



On-Premises/Hybrid Cloud

NetApp Solutions

NetApp
July 31, 2024

Table of Contents

- On-Premises/Hybrid Cloud 1
 - TR-4996: Oracle SI Deployment and Protection in VCF with vVols 1
 - TR-4992: Simplified, Automated Oracle Deployment on NetApp C-Series with NFS 60
 - TR-4983: Simplified, Automated Oracle Deployment on NetApp ASA with iSCSI 88
 - NVA-1155: Oracle 19c RAC databases on FlexPod Datacenter with Cisco UCS and NetApp AFF A800 over FC - Design and deployment guide 105
 - TR-4250: SAP with Oracle on UNIX and NFS with NetApp Clustered Data ONTAP and SnapManager for SAP 3.4 105
 - Deploying Oracle Database 105
 - Solution Overview 126
 - TR-4794: Oracle databases on NetApp EF-Series 149

On-Premises/Hybrid Cloud

TR-4996: Oracle SI Deployment and Protection in VCF with vVols

Allen Cao, Niyaz Mohamed, NetApp

The solution provides an overview and details for Oracle deployment and protection in VMware Cloud Foundation (VCF) with vSphere Virtual Volumes (vVols) as primary database storage and Oracle database in a single instance (SI) configuration..

Purpose

VMware vSphere Virtual Volumes (vVols) is a SAN/NAS management and integration framework that exposes virtual disks as native storage objects and enables array-based operations at the virtual disk level. In other words, vVols make SAN/NAS devices VM-aware and unlocks the ability to leverage array-based data services with a VM-centric approach at the granularity of a single virtual disk. vVols allows customers to leverage the unique capabilities of their current storage investments and transition without disruption to a simpler and more efficient operational model optimized for virtual environments that work across all storage types.

This documentation demonstrates the deployment and protection of an Oracle single instance database in a VMware Cloud Foundation environment with vVols as primary database storage in a NetApp ONTAP storage cluster. Oracle database is configured as if it is deployed in local file systems on a local storage system. This technical report focuses on steps in creating vVols in VCF for Oracle deployment. We also demonstrate how to use the NetApp SnapCenter UI tool to backup, restore, and clone an Oracle database for dev/test or other use cases for storage-efficient database operation in VCF.

This solution addresses the following use cases:

- Oracle SI database deployment in VCF with vVols datastore on NetApp ONTAP AFF as primary database storage
- Oracle database backup and restore in VCF with vVols datastore using NetApp SnapCenter UI tool
- Oracle database clone for dev/test or other use cases in VCF with vVols datastore using NetApp SnapCenter UI tool

Audience

This solution is intended for the following people:

- A DBA who would like to deploy Oracle in VCF with vVols datastore on NetApp ONTAP AFF as primary database storage
- A database solution architect who would like to test Oracle workloads in VCF with vVols datastore on NetApp ONTAP AFF storage
- A storage administrator who would like to deploy and manage an Oracle database deployed to VCF with vVols datastore on NetApp ONTAP AFF storage
- An application owner who would like to stand up an Oracle database in VCF with vVol datastore

Solution test and validation environment

The testing and validation of this solution was performed in a lab environment with VCF with vVols datastore on NetApp ONTAP AFF storage that might not match the final deployment environment. For more information, see the section [Key factors for deployment consideration](#).

Architecture

Oracle Single Instance Deployment and Protection in VCF with vVols

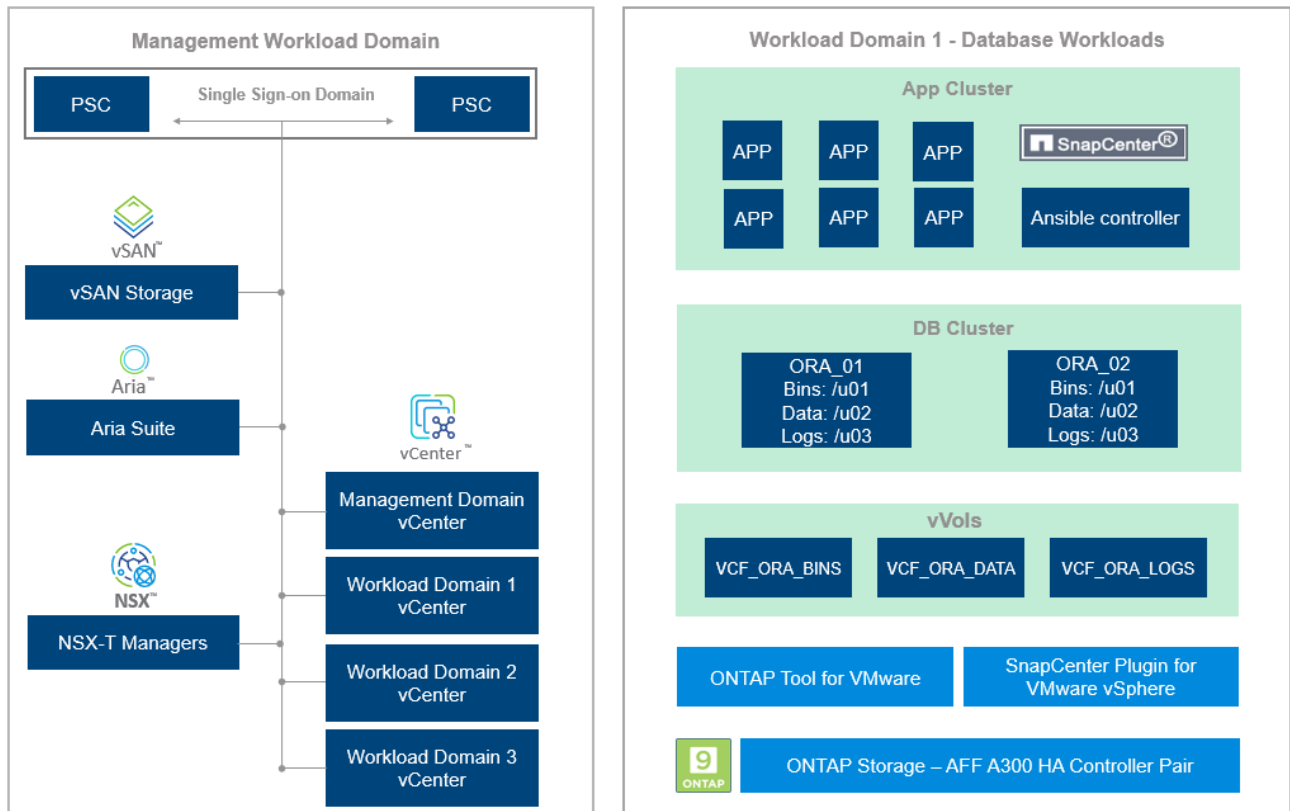

NetApp

Hardware and software components

Hardware

NetApp ONTAP AFF A300	Version 9.14.1P4	DS224 shelf with 24 NVMe disks, total capacity 35.2 TiB
VMware VSphere cluster	Version 8.02	12 CPU(s) x Intel® Xeon® Gold 5218 CPU @ 2.30GHz, 8 nodes (4 management and 4 workload domains)

Software

RedHat Linux	RHEL-8.6, 4.18.0-372.9.1.el8.x86_64 kernel	Hosting Oracle DB servers, deployed RedHat subscription for testing
Windows Server	2022 Standard, 10.0.20348 Build 20348	Hosting SnapCenter server

Centos Linux	CentOS Linux release 8.5.2111	Hosting Ansible controller
Oracle Database	Version 19.18	Applied RU patch p34765931_190000_Linux-x86-64.zip
Oracle OPatch	Version 12.2.0.1.36	Latest patch p6880880_190000_Linux-x86-64.zip
SnapCenter Server	Version 6.0	Workgroup deployment
SnapCenter Plug-in for VMware vSphere	Version 6.0	Deployed as an ova VM to vSphere cluster
ONTAP tool for VMware vSphere	Version 9.13	Deployed as an ova VM to vSphere cluster
Open JDK	Version java-11-openjdk-11.0.23.0.9-3.el8.x86_64	SnapCenter plugin requirement on DB VMs

Oracle database configuration in VCF

Server	Database	DB Storage
ora_01	NTAP1(NTAP1_pdb1,NTAP1_pdb2 ,NTAP1_pdb3)	vVols datastores on NetApp ONTAP AFF A300
ora_02	NTAP2(NTAP2_pdb1,NTAP2_pdb2 ,NTAP2_pdb3), NTAP1CLN	vVols datastores on NetApp ONTAP AFF A300

Key factors for deployment consideration

- **Protocol for vVols to ONTAP cluster connectivity.** NFS or iSCSI are good choices. The performance levels are equivalent. In this solution demonstration, we used NFS as a storage protocol for vVols connectivity to the underlined ONTAP storage cluster. If VCF infrastructure supports, FC/FCoE, NVMe/FC protocols are also supported for vVols datastores on NetApp ONTAP.
- **Oracle storage layout on vVols datastores.** In our tests and validations, we deployed three vVols datastores for Oracle binary, Oracle data, and Oracle log files. It's good practice to separate different types of Oracle files into their datastore so that database backup, recovery, or clone can be easily managed and executed. Create dedicate vVols for large databases and share vVols for smaller databases or databases with similar QoS profile.
- **Credential for ONTAP storage authentication.** Only use ONTAP cluster-level credentials for the ONTAP storage cluster authentication, including SnapCenter connectivity to the ONTAP storage cluster or ONTAP tool connectivity to the ONTAP storage cluster.
- **Provision storage from vVols datastore to database VM.** Add only one disk at a time to the database VM from the vVols datastore. Adding Multiple disks from vVols datastores at the same time is not supported at this time.
- **Database protection.** NetApp provides a SnapCenter software suite for database backup, restore, and cloning with a user-friendly UI interface. NetApp recommends implementing such a management tool to achieve fast (under a minute) SnapShot backup, quick (minutes) database restore, and database clone.

Solution deployment

The following sections provide step-by-step procedures for Oracle 19c deployment in VCF with vVols datastores on NetApp ONTAP storage in an Oracle single instance configuration.

Prerequisites for deployment

Deployment requires the following prerequisites.

1. A VMware VCF has been setup. For information or instruction on how to create a VCF, please refer to VMware documentation [VMware Cloud Foundation Documentation](#).
2. Provision three Linux VMs, two VMs for Oracle database and one VM for Ansible controller within VCF workload domain. Provision one Windows server VM for running NetApp SnapCenter server. For information on setting up Ansible controller for automated Oracle database deployment, referring to following resources [Getting Started with NetApp solution automation](#).
3. SnapCenter plugin version 6.0 for VMware vSphere has been deployed in VCF. Refer to following resources for the plugin deployment: [SnapCenter Plug-in for VMware vSphere documentation](#).
4. ONTAP tool for VMware vSphere has been deployed in VCF. Refer to following resources for the ONTAP tool for VMware vSphere deployment: [ONTAP tools for VMware vSphere documentation](#)



Ensure that you have allocated at least 50G in Oracle VM root volume in order to have sufficient space to stage Oracle installation files.

Create storage capability profile

First, create a custom storage capability profile for the underlined ONTAP storage that is hosting the vVols datastore.

1. From vSphere client shortcuts, open NetApp ONTAP tool. Ensure that ONTAP storage cluster has been added to Storage Systems as part of ONTAP tool deployment.

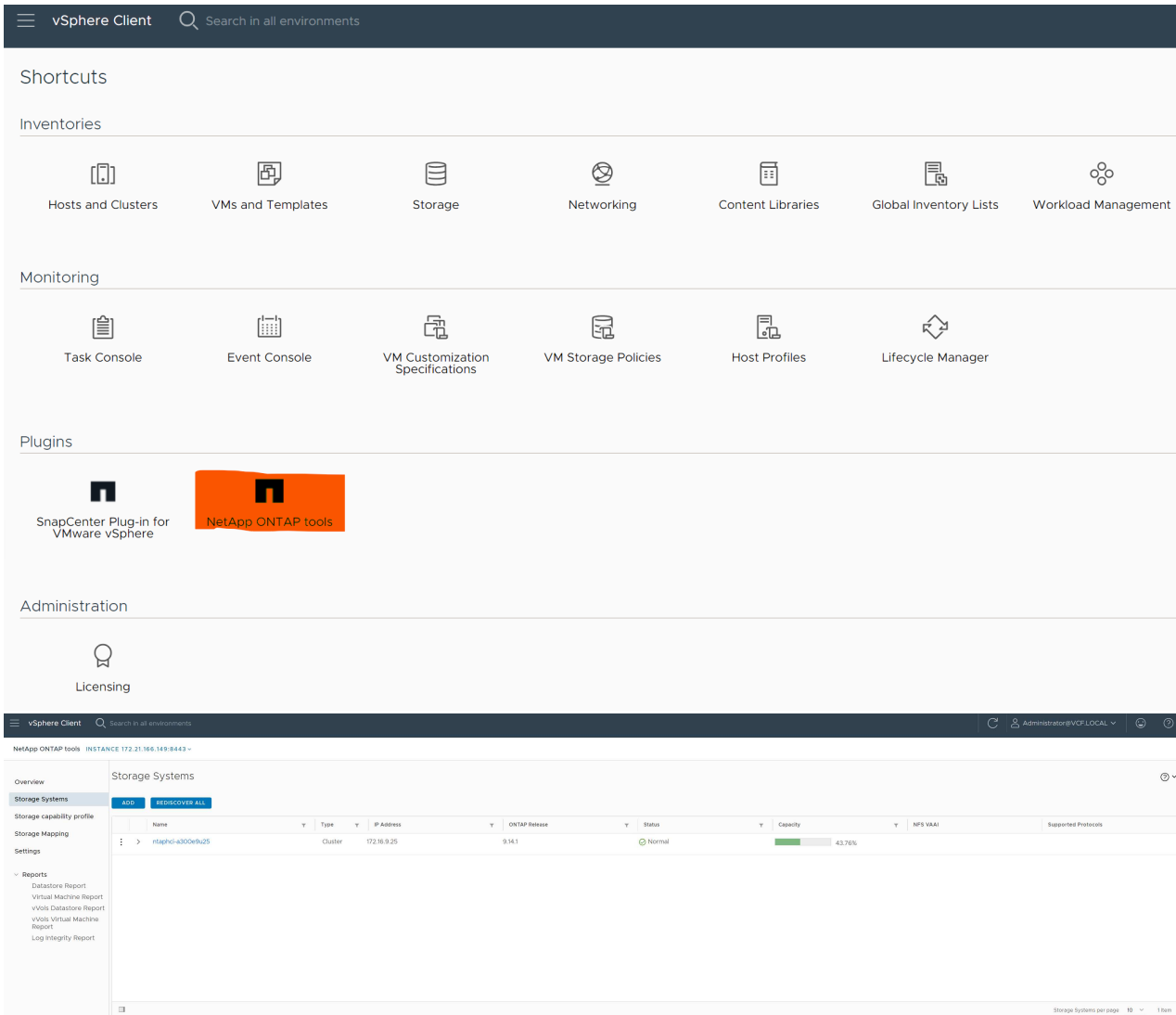

2. Click on Storage capability profile to add a custom profile for Oracle. Name the profile and add a brief description.

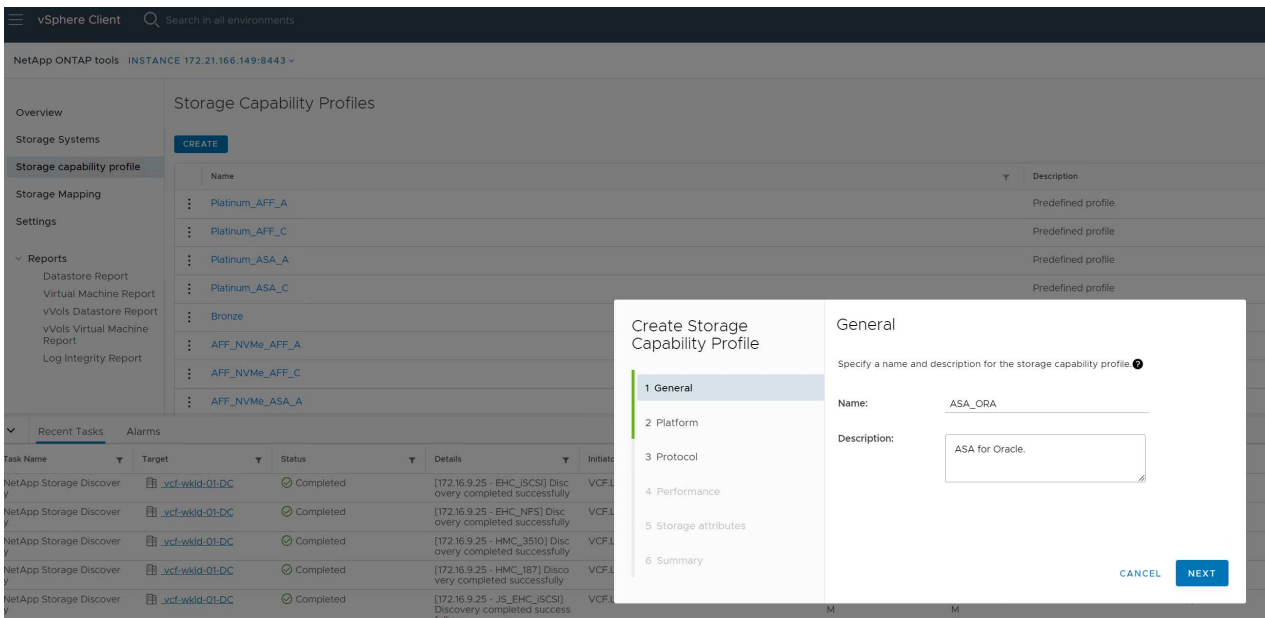

3. Choose storage controller category: performance, capacity, or hybrid.

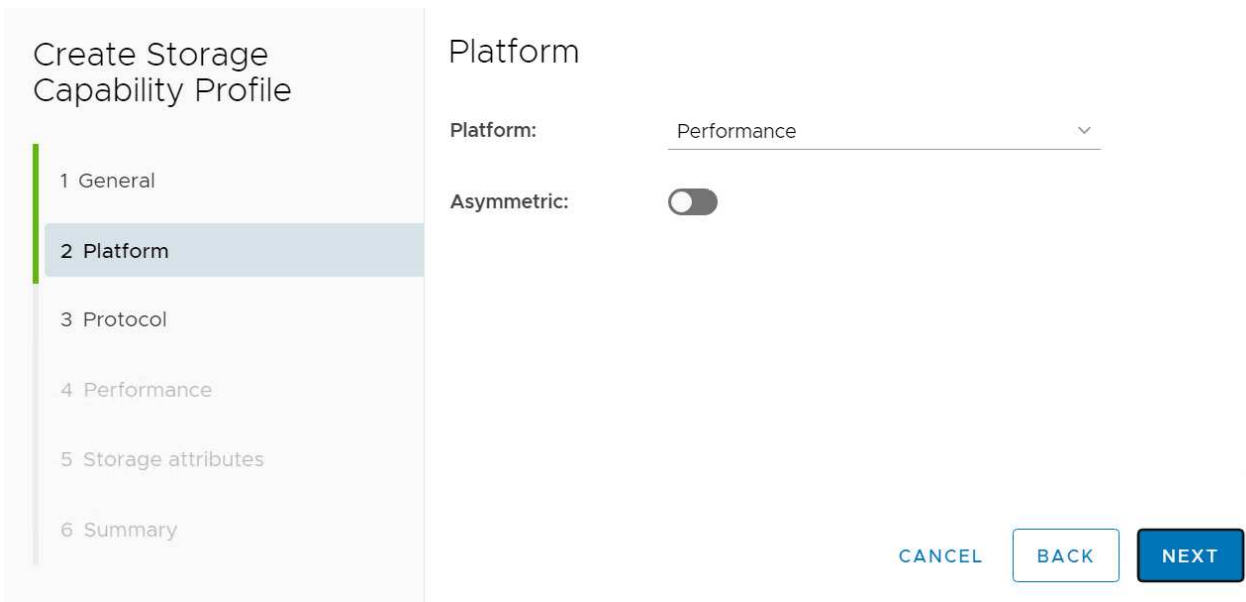

4. Select the protocol.

Create Storage Capability Profile

- 1 General
- 2 Platform
- 3 Protocol**
- 4 Performance
- 5 Storage attributes
- 6 Summary

Protocol

Protocol:

CANCEL

BACK

NEXT

5. Define a QoS policy if desired.

Create Storage Capability Profile

- 1 General
- 2 Platform
- 3 Protocol
- 4 Performance**
- 5 Storage attributes
- 6 Summary

Performance

- None ⓘ
- QoS policy group ⓘ

Min IOPS:

Max IOPS:

Unlimited

CANCEL

BACK

NEXT

6. Additional storage attributes for the profile. Be sure that the encryption is enabled on the NetApp controller if you want to have the encryption capability or it may cause issues when applying the profile.

Create Storage Capability Profile

- 1 General
- 2 Platform
- 3 Protocol
- 4 Performance
- 5 Storage attributes**
- 6 Summary

Storage attributes

Deduplication:	Yes	▼
Compression:	Yes	▼
Space reserve:	Thin	▼
Encryption:	Yes	▼
Tiering policy (FabricPool):	None	▼

CANCEL

BACK

NEXT

7. Review the summary and finish the storage capability profile creation.

Create Storage Capability Profile

- 1 General
- 2 Platform
- 3 Protocol
- 4 Performance
- 5 Storage attributes
- 6 Summary**

Summary

Name:	ASA_ORA
Description:	ASA for Oracle.
Platform:	Performance
Asymmetric:	No
Protocol:	Any
Performance:	None
Space reserve:	Thin
Deduplication:	Yes
Compression:	Yes
Encryption:	Yes
Tiering policy (FabricPool):	None

CANCEL

BACK

FINISH

Create and configure vVols datastore

With the prerequisites completed, login to the VCF as an admin user via vSphere client, navigating to workload domain. Do not use built-in VMware storage option to create vVols. Instead, use NetApp ONTAP tool to create vVols. Following demonstrates the procedures to create and configure vVols.

1. The vVols creation workflow can be triggered either from ONTAP tool interface or from VCF workload domain cluster.

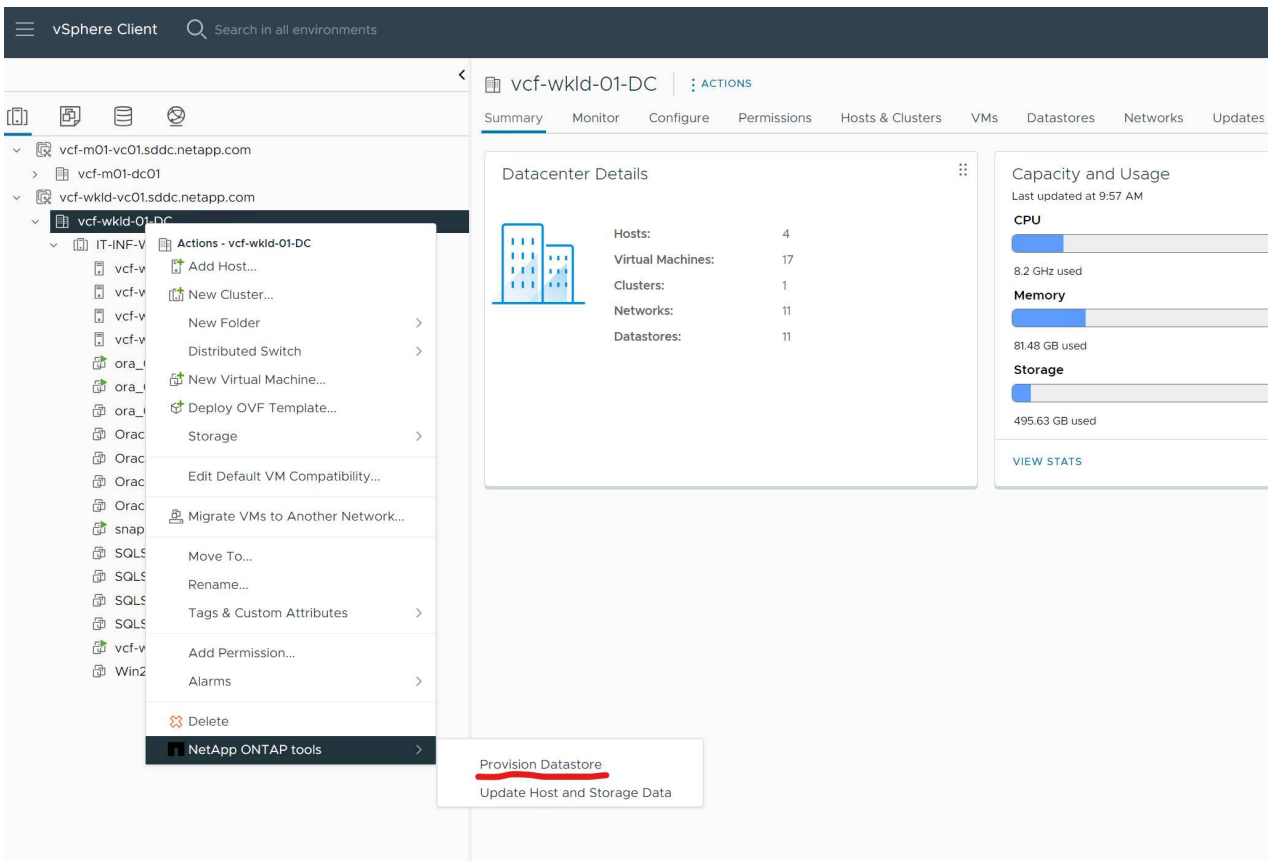
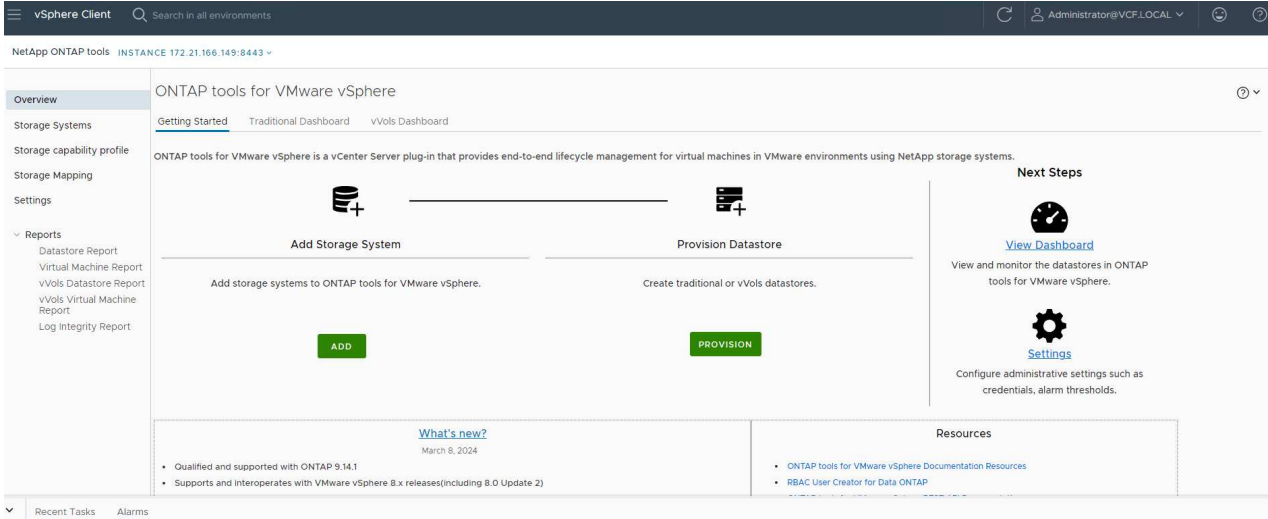

2. Filling in general information for datastore including provisioning destination, type, name, and protocol.

New Datastore

1 General

2 Storage system

3 Storage attributes

4 Summary

General

Specify the details of the datastore to provision 

Provisioning destination: [BROWSE](#)

Type: NFS VMFS vVols

Name:

Description:

Protocol: NFS iSCSI FC / FCoE NVMe/FC

[CANCEL](#)

[NEXT](#)

3. Select the custom storage capability profile created from previous step, the Storage system, and Storage VM, where vVols are to be created.

New Datastore

1 General

2 Storage system

3 Storage attributes

4 Summary

Storage system

Specify the storage capability profiles and the storage system you want to use.

Storage capability profiles:

Custom profiles

Storage system:

Storage VM:

[CANCEL](#)

[BACK](#)

[NEXT](#)

4. Choose **Create new volumes**, fill in the volume name and size and click on **ADD** then **NEXT** to move to the summary page.

New Datastore

- 1 General
- 2 Storage system
- 3 Storage attributes
- 4 Summary

Storage attributes

Specify the storage details for provisioning the datastore.

Volumes: Create new volumes Select volumes

Create new volumes

Name	Size	Storage Capability Profile	Aggregate
 FlexVol volumes are not added.			

Name	Size(GB)	Storage capability profile	Aggregates	Space reserve
vcf_ora_bins	150	ASA_ORA	EHCAGgr02 - (17899.73 G)	Thin

ADD

CANCEL

BACK

NEXT



You could add more than one volume to a vVols datastore or span a vVols datastore volumes across ONTAP controller nodes for performance.

5. Click **Finish** to create vVols datastore for Oracle binary.

New Datastore

- 1 General
- 2 Storage system
- 3 Storage attributes
- 4 Summary

Summary

General

vCenter server:	vcf-wkld-vc01.sddc.netapp.com
Provisioning destination:	vcf-wkld-01-DC
Datastore name:	VCF_ORA_BINS
Datastore type:	vVols
Protocol:	NFS
Storage capability profile:	ASA_ORA

Storage system details

Storage system:	ntaphci-a300e9u25
SVM:	VCF_NFS

Storage attributes

New FlexVol Name	New FlexVol Size	Aggregate	Storage Capability Profile
------------------	------------------	-----------	----------------------------

CANCEL

BACK

FINISH

6. Repeat the same procedures to create vVols datastore for Oracle data and log.

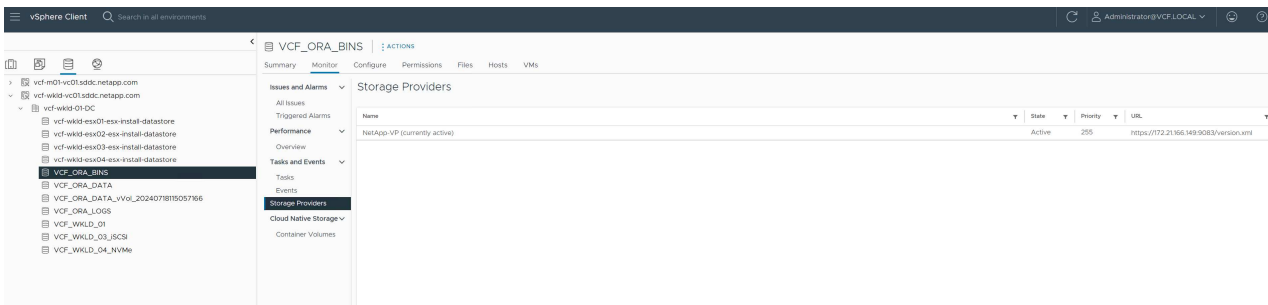



Notice that when an Oracle database is cloned, an additional vVols for Data is added to the vVols list.

Create VM storage policy based on storage capability profile

Before provisioning storage from vVols datastore to database VM, add a VM storage policy based on storage capability profile created from previous step. Following are the procedures.

1. From vSphere client menus, open Policies and Profiles and highlight VM Storage Policies. Click Create to open VM Storage Policies workflow.

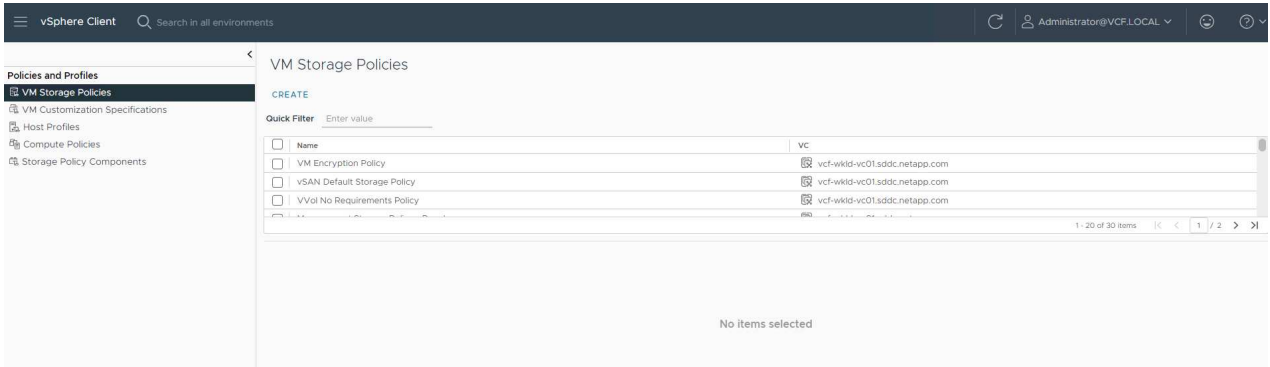

2. Name the VM storage policy.

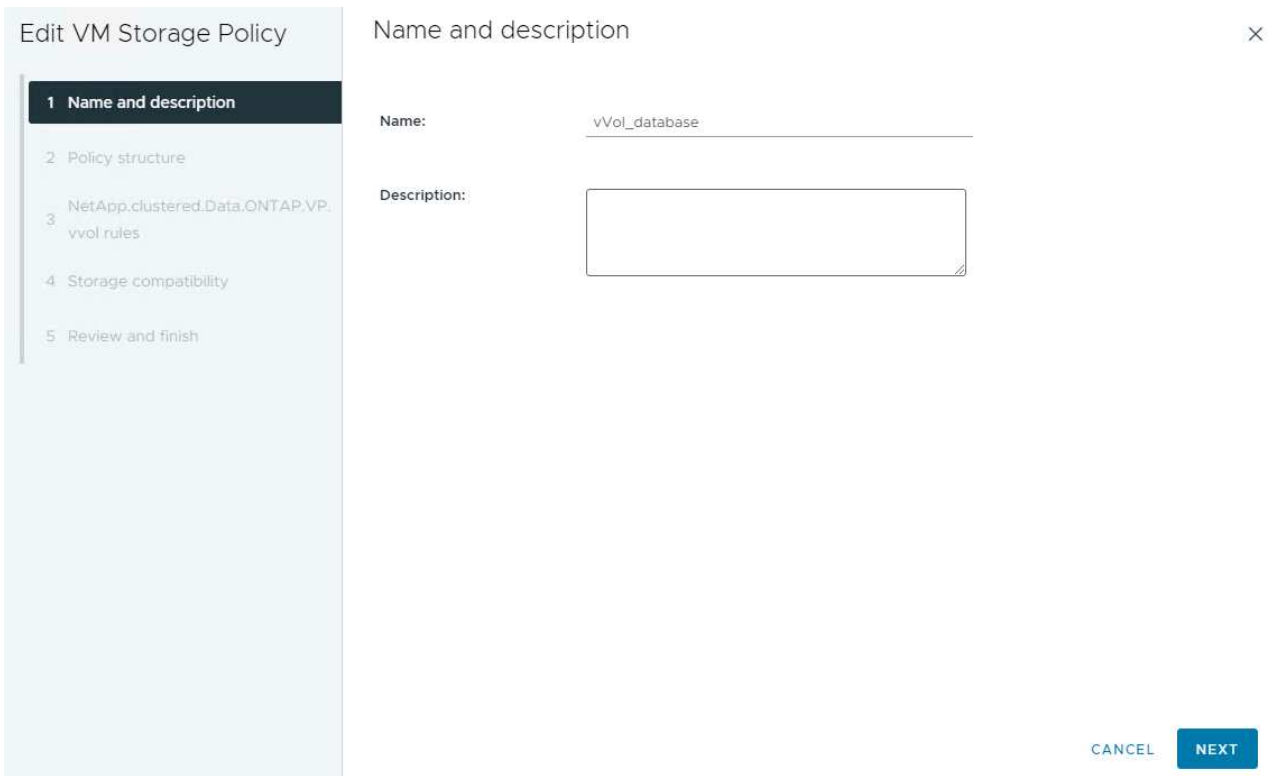

3. In Datastore specific rules, check Enable rules for "NetAPP.clustered.Data.ONTAP.VP.vvol" storage

Edit VM Storage Policy

1 Name and description

2 Policy structure

3 NetApp.clustered.Data.ONTAP.VP.vvol rules

4 Storage compatibility

5 Review and finish

Policy structure

×

Host based services

Create rules for data services provided by hosts. Available data services could include encryption, I/O control, caching, etc. Host based services will be applied in addition to any datastore specific rules.

Enable host based rules

Datastore specific rules

Create rules for a specific storage type to configure data services provided by the datastores. The rules will be applied when VMs are placed on the specific storage type.

Enable rules for "vSAN" storage

Enable rules for "vSANDirect" storage

Enable rules for "VMFS" storage

Enable rules for "NetApp.clustered.Data.ONTAP.VP.vvol" storage

Enable tag based placement rules

Storage topology

Create rules for storage consumption domain topology. The storage topology will be applied to all datastore specific rules.

Enable consumption domain

CANCEL

BACK

NEXT

4. For NetApp.clustered.Data.ONTAP.VP.vvol rules Placement, select the custom storage capacity profile created from the previous step.

Create VM Storage Policy

1 Name and description

2 Policy structure

3 **NetApp.clustered.Data.ONTAP.VP.vvol rules**

4 Storage compatibility

5 Review and finish

NetApp.clustered.Data.ONTAP.VP.vvol rules



Placement Replication Tags

ProfileName ⓘ

ASA_ORA

CANCEL

BACK

NEXT

5. For NetApp.clustered.Data.ONTAP.VP.vvol rules Replication, choose Disabled if vVols are not replicated.

Create VM Storage Policy

1 Name and description

2 Policy structure

3 **NetApp.clustered.Data.ONTAP.VP.vvol rules**

4 Storage compatibility

5 Review and finish

NetApp.clustered.Data.ONTAP.VP.vvol rules

×

Placement Replication Tags

Disabled

Custom

CANCEL

BACK

NEXT

6. Storage compatibility page displays the compatible vVols datastores in VCF environment.

Create VM Storage Policy

- 1 Name and description
- 2 Policy structure
- 3 NetApp.clustered.Data.ONTAP.VP.vvol rules
- 4 Storage compatibility**
- 5 Review and finish

Storage compatibility



COMPATIBLE INCOMPATIBLE

Expand datastore clusters

Compatible storage 650 GB (650 GB free)

Quick Filter

Name	Datacenter	Type	Free Space	Capacity	Warnings
VCF_ORA_BINS	vcf-wkld-01-DC	vVol	150.00 GB	150.00 GB	
VCF_ORA_DATA	vcf-wkld-01-DC	vVol	250.00 GB	250.00 GB	
VCF_ORA_LOGS	vcf-wkld-01-DC	vVol	250.00 GB	250.00 GB	

Manage Columns

3 Items

CANCEL

BACK

NEXT

7. Review and finish to create the VM Storage Policy.

Create VM Storage Policy

- 1 Name and description
- 2 Policy structure
- 3 NetApp.clustered.Data.ONTAP.VP.vvol rules
- 4 Storage compatibility
- 5 Review and finish

Review and finish

General

Name: vVol_database

Description: vCenter Server: vcf-wkld-vc01.sddc.netapp.com

NetApp.clustered.Data.ONTAP.VP.vvol rules

Placement: ProfileName: ASA_ORA

×

CANCEL
BACK
FINISH

8. Validate the VM Storage Policy just created.

The screenshot shows the vSphere Client interface. On the left, the 'Policies and Profiles' sidebar is visible, with 'VM Storage Policies' selected. The main area displays a list of VM Storage Policies. The policy 'vVol_database' is highlighted. Below the list, the details for the selected policy are shown:

Rules	VM Compliance	VM Template	Storage Compatibility
General			
Name	vVol_database		
Description	vCenter Server: vcf-wkld-vc01.sddc.netapp.com		
Rule-set 1: NetApp.clustered.Data.ONTAP.VP.vvol			
Placement	ProfileName: ASA_ORA		
Storage Type	NetApp.clustered.Data.ONTAP.VP.vvol		
ProfileName	ASA_ORA		

Allocate disks to DB VM from vVols datastores and configure DB storage

From vSphere client, add three disks from the vVols datastores to database VM by editing VM settings. Then, login to VM to format and mount the disks to mount points /u01, /u02, and /u03. The following demonstrates the exact steps and tasks.

1. Add a disk to VM for Oracle binary storage.

Edit Settings | ora_01

Virtual Hardware VM Options Advanced Parameters

ADD NEW DEVICE ▾

> CPU	4 ▾ ⓘ	
> Memory	16	GB ▾
> Hard disk 1	50	GB ▾
▾ New Hard disk *	50	GB ▾
Maximum Size	142.5 GB	
VM storage policy	vVol_database ▾	
Location	VCF_ORA_BINS ▾	
Disk Provisioning	Thin Provision ▾	
Sharing	No sharing ▾	
Disk Mode	Dependent ▾	

CANCEL

OK

2. Add a disk to VM for Oracle data storage.

Edit Settings | ora_01



Virtual Hardware VM Options Advanced Parameters

ADD NEW DEVICE ▾

> CPU	4 ▾	
> Memory	16	GB ▾
> Hard disk 1	50	GB ▾
> New Hard disk *	50	GB ▾
▼ New Hard disk 2 *	100	GB ▾
Maximum Size	475 GB	
VM storage policy	vVol_database ▾	
Location	VCF_ORA_DATA ▾	
Disk Provisioning	Thin Provision ▾	
Sharing	No sharing ▾	

CANCEL

OK

3. Add a disk to VM for Oracle log storage.

ADD NEW DEVICE ▾

> CPU	4 ▾ ⓘ		
> Memory	16	▾ GB ▾	
> Hard disk 1	50	GB ▾	⋮
> New Hard disk *	50	GB ▾	⋮
> New Hard disk 2 *	100	GB ▾	⋮
▾ New Hard disk 3 *	100	GB ▾	⋮
Maximum Size	285 GB		
VM storage policy	vVol_database ▾		
Location	VCF_ORA_LOGS ▾		
Disk Provisioning	Thin Provision ▾		
Sharing	No sharing ▾		

CANCEL

OK

4. From VM Edit Settings, Advanced Parameters, add Attribute `disk.enableuuid` with Value `TRUE`. The VM needs to be down to add the advanced parameter. Setting this option enables SnapCenter to precisely identify the vVol in your environment.

Advanced Configuration Parameters

Modify or add configuration parameters as needed for experimental features or as instructed by technical support. Empty values will be removed (supported on ESXi 6.0 and later).

Attribute Value

Attribute	Value
sched.cpu.latencySensitivity	normal
tools.guest.desktop.autoLock	TRUE
svga.present	TRUE
pciBridge0.present	TRUE
pciBridge4.present	TRUE
pciBridge4.virtualDev	pcieRootPort
pciBridge4.functions	8
pciBridge5.present	TRUE
pciBridge5.virtualDev	pcieRootPort
pciBridge5.functions	8
pciBridge6.present	TRUE

5. Now, restart the VM. Login to VM as an admin user via ssh to review the newly added disk drives.

```
[admin@ora_01 ~]$ sudo fdisk -l
```

```
Disk /dev/sdb: 50 GiB, 53687091200 bytes, 104857600 sectors  
Units: sectors of 1 * 512 = 512 bytes  
Sector size (logical/physical): 512 bytes / 512 bytes  
I/O size (minimum/optimal): 512 bytes / 512 bytes
```

```
Disk /dev/sdc: 100 GiB, 107374182400 bytes, 209715200 sectors  
Units: sectors of 1 * 512 = 512 bytes  
Sector size (logical/physical): 512 bytes / 512 bytes  
I/O size (minimum/optimal): 512 bytes / 512 bytes
```

```
Disk /dev/sdd: 100 GiB, 107374182400 bytes, 209715200 sectors  
Units: sectors of 1 * 512 = 512 bytes  
Sector size (logical/physical): 512 bytes / 512 bytes  
I/O size (minimum/optimal): 512 bytes / 512 bytes
```

```
.  
. .  
.
```

6. Partition the drives as a primary and single partition by simply accepting the default choices.

```
sudo fdisk /dev/sdb
```

```
sudo fdisk /dev/sdc
```

```
sudo fdisk /dev/sdd
```

7. Format the partitioned disks as xfs file systems.

```
sudo mkfs.xfs /dev/sdb1
```

```
sudo mkfs.xfs /dev/sdc1
```

```
sudo mkfs.xfs /dev/sdd1
```

8. Mount the drives to mount point /u01, /u02, and /u03.

```
sudo mount -t xfs /dev/sdb1 /u01
```

```
sudo mount -t xfs /dev/sdc1 /u02
```

```
sudo mount -t xfs /dev/sdd1 /u03
```

```
[admin@ora_01 ~]$ df -h
```

Filesystem	Size	Used	Avail	Use%	Mounted on
devtmpfs	7.7G	0	7.7G	0%	/dev
tmpfs	7.8G	0	7.8G	0%	/dev/shm
tmpfs	7.8G	782M	7.0G	10%	/run
tmpfs	7.8G	0	7.8G	0%	/sys/fs/cgroup
/dev/mapper/rhel-root	44G	19G	26G	43%	/
/dev/sda1	1014M	258M	757M	26%	/boot
tmpfs	1.6G	12K	1.6G	1%	/run/user/42
tmpfs	1.6G	4.0K	1.6G	1%	/run/user/1000
/dev/sdb1	50G	390M	50G	1%	/u01
/dev/sdc1	100G	746M	100G	1%	/u02
/dev/sdd1	100G	746M	100G	1%	/u03

9. Add mount points to `/etc/fstab` so that disk drives will be mounted when VM reboots.

```
sudo vi /etc/fstab
```

```

[oracle@ora_01 ~]$ cat /etc/fstab

#
# /etc/fstab
# Created by anaconda on Wed Oct 18 19:43:31 2023
#
# Accessible filesystems, by reference, are maintained under
# '/dev/disk/'.
# See man pages fstab(5), findfs(8), mount(8) and/or blkid(8) for
# more info.
#
# After editing this file, run 'systemctl daemon-reload' to update
# systemd
# units generated from this file.
#
/dev/mapper/rhel-root / xfs defaults
0 0
UUID=aff942c4-b224-4b62-807d-6a5c22f7b623 /boot
xfs defaults 0 0
/dev/mapper/rhel-swap none swap defaults
0 0
/root/swapfile swap swap defaults 0 0
/dev/sdb1 /u01 xfs defaults
0 0
/dev/sdc1 /u02 xfs defaults
0 0
/dev/sdd1 /u03 xfs defaults
0 0

```

Oracle database deployment in VCF

It's recommended to leverage NetApp automation toolkit to deploy Oracle in VCF with vVols. For detailed reference on executing Oracle automated deployment on xfs file systems, refer to TR-4992: [Simplified, Automated Oracle Deployment on NetApp C-Series with NFS](#). Although the TR-4992 covers automated Oracle deployment on the NetApp C-Series with NFS, it's identical to Oracle deployment in VCF with vVols if bypassing NFS file systems mounting to database VM. We would simply skip that with specific tags. Following are step by step procedures.

1. Login to Ansible controller VM as admin user via ssh and clone a copy of automation toolkit for Oracle on NFS.

```
git clone https://bitbucket.ngage.netapp.com/scm/ns-  
bb/na_oracle_deploy_nfs.git
```

2. Stage the following Oracle installation files in /tmp/archive folder on database VM. The folder should allow all user access with 777 permission.

```
LINUX.X64_193000_db_home.zip  
p34765931_190000_Linux-x86-64.zip  
p6880880_190000_Linux-x86-64.zip
```

3. Configure deployment target file - hosts, global variables file - vars/vars.yml, and local DB VM variables file - host_vars/host_name.yml according to instructions in this section of TR-4992: [Parameter files configuration](#). Comment out nfs_lif variable from local DB VM variable file.
4. Set up ssh keyless authentication between Ansible controller and database VMs, which requires to generate a ssh key pair and copy the public key to database VMs admin user root directory .ssh folder authorized_keys file.

```
ssh-keygen
```

5. From Ansible controller, cloned automation toolkit home directory /home/admin/na_oracle_deploy_nf, execute prerequisites playbook.

```
ansible-playbook -i hosts 1-ansible_requirements.yml
```

6. Execute Linux configuration playbook.

```
ansible-playbook -i hosts 2-linux_config.yml -u admin -e  
@vars/vars.yml
```

7. Execute Oracle deployment playbook.

```
ansible-playbook -i hosts 4-oracle_config.yml -u admin -e
@vars/vars.yml --skip-tags "ora_mount_points,enable_dnfs_client"
```

8. Optionally, all above playbooks can be executed from a single playbook run as well.

```
ansible-playbook -i hosts 0-all_playbook.yml -u admin -e
@vars/vars.yml --skip-tags "ora_mount_points,enable_dnfs_client"
```

9. Login to EM express to to validate Oracle after successful playbook execution.

The image shows two screenshots of the Oracle Enterprise Manager Database Express interface. The top screenshot is the login page, displaying the Oracle logo and the text "ORACLE ENTERPRISE MANAGER DATABASE EXPRESS". It includes a login form with fields for Username (set to "system"), Password (masked with asterisks), and Container Name, along with a "Log In" button. The bottom screenshot shows the main dashboard for a database instance named "NTAP1 (19.18.0.0.0)". The dashboard includes a "Status" section with details like "Up Time: 6 days 3 hours, 17 minutes, 43 seconds" and "Type: Single Instance (NTAP1)". It also features a "Performance" section with a line graph for CPU usage, a "Resources" section with four bar charts for Host CPU, Active Sessions, Memory, and Data Storage, and an "SQL Monitor" section showing a table of the top 20 active SQL queries.

10. Optionally, execute destroy playbook to remove database from DB VM.

```
ansible-playbook -i hosts 5-destroy.yml -u admin -e @vars/vars.yml
```

Oracle backup, restore, and clone in VCF with SnapCenter

SnapCenter Setup

SnapCenter version 6 has many feature enhancements over version 5, including support for VMware vVols datastore. SnapCenter relies on a host-side plug-in on a database VM to perform application-aware data protection management activities. For detailed information on NetApp SnapCenter plug-in for Oracle, refer to this documentation [What can you do with the Plug-in for Oracle Database](#). The following provides high-level steps to set up SnapCenter version 6 for Oracle database backup, recovery, and clone in VCF.

1. Download the version 6 of SnapCenter software from NetApp support site: [NetApp Support Downloads](#).
2. Login to the SnapCenter hosting Windows VM as administrator. Install prerequisites for SnapCenter 6.0.

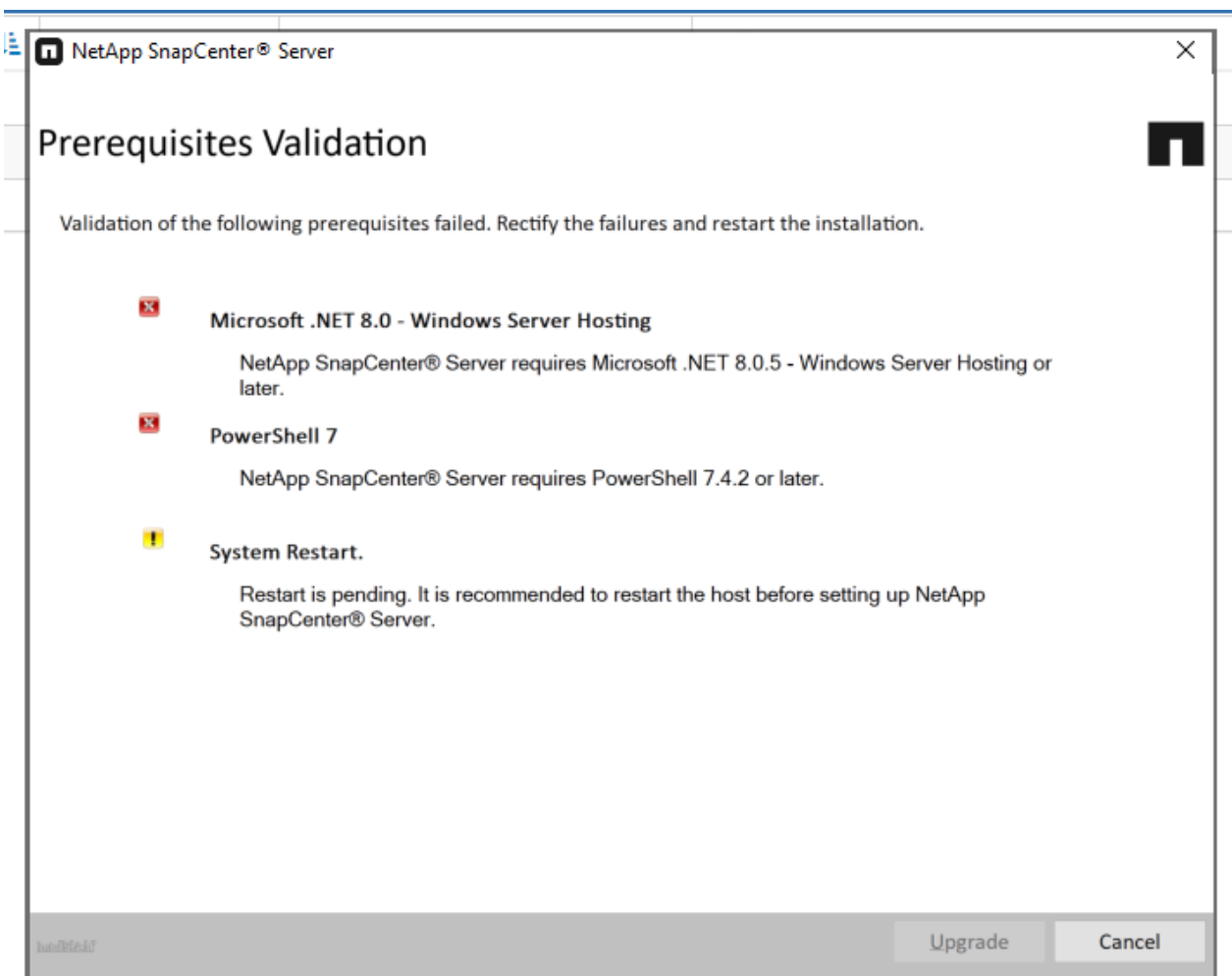

3. As administrator, install latest java JDK from [Get Java for desktop applications](#).



If Windows server is deployed in a domain environment, add a domain user to SnapCenter server local administrators group and run SnapCenter installation with the domain user.

4. Login to SnapCenter UI via HTTPS port 8846 as installation user to configure SnapCenter for Oracle.

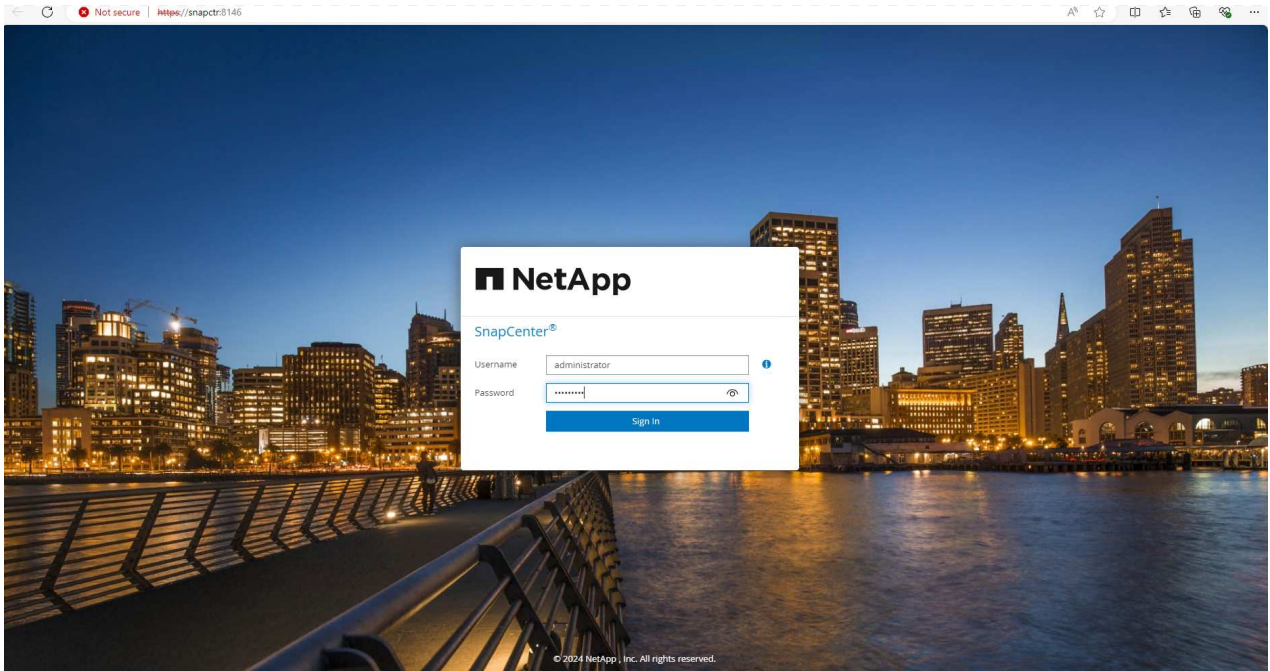

5. Review Get Started menu to get up to speed on SnapCenter if you are a new user.

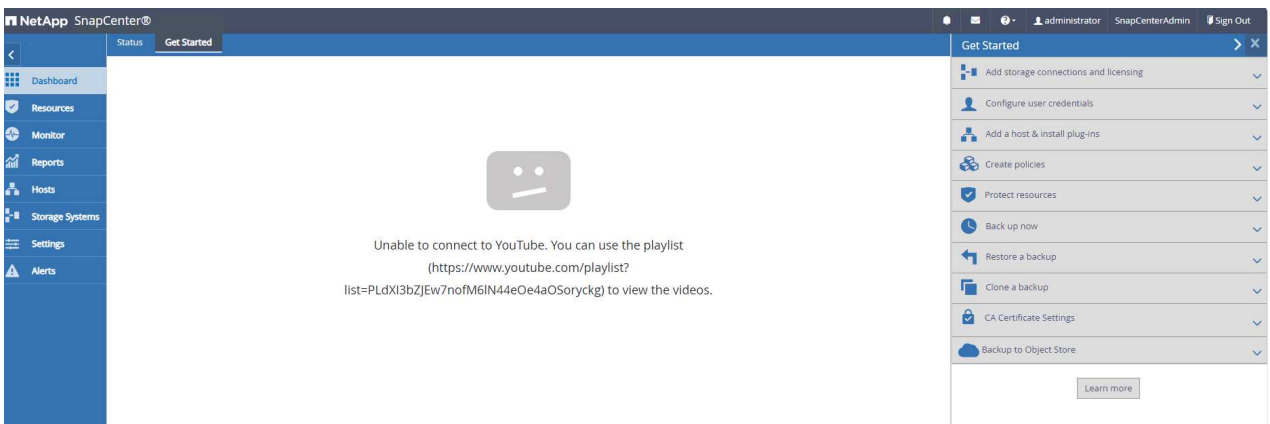

6. Update Hypervisor Settings in global settings.

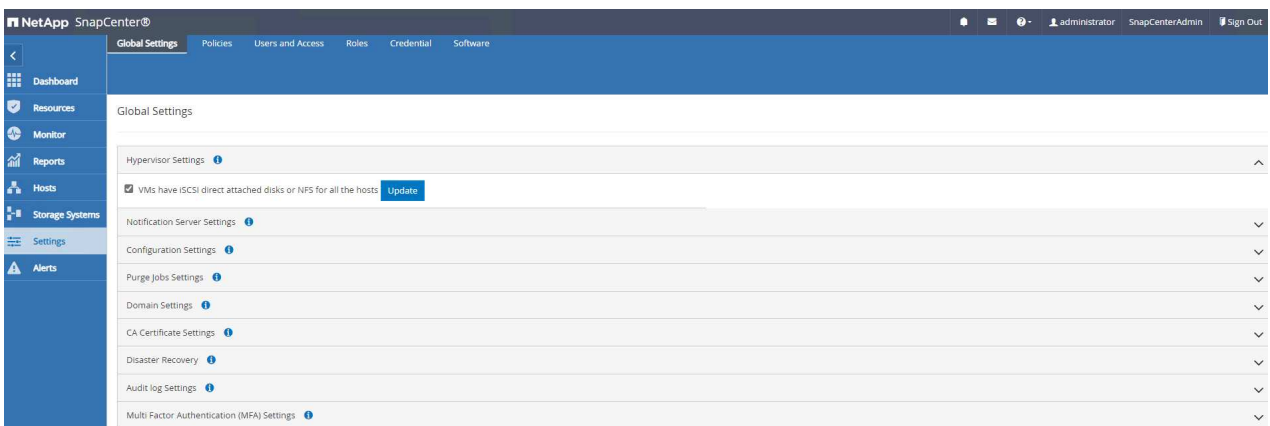

7. Add ONTAP storage cluster to Storage Systems with cluster management IP and authenticated via cluster admin user ID.

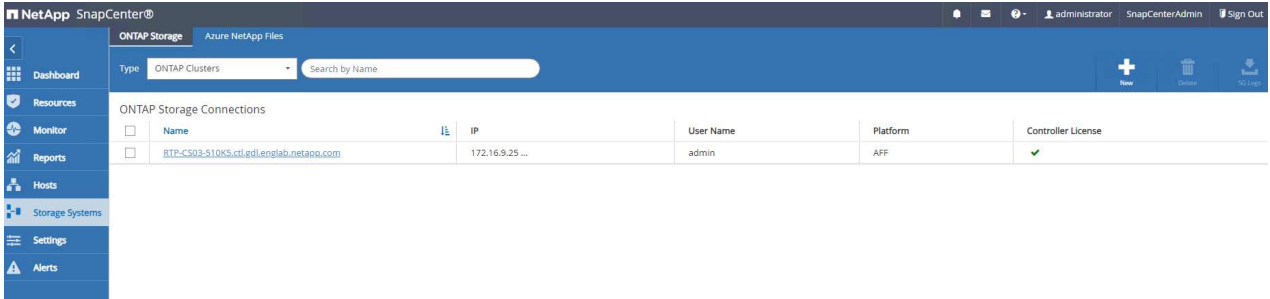
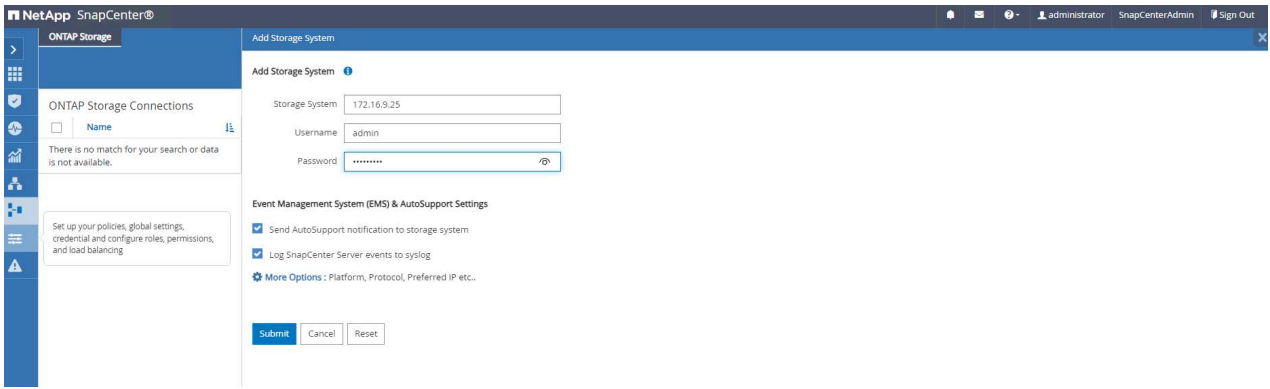

8. Add database VM and vSphere plugin VM `Credential` for SnapCenter access to DB VM and vSphere plugin VM. The credential should have sudo privilege on the Linux VMs. You may create different credentials for different management user IDs for the VMs.

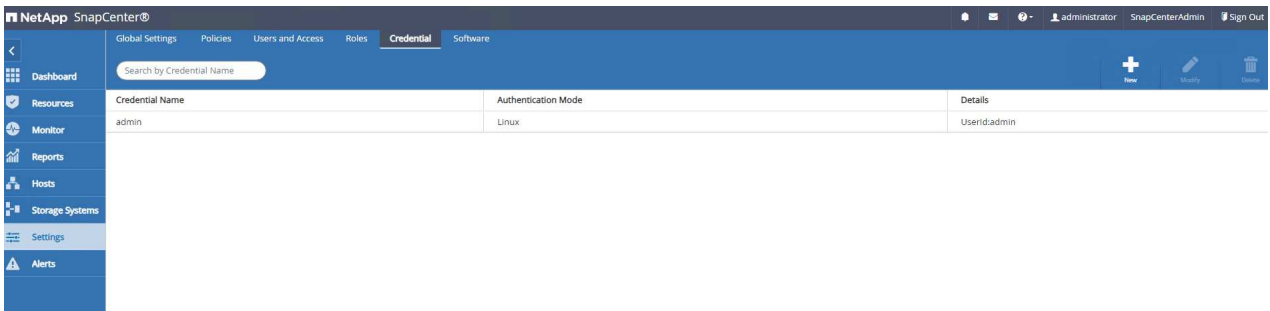

9. Add Oracle database VM in VCF to `Hosts` with DB VM credential created in previous step.

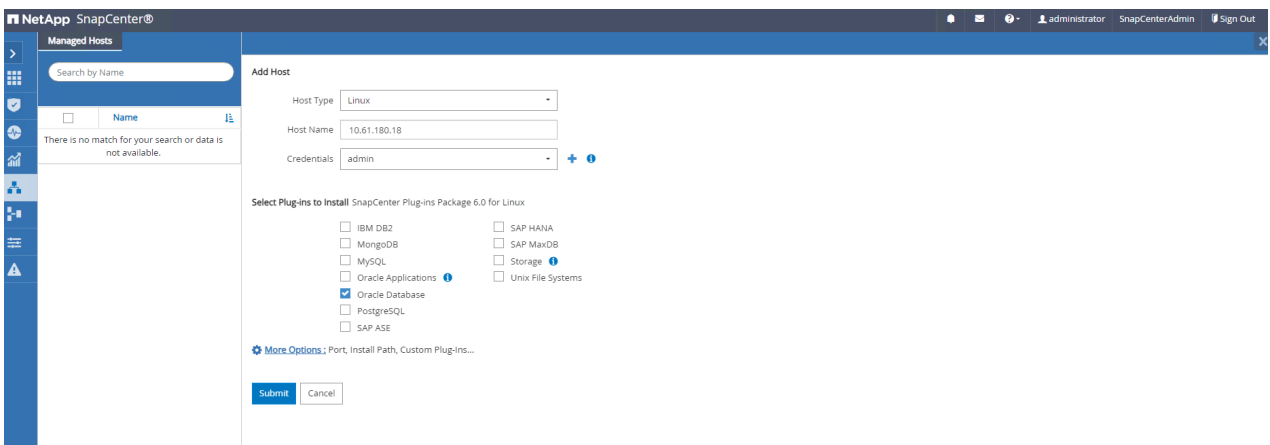

Confirm Fingerprint

Authenticity of the host cannot be determined i

Host name	Fingerprint	Valid
ora_01.sddc.netapp.com	ssh-ed25519 256 36:60:E6:D0:2B:F2:F8:90:97:A1:D3:83:40:7E:E3:7A	

Confirm and Submit
Close

NetApp SnapCenter®

Managed Hosts | Disks | Shares | Initiator Groups | iSCSI Session

Search by Name

<input type="checkbox"/>	Name	Type	System	Plug-in	Version	Overall Status
<input type="checkbox"/>	ora_01.sddc.netapp.com	Linux	Stand-alone	Oracle Database, UNIX	6.0	Running
<input type="checkbox"/>	ora_02.sddc.netapp.com	Linux	Stand-alone	Oracle Database, UNIX	6.0	Running

View all the alerts and its details.

- Similarly, add NetApp VMware plugin VM to `Hosts` with vSphere plugin VM credential created in previous step.

NetApp SnapCenter®

Managed Hosts

Search by Name

Add Host

Host Type: vSphere

Host Name: 172.21.166.14

Credentials: admin

Submit Cancel

NetApp SnapCenter®

Managed Hosts | Disks | Shares | Initiator Groups | iSCSI Session

Search by Name

<input type="checkbox"/>	Name	Type	System	Plug-in	Version	Overall Status
<input type="checkbox"/>	ora_01.sddc.netapp.com	Linux	Stand-alone	Oracle Database, UNIX	6.0	Running
<input type="checkbox"/>	ora_02.sddc.netapp.com	Linux	Stand-alone	Oracle Database, UNIX	6.0	Running
<input type="checkbox"/>	vcf001.sc5.sddc.netapp.com	vSphere	Stand-alone	VMware vSphere	6.0	Running

- Finally, after Oracle database is discovered on DB VM, back to `Settings-Policies` to create Oracle database backup policies. Ideally, create a separate archive log backup policy to allow more frequent backup interval to minimize data loss in the event of a failure.

NetApp SnapCenter®

Global Settings Policies Users and Access Roles Credential Software

Oracle Database

Search by Name

Name	Backup Type	Schedule Type	Replication	Verification
Oracle Archive Logs Backup	LOG, ONLINE	Hourly		
Oracle Online Full Backup	FULL, ONLINE	Hourly		



Ensure that the SnapCenter server name can be resolved to the IP address from the DB VM and vSphere plugin VM. Equally, the DB VM name and vSphere plugin VM name can be resolved to the IP address from the SnapCenter server.

Database backup

SnapCenter leverages ONTAP volume snapshot for much quicker database backup, restore, or clone compared with traditional RMAN based methodology. The snapshots are application-consistent as the database is put in Oracle backup mode before a snapshot.

1. From the Resources tab, any databases on the VM are auto-discovered after the VM is added to SnapCenter. Initially, the database status shows as Not protected.

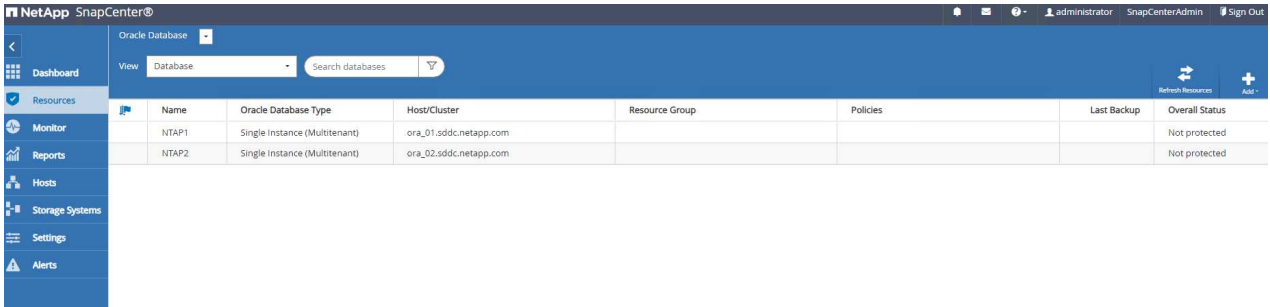

2. Click on database to start a workflow to enable protection for the database.

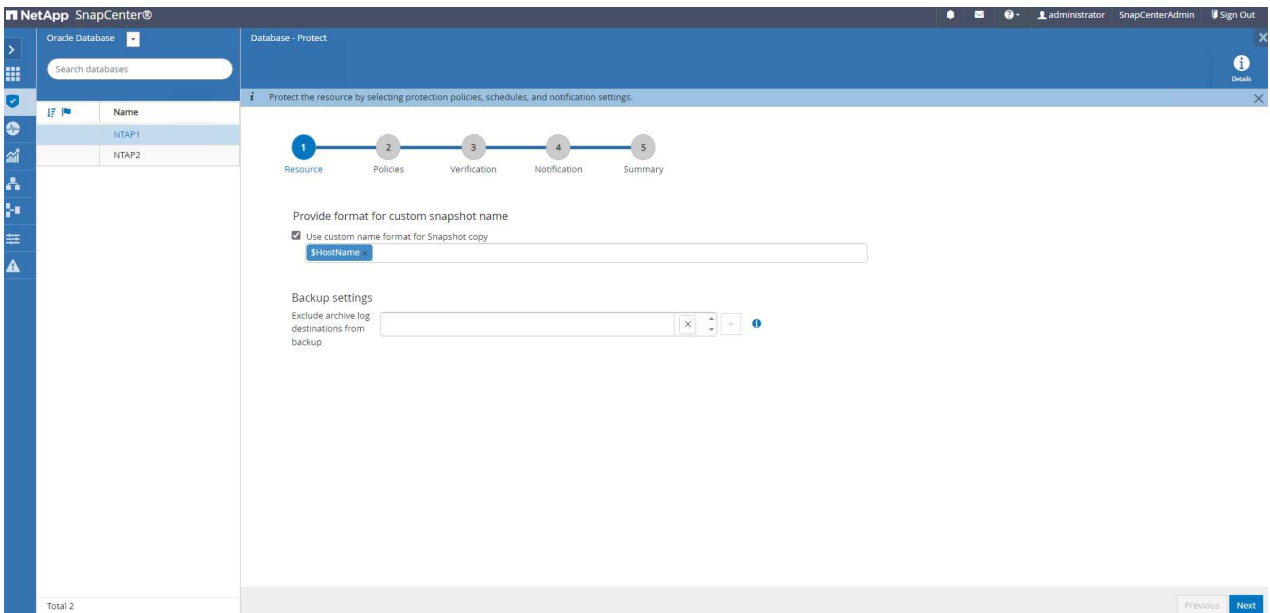

3. Apply backup policy, setup scheduling if needed.

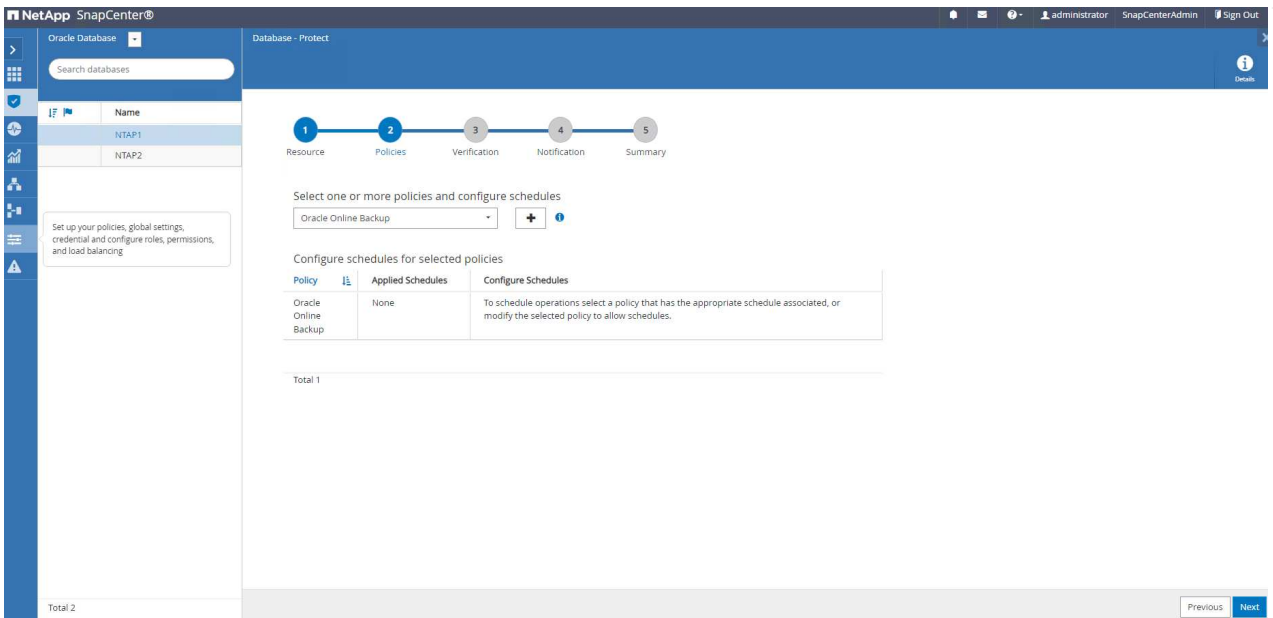

4. Setup backup job notification if required.

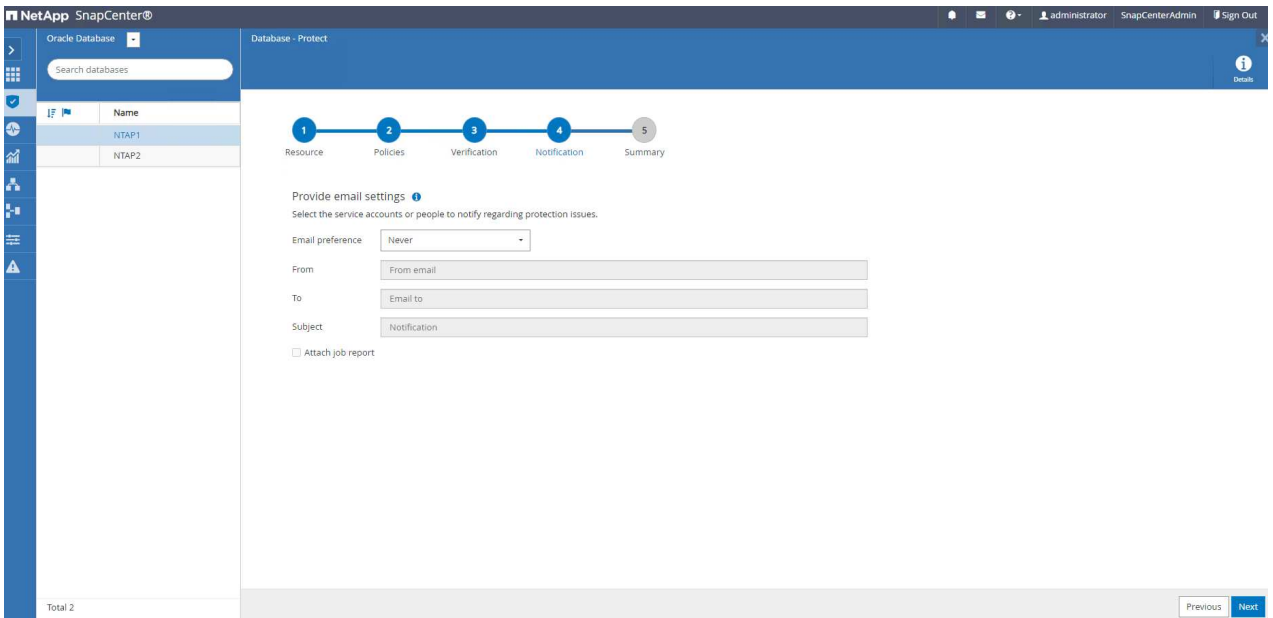

5. Review the summary and finish to enable database protection.

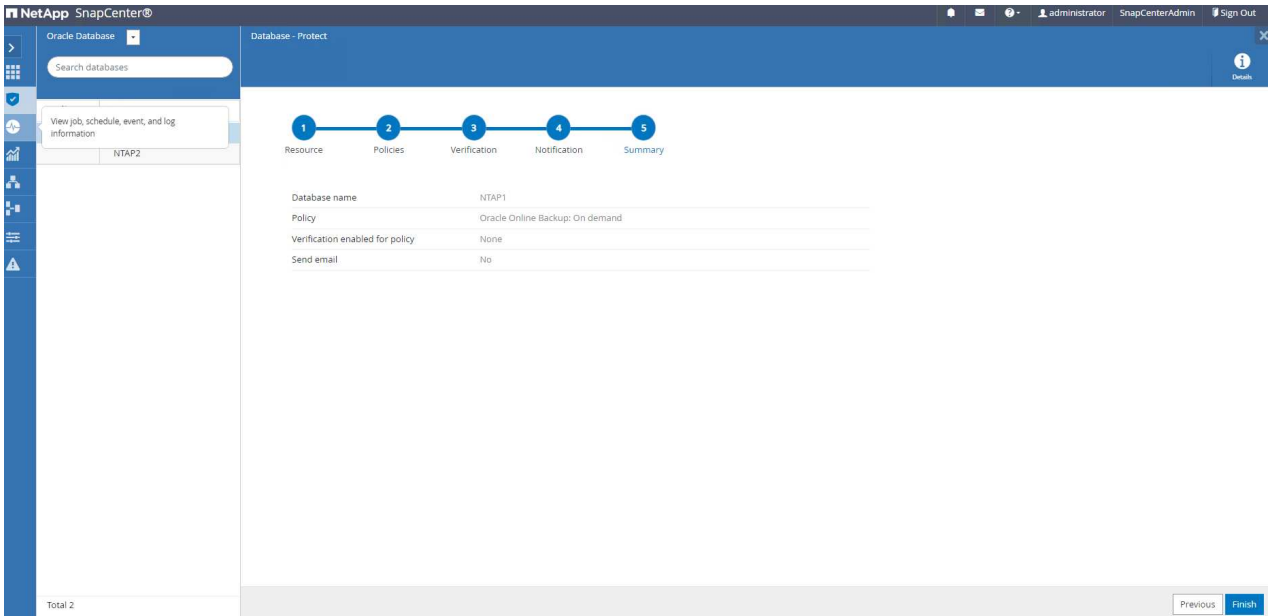

6. On-demand backup job can be triggered by click on **Back up Now**.

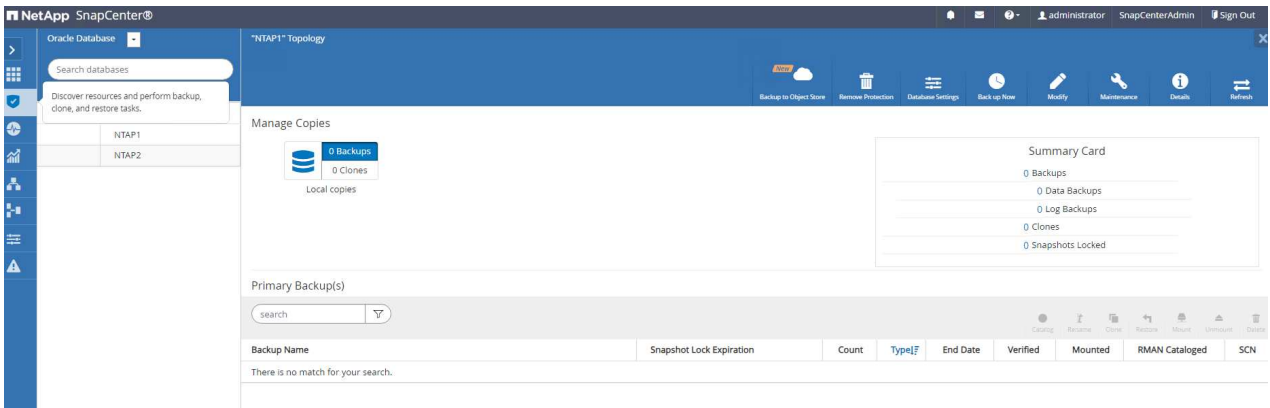

Backup



Create a backup for the selected resource

Resource Name

NTAP1

Policy

Oracle Online Backup



Verify after backup

Cancel

Backup

7. The backup job can be monitored at the `Monitor` tab by clicking on the running job.

Job Details



Backup of Resource Group 'ora_01_sddc_netapp_com_NTAP1' with policy 'Oracle Online Backup'

✓ ▾ Backup of Resource Group 'ora_01_sddc_netapp_com_NTAP1' with policy 'Oracle Online Backup'

✓ ▾ ora_01.sddc.netapp.com

- ✓ ▶ Prescripts
- ✓ ▶ Preparing for Oracle Database Backup
- ✓ ▶ Preparing for File-System Backup
- ✓ ▶ Backup datafiles and control files
- ✓ ▶ Backup archive logs
- ✓ ▶ Finalizing Oracle Database Backup
- ✓ ▶ Finalizing File-System Backup
- ✓ ▶ Postscripts
- ✓ ▶ Data Collection
- ✓ ▶ Send EMS Messages

📌 Task Name: ora_01.sddc.netapp.com Start Time: 07/16/2024 5:39:33 PM End Time: 07/16/2024 5:40:23 PM

View Logs

Cancel Job

Close

8. Click on database to review the backup sets completed for each database.

Manage Copies

4 Backups
1 Clone
Local copies

Summary Card

- 4 Backups
- 2 Data Backups
- 2 Log Backups
- 1 Clone
- 0 Snapshots Locked

Primary Backup(s)

search

Backup Name	Snapshot Lock Expiration	Count	Type	End Date	Verified	Mounted	RMAN Cataloged	SCN
ora_01_07-18-2024_11.17.20.8165_1		1	Log	07/18/2024 11:17:55 AM	Not Applicable	False	Not Cataloged	2874360
ora_01_07-18-2024_11.17.20.8165_0		1	Data	07/18/2024 11:17:41 AM	Unverified	False	Not Cataloged	2874313
ora_01_07-18-2024_11.09.08.6002_1		1	Log	07/18/2024 11:09:44 AM	Not Applicable	False	Not Cataloged	2873909
ora_01_07-18-2024_11.09.08.6002_0		1	Data	07/18/2024 11:09:30 AM	Unverified	False	Not Cataloged	2873861

Database restore/recovery

SnapCenter provides a number of restore and recovery options for Oracle databases from snapshot backup. In this example, we demonstrate to restore from a older snapshot backup, then roll forward the database to the last available log.

1. First, run a snapshot backup. Then, create a test table and insert a row into table to validate that recovered database from snapshot image before test table creation regains the test table.

```
[oracle@ora_01 ~]$ sqlplus / as sysdba

SQL*Plus: Release 19.0.0.0.0 - Production on Wed Jul 17 10:20:10
2024
Version 19.18.0.0.0

Copyright (c) 1982, 2022, Oracle. All rights reserved.

Connected to:
Oracle Database 19c Enterprise Edition Release 19.0.0.0.0 -
Production
Version 19.18.0.0.0

SQL> sho pdbs

          CON_ID CON_NAME                                OPEN MODE  RESTRICTED
-----
          2 PDB$SEED                                READ ONLY  NO
          3 NTAP1_PDB1                                READ WRITE NO
          4 NTAP1_PDB2                                READ WRITE NO
          5 NTAP1_PDB3                                READ WRITE NO
SQL> alter session set container=ntap1_pdb1;

SQL> select * from test;

no rows selected

SQL> insert into test values (1, sysdate, 'test oracle
backup/restore/clone on VMware Cloud Foundation vVols');

1 row created.

SQL> commit;

Commit complete.

SQL> select * from test;
```

```

ID
-----
DT
-----
EVENT
-----
1
18-JUL-24 11.15.03.000000 AM
test oracle backup/restore/clone on VMware Cloud Foundation vVols

SQL>

```

- From SnapCenter Resources tab, open the database NTAP1 backup topology page. Highlight the snapshot data backup set before the creation of test table. Click on Restore to launch restore-recover workflow.

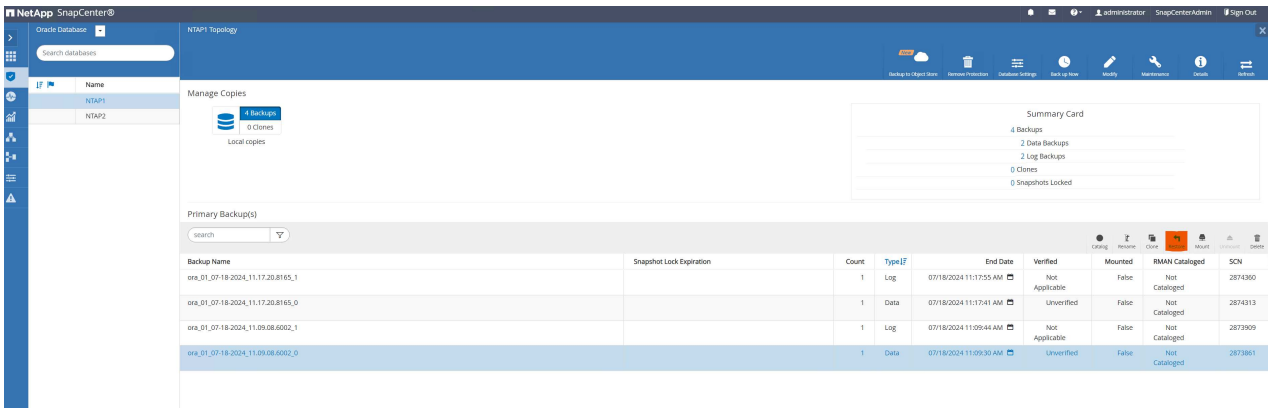

- Choose restore scope.

1 Restore Scope

2 Recovery Scope

3 PreOps

4 PostOps

5 Notification

6 Summary

Restore Scope ⓘ

- All Datafiles
- Pluggable databases (PDBs)
- Pluggable database (PDB) tablespaces

Control files

Database State

Change database state if needed for restore and recovery

Restore Mode ⓘ

Force in place restore

In place restore will skip the foreign files(files which are not part of the database) validation check. The Oracle database and the ASM disk group will be restored to the point when the backup was created.

Previous

Next

4. Choose recovery scope to All Logs.

1 Restore Scope

2 Recovery Scope

3 PreOps

4 PostOps

5 Notification

6 Summary

Choose Recovery Scope

- All Logs ?
- Until SCN (System Change Number)
- Date and Time
- No recovery

Specify external archive log files locations + - ?

Previous

Next

5. Specify any optional pre-scripts to run.

1 Restore Scope

2 Recovery Scope

3 PreOps

4 PostOps

5 Notification

6 Summary

Specify optional scripts to run before performing a restore job ⓘ

Prescript full path Arguments Script timeout

Previous

Next

6. Specify any optional after-script to run.

Restore NTAP1



1 Restore Scope

2 Recovery Scope

3 PreOps

4 PostOps

5 Notification

6 Summary

Specify optional scripts to run after performing a restore job ⓘ

Postscript full path

Arguments

Open the database or container database in READ-WRITE mode after recovery

Previous

Next

7. Send a job report if desired.

Restore NTAP1 ✕

- 1 Restore Scope
- 2 Recovery Scope
- 3 PreOps
- 4 PostOps
- 5 Notification**
- 6 Summary

Provide email settings ⓘ

Email preference

From

To

Subject

Attach job report

8. Review the summary and click on `Finish` to launch the restoration and recovery.

Restore NTAP1



1 Restore Scope

2 Recovery Scope

3 PreOps

4 PostOps

5 Notification

6 Summary

Summary

Backup name	ora_01_07-16-2024_17.39.32.7534_0
Backup date	07/16/2024 5:40:02 PM
Restore scope	All DataFiles
Recovery scope	All Logs
Options	Change database state if necessary , Open the database or container database in READ-WRITE mode after recovery
Prescript full path	None
Prescript arguments	
Postscript full path	None
Postscript arguments	
Send email	No

Previous

Finish

9. From Monitor tab, open the job to review the details.

Job Details



Restore 'ora_01.sddc.netapp.com\NTAP1'

✓ ▾ Restore 'ora_01.sddc.netapp.com\NTAP1'

✓ ▾ ora_01.sddc.netapp.com

- ✓ ▶ Prescripts
- ✓ ▶ Mount log backups
- ✓ ▶ Pre Restore
- ✓ ▶ Restore
- ✓ ▶ Post Restore
- ✓ ▶ Unmount log backups
- ✓ ▶ Postscripts
- ✓ ▶ Post Restore Cleanup
- ✓ ▶ Data Collection
- ✓ ▶ Send EMS Messages

i Task Name: ora_01.sddc.netapp.com Start Time: 07/18/2024 11:26:50 AM End Time: 07/18/2024 11:40:25 AM

View Logs

Cancel Job

Close

10. From DB VM ora_01, validate that a successful restore/recovery of database rolled forward to its most recent state and recovered the test table.

```
[oracle@ora_01 ~]$ sqlplus / as sysdba

SQL*Plus: Release 19.0.0.0.0 - Production on Thu Jul 18 11:42:58
2024
Version 19.18.0.0.0

Copyright (c) 1982, 2022, Oracle. All rights reserved.

Connected to:
Oracle Database 19c Enterprise Edition Release 19.0.0.0.0 -
Production
Version 19.18.0.0.0

SQL> select name, open_mode from v$database;

NAME          OPEN_MODE
-----
NTAP1         READ WRITE

SQL> alter session set container=ntap1_pdb1;

Session altered.

SQL> select * from test;

          ID
-----
DT
-----
EVENT
-----
          1
18-JUL-24 11.15.03.000000 AM
test oracle backup/restore/clone on VMware Cloud Foundation vVols

SQL>
```

In this example, the most recent backup sets is used to clone a database on the DB VM ora_02 in a different software installation and ORACLE_HOME in VCF.

1. Again, open the database NTAP1 backup list. Select the most recent data backup set, click on Clone button to launch database clone workflow.

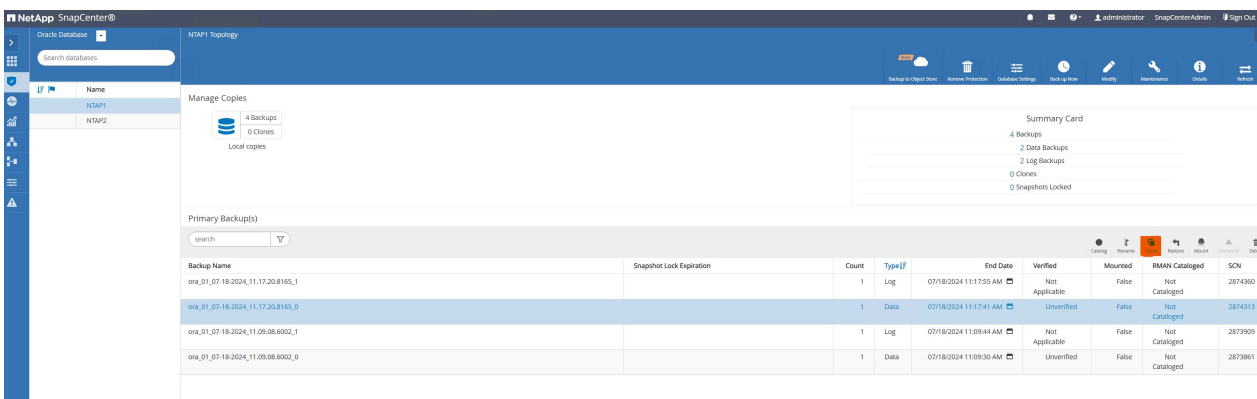

2. Name the clone database SID.

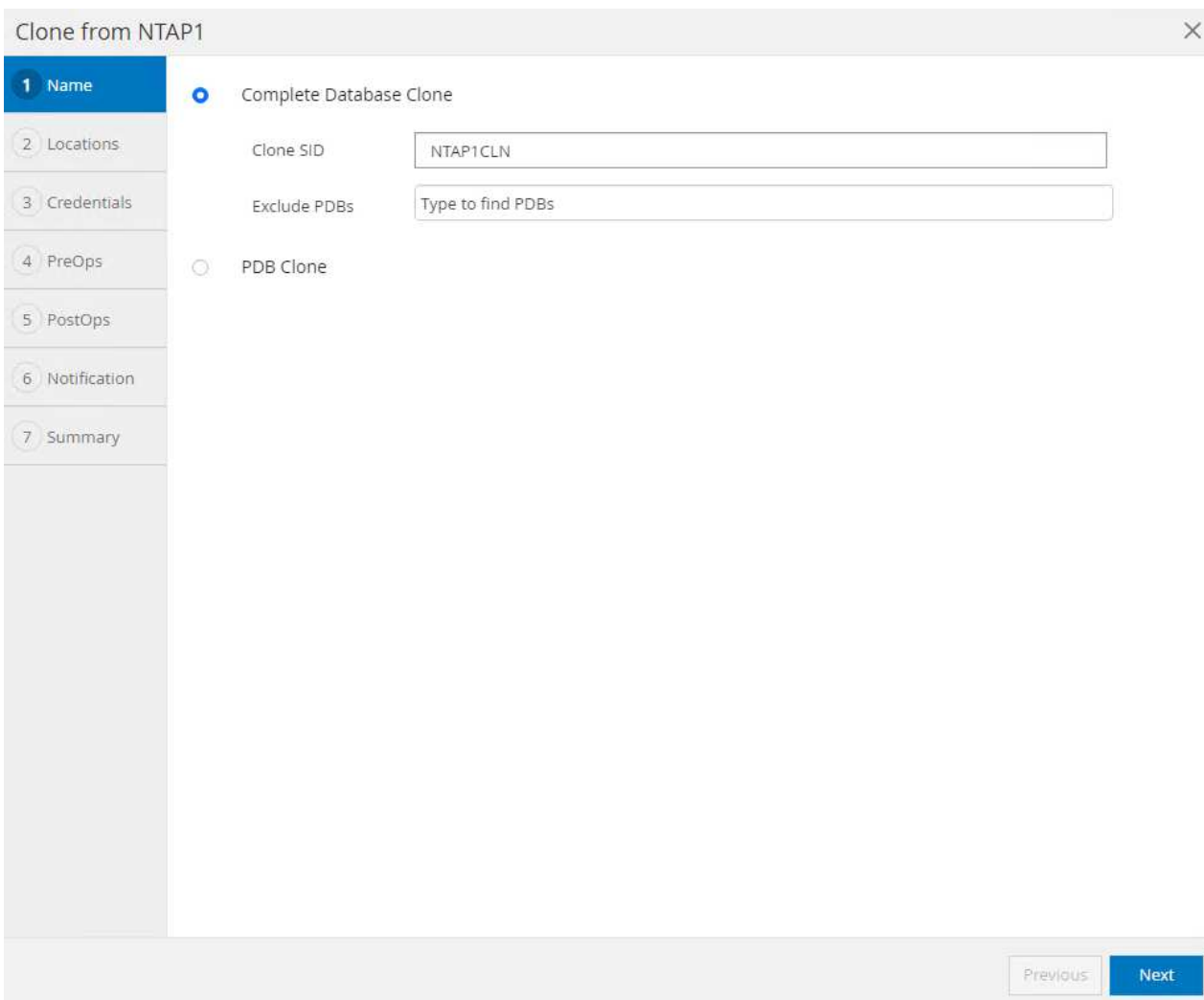

3. Select ora_02 in VCF as the target database clone host. Identical Oracle database software should have been installed and configured on the host.

✕
Clone from NTAP1

- 1 Name
- 2 Locations
- 3 Credentials
- 4 PreOps
- 5 PostOps
- 6 Notification
- 7 Summary

Select the host to create a clone

Clone host

⊖ Datafile locations ℹ

 Reset

⊖ Control files ℹ

/u02_NTAP1CLN/NTAP1CLN/control/control01.ctl	✕	+
/u02_NTAP1CLN/NTAP1CLN/control/control02.ctl	✕	+

Reset

⊖ Redo logs ℹ

Group		Size	Unit	Number of files		
▶ RedoGroup 1	✕	200	MB	1	+	+ Reset
▶ RedoGroup 2	✕	200	MB	1	+	
▶ RedoGroup 3	✕	200	MB	1	+	

Previous
Next

4. Select the proper ORACLE_HOME, user and group on the target host. Keep credential at default.

1 Name

2 Locations

3 Credentials

4 PreOps

5 PostOps

6 Notification

7 Summary

Database Credentials for the clone

Credential name for sys user

None



Database port

1521

Oracle Home Settings i

Oracle Home

/u01/app/oracle/product/19.0.0/NTAP2

Oracle OS User

oracle

Oracle OS Group

oinstall

Previous

Next

5. You may change clone database parameters to meet configuration or resources requirements for the clone database.

1 Name

2 Locations

3 Credentials

4 PreOps

5 PostOps

6 Notification

7 Summary

Specify scripts to run before clone operation ⓘ

Prescript full path Arguments Script timeout

Database Parameter settings

processes	320	✕	▲
remote_login_passwordfile	EXCLUSIVE	✕	+
sga_target	4G	✕	
undo_tablespace	UNDOTBS1	✕	▼

Reset

Previous

Next

6. Choose recovery scope. `Until Cancel` recovers the clone up to last available log file in the backup set.

Clone from NTAP1



1 Name

2 Locations

3 Credentials

4 PreOps

5 PostOps

6 Notification

7 Summary

Recover Database

Until Cancel ?

Date and Time



Date-time format: MM/DD/YYYY hh:mm:ss

Until SCN (System Change Number)



Specify external archive log locations ?

Create new DBID ?

Create tempfile for temporary tablespace ?

Enter SQL queries to apply when clone is created

Enter scripts to run after clone operation ?

Previous

Next

7. Review the summary and launch the clone job.

Clone from NTAP1



1 Name	Summary	
2 Locations	Clone from backup	ora_01_07-18-2024_11.17.20.8165_0
3 Credentials	Clone SID	NTAP1CLN
4 PreOps	Clone server	ora_02.sddc.netapp.com
5 PostOps	Exclude PDBs	none
6 Notification	Oracle home	/u01/app/oracle/product/19.0.0/NTAP2
7 Summary	Oracle OS user	oracle
	Oracle OS group	oinstall
	Datafile mountpaths	/u02_NTAP1CLN
	Control files	/u02_NTAP1CLN/NTAP1CLN/control/control01.ctl /u02_NTAP1CLN/NTAP1CLN/control/control02.ctl
	Redo groups	RedoGroup =1 TotalSize =200 Path =/u02_NTAP1CLN/NTAP1CLN/redolog/redo01_01.log RedoGroup =2 TotalSize =200 Path =/u02_NTAP1CLN/NTAP1CLN/redolog/redo02_01.log RedoGroup =3 TotalSize =200 Path =/u02_NTAP1CLN/NTAP1CLN/redolog/redo03_01.log
	Recovery scope	Until Cancel
	Prescript full path	none
	Prescript arguments	
	Postscript full path	none
	Postscript arguments	
	Send email	No

Previous

Finish

8. Monitor the clone job execution from **Monitor** tab.

Job Details



Clone from backup 'ora_01_07-18-2024_11.17.20.8165_0'

✔ ▼ Clone from backup 'ora_01_07-18-2024_11.17.20.8165_0'

✔ ▼ ora_02.sddc.netapp.com

- ✔ ▶ Prescripts
- ✔ ▶ Query Host Information
- ✔ ▶ Prepare for Cloning
- ✔ ▶ Cloning Resources
- ✔ ▶ FileSystem Clone
- ✔ ▶ Application Clone
- ✔ ▶ Postscripts
- ✔ ▶ Register Clone
- ✔ ▶ Unmount Clone
- ✔ ▶ Data Collection

📌 Task Name: ora_02.sddc.netapp.com Start Time: 07/18/2024 11:50:41 AM End Time: 07/18/2024 12:02:34 PM

View Logs

Cancel Job

Close

9. Cloned database is immediately registered in SnapCenter.

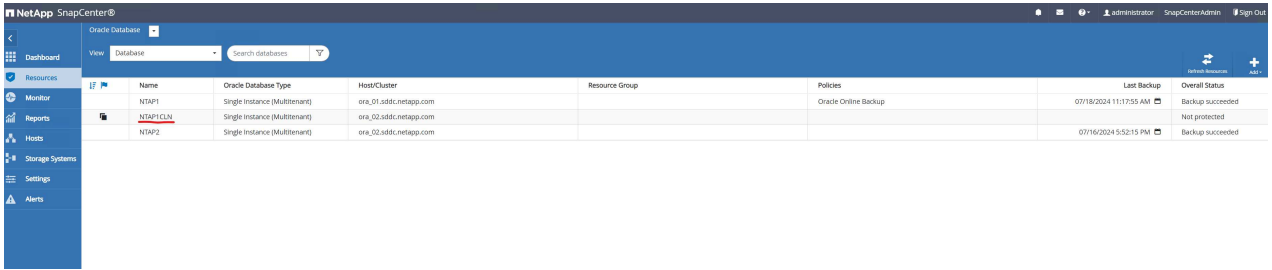

The screenshot shows the NetApp SnapCenter interface. The main content area displays a table with the following data:

Name	Oracle Database Type	Host/Cluster	Resource Group	Policies	Last Backup	Overall Status
NTAP1	Single Instance (Multitenant)	ora_01.adfnc.netapp.com		Oracle Online Backup	07/18/2024 11:17:55 AM	Backup succeeded
NTAP1CLN	Single Instance (Multitenant)	ora_02.adfnc.netapp.com				Not protected
NTAP2	Single Instance (Multitenant)	ora_02.adfnc.netapp.com			07/16/2024 5:52:15 PM	Backup succeeded

10. From DB VM ora_02, validate the cloned database and query the test table.

```
[oracle@ora_02 ~]$ sqlplus / as sysdba

SQL*Plus: Release 19.0.0.0.0 - Production on Thu Jul 18 12:06:48
2024
Version 19.18.0.0.0

Copyright (c) 1982, 2022, Oracle. All rights reserved.

Connected to:
Oracle Database 19c Enterprise Edition Release 19.0.0.0.0 -
Production
Version 19.18.0.0.0

SQL> select name, open_mode, log_mode from v$database;

NAME          OPEN_MODE          LOG_MODE
-----
NTAP1CLN     READ WRITE          ARCHIVELOG

SQL> select instance_name, host_name from v$instance;

INSTANCE_NAME
-----
HOST_NAME
-----
NTAP1CLN
ora_02

SQL> show pdbs

CON_ID CON_NAME          OPEN MODE RESTRICTED
-----
2 PDB$SEED          READ ONLY NO
```



```

        3 NTAP1_PDB1                READ WRITE NO
        4 NTAP1_PDB2                READ WRITE NO
        5 NTAP1_PDB3                READ WRITE NO
SQL> alter session set container=ntap1_pdb1
      2 ;

Session altered.

SQL> select * from test;

          ID
-----
DT
-----
EVENT
-----
          1
18-JUL-24 11.15.03.000000 AM
test oracle backup/restore/clone on VMware Cloud Foundation vVols

SQL>

```

This completes the demonstration of SnapCenter backup, restore, and clone of Oracle database in VCF.

Where to find additional information

To learn more about the information described in this document, review the following documents and/or websites:

- VMware Cloud Foundation

<https://www.vmware.com/products/cloud-infrastructure/vmware-cloud-foundation>

- NetApp Enterprise Database Solutions

<https://docs.netapp.com/us-en/netapp-solutions/databases/index.html>

- SnapCenter Software 6.0

https://docs.netapp.com/us-en/snapcenter/concept/concept_snapcenter_overview.html

TR-4992: Simplified, Automated Oracle Deployment on NetApp C-Series with NFS

Allen Cao, Niyaz Mohamed, NetApp

This solution provides an overview and details for automated Oracle deployment in NetApp AFF C-Series as primary database storage with NFS protocol. The Oracle database deploys as a container database with dNFS enabled.

Purpose

NetApp AFF C-Series is a capacity flash storage that makes all-flash more accessible and affordable for unified storage. It is sufficient performance-wise for many tier 1 or tier 2 Oracle database workloads. Powered by NetApp ONTAP® data management software, AFF C-Series systems deliver industry-leading efficiency, superior flexibility, best-in-class data services, and cloud integration to help you scale your IT infrastructure, simplify your data management, and reduce storage cost and power consumption.

This documentation demonstrates the simplified deployment of Oracle databases in NetApp C-Series via NFS mounts using Ansible automation. The Oracle database deploys in a container database (CDB) and pluggable databases (PDB) configuration with Oracle dNFS protocol enabled to boost performance. Furthermore, the solution provides the best practices in setting up storage networking and storage virtual machine (SVM) with NFS protocol on C-Series storage controllers. The solution also includes information on fast Oracle database backup, restore, and clone with the NetApp SnapCenter UI tool.

This solution addresses the following use cases:

- Automated Oracle container database deployment on NetApp C-Series storage controllers.
- Oracle database protection and clone on C-Series with SnapCenter UI tool.

Audience

This solution is intended for the following people:

- A DBA who would like to deploy Oracle on NetApp C-Series.
- A database solution architect who would like to test Oracle workloads on NetApp C-Series.
- A storage administrator who would like to deploy and manage an Oracle database on NetApp C-Series.
- An application owner who would like to stand up an Oracle database on NetApp C-Series.

Solution test and validation environment

The testing and validation of this solution were performed in a lab setting that might not match the final deployment environment. See the section [Key factors for deployment consideration](#) for more information.

Architecture

Simplified, Automated Oracle Database Deployment on NetApp C-Series with NFS

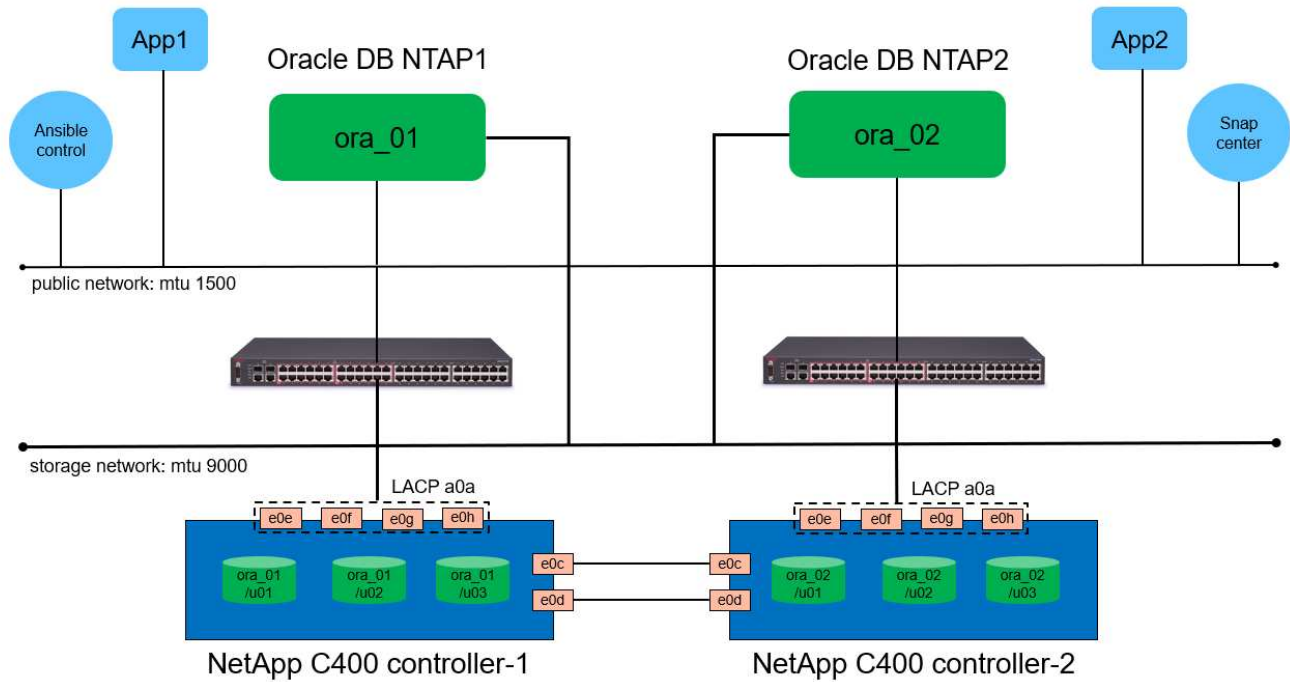

Hardware and software components

Hardware

NetApp C-Series C400	ONTAP Version 9.13.1P3	Two disk shelves / 24 disks with 278 TiB capacity
VM for DB server	4 vCPUs, 16GiB RAM	Two Linux VM instances for concurrent deployment
VM for SnapCenter	4 vCPUs, 16GiB RAM	One Windows VM instance

Software

RedHat Linux	RHEL Linux 8.6 (LVM) - x64 Gen2	Deployed RedHat subscription for testing
Windows Server	2022 DataCenter x64 Gen2	Hosting SnapCenter server
Oracle Database	Version 19.18	Applied RU patch p34765931_190000_Linux-x86-64.zip
Oracle OPatch	Version 12.2.0.1.36	Latest patch p6880880_190000_Linux-x86-64.zip
SnapCenter Server	Version 5.0	Workgroup deployment
Open JDK	Version java-11-openjdk	SnapCenter plugin requirement on DB VMs
NFS	Version 3.0	Oracle dNFS enabled
Ansible	core 2.16.2	Python 3.6.8

Oracle database configuration in the lab environment

Server	Database	DB Storage
ora_01	NTAP1(NTAP1_PDB1,NTAP1_PDB2,NTAP1_PDB3)	/u01, /u02, /u03 NFS mounts on C400 volumes
ora_02	NTAP2(NTAP2_PDB1,NTAP2_PDB2,NTAP2_PDB3)	/u01, /u02, /u03 NFS mounts on C400 volumes

Key factors for deployment consideration

- **Oracle database storage layout.** In this automated Oracle deployment, we provision three database volumes for each database to host Oracle binary, data, and logs by default. The volumes are mounted on Oracle DB server as /u01 - binary, /u02 - data, /u03 - logs via NFS. Dual control files are configured on /u02 and /u03 mount points for redundancy.
- **Multiple DB servers deployment.** The automation solution can deploy an Oracle container database to multiple DB servers in a single Ansible playbook run. Regardless of the number of DB servers, the playbook execution remains the same. You can deploy multiple container databases to a single VM instance by repeating the deployment with different database instance IDs (Oracle SID). But ensure there is sufficient memory on the host to support deployed databases.
- **dNFS configuration.** By using dNFS (available since Oracle 11g), an Oracle database running on a DB VM can drive significantly more I/O than the native NFS client. Automated Oracle deployment configures dNFS on NFSv3 by default.
- **Load balancing on C400 controller pair.** Place Oracle database volumes on C400 controller nodes evenly to balance the workload. DB1 on controller 1, DB2 on controller 2, and so on. Mount the DB volumes to its local lif address.
- **Database backup.** NetApp provides a SnapCenter software suite for database backup, restore, and cloning with a user-friendly UI interface. NetApp recommends implementing such a management tool to achieve fast (under a minute) snapshot backup, quick (minutes) database restore, and database clone.

Solution deployment

The following sections provide step-by-step procedures for automated Oracle 19c deployment and information for Oracle database protection and clone after deployment.

Prerequisites for deployment

Deployment requires the following prerequisites.

1. A NetApp C-Series storage controller pair is racked, stacked, and latest version of ONTAP operating system is installed and configured. Refer to this setup guide as necessary: [Detailed guide - AFF C400](#)
2. Provision two Linux VMs as Oracle DB servers. See the architecture diagram in the previous section for details about the environment setup.
3. Provision a Windows server to run the NetApp SnapCenter UI tool with the latest version. Refer to the following link for details: [Install the SnapCenter Server](#)
4. Provision a Linux VM as the Ansible controller node with the latest version of Ansible and Git installed. Refer to the following link for details: [Getting Started with NetApp solution automation in section -](#)

Setup the Ansible Control Node for CLI deployments on RHEL / CentOS or
Setup the Ansible Control Node for CLI deployments on Ubuntu / Debian.

Enable ssh public/private key authentication between Ansible controller and database VMs.

5. From Ansible controller admin user home directory, clone a copy of the NetApp Oracle deployment automation toolkit for NFS.

```
git clone https://bitbucket.ngage.netapp.com/scm/ns-  
bb/na_oracle_deploy_nfs.git
```

6. Stage following Oracle 19c installation files on DB VM /tmp/archive directory with 777 permission.

```
installer_archives:  
- "LINUX.X64_193000_db_home.zip"  
- "p34765931_190000_Linux-x86-64.zip"  
- "p6880880_190000_Linux-x86-64.zip"
```

Configure Networking and SVM on C-Series for Oracle

This section of deployment guide demonstrates best practices to set up networking and storage virtual machine (SVM) on C-Series controller for Oracle workload with NFS protocol using ONTAP System Manager UI.

1. Login to ONTAP System Manager to review that after initial ONTAP cluster installation, broadcast domains have been configured with ethernet ports properly assigned to each domain. Generally, there should be a broadcast domain for cluster, a broadcast domain for management, and a broadcast domain for workload such as data.

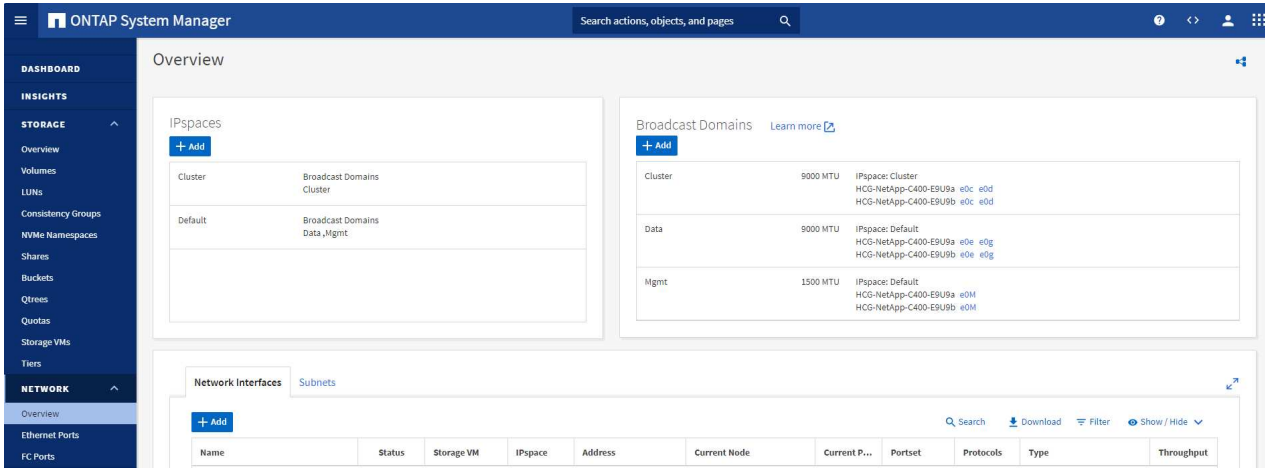

2. From NETWORK - Ethernet Ports, click `Link Aggregate Group` to create a LACP link aggregate group port `a0a`, which provides load balance and failover among the member ports in the aggregate group port. There are 4 data ports - `e0e`, `e0f`, `e0g`, `e0h` available on C400 controllers.

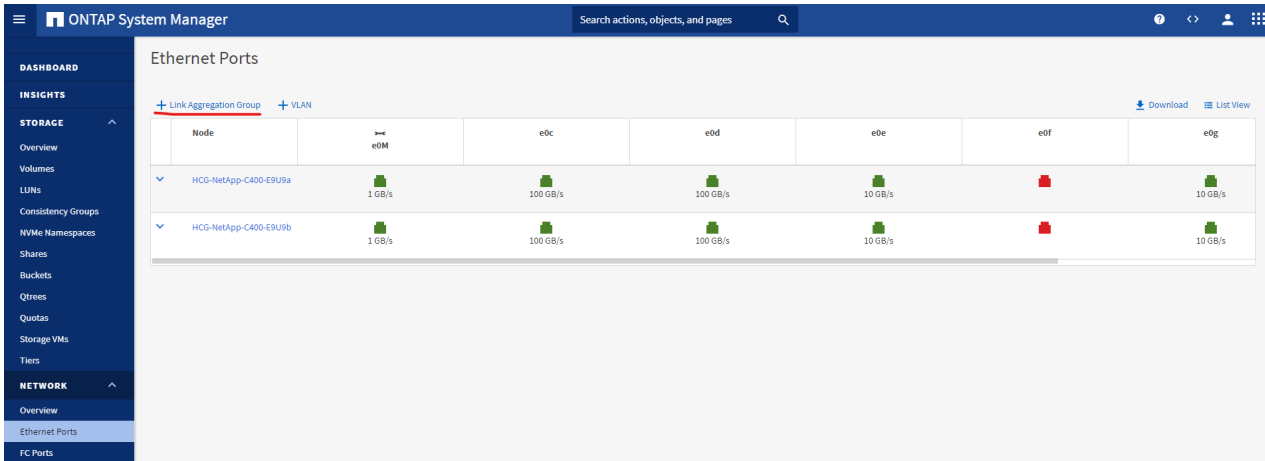

3. Select the ethernet ports in the group, `LACP` for mode, and `Port` for load distribution.

Add Link Aggregation Group



NODE

HCG-NetApp-C400-E9U9a

BROADCAST DOMAIN

Automatically select a broadcast domain (recommended)

PORTS TO INCLUDE

The following ports are down: e0f, e0h.

e0e e0f e0g e0h

MODE

- Single
Only one port is used at a time.
- Multiple
All ports can be used simultaneously.
- LACP
The LACP protocol determines the ports that can be used.

LOAD DISTRIBUTION

- IP based
Network traffic is distributed based on the destination IP address.
- MAC based
Network traffic is distributed based on the next-hop MAC addresses.
- Sequential
Network traffic is distributed by round-robin over the outbound links.
- Port
Network traffic is distributed based on the transport layer (TCP/UDP) ports.

Save

Cancel

4. Validate LACP port a0a created and broadcast domain Data is now operating on LACP port.

The screenshot shows the ONTAP System Manager interface. The left sidebar contains navigation options: DASHBOARD, INSIGHTS, STORAGE, NETWORK (expanded), Overview, Ethernet Ports, FC Ports, EVENTS & JOBS, PROTECTION, HOSTS, and CLUSTER. The main content area is titled "Ethernet Ports" and displays a table with columns for Node, a0a, e0M, e0c, and e0d. Two nodes are listed: HCG-NetApp-C400-E9U9b and HCG-NetApp-C400-E9U9a. Each node has a green status icon and throughput values for each port.

Node	a0a	e0M	e0c	e0d
HCG-NetApp-C400-E9U9b		1 GB/s	100 GB/s	100 GB/s
HCG-NetApp-C400-E9U9a		1 GB/s	100 GB/s	100 GB/s

ONTAP System Manager Search actions, objects, and pages

DASHBOARD

INSIGHTS

STORAGE ▾

NETWORK ▾

Overview

Ethernet Ports

FC Ports

EVENTS & JOBS ▾

PROTECTION ▾

HOSTS ▾

CLUSTER ▾

Overview

IPspaces [+ Add](#)

Cluster	Broadcast Domains Cluster
Default	Broadcast Domains Data ,Mgmt

Broadcast Domains [Learn more](#) [+ Add](#)

Cluster	9000 MTU	IPspace: Cluster HCG-NetApp-C400-E9U9a e0c e0d HCG-NetApp-C400-E9U9b e0c e0d
Data	9000 MTU	IPspace: Default HCG-NetApp-C400-E9U9a a0a HCG-NetApp-C400-E9U9b a0a
Mgmt	1500 MTU	IPspace: Default HCG-NetApp-C400-E9U9a e0M

- From Ethernet Ports, click VLAN to add a VLAN on each controller node for Oracle workload on NFS protocol.

Add VLAN



NODE

HCG-NetApp-C400-E9U9a



BROADCAST DOMAIN

Automatically select a broadcast domain (recommended)



PORT

a0a



VLAN ID

3277

Cancel

Save

ONTAP System Manager Search actions, objects, and pages

Ethernet Ports

+ Link Aggregation Group + VLAN Download List View

Node	a0a	a0a-3277	e0M	e0c
HCG-NetApp-C400-E9U9b 			1 GB/s	100 GB/s
HCG-NetApp-C400-E9U9a 			1 GB/s	100 GB/s

ONTAP System Manager Search actions, objects, and pages

Overview

IPspaces

+ Add

Cluster	Broadcast Domains
Cluster	Cluster
Default	Data, Mgmt

Broadcast Domains

Learn more

+ Add

Cluster	9000 MTU	IPspace: Cluster
HCG-NetApp-C400-E9U9a		e0c e0d
HCG-NetApp-C400-E9U9b		e0c e0d
Data	9000 MTU	IPspace: Default
HCG-NetApp-C400-E9U9a		a0a a0a-3277
HCG-NetApp-C400-E9U9b		a0a a0a-3277
Mgmt	1500 MTU	IPspace: Default
HCG-NetApp-C400-E9U9a		e0M

6. Login to C-Series controllers from cluster management IP via ssh to validate that network failover groups are configured correctly. ONTAP create and manage failover groups automatically.

```

HCG-NetApp-C400-E9U9::> net int failover-groups show
(network interface failover-groups show)
                                Failover
Vserver          Group          Targets
-----
Cluster
                Cluster
                                HCG-NetApp-C400-E9U9a:e0c,
                                HCG-NetApp-C400-E9U9a:e0d,
                                HCG-NetApp-C400-E9U9b:e0c,
                                HCG-NetApp-C400-E9U9b:e0d
HCG-NetApp-C400-E9U9
                Data
                                HCG-NetApp-C400-E9U9a:a0a,
                                HCG-NetApp-C400-E9U9a:a0a-3277,
                                HCG-NetApp-C400-E9U9b:a0a,
                                HCG-NetApp-C400-E9U9b:a0a-3277
                Mgmt
                                HCG-NetApp-C400-E9U9a:e0M,
                                HCG-NetApp-C400-E9U9b:e0M
3 entries were displayed.

```

7. From STORAGE - Storage VMs, click +Add to create a SVM for Oracle.

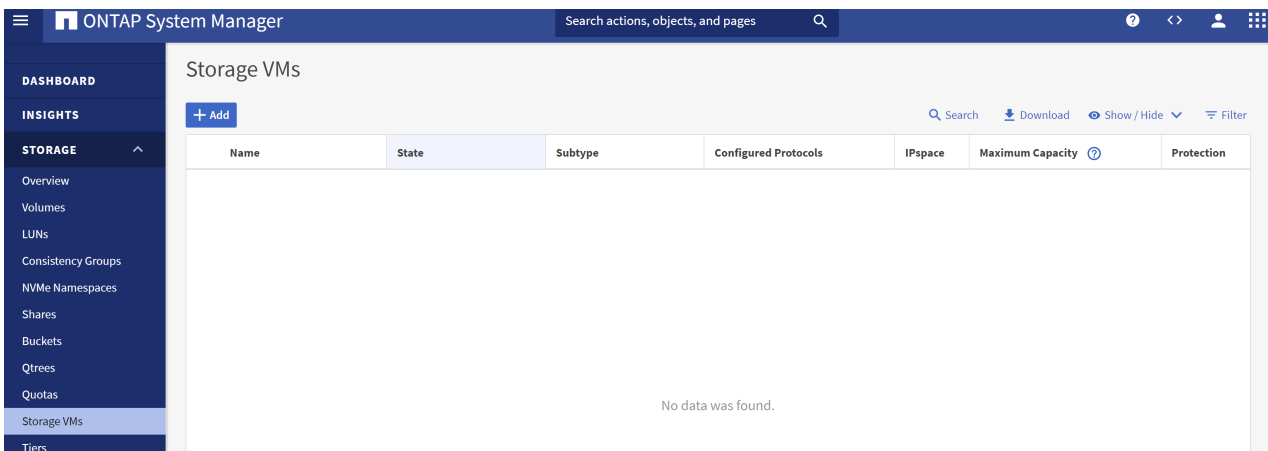

8. Name your Oracle SVM, check Enable NFS and Allow NFS client access.

Add Storage VM



STORAGE VM NAME

oracle

Access Protocol

SMB/CIFS, NFS, S3 [iSCSI](#) [FC](#) [NVMe](#)

Enable SMB/CIFS

Enable NFS

Allow NFS client access

Add at least one rule to allow NFS clients to access volumes in this storage VM. [?](#)

EXPORT POLICY

Default

RULES

No data

[+](#) Add

Enable S3

DEFAULT LANGUAGE [?](#)

c.utf_8

9. Add NFS export policy Default rules.

New Rule



CLIENT SPECIFICATION

172.21.21.0/255.255.255.0

ACCESS PROTOCOLS

SMB/CIFS

FlexCache

NFS NFSv3 NFSv4

ACCESS DETAILS

Type	Read-only Access	Read/Write Access	Superuser Access
All	<input type="checkbox"/>	<input type="checkbox"/>	<input type="checkbox"/>
All (As anonymous user) 	<input type="checkbox"/>	<input type="checkbox"/>	<input type="checkbox"/>
UNIX	<input checked="" type="checkbox"/>	<input checked="" type="checkbox"/>	<input checked="" type="checkbox"/>
Kerberos 5	<input type="checkbox"/>	<input type="checkbox"/>	<input type="checkbox"/>
Kerberos 5i	<input type="checkbox"/>	<input type="checkbox"/>	<input type="checkbox"/>
Kerberos 5p	<input type="checkbox"/>	<input type="checkbox"/>	<input type="checkbox"/>
NTLM	<input type="checkbox"/>	<input type="checkbox"/>	<input type="checkbox"/>

Cancel

Save

10. In NETWORK INTERFACE, fill in IP address on each node for NFS lif addresses.

NETWORK INTERFACE

Use multiple network interfaces when client traffic is high.

HCG-NetApp-C400-E9U9a

IP ADDRESS

172.21.21.100

SUBNET MASK

255.255.255.0

GATEWAY

[Add optional gateway](#)

BROADCAST DOMAIN AND PORT

Data

Use the same subnet mask and gateway for all of the following interfaces

HCG-NetApp-C400-E9U9b

IP ADDRESS

172.21.21.101

SUBNET MASK

255.255.255.0

GATEWAY

[Add optional gateway](#)

BROADCAST DOMAIN AND PORT

Data

Storage VM Administration

- Enable maximum capacity limit
The maximum capacity that all volumes in this storage VM can allocate. [Learn More](#)
- Manage administrator account

Save

Cancel

11. Validate SVM for Oracle is up/running and NFS lifs status is active.

The screenshot shows the ONTAP System Manager interface. The left sidebar is expanded to 'STORAGE' > 'Storage VMs'. The main content area displays a table of Storage VMs. One VM named 'oracle' is listed with the following details:

Name	State	Subtype	Configured Protocols	IPspace	Maximum Capacity	Protection
oracle	running	default	NFS	Default	The maximum capacity is disabled	

Network Interfaces [Subnets](#)

[+ Add](#) [Search](#) [Download](#) [Filter](#) [Show / Hide](#)

Name	Status	Storage VM	IPspace	Address	Current Node	Current P...	Portset	Protocols	T
HCG-NetApp-C400-E9U9a_clu s1	✔		Cluster	169.254.47.43	HCG-NetApp-C400-E9U9a	e0c			C
HCG-NetApp-C400-E9U9b_clu s1	✔		Cluster	169.254.152.124	HCG-NetApp-C400-E9U9b	e0c			C
HCG-NetApp-C400-E9U9b_clu s2	✔		Cluster	169.254.107.230	HCG-NetApp-C400-E9U9b	e0d			C
HCG-NetApp-C400-E9U9b_mg mt1	✔		Default	10.61.180.109	HCG-NetApp-C400-E9U9b	e0M			C
lif_oracle_145	✔	oracle	Default	172.21.21.100	HCG-NetApp-C400-E9U9a	a0a-3277		NFS	D
lif_oracle_37	✔	oracle	Default	172.21.21.101	HCG-NetApp-C400-E9U9b	a0a-3277		NFS	D

Showing 1 - 9 of 9 Network Interfaces [←](#) **1** [→](#)

12. From STORAGE-Volumes tab to add NFS volumes for Oracle database.

ONTAP System Manager [Search actions, objects, and pages](#)

Volumes [+ Add](#) [More](#) [Search](#) [Download](#) [Show / Hide](#) [Filter](#)

Name	Storage VM	Status	Capacity	IOPS	Latency (ms)	Throughput (MB/s)	Protection
oracle_root	oracle	✔ Online	<div style="display: flex; align-items: center;"> <div style="width: 292px; height: 10px; background-color: #ccc; margin-right: 5px;"></div> <div style="width: 973px; height: 10px; background-color: #ccc; margin-right: 5px;"></div> <div style="width: 100px; height: 10px; background-color: #0070c0; margin-right: 5px;"></div> 1 GiB </div> <div style="font-size: 8px; margin-top: 2px;"> 292 MiB used 973 MiB available </div>	0	0	0	✔ ☁

13. Name your volume, assign capacity, and performance level.

Add Volume



NAME

ora_01_u01

- Add as a cache for a remote volume (FlexCache)
Simplifies file distribution, reduces WAN latency, and lowers WAN bandwidth costs.

Storage and Optimization

CAPACITY

50

GiB



PERFORMANCE SERVICE LEVEL

Performance



Not sure? [Get help selecting type](#)

OPTIMIZATION OPTIONS

- Distribute volume data across the cluster (FlexGroup) 

14. In `Access Permission`, choose the default policy created from previous step. Uncheck `Enable Snapshot Copies` as we prefer to use SnapCenter to create application consistent snapshots.

Access Permissions

Export via NFS

GRANT ACCESS TO HOST

default

Create a new export policy, or select an existing export policy.

Rule Index	Clients	Access Protocols	Read-Only Rule	Read/W
1	172.21.21.0/255.255.255.0	NFSv3, NFSv4, NFS	Sys	Sys

SnapLock

[SnapLock Considerations](#)

Enable SnapLock

With SnapLock, files can be stored and committed to a non-erasable, non-rewritable state either forever or for a designated retention period.

Protection

Enable Snapshot Copies (Local)

Enable Snapshot locking [i](#)

Enables the ability to lock Snapshot copies that were created either manually or by Snapshot policies. The Snapshot copies are locked only when a retention period is specified.

Enable SnapMirror (Local or Remote)

Save

Cancel

[Save to Ansible Playbook](#)

15. Create three DB volumes for each DB server: `server_name_u01` - binary, `server_name_u02` - data, `server_name_u03` - logs.

The screenshot shows the ONTAP System Manager interface. The left sidebar has a 'STORAGE' menu with 'Volumes' selected. The main area displays a table of volumes for the 'oracle' storage VM. The table has columns for Name, Storage VM, Status, Capacity, IOPS, Latency (ms), Throughput (MB/s), and Protection. There are four volumes listed: 'oracle_root' (1 GiB), 'ora_01_u01' (50 GiB), 'ora_01_u02' (200 GiB), and 'ora_01_u03' (100 GiB). All are 'Online'.

Name	Storage VM	Status	Capacity	IOPS	Latency (ms)	Throughput (MB/s)	Protection
oracle_root	oracle	Online	360 KiB used / 972 MiB available / 1 GiB	0	0	0	✓
ora_01_u01	oracle	Online	304 KiB used / 50 GiB available / 50 GiB	0	0	0	✓
ora_01_u02	oracle	Online	308 KiB used / 200 GiB available / 200 GiB	0	0	0	✓
ora_01_u03	oracle	Online	308 KiB used / 100 GiB available / 100 GiB	0	0	0	✓



The DB volume naming convention should strictly follow format as stated above to ensure automation to work correctly.

This completes the C-series controller configuration for Oracle.

Automation parameter files

Ansible playbook executes database installation and configuration tasks with predefined parameters. For this Oracle automation solution, there are three user-defined parameter files that need user input before playbook execution.

- `hosts` - define targets that the automation playbook is running against.
- `vars/vars.yml` - the global variable file that defines variables that apply to all targets.
- `host_vars/host_name.yml` - the local variable file that defines variables that apply only to a named target. In our use case, these are the Oracle DB servers.

In addition to these user-defined variable files, there are several default variable files that contain default parameters that do not require change unless necessary. The following sections show how to configure the user-defined variable files.

Parameter files configuration

1. Ansible target `hosts` file configuration:

```
# Enter Oracle servers names to be deployed one by one, follow by
each Oracle server public IP address, and ssh private key of admin
user for the server.
[oracle]
ora_01 ansible_host=10.61.180.21 ansible_ssh_private_key_file
=ora_01.pem
ora_02 ansible_host=10.61.180.23 ansible_ssh_private_key_file
=ora_02.pem
```

2. Global vars/`vars.yml` file configuration

```

#####
##
##### Oracle 19c deployment user configuration variables
#####
##### Consolidate all variables from ONTAP, linux and oracle
#####
#####
#####

#####
### ONTAP env specific config variables ###
#####

# Prerequisite to create three volumes in NetApp ONTAP storage from
System Manager or cloud dashboard with following naming convention:
# db_hostname_u01 - Oracle binary
# db_hostname_u02 - Oracle data
# db_hostname_u03 - Oracle redo
# It is important to strictly follow the name convention or the
automation will fail.

#####
### Linux env specific config variables ###
#####

redhat_sub_username: XXXXXXXXX
redhat_sub_password: XXXXXXXXX

#####
### DB env specific install and config variables ###
#####

# Database domain name
db_domain: solutions.netapp.com

# Set initial password for all required Oracle passwords. Change
them after installation.
initial_pwd_all: XXXXXXXXX

```

3. Local DB server host_vars/host_name.yml configuration such as ora_01.yml, ora_02.yml ...

```
# User configurable Oracle host specific parameters

# Enter container database SID. By default, a container DB is
created with 3 PDBs within the CDB
oracle_sid: NTAP1

# Enter database shared memory size or SGA. CDB is created with SGA
at 75% of memory_limit, MB. The grand total of SGA should not exceed
75% available RAM on node.
memory_limit: 8192

# Local NFS lif ip address to access database volumes
nfs_lif: 172.30.136.68
```

Playbook execution

There are a total of five playbooks in the automation toolkit. Each performs different task blocks and serves different purposes.

```
0-all_playbook.yml - execute playbooks from 1-4 in one playbook run.
1-ansible_requirements.yml - set up Ansible controller with required
libs and collections.
2-linux_config.yml - execute Linux kernel configuration on Oracle DB
servers.
4-oracle_config.yml - install and configure Oracle on DB servers and
create a container database.
5-destroy.yml - optional to undo the environment to dismantle all.
```

There are three options to run the playbooks with the following commands.

1. Execute all deployment playbooks in one combined run.

```
ansible-playbook -i hosts 0-all_playbook.yml -u admin -e
@vars/vars.yml
```

2. Execute playbooks one at a time with the number sequence from 1-4.

```
ansible-playbook -i hosts 1-ansible_requirements.yml -u admin -e
@vars/vars.yml
```

```
ansible-playbook -i hosts 2-linux_config.yml -u admin -e
@vars/vars.yml
```

```
ansible-playbook -i hosts 4-oracle_config.yml -u admin -e
@vars/vars.yml
```

3. Execute 0-all_playbook.yml with a tag.

```
ansible-playbook -i hosts 0-all_playbook.yml -u admin -e
@vars/vars.yml -t ansible_requirements
```

```
ansible-playbook -i hosts 0-all_playbook.yml -u admin -e
@vars/vars.yml -t linux_config
```

```
ansible-playbook -i hosts 0-all_playbook.yml -u admin -e  
@vars/vars.yml -t oracle_config
```

4. Undo the environment

```
ansible-playbook -i hosts 5-destroy.yml -u admin -e @vars/vars.yml
```

Post execution validation

After the playbook run, login to the Oracle DB server VM to validate that Oracle is installed and configured and a container database is created successfully. Following is an example of Oracle database validation on DB VM ora_01 or ora_02.

1. Validate NFS mounts

```
[admin@ora_01 ~]$ cat /etc/fstab

#
# /etc/fstab
# Created by anaconda on Wed Oct 18 19:43:31 2023
#
# Accessible filesystems, by reference, are maintained under
# '/dev/disk/'.
# See man pages fstab(5), findfs(8), mount(8) and/or blkid(8) for
# more info.
#
# After editing this file, run 'systemctl daemon-reload' to update
# systemd
# units generated from this file.
#
/dev/mapper/rhel-root / xfs defaults
0 0
UUID=aff942c4-b224-4b62-807d-6a5c22f7b623 /boot
xfs defaults 0 0
/dev/mapper/rhel-swap none swap defaults
0 0
/root/swapfile swap swap defaults 0 0
172.21.21.100:/ora_01_u01 /u01 nfs
rw,bg,hard,vers=3,proto=tcp,timeo=600,rsize=65536,wsiz=65536 0 0
172.21.21.100:/ora_01_u02 /u02 nfs
rw,bg,hard,vers=3,proto=tcp,timeo=600,rsize=65536,wsiz=65536 0 0
172.21.21.100:/ora_01_u03 /u03 nfs
rw,bg,hard,vers=3,proto=tcp,timeo=600,rsize=65536,wsiz=65536 0 0

[admin@ora_01 tmp]$ df -h
Filesystem              Size  Used Avail Use% Mounted on
devtmpfs                7.7G   0  7.7G   0% /dev
tmpfs                   7.8G   0  7.8G   0% /dev/shm
tmpfs                   7.8G  18M  7.8G   1% /run
tmpfs                   7.8G   0  7.8G   0% /sys/fs/cgroup
/dev/mapper/rhel-root   44G   28G  17G  62% /
/dev/sda1               1014M 258M  757M  26% /boot
tmpfs                   1.6G  12K  1.6G   1% /run/user/42
tmpfs                   1.6G  4.0K  1.6G   1% /run/user/1000
```

```
172.21.21.100:/ora_01_u01 50G 8.7G 42G 18% /u01
172.21.21.100:/ora_01_u02 200G 384K 200G 1% /u02
172.21.21.100:/ora_01_u03 100G 320K 100G 1% /u03
```

```
[admin@ora_02 ~]$ df -h
Filesystem                Size      Used Avail Use% Mounted on
devtmpfs                  7.7G         0  7.7G   0% /dev
tmpfs                     7.8G         0  7.8G   0% /dev/shm
tmpfs                     7.8G      18M  7.8G   1% /run
tmpfs                     7.8G         0  7.8G   0% /sys/fs/cgroup
/dev/mapper/rhel-root     44G       28G  17G  63% /
/dev/sda1                 1014M    258M  757M  26% /boot
tmpfs                     1.6G      12K  1.6G   1% /run/user/42
tmpfs                     1.6G     4.0K  1.6G   1% /run/user/1000
172.21.21.101:/ora_02_u01 50G   7.8G   43G  16% /u01
172.21.21.101:/ora_02_u02 200G   320K  200G   1% /u02
172.21.21.101:/ora_02_u03 100G   320K  100G   1% /u03
```

2. Validate Oracle listener

```
[admin@ora_02 ~]$ sudo su
[root@ora_02 admin]# su - oracle
[oracle@ora_02 ~]$ lsnrctl status listener.ntap2

LSNRCTL for Linux: Version 19.0.0.0.0 - Production on 29-MAY-2024
12:13:30

Copyright (c) 1991, 2022, Oracle. All rights reserved.

Connecting to
 (DESCRIPTION=(ADDRESS=(PROTOCOL=TCP) (HOST=ora_02.cie.netapp.com) (PORT=1521)))
STATUS of the LISTENER
-----
Alias                     LISTENER.NTAP2
Version                   TNSLSNR for Linux: Version 19.0.0.0.0 -
Production
Start Date                 23-MAY-2024 16:13:03
Uptime                     5 days 20 hr. 0 min. 26 sec
Trace Level                off
Security                   ON: Local OS Authentication
SNMP                       OFF
Listener Parameter File
/u01/app/oracle/product/19.0.0/NTAP2/network/admin/listener.ora
Listener Log File
```



```

/u01/app/oracle/diag/tnslsnr/ora_02/listener.ntap2/alert/log.xml
Listening Endpoints Summary...

(DESCRIPTION=(ADDRESS=(PROTOCOL=tcp)(HOST=ora_02.cie.netapp.com)(PORT=1521)))
  (DESCRIPTION=(ADDRESS=(PROTOCOL=ipc)(KEY=EXTPROC1521)))

(DESCRIPTION=(ADDRESS=(PROTOCOL=tcps)(HOST=ora_02.cie.netapp.com)(PORT=5500))(Security=(my_wallet_directory=/u01/app/oracle/product/19.0.0/NTAP2/admin/NTAP2/xdb_wallet))(Presentation=HTTP)(Session=RAW))
Services Summary...
Service "192551f1d7e65fc3e06308b43d0a63ae.solutions.netapp.com" has
1 instance(s).
  Instance "NTAP2", status READY, has 1 handler(s) for this
service...
Service "1925529a43396002e06308b43d0a2d5a.solutions.netapp.com" has
1 instance(s).
  Instance "NTAP2", status READY, has 1 handler(s) for this
service...
Service "1925530776b76049e06308b43d0a49c3.solutions.netapp.com" has
1 instance(s).
  Instance "NTAP2", status READY, has 1 handler(s) for this
service...
Service "NTAP2.solutions.netapp.com" has 1 instance(s).
  Instance "NTAP2", status READY, has 1 handler(s) for this
service...
Service "NTAP2XDB.solutions.netapp.com" has 1 instance(s).
  Instance "NTAP2", status READY, has 1 handler(s) for this
service...
Service "ntap2_pdb1.solutions.netapp.com" has 1 instance(s).
  Instance "NTAP2", status READY, has 1 handler(s) for this
service...
Service "ntap2_pdb2.solutions.netapp.com" has 1 instance(s).
  Instance "NTAP2", status READY, has 1 handler(s) for this
service...
Service "ntap2_pdb3.solutions.netapp.com" has 1 instance(s).
  Instance "NTAP2", status READY, has 1 handler(s) for this
service...
The command completed successfully
[oracle@ora_02 ~]$

```

3. Validate Oracle database and dNFS

```

[oracle@ora-01 ~]$ cat /etc/oratab
#

```

```

# This file is used by ORACLE utilities.  It is created by root.sh
# and updated by either Database Configuration Assistant while
creating
# a database or ASM Configuration Assistant while creating ASM
instance.

# A colon, ':', is used as the field terminator.  A new line
terminates
# the entry.  Lines beginning with a pound sign, '#', are comments.
#
# Entries are of the form:
#   $ORACLE_SID:$ORACLE_HOME:<N|Y>:
#
# The first and second fields are the system identifier and home
# directory of the database respectively.  The third field indicates
# to the dbstart utility that the database should , "Y", or should
not,
# "N", be brought up at system boot time.
#
# Multiple entries with the same $ORACLE_SID are not allowed.
#
#
NTAP1:/u01/app/oracle/product/19.0.0/NTAP1:Y

```

```
[oracle@ora-01 ~]$ sqlplus / as sysdba
```

```
SQL*Plus: Release 19.0.0.0.0 - Production on Thu Feb 1 16:37:51 2024
Version 19.18.0.0.0
```

```
Copyright (c) 1982, 2022, Oracle. All rights reserved.
```

```
Connected to:
```

```
Oracle Database 19c Enterprise Edition Release 19.0.0.0.0 -
Production
Version 19.18.0.0.0
```

```
SQL> select name, open_mode, log_mode from v$database;
```

NAME	OPEN_MODE	LOG_MODE
NTAP1	READ WRITE	ARCHIVELOG

```
SQL> show pdbs
```

CON_ID	CON_NAME	OPEN MODE	RESTRICTED
--------	----------	-----------	------------

```

2 PDB$SEED                READ ONLY NO
3 NTAP1_PDB1              READ WRITE NO
4 NTAP1_PDB2              READ WRITE NO
5 NTAP1_PDB3              READ WRITE NO

```

```
SQL> select name from v$datafile;
```

```
NAME
```

```

-----
/u02/oradata/NTAP1/system01.dbf
/u02/oradata/NTAP1/sysaux01.dbf
/u02/oradata/NTAP1/undotbs01.dbf
/u02/oradata/NTAP1/pdbseed/system01.dbf
/u02/oradata/NTAP1/pdbseed/sysaux01.dbf
/u02/oradata/NTAP1/users01.dbf
/u02/oradata/NTAP1/pdbseed/undotbs01.dbf
/u02/oradata/NTAP1/NTAP1_pdb1/system01.dbf
/u02/oradata/NTAP1/NTAP1_pdb1/sysaux01.dbf
/u02/oradata/NTAP1/NTAP1_pdb1/undotbs01.dbf
/u02/oradata/NTAP1/NTAP1_pdb1/users01.dbf

```

```
NAME
```

```

-----
/u02/oradata/NTAP1/NTAP1_pdb2/system01.dbf
/u02/oradata/NTAP1/NTAP1_pdb2/sysaux01.dbf
/u02/oradata/NTAP1/NTAP1_pdb2/undotbs01.dbf
/u02/oradata/NTAP1/NTAP1_pdb2/users01.dbf
/u02/oradata/NTAP1/NTAP1_pdb3/system01.dbf
/u02/oradata/NTAP1/NTAP1_pdb3/sysaux01.dbf
/u02/oradata/NTAP1/NTAP1_pdb3/undotbs01.dbf
/u02/oradata/NTAP1/NTAP1_pdb3/users01.dbf

```

```
19 rows selected.
```

```
SQL> select name from v$controlfile;
```

```
NAME
```

```

-----
/u02/oradata/NTAP1/control01.ctl
/u03/orareco/NTAP1/control02.ctl

```

```
SQL> select member from v$logfile;
```

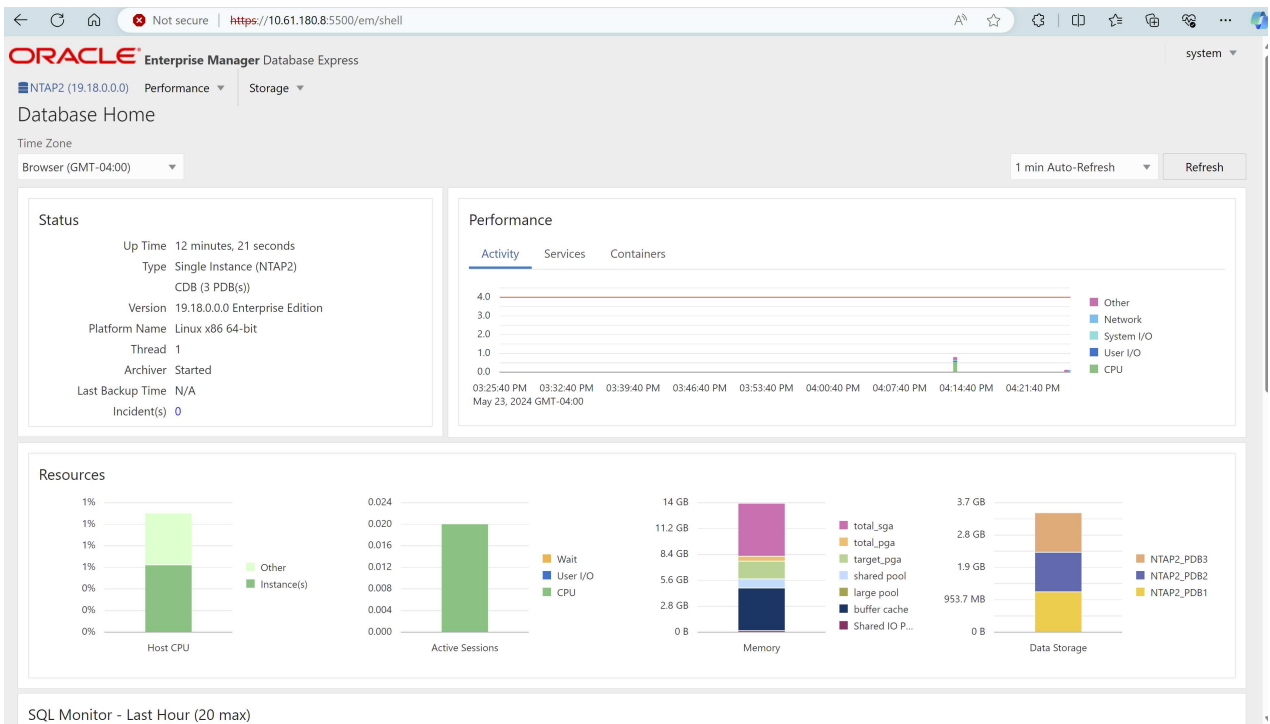
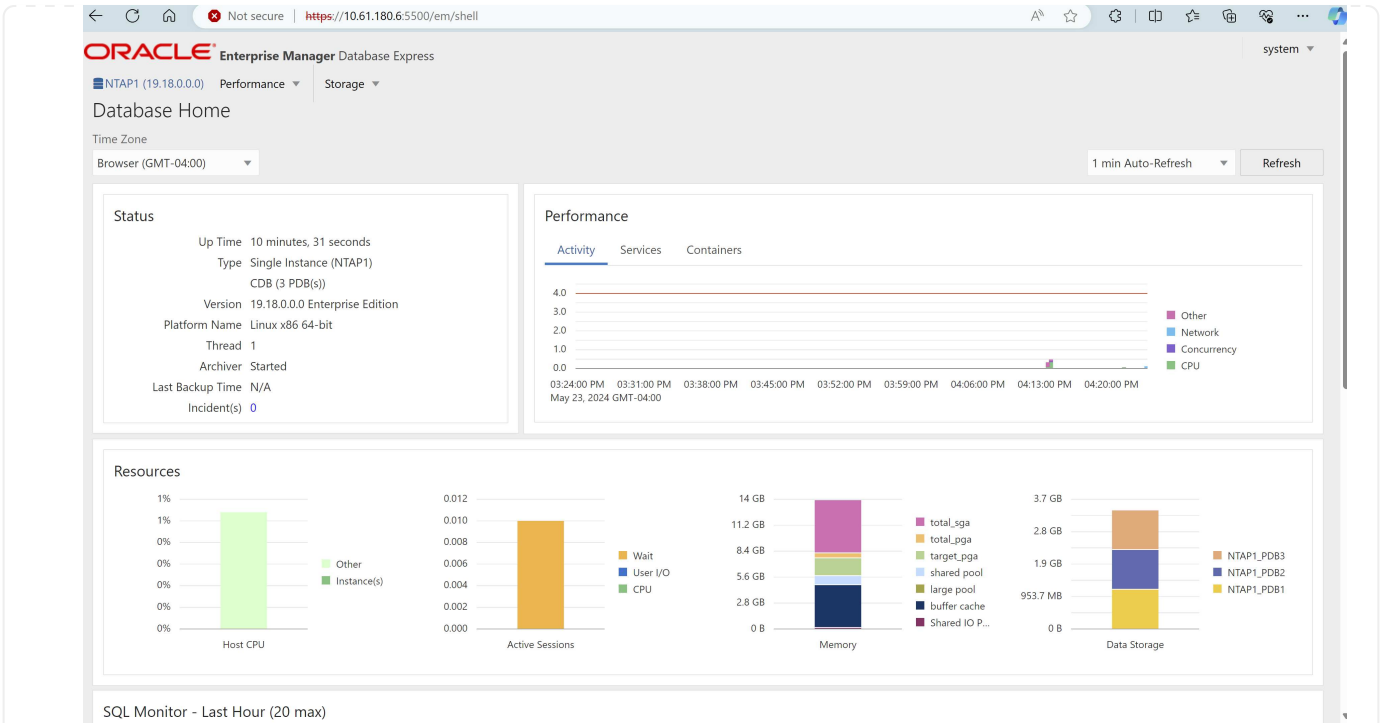
Oracle backup, restore, and clone with SnapCenter

NetApp recommends SnapCenter UI tool to manage Oracle database deployed in C-Series. Refer to TR-4979 [Simplified, Self-managed Oracle in VMware Cloud on AWS with guest-mounted FSx ONTAP](#) section Oracle backup, restore, and clone with SnapCenter for details on setting up SnapCenter and executing the database backup, restore, and clone workflows.

Where to find additional information

To learn more about the information described in this document, review the following documents and/or websites:

- NetApp AFF C-Series

<https://www.netapp.com/pdf.html?item=/media/81583-da-4240-aff-c-series.pdf>

- NetApp Enterprise Database Solutions

<https://docs.netapp.com/us-en/netapp-solutions/databases/index.html>

- Deploying Oracle Direct NFS

<https://docs.oracle.com/en/database/oracle/oracle-database/19/ladbi/deploying-dnfs.html#GUID-D06079DB-8C71-4F68-A1E3-A75D7D96DCE2>

TR-4983: Simplified, Automated Oracle Deployment on NetApp ASA with iSCSI

Allen Cao, Niyaz Mohamed, NetApp

This solution provides overview and details for automated Oracle deployment and protection in NetApp ASA array as primary database storage with iSCSI protocol and Oracle database configured in standalone ReStart using asm as volume manager.

Purpose

NetApp ASA systems deliver modern solutions to your SAN infrastructure. They simplify at scale and enable you to accelerate your business-critical applications such as databases, make sure that your data is always available (99.9999% uptime), and reduce TCO and carbon footprint. The NetApp ASA systems include A-Series models designed for the most performance-demanding applications and C-Series models optimized for cost-effective, large-capacity deployments. Together, the ASA A-Series and C-Series systems deliver exceptional performance to improve customer experience and reduce time to results, keep business-critical data available, protected, and secure, and provide more effective capacity for any workload, backed by the industry's most effective guarantee.

This documentation demonstrates the simplified deployment of Oracle databases in a SAN environment built with ASA systems using Ansible automation. The Oracle database is deployed in a standalone ReStart configuration with iSCSI protocol for data access and Oracle ASM for database disks management on the ASA storage array. It also provides information on Oracle database backup, restore, and clone using the NetApp SnapCenter UI tool for storage-efficient database operation in NetApp ASA systems.

This solution addresses the following use cases:

- Automated Oracle database deployment in NetApp ASA systems as primary database storage
- Oracle database backup and restore in NetApp ASA systems using NetApp SnapCenter tool
- Oracle database clone for dev/test or other use cases in NetApp ASA systems using NetApp SnapCenter tool

Audience

This solution is intended for the following people:

- A DBA who would like to deploy Oracle in NetApp ASA systems.
- A database solution architect who would like to test Oracle workloads in NetApp ASA systems.
- A storage administrator who would like to deploy and manage an Oracle database on NetApp ASA systems.
- An application owner who would like to stand up an Oracle database in NetApp ASA systems.

Solution test and validation environment

The testing and validation of this solution were performed in a lab setting that might not match the final deployment environment. See the section [Key factors for deployment consideration](#) for more information.

Architecture

Simplified, Automated Oracle Database Deployment on NetApp ASA with iSCSI

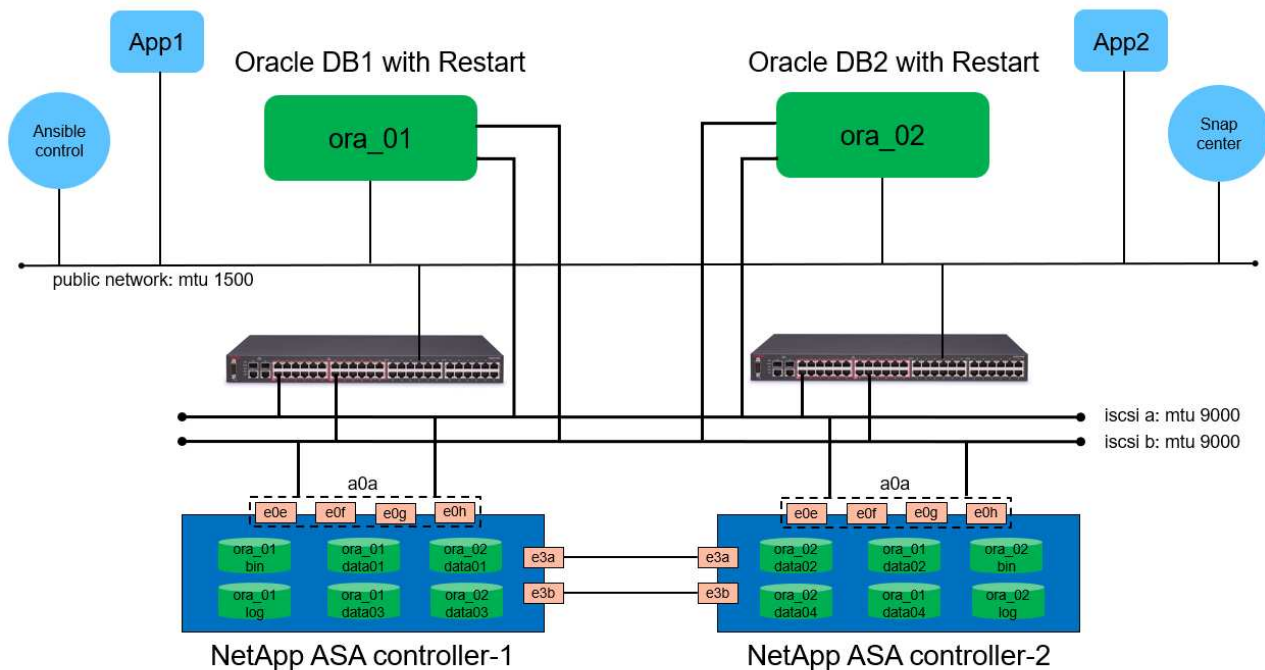

NetApp

Hardware and software components

Hardware

NetApp ASA A400	Version 9.13.1P1	2 NS224 shelves, 48 NVMe AFF drives with total 69.3 TiB capacity
UCSB-B200-M4	Intel® Xeon® CPU E5-2690 v4 @ 2.60GHz	4-node VMware ESXi cluster

Software

RedHat Linux	RHEL-8.6, 4.18.0-372.9.1.el8.x86_64 kernel	Deployed RedHat subscription for testing
Windows Server	2022 Standard, 10.0.20348 Build 20348	Hosting SnapCenter server
Oracle Grid Infrastructure	Version 19.18	Applied RU patch p34762026_190000_Linux-x86-64.zip
Oracle Database	Version 19.18	Applied RU patch p34765931_190000_Linux-x86-64.zip
Oracle OPatch	Version 12.2.0.1.36	Latest patch p6880880_190000_Linux-x86-64.zip
SnapCenter Server	Version 4.9P1	Workgroup deployment
VMware vSphere Hypervisor	version 6.5.0.20000	VMware Tools, Version: 11365 - Linux, 12352 - Windows
Open JDK	Version java-1.8.0-openjdk.x86_64	SnapCenter plugin requirement on DB VMs

Oracle database configuration in the lab environment

Server	Database	DB Storage
ora_01	NTAP1(NTAP1_PDB1,NTAP1_PDB2,NTAP1_PDB3)	iSCSI luns on ASA A400
ora_02	NTAP2(NTAP2_PDB1,NTAP2_PDB2,NTAP2_PDB3)	iSCSI luns on ASA A400

Key factors for deployment consideration

- Oracle database storage layout.** In this automated Oracle deployment, we provision four database volumes to host Oracle binary, data, and logs by default. We then create two ASM disk groups from data and logs luns. Within the +DATA asm disk group, we provision two data luns in a volume on each ASA A400 cluster node. Within the +LOGS asm disk group, we create two luns in a log volume on a single ASA A400 node. Multiple luns laid out within an ONTAP volume provides better performance in general.
- Multiple DB servers deployment.** The automation solution can deploy an Oracle container database to multiple DB servers in a single Ansible playbook run. Regardless of the number of DB servers, the playbook execution remains the same. In the event of multi-DB server deployments, the playbook builds with an algorithm to place database luns on dual controllers of ASA A400 optimally. The binary and logs luns of odd number DB server in server hosts index place on controller 1. The binary and logs luns of even number DB server in the server hosts index place on controller 2. The DB data luns evenly distributed to two controllers. Oracle ASM combines the data luns on two controllers into a single ASM disk group to fully utilize the processing power of both controllers.
- iSCSI configuration.** The database VMs connect to ASA storage with the iSCSI protocol for storage access. You should configure dual paths on each controller node for redundancy and set up iSCSI multi-path on the DB server for multi-path storage access. Enable jumbo frame on storage network to maximize performance and throughput.

- **Oracle ASM redundancy level to use for each Oracle ASM disk group that you create.** Because the ASA A400 configures storage in RAID DP for data protection at the cluster disk level, you should use `External Redundancy`, which means that the option does not allow Oracle ASM to mirror the contents of the disk group.
- **Database backup.** NetApp provides a SnapCenter software suite for database backup, restore, and cloning with a user-friendly UI interface. NetApp recommends implementing such a management tool to achieve fast (under a minute) SnapShot backup, quick (minutes) database restore, and database clone.

Solution deployment

The following sections provide step-by-step procedures for automated Oracle 19c deployment and protection in NetApp ASA A400 with directly mounted database luns via iSCSI to DB VM in a single node Restart configuration with Oracle ASM as database volume manager.

Prerequisites for deployment

Deployment requires the following prerequisites.

1. It is assumed that the NetApp ASA storage array has been installed and configured. This includes iSCSI broadcast domain, LACP interface groups a0a on both controller nodes, iSCSI VLAN ports (a0a-<iscsi-a-vlan-id>, a0a-<iscsi-b-vlan-id>) on both controller nodes. The following link provides detailed step-by-step instructions if help is needed. [Detailed guide - ASA A400](#)
2. Provision a Linux VM as an Ansible controller node with the latest version of Ansible and Git installed. Refer to the following link for details: [Getting Started with NetApp solution automation](#) in section - Setup the Ansible Control Node for CLI deployments on RHEL / CentOS or Setup the Ansible Control Node for CLI deployments on Ubuntu / Debian.
3. Clone a copy of the NetApp Oracle deployment automation toolkit for iSCSI.

```
git clone https://bitbucket.ngage.netapp.com/scm/ns-  
bb/na_oracle_deploy_iscsi.git
```

4. Provision a Windows server to run the NetApp SnapCenter UI tool with the latest version. Refer to the following link for details: [Install the SnapCenter Server](#)
5. Build two RHEL Oracle DB servers either bare metal or virtualized VM. Create an admin user on DB servers with sudo without password privilege and enable SSH private/public key authentication between Ansible host and Oracle DB server hosts. Stage following Oracle 19c installation files on DB servers /tmp/archive directory.

```
installer_archives:  
- "LINUX.X64_193000_grid_home.zip"  
- "p34762026_190000_Linux-x86-64.zip"  
- "LINUX.X64_193000_db_home.zip"  
- "p34765931_190000_Linux-x86-64.zip"  
- "p6880880_190000_Linux-x86-64.zip"
```



Ensure that you have allocated at least 50G in Oracle VM root volume to have sufficient space to stage Oracle installation files.

6. Watch the following video:

[Simplified and automated Oracle deployment on NetApp ASA with iSCSI](#)

Automation parameter files

Ansible playbook executes database installation and configuration tasks with predefined parameters. For this Oracle automation solution, there are three user-defined parameter files that need user input before playbook execution.

- `hosts` - define targets that the automation playbook is running against.
- `vars/vars.yml` - the global variable file that defines variables that apply to all targets.
- `host_vars/host_name.yml` - the local variable file that defines variables that apply only to a local target. In our use case, these are the Oracle DB servers.

In addition to these user-defined variable files, there are several default variable files that contain default parameters that do not require change unless necessary. The following sections show how the user-defined variable files are configured.

Parameter files configuration

1. Ansible target hosts file configuration:

```
# Enter NetApp ASA controller management IP address
[ontap]
172.16.9.32

# Enter Oracle servers names to be deployed one by one, follow by
each Oracle server public IP address, and ssh private key of admin
user for the server.
[oracle]
ora_01 ansible_host=10.61.180.21 ansible_ssh_private_key_file
=ora_01.pem
ora_02 ansible_host=10.61.180.23 ansible_ssh_private_key_file
=ora_02.pem
```

2. Global vars/vars.yml file configuration

```
#####
#####
#####          Oracle 19c deployment global user
configurable variables          #####
#####          Consolidate all variables from ONTAP, linux
and oracle                      #####
#####
#####
#####          ONTAP env specific config variables
#####
#####
#####
#####
#####          ONTAP platform: on-prem, aws-fsx.
ontap_platform: on-prem

# Enter ONTAP cluster management user credentials
username: "xxxxxxxx"
password: "xxxxxxxx"

##### on-prem platform specific user defined variables #####

# Enter Oracle SVM iSCSI lif addresses. Each controller configures
```

```

with dual paths iscsi_a, iscsi_b for redundancy
ora_iscsi_lif_mgmt:
  - {name: '{{ svm_name }}_mgmt', address: 172.21.253.220, netmask:
255.255.255.0, vlan_name: ora_mgmt, vlan_id: 3509}

ora_iscsi_lifs_node1:
  - {name: '{{ svm_name }}_lif_1a', address: 172.21.234.221,
netmask: 255.255.255.0, vlan_name: ora_iscsi_a, vlan_id: 3490}
  - {name: '{{ svm_name }}_lif_1b', address: 172.21.235.221,
netmask: 255.255.255.0, vlan_name: ora_iscsi_b, vlan_id: 3491}
ora_iscsi_lifs_node2:
  - {name: '{{ svm_name }}_lif_2a', address: 172.21.234.223,
netmask: 255.255.255.0, vlan_name: ora_iscsi_a, vlan_id: 3490}
  - {name: '{{ svm_name }}_lif_2b', address: 172.21.235.223,
netmask: 255.255.255.0, vlan_name: ora_iscsi_b, vlan_id: 3491}

#####
#####
###           Linux env specific config variables
###
#####
#####

# Enter RHEL subscription to enable repo
redhat_sub_username: xxxxxxxx
redhat_sub_password: "xxxxxxx"

#####
#####
###           Oracle DB env specific config variables
###
#####
#####

# Enter Database domain name
db_domain: solutions.netapp.com

# Enter initial password for all required Oracle passwords. Change
them after installation.
initial_pwd_all: xxxxxxxx

```

3. Local DB server host_vars/host_name.yml configuration

```
# User configurable Oracle host specific parameters

# Enter container database SID. By default, a container DB is
created with 3 PDBs within the CDB
oracle_sid: NTAP1

# Enter database shared memory size or SGA. CDB is created with SGA
at 75% of memory_limit, MB. The grand total of SGA should not exceed
75% available RAM on node.
memory_limit: 8192
```

Playbook execution

There are a total of six playbooks in the automation toolkit. Each performs different task blocks and serves different purposes.

```
0-all_playbook.yml - execute playbooks from 1-4 in one playbook run.
1-ansible_requirements.yml - set up Ansible controller with required
libs and collections.
2-linux_config.yml - execute Linux kernel configuration on Oracle DB
servers.
3-ontap_config.yml - configure ONTAP svm/volumes/luns for Oracle
database and grant DB server access to luns.
4-oracle_config.yml - install and configure Oracle on DB servers for
grid infrastructure and create a container database.
5-destroy.yml - optional to undo the environment to dismantle all.
```

There are three options to run the playbooks with the following commands.

1. Execute all deployment playbooks in one combined run.

```
ansible-playbook -i hosts 0-all_playbook.yml -u admin -e
@vars/vars.yml
```

2. Execute playbooks one at a time with the number sequence from 1-4.

```
ansible-playbook -i hosts 1-ansible_requirements.yml -u admin -e
@vars/vars.yml
```

```
ansible-playbook -i hosts 2-linux_config.yml -u admin -e
@vars/vars.yml
```

```
ansible-playbook -i hosts 3-ontap_config.yml -u admin -e
@vars/vars.yml
```

```
ansible-playbook -i hosts 4-oracle_config.yml -u admin -e
@vars/vars.yml
```

3. Execute 0-all_playbook.yml with a tag.

```
ansible-playbook -i hosts 0-all_playbook.yml -u admin -e  
@vars/vars.yml -t ansible_requirements
```

```
ansible-playbook -i hosts 0-all_playbook.yml -u admin -e  
@vars/vars.yml -t linux_config
```

```
ansible-playbook -i hosts 0-all_playbook.yml -u admin -e  
@vars/vars.yml -t ontap_config
```

```
ansible-playbook -i hosts 0-all_playbook.yml -u admin -e  
@vars/vars.yml -t oracle_config
```

4. Undo the environment

```
ansible-playbook -i hosts 5-destroy.yml -u admin -e @vars/vars.yml
```

Post execution validation

After the playbook run, login to the Oracle DB server as oracle user to validate that Oracle grid infrastructure and database are created successfully. Following is an example of Oracle database validation on host ora_01.

1. Validate the grid infrastructure and resources created.

```
[oracle@ora_01 ~]$ df -h
Filesystem                Size      Used Avail Use% Mounted on
devtmpfs                  7.7G       40K   7.7G   1% /dev
tmpfs                     7.8G     1.1G   6.7G  15% /dev/shm
tmpfs                     7.8G     312M   7.5G   4% /run
tmpfs                     7.8G        0   7.8G   0% /sys/fs/cgroup
/dev/mapper/rhel-root      44G       38G   6.8G  85% /
/dev/sda1                 1014M     258M   757M  26% /boot
tmpfs                     1.6G       12K   1.6G   1% /run/user/42
tmpfs                     1.6G       4.0K   1.6G   1% /run/user/1000
/dev/mapper/ora_01_biny_01p1 40G      21G    20G  52% /u01
[oracle@ora_01 ~]$ asm
[oracle@ora_01 ~]$ crsctl stat res -t
-----
-----
Name                Target  State          Server          State
details
-----
-----
Local Resources
-----
-----
ora.DATA.dg
                ONLINE  ONLINE        ora_01          STABLE
ora.LISTENER.lsnr
                ONLINE  INTERMEDIATE  ora_01          Not All
Endpoints Re
gistered, STABLE
ora.LOGS.dg
                ONLINE  ONLINE        ora_01          STABLE
ora.asm
                ONLINE  ONLINE        ora_01
Started, STABLE
ora.ons
                OFFLINE OFFLINE        ora_01          STABLE
-----
-----
Cluster Resources
-----
```

```

-----
ora.cssd
  1          ONLINE  ONLINE      ora_01      STABLE
ora.diskmon
  1          OFFLINE OFFLINE
ora.driver.afd
  1          ONLINE  ONLINE      ora_01      STABLE
ora.evmd
  1          ONLINE  ONLINE      ora_01      STABLE
ora.ntap1.db
  1          ONLINE  ONLINE      ora_01
Open,HOME=/u01/app/o

racle/product/19.0.0

/NTAP1, STABLE
-----
-----
[oracle@ora_01 ~]$

```



Ignore the Not All Endpoints Registered in State details. This results from a conflict of manual and dynamic database registration with the listener and can be safely ignored.

2. Validate ASM filter driver is working as expected.

```

[oracle@ora_01 ~]$ asmcmd
ASMCMDB> lsdg
State      Type      Rebal  Sector  Logical_Sector  Block      AU
Total_MB  Free_MB  Req_mir_free_MB  Usable_file_MB  Offline_disks
Voting_files  Name
MOUNTED   EXTERN  N      512     512     4096    4194304
327680    318644          0      318644          0
N  DATA/
MOUNTED   EXTERN  N      512     512     4096    4194304
81920     78880          0      78880          0
N  LOGS/
ASMCMDB> lsdsk
Path
AFD:ORA_01_DAT1_01
AFD:ORA_01_DAT1_03
AFD:ORA_01_DAT1_05
AFD:ORA_01_DAT1_07
AFD:ORA_01_DAT2_02
AFD:ORA_01_DAT2_04
AFD:ORA_01_DAT2_06
AFD:ORA_01_DAT2_08
AFD:ORA_01_LOGS_01
AFD:ORA_01_LOGS_02
ASMCMDB> afd_state
ASMCMDB-9526: The AFD state is 'LOADED' and filtering is 'ENABLED' on
host 'ora_01'
ASMCMDB>

```

3. Login to Oracle Enterprise Manager Express to validate database.

← → ↻ Not secure | https://10.61.180.21:5500/em/login



ORACLE ENTERPRISE MANAGER DATABASE EXPRESS



Copyright 2013, 2020, Oracle and/or its affiliates. All rights reserved.

← → ↻ Not secure | https://10.61.180.21:5500/em/shell

ORACLE Enterprise Manager Database Express system ▾

NTAP1 (19.18.0.0.0) Performance ▾ Storage ▾

Database Home

Time Zone: Browser (GMT-05:00) ▾ 1 min Auto-Refresh ▾ Refresh

Status

Up Time 1 hours, 7 minutes, 23 seconds
 Type Single Instance (NTAP1)
 CDB (3 PDB(s))
 Version 19.18.0.0.0 Enterprise Edition
 Platform Name Linux x86_64-bit
 Thread 1
 Archiver Stopped
 Last Backup Time N/A
 Incident(s) ❗ 4

Performance

Activity Services Containers

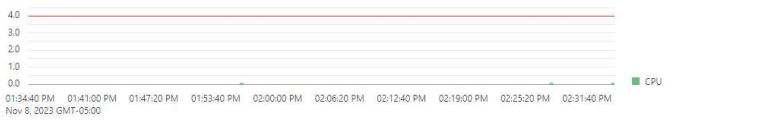

Resources

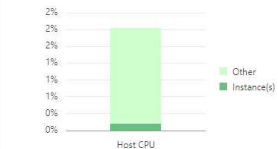

Host CPU



Active Sessions

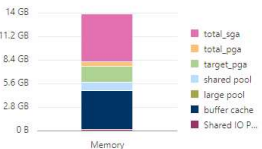

Memory

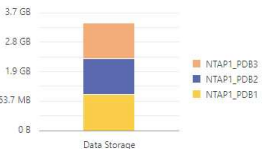

Data Storage

SQL Monitor - Last Hour (20 max)

Top 20 by Last Active Time Filter by Status, SQL ID or User Name

Enable additional port from sqlplus for login to individual container database or PDBs.

```
SQL> show pdbs
```

CON_ID	CON_NAME	OPEN MODE	RESTRICTED
2	PDB\$SEED	READ ONLY	NO
3	NTAP1_PDB1	READ WRITE	NO
4	NTAP1_PDB2	READ WRITE	NO
5	NTAP1_PDB3	READ WRITE	NO

```
SQL> alter session set container=NTAP1_PDB1;
```

Session altered.

```
SQL> select dbms_xdb_config.gethttpsport() from dual;
```

```
DBMS_XDB_CONFIG.GETHTTPSPO...
-----
                                0
```

```
SQL> exec DBMS_XDB_CONFIG.SETHTTPSPO...;
```

PL/SQL procedure successfully completed.

```
SQL> select dbms_xdb_config.gethttpsport() from dual;
```

```
DBMS_XDB_CONFIG.GETHTTPSPO...
-----
                                5501
```

login to NTAP1_PDB1 from port 5501.

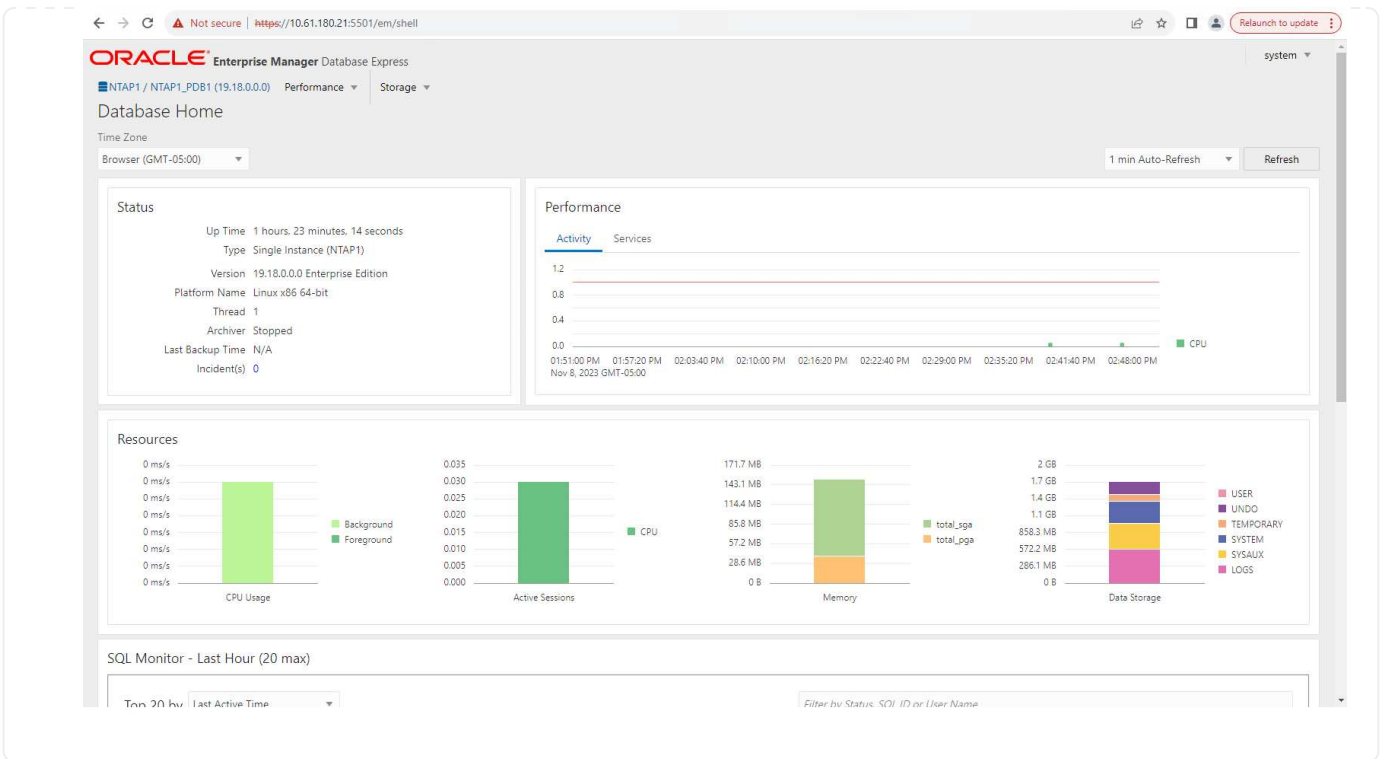

Oracle backup, restore, and clone with SnapCenter

Refer to TR-4979 [Simplified, self-managed Oracle in VMware Cloud on AWS with guest-mounted FSx ONTAP](#) section Oracle backup, restore, and clone with SnapCenter for details on setting up SnapCenter and executing the database backup, restore, and clone workflows.

Where to find additional information

To learn more about the information described in this document, review the following documents and/or websites:

- NETAPP ASA: ALL-FLASH SAN ARRAY

<https://www.netapp.com/data-storage/all-flash-san-storage-array/>

- Installing Oracle Grid Infrastructure for a Standalone Server with a New Database Installation

<https://docs.oracle.com/en/database/oracle/oracle-database/19/ladbi/installing-oracle-grid-infrastructure-for-a-standalone-server-with-a-new-database-installation.html#GUID-0B1CEE8C-C893-46AA-8A6A-7B5FAAEC72B3>

- Installing and Configuring Oracle Database Using Response Files

<https://docs.oracle.com/en/database/oracle/oracle-database/19/ladbi/installing-and-configuring-oracle-database-using-response-files.html#GUID-D53355E9-E901-4224-9A2A-B882070EDDF7>

- Use Red Hat Enterprise Linux 8.2 with ONTAP

https://docs.netapp.com/us-en/ontap-sanhost/hu_rhel_82.html#all-san-array-configurations

NVA-1155: Oracle 19c RAC databases on FlexPod Datacenter with Cisco UCS and NetApp AFF A800 over FC - Design and deployment guide

Allen Cao, NetApp

This design and deployment guide for Oracle 19c RAC databases on FlexPod Datacenter with Cisco UCS and NetApp AFF A800 over FC provides details of the solution design as well as step-by-step deployment processes for hosting Oracle RAC databases on most recent FlexPod Datacenter infrastructure with the Oracle Linux 8.2 operating system and a Red Hat compatible kernel.

[NVA-1155: Oracle 19c RAC databases on FlexPod Datacenter with Cisco UCS and NetApp AFF A800 over FC](#)

TR-4250: SAP with Oracle on UNIX and NFS with NetApp Clustered Data ONTAP and SnapManager for SAP 3.4

Nils Bauer, NetApp

TR-4250 addresses the challenges of designing storage solutions to support SAP business suite products using an Oracle database. The primary focus of this document is the common storage infrastructure design, deployment, operation, and management challenges faced by business and IT leaders who use the latest generation of SAP solutions. The recommendations in this document are generic; they are not specific to an SAP application or to the size and scope of the SAP implementation. TR-4250 assumes that the reader has a basic understanding of the technology and operation of NetApp and SAP products. TR-4250 was developed based on the interaction of technical staff from NetApp, SAP, Oracle, and our customers.

[TR-4250: SAP with Oracle on UNIX and NFS with NetApp Clustered Data ONTAP and SnapManager for SAP 3.4](#)

Deploying Oracle Database

Solution Overview

This page describes the Automated method for deploying Oracle19c on NetApp ONTAP storage.

Automated Deployment of Oracle19c for ONTAP on NFS

Organizations are automating their environments to gain efficiencies, accelerate deployments, and reduce manual effort. Configuration management tools like Ansible are being used to streamline enterprise database operations. In this solution, we demonstrate how you can use Ansible to automate the provisioning and configuration of Oracle 19c with NetApp ONTAP. By enabling storage administrators, systems administrators, and DBAs to consistently and rapidly deploy new storage, configure database servers, and install Oracle 19c software, you achieve the following benefits:

- Eliminate design complexities and human errors, and implement a repeatable consistent deployment and best practices
- Decrease time for provisioning of storage, configuration of DB hosts, and Oracle installation
- Increase database administrators, systems and storage administrators productivity
- Enable scaling of storage and databases with ease

NetApp provides customers with validated Ansible modules and roles to accelerate deployment, configuration, and lifecycle management of your Oracle database environment. This solution provides instruction and Ansible playbook code, to help you:

- Create and configure ONTAP NFS storage for Oracle Database
- Install Oracle 19c on RedHat Enterprise Linux 7/8 or Oracle Linux 7/8
- Configure Oracle 19c on ONTAP NFS storage

For more details or to begin, please see the overview videos below.

AWX/Tower Deployments

Part 1: Getting Started, Requirements, Automation Details and Initial AWX/Tower Configuration

[AWX Deployment](#)

Part 2: Variables and Running the Playbook

[AWX Playbook Run](#)

CLI Deployment

Part 1: Getting Started, Requirements, Automation Details and Ansible Control Host Setup

[CLI Deployment](#)

Part 2: Variables and Running the Playbook

[CLI Playbook Run](#)

Getting started

This solution has been designed to be run in an AWX/Tower environment or by CLI on an Ansible control host.

AWX/Tower

For AWX/Tower environments, you are guided through creating an inventory of your ONTAP cluster management and Oracle server (IPs and hostnames), creating credentials, configuring a project that pulls the Ansible code from NetApp Automation Github, and the Job Template that launches the automation.

1. Fill out the variables specific to your environment, and copy and paste them into the Extra Vars fields in your job template.
2. After the extra vars have been added to your job template, you can launch the automation.
3. The job template is run in three phases by specifying tags for `ontap_config`, `linux_config`, and `oracle_config`.

CLI via the Ansible control host

1. To configure the Linux host so that it can be used as an Ansible control host [click here for detailed instructions](#)
2. After the Ansible control host is configured, you can git clone the Ansible Automation repository.
3. Edit the hosts file with the IPs and/or hostnames of your ONTAP cluster management and Oracle server's management IPs.
4. Fill out the variables specific to your environment, and copy and paste them into the `vars.yml` file.
5. Each Oracle host has a variable file identified by its hostname that contains host-specific variables.
6. After all variable files have been completed, you can run the playbook in three phases by specifying tags for `ontap_config`, `linux_config`, and `oracle_config`.

Requirements

Environment	Requirements
Ansible environment	AWX/Tower or Linux host to be the Ansible control host
	Ansible v.2.10 and higher
	Python 3
	Python libraries - netapp-lib - xmltodict - jmespath
ONTAP	ONTAP version 9.3 - 9.7
	Two data aggregates
	NFS vlan and ifgrp created
Oracle server(s)	RHEL 7/8
	Oracle Linux 7/8
	Network interfaces for NFS, public, and optional mgmt
	Oracle installation files on Oracle servers

Automation Details

This automated deployment is designed with a single Ansible playbook that consists of three separate roles. The roles are for ONTAP, Linux, and Oracle configurations. The following table describes which tasks are being automated.

Role	Tasks
ontap_config	Pre-check of the ONTAP environment
	Creation of NFS based SVM for Oracle
	Creation of export policy
	Creation of volumes for Oracle
	Creation of NFS LIFs

Role	Tasks
linux_config	Create mount points and mount NFS volumes
	Verify NFS mounts
	OS specific configuration
	Create Oracle directories
	Configure hugepages
	Disable SELinux and firewall daemon
	Enable and start chronyd service
	increase file descriptor hard limit
	Create pam.d session file
oracle_config	Oracle software installation
	Create Oracle listener
	Create Oracle databases
	Oracle environment configuration
	Save PDB state
	Enable instance archive mode
	Enable DNFS client
	Enable database auto startup and shutdown between OS reboots

Default parameters

To simplify automation, we have preset many required Oracle deployment parameters with default values. It is generally not necessary to change the default parameters for most deployments. A more advanced user can make changes to the default parameters with caution. The default parameters are located in each role folder under defaults directory.

Deployment instructions

Before starting, download the following Oracle installation and patch files and place them in the `/tmp/archive` directory with read, write, and execute access for all users on each DB server to be deployed. The automation tasks look for the named installation files in that particular directory for Oracle installation and configuration.

```
LINUX.X64_193000_db_home.zip -- 19.3 base installer
p31281355_190000_Linux-x86-64.zip -- 19.8 RU patch
p6880880_190000_Linux-x86-64.zip -- opatch version 12.2.0.1.23
```

License

You should read license information as stated in the Github repository. By accessing, downloading, installing, or using the content in this repository, you agree the terms of the license laid out [here](#).

Note that there are certain restrictions around producing and/or sharing any derivative works with the content in this repository. Please make sure you read the terms of the [License](#) before using the content. If you do not agree to all of the terms, do not access, download, or use the content in this repository.

After you are ready, click [here for detailed AWX/Tower deployment procedures](#) or [here for CLI deployment](#).

Step-by-step deployment procedure

This page describes the Automated method for deploying Oracle19c on NetApp ONTAP storage.

AWX/Tower deployment Oracle 19c Database

1. Create the inventory, group, hosts, and credentials for your environment

This section describes the setup of inventory, groups, hosts, and access credentials in AWX/Ansible Tower that prepare the environment for consuming NetApp automated solutions.

1. Configure the inventory.
 - a. Navigate to Resources → Inventories → Add, and click Add Inventory.
 - b. Provide the name and organization details, and click Save.
 - c. On the Inventories page, click the inventory created.
 - d. If there are any inventory variables, paste them in the variables field.
 - e. Navigate to the Groups sub-menu and click Add.
 - f. Provide the name of the group for ONTAP, paste the group variables (if any) and click Save.
 - g. Repeat the process for another group for Oracle.
 - h. Select the ONTAP group created, go to the Hosts sub-menu and click Add New Host.
 - i. Provide the IP address of the ONTAP cluster management IP, paste the host variables (if any), and click Save.
 - j. This process must be repeated for the Oracle group and Oracle host(s) management IP/hostname.
2. Create credential types. For solutions involving ONTAP, you must configure the credential type to match username and password entries.
 - a. Navigate to Administration → Credential Types, and click Add.
 - b. Provide the name and description.
 - c. Paste the following content in Input Configuration:

```
fields:
  - id: username
    type: string
    label: Username
  - id: password
    type: string
    label: Password
    secret: true
  - id: vsadmin_password
    type: string
    label: vsadmin_password
    secret: true
```

a. Paste the following content into Injector Configuration:

```
extra_vars:
  password: '{{ password }}'
  username: '{{ username }}'
  vsadmin_password: '{{ vsadmin_password }}'
```

1. Configure the credentials.

- a. Navigate to Resources → Credentials, and click Add.
- b. Enter the name and organization details for ONTAP.
- c. Select the custom Credential Type you created for ONTAP.
- d. Under Type Details, enter the username, password, and vsadmin_password.
- e. Click Back to Credential and click Add.
- f. Enter the name and organization details for Oracle.
- g. Select the Machine credential type.
- h. Under Type Details, enter the Username and Password for the Oracle hosts.
- i. Select the correct Privilege Escalation Method, and enter the username and password.

2. Create a project

1. Go to Resources → Projects, and click Add.
 - a. Enter the name and organization details.
 - b. Select Git in the Source Control Credential Type field.
 - c. enter https://github.com/NetApp-Automation/na_oracle19c_deploy.git as the source control URL.
 - d. Click Save.
 - e. The project might need to sync occasionally when the source code changes.

3. Configure Oracle host_vars

The variables defined in this section are applied to each individual Oracle server and database.

1. Input your environment-specific parameters in the following embedded Oracle hosts variables or host_vars form.



The items in blue must be changed to match your environment.

Host VARS Config

```
#####
##### Host Variables Configuration #####
#####

# Add your Oracle Host
ansible_host: "10.61.180.15"

# Oracle db log archive mode: true - ARCHIVELOG or false - NOARCHIVELOG
log_archive_mode: "true"

# Number of pluggable databases per container instance identified by sid.
Pdb_name specifies the prefix for container database naming in this case
cdb2_pdb1, cdb2_pdb2, cdb2_pdb3
oracle_sid: "cdb2"
pdb_num: "3"
pdb_name: "{{ oracle_sid }}_pdb"

# CDB listener port, use different listener port for additional CDB on
same host
listener_port: "1523"

# CDB is created with SGA at 75% of memory_limit, MB. Consider how many
databases to be hosted on the node and how much ram to be allocated to
each DB. The grand total SGA should not exceed 75% available RAM on node.
memory_limit: "5464"

# Set "em_configuration: DBEXPRESS" to install enterprise manager express
and choose a unique port from 5500 to 5599 for each sid on the host.
# Leave them black if em express is not installed.
em_configuration: "DBEXPRESS"
em_express_port: "5501"

# {{groups.oracle[0]}} represents first Oracle DB server as defined in
Oracle hosts group [oracle]. For concurrent multiple Oracle DB servers
deployment, [0] will be incremented for each additional DB server. For
example, {{groups.oracle[1]}}" represents DB server 2,
```

"{{groups.oracle[2]}}" represents DB server 3 ... As a good practice and the default, minimum three volumes is allocated to a DB server with corresponding /u01, /u02, /u03 mount points, which store oracle binary, oracle data, and oracle recovery files respectively. Additional volumes can be added by click on "More NFS volumes" but the number of volumes allocated to a DB server must match with what is defined in global vars file by volumes_nfs parameter, which dictates how many volumes are to be created for each DB server.

```
host_datastores_nfs:
  - {vol_name: "{{groups.oracle[0]}}_u01", aggr_name: "aggr01_node01",
    lif: "172.21.94.200", size: "25"}
  - {vol_name: "{{groups.oracle[0]}}_u02", aggr_name: "aggr01_node01",
    lif: "172.21.94.200", size: "25"}
  - {vol_name: "{{groups.oracle[0]}}_u03", aggr_name: "aggr01_node01",
    lif: "172.21.94.200", size: "25"}
```

- a. Fill in all variables in the blue fields.
- b. After completing variables input, click the Copy button on the form to copy all variables to be transferred to AWX or Tower.
- c. Navigate back to AWX or Tower and go to Resources → Hosts, and select and open the Oracle server configuration page.
- d. Under the Details tab, click edit and paste the copied variables from step 1 to the Variables field under the YAML tab.
- e. Click Save.
- f. Repeat this process for any additional Oracle servers in the system.

4. Configure global variables

Variables defined in this section apply to all Oracle hosts, databases, and the ONTAP cluster.

1. Input your environment-specific parameters in following embedded global variables or vars form.



The items in blue must be changed to match your environment.

```
#####
##### Oracle 19c deployment global user configuration variables #####
##### Consolidate all variables from ontap, linux and oracle #####
#####

#####
### Ontap env specific config variables ###
#####

#Inventory group name
#Default inventory group name - 'ontap'
```

```

#Change only if you are changing the group name either in inventory/hosts
file or in inventory groups in case of AWX/Tower
hosts_group: "ontap"

#CA_signed_certificates (ONLY CHANGE to 'true' IF YOU ARE USING CA SIGNED
CERTIFICATES)
ca_signed_certs: "false"

#Names of the Nodes in the ONTAP Cluster
nodes:
  - "AFF-01"
  - "AFF-02"

#Storage VLANs
#Add additional rows for vlans as necessary
storage_vlans:
  - {vlan_id: "203", name: "infra_NFS", protocol: "NFS"}
More Storage VLANsEnter Storage VLANs details

#Details of the Data Aggregates that need to be created
#If Aggregate creation takes longer, subsequent tasks of creating volumes
may fail.
#There should be enough disks already zeroed in the cluster, otherwise
aggregate create will zero the disks and will take long time
data_aggregates:
  - {aggr_name: "aggr01_node01"}
  - {aggr_name: "aggr01_node02"}

#SVM name
svm_name: "ora_svm"

# SVM Management LIF Details
svm_mgmt_details:
  - {address: "172.21.91.100", netmask: "255.255.255.0", home_port: "e0M"}

# NFS storage parameters when data_protocol set to NFS. Volume named after
Oracle hosts name identified by mount point as follow for oracle DB server
1. Each mount point dedicates to a particular Oracle files: u01 - Oracle
binary, u02 - Oracle data, u03 - Oracle redo. Add additional volumes by
click on "More NFS volumes" and also add the volumes list to corresponding
host_vars as host_datastores_nfs variable. For multiple DB server
deployment, additional volumes sets needs to be added for additional DB
server. Input variable "{{groups.oracle[1]}}_u01",
 "{{groups.oracle[1]}}_u02", and "{{groups.oracle[1]}}_u03" as vol_name for
second DB server. Place volumes for multiple DB servers alternatingly
between controllers for balanced IO performance, e.g. DB server 1 on

```

controller node1, DB server 2 on controller node2 etc. Make sure match lif address with controller node.

volumes_nfs:

```
- {vol_name: "{{groups.oracle[0]}}_u01", aggr_name: "aggr01_node01",  
lif: "172.21.94.200", size: "25"}  
- {vol_name: "{{groups.oracle[0]}}_u02", aggr_name: "aggr01_node01",  
lif: "172.21.94.200", size: "25"}  
- {vol_name: "{{groups.oracle[0]}}_u03", aggr_name: "aggr01_node01",  
lif: "172.21.94.200", size: "25"}
```

#NFS LIFs IP address and netmask

nfs_lifs_details:

```
- address: "172.21.94.200" #for node-1  
  netmask: "255.255.255.0"  
- address: "172.21.94.201" #for node-2  
  netmask: "255.255.255.0"
```

#NFS client match

client_match: "172.21.94.0/24"

```
#####  
### Linux env specific config variables ###  
#####
```

#NFS Mount points for Oracle DB volumes

mount_points:

```
- "/u01"  
- "/u02"  
- "/u03"
```

Up to 75% of node memory size divided by 2mb. Consider how many databases to be hosted on the node and how much ram to be allocated to each DB.

Leave it blank if hugepage is not configured on the host.

hugepages_nr: "1234"

RedHat subscription username and password

```
redhat_sub_username: "xxx"  
redhat_sub_password: "xxx"
```

```
#####
```



```

### DB env specific install and config variables ###
#####

db_domain: "your.domain.com"

# Set initial password for all required Oracle passwords. Change them
after installation.

initial_pwd_all: "netapp123"

```

1. Fill in all variables in blue fields.
2. After completing variables input, click the Copy button on the form to copy all variables to be transferred to AWX or Tower into the following job template.

5. Configure and launch the job template.

1. Create the job template.
 - a. Navigate to Resources → Templates → Add and click Add Job Template.
 - b. Enter the name and description
 - c. Select the Job type; Run configures the system based on a playbook, and Check performs a dry run of a playbook without actually configuring the system.
 - d. Select the corresponding inventory, project, playbook, and credentials for the playbook.
 - e. Select the all_playbook.yml as the default playbook to be executed.
 - f. Paste global variables copied from step 4 into the Template Variables field under the YAML tab.
 - g. Check the box Prompt on Launch in the Job Tags field.
 - h. Click Save.
2. Launch the job template.
 - a. Navigate to Resources → Templates.
 - b. Click the desired template and then click Launch.
 - c. When prompted on launch for Job Tags, type in requirements_config. You might need to click the Create Job Tag line below requirements_config to enter the job tag.



requirements_config ensures that you have the correct libraries to run the other roles.

- a. Click Next and then Launch to start the job.
- b. Click View → Jobs to monitor the job output and progress.
- c. When prompted on launch for Job Tags, type in ontap_config. You might need to click the Create "Job Tag" line right below ontap_config to enter the job tag.
- d. Click Next and then Launch to start the job.
- e. Click View → Jobs to monitor the job output and progress
- f. After the ontap_config role has completed, run the process again for linux_config.
- g. Navigate to Resources → Templates.

- h. Select the desired template and then click Launch.
- i. When prompted on launch for the Job Tags type in linux_config, you might need to select the Create "job tag" line right below linux_config to enter the job tag.
- j. Click Next and then Launch to start the job.
- k. Select View → Jobs to monitor the job output and progress.
- l. After the linux_config role has completed, run the process again for oracle_config.
- m. Go to Resources → Templates.
- n. Select the desired template and then click Launch.
- o. When prompted on launch for Job Tags, type oracle_config. You might need to select the Create "Job Tag" line right below oracle_config to enter the job tag.
- p. Click Next and then Launch to start the job.
- q. Select View → Jobs to monitor the job output and progress.

6. Deploy additional database on same Oracle host

The Oracle portion of the playbook creates a single Oracle container database on an Oracle server per execution. To create additional container databases on the same server, complete the following steps.

1. Revise host_vars variables.
 - a. Go back to step 2 - Configure Oracle host_vars.
 - b. Change the Oracle SID to a different naming string.
 - c. Change the listener port to different number.
 - d. Change the EM Express port to a different number if you are installing EM Express.
 - e. Copy and paste the revised host variables to the Oracle Host Variables field in the Host Configuration Detail tab.
2. Launch the deployment job template with only the oracle_config tag.
3. Log in to Oracle server as oracle user and execute the following commands:

```
ps -ef | grep ora
```



This will list oracle processes if installation completed as expected and oracle DB started

4. Log in to the database to check the db configuration settings and the PDBs created with the following command sets.

```

[oracle@localhost ~]$ sqlplus / as sysdba

SQL*Plus: Release 19.0.0.0.0 - Production on Thu May 6 12:52:51 2021
Version 19.8.0.0.0

Copyright (c) 1982, 2019, Oracle. All rights reserved.

Connected to:
Oracle Database 19c Enterprise Edition Release 19.0.0.0.0 - Production
Version 19.8.0.0.0

SQL>

SQL> select name, log_mode from v$database;
NAME          LOG_MODE
-----
CDB2          ARCHIVELOG

SQL> show pdbs

          CON_ID CON_NAME                                OPEN MODE  RESTRICTED
-----
          2 PDB$SEED                                READ ONLY  NO
          3 CDB2_PDB1                            READ WRITE NO
          4 CDB2_PDB2                            READ WRITE NO
          5 CDB2_PDB3                            READ WRITE NO

col svrname form a30
col dirname form a30
select svrname, dirname, nfsversion from v$dnfs_servers;

SQL> col svrname form a30
SQL> col dirname form a30
SQL> select svrname, dirname, nfsversion from v$dnfs_servers;

SVRNAME                                DIRNAME                                NFSVERSION
-----
172.21.126.200                        /rhelora03_u02                        NFSv3.0
172.21.126.200                        /rhelora03_u03                        NFSv3.0
172.21.126.200                        /rhelora03_u01                        NFSv3.0

```

This confirms that dNFS is working properly.

5. Connect to database via listener to check the Oracle listener configuration with the following command. Change to the appropriate listener port and database service name.

```
[oracle@localhost ~]$ sqlplus
system@//localhost:1523/cdb2_pdb1.cie.netapp.com

SQL*Plus: Release 19.0.0.0.0 - Production on Thu May 6 13:19:57 2021
Version 19.8.0.0.0

Copyright (c) 1982, 2019, Oracle. All rights reserved.

Enter password:
Last Successful login time: Wed May 05 2021 17:11:11 -04:00

Connected to:
Oracle Database 19c Enterprise Edition Release 19.0.0.0.0 - Production
Version 19.8.0.0.0

SQL> show user
USER is "SYSTEM"
SQL> show con_name
CON_NAME
CDB2_PDB1
```

This confirms that Oracle listener is working properly.

Where to go for help?

If you need help with the toolkit, please join the [NetApp Solution Automation community support slack channel](#) and look for the solution-automation channel to post your questions or inquires.

Step-by-step deployment procedure

This document details the deployment of Oracle 19c using the automation command line interface (cli).

CLI deployment Oracle 19c Database

This section covers the steps required to prepare and deploy Oracle19c Database with the CLI. Make sure that you have reviewed the [Getting Started and Requirements section](#) and prepared your environment accordingly.

Download Oracle19c repo

1. From your ansible controller, run the following command:

```
git clone https://github.com/NetApp-Automation/na_oracle19c_deploy.git
```

2. After downloading the repository, change directories to na_oracle19c_deploy <cd na_oracle19c_deploy>.

Edit the hosts file

Complete the following before deployment:

1. Edit your hosts file `na_oracle19c_deploy` directory.
2. Under `[ontap]`, change the IP address to your cluster management IP.
3. Under the `[oracle]` group, add the oracle hosts names. The host name must be resolved to its IP address either through DNS or the hosts file, or it must be specified in the host.
4. After you have completed these steps, save any changes.

The following example depicts a host file:

```
#ONTAP Host

[ontap]

"10.61.184.183"

#Oracle hosts

[oracle]

"rtpora01"

"rtpora02"
```

This example executes the playbook and deploys oracle 19c on two oracle DB servers concurrently. You can also test with just one DB server. In that case, you only need to configure one host variable file.



The playbook executes the same way regardless of how many Oracle hosts and databases you deploy.

Edit the `host_name.yml` file under `host_vars`

Each Oracle host has its host variable file identified by its host name that contains host-specific variables. You can specify any name for your host. Edit and copy the `host_vars` from the Host VARS Config section and paste it into your desired `host_name.yml` file.



The items in blue must be changed to match your environment.

Host VARS Config

```
#####
##### Host Variables Configuration #####
#####

# Add your Oracle Host
```

```

ansible_host: "10.61.180.15"

# Oracle db log archive mode: true - ARCHIVELOG or false - NOARCHIVELOG
log_archive_mode: "true"

# Number of pluggable databases per container instance identified by sid.
Pdb_name specifies the prefix for container database naming in this case
cdb2_pdb1, cdb2_pdb2, cdb2_pdb3
oracle_sid: "cdb2"
pdb_num: "3"
pdb_name: "{{ oracle_sid }}_pdb"

# CDB listener port, use different listener port for additional CDB on
same host
listener_port: "1523"

# CDB is created with SGA at 75% of memory_limit, MB. Consider how many
databases to be hosted on the node and how much ram to be allocated to
each DB. The grand total SGA should not exceed 75% available RAM on node.
memory_limit: "5464"

# Set "em_configuration: DBEXPRESS" to install enterprise manager express
and choose a unique port from 5500 to 5599 for each sid on the host.
# Leave them black if em express is not installed.
em_configuration: "DBEXPRESS"
em_express_port: "5501"

# {{groups.oracle[0]}} represents first Oracle DB server as defined in
Oracle hosts group [oracle]. For concurrent multiple Oracle DB servers
deployment, [0] will be incremented for each additional DB server. For
example, {{groups.oracle[1]}}" represents DB server 2,
"{{groups.oracle[2]}}" represents DB server 3 ... As a good practice and
the default, minimum three volumes is allocated to a DB server with
corresponding /u01, /u02, /u03 mount points, which store oracle binary,
oracle data, and oracle recovery files respectively. Additional volumes
can be added by click on "More NFS volumes" but the number of volumes
allocated to a DB server must match with what is defined in global vars
file by volumes_nfs parameter, which dictates how many volumes are to be
created for each DB server.
host_datastores_nfs:
  - {vol_name: "{{groups.oracle[0]}}_u01", aggr_name: "aggr01_node01",
lif: "172.21.94.200", size: "25"}
  - {vol_name: "{{groups.oracle[0]}}_u02", aggr_name: "aggr01_node01",
lif: "172.21.94.200", size: "25"}
  - {vol_name: "{{groups.oracle[0]}}_u03", aggr_name: "aggr01_node01",
lif: "172.21.94.200", size: "25"}

```

Edit the vars.yml file

The `vars.yml` file consolidates all environment-specific variables (ONTAP, Linux, or Oracle) for Oracle deployment.

1. Edit and copy the variables from the VARS section and paste these variables into your `vars.yml` file.

```
#####
##### Oracle 19c deployment global user configuration variables #####
##### Consolidate all variables from ontap, linux and oracle #####
#####

#####

### Ontap env specific config variables ###
#####

#Inventory group name
#Default inventory group name - 'ontap'
#Change only if you are changing the group name either in inventory/hosts
file or in inventory groups in case of AWX/Tower
hosts_group: "ontap"

#CA_signed_certificates (ONLY CHANGE to 'true' IF YOU ARE USING CA SIGNED
CERTIFICATES)
ca_signed_certs: "false"

#Names of the Nodes in the ONTAP Cluster
nodes:
  - "AFF-01"
  - "AFF-02"

#Storage VLANs
#Add additional rows for vlans as necessary
storage_vlans:
  - {vlan_id: "203", name: "infra_NFS", protocol: "NFS"}
More Storage VLANsEnter Storage VLANs details

#Details of the Data Aggregates that need to be created
#If Aggregate creation takes longer, subsequent tasks of creating volumes
may fail.
#There should be enough disks already zeroed in the cluster, otherwise
aggregate create will zero the disks and will take long time
data_aggregates:
  - {aggr_name: "aggr01_node01"}
  - {aggr_name: "aggr01_node02"}

#SVM name
```

```

svm_name: "ora_svm"

# SVM Management LIF Details
svm_mgmt_details:
  - {address: "172.21.91.100", netmask: "255.255.255.0", home_port: "e0M"}

# NFS storage parameters when data_protocol set to NFS. Volume named after
Oracle hosts name identified by mount point as follow for oracle DB server
1. Each mount point dedicates to a particular Oracle files: u01 - Oracle
binary, u02 - Oracle data, u03 - Oracle redo. Add additional volumes by
click on "More NFS volumes" and also add the volumes list to corresponding
host_vars as host_datastores_nfs variable. For multiple DB server
deployment, additional volumes sets needs to be added for additional DB
server. Input variable "{{groups.oracle[1]}}_u01",
 "{{groups.oracle[1]}}_u02", and "{{groups.oracle[1]}}_u03" as vol_name for
second DB server. Place volumes for multiple DB servers alternately
between controllers for balanced IO performance, e.g. DB server 1 on
controller node1, DB server 2 on controller node2 etc. Make sure match lif
address with controller node.

volumes_nfs:
  - {vol_name: "{{groups.oracle[0]}}_u01", aggr_name: "aggr01_node01",
lif: "172.21.94.200", size: "25"}
  - {vol_name: "{{groups.oracle[0]}}_u02", aggr_name: "aggr01_node01",
lif: "172.21.94.200", size: "25"}
  - {vol_name: "{{groups.oracle[0]}}_u03", aggr_name: "aggr01_node01",
lif: "172.21.94.200", size: "25"}

#NFS LIFs IP address and netmask

nfs_lifs_details:
  - address: "172.21.94.200" #for node-1
    netmask: "255.255.255.0"
  - address: "172.21.94.201" #for node-2
    netmask: "255.255.255.0"

#NFS client match

client_match: "172.21.94.0/24"

#####
### Linux env specific config variables ###
#####

#NFS Mount points for Oracle DB volumes

mount_points:

```



```

- "/u01"
- "/u02"
- "/u03"

# Up to 75% of node memory size divided by 2mb. Consider how many
databases to be hosted on the node and how much ram to be allocated to
each DB.
# Leave it blank if hugepage is not configured on the host.

hugepages_nr: "1234"

# RedHat subscription username and password

redhat_sub_username: "xxx"
redhat_sub_password: "xxx"

#####
### DB env specific install and config variables ###
#####

db_domain: "your.domain.com"

# Set initial password for all required Oracle passwords. Change them
after installation.

initial_pwd_all: "netappl23"

```

Run the playbook

After completing the required environment prerequisites and copying the variables into `vars.yml` and `your_host.yml`, you are now ready to deploy the playbooks.



<username> must be changed to match your environment.

1. Run the ONTAP playbook by passing the correct tags and ONTAP cluster username. Fill the password for ONTAP cluster, and vsadmin when prompted.

```

ansible-playbook -i hosts all_playbook.yml -u username -k -K -t
ontap_config -e @vars/vars.yml

```

2. Run the Linux playbook to execute Linux portion of deployment. Input for admin ssh password as well as sudo password.

```

ansible-playbook -i hosts all_playbook.yml -u username -k -K -t
linux_config -e @vars/vars.yml

```

3. Run the Oracle playbook to execute Oracle portion of deployment. Input for admin ssh password as well as sudo password.

```
ansible-playbook -i hosts all_playbook.yml -u username -k -K -t
oracle_config -e @vars/vars.yml
```

Deploy Additional Database on Same Oracle Host

The Oracle portion of the playbook creates a single Oracle container database on an Oracle server per execution. To create additional container database on the same server, complete the following steps:

1. Revise the `host_vars` variables.
 - a. Go back to step 3 - Edit the `host_name.yml` file under `host_vars`.
 - b. Change the Oracle SID to a different naming string.
 - c. Change the listener port to different number.
 - d. Change the EM Express port to a different number if you have installed EM Express.
 - e. Copy and paste the revised host variables to the Oracle host variable file under `host_vars`.
2. Execute the playbook with the `oracle_config` tag as shown above in [Run the playbook](#).

Validate Oracle installation

1. Log in to Oracle server as oracle user and execute the following commands:

```
ps -ef | grep ora
```



This will list oracle processes if installation completed as expected and oracle DB started

2. Log in to the database to check the db configuration settings and the PDBs created with the following command sets.

```

[oracle@localhost ~]$ sqlplus / as sysdba

SQL*Plus: Release 19.0.0.0.0 - Production on Thu May 6 12:52:51 2021
Version 19.8.0.0.0

Copyright (c) 1982, 2019, Oracle. All rights reserved.

Connected to:
Oracle Database 19c Enterprise Edition Release 19.0.0.0.0 - Production
Version 19.8.0.0.0

SQL>

SQL> select name, log_mode from v$database;
NAME          LOG_MODE
-----
CDB2          ARCHIVELOG

SQL> show pdbs

          CON_ID CON_NAME                                OPEN MODE  RESTRICTED
-----
          2 PDB$SEED                                READ ONLY  NO
          3 CDB2_PDB1                            READ WRITE NO
          4 CDB2_PDB2                            READ WRITE NO
          5 CDB2_PDB3                            READ WRITE NO

col svrname form a30
col dirname form a30
select svrname, dirname, nfsversion from v$dnfs_servers;

SQL> col svrname form a30
SQL> col dirname form a30
SQL> select svrname, dirname, nfsversion from v$dnfs_servers;

SVRNAME                                DIRNAME                                NFSVERSION
-----
172.21.126.200                          /rhelora03_u02                          NFSv3.0
172.21.126.200                          /rhelora03_u03                          NFSv3.0
172.21.126.200                          /rhelora03_u01                          NFSv3.0

```

This confirms that dNFS is working properly.

3. Connect to database via listener to check the Oracle listener configuration with the following command. Change to the appropriate listener port and database service name.

```
[oracle@localhost ~]$ sqlplus
system@//localhost:1523/cdb2_pdb1.cie.netapp.com

SQL*Plus: Release 19.0.0.0.0 - Production on Thu May 6 13:19:57 2021
Version 19.8.0.0.0

Copyright (c) 1982, 2019, Oracle. All rights reserved.

Enter password:
Last Successful login time: Wed May 05 2021 17:11:11 -04:00

Connected to:
Oracle Database 19c Enterprise Edition Release 19.0.0.0.0 - Production
Version 19.8.0.0.0

SQL> show user
USER is "SYSTEM"
SQL> show con_name
CON_NAME
CDB2_PDB1
```

This confirms that Oracle listener is working properly.

Where to go for help?

If you need help with the toolkit, please join the [NetApp Solution Automation community support slack channel](#) and look for the solution-automation channel to post your questions or inquires.

Solution Overview

This page describes the Automated method for deploying Oracle19c on NetApp ONTAP storage.

Automated Data Protection for Oracle Databases

Organizations are automating their environments to gain efficiencies, accelerate deployments, and reduce manual effort. Configuration management tools like Ansible are being used to streamline enterprise database operations. In this solution, we demonstrate how you can use Ansible to automate the data protection of Oracle with NetApp ONTAP. By enabling storage administrators, systems administrators, and DBAs to consistently and rapidly setup data replication to an offsite data center or to public cloud, you achieve the following benefits:

- Eliminate design complexities and human errors, and implement a repeatable consistent deployment and best practices
- Decrease time for configuration of Intercluster replication, CVO instantiation, and recovery of Oracle databases
- Increase database administrators, systems and storage administrators productivity

- Provides database recovery workflow for ease of testing a DR scenario.

NetApp provides customers with validated Ansible modules and roles to accelerate deployment, configuration, and lifecycle management of your Oracle database environment. This solution provides instruction and Ansible playbook code, to help you:

On Prem to on prem replication

- Create intercluster lifs on source and destination
- Establish cluster and vserver peering
- Create and initialize SnapMirror of Oracle volumes
- Create a replication schedule through AWX/Tower for Oracle binaries, databases, and logs
- Restore Oracle DB on the destination, and bring database online

On Prem to CVO in AWS

- Create AWS connector
- Create CVO instance in AWS
- Add On-Prem cluster to Cloud Manager
- Create intercluster lifs on source
- Establish cluster and vserver peering
- Create and initialize SnapMirror of Oracle volumes
- Create a replication schedule through AWX/Tower for Oracle binaries, databases, and logs
- Restore Oracle DB on the destination, and bring database online

After you are ready, click [here for getting started with the solution](#).

Getting started

This solution has been designed to be run in an AWX/Tower environment.

AWX/Tower

For AWX/Tower environments, you are guided through creating an inventory of your ONTAP cluster management and Oracle server (IPs and hostnames), creating credentials, configuring a project that pulls the Ansible code from NetApp Automation Github, and the Job Template that launches the automation.

1. The solution has been designed to run in a private cloud scenario (on-premise to on-premise), and hybrid cloud (on-premise to public cloud Cloud Volumes ONTAP [CVO])
2. Fill out the variables specific to your environment, and copy and paste them into the Extra Vars fields in your job template.
3. After the extra vars have been added to your job template, you can launch the automation.
4. The automation is set to be ran three phases (Setup, Replication Schedule for Oracle Binaries, Database, Logs, and Replication Schedule just for Logs), and a forth phase to recovering the database at a DR site.
5. For detailed instructions for obtaining the keys and tokens necessary for the CVO Data Protection visit [Gather Pre-requisites For CVO and Connector Deployments](#)

Requirements

On-Prem

Environment	Requirements
Ansible environment	AWX/Tower
	Ansible v.2.10 and higher
	Python 3
	Python libraries - netapp-lib - xmldict - jmespath
ONTAP	ONTAP version 9.8 +
	Two data aggregates
	NFS vlan and ifgrp created
Oracle server(s)	RHEL 7/8
	Oracle Linux 7/8
	Network interfaces for NFS, public, and optional mgmt
	Existing Oracle environment on source, and the equivalent Linux operating system at the destination (DR Site or Public Cloud)

CVO

Environment	Requirements
Ansible environment	AWX/Tower
	Ansible v.2.10 and higher
	Python 3
	Python libraries - netapp-lib - xmldict - jmespath
ONTAP	ONTAP version 9.8 +
	Two data aggregates
	NFS vlan and ifgrp created
Oracle server(s)	RHEL 7/8
	Oracle Linux 7/8
	Network interfaces for NFS, public, and optional mgmt
	Existing Oracle environment on source, and the equivalent Linux operating system at the destination (DR Site or Public Cloud)
	Set appropriate swap space on the Oracle EC2 instance, by default some EC2 instances are deployed with 0 swap

Environment	Requirements
Cloud Manager/AWS	AWS Access/Secret Key
	NetApp Cloud Manager Account
	NetApp Cloud Manager Refresh Token

Automation Details

On-Prem |

This automated deployment is designed with a single Ansible playbook that consists of three separate roles. The roles are for ONTAP, Linux, and Oracle configurations. The following table describes which tasks are being automated.

Playbook	Tasks
ontap_setup	Pre-check of the ONTAP environment
	Creation of Intercluster LIFs on source cluster (OPTIONAL)
	Creation of Intercluster LIFs on destination cluster (OPTIONAL)
	Creation of Cluster and SVM Peering
	Creation of destination SnapMirror and Initialization of designated Oracle volumes
ora_replication_cg	Enable backup mode for each database in /etc/oratab
	Snapshot taken of Oracle Binary and Database volumes
	Snapmirror Updated
	Turn off backup mode for each database in /etc/oratab
ora_replication_log	Switch current log for each database in /etc/oratab
	Snapshot taken of Oracle Log volume
	Snapmirror Updated
ora_recovery	Break SnapMirror
	Enable NFS and create junction path for Oracle volumes on the destination
	Configure DR Oracle Host
	Mount and verify Oracle volumes
	Recover and start Oracle database

CVO

This automated deployment is designed with a single Ansible playbook that consists of three separate roles. The roles are for ONTAP, Linux, and Oracle configurations. The following table describes which tasks are being automated.

Playbook	Tasks
cvo_setup	Pre-check of the environment
	AWS Configure/AWS Access Key ID/Secret Key/Default Region
	Creation of AWS Role
	Creation of NetApp Cloud Manager Connector instance in AWS
	Creation of Cloud Volumes ONTAP (CVO) instance in AWS
	Add On-Prem Source ONTAP Cluster to NetApp Cloud Manager
	Creation of destination SnapMirror and Initialization of designated Oracle volumes
ora_replication_cg	Enable backup mode for each database in /etc/oratab
	Snapshot taken of Oracle Binary and Database volumes
	Snapmirror Updated
	Turn off backup mode for each database in /etc/oratab
ora_replication_log	Switch current log for each database in /etc/oratab
	Snapshot taken of Oracle Log volume
	Snapmirror Updated
ora_recovery	Break SnapMirror
	Enable NFS and create junction path for Oracle volumes on the destination CVO
	Configure DR Oracle Host
	Mount and verify Oracle volumes
	Recover and start Oracle database

Default parameters

To simplify automation, we have preset many required Oracle parameters with default values. It is generally not necessary to change the default parameters for most deployments. A more advanced user can make changes to the default parameters with caution. The default parameters are located in each role folder under defaults directory.

License

You should read license information as stated in the Github repository. By accessing, downloading, installing, or using the content in this repository, you agree the terms of the license laid out [here](#).

Note that there are certain restrictions around producing and/or sharing any derivative works with the content in this repository. Please make sure you read the terms of the [License](#) before using the content. If you do not agree to all of the terms, do not access, download, or use the content in this repository.

After you are ready, click [here for detailed AWX/Tower procedures](#).

Step-by-step deployment procedure

This page describes the Automated Data Protection of Oracle19c on NetApp ONTAP storage.

AWX/Tower Oracle Data Protection

Create the inventory, group, hosts, and credentials for your environment

This section describes the setup of inventory, groups, hosts, and access credentials in AWX/Ansible Tower that prepare the environment for consuming NetApp automated solutions.

1. Configure the inventory.
 - a. Navigate to Resources → Inventories → Add, and click Add Inventory.
 - b. Provide the name and organization details, and click Save.
 - c. On the Inventories page, click the inventory created.
 - d. Navigate to the Groups sub-menu and click Add.
 - e. Provide the name oracle for your first group and click Save.
 - f. Repeat the process for a second group called dr_oracle.
 - g. Select the oracle group created, go to the Hosts sub-menu and click Add New Host.
 - h. Provide the IP address of the Source Oracle host's management IP, and click Save.
 - i. This process must be repeated for the dr_oracle group and add the the DR/Destination Oracle host's management IP/hostname.



Below are instructions for creating the credential types and credentials for either On-Prem with ONTAP, or CVO on AWS.

On-Prem

1. Configure the credentials.
2. Create Credential Types. For solutions involving ONTAP, you must configure the credential type to match username and password entries.
 - a. Navigate to Administration → Credential Types, and click Add.
 - b. Provide the name and description.
 - c. Paste the following content in Input Configuration:

```
fields:  
  - id: dst_cluster_username  
    type: string  
    label: Destination Cluster Username  
  - id: dst_cluster_password  
    type: string  
    label: Destination Cluster Password  
    secret: true  
  - id: src_cluster_username  
    type: string  
    label: Source Cluster Username  
  - id: src_cluster_password  
    type: string  
    label: Source Cluster Password  
    secret: true
```

- d. Paste the following content into Injector Configuration and then click Save:

```
extra_vars:  
  dst_cluster_username: '{{ dst_cluster_username }}'  
  dst_cluster_password: '{{ dst_cluster_password }}'  
  src_cluster_username: '{{ src_cluster_username }}'  
  src_cluster_password: '{{ src_cluster_password }}'
```

3. Create Credential for ONTAP
 - a. Navigate to Resources → Credentials, and click Add.
 - b. Enter the name and organization details for the ONTAP Credentials
 - c. Select the credential type that was created in the previous step.
 - d. Under Type Details, enter the Username and Password for your Source and Destination Clusters.
 - e. Click Save
4. Create Credential for Oracle
 - a. Navigate to Resources → Credentials, and click Add.
 - b. Enter the name and organization details for Oracle

- c. Select the Machine credential type.
- d. Under Type Details, enter the Username and Password for the Oracle hosts.
- e. Select the correct Privilege Escalation Method, and enter the username and password.
- f. Click Save
- g. Repeat process if needed for a different credential for the dr_oracle host.

CVO

1. Configure the credentials.
2. Create credential types. For solutions involving ONTAP, you must configure the credential type to match username and password entries, we will also add entries for Cloud Central and AWS.
 - a. Navigate to Administration → Credential Types, and click Add.
 - b. Provide the name and description.
 - c. Paste the following content in Input Configuration:

```
fields:
- id: dst_cluster_username
  type: string
  label: CVO Username
- id: dst_cluster_password
  type: string
  label: CVO Password
  secret: true
- id: cvo_svm_password
  type: string
  label: CVO SVM Password
  secret: true
- id: src_cluster_username
  type: string
  label: Source Cluster Username
- id: src_cluster_password
  type: string
  label: Source Cluster Password
  secret: true
- id: regular_id
  type: string
  label: Cloud Central ID
  secret: true
- id: email_id
  type: string
  label: Cloud Manager Email
  secret: true
- id: cm_password
  type: string
  label: Cloud Manager Password
  secret: true
- id: access_key
  type: string
  label: AWS Access Key
  secret: true
- id: secret_key
  type: string
  label: AWS Secret Key
  secret: true
- id: token
  type: string
  label: Cloud Central Refresh Token
  secret: true
```

d. Paste the following content into Injector Configuration and click Save:

```
extra_vars:
  dst_cluster_username: '{{ dst_cluster_username }}'
  dst_cluster_password: '{{ dst_cluster_password }}'
  cvo_svm_password: '{{ cvo_svm_password }}'
  src_cluster_username: '{{ src_cluster_username }}'
  src_cluster_password: '{{ src_cluster_password }}'
  regular_id: '{{ regular_id }}'
  email_id: '{{ email_id }}'
  cm_password: '{{ cm_password }}'
  access_key: '{{ access_key }}'
  secret_key: '{{ secret_key }}'
  token: '{{ token }}'
```

3. Create Credential for ONTAP/CVO/AWS

- a. Navigate to Resources → Credentials, and click Add.
- b. Enter the name and organization details for the ONTAP Credentials
- c. Select the credential type that was created in the previous step.
- d. Under Type Details, enter the Username and Password for your Source and CVO Clusters, Cloud Central/Manager, AWS Access/Secret Key and Cloud Central Refresh Token.
- e. Click Save

4. Create Credential for Oracle (Source)

- a. Navigate to Resources → Credentials, and click Add.
- b. Enter the name and organization details for Oracle host
- c. Select the Machine credential type.
- d. Under Type Details, enter the Username and Password for the Oracle hosts.
- e. Select the correct Privilege Escalation Method, and enter the username and password.
- f. Click Save

5. Create Credential for Oracle Destination

- a. Navigate to Resources → Credentials, and click Add.
- b. Enter the name and organization details for the DR Oracle host
- c. Select the Machine credential type.
- d. Under Type Details, enter the Username (ec2-user or if you have changed it from default enter that), and the SSH Private Key
- e. Select the correct Privilege Escalation Method (sudo), and enter the username and password if needed.
- f. Click Save

Create a project

1. Go to Resources → Projects, and click Add.

- a. Enter the name and organization details.
- b. Select Git in the Source Control Credential Type field.
- c. enter https://github.com/NetApp-Automation/na_oracle19c_data_protection.git as the source control URL.
- d. Click Save.
- e. The project might need to sync occasionally when the source code changes.

Configure global variables

Variables defined in this section apply to all Oracle hosts, databases, and the ONTAP cluster.

1. Input your environment-specific parameters in following embedded global variables or vars form.



The items in blue must be changed to match your environment.

On-Prem

```
# Oracle Data Protection global user configuration variables
# Ontap env specific config variables
hosts_group: "ontap"
ca_signed_certs: "false"

# Inter-cluster LIF details
src_nodes:
  - "AFF-01"
  - "AFF-02"

dst_nodes:
  - "DR-AFF-01"
  - "DR-AFF-02"

create_source_intercluster_lifs: "yes"

source_intercluster_network_port_details:
  using_dedicated_ports: "yes"
  using_ifgrp: "yes"
  using_vlans: "yes"
  failover_for_shared_individual_ports: "yes"
  ifgrp_name: "a0a"
  vlan_id: "10"
  ports:
    - "e0b"
    - "e0g"
  broadcast_domain: "NFS"
  ipspace: "Default"
  failover_group_name: "iclifs"

source_intercluster_lif_details:
  - name: "icl_1"
    address: "10.0.0.1"
    netmask: "255.255.255.0"
    home_port: "a0a-10"
    node: "AFF-01"
  - name: "icl_2"
    address: "10.0.0.2"
    netmask: "255.255.255.0"
    home_port: "a0a-10"
    node: "AFF-02"

create_destination_intercluster_lifs: "yes"
```

```
destination_intercluster_network_port_details:
  using_dedicated_ports: "yes"
  using_ifgrp: "yes"
  using_vlans: "yes"
  failover_for_shared_individual_ports: "yes"
  ifgrp_name: "a0a"
  vlan_id: "10"
  ports:
    - "e0b"
    - "e0g"
  broadcast_domain: "NFS"
  ipspace: "Default"
  failover_group_name: "iclifs"

destination_intercluster_lif_details:
  - name: "icl_1"
    address: "10.0.0.3"
    netmask: "255.255.255.0"
    home_port: "a0a-10"
    node: "DR-AFF-01"
  - name: "icl_2"
    address: "10.0.0.4"
    netmask: "255.255.255.0"
    home_port: "a0a-10"
    node: "DR-AFF-02"

# Variables for SnapMirror Peering
passphrase: "your-passphrase"

# Source & Destination List
dst_cluster_name: "dst-cluster-name"
dst_cluster_ip: "dst-cluster-ip"
dst_vserver: "dst-vserver"
dst_nfs_lif: "dst-nfs-lif"
src_cluster_name: "src-cluster-name"
src_cluster_ip: "src-cluster-ip"
src_vserver: "src-vserver"

# Variable for Oracle Volumes and SnapMirror Details
cg_snapshot_name_prefix: "oracle"
src_orabinary_vols:
  - "binary_vol"
src_db_vols:
  - "db_vol"
src_archivelog_vols:
  - "log_vol"
```

```

snapmirror_policy: "async_policy_oracle"

# Export Policy Details
export_policy_details:
  name: "nfs_export_policy"
  client_match: "0.0.0.0/0"
  ro_rule: "sys"
  rw_rule: "sys"

# Linux env specific config variables
mount_points:
  - "/u01"
  - "/u02"
  - "/u03"
hugepages_nr: "1234"
redhat_sub_username: "xxx"
redhat_sub_password: "xxx"

# DB env specific install and config variables
recovery_type: "scn"
control_files:
  - "/u02/oradata/CDB2/control01.ctl"
  - "/u03/orareco/CDB2/control02.ctl"

```

CVO

```

#####
### Ontap env specific config variables ###
#####

#Inventory group name
#Default inventory group name - "ontap"
#Change only if you are changing the group name either in
inventory/hosts file or in inventory groups in case of AWX/Tower
hosts_group: "ontap"

#CA_signed_certificates (ONLY CHANGE to "true" IF YOU ARE USING CA
SIGNED CERTIFICATES)
ca_signed_certs: "false"

#Names of the Nodes in the Source ONTAP Cluster
src_nodes:
  - "AFF-01"
  - "AFF-02"

#Names of the Nodes in the Destination CVO Cluster

```

```

dst_nodes:
  - "DR-AFF-01"
  - "DR-AFF-02"

#Define whether or not to create intercluster lifs on source cluster
(ONLY CHANGE to "No" IF YOU HAVE ALREADY CREATED THE INTERCLUSTER LIFS)
create_source_intercluster_lifs: "yes"

source_intercluster_network_port_details:
  using_dedicated_ports: "yes"
  using_ifgrp: "yes"
  using_vlans: "yes"
  failover_for_shared_individual_ports: "yes"
  ifgrp_name: "a0a"
  vlan_id: "10"
  ports:
    - "e0b"
    - "e0g"
  broadcast_domain: "NFS"
  ipspace: "Default"
  failover_group_name: "iclifs"

source_intercluster_lif_details:
  - name: "icl_1"
    address: "10.0.0.1"
    netmask: "255.255.255.0"
    home_port: "a0a-10"
    node: "AFF-01"
  - name: "icl_2"
    address: "10.0.0.2"
    netmask: "255.255.255.0"
    home_port: "a0a-10"
    node: "AFF-02"

#####
### CVO Deployment Variables ###
#####

##### Access Keys Variables #####

# Region where your CVO will be deployed.
region_deploy: "us-east-1"

##### CVO and Connector Vars #####

# AWS Managed Policy required to give permission for IAM role creation.

```

```

aws_policy: "arn:aws:iam::1234567:policy/OCCM"

# Specify your aws role name, a new role is created if one already does
not exist.
aws_role_name: "arn:aws:iam::1234567:policy/OCCM"

# Name your connector.
connector_name: "awx_connector"

# Name of the key pair generated in AWS.
key_pair: "key_pair"

# Name of the Subnet that has the range of IP addresses in your VPC.
subnet: "subnet-12345"

# ID of your AWS security group that allows access to on-prem
resources.
security_group: "sg-123123123"

# Your Cloud Manager Account ID.
account: "account-A23123A"

# Name of the your CVO instance
cvo_name: "test_cvo"

# ID of the VPC in AWS.
vpc: "vpc-123123123"

#####
#####
# Variables for - Add on-prem ONTAP to Connector in Cloud Manager
#####
#####

# For Federated users, Client ID from API Authentication Section of
Cloud Central to generate access token.
sso_id: "123123123123123123123"

# For regular access with username and password, please specify "pass"
as the connector_access. For SSO users, use "refresh_token" as the
variable.
connector_access: "pass"

#####
#####
# Variables for SnapMirror Peering
#####

```

```

#####
passphrase: "your-passphrase"

#####
#####
# Source & Destination List
#####
#####
#Please Enter Destination Cluster Name
dst_cluster_name: "dst-cluster-name"

#Please Enter Destination Cluster (Once CVO is Created Add this
Variable to all templates)
dst_cluster_ip: "dst-cluster-ip"

#Please Enter Destination SVM to create mirror relationship
dst_vserver: "dst-vserver"

#Please Enter NFS Lif for dst vserver (Once CVO is Created Add this
Variable to all templates)
dst_nfs_lif: "dst-nfs-lif"

#Please Enter Source Cluster Name
src_cluster_name: "src-cluster-name"

#Please Enter Source Cluster
src_cluster_ip: "src-cluster-ip"

#Please Enter Source SVM
src_vserver: "src-vserver"

#####
#####
# Variable for Oracle Volumes and SnapMirror Details
#####
#####
#Please Enter Source Snapshot Prefix Name
cg_snapshot_name_prefix: "oracle"

#Please Enter Source Oracle Binary Volume(s)
src_orabinary_vols:
- "binary_vol"
#Please Enter Source Database Volume(s)
src_db_vols:
- "db_vol"
#Please Enter Source Archive Volume(s)

```

```

src_archivelog_vols:
  - "log_vol"
#Please Enter Destination Snapmirror Policy
snapmirror_policy: "async_policy_oracle"

#####
#####
# Export Policy Details
#####
#####
#Enter the destination export policy details (Once CVO is Created Add
this Variable to all templates)
export_policy_details:
  name: "nfs_export_policy"
  client_match: "0.0.0.0/0"
  ro_rule: "sys"
  rw_rule: "sys"

#####
#####
### Linux env specific config variables ###
#####
#####

#NFS Mount points for Oracle DB volumes
mount_points:
  - "/u01"
  - "/u02"
  - "/u03"

# Up to 75% of node memory size divided by 2mb. Consider how many
databases to be hosted on the node and how much ram to be allocated to
each DB.
# Leave it blank if hugepage is not configured on the host.
hugepages_nr: "1234"

# RedHat subscription username and password
redhat_sub_username: "xxx"
redhat_sub_password: "xxx"

#####
### DB env specific install and config variables ###
#####
#Recovery Type (leave as scn)
recovery_type: "scn"

```

```
#Oracle Control Files
control_files:
  - "/u02/oradata/CDB2/control01.ctl"
  - "/u03/orareco/CDB2/control02.ctl"
```

Automation Playbooks

There are four separate playbooks that need to be ran.

1. Playbook for Setting up your environment, On-Prem or CVO.
2. Playbook for replicating Oracle Binaries and Databases on a schedule
3. Playbook for replicating Oracle Logs on a schedule
4. Playbook for Recovering your database on a destination host

ONTAP/CVO Setup

ONTAP and CVO Setup

Configure and launch the job template.

1. Create the job template.
 - a. Navigate to Resources → Templates → Add and click Add Job Template.
 - b. Enter the name ONTAP/CVO Setup
 - c. Select the Job type; Run configures the system based on a playbook.
 - d. Select the corresponding inventory, project, playbook, and credentials for the playbook.
 - e. Select the `ontap_setup.yml` playbook for an On-Prem environment or select the `cvo_setup.yml` for replicating to a CVO instance.
 - f. Paste global variables copied from step 4 into the Template Variables field under the YAML tab.
 - g. Click Save.
2. Launch the job template.
 - a. Navigate to Resources → Templates.
 - b. Click the desired template and then click Launch.



We will use this template and copy it out for the other playbooks.

Replication For Binary and Database Volumes

Scheduling the Binary and Database Replication Playbook

Configure and launch the job template.

1. Copy the previously created job template.
 - a. Navigate to Resources → Templates.
 - b. Find the ONTAP/CVO Setup Template, and on the far right click on Copy Template
 - c. Click Edit Template on the copied template, and change the name to Binary and Database Replication Playbook.
 - d. Keep the same inventory, project, credentials for the template.
 - e. Select the `ora_replication_cg.yml` as the playbook to be executed.
 - f. The variables will remain the same, but the CVO cluster IP will need to be set in the variable `dst_cluster_ip`.
 - g. Click Save.
2. Schedule the job template.
 - a. Navigate to Resources → Templates.
 - b. Click the Binary and Database Replication Playbook template and then click Schedules at the top set of options.
 - c. Click Add, add Name Schedule for Binary and Database Replication, choose the Start date/time at the beginning of the hour, choose your Local time zone, and Run frequency. Run frequency will be often the SnapMirror replication will be updated.



A separate schedule will be created for the Log volume replication, so that it can be replicated on a more frequent cadence.

Replication for Log Volumes

Scheduling the Log Replication Playbook

Configure and launch the job template.

1. Copy the previously created job template.
 - a. Navigate to Resources → Templates.
 - b. Find the ONTAP/CVO Setup Template, and on the far right click on Copy Template
 - c. Click Edit Template on the copied template, and change the name to Log Replication Playbook.
 - d. Keep the same inventory, project, credentials for the template.
 - e. Select the ora_replication_logs.yml as the playbook to be executed.
 - f. The variables will remain the same, but the CVO cluster IP will need to be set in the variable `dst_cluster_ip`.
 - g. Click Save.
2. Schedule the job template.
 - a. Navigate to Resources → Templates.
 - b. Click the Log Replication Playbook template and then click Schedules at the top set of options.
 - c. Click Add, add Name Schedule for Log Replication, choose the Start date/time at the beginning of the hour, choose your Local time zone, and Run frequency. Run frequency will be often the SnapMirror replication will be updated.



It is recommended to set the log schedule to update every hour to ensure the recovery to the last hourly update.

Restore and Recover Database

Scheduling the Log Replication Playbook

Configure and launch the job template.

1. Copy the previously created job template.
 - a. Navigate to Resources → Templates.
 - b. Find the ONTAP/CVO Setup Template, and on the far right click on Copy Template
 - c. Click Edit Template on the copied template, and change the name to Restore and Recovery Playbook.
 - d. Keep the same inventory, project, credentials for the template.
 - e. Select the ora_recovery.yml as the playbook to be executed.
 - f. The variables will remain the same, but the CVO cluster IP will need to be set in the variable `dst_cluster_ip`.
 - g. Click Save.



This playbook will not be ran until you are ready to restore your database at the remote site.

Recovering Oracle Database

1. On-premises production Oracle databases data volumes are protected via NetApp SnapMirror replication to either a redundant ONTAP cluster in secondary data center or Cloud Volume ONTAP in public cloud. In a fully configured disaster recovery environment, recovery compute instances in secondary data center or public cloud are standby and ready to recover the production database in the case of a disaster. The standby compute instances are kept in sync with on-prem instances by running parallel updates on OS kernel patch or upgrade in a lockstep.
2. In this solution demonstrated, Oracle binary volume is replicated to target and mounted at target instance to bring up Oracle software stack. This approach to recover Oracle has advantage over a fresh installation of Oracle at last minute when a disaster occurred. It guarantees Oracle installation is fully in sync with current on-prem production software installation and patch levels etc. However, this may or may not have additional software licensing implication for the replicated Oracle binary volume at recovery site depending on how the software licensing is structured with Oracle. User is recommended to check with its software licensing personnel to assess the potential Oracle licensing requirement before deciding to use the same approach.
3. The standby Oracle host at the destination is configured with the Oracle prerequisite configurations.
4. The SnapMirrors are broken and the volumes are made writable and mounted to the standby Oracle host.
5. The Oracle recovery module performs following tasks to recovery and startup Oracle at recovery site after all DB volumes are mounted at standby compute instance.
 - a. Sync the control file: We deployed duplicate Oracle control files on different database volume to protect critical database control file. One is on the data volume and another is on log volume. Since data and log volumes are replicated at different frequency, they will be out of sync at the time of recovery.
 - b. Relink Oracle binary: Since the Oracle binary is relocated to a new host, it needs a relink.
 - c. Recover Oracle database: The recovery mechanism retrieves last System Change Number in last available archived log in Oracle log volume from control file and recovers Oracle database to recoup all business transactions that was able to be replicated to DR site at the time of failure. The database is then started up in a new incarnation to carry on user connections and business transaction at recovery site.



Before running the Recovering playbook make sure you have the following:
Make sure it copy over the `/etc/oratab` and `/etc/oralnst.loc` from the source Oracle host to the destination host

TR-4794: Oracle databases on NetApp EF-Series

Mitch Blackburn, Ebin Kadavy, NetApp

TR-4794 is intended to help storage administrators and database administrators successfully deploy Oracle on NetApp EF-Series storage.

[TR-4794: Oracle databases on NetApp EF-Series](#)

Copyright information

Copyright © 2024 NetApp, Inc. All Rights Reserved. Printed in the U.S. No part of this document covered by copyright may be reproduced in any form or by any means—graphic, electronic, or mechanical, including photocopying, recording, taping, or storage in an electronic retrieval system—without prior written permission of the copyright owner.

Software derived from copyrighted NetApp material is subject to the following license and disclaimer:

THIS SOFTWARE IS PROVIDED BY NETAPP “AS IS” AND WITHOUT ANY EXPRESS OR IMPLIED WARRANTIES, INCLUDING, BUT NOT LIMITED TO, THE IMPLIED WARRANTIES OF MERCHANTABILITY AND FITNESS FOR A PARTICULAR PURPOSE, WHICH ARE HEREBY DISCLAIMED. IN NO EVENT SHALL NETAPP BE LIABLE FOR ANY DIRECT, INDIRECT, INCIDENTAL, SPECIAL, EXEMPLARY, OR CONSEQUENTIAL DAMAGES (INCLUDING, BUT NOT LIMITED TO, PROCUREMENT OF SUBSTITUTE GOODS OR SERVICES; LOSS OF USE, DATA, OR PROFITS; OR BUSINESS INTERRUPTION) HOWEVER CAUSED AND ON ANY THEORY OF LIABILITY, WHETHER IN CONTRACT, STRICT LIABILITY, OR TORT (INCLUDING NEGLIGENCE OR OTHERWISE) ARISING IN ANY WAY OUT OF THE USE OF THIS SOFTWARE, EVEN IF ADVISED OF THE POSSIBILITY OF SUCH DAMAGE.

NetApp reserves the right to change any products described herein at any time, and without notice. NetApp assumes no responsibility or liability arising from the use of products described herein, except as expressly agreed to in writing by NetApp. The use or purchase of this product does not convey a license under any patent rights, trademark rights, or any other intellectual property rights of NetApp.

The product described in this manual may be protected by one or more U.S. patents, foreign patents, or pending applications.

LIMITED RIGHTS LEGEND: Use, duplication, or disclosure by the government is subject to restrictions as set forth in subparagraph (b)(3) of the Rights in Technical Data -Noncommercial Items at DFARS 252.227-7013 (FEB 2014) and FAR 52.227-19 (DEC 2007).

Data contained herein pertains to a commercial product and/or commercial service (as defined in FAR 2.101) and is proprietary to NetApp, Inc. All NetApp technical data and computer software provided under this Agreement is commercial in nature and developed solely at private expense. The U.S. Government has a non-exclusive, non-transferrable, nonsublicensable, worldwide, limited irrevocable license to use the Data only in connection with and in support of the U.S. Government contract under which the Data was delivered. Except as provided herein, the Data may not be used, disclosed, reproduced, modified, performed, or displayed without the prior written approval of NetApp, Inc. United States Government license rights for the Department of Defense are limited to those rights identified in DFARS clause 252.227-7015(b) (FEB 2014).

Trademark information

NETAPP, the NETAPP logo, and the marks listed at <http://www.netapp.com/TM> are trademarks of NetApp, Inc. Other company and product names may be trademarks of their respective owners.