



Pumps for Water Resources

Source Water and Transmission • Treatment and Distribution • Wastewater • Flood Control, Dry Docks and Drainage • Irrigation • Desalination



Experience In Motion



Gain control with reliable and efficient water solutions

As the water industry faces escalating supply and demand challenges related to global population growth, increased consumption and urbanization, plant operators can partner with Flowserve to provide reliable and efficient solutions.

Customers around the world rely on proven Flowserve pumps, valves, seals, and automation equipment and systems. They leverage our unmatched engineering expertise, project management and aftermarket services to process and distribute fresh water in major municipal and industrial projects.

Flowserve solutions also protect cities from rising sea levels and flooding from extreme weather, and support the world's largest drainage and wastewater treatment processes.

Source water and water transmission

Moving water from its sources to treatment or distribution facilities requires dependable, high-volume pumps. To achieve the greatest efficiency, economy and dependability, turn to the standards of the water industry: Flowserve pumps.

Our customers — from utilities and contractors to engineers and others — have experienced decades of reliable service in the water resources market. We're here to keep your operations flowing with high efficiency.

Water treatment and distribution

You may be challenged by the need to lower costs, peak flow events, depth of service or space limitations. We can help.

Flowserve manufactures a wide range of flow control products and system designs. Our experts can provide you with an off-the-shelf solution or build one that more perfectly fits your needs.

Municipalities, private utilities, contractors and consulting engineers rely on Flowserve. We've supported water treatment and distribution operators for decades. Partner with our water specialists to design, construct and operate the best possible solutions that match your challenges.

Wastewater

Significant health, legal, environmental and economic risks can result from wastewater system failures. Plant operators must be able to trust both their fluid motion and control solutions supplier and their equipment. And that's why so many wastewater treatment plant professionals count on Flowserve for robust, reliable pumps used in the collection and treatment of municipal and industrial wastewater.





Flood control, dry docks and drainage

Reliability is an essential characteristic of pumps used in flood control and drainage applications. So is sufficient capacity. Flowserve offers high-capacity pumps for on/off cycling and continuous operation for the evacuation of water due to seepage, runoff and natural forces. Our engineers can also work alongside customers to design custom configurations built for unique needs.

Irrigation

Securing and distributing water to turn arid land into agriculturally productive farms, housing and recreation sites require reliable and readily available pumping solutions to keep irrigation operations running. Whether drawn from surface or subsurface sources or the final effluent of sewage treatment plants, Flowserve pumps effectively secure and distribute essential water.

Desalination

In designing modern desalination plants, cost-effective water production, energy consumption and system availability are major drivers.

With Flowserve as a partner, customers get complete, integrated flow control systems that are energy-efficient and scalable, regardless of the desalination process.

Committed to the complete pump system lifecycle

Water system owners, operators and end users depend on solutions that add value and reduce costs throughout the lifecycle of pumping systems.

That's why, for more than two centuries, they have partnered with Flowserve to respond to the dynamic business conditions that affect them and improve efficiency, maximize throughput, and control process quality. Whether customers need on-site technical assistance, equipment upgrades, or broader project planning with full turnkey responsibility, Flowserve delivers professional, reliable results.





Source water and water transmission

Moving water from its sources to treatment or distribution facilities requires dependable, high-volume pumps. Flowserve has long, proven performance in these vital operations.

Flowserve regularly supplies pumps capable of moving fluids with high flow and capacity using customized hydraulics (flow and head). These dependable workhorses are the standards for efficiency and operating economy in an industry where these considerations are paramount.



Source water

Surface water intake applications from streams, rivers, lakes and man-made reservoirs typically require a wide range of flows and pressures. Flowserve offers a complete line of vertical and horizontal pumps for these services.

Groundwater and deep well applications frequently present pumping challenges. No other company provides a broader selection of vertical turbine, line-shaft and submersible motor pump solutions than Flowserve.

Pump types

- Vertical turbine, wet-pit
- Vertical, wet-pit, double suction
- Vertical, wet-pit, axial or mixed flow
- Deep well submersible pumps and motors

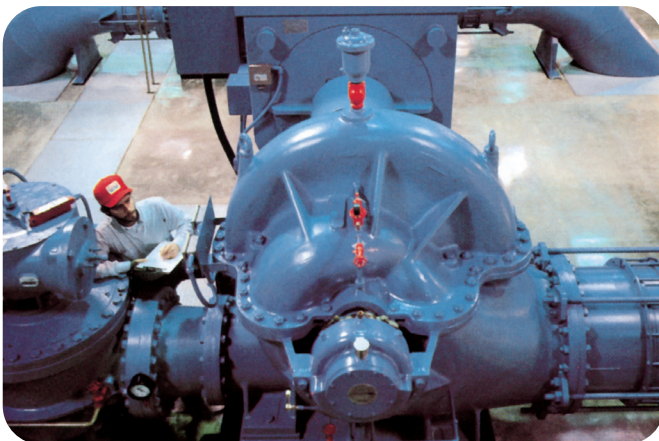

Water transmission

Transporting water to treatment plants is typically handled by horizontal split-case and vertical turbine pumps. These proven, robust pumps are capable of continuous or intermittent operation over a wide range of flows and pressures required to meet system loads.

Pump types

- Between bearings, axially split
- Overhung, end suction
- Overhung, multistage, end suction
- Between bearings, ring section, multistage
- Vertical turbine, double case

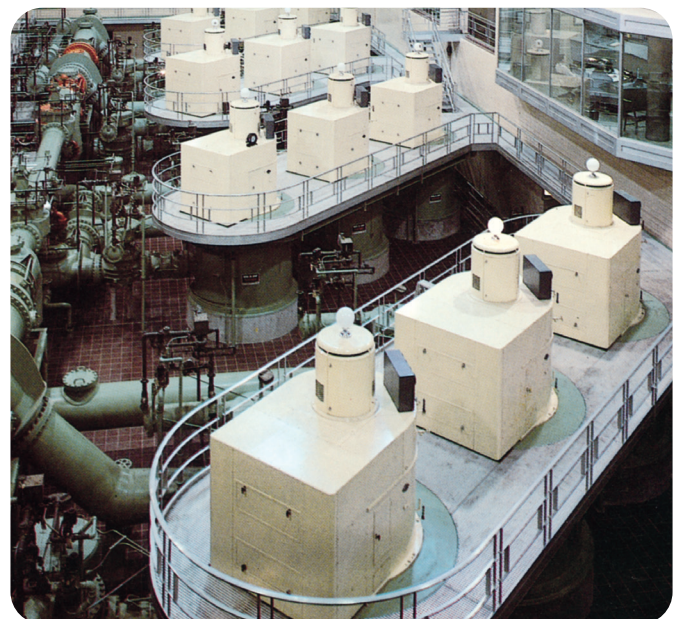



Water treatment and water distribution

Water treatment services such as filtration, chemical injection and desalination by reverse osmosis (RO) require special pumps with widely varying capacities and pressures.

That's why plant operators rely on Flowserve to provide a broad equipment portfolio and the necessary expertise to select the right pumps and systems to meet exact service requirements.

Configurations from between bearings multistage to vertical turbines from Flowserve are designed and built to help treat and move water efficiently and cost-effectively. And because they comply with NSF/ANSI/CAN 61 and 372, water plant operators can rest assured that their process equipment is safe for drinking water.



Water treatment

These varied and demanding services require a broad array of pump designs and types. Flowserve pumps are offered for these applications:

- Low-lift
- Sampling
- Plant water
- Wash water
- High service

Pump types

- Between bearings, axially split
- Overhung, end suction
- Vertical turbine, wet-pit
- Overhung, multistage, end suction
- Between bearings, ring section, multistage

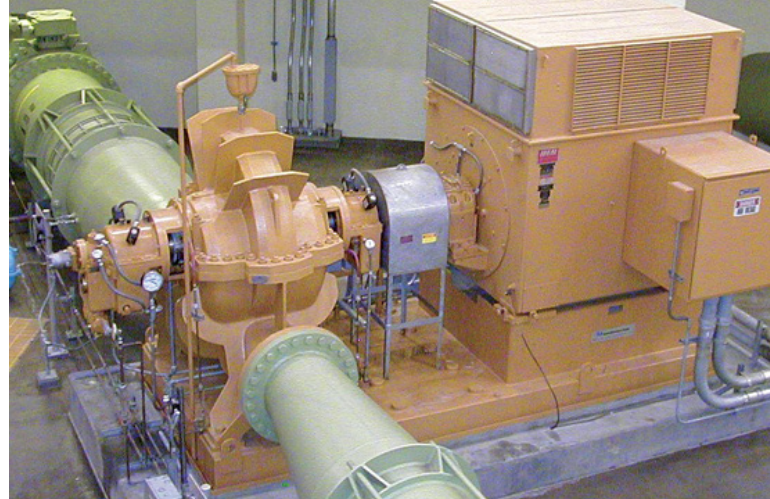

Water distribution

Flowserve offers a full complement of both vertical and horizontal pumps to maintain adequate distribution system pressures.

Pump types

- Between bearings, axially split
- Overhung, end suction
- Between bearings, ring section, multistage
- Overhung, multistage, end suction
- Deep well submersible pumps and motors
- Vertical turbine, wet-pit

Safe drinking water protects public health

Flowserve pumps meet the highest statutory, sanitary and engineering standards in the industry.

These include compliance with:

- NSF/ANSI/CAN 61 and 372 for applications that involve drinking water
- DWD 2020/2184 (Drinking Water Directive, European Union)
- DWI (Drinking Water Inspectorate, United Kingdom)
- WRAS (Water Regulations Advisory Scheme)

These standards establish requirements for “lead-free” drinking water and the amount of lead permissible in drinking water system components.

Compliance gives municipalities and consumers confidence in the safety of their drinking water.





Wastewater

Equipment failure is never an option for operators of municipal or industrial wastewater collection and treatment facilities. There are significant regulatory and financial risks, so plant operators must have robust, reliable pumping solutions.

Flowserve pumps play important roles in the treatment and purification of both municipal and industrial wastewater. These robust, reliable pumps are used throughout the collection/treatment/effluent cycle.

Providing low-maintenance, solids handling pumps is a unique strength of Flowserve. Our corrosion-resistant process pumps and other specialized pumping equipment are built to last and work hard. Oversized bearings and pump shafts, along with large solids handling hydraulics, ensure dependable operation and low maintenance.

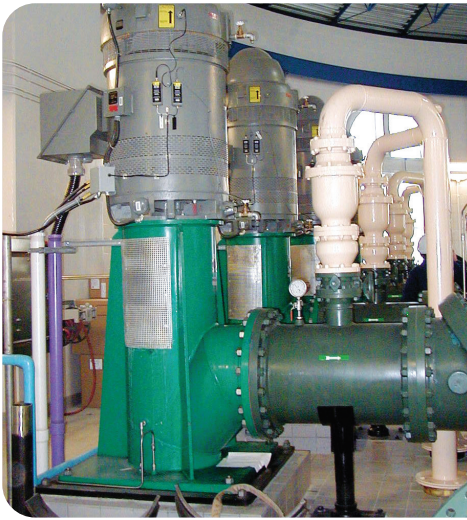

Collection

The collection and conveyance of spent water to a waste treatment plant occur in an extremely difficult environment. Pumping station equipment must handle sewage and wastes of almost every form and description, including both solids in suspension and in solution. Absolute reliability is the most critical requirement for these pumps.

Wastewater facility operators who partner with Flowserve benefit from our centuries of experience in collection applications and our highly reliable horizontal and vertical solids handling pumps.

Pump types

- Overhung, end suction
- Dry-pit, solids handling
- Immersible, solids handling
- Submersible, solids handling
- Vertical, wet-pit, solids handling

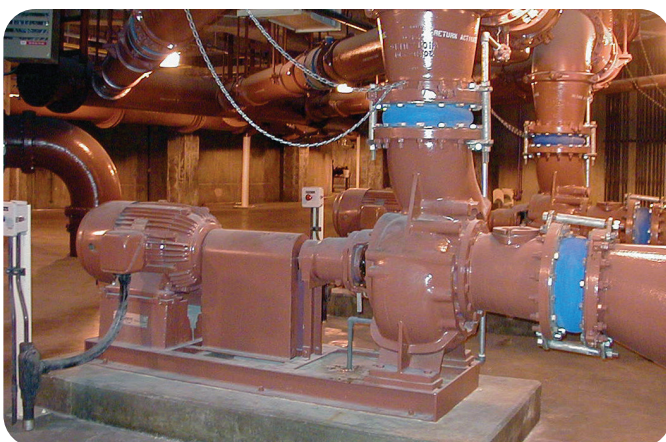

Treatment

Wastewater processes are efficiently handled by a variety of Flowserve pump models, which are supported by our solid engineering and application expertise as well as experience with thousands of installations worldwide. Applications include:

- Raw sewage
- Settled sewage
- Service water
- Return-activated sludge
- Waste-activated sludge
- Effluent
- Sequencing batch reactors
- Denitrification

Disposal and reuse

Effluent discharge and reuse throughout a treatment plant facility are also ideal applications for Flowserve pumping solutions.

Pump types

- Overhung, end suction
- Dry-pit, solids handling
- Immersible, solids handling
- Between bearings, axially split
- Vertical turbine, wet-pit
- Vertical, wet-pit, solids handling



Flood control, dry docks and drainage

Countless lives and livelihoods depend on reliable flood control and drainage. Whether it's the daily security of a major city or the ongoing reclamation of a nation's low country, Flowserve equipment and application expertise put plant operators in control.

Our flood control experience with massive water projects dates back to 1928, when we installed the first pumping station with concrete volute pumps in the Netherlands. Since then, hundreds of concrete volute pumps have been installed for flood control and drainage applications worldwide. These include the Afsluitdijk, Europe's largest flood control project, and Dallas' updated levee system, where CVP pumps were first employed in the United States.

Refer to brochure "Pumps for Flood Control and Drainage Applications" (literature number PUBR000309) on flowserve.com for more information.

Pump types

- Concrete volute
- Submersible motor pump, bottom intake (polder)
- Vertical, wet-pit, axial or mixed flow

Flowserve CVP pumps: The backbone of today's major flood control systems



Available in English, German and Dutch

Flood control

The climate is changing; as a result, the sea level is rising and extreme weather conditions are occurring more frequently. High-capacity pumps from Flowserve play a critical role in providing a complete flood control system.

Drainage

Reliability is an absolutely essential pump characteristic in drainage applications. A close second is sufficient capacity. Flowserve provides pumps for on/off cycling and continuous operation for the evacuation of water due to seepage, runoff and natural forces.

Dry docks

Large-capacity pumps can be found throughout dry dock applications for ship building, repair and marine construction. Flowserve offers a variety of pumping solutions with the reliability and versatility that dry dock operators require.

Fish-safe pumping solutions

Environmental regulations are increasingly requiring pumping station operators to implement modifications designed to protect fish, eels and other aquatic life. Our patented impeller designs and hydraulic expertise enable compliance with fish-safe standards while also reaching unsurpassed high efficiencies.

Success story

Saving the Everglades – 14 billion gallons at a time

Challenge

Agricultural runoff disrupts native animals and plants in the 607,028-hectare (1.5 million-acre) Everglades National Park in Florida. Federal and state governments have large-scale projects underway to reverse the damaging effects of polluted water and restore the delicate balance of fresh and saltwater in the area's lagoons and estuaries.

The effort requires massively powerful and reliable equipment capable of pumping billions of liters/gallons of water every day.

Solution

Flowserve provided 25 vertical pumps, with impellers from 2,438 to 3,226 mm (96 to 127 in.) in diameter, to move an estimated 64 billion liters (14 billion gallons) of water per day into filter marshes. The pumps have remained in service without interruption for more than 20 years.

Flowserve also supplied four 1,981 mm (78 in.) pumps for a separate project that will lift 3.2 billion liters (710 million gallons) of nutrient-enriched water per day into a pre-treatment reservoir.





Irrigation

Whether drawn from surface or subsurface sources or the final effluent of sewage treatment plants, highly robust pumps are needed to effectively secure and distribute essential irrigation and other agricultural and golf course applications. Vertical line shaft and submersible pumps from Flowserve reach water sources at varying depths with efficiency and reliability.

Pump types

- Surface water
 - Overhung, end suction
 - Overhung, multistage, end suction
 - Between bearings, ring section, multistage
 - Between bearings, axially split
 - Between bearings, axially split, double suction
 - Vertical turbine, wet-pit
- Groundwater
 - Deep well submersible pumps and motors
 - Vertical turbine, wet-pit
 - Vertical, wet-pit, axial or mixed flow





Desalination

As global demand for clean water accelerates, innovative Flowserve pumps, valves and energy-recovery products help to bring fresh potable and industrial water to millions of people. We deliver complete, integrated flow control systems that are energy-efficient and scalable.

As a result, plant operators can economically operate RO processes for seawater and brackish water or multistage flash (MSF) and multi-effect distillation units for high-salinity concentration applications.

Pump types

- Between bearings, axially split, multistage
- Between bearings, axially split, single stage
- Between bearings, ring section, multistage
- Overhung, end suction
- Vertical turbine, wet-pit
- Vertical, wet-pit, axial or mixed flow
- Deep well submersible pumps and motors

Energy recovery devices (ERDs)

- Isobaric pressure exchanger
- Dual work exchanger
- Energy recovery turbines

Recover more energy. Recover more savings.

Energy is the primary cost driver in any RO desalination process. That's why Flowserve designed the Flowserve FLEX™ pressure exchanger, an isobaric ERD, to be the most efficient and compact device of its type. It is able to recover more than 98% of hydraulic energy and boasts the highest unit capacity available on the market. As a result, it helps plant operators to drive down the cost of desalination by substantially reducing operating and capital costs.

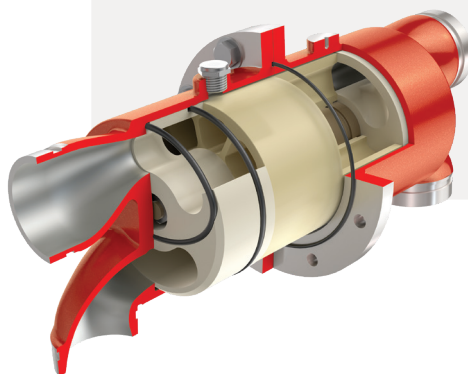

**Watch
the video!**



Vertical water pumps

Vertical turbine pumps

Single- or multistage designs with above- or below-grade discharge, enclosed or semi-open impellers, open or enclosed lineshafts, single or double case (VTP, VPC)

Operating parameters

- Flows to 13,600 m³/h (60,000 gpm)
- Heads to 1,070 m (1,450 ft)
- Pressures to 100 bar (1,450 psi)

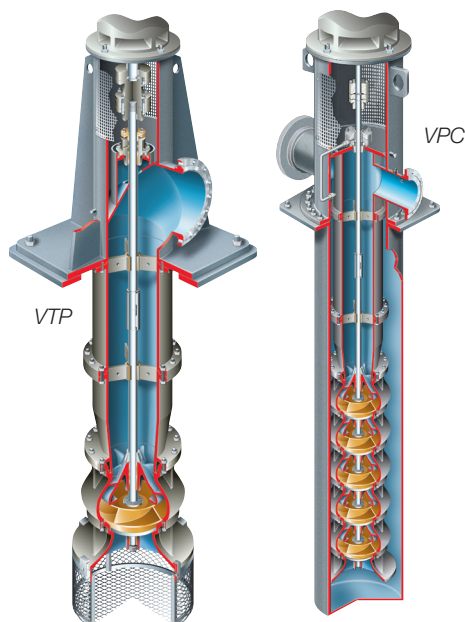

Vertical, double-suction, double volute pumps

Single- or multistage designs with heavy-wall, double volute casing, double-suction (first-stage) impeller, open or enclosed lineshafts, single or double case (QL, QLQ, QLC, QLQC)

Operating parameters

- Flows to 25,000 m³/h (110,000 gpm)
- Heads to 500 m (1,640 ft)
- Pressures to 70 bar (1,015 psi)

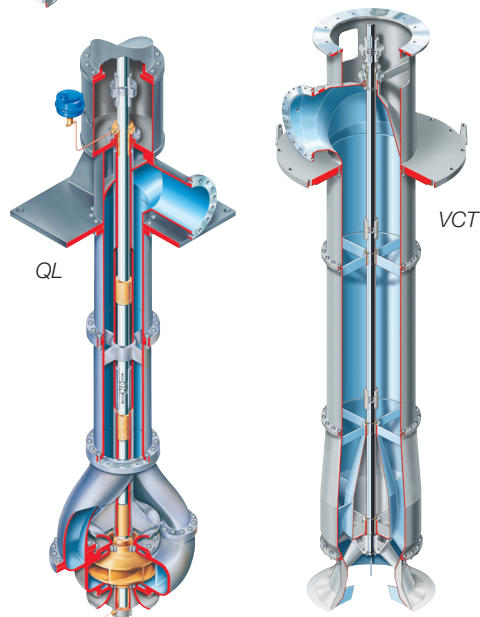

Vertical mixed or axial flow pumps

Wet-pit, single-stage pumps with above- or below-grade discharge, pullout or non-pullout construction (AFV, VCT)

Operating parameters

- Flows to 181,700 m³/h (80,000 gpm)
- Heads:
 - Axial flow (AFV): to 11 m (35 ft)
 - Mixed flow (VCT): to 110 m (350 ft)



Submersible motor pumps

Single- or multistage designs coupled with either water- or oil-filled submersible motors (Byron Jackson® SUBM with H2O water-filled motor, Byron Jackson SUBM with OIL oil-filled motor, Byron Jackson H2O+)

Operating parameters

- Flows to 4,500 m³/h (19,800 gpm)
- Heads to 800 m (2,625 ft)
- Motor sizes to 2,237 kW (3,000 hp)
- Speeds from 900 to 3,600 rpm

Concrete volute pumps

Removable metallic pump pullout unit within a concrete volute; suction bell connected to preformed high-efficiency, vortex-free concrete suction box; open or closed, mixed flow impeller (CVP)

Operating parameters

- Flows to 115,000 m³/h (500,000 gpm)
- Heads to 45 m (147 ft)



Byron Jackson H2O+

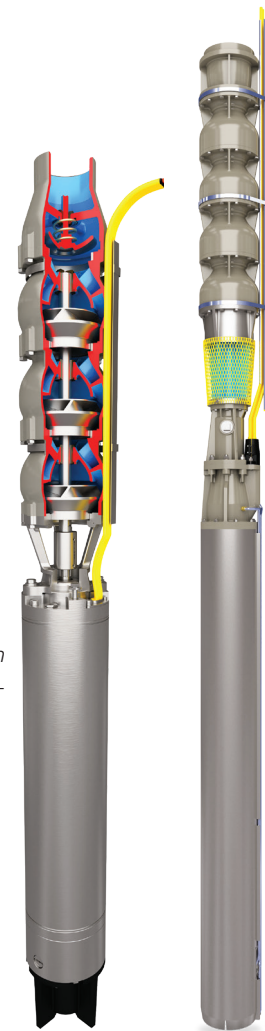

Byron Jackson SUBM

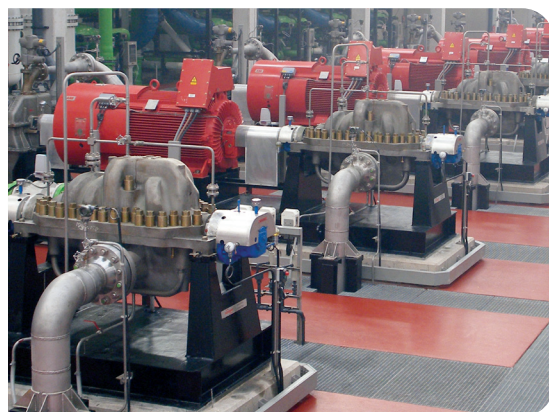
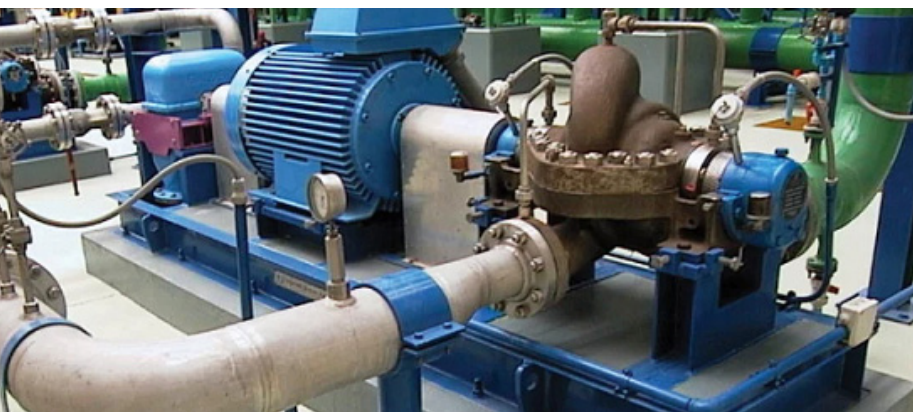

Horizontal water pumps

Between bearings, single-stage pumps

Axially split, double volute casing with double-suction impeller; vertical mounting and bottom suction available (LR, LRV, LNN, LNNV, DVSH-RO)

Operating parameters

- Flows to 30,000 m³/h (132,000 gpm)
- Heads to 700 m (2,297 ft)
- Pressures to 150 bar (2,175 psi)

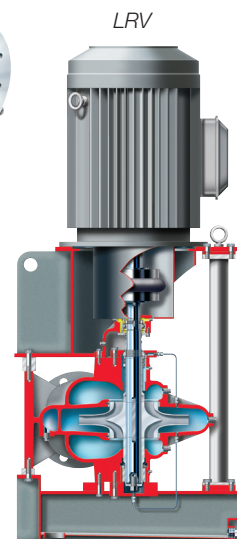
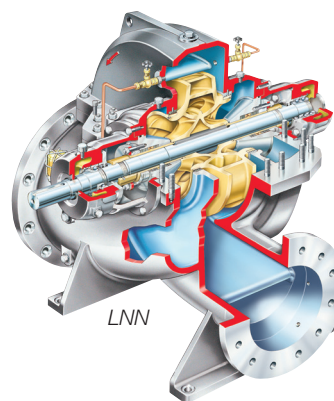

Between bearings, two-stage pumps

Axially split, two-stage pumps; back-to-back impellers (LLR, UZDL)

Operating parameters

- Flows to 295 m³/h (1,300 gpm)
- Heads to 290 m (950 ft)
- Pressures to 31 bar (450 psi)

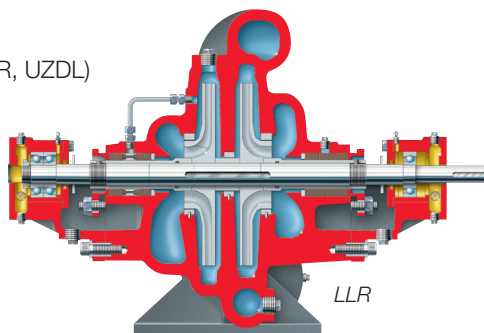

Radially split, multistage pumps

Between bearings, multistage, ring section, diffuser design with variable flange orientation; vertical mounting available (NM)

Operating parameters

- Flows to 3,000 m³/h (13,210 gpm)
- Heads to 1,250 m (4,110 ft)
- Pressures to 150 bar (2,175 psi)

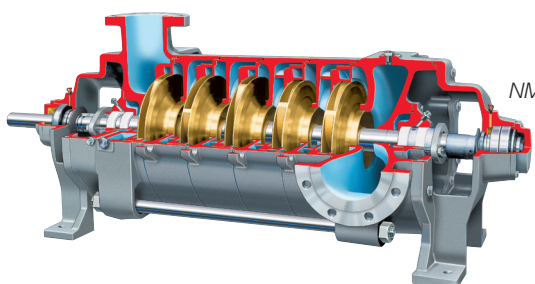

Axially split, multistage pumps

Between bearings, double volute casing with side suction and side discharge (DMX-RO, DMX)

Operating parameters

- Flows to 5,678 m³/h (25,000 gpm)
- Heads to 2,712 m (8,900 ft)
- Pressures to 275 bar (4,000 psi)

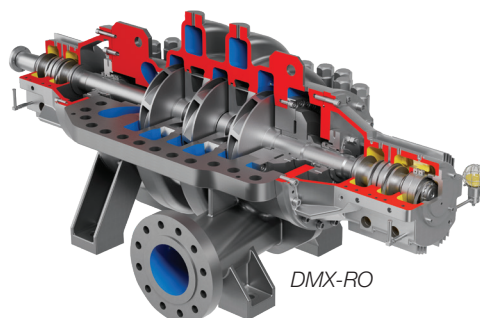

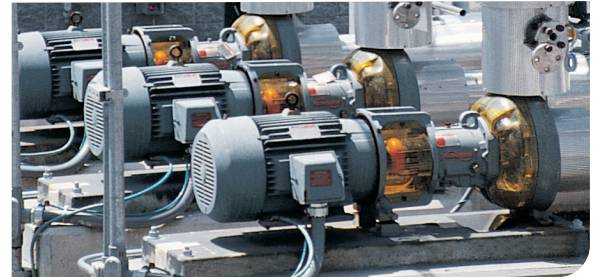

Overhung, end suction pumps

Horizontal, single-stage, end suction, frame mounted pumps conforming to:

- ASME B73.1
- ISO 2858 dimensional and ISO 5199 design criteria
- EN733 and DIN 24 255

Optional low-flow, self-priming, close coupled, in-line and recessed impeller configurations available (Durco Mark 3, Durco Mark 3 ISO, ME, MEN, DS-RO)

Operating parameters

- Flows to 1,000 m³/h (48,432 gpm)
- Heads to 215 m (700 ft)
- Pressures to 27 bar (400 psi)

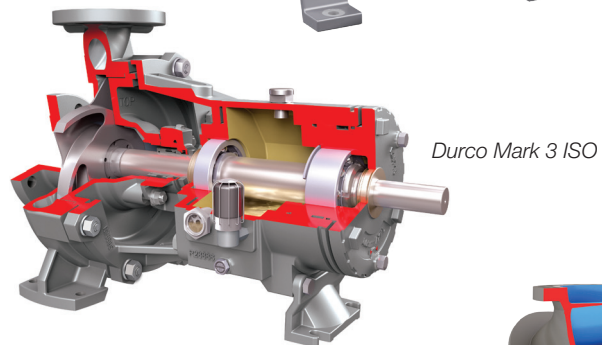
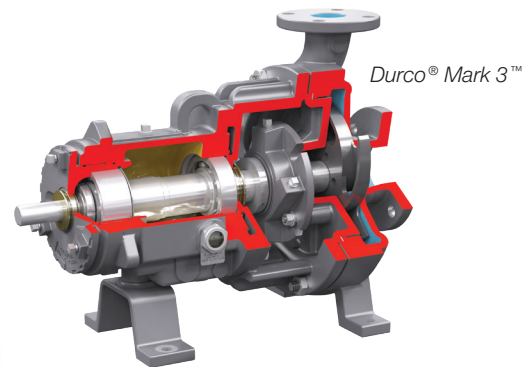

Overhung, multistage, end suction pumps

Horizontal, multistage, diffuser pump; vertical and close coupled configurations available (FP, MSL, MSM, MSC)

Operating parameters

- Flows to 600 m³/h (2,650 gpm)
- Heads to 250 m (820 ft)
- Pressures to 25 bar (365 psi)

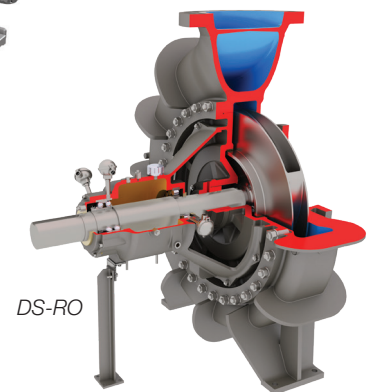
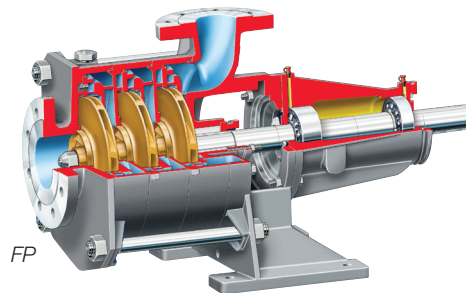

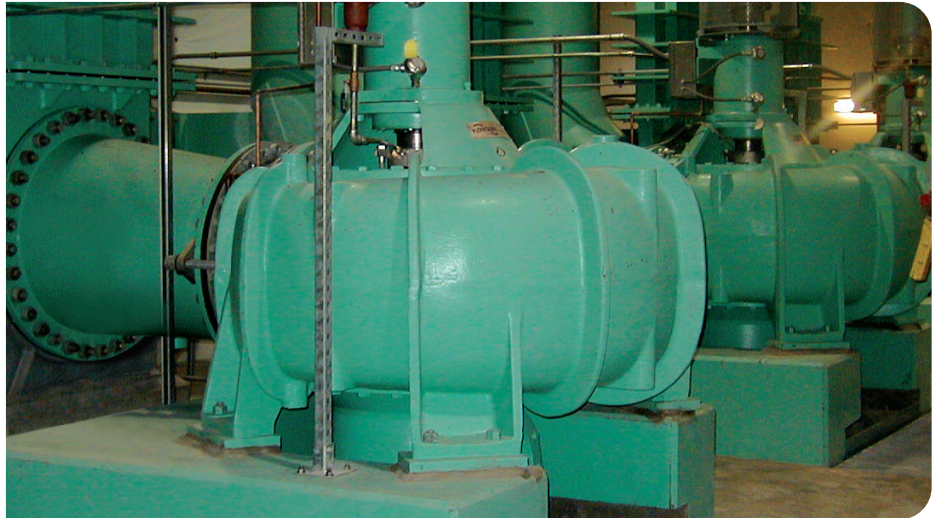

Solids handling pumps

Dry-pit, solids handling pumps

Overhung, single-stage, end suction pumps with enclosed impellers; horizontal frame mounted, vertical frame mounted or independently mounted motor with extended shafting (MN, MF)

Operating parameters

- Flows to 45,500 m³/h (200,000 gpm)
- Heads to 90 m (300 ft)
- Sizes from 80 to 1,800 mm (3 to 72 in.)

Immersible, solids handling pumps

Overhung, single-stage, end suction pumps with non-clog impellers and IP67-rated, totally enclosed, blower-cooled (TEBC) motors; vertical frame mounted (MN Immersible, MF Immersible)

Operating parameters

- Flows to 17,000 m³/h (75,000 gpm)
- Heads to 75 m (250 ft)
- Sizes from 80 to 1,067 mm (3 to 42 in.)

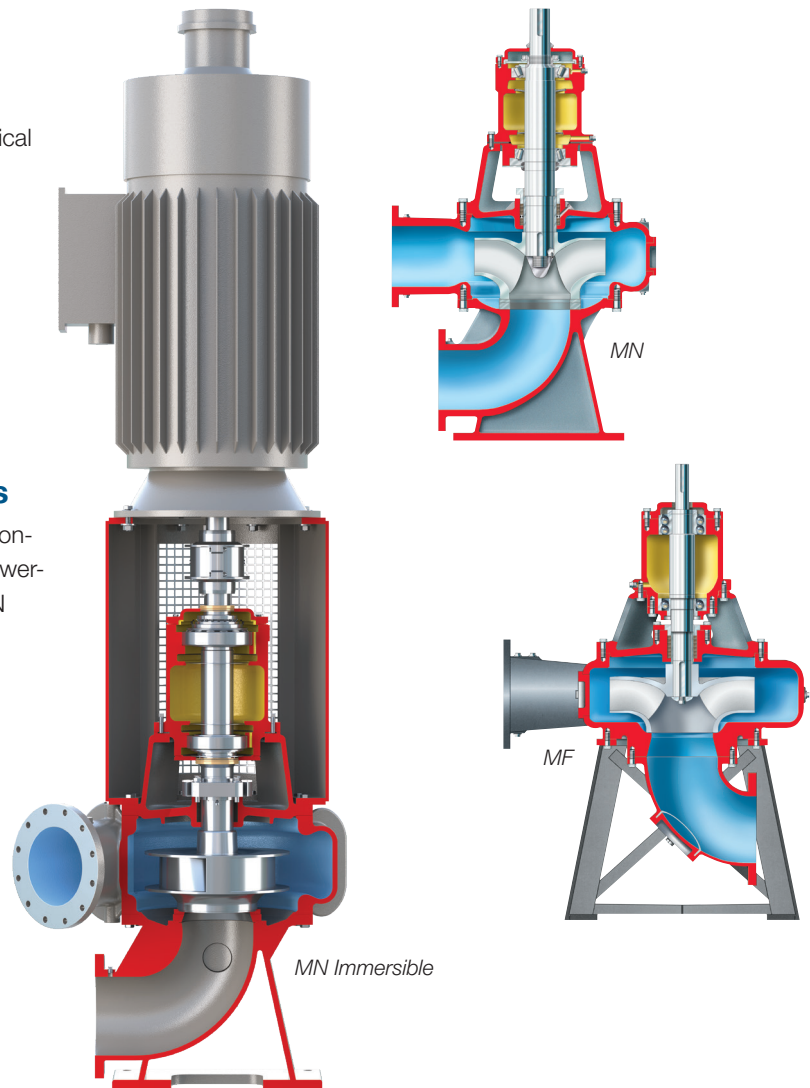



Vertical, solids handling pumps

Single-stage design with above-grade discharge, enclosed impeller and lineshaft (MVX)

Operating parameters

- Flows to 17,000 m³/h (75,000 gpm)
- Heads to 40 m (130 ft)
- Sizes from 250 to 1,200 mm (10 to 48 in.)

Submersible, solids handling pumps

Overhung, single-stage, end suction pump with enclosed impeller; vertically mounted in wet-pit, dry-pit or transportable configuration (MSX)

Operating parameters

- Flows to 4,545 m³/h (20,000 gpm)
- Heads to 90 m (300 ft)
- Sizes from 80 to 500 mm (3 to 20 in.)

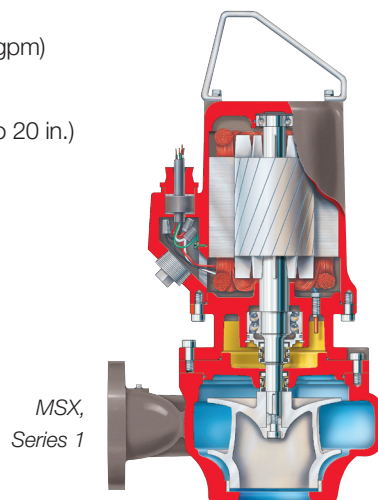
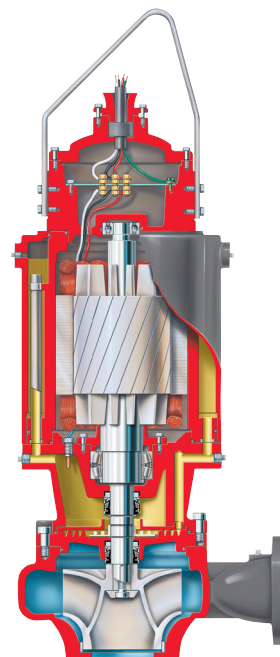
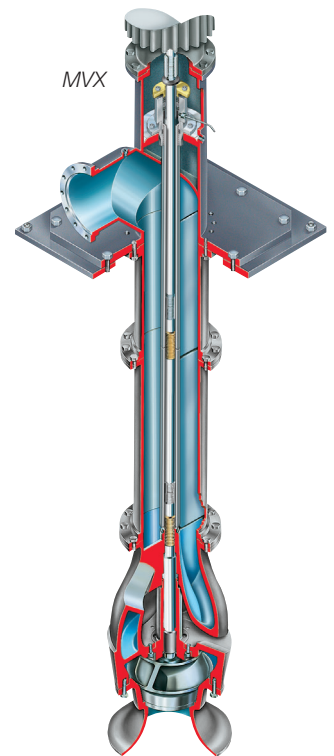



Mechanical seals

Flowserve mechanical seals and sealing systems help our customers cost-effectively meet water quality and environmental regulations and address critical needs, including:

- Low leakage rates
- Improve pump reliability
- Reduce or eliminate process and environmental contamination
- Low-cost but durable designs for stuffing box retrofits
- Maximize interchangeability of components to reduce inventories

We offer many of our seals in NSF/ANSI/CAN 61- and NSF/ANSI/CAN 372-certified versions.

ISC2 seals

Versatile suite of standard cartridge mechanical seals for general service; single and dual configurations available

Pusher design operating parameters

- Pressures to 20.6 bar (300 psi)
- Temperatures from -40°C to 204°C (-40°F to 400°F)
- Sizes from 25 to 200 mm (1.000 to 8.000 in.)

Bellows design operating parameters

- Pressures to 13.8 bar (200 psi)
- Temperatures from -40°C to 204°C (-40°F to 400°F)
- Sizes from 25 to 95 mm (1.000 to 3.750 in.)

QB seals

Highly configurable balanced pusher seal for more severe and/or higher-pressure applications; single and dual configurations available

Operating parameters

- Pressures to 51.7 bar (750 psi)
- Temperatures from -40°C to 204°C (-40°F to 400°F)
- Speeds to 23 m/s (75 fps)
- Sizes from 12.7 to 139.7 mm (0.500 to 5.500 in.)

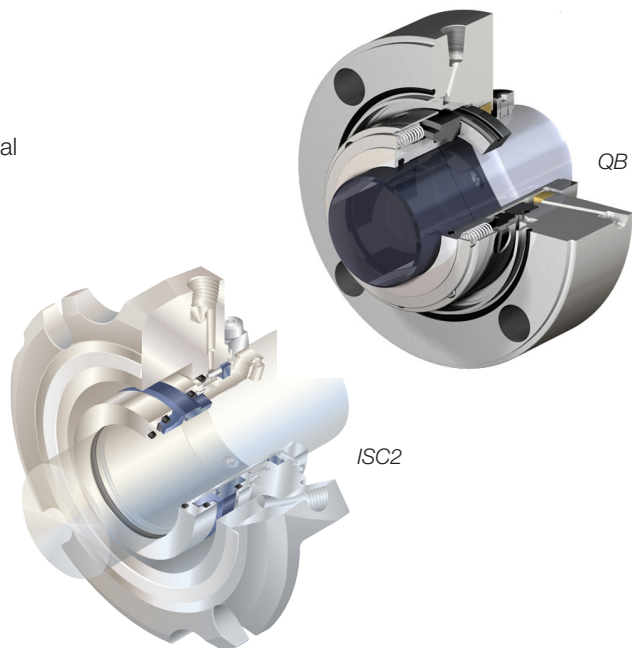

PSS 4 split seals

Semi-cartridge split seal simplifies installation without requiring equipment teardown

Operating parameters

- Pressures from full vacuum to 30 bar (450 psi)
- Temperatures from -18°C to 121°C (0°F to 250°F)
- Speeds up to 19.3 m/s (3,800 fpm)
- Sizes from 38 to 152 mm (1.500 to 6.000 in.)

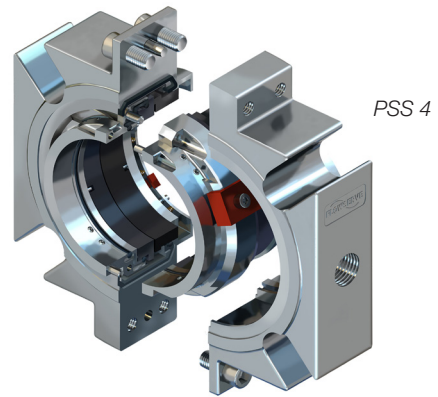

SLM-6000 seal

Single-cartridge seal capable of handling wastewater with solids

Operating parameters

- Pressures to 17.2 bar (250 psi)
- Temperatures from -18°C to 79°C (0°F to 175°F)
- Solids up to 20% by weight
- Sizes from 32 to 235 mm (1.250 to 9.250 in.)

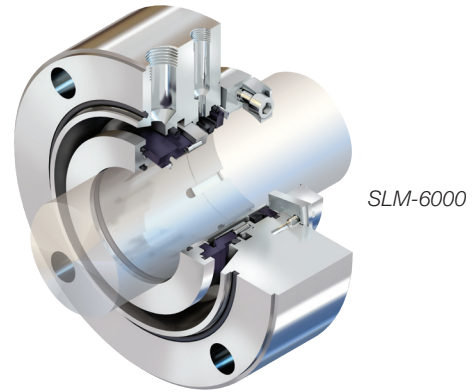

Certified to
NSF/ANSI/CAN 61
& NSF/ANSI/CAN 372

Drinking water quality from source to tap

The ISC2-PX-61, QB-61 and PSS 4-61 models are the NSF/ANSI/CAN 61- and NSF/ANSI/CAN 372-certified versions of the ISC2, PSS 4 and QB seals. These seals satisfy NSF International's rigorous evaluation process for applications that involve drinking water, from source to the tap.

NSF certifications cover all wetted components and demonstrate how these seals meet regulatory requirements for drinking water quality, giving municipalities and water consumers confidence in safe seal selection and operation.





Digitize the entire water value chain

Digitizing water systems helps water providers optimize the performance and operation of aging infrastructure, which aids in their efforts to overcome increasing water scarcity, higher stress on water systems, urbanization and extreme weather.

Advances in digital technologies provide water plant operators a clearer picture of what matters, plus the advantages of monitoring equipment, improving electrical consumption and predicting behaviors across all operations globally.



RedRaven for water processing

Flowserve understands that digitization will be key to making water and wastewater processes more efficient, resilient and sustainable. That's why we designed RedRaven as a complete predictive maintenance solution for water processing and delivery systems.

RedRaven integrates a dense network of sensors, intelligent equipment, real-time data analytics and advanced monitoring. Customers are backed by Flowserve experts who support plant reliability engineers and maintenance personnel with troubleshooting and sound recommendations.

Predictive maintenance: See what matters in real time

Water plant operators can gain the advantage of seeing what matters most — in real time, because RedRaven enables technicians to proactively identify and address equipment issues before they cause costly downtime and disruptions.

Enhanced reliability — Become better prepared for changes in water demand, process conditions and regulatory requirements.

Process excellence — Optimize individual components as well as connected processes across the water and wastewater utility value chain.

Maximized uptime — Avoid unplanned downtime of water plant assets with predictive analytics and condition monitoring.

Reduced costs — Lower energy consumption, minimize maintenance and repairs, and ensure production objectives are achieved on time and within budget; optimize existing assets to avoid capital projects to expand capacity.

Increased affordability — Reduce capital and operating costs to make it possible for water project developers and plant operators to meet agreed-upon rate structures.

Environmental protection — Minimize or avoid contamination of soil, waterways and the atmosphere while also conserving critical water resources.

Success story

UK-based water utility provider saves time and money with predictive maintenance

Challenge

Anglian Water, one of the largest water utility providers in the United Kingdom, faced pressure to improve equipment reliability. They sought an innovative, predictive maintenance approach that would increase reliability and enhance efficiency.

In particular, the utility wanted an accurate, streamlined dashboard to keep its technicians well informed. It needed ongoing support with clear explanations about the status of pumps as well as recommendations for maintenance and actions to improve performance. And the utility required easy integration of monitoring and analytics to complement an existing pump repair agreement between Anglian Water and Flowserve.

Solution

Flowserve recommended our RedRaven predictive maintenance solution. It's a connected platform that gives you the tools and insights to monitor and optimize flow control equipment. RedRaven enables plant operators to proactively identify and address issues before they cause downtime and disruptions.

After a successful one-month trial, Anglian Water deployed RedRaven to 11 pumps at four sites. Since then, the water utility has expanded its use of RedRaven to nearly 900 assets across its clean water and recycled water operations.

RedRaven has enabled Anglian Water to minimize maintenance time and costs. Employees are more productive and effective due to the concise explanation of pump conditions plus the insights provided by RedRaven and our specialists at the Flowserve Monitoring Center.

Anglian Water's leaders continue to be satisfied with the results they've achieved with RedRaven. They recommend RedRaven and Flowserve to other water plant operators who are looking for next-level system performance.





Flowserve Corporation
5215 North O'Connor Blvd.
Suite 700
Irving, Texas 75039-5421 USA

PUBR001097-10 (EN/A4) September 2023
(Formerly FPD-6)

Flowserve Corporation has established industry leadership in the design and manufacture of its products. When properly selected, this Flowserve product is designed to perform its intended function safely during its useful life. However, the purchaser or user of Flowserve products should be aware that Flowserve products might be used in numerous applications under a wide variety of industrial service conditions. Although Flowserve can provide general guidelines, it cannot provide specific data and warnings for all possible applications. The purchaser/user must therefore assume the ultimate responsibility for the proper sizing and selection, installation, operation, and maintenance of Flowserve products. The purchaser/user should read and understand the Installation Instructions included with the product, and train its employees and contractors in the safe use of Flowserve products in connection with the specific application.

While the information and specifications contained in this literature are believed to be accurate, they are supplied for informative purposes only and should not be considered certified or as a guarantee of satisfactory results by reliance thereon. Nothing contained herein is to be construed as a warranty or guarantee, express or implied, regarding any matter with respect to this product. Because Flowserve is continually improving and upgrading its product design, the specifications, dimensions and information contained herein are subject to change without notice. Should any question arise concerning these provisions, the purchaser/user should contact Flowserve Corporation at any one of its worldwide operations or offices.

©2023 Flowserve Corporation. All rights reserved. This document contains registered and unregistered trademarks of Flowserve Corporation. Other company, product, or service names may be trademarks or service marks of their respective companies.