

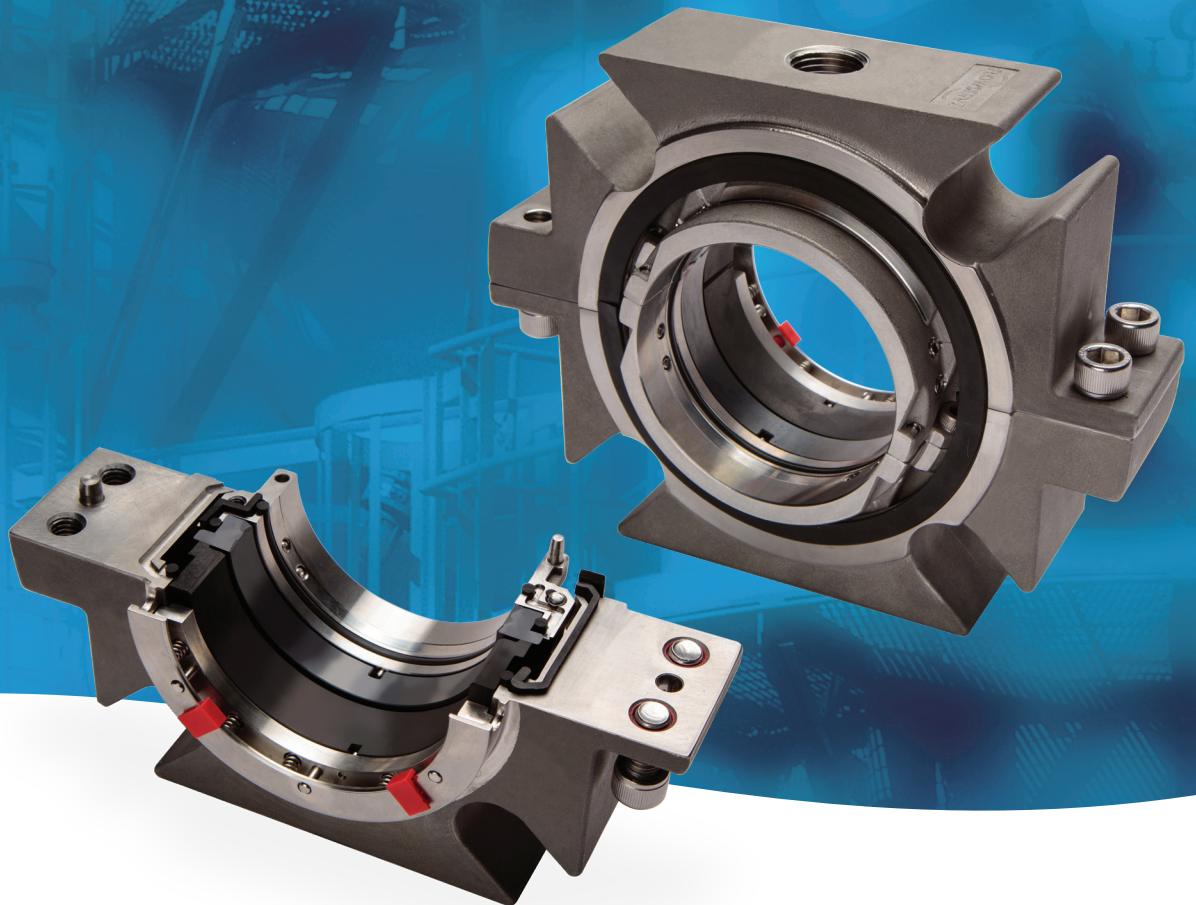

PSS 4 Split Seal

Intrinsic joint alignment technology



Experience In Motion

Simple installation and versatile design

With only two major components, the PSS 4 split seal makes installation quick and easy without requiring equipment teardown. The pre-assembled, semi-cartridge rotating and stationary halves eliminate equipment measurements and handling of small intricate components, including seal faces and gaskets. This innovative design with enhanced pressure capability makes the PSS 4 seal ideal for nearly all industries, including pulp and paper, wastewater treatment, power generation, light chemical and drinking water.

The PSS 4 seal difference

- Fully split design installs around the shaft, outside of the seal chamber, eliminating the need to dismantle the equipment for seal installation.
- Easy installation made even easier with fully pre-assembled, unitized component, semi-cartridge segments.
- All internal gaskets are mechanically held in place, eliminating the need for adhesives.

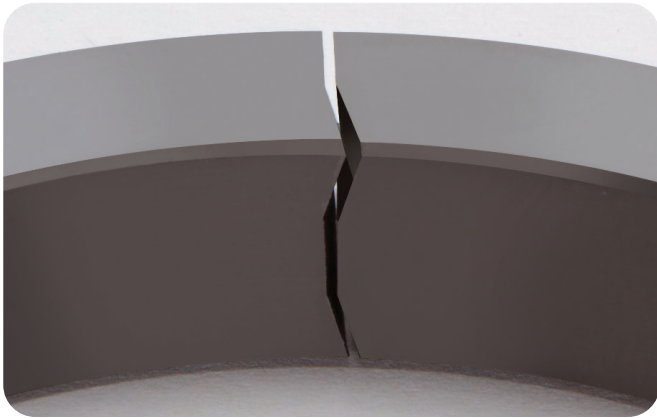

- Exclusive 3D key technology assures optimum seal face alignment in both axial and radial directions, reducing joint leakage and installation time.
- Setting tabs position the rotating face for optimal joint reunion while properly locating the rotor assembly without measuring or marking, assuring first time/every time installation success.

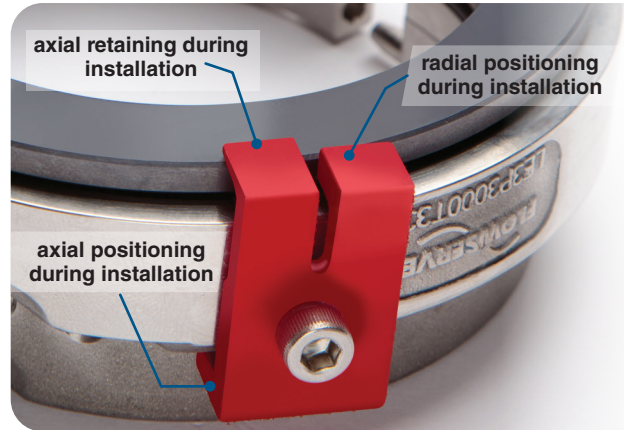

- The positive-drive rotor is held firmly in place by eight set screws, enabling use in higher pressures and fluid viscosities.
- Sealing faces are driven by direct-drive pins, significantly increasing viscous fluid sealing capability over friction-driven faces.
- Easily handles mixer equipment runout up to 1.5 mm (0.060 in.) TIR radial shaft movement, accommodating demanding mixer characteristics.
- All springs and pins are outside of the process fluid, reducing chance of clogging or corrosion.
- Standardized NPT port enables direct flush line installation with standard fittings and wrenches.

NSF/ANSI/CAN 61



PSS 4-61 split seals satisfy NSF International's rigorous evaluation process and are certified to NSF/ANSI/CAN 61 and NSF/ANSI 372 for applications that involve drinking water, from the source to the tap.

NSF certifications cover all wetted components and demonstrate how PSS 4-61 seals meet regulatory requirements for drinking water quality, giving municipalities and water consumers confidence in safe seal selection and operation.

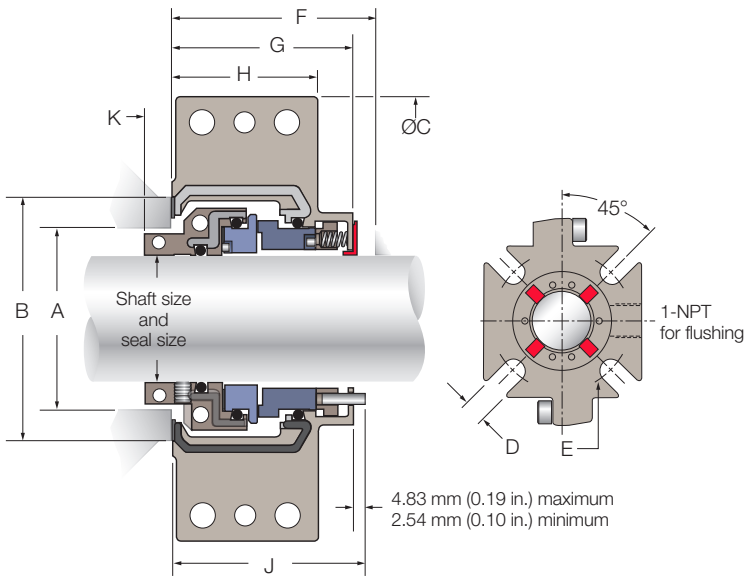

Materials of construction

- Stator Face:** Carbon, silicon carbide
- Rotor Face:** Silicon carbide, aluminum oxide
- Metal Parts:** 316 stainless steel
- Springs:** Alloy C-276
- Secondary Seals:** FKM, EPDM

Standard operating limits

- Pressure:** Full vacuum to 30 bar (450 psi)
- Temperature:** -18°C to 121°C (0°F to 250°F)
- Speed:** 19.3 m/s (3,800 fpm)
- Sizes:** 38 to 152 mm (1.500 to 6.000 in.)
For larger sizes, use the PSSL.

Dimensional data (mm)

Shaft and Seal Size +0.025 to -0.050	A	C	D	E	E	F	K
	Seal Chamber Bore		Max. Bolt Size	Min. Bolt Circle	Max. Bolt Circle	Min. DFO	
40	57.2 to 66.6	139.7	12.7	91.9	120.7	63.5	8.4
45	60.5 to 69.9	137.4	12.7	95.3	110.7	63.5	8.4
50	66.6 to 76.2	146.1	12.7	102.4	128.5	63.5	8.4
55	73.2 to 85.9	147.6	15.9	115.8	143.3	69.1	9.9
60	76.2 to 88.9	150.9	15.9	119.1	128.5	69.1	9.9
65	82.6 to 95.3	157.2	15.9	125.5	152.4	69.1	9.9
70	85.9 to 98.6	171.5	15.9	128.5	156.7	69.1	9.9
75	92.0 to 104.7	193.5	19.1	141.2	168.4	69.1	9.9
80	98.6 to 111.3	182.6	19.1	144.5	168.4	69.1	9.9
85	101.6 to 114.3	185.7	19.1	147.6	169.9	69.1	9.9
90	111.3 to 130.3	203.2	19.1	165.1	187.2	77.7	13.0
95	114.3 to 133.4	222.3	19.1	168.4	198.9	77.7	13.0
100	120.7 to 139.7	228.6	22.2	177.8	201.2	77.7	13.0
105	124.0 to 143.0	228.6	22.2	184.2	209.6	77.7	14.5
120	139.7 to 158.8	235.2	22.2	196.9	216.2	77.7	18.3
140	158.8 to 190.5	292.1	22.2	228.6	273.1	77.7	23.9

Dimensional data (in.)

Shaft and Seal Size +0.001 to -0.002	A	C	D	E	E	F	K
	Seal Chamber Bore		Max. Bolt Size	Min. Bolt Circle	Max. Bolt Circle	Min. DFO	
1.500	2.12 to 2.50	5.25	0.500	3.50	4.33	2.50	0.33
1.625	2.25 to 2.62	5.50	0.500	3.62	4.75	2.50	0.33
1.750	2.38 to 2.75	5.41	0.500	3.75	4.36	2.50	0.33
1.875	2.50 to 2.88	5.53	0.500	3.88	4.67	2.50	0.33
2.000	2.62 to 3.00	5.75	0.500	4.03	5.06	2.50	0.33
2.125	2.75 to 3.25	5.69	0.625	4.44	5.38	2.72	0.39
2.250	2.88 to 3.38	5.81	0.625	4.56	5.64	2.72	0.39
2.375	3.00 to 3.50	5.94	0.625	4.69	5.06	2.72	0.39
2.500	3.12 to 3.75	6.88	0.625	5.00	6.20	2.72	0.39
2.625	3.25 to 3.75	6.19	0.625	4.94	6.00	2.72	0.39
2.750	3.38 to 3.88	6.75	0.625	5.06	6.17	2.72	0.39
2.875	3.50 to 4.00	6.44	0.625	5.19	5.94	2.72	0.39
3.000	3.62 to 4.12	7.62	0.750	5.56	6.63	2.72	0.39
3.125	3.75 to 4.25	7.06	0.750	5.56	6.44	2.72	0.39
3.250	3.88 to 4.38	7.19	0.750	5.69	6.63	2.72	0.39
3.375	4.00 to 4.50	7.31	0.750	5.81	6.69	2.72	0.39
3.500	4.25 to 5.00	8.50	0.750	6.38	7.45	3.06	0.51
3.625	4.38 to 5.13	8.00	0.750	6.50	7.37	3.06	0.51
3.750	4.50 to 5.25	8.75	0.750	6.63	7.83	3.06	0.51
3.875	4.63 to 5.38	8.25	0.750	6.75	7.63	3.06	0.51
4.000	4.75 to 5.50	9.00	0.875	7.00	7.92	3.06	0.51
4.125	4.88 to 5.63	8.88	0.875	7.13	8.13	3.06	0.53
4.250	5.00 to 5.75	9.00	0.875	7.25	8.25	3.06	0.57
4.375	5.13 to 5.88	9.13	0.875	7.38	8.38	3.06	0.60
4.500	5.25 to 6.00	9.25	0.875	7.50	8.50	3.06	0.64
4.625	5.38 to 6.13	9.38	0.875	7.63	8.63	3.06	0.68
4.750	5.50 to 6.25	9.26	0.875	7.75	8.51	3.06	0.72
4.875	5.63 to 6.38	9.63	0.875	7.88	8.88	3.06	0.75
5.000	5.75 to 7.00	10.65	0.875	8.50	10.00	3.06	0.79
5.125	5.88 to 7.13	10.38	0.875	8.63	9.63	3.06	0.83
5.250	6.00 to 7.25	10.50	0.875	8.75	9.75	3.06	0.87
5.375	6.13 to 7.38	10.63	0.875	8.88	9.88	3.06	0.90
5.500	6.25 to 7.50	11.50	0.875	9.00	10.75	3.06	0.94
5.625	6.38 to 7.63	10.88	0.875	9.13	10.13	3.06	0.98
5.750	6.50 to 7.75	11.00	0.875	9.25	10.25	3.06	1.02
5.875	6.63 to 7.88	11.13	0.875	9.38	10.38	3.06	1.05
6.000	6.75 to 8.00	11.25	0.875	9.50	11.25	3.06	1.09

Other sizes available on request. Contact Flowserve Engineering for more information.

The PSS 4 split seal provides the easiest and most successful installation routine to make reduced equipment downtime and increased reliability ... routine.

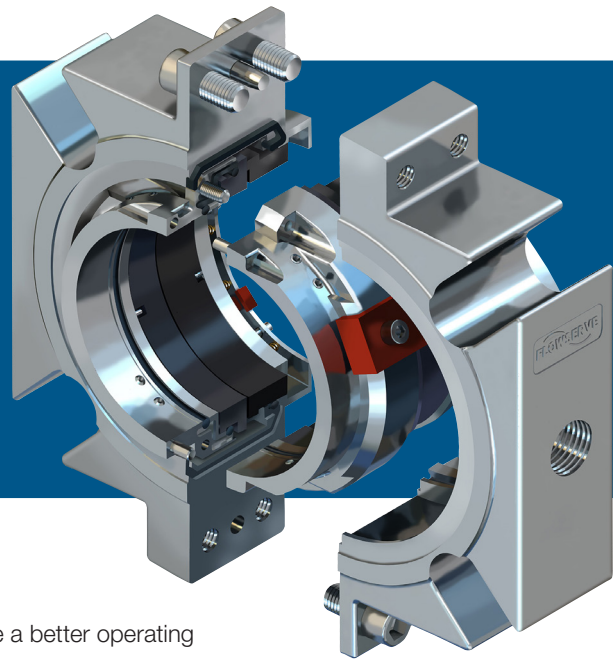

Related accessories

The following accessories are often used with PSS 4 seals to provide a better operating environment for the seal while reducing flush water usage.



Seal Gard™

Dependable flow control saves water costs and reduces seal water. Seal Gard flow meters are effective at controlling the environment around single and dual mechanical seals.

Clear-view flow meter has a vertical, tapered, acrylic flow tube that resists fouling. Various sizes and features are available to properly establish the correct seal flush flow rate. In paper stock service, the Seal Gard is the ideal sealing system for a PSS 4 split seal and split flow reducer or solids excluder bushing.

Split flow reducer

An engineered, close-clearance device that lowers seal water flush (Plan 32) requirements when used with a Flowserve seal. Split axially for easy installation and constructed of glass-filled PTFE for corrosion and abrasion resistance.

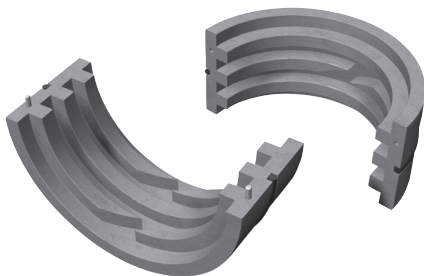

SEB (solids excluder bushing)

The SEB reduces the amount of flush required and clears solids from the seal chamber. This provides a cleaner operating environment that helps reduce operating costs and improves mean time between planned maintenance (MTBPM).