

Remove heat and reduce flush fluid temperature with the NX Seal Cooler to enhance mechanical seal reliability in chemical and general industrial services.

NX Seal Coolers are compact and efficient shell and tube systems designed for simplicity and low maintenance. Process or barrier fluid passes through the tube while cooling water passes through the shell, providing effective heat transfer while minimizing scaling and fouling.

Features and benefits

- Compact design with integral mounting bracket and convenient pipe porting for easy installation in limited space
- Easy access to coil for cleaning with only one bolt fastening the shell
- Vertical or horizontal mounting based on application conditions and orientation constraints
- High-temperature fittings included as standard
- Designed in accordance with ASME Section VIII-1 and PED



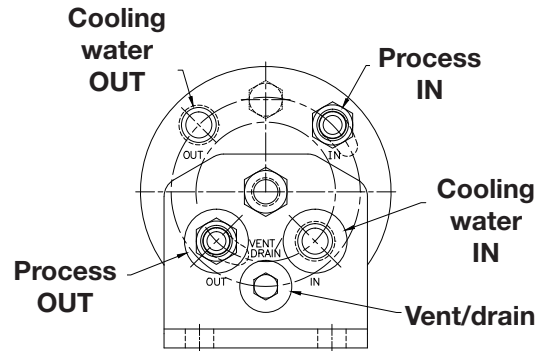
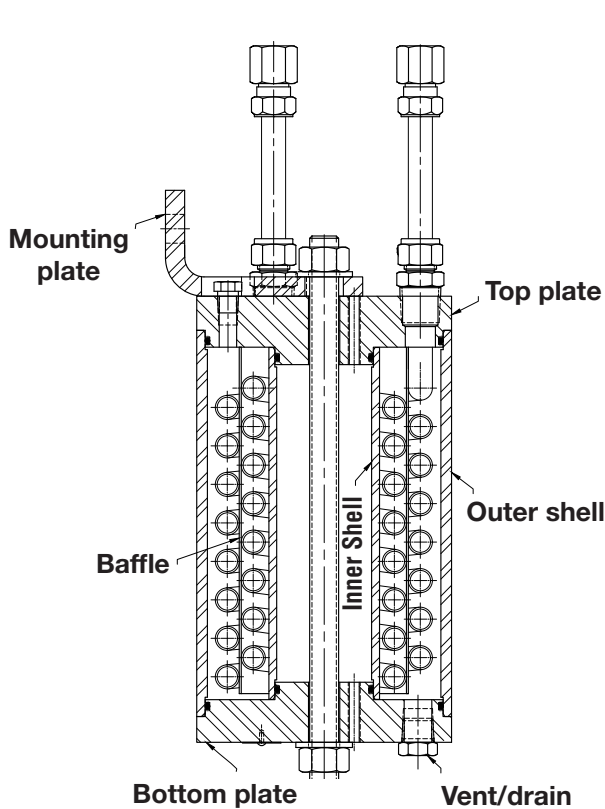

Materials of construction

O-rings	Fluoroelastomer
Tubing	304 stainless steel
Fittings	316 stainless steel
Shells and plates	Carbon steel (painted)

Model numbers

Tube OD	0.500 in	0.625 in	0.750 in
Standard	NX0500SA	NX0625SA	NX0750SA
PED			NX0750SA-P

Technical details

	English units			SI units		
	0.500 in	0.625 in	0.750 in	13 mm	16 mm	19 mm
Tube OD	0.500 in	0.625 in	0.750 in	13 mm	16 mm	19 mm
Effective cooling area	1.75 ft ²	3.5 ft ²	5.8 ft ²	0.16 m ²	0.33 m ²	0.54 m ²
Weight	46 lb	55 lb	121 lb	21 kg	25 kg	55 kg
Max. temperature – tube side	800°F	800°F	800°F	427°C	427°C	427°C
Max. temperature – shell side	212°F	212°F	212°F	100°C	100°C	100°C
Max. pressure – tube side	1600 psig	1200 psig	1350 psig	11 000 KPa	8300 KPa	9300 KPa
Max. pressure – shell side	150 psig	150 psig	150 psig	1035 KPa	1035 KPa	1035 KPa

FSD174a (E/A4) May 2019

Headquarters

Flowserve Corporation
5215 North O'Connor Blvd.
Suite 2300
Irving, Texas 75039-5421 USA
Telephone: +1 937 890 5839

USA and Canada

Kalamazoo, Michigan USA
Telephone: +1 269 381 2650

Europe, Middle East, Africa

Etten-Leur, The Netherlands
Telephone: +31 765 028 200

Asia Pacific

Singapore
Telephone: +65 6544 6800

Latin America

Mexico City
Telephone: +52 55 5567 7170

Flowserve Corporation has established industry leadership in the design and manufacture of its products. When properly selected, this Flowserve product is designed to perform its intended function safely during its useful life. However, the purchaser or user of Flowserve products should be aware that Flowserve products might be used in numerous applications under a wide variety of industrial service conditions. Although Flowserve can provide general guidelines, it cannot provide specific data and warnings for all possible applications. The purchaser/user must therefore assume the ultimate responsibility for the proper sizing and selection, installation, operation, and maintenance of Flowserve products. The purchaser/user should read and understand the Installation Instructions included with the product, and train its employees and contractors in the safe use of Flowserve products in connection with the specific application.

While the information and specifications contained in this literature are believed to be accurate, they are supplied for informative purposes only and should not be considered certified or as a guarantee of satisfactory results by reliance thereon. Nothing contained herein is to be construed as a warranty or guarantee, express or implied, regarding any matter with respect to this product. Because Flowserve is continually improving and upgrading its product design, the specifications, dimensions and information contained herein are subject to change without notice. Should any question arise concerning these provisions, the purchaser/user should contact Flowserve Corporation at any one of its worldwide operations or offices.

©2019 Flowserve Corporation. All rights reserved. This document contains registered and unregistered trademarks of Flowserve Corporation. Other company, product, or service names may be trademarks or service marks of their respective companies.