

# **Byron Jackson<sup>®</sup> H2O+ Standard Submersible Motors**

304 stainless steel three-phase motors for  
long-lasting, deep well performance





## Highly reliable and long-lasting deep well performance

Byron Jackson H2O+ standard submersible pumps and motors offer an extraordinary range of performance and feature proprietary hydraulics along with precision cast bowls and impellers as well as enhanced cooling properties to ensure long life and efficient operation. In addition, they meet drinking water regulations:

- NSF/ANSI 61 and 372 certified
- WRAS and ACS approved

### High-quality, stainless steel construction

H2O+ water-filled standard motors are constructed of 304 stainless steel as standard with PE2+PA insulated winding wire for superior performance in well water up to 50°C (122°F). The stators are rewindable, and the winding system is well-suited for variable frequency drive (VFD) operation.

### Quick delivery when you need it

Farmers, golf course superintendents, municipalities, and industrial and mining maintenance managers depend on reliable pumping equipment for their daily processes and quick replacement when a failure occurs. Byron Jackson H2O+ submersible pumps and motors are stocked strategically for quick delivery so you can keep your processes running profitably. Pumps in standard sizes and materials can be assembled to order from stocked components and shipped in one to four weeks.



### Broad submersible pump portfolio

Flowserve offers one of the broadest ranges of deep well submersible pumps in the world. Along with extensive hydraulic coverage, Byron Jackson pumps offer oil-filled or water-filled submersible motors, enabling you to specify the pumping system that best meets your application, specification and lifecycle cost requirements.

## Extended motor and pump life plus reduced total costs

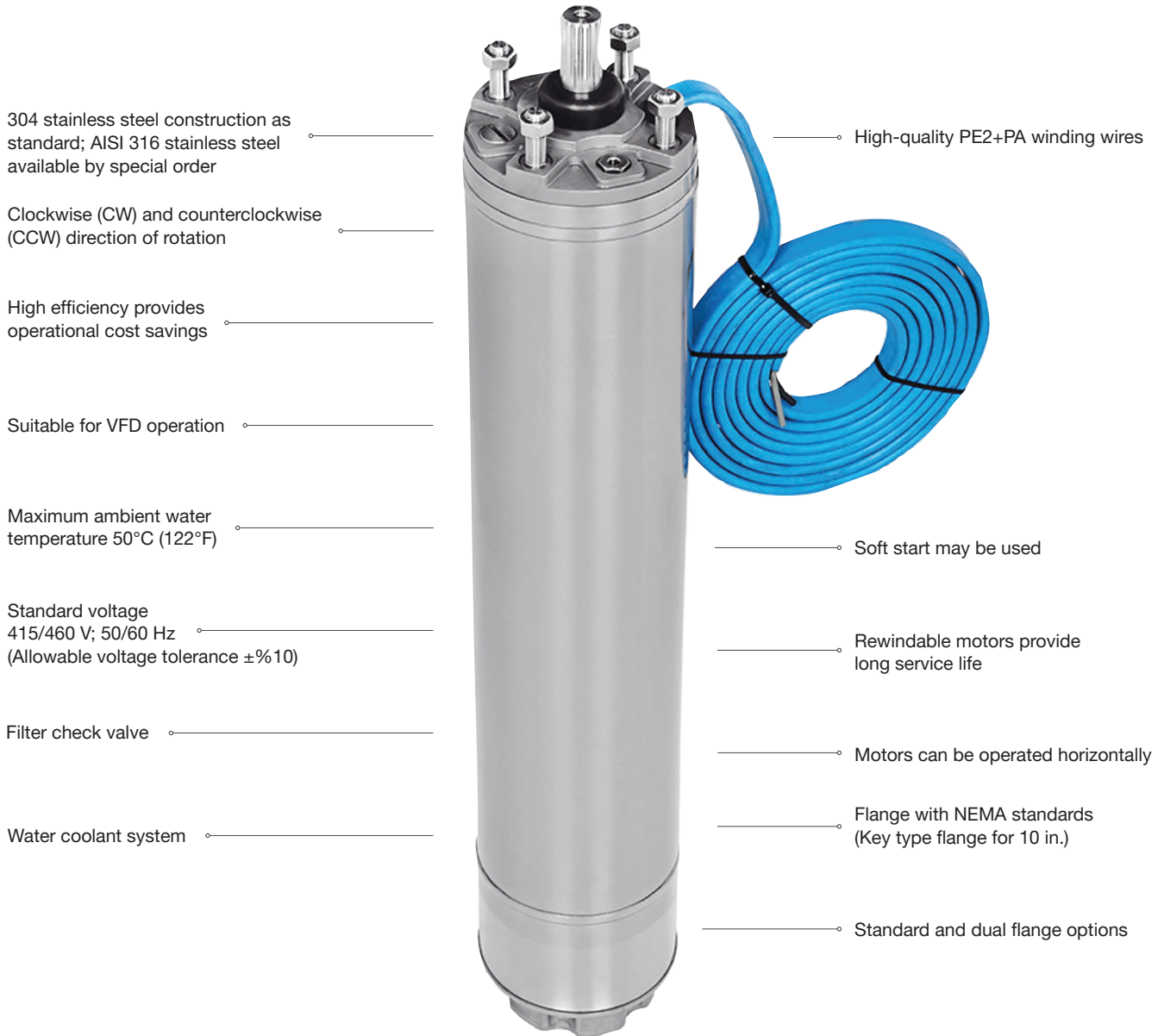

304 stainless steel construction as standard; AISI 316 stainless steel available by special order

Clockwise (CW) and counterclockwise (CCW) direction of rotation

High efficiency provides operational cost savings

Suitable for VFD operation

Maximum ambient water temperature 50°C (122°F)

Standard voltage 415/460 V; 50/60 Hz (Allowable voltage tolerance  $\pm 10\%$ )

Filter check valve

Water coolant system

High-quality PE2+PA winding wires

Soft start may be used

Rewindable motors provide long service life

Motors can be operated horizontally

Flange with NEMA standards (Key type flange for 10 in.)

Standard and dual flange options

### Target applications

Excellent choice for submersible motor applications, including:

- Water wells (domestic, agricultural, municipal)
- Fountains
- Mining and industrial
- Drinking water applications

### Drinking water safe

Meets drinking water regulations, including:

- NSF/ANSI 61 and 372
- WRAS (UK)
- ACS (France)

## Designed and built for extraordinary performance



### PT100 overheating protection

A PT100 is available as an option but is not supplied as a standard feature. Contact factory for price adder and lead time.



### Up-thrust ring

Provides safe operating conditions for motor by absorbing up-thrust loads.

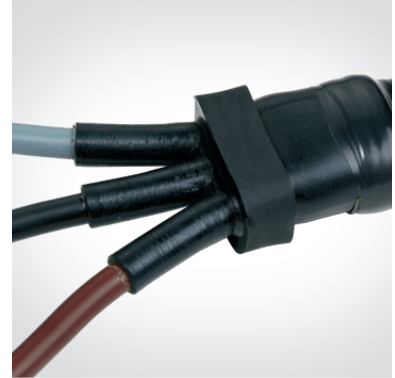

### Cable connection

Preventing the water inside the motor to run through the cable and reach connection parts of power cables by specially designed cable seals.



### Adjustment screw

Standard shaft height can be precisely adjusted by the adjustment screw on the thrust bearing base.



### Membrane

Membrane minimizes the expansion pressure that is caused by heating of cooling water inside the motor.



### Sand guard

Sand guard extends the life of the mechanical seal in applications where there are heavy particulates in the well water.



**Heavy-duty bearings with high thrust capacity**

Heavy-duty thrust bearings are bi-directional and carry high thrust loads.



**Water-lubricated radial carbon bearings**

Radial carbon bearings are grooved for greater lubrication and provide excellent support for the rotor shaft.

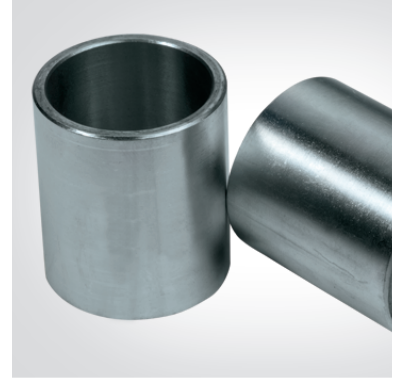

**Chrome-plated bearing sleeves**

Precisely machined chrome-plated bearing sleeves provide long life and low friction at the radial bearing journals.

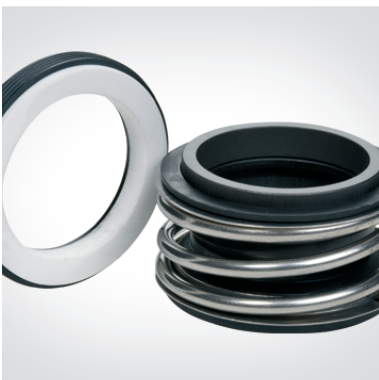

**Mechanical sealing for high sand resistance (IP68)**

The motors are fitted with a SiC-SiC heavy-duty mechanical seal for extended seal life.



**Motor lead end (MLE)**

Connection of the MLE to the top case is made by the cable seal and cable seal cover.



**Pressure-balancing check valve**

Check valve controls pressure changes within the motor. As pressure increases, the valve opens to relieve pressure to prevent damage of lower membrane. When the pressure drops, the valve filters well water and allows it back into the motor.

## Industry-leading reliability and safety

H2O+ submersible motors deliver reliable performance at temperatures up to 50°C (122°F) — while ensuring trouble-free operation and a long service life.

The design provides high resistance against voltage fluctuation and a safety factor that's better than standard motors.

H2O+ submersible motors come with PE2+PA winding wire as standard: the highest grade available for comparable motors.

It consists of a single copper conductor and is suitable for use with a variable-speed drive (VFD). PE2 (polyethylene) provides electrical isolation while the PA (polyamide) provides mechanical protection. Increased heat resistance is achieved by cross-linking of polyethylene.



### Technical data

Parameter	PE2+PA winding wire
<b>Tensile strength</b> (at 23°C ±5, per IEC 60811-1-1)	≥ 10 N/mm <sup>2</sup>
<b>Elongation</b> (at 23°C ±5, per IEC 60811-1-1)	≥ %100
<b>Dielectric constant</b> (at 20°C ±5 and 800 Hz, per DIN 53483)	2.3
<b>Specific insulation resistance</b> (at 20°C ±5, per IEC 60093)	10 Ω cm
<b>Dielectric breakdown strength</b> (at 20°C ±5 and 50 Hz, per DIN VDE 0303-21)	70 kV/mm
<b>Tensile strength after aging</b> (at 80°C for 7x24 hours)	≥ 10 N/mm <sup>2</sup>
<b>Elongation at break after aging</b> (at 80°C for 7x24 hours)	≥ %100

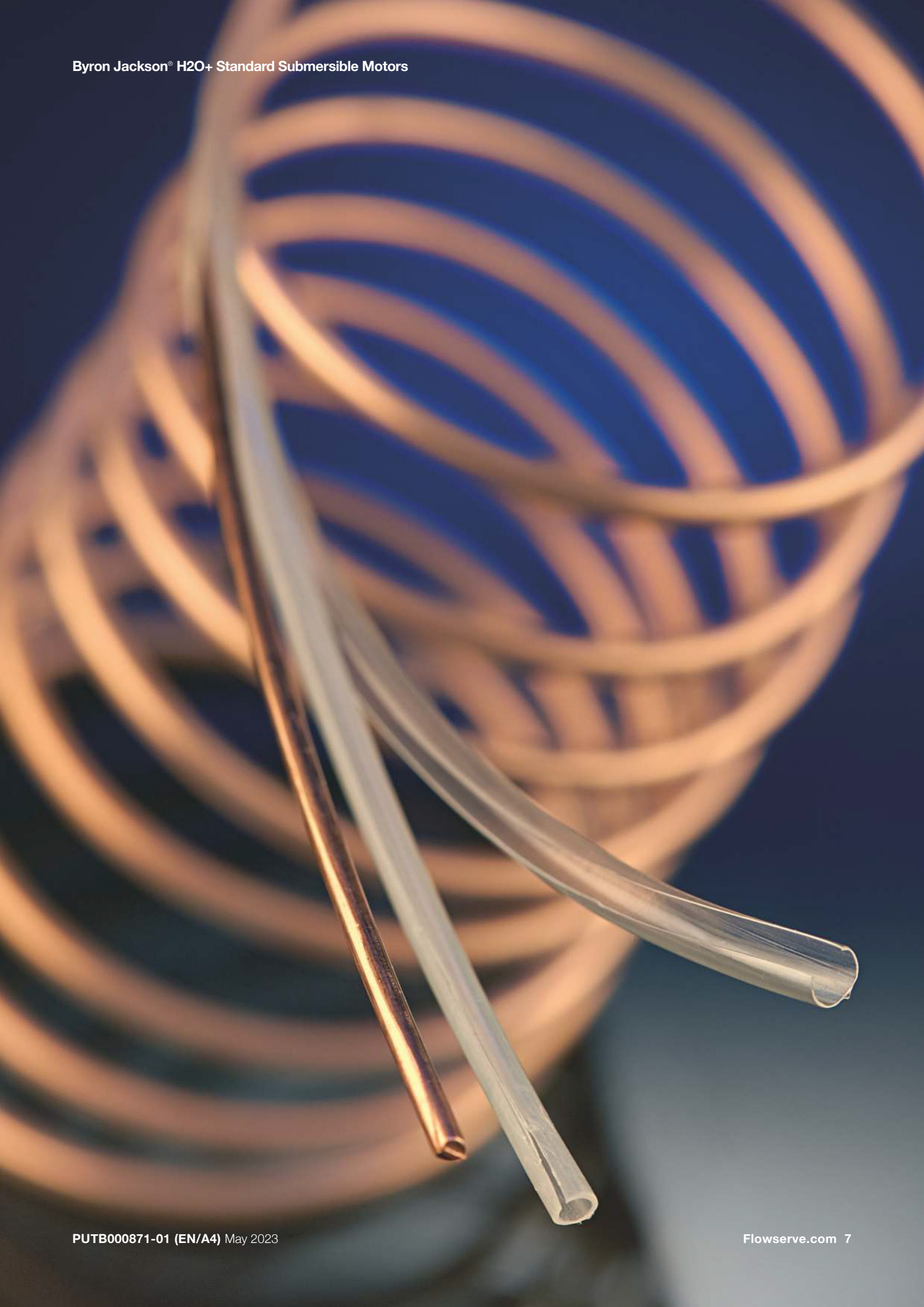

# Parts list and materials of construction

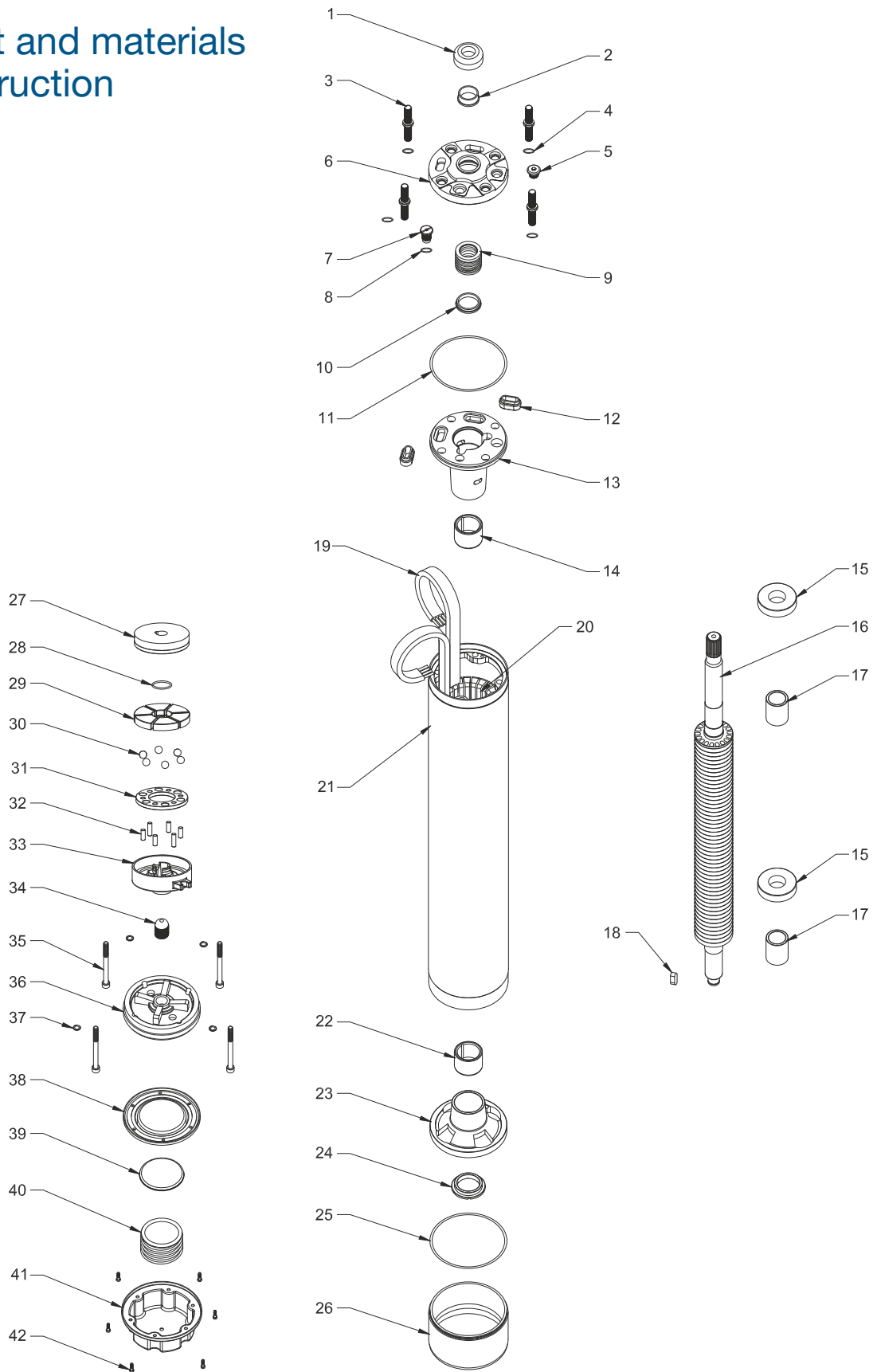



**Byron Jackson® H2O+ Standard Submersible Motors**

Number	Part name	Material
1	Sand guard	NBR_EPDM
2	Inner ring	Bronze
3	Stud	AISI 304
4	O-ring	NBR
5	Plug	AISI 304
6	Upper connection flange	AISI 304
7	Check valve	AISI 304
8	O-ring	NBR
9	Mechanical seal	SiC-SiC
10	Support ring	Bronze
11	O-ring	NBR
12	Cable seal	NBR
13	Upper bearing body	GG25
14	Radial bearing	Carbon
15	Balance ring	CK 45
16	Rotor	-
17	Shaft sleeve	St 37 (Coated CrNi )
18	Key	AISI 420
19	MLE	PVC
20	Stator stack	M530/Magnetic steel
21	Stator	AISI 304
22	Radial bearing	Carbon
23	Lower bearing body	GG25
24	Up-thrust bearing	Bronze
25	O-ring	NBR
26	Axial bearing sheet	AISI 304
27	Thrust disc	Carbon with antimony
28	O-ring	NBR
29	Axial thrust segments	AISI 420
30	Ball	Inox
31	Ball holder	St 37 (Coated Cr+3 )
32	Pins	Inox
33	Axial thrust bearing support	GG25
34	Screw	Inox
35	Bolt	AISI 304
36	Axial bearing body flange	GG25
37	Copper ring	Copper
38	Membrane	NBR
39	Support sheet	AISI 304
40	Spring	AISI 304
41	Membrane cover	AISI 304
42	Bolt	AISI 304

## Power cable information

### Direct on line (DOL)

Maximum allowable power cable length (m) per power cable design, at 50°C											
Number of conductors x size in mm <sup>2</sup>											
3x1.5	3x2.5	3x4	3x6	3x10	3x16	3x25	3x35	3x50	3x70	3x95	3x120
Number of conductors x size in AWG											
3x16	3x14	3x12	3x10	3x8	3x6	3x4	3x2	3x1	3x2/0	3x3/0	3x4/0
65	108	172	258	431	689						
48	80	129	193	322	515						
38	64	102	153	256	409	639					
	52	83	125	209	334	522	730				
	45	72	109	181	289	452	633				
		61	92	153	245	383	536	765			
		52	79	131	210	327	458	655			
				106	170	266	372	531	744		
				90	145	226	316	452	633		
				76	122	190	266	380	532	722	
				67	107	168	235	336	470	638	
					89	139	195	279	390	529	
						115	160	229	321	434	548
							139	198	278	377	476
							131	187	262	356	450
							120	172	241	326	411
								154	215	292	368
								132	192	261	329
								127	178	242	305
									157	213	269
									145	197	249
										182	230
										155	196
											171

MLE cable — 50/60 Hz — 415/460 V cables

Type	Size, in.	Power		DOL, mm <sup>2</sup>	Wye-Delta, mm <sup>2</sup>	Axial thrust, kN	Starts per hour	Length, m
		kW	hp					
MV-6-5.5-2	6	4	5.5	4x2.5	4x2.5 - 3x2.5	20	20	4
MV-6-7.5-2	6	5.5	7.5	4x2.5	4x2.5 - 3x2.5	20	20	4
MV-6-10-2	6	7.5	10	4x2.5	4x2.5 - 3x2.5	20	20	4
MV-6-12.5-2	6	9.3	12.5	4x2.5	4x2.5 - 3x2.5	20	20	4
MV-6-15-2	6	11	15	4x4	4x2.5 - 3x2.5	20	20	4
MV-6-17.5-2	6	13	17.5	4x4	4x2.5 - 3x2.5	20	20	4
MV-6-20-2	6	15	20	4x4	4x2.5 - 3x2.5	20	20	4
MV-6-25-2	6	18.5	25	4x6	4x4 - 3x4	20	20	4
MV-6-30-2	6	22	30	4x6	4x4 - 3x4	20	20	4
MV-6-35-2	6	26.5	35	4x10	4x6 - 3x6	26.5	15	4
MV-6-40-2	6	30	40	4x10	4x6 - 3x6	26.5	15	4
MV-6-50-2	6	37	50	3x16	4x10 - 3x10	26.5	15	4
MV-6-60-2	6	45	60	3x16	4x10 - 3x10	26.5	15	4
MV-8-40-2	8	30	40	4x16	4x10 - 3x10	45	15	4
MV-8-50-2	8	37	50	4x16	4x10 - 3x10	45	15	4
MV-8-60-2	8	45	60	4x16	4x10 - 3x10	45	15	4
MV-8-70-2	8	52	70	4x16	4x10 - 3x10	45	15	4
MV-8-75-2	8	55	75	4x16	4x10 - 3x10	45	15	4
MV-8-80-2	8	60	80	4x16	4x10 - 3x10	45	15	4
MV-8-90-2	8	67	90	4x16	4x10 - 3x10	45	15	4
MV-8-100-2	8	75	100	3x25	4x16 - 3x16	45	15	4
MV-8-110-2	8	81	110	3x25	4x16 - 3x16	55	15	4
MV-8-125-2	8	92	125	3x25	4x16 - 3x16	55	10	4
MV-8-150-2	8	110	150	3x35	3x25 - 3x25	55	10	4
MV-10-110-2	10	81	110	3x25	4x16 - 3x16	75	10	5
MV-10-125-2	10	92	125	3x25	4x16 - 3x16	75	10	5
MV-10-150-2	10	110	150	3x35	3x25 - 3x25	75	10	5
MV-10-175-2	10	129	175	3x35	3x25 - 3x25	75	10	5
MV-10-200-2	10	147	200	3x35	3x25 - 3x25	75	10	5
MV-10-225-2	10	166	225	3x35 - 3x35*	3x35 - 3x35	75	10	5
MV-10-250-2	10	185	250	3x35 - 3x35*	3x35 - 3x35	75	10	5
MV-10-300-2	10	220	300	3x35 - 3x35*	3x35 - 3x35	75	10	5

\* MLE cables for these sizes indicate Wye-Delta wiring. See IOM for how to convert to DOL.

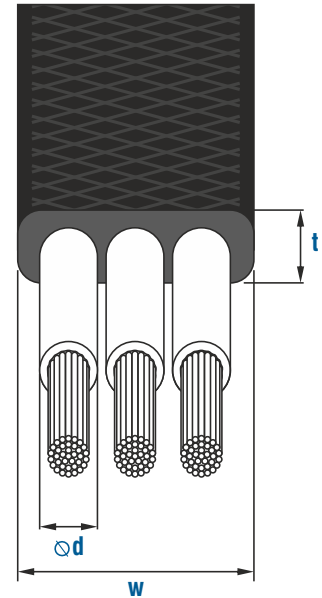

MLE cable dimensions

Type, mm	Thickness (t), mm	Width (w), mm	Diameter (d), mm
3x2.5	6.4±0.2	15.0±0.3	3.6
3x4	7.1±0.5	16.5±0.5	4.1
3x6	8.0±0.5	18.3±0.5	4.6
3x10	8.8±0.5	21.8±0.5	6
3x16	10.5±0.5	25.4±0.5	7
3x25	12.0±0.5	33.0±0.5	9
3x35	13.5±1.0	34.5±1.0	10.1
4x2.5	6.4±0.2	18.0±0.3	3.6
4x4	7.1±0.5	20.2±0.5	4.1
4x6	8.0±0.5	22.4±0.5	4.6
4x10	8.8±0.5	28.0±0.5	6
4x16	10.5±0.5	33.7±0.5	7

## Power cable information

### Connection diagram

#### DOL connection

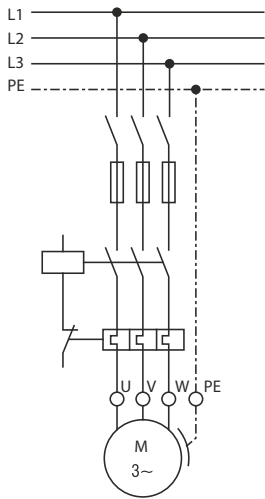

#### Y/Δ connection

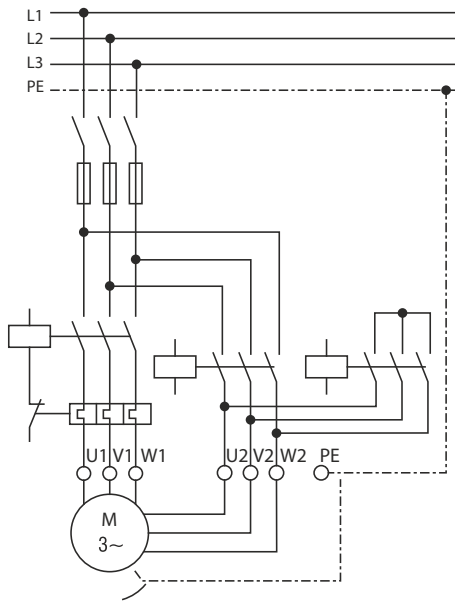

### Power cable splice

Splicing the MLE to the drop cable must be done by an experienced professional to avoid short circuit when installed.

The insulation of each wire should be stripped only as far as necessary to provide room for the barrel connector. Each splice should be taped with appropriate electrical tape using two half-lapped layers wrapped tightly to eliminate air spaces as much as possible.

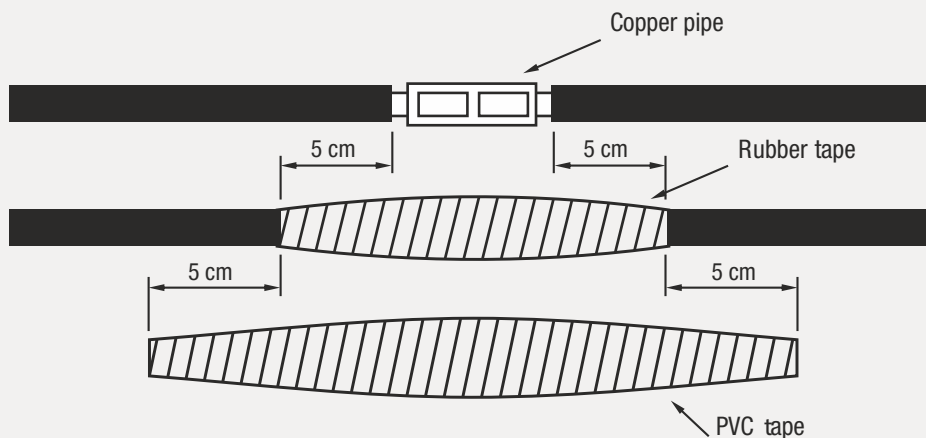

## Connection size

### Standard flange dimensions, mm

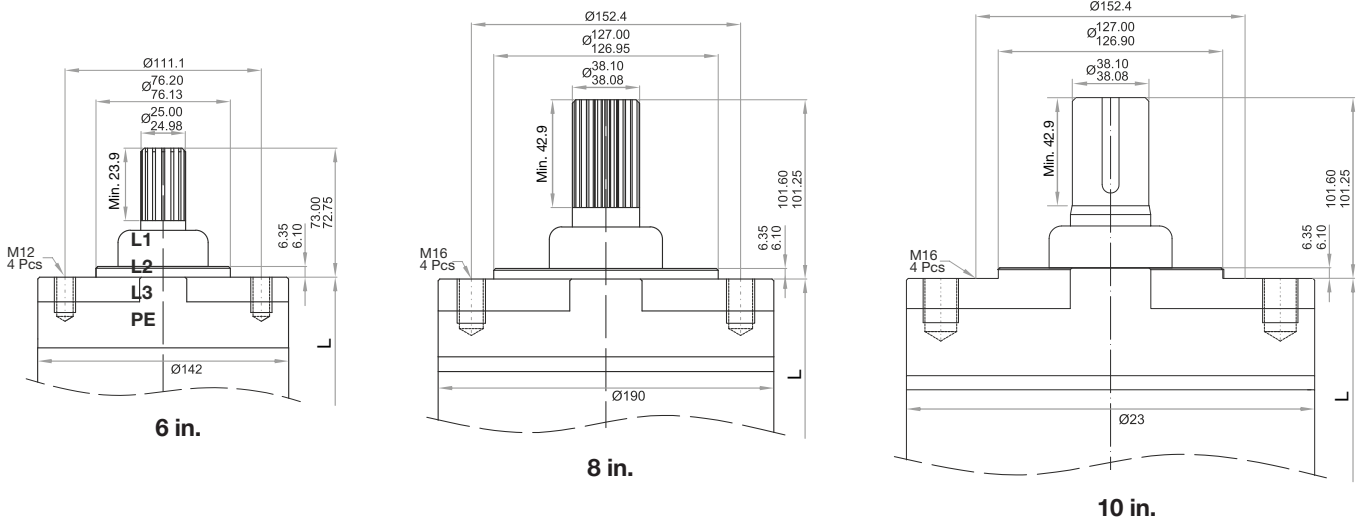

### Optional double flange dimensions, mm

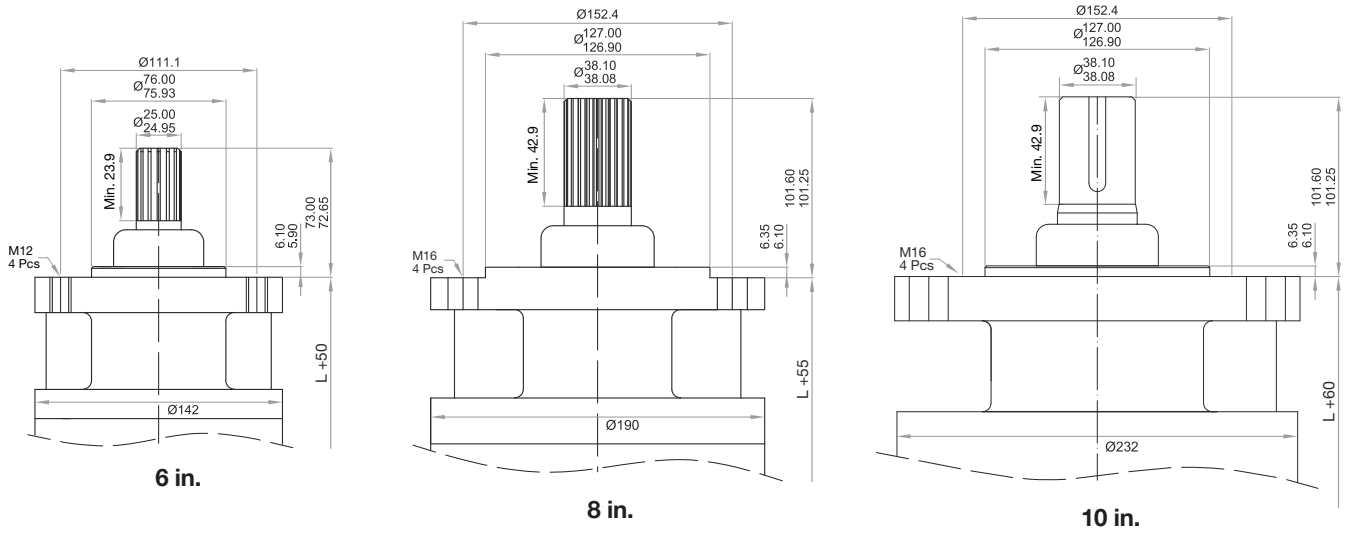

# Motor data

## MV6: 6 in. at 50 Hz

Model	Power		Axial load, kN	Voltage, V	Speed n <sub>N</sub> , rpm	I <sub>N</sub> , A	I <sub>A</sub> , A	Motor efficiency at % load, %			Power factor (φ) at % load, %			Length, mm	Weight, kg
	hp	kW						@50%	@75%	@100%	@50%	@75%	@100%		
MV6-5.5-2*	5.5	4	20	380	2,770	10.2	39.4	67	71	71	63	71	84	594	38
				400	2,785	9.8	37.8	68	72	72	59	67	82		
				415	2,795	9.5	36.9	68	72	72	58	66	81		
MV6-7.5-2	7.5	5.5	20	380	2,780	13.3	52.7	70	73	75	63	71	84	623	42
				400	2,795	12.8	50.6	71	74	76	59	67	82		
				415	2,805	12.3	48.7	72	75	77	58	66	81		
MV6-10-2	10	7.5	20	380	2,790	17.2	66.4	77	79	79	63	71	84	703	48
				400	2,805	16.5	63.8	79	80	80	59	67	82		
				415	2,815	16.1	62.2	79	80	80	58	66	81		
MV6-12.5-2*	12.5	9.3	20	380	2,850	20.8	80.3	80	81	81	63	71	84	743	53
				400	2,855	20.2	78.1	80	81	81	59	67	82		
				415	2,865	19.5	75.3	81	82	82	58	66	81		
MV6-15-2	15	11	20	380	2,810	23.7	91.6	81	82	82	67	75	86	796	58
				400	2,825	22.8	88.0	82	83	83	63	71	84		
				415	2,835	22.2	85.9	82	83	83	61	69	83		
MV6-17.5-2*	17.5	13	20	380	2,820	28.7	110.9	80	81	81	65	73	85	856	63
				400	2,835	27.6	106.6	81	82	82	61	69	83		
				415	2,845	26.6	102.7	82	83	83	59	67	82		
MV6-20-2	20	15	20	380	2,850	33.1	127.9	80	81	81	65	73	85	918	70
				400	2,855	32.2	124.5	80	81	81	61	69	83		
				415	2,865	31.0	120.0	81	82	82	59	67	82		
MV6-25-2	25	18.5	20	380	2,850	41.8	161.6	80	81	81	61	69	83	951	74
				400	2,865	40.2	155.4	81	82	82	58	66	81		
				415	2,875	38.8	149.8	82	83	83	57	65	80		
MV6-30-2	30	22	20	380	2,860	48.5	187.6	81	82	82	63	71	84	1,051	85
				400	2,875	46.7	180.3	82	83	83	59	67	82		
				415	2,885	45.0	173.9	83	84	84	58	66	81		
MV6-35-2*	35	26.5	26.5	380	2,870	56.4	217.9	83	84	84	65	73	85	1,166	96
				400	2,885	54.9	212.0	83	84	84	61	69	83		
				415	2,895	52.9	204.4	84	85	85	59	67	82		
MV6-40-2	40	30	26.5	380	2,880	64.6	249.7	82	83	83	65	73	85	1,196	101
				400	2,895	62.1	240.0	83	84	84	61	69	83		
				415	2,905	59.9	231.4	84	85	85	59	67	82		
MV6-50-2	50	37	26.5	380	2,890	79.7	315.6	80	81	83	65	73	85	1,296	108
				400	2,905	76.7	303.3	81	82	84	61	69	83		
				415	2,915	74.7	288.8	83	84	84	59	67	82		
MV6-60-2*	60	45	26.5	380	2,890	96.9	374.7	82	81	83	65	73	85	1,296	108
				400	2,905	93.2	360.2	81	82	84	61	69	83		
				415	2,915	87.7	339.0	83	84	84	59	67	85		

\* Not a stocked item. Contact factory for price and lead time.

### Motor specifications

Outside diameter: 142 mm

Flange standard: 6 in. NEMA

Winding wire: PE2-PA

Working positions: Vertical and horizontal

Ambient water temperature: Max. 50°C (122°F); 70°C (158°F) optional

Rotation directions: CW and CCW

Motor shaft: Stainless steel

*We reserve the right to change all info and data without prior notice.*

**MV6: 6 in. at 60 Hz**

Model	Power		Axial load, kN	Voltage, V	Speed n <sub>r</sub> , rpm	I N, A	I A, A	Motor efficiency at % load, %			Power factor (φ) at % load, %			Length, in.	Weight, lb
	hp	kW						@50%	@75%	@100%	@50%	@75%	@100%		
MV6-5.5-2*	5.5	4	20	220	3,510	19.2	102	69	74	76	51	63	72	23.4	83.8
				380	3,540	11.4	61	65	71	76	50	62	70		
				460	3,530	8.8	47	69	75	77	55	66	74		
MV6-7.5-2	7.5	5.5	20	220*	3,480	23.8	126	73	77	77	60	72	79	24.5	92.6
				380*	3,490	13.6	72	75	77	77	63	74	80		
				460	3,490	11.7	62	73	76	75	64	75	79		
MV6-10-2	10	7.5	20	220*	3,480	32.8	174	74	78	78	57	70	77	27.7	105.8
				380*	3,490	18.3	97	75	78	78	63	74	80		
				460	3,480	15.1	80	74	77	77	66	76	81		
MV6-12.5-2*	12.5	9.3	20	220	3,480	40.7	216	74	78	78	58	70	77	29.3	116.8
				380	3,480	22.4	119	76	79	79	63	74	80		
				460	3,470	18.3	97	77	79	79	66	77	81		
MV6-15-2	15	11	20	220*	3,480	46.3	245	76	79	80	59	71	78	31.3	127.9
				380*	3,500	26.5	140	76	80	80	61	73	79		
				460	3,490	21.3	113	77	80	79	67	76	82		
MV6-17.5-2*	17.5	13	20	220	3,490	56.9	302	75	79	80	54	67	75	33.7	138.9
				380	3,510	31.7	168	76	80	81	58	70	77		
				460	3,500	25.2	134	77	80	80	64	75	81		
MV6-20-2	20	15	20	220*	3,490	60.1	318	79	82	82	62	73	80	36.1	154.3
				380*	3,500	34.4	182	80	82	82	65	76	81		
				460	3,500	28.4	150	79	81	81	67	77	82		
MV6-25-2	25	18.5	20	220*	3,480	77.9	413	76	80	81	58	70	77	37.4	163.1
				380*	3,500	46.3	245	75	79	80	57	69	76		
				460	3,490	35.9	190	79	81	81	64	75	80		
MV6-30-2	30	22	20	220*	3,500	91.6	495	81	83	83	64	73	76	41.4	187.4
				380*	3,520	52.4	283	81	83	83	66	74	77		
				460	3,510	41.1	222	82	83	83	71	78	81		
MV6-35-2*	35	26.5	26.5	220	3,500	110.5	597	82	84	84	62	71	75	45.9	211.6
				380	3,510	60.0	324	82	84	84	61	73	80		
				460	3,510	48.9	264	82	83	83	63	75	82		
MV6-40-2	40	30	26.5	220*	3,500	124.8	674	77	81	82	57	70	77	45.9	222.7
				380*	3,520	68.7	371	78	82	83	61	73	80		
				460	3,510	56.1	303	80	83	83	63	74	81		
MV6-50-2	50	37	26.5	220*	3,500	155.9	842	76	80	81	58	70	77	51.0	238.1
				380*	3,520	90.2	487	76	80	81	58	70	77		
				460	3,510	69.2	374	81	83	84	62	74	80		
MV6-60-2*	60	45	26.5	220	3,500	189.5	1023	75	79	80	58	71	78	51.0	238.1
				380	3,520	109.7	592	75	79	80	58	71	78		
				460	3,510	84.1	454	80	82	83	62	75	81		

\* Not a stocked item. Contact factory for price and lead time.

**Motor specifications**

Outside diameter: 5.6 in.

Flange standard: 6 in. NEMA

Winding wire: PE2-PA

Working positions: Vertical and horizontal

Ambient water temperature: Max. 50°C (122°F); 70°C (158°F) optional

Rotation directions: CW and CCW

Motor shaft: Stainless steel

We reserve the right to change all info and data without prior notice.

**MV8: 8 in. at 50 Hz**

Model	Power		Axial load, kN	Voltage, V	Speed n <sub>N</sub> , rpm	I <sub>N</sub> , A	I <sub>A</sub> , A	Motor efficiency at % load, %			Power factor (φ) at % load, %			Length, mm	Weight, kg
	hp	kW						@50%	@75%	@100%	@50%	@75%	@100%		
MV8-40-2	40	30	45	380	2,880	63.2	239	82	83	83	73	78	87	948	125
				400	2,895	60.7	229	83	84	84	67	74	85		
				415	2,905	59.2	223	83	84	84	65	73	84		
MV8-50-2	50	37	45	380	2,890	76.1	287	84	85	85	73	78	87	1,008	134
				400	2,905	73.1	276	85	86	86	67	74	85		
				415	2,915	72.2	269	85	86	86	65	73	84		
MV8-60-2	60	45	45	380	2,890	92.6	349	84	85	85	73	78	87	1,093	148
				400	2,905	89.0	336	85	86	86	67	74	85		
				415	2,915	86.8	327	85	86	86	65	73	84		
MV8-70-2*	70	52	45	380	2,890	105.7	399	84	85	85	75	81	88	1,178	166
				400	2,905	101.6	383	85	86	86	70	76	86		
				415	2,915	99.1	374	85	86	86	67	74	85		
MV8-75-2	75	55	45	380	2,890	113.2	427	83	84	84	75	81	88	1,178	166
				400	2,905	110.0	415	83	84	84	70	76	86		
				415	2,915	106.0	400	84	85	85	67	74	85		
MV8-80-2*	80	60	45	380	2,890	122.0	460	85	86	86	73	78	87	1,233	181
				400	2,905	118.6	447	85	86	86	67	74	85		
				415	2,915	115.7	436	85	86	86	65	73	84		
MV8-90-2*	90	67	45	380	2,890	137.8	520	84	85	85	73	78	87	1,258	186
				400	2,905	132.4	499	85	86	86	67	74	85		
				415	2,915	129.2	487	85	86	86	65	73	84		
MV8-100-2	100	75	45	380	2,890	154.3	582	83	84	84	75	81	88	1,283	191
				400	2,905	148.3	559	84	85	85	70	76	86		
				415	2,915	144.6	545	84	85	85	67	74	85		
MV8-110-2*	110	81	55	380	2,895	166.6	629	84	85	85	73	78	87	1,363	201
				400	2,900	160.1	604	85	86	86	67	74	85		
				415	2,905	156.2	589	85	86	86	65	73	84		
MV8-125-2	125	92	55	380	2,860	189.2	714	84	85	85	73	78	87	1,428	208
				400	2,875	181.9	686	85	86	86	67	74	85		
				415	2,890	177.4	669	85	86	86	65	73	84		
MV8-150-2	150	110	55	380	2,940	223.7	844	84	85	85	72	78	88	1,574	229
				400	2,950	212.5	802	85	86	86	67	74	87		
				415	2,955	204.8	773	85	86	86	65	73	87		

\* Not a stocked item. Contact factory for price and lead time.

**Motor specifications**

Outside diameter: 192 mm

Flange standard: 8 in. NEMA

Winding wire: PE2-PA

Working positions: Vertical and horizontal

Ambient water temperature: Max. 50°C (122°F); 70°C (158°F) optional

Rotation directions: CW and CCW

Motor shaft: Stainless steel

We reserve the right to change all info and data without prior notice.



**MV8: 8 in. at 60 Hz**

Model	Power		Axial load, kN	Voltage, V	Speed n <sub>r</sub> , rpm	I N, A	I A, A	Motor efficiency at % load, %			Power factor (φ) at % load, %			Length, in.	Weight, lb
	hp	kW						@50%	@75%	@100%	@50%	@75%	@100%		
MV8-40-2	40	30	45	220*	3,480	115.1	612	81	84	84	77	78	82	37.3	275.6
				380*	3,490	66.3	352	82	84	84	77	78	82		
				460	3,480	54.1	288	81	83	83	79	81	84		
MV8-50-2	50	37	45	220*	3,490	139.5	742	82	85	85	77	78	82	39.7	295.4
				380*	3,500	80.7	430	82	85	85	77	78	82		
				460	3,480	65.9	351	83	84	84	79	81	84		
MV8-60-2	60	45	45	220*	3,480	167.6	892	83	85	85	70	78	83	43.0	326.3
				380*	3,490	97.0	516	83	85	85	70	78	83		
				460	3,490	79.2	421	84	85	85	74	81	84		
MV8-70-2*	70	52	45	220	3,490	189.1	1,000	84	86	86	72	80	84	46.4	366.0
				380	3,500	109.5	583	84	86	86	72	80	84		
				460	3,495	90.4	481	84	85	85	76	83	85		
MV8-75-2	75	55	45	220*	3,490	200.0	1,064	84	86	86	68	77	84	46.4	366.0
				380*	3,500	115.8	616	84	86	86	68	77	84		
				460	3,500	95.7	509	85	86	86	74	81	84		
MV8-80-2*	80	60	45	220	3,490	215.7	1,148	85	87	87	74	81	84	48.5	399.0
				380	3,500	124.9	664	85	87	87	74	81	84		
				460	3,500	103.1	549	85	86	86	77	83	85		
MV8-90-2*	90	67	45	220	3,500	252.7	1,344	84	86	86	70	79	81	49.5	410.1
				380	3,510	146.3	778	84	86	86	70	79	81		
				460	3,500	116.5	620	85	86	86	74	82	84		
MV8-100-2	100	75	45	220*	3,490	266.5	1,418	85	87	87	74	82	85	50.5	421.1
				380*	3,500	154.3	821	85	87	87	74	82	85		
				460	3,500	127.4	678	85	87	87	74	82	85		
MV8-110-2*	110	81	55	380	3,500	166.6	886	85	87	87	72	80	85	56.2	443.1
				460	3,500	137.6	732	86	87	87	77	83	85		
MV8-125-2	125	92	55	380*	3,490	191.5	1,019	86	87	87	74	80	84	53.7	458.6
				460	3,490	158.2	842	86	87	87	73	80	84		
MV8-150-2	150	110	55	380*	3,490	231.6	1,232	86	86	86	74	80	84	62.0	504.9
				460	3,490	191.3	1,018	86	86	86	73	80	84		

\* Not a stocked item. Contact factory for price and lead time.

**Motor specifications**

**Outside diameter:** 7.6 in.

**Flange standard:** 8 in. NEMA

**Winding wire:** PE2-PA

**Working positions:** Vertical and horizontal

**Ambient water temperature:** Max. 50°C (122°F); 70°C (158°F) optional

**Rotation directions:** CW and CCW

**Motor shaft:** Stainless steel

*We reserve the right to change all info and data without prior notice.*

## MV10: 10 in. at 50 Hz

Model	Power		Axial load, kN	Voltage, V	Speed n <sub>v</sub> , rpm	I N, A	I A, A	Motor efficiency at % load, %			Power factor (φ) at % load, %			Length, mm	Weight, kg
	hp	kW						@50%	@75%	@100%	@50%	@75%	@100%		
MV10-110-2	110	81	75	380	2,890	164.7	615	84	84	85	76	81	88	1,282	188
				400	2,905	158.3	590	85	85	86	72	77	86		
				415	2,915	152.6	569	86	86	87	69	75	85		
MV10-125-2	125	92	75	380	2,900	184.9	690	85	85	86	76	81	88	1,342	201
				400	2,915	179.8	671	85	85	86	72	77	86		
				415	2,925	175.3	654	85	85	86	69	75	85		
MV10-150-2	150	110	75	380	2,900	223.6	835	85	85	86	74	80	87	1,422	249
				400	2,915	217.5	811	85	85	86	69	75	85		
				415	2,925	212.1	791	85	85	86	66	73	84		
MV10-175-2	175	129	75	380	2,920	256.3	957	86	86	87	76	81	88	1,522	249
				400	2,935	246.3	919	87	87	88	72	77	86		
				415	2,945	240.2	896	87	87	88	69	75	85		
MV10-200-2	200	147	75	380	2,910	292.1	1,090	86	86	87	76	81	88	1,652	272
				400	2,925	283.9	1,059	86	86	87	72	77	86		
				415	2,935	273.7	1,020	87	87	88	69	75	85		
MV10-225-2*	225	166	75	380	2,900	333.7	1,245	85	85	86	76	81	88	1,732	279
				400	2,915	320.6	1,196	86	86	87	72	77	86		
				415	2,925	312.7	1,165	86	86	87	69	75	85		
MV10-250-2	250	185	75	380	2,905	371.8	1,388	85	85	86	76	81	88	1,732	287
				400	2,915	361.5	1,348	85	85	86	72	77	86		
				415	2,925	348.4	1,299	86	86	87	69	75	85		
MV10-300-2	300	220	75	380	2,905	442.2	1,651	85	85	86	76	81	88	1,922	302
				400	2,915	429.9	1,604	85	85	86	72	77	86		
				415	2,925	414.4	1,546	86	86	87	69	75	85		

\* Not a stocked item. Contact factory for price and lead time.

### Motor specifications

Outside diameter: 232 mm

Flange standard: 8 in. NEMA

Winding wire: PE2-PA

Working positions: Vertical and horizontal

Ambient water temperature: Max. 50°C (122°F); 70°C (158°F) optional

Rotation directions: CW and CCW

Motor shaft: Stainless steel

We reserve the right to change all info and data without prior notice.

**MV10: 10 in. at 60 Hz**

Model	Power		Axial load, kN	Voltage, V	Speed n <sub>N</sub> , rpm	I <sub>N</sub> , A	I <sub>A</sub> , A	Motor efficiency at % load, %			Power factor (φ) at % load, %			Length, in.	Weight, lb
	hp	kW						@50%	@75%	@100%	@50%	@75%	@100%		
MV10-110-2*	110	81	75	380	3,500	170.5	904	85	85	85	80	83	85	50.5	414.5
				460	3,510	137.6	729	85	85	85	82	85	87		
MV10-125-2	125	92	75	380*	3,510	193.7	1,027	85	85	85	80	83	85	52.8	443.1
				460	3,520	156.3	829	85	85	85	82	85	87		
MV10-150-2	150	110	75	380*	3,515	234.3	1,242	85	86	85	79	82	84	56.0	549.0
				460	3,520	189.1	1,002	85	86	85	81	84	86		
MV10-175-2	175	129	75	380*	3,520	268.4	1,423	86	87	86	80	83	85	60.0	549.0
				460	3,530	216.7	1,148	86	87	86	82	85	87		
MV10-200-2	200	147	75	380*	3,515	305.9	1,621	86	86	86	80	83	85	65.0	599.7
				460	3,520	246.9	1,308	86	86	86	82	85	87		
MV10-225-2*	225	166	75	380	3,505	345.4	1,831	86	86	86	80	83	85	68.2	615.1
				460	3,510	278.8	1,478	86	86	86	82	85	87		
MV10-250-2	250	185	75	380*	3,505	385.0	2,040	86	86	86	80	83	85	68.2	632.7
				460	3,510	310.7	1,647	86	86	86	82	85	87		
MV10-300-2	300	220	75	380*	3,505	457.8	2,426	86	86	86	80	83	85	75.7	665.8
				460	3,510	369.5	1,958	86	86	86	82	85	87		

\* Not a stocked item. Contact factory for price and lead time.

**Motor specifications**

Outside diameter: 9.1 in.

Flange standard: 8 in. NEMA

Winding wire: PE2-PA

Working positions: Vertical and horizontal

Ambient water temperature: Max. 50°C (122°F); 70°C (158°F) optional

Rotation directions: CW and CCW

Motor shaft: Stainless steel

*We reserve the right to change all info and data without prior notice.*

## Proven, long-lasting motors

### Motor water filling

During storage and delivery, antifreeze is used to prevent freezing. H2O+ standard motors are filled with a water/glycol mixture to protect against freezing to -10°C (14°F).

All H2O+ motors are pre-filled at the factory for immediate installation. However, each motor may be checked for proper filling prior to installation, if desired. Please refer to the Flowserve Byron Jackson H2O+ IOM for checking the motor for proper fluid amount and topping off.

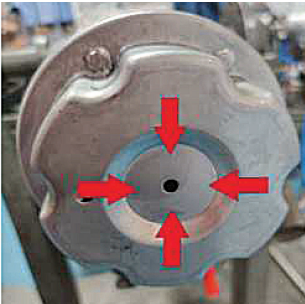

### Insulation resistance test

All motors are subjected to a final insulation resistance test (megaohm or megger test) at 3,000 V prior to shipment and must show at least 2,000 MΩ resistance to be shipped. A megaohm test should be performed prior to and after any splicing during installation. See the Flowserve Byron Jackson H2O+ IOM for more details.

During installation, once the splices of the drop cable are under water, perform another megaohm test at the surface. If the insulation test results for any winding are lower than 100 MΩ, the cable splice may be faulty and should be corrected.

After installation, the motor should have about 2 MΩ resistance at 500 V. If the insulation resistance drops to below 0.5 MΩ at 500 V, there may be an insulation problem and the motor may need to be removed and inspected.

*A megaohm test should be performed prior to and after any splicing during installation.*



### Use cooling jacket

H2O+ submersible motors are cooled by the flow of water across the motor. Having the proper flow across the motor is very important and must be within an acceptable range to properly cool the motor.

To ensure a long service life for submersible motors, the motors must be cooled properly. The required minimum flow velocity across the motor is given in the table below.

If the submersible motor will be installed in an open body of water or the diameter of the well is too large to reach minimum flow velocity across the motor, a flow sleeve must be used to provide the appropriate flow velocity to at least the minimum flow velocity listed in the table. For more information, please refer to Flowserve Byron Jackson H2O+ IOM.

Type	Motor power rating	Min. water flow, m/s (ft/s)
6 in.	5.5 to 18.5 kW	0.2 (0.66)
	22 to 45 kW	0.5 (1.6)
8 in.	30 to 55 kW	0.2 (0.66)
	60 to 110 kW	0.5 (1.6)
10 in.	81 to 220 kW	0.5 (1.6)

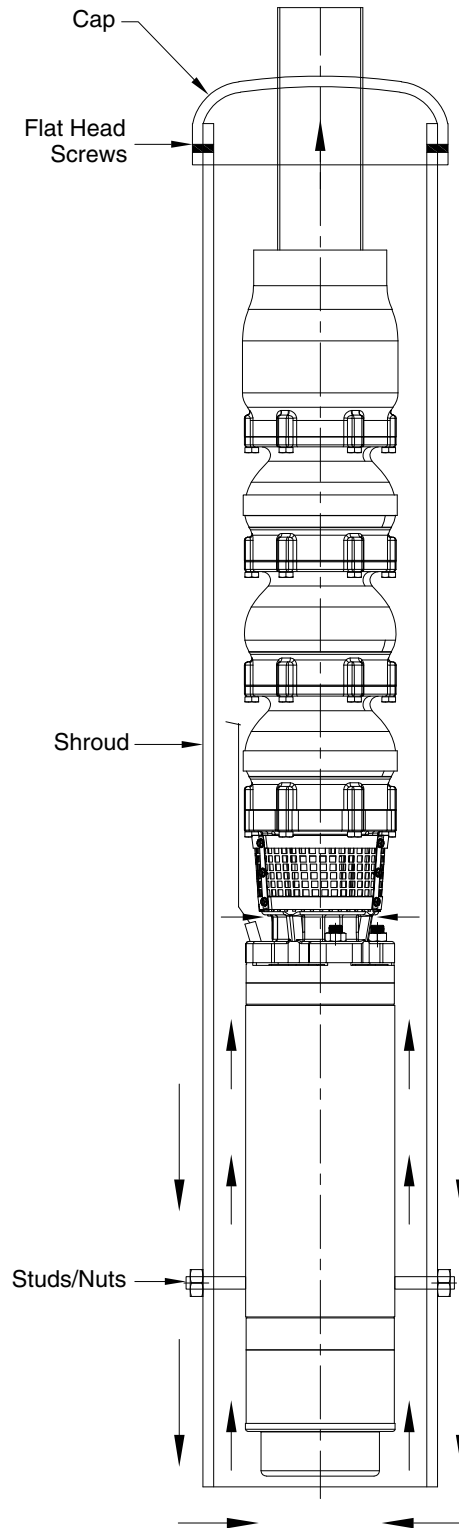

## Additional information

### Use frequency convertor and soft starter

The points listed below should be taken into consideration while operating submersible motors with a frequency convertor and soft starter.

- Needed precautions should have been taken to protect your frequency convertor from voltage fluctuations.
- Flow rate around motor must be at least 0.15 m/s (0.5 ft/s). If flow rate is not enough, flow inducer sleeve must be used to provide the needed flow rate.
- In systems that are operated by a frequency convertor and soft starter, choosing the next higher motor rate will provide long service life for the motors.
- Motors should be operated between 40 to 60 Hz (U.S.) or 30 to 50 Hz (international) with frequency converters. As the protective water layer can't be formed on thrust bearing at lower frequencies, the motor would get damaged.
- Dual slope frequency converters also should be used while using a soft starter.
- VFD acceleration and deceleration should be set to no more than second to reach the minimum frequency.



### Voltage drop and cable power loss

To determine the cable section, the voltage drop must not exceed 3%. The formulas used for voltage drop calculation are given below.

#### Direct starter

1. Cable

$$U_v = \frac{3.1 \times L \times I \times \cos\varphi}{q \times U} \quad q = \frac{3.1 \times L \times I \times \cos\varphi}{U_v\% \times U}$$

2. Cables in parallel

$$U_v = \frac{1.55 \times L \times I \times \cos\varphi}{q \times U} \quad q = \frac{1.55 \times L \times I \times \cos\varphi}{U_v\% \times U}$$

#### Delta star starter

$$U_v = \frac{2.1 \times L \times I \times \cos\varphi}{q \times U} \quad q = \frac{2.1 \times L \times I \times \cos\varphi}{U_v\% \times U}$$

**L** = Cable length (m)  
**I** = Current at nominal vol. (A)  
**q** = Conductor section (mm<sup>2</sup>)  
**cosφ** = Power factor  
**P<sub>v</sub>** = Power loss (%)  
**U<sub>v</sub>** = Voltage drop (%)  
**U** = Nominal voltage (V)

Calculation for power loss through cable:

$$P_v = \frac{U_v}{\cos^2\varphi}$$

## Troubleshooting guide

### Motor does not start

Possible cause	Remedy
No power or incorrect voltage	Check voltage at lines; contact power company if voltage is incorrect
Fuses blown or circuit breakers tripped	Replace with proper fuse or reset circuit breakers
Control box malfunction	Repair or replace
Defective wiring	Correct faulty wiring or connections
Bound pump	Pull pump and correct problem; run new installation until the water cleans
Defective cable or motor	Repair or replace

### Motor starts too often

Possible cause	Remedy
Check valve stuck open	Replace if defective
Waterlogged tank	Repair or replace
Leak in system	Replace damaged pipes or repair leaks

### Motor runs continuously

Possible cause	Remedy
Low water level in well	Throttle pump outlet or reset pump to lower level; do not lower if sand may block pump
Worn pump	Pull pump and replace worn parts
Loose coupling or broken motor shaft	Replace worn or damaged parts
Pump screen blocked	Clean screen and rest pump depth
Check valve stuck closed	Replace if defective
Control box malfunction	Repair or replace

### Motor runs, but overload protector trips

Possible cause	Remedy
Incorrect voltage	Contact power company if voltage is incorrect
Overheated protectors	Shade the box, provide ventilation, or move box away from source
Defective control box	Repair or replace
Defective motor or cable	Repair or replace
Worn pump or motor	Replace pump and/or motor



Flowserve Corporation  
5215 North O'Connor Blvd.  
Suite 700  
Irving, Texas 75039-5421 USA  
Telephone: +1-937-890-5839

**PUTB000871-01 (EN/A4)** May 2023

Flowserve Corporation has established industry leadership in the design and manufacture of its products. When properly selected, this Flowserve product is designed to perform its intended function safely during its useful life. However, the purchaser or user of Flowserve products should be aware that Flowserve products might be used in numerous applications under a wide variety of industrial service conditions. Although Flowserve can provide general guidelines, it cannot provide specific data and warnings for all possible applications. The purchaser/user must therefore assume the ultimate responsibility for the proper sizing and selection, installation, operation, and maintenance of Flowserve products. The purchaser/user should read and understand the Installation Instructions included with the product, and train its employees and contractors in the safe use of Flowserve products in connection with the specific application.

While the information and specifications contained in this literature are believed to be accurate, they are supplied for informative purposes only and should not be considered certified or as a guarantee of satisfactory results by reliance thereon. Nothing contained herein is to be construed as a warranty or guarantee, express or implied, regarding any matter with respect to this product. Because Flowserve is continually improving and upgrading its product design, the specifications, dimensions and information contained herein are subject to change without notice. Should any question arise concerning these provisions, the purchaser/user should contact Flowserve Corporation at any one of its worldwide operations or offices.

©2023 Flowserve Corporation. All rights reserved. This document contains registered and unregistered trademarks of Flowserve Corporation. Other company, product, or service names may be trademarks or service marks of their respective companies.