

# ***Seismic Manual***

---

**Title Page**

***Prepared by:***

***Bureau of Bridges and Structures  
Division of Highways***

***Agency:***

***Illinois Department of Transportation***

***Place of Publication:***

***Springfield Illinois***

**2024**



1-1  
**List of Figures and Tables**

DRAFT



# Section 1 Introduction

As directed by the Engineer of Bridges and Structures, it is the responsibility of the Engineer of Bridge Design to develop, maintain, and administer the policies that govern the design and preparation of plans and specifications for all structures under the jurisdiction of the Department of Transportation. The vehicle by which this policy is controlled is the Bridge Manual.

The Seismic Manual is a supplement to the Bridge Manual. The purpose of this Manual is to aid in the seismic planning, design, detailing, and retrofitting of bridges and structures in Illinois. Presented herein is a compilation of design procedures, design charts and tables, and details.

This manual is an active manual in the respect that as research, revised criteria, and the AASHTO Specification revisions dictate, new or revised sheets may be issued. The version of this Manual found on the Department's website will always be the most current version. If a paper copy is kept, it is strongly urged that revised sheets be immediately incorporated so that the Manual's integrity is maintained.

The seismic design procedure preferred by the Department is a performance-based seismic design, which augments a displacement-based procedure. The intent of this Manual is to provide policy such that bridge planning and design engineers can navigate the necessary documents and provide a design that is consistent with the expectations of the Department.

## 1.1 Codes and Documents

The seismic design of all bridges in the state of Illinois shall adhere to this IDOT Seismic Manual (SM) and the AASHTO Guide Specifications for LRFD Seismic Bridge Design (Guide Specifications, or SGS), in conjunction with the requirements for demand analysis and capacity design in the AASHTO Guidelines for Performance-Based Seismic Bridge Design (GPBSD). Additionally, the AASHTO Guide Specifications for Seismic Isolation Design (GSSID) may be utilized when necessary, as determined by the Engineer of Bridge Design.

The AASHTO LRFD Bridge Design Specifications (LRFD, or AASHTO Code) is the controlling national policy document for bridge design. Guide specifications are intended to augment the policies found in the AASHTO LRFD Bridge Design Specifications, and therefore when policies are found in both documents, the policies found in the guide specifications shall control. When a

policy is not found in guide specifications, the AASHTO LRFD Bridge Design Specifications shall be used.

Similarly, the Seismic Manual (SM) is intended to augment the policies found in the Bridge Manual, providing additional policy and guidance to aid the Engineer in the seismic design process. The intent of the policy documents Bridge Manual and Seismic Manual is to provide state-specific guidance and policy for the AASHTO documents. In the event of a discrepancy between policies in this manual and those found in AASHTO documents, the guidance presented here supersedes the guidance found in the AASHTO documents.

The hierarchy of policy documents in Table 1.1-1 shall be observed.

Policy Document	Controls Over
SM <sup>a</sup> , BM <sup>b</sup>	SGS <sup>c</sup> , LRFD <sup>d</sup> , GPBSD <sup>e</sup> , GSSID <sup>f</sup>
GPBSD,	LRFD, SGS, GSSID
SGS, GSSID	LRFD

*Table 1.1-1*

<sup>a</sup>IDOT Seismic Manual

<sup>b</sup>IDOT Bridge Manual

<sup>c</sup>AASHTO Guide Specifications for LRFD Seismic Bridge Design

<sup>d</sup>AASHTO LRFD Bridge Design Specifications

<sup>e</sup>AASHTO Guidelines for Performance-Based Seismic Bridge Design

<sup>f</sup>AASHTO Guide Specifications for Seismic Isolation Design

The Edition or version of the applicable AASHTO documents used shall be either that shown on the approved Type, Size, and Location (TSL) plans, or newer. It is not necessary for designers to use the most current version of AASHTO documents, given that the versions used are consistent with or more current than the versions shown on the TSL plans. The final plans shall list the AASHTO documents used in seismic design on the General Plan and Elevation sheet.

The SGS use the terminology Seismic Design Categories, or SDC, with letters to denote the categories (A, B, C, and D). Any parallel terminology (e.g. SDS 1, 2, 3, and 4, or SPC I, II, III, and IV) in other AASHTO documents shall be assumed to be equivalent with this terminology.

References to documents will be provided in the format (Reference number, Reference initialism). For example, (8.8.2, SGS) refers to Article 8.8.2 of the AASHTO Guide Specifications for LRFD Seismic Bridge Design. References to other locations within the Seismic Manual will typically state “of this Manual,” “SM,” or be left blank.

## **1.2 Applicability**

Seismic design is defined as application of the Extreme Event I load combination in the AASHTO LRFD Bridge Design Specifications.

Seismic detailing is defined as inclusion of details intended to reduce risk of collapse, prevent the occurrence of undesirable limit-states and/or increase ductility during a seismic event. This includes details such as support lengths, bearing connections, reinforcement details, backfill details, etc.

The SGS was developed to ensure life safety during and after a seismic event. The formulas found in that document are intended to provide robust designs for that limit state. The performance criteria found in this Manual and the Guidelines for Performance-Based Seismic Design may be used in conjunction with the SGS to ensure higher levels of safety e.g. operational or fully operational.

Articles 1.2.1 thru 1.2.6 of this Manual provide specific guidance on when a seismic design is required for various structure types, locations, and conditions.

The SDC of a specific structure, based upon the structure location and site class, plays a major role in the determination of whether a seismic design is required. Policy for determination of SDC for a specific location is found in Section 3 of this document.

Structure Owners and project planners should note that some level of seismic detailing is required for all structures, regardless of SDC. However, the level of seismic detailing required for some bridges, especially in SDC A, is prescriptive and should not amount to considerable engineering costs or construction costs.

### **1.2.1 Structures in SDC A**

Structures in SDC A do not require seismic design. Structures in SDC A require seismic detailing.

### *1.2.2 Multi-Span Bridges*

Seismic design and detailing are required for all multi-span bridges in SDC B, C, and D. Multi-span bridges include both continuous bridges and multiple simple-span bridges with intermediate supports.

### *1.2.3 Retaining Walls*

Seismic design is required for retaining walls meeting any of the following parameters (11.5.4.2, LRFD):

- Located in SDC D
- Peak Ground Acceleration (PGA), or acceleration at 0.0 seconds, greater than 0.4g, according to the 2023 AASHTO Seismic Design Hazard
- Locations where liquefaction triggering is anticipated as a result of the design event
- Retaining wall is required for structural integrity of an adjacent structure requiring seismic analysis, e.g. MSE walls supporting abutments in SDC B, C, or D

### *1.2.4 Culverts, Single-Span Bridges, and Three-Sided Structures*

Culverts and single-span bridges do not require seismic design, regardless of SDC. Culverts do not require seismic detailing. Single-span bridges may require seismic detailing, depending upon the abutment type.

In SDC B, C, or D, if liquefaction or other geoseismic hazards are a concern at a site with a proposed culvert or single-span bridge, verification of effects such as downdrag, lateral spreading, or vertical deflection, may be required. A full seismic analysis, with period and acceleration calculation, is not required.

Three-sided structures do not require a seismic analysis. However, in SDC B, C, and D, there are additional detailing requirements specified in the Department's special provision for three-sided structures, Guide Bridge Special Provision 90.



### *1.2.5 Temporary Bridges and Stage Construction with Duration Greater than Five Years*

In SDC B, C, and D Seismic design is required for temporary bridges expected to remain in service for more than five years, with the exception of single-span temporary bridges.

Seismic design is required for construction stages with an anticipated duration of more than five years.

For temporary conditions lasting more than five years, a reduced design spectral acceleration may be used (3.6, SGS). See Article 3.15.5.3 of this document for more information.

### *1.2.6 Traffic Structures Not Requiring Seismic Design or Detailing*

Other traffic structures such noise abatement walls, sign structures, and light towers do not require seismic design or detailing. If supported by a bridge, the presence of a traffic structure shall be considered in the analysis.

## **1.3 Design Methodology**

Articles 1.3.1 thru 1.3.3 provide a brief overview of displacement-based design, performance-based design, and isolation design.

### *1.3.1 Displacement-Based Design*

The SGS prescribe a displacement-based method of seismic design. In a displacement-based design, seismic loads are applied, displacements are calculated, and the calculated displacements are compared to member displacement capacities. Strength capacities are also compared to applied force effects.

Output from a displacement-based design in the form of member displacements, strains, and ductilities may be used to establish performance criteria. If performance criteria is taken into account in design, this is known as a performance-based design.

### *1.3.2 Performance-Based Design*

The Guidelines for Performance-Based Seismic Design allow for performance-based design. In a performance-based design, the structure Owner determines the allowable post-earthquake traffic, amount of damage, and time to repair. This post-earthquake state will correspond with a Performance Level for the structure. This performance level determines the seismic design requirements for the bridge. In this manner, the Owner and the designer can work together to determine an optimal design, meeting the performance needs of the bridge.

For example, proximity to emergency services or location on an evacuation route may require a bridge to remain open to all traffic after a design-level earthquake. Requiring the bridge to remain open to all traffic would allow for very little damage to be incurred by the structure. Using the performance-based guidelines and SGS, the designer can use a displacement-based design to limit damage to acceptable levels. The designer would be designing the bridge for the specific performance level desired by the owner by way of a performance-based design.

Another example would be if structure is deemed to be allowed to be completely closed after a design-level earthquake. A structure that can be closed after a design-level earthquake incur much more damage than one required to remain open to traffic and would be less expensive to construct. The owner would convey this to the designer, and the designer could design the bridge for a lower performance level.

Performance requirements are provided for the following elements/aspects:

- Reinforced concrete columns, walls, or shafts
- Steel piles
- Anchorage connections between superstructures and substructures
- Overall geometric and rideability concerns such as expansion joints, bearing unseating, and embankment settlement

Performance-based seismic design provides the flexibility to determine bridge seismic performance for distinct seismic input. The performance requirements in the Guidelines for Performance-Based Seismic Design and this Manual are based on one of the following: member displacement, member strain, or member ductility. All three of these require a displacement-based design to determine their magnitude. Therefore, it is logical to incorporate performance-based seismic design into a displacement-based design.

Displacement-based seismic design on its own begins with the assumption of life safety, then works through design methodology without any direct assessment of performance other than to meet this life safety assumption at the design earthquake. Performance-based seismic design begins with the desired performance and work through the process to deliver a bridge that meets the Structure Owners and Designers' desired goals.

The value added from utilizing performance-based design, and displacement-based design by proxy, is the ability for structure owners and designers to plan for seismic events more accurately. More accurate post-earthquake delays and repair costs to be determined. These determinations allow structure owners and designers to establish effective and life-saving emergency response systems.

### *1.3.3 Isolation Design*

The Guide Specifications for Seismic Isolation Design allow for isolation design. Isolation design is used to decrease seismic loads to substructure units by increasing the period of the structure via reducing structure stiffness, while simultaneously increasing structure damping.

Some policies in this Manual, regarding damping levels, incorporate use of some of the concepts of isolation design. For example, increased damping levels due to soil-structure interaction is allowed in the SGS and is allowed as per this Manual. When these policies are used, the designer is already utilizing isolation design concepts, even if not explicitly referencing the GSSID.

Use of the GSSID for a more rigorous isolation design, with isolation bearings, is allowed by the Department. In most cases, use of isolation bearings is not required, and therefore they are only used as an additional tool when necessary. Cases where isolation design may be necessary include:

- Major structures or structures with long spans and high substructure reactions
- Bridges with high demand and short periods, such as short slab bridges or bridges with inflexible substructures, that are also in SDC C or D
- Retrofitting of old bridges where member sizes or reinforcement details cannot be altered

In these cases, use of isolation bearings can significantly reduce seismic loads and overall costs. See Article 7.3.1 for more information.

## **1.4 Earthquake Resisting Systems**

Article 3.3 of the SGS requires that an Earthquake-Resisting System (ERS) be identified for all bridges in SDC C or D, and recommends that one be identified for SDC B. All structures requiring a seismic design shall have an ERS defined in the structure calculations. The ERS consists of the following, found in the referenced articles of this Manual:

- Global Seismic Design Strategy (2.4)
- Earthquake Resisting System (2.5)
- Earthquake Resisting Element (2.6)

The design calculations shall state the Global Seismic Design Strategy, show the Earthquake Resisting System with areas of required ductility indicated, and indicate which Earthquake Resisting Element is used at each area of required ductility.

Additional information on plan notes and details pertaining to Earthquake Resisting Systems is found in Section 8 of this Manual.

## **1.5 Manual Outline, Planning and Design Flowcharts**

To aid in categorization of planning and design requirements, policy is separated into the following sections:

- Section 2: Performance Requirements. This section provides policy for determination of Performance Level, and Performance Requirements
- Section 3: Seismic Hazard. This section provides policy on AASHTO Soil Site Class, Seismic Hazard Spectra, and Geoseismic Hazards
- Section 4: Planning Structure Types. This section provides policy on allowable superstructure and substructure types for bridge planners, to be used in generation of TSL plans for bridges and structures.
- Section 5: Earthquake Resisting Systems. This section provides policy on selection of Global Seismic Design Strategy, Earthquake Resisting Systems, Earthquake Resisting Elements, and Engineering Design Parameters.

- Section 6: Analysis Procedures and Modeling. This section provides policy on analytical procedures and modeling assumptions.
- Section 7: Design Requirements. This section provides policy on seismic design requirements.
- Section 8: Detailing. This sections provides policy on detailing.
- Section 9: Retrofitting. This section provides policy on seismic retrofitting.

### *1.5.1 Responsibilities of Planning and Design Engineers*

The bridge planning engineers are responsible for determining the following parameters for the TSL plans. Article references to this manual are given in parentheses.

- Bridge Operational Category (2.1)
- Ground Motion Level (2.2)
- Soil Site Class (3.2)
- Bridge Latitude and Longitude (3.3)
- Performance Level (2.3)
- Acceleration Spectrum (3.4)
- Seismic Design Category (3.5)
- Geoseismic Hazards (3.8)
- Structure Type (4)

The bridge design engineers are responsible for determining the following parameters for the bridge contract plans. The bridge design engineers are also responsible for performing the seismic analysis and detailing the bridge contract plans accordingly.

- Global Seismic Design Strategy
- Earthquake Resisting System
- Earthquake Resisting Elements
- Engineering Design Parameters

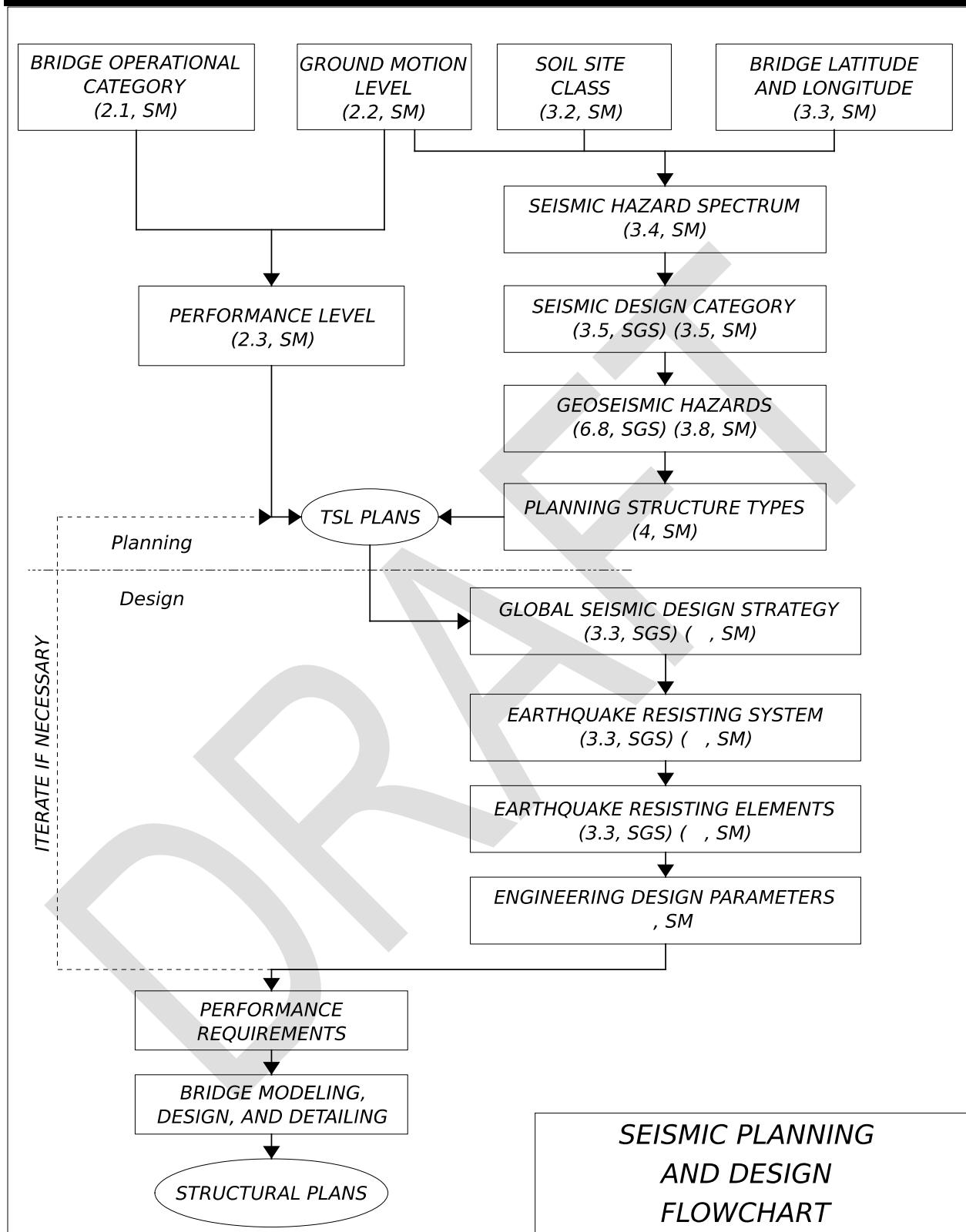

Figure 1.5-1

# Section 2 Performance Level

This section provides policy and procedure for determining the Performance Level of a bridge, to be determined at the TSL phase of plan development. Information on final plan notes pertaining to the Performance Level is found in Section 8 of this Manual.

The Performance Level (PL) of the bridge is based on two parameters.

- The Bridge Operational Category, which is based upon the level and type of traffic required to be accommodated by the bridge after a seismic event. See Article 2.1 of this Manual for the determining the Bridge Operational Category.
- The Ground Motion Level, which is indicative of the severity of the design-level seismic event. See Article 2.2 of this manual.

These two parameters, when combined, give the Performance Level of the bridge, which will then be used to determine design requirements.

## 2.1 Bridge Operational Category

The bridge planning engineer shall work with the structure owner to determine the Operational Category of the bridge during TSL plan development. Instruction on determination of Operational Category is provided below.

A bridge's Operational Category is based upon the level of traffic required to be on a structure immediately after a design-level seismic event.

The Operational Category will affect the performance criteria used to design a new bridge. The Operational Category may affect retrofit requirements for existing bridges.

There are three operational categories prescribed in the GPBSD:

- Critical: Open to all traffic immediately following design-level earthquake. Usable by emergency vehicles and for security/defense purposes after an earthquake larger than the design-level earthquake.

- Recovery: Open only emergency vehicles and for security/defense purposes immediately following the design-level earthquake.
- Ordinary: Closed to all traffic after a design-level earthquake, but no span is expected to collapse as a result of the design-level earthquake. Traffic on the structure during an earthquake will be able to be safely removed from the bridge (i.e., the bridge is designed for life safety purposes only).

The definitions in this Manual have been modified slightly from the definitions in the GPBSD. “Upper-level motion,” used in the GPBSD, is defined herein as the design-level earthquake. “Lower-level motion” is not used by the Department. See Article 2.2 of this manual for more explanation on these terms.

The terms Critical, Recovery, and Ordinary are analogous to the terms Critical, Essential, and Other, found in other AASHTO documents.

For bridges in Illinois, the following Bridge Operational Categories shall be assumed:

Bridge Operational Category	Description
Critical	Major river bridges <sup>a</sup> , including connected approach bridges <sup>b</sup>
Recovery	Bridges on or over IL, US, Interstate routes Non-critical bridges on or over emergency routes <sup>c</sup>
Ordinary	Bridges with Operational Categories not Critical or Recovery. Typically these are owned by local agencies and not on emergency routes. This designation may be increased to Critical or Recovery at the direction of the local agency owner <sup>d</sup>

*Table 2.2-1*

<sup>a</sup>Major river bridges are defined in Article 2.3.6.2.2 of the Bridge Manual. For major river bridges that are over rivers constituting borders with other states, the seismic design criteria for the bridge will be evaluated and agreed upon by all interested parties.

<sup>b</sup>Connected approach bridges include all bridges between the designated abutments for the major river bridge.



°Emergency route maps for Districts 7, 8, and 9 are found in the following location: <https://idot.illinois.gov/Assets/uploads/files/Doing-Business/Manuals-Guides-&-Handbooks/Highways/Bridges/Planning/Bridges%20and%20Structures%20Emergency%20Routes%20for%20Preparation%20of%20TSLs.pdf> . Major river bridges on emergency routes are deemed Critical. All other bridges on emergency routes are deemed Recovery.

°For bridges owned by local agencies, the determination of the Bridge Operational Category is at the discretion of the local agency owner. The lowest Bridge Operational Category is Ordinary, corresponding to a bridge assumed to be closed to traffic after a seismic event. Local agency owners may designate a higher Bridge Operational Category to a specific bridge depending upon agency preference. Potential reasons for a local agency owner to choose a critical or recovery category include:

- Bridge is part of a local emergency plan, such as an evacuation plan
- Bridge provides access to local emergency services such as hospitals
- Bridge carries electric power or water utilities
- Bridge whose closure could create a major economic impact
- Bridge whose closure could eliminate access to a portion of the population or result in unreasonably long detours

For retrofitting of structures, if a Critical or Recovery Bridge Operational Category is designated, this may increase the level of retrofitting required. It also will affect some of the performance-based design requirements for the design of a new bridge. See Section 9 of this manual for more information.

For structures requiring TSL plans, the Bridge Operational Category shall be shown on the TSL plan.

## **2.2 Ground Motion Level**

The bridge planning engineer shall work with the structure owner to determine the Ground Motion Level for the structure. Instruction on determination of Ground Motion Level is provided below.

The GPBSD allows for a multi-tiered analysis of a structure. In a multi-tiered analysis, two design events are considered; an upper-level event with larger seismic accelerations, and a lower-level event with smaller seismic accelerations.

In Illinois, lower-level events have very low seismic accelerations, and are well within accelerations similar to those for SDC A. Because bridges in SDC A locations do not require a seismic design, design for the lower-level event is not required, and only the design for the upper-level event is required.

Therefore, the Ground Motion Level for structures on IL, US, and interstate routes shall be Upper Level.

The 2023 AASHTO Seismic Hazard provides design accelerations consistent with an Upper Level ground motion. This hazard provides accelerations consistent with a 1.5% probability of incipient column collapse in 75 years, or a collapse-based return period of 5000 years. It is noted that, while the return period is much higher than previously used (5000 years vs. 1000 years), the magnitudes of acceleration for a 5000-year collapse event are comparable to those for a 1000-year event which is then designed for inelastic behavior (not collapse). See Article 3.3 of this document, and Article C3.1 of the AASHTO LRFD Bridge Design Specifications, for more information on this hazard.

When major structures requiring site-specific hazard spectra, the analysis will often generate multiple ground motion levels, with the chosen return period subject to discussion. The 2023 AASHTO Seismic Hazard may be used as a comparison to evaluate the results of the site-specific hazard study and determine a level of comparable acceleration.

### **2.3 Performance Level**

The bridge planning engineer shall determine the Performance Level for the structure, using Table 2.3-1 below.

Three Performance Levels, PL1 to PL3, are defined as follows. These definitions are taken from the GPBSD:

- **PL1: Life Safety:** Span loss, and therefore loss of life, is minimized in a design seismic event. However, the design seismic event will impart heavy damage on the structure, and the structure may be required to be replaced after the design seismic event. The bridge will not be expected to remain open to traffic after the design seismic event.
- **PL2: Operational:** Damage sustained to the structure is reparable and the structure has sufficient capacity to allow access to emergency vehicles after the design seismic event. The structure will be reopened to all traffic following emergency repairs.
- **PL3: Fully Operational:** Damage sustained to the structure is minimal, and the structure will remain in service to all traffic immediately following the design seismic event.

To determine the Performance Level (PL) of a bridge, the Bridge Operational Category and Ground Motion Level are used. See Table 14 of the GPBSD for an example with all Operational Categories and Ground Motion Levels.

Because the lower-level Ground Motion Level is not utilized by the Department, the Performance Level simplifies to being based solely on the Bridge Operational Category and upper-level Ground Motion Level.

When only upper-level events are considered, Table 14 of the GPBSD simplifies as follows:

Bridge Operational Category	Ground Motion Level	Performance Level
Critical	Upper	Fully Operational
Recovery	Upper	Operational
Ordinary	Upper	Life Safety

*Table 2.3-1*

DRAFT

## **Section 3 Seismic Hazards**

AASHTO maintains design seismic hazard acceleration spectra, defined by location and soil site class. This hazard spectrum is used by designers to determine the loading and displacements for the structure. It is herein referred to as the “seismic hazard.”

The seismic hazard shall be documented on the TSL plans for all bridges, retaining walls, and three-sided structures, regardless of the applicability requirements in Article 1.3 of this manual. Documentation of this hazard consists of the following. The article reference for this manual is included in parentheses.

- Title “AASHTO Seismic Hazard,” with year (3.1, SM)
- Soil site class (3.2, SM)
- Bridge latitude and longitude (3.3, SM)
- Acceleration spectrum (3.4, SM)
- Seismic Design Category (3.5, SM)
- Site-specific information, when required (3.6, SM)
- Geoseismic hazards (3.7, SM)

Seismic design is not required for culverts, and documentation of the seismic hazard is not required to be shown on TSL plans for culverts.

An example of the required seismic data for TSL plans is given in Figure 3-1.

SEISMIC DATA

2023 AASHTO Seismic Hazard  
Site Class D  
Latitude 37.00° N, Longitude 89.20° W  
Performance Level Operational

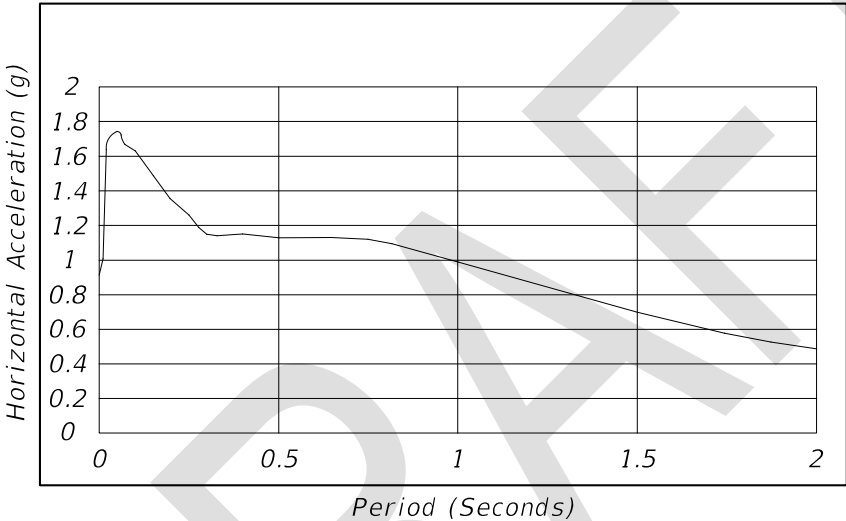

Vertical Acceleration =  $\frac{2}{3}$  \* Horizontal Acceleration

SD1 = 0.989g  
SDC D

SEISMIC DATA  
TYPE, SIZE, AND  
LOCATION PLAN

Figure 3-1

**3.1 AASHTO Seismic Hazard**

The title “AASHTO Seismic Hazard,” with year, shall be shown on the TSL plans. Explanation of the 2023 AASHTO Seismic Hazard is given below.

Unlike previous versions of AASHTO seismic hazards, the 2023 AASHTO Seismic Hazard is not found in the LRFD Code or SGS documents. It is provided at the following location:

<https://earthquake.usgs.gov/ws/designmaps/aashto-2023/>

The 2023 AASHTO Seismic Hazard utilizes a risk-based approach based on a 1.5% probability of incipient concrete column collapse in 75 years. This equates to a 5000-year return period. For locations in Illinois, the accelerations resulting from a 5000-year collapse event are not very different from the accelerations resulting from a 1000-year event used for inelastic design. Therefore, the design accelerations are comparable between the 2023 AASHTO Seismic Hazard and previous hazards such as the 2008 AASHTO Seismic Hazard.

When retrofitting existing structures, the current AASHTO Seismic Hazard should be considered. There may be occasions where retrofitting existing bridges to the current hazard is cost-prohibitive or incompatible with existing details. If this is the case, the designer should consult with the Bureau of Bridges and Structures or local agency to determine the level of the retrofit. This may involve using a reduced EQ load factor to approximate a lower return period. See Section 11 for more information on seismic retrofitting.

**3.2 Site Class**

Site class shall be shown on the TSL plans.

The 2023 AASHTO Seismic Hazard contains eight site classes. The site classes are based upon the weighted average of the shear wave velocity of the upper 100 ft. of soil layers at the location of the soil boring. To determine the site class for a structure, the following steps must be taken:

- Obtain shear wave velocities for individual layers from soil boring data (3.1.1, SM)
- Generate weighted average of shear wave velocities for soil layers within one soil boring (3.1.2, SM)

- Determine Site Class based on average shear wave velocity for structure location (3.1.3, SM)

Shear wave velocities and soil site classes should be documented in the Structure Geotechnical Report for each soil boring location.

See document [LRFD Soil Site Class Definition](#) found on IDOT website for an example.

**3.2.1 Obtain Shear Wave Velocities for Soil Layers from Soil Boring Data**

The AASHTO 2023 Seismic Hazard requires the use of shear wave velocity to determine site class.

Use of Cone Penetrometer Tests (CPT) to determine shear wave velocities is becoming more common. CPT is considered to be more accurate and is the preferred method of determination of soil data. However, IDOT still commonly uses Standard Penetrometer Tests (SPT) to determine soil data, which cannot provide shear wave velocities directly. When shear wave velocities are not directly obtainable on a project, the formulas in Table 3.2.1-1 may be used to convert blow counts ( $N_{60}$ ) and overburden stresses ( $\sigma'_v$ ) to shear wave velocities ( $v_s$ ).

Soil Type	Shear Wave Velocity $v_s$ for Quarternary Soils (m/s)	Age Scaling Factors	
		Holocene	Pleistocene
Clays and Silts	$26N_{60}^{0.17}\sigma'_v{}^{0.32}$	0.88	1.12
Sands	$30N_{60}^{0.23}\sigma'_v{}^{0.23}$	0.9	1.17
Gravels- Holocene	$53N_{60}^{0.19}\sigma'_v{}^{0.18}$	----	----
Gravels- Pleistocene	$115N_{60}^{0.17}\sigma'_v{}^{0.12}$	----	----

*Table 3.2.1-1*

Where:

$N_{60}$  = SPT blow count corrected for hammer efficiency (blows/ft.), not to be taken as greater than 100

$\sigma'_v$  = vertical effective stress (kPa)



Values of  $N_{60}$  and  $\sigma'_v$  are determined from soil boring data. The epoch of the soil (Holocene or Pleistocene) is determined by the geotechnical engineer and is found in the Structure Geotechnical Report.

When bedrock is encountered, shear wave velocities may be obtained from rock core data. In lieu of actual shear wave velocity measurements, the shear wave velocity of rock may be assumed to be 2500 ft. / s.

Shear wave velocities shall be calculated for each individual layer in a soil boring. The velocities for the individual layers will be averaged to determine a shear wave velocity for a boring location. See Article 3.2.2 of this manual for more information.

These formulas are taken from Table 4.11 of the document Guidelines for PEER 2012/08-Estimation of Shear Wave Velocity Profiles (Wair, DeJong, Shantz, December 2012). The Department has performed a verification study of these formulas using data from projects where both SPT and CPT have been performed. The Department will continue to verify CPT and SPT correlation as more data is collected.

When using the above formulas, there is significant scatter in the correlation. AASHTO SGS Article 3.4.2.2 recommends that the resulting shear wave velocities from these conversion equations be modified by a factor of 1.3 or (1 / 1.3) to account for this scatter. The verification study performed by the Department has not proved that use of this factor is warranted, and the above formulas shall be used without additional modification. If future data shows that use of a modification factor is warranted, the Department will adjust its policy accordingly.

### *3.2.2 Determine Weighted Average of Shear Wave Velocity*

For each boring location, an average shear wave velocity,  $\bar{v}_s$ , shall be calculated using the weighted average equations found in Method A in Table C3.10.3.1-1 of the LRFD Code or Eq. 3.4.2.2-1 of the SGS:

$$\bar{v}_s = \frac{\sum_{i=1}^n d_i}{\sum_{i=1}^n \frac{d_i}{v_{si}}}$$

(Table C3.10.3.1-1, LRFD, and Eq. 3.4.2.2-1, SGS)

Where:

$d_i$  = thickness of  $i^{\text{th}}$  soil layer (ft.)

$v_{si}$  = shear wave velocity of  $i^{\text{th}}$  soil layer (ft./sec.)

The shear wave velocity shall be calculated for the top 100 ft. of soil in the boring. When bedrock is not encountered and soil bearings do not extend 100 ft. below the ground surface, the shear wave velocity for the deepest three soil layers sampled shall be averaged and used for the remainder of the 100 ft. required depth.

For bridges with units with lengths not exceeding 750 ft., or when soil boring spacing does not exceed 200 ft., the shear wave velocities for each boring may be averaged to determine a global site class for the structure.

For bridges with units with lengths exceeding 750 ft., or when soil boring spacing exceeds 200 ft., the TSL plans shall provide individual site classes for each substructure unit.

**3.2.3 Site Classification Boundaries by Shear Wave Velocity**

Site classification shall be performed using the boundaries used in Table 3.2.3-1.

Site Class	Shear Wave Velocity $\bar{v}_s$ (ft. / s)
A	$\bar{v}_s > 5000$
B	$3000 < \bar{v}_s \leq 5000$
BC	$2100 < \bar{v}_s \leq 3000$
C	$1450 < \bar{v}_s \leq 2100$
CD	$1000 < \bar{v}_s \leq 1450$
D	$700 < \bar{v}_s \leq 1000$
DE	$500 < \bar{v}_s \leq 700$
E	$\bar{v}_s \leq 500$

*Table 3.2.3-1*

**3.3 Bridge Latitude and Longitude**

Bridge latitude and longitude shall be shown on the TSL plans.

The 2023 AASHTO Seismic Hazard contains data points at intervals of 0.05 degrees latitude and longitude. Latitude and longitude shown on TSL plans therefore shall be shown to at least the nearest 0.05 degrees. This is accurate to a distance of approximately 1.5 miles.

### **3.4 Acceleration Spectrum**

The 2023 AASHTO Seismic Hazard tool, described in Article 3.1 of this document, provides design accelerations for a specific location, corresponding to 22 structure periods. This hazard spectrum shall be reproduced in graphical form on the TSL plans for periods from 0.0 seconds to 2.0 seconds. For bridges with periods exceeding 2.0 seconds, this domain can be extended accordingly. See Figure 3-1 for an example.

### **3.5 Seismic Design Category**

The Seismic Design Category shall be shown on the TSL plans. See Figure 3-1.

The Seismic Design Category (SDC) is based on the seismic acceleration at a specific latitude and longitude, for a structure with a period of one second, modified for site class ( $S_{D1}$ ).

$S_{D1}$  shall be taken as the larger of the following:

- The spectral acceleration coefficient,  $S_a$ , at 1 second
- For locations with  $v_s > 1,450$  ft. / sec., 90% of the maximum value of the product  $TS_a$  for periods from 1.0 seconds to 2.0 seconds
- For locations with  $v_s \leq 1,450$  ft. / sec., 90% of the maximum value of the product  $TS_a$  for periods from 1.0 seconds to 5.0 seconds

SDC definitions in terms of  $S_{D1}$  are shown in Table 3.5-1 of the SGS.

Figures depicting the 2023 AASHTO Seismic Hazard in Illinois are given in Figures 3.6-1 to 3.6-8 of this document. There is one figure for each site class, showing SDC zones within the state for that site class. These maps are based upon the period at 1 second only; the additional calculations for 1.0 second to 2.0 or 5.0 seconds above are not considered in these figures. These figures are for quick reference and preliminary planning only.

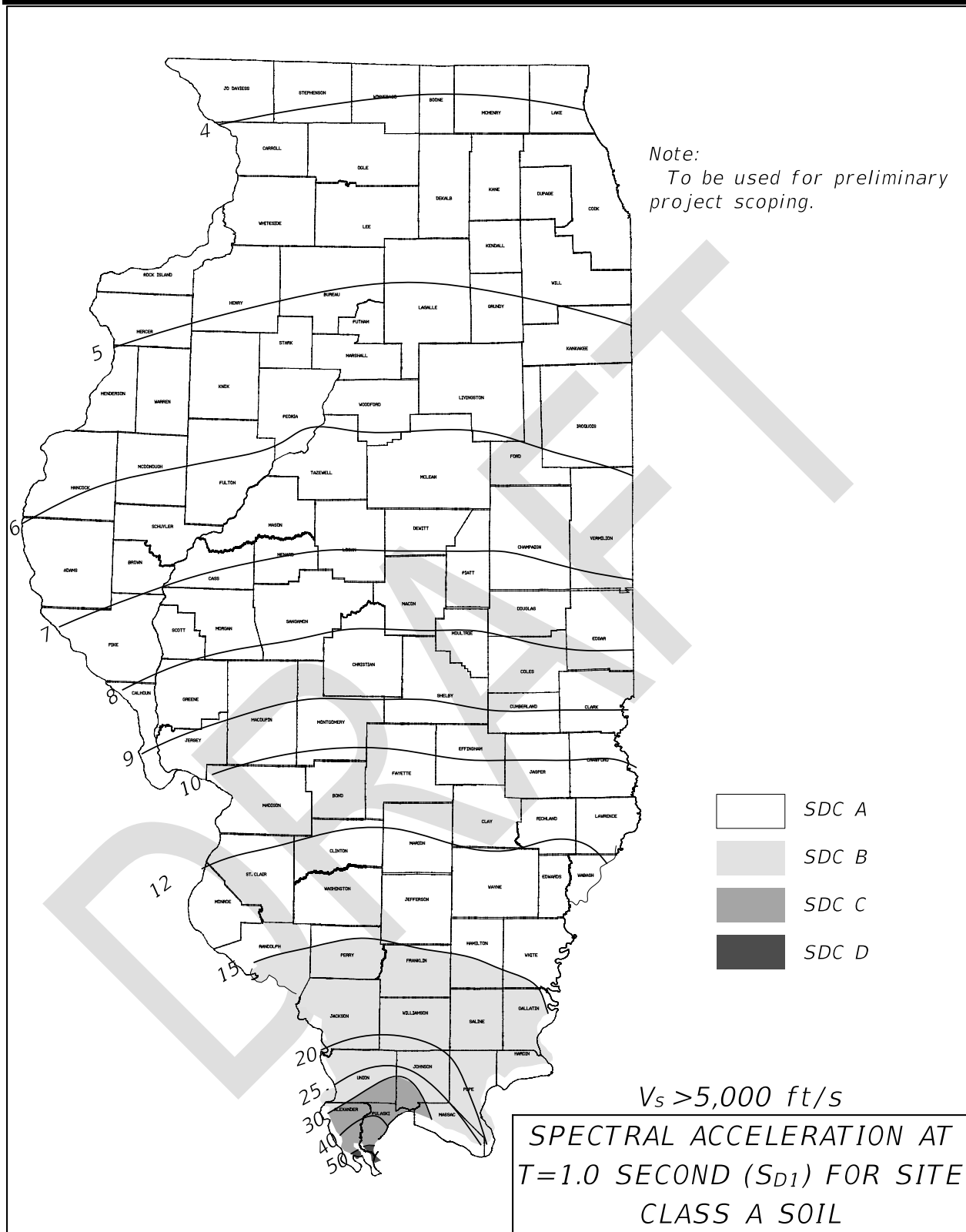

Figure 3.5-1

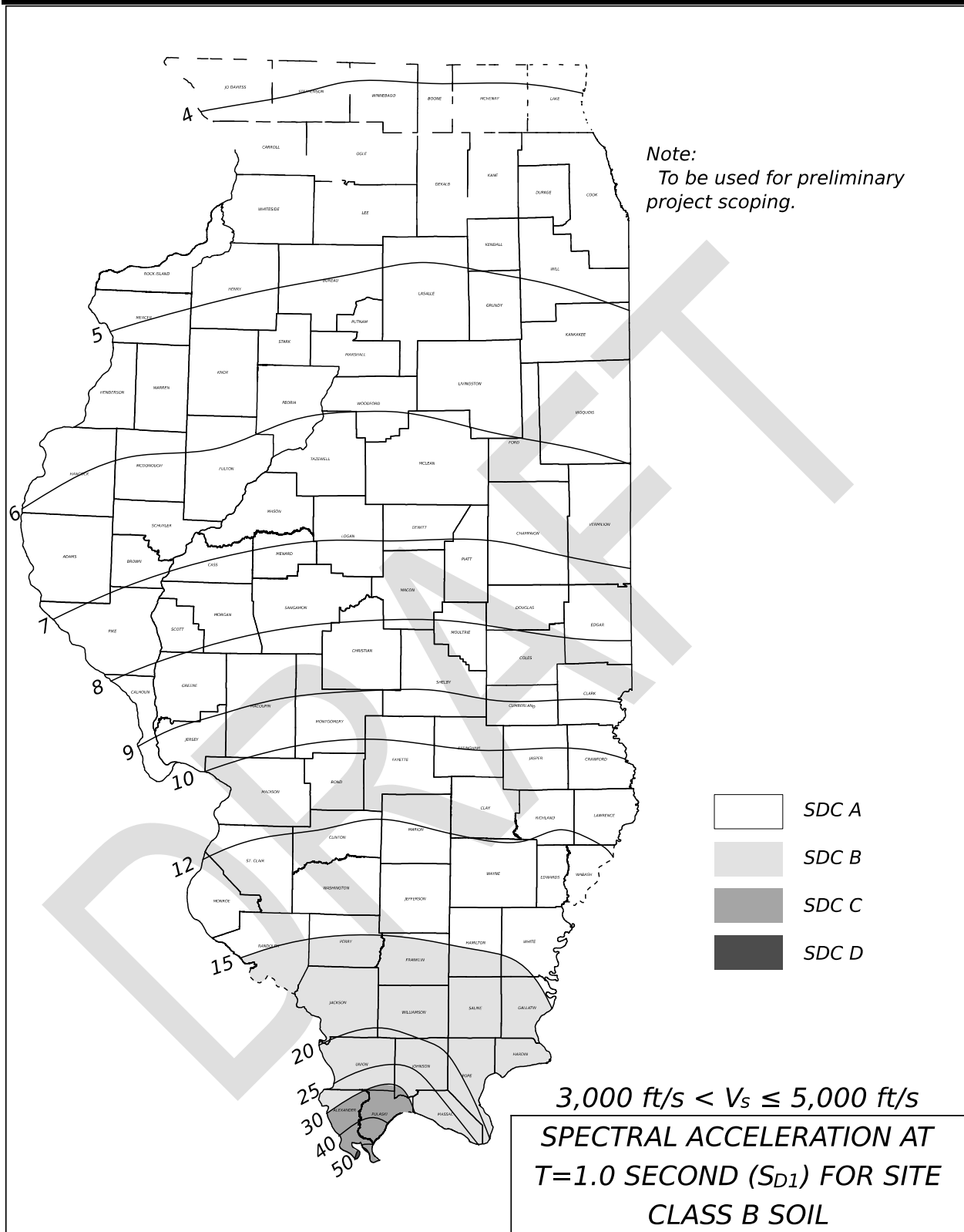

Figure 3.5-2

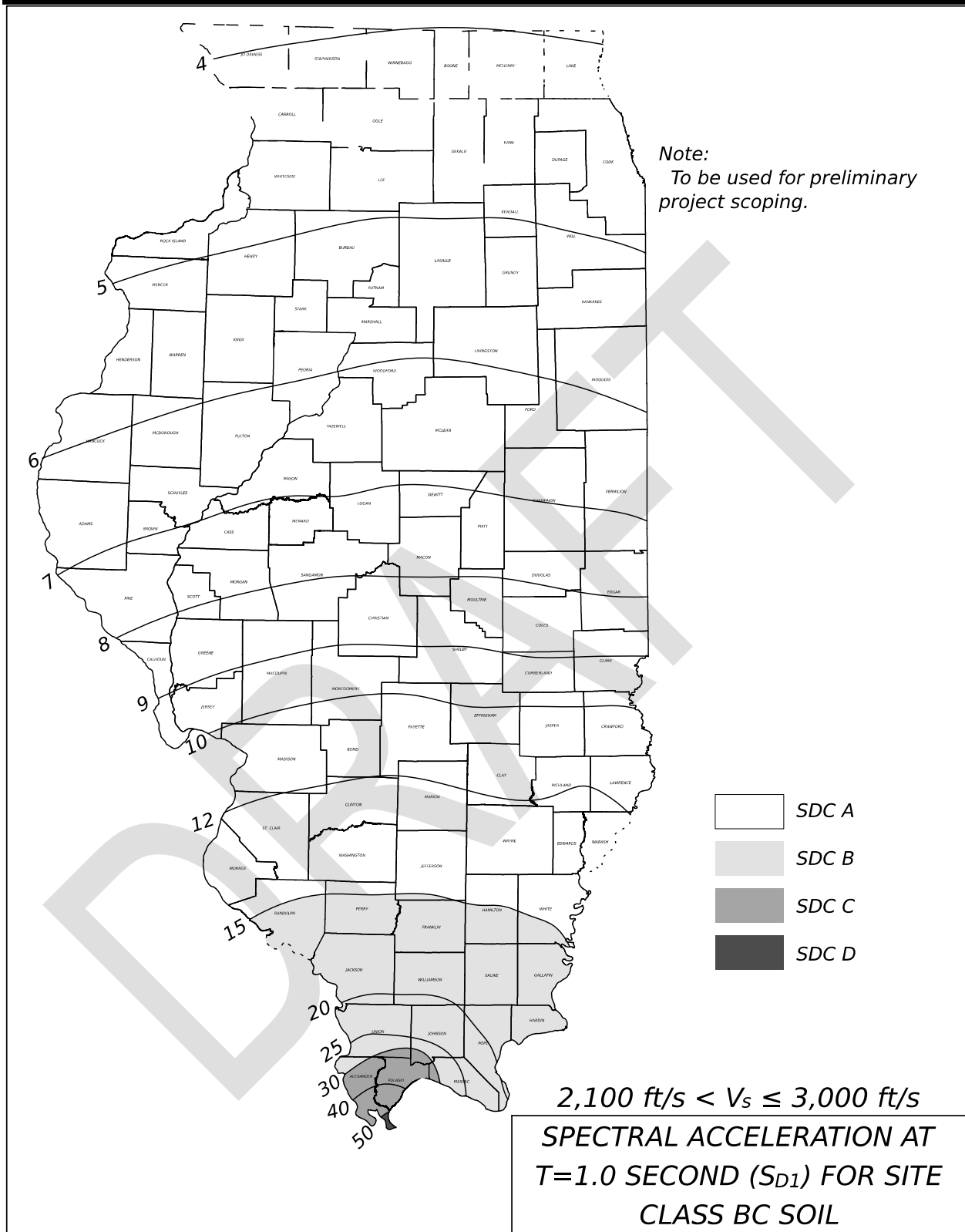

Figure 3.5-3

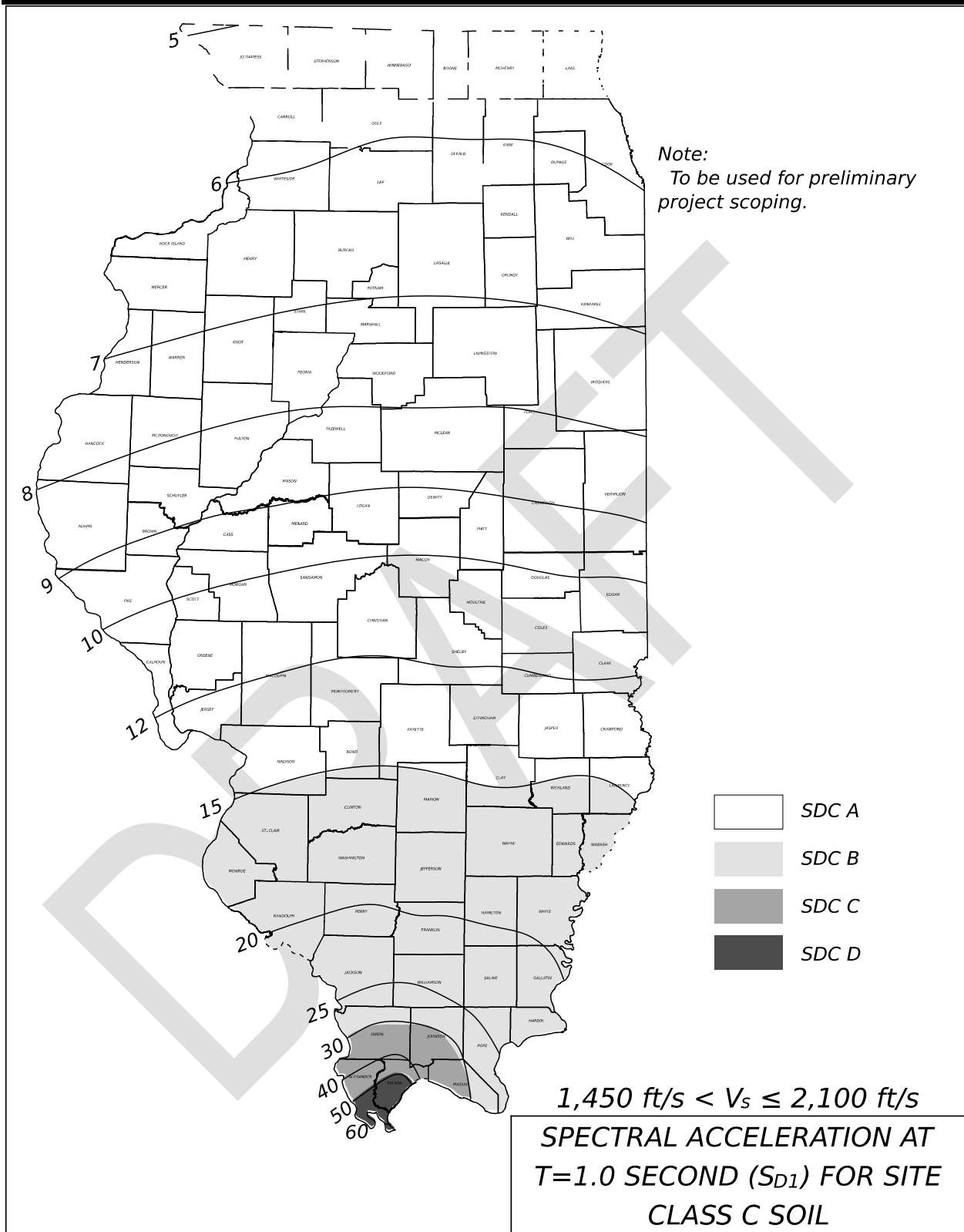

Figure 3.5-4

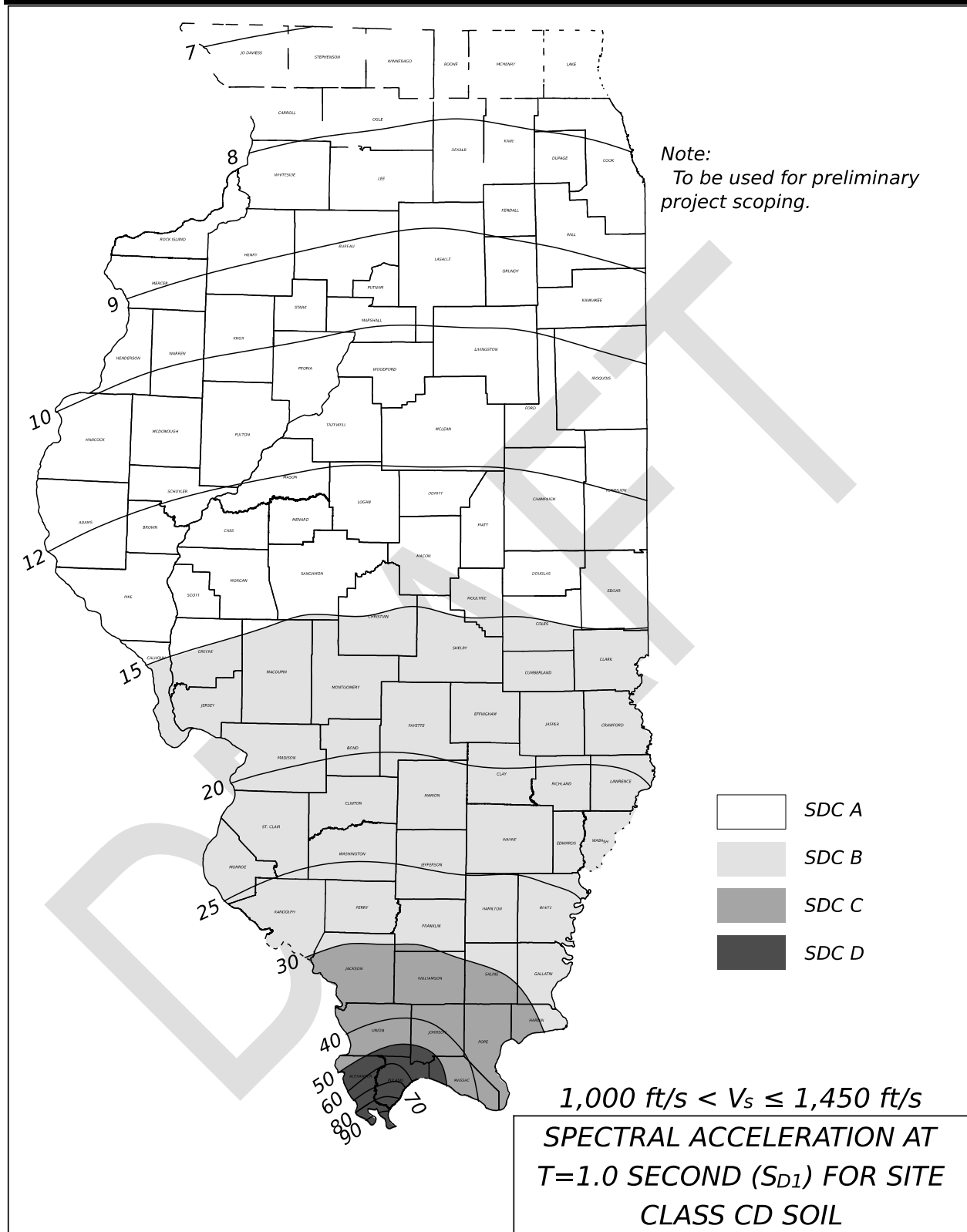

Figure 3.5-5



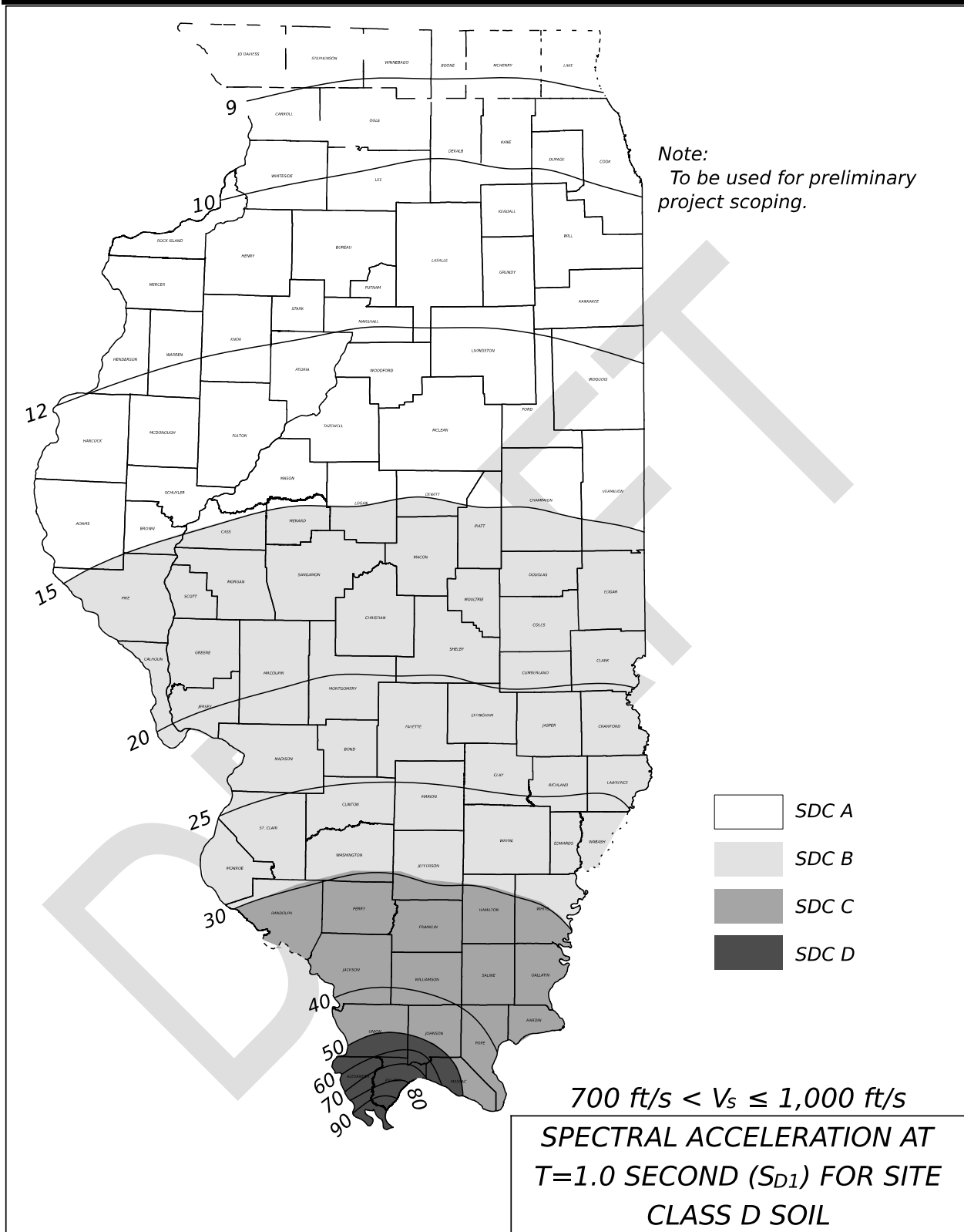

Figure 3.5-6

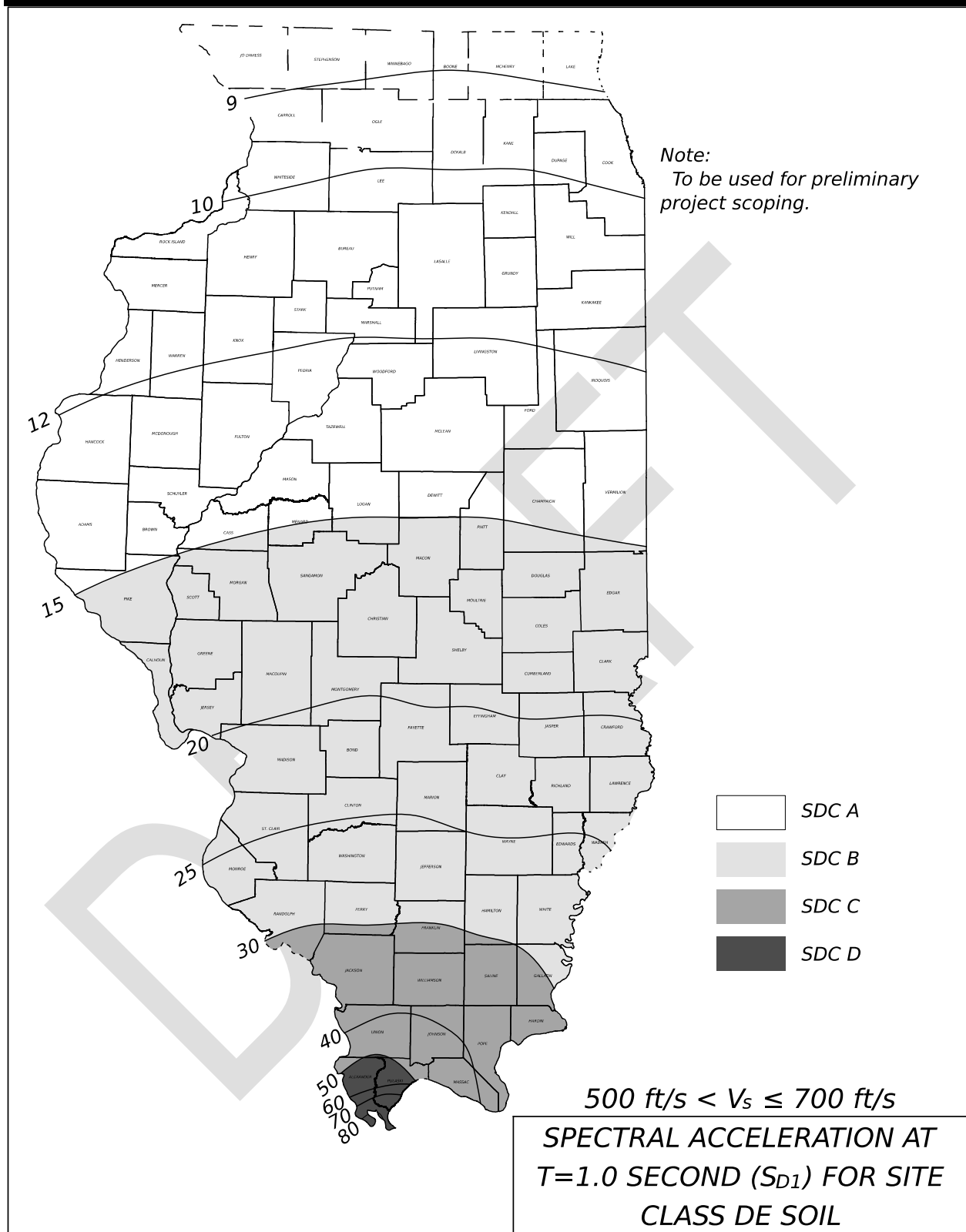

Figure 3.5-7

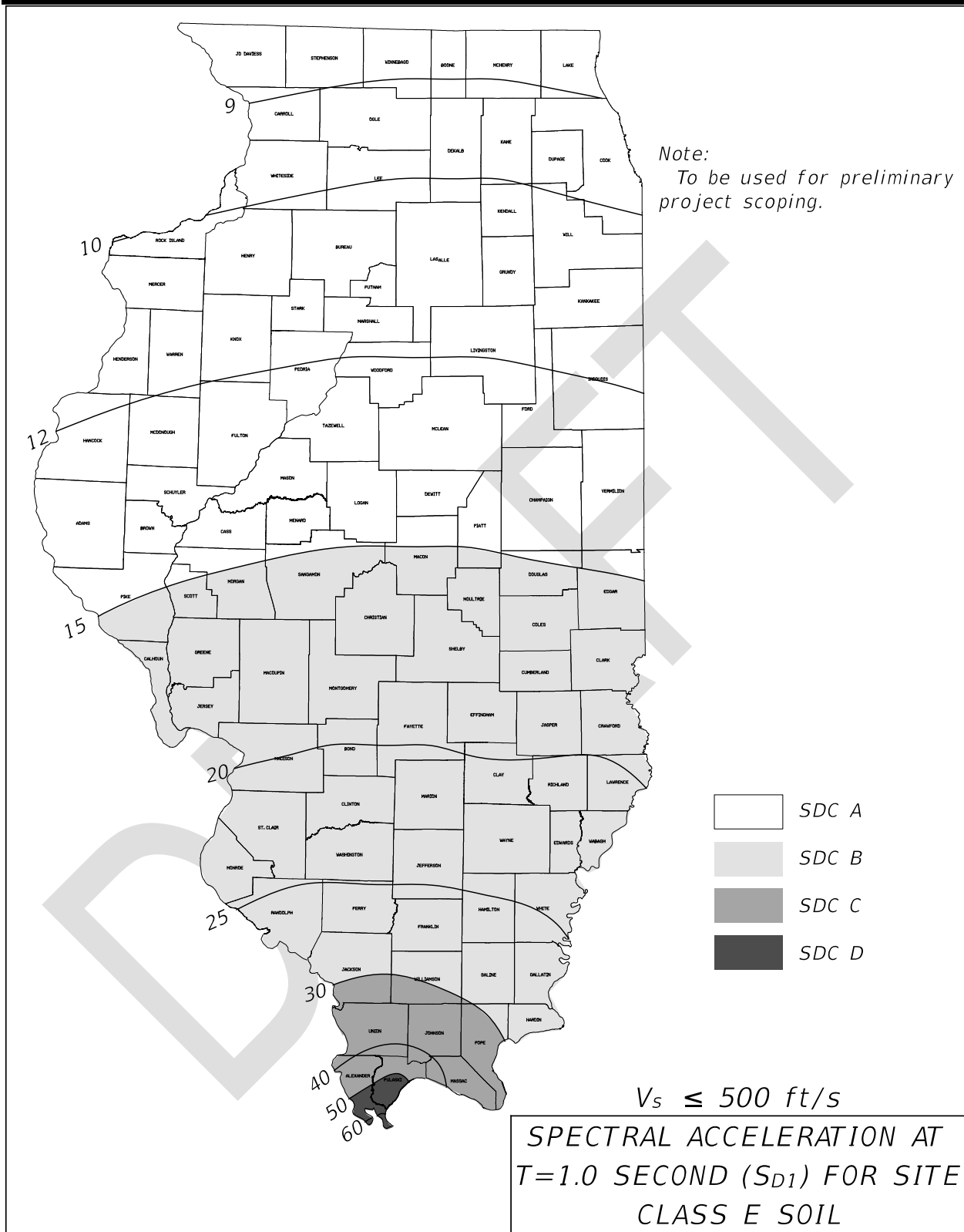

Figure 3.5-8

**3.7 Site-Specific Procedures**

As further discussed in Section 3.7.2, when required, site-specific hazard data shall be provided on the TSL plans for any data the designer will be required to utilize in design. This may include:

- Addition of vertical accelerations to the hazard (3.7.1, SM)
- A site-specific hazard spectrum, with or without vertical accelerations (3.7.2, SM)

**3.7.1 Vertical Accelerations**

As per Article 4.7.2 of the SGS, vertical accelerations are only required to be analyzed when the structure satisfies all three of the following criteria:

- Located in SDC D
- Located within 6.25 miles of an active fault with a mean moment magnitude of 6.0 or greater, or within 9.5 miles of an active fault with a mean moment magnitude of 7.0 or greater
- Bridge Operational Category of Critical or Recovery

To aid in this determination, Figure 3.7.1-1 of this document shows active fault lines in southern Illinois. This figure shows all faults in counties potentially located in SDC D. However, depending upon the site class at the bridge location, most of these locations will not also fall have accelerations consistent with SDC D, and structures at these locations will not require additional analysis.

Figure 3.7.1.-1 shows that, even within SDC D regions of the state, many bridge locations are also not within a proximity of an active fault meeting the above criteria. Even if they are within the proximity limits stated above, the mean moment magnitude of the earthquake still may not exceed the requirements above. It is therefore not likely that structures will require analysis for vertical acceleration. When it is suspected that a site may meet the criteria above, contact the Bureau of Bridges and Structures for further analysis considerations.

In the uncommon case where vertical acceleration is required, and a site-specific hazard spectrum as per Article 3.7.2 of this document is not required, the vertical accelerations may be

taken as two-thirds of the horizontal accelerations. The TSL plans shall state “Vertical Acceleration =  $2/3 * \text{Horizontal Acceleration}$ ” to alert designers of this requirement.

When a site-specific hazard spectrum is required as per Article 3.7.2 of this document, and design for vertical acceleration is required, the vertical acceleration hazard spectrum shall be determined from the site-specific analysis. In these cases, the vertical acceleration hazard spectrum shall be shown on the TSL plans.

DRAFT

Description: This map provides approximate locations of the southern Illinois Fault lines. Please consult Illinois State Geological Survey and other authoritative sources to validate when doing precise work with this data.

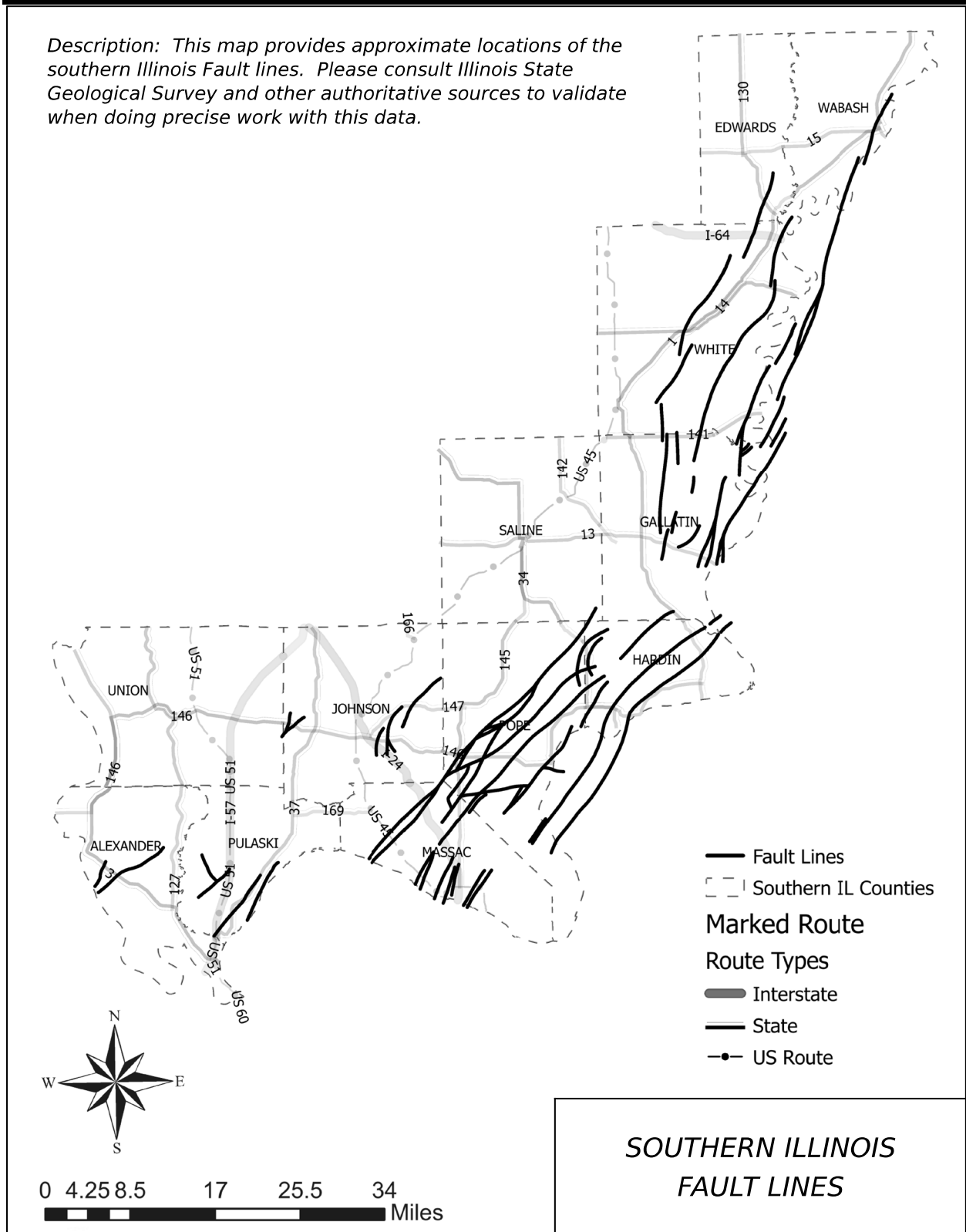

Figure 3.7.1-1

**3.7.2 Site-Specific Hazard Spectrum**

Site-specific hazard spectra are discussed in Article 3.7.3 of the SGS.

Site-specific hazard spectra are required for structures meeting all three of the following requirements:

- Bridge Operation Category is Critical
- SDC C or D
- Main spans of structure are arch, cable-stay, suspension, extradosed, or truss

A site-specific hazard spectrum is based upon earthquake data chosen by the geotechnical engineer. The design hazard is based on this data, in lieu of use of the 2023 AASHTO Seismic Hazard.

When required, the site-specific earthquake data is taken from the USGS website and is chosen based upon magnitude and proximity for a specific site. This data is included in the Structure Geotechnical Report. Contact the Bureau of Bridges and Structures for more information on selection of data and formulation of seismic criteria for a site-specific hazard.

Locations with geoseismic hazards, such as liquefaction triggering or lateral spread, require a different type of site-specific procedure. Even though the terminology “site-specific” is used in geoseismic analysis, the requirements are not the same. More information on site-specific procedures for geoseismic hazards are found in Article 3.8 of this Manual.

**3.8 Geoseismic Hazards****3.8.1 Applicability**

For all bridges and retaining walls, statements regarding geoseismic hazard evaluations such as liquefaction potential, lateral spreading, and slope instability shall be provided in the Structure Geotechnical Report. The potential for liquefaction triggering and other geoseismic effects shall be evaluated according to the requirements found in Article 6.2 of the Guide Specifications, as follows:

- There are no geoseismic foundation investigation requirements for SDC A (Article 6.2.3 SGS)
- For SDC B, C, and D, the potential for liquefaction, seismic-induced settlement, lateral spreading, slope instability, and increases in lateral earth pressure, all as a result of earthquake motion, shall be considered (Article 6.2.4 SGS). See Article 3.8.2 of this document. Kinematic and inertial effects from these hazards should be considered.

For culverts, geoseismic hazard evaluations such as liquefaction analysis are not required.

### *3.8.2 Liquefaction Analysis*

For each substructure unit, the necessity of a liquefaction analysis shall be independently investigated. A flowchart is provided in Figure 3.8.2-1 to aid in determining whether or not a liquefaction is required. It uses the following parameters to make that determination:

- Ground Acceleration Requirements for Liquefaction Analysis (3.8.2.1, SM)
- Groundwater Elevation Requirements for Liquefaction Analysis (3.8.2.2, SM)
- Soil Property Requirements for Liquefaction Analysis (3.8.2.3, SM)
- Atterberg Limit Requirements for Liquefaction Analysis (3.8.2.4, SM)

If the liquefaction analysis indicates that the factor of safety of liquefaction triggering is greater than or equal to 1.0 for all soil layers within the upper 60 feet of the geotechnical profile, no further consideration of liquefaction is necessary. If the analysis identifies soil layers with a factor of safety of liquefaction less than 1.0 within the upper 60 feet of the geotechnical profile, the potential effects of liquefaction on the performance of a structure shall be considered and/or ground modification to mitigate potential effects shall be investigated.

Liquefaction analysis procedures, and a worked example, are provided in Department's liquefaction design guide, found on the IDOT website. The Simplified Method described by Youd et al (2001) shall be used to estimate liquefaction triggering potential. The simplified method compares the resistance of a soil layer against liquefaction (CRR, cyclic resistance ratio) to the seismic demand on a soil layer (CSR, cyclic stress ratio) to estimate the FS of a given soil layer against triggering liquefaction. An Excel spreadsheet that performs these calculations has been



prepared to assist Geotechnical Engineers with conducting a liquefaction analysis and may be downloaded from IDOT's website.

Ground modification techniques to mitigate liquefaction triggering will be assessed by the Department on a case-by-case basis.

DRAFT

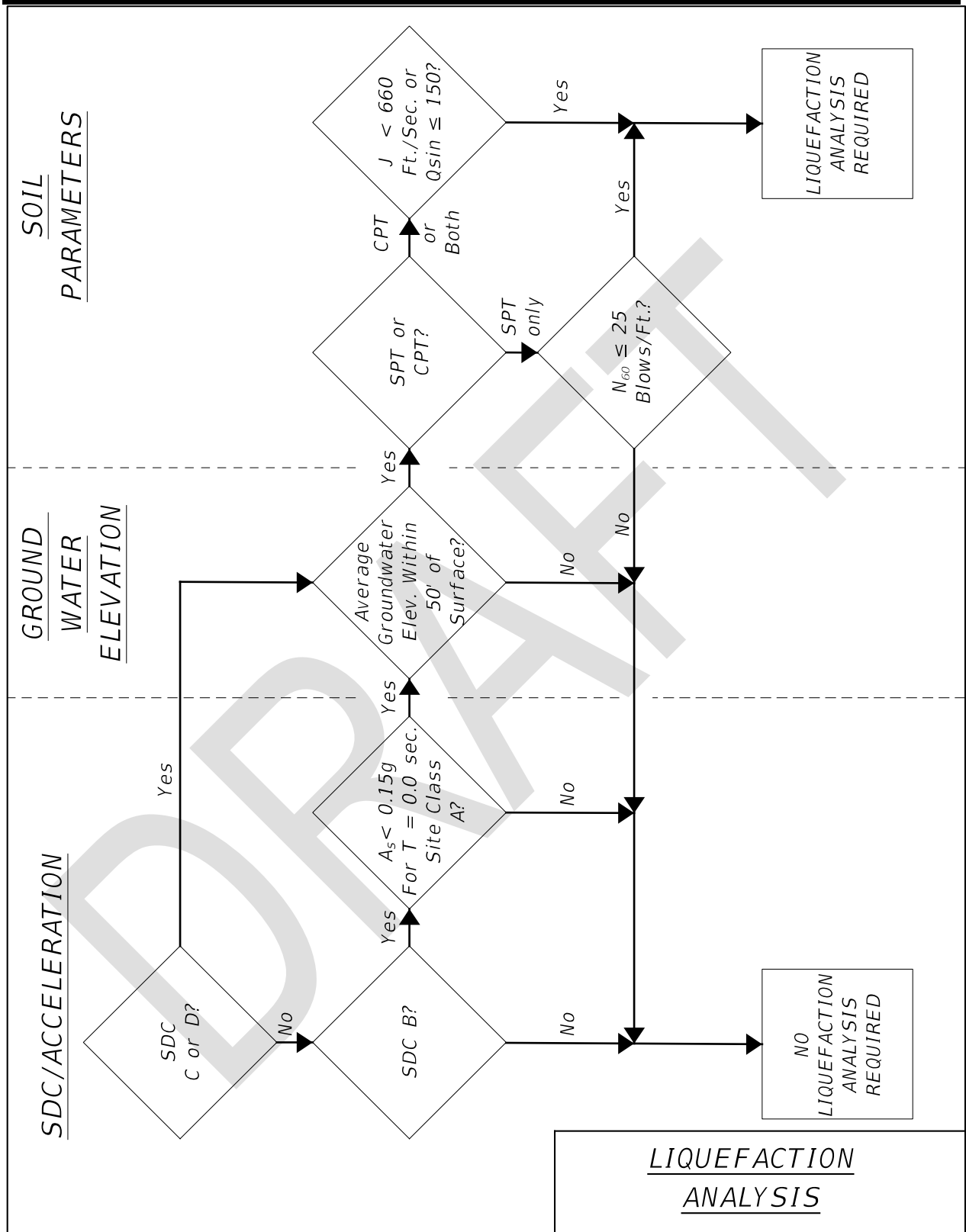

Figure 3.8.2-1

**3.8.2.1 Ground Acceleration Requirements for Liquefaction Analysis**

As per Article 6.8 of the SGS, liquefaction analysis shall be considered for all locations in SDC C and D.

For locations in SDC B, liquefaction analysis shall only be considered if the acceleration at zero-second period, for Site Class A, is greater than 0.15g for the specified location. This may be determined from the 2023 AASHTO Seismic Hazard, by running the webtool with the following parameters:

- Latitude and longitude of location
- Site Class A

If the resulting acceleration at 0.0 seconds exceeds 0.15g, then a liquefaction analysis should be considered for SDC B.

For locations in SDC A, liquefaction analysis is not required.

**3.8.2.2 Groundwater Elevation Requirements for Liquefaction Analysis**

For liquefaction to occur, groundwater must be present in the soil layers at the site.

Liquefaction analysis shall be considered if the groundwater level anticipated at the site is within 50 ft. of the ground surface elevation. The ground surface elevation shall be taken as the lower of the existing or proposed ground surface. The groundwater elevation used in the analysis shall be taken as the groundwater elevation for the site, as shown in the boring logs or as taken from other data.

**3.8.2.3 Soil Property Requirements for Liquefaction Analysis**

For liquefaction to occur, the seismic demand on the soil layers must exceed the capacity of the soils to withstand liquefaction. Some soils have sufficient capacity such that a liquefaction analysis will not be required.

When SPT is used in determining soil boring data, a liquefaction analysis shall be considered if the corrected standard blow count,  $N_{60}$ , is less than or equal to 25 blows/ft., a liquefaction analysis may be required. The corrected standard blow count shall be taken as the weighted average of the blow counts in the soil layers in the upper 75 ft. of the column.

When CPT is used in determining soil boring data, a liquefaction analysis shall be considered when one of the following two conditions is met:

- The tip resistance,  $q_{ciN}$ , is less than or equal to 150 in sand and non-plastic silt layers.
- The normalized shear wave velocity,  $v_s$ , is less than 660 ft. / sec. The normalized shear wave velocity shall be taken as the weighted average of the shear wave velocities in the upper 75 ft. of the column.

#### 3.8.2.4 Atterberg Limit Requirements for Liquefaction Analysis

Low plasticity silts and clays may experience pore-water pressure increases, softening, and strength loss during earthquake shaking similar to cohesionless soils. Fine-grained soils with a plasticity index (PI) less than 12 and water content ( $w_c$ ) to liquid limit (LL) ratio greater than 0.85 are considered potentially liquefiable and require liquefaction analysis.

Soil samples may not be available to make this determination. For example, when CPT is used in determining soil boring data, samples are not retained. When unavailable, the geotechnical engineer has the option of requesting Atterberg Limit testing, which may require new samples be taken from a new soil boring, or this requirement may be waived.

#### *3.8.3 Combination of Kinematic and Inertial Effects*

During a seismic event, the seismic loading potentially affects the bridge in two ways:

- Inertial effects, caused by shaking of the structure itself.
- Kinematic effects, caused by ground displacement adjacent to the structure. These are secondary effects such as lateral spreading or slope failure, wherein something adjacent to the structure moves, causing force effects on the structure.

These two effects do not typically occur at the same time. Maximum kinematic effects tend to occur later than maximum inertial effects. Therefore, combination of the maximum kinematic effects with the maximum inertial effects may be unrealistically conservative. The geotechnical report shall state when and how the kinematic effects should be considered by the structural and geotechnical engineers.

In lieu of more precise calculations, the following load combinations are generally considered in industry as a conservative baseline for consideration:

- 100% kinematic effects + 50% inertial effects
- 100% inertial effects

This load combination may be adjusted by the author of the SGR if refined analysis identifies that the two effects will not be considered concurrent. It should be noted that the costs incurred by using a higher load combination could be considerable.

DRAFT

DRAFT





# Section 4 Planning Structure Types

When planning structure types for structures in high-seismic design categories, the following shall be considered:

- Superstructure Types, Span Lengths, and Structure Length
- Abutment Types
- Pier Types
- Foundation Types

This section is organized first by SDC, then by the individual categories above.

When planning pier substructure types, considerations should be given to bridge regularity, especially with respect to relative stiffnesses of adjacent piers. While bridge regularity is not always possible to achieve, it is desirable both with respect to intensity of structural design calculations, and predictable behavior in a seismic event.

## 4.1 Planning Structure Types for SDC A and B

### 4.1.1 Superstructure Types, Span Lengths, and Structure Length for SDC A and B

Slab, steel beam, concrete beam, and deck beam superstructures are allowed, regardless of span length and structure length.

### 4.1.2 Abutment Types for SDC A and B

Abutments of any type may be used at any location. Where liquefaction triggering is a concern, spread footings shall not be used in soils susceptible to liquefaction triggering, unless the bottom of the footing is located below the maximum depth of liquefiable soil layers (6.3.3, SGS) or ground improvement techniques are employed to mitigate liquefaction.

### *4.1.3 Pier Types for SDC A and B*

With the exception of locations where liquefaction is a concern, there are no constraints on pier types in SDC A and B locations. Fixed and expansion bearings of any type may be used at any location.

Vertical ground settlement should be expected to occur following liquefaction triggering. Spread footings shall not be used in soils susceptible to liquefaction triggering, unless the bottom of the footing is located below the maximum depth of liquefiable soil layers (6.3.3, SGS) or ground improvement techniques are employed to mitigate liquefaction.

Bridge planners should note that use of piers with expansion bearings will may increase structure periods and therefore decrease applied loads.

### *4.1.4 Battered Piles for SDC A and B*

Use of battered piles on substructures is allowed in SDC A and B locations.

## **4.2 Planning Structure Types for SDC C**

### *4.2.1 Superstructure Types, Span Lengths, and Structure Length for SDC C*

#### 4.2.1.1 Slab, Steel Beam, or Deck Beam Superstructures for SDC C

Slab, steel beam, and deck beam superstructures are allowed, regardless of span length or structure length.

#### 4.2.1.2 PPC I, Bulb-T, and IL-beam Superstructures for SDC C

For single-span structures, PPC I, Bulb-T, and IL-beam superstructures are allowed for any span length. For multi-span structures, there are constraints on use of PPC I, Bulb-T, and IL-beam superstructures in SDC C locations. Use of PPC I, Bulb-T, and IL-beam superstructures is allowed in SDC C locations given the following parameters are met:

- Overall structure length  $\leq$  280 ft.

- Longest span length  $\leq$  120 ft.

#### *4.2.2 Abutment Types for SDC C*

Fixed and expansion abutments of any type may be used at any location. Battered piles at stub abutments may be considered, subject to the requirements given below.

Where liquefaction triggering is a concern, spread footings shall not be used in soils susceptible to liquefaction triggering, unless the bottom of the footing is located below the maximum depth of liquefiable soil layers (6.3.3, SGS) or ground improvement techniques are employed to mitigate liquefaction.

When liquefaction, lateral spreading, approach settlement, and/or downdrag hazards exist in SDC C, additional abutment modeling and detailing concerns may apply. This may include use of approach bents on piles, ground anchors at abutments, or ground improvement techniques such as aggregate columns or controlled stiffness columns. See Article 6.5 of this document for more information on abutment modeling and Article 8.x for abutment details that may alleviate these concerns.

#### *4.2.3 Pier Types for SDC C*

Fixed and expansion bearings of any type may be used at any location. Bridge planners should note that use of piers with expansion bearings will may increase structure periods and therefore decrease applied loads.

Spread footings shall not be used in soils susceptible to liquefaction triggering, unless the bottom of the footing is located below the maximum depth of liquefiable soil layers (6.3.3, SGS) or ground improvement techniques are employed to mitigate liquefaction.

#### *4.2.4 Battered Piles for SDC C*

Battered pile configurations introduce large amounts of stiffness while simultaneously having non-ductile connections. The use of battered piles may cause issues in design if their compatibility with the overall seismic performance is not properly considered. In addition, the high stiffness of

battered piles may increase seismic lateral earth pressure on the stem, and large axial and shear forces may develop where liquefaction, lateral spreading, or downdrag hazards exist.

For structures in SDC C locations, the effects of battered piles may result in difficulty of design. Therefore, use of battered piles is strongly discouraged, but may be allowed on a case-by-case basis. If the use of stub abutments is required in SDC C locations, alternate stub abutment details utilizing straight piles and geotechnical reinforcement may be used. See Article 8.x of this manual for more information.

### **4.3 Planning Structure Types for SDC D**

SGS Articles 4.1.2 and 4.1.3 provide guidance on stiffness balancing for structures in SDC D. The proportioning ratios in this section should be used whenever feasible.

#### ***4.3.1 Superstructure Types, Span Lengths, and Structure Length for SDC D***

##### **4.3.1.1 Slab, Steel Beam, or Deck Beam Superstructures for SDC D**

There are no constraints on use of slab, steel beam, or deck beam superstructure types in SDC D locations. Slab and deck beam superstructures are allowed, regardless of span length or structure length.

##### **4.3.1.2 PPC I, Bulb-T, and IL-beam Superstructures for SDC D**

The use of PPC I-, Bulb-T, and IL-beam superstructures are not allowed in SDC D.

#### ***4.3.2 Abutment Type for SDC D***

Integral abutments are inherently stiff by nature, and their use results in higher seismic loads. These higher seismic loads become prohibitively high in SDC D locations. Therefore, semi-integral abutments shall be used in lieu of integral abutments in SDC D locations where integral abutments would normally be used.

Use of stub abutments in SDC D is allowed in any location, given that battered piles are not used, as per the requirements in Article 4.3.4 of this document.

When liquefaction, lateral spreading, approach settlement, and/or downdrag hazards exist in SDC D, additional abutment modeling and detailing concerns may apply. This may include use of approach bents on piles and/or ground anchors at abutments. See Article 6.5 of this document for more information on abutment modeling and Article 8.x for abutment details that may alleviate these concerns.

#### ***4.3.3 Pier Types for SDC D***

With the exception of locations where liquefaction is a concern, there are no constraints on pier types in SDC D locations. Fixed and expansion piers of any type may be used at any location. Bridge planners should note that there are additional column height-to-diameter requirements for structures in SDC D. Because these may affect the hydraulic opening of the structure, the height-to-diameter requirements in Articles 8.8.2 and 8.11.2 of this document should be considered in the planning process.

Where liquefaction triggering is a concern, spread footings shall not be used in soils susceptible to liquefaction triggering, unless the bottom of the footing is located below the maximum depth of liquefiable soil layers (6.3.3, SGS) or ground improvement techniques are employed to mitigate liquefaction.

#### ***4.3.4 Battered Piles for SDC D***

Battered pile configurations introduce large amounts of stiffness while simultaneously having non-ductile connections. The use of battered piles may cause issues in design if their compatibility with the overall seismic performance is not properly considered. In addition, the high stiffness of battered piles may increase seismic lateral earth pressure on the stem, and large axial and shear forces may develop where liquefaction, lateral spreading, or downdrag hazards exist.

For structures in SDC D locations, the effects of battered piles will result in difficulty of design. Therefore, use of battered piles is not allowed. If the use of stub abutments is required in SDC D locations, alternate stub abutment details utilizing straight piles and geotechnical reinforcement may be used. See Article 8.x of this manual for more information.

DRAFT

# **Section 5 Analysis Procedures**

Reserved.

DRAFT

DRAFT



# **Section 6 Modeling Assumptions**

Reserved.

DRAFT

DRAFT

# Section 7 Design Requirements

Reserved.

DRAFT

DRAFT

# Section 8 Plan Detail Requirements

The seismic detailing requirements found in this section are consistent with a Type 1 ERS, with an essentially elastic superstructure and a ductile substructure. See Article 1.6. If a Type 3 ERS is required for isolation design, some of the requirements in this section may be reduced if necessary. If a Type 3 ERS is used, and some requirements in this section are found to be inapplicable, please contact the Bureau of Bridges and Structures for additional guidance.

As the SDC of the structure increases, the detailing requirements become more stringent. Bridges in SDC A have the lowest detailing requirements, only requiring superstructure-to-substructure connection designs, support length checks, and some reinforcement details. Bridges in SDC B have more seismic detailing requirements than structures in SDC A, but still have significantly less requirements than those in SDC C and D. This section will outline what seismic details are required for each SDC. This section also provides minimum force requirements for connections.

**8.1 Superstructure-to-Substructure Connections**

Superstructure-to-substructure connections consist of bearings, dowel rods, or monolithic diaphragms. The following is a list of superstructure-to-substructure connection types, and their components to be considered in seismic design:

Connection Type	Bridge Type and Location on Bridge	Connection Components Requiring Design
Type I, II, and III Elastomeric Bearings	Slab-on-Beam Bridge Bearings, Slab Bridge Bearings	Bottom flange to sole plate bolts (steel beams) Bottom flange to sole plate pintles (precast prestressed concrete beams) Slab to sole plate studs and bolts (slab bridges) Anchor bolt to concrete cap
High-Load Multi-Rotational Bearings and Isolation Bearings	Slab-on-Beam Bridge Bearings	Bottom flange to sole plate bolts Anchor bolt to concrete cap
Low-Profile Steel Fixed Bearings	Slab-on-Beam Bridge Bearings	Bottom flange to sole plate weld Sole plate to masonry plate pintle Anchor bolt to concrete cap
Dowel Rods and Fabric Bearing Pads	PPC Beam Bridges at Non-Expansion Piers, Deck Beam Bridges	Dowel Rods
Monolithic Diaphragms	Integral Abutment Bridge Abutments, Slab Bridge Abutments and Piers	None

*Table 8.1-1*

Depending upon the component and seismic design criteria, the design force for these connection components is one of following two reactions:

1. Full seismic lateral reaction, taken as the seismic acceleration coefficient times the Extreme Event I limit state reaction at the component location, but not less than 0.2 times the dead load reaction.

This design force is used when a component is assumed to remain elastic in seismic event. The lower acceleration coefficient limit of 0.2 is taken as a simplification of the required design forces for SDC A found in Article 4.6 of the SGS.

2. Notional seismic lateral reaction, taken as  $0.2 * (R_{DC} + R_{DW})$ , where  $R_{DC}$  is the reaction due to dead load and  $R_{DW}$  is the reaction due to wearing surface load.  $R_{DW}$  may be taken as zero at the discretion of the designer.

This design force is used when component is not assumed to remain elastic in seismic event. Article 7.6.4 of the SGS requires this notional force to be taken as  $0.4 * (R_{DC} + R_{DW})$ . However, IDOT has performed physical tests on elastomeric bearings, that resulted in satisfactory bearing performance and a notional design coefficient of 0.2. This value also conveniently aligns with the minimum full seismic lateral reaction found in (1) above. See Article 3.7.3 of the Bridge Manual.

### **8.1.1 Type I, II, and III Elastomeric Bearings**

Standard details for Type I, II, and III elastomeric bearings are found in Article 3.7.4 of the Bridge Manual.

Type I elastomeric bearings are preferred over Type II and III elastomeric bearings, for the following reasons:

- The behavior of Type I elastomeric bearings in a seismic event is more predictable than that of Type II or III elastomeric bearings, due to the simplicity of the details of a Type I elastomeric bearing.
- For smaller earthquakes, Type I bearings have an automatic restoring/recentering force and will therefore return to their original position in the absence of drift.
- Due to the positive connections between the elastomer, bearing plates, and bottom flanges, beams cannot unseat from Type I bearings. With Type II and III elastomeric

bearings, the presence of the PTFE sliding surface precludes a positive connection, and the beam is prone to unseating from the bearing in a seismic event.

- Type I elastomeric bearings are lower in cost than Type II and III elastomeric bearings.

For the reasons above, use of Type II or III elastomeric bearings is discouraged in SDC B, C, and D.

For bridges in SDC B, C, or D, when a Type II or III elastomeric bearing is required as per the standard design tables found in Article 3.7.4 of the Bridge Manual, designers should attempt using a larger/taller Type I bearing instead. There is overlap between the Type I, and Type II and III bearing selection charts, allowing a substitution to be made from a Type II or III bearing to a Type I bearing in some cases.

If simple substitution to Type I bearings from Type II or III bearings is not possible using the standard design charts, a job-specific bearing may be designed to facilitate use of a Type I elastomeric bearing. This may consist of a bearing of a larger footprint. Bearings with elastomer footprints of up to 24" x 24" are able to be tested by IDOT’s Central Bureau of Materials without cutting the bearing. If a bearing larger than 24" x 24" is required, designers should consider use of a dual bearing consisting of two smaller bearings side-by-side under the same beam end, in lieu of one large bearing.

Despite the preference of their usage, there may be situations where use of a larger Type I elastomeric bearing still may not be possible due to design constraints or geometric concerns. When this is the case, a Type II or III elastomeric bearings may be used. The unseating of beams from Type II or Type III elastomeric bearings is not seen as being as severe as the unseating of a beam from an abutment cap. Emergency vehicles will still be able to traverse the bridge, satisfying the requirements of the performance category.

Components of elastomeric bearings shall be designed using the following design forces:

Component	Design Force
Bottom flange to sole plate bolts	Seismic Acceleration * Extreme Event I limit state reaction
Elastomer vulcanization to steel plates	None
Anchor bolts to concrete cap	0.2 * (R <sub>DC</sub> + R <sub>DW</sub> )



Table 8.1.1-1

**8.1.2 HLMR Bearings and Isolation Bearings**

HLMR and isolation bearings have three different connections:

- Bottom-flange-to-bearing connections.
- Internal bearing connections, which are connections within the bearing itself, such as the connection between a guide rail and a sole plate, or between a piston and top plate in a pot bearing.
- Bearing-to-substructure-cap connections.

Connections involving high load multi-rotational and isolation bearings shall be designed using the following design forces:

Connection	Design Force
Bottom flange to bearing bolts	Seismic Acceleration * Extreme Event I limit state reaction
Internal (design will be performed by bearing supplier)	Seismic Acceleration * Extreme Event I limit state reaction
Anchor bolts to concrete substructure cap	0.2 * (R <sub>DC</sub> + R <sub>DW</sub> )

Table 8.1.2-1

When HLMR or isolation bearings are required, the design plans shall show the required lateral seismic design force necessary to design the bearing internal connections. The design of internal connections is the responsibility of the proprietary bearing designer, and the resulting internal connections shown on the bearing shop drawings. See Article 3.7.5 of the Bridge Manual and Guide Bridge Special Provision 12 for more information on HLMR bearings.

**8.1.3 Low-Profile Fixed Bearings**

With the exception of bearings to be encased in concrete (e.g. at integral abutments), components of low-profile steel bearings shall be designed using the following design forces:

Connection	Design Force
------------	--------------

Bottom flange to sole plate weld	Seismic Acceleration * Extreme Event I limit state reaction
Sole plate to masonry plate pintle	Seismic Acceleration * Extreme Event I limit state reaction
Anchor bolt to concrete cap	0.2 * (DC + DW) Reaction

*Table 8.1.3-1*

**8.1.4 Bearing Layouts for Substructures with Expansion Bearings in SDC C and D**

Figure 8.1.4-1 shows schematics of bearing layouts for fixed and expansion substructure units in SDC C and D. These layouts differ from typical bearing layouts in that only the two bearings closest to the stage construction line are fixed to the substructure units. This allows for maximum superstructure movement in a seismic event, while still allowing the superstructure to remain fixed to the substructure during typical service loads.

The fixed bearings are placed closest to the centroid of the substructure unit to prevent torsional loads on the pier during a seismic event. This has the added benefit of limiting thermal loads in the lateral direction, while still allowing for some fixity to prevent superstructure walking during the deck pour.

When this bearing layout is used, shear blocks shall be provided at the ends of abutments and piers to prevent excessive lateral drifts. See Article 8.3 for more information on the design of shear blocks.

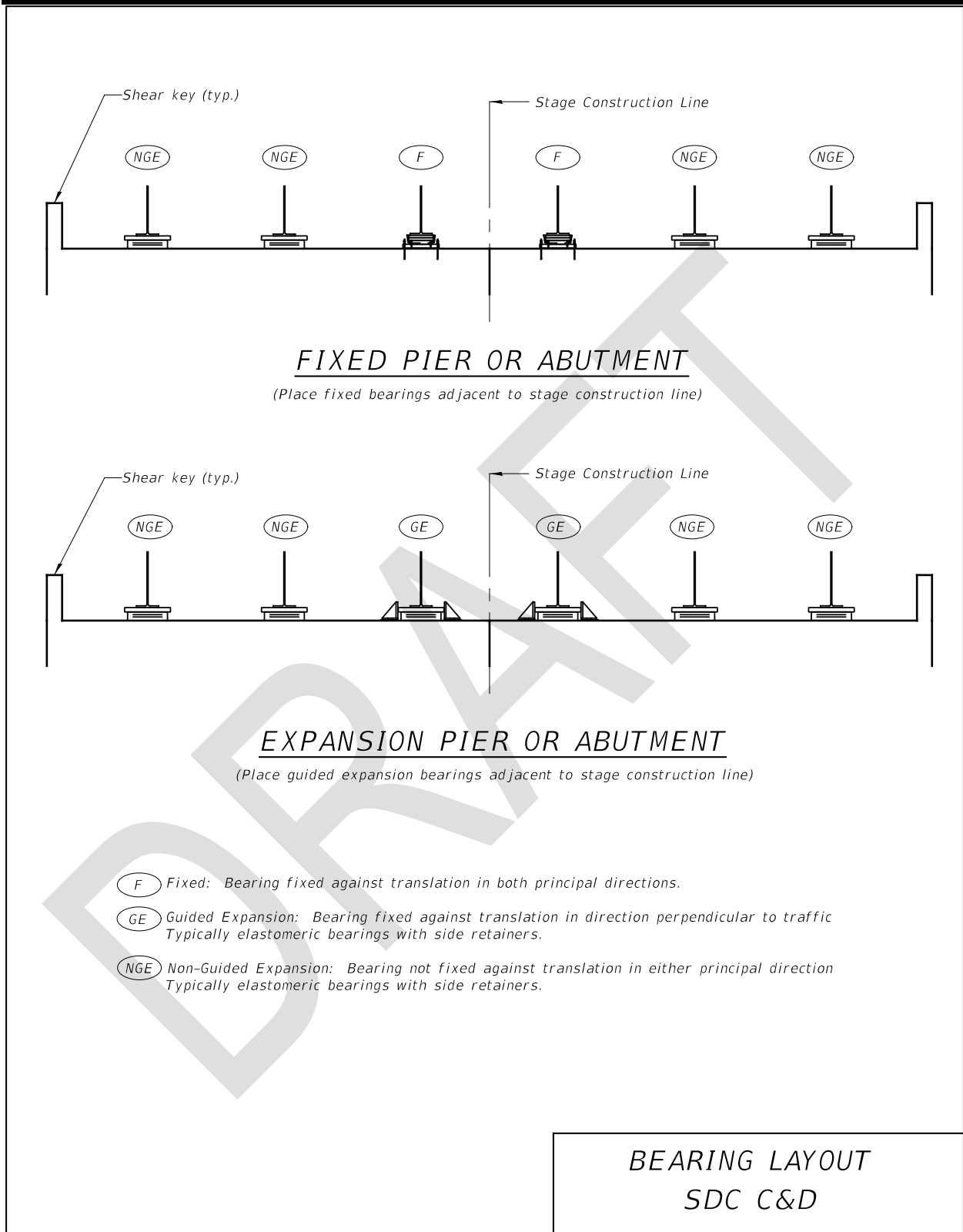

Figure 8.1.4-1

**8.1.5 Connections for Concrete Drop Diaphragms at Piers Fixed against Expansion for Precast Prestressed Beam Superstructures**

Piers fixed against expansion on bridges with precast prestressed beams utilize concrete drop diaphragms, as shown in Section 3.4.10 of the Bridge Manual. This section provides details for both fixed and pinned connections at piers fixed against expansion.

For bridges in SDC A, details for the number and location of dowel bars are found in Figure 3.4.10-4 of the Bridge Manual. The formula given in that figure is repeated here:

$$N = \frac{1}{2} \left[ \frac{0.2DL}{28.3S} - 2 \right] \quad (\text{Eq. 8.1.5-1})$$

Where:

- N = number of dowel bars in one line of dowels between beams
- DL = sum of unfactored dead load reactions at support (k)
- S = number of beam spaces

This formula provides a number of dowel bars that will satisfy a notional lateral seismic force of 0.2 times the dead load reaction at the pier.

For bridges in SDC B, C, and D, 0.2DL is replaced with the seismic acceleration times the factored Extreme Event I reaction:

$$N = \frac{1}{2} \left[ \frac{S_a R_{EEI}}{28.3S} - 2 \right] \quad (\text{Eq. 8.1.5-2})$$

Where:

- N = number of dowel bars in one line of dowels between beams
- $S_a$  = seismic acceleration coefficient (g), not to be taken as less than 0.2
- $R_{EEI}$  = sum of factored Extreme Event I reactions at support (k)
- S = number of beam spaces

Connection	Design Force
Dowel connection between concrete drop diaphragm and concrete pier cap (SDC A)	0.2 * (R <sub>DC</sub> + R <sub>DW</sub> ) (See Eq. 8.1.5-1 above)
Dowel connection between concrete drop diaphragm and concrete pier cap (SDC B, C, and D)	Seismic Acceleration * Extreme Event I limit state reaction (See Eq. 8.1.5-2 above)

*Table 8.1.5-1*

The dowel bar details in Article 3.4.10 of the Bridge Manual illustrates a fixed connection between the superstructure and substructure. When a pinned connection is required, the dowel details must be altered. Article 8.5 of this document gives seismic details for concrete drop diaphragms at piers for pinned connections.

**8.1.6 Connections for Deck Beam Superstructures**

There are no seismic detailing requirements for anchor rods for connections of deck beams to cap elements. Standard details for dowel connections have shear capacities far in excess of the seismic loads applied to them, allowing these connections to function as longitudinal restrainers.

Connection	Design Force
Dowel connection between concrete deck beam and substructure unit (SDC A, B, C, and D)	None

*Table 8.1.6-1*

**8.1.7 Connections for Monolithic Diaphragms at Integral Abutments**

Article 8.13.4 of the Guide Specifications gives requirements for detailing concrete joints connecting columns to superstructures. These provisions use the term “integral” to describe the connections. An “integral bent cap” is one where the columns are connected to a bent cap, which is integral with the superstructure (as opposed to a “drop bent cap”). Integral abutments are generally similar, in that the abutment diaphragm is integral with the superstructure and supported on piles. Where piles are not pinned and develop a full or partial moment fixity into the abutment diaphragm, Article 8.13.4 of the Guide Specifications shall also apply.

At integral abutments, the bonded construction joint with reinforcement extending across the interface between the concrete pile cap and the concrete diaphragm may be considered to be monolithic. The reinforcement extending across the interface between the concrete pile cap and the concrete diaphragm need not be designed or verified.

Connection	Design Force
Monolithic-type connection at integral abutment (SDC A, B, C, and D)	None

*Table 8.1.7-1*

**8.1.8 Fixed and Pinned Connections for Slab Bridges to Piers**

Slab bridges typically are short in length and have very stiff superstructures. This, in combination with fixed substructure units, may result in structures with low periods and high seismic demands. Any additional flexibility in these types of structures will be beneficial when performing the seismic analysis. One method of adding to flexibility to slab bridge structures in the longitudinal direction is to provide pinned connections at pier locations.

Figure 8.1.8-1 shows two different connections for slab bridge superstructures at piers. Designers may use either fixed or pinned connections in order to better optimize designs.

For fixed and pinned connections, vertical reinforcement connecting the slab superstructure to the pier shall be designed for the full seismic acceleration. Joint shear capacity shall be verified in design.

Due to the connections being assumed to remain monolithic in a seismic event, a concrete slab for a slab bridge superstructure utilizing a monolithic fixed connection shall be capacity-protected against the pier connection force. The capacity-protected elements include the connection from the pier cap to the slab, and the slab itself. See Article 7.8 of this document for more information.

Component	Design Force
Monolithic-type connection (fixed)	Seismic Acceleration * Extreme Event I limit state reaction
Pinned connection	Seismic Acceleration * Extreme Event I limit state reaction

*Table 8.1.8-1*

DRAFT

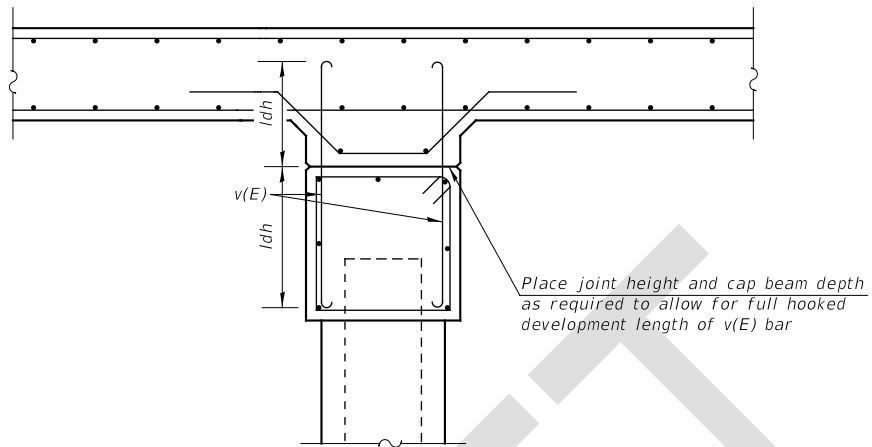

SLAB BRIDGE SUPERSTRUCTURE - FIXED CONNECTION TO PIER

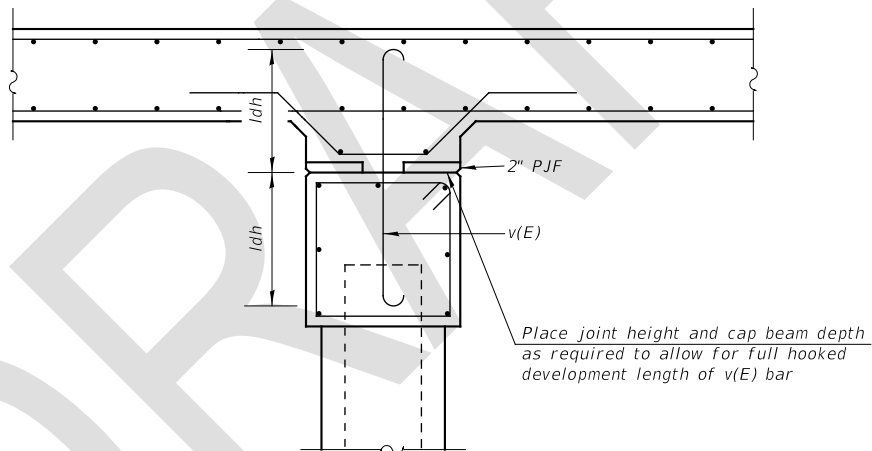

SLAB BRIDGE SUPERSTRUCTURE - PINNED CONNECTION TO PIER

SLAB BRIDGE PIER CONNECTIONS FIXED & PINNED

Figure 8.1.8-1



**8.2 Support Lengths**

Support lengths in the longitudinal direction are defined as the distance from the extreme edge of a superstructure element to the extreme edge of a substructure element upon which the superstructure element is located, measured along the centerline of the superstructure element. Support lengths in the transverse direction are defined as the distance from the centerline of a superstructure element to the transverse edge of the substructure element upon which it is located, measured perpendicular to the superstructure element. As per Article 4.12 of the SGS, support lengths are required to prevent superstructures from unseating from their respective substructures. Support lengths are measured in the global longitudinal and transverse directions of the structure.

Minimum support lengths are required for Seismic Categories A, B, C, and D.

Minimum support lengths,  $N$ , in the longitudinal direction, shall be calculated using the equations found in Articles 4.12.2 and 4.12.3 of the SGS. To satisfy the minimum value for  $N$  in this Article, the overall seat width shall be larger than  $N$  by an amount equal to movements due to prestress shortening, creep, shrinkage, and thermal expansion and contraction.

When there are no shear keys present, minimum support lengths,  $N$ , in the transverse direction, shall be calculated using the equations found in Articles 4.12.3 of the SGS. The formulas in Article 4.12.2 of the SGS are empirical and are based partially upon pier height and pier rotation. For bridges with no or small support skews, this effect is primarily in the longitudinal direction and is not applicable in the transverse direction. The formulas in Article 4.12.3 are based upon actual calculated seismic displacements, with a 24 in. minimum applied. These formulas are accurate in the transverse direction, and may result in smaller support lengths in that direction.

Concrete shear keys may be used at substructure units in lieu of support lengths in the transverse direction. See Article 8.3 of this document for more information.

For beam-on-slab bridges, support lengths may be taken as the distance from the free edge of a concrete pile cap to the extreme dimension of the bottom flange of the exterior beam. See Figure 8.2-1.

For abutments for slab bridges with elastomeric bearings, only the longitudinal support length need be provided at abutments. The superstructure may be assumed to not be able to unseat in the transverse direction, and the support length need not be provided in this direction.

For integral abutments, semi-integral abutments, or substructure units for slab bridges wherein the superstructure-to-substructure connection is a bonded concrete joint, support lengths are not required. Bonded construction joints may be assumed to be monolithic in a seismic event, making unseating impossible. Semi-integral abutments similarly cannot unseat due to the continuous details between the bridge superstructure and the approach slab.

For deck beam bridges, support lengths are not required. Standard anchor rods used to connect deck beams to substructure units provide a resistance greater than that required for shear failure, to the extent that they may be considered restrainers as per Article 4.13 of the SGS.

Support lengths in the longitudinal direction for continuous beams over piers need not be evaluated. Prestressed precast concrete beams utilizing standard IDOT continuity diaphragms are considered to be continuous. Therefore, support lengths in the longitudinal direction at piers for PPC beams are not required to be analyzed.

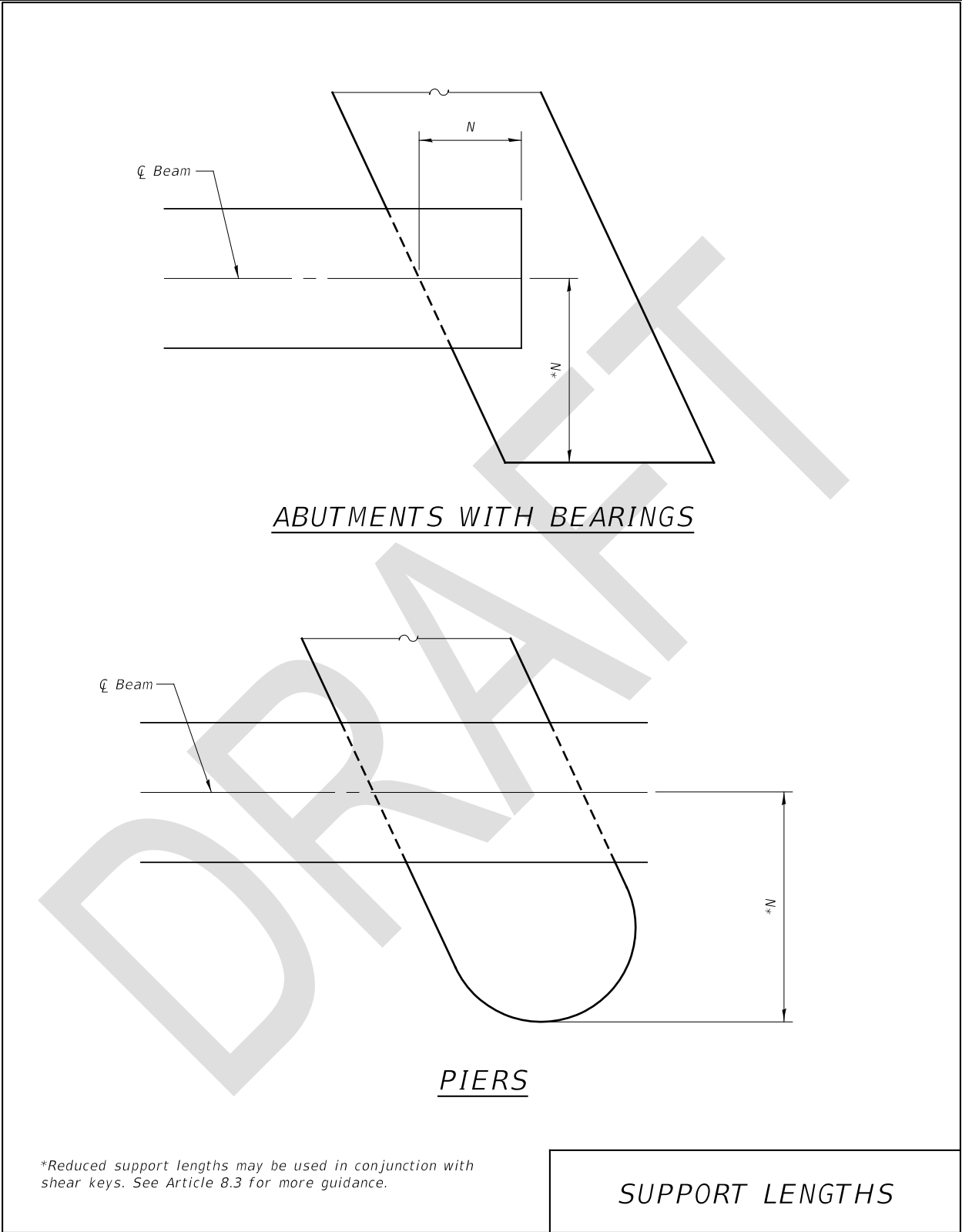

Figure 8.2-1

### 8.3 Concrete Shear Keys

Concrete shear keys are vertical blocks of concrete placed at the outside transverse edges of substructure units. The intent of concrete shear keys is to prevent the superstructure from unseating in the transverse direction, in the event of excessive drift in a seismic event. Concrete shear keys also prevent bridges from excessively “walking” over repeated loading. However, their design should be dependent on the most extreme loading they will experience i.e. the seismic loading.

If the support lengths prescribed in 8.2 are provided, structures in SDC A, B, and C do not require concrete shear keys at abutments or piers.

For structures in SDC C and D and structures in SDC B with skews exceeding 20 degrees, concrete shear keys shall be added to all substructure units to prevent unseating in the event of large residual drifts. These shear keys will be redundant in most cases, as the support lengths prescribed by the SGS will be sufficient. However, time history models have shown that bridges in Illinois with large skews and jointed abutments may exhibit more drift in the transverse direction than that allowed by the code. Therefore, to be conservative, shear keys are required at all substructure units for bridges in SDC C and D and substructure units in SDC B for bridges with skews exceeding 20 degrees.

The design of concrete shear keys is based upon the requirements in Articles 4.14 and 5.2.4.2 of the SGS::

$$V_{ok} = 1.5V_n$$

Where:

$V_{ok}$  = overstrength shear key capacity used in assessing the load path to adjacent capacity-protected members. For SDC B, C, and D, the overstrength shear key capacity should be verified against the sum of the shear capacities of the piles, columns, or shafts connecting to the substructure cap to ensure the substructure is capacity protected against the shear key (k)

$V_n$  = nominal interface shear capacity of shear key, as determined by Article 5.7.4 of the AASHTO LRFD Bridge Design Specifications (k), using the nominal material

properties and interface surface conditions. When calculating the concrete interface shear capacity of the shear key, the entire length and width of the shear key may be assumed to be effective in resisting the applied seismic shear. When calculating the steel reinforcement interface shear capacity, all vertical bars extending through the shear key into the abutment pile cap may be used. This reinforcement may be assumed to be fully developed to resist the shear forces.

The overstrength capacity of the shear key should be verified against the sum of the shear capacities of the piles, columns, or shafts connecting to the substructure cap to ensure capacity protection. Therefore:

$$V_{ok} < F_{sk}. \text{ It is suggested } V_{ok} \text{ to be 50\% to 75\% of } F_{sk}$$

Where:

$F_{sk}$  = seismic acceleration in the transverse direction, multiplied by the sum of the dead load reactions at the bearing line under consideration ( $k$ ) for SDC B and C per SGS 5.2.4.1, or

$F_{sk}$  = combined plastic shear capacity of the piles for shear keys intended to fuse for SDC D per SGS 5.2.4.2. Note shear keys in SDC B and C may be designed following requirements for SDC D.

Example details of a shear key at an abutment are given in Figure 8.3-1. The minimum width of 8 inches is based upon concrete placement requirements. A second requirement that the width of the shear key be greater than the height of the bearing is to ensure that interface shear behavior is assumed, and the shear key is not designed for flexure. The 2 foot height of the shear key is based upon a minimum distance assumed to allow for reinforcement development. The shear key longitudinal length is that of the support length of the substructure element upon which it is placed. At stub abutments, the shear key may be tied into both the pile cap and backwall for additional support. The actual concrete width of the shear key, and the amount of reinforcement engaged, are structure-specific, and are subject to design. The additional  $h/1(E)$  bars in the cap beam shall have the same size and spacing as the  $v(E)$  bars in the shear key.

For structures in all SDC's, shear keys may be used even when not required, to reduce substructure widths. This is desirable if the required support lengths in the transverse direction

exceed 48 inches, or result in substructure units that cannot fit within allowable limits. Examples of this include structures with abutments on MSE walls and/or in urban areas that may have very little right-of-way.

DRAFT

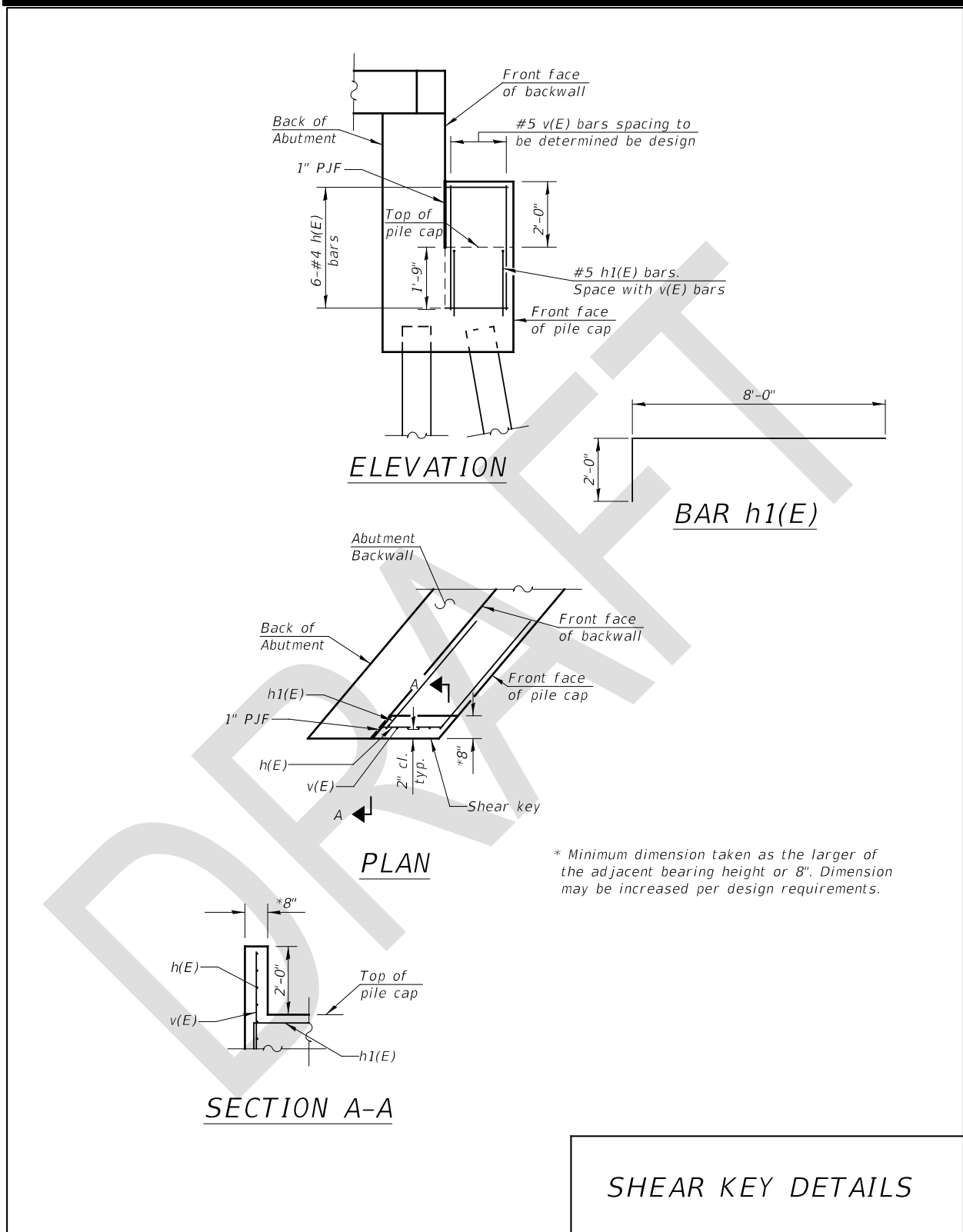

Figure 8.3-1

**8.4 Steel Cross-Frames and Diaphragms**

For the purposes of seismic load path transfer, steel cross-frames and diaphragms are defined to be steel superstructure members that increase superstructure stiffness in the transverse direction. Increased transverse superstructure stiffness is required for a superstructure to remain essentially elastic in that direction and employ a Type 1 seismic design strategy as per Article 3.3 of the SGS.

For structures in SDC A and B, the concrete deck alone is to ensure essentially elastic behavior. The seismic cross-frame loads are not high enough to induce inelastic behavior. For structures in SDC C and D, enhanced steel cross-frame and diaphragm details at supports are required. This is also consistent with Article 6.16 of the AASHTO LRFD Bridge Design Specifications.

For structures in SDC C and D, cross-frames with enhanced stiffness have been developed using the provisions of Article 6.16 in the AASHTO LRFD Bridge Design Specifications and Section 7 of the SGS. These cross-frame details shall be used at supports on steel girder bridges requiring cross-frames in SDC C and D, when a cross-frame design is not already required due to a higher analysis (e.g. curved or highly-skewed structures). The design criteria for this standard cross-frame design is:

- Maximum Substructure Tributary Length = 240 ft.
- Beams are not curved, supports are not skewed greater than 60 degrees
- Maximum Beam Spacing = 8 ft.
- Maximum Applied Seismic Acceleration = 0.79g

When the maximum substructure tributary length exceeds 240 ft., beams are curved, or supports are skewed greater than 60 degrees, a higher level of analysis is required as per AASHTO Code Article 3.6.1.2. This will require non-standard cross-frames to be developed, and the cross-frames used in this Article may not be sufficient.

A beam spacing of 8 ft. was used in conjunction with a maximum substructure tributary length of 240 ft. in the development of these cross-frames. This was considered to be a reasonable upper limit for beam spacing for spans of this length.

The maximum applied seismic acceleration is the actual acceleration used in the design of the bridge. It is not the maximum acceleration given on the seismic design hazard, which often



exceeds the actual design accelerations used. The maximum applied acceleration of 0.79g was determined by first determining the preferred maximum member and detail sizes, then backcalculating the maximum seismic force that could be applied to these preferred details with the maximum span length and beam spacing previously determined.

The standard cross-frames were designed such that all three of these maxima could be applied simultaneously without exceeding the allowable capacities of the cross-frame members. These maxima envelope the vast majority of steel structures in Illinois. Should one of these maxima be exceeded, but the other two not exceeded, the cross-frame designs are likely still robust. The Bureau of Bridges may be contacted if this is the case. If additional analysis is performed, and the cross-frame details prescribed in Figure 8.4-1 of this document are found to be insufficient, concrete drop diaphragms may be used, or alternate steel diaphragms such as bent plates or plate girder sections may be used. These diaphragm types are typically only required in SDC D, and only at pier locations. Details about concrete drop diaphragms are found in Article 8.5.

Expected strengths of  $1.1F_y$  and  $1.3f'_c$  were used in the development of these cross-frames. An allowable overstrength of 1.2 was permitted to account for minimal inelastic behavior, therein allowing a cross-frame that is “essentially elastic.”

End diaphragms at stub abutments, shear studs at 12 in. centers shall be applied to the tops of the top chord.

Diaphragms and cross-frames at substructure units in SDC C and D shall be placed parallel to the support line (e.g. along the CL pier).

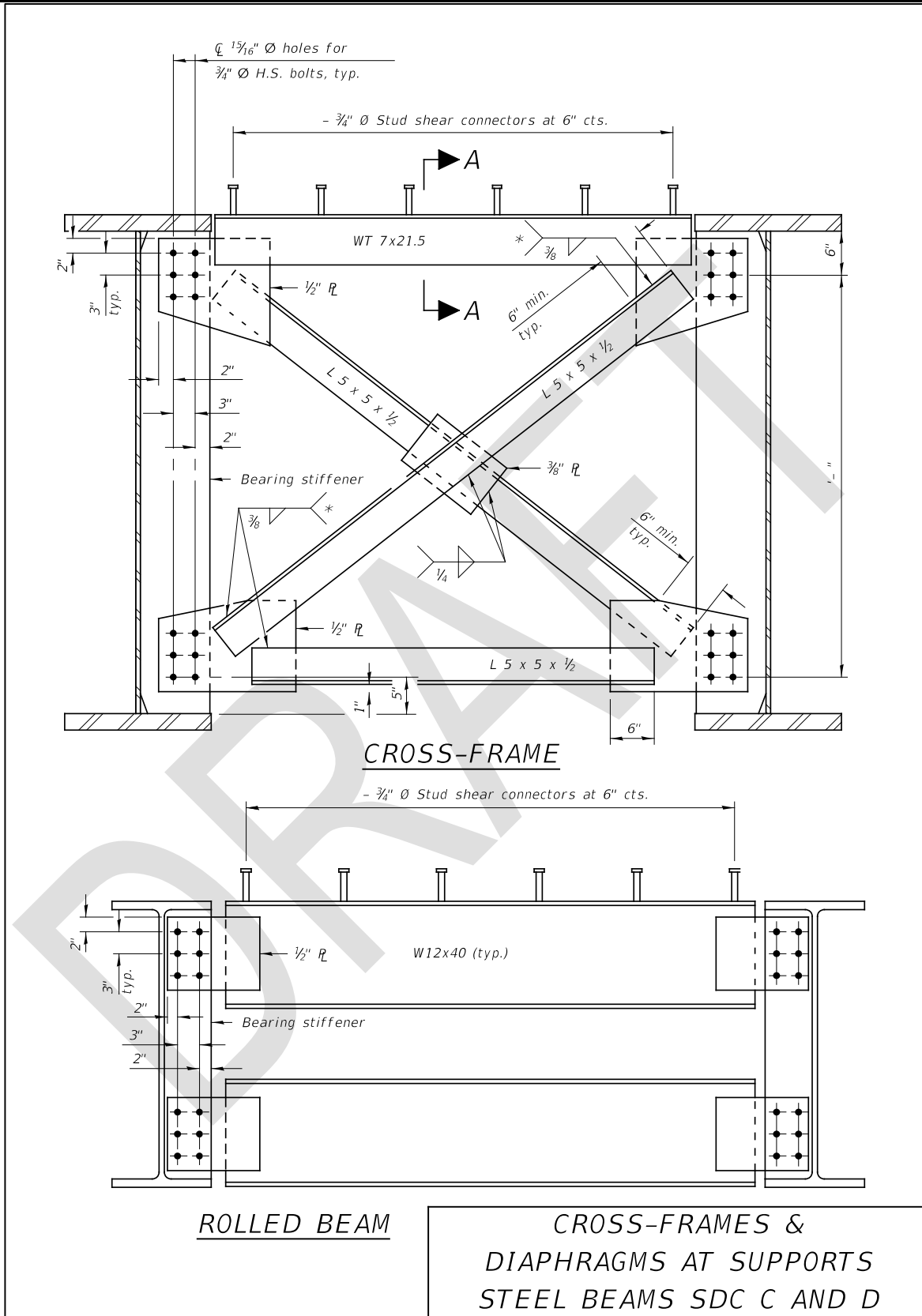

Figure 8.4-1

## **8.5 Concrete Drop Diaphragms at Piers**

Concrete drop diaphragms at piers are concrete members that extend from the top of the pier cap to the bottom of the deck. For superstructures with continuous PPC beams, these are known as continuity diaphragms, and are required. For steel superstructures, concrete drop diaphragms are not required for any reason not related to seismic load propagation.

### **8.5.1 Concrete Drop Diaphragms for PPC Superstructures**

Regardless of SDC, bridges with PPC I-, Bulb-T, and IL-beams require continuity diaphragms at piers for strength and service load cases. These continuity diaphragms also are functional to meet load path requirements for seismic loading. Figure 3.4.10-4 of the Bridge Manual shows a fixed connection for PPC I-beams to piers. The amount of dowel rods determined by the formula in this figure are sufficient for seismic design.

A pinned connection between the drop diaphragm and pier cap may be desired for longitudinal stiffness or proportioning requirements. Use of a pinned or fixed connection can change the substructure stiffness proportioning substantially. Therefore, both options are made available to designers. Figure 8.5-1 of this document shows details for a pinned connection for PPC I-, Bulb-T, or IL-beams at piers. This detail utilizes thicker PJF and sleeved vertical bars, allowing for easier rotation of the beams. This detail is intended to be used in conjunction with Figure 3.4.10-4 of the Bridge Manual. The number of required dowel rods shall be according to Article 8.1.5 of this document.

### **8.5.2 Concrete Drop Diaphragms for Steel Superstructures**

When the parameters in Article 8.4 of this document are exceeded, and calculations show that the details in that article are insufficient, bridges with steel superstructures will require concrete drop diaphragms at piers. The concrete in this detail is not designed. Rather, it is an attempt to encase a steel detail known to be insufficient. These details are also required at abutments for single-span structures with span exceeding 240 ft. Single-span structures of this length are very rare.

Details for concrete drop diaphragms at piers and abutments are available upon request.

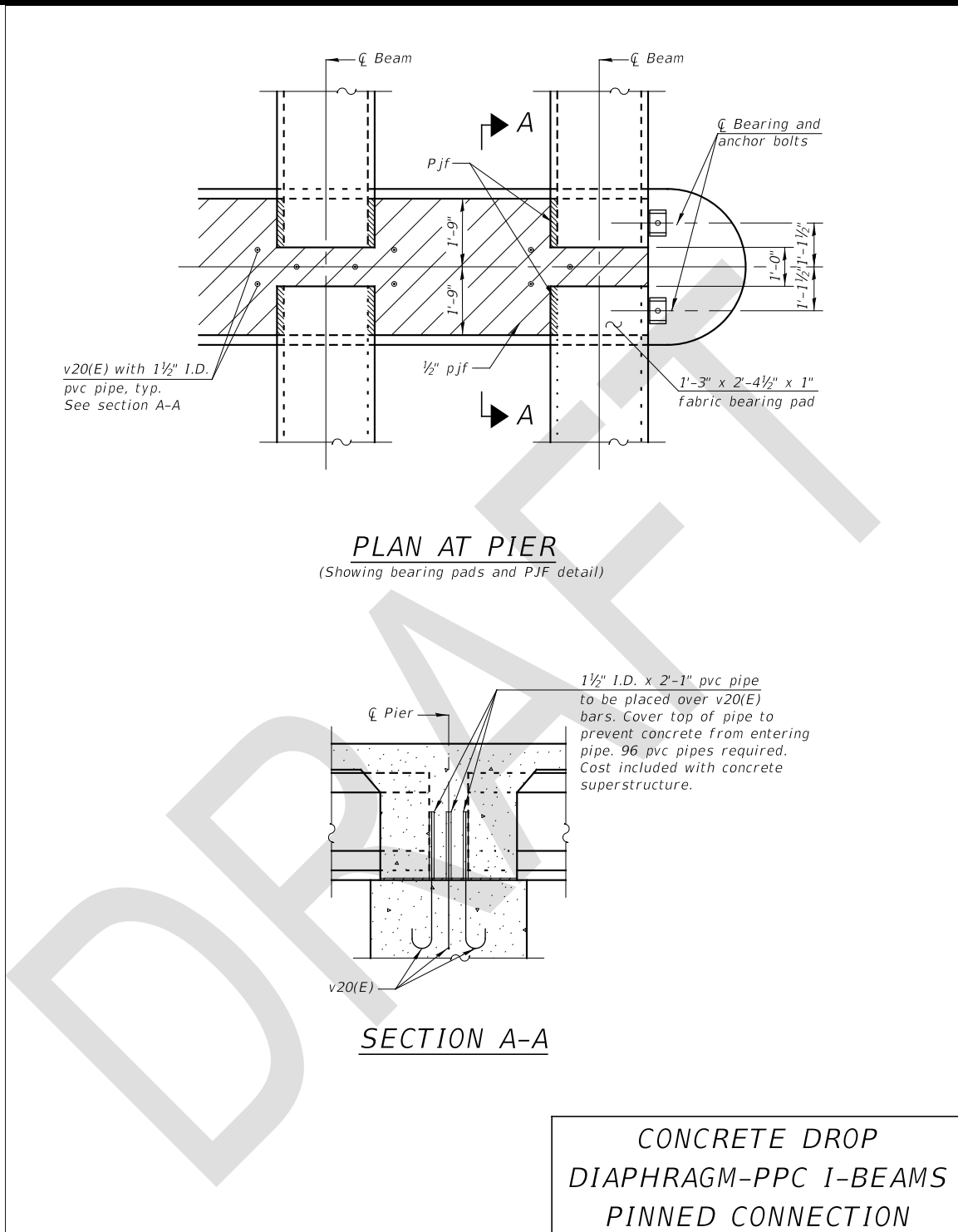

Figure 8.5.2-1

**8.6 Column-to-Cap-Beam and Column-to-Crash-Wall Connections**

Cap beams are defined as concrete beams, upon which beams are seated, and below which are supported by concrete columns or steel piles. They are commonly referred to as pile caps or pier caps elsewhere in the Bridge Manual. The term “cap beam” is used in this document to align the terminology with that in the SGS.

In the SGS, cap beams are considered “integral,” if the columns are directly connected to the superstructure. “Drop” caps are a common term for cap beams where the substructure cap beam and the superstructure beams are disconnected by bearings. IDOT details almost entirely utilize “drop” cap beams.

The SGS uses two terms for column-to-cap-beam connections. “T-joints” refer to joints where the longitudinal cap beam reinforcement may be fully developed on either side of the column. “Knee joints” refer to joints where the longitudinal cap beam reinforcement cannot be fully developed on either side of the column. Knee joints are known to be problematic in that the seismic load path becomes directional and the load path is less predictable. Therefore, T-joints shall be used whenever possible. This may require cap beams to be extended further from the exterior columns to ensure adequate development of the longitudinal cap beam reinforcement.

Crash walls are defined as concrete walls at grade crossings, which support columns supporting cap beams, at midheight of piers on multi-column piers. The intent of crash walls is to provide resistance for vehicular collision loads. However, their location at fixed connections in the transverse direction for concrete columns requires the upper portion of them to be detailed for plastic hinging requirements.

Column-to-crash-wall connections may be considered to be fixed if the Type 2 wall details are used. These details require separate reinforcement cages for the column and crash wall, and the crash wall is required to be at least 18 inches wider than the column diameter. See Article 8.11.2 for more information.

Guidance on detailing of cap beams and crash walls is given in Articles 8.13.2, 8.13.3, 8.13.4, and 8.13.5 of the SGS and described below and in Figure 8.6-1. These requirements are applicable for SDCs C and D. There are no additional requirements for SDCs A and B.

Cap beams and crash walls contain a column connection area, where the column is assumed to create a monolithic connection to the adjacent cap beam or crash wall. Articles 8.13.4 and 8.13.5 of SGS refers to this region as either an “integral joint” or a “non-integral joint,” depending upon whether or not the superstructure is integral with the cap beam. Note that Article 8.12 requires that both the non-integral and integral joint requirements be met for non-integral joints.

To determine whether Articles 8.13.4 and 8.13.5 are applicable, principal concrete stresses and joint proportioning are first checked (8.13.2, 8.13.3 SGS). If the principal stress requirements of Article 8.13.3 are met, then no additional details are required. If the principal stress requirements of 8.13.3 are not met, then the following requirements also apply:

- Transverse reinforcement ratio (Eq. 8.13.3-2, SGS)
- Additional stirrups in column connection (8.13.4.1.2a, 8.13.4.1.2b, 8.13.5.1.2 SGS)
- Additional stirrups in area of cap beam adjacent to column connection (8.13.4.1.2a, 8.13.4.1.2b, 8.13.5.1.1 SGS)
- Horizontal side reinforcement (8.13.4.1.2c)
- Tie bars (J-bars) in column connection (8.13.2.1.2d, 8.13.5.1.4 SGS)
- Additional longitudinal bars in cap beam (8.13.5.1.3 SGS)

For a conventional cap beam design, the minimum depth of a cap beam shall be between  $1.0D_c$  and  $1.25D_c$ , where  $D_c$  is the diameter of the columns tying into the cap beam. This minimum depth does not include any additional steps for beam seats for profile grade. Cap beams with depths exceeding this dimension are allowed, but shall be designed using the strut-and-tie method (8.13.5, SGS).

Connections from columns to crash walls shall be designed using the same additional horizontal reinforcement, shear reinforcement, and tie bars as connections from columns to cap beams. For detailing of tie bars, the depth of connection into the crash wall may be taken as the same depth as used in the cap beam.

Crash wall regions outside of the column connection joint shall be detailed similarly to wall-type piers.

See Figure 8.6-1 for more information.

Note: The additional requirements found in Article 8.13.4 and 8.13.5 of the SGS and detailed below are only applicable if the principal stress limits of Article 8.13.3 of the SGS are not satisfied.

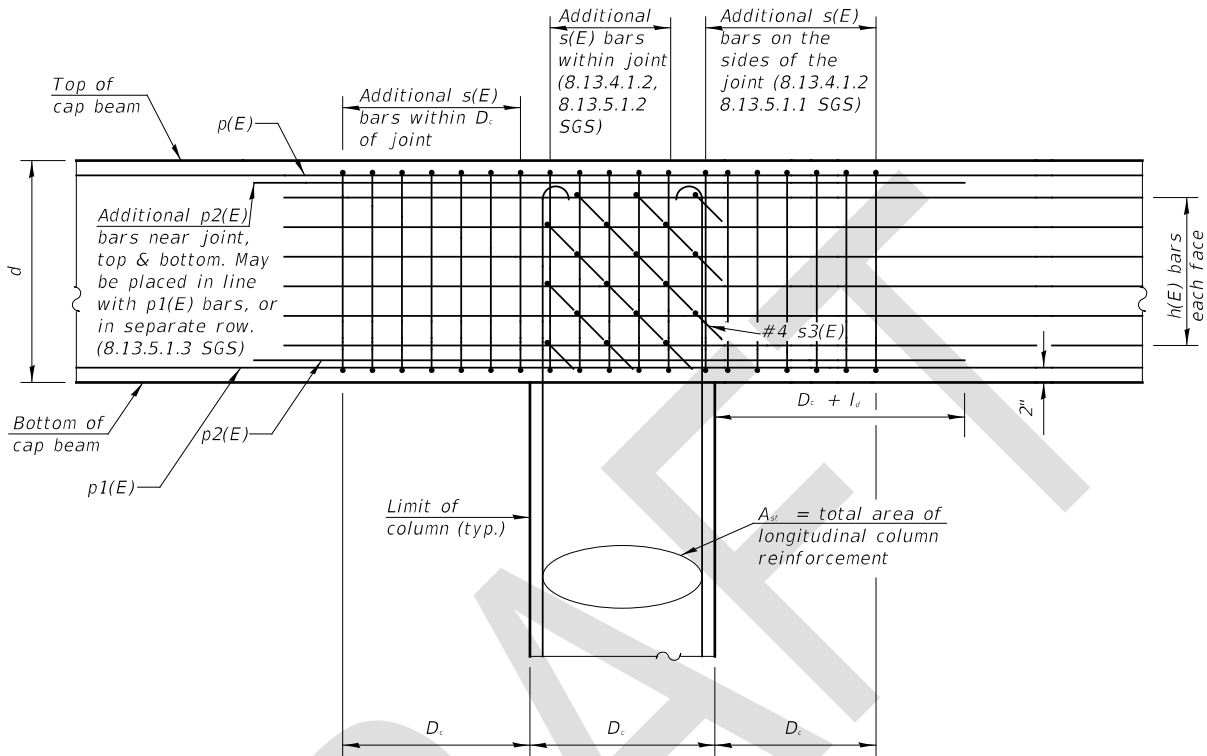

Area of non-integral bent joint cap required Additional Reinforcement:

Longitudinal p2(E) bars:  $A_s \geq 0.245A_v$  (8.13.5.1.3, SGS)

Transverse s(E) bars above and within  $D_c$  of limit of column  $A_s \geq 0.20A_{st}$  (8.13.4.1.2a, SGS)

$D_c < d < 1.25D_c$ , or strut-and-tie model required (8.13.5, SGS)

#4 s3(E) "j-hooks": Hook every other longitudinal h(E) bar and s(E) bar within joint, horizontally and vertically (8.13.5.1.4 SGS)

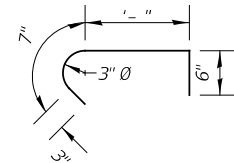

BAR s3 (E)

CAP BEAM  
DIMENSIONS & REINFORCEMENT  
SDC C AND D

Figure 8.6-1

### **8.7 Plastic Hinge Regions**

Plastic hinge regions are defined as areas adjacent to fixed connections in concrete members such as columns or wall-type piers. This region of a structural member undergoes flexural yielding and plastic rotation while retaining flexural strength.

These regions are described in Article 4.11 of the SGS. Because of additional damage that occurs in these regions in a seismic event (loss of concrete cover being the most common), there are additional detailing requirements for plastic hinge regions in SDC B, C, and D. There are no additional plastic hinge region detailing requirements for bridges in SDC A.

Plastic hinge behavior is different in the longitudinal and transverse direction of the bridge. For example, a multi-column pier on a crash wall will have plastic hinge formation in the top and bottom of the columns in the transverse direction. The same pier will likely only have plastic hinge formation in the bottom of the column in the longitudinal direction, and not the top. The directionality of plastic hinge formation does not affect the details used, and the worst case shall be assumed when determining plastic hinge locations.

For bridges with elements in liquefiable soils, details shall be provided for plastic hinge regions in both the non-liquefied configuration and the liquefied configuration (6.8, SGS).

Analytical plastic hinge region lengths for reinforced concrete columns framing into a footing, bent cap, oversized shaft, or encased shaft behaving as a CFST shall be calculated using the formulas in Article 4.11.6, and the requirements of Article 4.11.7 of the SGS. Article 4.11.6 provides an analytical plastic hinge length,  $L_p$ , which is based upon the height of the column from the fixed point to the point of contraflexure, the expected concrete strength, and the longitudinal reinforcement diameter. Article 4.11.7 gives further geometric requirements for the plastic hinge region length. See Figure 8.7-1 for more description.

Analytical plastic hinge region lengths for less common reinforced concrete member types, such as tapered columns, are found in Article 4.11.6 of the SGS and are not repeated here.

Plastic hinge regions shall be shown on the bridge plans, with a note alerting the contractor that lap splicing of longitudinal reinforcement is not allowed in this region.



Use of lap splices in column plastic hinge regions is not allowed. Use of mechanical splices in column plastic hinge regions is only allowed when necessary. See Article 8.8 for more information on reinforcement splicing requirements.

See Figure 8.7-1 for common locations of column plastic hinge regions and required notes about splicing of reinforcement. Hooked bar details for spirals and ties, required for development into the core of the column, are given in Article 8.8.

DRAFT

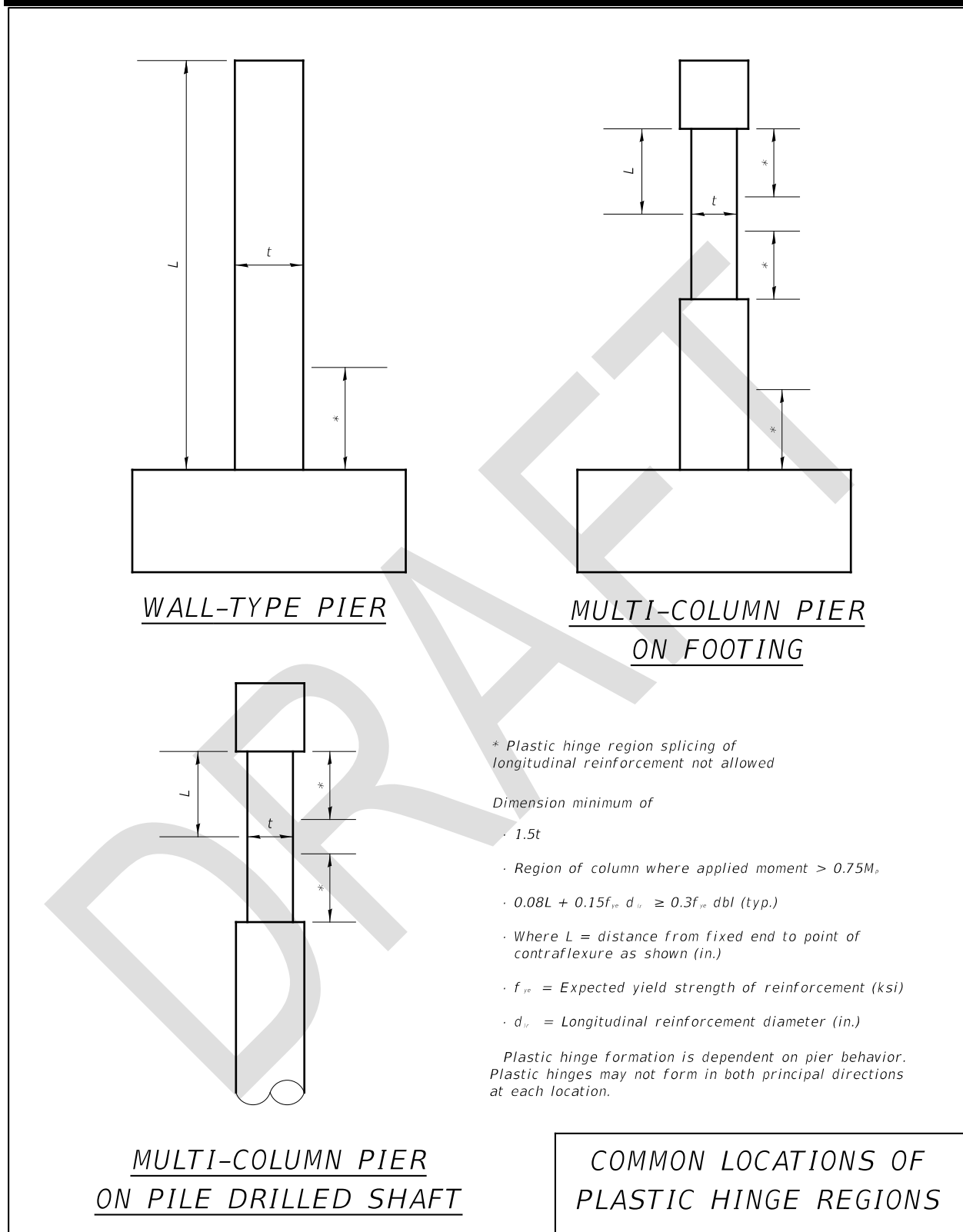

Figure 8.7-1

**8.8 Splices and Development of Reinforcing Steel**

Reinforcing steel splices and development shall meet the requirements of Table 8.8-1 of this document. This table provides requirements based on member type, location, and capacity protection. Definitions of allowable splice types are given below.

**Not Allowed:** No splicing of reinforcement is allowed. This occurs in three locations- plastic hinging regions, the top 20 ft. of Type 2 Shafts and the top 20 ft. of Type 2 walls. These regions shall be clearly identified as “No-Splice Zones” on the plan details. There may be cases where reinforcement splices are required in a plastic hinge region, due to the geometry or length of the region. If this is the case, a mechanical splice shall be used. However, designers should not use mechanical splices in these regions unless there is no other option.

**Mechanical:** Reinforcement may be spliced using mechanical bar splicer assemblies. A schematic of these assemblies shall be shown on the plans when this requirement option is chosen by the designer. Mechanical splicing of spiral or hoop reinforcement may be difficult due to the curvature of the reinforcement. For this reason, seismic hoop and spiral terminations are given below. Mechanical splices shall be staggered between alternating bars as far as feasible, but a minimum distance of 24 in. (5.10.8.4.3b, LRFD). This will avoid congestion of mechanical splices and prevent any abrupt change in column stiffness that may occur due to that congestion.

**Lap:** Reinforcement may be lap spliced. This is not a preferred option in any location, but is allowed in some locations. Mechanical splices may always be substituted for lap splices at the option of the designer.

**Seismic Hook:** This consists of a 135 degree reinforcement hook, with an extension into the core with a length of six times the bar diameter. See Figure 8.8-1. Note that, for stirrups in cap beams, standard reinforcement termination details at a reinforcement corner will meet this requirement.

**Seismic Hoop:** This consists of a hoop detail with both ends of the hoop terminating in a Class A bar lap with seismic hooks, a shop-welded butt weld, or a mechanical splice.

**Spiral Termination:** This consists of 1.5 turns of a spiral, ending with a seismic hook. When used as a splice detail, both portions of the spiral shall use this detail.

Member	Reinforcement	Location	Allowable Splice Type
Columns	Longitudinal	Inside Plastic Hinge Region	Not Allowed
		Outside Plastic Hinge Region	Mechanical
	Transverse	Inside Plastic Hinge Region	Mechanical, Spiral Termination, Seismic Hoop
		Outside Plastic Hinge Region	Same as inside PHR
Walls	Vertical	Inside Plastic Hinge Region	Not Allowed
		Outside Plastic Hinge Region	Mechanical
	Horizontal (Stirrups)	Inside Plastic Hinge Region	Seismic Hook at Reinforcement Intersection
		Outside Plastic Hinge Region	Mechanical, Lap
Type 2 Shaft	Longitudinal	Top 20 ft.	Not allowed
		Elsewhere	Mechanical
	Transverse	Top 20 ft.	Mechanical or Butt Welded
		Elsewhere	Spiral Termination, Seismic Hoop, Mechanical or Butt Welded
Type 2 Wall	Vertical	Top 20 ft.	Not Allowed
		Elsewhere	Mechanical
	Horizontal	Top 20 ft.	Seismic Hook
		Elsewhere	Mechanical, Lap
Cap Beams, Footings	Longitudinal	All	Mechanical
		Transverse	Seismic Hook on Stirrup Corner

*Table 8.8-1*

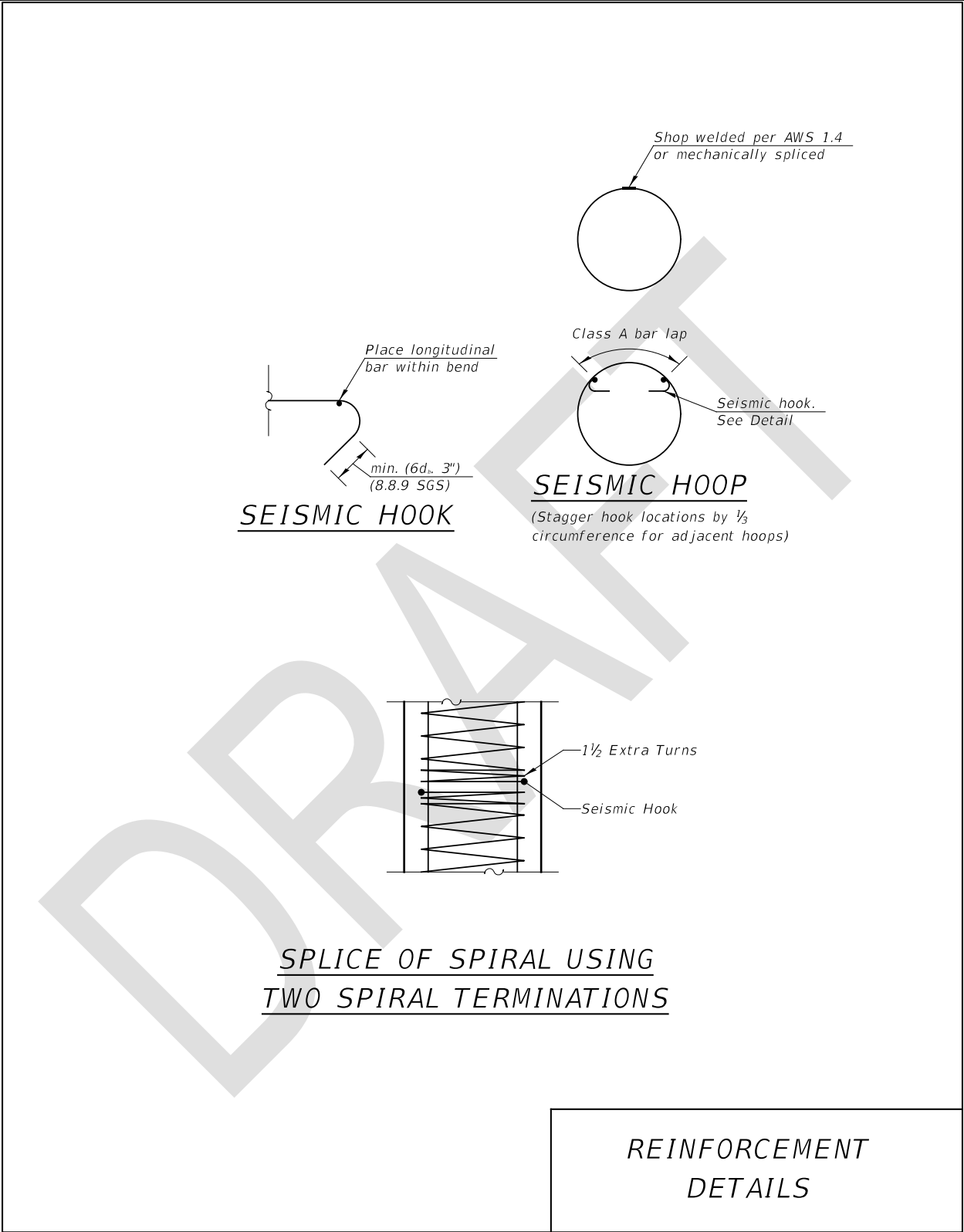

Figure 8.8-1

**8.9 Concrete Columns**

As per SGS Article 8.1 of the Guide Specifications, a concrete substructure supporting member is considered to be a column if the height-to-diameter ratio is not less than 2.5. Concrete members with aspect ratios less than this ratio are considered to be wall-type piers, with details as shown in SGS Article 8.6.

Bridges with one second spectral accelerations ( $S_{D1}$ ) less than 0.10g (i.e. “low” SDC A) do not require additional seismic detailing for concrete columns as per Article 8.2 of the SGS.

Bridges with one second spectral accelerations ( $S_{D1}$ ) greater than 0.10g but less than 0.15g (i.e. “high” SDC A) have the following seismic detailing requirements for columns:

- Transverse reinforcement ratio shall be a minimum of 0.002 (8.6.5 SGS)
- When splicing of transverse reinforcement is required, the splices shall terminate in seismic hook. This consists of a 135 degree bar bend and development into the core of the column
- Transverse reinforcement shall be a minimum of #4 reinforcement for longitudinal reinforcement of sizes #9 and smaller. Transverse reinforcement shall be a minimum of #5 reinforcement for longitudinal reinforcement of sizes #10 and larger (8.8.9 SGS)

Bridges in SDC B, SDC C, and SDC D require additional seismic detailing as described below.

Details for connections of columns to shafts are found in Article 8.10 of this document. Details for connections of columns to cap beams and crash walls are found in Article 8.6.

**8.9.1 Round Concrete Columns in SDC B, C, and D**

Round concrete columns for bridges in SDC B, C, and D have the following seismic detailing requirements. Some requirements are not applicable to all three of these zones, and are annotated accordingly.

Column dimensions:

- The column shall have a maximum height-to-diameter ratio of 6, where the height is taken as the clear dimension between connecting concrete elements (SDC C and D only).
- The column shall satisfy the maximum axial load requirements of (8.7.2 SGS) (SDC C and D only).

Longitudinal reinforcement requirements shall be according to Table 8.9.1-1:

Requirement	SDC B	SDC C	SDC D	Reference
Minimum Ratio	0.007	0.01	0.01	8.8.2, SGS
Maximum Ratio	0.04	0.04	0.04	8.8.1, SGS
Extensions into Cap Beams and Footings	5.10.8.2.4, LRFD*	8.8.4, SGS*	8.8.4, SGS*	
Bundled Reinforcement Extensions	-	8.8.5, SGS	8.8.5, SGS	
Maximum Bar Size	-	8.8.6, SGS	8.8.6, SGS	
Maximum Spacing	8 in.	8 in.	8 in.	C8.6.3, SGS
Splicing	See Article 8.8 of this document			

*Table 8.9.1-1*

\*Longitudinal reinforcement extensions may terminate with standard hook details, headed reinforcement, or a combination of the two. Hooked reinforcement is preferred, but hooks can become congested when the number of longitudinal bars becomes large. When orienting hooked reinforcement, care should be taken to orient hooks both in the direction inside the core and the direction outside the core. This will reduce reinforcement congestion and also add ductility to the connection.

For SDC C and D, longitudinal column reinforcement shall extend into connecting members such as cap beams and footings as close as possible to the opposing face of the member, and shall not be less than the prescriptive length given in Article 8.8.4 of the Guide Specifications.

Transverse reinforcement requirements shall be according to Table 8.9.1-2:

Requirement	SDC B	SDC C	SDC D	Reference
Type	Spiral or Hoop	Hoop	Hoop	
Minimum Ratio	0.003	0.005	0.005	8.6.5, SGS
Maximum Ratio	None	None	None	
Extensions into Cap Beams and Footings	*	*	*	
Minimum Bar Size	8.8.9, SGS	8.8.9, SGS	8.8.9, SGS	
Maximum Bar Size	#6**	#6**	#6**	
Maximum Pitch	***	***	***	
Splicing	See Article 8.8 of this document			

*Table 8.9.1-2*

\*Transverse reinforcement shall extend into adjacent members as far as possible while still accommodating the hook or head placement of the longitudinal reinforcement. This distance shall be at least the maximum of either 0.5 times the column diameter, or 15 in.

\*\*Transverse reinforcement of sizes greater than #6 should be avoided when possible. This is not a seismic concern, but rather is due to fabrication concerns for creating spirals and hoops with larger-diameter reinforcement. For large-diameter columns (e.g. diameters exceeding 60 in.), transverse reinforcement areas greater than #6 may be required to meet volumetric and/or ductility requirements. In these cases, the engineer may consider the use of bundled hoops.

\*\*\*Inside the plastic moment hinge region, the pitch of transverse reinforcement shall be based upon the minimum of the following:

- Reinforcement required for applied shear (8.6.3, 8.6.4 SGS)
- Minimum volumetric ratio (5.6.4.6 LRFD)
- Minimum confinement ratio (5.11.4.1.4 LRFD)
- Maximum and minimum pitch (8.8.9 SGS)

Outside the plastic moment hinge region, the pitch of the transverse reinforcement is required to meet the same requirements as those within the plastic moment hinge region,



with the exception that the minimum confinement ratio is not required (SDC B, C, and D) and the minimum volumetric ratio shall not be less than 50% of the volumetric ratio within the plastic moment hinge region (SDC C and D only).

See Figure 8.9.1-1 for details.

DRAFT

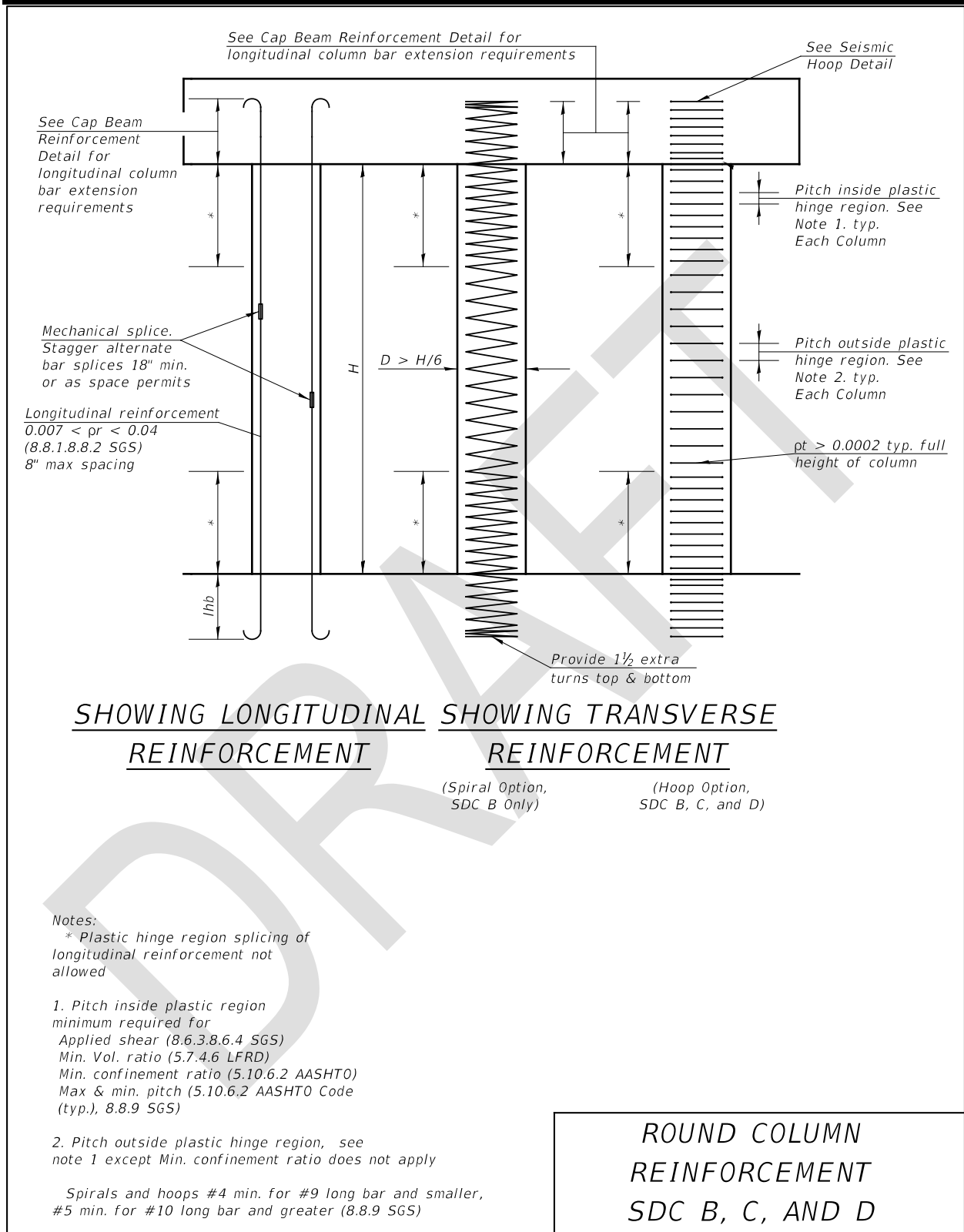

Figure 8.9.1-1

*8.9.2 Rectangular Concrete Columns*

Because use of seismic details for trapezoidal columns results in difficult detailing and placement of reinforcement, the use of round columns instead of trapezoidal columns in regions of Illinois where seismic detailing is required is strongly encouraged. Regardless, the detailing of ties in rectangular columns is illustrated in 8.9.2-1.



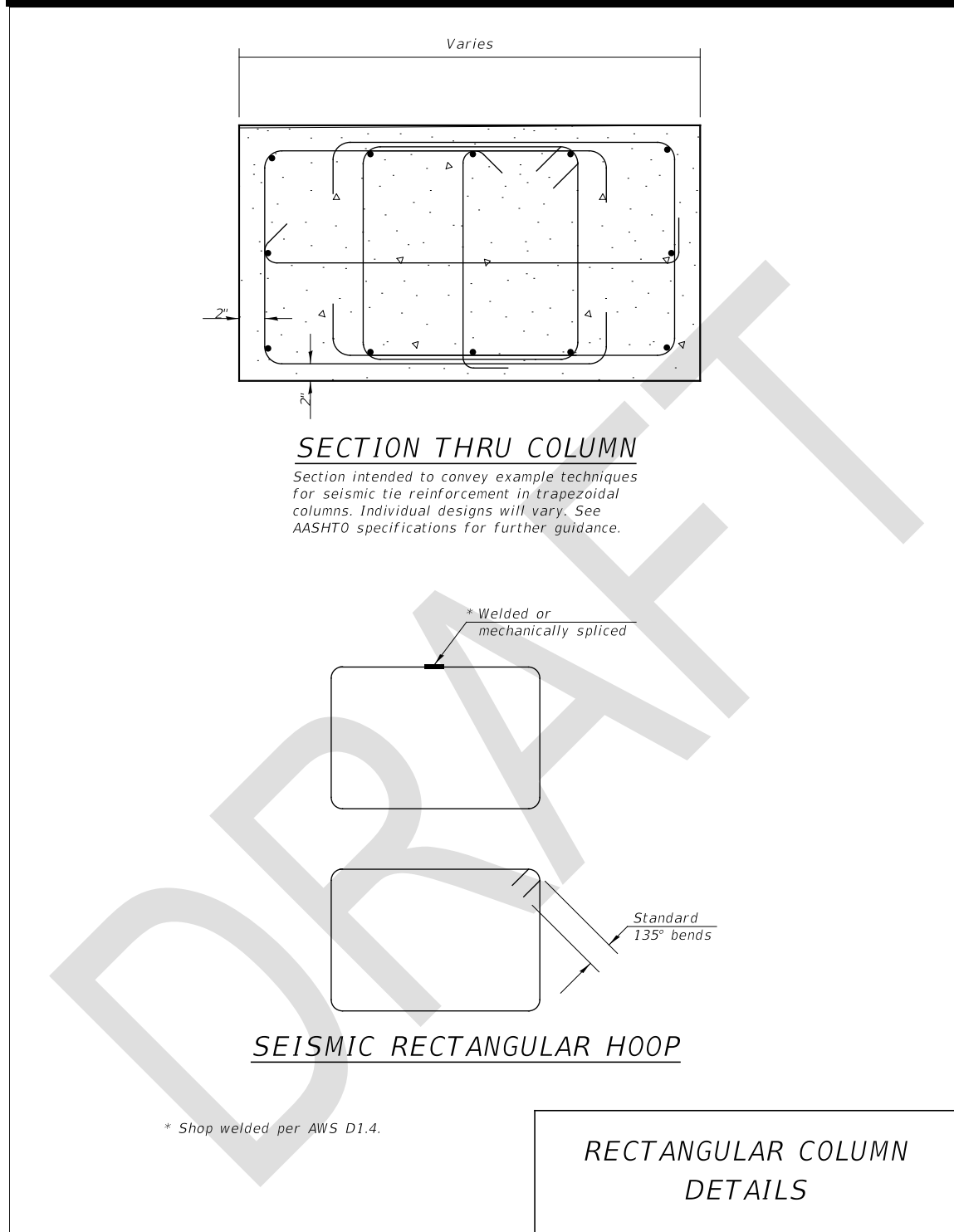

Figure 8.9.2-1

**8.10 Concrete Shafts**

Concrete shafts are defined as round concrete members extending into soil that act as foundation members for the substructure unit. They are typically connected to substructure units via a shaft-supported footing, as described in Article 8.12 of this document. They also may tie directly into concrete columns using a Type 2 Shaft connection, as described below.

Bridges with one second spectral accelerations ( $S_{D1}$ ) less than 0.10g (i.e. “low” SDC A) do not require additional seismic detailing for concrete shafts as per Article 8.2 of the SGS.

Bridges with one second spectral accelerations ( $S_{D1}$ ) greater than 0.10g but less than 0.15g (i.e. “high” SDC A) only have the following seismic detailing requirements for shafts:

- Transverse reinforcement ratio shall be a minimum of 0.002 (Article 8.6.5 SGS)
- When splicing of transverse reinforcement is required, the splices shall terminate in seismic hook. This consists of a 135 degree bar bend and development into the core of the column
- Transverse reinforcement shall be a minimum of #4 reinforcement for longitudinal reinforcement of sizes #9 and smaller. Transverse reinforcement shall be a minimum of #5 reinforcement for longitudinal reinforcement of sizes #10 and larger (SGS 8.8.9)

Bridges in SDC B, SDC C, and SDC D require additional seismic details. Shaft longitudinal and transverse reinforcement shall meet the requirements for concrete columns found in Article 8.9 for their respective seismic zone.

To keep hinges above ground and inspectable, bridges with columns tying directly into concrete shafts require the connecting shaft to be oversized, with separate reinforcement cages for the concrete column and the concrete shaft. This provides a plastic hinge region for the columns that is either above or just below the ground surface, allowing for more predictable behavior in a seismic event with damage occurring in inspectable areas. This member type, with larger shafts and separate reinforcement cages, is known as a “Type 2 Column.”

For a column and shaft to be considered a Type 2 column, the following requirements shall be met:

- The column and shaft shall have independent reinforcement cages, with the column reinforcement cage sufficiently smaller than the shaft reinforcement cage. A minimum of 3 in. clear between the outside of the column transverse reinforcement and the inside of the longitudinal shaft reinforcement is required.
- The shaft placement tolerances of 3 in. and cage placement tolerances of 1.5 in., found in Article 516.13 of the Standard Specifications for Road and Bridge Construction, shall be accounted for when determining the column dimensions, shaft dimensions, and reinforcement clearances.
- The shaft is designed to be capacity-protected against the column

The combination of these three items, in conjunction with the fact that concrete shafts are sized in six inch increments, typically will require an oversized shaft to be 18 in. larger than the attached column.

Type 2 column connections have the following detailing requirements:

- The column reinforcement shall be terminated in the shaft at two locations, with 50% of the reinforcement terminating a distance of one column diameter plus one development length from the column/shaft interface, and the other 50% terminating at a distance one development length beyond the first distance. The development length may be calculated assuming expected concrete and reinforcement material properties (SGS 8.8.10).
- The transverse reinforcement in the plastic moment region of the column shall extend to the depth of the ultimate cutoff of the column reinforcement termination in the shaft
- The transverse reinforcement extension from the column into the shaft shall have a ratio at least 50% of that in the plastic moment region of the column (SGS 8.8.11). The transverse reinforcement extension shall extend over the entire embedded length of the column cage.
- The volumetric ratio of the transverse shaft reinforcement shall be at least 50 percent of the transverse column reinforcement for the depth to the ultimate termination of column reinforcement (SGS 8.8.12).
- The spacing of the transverse shaft reinforcement may be doubled in the region outside of the column longitudinal reinforcement extension, but this spacing shall be verified against the applied loads (SGS 8.8.12).
-

See Figure 8.10-1.

DRAFT

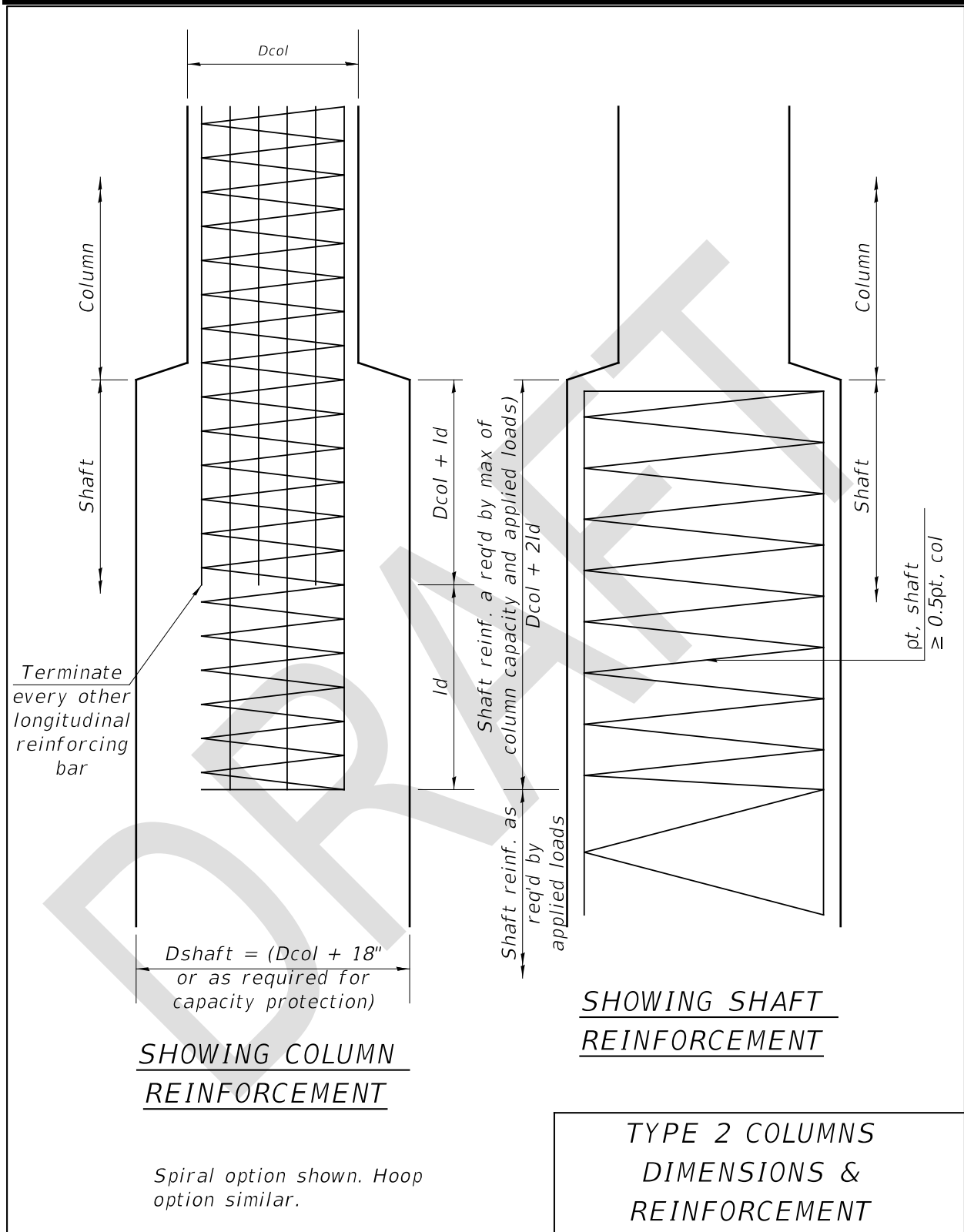

Figure 8.10-1



**8.11 Wall-Type Piers**

As per Article 8.1 of the Guide Specifications, a concrete substructure supporting member is considered to be wall-type if the height-to-width ratio does not exceed 2.5. Concrete members with aspect ratios not exceeding this ratio are considered to be concrete columns, with details as shown in Article 8.5.

Bridges in SDC A do not require additional seismic details for wall-type piers.

Bridges in SDC B, SDC C, and SDC D require additional seismic details as described below. Some requirements are not applicable to all three of these zones, and are annotated accordingly.

**8.11.1 Wall-Type Piers in SDC B, C, and D**

Horizontal and vertical reinforcement should not be dependent on tie reinforcement requirements i.e. if tie reinforcement requires more horizontal/vertical intersections, the number of horizontal or vertical bars should not be increased to meet this requirement.

Wall-type piers for bridges with  $0.10g < S_{D1} \leq 0.30g$  i.e. high SDC A and SDC B require the following details:

Wall-type pier dimensions:

- The pier shall have a maximum height-to-thickness ratio of 6, where the height is taken as the clear height above the top of the footing to the bottom of the superstructure or bent cap (SDC C and D only).

Vertical wall-type reinforcement shall meet the requirements of Table 8.11.1-1:

Requirement	SDC B	SDC C	SDC D	Reference
Minimum Ratio	0.0025	0.0025	0.005	8.8.2, SGS
Maximum Ratio	0.04	0.04	0.04	8.8.1, SGS
Extensions into Cap Beams and Footings	5.10.8.2.4, LRFD	8.8.4, SGS*	8.8.4, SGS*	
Bundled Reinforcement Extensions	-	8.8.5, SGS	8.8.5, SGS	
Minimum Bar Size	8.8.9, SGS	8.8.9, SGS	8.8.9, SGS	
Maximum Bar Size	8.8.6, SGS	8.8.6, SGS	8.8.6, SGS	
Maximum Spacing Inside Plastic Hinge Region	18 in.	18 in.	18 in.	8.6.10, SGS
Maximum Spacing Outside Plastic Hinge Region	18 in.	18 in.	18 in.	8.6.10, SGS
Splicing	See Article 8.8 of this document			

*Table 8.11.1-1*

\*Longitudinal reinforcement extensions may terminate with standard hook details, headed reinforcement, or a combination of the two. Hooked reinforcement is preferred, but hooks can become congested when the number of longitudinal bars becomes large. When orienting hooked reinforcement, care should be taken to orient hooks both in the direction inside the core and the direction outside the core. This will reduce reinforcement congestion and also add ductility to the connection.

For SDC C and D, longitudinal column reinforcement shall extend into connecting members such as cap beams and footings as close as possible to the opposing face of the member, and shall not be less than the prescriptive length given in Article 8.8.4 of the Guide Specifications.

Horizontal wall-type reinforcement shall be according Table 8.11.1-2:

Requirement	SDC B	SDC C	SDC D	Reference
Minimum Ratio	0.0025	0.0025	0.0025	8.6.10, SGS
Maximum Ratio	0.04	0.04	0.04	8.8.1, SGS
Placement into Cap Beams and Footings	*	*	*	
Minimum Bar Size	8.8.9, SGS	8.8.9, SGS	8.8.9, SGS	
Maximum Bar Size	None	None	None	
Maximum Spacing Inside Plastic Hinge Region	8.8.9, SGS	8.8.9, SGS	8.8.9, SGS	
Maximum Spacing Outside Plastic Hinge Region	18 in.	18 in.	18 in.	8.6.10, SGS
Splicing	See Article 8.8 of this document			

*Table 8.11.1-2*

\*Horizontal reinforcement shall be placed into adjacent members as far as possible while still accommodating the hook or head placement of the longitudinal reinforcement. This distance shall be at least the maximum of either 0.5 times the column diameter, or 15 in.

Tie reinforcement requirements:

- Inside the plastic hinge region, the volumetric ratio of tie reinforcement shall be based upon the maximum of the following:
  - Reinforcement required for applied shear (5.11.4.2 LRFD, 8.6.1, 8.6.2, 8.6.3, 8.6.9 SGS)
  - Minimum confinement ratio (5.11.4.1.4 LRFD)
  - Maximum and minimum pitch (5.10.4.2 LRFD, 8.8.9 SGS)
- Outside the plastic moment hinge region, the volumetric ratio of the tie reinforcement shall not be less than one-half the volumetric ratio of the tie reinforcement inside the plastic moment hinge region (8.8.8, SGS).

- For ease of placement, tie reinforcement shall terminate in a 90 degree hook on one end and a 135 degree hook on the opposite end, and staggered such that alternating layers of ties have opposing hooks. Tie bars should be placed at intersections of horizontal and vertical bars, and oriented at a 45 degree angle such that both the horizontal and vertical bar are tied. See Figure 8.11.1-1 for more information.
- Tie reinforcement shall extend into connecting elements such as cap beams and footings to the distance point of tangency for vertical bar bends, or 3 in. from the inside face of the head for headed vertical bars (8.8.8, SGS).
- The spacing requirements of Article 8.8.7, 8.8.8, and 8.8.9 of the Guide Specifications shall apply.

See Figure 8.11.1-1.

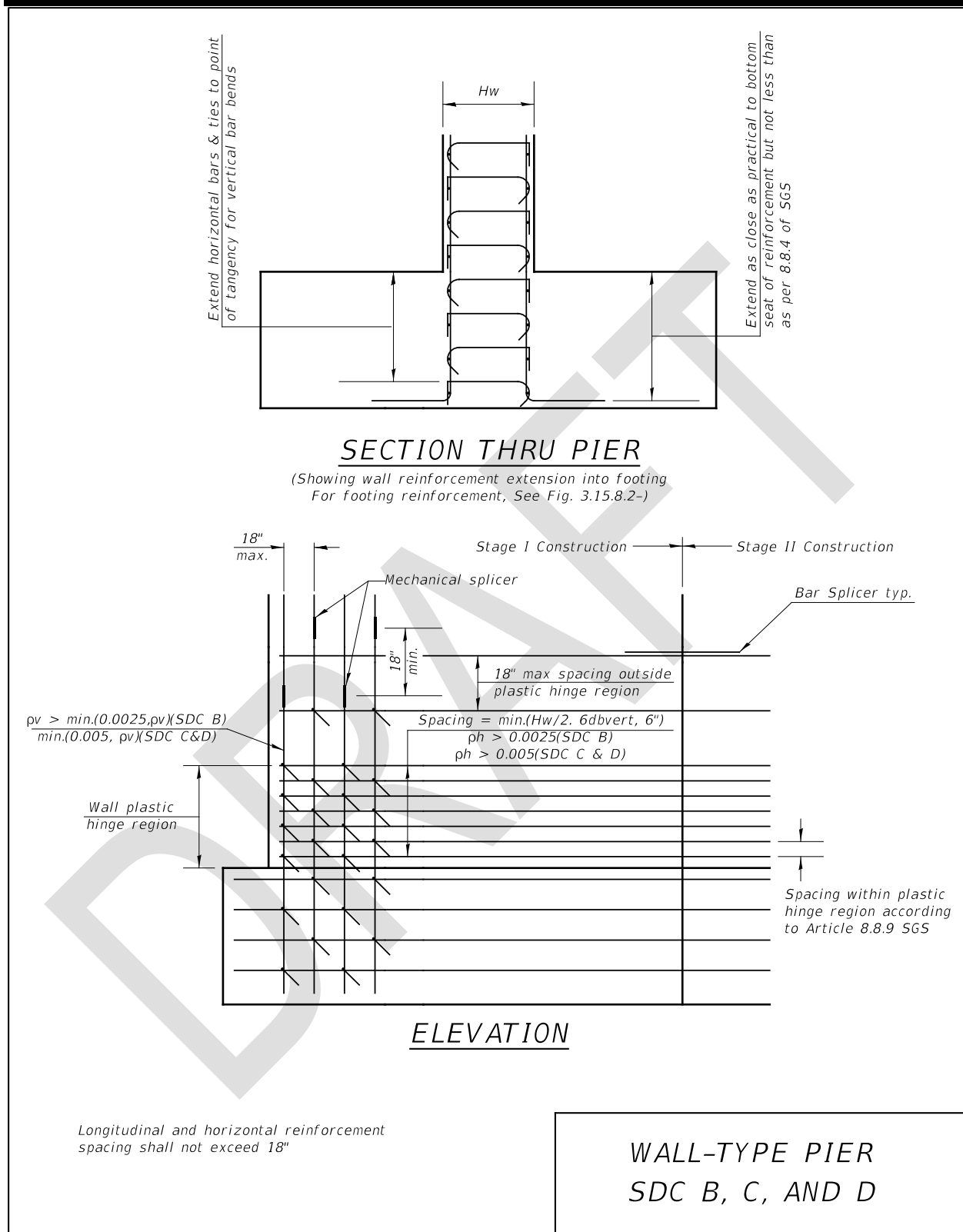

Figure 8.11.1-1

**8.11.2 Type 2 Wall-Type Piers**

There may be cases where wall-type piers are required to have footings deeper than five feet into the ground. For example, a high rock line may require a spread footing, but the rock line may be ten feet underground, requiring a longer wall stem than typically used. To keep hinges above ground and inspectable, bridges with wall-type piers in SDC B, C, and D with top-of-footing elevations more than five feet below the ground surface tying require a thickened lower portion of the wall to promote above-ground hinging. This member type is also known as a “Type 2 Wall.”

For a wall to be considered Type 2, the following requirements shall be met:

- The upper and lower portion of the wall shall have independent reinforcement cages, with the upper reinforcement cage sufficiently smaller than the lower reinforcement cage. A minimum of 3 in. clear between the outside of the upper portion of the wall transverse reinforcement and the inside of the longitudinal reinforcement in the lower portion of the wall is required.
- The lower portion of the wall shall be designed to be capacity-protected against the upper portion of the wall.

Due to the reinforcement geometric requirements, the lower portion of the wall will be at least six inches thicker than the upper portion of the wall. Added thickness to ensure plastic hinging occurs above the lower portion of the wall may be added at the discretion of the designer.

Type 2 wall connections have the following detailing requirements:

- The upper wall reinforcement shall be terminated in the lower portion of the wall at two locations, with 50% of the reinforcement terminating a distance of one upper wall thickness plus one development length from the column/shaft interface, and the other 50% terminating at a distance one development length beyond the first distance, or at the bottom of the footing if the lower part of the wall is not tall enough to accommodate this distance. The development length may be calculated assuming expected concrete and reinforcement material properties (8.8.10, SGS).
- The transverse reinforcement in the plastic hinge region of the upper portion of the wall shall extend to the depth of the upper wall reinforcement termination in the lower portion of the wall.

- The tie reinforcement area in the region of the upper wall reinforcement extension into the lower portion of the wall shall be at least 50 percent of that in the plastic hinge region of the upper portion of the wall (8.8.9, SGS)
- The volumetric ratio of the tie reinforcement in the lower portion of the wall shall be at least 50 percent of the transverse wall reinforcement for the depth to the ultimate termination of upper wall reinforcement (8.8.12, SGS)

See Figure 8.11.2-1.

DRAFT

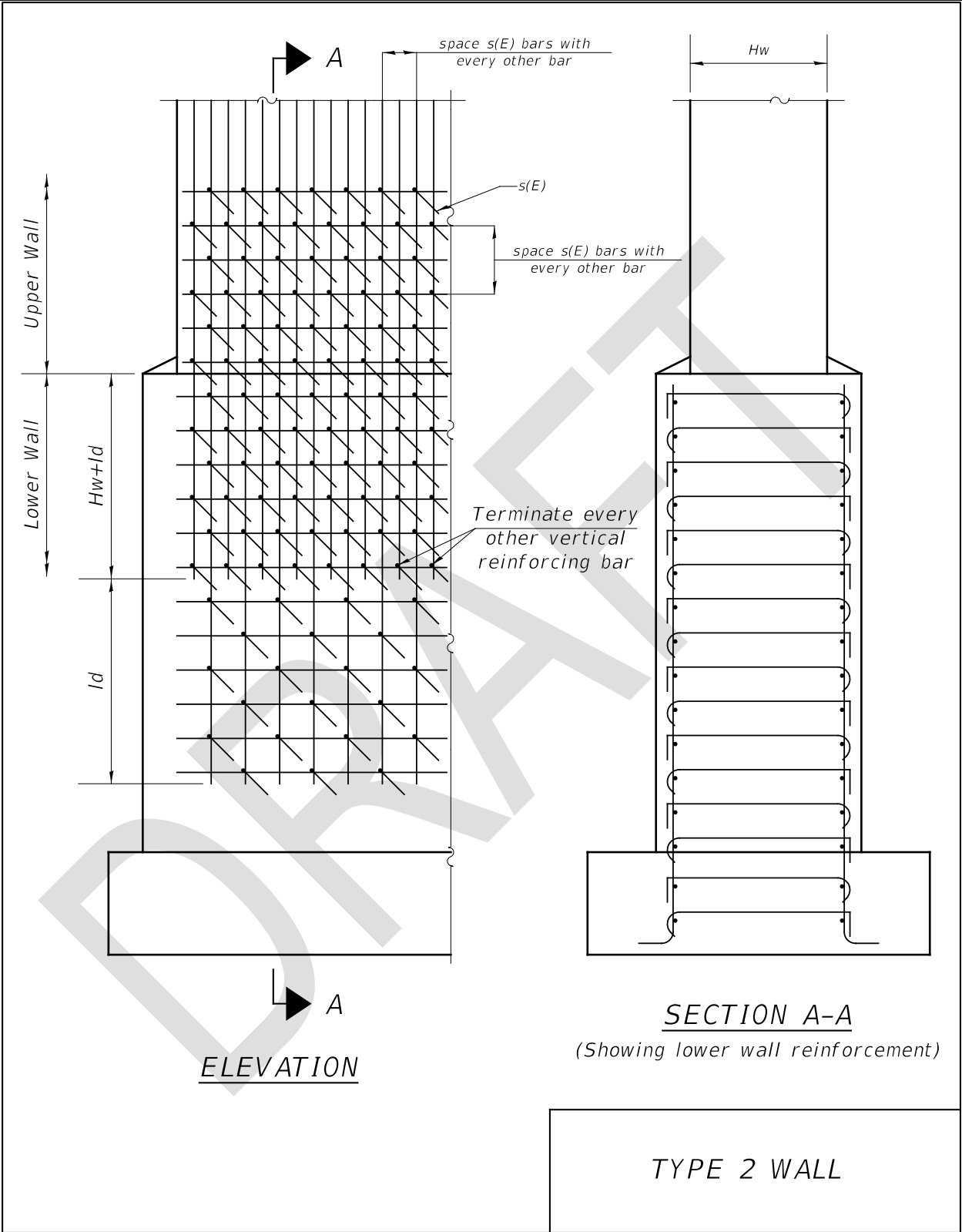

Figure 8.11.2-1



**8.12 Concrete Footings**

Concrete footings are defined as either spread footings, wherein the foundational strength is based on bearing between the footing and soil, or pile-supported footings, wherein the foundational strength is based on piles or shafts extending from the footing into the soil. There are no additional requirements for concrete footings for bridges in SDC A. For bridges in SDC B, C, and D, there are proportioning requirements and detailing requirements as stated below.

Spread footings in SDC B, C, and D shall be proportioned to meet the requirements of Article 6.3.2 of the SGS. Pile-supported footings in SDC B, C, and D assumed to behave as rigid members shall be proportioned to meet the requirements of Article 6.4.2 of the SGS. Spread footings in SDC A may also be proportioned to meet these requirements, but this is not a requirement, and the proportion equation would only be used as an aid to the designer. Use of a rigid footing is a common assumption, and increases the allowable footing area to be used in spread footing calculations and simplifies pile load calculations in pile-supported footing calculations.

The effects of spread footing rocking may be advantageous in stiffness proportioning, and may be considered in design, see also Section 6.4 of this document for more information.

Column and wall connections to footings shall meet the requirements of Article 6.4.7 of the SGS. See Figure 8.12-1. This includes the following requirements:

- Longitudinal column and wall reinforcement shall be extended as close as possible to the bottom mat of footing reinforcement and meet minimum length requirements
- Longitudinal column and wall reinforcement shall terminate in 90 degree hooks
- Transverse column and wall reinforcement shall extend to the point of tangency of the 90 degree hook in the longitudinal column or wall reinforcement
- Stirrups shall connect the top and bottom mat of the footing reinforcement for a distance equal to one footing thickness from the outside of the column or wall. Allowable combinations of 90 degree hooks, 180 degree hooks, and reinforcement heads are found in Fig. 6.4.7-1 of the SGS.
- Longitudinal and transverse footing reinforcement shall terminate with either 90 degree hooks and bar extensions, or headed reinforcement

Footings in SDC C and D shall be proportioned such that the footing joint shear requirements of Article 6.4.5 of the SGS are met.

The tops of concrete shafts connecting into footings shall be detailed using the same details required for column connections to cap beams. The requirements of Article 8.16 of the SGS for concrete piles shall also apply for drilled shafts.

DRAFT

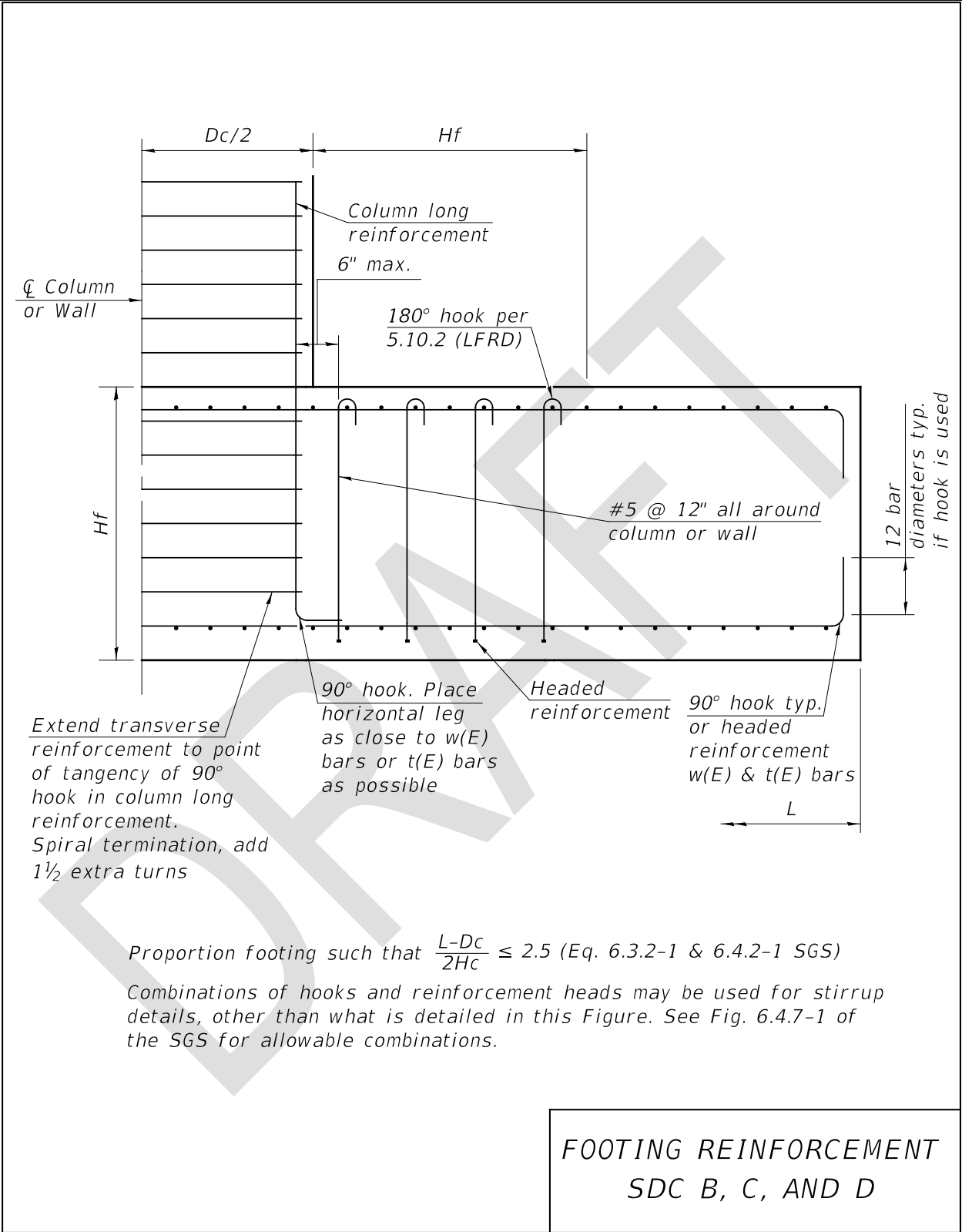

Figure 8.12-1

**8.13 Piles**

Piles are defined as deep foundation members, typically steel members used as supporting members for cap beams or footings. Pile types such as precast concrete or timber are typically not used on the state system, and seismic details for these pile types are not maintained by the Department.

See also other pertinent section of the Design Manual related to design of H-Piles, including 6.4 Foundation Modeling and Fixity and 7.7.4 Steel Members.

Bridges in SDC A do not have any required pile connection details. For bridges in SDC B, C, and D, pile connections shall be detailed as follows.

When detailing pile connections, there are two different aspects to be considered. Pile fixity (i.e. fixed vs. pinned connection), and presence of uplift shall be considered when determining appropriate pile connection details.

Whether piles are considered to be fixed or pinned at the footing interface will result in changes in stiffness to the substructure unit that may help the designer in proportioning substructure units to obtain regularity. Neither a fixed nor a pinned connection is considered to be a preferred detail, rather, the designer may choose the detail allowing for the best stiffness proportioning for the structure.

To assume fixed pile behavior, piles shall be extended a distance equal to or greater than that given in Table 8.13-1 into the concrete element. This table shows the required extension for the pile sizes permitted as per Article 7.7.4 of this document. This extension is required regardless of whether or not there are positive reinforcement connections to the pile.

Pile Size	in.
HP14x117	32
HP14x102	30
HP14x89	28
HP12x84	28
HP12x74	26
HP12x63	24
HP10x57	23
HP10x42	19
HP8x36	18
Metal Shell Piles (all)	24

Table 8.13-1

Pinned behavior may only be assumed if the pile is extended 1 ft. into the concrete element. This allows the pile head to extend roughly 6 in. to 9 in. above the bottom mat of reinforcement, allowing for enough room for positive connections of reinforcement or stud shear connectors to be applied. When pinned behavior is assumed, the positive pile connections shown in Figures 8.13-1, 8.13-2, and 8.13-3 shall be used. This is a requirement for piles with shallow embedments as per Article 10.7.1.2 of the AASHTO LRFD Bridge Design Specifications.

In order to maintain the design procedures used to develop standard integral abutment details, piles at integral abutments shall be fixed. Piles at integral abutments do not require additional stud or reinforcement details. Piles at integral abutments have a 2 ft. embedment requirement, regardless of size.

For individually encased and solid wall encased pile bents, piles should be fixed into the pile cap. The encasements are not considered to be structural concrete. Note that a deeper cap may be needed to fulfill this requirement.

When uplift is anticipated in a seismic event, the piles shall be positively connected to the concrete element via attached reinforcement, regardless of if the pile connections are assumed fixed or pinned. Details of pile connections for H-piles and metal shell piles are given in Figures 8.13-1, 8.13-2, and 8.13-3.

For metal shell piles, the interior reinforcement and reinforcement extensions are intended to provide additional fixity for the piles, and shall not be used to provide additional capacity.

The designer should consider the effects of pile corrosion when applicable.

DRAFT

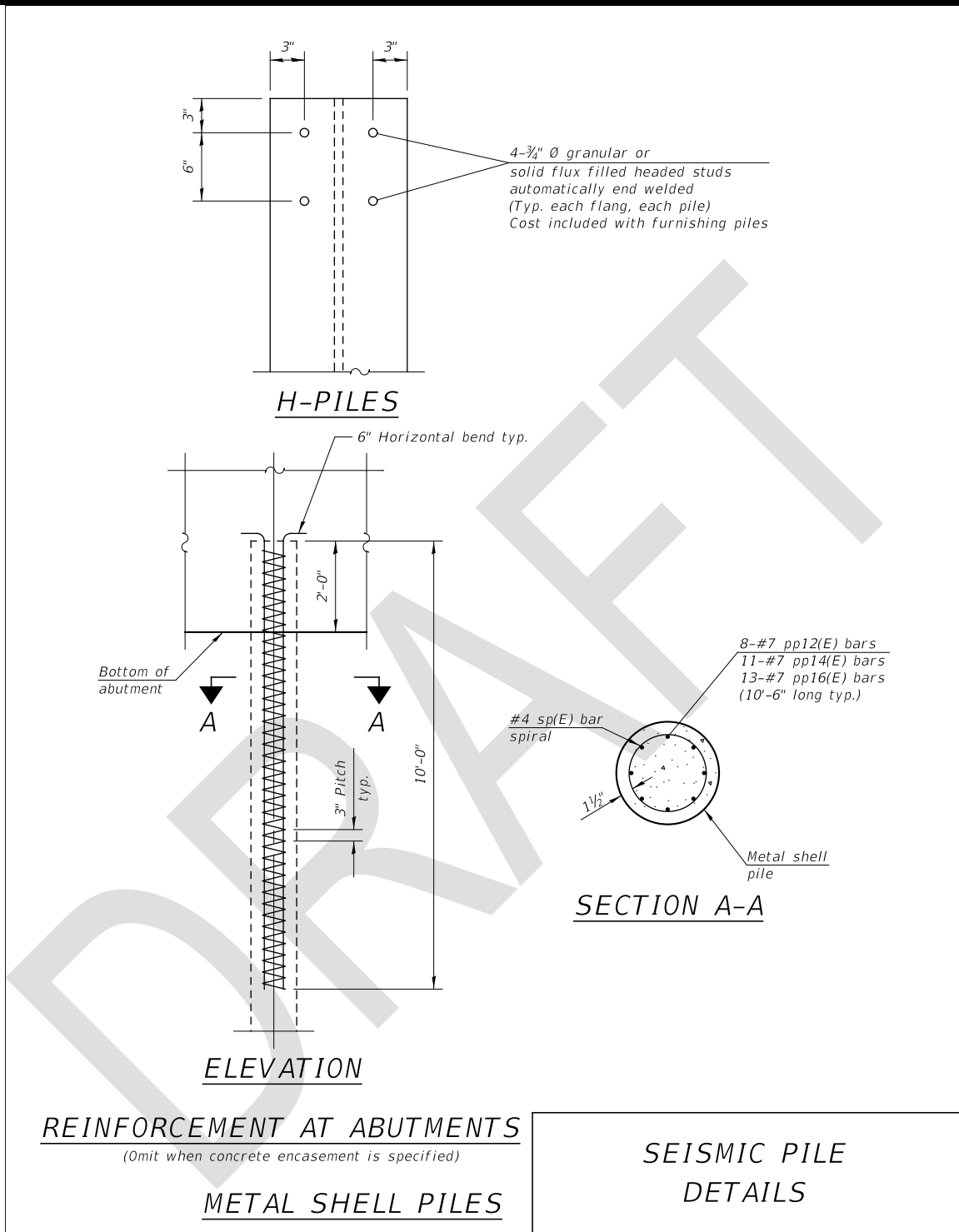
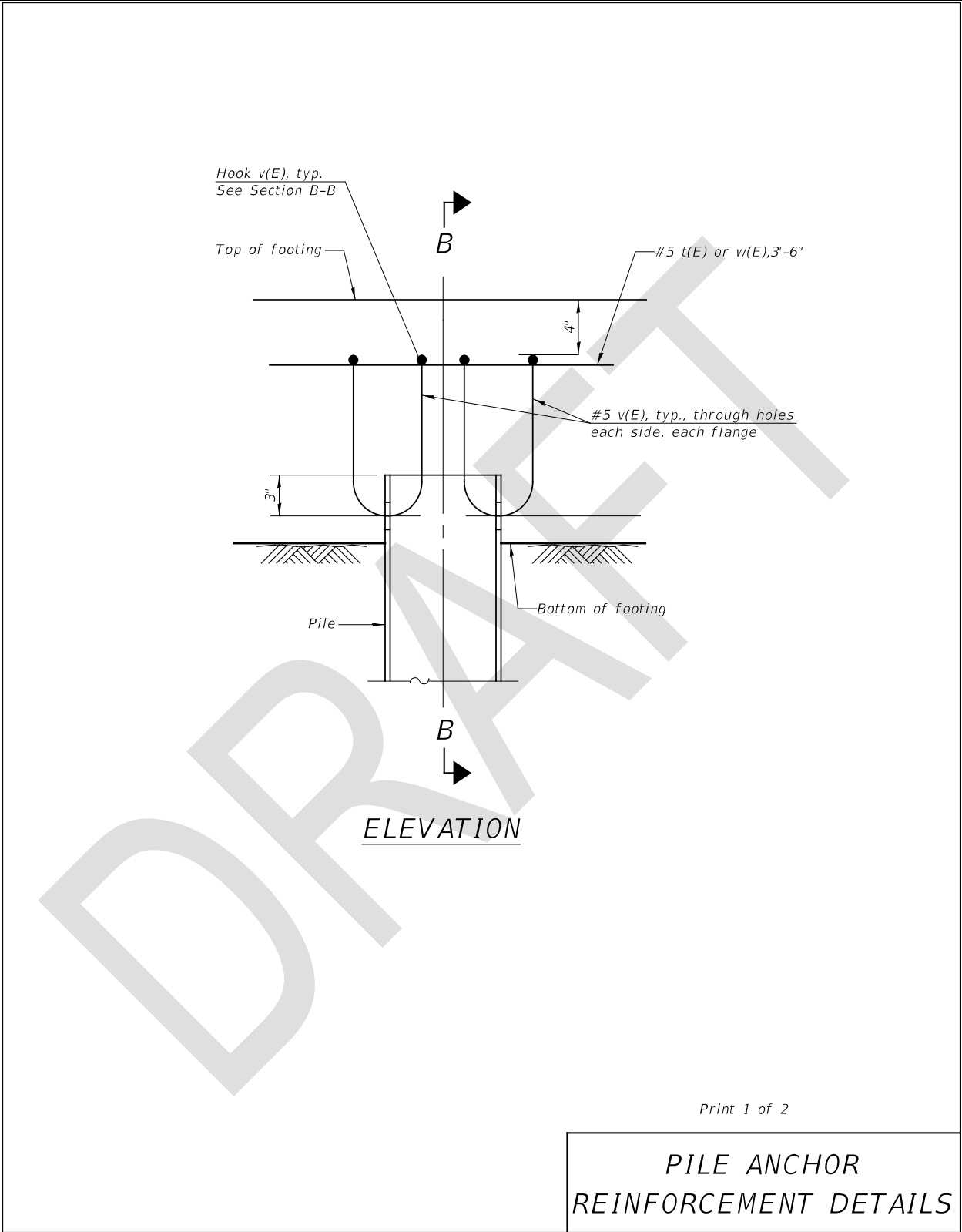

Figure 8.13-1



Print 1 of 2

PILE ANCHOR  
REINFORCEMENT DETAILS

Figure 8.13-2



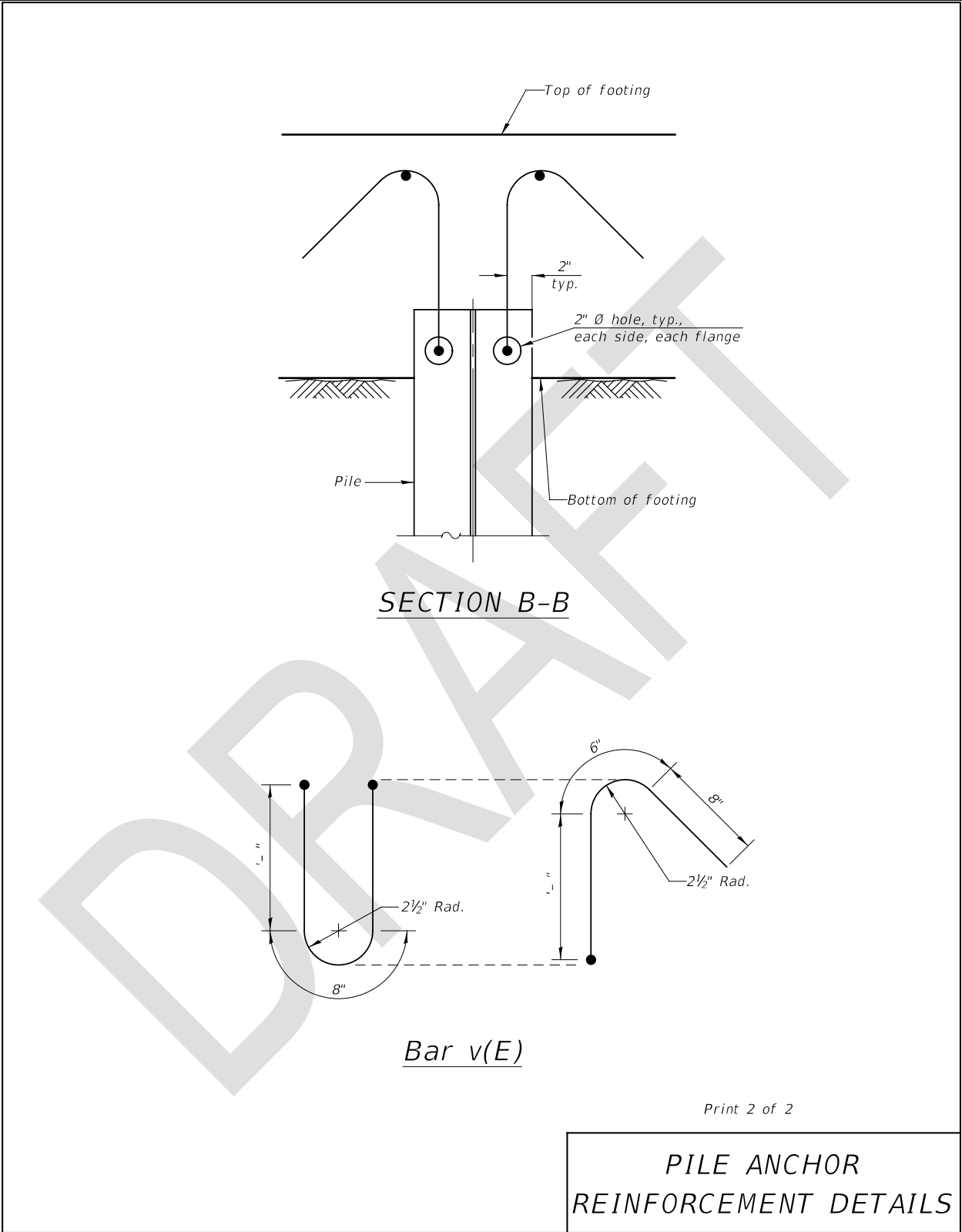

Figure 8.13-3

**8.14 Abutment and Backfill Treatments**

There are no additional seismic detailing requirements for abutment treatments in SDC A.

Figure 8.14-1 shows backfill and abutment treatments for bridges in SDB B, C, and D. The backfill wedge shape is consistent with the passive pressure zone shown in Figure 5.2.3.2-1 of the Guide Specifications, allowing for use of the soil stiffness formulas found in that article. The backfill gradations shall be CA-7, CA-11, or CA-14. These gradations are consistent with gradations found in FHWA Publication No. FHWA-HRT-13-068, allowing for an angle of internal friction of 50 degrees to be used when calculating passive soil stiffness.

To increase friction between the backwall and backfill, abutment backwalls shall be coated with coal tar pitch, allowing for a friction angle of 30 degrees to be assumed.

For wingwalls parallel to skew e.g. “dog-ear” wingwalls, the granular backfill for structures shall extend to 2'-0" from the end of wingwalls. For wingwalls parallel to traffic e.g. those used with stub abutments, the granular backfill for structures shall extend from the inside face to inside face on wingwalls.

Details for backfill and abutment treatments are found in Figures 8.14-1 and 8.14-2.

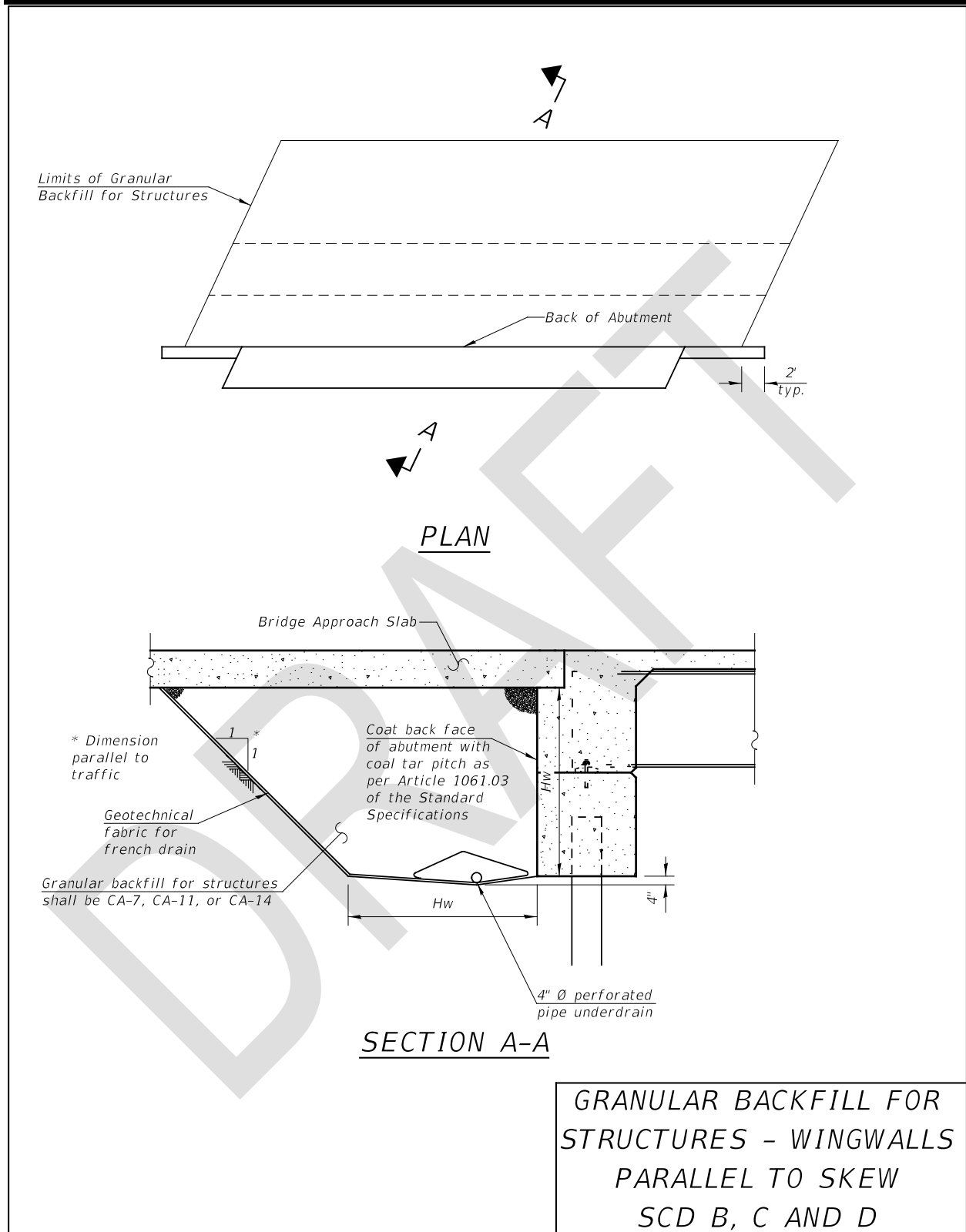

Figure 8.14-1

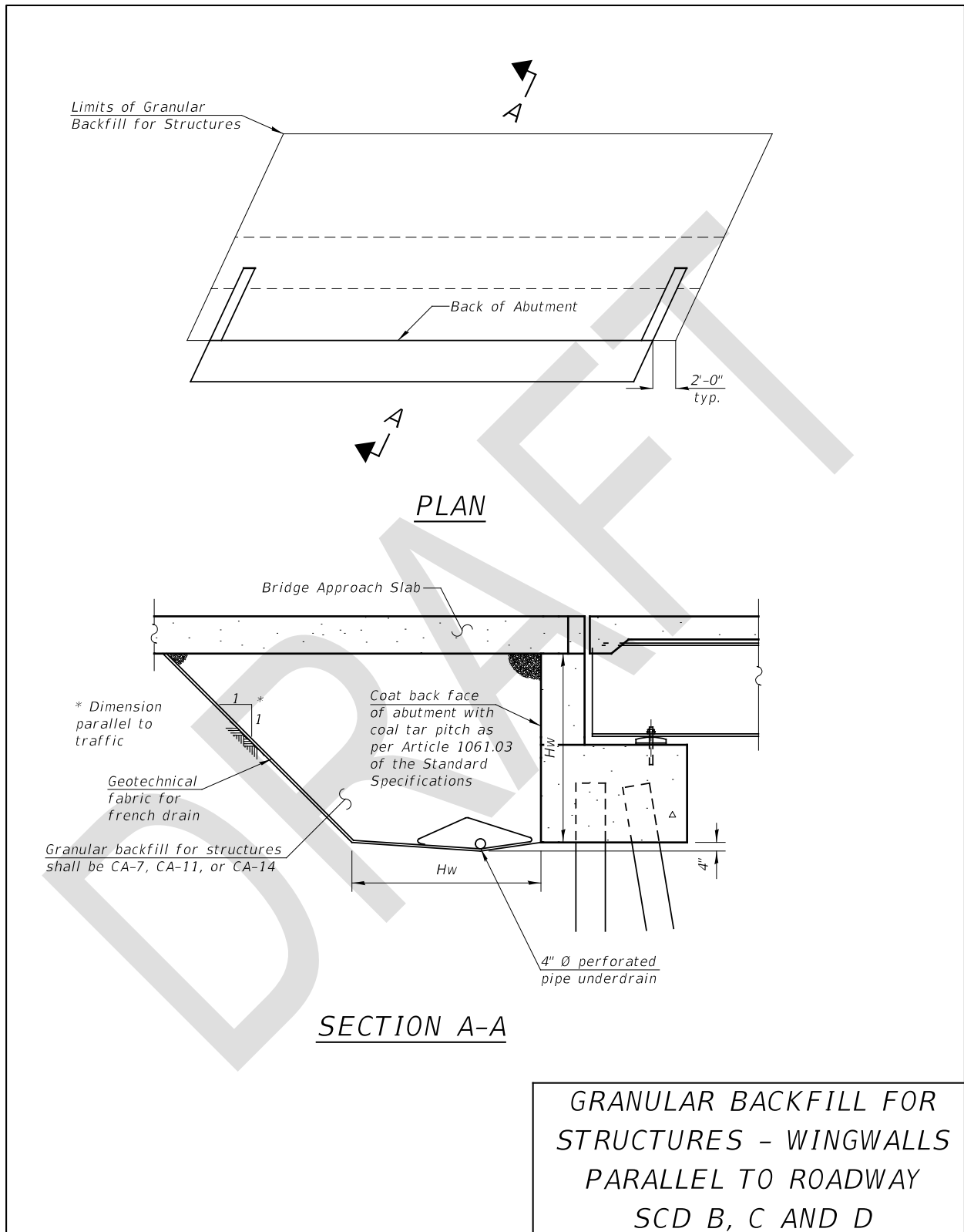

Figure 8.14-2

DRAFT



# **Section 9 Retrofitting of Existing Structures**

Reserved.

DRAFT

DRAFT



# **Section 10 Appendix**

Reserved.

DRAFT

DRAFT