

Atmospheric Neutral Density Experiment (ANDE-2) Flight Hardware Details

Andrew C. Nicholas, *
Ted Finne, †
Mark A. Davis, ‡
Robert Kessel, §

May 26, 2009

Overview

The ILRS community has requested particular documentation for all missions that the laser stations support. The main purpose of this document is to be the repository of the raw measurements supporting this request for the ANDE-2 mission (Figure 1).

These encompass the technical requirements for the laser based tracking and the target corrections to full exploit the data accuracy, precision, signature to further the science benefit of the field measurements[1].

The explicit questions of the ILRS mission support request form are detailed in the first section. The units of measure are explicitly metric in this section. The following sections and appendices are ancillary raw information from the as measured datasets. These data values in were measured and reported in English units. The value to be added to SLR measurements to construct the range to the geometric center of CASTOR is 225.0 mm and for POLLUX is 223.98 mm. The mass of the CASTOR is 47.45 kg. The mass of the POLLUX is 27.442 kg. The difference between the center of mass and geometric center has radius bounded by 6.35 and 5.0 mm respectively. The sensors onboard should permit attitude correctors to compute corrections in analysis. There are no consumables, however there are liquids in the battery cells which are mounted orthogonally between the spheres.

The basis for the design of the retroreflector arrangement and mounting are based on the ANDERR (ANDE Risk Reduction Mission) launched on STS-116 in 2006 [2].

The spheres are deployed on the NASA Shuttle Endeavour on STS-127 in June 2009 after visiting the International Space Station. Initial orbit is 10s of km lower than the station (340 km and 51.6 degree inclination). The deployment is from the CAPE system which has five objects spring separated from each other many seconds after leaving the cargo bay as shown in Figure 2. This deployment mechanism puts an intentional spin on the two spheres called CASTOR and POLLUX of approximately 1.6 and 2.4 degrees per second. The other 3 objects of the deployment system decay within a few months due to their larger area and smaller mass. The two spheres are covered in retro reflectors and have active electronics to measure and monitor the neutral atmosphere. There are battery systems onboard and the ability to monitor the attitude of each sphere and perform reorientations to put sensors into the ram direction and change the spin rate. There is no electrical recharge capability which limits the active life to around a dozen months. Details of the interior instruments are shown in the Poznan Poster[6] and several AAS workshops.

*Naval Research Laboratory, Code 7607, Thermospheric and Ionospheric Research and Applications Group, Washington D.C. 20375

†Naval Research Laboratory, Code 7607, Praxis Inc, Alexandria, VA 22303

‡Naval Research Laboratory, Code 8123, Electro-Optics Technology Section, Honeywell Technology Solutions, Inc., Washington D.C. 20375

§Naval Research Laboratory, Code 8123, Electro-Optics Technology Section, Washington D.C. 20375



Figure 1: The ANDE-2 LOGO

Summary of LRA information

This Section details the data requested in the ILRS mission support request form. The Section III questions are answered in the following paragraphs. Details for each of the sections requiring detailed discussion are in the remaining sections to generate the formal uncertainty in the measurements.

- QUESTION 1) Array type (spherical, hexagonal, planar, etc.), to include a diagram or photograph.
- ANSWER 1) Arrays are 19.0 inch spherical objects with photos shown in Figure 3. Each spacecraft is fitted with a set of thirty 12.7 mm diameter optical retro reflectors for SLR located along latitude bands at ± 90 deg, ± 52.5 deg, and ± 15 deg with one, six and eight retroreflectors per band respectively.

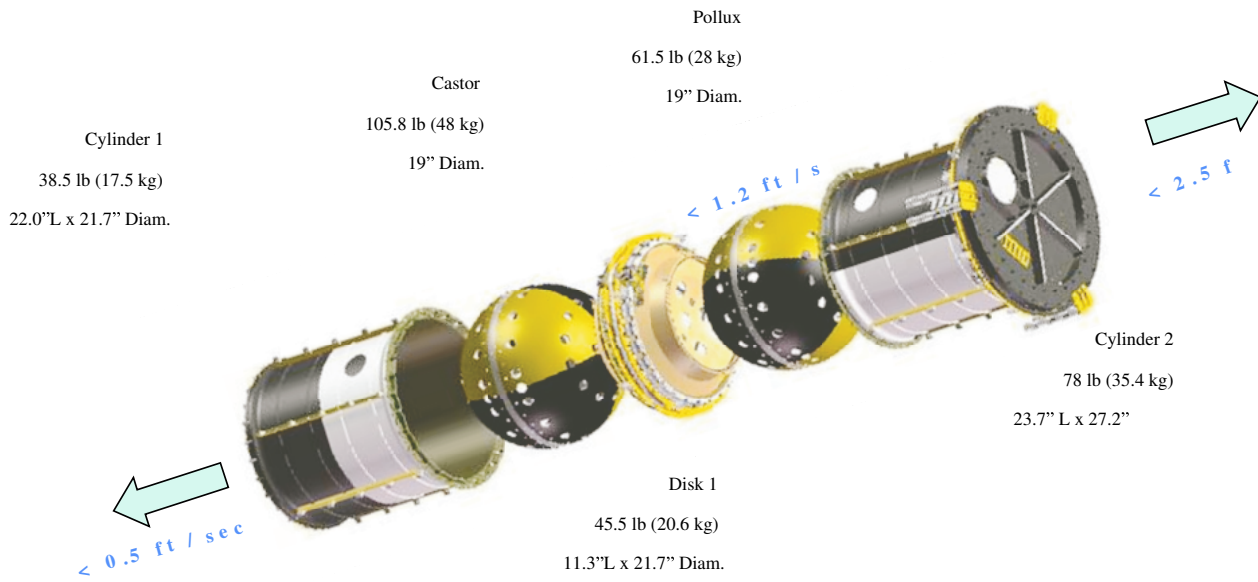

Figure 2: The ANDE-2 Deployment system from the Space Shuttle Cargo Bay (Masses are CDR estimates)

QUESTION 2) Array manufacturer.
 ANSWER 2) Array is an US Naval Research Laboratory (NRL) custom design by the Naval Center for Space Technology and with implementation and fabrication by the NRL Space Sciences Division. This is the same orientation design as the two ANDERR spheres and several Starshine flights.

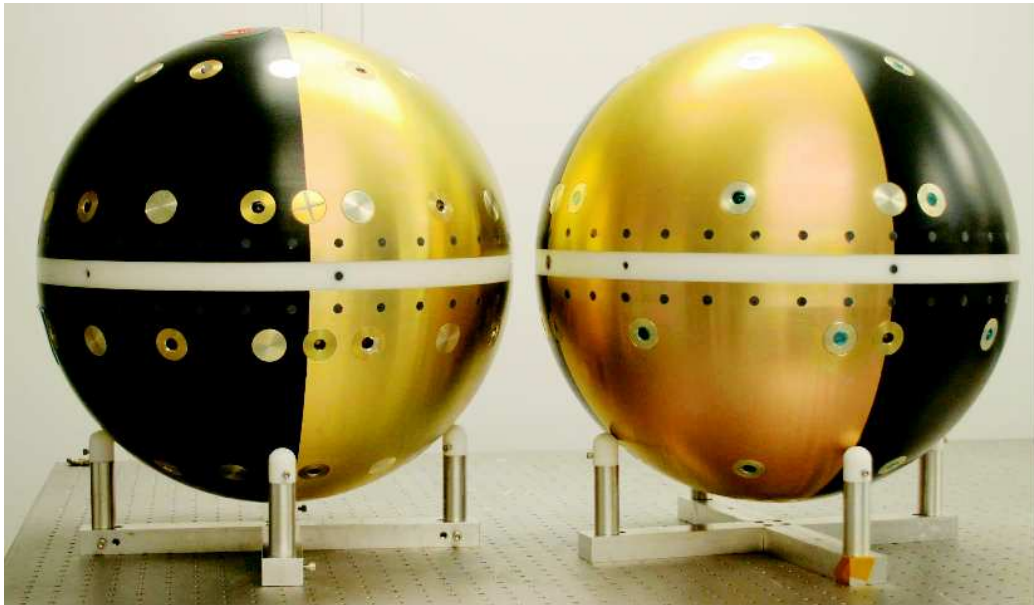

Figure 3: The ANDE-2 Spheres CASTOR (left) and POLLUX (right).

QUESTION 3) Link (URL or reference) to any ground-tests that were carried out on the array.

ANSWER 3) Optical Ground testing on the array was not performed but the array is very similar that of Starshine3 and identical to the ANDERR MAA. Performance of the 30 cube design is demonstrated by Graz using the 2 KHz ranging capability and compared with the theoretical performance from the original design. The adjacent cube geometry is included for use in orientation research.

QUESTION 4) The LRA design and/or type of cubes was previously used on the following mission.

ANSWER 4) The LRA design and type of cubes is similar to that used on the Starshine 1 and Starshine 3 Missions. See Kessel et al.[3] and Figures 4 and 5. Analytically derived mean cross section is from $0.1 \text{ e}6 \pm 0.05 \text{ e}6 \text{ meters}^2$. This was same design was flown on the ANDERR MAA (Active) and ANDERR FCAL (Passive) spheres.

QUESTION 5) The 3-D location (possibly time-dependant) of the satellite's mass centre relative to a satellite-based origin.

ANSWER 5) The 3D location of the center of mass is shown in Figures 6 and 7 and is bounded by 6.4 and 5.0 millimeters if orientation is ignored.

QUESTION 6) The 3-D location of the phase centre of the LRA relative to a satellite-based origin.

ANSWER 6) The optical phase center to satellite origin is 225.0 mm for the CASTOR and 223.98 mm for POLLUX. The relationship to center of mass origin will require attitude information.

Retro Map:

North

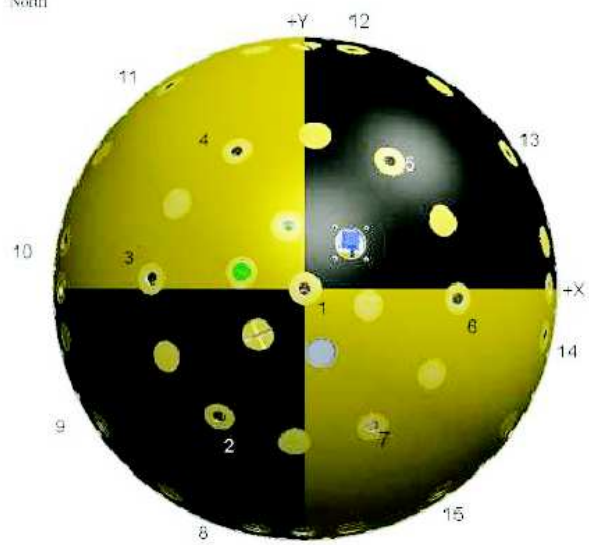

South

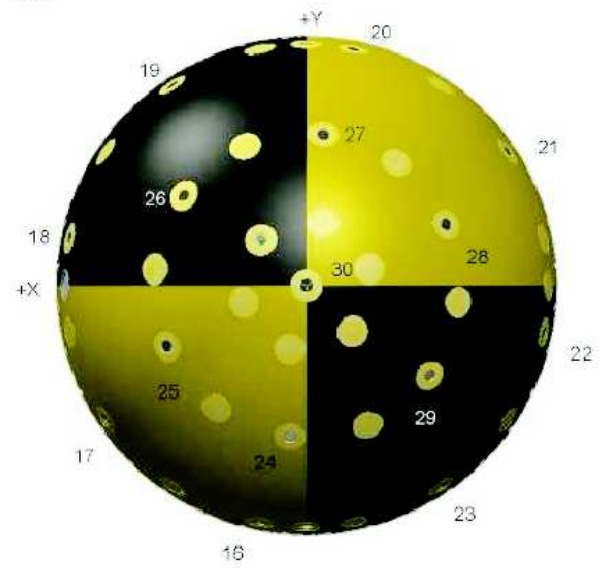
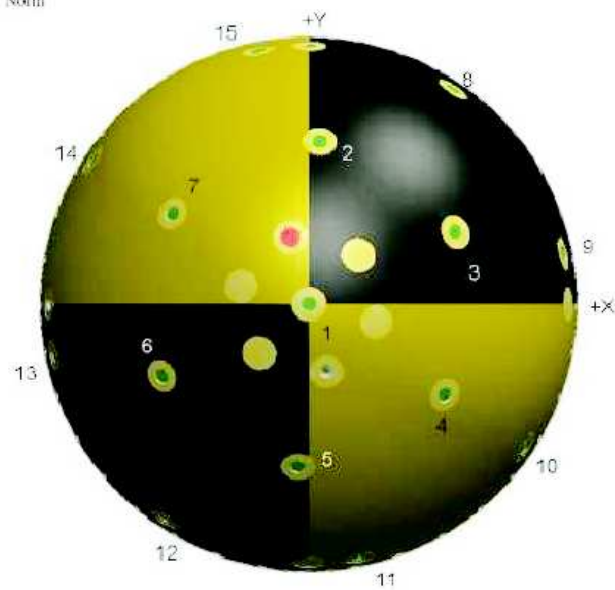

Figure 4: The CASTOR retroreflector numbering convention.

North



South

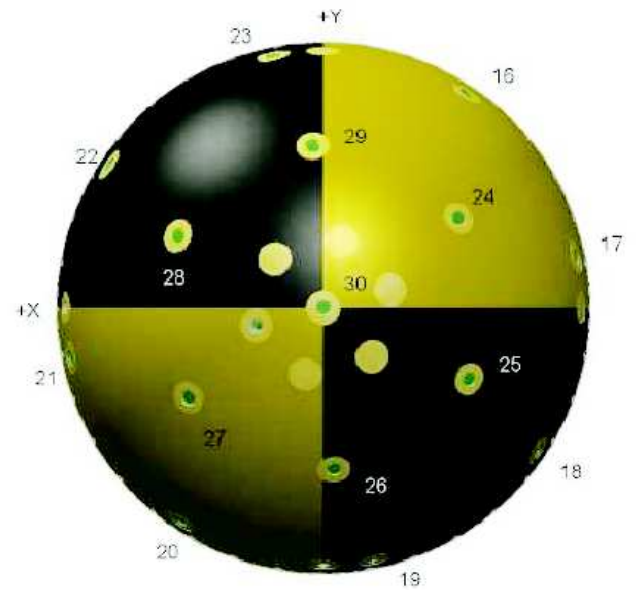

Figure 5: The POLLUX retroreflector numbering convention.

Mass Properties (measured):

1. Mass
 - a. 104.61 lbf
2. Cg offset from geometric center of sphere (inches)
 - a. +.131 X
 - b. -.131 Y
 - c. -.168 Z
3. MOI's (lb-in²)
 - a. 4104.1 Ixx
 - b. 3594.9 Iyy
 - c. 3916.1 Izz

North Hemisphere		South Hemisphere	
Retro ID	Angle wrt +Z	Retro ID	Angle wrt -Z
1*	55	16*	18
2	29	17	-19
3	-10	18	-10
4	-11	19	-42
5	-21	20	44
6	34	21	8
7	-42	22	32
8	-42	23	5
9	18	24	47
10	-28	25	72
11	0	26	44
12	-9	27	-43
13	-46	28	-20
14	5	29	-30
15	-36	30	60

* wrt +X

Figure 6: The CASTOR retroreflector cube clocking (degrees).

Mass Properties (measured):

1. Mass
 - a. 60.5 lbf
2. Cg offset from geometric center of sphere (inches)
 - a. +.113 X
 - b. -.113 Y
 - c. -.115 Z
3. MOI's (lb-in²)
 - a. 2338.4 Ixx
 - b. 2329.1 Iyy
 - c. 2904.3 Izz

North Hemisphere		South Hemisphere	
Retro ID	Angle wrt +Z	Retro ID	Angle wrt -Z
1*	-15	16*	55
2	-26	17	-29
3	43	18	63
4	-40	19	60
5	-13	20	0
6	-17	21	-48
7	-43	22	-40
8	-20	23	69
9	32	24	-57
10	14	25	-5
11	-26	26	72
12	58	27	-9
13	-11	28	-37
14	-15	29	35
15	-21	30	62

* wrt +X

Figure 7: The POLLUX retroreflector cube clocking (degrees).

- QUESTION 7) The position and orientation of the LRA reference point (LRA mass-centre or marker on LRA assembly) relative to a satellite-based origin.
- ANSWER 7) The position of the LRA reference to the satellite origin is dependant on the orientation of the sphere. Each of these are included in Figures 6 and 7. The mass properties have been included for long term spin vector determination. Each sphere is instrumented and measured telemetry will be available for analysis and correlation to SLR derived values (when the spin rate is high). The offset from the geometric sphere and the center of mass is (3.33, -3.33, -4.27) millimeters for the CASTOR sphere and (2.87, -2.87, 2.92) for the POLLUX sphere. This variation is 6.4 and 5.0 mm respectively.

cube number	X (mm)	Y (mm)	Z (mm)	rss (mm)
1	0.00	0.00	240.46	240.46
2	81.33	121.71	190.77	240.46
3	146.07	-9.57	190.77	240.46
4	64.74	-131.29	190.77	240.46
5	-81.33	-121.71	190.77	240.46
6	-146.07	9.57	190.77	240.46
7	-64.74	131.29	190.77	240.46
8	45.31	227.80	62.24	240.46
9	193.12	129.04	62.24	240.46
10	227.80	-45.31	62.24	240.46
11	129.04	-193.12	62.24	240.46
12	-45.31	-227.80	62.24	240.46
13	-193.12	-129.04	62.24	240.46
14	-227.80	45.31	62.24	240.46
15	-129.04	193.12	62.24	240.46
16	-49.28	226.98	-62.24	240.46
17	-195.35	125.65	-62.24	240.46
18	-226.98	-49.28	-62.24	240.46
19	-125.65	-195.35	-62.24	240.46
20	49.28	-226.98	-62.24	240.46
21	195.35	-125.65	-62.24	240.46
22	226.98	49.28	-62.24	240.46
23	125.65	195.35	-62.24	240.46
24	-18.47	145.21	-190.77	240.46
25	-135.00	56.61	-190.77	240.46
26	-116.52	-88.61	-190.77	240.46
27	18.47	-145.21	-190.77	240.46
28	135.00	-56.61	-190.77	240.46
29	116.52	88.61	-190.77	240.46
30	0.00	0.00	-240.46	240.46
cm	3.33	-3.33	-4.27	6.35

Table 1: CASTOR retroreflector center of aperture locations

QUESTION 8) The position (xyz) of either the vertex or the centre of the front face of each corner cube within the LRA assembly, with respect to the LRA reference point and including information of amount of recession of the front faces of cubes.

ANSWER 8) The center of the aperture of each reflector is shown in Tables 1 and 2. The center of the cube aperture recession below the theoretical 19 inch spherical surface for CASTOR is 240.46 mm. This same value for POLLUX is 239.42 mm. The diameter of the hole exposing the aperture is 10.67 mm centered about the vertex aperture axis. The POLLUX cubes have a 1 mm thick aperture filter which passes 532 nm at greater than 98%. Details of this optical filter are in the Figure 8. Note that the reported value is different than the documentation of the ANDERR mission where the reported value was the vertex of each cube.

cube number	X (mm)	Y (mm)	Z (mm)	rss (mm)
1	0.00	0.00	239.42	239.42
2	9.53	145.44	189.94	239.42
3	130.72	64.46	189.94	239.42
4	121.19	-80.97	189.94	239.42
5	-9.53	-145.44	189.94	239.42
6	-130.72	-64.46	189.94	239.42
7	-121.19	80.97	189.94	239.42
8	128.48	192.29	61.97	239.42
9	226.82	45.12	61.97	239.42
10	192.29	-128.48	61.97	239.42
11	45.12	-226.82	61.97	239.42
12	-128.48	-192.29	61.97	239.42
13	-226.82	-45.12	61.97	239.42
14	-192.29	128.48	61.97	239.42
15	-45.12	226.82	61.97	239.42
16	-128.48	192.29	-61.97	239.42
17	-226.82	45.12	-61.97	239.42
18	-192.29	-128.48	-61.97	239.42
19	-45.12	-226.82	-61.97	239.42
20	128.48	-192.29	-61.97	239.42
21	226.82	-45.12	-61.97	239.42
22	192.29	128.48	-61.97	239.42
23	45.12	226.82	-61.97	239.42
24	-121.19	80.97	-189.94	239.42
25	-130.72	-64.46	-189.94	239.42
26	-9.53	-145.44	-189.94	239.42
27	121.19	-80.97	-189.94	239.42
28	130.72	64.46	-189.94	239.42
29	9.53	145.44	-189.94	239.42
30	0.00	0.00	-239.27	239.27
cm	2.87	-2.87	2.92	5.00

Table 2: POLLUX retroreflector center of aperture locations

QUESTION 9) The orientation of each cube within the LRA assembly (three angles for each cube).

ANSWER 9) The orientation for each cube is radially outward. These are constructed so that the aperture is normal to the tangent of the sphere at each location. Each cube was measured in orientation with respect to the polar coordinate system with +/- Z aligned with the N/S poles. Each cube back face intersection is measured with respect to the longitude lines at each cube and shown in Figures 6 and 7. Tolerance of this measurement is better than a degree in orientation.

QUESTION 10) The shape and size of each corner cube, especially the height.

ANSWER 10) The size and shape of each corner cube is shown in Figure 9, is Edmund PN SP-45-202. The height of these 10.2 mm COTS retro reflectors is measured to be 10.16 mm with + or - 0.25 mm uncertainty. Tolerance of this measurement is better than a degree in orientation.

CG-BG-40
CG-BG-39

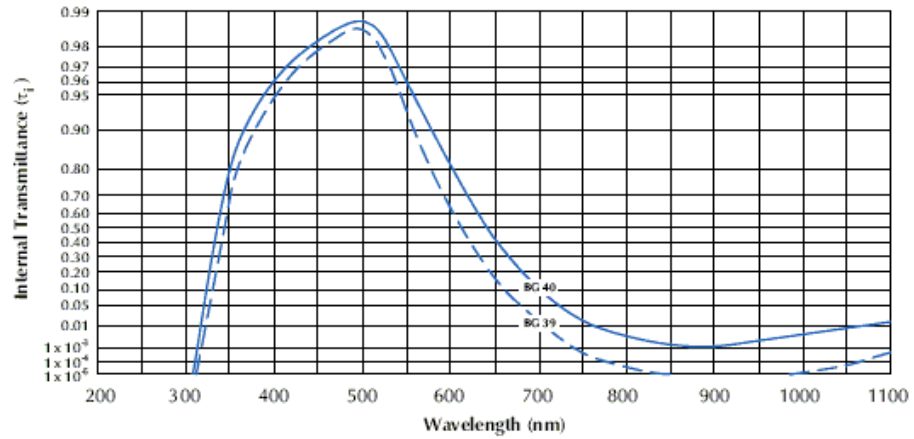

Internal transmittance $\tau_i(\lambda)$ for 2mm glass thickness. Graph courtesy of Schott Glass Technologies, Inc. Other thicknesses are also available. For transmittance values at other thicknesses, please contact CVI.

Curve is for 2 mm sample – ANDE Pollux is 1 mm thick

Figure 8: The spectral transmission of a 2 mm thick POLLUX aperture filter (BG-39).



Figure 9: The type of retroreflectors.

- QUESTION 11) The material from which the cubes are manufactured (e.g. quartz).
- ANSWER 11) The material for each corner cube is BK7. The POLLUX sphere contains additional CVI band pass BG-39 filters centered at 532 nm.
- QUESTION 12) The refractive index of the cube material, at a range of wavelengths.
- ANSWER 12) The refractive index of the cube material BK7 is 1.53815 for 355 nm, 1.52805 for 423.5 nm 1.51947 for 532 nm, 1.50991 for 847 nm, 1.50663 for 1064 nm, 1.50059 for 1555 nm. For reference the commonly used fused silica index variation would be 1.47607, 1.46782, 1.46071, 1.45256, 1.44963 and 1.44396 respectively.
- QUESTION 13) Dihedral angle offset(s) and the manufacturing tolerance.
- ANSWER 13) The Dihedral angle offsets are zero with a manufacturing tolerance such that the beam deviation is less than + or - 3 arc seconds. These were not confirmed by independent quality control process beyond industry practice at Edmund.
- QUESTION 14) Radius of curvature of the front surfaces of cubes if applicable.
- ANSWER 14) The radius of curvature of the aperture of the cubes is infinity. There is no intended power from the aperture on these retroreflectors.
- QUESTION 15) Flatness of cubes surfaces (as a fraction of wavelength).
- ANSWER 15) The flatness of the cubes surfaces (as a function of 633 nm light) is such that after the three back faces and two aperture crossings the beam remains $\lambda/8$.
- QUESTION 16) Whether or not the cubes are coated and with what material.
- ANSWER 16) The aperture of the cubes are coated with the Edmund Custom V2 (532 and 1064) anti-reflection coating. The back faces have vacuum deposited silver with an inconel and black over paint.

Flight Hardware Overview of the ANDE-2 (Questions 1,2,3)

There were a total of 5 components deployed as an Internal Cargo Unit (ICU) from the NASA STS-127 Endeavour Flight shown in Figure 2. This deployment object will not be spinning about the long axis of the cylinder (ICU) and is separated from the Cargo Bay with ΔV in the range 0.89 meters per second in the negative velocity direction. The ICU system of 5 components will separate approximately 30 seconds later into components Cylinder1, CASTOR, Disk1, POLLUX, Cylinder2, under spring forces using a light band deployment systems as shown in Figure 2. There is a planned delay between the half which imparts a cross-track component to the CASTOR sphere. Under a nominal deployment the CASTOR sphere will be spinning a 1.6 degrees per seconds and the POLLUX will be 2.4 degrees per seconds. This is equivalent to 0.27 and 0.40 revolutions per minute. Confirmation using ground techniques will be desired days after deployment. There will be high definition video for the first few minutes for accurate comparison. The spin is required on the ANDE-2 flight for the accurate sensing of the species constituents and the thermal control of the various sensors. There is the ability to actively respin the spheres and SLR data is the unique technique to measure this change and confirm the inertial direction of the spin vector. The ILRS nomenclature for the CASTOR and POLLUX will be ANDEC (CASTOR) and ANDEP (POLLUX) for the CPF prediction names. The CASTOR sphere has COSPAR 090XXXX, catalog *TBD*, and SIC 1073. The POLLUX sphere has COSPAR 090XXXX, catalog *TBD*, and SIC 1074.

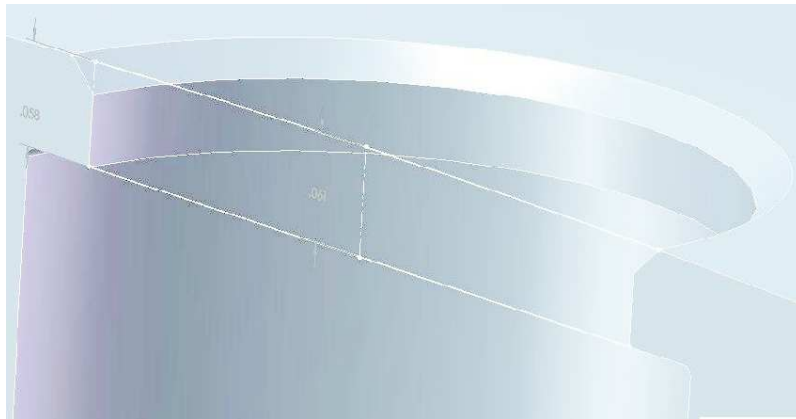

Figure 10: The retroreflector aperture is recessed below the surface 1.52 mm (0.058 inches).

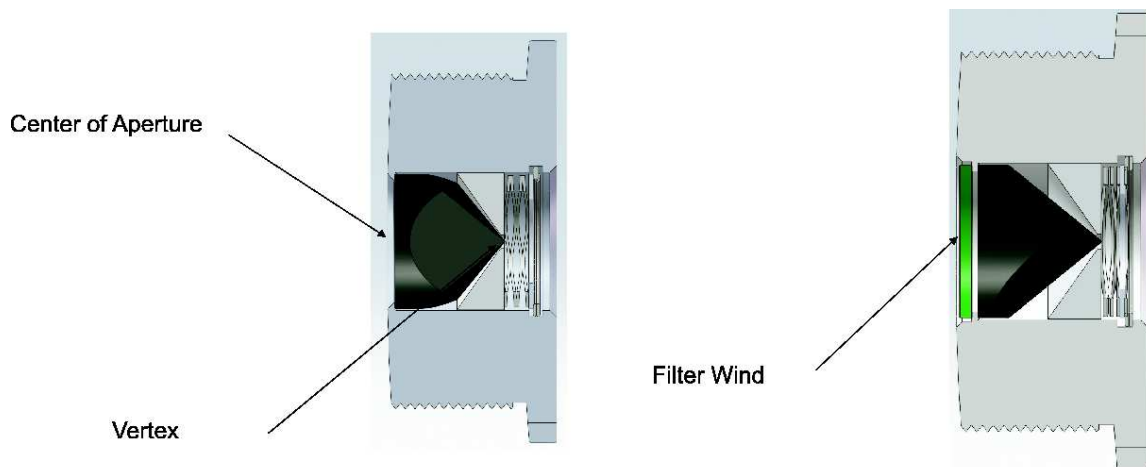

Figure 11: The retro holder and details of the CASTOR cube (left). The retro holder and details of the POLLUX cube and IR filter window(right).

Retro Reflectors and corrections the ANDE-2 CASTOR and POLLUX (Questions 4 through 16)

There are thirty retro reflectors on each sphere in an orientation of $\pm 90^\circ$, $\pm 52.5^\circ$ and $\pm 15^\circ$ from the equator, with one, six and eight retroreflectors per band respectively. The retro reflectors are Edmund Optics NT45-202 12.7 mm prism corner cubes as shown in Figure 9. These have aperture to vertex (height) distances for 10.16 mm. The exposed aperture is 0.42 inches (10.67 mm) diameter. After mounting in the universal holder, the optical testing did not include metric performance testing. These holders then threaded from the inside of the sphere. The aperture of each reflector is (0.058 inches) below the holder lip as shown in Figure 10, which has negligible impact on the theoretical incidence angle functionality and cross section. Details of the mounting are shown in expanded view Figures 11, and 12. The retroreflector spatial design (number and orientation) is a reuse of that used on the Starshine flights and consists of 30 reflectors on a sphere providing overlap and cross section shown in Figure 13. Estimates of the 532nm optical cross section of this design exceed 0.05 Million square meters in the worst orientation with more typical values near 0.12. The use of the COTS retro reflectors has been used successfully by NRL on other very LEO missions and the tolerancing and non-rad-hard substrates are a research area but not expected to degrade over the short lifespan of these satellites.

The aperture coatings on each reflector is the 2V (532 and 1064 nm) COTS anti-reflective product from

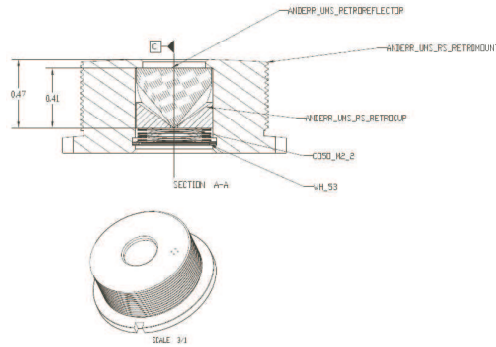

Figure 12: The retro holder and sphere surface (inches).

Edmunds. The back faces are vacuum deposited silver with inconel and black over paint. The orientation of each reflector is radially outward, with aperture center of each reflector located at positions shown in Tables 1 and 2. The number of significant digits in the inches columns is directly from the 3-d modeling software. The metric and computed radius and dispersion are numerically derived from the inches measurements. The as-built hardware generally agrees with the design model to ± 0.38 mm (or ± 0.015 inches). These have mean values of 240.46 and 239.42 mm for CASTOR and POLLUX respectively. Given that the aperture to vertex distance is 10.16 mm and index of the BK7 material at 532 nm is 1.51947, the optical phase center will be 15.43 mm inside the sphere of aperture center locations. The value to be added to SLR measurements to construct the range to the geometric center of CASTOR is 225.0 mm and for POLLUX is 223.98 mm.

It should be noted that the center of mass of each object is slightly offset from the frame used for measuring the vertex locations by at most 6.4 millimeter and that spin rate and orientation would need to be modeled for any improvements. Some of this orientation data will be in the experimental data that is downlinked and available from mission data center.

Most of the design was done using English units with mechanical tolerancing being ± 15 mils. The metric equivalent (0.38 mm) have been included for the reader and were in most all cases derived.

Figures 14 and 15 illustrate the predicted link budget for each laser shot and the measured data yield per normal point from the ANDERR flight. These plots include data from all of the ILRS sites including the 5 Hz and 2000 Hz stations. All passes are shown and normalized to the rangerate. Middle of the overflight is at zero. Horizon at the rise of the pass is as -7000 meters/second.

Mass Properties

The outer shell diameter for the 6060-T6 cast aluminum spheres are 19 inches.

The mass of the CASTOR is 104.61 lbf or 47.45 kg. The mass of the POLLUX is 60.5 lbf or 27.442 kg. The CASTOR center of gravity in the satellite xyz frame is at (3.33, -3.33, -4.27) mm. This value for POLLUX center of gravity is at (2.87, -2.87, 2.92) mm.

The diagonal elements (off axis terms are zero) of the CASTOR Mass moment of Inertia are (4104.1, 3594.9, 3916.1) inlbm-in². The equivalent for the POLLUX are (2338.4, 2329.1, 2904.3) inlbm-in².

Solar Reflection Details

These Spheres were manufactured and assembled at NRL using a variety of custom and cots components. The surface finish on the CASTOR and POLLUX is aluminum polished to 32 micro inches RMS, with black anodized and gold irridited identical to the MAA (Active) sphere in the ANDERR mission. The paint scheme of 8 quadrants of two varieties permits the measurement of solar flux variability and helps to control the temperatures of the interior instrumentation. The surface materials are identical for both spheres on the ANDE-2 flight. The plots in Figures 16 and 17 show the measured spectral reflectance for the POLLUX sphere [4]. The illumination source for the reflectance measurments shown in Figure 18 is a broad band integrating sphere kept NIST-traceable by NRL Code 7200. The spectra were measured with an ASD spectroradiometer using both 8° and 25° foreoptics. The plots are included for construction of the reflectance ratio between the surfaces and high fidelity solar radiation pressure models. The equivalent reflectance measurements for the prior ANDERR spheres are given in Abercromby[5].

Additional the Pixis sensors was used to perform a very systematic BRDF characterization of the surface performed by Welles, Glass and Whalen. These results are not published. Non-flight hemispheres and hardware exists with these coatings and holders with retros should further testing be desired.

Acknowledgment

The success of the ANDE-2 mission depends upon the observations and products of all the ILRS stations and coordinators. The support of all the contributions is gratefully acknowledged[1].

References

- [1] M.R. Pearlman, J.J. Degnan, J.M. Bosworth, “The International Laser Ranging Service”, *Advances in Space Research*, Vol. 30, No. 2, pp. 135-143, July 2002, DOI:10.1016/S0273-1177(02)00277-6.
- [2] Andrew C. Nicholas, Ted Finne, Mark Davis, “The Atmospheric Neutral Density Experiment (ANDERR) Hardware Details”, ILRS website 2006, ilrs.gsfc.nasa.gov/docs/anderr_hw.pdf.
- [3] Robert Kessel, William Braun, Mark Davis, Amey Peltzer, Anne Reed, Ilene Sokolsky, John Vasquez, Paul Wright, “Development and on-orbit performance of moderate-cost spherical retroreflector arrays for the Starshine program”, in R. Noomen, S. Klosko, C. Noll and M. Pearlman (Eds.), *Proceeding of the 13th International Laser Ranging Workshop, 2002*, **NASA/CP-2003-212248**, [tar_kr1m.pdf](#), 2003.
- [4] Robert Kessel, “February 12 2009 ANDE reflectance results”, internal NRL memo and lab notes.
- [5] Kira Abercromby, “Comparisons of Ground Truth and Remote Spectral Measurements of the FORMOSAT and ANDE Spacecraft”, *Proceedings of the 2006 AMOS Technical Conference*, Maui HI, Sept 2006, pages 728 to 737.
- [6] Andy Nicholas, “Atmospheric Neutral Density Experiment (ANDE) Mission Update”, Poster at the ILRS 16th Workshop, Poznan Poland, Oct 2008.
(After here, none of these references appear to be cited.)
ACTION add item poznan poster
ACTION add item aiaa workshop spring 2009
ACTION cite the ilrs basic paper
- [7] Andrew C. Nicholas, et. al, “The Atmospheric Neutral Density Experiment (ANDE)”, *Proceedings of the 2002 AMOS Technical Conference*, Maui HI, Sept 2002.
- [8] Andrew C. Nicholas, S. Tonnard, I. Galysch, P. Kalmanson, B. Bruninga, S. Ritterhouse, J. Englehardt, K. Doherty, J. McGuire, D. Niemi, H. Heidt, M. Hallada, “ANDE Risk Reduction Flight Observing Opportunities and Mission Update”, *Proceedings of the 2005 AMOS Technical Conference*, Maui, HI, Sept 2005.

- [9] Andy Nicholas, “Atmospheric Neutral Density Experiment (ANDE) Risk Reduction Mission”, Poster at the ILRS 15th Workshop, Canberra Australia, Oct 2006.
- [10] Andrew Nicholas, G. C. Gilbreath, S. Thonnard, R. Kessel, R. Lucke, and C. P. Sillman, “The Atmospheric Neutral Density Experiment (ANDE) and Modulating Retroreflector In Space (MODRAS): Combined Flight Experiments for the Space Test Program”, Proceedings of the SPIE Remote Sensing Conference, Agia Peligia, Crete, Greece, September 23-27 2002, Volume 4884, p49-58.

-LRCS calculated for:

- 1.2" dual coating 532 & 1064 nm
- Worst case pass shown: elevation 20°
- NASA MOBLAS laser ranging site efficiency

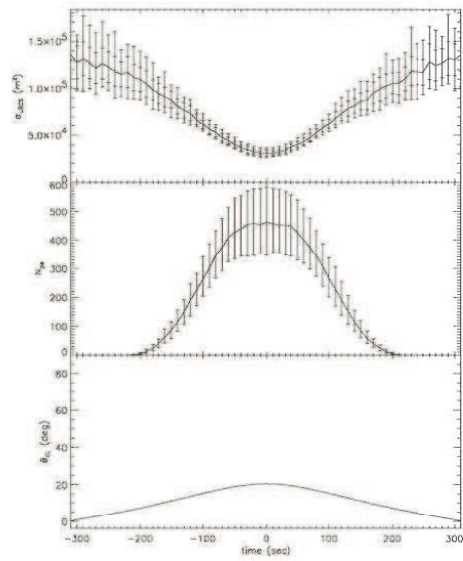
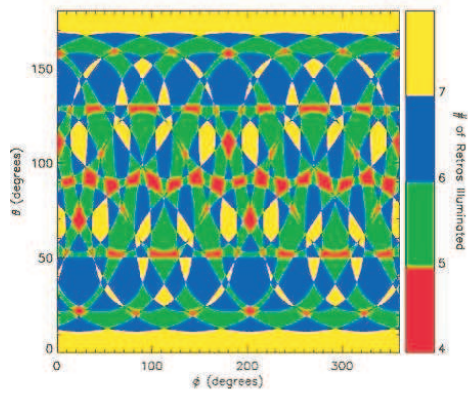

Figure 13: The LRCS and number of contributing reflectors and estimated link budget.

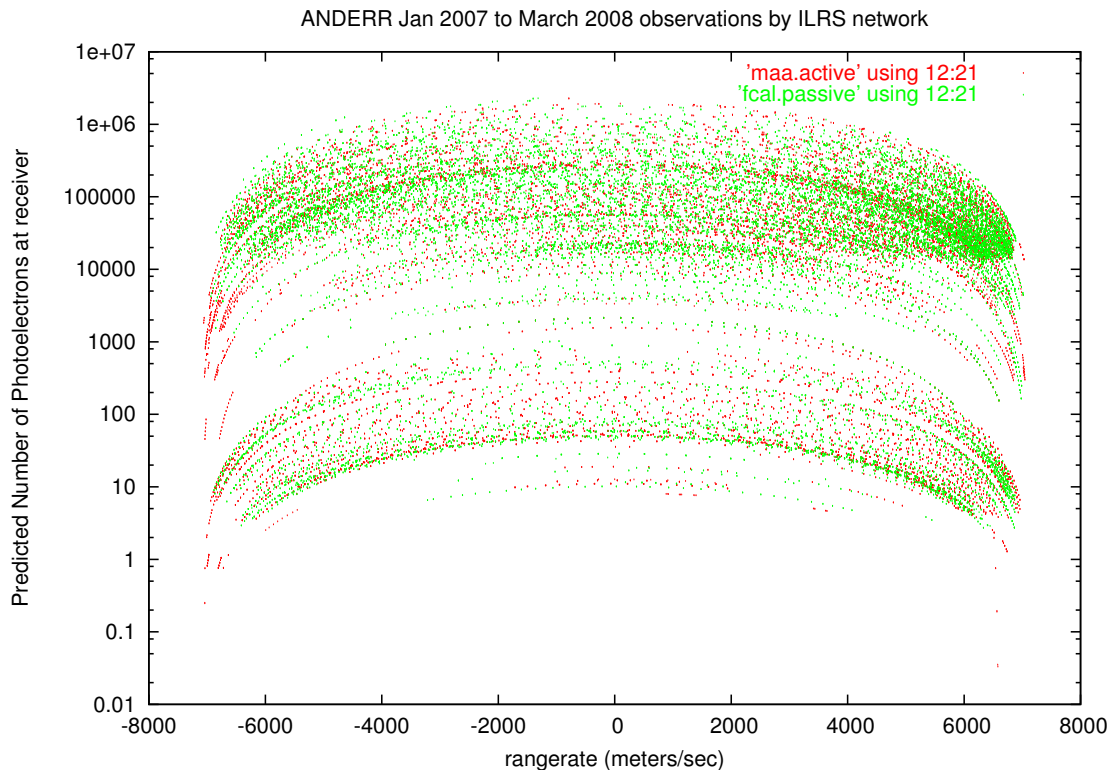

Figure 14: The ANDERR mission estimated link budget from observations

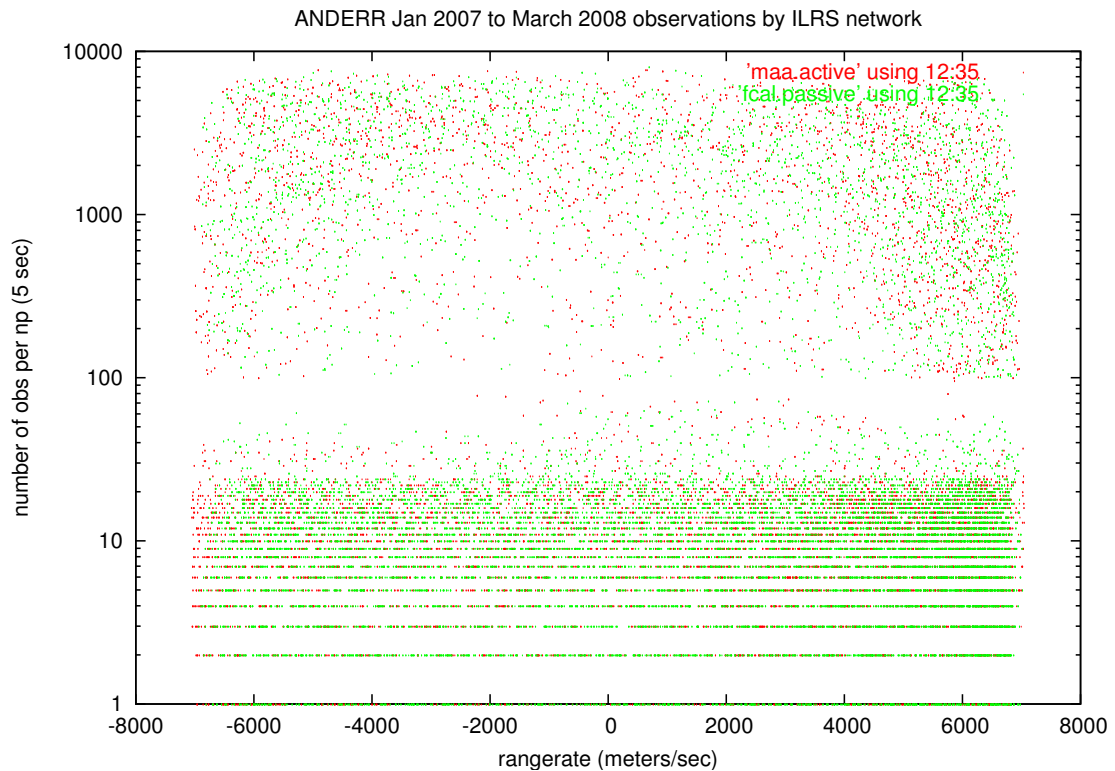

Figure 15: The ANDERR mission number of observations per normal point

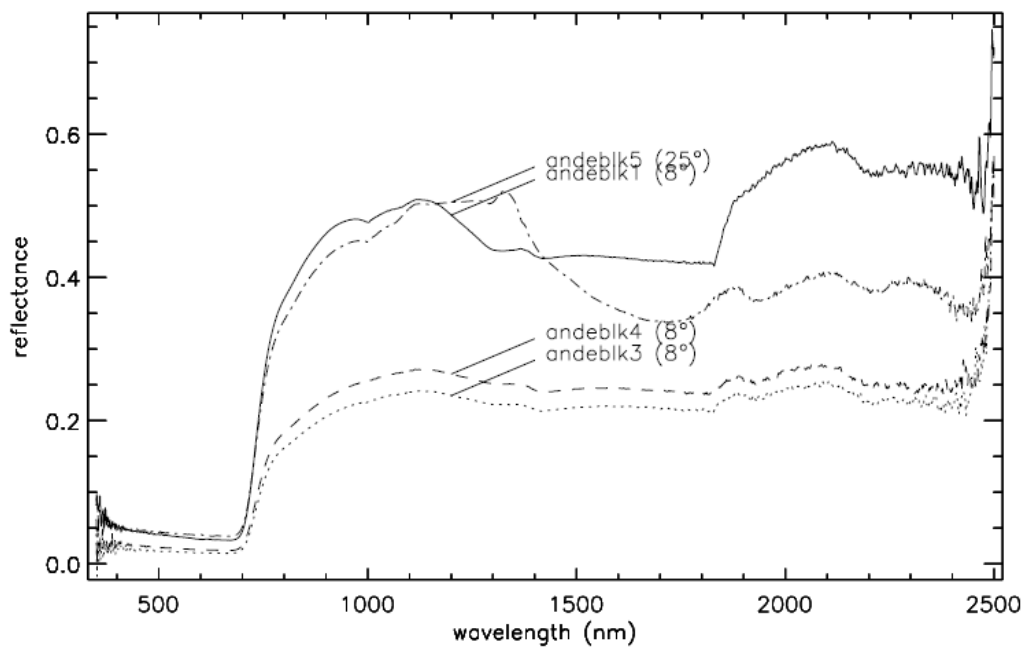

Figure 16: The spectral reflectance of the POLLUX black anodized surface in the VNIR band pass.

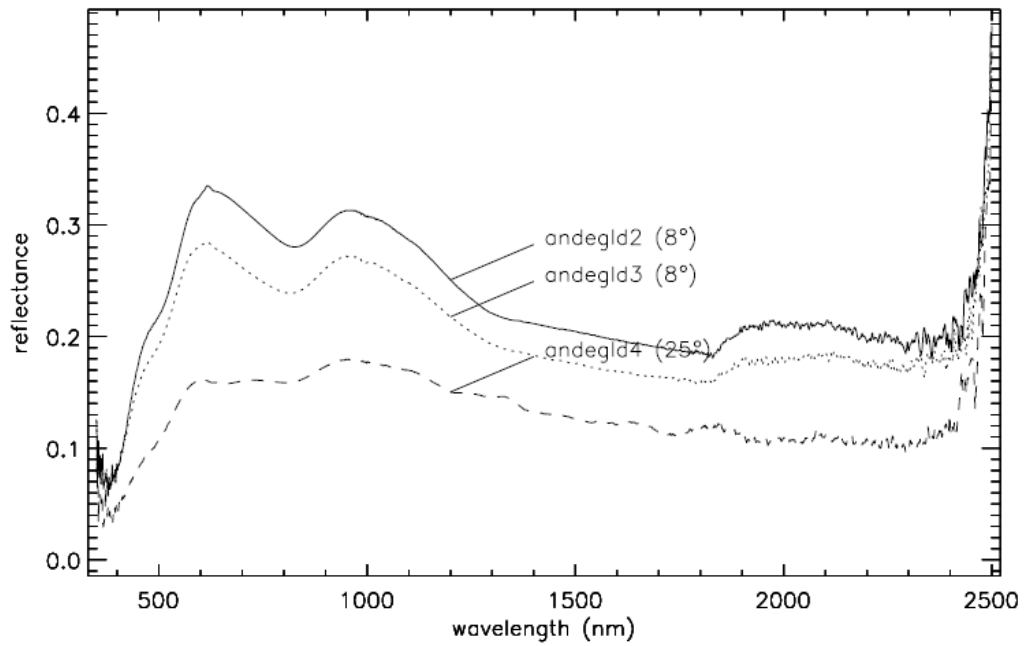

Figure 17: The spectral reflectance of the POLLUX gold irradiated surface in the VNIR band pass.



Figure 18: The spectral reflectance measurement setup for POLLUX.