

Alaska Railroad Corporation Load Manual



The ARRC reserves the right to make changes to this manual at any time. Please make sure to look up the most current version at www.alaskarailroad.com under Freight Services.

Revised 8-30-23

Table of Contents

Updates will be in red.

Table of Contents	2-3
ARRC General Tie Down Rules	4-6
Securement Items	
Blocking	7
Double Cut Wedge Blocks	8
Single Cut Wedges or Kickers	9
High Tension Steel Bands	10
Non-Metallic Strapping	11
Synthetic Webbing	12-14
Winches and Similar Components	15
Chains	16-17
Approved Shackle/Nut Application	18-20
Load Binders	21-24
Wire Rope/Cable	25
Softeners or Edge Protectors	26
Stub Stakes	27
General Usage of Stakes	28
Pallets	29
Chocks	30
Button Cap Nails	31
Weld Applied Securements to Railcars	32
Intermodal Containers and Platforms	33
Twist Locks	34
Securement Methods for Individual Commodities on Platforms	29
Unitized Banding	35-37
Dimensional Lumber	38
Sheet Rock	39
Styrofoam Loads	40-42
Structural Steel	43-44
Heavy Equipment	45
Dozer on Platform	46
Corrugated Steel Pipe	47
Steel Pipe	48
Plastic Pipe	49
Large Corrugated Plastic Pipe	50
Floating Pipe Loads	51-52

Rubber Tire Vehicles	53
Semi-Trailers	54
Cribbing for Semi Trailer on Platform	55
Empty Trailer Flats	56
Small Boats	57
Miscellaneous Small Equipment	58
Empty Platforms on Flat Car	59
Rail Loads on Flat Cars in a Revenue Train	60-61
Railroad Ties on Flat Cars in a Revenue Train	62-63
Canvas Sided Trailers	64-65
Chain Equipped Flat Cars	66-67
Trailers with Drop Axles	68
Blocking Axles	69-72
Gondola Scrap Loads Bound for Out of State	73
Plate C	74
How to Load a Railcar, Trailer or Platform for the Alaska Railroad	75-81
Glossary	82-85
Approved Polyester Strapping	86-93

ARRC General Tie Down Rules

- Safety to the public, customer, shipment and ARRC is the most important subject to be considered in the application of these rules. When in doubt as to their interpretation, users must apply to an ARRC Car Department Supervisor to ensure the safest course is followed.
- ARRC Carmen may request additional securement at any time.
- All bearing pieces and separators must not be higher than wide and must be free from defects.
- All decks will be free from ice and snow before loading.
- All loose or unsecured items such as container locks, straps or unused bearing pieces and separators will be removed or stowed prior to loading, securing and/or departure.
- Placement of loads will not interfere with applicable safety appliance regulations.
- All loads will be placed to the center of the car.
- All containers and platforms secured with twist locks must be down flat on all four corners with locks fully engaged.
- Containers not secured with twist locks must be protected by the use of stub / pocket stakes and strapped securely to rail car.
- Stub stakes will be located not more than four (4) feet nor less than three (3) feet from each end of container or platform and must be fully seated in stake pocket.
- Twenty foot containers require at least two straps if not secured with twist locks.
- Forty foot containers require at least 2 straps or more straps dependent upon the weight of the load if not secured with twist locks.

- Polyester webbing used for securement of cargo on cars, trailers and platforms must have a minimum design (safety) factor of 3:1 between the working load limit and the maximum breaking strength.
- *The securement standard for all loads when using chains shall be at the AAR minimum breaking strength standard of 6:1. Example: the weight of material x 6 ÷ MBS of chain = amount of chains used. (100,000# x 6 = 600,000# ÷ 26,400 *3/8" chain* = 23 chains) There is a ledger located on page 16 that has a breakdown of the MBS for various sized chains.*
- Chains shall be crossed when possible and angled 45 degrees from the deck, pulling in both directions of the load.
- Chains running through stake pockets must pull on the same side of the stake pocket as the load.
- Chains and binders must be arranged with the hook back to the chain and the binders wired to prevent loosening. Turnbuckle style binders must also be wired.
- Hooks must be re-hooked to the chain above the deck surface.
- Make sure vehicles are spotted on the car deck to create a 45-degree angle with tie down chains.
- All multiple pieces of blocking or bearing pieces and separators stacked in layers must be firmly nailed to each other. Bearing pieces on wooden decks must be nailed to the deck. Bearing pieces on steel decks must be secured back to the load if possible, or cross braced to prevent displacement.
- Separators should be at least 8 inches inboard on each end of the load and spaced equally along its length. Spacing should be not greater than 8 feet apart. Multiple layers of separators should be arranged in a vertical manner.
- All products must be properly secured, and in accordance to the specifications found in this manual.

- Bundles shall be banded together before being stacked.
- Loads of multiple bundles must be unitized.
- Loads shall be arranged with the larger pieces on the bottom and the smaller ones on top.
- Bands and straps must be free of defects and have softeners/edge protectors applied where passing over sharp objects or when clamping force will cause damage to the product.
- Loads equipped with pneumatic tires must have wooden wheel chocks secured against the leading and trailing edges of tires. Wheel chocks are to be applied in front of the front tires and on the leading and trailing ends of the rear axle(s). Wheel chocks must be applied tight against the tire(s).
When securing loads to Chain Equipped Flat Cars, wheel chocks are not required.
- Loads of pipe or similar products without side stakes must have pipe chocks nailed to the ends of all separators and separators shall be arranged in a vertical manner.

Securement Items

Blocking



- Blocks should preferably be made of hardwood such as Ash, Birch, Cypress, Elm, Maple or Oak.
- Blocks must be free of defects such as large knots and splits.
- Blocking must always be wider than it is high
- Blocking less than 5 inches tall must be solid
- Blocking greater than 5 inches tall may be constructed by securely nailing multiple pieces together
- Blocks must be secured to deck with at least 4 nails widely spaced to resist twisting. Nails must be large enough to penetrate 1 ½ inches into the deck. Additional nails must be applied less than ten inches apart for the full length of the piece.
- Nails must be at least 1 ½ inches longer than the thickness of the piece being added.

Double Cut Wedge Blocks



- Double cut wedge blocks are typically used as wheel chocks on vehicles and also for locating and securing large diameter pipe.
- Blocks should preferably be made of hardwood such as Ash, Birch, Cypress, Elm, Maple or Oak.
- Blocks should be free of defects such as large knots and splits.
- Blocks must be secured to the deck with at least 4 nails widely spaced to resist twisting. Nails must be large enough to penetrate 1 ½ inches into the deck.

Single Cut Wedges or Kickers



- Blocks should preferably be made of hardwood such as Ash, Birch, Cypress, Elm, Maple or Oak.
- Blocks should be free of defects such as large knots and splits.
- Blocks must be secured to wooden deck with at least 4 nails widely spaced to resist twisting. Nails must be large enough to penetrate 1 ½ inches into the deck.
- Wedges used for end blocking must have the long side against the deck.

High Tension Steel Bands

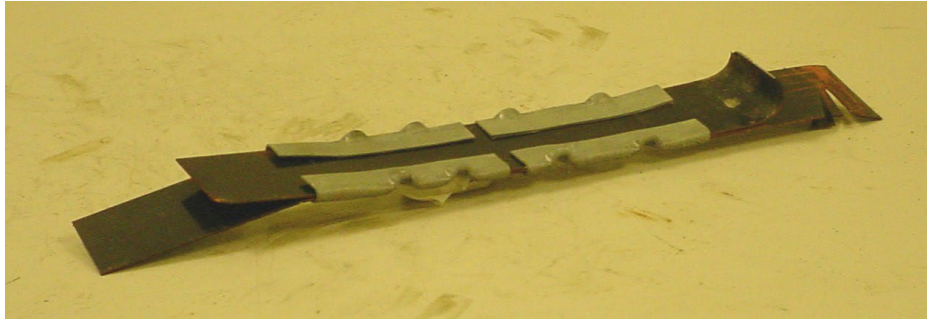

- All banding used in securement of open top loads must be AAR approved.
- The use of second hand or reclaimed bands is prohibited.
- A high tension band that has been previously used, cut, or broken is considered second hand.
- Splicing of new banding is prohibited.
- High tension bands encircling a pile must be machine tensioned and sealed toward the top of the load, in a location visible from the ground, when possible.
- High tension bands attached to the side pockets or loops must be sealed no closer than 18 inches from loops or pockets.
- Free ends of bands must extend at least 2 inches from the seal, but not more than 12 inches.
- Tie down loops must be at least 3/8 inch in diameter and free of sharp edges.
- Metal band protectors are to be used at stake pockets and where bands contact sharp edges on equipment or lading.
- Metal protectors are required on sheet or plate steel. Composition material, treated hardboard, or hardcore paper protectors are acceptable in other areas.
- Protectors must be applied to prevent movement.
- Two seals per band is **required as banding permits**, and required when shipping pipe.
- Each seal clip must be crimped twice.

Nonmetallic Strapping



All approved nonmetallic strapping will be assigned an AAR identification number or mark and applied in a manner, which makes the markings readily visible to the load inspector.

****All polyester strapping information is located in the back of this manual.****

Synthetic Webbing



- Nylon webbing is not approved for securement in open top loading. Woven polyester webbing is the only approved webbing to be used.
- Woven polyester webbing must have a design safety factor of 3:1.
- Working load limit shall be used to calculate number of straps required to ensure safety factor is maintained.
- Webbing must be applied without tears, holes, cuts, twists or kinks which degrade its working strength.

FIGURES - DAMAGED WEB TIE DOWNS

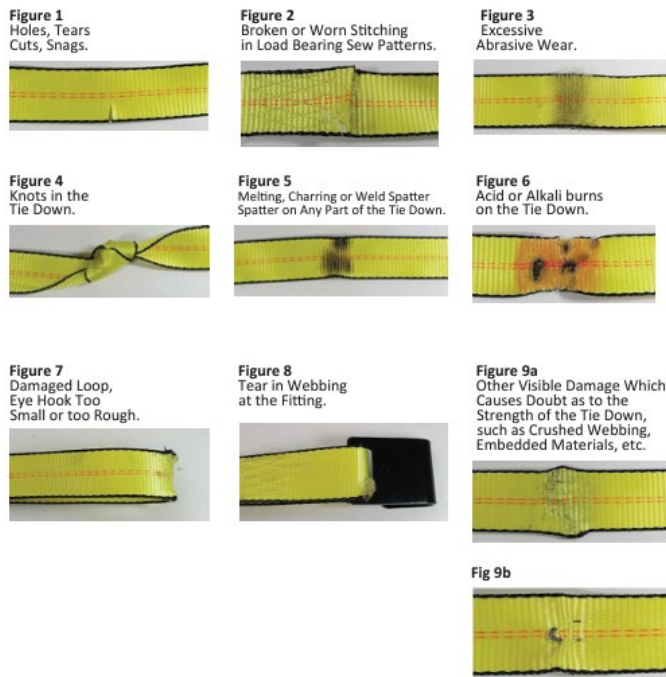

©2020 WEB SLING & TIE DOWN ASSOCIATION, INC.

Fig. 20.9 Sample web defects

- Webbing must be applied within 5 degrees of perpendicular.

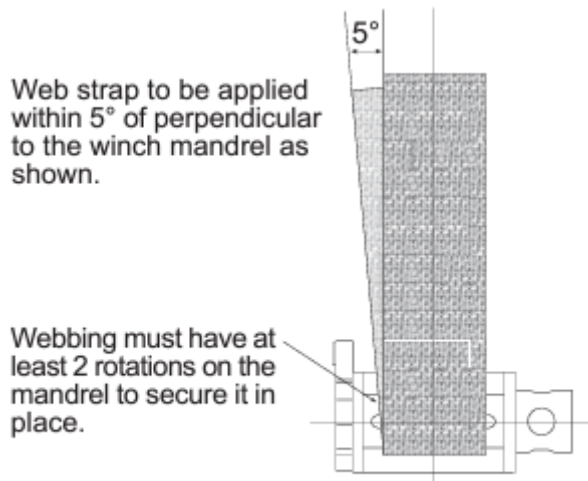

Fig. 20.6 Proper strap application

- Softeners must protect the webbing from any sharp points or edges.

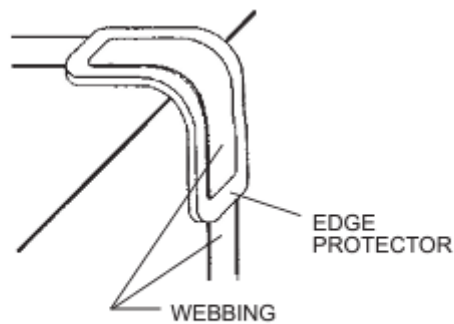

Fig. 20.4 Typical slide-on edge protector

- Hooks on the straps must be arranged in a hanging fashion so that if the strap loosens, it will still remain connected to the rub rail of the trailer. If this can't be done the hooks will need to be wired to the trailer, platform or car.



****All WLL (working load limits information is located in the back of this manual.****

Winches and Similar Components

- Winches, ratchets, hook eyes, connecting chain etc. must equal or exceed minimum breaking strength of webbing being used.
- A winch bar such as the one illustrated below shall be used. Cheater bars are prohibited.

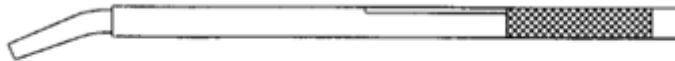

Fig. 20.1 Winch bar

- Winches should be in good working order with no sharp edges or defects that may harm the webbing.



Fig. 20.2 Fixed winch styles

- Portable web assemblies with ratchet buckle and end hooks are also acceptable on the ARRC.

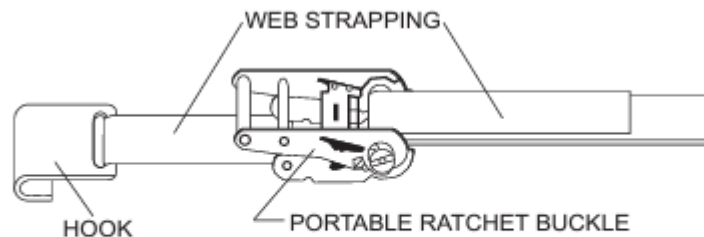

Fig. 20.3 Portable web ratchet assembly

Chains



- Chains must be free of cracks, bent or twisted links, gouges or pits, knots, or portions subjected to high temperature.
- Chains must always be hooked back to the chain.
- Chain assemblies provided by a chain manufacturer with the hooks joined by a flash or butt-welded connecting link and carrying the manufacturer's permanent and distinctive mark identifying the grade of the link are acceptable.
- Chain dimensions, and **minimum breaking strengths** are shown in the table below.

Table 21.5 Summary of chain grade, size, and MBS

Grade 30		Grade 43		Grade 70		Grade 80		Special Alloy	
Size (in.)	MBS (lb)	Size (in.)	MBS (lb)	Size (in.)	MBS (lb)	Size (in.)	MBS (lb)	Size (in.)	MBS (lb)
1/8	1,600	1/4	7,800	1/4	12,600	7/32	8,400	3/8	36,000
3/16	3,200	5/16	11,700	5/16	18,800	9/32	14,000	1/2	55,000
1/4	5,200	3/8	16,200	3/8	26,400	5/16	18,000		
5/16	7,600	7/16	21,600	7/16	35,000	3/8	28,400		
3/8	10,600	1/2	27,600	1/2	45,200	1/2	48,000		
7/16	14,800	5/8	39,000	5/8	63,200	5/8	72,400		
1/2	18,000	3/4	60,600			3/4	113,200		
5/8	27,600	7/8	73,500			7/8	136,800		
3/4	42,400					1	190,800		
7/8	51,200					1 1/4	289,200		
1	71,600								

8.0 IDENTIFICATION

8.1 Grade 30, 43, and 70 Chain

Grade 43, 70, and 5/16" (8.4 mm) and larger Grade 30 chains shall have periodic embossing for identification purposes. The embossing shall include the manufacturer's identification mark or symbol and the grade indicator as shown in 8.1.2 through 8.1.4.

8.1.1 5/16" (8.7 mm) and 3/8" (10 mm) Grade 43 and 70 chain shall be embossed at intervals no greater than 1 ft. (0.3 m). All other Grade 30, 43, and 70 chains shall be embossed at intervals no greater than 3 ft. (0.9 m).

8.1.2 5/16" (8.4 mm) and larger Grade 30 chains shall be embossed at least with 3, 30, or 300.

8.1.3 Grade 43 chains shall be embossed at least with 4, 43, or 430.

8.1.4 Grade 70 chains shall be embossed at least with 7, 70, or 700.

8.1.5 1/4" (7 mm) and smaller Grade 30 chains may be embossed at the option of the manufacturer.

8.2 Grade 80 and 100 Chain

Grade 80 and 100 chains shall have periodic embossing for identification purposes. The embossing shall include the manufacturer's identification mark or symbol, the traceability code or date code, and the grade indicator as specified in 8.2.2 and 8.3.3.

8.2.1 Grade 80 and 100 chains shall be embossed at intervals no greater than 3 ft. (0.9 m).

8.2.2 Grade 80 chain shall be embossed at least with 8, 80, or 800.

8.2.3 Grade 100 chain shall be embossed at least with 10, 100, or 1000.

8.3 Machine, Coil, Passing Link, and Stainless Chain

Machine, Coil, and Passing Link, and Stainless chains may be embossed at the option of the manufacturer.

8.4 Embossment Requirement

All chain identification markings shall be embossed using raised characters. Chain links shall not be marked with indented characters.

Approved Shackle/Nut Application



Proper Application of Jam Nut



Application of Steel Type Lock Nut



Application of Nylock Type Nut



Application of Wire



Shackle bolts must be wired as shown.

SHACKLES



ROUND PIN
Do not side load, do not use as a collector ring, always use cotter pin.



SCREW PIN
Use when picking and placing a load, tighten pin prior to each lift.



BOLT-TYPE
Use in permanent or long-term installations always use nut and cotter.

SCREW PIN SHACKLE PIN SECURITY

MOUSE SCREW PIN WHEN USED IN LONG TERM OR HIGH VIBRATION APPLICATIONS

A secondary securement method used to secure screw pin from rotation or loosening. Annealed iron wire is looped through the hole in collar of pin and around the adjacent leg of the shackle body with wire ends securely twisted together. Multiple wraps are required for securement where the load may slide on the shackle pin.



ANGLE LOADS MUST BE APPLIED IN THE PLANE OF THE BOW FOR 3/16" to 3" SHACKLE.

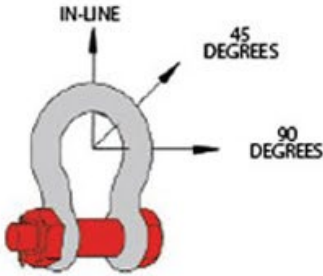

TABLE 1

**Side Loading Reduction Chart
For Screw Pin and Bolt-Type Shackles Only ****

Angle of Side Load from Vertical In-Line of Shackle	Adjusted Work Load Limit
0° In-Line*	100% of Work Load Limit
45° from In-Line*	70% of Work Load Limit
90° from In-Line*	50% of Work Load Limit

* In-Line load is applied perpendicular to pin.
** DO NOT SIDE LOAD ROUND PIN SHACKLES.

Never Exceed 120° included angle. Use Bolt-Type and Screw Pin Shackles ONLY.

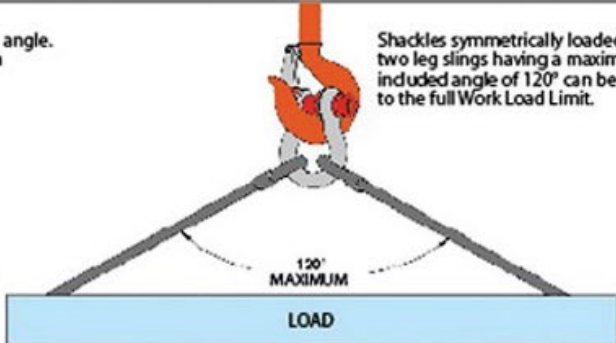

Shackles symmetrically loaded with two leg slings having a maximum included angle of 120° can be utilized to the full Work Load Limit.

In weather above 40-degrees duct tape and zip ties are also allowed.

Load Binders

- Binders must be marked with the rated capacity equal to their minimum breaking strength.
- **The minimum breaking strength of the chain being used must be equal to or more than the breaking strength of the binder.**
- Binder must be equipped with two grab hooks.
- Grab hooks should be compatible with the size of chain being used.
- Welding of binders to chain is prohibited.

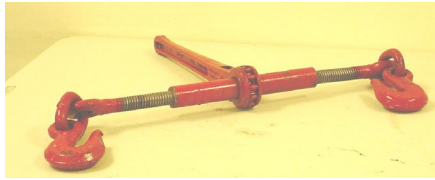

Ratchet Type



Lever Type

- Binders of the lever type must be wired to prevent loosening in transit.

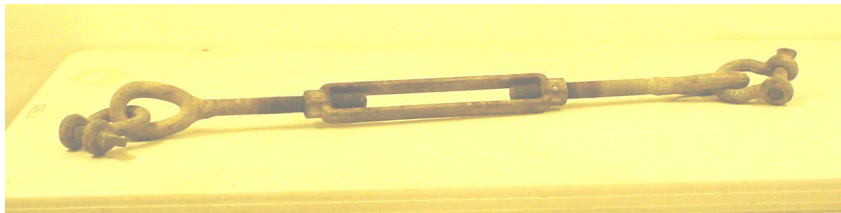

Turnbuckle Type

- Turnbuckle binders must be secured to prevent loosening during transit by using jam nuts on the shafts or using wire when there is a hole in the shaft for that purpose.
- Softeners **must** be used where chains may damage load or where load may damage chain.
- Minimum Breaking Strengths are shown below.

RATCHET CHAIN BINDER SPECIFICATIONS

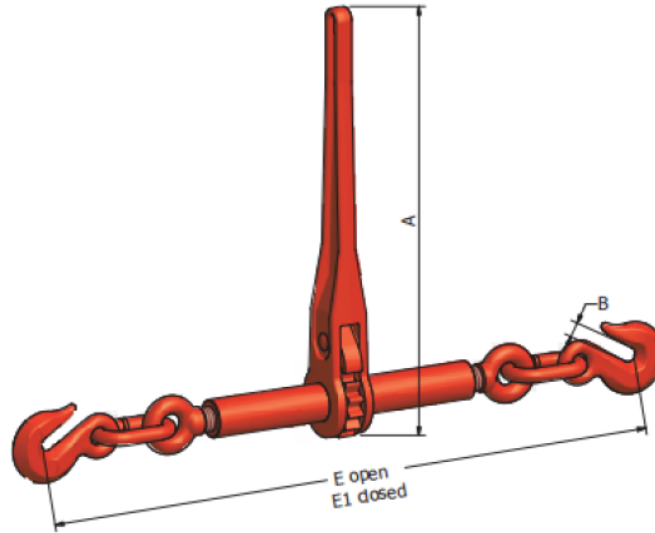

Applied norm WSTDA T6

PART NUMBER	SIZE	WLL (LBS)	MBL (LBS)	WEIGHT (LBS)	DIMENSIONS			
					A	B	E	E1
CB135	1/4" - G7	3,150	11,000	3.71	8.89	0.39	16.34	20.27
CB150	5/16" - G7 3/8" - G4	5,400	19,000	10	15.24	0.5	22.64	28.94
CB155	3/8" - G7 1/2" - G4	9,200	33,000	11.7	15.24	0.65	23.45	29.92
CB165	1/2" - G7 5/8" - G4	13,000	46,000	15.5	15.24	0.73	27.16	33.07

ULTIMATE LOAD IS 3.5 TIMES THE WORKING LOAD LIMIT

LEVER CHAIN BINDER SPECIFICATIONS

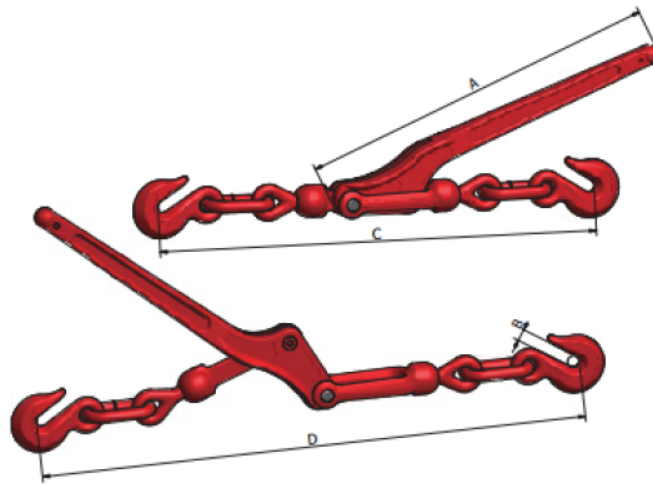

Applied norm WSTDA T6

PART NUMBER	SIZE	WLL (LBS)	MBL (LBS)	WEIGHT (LBS)	DIMENSIONS			
					A	B	C	D
CB135	1/4" - G7	3,150	11,000	3.78	11.88	0.39	14.56	17.32
CB140	5/16" - G7 3/8" - G4	5,400	19,000	7.68	15.74	0.5	19.48	23.89
CB145	3/8" - G7 1/2" - G4	9,200	33,000	12.36	17.12	0.65	22.04	29.96
CB160	1/2" - G7 5/8" - G4	13,200	46,000	19	20.39	0.73	26.02	31.10

ULTIMATE LOAD IS 3.5 TIMES THE WORKING LOAD LIMIT

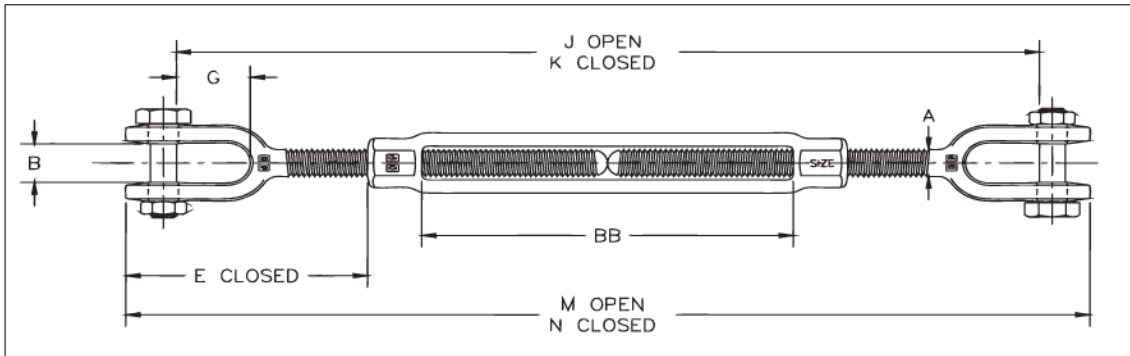

HG-228 Jaw & Jaw

Thread Dia. & Take Up (in.)	HG-228 Stock No.	Working Load Limit (lbs)*	Weight Each (lbs.)	Dimensions (in)									
				A	B	E Closed	G	J Open	K Closed	M Open	N Closed	BB	
† 1/4 x 4	1032493	500	.37	.25	.45	1.66	.64	11.19	7.19	12.18	8.18	4.07	
† 5/16 x 4-1/2	1032518	800	.56	.31	.50	2.02	.87	13.07	8.57	14.12	9.62	4.58	
† 3/8 x 6	1032536	1200	.85	.38	.53	2.11	.85	16.25	10.25	17.50	11.50	6.10	
1/2 x 6	1032554	2200	1.82	.50	.64	3.22	1.07	18.65	12.65	20.14	14.14	6.03	
1/2 x 9	1032572	2200	2.29	.50	.64	3.20	1.07	24.94	15.94	26.43	17.43	9.96	
1/2 x 12	1032590	2200	2.71	.50	.64	3.20	1.07	30.94	18.94	32.43	20.43	12.36	
5/8 x 6	1032616	3500	3.21	.63	.79	3.90	1.32	19.74	13.74	21.82	15.82	6.03	
5/8 x 9	1032634	3500	3.95	.63	.79	3.89	1.32	26.08	17.08	28.16	19.16	9.99	
5/8 x 12	1032652	3500	4.58	.63	.79	3.89	1.32	32.08	20.08	34.16	22.16	12.99	
3/4 x 6	1032670	5200	4.80	.75	.97	4.71	1.52	21.09	15.09	23.68	17.68	6.13	
3/4 x 9	1032698	5200	5.85	.75	.97	4.68	1.52	27.49	18.49	30.08	21.08	9.59	
3/4 x 12	1032714	5200	6.72	.75	.97	4.68	1.52	33.49	21.49	36.08	24.08	12.59	
3/4 x 18	1032732	5200	8.45	.75	.97	4.71	1.52	45.49	27.49	48.08	30.08	18.53	
7/8 x 12	1032750	7200	9.37	.88	1.16	5.50	1.77	34.65	22.65	37.62	25.62	12.16	
7/8 x 18	1032778	7200	11.8	.88	1.16	5.50	1.77	47.12	29.12	50.09	32.09	18.63	
1 x 6	1032796	10000	10.4	1.00	1.34	6.09	2.05	23.82	17.82	27.18	21.18	6.18	
1 x 12	1032812	10000	13.8	1.00	1.34	6.09	2.05	35.82	23.82	39.18	27.18	12.18	
1 x 18	1032830	10000	17.1	1.00	1.34	6.09	2.05	47.82	29.82	51.18	33.18	18.18	
1 x 24	1032858	10000	21.0	1.00	1.34	6.06	2.05	60.42	36.42	63.78	39.78	24.84	
1-1/4 x 12	1032876	15200	21.9	1.25	1.84	8.09	2.82	39.37	27.37	43.58	31.58	12.06	
1-1/4 x 18	1032894	15200	25.9	1.25	1.84	8.09	2.82	51.37	33.37	55.58	37.58	18.06	
1-1/4 x 24	1032910	15200	29.8	1.25	1.84	8.09	2.82	63.93	39.93	68.14	44.14	24.62	
1-1/2 x 12	1032938	21400	32.6	1.50	2.06	8.93	2.81	40.76	28.76	45.68	33.68	12.32	
1-1/2 x 18	1032956	21400	38.0	1.50	2.06	8.93	2.81	52.76	34.76	57.68	39.68	18.32	
1-1/2 x 24	1032974	21400	43.5	1.50	2.06	8.93	2.81	65.38	41.38	70.30	46.30	24.94	
1-3/4 x 18	1033018	28000	53.5	1.75	2.60	9.36	3.35	53.35	35.35	59.16	41.16	18.37	
1-3/4 x 24	1033036	28000	61.1	1.75	2.60	9.36	3.35	65.35	41.35	71.16	47.16	24.37	
2 x 24	1033054	37000	96.3	2.00	2.62	11.80	3.74	69.64	45.64	76.72	52.72	24.48	
2-1/2 x 24	1033072	60000	167	2.50	3.06	13.26	4.44	72.97	48.97	82.18	58.18	24.60	
2-3/4 x 24	1033090	75000	199	2.75	3.69	14.92	4.19	74.75	50.75	85.50	61.50	24.65	

*Proof Load is 2.5 times the Working Load Limit. Ultimate Load is 5 times the Working Load Limit. † Mechanical Galvanized

Wire Rope/Cable

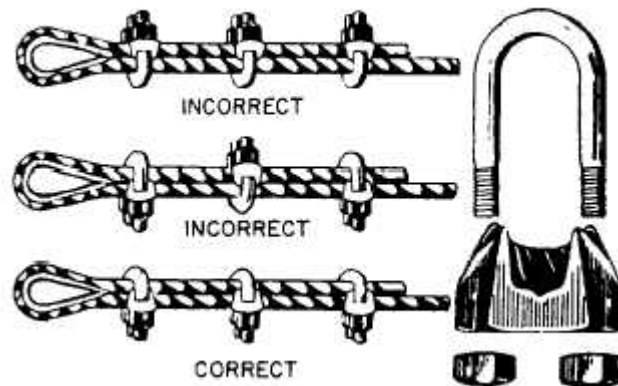

- Where wire rope/cable is used, the ends must be overlapped a minimum of 12 inches
- The minimum number of clips is as follows

3/8 inch cable	2 clips spaced 2 ¼ inches apart
½ inch cable	3 clips spaced 3 inches apart
5/8 inch cable	3 clips spaced 3 ¾ inches apart
¾ inch cable	4 clips spaced 4 ½ inches apart
7/8 inch cable	4 clips spaced 5 ¼ inches apart
1 inch cable	4 clips spaced 6 inches apart
- Cable clips must be applied with the saddle in contact with the running end of the rope.
- Wire rope/cable must be protected at all sharp corners and edges.
- Wire rope/cables shall be positioned to touch each other.
- Used rubber hose, carpet, and hardcore paper work well as softeners to protect cable at sharp edges.

Softeners or Edge Protectors

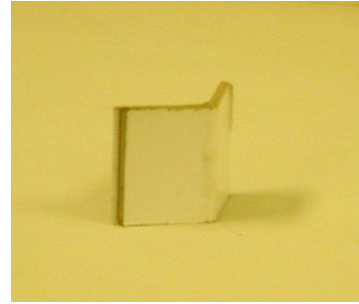

- Softeners can be made of used rubber hose, cardboard, old defective straps or carpet. Cardboard softeners must be of the treated type to avoid decomposition due to moisture. These softeners are often referred to as hardcore paper.
- Softeners are to be placed between high tension steel bands, nonmetallic bands, synthetic web straps, wire rope/cable, chains and binders, other types of securement, and sharp edges or points to protect the load and securement pieces from damage.
- Softeners must also be placed between wire rope/cables where they intersect to avoid chaffing.
- Softeners should be secured in such a fashion to avoid displacement, should the load shift during transit.

Stub Stakes



- Loads not secured in twist locks must be protected from lateral movement by the use of pocket or stub stakes.
- Pocket or stub stakes are to be made of metal and must be fully seated in the stake pocket.
- Pocket or stub stakes are to be used when loading both platforms and containers on flat cars.
- Stakes are to be located not more than 4 feet nor less than 3 feet from the end of the container or platform.
- A sufficient number of pocket stakes must be applied to captured containers to prevent their movement off the side or end of the car should the load shift in any direction.

General Usage of Stakes



Loads not secured with twist locks must be protected from lateral movement by applying stub stakes. Load must then be securely strapped to the rail car.

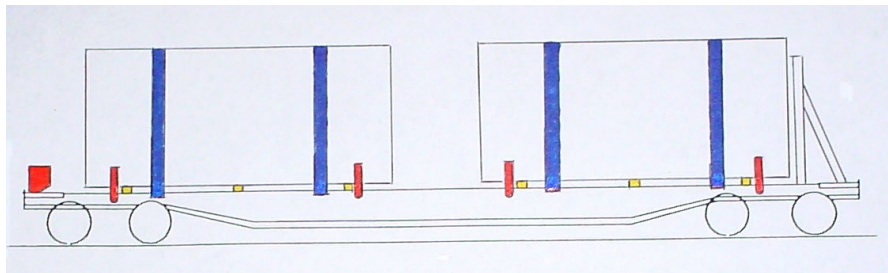

Loads should have four stakes each and non-bulkhead end of car must have two stakes applied.

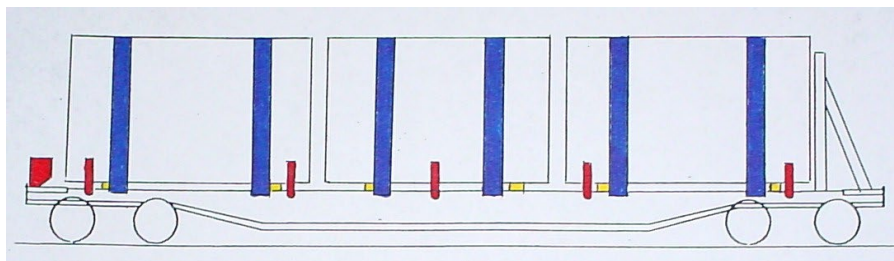

“Captured” center loads require two stakes located at center of bundle.

Pallets

The ARRC will allow palletized loads. Pallets must be in good condition and can only be single stacked on the trailer, platform or car. The loads must be securely wrapped in plastic wrap and be secured to the trailer, platform or car deck. Pallets used as seperaters are still prohibited.



When super sacks are loaded on trailers, pallets must be butted up together. At a minimum, the ends must have two straps placed over sacks, and placed to eliminate straps from slipping off. Inboard sacks are required to have at least one strap over the sacks but may require more at times. This goes for trailers, railcar decks and platforms. *Double stacked palletized loads are prohibited.*



Chocks



The ARRC will allow plastic chocks for Trailer On Flat Car (TOFC) loads. This change does not pertain to railcar loads. Wood chocks are the only accepted chocks on railcar loads.

- Chocks must be completely on the bearing pieces and separators and tight against load.
- Chocks must be nailed down with supplier's nails, **or 3** each, 12d X 3 1/8 inch.
- Chocks must not be broken or cracked.
- **Chocks are to be installed on each bearing piece.**
- **Chocks are to be installed the top and bottom of each separator.**
No bearing pieces or separators should be missing chocks.
- On railcar loads, wooden chocks shall be made of hardwood and be free from all defects. Wooden chocks **must be adequately sized to prevent the load from rolling and have the square** end firmly against the pipe load.
- Wood chocks must be nailed to separators using 20D nails with a minimum of four each. Quantity of nails will be dictated by loading figure used in the AAR Open Top Loading Rules. If power driven nails are used the quantity must be doubled. Again, quantity is based on figure used in AAR Open Top Loading Rules. When applying nails to hard wood, holes must be pre-drilled to prevent the wood from splitting.

Button Cap Nails



Button cap nails are commonly used in the construction trade to secure Styrofoam insulation to roof decking prior to putting down the tar paper and hot moping. They are also used to hold vapor barrier to wall panels before the siding is applied. These nails come with metal as well as plastic caps with the metal type being made for heavier duty applications.

- Button cap nails are strongly recommended for use as additional securement on tarps/covers where wind exposure could cause a failure.

Weld Applied Securements to Railcars

Welding lading directly to railcars is prohibited. The welding of rods, angle iron, flat bars and straps directly to both the load and railcar for the securement of the load is prohibited unless prior approval is given by proper AKRR personnel.



Intermodal Containers and Platforms



The three most common types of conveyances used in intermodal freight on the Alaska Railroad are

1. Platforms
2. Post Platforms
3. Containers

All containers and platforms must conform to current industry standards.

This includes:

- Acceptable container lengths are 20, 24, 28, 40, 45, 48, and 53 feet.
- Acceptable platform lengths are 20, 24, 28, 40, and 53 feet.
- All containers and platforms must be in reasonably good condition.
- Door closure and locking devices must be fully operational with **the manufactured** seals applied when loaded.
- Corner castings and locking pockets must be free of debris and corrosion.
- Containers and platforms must be clearly marked with appropriate identification.
- Platforms with collapsible posts must have posts securely locked in place.

Twist Locks



Semi-Automatic Type



Manual Locking Type

- Twist locks are the preferred method of securing platforms or containers to the rail car.
- Twist locks must be free from defects such as cracks, chips, or excessive corrosion.
- Twist locks must operate in the intended method as described by the manufacturer.
- Operating handles, cables, and fixtures should move freely and detents must function as designed.

Securement Methods for Individual Commodities on Platforms

Unitized Banding

- Multiple layer loads require unitized banding
- Individual pieces of a load or separate bundles of material must be stacked with separators arranged in a vertical pattern, **and shall not be higher than wide.**
- A minimum of two unitizing bands must be applied to each bundle
- Banding must be arranged to secure the bottom layer of the load to the second layer, the second layer to the third and so on until entire load is one “unit”.

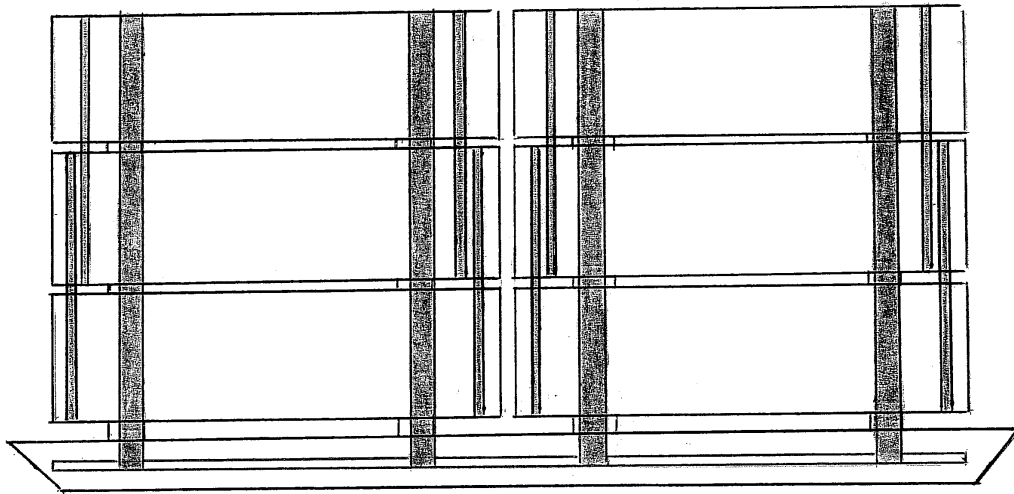

- Unitized bundles must then have a minimum of two securement bands applied to each unit deck to deck.

- Straps may be used to subsidize loose banding, or inadequate unitizing bands.





Dimensional Lumber



- Dimensional lumber must be banded in a unitized fashion with the bottom layer gut wrapped to the second layer of bundles, which is gut wrapped to the third layer and so on.
- Two bands per bundle are mandatory.
- Four bands must connect the unitized load to the platform deck to deck.

Sheet Rock



- Product must be fully supported without overhang
- Product must be covered
- Covers must be firmly secured in a manner that will resist dislodgement under extreme wind conditions.
- Side corner protectors are preferred, and when applied, must have 2 bands each. All bands must be crimped twice
- Each stack must have at least 2 bands to the platform with appropriate softeners to prevent damage to product.
- Bundles set back from the ends of the platforms must be gut wrapped longitudinally at least twice with all **applicable** softeners applied.
- Sheetrock used as bearing pieces is allowed; however, it must be wider than it is high and in good condition.

Styrofoam Loads



- Product must be fully supported with no overhang.
- Load must be shrink-wrapped.
- Product must have at least two bands per stack, with **applicable** softeners, connected to the platform.
- Top side softeners should link adjoining stacks.
- Load must be end-banded at least twice with **applicable** softeners.
- All bands must be crimped twice.

Tarps/Protective Coverings

- Tarps or protective coverings are not required by the railroad but are often applied at shipper's request. Securement of these coverings must meet industry standards. Tarps are not to be used as load securement.



- Corner and end protectors are highly recommended, as they not only protect the product but greatly aid in the securement of the tarp.



- Loose tarps do cause problems for the railroad.



In transit, when a tarp comes loose and extends beyond the top and or side of a car, it can be picked up by the high / wide load detectors located at various points along the rail belt. These detectors are positioned near the tracks to identify loads that have shifted out of position and when activated, the train is required to stop and the crew must inspect their train to discover the problem. In Alaska, this can become a two or three mile walk in sub-zero

darkness to look at a flapping tarp. This not only causes train delays, but also exposes the trainman to unnecessary risks.

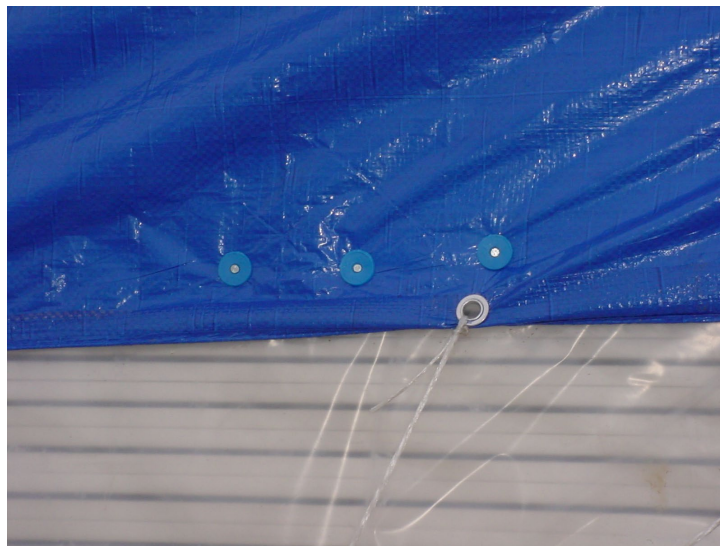

- Button cap nails are strongly recommended for use as additional securement on tarps/covers where wind exposure could cause a failure.

Structural Steel

Structural steel is an inherently problematic type of load.



Different shapes, sizes, along with the desire to keep a multiple piece “building kit” together on a single trailer or platform can create many challenges.

- Multiple pieces of blocking or separators stacked in layers must be firmly nailed to each other.
- Bearing pieces on wooden decks must be nailed to the deck. Bearing pieces on steel decks must be secured back to the load if possible, or cross braced to prevent movement.
- Blocking shall be of sufficient size and placed to easily support the load.
- Separators shall be located at least 8 inches inboard on each end of the load and spaced equally along its length.
- Separators shall not be spaced greater than 8 feet apart.
- Separators shall span the entire width of the load when possible.
- Multiple layers of separators shall be arranged in a vertical manner.
- Braces shall be affixed to each end of separators against load to prevent migration laterally.
- All products must be secured.
- Bundles shall be package wrapped before being stacked.
- Multiple layer loads must be secured in a unitized manner.
- Chains and binders must be arranged with the hook back to the chain with the binders secured to prevent loosening.
- Softeners must be applied where sharp edges might cause damage to bands or straps.



- **Cribbing applied to support through a void can be higher than it is wide, but it must be braced or tied back to the load to keep it from rolling or migrating.**

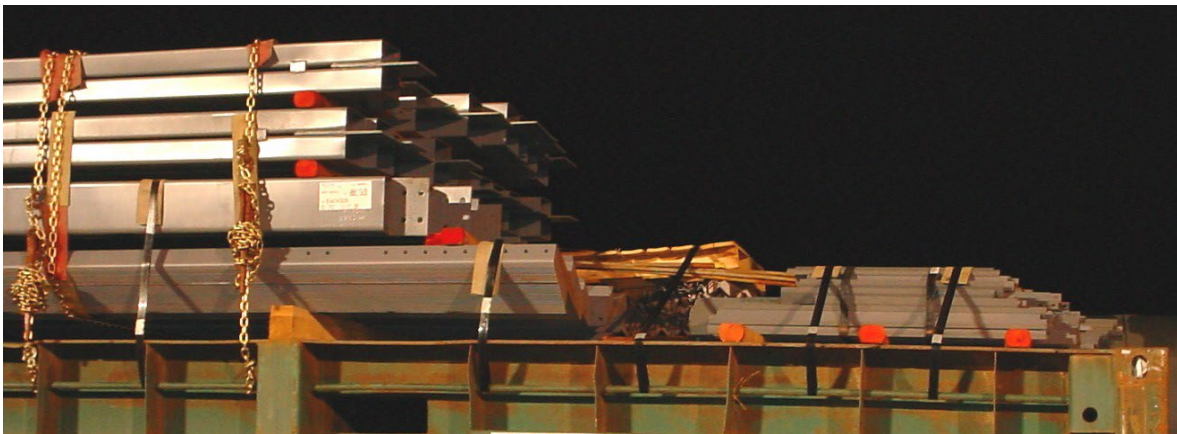

- **All products must be secured. Loose objects on top of I-Beam or tucked inside of square tubing is **prohibited**.**

Heavy Equipment

- Chains must be applied as close to 45-degrees from the platform as possible.
- Chains must be hooked back to the chain, and binders must be wired.
- Loads must be secured to a minimum of **6:1 MBS** of the loads own weight.
- Chains should be crossed when possible and angled 45-degrees from the deck, pulling in both directions on load.
- Blocking must be nailed to wooden decks, or otherwise secured to prevent migration.
- Buckets and booms must be cross chained to prevent swinging. The bucket should be lowered to the deck when possible. The boom needs to be trailing.



- Articulation point lock must be engaged.



- Outriggers must be secured with locking pins or chained to prevent movement.

Dozer on Platform



- Chains and binders must be applied to solid points on the chassis of the machine.
- Loads must be secured to a minimum of **6:1 MBS** of the loads own weight.
- Chains should be crossed when possible and angled 45-degrees from the deck, pulling in both directions on load.
- Loads should be cross chained when possible. If this can't be achieved, blocking must be applied along the inside of the track assemblies, then interconnected, and secured to the deck of the platform to prevent load from shifting laterally.
- Vertical hydraulic rams on the front of the machine need to be secured to prevent them from swinging out sideways.
- **Lever style binders** must be wired.

Corrugated Steel Pipe



- Pipe shall have separators equally spaced along the length of the pipe.
- Separators shall be placed between 8 inches and 18 inches from the ends.
- Separators shall be arranged in a vertical manner and less than 8 feet apart. Separators that are rolled on ends where a pipe chock sits needs to be replaced (not used) so that the chock will sit flush on separator.
- Chocks must be positioned firmly against both sides of the load, top and bottom of each bearing piece and separator, where a chock can be positioned firmly again the pipe load.
- Intermediate separators must have braces applied to prevent them from migrating out of position.
- Load must be package wrapped and unitized.
- Sufficient securement such as a bulk head, should be added across the ends of the large pipes to keep the smaller pipes inside from shifting longitudinally.
- All banding must be tight. If any banding is found loose and cannot be repaired (such as metal banding) additional banding will be added as close to the loose banding as possible. Banding trapped between separators or bearing pieces is prohibited. Loose unitizing bands can be repaired by the addition of 2 inch polyester straps, but they must be placed in the same manner as unitizing securement, as close as possible to the loose unitized banding.

Steel Pipe



- Bundles of pipe shall be arranged with both ends as even as possible.
- Pipe shall have separators equally spaced along the length of the pipe.
- Separators shall be located at least every 8 feet and not more than 18 inches from the ends of pipe. Separators that are rolled on the ends where pipe chocks sits need to be replaced (not used) so that the wood chocks will sit flush on separator.
- Separators must be positioned to include all pipes in the load.
- Separators shall be arranged in a vertical manner and at least 8 feet apart.
- If side stakes are not installed, chocks must be positioned firmly against both sides of the load, top and bottom of each bearing piece and separator, where a chock can be positioned firmly against the pipe load.
- All banding must be tight. If any banding is found loose and cannot be repaired (such as metal banding) additional banding will be added as close to the loose banding as possible. Banding trapped between separators or bearing pieces is prohibited. Loose unitizing bands can be repaired by the addition of 2 inch polyester straps, but they must be placed in the same manner as unitizing securement, as close as possible to the loose unitized banding.
- Intermediate separators must have chocks applied to prevent them from migrating out of position.
- Load must be package wrapped and unit banded. Wood chocks must be applied to railcar loads.

Plastic Pipe



- Bundled wraps shall be arranged in a vertical manner.
- The load must be **unitized**.
- At least four bands must connect the product with the platform.
- **The load rating of the** number of bands must equal or exceed the total weight of the load.
- Chocks must be positioned firmly against both sides of the load, top and bottom **of each bearing piece and separator, where a chock can be positioned firmly again the pipe load.**
- **Bundle wrapped pipe loads require a minimum of 3 side stakes per side of car and require cord lashing on the top of the stakes to connect each other.**
- **Non-bundle wrapped plastic pipe loads require chocks and must be positioned firmly against both sides of the load, top and bottom of each bearing piece and separator, where a chock can be positioned firmly again the pipe load.**
- **If chocks are not utilized on non-bundle wrapped plastic pipe loads, it is required to have 3 side stakes per side of car and require cord lashing on the top of the stakes to connect each other.**
- **When applying side stakes on platform loads, it is preferred to use a 129xxx series flat due to platform overhang on the side stake pocket.**

Large Corrugated Plastic Pipe



- Pipe shall have separators equally spaced along the length of the pipe.
- Separators shall be located at least every 8 feet and not more than 18 inches from the ends of pipe. Separators that are rolled on ends where pipe chock sits need to be replaced (not used) so that wood chock will sit flush on separator.
- Separators shall be arranged in a vertical manner and at least 8 feet apart.
- Chocks must be positioned firmly against both sides of the load, top and bottom **of each bearing piece and separator, where a chock can be positioned firmly against the pipe load.**
- Intermediate separators must have braces applied to prevent them from migrating out of position.
- Load must be package wrapped and unitized.
- **All banding must be tight. If any banding is found loose and cannot be repaired (such as metal banding) additional banding will be added as close to the loose banding as possible.** Banding trapped between separators or bearing pieces **is prohibited.** Loose unitizing bands can be repaired by the **addition** of 2 inch polyester straps, but they must be placed **in the same manner as** unitizing securement, as close as possible to the loose **unitized banding.**

Floating Pipe Loads



- Pipe loads must be centrally located on a bulkhead flat.
- Bearing pieces must be placed 5ft in on each end and equally spaced in between. 4 bearing pieces and separators for pipe 40ft and under and 1 additional piece per 10ft over 40ft.
- Bearing pieces and separators must not be higher than wide.
- Chocks must be positioned firmly against both sides of the load, top and bottom of each bearing piece and separator, where a chock can be positioned firmly against the pipe load.
- All banding must be tight. If any banding is found loose and cannot be repaired (such as metal banding) additional banding will be added as close to the loose banding as possible. Banding trapped between separators or bearing pieces is prohibited. Loose unitizing bands can be repaired by the addition of 2 inch polyester straps, but they must be placed in the same manner as unitizing securement, as close as possible to the loose unitized banding.
- Intermediate separators must have chocks applied to prevent them from migrating out of position.
- Load must be package wrapped and unitized. Wood chocks must be applied to railcar loads.
- Side stakes must be made of hardwood with a height equal to the center of the pipe on the bottom layer but not to interfere with chocks located on bottom of separators. Locate one at

each corner of the load, outside or inside of end bearing pieces, and secure to stake pockets to prevent displacement. Load must be protected by a minimum of two pairs of stakes at all times.

- The height of the load must not exceed 11 feet above the car.

Additional descriptive pictures are below.

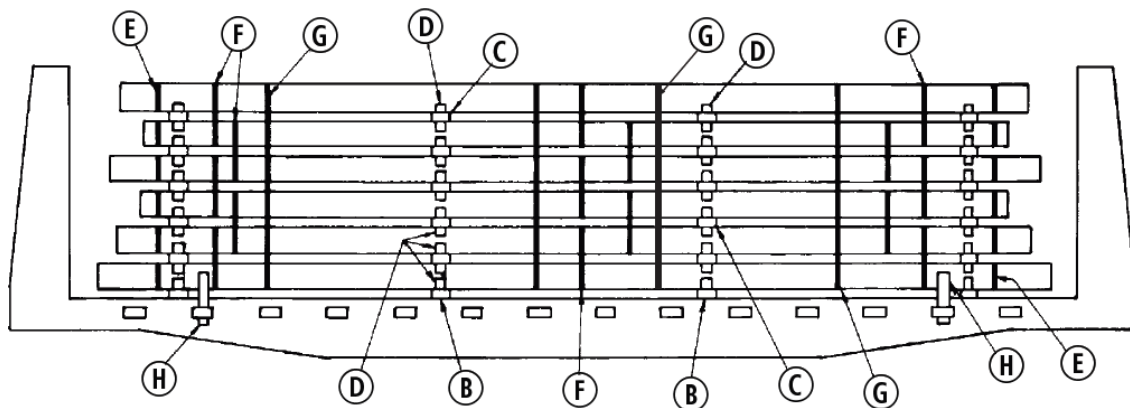
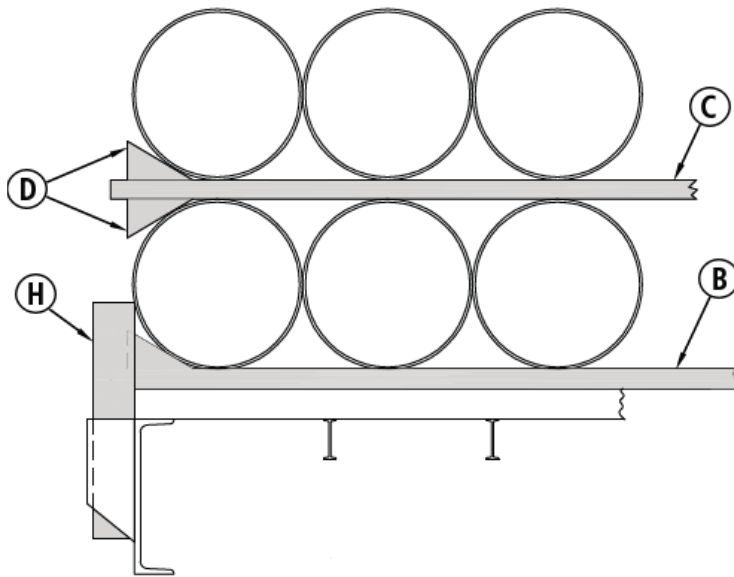

Rubber Tire Vehicles

- Loads must be secured to a minimum of **6:1 MBS** of the loads own weight.
- Chains must be connected to un-sprung chassis member areas.
- Chains shall be crossed when possible and angled 45 degrees from the deck, pulling in both directions on the load.
- **Lever style binders** must be wired.



Semi Trailer

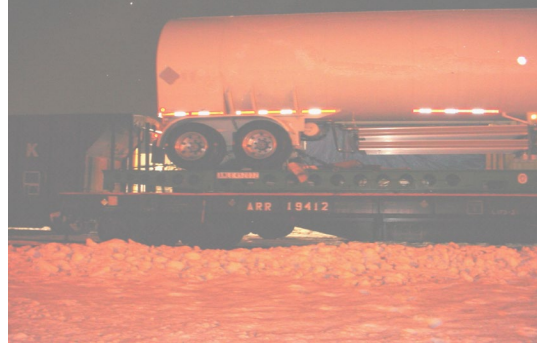

The above photos show a semi trailer on a platform. Close inspection reveals some basic problems. This trailer is secured to the platform while standing on its landing gear and the landing gear assembly was used as a point for securement. The required method for securement is illustrated below.

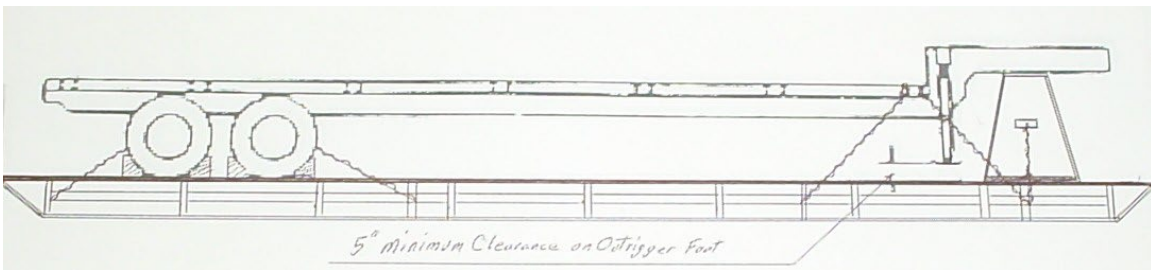

- Trailers must be secured to a minimum of **6:1 MBS** the loads own weight. Blocking under the axles is no longer required. However this does not relieve the requirement of wheel chocks for wheels where they can be nailed to the deck or platform. If the load arrives having the axles already blocked then wheel chocking is not necessary.
- The front of the trailer shall be supported with a cone or crib assembly.
- A single cross chain through the cone or crib for securement will be satisfactory.
- The nose of the trailer shall then be tied down using four chains to ensure a solid connection to the platform and the cone / crib.
- A minimum gap of 5 inches is required between the landing gear and the deck.

Cribbing for Semi Trailer on Platform

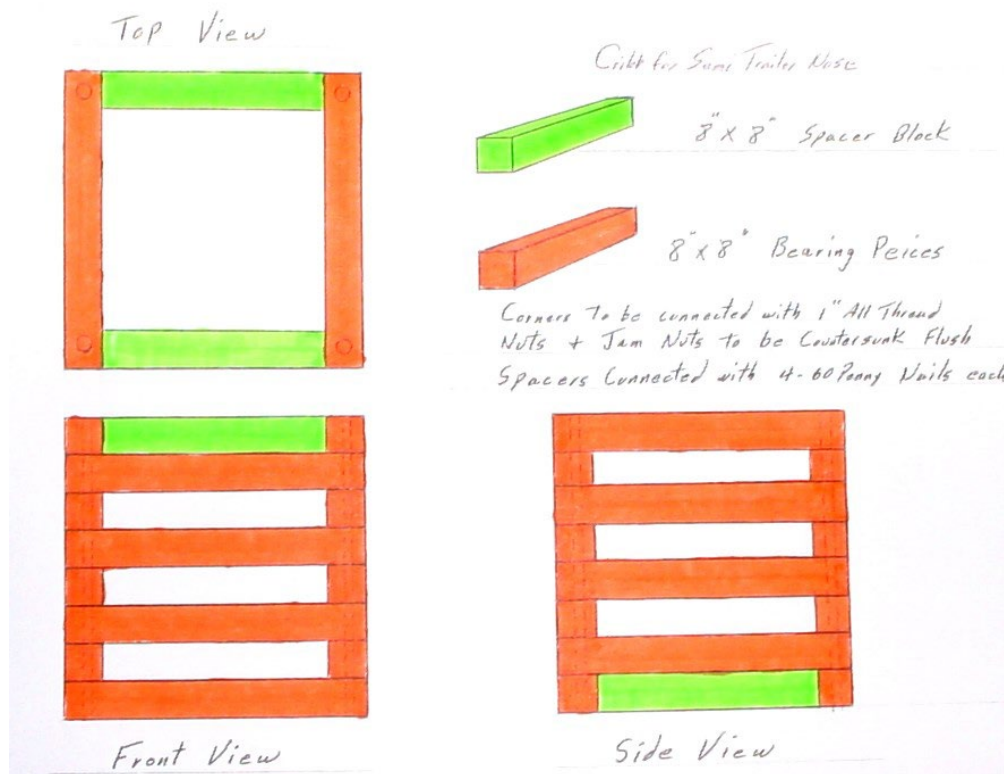

- Crib must not be higher than it is wide.
- Bearing pieces **are** to be constructed using 8x8 hardwood.
- Spacers **are** to be constructed using 8x8 hardwood.
- Bearing pieces **are** to be secured using 1 inch all thread connecting the corners.
- Flat washers with nuts and jam nuts must be counter sunk in all four corners, top and bottom.
- Spacers must be toe nailed to bearing pieces using 60 penny nails.
4 per spacer.

Empty Trailer Flats



- Empty trailer flats must not be stacked more than three high.
- 4 crossed chains and binders must be used per level.
- Binders and tag ends of chains must be wired.
- Two straps must be used per level.
- If trailers are stacked 3 high, landing gear must be fully retracted on top trailer only. (The reason is to limit any potential clearance issues.)

Small Boats



- Small boats shall be securely cradled.
- Cradle construction must be tied together both laterally and longitudinally.
- Cradle must be securely constructed and nailed or bolted into one solid unit.
- Boat must be banded or strapped to the cradle as well as to the platform.
- Single cut wedge blocks must be placed at all four corners of the cradling device.
- The boats pictured are well supported and strapped. The addition of wedges nailed to the corners of the cradle, then to the platform, would improve this load substantially.

Miscellaneous Small Equipment



- Small equipment must have at least two bands or straps securing each individual item.
- Softeners must be applied where bands / straps contact sharp edges.
- Items must be supported on bearing pieces. No metal to metal contact.
- All loads require 6:1 MBS securement.

Empty Platforms on Flat Car

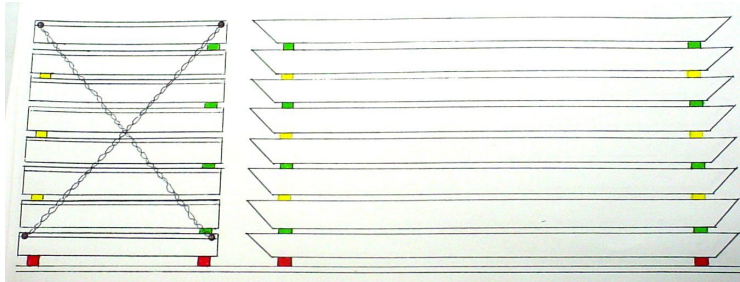

Twist locks are red. Stacking cones are yellow and green

Requirements for shipping empty platforms in a stacked configuration:

- Empty platforms must be clear of ice and snow.
- Platforms must be tightly stacked to ensure full engagement of stacking cones.
- Two stacking cones are required on each level and must be arranged in an alternating manner.
- Crossed chains and binders or hard chains and turnbuckles must be applied to each end of the stack.
- Binders and / or turnbuckles must be wired.
- Stacks must be firmly locked to the car deck using twist locks, or when stacks are not locked to the deck, the use of stub stakes is required.

Rail Loads on Flat Cars in a Revenue Train



Flat Cars without Bulkheads

- Bearing pieces must be 4x6 hard wood **and** equal to the width of the car deck.
- Two bearing pieces must be located **5** feet from each end of the load, with **5** more evenly spaced between them **which equals 7** pieces' total.
- Separators must be a 1x3 located between all levels directly above the bearing pieces. Separators should extend **2** inches beyond the load on each side.
- Banding must be **2** inches, with the end two located approximately **5** feet from each end of the load. **5** additional bands must be evenly spaced between them, encircling the entire load. Softeners must protect the bands at the bottom edges of the load.



- Filler blocks must be 3 ½ x 5 ¼ x 24 inches long. Center fillers **are required** in the top outside row at the point where the bands are located.



- Side stakes must extend 14 inches below the stake pocket and fully engage the uppermost rail on the side of the load.
- Side stakes must be firmly nailed in place to prevent movement.



Flat Cars Equipped with Bulkheads

- Bearing pieces must be 4x6 hard wood **and** equal to the width of the car deck.
- Two bearing pieces must be located **5** feet from each end of the load, with **5** more evenly spaced between them **which equals 7** pieces' total.
- Separators must be a 1x3 located between all levels directly above the bearing pieces. Separators should extend **2** inches beyond the load on each side.
- Five or more **2**-inch web straps must secure the load deck to deck.
- Four steel side stakes must protect the load from lateral movement.

Railroad Ties on Flat Cars in a Revenue Train



- Tie loads must have three-3 inch straps on the end stacks and at least two 2 inch straps on all the other stacks.



- Each bundle must have two-1 ¼ inch bands. Each stack must have at least two-2 inch, or three-1 ¼ inch unitizing bands.



- Bundles should be built five ties wide by four ties high. Bearing piece should be 4x6 lumber positioned to be wider than it is high. Hardwood should be used if possible. Multiple layers of separators must be arranged in a vertical manner.

Canvas Sided Trailers



The Alaska Railroad Corporation does not accept canvas sided trailers for rail transport.

The ARRC will accept canvas sided box trucks with one exception, the canvas sides must be secured with either cords straps or nylon straps. The number of cord straps or nylon straps to be used will be based on size **with a minimum of 4 straps starting out**. Attached you will find examples of canvas sided box trucks with 5 cord straps applied.

This memo does not apply to canvas sided trailers. See current load manual for example.



Chain Equipped Flat Cars



- Wheel chocks are not required for chain equipped flat cars.
- Chains that are not used must be securely stowed inside the chain rails to prevent dragging chains during transit.
- Be careful when wrapping chains around axles. They are to be secured to keep them from damaging air lines, shocks, brake lines, etc.
- Exercise care when loading / unloading tracked equipment to keep them from damaging chain rails and chain sets.
- Make sure the load is centered on car.
- Report damaged chains or chain rails.
- Chain capacity is **45,200** LBS.
- Remove nails and loose debris from the deck and chain rails.
- Whenever possible, pull the chain at a 45-degree angle.
- Secure outriggers.
- **Install straps** over trailer tongues and boom masts.
- Secure any loose stowed items with **wire**.
- Ensure rail car brake staff is down prior to loading.
- Do not secure chains around hydraulic cylinders.
- Chain sets can be moved from rail to rail.



- Make sure boom equipped loads are **spotted** with **the** boom trailing in **the** direction of travel.
- Mobile loads, such as vehicles, crawlers, trailers etc. must be secured to a minimum of **6:1 MBS** of the loads own weight.
- **Chain at a 45-degree angle when possible** from the deck, pulling in both directions on the load.
- Contact the ARRC with any concerns of excessive height and width, as well as final clearance.

Trailers with Drop Axles



- Trailers with drop axles, that are to be placed on a 191xx series articulated flat cars must have the axle properly chained to prevent the axle from dropping onto the top of center sill of the car, or onto the rail car wheels.
- Trailers with drop axles do not have to be chained if they are placed on an 187xx series rail car.
- Chains must be hooked back to the chain, binders wired, and the tail of loose chain wired to keep it from dragging.



Blocking Axles

The ARRC will no longer require blocking under the axles for roll-on equipment on railcars, vehicles on platforms or trailers. However, this does not **excuse** the requirement of wheel chocks for wheels where they can be nailed to the deck or platform. *If the load arrives having the axles already blocked then wheel chocking is not necessary.*



Light Trucks/Equipment Rated as 1 Ton or less:

Wheel chocks **are required to be nailed to the deck with the shorter acute angled side tight against the tires** in front of the front tires and behind the rear tires. If the light truck has dual rear tires, only one chock needs to be **nailed to the deck** behind one of the dual tires on each side. Wheel chocks **must be nailed to the deck** tight against the tire(s).



Trucks/Equipment Exceeding 1 Ton Rating:

Wheel chocks are **required to be nailed to the deck** in front of front tires and in front of **the 1st axel and behind the rear axle(s)**. Wheel chocks **must be nailed to the deck** tight against the tire(s).



Trucks/Equipment Exceeding Plate Width of Railcar:

For any tires that overhang the plate width of the railcar by greater than 40% of the total tire width, additional blocking must be applied to the inside of each tire on any axle that this applies to and must also be nailed to the deck of the railcar. Wheel chocks **must be nailed to the deck** tight against the tire(s).



Block Specifications: Wheel chocks are a minimum of 7x7x14 inch. If hardwood is used, pre-drilled holes must be drilled prior to the installation of the nails to prevent splitting.

Nail specification: Blocking must be applied to the car deck using four (4) 20-D nails in the heel, spaced wide enough to prevent block from twisting, and two (2) 20-D nails in each side of the block. Nails must be long enough to penetrate 1 ½ inches into the railcar deck.

Gondola Scrap Metal Loads Bound for Out of State

AAR Open Top Loading Rules Manual

Fig. 87 (Rev. 06/13)
(New 02/60)

SCRAP, METAL, LOOSE AND BALED—GONDOLAS

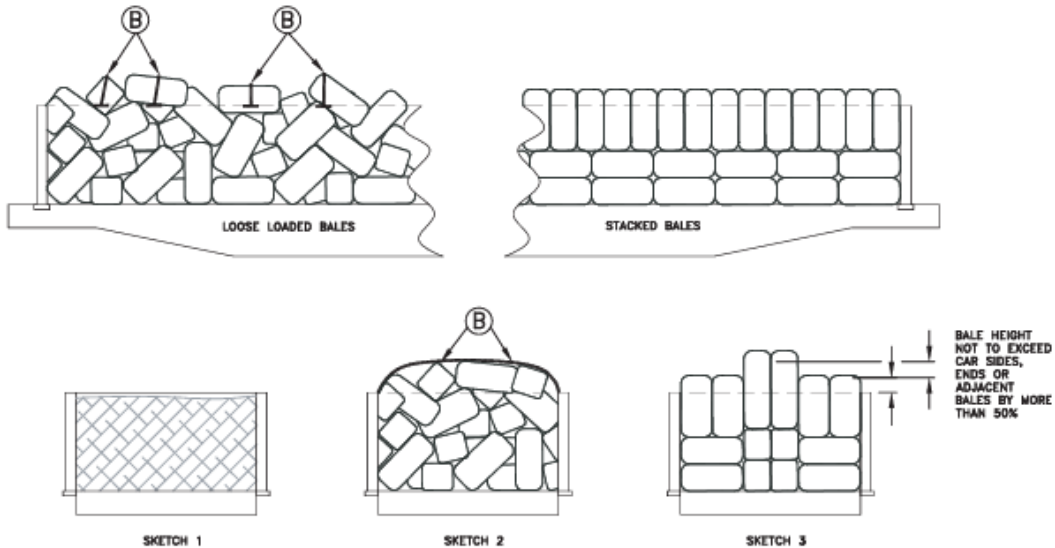

Item	No. of Pcs.	Description
A		Brake wheel clearance: see Section 1, General Rule 2.
B	2 per 8 ft or less of load length extending above car sides. Add 1 for each additional 4 ft of load length.	High tension bands: 2 in. x .044 in. Locate to contact and secure top baled scrap not in compliance with Note 1.
C	As required. (not shown in drawing)	Wire mesh or netting: of sufficient strength, width, and length to cover complete top of car. Secure to lading strap anchors. Do not secure to safety appliances, such as handholds and ladders. Not required when loaded to provisions of Notes 3 and 4.

Notes and Additional Requirements:

1. Baled scrap, extending above car sides and ends must engage car sides, ends and adjacent bales by minimum of 50% of bale. See Sketch 3.
2. Light scrap metal (e.g., loose tin or aluminum stampings, etc.) must be secured with wire mesh, netting and/or material of equal strength to prevent displacement by suction in transit. Heavy or baled scrap may be substituted and loaded on top of light material provided height limitation of Note 1 is not exceeded.
3. Loose scrap metal must be below top of car sides and ends of the car at any point of load. See Sketch 1.
4. Light scrap metal loaded 12 in. below top of car sides and ends requires no securement or covering.
5. Load weight must be evenly distributed end to end and side to side.

Reference the General Rules in Section 1 of the *Open Top Loading Rules Manual* for additional details.

Plate C

If open top load dimensions are outside of this guide, it will need clearances from the ARRC before movement.

- Clearances are required if the load exceeds plate C, or if the load overhangs the side sill or past the striker of the car.

EQUIPMENT DIAGRAM FOR LIMITED INTERCHANGE SERVICE (WILL CLEAR OVER 95% OF TOTAL MILEAGE) STANDARD ADOPTED, 1963; REVISED: 1966, 1986, 1987, 1991	
ASSOCIATION OF AMERICAN RAILROADS SAFETY AND OPERATIONS	
DATE: AUGUST 1, 1991	PLATE C

Unrestricted on all roads except on certain routes. For specific restricted areas on such roads see "Railway Line Clearances."

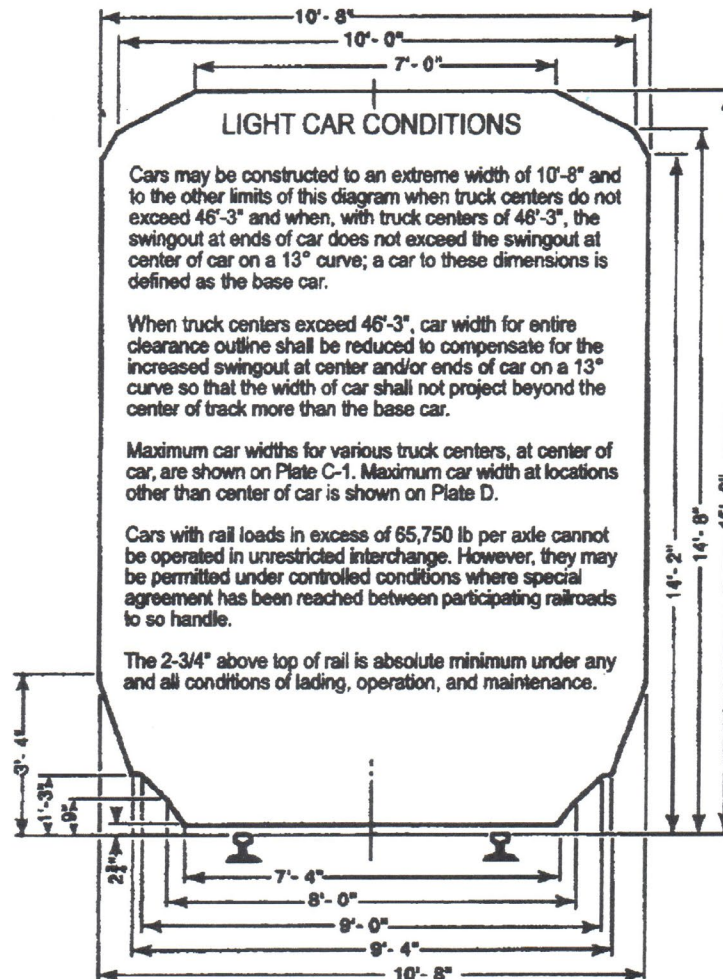

How to Load a Railcar, Trailer or Platform for the Alaska Railroad

3. WEIGHT DISTRIBUTION AND LOAD LOCATION ON SINGLE CARS AND INTERMODAL TRAILERS AND CONTAINERS

3.1 Unless otherwise specified, the load distribution covered in this rule applies only to general service cars.

3.1.1 Flat racks with foldable bulkheads must have bulkheads raised and properly locked for loaded moves.

3.2 Unless otherwise allowed in specific figures, all load weights must be equally distributed end-to-end and side-to-side at origin. If ballast is needed to equalize weight distribution, refer to Rule 3.4.2.

3.3 For load distribution on 85-ft and 89-ft flatcars, including converted TOFC/COFC and multilevel flatcars, the shipper and originating carrier must confer with the car owner.

3.4 Load Distribution

3.4.1 Weight Limits

3.4.1.1 Truck Limits

The weight of load on a car must not exceed the load limit stenciled on the car. The weight of load on one truck must not exceed one-half of the load limit stenciled on the car. In case of doubt, this must be verified by weighing the car.

3.4.1.2 Lateral Limits

The load must be located so that the weight along both sides of the car is equal for the entire length of the load.

3.4.1.3 Floor Limits

Commodities having a concentrated load bearing footprint cannot exceed the floor rating of the car. If floor rating is unknown, use 130 psi on a wood deck car; 430 psi on a 3/8 in. steel deck/nailable steel floor; and 740 psi on a 1 in. steel deck car, at any point on the car deck. The car deck must be in suitable condition. If in doubt, contact the serving railroad.

3.4.1.4 Center of Gravity Limits

3.4.1.4.1 The combined center of gravity (CCOG) of the car and load must be at 98 in. or less above top of rail. If CCOG exceeds 98 in. above top of rail, load may be classified as a dimensional shipment and requires railway clearance and special handling (see General Rule 4). Contact origin carrier for further direction. (CCOG formula is provided in Part 5.)

3.4.1.4.2 Large and heavy material such as ingots, slabs, billets, molds, castings, machines, etc., not covered by individual figures, must be loaded with the largest dimension on the bottom for greater stability.

3.4.1.5 End-of-Car Limits

3.4.1.5.1 Load weight, uniformly distributed from truck centers to ends of car, must not exceed 15% of the stenciled load limit on each end. (See Fig. 3.1, Sketch 1.)

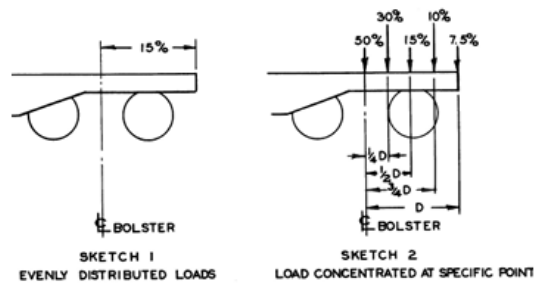

Fig. 3.1 Weight distribution from truck center to end sill

3.4.1.5.2 Point or concentrated loading between body bolster and end sill must not exceed the percentages shown in Table 3.1. (See Fig. 3.1, Sketch 2.)

Table 3.1 Load concentration between body bolster and end sill

Location of Load or Bearing Piece	Permissible Concentrated Load Percentage of Stenciled Load Limit
C/L of bolster	50%
1/4 distance between bolster center and end sill	30%
1/2 distance between bolster center and end sill	15%
3/4 distance between bolster center and end sill	10%
At end sill	7.5%

3.4.2 Ballast

3.4.2.1 If the weight of a load cannot be equally distributed across a car, suitable ballast must be used to equalize the weight. The counterweight ballast must be secured in accordance with General Rule 5. The weight of the counterweight and its securement must be considered part of the total load weight and meet proper load distribution requirements. The structural integrity of the counterweight/ballast, regardless of its construction material, must be sufficient to withstand securement to the car and rail forces as defined in General Rule 5.3.

3.4.2.2 To determine how much ballast is required to balance the load, take the weight of the load in pounds (W); multiply it by the distance of the center of gravity from the centerline of the load relative to the centerline of the railcar in inches (D); and divide by the distance in inches (d) available on the car to offset the imbalance.

$$\text{Weight of ballast} = \frac{W \times D}{d}$$

3.4.2.3 To determine the location of the given weight of the ballast in pounds (w) to offset the imbalance, take the weight of the load in pounds (W); multiply it by the distance of the center of gravity of the load relative to the centerline of the railcar in inches (D); and divide by the ballast weight in pounds.

$$\text{Location of ballast from centerline of car} = \frac{W \times D}{w}$$

3.4.3 Securement

3.4.3.1 Regardless of the vacant space across a car, the load must be secured to prevent any portion of the load from shifting, resulting in a potential off-balance condition and/or displacement of the load from the car.

3.4.3.2 Unless otherwise specified in a figure, all tubular products in the same layer must be of the same height. Not applicable for loads with maximum height below top of gondola car sides.

3.4.3.3 Machines and other items having high centers of gravity or narrow bases must be secured to ensure their stability in transit.

3.4.3.4 Partial unloading of a commodity from a car is not recommended. In the event that a load is partially unloaded, the remainder of the load on the car must comply with, or be arranged to comply with, an existing figure or the General Rules before further movement.

3.4.4 General Load Distribution

3.4.4.1 For proper load distribution on general service cars only, the percentages of stenciled load weight limits listed under this rule must not be exceeded unless the car owner has otherwise designated, either by note in the Official Equipment Register that these percentages may be changed or by providing specific permission in writing.

3.4.4.2 When the load is lapped or staggered between truck centers and covers about the full length of the car and the weight of the load does not exceed the stenciled load limit of the car, the requirements of Rule 3.4.4.1 do not apply.

3.4.4.3 Fig. 3.2 applies to all flatcars built after January 1, 1965, including flatcars equipped with both fish-belly center sills and fish-belly side sills. This does not apply to 85 ft and 89 ft flatcars. Refer to General Rule 3.3 for 85 ft and 89 ft flatcars.

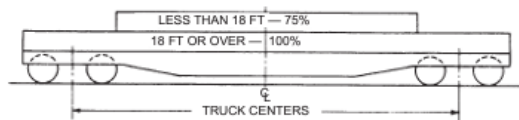

Fig. 3.2 Flatcars built after January 1, 1965

3.4.4.4 Fig. 3.3 applies to 70 ton, low-level, flush deck cars (28 in. wheel), except flatcars equipped with both fish-belly center sills and fish-belly side sills.

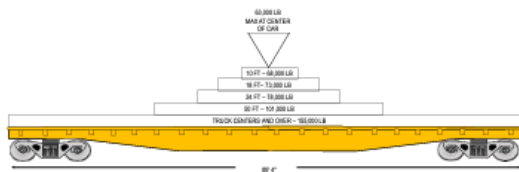

Fig. 3.3 Loading configuration of 70 ton, low-level, flush deck car (28 in. wheel)

3.4.4.5 Fig. 3.4 applies to a 70 ton, standard-level, flush deck cars (33 in. wheels), except flatcars equipped with both fish-belly center sills and fish-belly side sills.

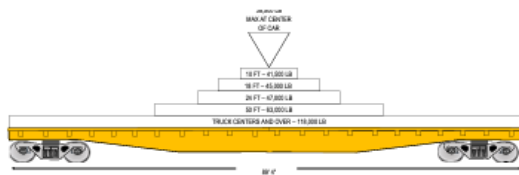

Fig. 3.4 Loading configuration of 70 ton, standard-level, flush deck car (33 in. wheels)

3.4.4.6 Fig. 3.5 applies to a loading configuration of 110 ton, 89 ft, XTTX cars (36 in. wheels), except flatcars equipped with both fish-belly center sills and fish-belly side sills.

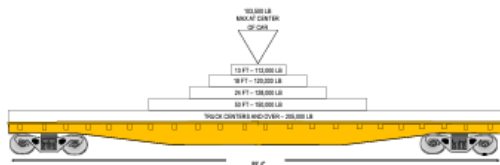

Fig. 3.5 Loading configuration of 110 ton, 89 ft, XTTX car (36 in. wheels)

3.4.4.7 Fig. 3.6 applies to all gondola cars.

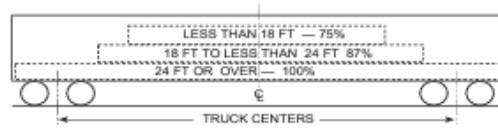

Fig. 3.6 Gondola load distribution

3.4.4.8 The weight concentration percentages shown in the figures under Rule 3.4.4.1 are based on the center of load weight (that is, the center of gravity of the load) being located on the center of the car length. The center of the load weight must not be nearer to either truck center than the distances shown in Table 3.2 based on the corresponding reduction in load weight. These distances are calculated so as not to exceed one half the load weight at either truck.

Table 3.2 Positioning load weight center

When load weight is reduced to...	Position of load weight center should be...
66.6%	1/4 distance between truck centers.
75%	1/3 distance between truck centers.
87%	3/7 distance between truck centers.
90%	9/20 distance between truck centers.

3.4.4.9 The distance between crosswise bearing pieces (center to center) under lapped or staggered portion must be placed so as to prevent excessive concentration of weight over specified spaces shown in the above tables.

3.4.4.10 It is permissible to provide for extended load distribution by using bearing pieces that are of suitable strength and length, placed lengthwise of car to distribute the load weight over the spaces specified in Table 3.2.

3.4.4.11 When crosswise bearing pieces are used, the distance between the outside bearing pieces (center to center) must not be less than the minimum distance specified in the above tables.

3.4.4.12 When a load is prepared on two or more cars, with or without overhanging support, the weight carried on one bearing piece is not to exceed the percentage of stenciled load weight limit, as shown in General Rule 30, Tables 30.3 through 30.14, depending on the class of car as shown in the tables.

3.5 Load Distribution—Center Beam Flatcars

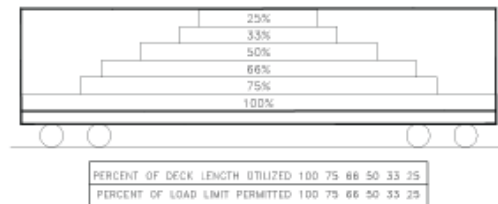

Fig. 3.7 Load distribution on typical center beam flatcar

3.5.1 Fig. 3.7 refers only to cars originally constructed as center beam cars.

3.5.2 The center beam flatcar is not a general purpose flatcar. Therefore, if the full length of the deck is not utilized, loads must be reduced in accordance with Fig. 3.7, except where stenciling on the car indicates car construction is capable to withstand load concentrations over less than the full deck length or permission is given by carrier and car owner.

3.5.2.1 On center beam railcars equipped with steel risers, no part of the load shall contact the car floor between risers.

3.5.3 Any loading not covered by a specific figure must be approved by the originating carrier as covered in Rule 1.3.

3.5.4 Load must be equally distributed on both sides of the center beam partition.

3.6 Load Distribution—Gondola Cars

Regardless of the amount of vacant lateral space on the car, the load must be secured so as to prevent moving or tipping toward the sides of the car. Exceptions to this rule are allowed only where specified in approved figures.

3.7 Load Distribution—Hopper Cars

Load weight must be evenly distributed end to end and side to side. If the mounding of loaded material presents the potential for violating this even distribution should it settle to one side of the car or the other, the height of mound must be reduced accordingly.

3.8 Load Distribution—Trailers and Containers

3.8.1 The weight of lading and trailer must not exceed regulatory requirements for North American highway transport.

3.8.2 Trailers are designed for uniform load distribution. Lading must be distributed equally between the rear tires and the fifth wheel. Concentrated loads must be positioned over rear wheels first and then over fifth wheel if needed.

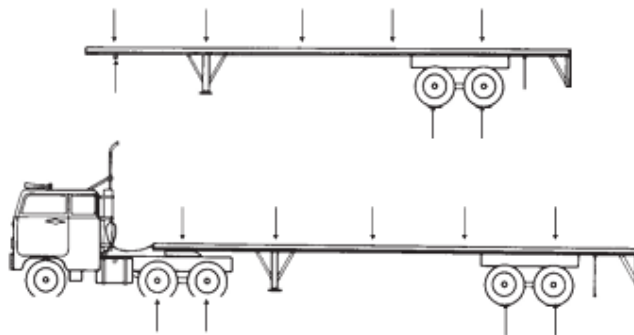

Fig. 3.8 Weight distribution on trailer

3.8.3 Crosswise weight must be equally distributed.

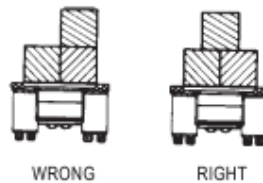

Fig. 3.9 Crosswise weight distribution on trailer

3.8.4 The figures in Part 3 and Part 4 of Section 7 of the Open Top Loading Rules illustrate the securement items and do not necessarily show the correct weight distribution to comply with Rule 3.8, which shall govern.

3.8.5 The load must be located so that the weight along both sides of the trailer is equal for the entire length of the load. If the weight of a load cannot be equally distributed across the trailer, suitable ballast must be used to equalize the weight. The counterweight ballast must be secured in accordance with Rule 5.3 of this Part. The weight of the counterweight and its securement must be considered part of the total load weight.

3.8.6 Regardless of the vacant space across a trailer, the load must be secured to prevent any portion of the load from shifting, resulting in a potential off-balance condition and/or displacement of the load from the trailer.

3.8.7 Large and heavy material such as ingots, slabs, billets, molds, castings, machines, etc., not covered by individual figures, must be loaded with the largest dimension on the bottom for greater stability.

3.8.8 Unless otherwise specified in a figure, all tubular products in the same layer must be of the same height.

3.8.9 Machines and other items having high centers of gravity or narrow bases must be secured to ensure their stability in transit.

3.8.10 Partial unloading of a commodity from a trailer is not recommended. In the event that a load is partially unloaded, the remainder of the load on the trailer must comply with, or be arranged to comply with, an existing figure or the General Rules before further movement.

4. LOAD DIMENSION AND WEIGHT RESTRICTIONS

4.1 The height, width, and length of a load on one car for unrestricted movement must be within the “Outline Diagram for Single Loads, Without End Overhang, On Open Top Cars” as published in the “Railway Line Clearance” section of the *Official Railway Guide*, and in Appendix A, page 233.

4.2 Refer to Part 5 for recommended procedures for measuring loads that exceed published railway line clearances and the method of determining combined center of gravity above top of rail.

4.3 Loads of dimensions and/or weight that make it necessary to handle them under restricted speeds must be reported by the originating carrier to all carriers involved in the shipment’s routing.

4.4 The dimensions for single loads having end overhang, and those loaded on two or three cars, must be in compliance with General Rules 29 and 30.

4.5 Loading tracked machinery/vehicles with treads extending (laterally) beyond the floor of the car is permitted, provided the machine/vehicle is centrally located on the car and not more than one half of the tread extends beyond the outside face of the side sill.

4.6 Shippers and originating carriers must verify clearances over the entire route for any load having one or more dimensions exceeding the above-referenced outline diagram or as shown in General Rules 29 and 30. This rule does not authorize shippers to exceed height, width, or length dimensions when shown in specific figures.

4.7 Trailers with Load Overhang

Loads that are longer than the trailer must be within the following limitations for load overhang.

4.7.1 The overhang must not project beyond the end sill of the flatcar on which the trailer is loaded unless an idler car is used.

4.7.2 The length of the overhang measured from the end of the trailer (or end bearing piece when used) is not to exceed 25% of the length of the load. If the load consists of more than one pile, the 25% limitation applies to the length of the end pile containing the overhang. Individual pieces not exceeding 10% of the total number of overhanging pieces in the load may exceed the 25% overhang limit if all other conditions are met.

4.7.3 The length of the overhang, even within the 25% limit, shall be of such length as not to produce injurious bending or deformation of the load or pieces in the load because of weight or conditions incidental to TOFC movements. The length of the overhang in this case will depend upon the weight, cross section, and strength of the material in the load.

4.7.4 For any objects subject to rotating or swinging, refer to Rule Rule 6.

5. LOAD RESTRAINT

5.1 Load Restraint Types

5.1.1 Floor Blocking

Lumber or steel dunnage is secured to the railcar via fasteners (nails or bolts) or fastening agents (weld). The primary purpose is to prevent movement of the load on the car by blocking around points or perimeter of the load.

5.1.2 Tie-Downs

Tie-downs can be any material (cable, rod, strap, chain, flat bar) used to generally secure the load above the floor to an anchoring point on the car.

Glossary

Banding, application:

Securement: **Banding** that anchors or ties down a load to the car; **this could be straps, chains or cord lashing**; on a floating load, it can be an encircling band or interlacing band.

Package: **Banding** that holds one or more pieces together to form a package.

Interlacing/Unitizing: **Banding** that holds two or more packages together to form one unit. *Example: If there are 3 packages stacked, the first layer is banded to the second, and the second layer is then banded to the third layer, unitizing the whole load. This goes for any amount of layers – 1st to the 2nd, 2nd to the 3rd, 3rd to the 4th etc.*

Encircling Banding that wrap around the load.

Bearing Piece: Material placed on a car, trailer floor or platform, underneath lading, to facilitate loading or unloading; to maintain 4 inches of clearance below overhanging portion of load and any part of an idler car or cars; and to distribute weight of lading over the floor of a car or trailer.

Binder: A device that consists of a link and hook on each end with a concentric lever to apply tension to a chain assembly.

Blocks: Wood material, nailed, bolted, or wired in position to secure lading in place.

Braces: Material used to retain lading or blocking in position.

Clamping Piece: Wood member placed across top of load to keep lading in position, secured to car, trailer, or stake pockets with rods. Also used on machinery or vehicles to secure moveable parts.

Chocks: Wooden or plastic triangular pieces installed on the deck of a car, on the top and bottom of bearing pieces and separators, to prevent lading from rolling and shifting from its secured position.

Cleats: Wooden pieces secured to floor to reinforce blocking. Pieces secured to floor or blocking against lading to retain lading in position.

Cribbing: Metal or wood pieces placed under or against lading as a supplement to the primary load support to stabilize or hold lading in position.

Design Safety Factor (polyester webbing): A term denoting the webbing's theoretical reserve capability. This is computed by dividing the minimum breaking strength (MBS) by the working load limit (WLL), often expressed as a ratio, e.g., 3:1, or 3 to 1, etc.

Design Safety Factor (chains): A term denoting a product's theoretical reserve capability. Computed by dividing the minimum breaking strength by the working load limit and expressed as a ratio, e.g., 4:1 or 4 to 1. (Unless otherwise specified in these rules, the design factor of a chain must meet or exceed the current specifications published by the National Association of Chain Manufacturers [NACM]. This does not apply to equipment placed into service prior to September 1, 1996.)

Edge Protector: A device placed on the exposed edge of lading to distribute the forces over an area larger than the contact area of the tie down itself to prevent damage to the tie down or lading and to allow the tie down to freely slide when being tensioned.

End Blocking: Blocking used to prevent end movement of lading.

Floating Load: A load in which the lading is prepared into a unit with space between unit and ends of car/trailer and end blocking is omitted. This kind of load permits the dissipating of impact shocks by the lengthwise movement of lading over the floor of the car or trailer.

Hardcore Paper: Treated cardboard that resists decomposition due to moisture. Usually a softener.

Minimum Breaking Strength (polyester webbing): The minimum tensile load (in pounds) at which the webbing fails.

Minimum Breaking Strength (chains): The minimum load at which the securement, component, or assembly has been found by representative testing to fail when a constantly increasing force is applied in direct tension. This is also referred to as demonstrated breaking force or ultimate load. This is a manufacturer's statistical attribute acceptance test.

Pallet: A platform or skid on which lading is placed and secured; used to facilitate handling of small sized commodity shipments by mechanical means.

Polyester Webbing: Typically used in systems where low elongation and low creep are desirable. Polyester's higher density allows thinner webbings than nylon at equal strengths. Polyester has better resistance to moisture than nylon, although some coatings allow approximately equal performance of both types.

Separators: Material placed **perpendicular** between each layer of a load extending through the full width of load to facilitate loading and unloading; to provide level support for additional layers, and to provide an application of load securement items.

Spacers: Material placed crosswise between layers of a pile, extending for the width of pile only to facilitate loading and unloading, and to provide space for the application of load securement items.

Stake: A piece of timber or metal inserted in the stake pocket on the sides or ends of flat cars or open top trailers, **that extends high enough over the top of the load for cord lash securement** to hold the load in place. Also used on inside of gondola cars to secure lading in position.

Stub Stake: A piece of timber or metal inserted in the stake pocket on sides or ends of flat cars or open top trailers to hold load in place and that extends sufficiently above floor to provide protection against side or end movement of lading.

Sticker: Material placed crosswise within a bundle that extends only the width of the bundles. Stickers provide rigidity and prevent slippage of individual pieces within bundles.

Strapping, non-metallic: Synthetic materials of various widths and thickness, each with standard load strengths, used to secure lading.

Wheel Chock: Concave or mitered blocking pieces used to secure wheeled units in position.

Working Load Limit (polyester webbing): The stated capacity of a web strap, specified as a fraction or ratio of the minimum breaking strength (MBS). Example: If the MBS is three times the WLL (or the WLL is one-third of the MBS value), then the design (safety) factor is said to be a ratio of 3:1 or *MBS to WLL = 15,000 lb to 5,000 lb = 3 to 1*

Working Load Limit (chains): Working Load Limit (WLL). The maximum load (rated capacity) for which the chain, component, or assembly is authorized when the pull is applied in direct tension to an undamaged straight length of chain.

Table 20.1 Approved webbing companies

Company	Ref. Part No.	Type and Width of Webbing	Web MBS	AAR Marking*	Approved Through (mm/yy)
			lb (kg)		
Oppermann Webbing Inc.	P/N 6624102-93	4-in.-wide woven polyester, resin coated.	20,000 (9072)	AAR-76M	01/19
Spanset, Inc.	P/N 141534	LoadGard(tm) woven polyester, uncoated, 4.0 in.	20,000 (9092)	AAR-72MA	02/17
Spanset, Inc.	P/N 152622	LoadGard(tm) woven polyester, coated, 4.0 in.	20,000 (9092)	AAR-72MA	02/17
Southern Weaving Co.	P/N 1257LP0200	2-in. wide woven yellow dyed 40148 polyester.	12,000 (5443)	AAR-73M	01/18
Southern Weaving Co.	P/N 1257LP0300	3-in. wide woven yellow dyed 40148 polyester.	18,000 (8165)	AAR-73M	01/18
Southern Weaving Co.	P/N 1257LP0400	4-in. wide woven yellow dyed 40148 polyester.	24,000 (10886)	AAR-73M	01/18
Southern Weaving Co.	P/N 1527XP0200	2-in. wide woven yellow dyed 40148 polyester.	10,000 (4536)	AAR-73M	01/18
Southern Weaving Co.	P/N 1527XP0300	3-in. wide woven yellow dyed 40148 polyester.	15,000 (6804)	AAR-73M	01/18
Southern Weaving Co.	P/N 1527XP0400	4-in. wide woven yellow dyed 40148 polyester.	20,000 (9072)	AAR-73M	01/18
American Webbing Inc.	P/N 05004TPT	4-in. wide woven yellow dyed polyester.	20,000 (9072)	AAR-77M	08/16
Ribbon Webbing Corp.	P/N P6000-2-314	2-in. wide woven yellow dyed polyester.	12,000 (5443)	AAR-81MA	07/18
Ribbon Webbing Corp.	P/N P5000-4-314	4-in. wide woven yellow dyed polyester.	20,000 (9072)	AAR-81MA	07/18
Ribbon Webbing Corp.	P/N P6000-4-314	4-in. wide woven yellow dyed polyester.	24,000 (10886)	AAR-81MA	07/18
Kinedyne Corporation	P/N 4084F	4-in. wide woven gold dyed polyester	24,000(10886)	AAR-71MA	10/19
Carolina Webbing	P/N TPY 6002	2-in. wide woven yellow dyed polyester.	12,000 (5443)	AAR -80M	02/20
Carolina Webbing	P/N TPY 5004	4-in. wide woven yellow dyed polyester.	20,000 (9072)	AAR -80M	02/20
Pacific Cargo Control	WBA4 – 20M –NP	4-in. wide woven polyester	20,000 (9072)	AAR -75MA	11/18
Pacific Cargo Control	WBA4 – 24M –NP	4-in. wide woven polyester	24,000 (10886)	AAR -75MA	11/18
Ancra International	P/N 43797-36-R	4-in. wide woven polyester	20,000 (9072)	AAR – 74L-MA	05/19
Ancra International	P/N 41632-44-xxxR	4-in. wide woven polyester	24,000 (10886)	AAR – 74L-MA	05/19
Cargo Equipment Corp.	747Y-2	2-in. wide woven yellow polyester	12,000 (5443)	AAR-84LA	08/20
Cargo Equipment Corp.	747Y-3	3-in. wide woven yellow polyester	18,000 (8165)	AAR-84LA	08/20
Cargo Equipment Corp.	888Y-4	4-in. wide woven yellow polyester	20,000 (9072)	AAR-84LA	08/20

* **M** = Approved weaver/manufacturer
MA = Approved weaver and assembler



Association of American Railroads
Current as of June 23, 2023
This table corresponds with AAR Open Top Loading Rules, Section 1, Table 19.2

Manufacturer/ Distributor	Approved through (Mo/Yr)	Grade 3 ^{a/}		Grade 4 ^{b/}		Grade 5 ^{c/}	
		AAR ID (Part No.)		AAR ID (Part No.)		AAR ID (Part No.)	
		(¾") MBS (LBS) 1,585	(1") MBS (LBS) 2,100	(1 ¼") MBS (LBS) 3,285	(1 ½") MBS (LBS) 4,400	(1 ¼") MBS (LBS) 4,200	(1 ½") MBS (LBS) 5,400
Polychem Mex Acquisition, S. DE R.L. DE C.V DBA Greenbridge	07/24	AAR-5 60WGHD+ N8HD Buckle		AAR-5 105WGSD+ CB10A Buckle 105WOSD+CB32 Buckle			AAR-5 125WOSD+Ladder Buckles (OWB3035DF and BN1431
Carolina Strapping GatorSTRAP	04/26	AAR-80 CS-2025: CSB-3025 Wire Buckle		CS-2040: CSB-3035 Wire Buckle CSB 9082 Ladder Buckle		CS 8030/8031: Hook CSB9076,Ladder Buckles - CSB 9080, CSB 9090	AAR-80 CS-2055: Ladder Buckle CSB 9090
Carolina Strapping MakoSTRAP	04/26			AAR-80 CS 5080+ CSB 9060 Wire Buckle			
Signode- AlleghenyIndustrial Associates/ Avistrap	02/24	AAR-11 Avistrap PW60SH: Wire Buckle A34HWBP		AAR-11 Avistrap PW100EH: Wire Buckle AVB30		AAR-11 Avistrap PW120: Ladder Buckle AVB9L	AAR-11 Avistrap PW120EH: Ladder Buckle AVB9L
TAPEX American Corp.	07/23			AAR-1 105WXH - Ladder Buckle FCT-10			AAR-1 125WXH - Ladder Buckle FCT-12
Polychem, LLC DBA Greenbridge	04/26	AAR-53 PC75TA + wire buckle SB34X17P		AAR-53 PC105TA + SB114XDP WireB or SB105LAD ladder buckle			AAR-53 PC150TXA + SB150LAD ladder buckle

Multitech Products Pvt. Ltd.	04/26			AAR-90 MPH 32 + Metal wire buckle B32		
Redback Industries	02/26			AAR-39 CW105RB + RLB30 Ladder Buckle; RBC105AAR Composite + RLB30 Ladder Buckle;		
Redback Industries	08/23					AAR-39 CW 125: Ladder Buckle - RFS40E
Cordstrap USA Inc.	02/25			AAR-77 CC105: Wire Buckle –CB10 Cordweb 105: HDB10C Ladder Buckle and CB10F Wire Buckle		AAR-77 Cordlash 105: Ladder Buckles – Dynablock 10 and HDB10N Cordweb 150: Ladder Buckles – HDB12C
Complete Packaging Systems, Inc. TEX-STEEL™	06/24			AAR-83 CPS 105 + CB10F Wire Buckle		AAR-83 CPS 125 + HD312 Wire Buckle
Complete Packaging Systems, Inc. “Composite”	06/24			AAR-83 CPS PC 105 + HD10G Wire buckle		
Buffers USA, Inc. THORSTRAP™	05/25					AAR-7 2911-7424 w/ Ladder Buckle (2911-7445-1.5)
Unifixx (C & S Valkenburg &Co) BV	01/25				AAR-85 W323+ B3030 (ladder)	
Shanghai Topack Logistics Equipment Co., Ltd	02/26			AAR-86 TW105+THB10N (ladder) TC105+TB10-P (wire)		AAR-86 TW150+THB12N (ladder)

Pacific Strapping Inc.	08/25			AAR-79 P-104W-AAR: Wire Buckle (B-104-AAR)			AAR-79 P-125W-AAR: Wire Buckle (B-125-AAR)
Samuel Strapping Systems, Inc.	09/24			AAR – 22 TY105+SSLB40 Ladder AW105 + SSLB40 Ladder			AAR – 22 AW125 + SSLB40 Ladder
Co-Strap	12/24			AAR – 98 CS32ESTR + Wire Buckle (GB32250700)			
USA Strapping	12/24			AAR – 92 CC105-AAR92 + 32MMHD Wire Buckle			
West Reading Strapping	09/25			AAR-23 11460039AAR + MB114PHHD Wire Buckle			
Narrowtex (Pty) Ltd.	07/25			AAR – 100 111NSAW + 31250- B Wire Buckle; NC105 + 31250-B Wire Buckle;			AAR – 100 NW103 + 31500-B Wire Buckle
Boss Tiedowns & Strapping	08/23					AAR – 112 BL5-114 + BLB35 Ladder	
Boss Tiedowns & Strapping	06/24			AAR – 112 BL4-114 + BLB114 Ladder			AAR – 112 BL5-112 + BLB112 Ladder
G&H GmbH Rothschenk	05/24					AAR-116 Lash 32 + Ladder Buckle 35 and Buckle Hook BHook35	
International Dunnage	10/24			AAR-511 IDSC105/32F + IDBG10/32 Wire Buckle			

Composite Strap India Pvt. Ltd.	01/25			AAR – 118 CS32MM + CSB32MM Galvanized Wire Buckle			
AtMet Group, Inc.	01/25			AAR – 501 Composite: SLC105 + BB10 Wire Buckle Woven: SL105 + HDB10 Ladder			
AtMet Group, Inc.	05/25						AAR – 501 Woven: SL 125 + HDB12 Ladder
LIFEX Polyester Corded Strapping	04/25	AAR – 120 LIFEX CHD25A + LWB25 wire buckle	AAR – 120 LIFEX CSHD25A + LWB25 wire buckle	AAR – 120 LIFEX CSHD32A + LWB32 wire buckle			
Caliber Packaging	06/25	AAR – 123 HD Woven + HD Phosphate Wire Buckle					
Atlas Dunnage Ambalaj San. ve Tic. A.Ş	05/26			AAR-502 Tufflash3215 w/ 3030DF ladder buckle		AAR-502 Tufflash 3223 w/ 3030 DF ladder buckle	AAR-502 Tufflash 3825 w/ 4040DF ladder buckle

^{a/} Strapping is acceptable for use as a substitution for steel package bands up to and including 3/4 in. x .028 in. only where substitution is specifically permitted in lumber figures in Section No. 5.

^{b/} Strapping is acceptable for use as a substitution for steel bands up to and including 1 1/4 in. x .031 in. under applicable lumber figures where substitution is specifically permitted in Section No. 5, unless otherwise specified.

^{c/} Strapping is acceptable for use as a substitution for steel bands up to and including 1 1/4 in. x .035 in. in all figures except for steel product figures with sharp edges.

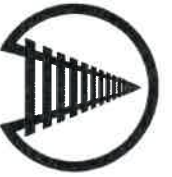

Association of American Railroads

*Open Top Loading Rules Committee
otr@aar.com*

Current as of June 23, 2023

This table corresponds with AAR Open Top Loading Rules, Section 1, Table 19.3

AAR Approved Type IA Polyester Strapping Grades 6 thru 8							
Manufacturer/ Distributor	Approved through (Mo/Yr)	Grade 6		Grade 7		Grade 8	
		AAR ID Width – 1 5/8"	MBS lb (N) 7,700 (34265)	AAR ID Width – 1 5/8"	MBS lb (N) 11,000 (48930)	AAR ID Width – 2"	MBS lb (N) 15,000 (66723)
Cordstrap USA Inc.	06/23	AAR-77 Cordlash 150 - Hooks (CDBH12,CDBH12 Extended) and Ladder Buckles (HDB12C, HDB12N and Dynablock 12N-150)	X	AAR-77 Cordlash 200 – Hooks (CDBH12, CDBH12 Extended) and Ladder Buckles (HDB12N and Dynablock 12N-150 and 12N-200)	X	AAR-77 Cordlash 750 – Hooks (CDBH12E-R Extended and CDBH15) and Ladder Buckles (HDB15N and Dynablock 15)	X
Carolina Strapping Gator/LASH	04/26	AAR-80 CS 8040/8041 - Hook (CSB-9077 Extended) and Ladder Buckles (CSB-9090, CSB-9091)	X	AAR-80 CS 8050/8051 – CSB-9076 Ladder Hook CSB-9091 Ladder Buckle	X	AAR-80 CS 8070/8071 CSB-9078 Extended Hook CSB-9079 Ladder Hook CSB-9096 Ladder Buckle	X
TAPEX American Corp.	07/23	AAR-1 135WXH – Ladder Buckle FCT-13	X				
Polychem Mex Acquisition, S. DE R.L. DE C.V DBA Greenbridge	11/24	AAR-5 Carilash C AG40+ BN1431 ladder buckle Carilash AG40+ BN1431 ladder buckle	X	AAR-5 Carilash AG50+BN1431 ladder buckle	X	AAR-5 Carilash AG75+ LG75 ladder buckle	X

*MxV Rail, 350 Keeler Parkway, Pueblo, Colorado 81001
MxV Rail is a subsidiary of the Association of American Railroads*



Redback Industries	08/23	AAR-39 RL 150 + Ladder Buckles RFS40E and RFS40DLB	X				
Redback Industries	02/26			AAR-39 RL200 + RLB40DLB Ladder Buckle	X	AAR-39 RL750 + RLB50DLB Ladder Buckle	
Buffers USA, Inc THORSTRAP™	05/25			AAR-7 2911-7426 + Ladder Buckle (2911-7445-1.625)	X		
Unifixx (C & S Valkenburg &Co) BV	01/25			AAR-85 W460 + B4050 Ladder	X		
Shanghai Topack Logistics Equipment Co., Ltd	02/26	AAR-86 TW150H+THB12R Ladder Buckle	X	AAR-86 TW200+THB12R Ladder Buckle	X	AAR-86 TW750+THB14N Ladder Buckle	X
Narrowtex (Pty) Ltd.	08/24	AAR-100 NW 152 + OWB 4050FL Ladder Buckle	X				
Samuel Strapping Systems, Inc.	09/24	AAR - 22 AW177 + SSLB40 Ladder	X				
G&H GmbH Rothschenk	05/24			AAR-116 Lash 40 + Ladder Buckle 40 and BHook40	X		
Complete Packaging Systems, Inc. TEX-STEEL™	06/24	AAR-83 CPS 150 + HDB35N Ladder buckle	X				
Co-Strap	12/24	AAR-98 COLASH150 + COLF4050	X	AAR-98 COLASH200 + COLF4050	X	AAR-98 COLASH750 + COLF5050	X

MxV Rail, 350 Keeler Parkway, Pueblo, Colorado 81001
MxV Rail is a subsidiary of the Association of American Railroads



USA Strapping	12/24	AAR – 92 7700-AAR92 + 40MMLBF	X	AAR – 92 11000-AAR92 + 40MMLBX	X	AAR – 92 15000-AAR92 + 50MMLBF	X
AtMet Group, Inc.	01/25	AAR – 501 SL150 + HDB12 Ladder	X	AAR – 501 SL200 + HDB12 Ladder	X		
Sandax GmbH	04/25			AAR – 121 Sandax 200 + S40G Ladder	X		
LINDER GmbH	08/25	AAR – 113 LS150+OWB4050DF ladder	X	AAR – 113 LS200+OWB4050DF ladder	X		
Atlas Dunnage Ambalaj San. ve Tic. A.Ş	05/26	AAR-502 Tufflash 3835 w/ 4040 DF ladder buckle	X	AAR-502 Tufflash 4050 w/ 4040 DF ladder buckle	X		
BOSS Tiedowns & Strapping	05/26	AAR-112 BOSSLash 150 (BL6-158) w/ BLB4040 ladder buckle	X	AAR-112 BOSSLash200 (BL7- 158) w/ BLB4040 ladder buckle	X		

Reference Section 1 General Rule 25 for allowable substitutions.

Reference to Section 1, GR 19.1.2: Non-metallic strapping must be used with metal edge protectors, designed specifically for type of strapping being used, and sufficient to provide a suitable radius to protect bands at stake pockets, slotted holes in car sides, and all points having sharp edges and/or acute angles on either equipment or lading.

