



Alaska Railroad Corporation  
327 W. Ship Creek Avenue, Anchorage, AK 99501  
P.O. Box 107500, Anchorage, AK 99510-7500  
GoemerG@akrr.com

September 19, 2019

## Invitation to Bid

#19-37-207488

### ARRC Passenger Coach Painting and Repair: ARR 200 and ARR 201

#### Cover Sheet

**Response Required:** This page must be completed and returned to ensure receipt of future addenda or additional information. Fax this form to (907) 265-2439 or email to: [GoemerG@akrr.com](mailto:GoemerG@akrr.com). All addenda will be forwarded to the contact name and number listed below.

**Firms that have not returned the cover sheet will not be informed of addendums and will only be alerted to addendums by checking with the ARRC procurement officer or by checking ARRC's internet site: [www.akrr.com](http://www.akrr.com), select Suppliers and then Solicitations. Bidders must acknowledge the receipt of all issued addendums in their proposal/bid submittal.**

Company Name \_\_\_\_\_

Mailing Address \_\_\_\_\_

City, State, Zip \_\_\_\_\_

Contact Name \_\_\_\_\_

Phone Number \_\_\_\_\_ Fax \_\_\_\_\_

Email Address \_\_\_\_\_

The Alaska Railroad Corporation web site [www.alaskarailroad.com](http://www.alaskarailroad.com)

THIS IS NOT AN ORDER

INVITATION NUMBER: 19-37-207488  
DATE OF INVITATION: September 19, 2019

SEALED BIDS WILL BE RECEIVED AT:

Alaska Railroad Corporation  
327 West Ship Creek,  
Anchorage, Alaska 99501

UNTIL 3:00 P.M. LOCAL TIME ON **October 10, 2019**, AT THAT  
TIME BIDS WILL BE PUBLICLY OPENED.

### **ARRC Passenger Coach Painting and Repair ARR 200, and ARR 201**

The Alaska Railroad Corporation ("ARRC") is soliciting bids from interested parties to repaint and repair passenger coaches as specified herein. Interested parties are invited to submit a bid to supply said services to ARRC. Bids must be submitted on the bid form contained herein and must be mailed or delivered to the above address. Bids received via facsimile transmission will be considered non-responsive. The bid shall be in a sealed envelope with the bid number 19-37-207488 clearly printed on the face of the envelope. Bids must be complete and in U.S. dollars. See instructions and conditions enclosed herein.

ARRC reserves the right to reject any and all bids, or any part thereof, negotiate changes in bids, accept any bids or any part thereof, waive minor informalities or defects in any bids, and not to award the proposed contract if it is in the best interest of the ARRC.

ARRC shall not be held responsible for bidder's lack of understanding of what is required by this bid. Should a bidder not understand any aspect of this bid, or require further explanation, or clarification regarding the intent or requirements of this bid, it shall be the responsibility of the bidder to seek guidance from the ARRC.

ARRC may award a contract resulting from this solicitation to the responsive offeror whose offer conforming to this solicitation will be the most advantageous to the ARRC. ARRC may reject any or all offers if such action is in the best interest of ARRC, and waives informalities and minor irregularities in offers received. Any resulting contract from this solicitation shall incorporate the Standard Instructions, and General Terms and Conditions incorporated in this solicitation.

This solicitation is not to be construed as a commitment of any kind nor does it commit the ARRC to pay for any costs incurred in the submission of an offer or for any other incurred cost prior to the execution of a formal contract

**BIDDER/VENDOR TERMS AND CONDITIONS: PROSPECTIVE BIDDERS ARE CAUTIONED TO PAY PARTICULAR ATTENTION TO THIS CLAUSE.** Bidder/contractor imposed terms and conditions which conflict with this Invitation to Bid terms and conditions are considered counter offers and, as such, will cause the Alaska Railroad Corporation to consider the bid non-responsive.

If a bidder attaches additional terms and conditions as part of the bid, such attachments must be accompanied by a disclaimer stating that in the event of conflict between the terms and

conditions of this Invitation to Bid and the terms and conditions of the bidder/contractor, the terms and conditions of the Invitation to Bid will prevail.

**Important:** Work associated with this bid may be funded in part by funds from the Federal Transit Administration (“FTA”), an operating administration of the United States Department of Transportation; the Federal Railroad Administration (FRA); and the Alaska Railroad Corporation (ARRC). This solicitation package contains some provisions that are designated as applicable to FTA, FRA, and ARRC funded projects, mixed funding. See appendix H

ARRC Disadvantaged Business Enterprise (DBE) Program: ARRC is an equal opportunity corporation that encourages the participation of DBEs as prime contractors and subcontractors on its contracts funded in whole or in part by the Federal Transit Administration (FTA) or the Federal Highway Administration (FHWA). The ARRC has a race neutral DBE Program and does not set DBE goals on individual solicitations. Nonetheless, the ARRC aspires to achieve an overall DBE participation of 3.0% in federal fiscal years 2019-2021 on contracts funded by agencies within the U.S. Department of Transportation. If this contract is funded in whole or in part by funds from the FTA or the FHWA, it is imperative that you consult the Federal Terms and Conditions portion of this solicitation.



The Alaska Railroad is a member of Green Star (<http://www.greenstarinc.org/>). ARRC earned an initial Green Star Award in 1994 and a Green Star Air Quality Award in 2007. The Alaska Railroad considers Green Star membership to be a positive business attribute, and regards a Green Star award as a tangible sign of an organization’s commitment to environmental stewardship and continual improvement within its operations.

Please direct all responses and/or questions concerning this invitation to bid to Greg Goemer, Alaska Railroad Corporation, Supply Management, 327 W. Ship Creek Avenue, Anchorage, AK 99501, telephone number 907-265-2593, email address [goemerg@akrr.com](mailto:goemerg@akrr.com). Questions must be submitted in written form prior to October 7, 2019. Questions submitted after that date may not be accepted.

Sincerely,

Greg Goemer  
Sr. Contract Administrator

## INDEX

APPENDIX A	SCOPE OF WORK / MINIMUM QUALIFICATIONS
APPENDIX B	SPECIFICATIONS
APPENDIX C	PAINT SYTLING AND DETAILS AND VESTIBULE STAIRS
APPENDIX D	COST SCHEDULE
APPENDIX E	BIDDERS QUESTIONNAIRE
APPENDIX F	SUPPLY BID FORM
APPENDIX G	GENERAL TERMS AND CONDITIONS
APPENDIX H	FEDERAL TERMS AND CONDITIONS
ATTACHMENT A	PASSENGER COACH PAINT STYLING
ATTACHMENT B	VESTIBULE STAIRS

**SUBMITTALS:** Bids will not be considered if the following documents are not completely filled out and submitted at the time of bidding:

1. Supply Bid Form
2. Cost Schedule
3. Welding Qualifications
4. Bidder's Questionnaire
5. Federal Requirements: Appendix H:
  22. FTA BUY AMERICA REQUIREMENTS-49 USC §5323(j); 49 CFR Part 661
  25. CERTIFICATION REGARDING USE OF CONTRACT FUNDS FOR LOBBYING-31 USC 1352, 49 CFR Part 19, 20

## APPENDIX A

### SCOPE OF WORK / MINIMUM QUALIFICATIONS

#### Alaska Railroad 200 & 201 Passenger Coach Repair and Painting

##### Schedule:

ARR 200: The Contractor will have access to the car in Anchorage, AK on, or around, September 21<sup>st</sup>, 2019. The car must be returned to the ARRC Anchorage Car Shop NLT January 31<sup>st</sup>, 2020.

ARR 201: Barring the results of the assessment, the ARR 201 will be accessible to the Contractor once the ARR 200 has returned to revenue service. The car must be returned to the ARRC Anchorage Car Shop April 15<sup>th</sup>, 2020.

##### Estimated Hours for Repairs (per coach):

- Spot repair of the sheeting, doors and roof – **480 man hours**
- Repairs to vestibule, cross-over plates, installation of new supports for stairs, surrounding J-boxes, exposing collision posts – **410 man hours**
- Replacing end sheeting, four each – **110 man hours**

##### Tools and Materials:

Tools and materials necessary to accomplish repairs described above are the responsibility of the contractor with the exception of aluminum sheeting which Alaska Railroad will provide.

##### Scope:

Neither the manufacturer's drawings nor its specifications are available. Additionally if the aforementioned were available, the coach has been modified from its original construction and said modifications have also not been documented. The exterior structure of the car consists of aluminum sheeting over an aluminum and steel substructure.

As the coaches will be provided to the Contractor with the interiors intact, care must be taken to ensure that the interiors are not damaged or adversely affected throughout the duration of the work. All costs associated with the repair or replacement of any portion of the interior as either a direct or indirect result of the work performed under this Contract will be the Contractor's responsibility.

In preparation for paint, the Contractor shall remove all windows along with their associated gaskets, grab irons, exterior lighting (e.g. vestibule lighting), louvers, trim, and any other appurtenances that are not intended to be painted. All items removed from the exterior of the coach are to be stored and protected from damage until which time the Contractor re-installs said items. Special care is to be taken when handling the windows.

Exterior appurtenances that are scheduled to be removed are to be stripped and repainted as outlined herein. Said items shall be handled in the same manner as stated above until which time they are reinstalled on the coach.

Prior to the application of the exterior paint, the surface scheduled to be painted will be stripped of all coatings to include, but not limited to, body filler. Upon completion of the aforementioned task, notify the Owner so that the condition of the exterior may be inspected with, at a minimum, the Owner's representative present. As the intent of the inspection is to assess the condition of both the sheeting and the substructure to which it is attached, the Owner anticipates the removal of additional components (*i.e. components not required to be removed to refinish the exterior*) the assessment, most notably components adjacent to the side sills. Structural repairs that could affect the coach's service performance, collision loading, or crashworthiness are not anticipated to be performed. The roof of the coach will be inspected at this time as well. The Contractor will seam-seal all cracks that are identified at this time, or at any time during the duration of the work.

After the Owner, and/or its representative, have completed their assessment of the coach, an individualized general repair plan shall be prepared for the Contractor's use to address each failed, or damaged, item or member identified during the assessment. The Contractor is to submit to the Owner a phasing plan, schedule (*to include estimated man hours per task*), and a work plan (*to include means and methods, products, etc.*) outlining how it intends to complete the work. The aforementioned submittals are to be reviewed and approved by the Owner prior to commencing work.

#### **Anticipated Repair Work:**

During the removal of metal, or any other item, from the passenger coach, the Contractor will be responsible for all costs associated with the protection of both the interior and exterior surfaces of the coach. Furthermore, the Contractor is responsible for the repair of any such damages sustained to aforementioned while the coach is in their possession.

When the work dictates that installation of new sheeting, the Contractor will provide and install new tap plates, with a minimum width of four (4) inches, along the perimeter of the opening to allow the new sheeting to be fastened down to create a seamless transition between existing and replacement sheeting.

Body Work. As previously mentioned, during the stripping phase the Contractor is to remove all body filler materials to allow the coach's sheeting to be assessed. If exterior sheeting is found to be in disrepair or decayed, the ARRC shall provide a sufficient quantity of new 6061 aluminum sheeting for the Contractor to install per the Owner's direction. After the removal of any sheeting, the Owner and/or its representative shall inspect the underlying substructure for defects and/or damage. Upon completion of any required sheeting replacement, and after the satisfactory inspection of the entirety of the coach's sheeting; the Contractor is to prime the surface and then apply new body filler until a 'smooth' to 'smooth rolling' surface is achieved. When body filler is placed adjacent to seams, it shall be placed in a minimalistic manner to help mitigate cracking.

Window Frame Repair. After the removal of the windows, the area around the window shall be sand blasted and then inspected for damage and defects. Any material, or sheeting, found to be either decaying or in disrepair shall be replaced in-kind to the exact dimensions of the opening prior to implementing repairs. After the completion of all painting activities, the windows are to be reinstalled using new rubber gaskets that are to be provided by the Owner.

Side Sill Sheeting Repair. Prior to commencing repair work associated with the side sill, the coach must be immobilized via blocking of the trucks. Where it is scheduled to replace a large panel, support the side sill a minimum of every four (4) feet on center and a minimum of four (4) feet

beyond the extends of the limits of the panel to be replaced. The opposing side must be supported in a similar fashion to balance the coach and shall be placed in such a manner that minimizes the potential for damage to any part of the coach and for deflection while removing metal from the coach. Prior to the placement of jacks and/or supports on any portion of the car, submit a bracing plan to the Owner for review as the proposed locations must have sufficient strength to carry potential loads and mitigate the potential for differential deflection.

Once the side sill sheeting is open, the Contractor shall cut and remove all damaged and/or defective material, as needed, to replace the sheeting up-to the hours indicated above herein. Furthermore, the Contractor is to inspect and document the condition of the inner framing. Said framing shall be sand blasted to facilitate the inspection. Any aluminum or steel members found to be either in disrepair, decayed, or damaged will either be replaced and/or repaired, as required. Prior to affixing the new sheeting with stainless steel screws, all exposed inner framing is to be coated with DIMETCOTE® 302H Reinforced Inorganic Zinc Primer (or approved equal) in accordance with the manufacturer's recommendations and Appendix B.

End Sheeting Repair. End sheets consist of full sheets of material huck riveted to the substructure from the top of the sheet to within ≈24.0 inches of the bottom of the sheet. Contractor is to remove the end sheeting to expose the end-side sill member to a height not exceeding the side lower belt rail (*dependent on the extent of the sheeting damage or decay*) on each corner of the coach. Additionally, the removal of the end sheets need to extend to the collision posts so that they can be inspected by the Owner or its representative. Sheeting is not to be reinstalled until any repairs stemming from the inspection of the collision posts have been satisfactorily completed and the flooring (indicated below) has been installed. If required, the Contractor is to fabricate and install new hangers for installation of the salvaged gate.

Contractor shall inspect both the entry doors and their surround jams for damage, decay, and defects. Provide the Owner with the inspection report and the Contractor's recommendation for remediation of the items identified in said report (*e.g. door replacement, door patching, and general repairs*). Any such repairs are to be completed prior to painting the exterior of the coach.

Remove any appurtenances from the ceiling or walls that is scheduled to be remove, such as abandoned DC junction boxes, light fixtures, speakers, etc. Wiring found in the aforementioned shall be twisted together with a wire nut (or wire nuts), taped with electrical tape, and pushed into the wall, and then cover the opening with a sufficiently sized cover cap.

A - End Repairs. Remove the existing cross-over diaphragm floor plate and replace in-kind with 1/8" thick stainless tread plate. Contractor is to inspect the underlying structure for any damage or defects prior to affixing the new flooring materials. Notify the Owner, or its representative, as soon as practicable if damage or defects are found. After the Owner, or its representative, have inspected and assessed the extent of the damage or defect; the Contractor will be directed on how it's to be repaired.

B - End (Vestibule) Coach Repairs. Inspect the sheeting surrounding the remainder of the vestibule for damage, decay, and defects. Notify the Owner, or its representative, as soon as practicable if damage or defects are found. After the Owner, or its representative, have inspected and assessed the extent of the damage or defect; the Contractor will be directed on how it's to be repaired. Sheeting that is beyond repair will be removed and replaced in accordance with the specifications stated herein.

Remove and salvage the right and left drop down stair assemblies, their mounting hardware, and the sheeting shrouding the assembly for the Owner's re-use. Fabricate and install new stair assemblies, along with the require mounting components, per the attached Plan set. Contractor is to submit shop drawings for review, and approval, prior to the fabrication of the stair assemblies and their associated mounting components. The shroud that covers the exposed side of the stair assembly shall be replaced with 3/16 inch stainless steel plate that is affixed to the stair assembly using stainless steel hex drive button head cap screws.

Inspect the trap door assemblies, the upper and lower bi-fold doors, and their mounting assemblies, for damage, decay, and defects. Provide the Owner with the inspection report and the Contractor's recommendation for remediation of the items identified in said report (*e.g. trap door replacement, door patching, and general repairs*). Any such repairs are to be completed prior to painting the exterior of the coach.

The existing floor plate is to be removed and replace in-kind with 1/8" thick stainless tread plate. Contractor is to inspect the underlying structure for any damage or defects prior to affixing the new flooring materials. Notify the Owner, or its representative, as soon as practicable if damage or defects are found. After the Owner, or its representative, have inspected and assessed the extent of the damage or defect; the Contractor will be directed on how it's to be repaired.

Once the end sections are open, the Contractor shall cut and remove all damaged and/or defective material, as needed, to replace the sheeting up-to the hours indicated above herein. Furthermore, the Contractor is to inspect and document the condition of the inner framing. Said framing shall be sand blasted to facilitate the inspection. Any aluminum or steel members found to be either in disrepair, decayed, or damaged will either be replaced and/or repaired, as required. Prior to affixing the new sheeting with huck rivets, all exposed inner framing is to be coated with DIMETCOTE® 302H Reinforced Inorganic Zinc Primer (*or approved equal*) in accordance with the manufacturer's recommendations and Appendix B.

*Paint.* Once the Owner and/or its representative have accepted the repair work outlined herein, the coach is to be painted in accordance with Appendix B – "*Specifications for Repainting of Passenger Cars and Locomotive Exteriors*" and all applicable industry standards that apply to the task at hand. Deviation from the attached plan set is not acceptable, any deviation from said plan shall be rectified by the Contractor at no cost to the Owner.

**Minimum Qualifications:** The prospective Contractor will have its own rail accessible shop in which to perform all of the work required within this solicitation. Its paint and repair facility shall meet all Local, Federal, State and Tribal regulations/requirements for work of this nature.

As the ARRC image is perceived by the public on its blue and gold rolling stock, the prospective Contractor shall have a minimum of five (5) years' experience in the painting, body work, and repair of heavy equipment. Although not required, experience painting railcars or locomotives is preferred.

The minimum qualifications stated herein must be fulfilled by the prospective Contractor and may not be satisfied by use of a sub-contractor.



**Owner Repairs:** As certain repairs to ARRC's rolling stock may only be performed by its trained individuals, the Contractor is required to provide the ARRC's employees access to its shop. ARRC employees shall be allowed to perform their prescribed work within the confines of the Contractor's shop.

**Welding Requirements - Steel:** Welding methods are restricted to shielded metal arc welding (SMAW), gas metal arc welding (GMAW), or flux core arc welding (FCAW). FCAW with dual shield is the preferred method. Approved weld types include, but are not limited to: groove welds, fillet welds (*flat, slightly concave, and slightly convex weld profiles are acceptable*), plug welds, slot welds, and butt welds. The method of depositing metal shall be chosen to minimize warpage to the metals which are both being welded to and upon.

All welders performing work in under this Contract will only perform pre-qualified and approved welds, in the locations indicated, and shall be qualified to perform said welds in accordance with industry standards pertaining to the task at hand. Submit all weld procedures that are intended to be utilized under this Contract as well as each welder's qualification(s).

Welding activities shall be restricted to enclosed areas (*sheltered from inclement weather and moisture*) where the ambient temperature is not less than 50° Fahrenheit. Equipment of sufficient size, and of appropriate age, will be used to perform the welds and/or cuts, in accordance with the pre-qualified weld procedure that is being utilized, to allow qualified welders to furnish sound structural welds.

**Weld Repairs:**

**Discontinuities Repair.** The amount of metal removed shall be the minimum necessary to remove the discontinuity. The removal of weld material, or any portion of the base metal required to be removed, shall only be performed by means of machining, grinding, chipping, oxygen gouging, air arc, or plasma arc gouging. The unacceptable portion of the weld, is to be removed without substantial removal of the base metal, as much as practicable.

In the event that a repair to a weld is required, the Contractor has the option of either repairing said weld in accordance with industry standards or removing and replacing the entire weld at no cost to the Owner.

**Distortion Control - Steel.** When and where required, steel members distorted by welding shall be straightened by mechanical means or by the carefully supervised application of a limited amount of localized heating. Prior to performing straightening of any warped members, provide details to the Owner and/or its representative so that it may evaluate whether or not it is acceptable to do so. Any metal warped beyond an acceptable tolerance, as a result of the Contractor's mean and methods, will be replaced by the Contractor at no additional cost to the Owner.

**Arc Strikes.** Arc strikes that occur outside the area of the permanent weld(s) should be avoided at all costs on any base metal. Cracks or blemishes caused by arc strikes shall be ground to a smooth contour and inspected to ensure soundness prior to repair. Provide details of any repair, to include method of repair and extent of damage, to the Owner prior to performing any repairs.

**Cleaning of Single Pass and Multi Pass Welds.** Before welding over previously deposited metal, all slag shall be removed from both the weld and the adjacent base metal shall be clean. This requirement shall apply not only to successive layers of weldment, but also to successive beads and to the crater area when welding is resumed after any interruption.

Weld Appearance. Weld splatter adhesions shall be removed by sanding or grinding, as required.

Weld Termination. Welds shall be terminated at the end of a joint in a manner that will ensure welds are sound and in accordance with the weld procedure being performed.

**End of Section**

**APPENDIX B  
SPECIFICATIONS**

**SPECIFICATION FOR THE REPAINTING OF  
PASSENGER CAR AND LOCOMOTIVE EXTERIORS**

Revision No. 4, June 2016

<b>SECTION</b>	<b>PAGE</b>
GENERAL	1
Scope	1
Reference Documents	1
MATERIALS	3
Abrasives	3
Coatings and Thinners	4
Colors	5
Caulks, Sealants and Body Fillers	6
EXECUTION	6
Workmanship	6
Surface Preparation	6
Seams, Uneven Surfaces	8
Application	8
Color Scheme	10
QUALITY CONTROL – CONTRATOR	11
UNACCEPTABLE DEFECTS	12
COMPLETION	12
WARRANTEE	12
TABLES	14
Table 1 – Coatings and thinners for the Exterior Surfaces of Rail Cars.	14
Table 2 – Caulks, Sealants and Body Fillers for the Exterior Surfaces of Rail Cars	15
Table 3 – Surface Preparation and Maintenance Painting Guidance for the Exterior Surfaces of Rail Cars.	16
Table 4 – Surface Preparation and Maintenance Painting Guidance for the Exterior HVAC Wells and Roofs	17

## 1.0 GENERAL

- 1.1 Scope:** This specification covers the surface preparation and coating application requirements for performing maintenance painting on the exterior of railroad passenger cars and locomotives for Alaska Railroad Corporation (ARRC). In this context, exterior refers to the sides, roof, ends, vestibule interior(s) and underframe equipment. Substrates include existing intact and adherent coating, high strength low alloy carbon steel, aluminum and durable epoxy body filler. Maintenance painting may include any of the following strategies: spot repairs, spot repairs and over coating, zone repairs and full removal and replacement.

Surface preparation shall include methods for spot repairs, spot repairs and overcoating, zone repairs and full removal and replacement of existing coating systems.

Power Washing, LPWC	SSPC-SP WJ-4/NACE WJ-4
Solvent Cleaning	SSPC-SP 1
Hand and Power Tool Cleaning	SSPC-SP 2, SSPC-SP 3, SSPC-SP 15, SSPC, SP 11
Abrasive Blast Cleaning	SSPC- SP 7/NACE No. 4, SSPC-SP 6/NACE No. 3, SSPC-SP 16
Aluminum Preparation	ASTM D1730

Coating application methods include brush, roller, dauber, conventional spray, HVLP (high volume low pressure) spray, airless spray and plural component airless spray for polyurea application.

- 1.2 Reference Documents:** The following is a listing of the publications referenced in this section of the Technical Specifications. Unless otherwise noted, the latest revision of the standards in effect at the time of bid shall apply. The absence of a reference otherwise identified does not negate the requirements or information therein.

### American Society for Testing Materials

ASTM D1730 09	Standard Practices for Preparation of Aluminum and Aluminum-Alloy Surfaces for Painting
ASTM D 3359	Standard Test Methods for Measuring Adhesion by Tape Test

ASTM D 4138	Standard Test Methods for Measurement of Dry Paint Thickness of Protective Coating Systems by Destructive Means
ASTM D 4285	Standard Test Method for Indicating Oil or Water in Compressed Air
ASTM D 4414	Standard Practice for Measurement of Wet Film Thickness by Notch Gages
ASTM D 4417	Standard Test Methods for Field Measurement of Surface Profile of Blast Cleaned Steel. Method C
ASTM D 4541	Standard Test Method for Pull-Off Strength of Coatings Using Portable Adhesion Testers
ASTM D4752	Standard Test Method for Measuring MEK Resistance of Ethyl Silicate (Inorganic) Zinc-Rich Primers by Solvent Rub”
ASTM D 6386	Standard Practice for Preparation of Zinc (Hot-Dip Galvanized) Coated Iron and Steel Product and Hardware Surfaces for Painting
ASTM D 7091	Standard Practice for Nondestructive Measurement of Dry Film Thickness of Nonmagnetic Coatings Applied to Ferrous Metals and Nonmagnetic, Nonconductive Coatings Applied to Non-Ferrous Metals

**SSPC: The Society for Protective Coatings (SSPC)**

SSPC-SP 1	Solvent Cleaning
SSPC-SP 2	Hand Tool Cleaning
SSPC-SP 3	Power Tool Cleaning
SSPC-SP 15	Commercial Grade Power Tool Cleaning
SSPC- SP 7/ NACE No. 4	Brush-Off Blast Cleaning
SSPC-SP 6/ NACE No. 3	Commercial Blast Cleaning
SSPC-SP WJ-4/NACE WJ-4	Waterjet Cleaning of Metals WJ-4 – Light Cleaning

SSPC-SP 16	Brush-Off Blast Cleaning of Coated and Uncoated Galvanized Steel, Stainless Steels, and Non-Ferrous Metals
SSPC-VIS 1	Visual Standard for Abrasive Blast Cleaned Steel
SSPC-VIS 3	Visual Standard for Hand and Power Tool Cleaned Steel

**Equipment and Coating Manufacturer Published Instructions  
Code of Federal Regulations (CFR)**

29 CFR 1910, Occupational Safety and Health Regulations for General Industry

29 CFR 1926, Occupational Safety and Health Regulations for the Construction Industry

40 FR 261-268, Resource Conservation and Recovery Act (RCRA)

**2.0 MATERIALS:** All supplied materials shall be finest quality, suitable for the intended purpose and supplied in original unopened containers. Provide Manufacturer's Warranties for coating performance including blisters and adhesion to properly prepared surfaces. All finish coating products shall also be supplied with the Manufacturer's Warranty for gloss and color retention. Provide manufacture technical data sheets and material safety data sheets for all materials supplied and incorporated into the work.

**2.1 Abrasives:** Supply abrasives meeting the requirements of SSPC-AB 1 (Mineral and Slag Abrasives) and/or SSPC-AB 4 (Recyclable Encapsulated Abrasive Media). In no case shall steel or iron abrasives be used on stainless steel, aluminum or galvanized surfaces.

**2.1.1** Mineral abrasives shall be Type 1<sup>1</sup>, Grade 1<sup>2</sup> Class A<sup>3</sup> mineral abrasives per SSPC-AB 1 that will remove existing coating, rust, and scale from substrates to be prepared by abrasive blast cleaning. Abrasives shall be free of oil and meet the water soluble contaminant requirements of Section 4.1.4. When recyclable abrasives are used verify the cleaned recycled abrasive meets the requirements of 4.4 Quality Control Tests for Recycled Work Mix.

**2.1.2** Encapsulated abrasive (e.g. Spongjet) shall contain mineral abrasives meeting the requirements of 2.1.1. and produce an anchor profile of 0.5 to 1.5 mils. Recycled and cleaned encapsulated abrasive media shall conform

---

<sup>1</sup> Natural mineral Abrasives

<sup>2</sup> Abrasives that produce surface profiles of 1.5 to 2.5 mils (38 to 64 micrometers [µm]) when tested in accordance with Section 4.1.8.

<sup>3</sup> Containing no more than 1.0% free silica

to the requirements of SSPC-AB 4 Sections 6.2.1.2 Test for Classifier Efficiency, 6.2.2 Water-Soluble Contaminants and 6.2.3 Oil Content.

**2.2 Coatings and Thinners:** Provide paints, coatings, thinners in original unopened containers. Products or product components that have exceeded their shelf life before the date of application shall not be used. Use only thinners recommended by the coating manufacturer. The coating products listed herein are representative of the type and quality required for application. All coatings shall be provided by the same manufacturer<sup>4</sup>. Table 1 provides alternate systems by PPG Industries and Sherwin-Williams.

**2.2.1 Substitutions** - Materials specified are those which have been evaluated for the specific service. Products are listed to establish a standard of quality. ARRC approved equal(s) for each product may be substituted. Submit requests for material substitution no later than two weeks<sup>5</sup> prior to date of surface preparation. No substitution of materials is allowed without ARRC written approval. All coatings shall be provided by the same manufacturer<sup>4</sup>. Products of manufacturers other than those specified or approved by ARRC will be accepted when proven to the satisfaction of the County they are equal in composition, durability, usefulness and convenience for the purpose intended. Substitutions will be considered provided the following minimum conditions are met:

The proposed coating or paint system shall have a dry film thickness (DFT) equal to or greater than that of the specified system.

The proposed coating or paint system shall employ an equal or greater number of separate coats.

The proposed coating or paint system shall employ coatings or paints of the same generic type.

All requests for substitution shall carry full descriptive literature and directions for application, along with complete information on generic type, non-volatile content by volume and a list of 10 similar projects, all at least three years old, where the coatings or paints have been applied to a similar exposure.

If the above mentioned data appears to be in order, ARRC may require that the Contractor provide certified laboratory data sheets showing the results of complete spectrographic and durability tests accomplished on the proposed

---

<sup>4</sup> Should use of materials from different manufacturers be requested include a letter from at least one of the manufacturers that states it will warranty against all compatibility related failures.

<sup>5</sup> material availability may require a different lead time

substitute. An independent testing laboratory satisfactory to ARRC shall accomplish tests and all costs incurred in the testing program shall be borne by the Contractor. In any case, ARRC shall be sole and final judge of the acceptability of any proposed substitution. Requests for substitution must be approved in writing.

- 2.2.2** Primer: Primer coats may include wash primers for aluminum, galvanized and stainless substrates, epoxy primer for steel surfaces or penetrating sealers to serve as tie- coats for application over existing coatings.

Dupont WP™ Chrome-Free Wash/Etching Pre-Treatment Primer

Corlar® 2.1-St™ Satin High Solids Epoxy Mastic

Imron® Industrial Strength Low VOC Polyurethane Primer

DuPont™ Epoxy DTM Primer/Sealer 2510S/2540S/2570S/2580CR under filler

- 2.2.3** Intermediate Coat: Intermediate coats may include epoxy, polyurethane or moisture cure polyurethane to provide barrier protection and film build.

Corlar® 2.1-St™ Satin High Solids Epoxy Mastic

- 2.2.4** Finish Coat: The finish coat shall be a two component polyurethane product with excellent color retention weather resistance. Fluoropolymer coatings based on urethane chemistry may be submitted for review. Provide finish coating products in the colors required for the work. See Section 2.3 and Section 4.0 of this specification.

Imron® 3.5 HG™ +Polyurethane High Gloss Topcoat

Clear Coat- The clear coat shall be two-component polyurethane compatible with the finish coat

Imron® 3.5 HG-C™ High Gloss Clear Polyurethane

- 2.3 Colors:** Provide finish coats to match the following color designations even if the coating supplier is not the manufacturer identified.

Aluminum: Seymour of Sycamore, Inc. #620-1411  
Sherwin Williams B59S11



Other Colors:

Exterior Dupont Imron 5000 (numbers for Imron 3.5HG):

Yellow: 54701  
Blue: 63203  
Black: 24926  
Silver: see Aluminum  
Clear Coat: Imron 3.5HG-C clear

Interior Dulux Color Numbers:

Beige: LFQ4G34P (locomotive cabs and short hoods)  
Grey: LF25W34P (locomotive engine rooms)

- 2.4 Caulks, Sealants and Body Fillers:** Provide paintable caulks and sealants recommended by the coating manufacturer. Use high solids epoxy body putty suitable for repair of dents, buckles and depressions in the car bodies. Table 2 provides alternate products for use with PPG Industries systems.

Suitable products include:

DuPont™ Premier Filler™ LE 3401S™/LE 3404S™/ LE 3407S™ Urethane Primer Filler

DuPont Premium Lightweight Body Filler 313

3M™ Quick Grip Filler /3M™ Short Strand Fiberglass Reinforced Filler

### **3.0 EXECUTION**

- 3.1 Workmanship:** The performance of all work will be in accordance with industry standards, best practices and applicable state local and federal safety and environmental rules and regulations. Public image is very important to ARRC and the major purpose in undertaking this work is to promote that image including appearance and stewardship.

#### **3.2 Surface Preparation**

**NOTE:** The contractor is hereby advised that many passenger cars still in service were built long before lead-based paints went out of favor and it is most likely that such paint will be found on them.

- 3.2.1** Surfaces shall be prepared in accordance with paint manufacturer's requirements and recommendations to the extent that they exceed this

specification. The contractor shall bring to the attention of ARRC's project manager for resolution any conflict between these specifications and the manufacturer's published data. Tables 3 and 4 provides summary directions for surface preparation based on the substrate and maintenance painting requirements. Do not conduct final surface preparation unless the substrate temperature is a minimum of 5°F above the dew point. Provide clean dry compressed air for all operations where air may be used for surface preparation, surface blow-down, and coating application.

**3.2.2** Cleaning- Prior to beginning surface preparation power wash and solvent clean (SSPC-SP 1) all surfaces to be prepared and coated. Use cleaning aids acceptable to the Engineer as necessary to remove soot, soils, sap, and surface dirt. Do not conduct surface preparation unless the substrate temperature is a minimum of 5°F above the dew point.

**3.2.3** Spot Repairs- All areas of rust, corrosion, defective paint, cracked, lifting, deformed or otherwise defective caulks, sealers and fillers and oxidation shall be removed Exposed bare metal shall be solvent cleaned and prepared by abrasive blast cleaning (SSPC-SP 6) or may be prepared using power tool cleaning (SSPC-SP 11 or SSPC-SP 15). Produce an anchor profile of 1.5 to 2.0 mils as measured in accordance with ASTM D4417 Method C. Any defects on passenger cars requiring more than 1/8" of filler shall be brought to the attention of ARRC and work held pending a decision as to best method for repair.

Prepare existing adherent existing coating that will remain around the spot repair by sanding using hand or power tools (SSPC-SP 2 or SSPC-SP 3). Feather the edges of the coating around all spot repairs a minimum of 2 inches onto the existing coating and provide a smooth transition for the coating to be applied. Note that removed caulks, sealants and fillers will be replaced in kind. 3.2.3.

**3.2.4** Spot Repairs and Overcoating- Perform spot repairs as required in Section 3.2.2. Adherent paint that will remain and be overcoated shall be etched or sanded in accordance with SSPC-SP 3 or SSPC-SP 7 for Steel and SSPC-SP 3 or SSPC-SP 16 for Aluminum and/or Stainless Steel.

**3.2.5** Removal and Replacement- Complete or zone removal<sup>6</sup> of the existing coatings shall be performed by abrasive blast cleaning in accordance with SSPC-SP 6. Provide an anchor profile of 1.5 to 2.0 mils as measured in accordance with ASTM D4417 Method C. Conduct the cleaning with care

---

<sup>6</sup> Zone removal refers to large surface areas that require removal and replacement but not to the extent that the entire car requires maintenance painting. For example, the work may be limited to trucks or roofs.

when moving from steel to aluminum or stainless steel surfaces to avoid excess damage and unacceptable anchor profiles.

- 3.2.6** Use of Abrasives- Whenever abrasive blasting is performed; protect all surfaces not to be painted from damage and contamination by abrasives. This shall include air intakes, vents, bright metal, glass, gaskets, machined surfaces and mechanical and electrical equipment. All dust, abrasives and other interference materials shall be removed before priming.
- 3.2.7** Cleanliness-Verify the degree of cleanliness meets the applicable surface preparation criteria. Use SSPC-Vis 1 as an aid in evaluating surfaces prepared by abrasive blast cleaning. Use SSPC-Vis 3 as an aid in evaluating surfaces prepared by hand and power tool cleaning.

### **3.3 Seams and Uneven Surfaces**

All seams and uneven surfaces, dents (depressions) in surface shall be roughened, feathered out primed and filled with compatible body filler suitable for temperature extremes of -60 to +100 F. Some patch work may need to be continuous from seam to seam, to prevent an undesirable finish variation. Old lettering (unless it is to be reapplied) shall be sanded out or filled so as to be illegible after application of the primer coat.

- 3.3.1** In preparation for painting, girder sheets shall be repaired and any loose side sheeting re-secured using fastening techniques standard to the car ' s original construction.
- 3.3.2** Holes, large dents, tears and corroded areas shall be patched (by welding with applicable type of stainless steel, aluminum or steel rod). Small dents (up to 1/8" deep) shall be filled using an epoxy or polyurethane body filler. Patch all damaged areas. Priming of mild carbon steel and non-ferrous metals shall be done before occurrence of any corrosion (detectable by eye or touch). Total film thickness of primer shall be 5 to 6 mils (wet) applied in one coat.

### **3.4 Application**

- 3.4.1** All materials shall be applied and allowed to cure in strict accordance with manufacturer ' s requirements and recommendations. All applications and curing shall be done in a warm, dry and dust free atmosphere.

Ambient Conditions - Apply coatings under the following conditions unless the requirements of the coating manufacturer are more restrictive. .

Surface and Air Temperatures - Between 50°F and 110°F.

Relative Humidity - Less than 85%.

Dew Point - Surface temperature at least 5°F above the dew point temperature of the surrounding air.

Frost/Rain - Do not apply coatings to surfaces containing frost or during rain, fog, or similar conditions.

Remove and replace any paint that is exposed to unacceptable conditions (e.g. rain or dew) prior to adequate curing.

It is the responsibility of the contractor to assure that the old finish is compatible with the new materials for spot repairs and overcoating. Any rework necessary due to reaction between the two materials shall be performed at no charge to ARRC.

**3.4.2** Pre-treat prepared bare aluminum surfaces with Dupont WP™ Chrome-Free Wash/Etching Pre-Treatment Primer

Primer	Urethane	DFT	3-5
--------	----------	-----	-----

Primer	Epoxy Mastic	DFT	5-8
--------	--------------	-----	-----

**3.4.3** Primer shall be applied immediately after completion of surface preparation. In the case of bare metal, it shall be completed before the formation of any oxides.

**3.4.4** Total film thickness of primer shall be 5 to 6 mils.

**3.4.5** Finish coat and lettering

**3.4.6** Finish coats shall be applied well within the time limits after immediately prior coat as specified by the paint manufacturer.

**3.4.7** Application shall consist of two coats totaling 1.5 to 2 mils DFT.

**3.4.8** Lettering shall be applied as shown on the detailed diagram.

**3.4.9** Required lettering and logos will be painted on and cleared over.

**3.4.10** Edges of all logos and any other decals or Scotch-Lite shall be sealed with a coat of clear lacquer prior to final (clear) coat.

**3.4.11** Final Coat: After all painting and lettering is complete the entire car body shall be given one coat of Dupont Imron 3.5 HG-C™ clear-coat within the recoat window of the pigmented finish coats. The finished product shall present a high gloss "wet" appearance.

## 4.0 Color Scheme

Paint scheme shall be as described on the specific painting diagram for the particular piece of equipment involved. The basic color scheme is described here for information only:

### 4.1 Aluminum, HSLA steel and flat panel Budd built ("smooth side") passenger cars:

#### **Car body:**

Blue with two yellow strips (on sides only, corner post to corner post):

On girder sheet: 21<sup>7</sup>/<sub>8</sub> " wide from 57 <sup>1</sup>/<sub>4</sub> " to 79 <sup>1</sup>/<sub>8</sub>" Above Top of Rail (ATR).

On letter board: 3 <sup>7</sup>/<sub>8</sub>" wide from 131 <sup>7</sup>/<sub>8</sub>" to 135 <sup>3</sup>/<sub>4</sub> " ATR.

**Roof:** Blue

#### **Lettering:**

Blue, on 21 <sup>7</sup>/<sub>8</sub>" yellow stripe as follows:

"ALASKA" in 9 <sup>1</sup>/<sub>4</sub>" (nominal) stylized font at left end of stripe (BR and AL), centered over truck.

**Road number** In 8" (nominal) stylized font, right end of strip (BR and AL), centered over truck.

**Alaska Railroad** logotype, 24" roundel, (yellow letters with open background allowing 63203 Blue to show), located at right end of each side (BL and AR) centered vertically on blue and horizontally 30" to the right of the visual end of the area (corner post or door post) if space permits, but not less than 21". (Omit where space is insufficient.)

**4.2 Underframe equipment:** Black. Protect all tags, nameplates and stainless steel. Do not paint these items.

**4.3 Trucks:** Silver (aluminum color enamel per 2.3 applied without primer)

**4.4 Fluted Stainless** steel passenger cars shall be unpainted except as follows:

**Striping:** A blue stripe shall run the full length of the letter board

**Lettering:** "ALASKA" in extended yellow stylized font visually centered<sup>7</sup> on the letter board. Name or road number in yellow stylized font on a blue background

**Logotype, underframe equipment and trucks:** same as smooth side cars

## 5.0 QUALITY CONTROL

**5.1 Contractor** - The Contractor shall be held in strict accordance with the requirements and intent of the Specifications.

**5.1.1** The Contractor shall perform and document Quality Control inspections and testing specified herein on all phases of surface preparation and coating application throughout the duration of the contract. Procedures or practices not specifically defined herein may be used provided they meet recognized and acceptable professional standards and are approved by ARRC.

Ambient Conditions – Sling Psychrometer, Electronic Gages

Cleanliness of compressed air supplies- ASTM D4285 at least once per shift

Degree of Cleanliness – As defined in the appropriate preparation standard aided by use of SSPC-Vis 1 and SSPC-Vis 3

Anchor Profile - ASTM D4417 Method C

Coating Mixing and Thinning - Products and thinner batch numbers

Include induction time and Potlife as appropriate.

Coating Wet Film Thickness (WFT) - ASTM D4414

Coating Dry Film Thickness (DFT) - SSPC-PA 2, Level 3 Criteria

**5.1.2** All materials furnished and all work accomplished under the Contract shall be subject to Quality Assurance (QA) inspections by ARRC at its discretion. The Contractor shall provide access and allow for adequate time to perform all inspections. ARRC will pay the cost of its own inspection.

**5.1.3** Work accomplished in the absence of prescribed inspections and may be required to be removed and replaced under the proper inspection. The entire cost of removal and replacement, including the cost of all materials used in the work thus removed, shall be borne by the Contractor regardless of whether the work removed is found to be defective or not.

---

<sup>7</sup> On dome cars "visually centered" means centered on the dome.

**6.0 UNACCEPTABLE DEFECTS:** Unacceptable defects in the applied coating system shall be corrected at no cost to ARRC. Unacceptable defects include deficiencies in surface preparation or coating application that are:

**6.1** Detectable by touch or unaided eye at any distance such as:

Off spray or dry spray (rough, sandy finish)

Bubbles, blistering, cracked, lifting or peeling coating

Over-spray or any paint on bright metal, glass and surfaces not scheduled for painting

**6.2** Visible from a distance of three feet or more in any lighting condition as determined by ARRC: These include:

Sags, curtains, runs or wrinkles

Air bubbles, pin holes, craters, fish eyes or other poor wetting

Blushing, color bleeding

Fuzzy color separation

Orange peel finish visible from a distance of 10 feet or greater

## **7.0 COMPLETION**

**7.1** All masking shall be removed and touch-up work complete before equipment is released or shipped to ARRC.

**7.2** ARRC reserves the right to perform a final inspection before shipping is permitted.

**8.0 WARRANTEE:** The contractor shall warrantee the finish against defects in materials and workmanship for two years of normal service anywhere on the Alaska Railroad.

**8.1** The Contractor warrantee shall include the adhesion of paint including bubbles, blisters, cracking, delamination, peeling and flaking between coats or between the underlying substrates and coating materials. If any repairs become necessary, the contractor shall perform the work at a time and place convenient to ARRC. ARRC shall make every effort to release the equipment to the contractor at a time and place convenient to the contractor, but actual performance will of necessity be constrained by operational considerations.

**8.2** The coating manufacturer shall provide a ten year warranty against color or gloss change of the finish coat and clear coats following its inspection of the [completed] work.

**Table 1 – Coatings and Thinners for the Exterior Surfaces of Rail Cars.**

Coat	Manufacturer Product Recommendations		
	DuPont	PPG	SW
Primer	Dupont WPT™ Chrome-Free Wash/Etching Pre-Treatment Primer	PPG Delfleet F4940 3.5 VOC Wash Primer <b>See note 1.</b>	E2G970 Chrome Free Wash Primer
	Corlar® 2.1-St™ Satin High Solids Epoxy Mastic	PPG Amercoat AT 370 Epoxy Primer	NP75 Epoxy Primer
	Imron® Industrial Strength Low VOC Polyurethane Primer	-	E2A819 Urethane Primer
	DuPont™ Epoxy DTM Primer/Sealer 2510S/2540S/2570S/2580CR <b>(for under filler)</b>	-	E2A960 Epoxy Sealer
Intermediate	Corlar® 2.1-St™ Satin High Solids Epoxy Mastic	PPG Amercoat 370 Epoxy Primer	NP75 Epoxy Primer
Finish	Imron® 3.5 HG™ +Polyurethane High Gloss Topcoat	PPG Amercoat 450H Polyurethane <b>See Note 2.</b>	Genesis® 3.5 Urethane Topcoat)
	-	PPG AUE 360 Polyurethane <b>See Note 3.</b>	-
Clear Coat	Imron® 3.5 HG-C™ High Gloss Clear Polyurethane	PPG AUE40 Industrial Clear	CC950 Clear coat

**Note 1-** Use only under Urethane Primers on Aluminum

**Note 2-** This product is recommended to be used without a clear coat.

**Note 3-** This finish coat product can be clear coated with PPG AUE40 Industrial Clear



**Table 2 – Caulks, Sealants and Body Fillers for the Exterior Surfaces of Rail Cars.**

<b>Caulks, Sealants and Body Fillers</b>	<b>DuPont</b>	<b>PPG</b>	<b>SW</b>
	DuPont™ Premier Filler™ LE 3401S™/LE 3404S™/ LE 3407S™ Urethane Primer Filler	PPG Delfleet F 3975 Urethane Surfacer	Request Recommendations
	DuPont Premium Lightweight Body Filler 313	Recommendation- Evercoat Quantum Filler	-

**Table 3 – Surface Preparation and Maintenance Painting Guidance for the Exterior Surfaces of Rail Cars.**

<b>Exterior Railcar Substrate</b>	<b>Maintenance Painting</b>	<b>Surface Preparation</b>	<b>Bare Metal Treatment</b>	<b>Primer</b>	<b>Finish</b>	<b>Clear Coat</b>
<b>Aluminum</b>	Spot	SP 2, SP 3, SP 15, SP 16	Wash Primer	Epoxy	Polyurethane	Polyurethane
	Zone	SP 2, SP 3, SP 15, SP 6	Wash Primer	Epoxy	Polyurethane	Polyurethane
	Overcoat	SP 2, SP3, SP 16	Wash Primer	Epoxy	Polyurethane	Polyurethane
	Replace	SP 6	Wash Primer	Epoxy	Polyurethane	Polyurethane
<b>Steel</b>	Spot	SP 2, SP 3, SP 15, SP 16	Epoxy	Epoxy	Polyurethane	Polyurethane
	Zone	SP 2, SP 3, SP 15, SP 6	Epoxy	Epoxy	Polyurethane	Polyurethane
	Overcoat	SP 2, SP3	Epoxy	Epoxy	Polyurethane	Polyurethane
	Replace	SP 6	Epoxy	Epoxy	Polyurethane	Polyurethane
<b>Stainless Steel</b>	Spot	SP 2, SP 3, SP 15, SP 16	Wash Primer	Epoxy	Polyurethane	Polyurethane
	Zone	SP 2, SP 3, SP 15, SP 6	Wash Primer	Epoxy	Polyurethane	Polyurethane
	Overcoat	SP 2, SP3, SP 16	Wash Primer	Epoxy	Polyurethane	Polyurethane
	Replace	SP 6	Wash Primer	Epoxy	Polyurethane	Polyurethane

**Table 4 – Surface Preparation and Maintenance Painting Guidance for the Exterior HVAC Wells and Roofs.**

<b>Exterior</b>	<b>Maintenance Painting</b>	<b>Surface Preparation<sup>1</sup></b>	<b>Bare Metal Treatment</b>	<b>Primer</b>	<b>Finish<sup>2</sup></b>	<b>Clear Coat</b>
<b>Railcar Roof</b>	Spot	SP 2, SP 3, SP 15, SP 16	Immersion Grade Epoxy	Recommended Epoxy Primer	Polyurea	N/A
	Zone	SP 2, SP 3, SP 15, SP 6	Immersion Grade Epoxy	Recommended Epoxy Primer	Polyurea	N/A
	Replace	SP 6	Immersion Grade Epoxy	Recommended Epoxy Primer	Polyurea	N/A

1. Polyurea does not lend itself to overcoating.
2. Polyurea shall be used to line HVAC wells to achieve a water tight seal from standing water. Other roof top surfaces may be coated with the systems identified for the metal substrate of the roof.

---

**APPENDIX C**

PAINT SYTLING ELEVATION AND DETAILS  
(SEE ATTACHED)

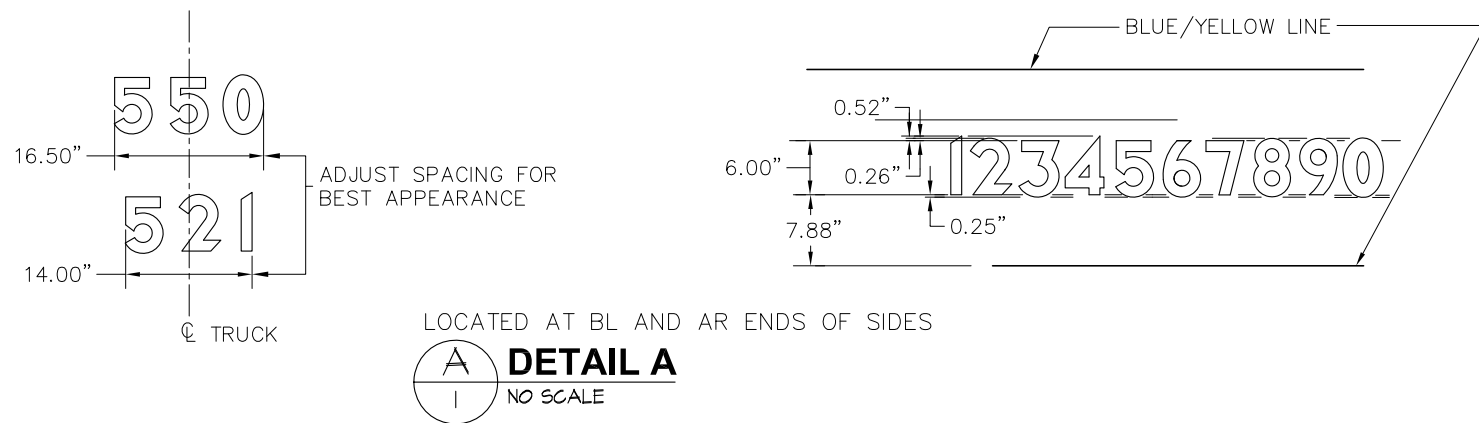

**DETAIL A**  
NO SCALE

**GENERAL NOTES:**

- DO NOT PAINT STAINLESS STEEL APPLIANCES, OTHER BRIGHT METAL, COUPLERS OR WHEELS.
- ALL PAINTING TO BE IN ACCORDANCE WITH ARR SPECIFICATION FOR PAINTING OF ROLLING STOCK.
- COLOR CODE FOR TRAINLINE RECEPTACLES:  
 COMMUNICATIONS: LIGHT BLUE  
 DUMMY: WHITE  
 POWER: RED  
 LOCOMOTIVE MU: YELLOW
- DETAILS OF GRAPHICS ARE DOCUMENTED IN THE AUTOCAD FILE OF THIS DRAWING.
- DIMENSIONS SHOWN IN DETAIL E APPLY AT BODY BOLSTERS. LINES ARE TO FOLLOW CARBODY CAMBER.
- INTERIOR OF VESTIBULES ARE CONSIDERED EXTERIOR. VERTICAL SURFACES AND CEILINGS ARE TO BE PAINTED BLUE. ALASKA RAILROAD WILL REPLACE ALL VESTIBULE SIGNS.
- AEI TAGS (2) ARE SIDE SPECIFIC; MARK AND REPLACE TO SAME SIDE, SAME LOCATION.
- NEW RETRO-REFLECTIVE EMERGENCY ACCESS SIGNS WILL BE INSTALLED BY ALASKA RAILROAD.
- DRAWING DOES NOT PURPORT TO SHOW CONSTRUCTION IN ABSOLUTE AND COMPLETE DETAIL.

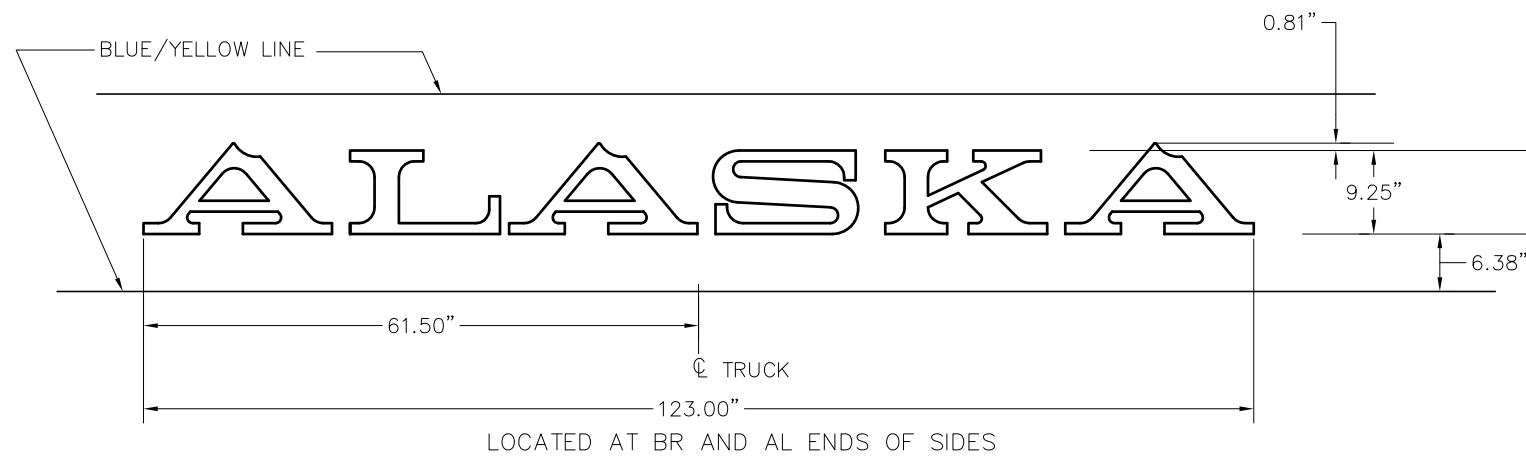

**DETAIL B**  
NO SCALE

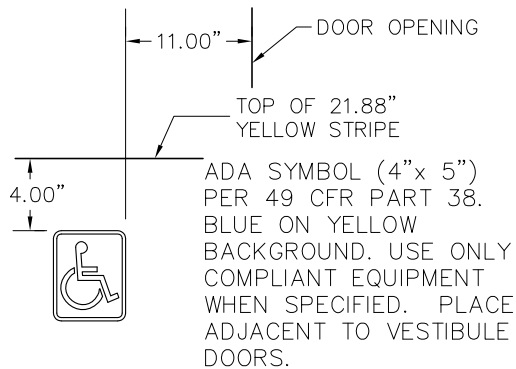

**DETAIL C**  
NO SCALE



18.00" VISUAL END OF SIDE SHEET  
 24" DIAMETER LOGOTYPE.  
 VERTICAL POSITION: MAINTAIN 18" (OR AS SPACE PERMITS) FROM VISUAL END OF SIDE (eg CORNER POST OR DOOR JAMB). OMIT IF SPACE DOES NOT PERMIT APPLICATION. LOCATED ONLY AT BL AND AR ENDS OF SIDES.

**DETAIL D**  
NO SCALE

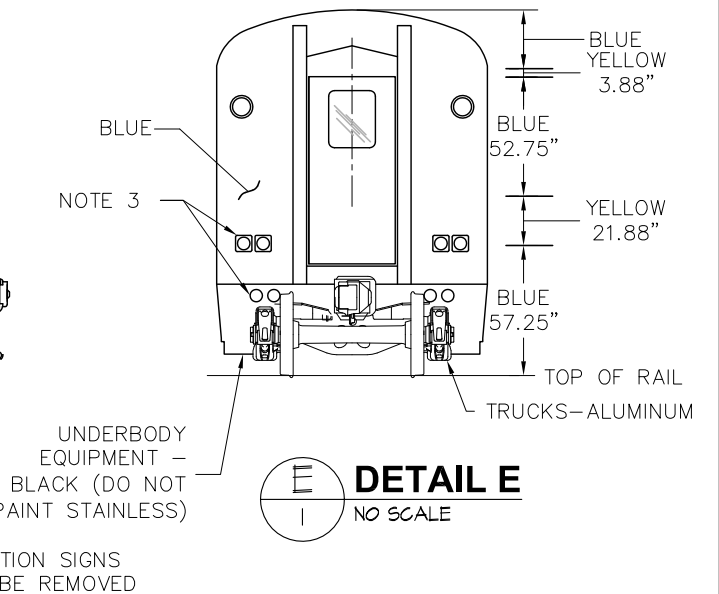
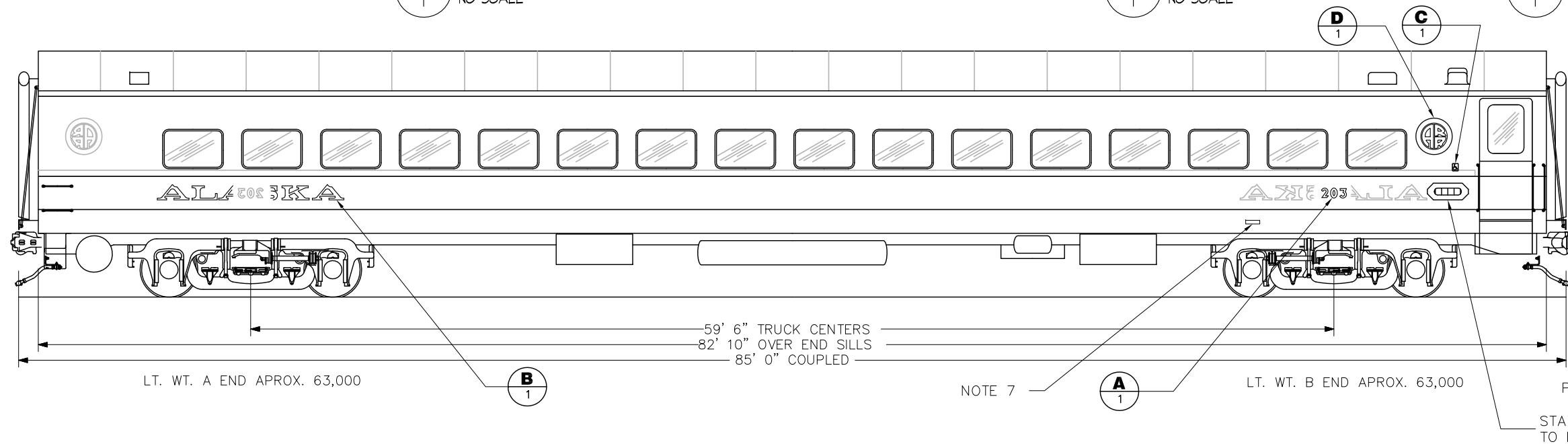

**DETAIL E**  
NO SCALE

<b>ALASKA RAILROAD CORPORATION</b> ENGINEERING SERVICES P.O. BOX 107500, ANCHORAGE, ALASKA 99510-7500		
PROJECT : <b>MOTIVE POWER AND EQUIPMENT PASSENGER COACHES</b>		
TITLE: <b>ARR 200 - 204 STYLING ELEVATION AND DETAILS</b>		
DESIGNED BY: ARR	SCALE : NO SCALE	AFE NO.:
DRAWN BY: ARR	DATE : FEBRUARY 2017	ACAD FILE:
CHECKED BY: ARR		DWG NO. <b>1</b> OF <b>1</b>
APPROVED BY: ARR		

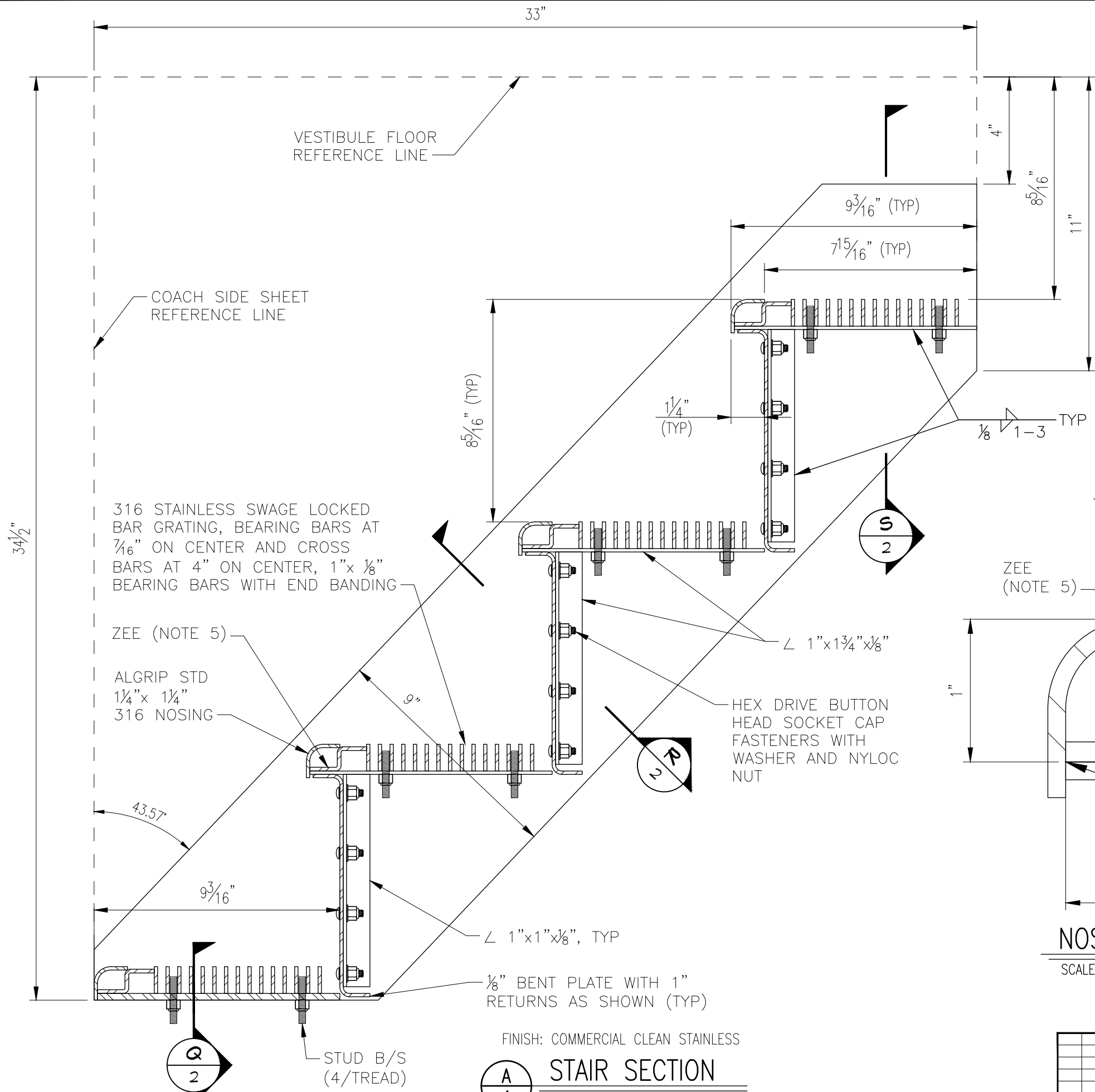

- NOTES:
1. CONFIRM WIDTH DIMENSIONS OF OPENING FOLLOWING REPAIRS BY ALASKA INDUSTRIAL PAINT. RISE/RUN AND WIDTH MAY NEED TO BE ADJUSTED TO ACCOMMODATE COACH DIMENSIONS.
  2. PROVIDE SHOP DRAWINGS FOR ALASKA RAILROAD REVIEW.
  3. ALL MATERIALS ARE 316 STAINLESS STEEL UNLESS OTHERWISE NOTED.
  4. PROVIDE ALL FASTENERS WITH STAINLESS WASHERS UNDER TURNED ELEMENT AND NYLOC NUTS. A MINIMUM OF 1 1/2 THREADS MUST EXTEND BEYOND NUTS.
  5. FABRICATE ZEE FROM 10 GA SS.

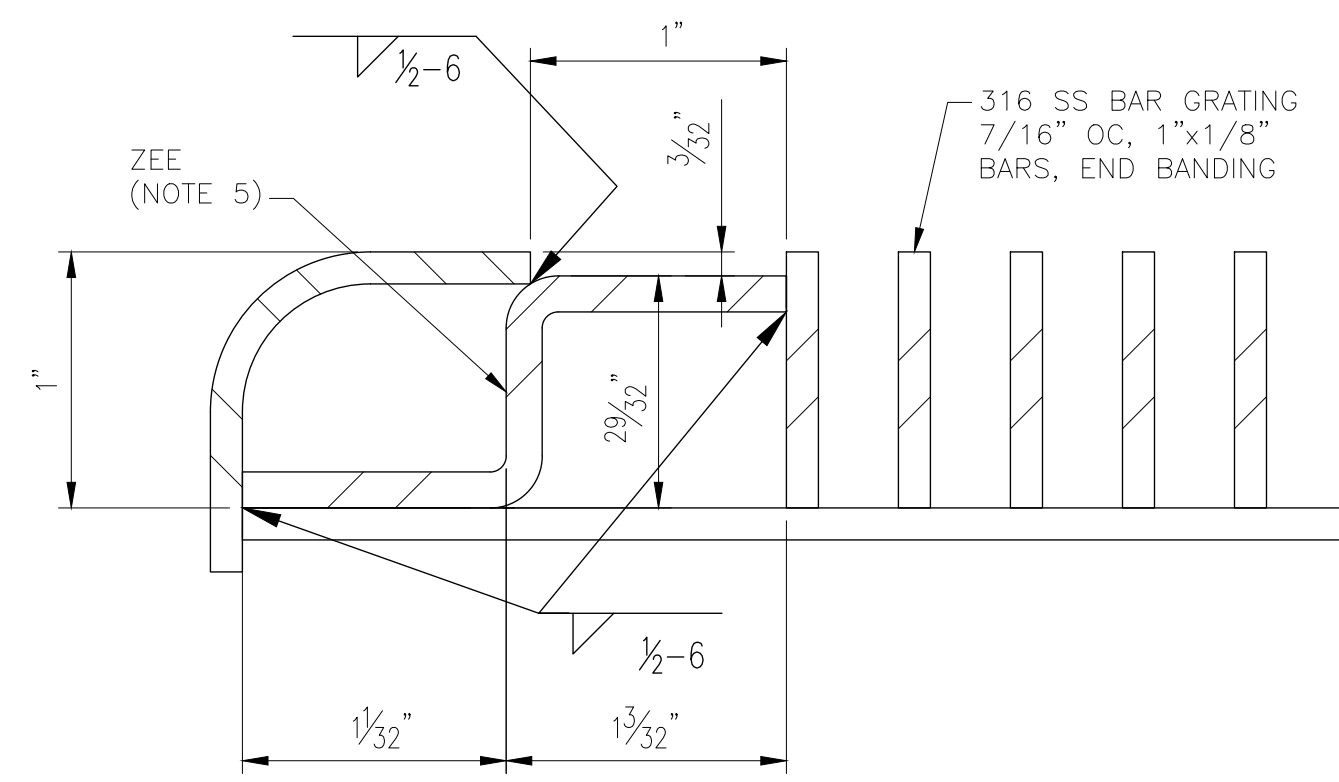

**NOSING WELD DETAIL**  
SCALE: NTS

**A 1**  
**STAIR SECTION**  
SCALE: 3" = 1'-0"

<b>ALASKA RAILROAD CORPORATION</b> ENGINEERING SERVICES P.O. BOX 107500, ANCHORAGE, ALASKA 99510-7500			
PROJECT : <b>MOTIVE POWER AND EQUIPMENT PASSENGER EQUIPMENT</b>			
TITLE: <b>ARR PASSENGER COACH FIXED VESTIBULE STAIR ASSEMBLY</b>			
DESIGNED BY: ARRC	SCALE : 3" = 1'-0"	AFE NO.:	
DRAWN BY: ARRC	DATE : APRIL 2017	ACAD FILE:	
CHECKED BY: ARRC		DWG NO. <b>1</b> OF <b>2</b>	
APPROVED BY: ARRC			

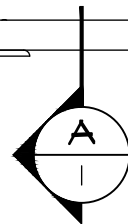
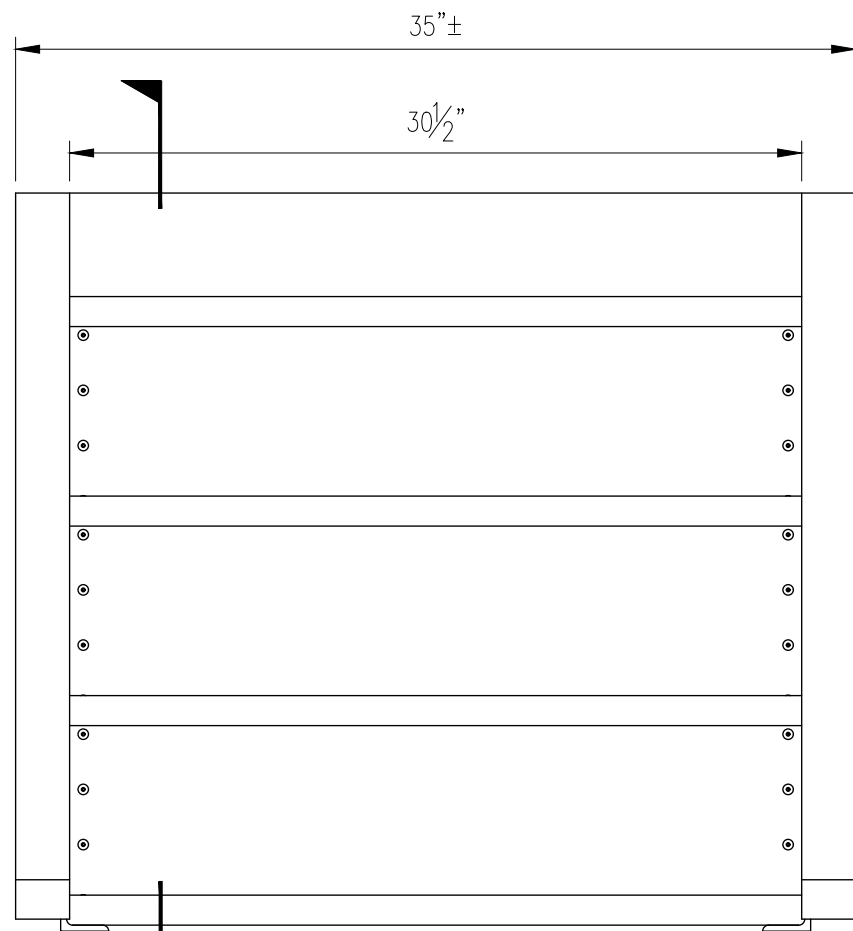

**STAIR ELEVATION**  
SCALE: 1 1/2" = 1'-0"

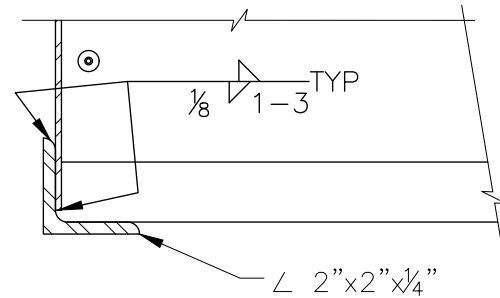

**SECTION Q**  
SCALE: 3" = 1'-0"

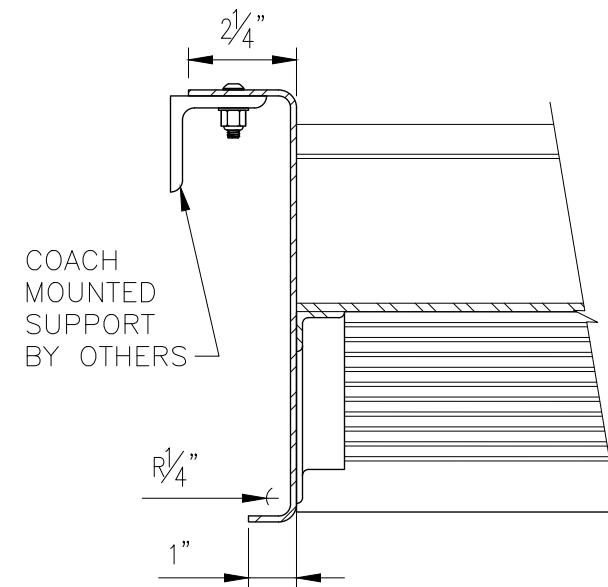

**SECTION R**  
SCALE: 3" = 1'-0"

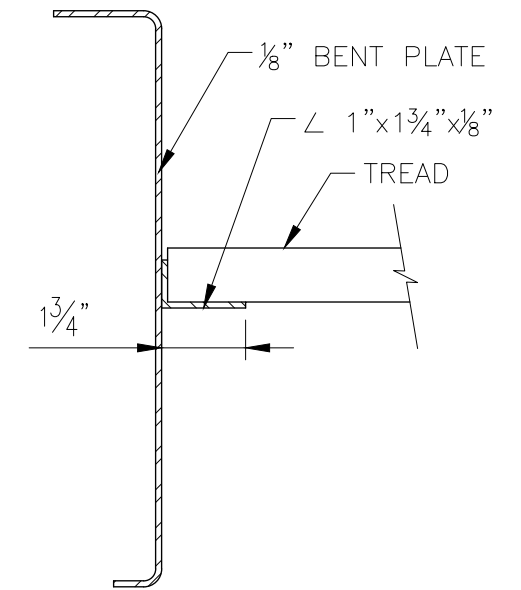

**SECTION S**  
SCALE: 3" = 1'-0"



PROVIDE CUT-OUT IN STAIR SUPPORT PLATE TO ACCOMMODATE THIS OBJECT

**DETAIL**  
SCALE: NTS

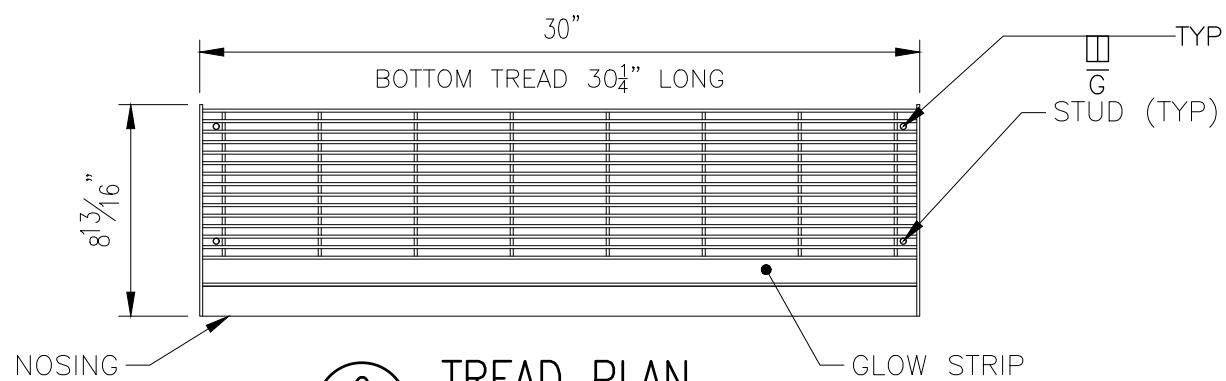

**TREAD PLAN**  
SCALE: 1 1/2" = 1'-0"

REV.	DATE	BY	REVISION

<b>ALASKA RAILROAD CORPORATION</b> ENGINEERING SERVICES P.O. BOX 107500, ANCHORAGE, ALASKA 99510-7500		
PROJECT : <b>MOTIVE POWER AND EQUIPMENT PASSENGER EQUIPMENT</b>		
TITLE: <b>ARR PASSENGER COACH FIXED VESTIBULE STAIR ASSEMBLY</b>		
DESIGNED BY: ARRC	SCALE : AS NOTED	AFE NO.:
DRAWN BY: ARRC	DATE : APRIL 2017	ACAD FILE:
CHECKED BY: ARRC		DWG NO. <b>2</b> OF <b>2</b>
APPROVED BY: ARRC		

## **APPENDIX D**

### **COST SCHEDULE**

**COST SCHEDULE:** A bidder's failure to provide the information requested in this Appendix will be cause for rejection of the offer on the basis of non-responsiveness. Cost shall be bid in accordance to all specifications in Appendix C, and any Technical Specifications incorporated herein.

All prices quoted will be F.O.B. EXW from the approved facility that the work outlined herein is to be performed at.

**EVALUATION FACTORS:** Per the ARRC Procurement Rules outlined under 1300.4-A, the following factors may be, but are not limited to being, used in determining whom the responsive low bidder is:

- (8) Transportation charges (*shipping costs for the coaches to and from the approved facility*); and,
- (10) Other factors determined to be pertinent or peculiar to the procurement (e.g. *airfare or other costs associated with inspections*).

For the purposes of this bid, the quantity of hours used to determine the labor rates for each coach were calculated from an internal estimate. The estimated hourly quantities below are; however, not guaranteed and are solely for the ARRC's use to compare bids and determine an initial Contract value.

Payment to the Contractor will be made based on the actual accepted and approved quantities of hours exhausted and for materials furnished in conformance with the Contract Documents.

Markup on materials will be limited to 10% and receipts will be required for payment.

**AWARD CRITERIA:** An award will be made to the low, responsive, responsible bidder that meets the requirements set forth herein in the specifications and compliance thereof.

The ARRC reserves the right to determine that all offered materials will serve the application intended and be in the best interest of the ARRC. Award will be made in the aggregate or by line item, whichever is deemed, by the Contract Administrator, to be in the best interest of the ARRC. This may result in multiple awards. The bid award is contingent on the availability of Federal Transit Administration and ARRC funds.



## ARRC Passenger Coach Painting and Repair

Item No.	Item Description	Unit	Quantity <sup>2</sup>	Unit Bid Price	Amount Bid
1.a	Paint Application - ARR 200	Lump Sum	1		
1.b	Paint Application - ARR 201	Lump Sum	1		
2.a	Miscellaneous Coach Repair - ARR 200	Hour	1		
2.b	Miscellaneous Coach Repair - ARR 201	Hour	1		
<b>Total Bid for ARR 200 &amp; ARR 201 <sup>1</sup>:</b>					

Notes:

<sup>1</sup> Award of this proposal is to be made on total derived from the sum of the Base Bid items.

<sup>2</sup> Bid quantities are approximate. Contractor is responsible for their own quantity take-offs using the information within the Contract Documents to verify the quantities in the Cost Schedule.

**NON-COLLUSION AFFIDAVIT:** The Undersigned declares, under penalty of perjury under the laws of the United States, that neither he/she nor the firm, association, or corporation of which he/she is a member, has, either directly or indirectly, entered into any agreement, participated in any collusion, or otherwise taken any action in restraint of free competitive bidding in connection with this Bid.

The Undersigned has read the foregoing proposal and hereby agrees to the conditions stated therein by affixing his/her signature below:

**BIDDERS NAME AND ADDRESS**

\_\_\_\_\_  
COMPANY NAME

\_\_\_\_\_  
SIGNATURE BY AND FOR THE BIDDER

\_\_\_\_\_  
COMPANY MAILING ADDRESS

\_\_\_\_\_  
PRINTED NAME OF ABOVE BIDDER

\_\_\_\_\_  
CITY, STATE ZIP CODE

\_\_\_\_\_  
DATE OF BID

\_\_\_\_\_  
CONTACT PHONE NUMBER

\_\_\_\_\_  
CONTACT E-MAIL

## APPENDIX E

### BIDDERS QUESTIONNAIRE

#### PART I - INSTRUCTIONS

1. All Bidders/Proposers submitting a Bid/Proposal for federally funded contracts are to complete and submit all Parts of this Questionnaire with their Bid or Proposal. Failure to complete and return this questionnaire, any false statements, or failure to answer question when required, may render the bid/proposal non-responsive. All responses must be typewritten or printed in ink. All information must be legible.
2. Please state "not applicable" in questions clearly not applicable to Bidder/Proposer in connection with this solicitation. Do not omit any question.
3. The completed Questionnaire must be sworn to by a partner (if partnership), a duly authorized officer or individual (if a corporation or LLC), or a principal (if a sole proprietorship).
4. The term "Proposer" includes the term "Bidder" and also refers to the firm awarded the Contract. The term "Proposal" includes the term "Bid".
5. ARRC reserves the right to inquire further with respect to Proposer's responses; and Proposer consents to such further inquiry and agrees to furnish all relevant documents and information as requested by ARRC. Any response to this document prior or subsequent to Proposer's Proposal which is or may be construed as unfavorable to Proposer will not necessarily automatically result in a negative finding on the question of Proposer's responsibility or a decision to terminate the contract if it is awarded to Proposer.

#### PART II - IDENTITY OF PROPOSER

1. Proposer's Full Legal Name: \_\_\_\_\_
2. The Proposer represents that it operates as the following form of legal entity: (Check whichever applies and fill in any appropriate blanks.)
  - an individual or sole proprietorship
  - a general partnership
  - a limited partnership
  - a joint venture consisting of: \_\_\_\_\_  
and \_\_\_\_\_  
(List all joint ventures on a separate sheet if this space is inadequate.)
  - a non-profit organization
  - a corporation organized or incorporated under the laws of the following state or country: \_\_\_\_\_  
on the following date: \_\_\_\_\_
  - a limited liability company organized under the laws of the following state or country: \_\_\_\_\_  
on the following date: \_\_\_\_\_
3. Proposer's federal taxpayer identification number: \_\_\_\_\_
4. Proposer's Alaska business license number: \_\_\_\_\_
5. Proposer's contractor's license number (for construction only): \_\_\_\_\_
6. Proposer's legal address: \_\_\_\_\_  
\_\_\_\_\_

Telephone Number: (\_\_\_\_) \_\_\_\_\_ Fax Number: (\_\_\_\_) \_\_\_\_\_

7. Proposer's local or authorized point of contract address:

Name: \_\_\_\_\_ Title: \_\_\_\_\_

Address: \_\_\_\_\_

8. Telephone Number: (\_\_\_\_) \_\_\_\_\_ Fax Number: (\_\_\_\_) \_\_\_\_\_  
How long has the Proposer been in business? \_\_\_\_\_

9. Has Proposer been in business under another name? If so, identify name and dates used.

\_\_\_\_\_  
\_\_\_\_\_

10. Does your firm consider itself to be an MBE, WBE or DBE?

YES  NO

If answer is "YES," attach a copy of certification.

11. Number of employees: \_\_\_\_\_ including \_\_\_\_\_ employees in the State of Alaska.

### PART III-CONTRACTING HISTORY

1. Has the Proposer been awarded any contracts within the last five years by ARRC, the State of Alaska, or any other public entity for the same or reasonably similar goods or services sought by this solicitation? If none, answer "No". If yes, on a separate sheet of paper describe those contracts beginning with the most recent. State the name of the contracting entity; give a brief description of the contract and the contract number, the dollar amount at award and at completion, date completed; state the contract period, the status of the contract, and the name, address, and telephone number of a contact person at the agency. Indicate if award was made to Proposer as prime contractor or joint venture. Proposer need not provide more than three such descriptions.

YES  NO

2. Has the Proposer been awarded any private sector contracts within the last five years for the same or reasonably similar goods or services sought by this solicitation? If none, answer "No." If yes, on a separate sheet of paper provide the name and address of the contracting entity, a brief description of work, the dollar amount at award and at completion, date completed, status of the contract and name, address and telephone number of contact person as to each, beginning with the most recent. Indicate if Proposer acted as prime contractor or joint venture. Proposers need not provide more than three such descriptions.

YES  NO

NOTE: ANY "YES" ANSWERS TO #3 BELOW MUST BE FULLY EXPLAINED ON A SEPARATE SHEET OF PAPER AND ATTACHED TO THIS QUESTIONNAIRE.

3. In the past five years has the Proposer been the subject of any of the following actions?

A. Been suspended, debarred, disqualified, or otherwise declared ineligible to bid?

YES  NO

B. Failed to complete a contract for a public or private entity?

YES  NO

- C. Been denied a low-bid contract in spite of being the low bidder?  
YES  NO
- D. Had a contract terminated for any reason, including default?  
YES  NO
- E. Had liquidated damages assessed against it during or after completion of a contract?  
YES  NO
- F. Been a defaulter, as principal, surety or otherwise?  
YES  NO
- G. Been denied an award of a public contract based upon a finding by a public agency that your company was not a responsible contractor?  
YES  NO
- H. A public entity requested or required enforcement of any of its rights under a surety agreement on the basis of your company's default or in lieu of declaring your company in default?  
YES  NO
- I. Been denied a performance or payment bond by a surety company?  
YES  NO
- J. Been required to pay back wages and/or penalties for failure to comply with state or federal prevailing wage or overtime laws?  
YES  NO
4. Does Proposer currently possess the financial, organizational, technical, equipment, facilities, and other resources necessary to supply the goods or services sought by this solicitation? If no, on a separate sheet of paper describe how you intend to obtain the resources necessary to supply the goods or services sought by this solicitation.  
YES  NO
5. Does Proposer have any present or anticipated commitments and/or contractual obligations that might impact its ability to meet the required delivery or performance requirements of this solicitation? If yes, on a separate sheet of paper describe any apparent conflicts as between the requirements/commitments for this solicitation with respect to the use of Proposer's resources, such as management, technical expertise, financing, facilities, equipment, etc.  
YES  NO

#### PART IV-CIVIL ACTIONS

If "Yes" to Parts IV or V, provide details on a separate sheet of paper including a brief summary of cause(s) of action; indicate if Proposer, its principals, officers or partners were plaintiffs or defendants; define charges explicitly, by what authority, court or jurisdiction, etc. In the case of tax liens, please indicate whether the liens were resolved with the tax authorities. Please submit proof of payment or agreements to pay the liens. Complete details are required!

1. Violations Of Civil Law. In the past five years has Proposer, any of its principals, officers or partners been the subject of an investigation of any alleged violation of a civil antitrust law, or other federal, state or local civil law?  
YES  NO

2. Lawsuits With Public Agencies. At the present time is, or during the past five years has Proposer, any of its principals, officers or partners been a plaintiff or defendant in any lawsuit or arbitration regarding services or goods provided to a public agency?

YES  NO

3. Bankruptcy. During the past five years, has the Proposer filed for bankruptcy or reorganization under the bankruptcy laws?

YES  NO

4. Judgments, Liens And Claims. During the past five years, has the Proposer been the subject of a judgment, lien or claim of \$25,000 or more by a subcontractor or supplier?

YES  NO

5. Tax Liens. During the past five years, has the Proposer been the subject of a tax lien by federal, state or any other tax authority?

YES  NO

#### PART V-COMPLIANCE WITH LAWS AND OTHER REGULATIONS

1. Criminal: In the past five years has the Proposer, any of its principals, officers, or partners been convicted or currently charged with any of the following:

A. Fraud in connection with obtaining, attempting to obtain, or performing a public contract, agreement or transaction?

YES  NO

B. Federal or state antitrust statutes, including price fixing collusion and bid rigging?

YES  NO

C. Embezzlement, theft, forgery, bribery, making false statements, submitting false information, receiving stolen property, or making false claims to any public agency?

YES  NO

D. Misrepresenting minority or disadvantaged business entity status with regard to itself or one of its subcontractors?

YES  NO

E. Non-compliance with the prevailing wage requirements of the State of Alaska or similar laws of any other state?

YES  NO

F. Violation of any law, regulation or agreement relating to a conflict of interest with respect to a government funded procurement?

YES  NO

G. Falsification, concealment, withholding and/or destruction of records relating to a public agreement or transaction?

YES  NO

H. Violation of a statutory or regulatory provision or requirement applicable to a public or private agreement or transaction?

YES  NO

I. Do any principals, officers or partners in Proposer's company have any felony charges pending against them that were filed before, during, or after their employment with the Proposer?  
YES  NO

2. Regulatory Compliance. In the past five years, has Proposer or any of its principals, officers or partners:

A. Been cited for a violation of any labor law or regulation, including, but not limited to, child labor violations, failure to pay correct wages, failure to pay into a trust account, failure to remit or pay withheld taxes to tax authorities or unemployment insurance tax delinquencies?  
YES  NO

B. Been cited and assessed penalties for an OSHA or Alaska/OSHA "serious violation"?  
YES  NO

C. Been cited for a violation of federal, state or local environmental laws or regulations?  
YES  NO

D. Failed to comply with Alaska corporate registration, federal, state or local licensing requirements?  
YES  NO

E. Had its corporate status, business entity's license or any professional certification, suspended, revoked, or had otherwise been prohibited from doing business in the State of Alaska?  
YES  NO

#### PART VI-FINANCIAL

Copies of the following documents are to be submitted with this Questionnaire:

1. Proposer's current Alaska Business License, if required by state law.

2. Proposer's Financial Statements (see specific requirements below):

A. PUBLICLY TRADED COMPANIES: Financial information will be accessed on-line. However, if additional information is needed, it will be specifically requested from the Proposer.

B. NON-PUBLICLY TRADED COMPANIES WITH AUDITED OR REVIEWED FINANCIAL STATEMENTS: Statements, including balance sheet, statement of earnings and retained income, with footnotes, for the most recent three years.

C. NON-PUBLICLY TRADED COMPANIES WITHOUT AUDITED OR REVIEWED FINANCIAL STATEMENTS: Company generated financial statements, including balance sheet, statement of earnings and retained income for the most recent three years. The Chief Financial Officer of the corporation, a partner, or owner, as appropriate, must certify these financial statements.

D. SOLE PROPRIETORSHIPS: Refer to C. If financial statements are not generated, please fill out and sign the Financial Statement form attached hereto. Submit one form for each of the most recent three years.

NOTE: ARRC reserves the right to ask for additional documentation if it is reasonably required to make a determination of integrity and responsibility relevant to the goods or services the Proposer will provide to ARRC if awarded a contract. All financial information provided is considered confidential and not subject to public disclosure under Alaska law.

PART VII -VERIFICATION AND ACKNOWLEDGMENT

The undersigned recognizes that the information submitted in the questionnaire herein is for the express purpose of inducing ARRC to award a contract, or to allow Proposer to participate in ARRC projects as contractor, subcontractor, vendor, supplier, or consultant. The undersigned has read and understands the instructions for completing this Questionnaire.

STATE OF \_\_\_\_\_

COUNTY OF \_\_\_\_\_

I, (printed name) \_\_\_\_\_, being first duly sworn, state that I am the (title) \_\_\_\_\_ of Proposer. I certify that I have read and understood the questions contained in the attached Questionnaire, and that to the best of my knowledge and belief all information contained herein and submitted concurrently or in supplemental documents with this Questionnaire is complete, current, and true. I further acknowledge that any false, deceptive or fraudulent statements on the Questionnaire will result in denial or termination of a contract.

I authorize ARRC to contact any entity named herein, or any other internal or outside resource, for the purpose of verifying information provided in the Questionnaire or to develop other information deemed relevant by ARRC.

\_\_\_\_\_  
Signature of Certifying Individual

\_\_\_\_\_  
Date

Subscribed and sworn to before me this \_\_\_\_\_ day of \_\_\_\_\_, 20\_\_

\_\_\_\_\_  
Signature of Notary

Notary Public in and for the State of \_\_\_\_\_

My Commission Expires: \_\_\_\_\_

NOTICE TO PROPOSERS

A material false statement, omission or fraudulent inducement made in connection with this Questionnaire is sufficient cause for denial of a contract award or revocation of a prior contract award, thereby precluding the Proposer from doing business with, or performing work for ARRC, either as a vendor, prime contractor, subcontractor, consultant or subconsultant for a period of five years. In addition, such false submission may subject the person and/or entity making the false statement to criminal charges under applicable state and/or federal law.

## Financial Statement

To be completed by Proposers that do not produce company generated financial statements, including balance sheet, statement of earnings and retained income for the most recent three years (one sheet per year.)

### ASSETS

Cash on Hand and in Banks	\$ _____
Account and Notes Receivable	\$ _____
Fixed Assets (net of depreciation)	\$ _____
Other Assets	\$ _____
Total Assets	\$ _____

### LIABILITIES

Accounts Payable	\$ _____
Notes Payable to Banks in next twelve months	\$ _____
Notes Payable to Others	\$ _____
Taxes Payable	\$ _____
Long Term Liabilities (More than twelve months)	\$ _____
Other Liabilities	\$ _____
Total Liabilities	\$ _____
Net Worth	\$ _____

### INCOME FROM OPERATIONS

Revenue	\$ _____
Interest	\$ _____
Cost of Goods Sold (if appropriate)	\$ _____
Gross Profit	\$ _____
General & Administrative Expenses	\$ _____
Depreciation	\$ _____
Interest Paid	\$ _____
Net Gain or Loss	\$ _____



I hereby certify that the above information is true and accurate to the best of my knowledge and belief. I understand false statements may result in denial of a contract, and possible debarment for a period of five years.

\_\_\_\_\_  
Signature of Owner or Officer

\_\_\_\_\_  
Date Signed

\_\_\_\_\_  
Company Name

\_\_\_\_\_  
For the Year Ended

\_\_\_\_\_  
Federal ID

**APPENDIX F  
ALASKA RAILROAD CORPORATION  
SUPPLY BID FORM**

**NAME** \_\_\_\_\_

**ADDRESS** \_\_\_\_\_

\_\_\_\_\_

**To the CONTRACTING OFFICER, ALASKA RAILROAD CORPORATION:**

In compliance with your Invitation for Bids No.: \_\_\_\_\_, dated \_\_\_\_\_, the Undersigned proposes to furnish and deliver all the supplies, materials or equipment and perform all the work required in said Invitation according to the specifications and requirements contained therein and for the amount and prices named herein as indicated on the Cost Schedule, which is made a part of this Bid.

The Undersigned hereby agrees to execute the said contract and bonds, if any, within **Ten (10) Calendar Days**, or such further time as may be allowed in writing by the Contracting Officer, after receiving notification of the acceptance of this Bid, and it is hereby mutually understood and agreed that in case the Undersigned does not, the accompanying bid guarantee, if any, shall be forfeited to the Alaska Railroad Corporation as liquidated damages, and said Contracting Officer may proceed to award the contract to others.

The Undersigned agrees to commence performance within **Ten (10) Calendar Days** after the effective date of the Notice to Proceed and to complete performance by \_\_\_\_\_, unless extended in writing by the Contracting Officer.

The Undersigned acknowledges receipt of the following addenda to the requirements and/or specifications for this Invitation for Bids (give number and date of each).

Addendum Number/Dated	Addendum Number/Dated	Addendum Number/Dated
_____	_____	_____
_____	_____	_____

**NON-COLLUSION AFFIDAVIT**

The Undersigned declares, under penalty of perjury under the laws of the United States, that neither he/she nor the firm, association, or corporation of which he/she is a member, has, either directly or indirectly, entered into any agreement, participated in any collusion, or otherwise taken any action in restraint of free competitive bidding in connection with this Bid.

\_\_\_\_\_

The Undersigned has read the foregoing proposal and hereby agrees to the conditions stated therein by affixing his/her signature below:

\_\_\_\_\_  
Name and Title of Person Signing

\_\_\_\_\_  
Signature

\_\_\_\_\_  
Telephone Number

\_\_\_\_\_  
Facsimile Number      Form 395-0132

## APPENDIX G

### GENERAL TERMS AND CONDITIONS (General Service Contracts) (Revised 4/29/08)

The following terms and conditions supersede the terms and conditions on the reverse side of ARRC's purchase order to the extent that they are inconsistent therewith and shall be deemed to have the same force and effect as though expressly stated in any such purchase order into which this document is incorporated.

1. Definitions.

"ARRC" shall mean the Alaska Railroad Corporation.

"Contractor" shall mean the person or entity entering into the contract to perform the work or services specified therein for ARRC.

"Contract" shall mean these General Terms and Conditions, the contract form to which they are annexed, and all other terms, conditions, schedules, appendices or other documents attached to the contract form or incorporated by reference therein.

"Services" shall mean any work, labor, time, effort or other services furnished by Contractor to ARRC under the contract.

2. Inspection and Reports. ARRC may inspect all of the Contractor's facilities and activities under this contract in accordance with the provisions of ARRC Procurement Rule 1600.9. The Contractor shall make progress and other reports in the manner and at the times ARRC reasonably requires.

3. Claims. Any claim by Contractor for additional compensation or equitable adjustment arising under this contract which is not disposed of by mutual agreement must be made by Contractor in accordance with the time limits and procedures specified in sections 1800.12 et seq. of ARRC's Procurement Rules, which by this reference are hereby incorporated herein.

4. Nondiscrimination.

4.1 The Contractor may not discriminate against any employee or applicant for employment because of race, religion, color, national origin, ancestry, physical or mental handicap, sex, marital status, change in marital status, pregnancy or parenthood when the reasonable demands of the positions do not require distinction on the basis of age, physical handicap, sex, marital status, changes in marital status, pregnancy, or parenthood. To the extent required by law, the Contractor shall take affirmative action to insure that the applicants are considered for employment and that employees are treated during employment without unlawful regard to their race, color, religion, national origin, ancestry, physical or mental handicap, age, sex, marital status, changes in marital status, pregnancy or parenthood. This action must include, but need not be limited to, the following: employment, upgrading, demotion, transfer, recruitment or recruitment advertising, layoff or termination, rates of pay or other forms of compensation, and selection for training including apprenticeship. The Contractor shall post in conspicuous places,

available to employees and applicants for employment, notices setting out the provisions of this paragraph.

4.2 The Contractor shall cooperate fully with ARRC efforts which seek to deal with the problem of unlawful discrimination, and with all other ARRC efforts to guarantee fair employment practices under this contract, and promptly comply with all requests and directions from the State Commission for Human Rights or any of its officers or agents relating to prevention of discriminatory employment practices.

4.3 Full cooperation in Paragraph 4.2 includes, but is not limited to, being a witness in any proceeding involving questions of unlawful discrimination if that is requested by any official or agency of the State of Alaska; permitting employees of the Contractor to be witnesses or complainants in any proceeding involving questions of unlawful discrimination, if that is requested by any official or agency of the State of Alaska; participating in meetings; submitting periodic reports on the equal employment aspects of present and future employment; assisting inspection of the Contractor's facilities; and promptly complying with all State directives considered essential by any office or agency of the State of Alaska to insure compliance with all federal and state laws, regulations, and policies pertaining to the prevention of discriminatory employment practices.

4.4 Failure to perform under this section constitutes a material breach of the contract.

## 5. Cancellation/Termination.

5.1 ARRC may, for its sole convenience, cancel this contract in whole or in part, at any time by giving written notice of its intention to do so. In the event of such cancellation, Contractor shall be entitled to receive payment in accordance with the payment provisions of this contract for services rendered or charges incurred prior to the effective date of termination. Contractor shall not be paid for any work done after receipt of a notice of cancellation or for any costs incurred by Contractor's suppliers or subcontractors which Contractor could reasonably have avoided. In no event shall ARRC be liable for unabsorbed overhead or anticipatory profit on unperformed services.

5.2 In addition to ARRC's right to cancel this contract for its convenience, ARRC may, by written notice of default to Contractor, terminate the contract in whole or in part in the following circumstances:

(1) The Contractor refuses or fails to perform its obligations under the contract, or fails to make progress so as to significantly endanger timely completion or performance of the contract in accordance with its terms, and Contractor does not cure such default within a period of ten (10) days after receipt of written notice of default from ARRC or within such additional cure period as ARRC may authorize; or

(2) Reasonable grounds for insecurity arise with respect to Contractor's expected performance and Contractor fails to furnish adequate assurance of due performance (including assurance of performance in accordance with the time requirements of the contract) within ten (10) days after receipt of a written request by ARRC for adequate assurance; or

(3) Contractor becomes insolvent or makes an assignment for the benefit of creditors or commits an act of bankruptcy or files or has filed against it a petition in bankruptcy or reorganization proceedings.

5.3 Upon receipt of a notice of cancellation or termination, Contractor shall immediately discontinue all service and it shall immediately cause any of its suppliers or subcontractors to cease such work unless the notice directs otherwise and deliver immediately to ARRC all reports, plans, drawings, specifications, data, summaries or other material and information, whether completed or in process, accumulated by Contractor in performance of the contract. In the event of termination for default, Contractor shall not be entitled to receive any further payment until the work is finished. If the unpaid balance of the amount to be paid on this contract exceeds the expense of finishing the work, compensation for additional managerial and administrative services and such other costs and damages as ARRC may suffer as a result of Contractor's default, such excess shall be paid to Contractor. If such expense, compensation, costs and damages shall exceed such unpaid balance, Contractor shall be liable for and shall pay the differences to ARRC. The rights and remedies of ARRC provided in this section shall not be exclusive and are in addition to any other rights and remedies provided by law.

6. No Assignment or Delegation. The Contractor may not assign, subcontract or delegate this contract, or any part of it, or any right to any of the money to be paid under it, except with the prior written consent of ARRC. The hiring or use of outside services, subcontractors or consultants in connection with the work shall not be permitted without the prior written approval of ARRC. No such approval shall relieve Contractor from any of its obligations or liabilities under this contract.

7. Independent Contractor. The Contractor's relationship to ARRC in performing this contract is that of an independent contractor and nothing herein shall be construed as creating an employer/employee relationship, partnership, joint venture or other business group or concerted action. The personnel performing services under this contract shall at all times be under Contractor's exclusive direction and control and shall be employees of the Contractor, and not of ARRC.

8. Payment of Taxes. As a condition of performance of this contract, the Contractor shall pay all federal, state, and local taxes incurred by the Contractor and shall require their payment by any subcontractor or any other persons in the performance of this contract. Satisfactory performance of this paragraph is a condition precedent to payment by ARRC under this contract.

9. Governing Law. This contract, and all questions concerning the capacity of the parties, execution, validity (or invalidity) and performance of this contract, shall be interpreted, construed and enforced in all respects in accordance with the laws of the State of Alaska.

10. Alaska Executive Branch Ethics Act Requirements. No officer or employee of the State of Alaska or of the ARRC and no director of the ARRC or legislator of the state shall be admitted to any share or part of this contract or to any benefit that may arise therefrom. Contractor shall exercise reasonable care and diligence to prevent any actions or conditions which could be a violation of Alaska Statute 39.52 et seq. Contractor shall not make or receive any payments, gifts, favors, entertainment, trips, secret commissions, or hidden gratuities for the purpose of securing preferential treatment or action from or to any party. This obligation will apply to the activities of Contractor's employees and agents in their relations with ARRC employees, their families, vendors, subcontractors, and third parties arising from this contract and in accomplishing work hereunder. Certain gratuities may be given or accepted if:

- (1) there is no violation of any law or generally accepted ethical standards;

(2) the gratuity is given as a courtesy for a courtesy received and does not result in any preferential treatment or action;

(3) the gratuity is of limited value (less than \$150) and could not be construed as a bribe, payoff or deal; and

(4) public disclosure would not embarrass ARRC.

ARRC may cancel this contract without penalty or obligation in the event Contractor or its employees violate the provisions of this section.

11. Non-Disclosure of Confidential Information. Contractor acknowledges and agrees that for and during the entire term of this contract, any information, data, figures, projections, estimates, reports and the like received, obtained or generated by Contractor pursuant to the performance of this contract shall be considered and kept as the private, confidential and privileged records of ARRC and will not be divulged to any person, firm, corporation, regulatory agency or any other entity except upon the prior written consent of ARRC. Furthermore, upon termination of this contract, Contractor agrees that it will continue to treat as private, privileged and confidential any information, data, figures, projections, estimates, reports and the like received, obtained or generated by Contractor during the term of the contract and will not release any such information to any person, firm, corporation, regulatory agency or any other entity, either by statement, deposition or as a witness except upon the express written authority of ARRC. ARRC shall be entitled to an injunction by any competent court to enjoin and restrain the unauthorized disclosure of such information.

Contractor's agreement of non-disclosure as specified in this section applies except to the extent required for (1) performance of services under this contract; (2) compliance with standards of conduct for preservation of the public safety, health, and welfare (so long as Contractor has given ARRC prior notice of the potential hazard and ARRC has had a reasonable opportunity to correct the hazard prior to disclosure); (3) compliance with a court order or subpoena directed against Contractor (so long as Contractor has given ARRC prior notice of such and ARRC has had an opportunity to contest the same in a court of law); or (4) Contractor's defense against claims arising from performance of services under this contract.

12. Covenant Against Contingent Fees. Contractor warrants that it has not employed or retained any company or person, other than a bona fide employee working solely for Contractor, to solicit or secure this contract, and that it has not paid or agreed to pay any person, company, individual, or firm any commission, gift, percentage, fee, contingent upon or resulting from the award or making of this contract. For the breach or violation of this warranty, ARRC may terminate this contract without liability and, at its discretion, deduct from the contract price or otherwise recover the full amount of the commission, percentage, gift, or fee.

13. Standard of Performance. Contractor shall perform its services with care, skill and diligence in accordance with normally accepted industry standards and shall be responsible for the quality, accuracy, and completeness all services furnished under this Contract. Contractor shall comply with all applicable federal, state and local laws and ordinances, codes, and regulations in performing its services. If any failure to meet the foregoing standard of performance appears within one (1) year after the services are accepted by ARRC, Contractor shall, at a minimum, reperform the work at no cost to ARRC and shall reimburse ARRC for any additional costs that may be incurred by ARRC or any of its contractors or subcontractors as a result of such substandard work. If Contractor should fail to reperform the work, or if ARRC determines that

Contractor will be unable to correct substandard services before the time specified for completion of the project, if any, ARRC may correct such unsatisfactory work itself or by the use of third parties and charge Contractor for the costs thereof. The rights and remedies provided for in this section are in addition to any other remedies provided by law.

14. Warranty. In the event Contractor supplies equipment, goods, materials or other supplies in addition to services under this contract, Contractor warrants that said items: (a) shall be of good quality and free from all defects and deficiencies in workmanship, material and design; (b) shall be fit, suitable and operate successfully for their intended purpose; (c) shall be new; (d) shall be free from all liens, claims, demands, encumbrances and other defects in title; and (e) shall conform to the specifications, if any, stated in the contract. Contractor shall honor all guarantees and warranties offered by the manufacturer of the equipment, goods, materials or other supplies provided under this contract. The rights and remedies provided for in this section are in addition to any other remedies provided by law.

15. Indemnification. Contractor shall defend, indemnify and hold ARRC harmless from and against all claims and actions asserted by a third party (or parties) and related damages, losses and expenses, including attorney's fees, arising out of or resulting from the services performed or neglected to be performed by Contractor or anyone acting under its direction or control or in its behalf in the course of its performance under this contract and caused by any error, omission or negligent act, provided that Contractor's aforesaid indemnity and hold harmless agreement shall not be applicable to any liability based upon the independent negligence of ARRC. If there is a claim of, or liability for, the joint negligent error or omission of the Contractor and the independent negligence of ARRC, the indemnification and hold harmless obligation shall be apportioned on a comparative fault basis. The term "independent negligence" is negligence other than ARRC's selection, administration, monitoring, or controlling contractor and in approving or accepting Contractor's work.

16. Insurance. Without limiting Contractor's indemnification, it is agreed that Contractor shall purchase at its own expense and maintain in force at all times during the performance of services under this contract the following policies of insurance. Where specific limits are shown, it is understood that they shall be the minimum acceptable limits. If the Contractor's policy contains higher limits, ARRC shall be entitled to coverage to the extent of such higher limits. Certificates of Insurance must be furnished to the ARRC contracting officer prior to beginning work and must provide for a 30-day prior notice of cancellation, non-renewal or material change. Failure to furnish satisfactory evidence of insurance or lapse of the policy is a material breach and grounds for termination of the Contractor's services.

16.1 Workers' Compensation Insurance: The Contractor shall provide and maintain, for all employees of the Contractor engaged in work under this contract, worker's compensation insurance as required by applicable law. The Contractor shall be responsible for worker's compensation insurance for any subcontractor who directly or indirectly provides services under this contract. This coverage must include statutory coverage for states in which employees are engaging in work and employer's liability protection not less than \$100,000 per person, \$100,000 per occurrence. Where applicable, coverage for all federal acts (i.e. U.S.L. & H. and Jones Acts) must also be included.

16.2 Comprehensive (Commercial) General Liability Insurance: Covering all errors, omissions or negligent acts of the Contractor, its subcontractor(s) or anyone directly or indirectly employed by them, made in the performance of this contract which result in financial loss to ARRC. Said policy shall include premises-operations, independent contractors, products/completed operations, broad form property damage, blanket contractual and personal injury endorsements and shall name ARRC as an additional insured and contain a waiver of subrogation against ARRC and its employees. Combined single limits required are per the following schedule:

<u>Contract Amount</u>	<u>Minimum Required Limits</u>
Under \$100,000	\$ 500,000 per Occurrence/Annual Aggregate
\$100,000-\$499,999	\$1,000,000 per Occurrence/Annual Aggregate
\$500,000-\$999,999	\$2,000,000 per Occurrence/Annual Aggregate
Over \$1,000,000	Negotiable-Refer to Risk Management

16.3 Comprehensive Automobile Liability Insurance: Covering all owned, hired and non-owned vehicles with coverage limits not less than \$100,000 per person/\$300,000 per occurrence bodily injury and \$50,000 property damage. Said policy shall name ARRC as an additional insured and contain a waiver of subrogation against ARRC and its employees.

17. ARRC's Rights Not Waived by Payment. No payment made by ARRC shall be considered as acceptance of satisfactory performance of Contractor's obligations under this contract. Nor shall any payment be construed as acceptance of substandard or defective work or as relieving Contractor from its full responsibility under the contract.

18. Nonwaiver. A party's failure or delay to insist upon strict performance of any of the provisions of this contract, to exercise any rights or remedies provided by this contract or by law, or to notify the other party of any breach of or default under this contract shall not release or relieve the breaching or defaulting party from any of its obligations or warranties under this contract and shall not be deemed a waiver of any right to insist upon strict performance of this contract or any of the rights or remedies as to any subject matter contained herein; nor shall any purported oral modification or rescission of this contract operate as a waiver of any of the provisions of this contract. The rights and remedies set forth in any provision of this Agreement are in addition to any other rights or remedies afforded the nonbreaching or nondefaulting party by any other provisions of this contract, or by law.

19. Savings Clause. If any one or more of the provisions contained in thee contract shall, for any reason, be held to be invalid, illegal or unenforceable in any respect, such invalidity, illegality or unenforceability shall not affect any other provisions of this contract, but this contract shall be construed as if such invalid, illegal or unenforceable provision had never been contained herein.

20. Headings. The headings of sections and paragraphs of this contract are for convenience of reference only and are not intended to restrict, affect, or be of any weight in the interpretation or construction of the provisions of such sections or paragraphs.

21. Forum Selection. The parties shall not commence or prosecute any suit, proceeding or claim to enforce the provisions of the contract, to recover damages for breach or default under the contract, or otherwise arising under or by reason of the contract, other than in the courts of the State of Alaska for the Third Judicial District at Anchorage. The parties hereby irrevocably consent to the jurisdiction of said courts.



22. Conflict of Interest. Contractor shall act to prevent any actions or conditions which could result in a conflict with ARRC's best interests. This obligation shall apply to the activities of Contractor's employees and agents in their relationships with ARRC's employees, their families, vendors, subcontractors and third parties accomplishing work under this contract.

23. Publicity. Contractor shall not release any information for publication or advertising purposes relative to this contract or to the material, equipment and/or services furnished under this contract without the prior written consent of the ARRC.

24. Audit. ARRC has the right to audit at reasonable times the accounts and books of the Contractor in accordance with the provisions of ARRC Procurement Rule 1600.10.

25. Internal Controls and Record Keeping. Contractor shall keep full and accurate records and accounts of all of its activities in connection with this contract, including, without limitation, reasonable substantiation of all expenses incurred and all property acquired hereunder.

26. Force Majeure. Neither ARRC nor Contractor shall be responsible for failure to perform the terms of this contract when performance is prevented by force majeure, provided that: (1) notice and reasonably detailed particulars are given to the other party and (2) the cause of such failure or omission is remedied so far as possible with reasonable dispatch. The term "force majeure" shall mean acts of God, earthquakes, fire, flood, war, civil disturbances, governmentally imposed rules, regulations or other causes whatsoever, whether similar or dissimilar to the causes herein enumerated, which is not within the reasonable control of either party and which through the exercise of due diligence, a party is unable to foresee or overcome. In no event shall force majeure include normal or reasonably foreseeable or reasonably avoidable operational delays.

27. Permits and Licenses. The Contractor shall, at its own expense, obtain all necessary permits, licenses, certifications and any other similar authorizations required or which may become required by the government of the United States or any state or by any political subdivision of the United States or of any state except where laws, rules or regulations expressly require the ARRC to obtain the same.

28. Environmental Protection. When performing all obligations under the contract, Contractor shall comply with all specific instructions of ARRC with regard to environmental concerns, regardless of whether such instructions are based upon specific law, regulation or order of any governmental authority.

29. Set Off. If ARRC has any claim against the Contractor related or unrelated to this contract, it may set off the amount of such claim against any amount due or becoming due under this contract.

30. Observance of Rules. The Contractor's personnel performing work or services hereunder on ARRC's premises shall observe all fire prevention, security, and safety rules in force at the site of the work. ARRC may, in writing, require the Contractor to remove from the work site any employee ARRC deems to be incompetent, careless, or otherwise detrimental to the progress of the work, but ARRC shall have no duty to exercise this right.

31. No Third-Party Beneficiary Rights. No provision of this contract shall in any way inure to the benefit of any third parties (including the public at large) so as to constitute any such person a third-party beneficiary of the contract or of any one or more of the terms hereof, or otherwise give rise to any cause of action in any person not a party hereto.

---

32. Entire Agreement. This contract represents the entire and integrated agreement between ARRC and the Contractor and supersedes all prior negotiations, representations, or agreements, either written or oral. This contract may be amended only by a written instrument signed by both ARRC and the Contractor.

33. Key Personnel Changes. Contractor shall secure prior written approval from ARRC for any changes of key personnel assigned to perform services under this contract. ARRC reserves the right to reject any of Contractor's employees whose qualifications and/or experience in ARRC's good faith and reasonable judgment do not meet the standards necessary for the performance of the services required under this contract.

## APPENDIX H

### REQUIRED CONTRACT PROVISIONS FOR FEDERAL-AID CONTRACTS [Revised June 9, 2017]

The following contract provisions shall apply, where applicable, to all work performed on the contract by the contractor's own organization and by subcontractors. As provided in this Section, the contractor shall insert in each subcontract all of the stipulations contained in these Required Contract Provisions and further require their inclusion in any lower tier subcontracts or purchase orders that may in turn be made. Incorporation by reference shall not be allowed. The prime contractor shall be responsible for compliance by any subcontractor or lower tier subcontractor with all applicable Required Contract Provisions.

**1. CARGO PREFERENCE REQUIREMENTS - 46 USC 55305; 46 CFR Part 381** [Applicable to all Federal-aid contracts involving equipment, materials or commodities which may be transported by ocean vessel]

**Cargo Preference-Use of United States Flag Vessels** - The contractor agrees: **a. to use** privately owned United States-Flag commercial vessels to ship at least 50 percent of the gross tonnage (computed separately for dry bulk carriers, dry cargo liners, and tankers) involved, whenever shipping any equipment, material, or commodities pursuant to the underlying contract to the extent such vessels are available at fair and reasonable rates for United States-Flag commercial vessels; **b. to furnish** within twenty (20) working days following the date of loading for shipments originating within the United States or within thirty (30) working days following the date of loading for shipments originating outside the United States, a legible copy of a rated, "on-board" commercial ocean bill-of-lading in English for each shipment of cargo described in the preceding subsection to the Division of National Cargo, Office of Market Development, Maritime Administration, Washington, DC 20590 and to ARRC (through the contractor in the case of a subcontractor's bill-of-lading.) **c. to include these** requirements in all subcontracts issued pursuant to this contract when the subcontract may involve the transport of equipment, material, or commodities by ocean vessel.

**2. DEBARMENT, SUSPENSION, INELIGIBILITY & VOLUNTARY EXCLUSION - 2 CFR Part 180 & Part 1200; 2 CFR 200.213; Executive Orders 12549 & 12689** [Applicable to all Federal-aid contracts which exceed \$25,000]

The Contractor shall comply and facilitate compliance with U.S. DOT regulations, "Non-procurement Suspension and Debarment," 2 CFR Part 1200, which adopts and supplements the U.S. Office of Management and Budget (U.S. OMB) "Guidelines to Agencies on Government-wide Debarment and Suspension (Non-procurement)," 2 CFR Part 180. As such, the Contractor shall verify that its principals, affiliates, and subcontractors are eligible to participate in this federally funded contract and are not presently declared by any Federal department or agency to be:

- a) Debarred from participation in any federally assisted Award;
- b) Suspended from participation in any federally assisted Award;
- c) Proposed for debarment from participation in any federally assisted Award;
- d) Declared ineligible to participate in any federally assisted Award;
- e) Voluntarily excluded from participation in any federally assisted Award; or
- f) Disqualified from participation in any federally assisted Award.

**By signing this contract and/or submitting its bid or proposal, the Contractor, bidder or proposer certifies as follows:**

The certification in this clause is a material representation of fact relied upon by the ARRC. If it is later determined by the ARRC that the Contractor, bidder or proposer knowingly rendered an erroneous certification, in addition to remedies available to the ARRC, the Federal Government may pursue available remedies, including but not limited to suspension and/or debarment. The Contractor, bidder or proposer agrees to comply with the requirements of 2 CFR Part 180, subpart C, as supplemented by 2 CFR Part 1200, while its offer is valid and throughout the period of any

contract that may arise from its offer. The contractor, bidder or proposer further agrees to include a provision requiring such compliance in its lower tier covered transactions.

**3. DAVIS-BACON AND COPELAND ANTI-KICKBACK ACTS - 40 USC 3141-3148; 49 USC 5333(a); 29 CFR Part 5; 2 CFR Part 200, App. II (D) [Applicable to all Federal-aid construction contracts which exceed \$2,000]**

**(1) Minimum wages** - (i) All laborers and mechanics employed or working upon the site of the work (or under the United States Housing Act of 1937 or under the Housing Act of 1949 in the construction or development of the project), will be paid unconditionally and not less often than once a week, and without subsequent deduction or rebate on any account (except such payroll deductions as are permitted by regulations issued by the Secretary of Labor under the Copeland Act (29 CFR part 3)), the full amount of wages and bona fide fringe benefits (or cash equivalents thereof) due at time of payment computed at rates not less than those contained in the wage determination of the Secretary of Labor which is attached hereto and made a part hereof, regardless of any contractual relationship which may be alleged to exist between the contractor and such laborers and mechanics.

Contributions made or costs reasonably anticipated for bona fide fringe benefits under section 1(b)(2) of the Davis-Bacon Act on behalf of laborers or mechanics are considered wages paid to such laborers or mechanics, subject to the provisions of paragraph (1)(iv) of this section; also, regular contributions made or costs incurred for more than a weekly period (but not less often than quarterly) under plans, funds, or programs which cover the particular weekly period, are deemed to be constructively made or incurred during such weekly period. Such laborers and mechanics shall be paid the appropriate wage rate and fringe benefits on the wage determination for the classification of work actually performed, without regard to skill, except as provided in 29 CFR Part 5.5(a)(4). Laborers or mechanics performing work in more than one classification may be compensated at the rate specified for each classification for the time actually worked therein: Provided, That the employer's payroll records accurately set forth the time spent in each classification in which work is performed. The wage determination (including any additional classifications and wage rates conformed under paragraph (1)(ii) of this section) and the Davis-Bacon poster (WH-1321) shall be posted at all times by the contractor and its subcontractors at the site of the work in a prominent and accessible place where it can be easily seen by the workers.

(ii)(A) The contracting officer shall require that any class of laborers or mechanics, including helpers, which is not listed in the wage determination and which is to be employed under the contract shall be classified in conformance with the wage determination. The contracting officer shall approve an additional classification and wage rate and fringe benefits therefore only when the following criteria have been met:

(1) Except with respect to helpers as defined as 29 CFR 5.2(n)(4), the work to be performed by the classification requested is not performed by a classification in the wage determination; and

(2) The classification is utilized in the area by the construction industry; and

(3) The proposed wage rate, including any bona fide fringe benefits, bears a reasonable relationship to the wage rates contained in the wage determination; and

(4) With respect to helpers as defined in 29 CFR 5.2(n)(4), such a classification prevails in the area in which the work is performed.

(B) If the contractor and the laborers and mechanics to be employed in the classification (if known), or their representatives, and the contracting officer agree on the classification and wage rate (including the amount designated for fringe benefits where appropriate), a report of the action taken shall be sent by the contracting officer to the Administrator of the Wage and Hour Division, Employment Standards Administration, U.S. Department of Labor, Washington, DC 20210. The Administrator, or an authorized representative, will approve, modify, or disapprove every additional classification action within 30 days of receipt and so advise the contracting officer or will notify the contracting officer within the 30-day period that additional time is necessary.

(C) In the event the contractor, the laborers or mechanics to be employed in the classification or their representatives, and the contracting officer do not agree on the proposed classification and wage rate (including the

amount designated for fringe benefits, where appropriate), the contracting officer shall refer the questions, including the views of all interested parties and the recommendation of the contracting officer, to the Administrator for determination. The Administrator, or an authorized representative, will issue a determination within 30 days of receipt and so advise the contracting officer or will notify the contracting officer within the 30-day period that additional time is necessary.

(D) The wage rate (including fringe benefits where appropriate) determined pursuant to paragraphs (a)(1)(ii) (B) or

(C) of this section, shall be paid to all workers performing work in the classification under this contract from the first day on which work is performed in the classification.

(iii) Whenever the minimum wage rate prescribed in the contract for a class of laborers or mechanics includes a fringe benefit which is not expressed as an hourly rate, the contractor shall either pay the benefit as stated in the wage determination or shall pay another bona fide fringe benefit or an hourly cash equivalent thereof.

(iv) If the contractor does not make payments to a trustee or other third person, the contractor may consider as part of the wages of any laborer or mechanic the amount of any costs reasonably anticipated in providing bona fide fringe benefits under a plan or program, Provided, That the Secretary of Labor has found, upon the written request of the contractor, that the applicable standards of the Davis-Bacon Act have been met. The Secretary of Labor may require the contractor to set aside in a separate account assets for the meeting of obligations under the plan or program.

(v)(A) The contracting officer shall require that any class of laborers or mechanics which is not listed in the wage determination and which is to be employed under the contract shall be classified in conformance with the wage determination. The contracting officer shall approve an additional classification and wage rate and fringe benefits therefore only when the following criteria have been met:

(1) The work to be performed by the classification requested is not performed by a classification in the wage determination; and

(2) The classification is utilized in the area by the construction industry; and

(3) The proposed wage rate, including any bona fide fringe benefits, bears a reasonable relationship to the wage rates contained in the wage determination.

(B) If the contractor and the laborers and mechanics to be employed in the classification (if known), or their representatives, and the contracting officer agree on the classification and wage rate (including the amount designated for fringe benefits where appropriate), a report of the action taken shall be sent by the contracting officer to the Administrator of the Wage and Hour Division, Employment Standards Administration, Washington, DC 20210. The Administrator, or an authorized representative, will approve, modify, or disapprove every additional classification action within 30 days of receipt and so advise the contracting officer or will notify the contracting officer within the 30-day period that additional time is necessary.

(C) In the event the contractor, the laborers or mechanics to be employed in the classification or their representatives, and the contracting officer do not agree on the proposed classification and wage rate (including the amount designated for fringe benefits, where appropriate), the contracting officer shall refer the questions, including the views of all interested parties and the recommendation of the contracting officer, to the Administrator for determination. The Administrator, or an authorized representative, will issue a determination with 30 days of receipt and so advise the contracting officer or will notify the contracting officer within the 30-day period that additional time is necessary.

(D) The wage rate (including fringe benefits where appropriate) determined pursuant to paragraphs (a)(1)(v) (B) or

(C) of this section, shall be paid to all workers performing work in the classification under this contract from the first day on which work is performed in the classification.

**(2) Withholding** - ARRC shall upon its own action or upon written request of an authorized representative of the Department of Labor withhold or cause to be withheld from the contractor under this contract or any other Federal contract with the same prime contractor, or any other federally-assisted contract subject to Davis-Bacon prevailing wage requirements, which is held by the same prime contractor, so much of the accrued payments or advances as may be considered necessary to pay laborers and mechanics, including apprentices, trainees, and helpers, employed by the contractor or any subcontractor the full amount of wages required by the contract. In the event of failure to pay any laborer or mechanic, including any apprentice, trainee, or helper, employed or working on the site of the work (or under the United States Housing Act of 1937 or under the Housing Act of 1949 in the construction or development of the project), all or part of the wages required by the contract, ARRC may, after written notice to the contractor, sponsor, applicant, or owner, take such action as may be necessary to cause the suspension of any further payment, advance, or guarantee of funds until such violations have ceased.

**(3) Payrolls and basic records** - (i) Payrolls and basic records relating thereto shall be maintained by the contractor during the course of the work and preserved for a period of three years thereafter for all laborers and mechanics working at the site of the work (or under the United States Housing Act of 1937, or under the Housing Act of 1949, in the construction or development of the project). Such records shall contain the name, address, and social security number of each such worker, his or her correct classification, hourly rates of wages paid (including rates of contributions or costs anticipated for bona fide fringe benefits or cash equivalents thereof of the types described in section 1(b)(2)(B) of the Davis-Bacon Act), daily and weekly number of hours worked, deductions made and actual wages paid. Whenever the Secretary of Labor has found under 29 CFR 5.5(a)(1)(iv) that the wages of any laborer or mechanic include the amount of any costs reasonably anticipated in providing benefits under a plan or program described in section 1(b)(2)(B) of the Davis-Bacon Act, the contractor shall maintain records which show that the commitment to provide such benefits is enforceable, that the plan or program is financially responsible, and that the plan or program has been communicated in writing to the laborers or mechanics affected, and records which show the costs anticipated or the actual cost incurred in providing such benefits. Contractors employing apprentices or trainees under approved programs shall maintain written evidence of the registration of apprenticeship programs and certification of trainee programs, the registration of the apprentices and trainees, and the ratios and wage rates prescribed in the applicable programs.

(ii)(A) The contractor shall submit weekly for each week in which any contract work is performed a copy of all payrolls to ARRC for transmission to the Federal grantor agency. The payrolls submitted shall set out accurately and completely all of the information required to be maintained under section 5.5(a)(3)(i) of Regulations, 29 CFR part 5. This information may be submitted in any form desired. Optional Form WH-347 is available for this purpose and may be purchased from the Superintendent of Documents (Federal Stock Number 029-005-00014-1), U.S. Government Printing Office, Washington, DC 20402. The prime contractor is responsible for the submission of copies of payrolls by all subcontractors.

(B) Each payroll submitted shall be accompanied by a "Statement of Compliance," signed by the contractor or subcontractor or his or her agent who pays or supervises the payment of the persons employed under the contract and shall certify the following:

(1) That the payroll for the payroll period contains the information required to be maintained under section 5.5(a)(3)(i) of Regulations, 29 CFR part 5 and that such information is correct and complete;

(2) That each laborer or mechanic (including each helper, apprentice, and trainee) employed on the contract during the payroll period has been paid the full weekly wages earned, without rebate, either directly or indirectly, and that no deductions have been made either directly or indirectly from the full wages earned, other than permissible deductions as set forth in Regulations, 29 CFR part 3;

(3) That each laborer or mechanic has been paid not less than the applicable wage rates and fringe benefits or cash equivalents for the classification of work performed, as specified in the applicable wage determination incorporated into the contract.

(C) The weekly submission of a properly executed certification set forth on the reverse side of Optional Form WH-347 shall satisfy the requirement for submission of the "Statement of Compliance" required by paragraph (a)(3)(ii)(B) of this section.

(D) The falsification of any of the above certifications may subject the contractor or subcontractor to civil or criminal prosecution under section 1001 of title 18 and section 231 of title 31 of the United States Code.

(iii) The contractor or subcontractor shall make the records required under paragraph (a)(3)(i) of this section available for inspection, copying, or transcription by authorized representatives of the Federal grantor agency or the Department of Labor, and shall permit such representatives to interview employees during working hours on the job. If the contractor or subcontractor fails to submit the required records or to make them available, the Federal agency may, after written notice to the contractor, sponsor, applicant, or owner, take such action as may be necessary to cause the suspension of any further payment, advance, or guarantee of funds. Furthermore, failure to submit the required records upon request or to make such records available may be grounds for debarment action pursuant to 29 CFR 5.12.

**(4) Apprentices and trainees - (i) Apprentices** - Apprentices will be permitted to work at less than the predetermined rate for the work they performed when they are employed pursuant to and individually registered in a bona fide apprenticeship program registered with the U.S. Department of Labor, Employment and Training Administration, Bureau of Apprenticeship and Training, or with a State Apprenticeship Agency recognized by the Bureau, or if a person is employed in his or her first 90 days of probationary employment as an apprentice in such an apprenticeship program, who is not individually registered in the program, but who has been certified by the Bureau of Apprenticeship and Training or a State Apprenticeship Agency (where appropriate) to be eligible for probationary employment as an apprentice. The allowable ratio of apprentices to journeymen on the job site in any craft classification shall not be greater than the ratio permitted to the contractor as to the entire work force under the registered program. Any worker listed on a payroll at an apprentice wage rate, who is not registered or otherwise employed as stated above, shall be paid not less than the applicable wage rate on the wage determination for the classification of work actually performed. In addition, any apprentice performing work on the job site in excess of the ratio permitted under the registered program shall be paid not less than the applicable wage rate on the wage determination for the work actually performed. Where a contractor is performing construction on a project in a locality other than that in which its program is registered, the ratios and wage rates (expressed in percentages of the journeyman's hourly rate) specified in the contractor's or subcontractor's registered program shall be observed. Every apprentice must be paid at not less than the rate specified in the registered program for the apprentice's level of progress, expressed as a percentage of the journeymen hourly rate specified in the applicable wage determination. Apprentices shall be paid fringe benefits in accordance with the provisions of the apprenticeship program. If the apprenticeship program does not specify fringe benefits, apprentices must be paid the full amount of fringe benefits listed on the wage determination for the applicable classification. If the Administrator of the Wage and Hour Division of the U.S. Department of Labor determines that a different practice prevails for the applicable apprentice classification, fringes shall be paid in accordance with that determination. In the event the Bureau of Apprenticeship and Training, or a State Apprenticeship Agency recognized by the Bureau, withdraws approval of an apprenticeship program, the contractor will no longer be permitted to utilize apprentices at less than the applicable predetermined rate for the work performed until an acceptable program is approved.

(ii) **Trainees** - Except as provided in 29 CFR 5.16, trainees will not be permitted to work at less than the predetermined rate for the work performed unless they are employed pursuant to and individually registered in a program which has received prior approval, evidenced by formal certification by the U.S. Department of Labor, Employment and Training Administration. The ratio of trainees to journeymen on the job site shall not be greater than permitted under the plan approved by the Employment and Training Administration. Every trainee must be paid at not less than the rate specified in the approved program for the trainee's level of progress, expressed as a percentage of the journeyman hourly rate specified in the applicable wage determination. Trainees shall be paid fringe benefits in accordance with the provisions of the trainee program. If the trainee program does not mention fringe benefits, trainees shall be paid the full amount of fringe benefits listed on the wage determination unless the Administrator of the Wage and Hour Division determines that there is an apprenticeship program associated with the corresponding journeyman wage rate on the wage determination which provides for less than full fringe benefits for apprentices. Any employee listed on the payroll at a trainee rate who is not registered and participating in a training plan approved by the Employment and Training Administration shall be paid not less than the applicable wage rate on the wage determination for the classification of work actually performed. In addition, any trainee performing work on the job

site in excess of the ratio permitted under the registered program shall be paid not less than the applicable wage rate on the wage determination for the work actually performed. In the event the Employment and Training Administration withdraws approval of a training program, the contractor will no longer be permitted to utilize trainees at less than the applicable predetermined rate for the work performed until an acceptable program is approved.

(iii) Equal employment opportunity - The utilization of apprentices, trainees and journeymen under this part shall be in conformity with the equal employment opportunity requirements of Executive Order 11246, as amended, and 29 CFR part 30.

(5) **Compliance with Copeland Act requirements** - The contractor shall comply with the requirements of 29 CFR Part 3, which are incorporated by reference in this contract.

(6) **Subcontracts** - The contractor or subcontractor shall insert in any subcontracts the clauses contained in 29 CFR 5.5(a)(1) through (10) and such other clauses as the Federal Transit Administration may by appropriate instructions require, and also a clause requiring the subcontractors to include these clauses in any lower tier subcontracts. The prime contractor shall be responsible for the compliance by any subcontractor or lower tier subcontractor with all the contract clauses in 29 CFR 5.5.

(7) **Contract termination: debarment** - A breach of the contract clauses in 29 CFR 5.5 may be grounds for termination of the contract, and for debarment as a contractor and a subcontractor as provided in 29 CFR 5.12.

(8) **Compliance with Davis-Bacon and Related Act requirements** - All rulings and interpretations of the Davis-Bacon and Related Acts contained in 29 CFR parts 1, 3, and 5 are herein incorporated by reference in this contract.

(9) **Disputes concerning labor standards** - Disputes arising out of the labor standards provisions of this contract shall not be subject to the general disputes clause of this contract. Such disputes shall be resolved in accordance with the procedures of the Department of Labor set forth in 29 CFR parts 5, 6, and 7. Disputes within the meaning of this clause include disputes between the contractor (or any of its subcontractors) and the contracting agency, the U.S. Department of Labor, or the employees or their representatives.

(10) **Certification of eligibility** - (i) By entering into this contract, the contractor certifies that neither it (nor he or she) nor any person or firm who has an interest in the contractor's firm is a person or firm ineligible to be awarded Government contracts by virtue of section 3(a) of the Davis-Bacon Act or 29 CFR 5.12(a)(1).

(ii) No part of this contract shall be subcontracted to any person or firm ineligible for award of a Government contract by virtue of section 3(a) of the Davis-Bacon Act or 29 CFR 5.12(a)(1).

(iii) The penalty for making false statements is prescribed in the U.S. Criminal Code, 18 USC 1001.

4. **CONTRACT WORK HOURS AND SAFETY STANDARDS ACT - 40 USC 3701-3708.; 29 CFR Part 5; 29 CFR 1926; 2 CFR Part 200, App. II (E)** [Applicable to all Federal-aid construction in excess of \$100,000 and all nonconstruction contracts which employ mechanics and laborers on a public work in excess of \$100,000]

A. **Overtime** (Applicable to construction and nonconstruction contracts)

(1) **Overtime requirements** - No contractor or subcontractor contracting for any part of the contract work which may require or involve the employment of laborers or mechanics shall require or permit any such laborer or mechanic in any workweek in which he or she is employed on such work to work in excess of forty hours in such workweek unless such laborer or mechanic receives compensation at a rate not less than one and one-half times the basic rate of pay for all hours worked in excess of forty hours in such workweek.

(2) **Violation; liability for unpaid wages; liquidated damages** - In the event of any violation of the clause set forth in paragraph (1) of this section the contractor and any subcontractor responsible therefore shall be liable for the unpaid wages. In addition, such contractor and subcontractor shall be liable to the United States for liquidated damages. Such liquidated damages shall be computed with respect to each individual laborer or mechanic, including



watchmen and guards, employed in violation of the clause set forth in paragraph (1) of this section, in the sum of \$10 for each calendar day on which such individual was required or permitted to work in excess of the standard workweek of forty hours without payment of the overtime wages required by the clause set forth in paragraph (1) of this section.

**(3) Withholding for unpaid wages and liquidated damages** - ARRC shall upon its own action or upon written request of an authorized representative of the Department of Labor withhold or cause to be withheld, from any moneys payable on account of work performed by the contractor or subcontractor under any such contract or any other Federal contract with the same prime contractor, or any other federally-assisted contract subject to the Contract Work Hours and Safety Standards Act, which is held by the same prime contractor, such sums as may be determined to be necessary to satisfy any liabilities of such contractor or subcontractor for unpaid wages and liquidated damages as provided in the clause set forth in paragraph (2) of this section.

**(4) Subcontracts** - The contractor or subcontractor shall insert in any subcontracts the clauses set forth in this section and also a clause requiring the subcontractors to include these clauses in any lower tier subcontracts. The prime contractor shall be responsible for compliance by any subcontractor or lower tier subcontractor with the clauses set forth in this section.

**(5) Payrolls and basic records** - (i) Payrolls and basic records relating thereto shall be maintained by the contractor during the course of the work and preserved for a period of three years thereafter for all laborers and mechanics working at the site of the work. Such records shall contain the name, address, and social security number of each such worker, his or her correct classification, hourly rates of wages paid (including rates of contributions or costs anticipated for bona fide fringe benefits or cash equivalents thereof of the types described in section 1(b)(2)(B) of the Davis-Bacon Act), daily and weekly number of hours worked, deductions made and actual wages paid. Whenever the Secretary of Labor has found under 29 CFR 5.5(a)(1)(iv) that the wages of any laborer or mechanic include the amount of any costs reasonably anticipated in providing benefits under a plan or program described in section 1(b)(2)(B) of the Davis-Bacon Act, the contractor shall maintain records which show that the commitment to provide such benefits is enforceable, that the plan or program is financially responsible, and that the plan or program has been communicated in writing to the laborers or mechanics affected, and records which show the costs anticipated or the actual cost incurred in providing such benefits. Contractors employing apprentices or trainees under approved programs shall maintain written evidence of the registration of apprenticeship programs and certification of trainee programs, the registration of the apprentices and trainees, and the ratios and wage rates prescribed in the applicable programs.

**B. Contract Work Hours and Safety Standards Act** (Applicable to construction contracts only) (i) The Contractor agrees to comply with section 107 of the Contract Work Hours and Safety Standards Act, 40 USC § 333, and applicable DOL regulations, "Safety and Health Regulations for Construction" 29 CFR Part 1926. Among other things, the Contractor agrees that it will not require any laborer or mechanic to work in unsanitary, hazardous, or dangerous surroundings or working conditions.

(ii) **Subcontracts** - The Contractor also agrees to include the requirements of this section in each subcontract. The term "subcontract" under this section is considered to refer to a person who agrees to perform any part of the labor or material requirements of a contract for construction, alteration or repair. A person who undertakes to perform a portion of a contract involving the furnishing of supplies or materials will be considered a "subcontractor" under this section if the work in question involves the performance of construction work and is to be performed: (1) directly on or near the construction site, or (2) by the employer for the specific project on a customized basis. Thus, a supplier of materials which will become an integral part of the construction is a "subcontractor" if the supplier fabricates or assembles the goods or materials in question specifically for the construction project and the work involved may be said to be construction activity. If the goods or materials in question are ordinarily sold to other customers from regular inventory, the supplier is not a "subcontractor." The requirements of this section do not apply to contracts or subcontracts for the purchase of supplies or materials or articles normally available on the open market.

**5. FEDERAL WATER POLLUTION CONTROL ACT- 33 USC 1251-1387; 2 CFR Part 200, App. II (G)**  
[Applicable to all Federal-aid contracts which exceed \$150,000]

(1) The Contractor agrees to comply with all applicable standards, orders or regulations issued pursuant to the Federal Water Pollution Control Act, as amended, 33 USC 1251 et seq. The Contractor agrees to report each violation to

ARRC and understands and agrees that ARRC will, in turn, report each violation as required to assure notification to the Federal grantor agency and the appropriate EPA Regional Office. (2) The Contractor also agrees to include these requirements in each subcontract exceeding \$150,000 financed in whole or in part with Federal funds.

**6. CLEAN AIR ACT - 42 USC 7401-7671q; 2 CFR Part 200, App. II (G) [Applicable to all Federal-aid contracts which exceed \$150,000]**

(1) The Contractor agrees to comply with all applicable standards, orders or regulations issued pursuant to the Clean Air Act, as amended, 42 USC 7401 et seq. The Contractor agrees to report each violation to ARRC and understands and agrees that ARRC will, in turn, report each violation as required to assure notification to the Federal grantor agency and the appropriate EPA Regional Office. (2) The Contractor also agrees to include these requirements in each subcontract exceeding \$150,000 financed in whole or in part with Federal funds.

**7. ACCESS TO RECORDS AND REPORTS – 49 USC 5325(g); 2 CFR 200.333; 49 CFR Part 633** [Applicable to all Federal-aid contracts]

Access to Records - The following access to records requirements apply to this Contract:

1. Contractor agrees to provide ARRC, the Federal grantor agency, the Comptroller General, or any of their duly authorized representatives access to the Contractor's books, documents, papers and records which are directly pertinent to this contract for the purpose of making audit, examination, excerpts and transcriptions.

2. Contractor agrees to permit any of the foregoing parties to reproduce by any means whatsoever or to copy excerpts and transcriptions as reasonably needed.

3. Contractor agrees to comply with the record retention requirements in accordance with 2 CFR 200.333. Contractor agrees to maintain all books, records, accounts and reports required under this contract for a period of not less than three years after the date of termination or expiration of this contract, except in the event of litigation or settlement of claims arising from the performance of this contract, in which case Contractor agrees to maintain the same until ARRC, the Federal grantor agency, the Comptroller General, or any of their duly authorized representatives, have disposed of all such litigation, appeals, claims or exceptions related thereto.

4. Contractor agrees to permit the Federal grantor agency and its contractors access to the sites of performance under this contract as reasonably may be required.

5. Contractor agrees to include these requirements in each subcontract financed in whole or in part with Federal funds.

**8. CHANGES TO FEDERAL REQUIREMENTS – [Applicable to all Federal-aid contracts]**

**Federal Changes** - Contractor shall at all times comply with all applicable Federal regulations, policies, procedures and directives, including without limitation those listed directly or by reference in the Agreement between ARRC and the Federal grantor agency, as they may be amended or promulgated from time to time during the term of this contract. Contractor's failure to so comply shall constitute a material breach of this contract.

**9. NO GOVERNMENT OBLIGATION TO THIRD PARTIES [Applicable to all Federal-aid contracts]**

(1) ARRC and Contractor acknowledge and agree that, notwithstanding any concurrence by the Federal Government in or approval of the solicitation or award of the underlying contract, absent the express written consent by the Federal Government, the Federal Government is not a party to this contract and shall not be subject to any obligations or liabilities to ARRC, Contractor, or any other party (whether or not a party to that contract) pertaining to any matter resulting from the underlying contract.

(2) The Contractor agrees to include the above clause in each subcontract financed in whole or in part with Federal assistance. It is further agreed that the clause shall not be modified, except to identify the subcontractor who will be subject to its provisions.

**10. PROGRAM FRAUD AND FALSE OR FRAUDULENT STATEMENTS AND RELATED ACTS – 49 USC 5323j(1); 31 USC 3801-3812; 49 CFR Part 31; 18 USC 1001 [Applicable to all Federal-aid contracts]**

(1) The Contractor acknowledges that the provisions of the Program Fraud Civil Remedies Act of 1986, as amended, 31 USC §3801 et seq. and U.S. DOT regulations, "Program Fraud Civil Remedies," 49 CFR Part 31, apply to its actions pertaining to this Project. Upon execution of the underlying contract, the Contractor certifies or affirms the truthfulness and accuracy of any statement it has made, it makes, it may make, or causes to be made, pertaining to the underlying contract or the Federally assisted project for which this contract work is being performed. In addition to other penalties that may be applicable, the Contractor further acknowledges that if it makes, or causes to be made, a false, fictitious, or fraudulent claim, statement, submission, or certification, the Federal Government reserves the right to impose the penalties of the Program Fraud Civil Remedies Act of 1986 on the Contractor to the extent the Federal Government deems appropriate.

(2) The Contractor also acknowledges that if it makes, or causes to be made, a false, fictitious, or fraudulent claim, statement, submission, or certification to the Federal Government under a contract connected with a project that is financed in whole or in part with Federal assistance, the Government reserves the right to impose the penalties of 18 USC §1001 and 49 USC 5323(l) on the Contractor, to the extent the Federal Government deems appropriate.

(3) The Contractor agrees to include the above two clauses in each subcontract financed in whole or in part with Federal assistance. It is further agreed that the clauses shall not be modified, except to identify the subcontractor who will be subject to the provisions.

**11. SEISMIC SAFETY REQUIREMENTS - 42 USC 7701 et seq. & 49 CFR Part 41; Executive Order 12699 [Applicable only to Federal-aid contracts for the construction of new buildings or additions to existing buildings]**

**Seismic Safety** - The contractor agrees that any new building or addition to an existing building will be designed and constructed in accordance with the standards for Seismic Safety required in Department of Transportation Seismic Safety Regulations, 49 CFR Part 41 and will certify to compliance to the extent required by the regulation. The contractor also agrees to ensure that all work performed under this contract including work performed by a subcontractor is in compliance with the standards required by the Seismic Safety Regulations and the certification of compliance issued on the project.

**12. ENERGY CONSERVATION REQUIREMENTS - 42 USC 6321 et seq. & 49 CFR Part 622, Subpart C [Applicable to all Federal-aid contracts]**

**Energy Conservation** - The Contractor agrees to comply with mandatory standards and policies relating to energy efficiency which are contained in the state energy conservation plan issued in compliance with the Energy Policy and Conservation Act.

**13. CIVIL RIGHTS AND EQUAL OPPORTUNITY REQUIREMENTS – 49 USC 5332; 29 USC 623, 42 USC 2000e, 42 USC 6102, 42 USC 12112, 42 USC 12132, 29 CFR Part 1630, & 41 CFR Parts 60 et seq. [Applicable to all Federal-aid contracts]**

**Civil Rights** - The following requirements apply to the underlying contract:

1. Nondiscrimination - In accordance with 49 USC 5332 and Title VI of the Civil Rights Act, as amended, 42 USC 2000e, section 303 of the Age Discrimination Act of 1975, as amended, 42 USC 6102, and section 202 of the Americans with Disabilities Act of 1990, 42 USC 12132, the Contractor agrees that it will not discriminate against any employee or applicant for employment because of race, color, creed, national origin, sex, age, or disability. In addition, the Contractor agrees to comply with applicable Federal implementing regulations and other implementing requirements the Federal grantor agency may issue.

2. Equal Employment Opportunity - The following equal employment opportunity requirements apply to the underlying contract:

(a) Race, Color, Creed, National Origin, Sex - In accordance with 49 USC 5332 and Title VII of the Civil Rights Act, as amended, and 42 USC §2000e, the Contractor agrees to comply with all applicable equal employment opportunity requirements of U.S. Department of Labor (U.S. DOL) regulations, "Office of Federal Contract Compliance Programs, Equal Employment Opportunity, Department of Labor," 41 CFR Parts 60 et seq., (which implement Executive Order No. 11246, "Equal Employment Opportunity," as amended by Executive Order No. 11375, "Amending Executive Order 11246 Relating to Equal Employment Opportunity," 42 USC 2000e note), and with any applicable Federal statutes, executive orders, regulations, and Federal policies that may in the future affect construction activities undertaken in the course of the Project. The Contractor agrees to take affirmative action to ensure that applicants are employed, and that employees are treated during employment, without regard to their race, color, creed, national origin, sex, or age. Such action shall include, but not be limited to, the following: employment, upgrading, demotion or transfer, recruitment or recruitment advertising, layoff or termination; rates of pay or other forms of compensation; and selection for training, including apprenticeship. In addition, the Contractor agrees to comply with any implementing requirements the Federal grantor agency may issue.

(b) Age - In accordance with the Age Discrimination in Employment Act, 29 USC 621-634, U.S. Equal Employment Opportunity Commission (U.S. EEOC) regulations, "Age Discrimination in Employment Act," 29 CFR Part 1625, the Age Discrimination Act of 1975, as amended, 42 USC 6101 *et seq.*, U.S. Health and Human Services regulations, "Nondiscrimination on the Basis of Age in Programs or Activities Receiving Federal Financial Assistance," 45 CFR Part 90, and 49 USC 5332, the Contractor agrees to refrain from discrimination against present and prospective employees for reason of age. In addition, the Contractor agrees to comply with any implementing requirements Federal grantor agency may issue.

(c) Disabilities - In accordance with section 504 of the Rehabilitation Act of 1973, as amended, 29 USC 794, the Americans with Disabilities Act of 1990, as amended, 42 USC 12101 *et seq.*, the Architectural Barriers Act of 1968, as amended, 42 USC 4151 *et seq.*, and 49 USC 5332, the Contractor agrees that it will not discriminate against individuals on the basis of disability. In addition, the Contractor agrees to comply with any implementing requirements the Federal grantor agency may issue.

3. The Contractor also agrees to include these requirements in each subcontract financed in whole or in part with Federal assistance, modified only if necessary to identify the affected parties.

**14. VIOLATION AND BREACH OF CONTRACT - 2 CFR 200.326; 2 CFR Part 200, App. II(A)**  
[Applicable to all Federal-aid contracts in excess of \$150,000]

#### **Rights and Remedies of the ARRC**

Except as may be otherwise provided in the contract documents, in the event that ARRC deems the contractor guilty of a default or breach of any provision under the Contract, ARRC shall have any and all rights and remedies provided by applicable law, including, but not limited to the following:

1. The right to take over and complete the work or any part thereof as agent for and at the expense of the Contractor, either directly or through other contractors;
2. The right to cancel this Contract as to any or all of the work yet to be performed;
3. The right to specific performance, an injunction or any other appropriate equitable remedy; and
4. The right to money damages.

#### **Rights and Remedies of Contractor**

Inasmuch as the Contractor can be adequately compensated by money damages for any breach of this Contract, which may be committed by the ARRC, the Contractor expressly agrees that no default, act or omission of the ARRC shall constitute a material breach of this Contract, entitling Contractor to cancel or rescind the Contract (unless the ARRC directs Contractor to do so) or to suspend or abandon performance. Contractor claims or disputes arising in the performance of this Contract which are not resolved by agreement of the parties shall be decided in accordance with ARRC's Procurement Rules.

**Performance During Dispute** - Unless otherwise directed by ARRC, Contractor shall continue performance under this contract while matters in dispute are being resolved.

**Notification** - In addition to the notice requirements set out elsewhere in this Contract, if the contractor becomes aware of any act or occurrence which may form the basis of a claim by the contractor for additional compensation or an extension of time for performance, or if any dispute arises regarding a question of fact or interpretation of the contract, the contractor shall immediately inform the Project Manager. If the matter cannot be resolved by agreement within 7 days, the contractor shall, within the next 14 days, submit an Intent to Claim in writing to the Project Manager. The claim, if not resolved, shall be presented to the Project Manager, in writing, within 60 days following receipt of the Intent to Claim. Receipt of the claim will be acknowledged in writing by the Project Manager. The Contractor agrees that unless these written notices are provided, the contractor will have no entitlement to additional time or compensation for such act, event or condition.

**Presenting Claim** - A claim shall be submitted in accordance with ARRC Procurement Rule 1800.12 and shall specifically include the following:

1. The act, event or condition giving rise to the claim.
2. The contract provisions which apply to the claim and under which relief is provided.
3. The item or items of contract work affected and how they are affected.
4. The specific relief requested, including additional contract time if applicable, and the basis upon which it was calculated.

**Claim Validity, Additional Information, & Project Manager's Actions** - The claim, in order to be valid, must not only show that the contractor suffered damages or delay but that those conditions were actually a result of the act, event or condition complained of and that the contract provides entitlement to relief to the contractor for such act, event, or condition. The Project Manager reserves the right to make written request to the contractor at any time for additional information which the contractor may possess relative to the claim. The contractor agrees to provide the Project Manager such additional information within 30 days of receipt of such a request. Failure to furnish such additional information may be regarded as a waiver of the claim. The claim, if not resolved by agreement within 60 days of its receipt, will automatically be forwarded to the Manager of Purchasing & Materials for formal written decision.

**Decision on Claim** - The contractor will be furnished the Manager of Purchasing & Materials' decision within the next 90 days, unless additional information is requested by the ARRC. The Manager of Purchasing & Materials' decision is final and conclusive unless fraudulent as to the Claim.

**Notice of Appeal** - Within 14 days of receipt of the Manager of Purchasing & Materials' decision, the contractor may deliver a Notice of Appeal to ARRC in accordance with ARRC Procurement Rule 1800.13 and request a hearing. The Notice of Appeal shall include specific exceptions to the Manager of Purchasing & Materials' decision, including specific provisions of the contract, which the contractor intends to rely upon in the appeal. General assertions that the Manager of Purchasing & Materials' decision is contrary to law or to fact are not sufficient.

**Decision on Appeal** - The decision of the ARRC on appeal will be rendered within 90 days after the conclusion of a hearing conducted under ARRC Procurement Rule 1800.15 or the date of receipt of the Notice of Appeal, whichever is later. The time limits given above may be extended by mutual consent. The decision of ARRC on appeal shall be final and conclusive unless the Contractor appeals to the superior court in accordance with ARRC Procurement Rule 1800.18.

**15. NONSEGREGATED FACILITIES** [Applicable to all Federal-aid construction contracts and to all related subcontracts of \$10,000 or more]

1. By submission of this bid, the execution of this contract or subcontract, or the consummation of this material supply agreement or purchase order, as appropriate, the bidder, Federal-aid construction contractor, subcontractor, material supplier, or vendor, as appropriate, certifies that the firm does not maintain or provide for its employees any segregated facilities at any of its establishments, and that the firm does not permit its employees to perform their services at any location, under its control, where segregated facilities are maintained. The firm agrees that a breach of

this certification is a violation of the EEO Provisions of this contract. The firm further certifies that no employee will be denied access to adequate facilities on the basis of sex or disability.

2. As used in this certification, the term “segregated facilities” means any waiting rooms, work areas, restrooms and washrooms, restaurants and other eating areas, timeclocks, locker rooms and other storage or dressing areas, parking lots, drinking fountains, recreation or entertainment areas, transportation, and housing facilities provided for employees which are segregated by explicit directive, or are, in fact, segregated on the basis of race, color, religion, or national origin, age or disability, because of habit, local custom, or otherwise. The only exception will be for the disabled when the demands for accessibility override (e.g. disabled parking).

3. The contractor agrees that it has obtained or will obtain identical certification from proposed subcontractors or material suppliers prior to the award of subcontracts or consummation of material supply agreements of \$10,000 or more and that it will retain such certifications in its files.

**16. NATIONAL HISTORIC PRESERVATION ACT REQUIREMENTS - 16 USC 470 et seq. [Applicable to all Federal-Aid contracts]**

In the performance of this contract, neither Contractor nor its subcontractors shall take any action (which term includes but is not limited to the seeking of any required federal license or permit, and the extraction of material or natural resources from any source whatsoever) that may affect a district, site, building, structure or object that is included in or eligible for inclusion in the National Register of Historic Places without prior notice to ARRC and compliance with the requirements of the National Historic Preservation Act of 1966, 16 USC 470 et seq. Contractor is advised that both historic and cultural sites may be eligible for inclusion on the National Register.

**17. FLY AMERICA REQUIREMENT - 49 USC 40118; 41 CFR 301-10 [Applicable to all Federal-aid contracts which may involve the international air transportation of equipment, materials, commodities, products or personnel]**

a) *Definitions.* As used in this clause--

“International air transportation” means transportation by air between a place in the United States and a place outside the United States or between two places both of which are outside the United States

“United States” means the 50 States, the District of Columbia, and outlying areas.

“U.S.-flag air carrier” means an air carrier holding a certificate under 49 U.S.C. Chapter 411.

b) When Federal funds are used to fund travel, Section 5 of the International Air Transportation Fair Competitive Practices Act of 1974 (49 USC 40118) (Fly America Act) requires contractors, recipients, and others use U.S.-flag air carriers for U.S. Government-financed international air transportation of personnel (and their personal effects) or property, to the extent that service by those carriers is available. It requires the Comptroller General of the United States, in the absence of satisfactory proof of the necessity for foreign-flag air transportation, to disallow expenditures from funds, appropriated or otherwise established for the account of the United States, for international air transportation secured aboard a foreign-flag air carrier if a U.S.-flag air carrier is available to provide such services.

c) If available, the Contractor, in performing work under this contract, shall use U.S.-flag carriers for international air transportation of personnel (and their personal effects) or property.

d) In the event that the Contractor selects a carrier other than a U.S.-flag air carrier for international air transportation, the Contractor shall include a statement on vouchers involving such transportation essentially as follows:

**Statement of Unavailability of U.S.-Flag Air Carriers**

International air transportation of persons (and their personal effects) or property by U.S.-flag air carrier was not available or it was necessary to use foreign-flag air carrier service for the following reasons. See FAR § 47.403. [*State reasons*]:

---

---

The Contractor agrees to include the requirements of this section in all subcontracts that may involve international air transportation.

**18. RECYCLED PRODUCTS - 42 USC 6962; 40 CFR PART 247; 2 CFR 200.322** [Applicable to all Federal-aid contracts for items designated by the EPA, for the purchase of \$10,000 or more of one of these items during the fiscal year]

The Contractor agrees to provide a preference for those products and services that conserve natural resources, protect the environment, and are energy efficient by complying with and facilitating compliance with Section 6002 of the Resource Conservation and Recovery Act, as amended, 42 USC 6962, and U.S. Environmental Protection Agency (U.S. EPA), "Comprehensive Procurement Guideline for Products Containing Recovered Materials," 40 CFR Part 247. The Contractor agrees to include these requirements in each subcontract financed in whole or in part with Federal funds.

**19. INCORPORATION OF FEDERAL TRANSIT ADMINISTRATION TERMS - FTA Circular 4220.1F** [Applicable to all FTA funded contracts]

The provisions herein include, in part, certain Standard Terms and Conditions required by USDOT, whether or not expressly set forth in the contract provisions. All contractual provisions required by USDOT, as set forth in FTA Circular 4220.1F are incorporated by reference. Anything to the contrary herein notwithstanding, all FTA mandated terms shall be deemed to control in the event of a conflict with other provisions contained in this agreement. The contractor shall not perform any act, fail to perform any act, or refuse to comply with any ARRC requests which would cause ARRC to be in violation of the FTA terms and conditions.

**20. DISADVANTAGED BUSINESS ENTERPRISE (DBE) PROGRAM - 49 CFR Part 26.** [Applicable to all FTA and FHWA funded contracts]

**1. Assurance** - The contractor or subcontractor shall not discriminate on the basis of race, color, national origin, or sex in the performance of this contract. The contractor shall carry out applicable requirements of 49 CFR Part 26 in the award and administration of U.S. Department of Transportation-assisted contracts. Failure by the contractor to carry out these requirements is a material breach of this contract, which may result in the termination of this contract or such other remedy as the ARRC deems appropriate, which may include, but is not limited to:

- (1) Withholding monthly progress payments;
- (2) Assessing sanctions;
- (3) Liquidated damages; and/or
- (4) Disqualifying the contractor from future bidding as non-responsible. 49 CFR 26.13(b).

**2. Contract Goal** – ARRC runs a completely race-neutral DBE program. Accordingly, this contract has no specific contract goal for the participation of Disadvantaged Business Enterprises (DBEs). ARRC does have an overall annual goal that it strives to meet, however. The ARRC therefore strongly encourages the contractor to use the services of small businesses, including DBEs, as subcontractors whenever possible. The ARRC requests that the contractor consider such measures as: (1) subcontracting to small businesses, including DBEs, portions of the work the contractor might otherwise do with its own forces; (2) reducing or waiving subcontractor bonding requirements for small businesses, including DBEs; (3) reviewing the list of businesses certified in the Small Business Administration's 8(a) Business Development Program for potential subcontractors [contact the SBA at (907) 271-4022]; and (4) reviewing the list of businesses certified as DBEs by the Alaska Unified Certification Program for potential subcontractors [<http://www.dot.state.ak.us/cvlrts/directory.shtml>].

**3. Prompt Payment** - The prime contractor agrees to pay each subcontractor under this prime contract for satisfactory performance of its contract no later than thirty (30) days from the receipt of each payment the prime contractor receives from the ARRC. The prime contractor agrees further to return retainage payments to each subcontractor within thirty (30) days after the subcontractor's work is satisfactorily completed, even if the prime

contractor's work has not been completed. Any retainage not returned to a subcontractor will be reported to the ARRC by the prime contractor. This clause applies to both DBE and non-DBE subcontractors.

**21. FHWA BUY AMERICA REQUIREMENTS - 23 CFR 635.410** [Applicable only to FHWA funded construction contracts in excess of \$150,000]

Unless a waiver has been granted by the FHWA, all steel and iron materials which are incorporated into the work, and the action of applying a coating to a covered material (i.e., steel and iron), shall be manufactured in the United States except that minor amounts of steel and iron materials of foreign manufacture may be used, provided the aggregate cost of such materials does not exceed one tenth of one percent (0.1 percent) of the total contract amount, or \$2500, whichever is greater. Coating includes epoxy coating, galvanizing, painting, and any other coating that protects or enhances the value of a material subject to the requirements of this section. For the purposes of this section, the cost is the value of the products as they are delivered to the project. When steel and iron materials manufactured in the United States are shipped to a foreign country where non-steel or iron products are installed on or in them (i.e., electronic components in a steel cabinet), the steel and iron is considered to meet the requirements of this section. A certification of materials origin, attesting to compliance with this provision, shall be furnished to the Engineer prior to incorporating any steel or iron products into the project. Bidders may submit an alternate bid for the project based on the use of foreign iron or steel materials. In this event, the contract will be awarded to the bidder who submits the lowest total responsive bid based on furnishing domestic iron and steel materials unless such total bid exceeds the lowest total responsive bid based on furnishing foreign steel and iron materials by more than 25 percent.

**Certificate of Compliance with 23 CFR 635.410**

The bidder or offeror hereby certifies that it will comply with the requirements of 23 CFR 635.410.

Date: \_\_\_\_\_

Signature: \_\_\_\_\_

Company Name: \_\_\_\_\_

Title: \_\_\_\_\_



22. **FTA BUY AMERICA REQUIREMENTS - 49 USC 5323(j); 49 CFR Part 661** [Applicable only to FTA funded projects that involve the purchase of more than \$150,000 of iron, steel, manufactured goods or rolling stock]

**Buy America** - The contractor agrees to comply with 49 USC 5323(j) and 49 CFR Part 661, which provide that Federal funds may not be obligated unless all steel, iron, and manufactured products used in FTA-funded projects are produced in the United States, unless a waiver has been granted by FTA or the product is subject to a general waiver. General waivers are listed in 49 CFR 661.7. Separate requirements for rolling stock are set out at 49 USC 5323(j)(2)(C) and 49 CFR 661.11.

A bidder or offeror must submit to the ARRC the appropriate Buy America certification (below) with all bids or offers on FTA-funded contracts, except those subject to a general waiver. Bids or offers that are not accompanied by a completed Buy America certification must be rejected as nonresponsive.

**Certification requirement for procurement of steel, iron, or manufactured products:**

**Certificate of Compliance with 49 USC 5323(j)(1)**

The bidder or offeror hereby certifies that it will meet the requirements of 49 USC 5323(j)(1) and the applicable regulations in 49 CFR Part 661.6.

Date: \_\_\_\_\_  
Signature: \_\_\_\_\_  
Company Name: \_\_\_\_\_  
Title: \_\_\_\_\_

**Certificate of Non-Compliance with 49 USC 5323(j)(1)**

The bidder or offeror hereby certifies that it cannot comply with the requirements of 49 USC 5323(j) and 49 CFR 661.6, but it may qualify for an exception pursuant to 49 USC 5323(j)(2)(A), 5323(j)(2), as amended, and the applicable regulations in 49 CFR 661.7.

Date: \_\_\_\_\_  
Signature: \_\_\_\_\_  
Company Name: \_\_\_\_\_  
Title: \_\_\_\_\_

**Certification requirement for procurement of rolling stock and associated equipment:**

**Certificate of Compliance with 49 USC 5323(j)**

The bidder or offeror hereby certifies that it will comply with the requirements of 49 USC 5323(j) and the regulations at 49 CFR 661.11.

Date: \_\_\_\_\_  
Signature: \_\_\_\_\_  
Company Name: \_\_\_\_\_  
Title: \_\_\_\_\_

**Certificate of Non-Compliance with 49 USC 5323(j)**

The bidder or offeror hereby certifies that it cannot comply with the requirements of 49 USC 5323(j) and 49 CFR 661.11, but may qualify for an exception pursuant to 49 USC 5323(j)(2)(C), and the applicable regulations at 49 CFR 661.7.

Date: \_\_\_\_\_  
Signature: \_\_\_\_\_  
Company Name: \_\_\_\_\_  
Title: \_\_\_\_\_

23. **FRA BUY AMERICA REQUIREMENTS-SUPPLIES - 41 USC 10a-d; 48 CFR Part 25** [Applicable only to FRA funded contracts for the purchase of goods, supplies or equipment in excess of \$150,000]

(a) The FRA requires its grantees to comply with The Buy American Act (41 U.S.C. 10) which provides that preference be given to domestic end products.

*Components*, as used in this clause, means those articles, materials, and supplies incorporated directly into the end products.

*Domestic end product*, as used in this clause, means (1) an unmanufactured end product mined or produced in the United States, or (2) an end product manufactured in the United States, if the cost of its components mined, produced, or manufactured in the United States exceeds 50 percent of the cost of all its components. Components of foreign origin of the same class or kind as the products referred to in subparagraphs (b) (2) or (3) of this clause shall be treated as domestic. Scrap generated, collected, and prepared for processing in the United States is considered domestic.

*End products*, as used in this clause, means those articles, materials, and supplies to be acquired for public use under this contract.

(b) The Contractor shall deliver only domestic end products, except those-

(1) For use outside the United States;

(2) That government agencies have determined are not mined, produced, or manufactured in the United States in sufficient and reasonably available commercial quantities of a satisfactory quality. A current list of such items is contained in 48 CFR 25.108.

(3) For which the agency determines that domestic preference would be inconsistent with the public interest; or

(4) For which the agency determines the cost to be unreasonable under 48 CFR 25.105. The offered price of a domestic end product shall be determined to be unreasonable when the lowest acceptable domestic offer exceeds the lowest acceptable foreign offer, inclusive of duty, by more than 6 percent, if the domestic offer is from a large business or more than 12 percent, if the domestic offer is from a small business concern.

A bidder must submit to ARRC the Buy America certification (below) with its bid response for FRA funded supply contracts. Bids that are not accompanied by a completed Buy America certification may be rejected as nonresponsive.

**Certificate of Compliance with 41 USC 10a-d - Supplies**

The bidder or offeror hereby certifies that the products it proposes to supply hereunder comply with the requirements of 49 USC 10a-d and the applicable regulations in 48 CFR Part 25.

Date: \_\_\_\_\_

Signature: \_\_\_\_\_

Company Name: \_\_\_\_\_

Title: \_\_\_\_\_

**24. FRA BUY AMERICA REQUIREMENT-CONSTRUCTION - 41 USC 10a-d; 48 CFR Part 25**  
[Applicable only to FRA funded construction contracts in excess of \$150,000]

(a) The FRA requires its grantees to comply with The Buy American Act (41 U.S.C. 10) which provides that preference be given to domestic construction materials. As used in this clause-

*Components* means those articles, materials, and supplies incorporated directly into construction materials.

*Construction material* means an article, material, or supply brought to the construction site for incorporation into the building or work. Construction material also includes an item brought to the site pre-assembled from articles, materials, or supplies. However, emergency life safety systems, such as emergency lighting, fire alarm, and audio evacuation systems, which are discrete systems incorporated into a public building or work and which are produced as a complete system, shall be evaluated as a single and distinct construction material regardless of when or how the individual parts or components of such systems are delivered to the construction site.

*Domestic construction material* means (1) an unmanufactured construction material mined or produced in the United States, or (2) a construction material manufactured in the U.S., if the cost of its components mined, produced, or manufactured in the United States exceeds 50 percent of cost of all its components. Materials of foreign origin of the same class or kind as the materials listed in 48 CFR 25.108 shall be treated as domestic.

(b)(1) The Buy American Act (41 USC 10a-10d) requires that only domestic construction material be used in performing this contract, except as provided in paragraphs (b)(2) and (b)(3) of this clause.

(2) The requirement in paragraph (b)(1) of this clause does not apply to the excepted construction materials or components listed by the Government as follows: NONE

(3) Other foreign construction material may be used on this project if ARRC determines that-

(i) The cost would be unreasonable (the cost of a particular domestic construction material shall be determined to be unreasonable when the cost of such material exceeds the cost of foreign material by more than 6 percent, unless the agency head determines a higher percentage to be appropriate);

(ii) The application of the restriction of the Buy American Act to a particular construction material would be impracticable or inconsistent with the public interest; or

(iii) The construction material is not mined, produced, or manufactured in the United States in sufficient and reasonably available commercial quantities of a satisfactory quality.

(4) The Contractor agrees that only domestic construction materials will be used by the Contractor, subcontractors, material men, and suppliers in the performance of this contract, except for foreign construction materials, if any, listed in paragraph (b)(2) or allowed under paragraph (b)(3) of this clause.

(c) *Request for determination.* (1) Contractors requesting to use foreign construction material under paragraph (b)(3) of this clause shall provide adequate information for ARRC evaluation of the request for a determination regarding the inapplicability of the Buy American Act in time to allow determination before submission of bids or offers. Each submission shall include a description of the foreign and domestic construction materials, including unit of measure, quantity, price, time of delivery or availability, location of the construction project, name and address of the proposed contractor, and a detailed justification of the reason for use of foreign materials cited in accordance with paragraph (b)(3) of this clause. A submission based on unreasonable cost shall include a reasonable survey of the market and a completed price comparison table in the format in paragraph (d) of this clause. The price of construction material shall include all delivery costs to the construction site and any applicable duty (whether or not a duty-free certificate may be issued).

(2) If ARRC determines after contract award that an exception to the Buy American Act applies, the contract shall be modified to allow use of the foreign construction material, and adequate consideration shall be negotiated. However,

when the basis for the exception is the unreasonable price of a domestic construction material, adequate consideration shall not be less than the differential established in paragraph (b)(3)(i) of this clause.

(3) If ARRC does not determine that an exception to the Buy American Act applies, the use of that particular foreign construction material will be a failure to comply with the Act.

(d) For evaluation of requests under paragraph (c) of this clause based on unreasonable cost, the following information and any applicable supporting data based on the survey of suppliers shall be included in the request:

**FOREIGN AND DOMESTIC CONSTRUCTION  
MATERIALS PRICE COMPARISON**

Construction material description	Unit of Measure	Quantity	Price (Dollars) <sup>1/</sup>
Item 1: Foreign construction material Domestic construction material			
Item 2: Foreign construction material Domestic construction material			

List name, address, telephone number, and contact for suppliers surveyed. Attach copy of response; if oral, attach summary. Include other applicable supporting information.

<sup>1/</sup>Include all delivery costs to the construction site and any applicable duty (whether or not a duty- free entry certificate is issued).

A bidder must submit to ARRC the Buy America certification (below) with its bid response for FRA funded construction. Bids that are not accompanied by a completed Buy America certification may be rejected as nonresponsive.

**Certificate of Compliance with 41 USC 10a-d - Construction**

The bidder or offeror hereby certifies that the construction materials it proposes to provide hereunder comply with the requirements of 49 USC 10a-d and the applicable regulations in 48 CFR Part 25.

Date: \_\_\_\_\_

Signature: \_\_\_\_\_

Company Name: \_\_\_\_\_

Title: \_\_\_\_\_

**25. CERTIFICATION REGARDING USE OF CONTRACT FUNDS FOR LOBBYING - 31 USC 1352; 2 CFR 200.450; 2 CFR 200 App. II(j); 49 CFR Part 20 [Applicable to all Federal-aid contracts and to all related subcontracts which exceed \$100,000]**

A bidder must submit to ARRC the below certification with its bid response for any Federally funded contract that exceeds \$100,000. Bids that are not accompanied by a completed certification may be rejected as nonresponsive.

1. The undersigned Contractor certifies, to the best of his or her knowledge and belief, that:
  - a. No Federal appropriated funds have been paid or will be paid, by or on behalf of the undersigned, to any person for influencing or attempting to influence an officer or employee of any Federal agency, a Member of Congress, an officer or employee of Congress, or an employee of a Member of Congress in connection with the awarding of any Federal contract, the making of any Federal grant, the making of any Federal loan, the entering into of any cooperative agreement, and the extension, continuation, renewal, amendment, or modification of any Federal contract, grant, loan, or cooperative agreement.
  - b. If any funds other than Federal appropriated funds have been paid or will be paid to any person for influencing or attempting to influence an officer or employee of any Federal agency, a Member of Congress, an officer or employee of Congress, or an employee of a Member of Congress in connection with this Federal contract, grant, loan, or cooperative agreement, the undersigned shall complete and submit Standard Form-LLL, "Disclosure Form to Report Lobbying," in accordance with its instructions.
2. The undersigned also agrees that he or she shall require that the language of this certification be included in all lower tier subcontracts, which exceed \$100,000 and that all such recipients shall certify and disclose accordingly.
3. This certification is a material representation of fact upon which reliance was placed when this transaction was made or entered into. Submission of this certification is a prerequisite for making or entering into this transaction imposed by 31 USC 1352 (as amended by the Lobbying Disclosure Act of 1995). Any person who fails to file the required certification shall be subject to a civil penalty of not less than \$10,000 and not more than \$100,000 for each such failure.

The Contractor, \_\_\_\_\_ certifies or affirms the truthfulness and accuracy of each statement of its certification and disclosure, if any. In addition, the Contractor understands and agrees that the provisions of 31 USC 3801, *et seq.*, apply to this certification and disclosure, if any.

Signature of Contractor's Authorized Official: \_\_\_\_\_

Name and Title of Contractor's Authorized Official: \_\_\_\_\_

Date: \_\_\_\_\_

**26. FTA PRE-AWARD AND POST DELIVERY AUDITS REQUIREMENTS - 49 USC 5323; 49 CFR Part 663 [Applicable only to FTA funded contracts for the purchase of rolling stock in excess of \$150,000]**

**Pre-Award and Post-Delivery Audit Requirements** - The Contractor agrees to comply with 49 USC 5323(l) and FTA's implementing regulation at 49 CFR Part 663 and to submit the following certifications:

(1) **Buy America Requirements:** The Contractor shall complete and submit a declaration certifying either compliance or noncompliance with Buy America. If the Bidder/Offeror certifies compliance with Buy America, it shall submit documentation which lists 1) component and subcomponent parts of the rolling stock to be purchased identified by manufacturer of the parts, their country of origin and costs; and 2) the location of the final assembly point for the rolling stock, including a description of the activities that will take place at the final assembly point and the cost of final assembly.

(2) **Solicitation Specification Requirements:** The Contractor shall submit evidence that it will be capable of meeting the bid specifications.

(3) **Federal Motor Vehicle Safety Standards (FMVSS):** The Contractor shall submit 1) manufacturer's FMVSS self-certification sticker information that the vehicle complies with relevant FMVSS or 2) manufacturer's certified statement that the contracted buses will not be subject to FMVSS regulations.

**27. CERTIFICATION REGARDING COMPLIANCE WITH 49 CFR 26.49 - ESTABLISHMENT OF DBE GOAL [Applicable to all FTA funded contracts for Transit Vehicles]**

**Certificate of Compliance with 49 CFR 26.49**

The bidder or offeror hereby certifies that it has established a DBE goal and submitted it to the FTA for approval in accordance with the provisions of 49 CFR 26.49.

Date: \_\_\_\_\_

Signature: \_\_\_\_\_

Company Name: \_\_\_\_\_

Title: \_\_\_\_\_

**28. SAFE OPERATION OF MOTOR VEHICLES - 23 USC Part 402; Executive Order No. 13043; Executive Order No. 13513; U.S. DOT Order No. 3902.10 [Applicable to all federally funded third party contracts]**

**Seat Belt Use** - The Contractor is encouraged to adopt and promote on-the-job seat belt use policies and programs for its employees and other personnel that operate company-owned vehicles, company-rented vehicles, or personally operated vehicles. The terms "company-owned" and "company-leased" refer to vehicles owned or leased either by the Contractor or ARRC.

**Distracted Driving** - The Contractor agrees to adopt and enforce workplace safety policies to decrease crashes caused by distracted drivers, including policies to ban text messaging while using an electronic device supplied by an employer, and driving a vehicle the driver owns or rents, a vehicle Contractor owns, leases, or rents, or a privately-owned vehicle when on official business in connection with the work performed under this agreement.

**29. PATENT RIGHTS - 2 CFR Part 200, App. II(F); 37 CFR Part 401 [Applicable all federally funded contracts with a small business firm or nonprofit organization for the performance of experimental, developmental or research work]**

This Project is funded through a Federal award for experimental, developmental, or research work purposes. As such, certain Patent Rights and Data Rights apply to all subject data first produced in the performance of this contract. The Contractor shall grant the ARRC intellectual property access and licenses deemed necessary for the work performed

under this contract and in accordance with the requirements of 37 CFR Part 401, "Rights to Inventions Made by Nonprofit Organizations and Small Business Firms Under Government Grants, Contracts and Cooperative Agreements," and any implementing regulations issued by the federal grantor agency. The terms of an intellectual property agreement and software license rights will be finalized prior to execution of this contract and shall, at a minimum, include the following restrictions: Except for its own internal use, the Contractor may not publish or reproduce subject data in whole or in part, or in any manner or form, nor may the Contractor authorize others to do so, without the written consent of ARRC and the federal grantor agency, until such time as they may have either released or approved the release of such data to the public. This restriction on publication, however, does not apply to any contract with an academic institution. For purposes of this agreement, the term "subject data" means recorded information whether or not copyrighted, and that is delivered or specified to be delivered as required by the contract. Examples of "subject data" include, but are not limited to computer software, standards, specifications, engineering drawings and associated lists, process sheets, manuals, technical reports, catalog item identifications, and related information, but do not include financial reports, cost analyses, or other similar information used for performance or administration of the Contract.

1. The Federal Government reserves a royalty-free, non-exclusive and irrevocable license to reproduce, publish, or otherwise use, and to authorize others to use for "Federal Government Purposes," any subject data or copyright described below. For "Federal Government Purposes," means use only for the direct purposes of the Federal Government. Without the copyright owner's consent, the Federal Government may not extend its Federal license to any other party.

(a) Any subject data developed under the contract, whether or not a copyright has been obtained; and

(b) Any rights of copyright purchased by the Contractor using Federal assistance in whole or in part by the federal grantor agency.

2. Unless the federal grantor agency determines otherwise, the Contractor performing experimental, developmental, or research work required as part of this contract agrees to permit the federal grantor agency to make available to the public, either its license in the copyright to any subject data developed in the course of the contract, or a copy of the subject data first produced under the contract for which a copyright has not been obtained. If the experimental, developmental, or research work, which is the subject of this contract, is not completed for any reason whatsoever, all data developed under the contract shall become subject data as defined herein and shall be delivered as the Federal Government may direct.

3. Unless prohibited by state law, upon request by the Federal Government, the Contractor agrees to indemnify, save, and hold harmless the Federal Government, its officers, agents, and employees acting within the scope of their official duties against any liability, including costs and expenses, resulting from any willful or intentional violation by the Contractor of proprietary rights, copyrights, or right of privacy, arising out of the publication, translation, reproduction, delivery, use, or disposition of any data furnished under that contract. The Contractor shall be required to indemnify the Federal Government for any such liability arising out of the wrongful act of any employee, official, or agents of the Federal Government.

4. Nothing contained in this clause on rights in data shall imply a license to the Federal Government under any patent or be construed as affecting the scope of any license or other right otherwise granted to the Federal Government under any patent.

5. Data developed by the Contractor and financed entirely without using Federal assistance provided by the Federal Government that has been incorporated into work required by the underlying contract is exempt from the requirements herein, provided that the Contractor identifies those data in writing at the time of delivery of the contract work.

6. The Contractor agrees to include these requirements in each subcontract for experimental, developmental, or research work financed in whole or in part with Federal assistance.

**30. MONITORING AND REPORTING PROGRAM PERFORMANCE – 2CFR Part 200.238**

**31. TERMINATION – 2 CFR 200.339; 2 CFR Part 200 App. II(B)** [Applicable to all federally funded contracts in excess of \$10,000]

Except as may be otherwise provided in the contract documents, the following termination provisions apply to this contract:

1. ARRC may, for its sole convenience, terminate this contract in whole or in part, at any time by giving written notice of its intention to do so. In the event of such termination, Contractor shall be entitled to receive payment in accordance with the payment provisions of this contract for charges incurred prior to the effective date of termination. Contractor shall not be paid for any work done after receipt of a notice of cancellation or for any costs incurred by Contractor's suppliers or subcontractors which Contractor could reasonably have avoided. In no event shall ARRC be liable for unabsorbed overhead or anticipatory profit on unperformed work.

2. In addition to ARRC's right to terminate this contract for its convenience, ARRC may, by written notice of default to Contractor, terminate the contract in whole or in part in the following circumstances:

(a) The Contractor refuses or fails to perform its obligations under the contract, or fails to make progress so as to significantly endanger timely completion or performance of the contract in accordance with its terms, and Contractor does not cure such default within a period of ten (10) days after receipt of written notice of default from ARRC or within such additional cure period as ARRC may authorize; or

(b) Reasonable grounds for insecurity arise with respect to Contractor's expected performance and Contractor fails to furnish adequate assurance of due performance (including assurance of performance in accordance with the time requirements of the contract) within ten (10) days after receipt of a written request by ARRC for adequate assurance; or

(c) Contractor becomes insolvent or makes an assignment for the benefit of creditors or commits an act of bankruptcy or files or has filed against it a petition in bankruptcy or reorganization proceedings.

3. Upon receipt of a notice of cancellation or termination, Contractor shall immediately discontinue all performance and it shall immediately cause any of its suppliers or subcontractors to cease such work unless the notice directs otherwise and deliver immediately to ARRC all products, reports, plans, drawings, specifications, data, summaries or other materials and information, whether completed or in process, accumulated by Contractor in performance of the contract. The rights and remedies of ARRC provided in this section shall not be exclusive and are in addition to any other rights and remedies provided by law.