

## ARR 301, 352 & 451/452 Seat Frame Trim Installation Instructions | ARRC 2022

Installation instructions for trim items for new and existing seat frames.

### ARR 301 SEAT FRAMES

1. Install seat frame edge trim, PN ARR-301-0001 using (5) 1/8" S.S. flush head blind rivets. Note, single frame shown, double frame has two of shown:

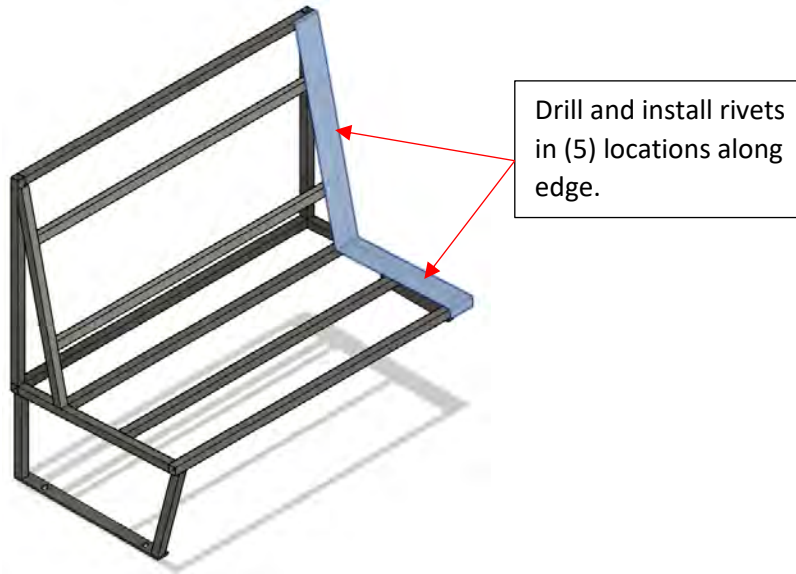

2. Install lower frame side trim, PN ARR-301-0002 using (6) #6 self-drilling S.S. sheet metal screws:

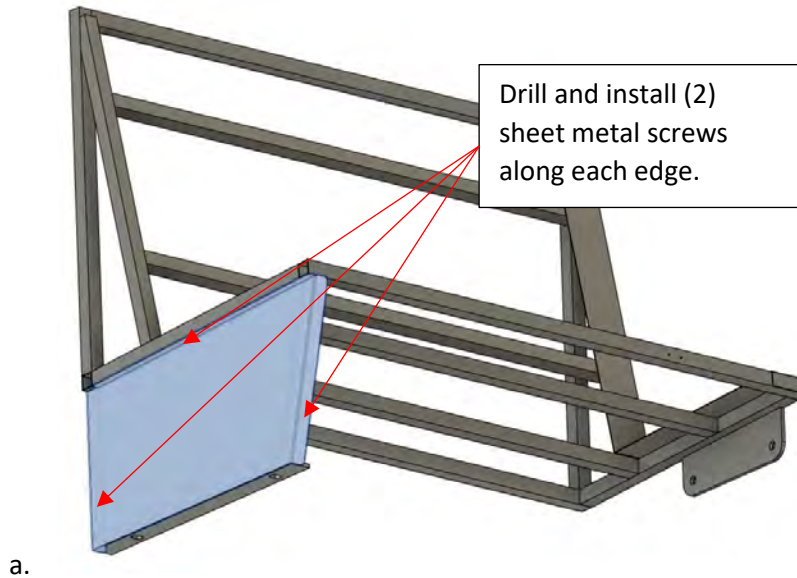

Double frame (install using (8) screws):

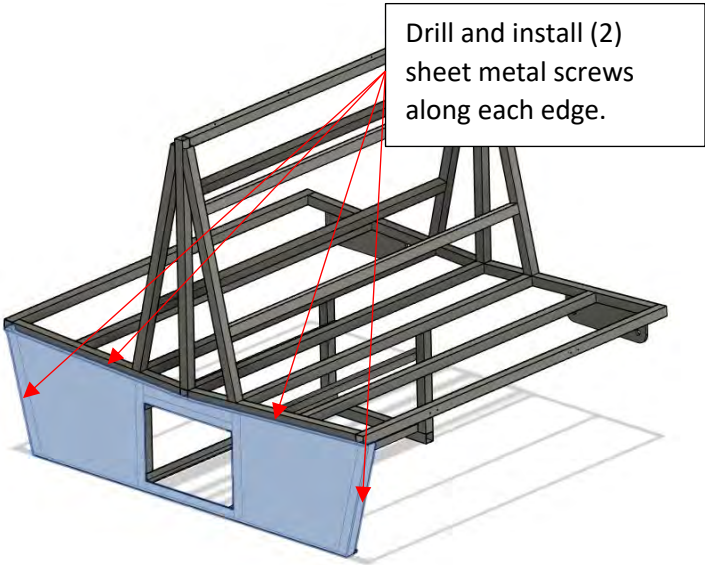

b.

3. Install upper frame side trim PN ARR-301-0012 using (6), #6x 1.25" S.S. dome head sheet metal screws:

a.

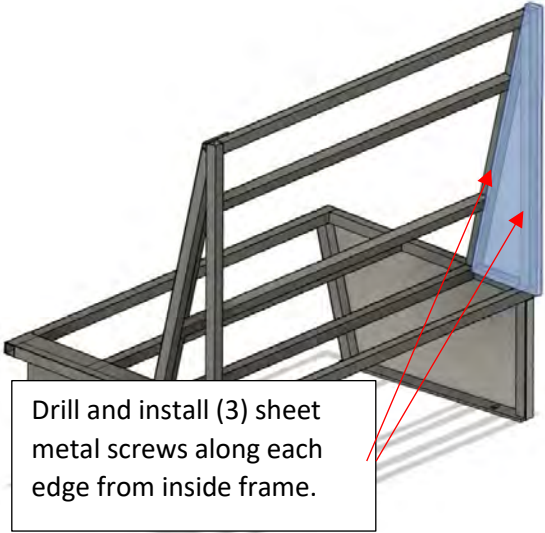

b.

Double Frame, PN ARR-301-0013:

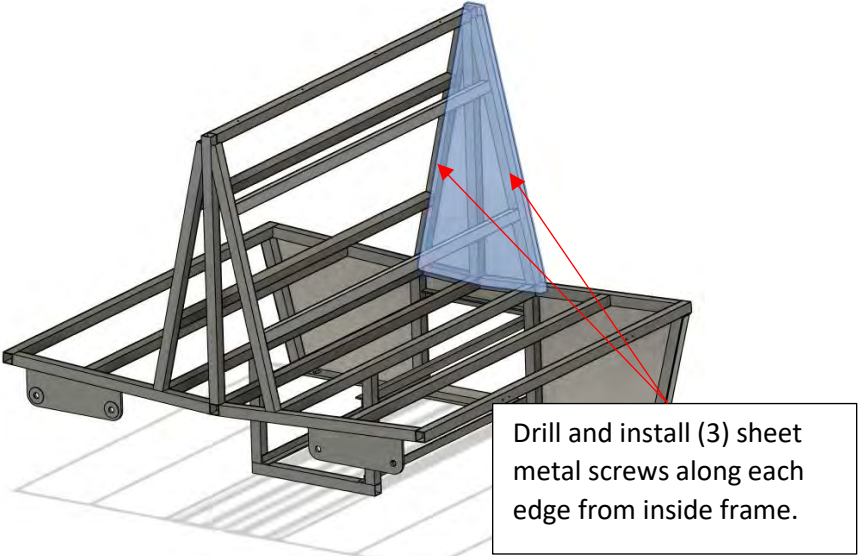

c.

- 4. Install divider rail, PN ARR-301-0010 using (4) #6x2" SS sheet metal screws installed from under side. Note, single frame shown, double frame uses PN ARR-301-0011:

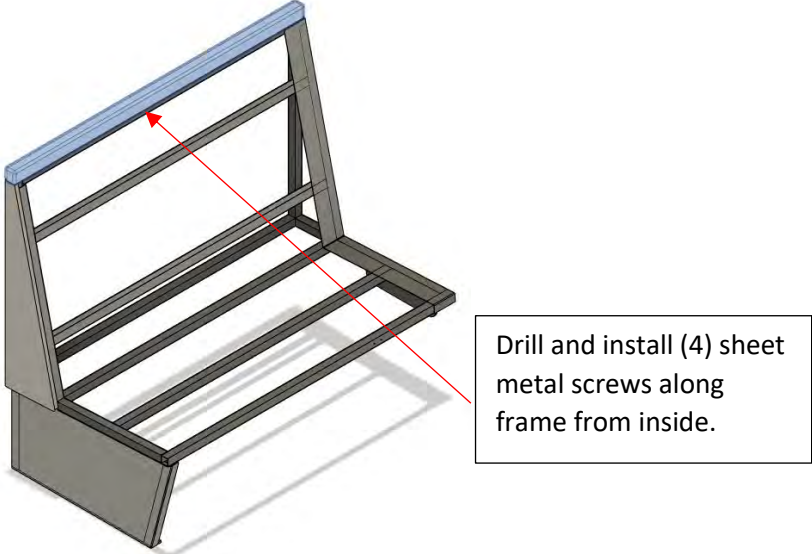

a.

- 5. Assemble and install double seat frame drawer (PN ARR-301-), drawer face (PN ARR-301-) and latch using (4) machine screws, washers and nuts:



a.

## ARR 352 SINGLE SEAT FRAME ASSEMBLY

1. Install back trim board, PN ARR-352-0010 using (9) #6x1.25" SS sheet metal screws, installed from inside frame:

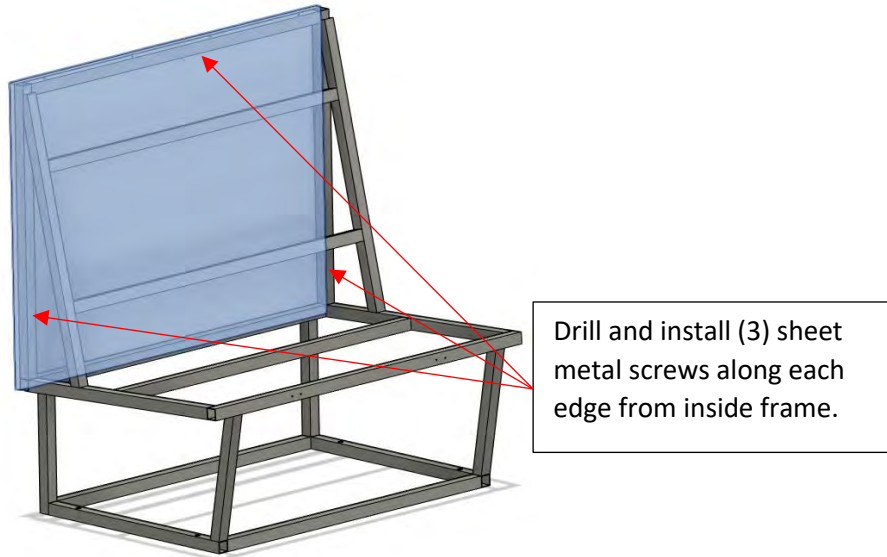

a.

2. Install lower back trim, PN ARR-352-0011 using (5) #6 self-drilling S.S. sheet metal screws:

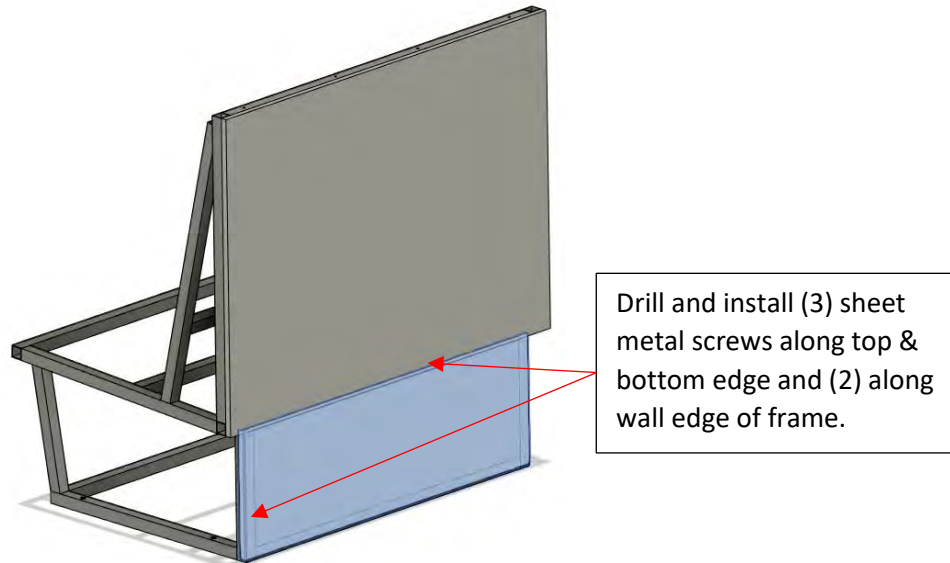

a.

3. Install lower side trim, PN ARR-352-0001 using (6) #6 self-drilling S.S. sheet metal screws:

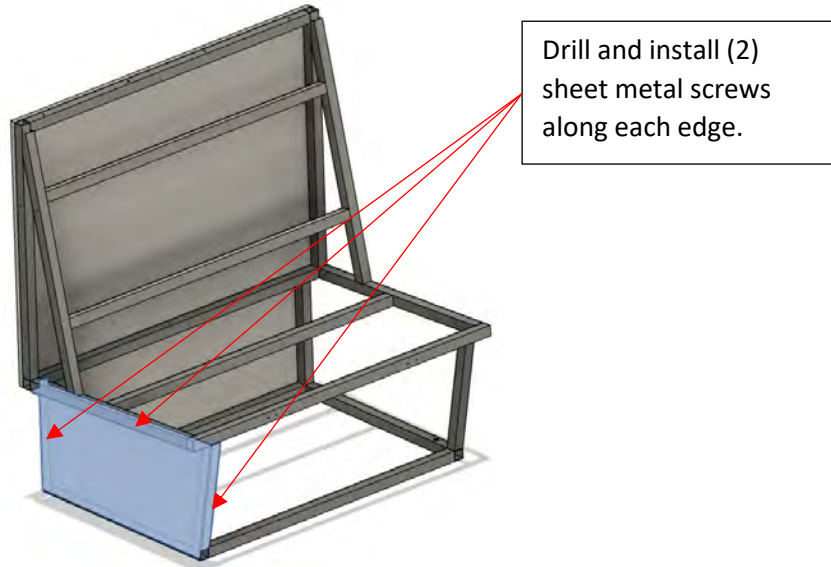

4. Install side trim board, PN ARR-352-0012 using (6), #6x 1.25" S.S. dome head sheet metal screws:

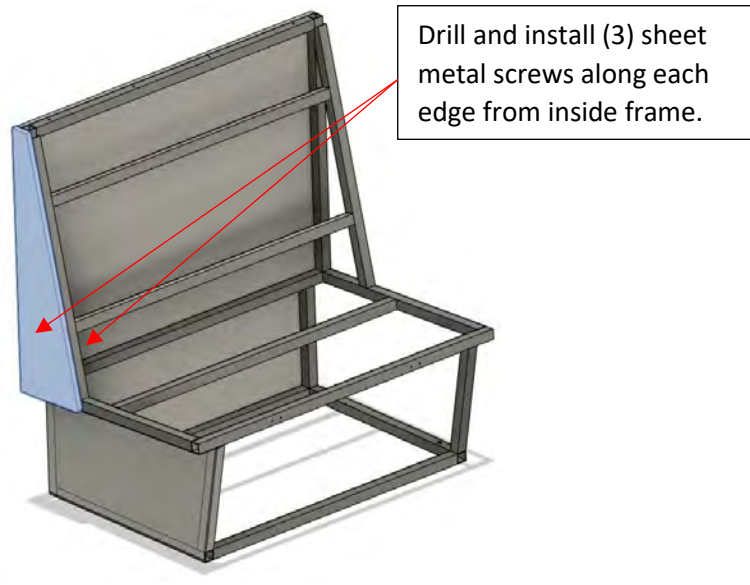



5. Install divider rail, PN ARR-352-0008 using (4) #6x2" SS sheet metal screws installed from under side:

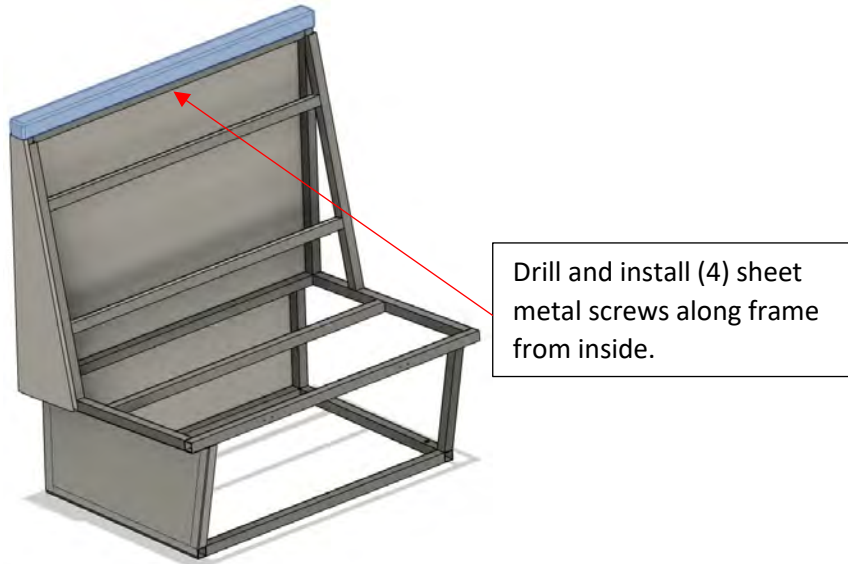

#### ARR 352 DOUBLE SEAT FRAME ASSEMBLY

1. Install lower side trim, PN ARR-352-0003 using (8) #6 self-drilling S.S. sheet metal screws:

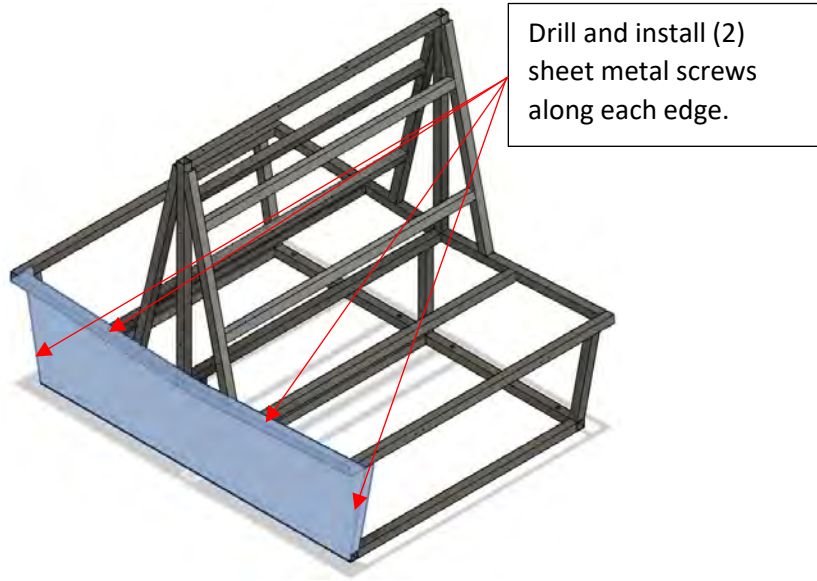

2. Install side trim board, PN ARR-352-0013 using (6), #6x 1.25" S.S. dome head sheet metal screws:

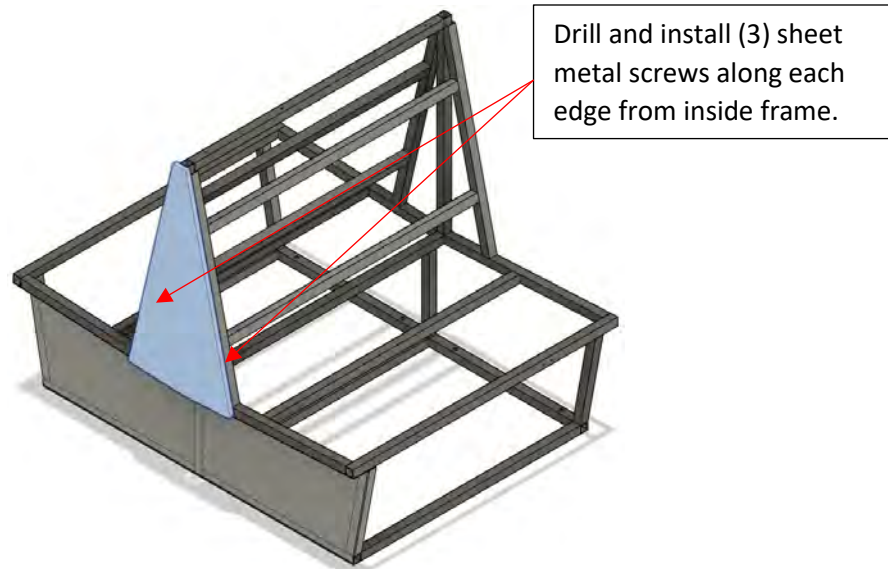

- a.
3. Install divider rail, PN ARR-352-0009 using (4) #6x2" SS sheet metal screws installed from under side:

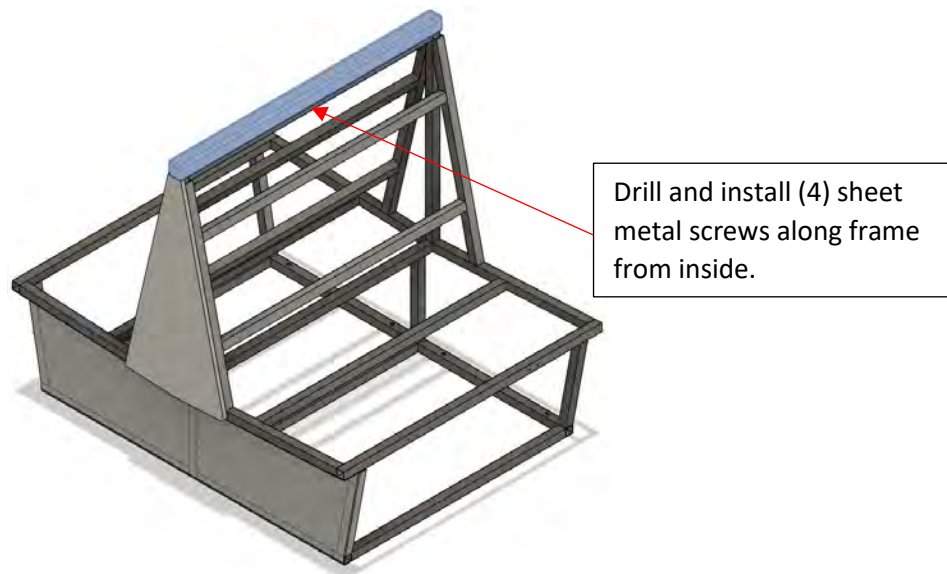

a.

## ARR 451 & 452 SEAT MODIFICATIONS AND TRIM INSTALLATION

1. Remove and discard all existing seat cushions and trim boards:



Remove seat cushions  
and lower trim boards.

a.

2. Drill out sheet metal divider rivets, both sides of dividers, remove and discard divider cover:



Drill out and  
remove rivets

a.



3. Drill out and remove rivets from both sides of seat frame top angle, remove and discard steel divider frame:



4. Install new seat frame top angle (ARRC provided) using (4) zinc-plated, 3/16" large head blind rivets:

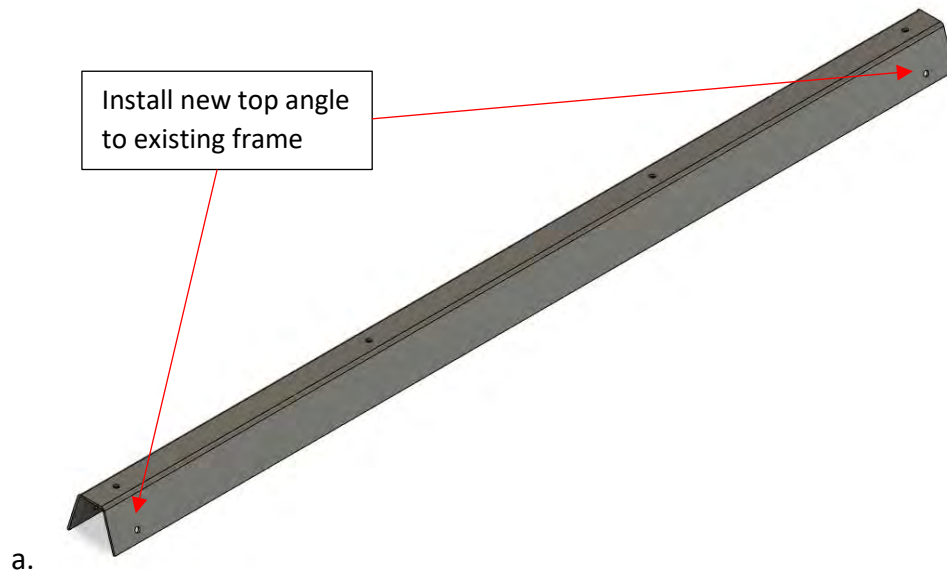

5. Install new frame divider rail, PN ARR-45X-0006 using (4) #6x2" SS sheet metal screws installed from under side:

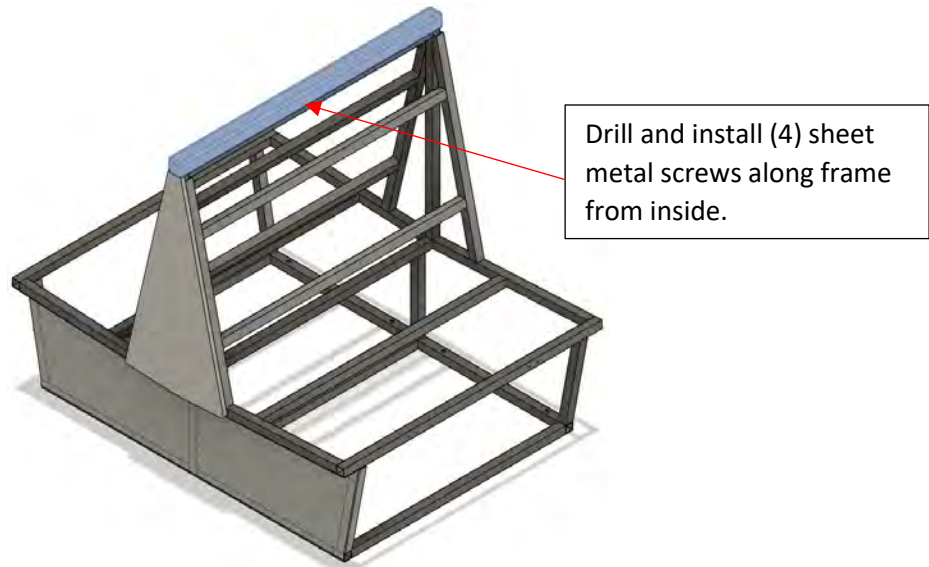

- a.
6. Install new side trim boards (ARRC provided), using #6 SS sheet metal screws, fastened from inside of seat frames:

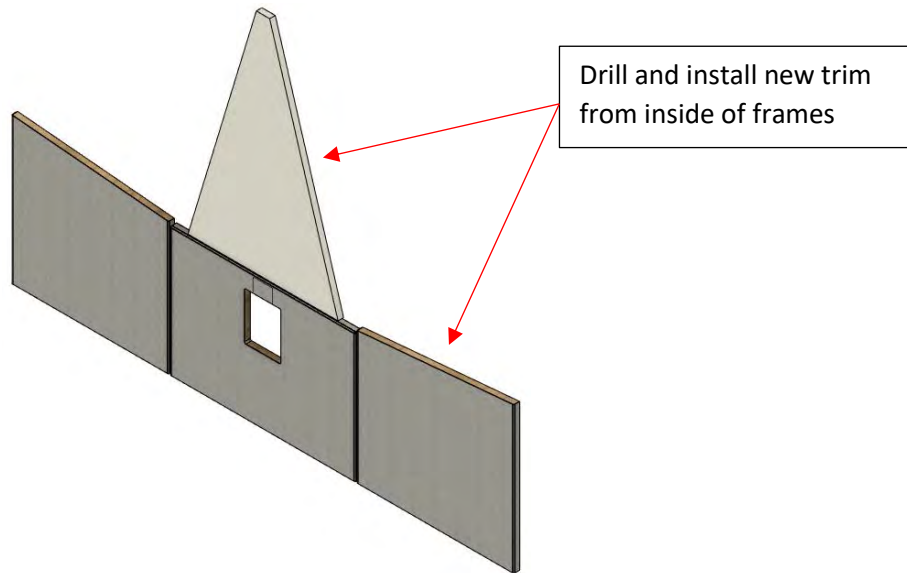

a.