



ALASKA RAILROAD CORPORATION
327 W. Ship Creek Ave.
Anchorage, AK 99501

February 08, 2019

Request for Quote 19-11-207066

The Alaska Railroad Corporation (ARRC) is soliciting bid from interested concerns for the following:

PASSENGER CAR REUPHOLSTERY PROJECT

Sealed or e-mailed quotes will be received at: Alaska Railroad Corporation
327 West ship Creek Ave.
Anchorage, AK 99501
Goemerg@akrr.com

Until 3:00 p.m., local time February 15, 2019. The envelope and or fax cover sheet used in submitting your offer shall be plainly marked with the following information;
Request for Quote #19-11-207066 Passenger Car Reupholstery

IMPORTANT: ARRC may award a contract resulting from this solicitation to the responsive bidder whose bid conforming to this solicitation will be the most advantageous to the ARRC. ARRC may reject any or all offers if such action is in the best interest of ARRC, and waive informalities and minor irregularities in offers received. Any resulting contract from this solicitation shall incorporate the Standard Instructions, and General Terms and Conditions incorporated in this solicitation.

PRE-BID/Site Visit Conference: A Pre-Quote Conference and Site Visit is scheduled for **February 13, 2019 at 10:00 AM** at the Alaska Railroad General Office Building (GOB) 327 W. Ship Creek Ave. Anchorage, AK 99501. All Contractors will sign-in at the pre-bid conference and once the conference is completed will proceed to the Car Shop. Please dress appropriately for weather and safety; hardhats, safety glasses and steel toe boots.

It is not mandatory that offerors attend the pre-offer conference. However, it is advised that all interested offerors attend. No other site inspection will be scheduled. In order to discourage unnecessary disruption of ARRC working employees, private inspections will not be granted.

A bidder's failure to visit the work site will in no way relieve the bidder of the responsibility of performing the work in strict compliance with the true intent and meaning of the terms, conditions and specifications of this RFQ.

This solicitation is not to be construed as a commitment of any kind nor does it commit the ARRC to pay for any costs incurred in the submission of an offer or for any other incurred cost prior to the execution of a formal contract.

Important: Work associated with this bid may be funded in part by funds from the Federal Transit Administration (“FTA”), an operating administration of the United States Department of Transportation; the Federal Railroad Administration (FRA); and the Alaska Railroad Corporation (ARRC). This solicitation package contains some provisions that are designated as applicable to FTA, FRA, and ARRC funded projects, mixed funding. See appendix H

ARRC Disadvantaged Business Enterprise (DBE) Program

ARRC is an equal opportunity corporation that encourages the participation of DBEs as prime contractors and subcontractors on its contracts funded in whole or in part by the Federal Transit or Federal Highway Administrations. The ARRC has a race neutral DBE Program and does not set DBE goals on individual solicitations. Nonetheless, the ARRC aspires to achieve an overall DBE participation of 3.0% in federal fiscal years 2019-2021 on contracts funded by agencies within the U.S. Department of Transportation. If this contract is funded in whole or in part by funds from the FTA or the FHWA, it is imperative that you consult the Federal Terms and Conditions portion of this solicitation.



The Alaska Railroad is a member of Green Star (<http://www.greenstarinc.org/>). ARRC earned an initial Green Star Award in 1994 and a Green Star Air Quality Award in 2007. The Alaska Railroad considers Green Star membership to be a positive business attribute, and regards a Green Star award as a tangible sign of an organization's commitment to environmental stewardship and continual improvement within its operations.

Please direct all responses and/or questions concerning this invitation to bid to Greg Goemer, Alaska Railroad Corporation, Supply Management, 327 W. Ship Creek Avenue, Anchorage, AK 99501, telephone number 907-265-2593, email address Goemerg@akrr.com

Sincerely,

Greg Goemer
Sr. Contract Administrator
Alaska Railroad Corporation

INDEX

APPENDIX A	SCOPE OF WORK
APPENDIX B	DRAWINGS & DIAGRAMS
APPENDIX C	COST SCHEDULE
APPENDIX D	BIDDERS QUESTIONNAIRE
APPENDIX E	FEDERAL TERMS AND CONDITIONS

REQUIRED DOCUMENTS

REQUIRED FOR BID. Bids will not be considered if the following documents are not completely filled out and submitted at the time of bidding:

1. Cost Schedule
2. Bidder's Questionnaire - [Form 395-0136]

REQUIRED FOR AWARD. In order to be awarded the contract, the successful bidder must completely fill out and submit the following documents within the time specified in the intent to award letter:

1. Certificate of Insurance - [from Insurance Carrier]
2. Alaska Contractors and Business Licenses
3. Service Contract - [Form 395-0130] and Notice to Proceed (ARRC Generated)

SPECIFICATIONS

SCOPE OF WORK

ARR 751

1. Renewal of interior upholstery. Car number is ARR 751 currently located at the Alaska Railroad Car Shop, in Anchorage.

All required compliant upholstery fabric and seat back foam will be provided by ARRC.

The scope includes portions of passenger seat units in car 751.

ARR 751: re-upholster 112 Seats with the following break down

- 104 seat back covers with new back foam
- 104 seat bottom covers reusing existing bottom foam
- 2 Jump seats to with contractor provided new foam
- 6 bench seats to with contractor provided new foam
- 10 new spare seat covers for back and bottom foam

Contractor shall perform and provide the following:

1. Provide ARRC with required quantities of fabric required for work to be performed.
2. Schedule time and date of cushion removal/replacement with Owner's representative. Contractor will be required to provide their own blue flag protection. ARRC will provide blue flag training.
3. Upholster new seat back cushions in ARR 751 using ARRC supplied fabric and seat back foam. The seat back covers must be tight fitting over and follow the contours of the seat back foam.
4. Upholster exist seat bottom cushions using ARRC supplied fabric, with a tight fitting process that minimizes gaps between cushions.
5. In addition, upholstery of jump seats and bench seats will require installation of Nomex FRQH fabric, over contractor provided foam. Must be high resiliency foam with a firmness rating of 55 IFD or approved equivalent.
6. Replace existing seat bottom webbing with 16 gauge galvanized steel seat pans. Seat pans must be deburred and fastened using steel rivets.
7. All sewing is to be made using contractor supplied 100% 65lbs NOMEX thread.
8. Perform basic cleaning of re-covered seat bottoms before reassembly.
9. Use only quality materials e.g. proper snaps, threads, glue, etc..
10. Reinstall refinished seat units to their original locations. Original fasteners may be reused when in good condition, otherwise contractor to furnish new in-kind fasteners as needed.
11. Item 2 is to provide 10 spare seat covers for back and bottom foam to allow Alaska Railroad to change out damaged seat covers during the summer passenger season.

Specifications of ARRC provided materials

Seat Back Upholstery:	Lantal 100% CS Trevira 12.27 oz/y2;
All other seats and locations:	Ultraleather Promessa color Buckwheat
Seat Cushion fire block:	Nomex 6.4 oz quilted FRQH fabric

ARR 651-656

2. Renewal of interior upholstery. Car numbers are ARR 651-656 currently located at the Alaska Railroad Car Shop, in Anchorage

All required compliant upholstery fabric and seat bottom foam will be provided by ARRC.

The scope includes portions of passenger seat units in cars ARR 651-656.

- ARR 651: Remove seat covers, wash and reinstall.
- ARR 652: Remove seat covers, wash and reinstall.
- ARR 653: Remove seat covers, wash and reinstall with new seat bottom cushions.
- ARR 654: Remove seat covers, wash and reinstall with new seat bottom cushions.
- ARR 655: Upholster new seat bottom covers, wash upper seat back covers and install with new seat bottom cushions.
- ARR 656: Upholster new seat bottom covers, wash upper seat back covers and install with new seat bottom cushions.

Contractor shall perform and provide the following:

1. Provide ARRC with required quantities of fabric required for work to be performed. There are 72 seats per 650 coach.
2. Schedule time and date of cushion removal/replacement with Owner's representative. Contractor will be required to provide their own blue flag protection. ARRC will provide blue flag training.
3. Upholster seat bottom cushions in 655 & 656 using ARRC supplied fabric.
4. All sewing is to be made using contractor supplied 100% 65lbs NOMEX thread.
5. Perform basic cleaning of re-covered seat foam before reassembly.
6. Use only quality materials e.g. proper zippers, threads, hook and loop, etc..
7. Reinstall refinished seat units to their original locations. Original fasteners may be reused when in good condition, otherwise contractor to furnish new in-kind fasteners as needed.
8. ARR 651 & 652 seat backs are slightly taller than in the ARR 653-656, and therefore the seat back are not interchangeable.

Specifications of ARRC provided materials

Seat Back Upholstery:	Lantal, Inc., Tapestry Pattern #OM-03-348 H;
All other seats and locations:	Ultraleather Promessa Merlot

Safety

Hard hats, safety glasses, hearing protection, and work boots are required in Alaska Railroad shops. Work inside passenger cars does not require hard hats be worn. Contractor will be required to coordinate daily, prior to beginning work, with Alaska Railroad car shop supervisor for blue flag protection (protection from moving railcars).

Expectations

1. Successful Contractor is responsible for the labor, transportation, storage and ancillary items.
2. Contractor will coordinate with other trades working in area.
3. Image is very important in regards to our passenger cars. The ARRC expects a professional upholstery job.
4. Contractor shall be responsible for pickup of materials from multiple locations Anchorage Ship Creek area and installed at Anchorage car shop.
5. All work to be completed by April 1st, 2019.

Work Schedule

Access to the shops outside of Monday thru Friday, 7 AM to 4 PM will require contractor complete an application for ARRC magnetic key and prior coordination for track lockout. If the key is lost, the contractor will be required to pay for the key.

All Passenger coaches will be available throughout spring 2019. There is the potential for heating the coaches in the yard outside and moving the coaches inside ARRC car shop, dependent on ARRC schedule.

DRAWINGS & DIAGRAMS

1. ARR 751 (DMU) Seat Upholstery Pattern
2. ARR 751 (DMU) Seat Bottom Foam – Manufacture’s Drawing
3. ARR 751 (DMU) Seat Back Foam – Manufacture’s Drawing
4. ARR 650’s Seat Specification Drawing
5. ARR 651 & 652 Seat Bottom Cushion Drawing
6. ARR 653-656 Seat Bottom Cushion Drawing
7. Side view of existing 650’s seat
8. Front view of existing 650’s seat with upholstery pattern detail

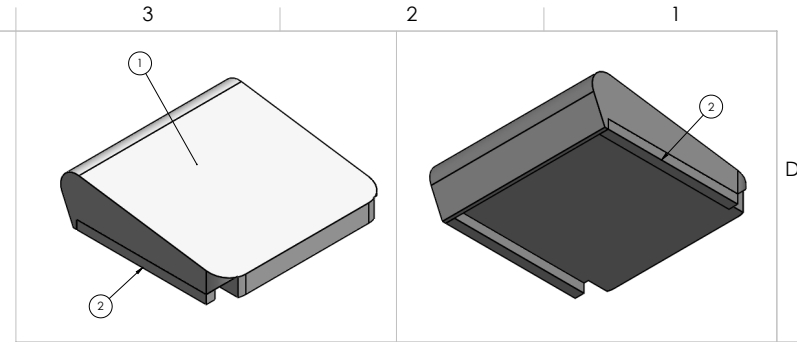
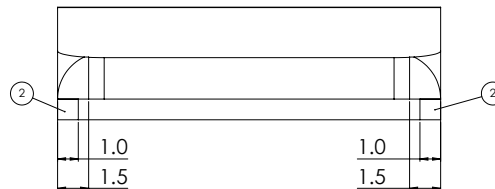
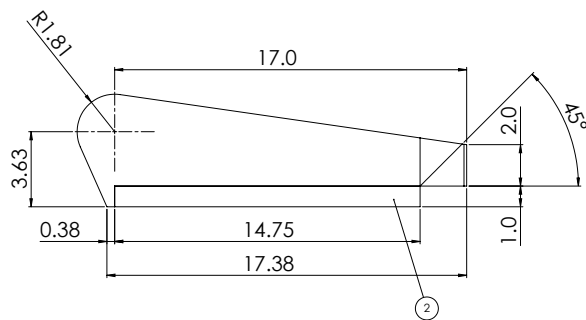
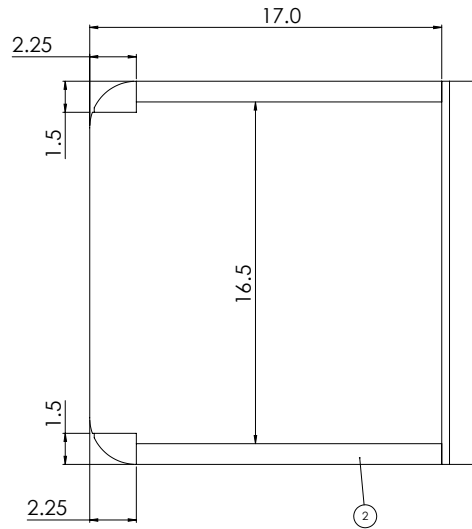
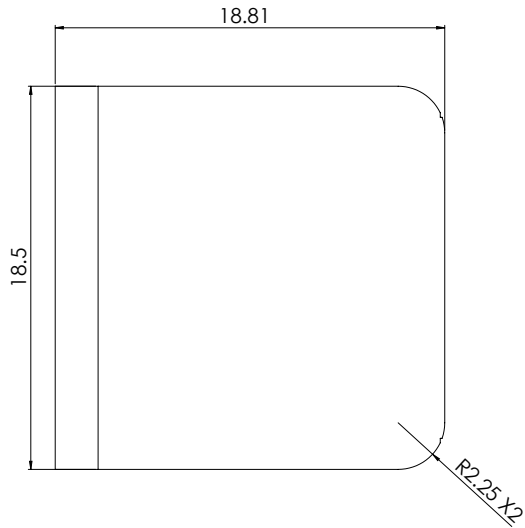

ITEM NO.	QTY.	PARTNUMBER	DESCRIPTION
1	1	N/A	MAIN CUSHION
2	2	N/A	SIDE STRIPS

CUSTOMER APPROVAL:

APPROVED BY:

DATE:

CUSTOMER P/N:

ADDITIONAL COMMENTS:

NO OBVIOUS DIFFERENCES BETWEEN ISLE AND WINDOW SEAT. PARTS SHOULD BE UNIVERSAL.

TOLERANCES:

LENGTH & WIDTH:	TOLERANCE
0" TO 12"	±1/8"
OVER 12" TO 24"	±1/4"
OVER 24" TO 48"	±3/8"
OVER 48"	±1/2"

THICKNESS:	TOLERANCE
0" TO 3"	+1/8", -1/16"
OVER 3" TO 5"	+3/16", -1/16"
OVER 5"	+3/16", -1/8"



THE INFORMATION CONTAINED IN THIS DRAWING IS THE SOLE PROPERTY OF ROGERS CORPORATION. ANY REPRODUCTION IN PART OR AS A WHOLE WITHOUT THE WRITTEN PERMISSION OF ROGERS CORPORATION IS PROHIBITED.

NOTES:
1. DO NOT SCALE DRAWING.
2. DIMENSIONS ARE IN INCHES UNLESS OTHERWISE NOTED.

PART NUMBER: ALASKA RAIL 42486	
REVISION: A	DATE: 4/1/16
MATERIAL: MF1-55	DRAWN BY: P. GARCES
SHEET SCALE: 1:2	SHEET: SHEET 1 OF 4

Vinyl: Ultraleather Promessa
color Buckwheat

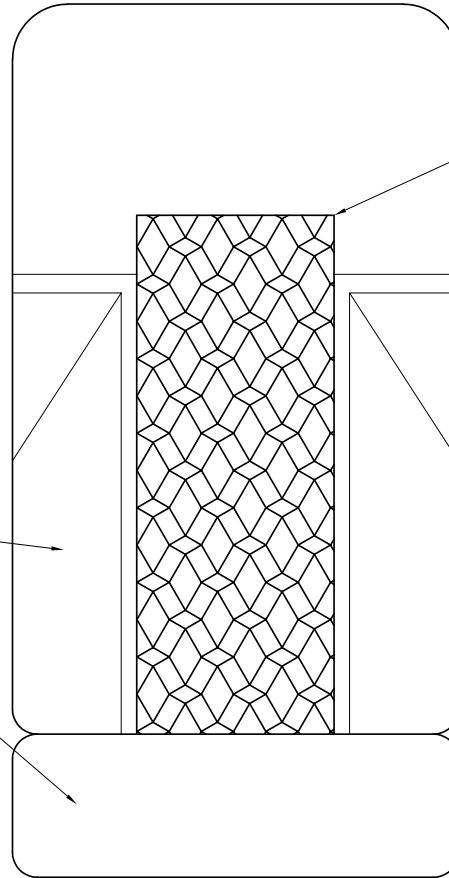

Fabric: Lantal 100% CS
Trevira 12.27 oz/y2

 ALASKA RAILROAD CORPORATION ENGINEERING SERVICES P.O. BOX 107500, ANCHORAGE, ALASKA 99510-7500		
PROJECT : MOTIVE POWER AND EQUIPMENT PASSENGER EQUIPMENT		
TITLE: ARR 751 (DMU) SEAT UPHOLSTERY PATTERN		
DESIGNED BY: —	SCALE : NTS	REF. NO.:
DRAWN BY: JAK		ACAD FILE:
CHECKED BY: CDR	DATE : 01/03/19	DWG NO. 1 OF 1
APPROVED BY: DG		

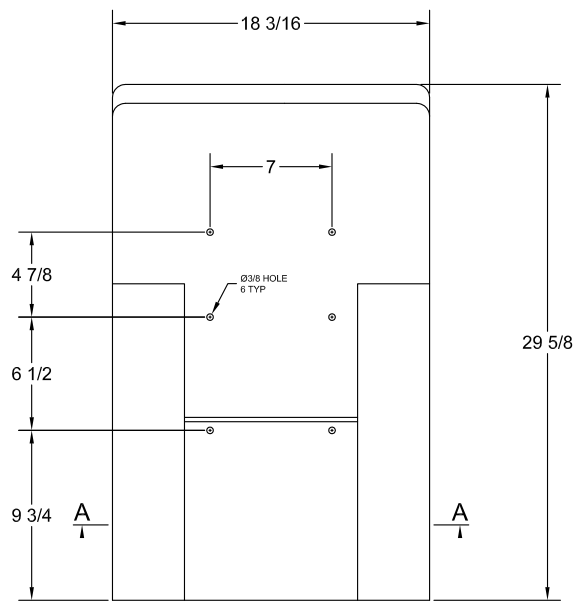

FRONT VIEW

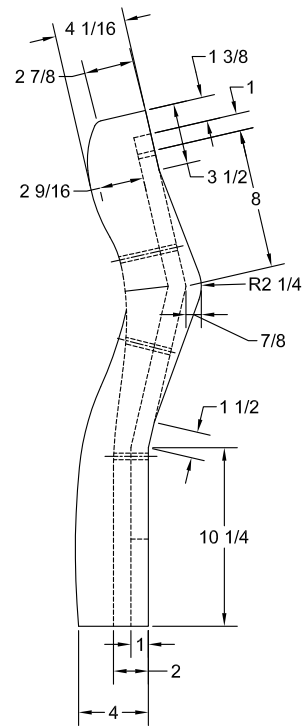

SIDE VIEW

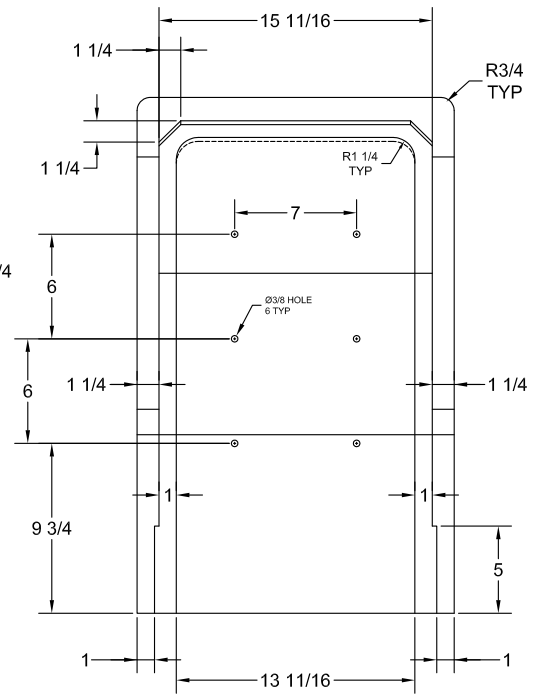

REAR VIEW

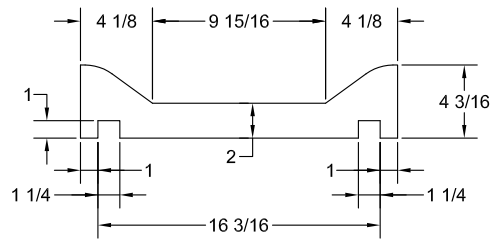

SECTION A-A

THE INFORMATION ON THIS DOCUMENT IS PROPRIETARY. RECEIPT BY ITS RECIPIENT AGREES TO KEEP THIS DATA CONFIDENTIAL IN ALL RESPECTS. INFORMATION ON THIS DOCUMENT SHALL NOT BE COPIED NOR REPRODUCED IN ANY MANNER, NOR DISCLOSED ORALLY OR IN WRITING TO ANY THIRD PARTY, WITHOUT OUR EXPRESS WRITTEN AUTHORIZATION.

REV	DESCRIPTION	INIT	DATE
A	PRODUCTION RELEASE	DRZ	30AUG06
B	REV NOTE # 2 TRAY TABLE SPEC	NCD	18SEP06
C	ADD'D SIDE VIEW & WEDDELL REV'S	SPF	18JAN07

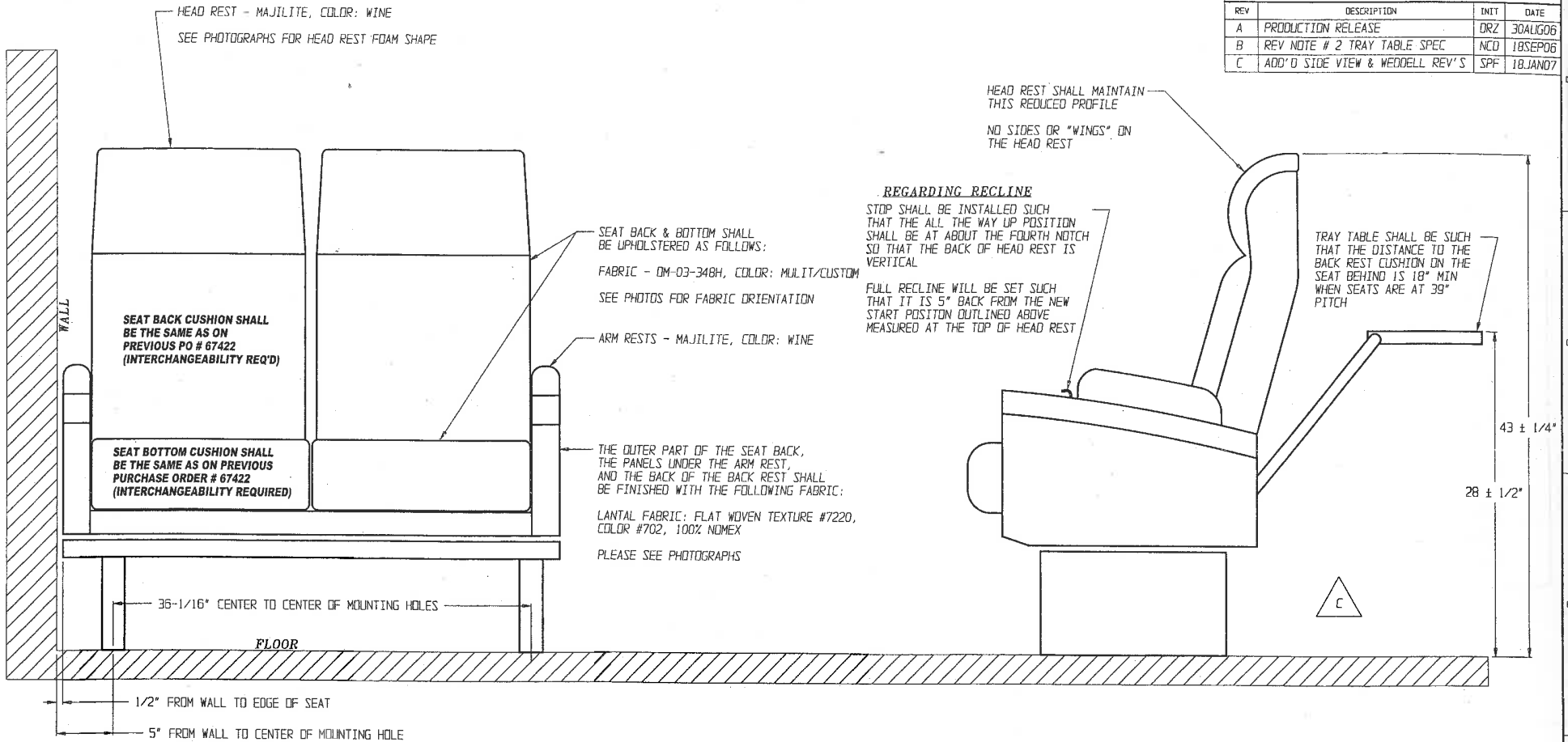

NOTES:

- SEATS SHALL HAVE THE FOLLOWING FEATURES:
RECLINE FOR EACH PASSENGER
ROTATE 180° - WITH FOOT PEDAL BACK
- TRAY TABLE COLOR - S52 SERIES SMC LIGHT GREY WITH RECESS FOR GLASS
- SEAT FOAM SHALL BE CHESTNUT RIDGE FOAM - SOFTEST AVAILABLE

APPROVED

DIMENSION TOLERANCE = ± 1/16"
ANGULAR TOLERANCE = ± 1°
DRILLED HOLE TOLERANCE = ± φ 1/64"
UNLESS OTHERWISE SPECIFIED

COLORADO RAILCAR MFG LLC FT LUPTON, COLORADO 303/857-1066	
PROJECT: ALASKA RR 2006	
RAILCAR(S): TYPE 1	SCALE (D): 1/4"=1"
DRAFTED BY: SPF	CHECKED BY: <i>SPF</i> 2/1/07
DOME SEAT SPECIFICATION DRAWING	APPROVED BY: <i>SPF</i> 2/1/07
	MODEL: _____

CRM # 7820854F

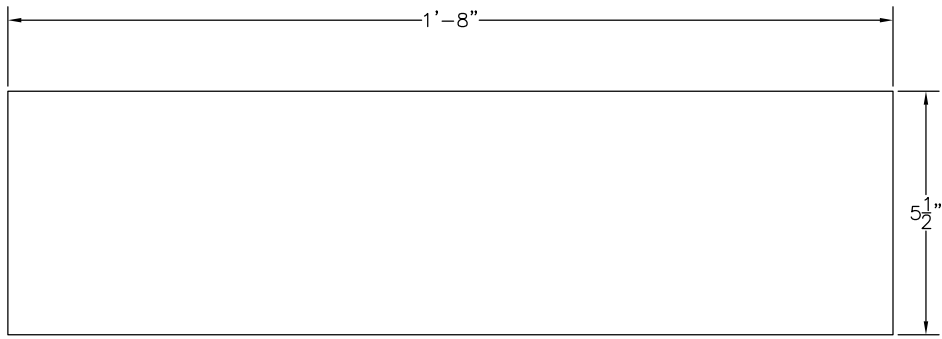

A
1 **651-652 SEAT BOTTOM CUSHION SECTION**
NO SCALE

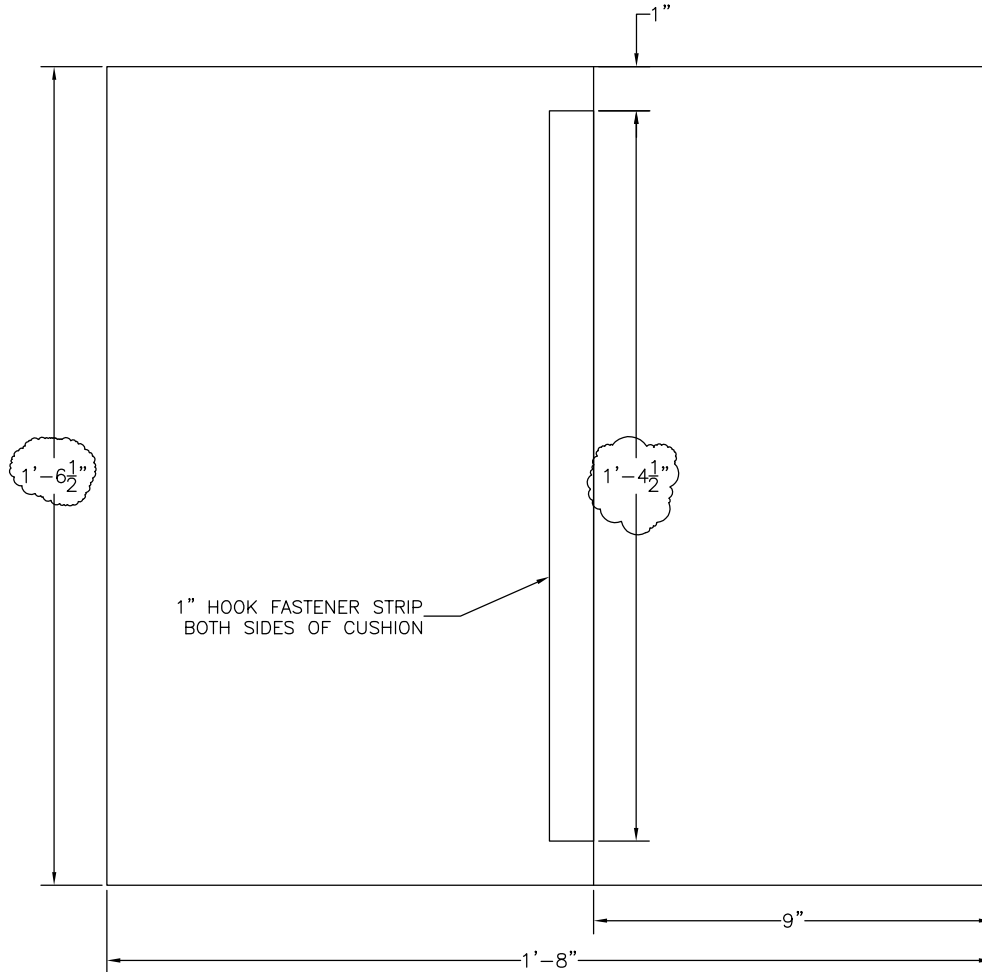

B
1 **651-652 SEAT BOTTOM CUSHION PLAN**
NO SCALE

SILICONE FOAM, MF1-50, MEETING
REQUIREMENTS OF 49 CFR PART 238

 ALASKA RAILROAD CORPORATION ENGINEERING SERVICES P.O. BOX 107500, ANCHORAGE, ALASKA 99510-7500		
PROJECT : MOTIVE POWER & EQUIPMENT PASSENGER COACHES		
TITLE: ARR 651-652 SEAT BOTTOM CUSHION		
DESIGNED BY: <u>CDR</u>	SCALE : NO SCALE	A/E NO.:
DRAWN BY: <u>CDR</u>		ACAD FILE:
CHECKED BY: <u>CDR</u>	DATE : OCTOBER 2016	DWG NO.
APPROVED BY: <u>CDR</u>		1 OF 1

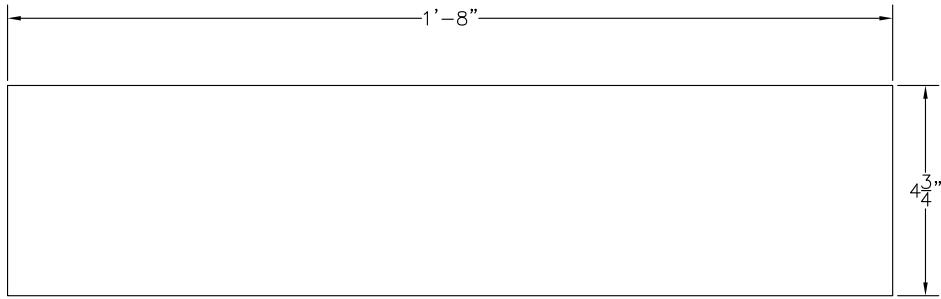

A
1 **653-656 SEAT BOTTOM CUSHION SECTION**
NO SCALE

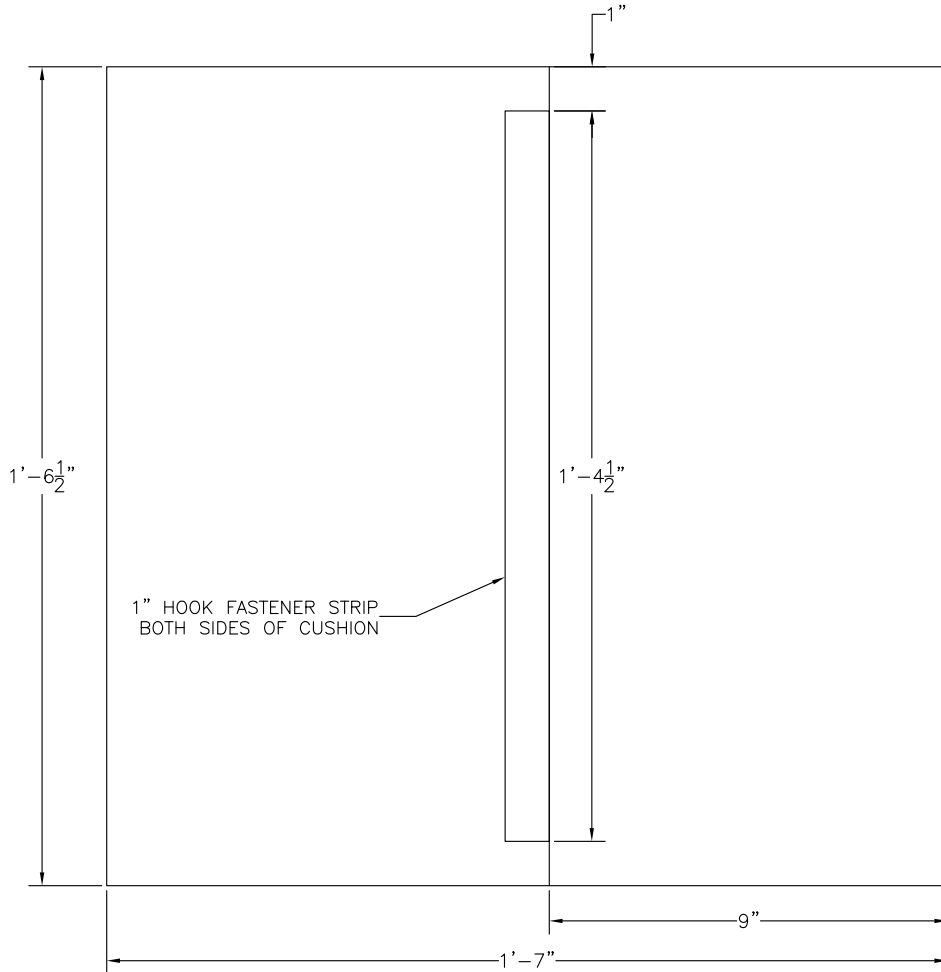

B
1 **653-656 SEAT BOTTOM CUSHION PLAN**
NO SCALE

SILICONE FOAM, MF1-55, MEETING
REQUIREMENTS OF 49 CFR PART 238

 ALASKA RAILROAD CORPORATION ENGINEERING SERVICES P.O. BOX 107500, ANCHORAGE, ALASKA 99510-7500		
PROJECT : MOTIVE POWER & EQUIPMENT PASSENGER COACHES		
TITLE: ARR 653-656 SEAT BOTTOM CUSHION		
DESIGNED BY: CDR	SCALE : NO SCALE	AFE NO.:
DRAWN BY: CDR		ACAD FILE:
CHECKED BY: CDR	DATE : DECEMBER 2017	DWG NO.
APPROVED BY: CDR		1 OF 1



Seat Bottoms to be Upholstered with Tappis Ultraleather Promessa Merlot



APPENDIX C
COST SCHEDULE

A bidder's failure to provide the information requested in this section will be cause for rejection of the bid on the basis of non-responsiveness. Bidder hereby offers to perform the work in strict compliance with the Bid documents for the following lump sum price:

DESCRIPTION	LUMP SUM TOTAL
Provide Upholstery Services in accordance with the Terms, Conditions and Specifications.	
Item 1: ARR 751 Seat Covers with installation	\$ _____
Item 2: Ten ARR 751 Seat Cover Spares	\$ _____
Item 3: ARR 651 & 652 Seat Cover Wash	\$ _____
Item 4: ARR 653 & 654 Seat Cover Wash with Foam	\$ _____
Item 5: ARR 655 & 656 Upholster Seat Bottom Covers with Foam	\$ _____

AWARD CRITERIA: An award will be made to the low, responsive, responsible bidder that meets the requirements as set forth in the specifications and compliance thereof. The Alaska Railroad Corporation reserves the right to determine that all offered materials will serve the application intended and be in the best interest of the Alaska Railroad.

The bid award is contingent on the availability of Federal Transit Administration and Alaska Railroad Corporation funds.

The Undersigned has read the foregoing RFQ and hereby agrees to the terms and condition stated therein by affixing his/her signature below.

NON-COLLUSION AFFIDAVIT: The Undersigned declares, under penalty of perjury under the laws of the United States, that neither he/she nor the firm, association, or corporation of which he/she is a member, has, either directly or indirectly, entered into any agreement, participated in any collusion, or otherwise taken any action in restraint of free competitive bidding in connection with this Bid.

BIDDERS NAME AND ADDRESS

COMPANY NAME
BIDDER

COMPANY ADDRESS

CONTACT PHONE NUMBER

SIGNATURE BY AND FOR THE

PRINTED NAME OF ABOVE BIDDER

DATE OF BID

CONTACT E-MAIL

QUESTIONNAIRE

Note: Failure to provide the information requested in this questionnaire may be cause for rejection of your bid or offer on the grounds of non-responsiveness and/or non-responsibility.

Project: _____

Name of Your Business: _____

Street Address: _____

Mailing Address if Different: _____

City: _____ State: _____ Mailing Zip: _____

Telephone: _____ Fax: _____ Email: _____

Date Firm Established: _____

How many years has the business been under the above name? _____

Previous business name(s)if any: _____

Federal Tax ID Number: _____

Business License Number: _____

Contractor License Number (For Construction): _____

Bid Acceptance Period _____ Days. (Bids providing less than thirty - 30 calendar days for acceptance may be considered non-responsive and may be rejected.)

Discount for prompt pay _____ % _____ days.

The bidder shall list any variations from or exceptions to the Terms, Conditions or Specifications of the Solicitation:

List the three most recent contracts performed by your company where the commodity or service requested in this solicitation was the primary commodity or service supplied. Include the client's name, contract amount, contract date, person to contact regarding performance, their telephone, facsimile number and e-mail.

Clients name, Contact person, Contact info. Description of Work and Contract Amount
 (Provide: telephone, fax, and email)

<u>List any other business related experience:</u>	

Are you acting as a broker or the primary supplier in this transaction?

- Broker
- Primary Supplier

Business Information (Please check all that apply):

- My business is Individual
- My business is a Partnership
- My business is a Non-Profit
- My business is a Joint-Venture
- My business is a Corporation incorporated under the laws of the State of _____
- My business is full-time
- My business is part-time
- My business **is not** a certified Disadvantaged Business (DBE)
- My business **is** a certified DBE
- My DBE was certified by State DOTPF
- My DBE was certified by the Municipality of Anchorage
- My business is an 8(a)/WBE/MBE and is certified by SBA
- My business was certified by _____
- My DBE Certification # is _____

Firms Annual Gross Receipts:

- <\$500,000
- \$500,000 - \$999,999
- \$1,000,000 - \$4,999,999
- \$5,000,000 - \$9,999,999
- \$10,000,000 - \$16,999,999
- >\$17,000,000

Completed by: _____ **Title:** _____

Signature: _____ **Date:** _____

**REQUIRED CONTRACT PROVISIONS
FOR FEDERAL-AID CONTRACTS
(Less than \$100,000)
[Revised 8/19/13]**

The following contract provisions shall apply, where applicable, to all work performed on the contract by the contractor's own organization and by subcontractors. As provided in this Section, the contractor shall insert in each subcontract all of the stipulations contained in these Required Contract Provisions and further require their inclusion in any lower tier subcontracts or purchase orders that may in turn be made. Incorporation by reference shall not be allowed. The prime contractor shall be responsible for compliance by any subcontractor or lower tier subcontractor with all applicable Required Contract Provisions.

1. CARGO PREFERENCE REQUIREMENTS - 46 USC §1241, 46 CFR Part 381
[Applicable to all Federal-aid contracts involving equipment, materials or commodities which may be transported by ocean vessel]

Cargo Preference Use of United States-Flag Vessels - The contractor agrees: **a. to use** privately owned United States-Flag commercial vessels to ship at least 50 percent of the gross tonnage (computed separately for dry bulk carriers, dry cargo liners, and tankers) involved, whenever shipping any equipment, material, or commodities pursuant to the underlying contract to the extent such vessels are available at fair and reasonable rates for United States-Flag commercial vessels; **b. to furnish** within twenty (20) working days following the date of loading for shipments originating within the United States or within thirty (30) working days following the date of loading for shipments originating outside the United States, a legible copy of a rated, "on-board" commercial ocean bill-of-lading in English for each shipment of cargo described in the preceding subsection to the Division of National Cargo, Office of Market Development, Maritime Administration, Washington, DC 20590 and to ARRC (through the contractor in the case of a subcontractor's bill-of-lading.) **c. to include these** requirements in all subcontracts issued pursuant to this contract when the subcontract may involve the transport of equipment, material, or commodities by ocean vessel.

2. DEBARMENT, SUSPENSION, INELIGIBILITY & VOLUNTARY EXCLUSION - 49 CFR Part 29; Executive Order 12549 [Applicable to all Federal-aid contracts which exceed \$25,000]

Instructions for Certification - Lower Tier Covered Transactions:

1. By signing and submitting this bid or proposal, the prospective lower tier participant is providing the signed certification set out below.
2. The certification in this clause is a material representation of fact upon which reliance was placed when this transaction was entered into. If it is later determined that the prospective lower tier participant knowingly rendered an erroneous certification, in addition to other remedies available to the Federal Government, ARRC may pursue available remedies, including suspension and/or debarment.

3. The prospective lower tier participant shall provide immediate written notice to ARRC if at any time the prospective lower tier participant learns that its certification was erroneous when submitted or has become erroneous by reason of changed circumstances.

4. The terms "covered transaction," "debarred," "suspended," "ineligible," "lower tier covered transaction," "participant," "persons," "lower tier covered transaction," "principal," "proposal," and voluntarily excluded," as used in this clause, have the meanings set out in the Definitions and Coverage sections of rules implementing Executive Order 12549 [49 CFR Part 29]. You may contact ARRC for assistance in obtaining a copy of those regulations.

5. The prospective lower tier participant agrees by submitting this proposal that, should the proposed covered transaction be entered into, it shall not knowingly enter into any lower tier covered transaction with a person who is debarred, suspended, declared ineligible, or voluntarily excluded from participation in this covered transaction, unless authorized in writing by ARRC.

6. The prospective lower tier participant further agrees by submitting this proposal that it will include the clause titled "Certification Regarding Debarment, Suspension, Ineligibility and Voluntary Exclusion-Lower Tier Covered Transaction", without modification, in all lower tier covered transactions and in all solicitations for lower tier covered transactions.

7. A participant in a covered transaction may rely upon a certification of a prospective participant in a lower tier covered transaction that it is not debarred, suspended, ineligible, or voluntarily excluded from the covered transaction, unless it knows that the certification is erroneous. A participant may decide the method and frequency by which it determines the eligibility of its principals. Each participant may, but is not required to, check the Non-procurement List issued by U.S. General Service Administration.

8. Nothing contained in the foregoing shall be construed to require establishment of system of records in order to render in good faith the certification required by this clause. The knowledge and information of a participant is not required to exceed that which is normally possessed by a prudent person in the ordinary course of business dealings.

9. Except for transactions authorized under Paragraph 5 of these instructions, if a participant in a covered transaction knowingly enters into a lower tier covered transaction with a person who is suspended, debarred, ineligible, or voluntarily excluded from participation in this transaction, in addition to all remedies available to the Federal Government, ARRC may pursue available remedies including suspension and/or debarment.

Certification Regarding Debarment, Suspension, Ineligibility and Voluntary Exclusion Lower Tier Covered Transaction

(1) The prospective lower tier participant certifies, by submission of this bid or proposal, that neither it nor its "principals" [as defined at 49 CFR §29.105(p)] is presently debarred, suspended, proposed for debarment, declared ineligible, or voluntarily excluded from participation in this transaction by any Federal department or agency.

(2) When the prospective lower tier participant is unable to certify to the statements in this certification, such prospective participant shall attach an explanation to this proposal.

3. DAVIS-BACON AND COPELAND ANTI-KICKBACK ACTS - 40 USC 3141 et seq.; 18 USC 874; 29 CFR Part 5; 49 CFR 18.36(i)(5) [Applicable to all Federal-aid construction contracts which exceed \$2,000]

(1) Minimum wages - (i) All laborers and mechanics employed or working upon the site of the work (or under the United States Housing Act of 1937 or under the Housing Act of 1949 in the construction or development of the project), will be paid unconditionally and not less often than once a week, and without subsequent deduction or rebate on any account (except such payroll deductions as are permitted by regulations issued by the Secretary of Labor under the Copeland Act (29 CFR part 3)), the full amount of wages and bona fide fringe benefits (or cash equivalents thereof) due at time of payment computed at rates not less than those contained in the wage determination of the Secretary of Labor which is attached hereto and made a part hereof, regardless of any contractual relationship which may be alleged to exist between the contractor and such laborers and mechanics.

Contributions made or costs reasonably anticipated for bona fide fringe benefits under section 1(b)(2) of the Davis-Bacon Act on behalf of laborers or mechanics are considered wages paid to such laborers or mechanics, subject to the provisions of paragraph (1)(iv) of this section; also, regular contributions made or costs incurred for more than a weekly period (but not less often than quarterly) under plans, funds, or programs which cover the particular weekly period, are deemed to be constructively made or incurred during such weekly period. Such laborers and mechanics shall be paid the appropriate wage rate and fringe benefits on the wage determination for the classification of work actually performed, without regard to skill, except as provided in 29 CFR Part 5.5(a)(4). Laborers or mechanics performing work in more than one classification may be compensated at the rate specified for each classification for the time actually worked therein: Provided, that the employer's payroll records accurately set forth the time spent in each classification in which work is performed. The wage determination (including any additional classifications and wage rates conformed under paragraph (1)(ii) of this section) and the Davis-Bacon poster (WH-1321) shall be posted at all times by the contractor and its subcontractors at the site of the work in a prominent and accessible place where it can be easily seen by the workers.

(ii)(A) The contracting officer shall require that any class of laborers or mechanics, including helpers, which is not listed in the wage determination and which is to be employed under the contract shall be classified in conformance with the wage determination. The contracting officer shall approve an additional classification and wage rate and fringe benefits therefore only when the following criteria have been met:

(1) Except with respect to helpers as defined as 29 CFR 5.2(n)(4), the work to be performed by the classification requested is not performed by a classification in the wage determination; and

(2) The classification is utilized in the area by the construction industry; and

(3) The proposed wage rate, including any bona fide fringe benefits, bears a reasonable relationship to the wage rates contained in the wage determination; and

(4) With respect to helpers as defined in 29 CFR 5.2(n)(4), such a classification prevails in the area in which the work is performed.

(B) If the contractor and the laborers and mechanics to be employed in the classification (if known), or their representatives, and the contracting officer agree on the classification and wage rate (including the amount designated for fringe benefits where appropriate), a report of the action taken shall be sent by the contracting officer to the Administrator of the Wage and Hour Division, Employment Standards Administration, U.S. Department of Labor, Washington, DC 20210. The Administrator, or an authorized representative, will approve, modify, or disapprove every additional classification action within 30 days of receipt and so advise the contracting officer or will notify the contracting officer within the 30-day period that additional time is necessary.

(C) In the event the contractor, the laborers or mechanics to be employed in the classification or their representatives, and the contracting officer do not agree on the proposed classification and wage rate (including the amount designated for fringe benefits, where appropriate), the contracting officer shall refer the questions, including the views of all interested parties and the recommendation of the contracting officer, to the Administrator for determination. The Administrator, or an authorized representative, will issue a determination within 30 days of receipt and so advise the contracting officer or will notify the contracting officer within the 30-day period that additional time is necessary.

(D) The wage rate (including fringe benefits where appropriate) determined pursuant to paragraphs (a)(1)(ii) (B) or

(C) of this section, shall be paid to all workers performing work in the classification under this contract from the first day on which work is performed in the classification.

(iii) Whenever the minimum wage rate prescribed in the contract for a class of laborers or mechanics includes a fringe benefit which is not expressed as an hourly

rate, the contractor shall either pay the benefit as stated in the wage determination or shall pay another bona fide fringe benefit or an hourly cash equivalent thereof.

(iv) If the contractor does not make payments to a trustee or other third person, the contractor may consider as part of the wages of any laborer or mechanic the amount of any costs reasonably anticipated in providing bona fide fringe benefits under a plan or program, Provided, That the Secretary of Labor has found, upon the written request of the contractor, that the applicable standards of the Davis-Bacon Act have been met. The Secretary of Labor may require the contractor to set aside in a separate account assets for the meeting of obligations under the plan or program.

(v)(A) The contracting officer shall require that any class of laborers or mechanics which is not listed in the wage determination and which is to be employed under the contract shall be classified in conformance with the wage determination. The contracting officer shall approve an additional classification and wage rate and fringe benefits therefore only when the following criteria have been met:

(1) The work to be performed by the classification requested is not performed by a classification in the wage determination; and

(2) The classification is utilized in the area by the construction industry; and

(3) The proposed wage rate, including any bona fide fringe benefits, bears a reasonable relationship to the wage rates contained in the wage determination.

(B) If the contractor and the laborers and mechanics to be employed in the classification (if known), or their representatives, and the contracting officer agree on the classification and wage rate (including the amount designated for fringe benefits where appropriate), a report of the action taken shall be sent by the contracting officer to the Administrator of the Wage and Hour Division, Employment Standards Administration, Washington, DC 20210. The Administrator, or an authorized representative, will approve, modify, or disapprove every additional classification action within 30 days of receipt and so advise the contracting officer or will notify the contracting officer within the 30-day period that additional time is necessary.

(C) In the event the contractor, the laborers or mechanics to be employed in the classification or their representatives, and the contracting officer do not agree on the proposed classification and wage rate (including the amount designated for fringe benefits, where appropriate), the contracting officer shall refer the questions, including the views of all interested parties and the recommendation of the contracting officer, to the Administrator for determination. The Administrator, or an authorized representative, will issue a determination with 30 days of receipt and so advise the contracting officer or will notify the contracting officer within the 30-day period that additional time is necessary.

(D) The wage rate (including fringe benefits where appropriate) determined pursuant to paragraphs (a)(1)(v) (B) or

(C) of this section, shall be paid to all workers performing work in the classification under this contract from the first day on which work is performed in the classification.

(2) Withholding - ARRC shall upon its own action or upon written request of an authorized representative of the Department of Labor withhold or cause to be withheld from the contractor under this contract or any other Federal contract with the same prime contractor, or any other federally-assisted contract subject to Davis-Bacon prevailing wage requirements, which is held by the same prime contractor, so much of the accrued payments or advances as may be considered necessary to pay laborers and mechanics, including apprentices, trainees, and helpers, employed by the contractor or any subcontractor the full amount of wages required by the contract. In the event of failure to pay any laborer or mechanic, including any apprentice, trainee, or helper, employed or working on the site of the work (or under the United States Housing Act of 1937 or under the Housing Act of 1949 in the construction or development of the project), all or part of the wages required by the contract, ARRC may, after written notice to the contractor, sponsor, applicant, or owner, take such action as may be necessary to cause the suspension of any further payment, advance, or guarantee of funds until such violations have ceased.

(3) Payrolls and basic records - (i) Payrolls and basic records relating thereto shall be maintained by the contractor during the course of the work and preserved for a period of three years thereafter for all laborers and mechanics working at the site of the work (or under the United States Housing Act of 1937, or under the Housing Act of 1949, in the construction or development of the project). Such records shall contain the name, address, and social security number of each such worker, his or her correct classification, hourly rates of wages paid (including rates of contributions or costs anticipated for bona fide fringe benefits or cash equivalents thereof of the types described in section 1(b)(2)(B) of the Davis-Bacon Act), daily and weekly number of hours worked, deductions made and actual wages paid. Whenever the Secretary of Labor has found under 29 CFR 5.5(a)(1)(iv) that the wages of any laborer or mechanic include the amount of any costs reasonably anticipated in providing benefits under a plan or program described in section 1(b)(2)(B) of the Davis-Bacon Act, the contractor shall maintain records which show that the commitment to provide such benefits is enforceable, that the plan or program is financially responsible, and that the plan or program has been communicated in writing to the laborers or mechanics affected, and records which show the costs anticipated or the actual cost incurred in providing such benefits. Contractors employing apprentices or trainees under approved programs shall maintain written evidence of the registration of apprenticeship programs and certification of trainee programs, the registration of the apprentices and trainees, and the ratios and wage rates prescribed in the applicable programs.

(ii)(A) The contractor shall submit weekly for each week in which any contract work is performed a copy of all payrolls to ARRC for transmission to the Federal grantor agency. The payrolls submitted shall set out accurately and completely all of the information required to be maintained under section 5.5(a)(3)(i) of Regulations, 29 CFR part 5. This information may be submitted in any form desired. Optional Form WH-347

is available for this purpose and may be purchased from the Superintendent of Documents (Federal Stock Number 029-005-00014-1), U.S. Government Printing Office, Washington, DC 20402. The prime contractor is responsible for the submission of copies of payrolls by all subcontractors.

(B) Each payroll submitted shall be accompanied by a "Statement of Compliance," signed by the contractor or subcontractor or his or her agent who pays or supervises the payment of the persons employed under the contract and shall certify the following:

(1) That the payroll for the payroll period contains the information required to be maintained under section 5.5(a)(3)(i) of Regulations, 29 CFR part 5 and that such information is correct and complete;

(2) That each laborer or mechanic (including each helper, apprentice, and trainee) employed on the contract during the payroll period has been paid the full weekly wages earned, without rebate, either directly or indirectly, and that no deductions have been made either directly or indirectly from the full wages earned, other than permissible deductions as set forth in Regulations, 29 CFR part 3;

(3) That each laborer or mechanic has been paid not less than the applicable wage rates and fringe benefits or cash equivalents for the classification of work performed, as specified in the applicable wage determination incorporated into the contract.

(C) The weekly submission of a properly executed certification set forth on the reverse side of Optional Form WH-347 shall satisfy the requirement for submission of the "Statement of Compliance" required by paragraph (a)(3)(ii)(B) of this section.

(D) The falsification of any of the above certifications may subject the contractor or subcontractor to civil or criminal prosecution under section 1001 of title 18 and section 231 of title 31 of the United States Code.

(iii) The contractor or subcontractor shall make the records required under paragraph (a)(3)(i) of this section available for inspection, copying, or transcription by authorized representatives of the Federal grantor agency or the Department of Labor, and shall permit such representatives to interview employees during working hours on the job. If the contractor or subcontractor fails to submit the required records or to make them available, the Federal agency may, after written notice to the contractor, sponsor, applicant, or owner, take such action as may be necessary to cause the suspension of any further payment, advance, or guarantee of funds. Furthermore, failure to submit the required records upon request or to make such records available may be grounds for debarment action pursuant to 29 CFR 5.12.

(4) Apprentices and trainees - (i) Apprentices - Apprentices will be permitted to work at less than the predetermined rate for the work they performed when they are employed pursuant to and individually registered in a bona fide apprenticeship program registered with the U.S. Department of Labor, Employment and Training Administration, Bureau of Apprenticeship and Training, or with a State Apprenticeship Agency

recognized by the Bureau, or if a person is employed in his or her first 90 days of probationary employment as an apprentice in such an apprenticeship program, who is not individually registered in the program, but who has been certified by the Bureau of Apprenticeship and Training or a State Apprenticeship Agency (where appropriate) to be eligible for probationary employment as an apprentice. The allowable ratio of apprentices to journeymen on the job site in any craft classification shall not be greater than the ratio permitted to the contractor as to the entire work force under the registered program. Any worker listed on a payroll at an apprentice wage rate, who is not registered or otherwise employed as stated above, shall be paid not less than the applicable wage rate on the wage determination for the classification of work actually performed. In addition, any apprentice performing work on the job site in excess of the ratio permitted under the registered program shall be paid not less than the applicable wage rate on the wage determination for the work actually performed. Where a contractor is performing construction on a project in a locality other than that in which its program is registered, the ratios and wage rates (expressed in percentages of the journeyman's hourly rate) specified in the contractor's or subcontractor's registered program shall be observed. Every apprentice must be paid at not less than the rate specified in the registered program for the apprentice's level of progress, expressed as a percentage of the journeymen hourly rate specified in the applicable wage determination. Apprentices shall be paid fringe benefits in accordance with the provisions of the apprenticeship program. If the apprenticeship program does not specify fringe benefits, apprentices must be paid the full amount of fringe benefits listed on the wage determination for the applicable classification. If the Administrator of the Wage and Hour Division of the U.S. Department of Labor determines that a different practice prevails for the applicable apprentice classification, fringes shall be paid in accordance with that determination. In the event the Bureau of Apprenticeship and Training, or a State Apprenticeship Agency recognized by the Bureau, withdraws approval of an apprenticeship program, the contractor will no longer be permitted to utilize apprentices at less than the applicable predetermined rate for the work performed until an acceptable program is approved.

(ii) Trainees - Except as provided in 29 CFR 5.16, trainees will not be permitted to work at less than the predetermined rate for the work performed unless they are employed pursuant to and individually registered in a program which has received prior approval, evidenced by formal certification by the U.S. Department of Labor, Employment and Training Administration. The ratio of trainees to journeymen on the job site shall not be greater than permitted under the plan approved by the Employment and Training Administration. Every trainee must be paid at not less than the rate specified in the approved program for the trainee's level of progress, expressed as a percentage of the journeyman hourly rate specified in the applicable wage determination. Trainees shall be paid fringe benefits in accordance with the provisions of the trainee program. If the trainee program does not mention fringe benefits, trainees shall be paid the full amount of fringe benefits listed on the wage determination unless the Administrator of the Wage and Hour Division determines that there is an apprenticeship program associated with the corresponding journeyman wage rate on the wage determination which provides for less than full fringe benefits for apprentices. Any employee listed on the payroll at a trainee rate who is not registered and participating in a training plan

approved by the Employment and Training Administration shall be paid not less than the applicable wage rate on the wage determination for the classification of work actually performed. In addition, any trainee performing work on the job site in excess of the ratio permitted under the registered program shall be paid not less than the applicable wage rate on the wage determination for the work actually performed. In the event the Employment and Training Administration withdraws approval of a training program, the contractor will no longer be permitted to utilize trainees at less than the applicable predetermined rate for the work performed until an acceptable program is approved.

(iii) Equal employment opportunity - The utilization of apprentices, trainees and journeymen under this part shall be in conformity with the equal employment opportunity requirements of Executive Order 11246, as amended, and 29 CFR part 30.

(5) Compliance with Copeland Act requirements - The contractor shall comply with the requirements of 29 CFR Part 3, which are incorporated by reference in this contract.

(6) Subcontracts - The contractor or subcontractor shall insert in any subcontracts the clauses contained in 29 CFR 5.5(a)(1) through (10) and such other clauses as the Federal Transit Administration may by appropriate instructions require, and also a clause requiring the subcontractors to include these clauses in any lower tier subcontracts. The prime contractor shall be responsible for the compliance by any subcontractor or lower tier subcontractor with all the contract clauses in 29 CFR 5.5.

(7) Contract termination: debarment - A breach of the contract clauses in 29 CFR 5.5 may be grounds for termination of the contract, and for debarment as a contractor and a subcontractor as provided in 29 CFR 5.12.

(8) Compliance with Davis-Bacon and Related Act requirements - All rulings and interpretations of the Davis-Bacon and Related Acts contained in 29 CFR parts 1, 3, and 5 are herein incorporated by reference in this contract.

(9) Disputes concerning labor standards - Disputes arising out of the labor standards provisions of this contract shall not be subject to the general disputes clause of this contract. Such disputes shall be resolved in accordance with the procedures of the Department of Labor set forth in 29 CFR parts 5, 6, and 7. Disputes within the meaning of this clause include disputes between the contractor (or any of its subcontractors) and the contracting agency, the U.S. Department of Labor, or the employees or their representatives.

(10) Certification of eligibility - (i) By entering into this contract, the contractor certifies that neither it (nor he or she) nor any person or firm who has an interest in the contractor's firm is a person or firm ineligible to be awarded Government contracts by virtue of section 3(a) of the Davis-Bacon Act or 29 CFR 5.12(a)(1).

(ii) No part of this contract shall be subcontracted to any person or firm ineligible for award of a Government contract by virtue of section 3(a) of the Davis-Bacon Act or 29 CFR 5.12(a)(1).

(iii) The penalty for making false statements is prescribed in the U.S. Criminal Code, 18 U.S.C. 1001.

4. ACCESS TO RECORDS AND REPORTS - 49 CFR 18.36 [Applicable to all Federal-aid contracts]

Access to Records - The following access to records requirements apply to this Contract:

1. Contractor agrees to provide ARRC, the Federal grantor agency, the Comptroller General, or any of their duly authorized representatives access to the Contractor's books, documents, papers and records which are directly pertinent to this contract for the purpose of making audit, examination, excerpts and transcriptions.

2. Contractor agrees to permit any of the foregoing parties to reproduce by any means whatsoever or to copy excerpts and transcriptions as reasonably needed.

3. Contractor agrees to maintain all books, records, accounts and reports required under this contract for a period of not less than three years after the date of termination or expiration of this contract, except in the event of litigation or settlement of claims arising from the performance of this contract, in which case Contractor agrees to maintain the same until ARRC, the Federal grantor agency, the Comptroller General, or any of their duly authorized representatives, have disposed of all such litigation, appeals, claims or exceptions related thereto.

5. FEDERAL CHANGES - 49 CFR Part 18 [Applicable to all Federal-aid contracts]

Federal Changes - Contractor shall at all times comply with all applicable Federal regulations, policies, procedures and directives, including without limitation those listed directly or by reference in the Agreement between ARRC and the Federal grantor agency, as they may be amended or promulgated from time to time during the term of this contract. Contractor's failure to so comply shall constitute a material breach of this contract.

6. NO GOVERNMENT OBLIGATION TO THIRD PARTIES [Applicable to all Federal-aid contracts]

(1) ARRC and Contractor acknowledge and agree that, notwithstanding any concurrence by the Federal Government in or approval of the solicitation or award of the underlying contract, absent the express written consent by the Federal Government, the Federal Government is not a party to this contract and shall not be subject to any obligations or liabilities to ARRC, Contractor, or any other party (whether or not a party to that contract) pertaining to any matter resulting from the underlying contract.

(2) The Contractor agrees to include the above clause in each subcontract financed in whole or in part with Federal assistance. It is further agreed that the clause shall not be modified, except to identify the subcontractor who will be subject to its provisions.

7. PROGRAM FRAUD AND FALSE OR FRAUDULENT STATEMENTS AND RELATED ACTS - 31 USC 3801 et seq.; 49 CFR Part 31; 18 USC 1001 [Applicable to all Federal-aid contracts]

(1) The Contractor acknowledges that the provisions of the Program Fraud Civil Remedies Act of 1986, as amended, 31 USC §3801 et seq. and U.S. DOT regulations, "Program Fraud Civil Remedies," 49 CFR Part 31, apply to its actions pertaining to this Project. Upon execution of the underlying contract, the Contractor certifies or affirms the truthfulness and accuracy of any statement it has made, it makes, it may make, or causes to be made, pertaining to the underlying contract or the Federally assisted project for which this contract work is being performed. In addition to other penalties that may be applicable, the Contractor further acknowledges that if it makes, or causes to be made, a false, fictitious, or fraudulent claim, statement, submission, or certification, the Federal Government reserves the right to impose the penalties of the Program Fraud Civil Remedies Act of 1986 on the Contractor to the extent the Federal Government deems appropriate.

(2) The Contractor also acknowledges that if it makes, or causes to be made, a false, fictitious, or fraudulent claim, statement, submission, or certification to the Federal Government under a contract connected with a project that is financed in whole or in part with Federal assistance, the Government reserves the right to impose the penalties of 18 USC §1001 on the Contractor, to the extent the Federal Government deems appropriate.

(3) The Contractor agrees to include the above two clauses in each subcontract financed in whole or in part with Federal assistance. It is further agreed that the clauses shall not be modified, except to identify the subcontractor who will be subject to the provisions.

8. SEISMIC SAFETY REQUIREMENTS - 42 USC 7701 et seq. & 49 CFR Part 41 [Applicable only to Federal-aid contracts for the construction of new buildings or additions to existing buildings]

Seismic Safety - The contractor agrees that any new building or addition to an existing building will be designed and constructed in accordance with the standards for Seismic Safety required in Department of Transportation Seismic Safety Regulations, 49 CFR Part 41 and will certify to compliance to the extent required by the regulation. The contractor also agrees to ensure that all work performed under this contract including work performed by a subcontractor is in compliance with the standards required by the Seismic Safety Regulations and the certification of compliance issued on the project.

9. ENERGY CONSERVATION REQUIREMENTS - 42 USC 6321 et seq. & 49 CFR Part 18 [Applicable to all Federal-aid contracts]

Energy Conservation - The Contractor agrees to comply with mandatory standards and policies relating to energy efficiency which are contained in the state energy conservation plan issued in compliance with the Energy Policy and Conservation Act.

10. CIVIL RIGHTS REQUIREMENTS - 29 USC §623, 42 USC §2000, 42 USC §6102, 42 USC §12112, 42 USC §12132, 29 CFR Part 1630, & 41 CFR Parts 60 et seq. [Applicable to all Federal-aid contracts]

Civil Rights - The following requirements apply to the underlying contract:

1. Nondiscrimination - In accordance with Title VI of the Civil Rights Act, as amended, 42 USC §2000d, section 303 of the Age Discrimination Act of 1975, as amended, 42 USC §6102, and section 202 of the Americans with Disabilities Act of 1990, 42 USC §12132, the Contractor agrees that it will not discriminate against any employee or applicant for employment because of race, color, creed, national origin, sex, age, or disability. In addition, the Contractor agrees to comply with applicable Federal implementing regulations and other implementing requirements the Federal grantor agency may issue.

2. Equal Employment Opportunity - The following equal employment opportunity requirements apply to the underlying contract:

(a) Race, Color, Creed, National Origin, Sex - In accordance with Title VII of the Civil Rights Act, as amended, and 42 USC §2000e, the Contractor agrees to comply with all applicable equal employment opportunity requirements of U.S. Department of Labor (U.S. DOL) regulations, "Office of Federal Contract Compliance Programs, Equal Employment Opportunity, Department of Labor," 41 CFR Parts 60 et seq., (which implement Executive Order No. 11246, "Equal Employment Opportunity," as amended by Executive Order No. 11375, "Amending Executive Order 11246 Relating to Equal Employment Opportunity," 42 USC §2000e note), and with any applicable Federal statutes, executive orders, regulations, and Federal policies that may in the future affect construction activities undertaken in the course of the Project. The Contractor agrees to take affirmative action to ensure that applicants are employed, and that employees are treated during employment, without regard to their race, color, creed, national origin, sex, or age. Such action shall include, but not be limited to, the following: employment, upgrading, demotion or transfer, recruitment or recruitment advertising, layoff or termination; rates of pay or other forms of compensation; and selection for training, including apprenticeship. In addition, the Contractor agrees to comply with any implementing requirements the Federal grantor agency may issue.

(b) Age - In accordance with section 4 of the Age Discrimination in Employment Act of 1967, as amended, and 29 USC § 623, the Contractor agrees to refrain from discrimination against present and prospective employees for reason of age. In addition,

the Contractor agrees to comply with any implementing requirements the Federal grantor agency may issue.

(c) Disabilities - In accordance with section 102 of the Americans with Disabilities Act, as amended, 42 USC §12112, the Contractor agrees that it will comply with the requirements of U.S. Equal Employment Opportunity Commission, "Regulations to Implement the Equal Employment Provisions of the Americans with Disabilities Act," 29 CFR Part 1630, pertaining to employment of persons with disabilities. In addition, the Contractor agrees to comply with any implementing requirements the Federal grantor agency may issue.

3. The Contractor also agrees to include these requirements in each subcontract financed in whole or in part with Federal assistance, modified only if necessary to identify the affected parties.

11. NONSEGREGATED FACILITIES - [Applicable to all Federal-aid construction contracts and to all related subcontracts of \$10,000 or more]

1. By submission of this bid, the execution of this contract or subcontract, or the consummation of this material supply agreement or purchase order, as appropriate, the bidder, Federal-aid construction contractor, subcontractor, material supplier, or vendor, as appropriate, certifies that the firm does not maintain or provide for its employees any segregated facilities at any of its establishments, and that the firm does not permit its employees to perform their services at any location, under its control, where segregated facilities are maintained. The firm agrees that a breach of this certification is a violation of the EEO Provisions of this contract. The firm further certifies that no employee will be denied access to adequate facilities on the basis of sex or disability.

2. As used in this certification, the term "segregated facilities" means any waiting rooms, work areas, restrooms and washrooms, restaurants and other eating areas, timeclocks, locker rooms and other storage or dressing areas, parking lots, drinking fountains, recreation or entertainment areas, transportation, and housing facilities provided for employees which are segregated by explicit directive, or are, in fact, segregated on the basis of race, color, religion, or national origin, age or disability, because of habit, local custom, or otherwise. The only exception will be for the disabled when the demands for accessibility override (e.g. disabled parking).

3. The contractor agrees that it has obtained or will obtain identical certification from proposed subcontractors or material suppliers prior to the award of subcontracts or consummation of material supply agreements of \$10,000 or more and that it will retain such certifications in its files.

12. NATIONAL HISTORIC PRESERVATION ACT REQUIREMENTS - 16 USC §470 et seq. [Applicable to all Federal-Aid contracts]

In the performance of this contract, neither Contractor nor its subcontractors shall take any action (which term includes but is not limited to the seeking of any required federal

license or permit, and the extraction of material or natural resources from any source whatsoever) that may affect a district, site, building, structure or object that is included in or eligible for inclusion in the National Register of Historic Places without prior notice to ARRC and compliance with the requirements of the National Historic Preservation Act of 1966, 16 USC § 470 et seq. Contractor is advised that both historic and cultural sites may be eligible for inclusion on the National Register.

13. FLY AMERICA REQUIREMENT - 49 USC §40118; 41 CFR § 301-3.61(b) & 301-10.131 et seq. [Applicable to all Federal-aid contracts which may involve the international air transportation of equipment, materials, commodities, products or personnel]

The Contractor agrees to comply with 49 U.S.C. 40118 (the "Fly America" Act) in accordance with the General Services Administration's regulations at 41 CFR Part 301-10, which provide that recipients and subrecipients of Federal funds and their contractors are required to use U.S. Flag air carriers for U.S Government-financed international air travel and transportation of their personal effects or property, to the extent such service is available, unless travel by foreign air carrier is a matter of necessity, as defined by the Fly America Act. The Contractor shall submit, if a foreign air carrier was used, an appropriate certification or memorandum adequately explaining why service by a U.S. flag air carrier was not available or why it was necessary to use a foreign air carrier and shall, in any event, provide a certificate of compliance with the Fly America requirements. The Contractor agrees to include the requirements of this section in all subcontracts that may involve international air transportation.

14. RECYCLED PRODUCTS - 42 USC §6962; 40 CFR PART 247 [Applicable to all Federal-aid contracts for items designated by the EPA, for the purchase of \$10,000 or more of one of these items during the fiscal year]

The contractor agrees to comply with all the requirements of Section 6002 of the Resource Conservation and Recovery Act (RCRA), as amended (42 USC 6962), including but not limited to the regulatory provisions of 40 CFR Part 247, and Executive Order 12873, as they apply to the procurement of the items designated in Subpart B of 40 CFR Part 247. The contractor agrees to include this requirement in all subcontracts issued pursuant to this contract when the subcontract may involve the purchase of said items.

15. INCORPORATION OF FEDERAL TRANSIT ADMINISTRATION TERMS - FTA Circular 4220.1F [Applicable to all FTA funded contracts]

The provisions herein include, in part, certain Standard Terms and Conditions required by USDOT, whether or not expressly set forth in the contract provisions. All contractual provisions required by USDOT, as set forth in FTA Circular 4220.1F are incorporated by reference. Anything to the contrary herein notwithstanding, all FTA mandated terms shall be deemed to control in the event of a conflict with other provisions contained in this agreement. The contractor shall not perform any act, fail to perform any act, or