

I. EXECUTIVE ORDERS

BJ 12-20 Moratorium on Boards and Commissions Authority to Pay per Diems and Elimination
of Certain Boards 2451

BJ 12-21 Vehicle Expenditure Freeze 2452

II. EMERGENCY RULES

Agriculture and Forestry

Structural Pest Control Commission—Minimum Specifications for Trench and Treat Termite
Control Work (LAC 7:XXV.141) 2453

Wood-Destroying Insect Report and Requests for Rule Changes or Declaratory Rulings
(LAC 7:XXV.101, 121, 165 and 167)..... 2453

Education

Student Financial Assistance Commission, Office of Student Financial Assistance—Scholarship/Grant
Programs—Establishing Eligibility (LAC 28:IV.703) 2455

Health and Hospitals

Bureau of Health Services Financing—Abortion Facilities—Licensing Standards
(LAC 48:I.4403, 4409, and 4415) 2457

Adult Dentures Program—Reimbursement Rate Reduction (LAC 50:XXV.701) 2458

All Inclusive Care for the Elderly—Reimbursement Rate Reduction (LAC 50:XXIII.1301)..... 2459

Ambulatory Surgical Centers—Reimbursement Rate Reduction (LAC 50:XI.7503)..... 2460

Behavioral Health Services—Statewide Management Organization—Adults Capitated Payment
Reduction (LAC 50:XXXIII.501)..... 2460

Children’s Behavioral Health Services—Reimbursement Rate Reduction (LAC 50:XXXIII.2701)..... 2461

Early and Periodic Screening, Diagnosis and Treatment—Dental Program—Reimbursement Rate
Reduction (LAC 50:XV.6905) 2462

Early and Periodic Screening, Diagnosis and Treatment—School-Based Nursing Services
(LAC 50:XV.Chapter 95) 2463

End Stage Renal Disease Facilities—Reimbursement Rate Reduction (LAC 50:XI.6901 and 6903) 2465

Family Planning Clinics—Reimbursement Rate Reduction (LAC 50:XI.3501) 2466

Family Planning Waiver—Reimbursement Rate Reduction (LAC 50:XXII.2701) 2467

Home and Community-Based Services Waivers—Adult Day Health Care—Reimbursement Rate
Reduction (LAC 50:XXI.2915)..... 2467

Home and Community-Based Services Waivers—Cost Reporting Requirements
(LAC 50:XXI.Chapter 7)..... 2468

Home and Community-Based Services Waivers—Repeal of Standards for Participation
(LAC 50:XXI.Chapter 1)..... 2469

Home and Community-Based Services Waivers—Residential Options Waiver—Reimbursement
Rate Reduction (LAC 50:XXI.16901)..... 2469

Home and Community-Based Services Waivers—Supports Waiver—Reimbursement Rate Reduction
(LAC 50:XXI.6101) 2470

Home Health Program—Durable Medical Equipment—Reimbursement Rate Reduction
(LAC 50:XIII.10301)..... 2471

Home Health Program—Nursing and Home Health Aide Services—Reimbursement Rate Reduction
(LAC 50:XIII.701)..... 2472

Home Health Services—Cost Reporting Requirements (LAC 50:XIII.Chapter 1)..... 2472

Hospice Services (LAC 50:XV.3301, Chapter 35, 3701, 3703, 3901, 4101, Chapter 43) 2473

Inpatient Hospital Services—Major Teaching Hospitals—Supplemental Payments (LAC 50:V.1333)..... 2476

Inpatient Hospital Services—Major Teaching Hospitals—Qualifying Criteria (LAC 50:V.1301-1309)..... 2477

Inpatient Hospital Services—Non-Rural, Non-State Public Hospitals—Reimbursement Methodology
(LAC 50:V.963)..... 2479

This public document was published at a total cost of \$2400. Five hundred copies of this public document were published in this monthly printing at a cost of \$2400. The total cost of all printings of this document including reprints is \$2400. This document was published by Moran Printing, Inc. 5425 Florida Boulevard, Baton Rouge, LA 70806, as a service to the state agencies in keeping them cognizant of the new rules and regulations under the authority of R.S. 49:950-971 and R.S. 49:981-999. This material was printed in accordance with standards for printing by state agencies established pursuant to R.S. 43:31. Printing of this material was purchased in accordance with the provisions of Title 43 of the Louisiana Revised Statutes.

The Office of the State Register provides auxiliary aids for the *Louisiana Register* for visually impaired individuals. By appointment, oral presentation of the *Register* is available at the Office of the State Register, or an audiocassette tape of requested sections of the *Register* can be provided for the cost incurred by the Office of the State Register in producing such a tape. For more information contact the Office of the State Register.

Inpatient Hospital Services—Reimbursement Methodology—Medical Education Payments (LAC 50:V.551, 967 and 1331).....	2480
Intermediate Care Facilities for Persons with Developmental Disabilities—Reimbursement Rate Reduction (LAC 50:VII.32903)	2481
Laboratory and Radiology Services—Reimbursement Rate Reduction (LAC 50:XIX.4329 and 4334-4337)	2482
LaCHIP Affordable Plan—Dental Program—Reimbursement Rate Reduction (LAC 50:III.20509).....	2483
Medical Transportation Program—Emergency Ambulance Services—Reimbursement Rate Reduction (LAC 50:XXVII.325 and 353)	2484
Medical Transportation Program—Emergency Ambulance Services—Supplemental Payments (LAC 50:XXVII.327 and 355).....	2485
Nursing Facilities—Reimbursement Methodology—Low Income and Needy Care Collaboration (LAC 50:II.20023).....	2487
Nursing Facilities—Reimbursement Rate Reduction—Post-Rebase Rate Cut (LAC 50:II.20005)	2488
Nursing Facilities—Reimbursement Rate Reduction—Pre-Rebase Rate Cut (LAC 50:II.20005).....	2489
Nursing Facilities—Reimbursement Methodology—Private Room Conversions (LAC 50:II.20010).....	2490
Outpatient Hospital Services—Non-Rural, Non-State Public Hospitals—Supplemental Payments (LAC 50:V.5315, 5515, 5717, 5915 and 6117)	2490
Outpatient Hospital Services—State-Owned Hospitals—Medical Education Payments (LAC 50:V.5319, 5519, 5919 and 6127).....	2492
Pediatric Day Health Care Program—Reimbursement Rate Reduction (LAC 50:XV.28101).....	2493
Personal Care Services—Long Term—Cost Reporting Requirements (LAC 50:XV.12919).....	2494
Personal Care Services—Long Term—Reimbursement Rate Reduction (LAC 50:XV.12917)	2495
Pregnant Women Extended Services—Dental Services—Reimbursement Rate Reduction (LAC 50:XV.16107).....	2495
Professional Services Program—Anesthesia Services—Reimbursement Rate Reduction (LAC 50:IX.15133 and 15135).....	2496
Professional Services Program—Family Planning Services—Reimbursement Rate Reduction (LAC 50:IX.15143).....	2497
Professional Services Program—Physician Services—Reclassification of Optometry Services (LAC 50:IX.15111 and 15113)	2498
Professional Services Program—Physician Services—Reimbursement Rate Reduction (LAC 50:IX.15113).....	2499
Prosthetics and Orthotics—Reimbursement Rate Reduction (LAC 50:XVII.501).....	2500
Substance Abuse Services—Reimbursement Rate Reduction (LAC 50:XXXIII.14701)	2501
Targeted Case Management—Reimbursement Rate Reduction (LAC 50:XV.10701)	2502
Uncompensated Care Payments (LAC 50:I.Chapter 13).....	2502
Licensed Professional Vocational Rehabilitation Counselors Board of Examiners—Practice of Mental Health Counseling for Serious Mental Illnesses (LAC 46:LX.505).....	2503
Office for Citizens with Developmental Disabilities—Home and Community-Based Services Waivers Residential Options Waiver—Reimbursement Rate Reduction (LAC 50:XXI.16901).....	2469
Home and Community-Based Services Waivers—Supports Waiver—Reimbursement Rate Reduction (LAC 50:XXI.6101)	2470
Office of Aging and Adult Services—All Inclusive Care for the Elderly—Reimbursement Rate Reduction (LAC 50:XXIII.1301)	2459
Home and Community-Based Services Waivers—Adult Day Health Care—Reimbursement Rate Reduction (LAC 50:XXI.2915).....	2467
Home and Community-Based Services Waivers—Repeal of Standards for Participation (LAC 50:XXI.Chapter 1).....	2469
Personal Care Services—Long Term—Reimbursement Rate Reduction (LAC 50:XV.12917)	2495
Office of Behavioral Health—Behavioral Health Services—Statewide Management Organization Adults Capitated Payment Reduction (LAC 50:XXXIII.501)	2460
Children’s Behavioral Health Services—Reimbursement Rate Reduction (LAC 50:XXXIII.2701).....	2461
Substance Abuse Services—Reimbursement Rate Reduction (LAC 50:XXXIII.14701)	2501
Office of Public Health—Review and Approval of Plans and Specifications for Issuance of a Permit for a Potable Water Supply (LAC 51:XII.105).....	2504
Uncompensated Care Payments (LAC 50:I.Chapter 13).....	2502
Natural Resources	
Office of Conservation—Statewide Orders No. 29-B and 29-B-A—Deadline of Drilling and Completion Operational and Safety Requirements for Wells Drilled in Search or for the Production of Oil or Natural Gas at Water Locations	2505
State	
Elections Division—Emergency Election Day Paper Ballot Procedures (LAC 31:I.Chapter 11).....	2516

Transportation and Development	
Office of Operations—Special Permit for Vehicles Hauling Sugarcane (LAC 73:I.303).....	2519
Wildlife and Fisheries	
Wildlife and Fisheries Commission—2012-13 Deer Season Rules and Regulations—Adjustment	2519
East Zone Alligator Season Extension	2520
III. RULES	
Agriculture and Forestry	
Feed, Fertilizer and Agricultural Liming Commission—Feed, Fertilizer, and Agricultural Liming (LAC 7:XI.Chapter 1, XVII.Chapter 1, and XXIX.101).....	2521
Economic Development	
Office of the Secretary, Office of Business Development—Economic Development Award Program (EDAP), Economic Development Loan Program (EDLOP), and Economic Development Site Readiness Program (EDRED) (LAC 13:III.151, 153 and 155).....	2528
Governor	
Board of Home Inspectors—Education, Standards of Practice, Rehearing Procedure (LAC 46:XL.119, 120, 121, 303, 305, 309, 313, 315, 319, 321, 325, and 713).....	2529
Division of Administration, Patient’s Compensation Fund Oversight Board—Patient’s Compensation Fund (LAC 37:III.Chapters 1-19).....	2533
Division of Administration, Racing Commission—Field Less Than Five (LAC 35:XIII.11115)	2548
Superfecta (LAC 35:XIII.11701)	2549
Health and Hospitals	
Board of Nursing—Procedure for Establishing a New Program (LAC 46:XLVII.3533)	2549
Louisiana Economic Development Corporation	
Louisiana Economic Development Corporation—Economic Development Award Program (EDAP), Economic Development Loan Program (EDLOP), and Economic Development Site Readiness Program (EDRED) (LAC 13:III.151, 153 and 155).....	2528
Public Safety and Corrections	
Office of State Police—Motor Vehicle Inspections (LAC 55:III.Chapters 7 and 8).....	2550
Operator Qualifications (LAC 55:I.503)	2562
Transportation and Development	
Professional Engineering and Land Surveying Board—Examinations and Experience (LAC 46:LXI.707, 709, 901, 903, 907, 909, 1301, 1509 and 1701).....	2563
Wildlife and Fisheries	
Office of the Secretary—Wild Seafood Certification Program (LAC 76:I.709)	2566
Wildlife and Fisheries Commission—Calcasieu Lake Oyster Harvester Permit (LAC 76:VII.533)	2567
Yo-Yo and Trotline Regulations (LAC 76:VII.134).....	2567
IV. NOTICES OF INTENT	
Agriculture and Forestry	
Office of Agriculture and Environmental Sciences—Definition for the Advisory Commission on Pesticides (LAC 7:XXIII.103).....	2569
Assessors’ Retirement Fund	
Board of Trustees of the Assessors’ Retirement Fund—Assessors’ Retirement Fund (LAC 58:XIX.Chapters 1-7)	2570
Children and Family Services	
Division of Programs, Licensing Section—Penalty for the Operation of an Unlicensed Facility (LAC 67:III.7302, 7355 and V.6704, 6953, 7103 and 7303)	2575
Economic Stability—Child Welfare Emergency Assistance Services Program (LAC 67:III.5597)	2575
Culture, Recreation and Tourism	
Office of the State Library—Cultural Resources (LAC 25:VII.Chapters 1, 3, 5, 13, 23, 27, 31, 41, 43, 45, 51, and 53)	2578
Education	
Board of Elementary and Secondary Education—Bulletin 118—Statewide Assessment—Standards and Practices (LAC 28: CXI, 319, 701, 1701, 1805, 1807, 1808, 1809, 1810, 1813, 1817, 1825, 2201, 2203, 2205, 2207, 2400, 2409, 2411, 2412, 2413, and 2415).....	2584
Bulletin 119—Louisiana School Transportation Specifications and Procedures (LAC 28: CXIII.Chapters 3, 19 and 31)	2590
Bulletin 126—Charter Schools—Application Process (LAC 28:CXXXIX.512).....	2592
Bulletin 129—The Recovery School District (LAC 28:CXLV.505).....	2594
Board of Regents—Registration and Licensure (LAC 28:IX.103 and 105).....	2595
Student Financial Assistance Commission, Office of Student Financial Assistance—TOPS GPA Calculation (LAC 28:IV.301).....	2596

Governor

Division of Administration, Office of Facility Planning and Control—Capital Improvement
Projects—Louisiana Building Code (LAC 34:III.131) 2597

Health and Hospitals

Bureau of Health Services Financing—Coordinated Care Network—Pharmacy Services Coverage
(LAC 50:I.3503-3509) 2598
Early and Periodic Screening, Diagnosis and Treatment Uncompensated Care Payments
(LAC 50:XV.Chapter 97) 2600
Family Planning Clinics—Reimbursement Methodology—Office of Public Health Uncompensated
Care Payments (LAC 50:XI.3501) 2601
Inpatient Hospital Services—Distinct Part Psychiatric Units—Reimbursement Methodology
(LAC 50:V.915 and 959) 2602
Laboratory Services—Office of Public Health Uncompensated Care Payments (LAC 50:XIX.4329) 2604
Pharmacy Benefits Management Program—Methods of Payment (LAC 50:XXIX.105 and Chapter 9) 2605
Professional Services Program—Family Planning Services—Uncompensated Care Payments
(LAC 50:IX.15143) 2608
Professional Services Program—Immunizations—Uncompensated Care Payments
(LAC 50:IX.8305, 8505 and 8701) 2609
Targeted Case Management—Nurse Family Partnership Program—Uncompensated Care
Payments (LAC 50:XV.10701) 2611
Office of Public Health—Early and Periodic Screening, Diagnosis and Treatment—Uncompensated
Care Payments (LAC 50:XV.Chapter 97) 2600
Professional Services Program—Family Planning Services—Uncompensated Care Payments
(LAC 50:IX.15143) 2608
Professional Services Program—Immunizations—Uncompensated Care Payments
(LAC 50:IX.8305, 8505 and 8701) 2609
Targeted Case Management—Nurse Family Partnership Program—Uncompensated Care
Payments (LAC 50:XV.10701) 2611

Public and Safety and Corrections

Board of Pardons, Committee on Parole, Committee on Parole—Membership, Duties, and Functions
(LAC 22:XI.101-122, 501-514, 701-711, 901, 903, 907, 909, 911, 1501, and 1503) 2612
Office of Motor Vehicles—Veterans Driver's License (LAC 55:III.110) 2624
Office of State Police—Special Permit for Vehicles Hauling Sugarcane (LAC 73:I.303) 2632

Revenue

Policy Services Division—Corporation Income and Franchise Tax Filing Extensions (LAC 61:III.2503) 2625
Income and Franchise Tax (LAC 61:I.1520) 2626
Income—Withholding Tax (LAC 61:I.1516) 2627
Individual Income Tax Filing Extensions (LAC 61:III.2501) 2628

Transportation and Development

Office of Highways/Engineering—Design-Build Pilot Program Repeal (LAC 70:I.Chapter 7) 2629
Office of Multimodal Planning—Port Design-Build Pilot Program (LAC 56:III.Chapter 23) 2631
Office of Operations—Special Permit for Vehicles Hauling Sugarcane (LAC 73:I.303) 2632

Treasury

Board of Trustees of the Louisiana State Employees' Retirement System—Election to the Board of
Trustees (LAC 58:I.401, 405, and 407) 2633
Plan Year; Limitations Year (LAC 58:I.115, 117) 2635

Wildlife and Fisheries

Wildlife and Fisheries Commission—Falconry (LAC 76:V.301) 2636

Workforce Commission

Office of Workers' Compensation—Electronic Medical Billing and Payment Companion Guide
(LAC 40:I.305 and 306) 2643

V. ACU

Cumulative—January 2012 through September 2012 2664

VI. POTPOURRI

Agriculture and Forestry

Horticulture Commission—Landscape Architect State Exam 2667

Education

Board of Elementary and Secondary Education—Bulletin 133—Scholarship Programs
(LAC 28:CLIII.1301-1305) 2667

Health and Hospitals

Office of Public Health—Public Hearing—Substantive Changes to Proposed Rule
Amendments—Accreditation of Laboratories Conducting Drinking Water Analyses
(LAC 48:V.Chapter 80 and LAC 51:XII.101.301) 2667

Natural Resources

Office of the Secretary, Fishermen's Gear Compensation Fund—Underground Obstruction

Latitude/Longitude Coordinates..... 2670

Public Safety and Corrections

Oil Spill Coordinator's Office—Request for Comments—Deepwater Horizon Oil Spill—Draft Phase II Early

Restoration Plan and Environmental Assessment 2670

VII. INDEX 2672

Executive Orders

EXECUTIVE ORDER BJ 12-20

Moratorium on Boards and Commissions Authority to Pay per Diems and Elimination of Certain Boards

WHEREAS, Executive Order BJ 2012-9 froze payment of a per diem to members of boards, commissions, and like entities funded by the General Appropriation Act. However, over the years, many boards, commissions and like entities that have been statutorily created in the executive branch of state government with budget authority do not receive annual appropriation approval via the General Appropriation Act;

WHEREAS, more than 80 boards, commissions, authorities, task forces, advisory councils, committees, and like entities have been established with a statutory mandate requiring payment of a per diem;

WHEREAS, approximately 300 additional boards, commissions, authorities, task forces, advisory councils, committees or like entities have been established that permit discretionary payment of per diems, are silent as to such payments but may grant implied budgetary authority to authorize such payments, or provide that no compensation shall be paid to members of such entities;

WHEREAS, continuing to pay a per diem is a drain on state funds and places a fiscal burden upon individuals, businesses, or other entities that fund the operations of boards, commissions, or like entities;

WHEREAS, a moratorium on the payment of a per diem is necessary to decrease this fiscal burden and is proper to ensure boards, commissions, authorities, task forces, advisory councils, committees, and like entities are functioning in a fiscally prudent manner consistent with those that are included in the General Appropriations Act; and

WHEREAS, the purpose of this Order is to freeze per diem payments, withhold appropriations for per diem payments, and limit expenditures for a per diem in the executive branch of state government, which will result in approximately \$275,000 savings this fiscal year;

NOW THEREFORE I, BOBBY JINDAL, Governor of the State of Louisiana, by virtue of the authority vested by the Constitution and laws of the State of Louisiana, do hereby order and direct as follows:

SECTION 1: Expenditures for per diem payments by members of all boards, commissions, authorities, task forces, advisory councils, or committees in the executive branch of state government are hereby suspended, including any that may hold funds in accounts other than the State Treasury, except as otherwise provided in this Order.

SECTION 2: The Commissioner of Administration and any executive or fiscal officer for any board, commission, authority, task force or committee in the

executive branch of state government are hereby directed to withhold all funds for payment of per diem.

SECTION 3: The Treasurer shall not honor warrants drawn upon the State Treasury that are inconsistent with this Order, and no executive or fiscal officer of any board, commission, authority, task force, or committee in the executive branch of state government shall approve any request for an expenditure that is inconsistent with this Order.

SECTION 4: Per diem payments that are expressly and directly statutorily mandated are exempt from this Order. The Commissioner of Administration is hereby authorized to grant further exemptions as may be necessary due to extreme economic hardships which would otherwise result to a member of a board, commission, authority, task force, advisory council, committee or like entity.

SECTION 5: All boards, commissions, authorities, task forces, advisory councils, committees, and like entities in the executive branch of state government, including any that may hold funds in accounts other than the State Treasury, must comply with the following directives:

A. By August 1 of each year, all boards, commissions, authorities, task forces, advisory councils, committees, and like entities shall report to the Commissioner of Administration the total amount of funds collected and expended by the entity during the prior fiscal year.

B. By the end of each month, any entity expressly and directly mandated to pay a per diem or granted a hardship exemption for any member by the Commissioner pursuant to Section 4 shall report to the Commissioner of Administration the total amount of funds expended by the entity on per diem during the prior month and by August 1 of each year, report to the Commissioner of Administration the total amount of funds expended by the entity on per diem during the prior fiscal year.

SECTION 6: The following entities are hereby terminated:

A. The E-Rate Oversight Committee as re-established by BJ 2008-52;

B. The Maritime Advisory Task Force as re-established by BJ 2008-42;

C. The Interstate 49 North Extension Feasibility and Funding Task Force as re-established by BJ 2008-44; and

D. The Governor's Military Advisory Board as re-established by BJ 2010-17.

SECTION 7: This Order shall supersede all prior Executive Orders not consistent herewith.

SECTION 8: This Order is effective upon signature of the Governor and shall remain in effect until amended, modified, terminated or rescinded by the Governor, or terminated by operation of law.

IN WITNESS WHEREOF, I have set my hand officially and caused to be affixed the Great Seal of Louisiana, at the Capitol, in the city of Baton Rouge, on this 14th day of September, 2012.

Bobby Jindal
Governor

ATTEST BY
THE GOVERNOR
J. Thomas Schedler
Secretary of State
1210#113

EXECUTIVE ORDER BJ 12-21

Vehicle Expenditure Freeze

WHEREAS, pursuant to the provisions of Article IV, Section 5 of the Louisiana Constitution of 1974, as amended, the Governor may issue executive orders which limit the expenditure of funds by the various agencies in the executive branch of State government (hereafter "vehicle expenditure freeze"); and

WHEREAS, the State must always be fiscally responsible with taxpayer dollars.

NOW THEREFORE, I, BOBBY JINDAL, Governor of the State of Louisiana, by virtue of the authority vested by the Constitution and the laws of the State of Louisiana, do hereby order and direct as follows:

SECTION 1: No department, agency, and/or budget unit of the executive branch of the State of Louisiana, unless specifically exempted with the written approval of the Commissioner of Administration, shall make any expenditure of funds related to the acquisition or long term leasing of new and/or used vehicles; this shall not affect the ability of those bodies to utilize the vehicle rental contract, without the approval of the commissioner, when necessary to conduct official State business.

SECTION 2: All departments, commissions, boards, offices, entities, agencies, and officers of the State of Louisiana, or any political subdivision thereof, are authorized and directed to cooperate in the implementation of the provisions of this Order.

SECTION 3: This Order is effective upon signature and shall remain in effect through June 30, 2013, unless amended, modified, terminated, or rescinded prior to that date.

IN WITNESS WHEREOF, I have set my hand officially and caused to be affixed the Great Seal of Louisiana, at the Capitol, in the city of Baton Rouge, on this 4th day of October, 2012.

Bobby Jindal
Governor

ATTEST BY
THE GOVERNOR
J. Thomas Schedler
Secretary of State
1210#114

Emergency Rules

DECLARATION OF EMERGENCY

Department of Agriculture and Forestry Structural Pest Control Commission

Minimum Specifications for Trench and Treat Termite Control Work (LAC 7:XXV.141)

In accordance with the emergency provisions of the Administrative Procedure Act, R.S. 49:953 (B), and under the authority of R.S. 3:3366, the Structural Pest Control Commission (SPCC) declares an emergency to exist and requests the adoption by emergency process the attached regulations to supersede the current permanent regulations found at LAC 7:XXV.141. The regulations being put into place by this declaration of emergency are in the process of being promulgated as permanent rules and are anticipated to become effective upon completion of promulgation. The implementation of these regulations by the emergency process is necessary in order to require pest control operators in Louisiana who use termiticides approved by the SPCC, to calculate the termiticide and water mixture for a minimum of a 12 inch depth application in the trench when using the trench and treat requirements on the termiticide labels. The implementation of these Rules will clarify label requirements that have been industry standards and used in this fashion for many years, but were not specifically required on the federal labels or by the SPCC rules. Louisiana has a significant Formosan Subterranean Termite (FST) population. FST cause tremendous damage to homes each year. This Rule will assure homeowners and other structure owners that they are obtaining the best scientific protection. With this Rule change, the Department and the SPCC are continuing to protect the public by preventing homes and other structures from infestation by subterranean termites.

This Emergency Rule becomes effective on the signature of the Commissioner, October 3, 2012, and shall remain in effect for 120 days, unless renewed or until the permanent rules and regulations become effective.

Title 7

AGRICULTURE AND ANIMALS

Part XXV. Structural Pest Control

Chapter 1. Structural Pest Control Commission

§141. Minimum Specifications for Termite Control Work

A. - A.2. ...

B. Requirements for Trench and Treat

1. Calculations made for the rate and volume of the termiticide mixture being applied in all trenches shall be based on a minimum of one foot of depth.

2. All trenches shall be a minimum of four inches wide at the top angled toward the foundation and a minimum of six inches deep in order to permit application of the required chemical.

3. Application of the product mixture into the trench shall be made at the rate and manner prescribed on the label and labeling.

4. Rodding shall be acceptable only when trenching will damage irrigation equipment, flowers and/or shrubs.

C. - I.2.c. ...

3. The requirements specified in Section 141. B.1 through 3 shall not be waived.

J. - M.9. ...

AUTHORITY NOTE: Promulgated in accordance with R.S. 3:3366.

HISTORICAL NOTE: Promulgated by the Department of Agriculture, Structural Pest Control Commission, LR 11:330 (April 1985), amended by the Department of Agriculture and Forestry, Structural Pest Control Commission, LR 15:958 (November 1989), LR 20:644 (June 1994), LR 21:931 (September 1995), LR 23:1285 (October 1997), LR 25:235 (February 1999), LR 25:1620 (September 1999), LR 26:2437 (November 2000), LR 27:1180 (August 2001), LR 29:1063 (July 2003), LR 30:1145 (June 2004), repromulgated LR 30:1614 (August 2004), amended LR 35:207 (February 2009), LR 35:1469 (August 2009), repromulgated LR 35:1872 (September 2009), amended, LR 37:286 (January 2011), LR 38:

Mike Strain DVM
Commissioner

1210#016

DECLARATION OF EMERGENCY

Department of Agriculture and Forestry Structural Pest Control Commission

Wood-Destroying Insect Report and Requests for Rule Changes or Declaratory Rulings (LAC 7:XXV.101, 121, 165 and 167)

In accordance with the emergency provisions of the Administrative Procedure Act, R.S. 49:953 (B), and under the authority of R.S. 3:3203, the Commissioner of Agriculture and Forestry declares an emergency to exist and requests the adoption by emergency process the attached regulations to supersede the current permanent regulations found at LAC 7:XXV.101 and 121. The regulations being put into place by this declaration of emergency are in the process of being promulgated as permanent rules and are anticipated to become effective upon completion of promulgation. The implementation of these regulations by the emergency process is necessary in order to afford pest control operators in Louisiana the ability to seek a ruling from the commission regarding any law or rule under the purview of the commission. Permitting the pest control operators to clarify any laws or regulations will offer the public protection from potentially harmful applications of termiticides. Under the current regulations, there is not a process in which a pest control operator may seek relief

from the commission. The implementation of these rules will allow pest control operators to petition for a rule change or declaratory relief which will offer an administrative due process avenue in which pest control operators may seek guidance. The implementation of these rules will additionally clarify provisions related to Wood Destroying Insect Reports thereby protecting the consumers from reliance on the reports.

This Emergency Rule becomes effective on the signature of the commissioner, September 26, 2012, and shall remain in effect for 120 days, unless renewed or until the permanent rules and regulations become effective.

Title 7

AGRICULTURE AND ANIMALS

Part XXV. Structural Pest Control

Chapter 1. Structural Pest Control Commission

§101. Definitions

A. - B. ...

* * *

Rule—as defined in R.S. 49:951(6).

Wood Destroying Insect Report—a document approved by the Structural Pest Control Commission issued by a pest control operator only for inspections made to determine the presence of wood destroying insects for acts of sale or refinance of structures. A wood destroying insect report shall not be renewable or issued for any other purpose.

AUTHORITY NOTE: Promulgated in accordance with R.S. 3:3362.

HISTORICAL NOTE: Promulgated by the Department of Agriculture, Structural Pest Control Commission, LR 11:323 (April 1985), amended by the Department of Agriculture and Forestry, Structural Pest Control Commission LR 15:954 (November 1989), 17:251 (March 1991), LR 23:855 (July 1997), LR 30:1143 (June 2004), amended by the Department of Agriculture and Forestry, Office of Agriculture and Environmental Sciences, LR 31:26 (January 2005), amended by the Department of Agriculture and Forestry, Structural Pest Control Commission, LR 32:796 (May 2006), repromulgated LR 32:1015 (June 2006), amended LR 33:39 (January 2007), LR 35:204 (February 2009), LR 35:1468 (August 2009), LR 37:272 (January 2011), LR 38:

§121. Wood Destroying Insect Report

A. A wood destroying insect report approved by the commission shall be issued only for inspections made to determine the presence of wood destroying insects for acts of sale or refinance of structures. A wood destroying insect report shall not be renewable or issued for any other purpose.

B. A wood destroying insect report shall be issued by a person who is licensed by the commission in termite control or a certified WDIR technician who is working under the supervision of a person who is licensed by the commission in termite control. The report shall carry a guarantee that the property will be treated without charge should live wood destroying insects covered by the report be found within 90 days from the date of inspection. The presence of frass will be acceptable as evidence of a live infestation of power post beetles; however, frass shall be exuding or streaming from the holes on the outside of the wood.

B.1. - D.2. ...

AUTHORITY NOTE: Promulgated in accordance with R.S. 3:336.

HISTORICAL NOTE: Promulgated by the Department of Agriculture, Structural Pest Control Commission, LR 12:285 (May 1986), amended by the Department of Agriculture and Forestry, Structural Pest Control Commission, LR 23:856 (July 1997), LR 24:631 (April 1998), LR 25:235 (February 1999), LR 25:829 (May 1999), amended by the Department of Agriculture and Forestry, Office of Agriculture and Environmental Sciences, LR 31:26 (January 2005), amended by the Department of Agriculture and Forestry, Structural Pest Control Commission, LR 32:797 (May 2006), repromulgated LR 32:1017 (June 2006), amended LR 37:282 (January 2011), LR 38:

§165. Requests for Adoption, Amendment, or Repeal of a Rule

A. Any interested person may, pursuant to R.S. 49:953(C), request the commission to adopt, amend, or repeal a rule (rule change) that the commission has the authority to make.

B. A request for a rule change shall be in writing and shall contain the following information.

1. A draft of the proposed wording of the requested rule change or a statement detailing the content of the requested rule change.

2. The name, address, telephone number, fax number and e-mail address of the requesting party.

C. The request for a rule change shall be addressed to the commission and shall be mailed or delivered to 5825 Florida Boulevard, Baton Rouge, LA 70806.

D. The commission shall consider the request as follows:

1. A request for rule change shall be considered by the commission within a reasonable time, not to exceed 90 days.

a. Notice of the meeting at which the request is to be considered shall be provided to the person submitting the request.

b. Failure of the requesting party to attend the meeting for purposes of discussing the proposed rule change may be cause for the request to be denied by the commission.

c. The request, with the consent of the requesting party, may be taken under consideration or action deferred pending further information. If the matter is taken under consideration or action is deferred then it will be taken up again at the next regularly scheduled meeting of the commission or at a special meeting.

E. Any decision by the commission shall be in writing and shall state the reasons for the denial or action. Such notice may be delivered by hand, mail, electronically or by any other means reasonably assured to provide notice to the requesting party.

AUTHORITY NOTE: Promulgated in accordance with R.S. 3:3366 and R.S. 49:953(C).

HISTORICAL NOTE: Promulgated by the Department of Agriculture, Structural Pest Control Commission, LR 38:

§167. Procedures for Declaratory Orders and Rulings

A. This rule provides for the filing and prompt disposition of requests for declaratory orders and rulings as to the applicability of any statutory provision or as to the applicability of any rule or order of the commission, as required by R.S.49:962 and 49:963(D).

B. A request for a declaratory order or ruling shall be in writing and shall contain the following information.

1. A citation to the specific statutory provision, rule or order that will be the subject of the declaratory order or ruling.

2. A concise statement of why the declaratory order or ruling is being requested.

3. A list of all persons that the requesting party may call to testify and a list of all documents that may be submitted as evidence, if a hearing is called to take evidence.

4. The name, address, telephone number, fax number and e-mail address of the requesting party, either printed or written in legible form.

C. The request for a declaratory order or ruling shall be addressed to the commission and shall be mailed or delivered to 5825 Florida Boulevard, Baton Rouge, LA 70806.

D. The commission shall consider the request as follows.

1. The request shall be considered by the commission within a reasonable time, not to exceed 90 days.

2. Notice of the meeting at which the request is to be considered shall be provided to the person submitting the request.

E. The commission's decision shall be sent to the requesting party either by certified mail, return receipt requested; hand delivery; or commercial courier.

F. Failure of the requesting party, after notice, to attend any hearing or meeting regarding the request may be cause for the request to be denied.

AUTHORITY NOTE: Promulgated in accordance with R.S. 3:3366 and R.S. 49:953(C).

HISTORICAL NOTE: Promulgated by the Department of Agriculture, Structural Pest Control Commission, LR 38:

Mike Strain DVM
Commissioner

1210#008

DECLARATION OF EMERGENCY

Student Financial Assistance Commission Office of Student Financial Assistance

Scholarship/Grant Programs—Establishing Eligibility (LAC 28:IV.703)

The Louisiana Student Financial Assistance Commission (LASFAC) is exercising the emergency provisions of the Administrative Procedure Act [R.S. 49:953(B)] to amend and re-promulgate the rules of the Scholarship/Grant programs [R.S. 17:3021-3025, R.S. 3041.10-3041.15, and R.S. 17:3042.1.1-3042.8, R.S. 17:3048.1, R.S. 56:797.D(2)].

This rulemaking revises and adds courses to the list of courses that may be used by students at the Louisiana School for Math, Science and the Arts as courses equivalent to the courses in the Taylor Opportunity Program for Students (TOPS) core curriculum.

This Declaration of Emergency is effective September 20, 2012, and shall remain in effect for the maximum period allowed under the Administrative Procedure Act. (SG13143E)

Title 28

EDUCATION

Part IV. Student Financial Assistance—Higher Education—Scholarship and Grant Programs

Chapter 7. Taylor Opportunity Program for Students (TOPS) Opportunity, Performance, and Honors Awards

§703. Establishing Eligibility

A. - A.5.a.ii(d). ...

iii.(a). Through academic year (high school) 2011-2012, for purposes of satisfying the requirements of §703.A.5.a.i above, in addition to the courses identified in §703.A.5.a.ii, the following courses shall be considered equivalent to the identified core courses and may be substituted to satisfy corresponding core courses for students of the Louisiana School for Math, Science and the Arts.

Core Curriculum Course	Equivalent (Substitute) Course
English III	EN 210 Composition/Major Themes in Literature (1 unit)
English IV	Any 2 of the following 1/2 unit courses: EN 311 Readings in Literature (at least one 311 course is a requirement) EN 311A American Literature EN 311B British Literature EN 302 Studies in the English Language EN 304 Topics in American and British Literature EN 312 Studies in Poetry EN 314 Readings in World Literature EN 322 Studies in Fiction EN 332 Introduction to Film Studies EN 342 Studies in Modern Drama EN 401 Creative Writing EN 402 Expository Writing EN 412 Studies in a Major Author— Shakespeare EN 422 Studies in a Major Author— Faulkner IS 314 Dramatic Text and Performance IS 315 Literature and Science IS 317 Evolution and Literature IS 318 Sacred Literature IS 411 English Renaissance
Algebra I (one unit)	Any combination of advanced math courses which equal 1 unit of course credit that are certified by the school to be equivalent of Algebra I
Algebra II (one unit)	Any combination of advanced math courses which equal 1 unit of course credit that are certified by the school to be equivalent of Algebra II: MA 120 College Algebra (1 unit), or MA 121 Accelerated College Algebra (1/2 unit) and 1/2 unit of MA 203 Trigonometry

Core Curriculum Course	Equivalent (Substitute) Course
Physics	PH 110L Conceptual Physics (1 unit), or PH 210L General Physics (1 unit), or PH 250L Advanced Placement Physics (1 unit), or PH 310L Physics with Calculus
Biology II	BI 210L Advanced Placement Biology (1 unit), or BI 231L Microbiology (1/2 unit), and BI 241 Molecular and Cellular Biology (1/2 unit)
Civics (1/2 unit) and Free Enterprise (1/2 unit)	AH 243 American Government and Politics (1/2 unit), and SS 113 Economics (1/2 unit)
Western Civilization	EH 121 Ancient and Medieval History (1/2 unit) and EH 122 Modern History (1/2 unit)
*Applied Mathematics III was formerly referred to as Applied Geometry **Advanced Math—Pre-Calculus was formerly referred to as Advanced Mathematics II ***Advanced Math—Functions and Statistics was formerly referred to as Advanced Mathematics II	

(b). Beginning with the academic year (high school) 2011-2012, for purposes of satisfying the requirements of §703.A.5.a.i above, in addition to the courses identified in §703.A.5.a.ii, the following courses shall be considered equivalent to the identified core courses and may be substituted to satisfy corresponding core courses for students of the Louisiana School for Math, Science and the Arts.

Core Curriculum Course	Equivalent (Substitute) Course
English II	EN 110 Introduction to Writing and Literature (1 unit)
English III	EN 210 Composition/ Literature (1 unit)
English III	½ unit EN 311A and ½ unit from any of the following ½ unit courses: EN 302 Studies in the English Language EN 304 Topics in American and British Lit EN 314 Readings in World Literature EN 322 Studies in Fiction EN 332 Introduction to Film Studies EN 342 Studies in Modern Drama EN 401 Creative Writing EN 402 Expository Writing EN 412 Studies in a Major Author—Shakespeare EN 422 Studies in a Major Author—Faulkner IS 314 Dramatic Text and Performance IS 315 Literature and Science IS 317 Evolution and Literature IS 318 Sacred Literature IS 411 English Renaissance

Core Curriculum Course	Equivalent (Substitute) Course
English IV	½ unit EN 311B or EN 311W and ½ unit from any of the following ½ unit courses: EN 302 Studies in the English Language EN 304 Topics in American and British Lit EN 314 Readings in World Literature EN 322 Studies in Fiction EN 332 Introduction to Film Studies EN 342 Studies in Modern Drama EN 401 Creative Writing EN 402 Expository Writing EN 412 Studies in a Major Author—Shakespeare EN 422 Studies in a Major Author—Faulkner IS 314 Dramatic Text and Performance IS 315 Literature and Science IS 317 Evolution and Literature IS 318 Sacred Literature IS 411 English Renaissance
Advanced Math	Any combination of advanced math courses which equal 1 unit of course credit that are certified by the school to be equivalent of Advanced Math
Algebra I (one unit)	Any combination of advanced math courses which equal 1 unit of course credit that are certified by the school to be equivalent of Algebra I
Algebra II (one unit)	Any combination of advanced math courses which equal 1 unit of course credit that are certified by the school to be equivalent of Algebra II: MA 120 College Algebra (1 unit), or MA 121 Accelerated College Algebra (½ unit) and ½ unit of MA 203 Trigonometry
Biology II	Any combination of ½ unit Biology Lab science courses which equal 1 unit of course credit that are certified by the school to be equivalent of Biology II: BI 210L Cells and Genetics and BI 202L Evolution and Biodiversity (1 unit combined), or 1 unit from the following ½ unit courses: BI 231L Microbiology BI 253L Botany BI 246L Ecology
Chemistry II	Any combination of ½ unit Chemistry lab science courses which equal 1 unit of course credit that are certified by the school to be the equivalent of Chemistry II: CH 201L and CH 202L (1 unit combined) or 1 unit from the following ½ unit courses: CH 313L Analytical Chemistry, CH 314L Polymer Chemistry

Core Curriculum Course	Equivalent (Substitute) Course
Physics I	PH 101L and PH 102L Accelerated Physics I (1 unit combined), or PH 201L and PH 202L Accelerated Physics II (1 unit combined)
Physics II	Any combination of ½ unit Physics lab science courses which equal 1 unit of course credit that are certified by the school to be the equivalent of Physics II, or PH 301L and PH 302L (1 unit combined) or 1 unit from the following ½ unit courses: PH 203L Intro to Astronomy; PH 303L Observational Astronomy and Astrophotography PH 305L Electronics PH 306L Astrophysics
Civics (½ unit) and Free Enterprise (½ unit)	AH 243 American Government and Politics (½ unit) and SS 113 Economics (½ unit)
Western Civilization	EH 121 Ancient and Medieval History (½ unit) and EH 122 Modern History (½ unit)
Advanced Social Studies	Any combination of history courses certified by the school to be the equivalent of one unit of World History, World Geography, Western Civilization, AP European History: 1 unit of credit from the following ½ unit courses: EH 231 History of Tudor-Stuart England EH 232 History of Modern Britain EH 244A European Intellectual History WH 244 Selected Topics in World History

A.5.b. - J.4.b.ii. ...

AUTHORITY NOTE: Promulgated in accordance with R.S. 17:3021-3025, R.S. 17:3042.1 and R.S. 17:3048.1.

HISTORICAL NOTE: Promulgated by the Student Financial Assistance Commission, Office of Student Financial Assistance, LR 22:338 (May 1996), repromulgated LR 24:636 (April 1998), amended LR 24:1902 (October 1998), LR 24:2237 (December 1998), LR 25:257 (February 1999), LR 25:655 (April 1999), LR 25:1794 (October 1999), LR 26:64, 67 (January 2000), LR 26:689 (April 2000), LR 26:1262 (June 2000), LR 26:1602 (August 2000), LR 26:1996, 1999, 2001 (September 2000), LR 26:2268 (October 2000), LR 26:2753 (December 2000), LR 27:36 (January 2001), LR 27:702 (May 2001), LR 27:1219, 1219 (August 2001), repromulgated LR 27:1850 (November 2001), amended LR 28:772 (April 2002), LR 28:2330, 2332 (November 2002), LR 29:125 (February 2003), LR 29:2372 (November 2003), LR 30:1162 (June 2004), LR 30:1471 (July 2004), LR 30:2019 (September 2004), LR 31:37 (January 2005), LR 31:2213 (September 2005), LR 31:3112 (December 2005), LR 32:2239 (December 2006), LR 33:435 (March 2007), LR 33:2357 (November 2007), LR 33:2612 (December 2007), LR 34:1389 (July 2008), LR 35:228 (February 2009), LR 36:312 (February 2010), LR 36:490 (March 2010), LR 36:2269 (October 2010), LR 36:2855 (December 2010), LR 37:2987 (October 2011), LR 38:354 (February 2012), LR 38:

George Badge Eldredge
General Counsel

1210#007

DECLARATION OF EMERGENCY

Department of Health and Hospitals Bureau of Health Services Financing

Abortion Facilities—Licensing Standards
(LAC 48:I.4403, 4409, and 4415)

The Department of Health and Hospitals, Bureau of Health Services Financing amends LAC 48:I.4403, §4409, and §4415 in the Medical Assistance Program as authorized by R.S. 36:254 and R.S. 40:2175.1 et seq., and pursuant to Title XIX of the Social Security Act. This Emergency Rule is promulgated in accordance with the provisions of the Administrative Procedure Act, R.S. 49:953(B)(1) et seq., and shall be in effect for the maximum period allowed under the Act or until adoption of the final Rule, whichever occurs first.

In compliance with the Louisiana Outpatient Abortion Facility Licensing Law, established in Act 391 of the 2001 Regular Session of the Louisiana Legislature, the Department of Health and Hospitals, Office of the Secretary, Bureau of Health Services Financing adopted provisions governing the licensing standards for outpatient abortion facilities (*Louisiana Register*, Volume 29, Number 5). The Department of Health and Hospitals, Bureau of Health Services Financing now proposes to amend the provisions of the May 20, 2003 Rule to clarify provisions governing the licensing of abortion facilities.

This action is being taken to promote the health and welfare of Louisiana citizens by assuring the health and safety of women seeking health care services at licensed abortion facilities. It is estimated that implementation of this Emergency Rule will have no programmatic costs for state fiscal year 2012-2013.

Effective October 20, 2012, the Department of Health and Hospitals, Bureau of Health Services Financing amends the provisions governing the licensing standards for abortion facilities.

Title 48

PUBLIC HEALTH—GENERAL

Part I. General Administration

Subpart 3. Licensing and Certification

Chapter 44. Abortion Facilities

§4403. Licensing Requirements

A. ...

1. An outpatient abortion facility shall be in compliance with all applicable federal, state, and local statutes, laws, rules, regulations, and ordinances, including DHH rules, regulations, and fees, governing or relating to outpatient abortion facilities, abortion or termination procedures, reporting requirements, ultrasound requirements, informed consent requirements or any other matter related to abortion or abortion procedures.

B. - F. ...

AUTHORITY NOTE: Promulgated in accordance with R.S. 40:2175.1 et seq.

HISTORICAL NOTE: Promulgated by the Department of Health and Hospitals, Office of the Secretary, Bureau of Health

Services Financing, LR 29:705 (May 2003), amended by the Department of Health and Hospitals, Bureau of Health Services Financing, LR 39:

§4409. Personnel

A. - A.6. ...

B. Nursing Personnel

1. The outpatient abortion facility shall provide nursing services.

2. The nursing services shall be provided under the direction of a registered nurse.

3. There shall be a plan of administrative authority with delineation of responsibilities and duties for each category of nursing personnel.

4. The number of nursing personnel on duty shall be sufficient to meet the needs of the patient(s) in the facility. An outpatient abortion facility shall have at least one licensed nurse on duty at all times when there is a patient in the facility who is receiving or recovering from an abortion.

5. All nurses employed by the facility shall have a current and valid Louisiana nursing license as a registered nurse (RN) or licensed practical nurse (LPN), as appropriate. The facility shall verify and maintain documentation of the nursing license in the personnel file.

6. All licensed nurses shall have current documentation in their personnel file of successfully completing a basic life support course.

7. Nursing care policies and procedures shall be in writing and be consistent with accepted nursing standards. Policies shall be developed for all nursing service procedures provided at the facility. The procedures shall be reviewed at least annually and revised as necessary.

8. A formalized program of in-service training and evaluation for competency shall be developed for all categories of nursing personnel and for all nursing services provided at the facility. Training related to required job skills shall be provided to nursing personnel. The facility shall maintain documentation of the training provided and evaluation for competency in the personnel file.

C. - D. ...

AUTHORITY NOTE: Promulgated in accordance with R.S. 40:2175.1 et seq.

HISTORICAL NOTE: Promulgated by the Department of Health and Hospitals, Office of the Secretary, Bureau of Health Services Financing, LR 29:707 (May 2003), amended by the Department of Health and Hospitals, Bureau of Health Services Financing, LR 39:

§4415. Patient Records and Reports

A. - A.1. ...

2. The department is entitled to access all books, records, or other documents maintained by or on behalf of the facility on the licensed premises to the extent necessary to ensure compliance with this Chapter 44. Ensuring compliance includes permitting photocopying by the department or providing photocopies to the department of any records or other information by or on behalf of the department as necessary to determine or verify compliance with this Chapter.

A.3 - E.2.c. ...

AUTHORITY NOTE: Promulgated in accordance with R.S. 40:2175.1 et seq.

HISTORICAL NOTE: Promulgated by the Department of Health and Hospitals, Office of the Secretary, Bureau of Health Services Financing, LR 29:708 (May 2003), amended by the Department of Health and Hospitals, Bureau of Health Services Financing, LR 39:

Interested persons may submit written comments to J. Ruth Kennedy, Bureau of Health Services Financing, P.O. Box 91030, Baton Rouge, LA 70821-9030. She is responsible for responding to inquiries regarding this Emergency Rule. A copy of this Emergency Rule is available for review by interested parties at parish Medicaid offices.

Bruce D. Greenstein
Secretary

1210#049

DECLARATION OF EMERGENCY

Department of Health and Hospitals Bureau of Health Services Financing

Adult Dentures Program
Reimbursement Rate Reduction
(LAC 50:XXV.701)

The Department of Health and Hospitals, Bureau of Health Services Financing amends LAC 50:XXV.701 in the Medical Assistance Program as authorized by R.S. 36:254 and pursuant to Title XIX of the Social Security Act and as directed by House Bill 1 of the 2012 Regular Session of the Louisiana Legislature which states: "The secretary is directed to utilize various cost containment measures to ensure expenditures remain at the level appropriated in this Schedule, including but not limited to precertification, preadmission screening, diversion, fraud control, utilization review and management, prior authorization, service limitations, drug therapy management, disease management, cost sharing, and other measures as permitted under federal law." This Emergency Rule is promulgated in accordance with the provisions of the Administrative Procedure Act, R. S. 49:953(B)(1) et seq., and shall be in effect for the maximum period allowed under the Act or until adoption of the final Rule, whichever occurs first.

As a result of a budgetary shortfall in state fiscal year 2010, the Department of Health and Hospitals, Bureau of Health Services Financing amended the provisions governing the Adult Denture Program to extend the time period allowed for denture replacements and relines (*Louisiana Register*, Volume 36, Number 9).

Due to a budgetary shortfall in state fiscal year 2013, the department promulgated an Emergency Rule which amended the provisions governing the reimbursement methodology for adult denture services to reduce the reimbursement rates (*Louisiana Register*, Volume 38, Number 7). This Emergency Rule is being promulgated to continue the provisions of the July 1, 2012 Emergency Rule. This action is being taken to avoid a budget deficit in the medical assistance programs.

Effective October 30, 2012, the Department of Health and Hospitals, Bureau of Health Services Financing amends the

provisions governing the reimbursement methodology for adult denture services to reduce the reimbursement rates.

Title 50

PUBLIC HEALTH—MEDICAL ASSISTANCE

Part XXV. Adult Dentures

Chapter 7. Reimbursement

§701. Fees

A. ...

B. Effective for dates of service on or after July 1, 2012, the reimbursement fees on file for the following adult denture services shall be reduced to the following percentages of the 2009 National Dental Advisory Service Comprehensive Fee Report 70th percentile, unless otherwise stated in this Chapter:

1. 65 percent for the comprehensive evaluation exam; and
2. 56 percent for full mouth x-ray.

C. Removable prosthodontics shall be excluded from the July 1, 2012 reimbursement rate reduction.

AUTHORITY NOTE: Promulgated in accordance with R.S. 36:254 and Title XIX of the Social Security Act.

HISTORICAL NOTE: Promulgated by the Department of Health and Hospitals, Office of the Secretary, Bureau of Health Services Financing, LR 31:81 (January 2005), repromulgated LR 31:1589 (July 2005), amended by the Department of Health and Hospitals, Bureau of Health Services Financing, LR 38:

Implementation of the provisions of this Rule may be contingent upon the approval of the U.S. Department of Health and Human Services, Centers for Medicare and Medicaid Services (CMS), if it is determined that submission to CMS for review and approval is required.

Interested persons may submit written comments to J. Ruth Kennedy, Bureau of Health Services Financing, P.O. Box 91030, Baton Rouge, LA 70821-9030. She is responsible for responding to inquiries regarding this Emergency Rule. A copy of this Emergency Rule is available for review by interested parties at parish Medicaid offices.

Bruce D. Greenstein
Secretary

1210#061

DECLARATION OF EMERGENCY

**Department of Health and Hospitals
Bureau of Health Services Financing
and
Office of Aging and Adult Services**

All Inclusive Care for the Elderly
Reimbursement Rate Reduction
(LAC 50:XXIII.1301)

The Department of Health and Hospitals, Bureau of Health Services Financing and the Office of Aging and Adult Services amend LAC 50:XXIII.1301 in the Medical Assistance Program as authorized by R.S. 36:254 and pursuant to Title XIX of the Social Security Act and as directed by House Bill 1 of the 2012 Regular Session of the Louisiana Legislature which states: "The secretary is directed to utilize various cost containment measures to ensure expenditures remain at the level appropriated in this

Schedule, including but not limited to precertification, preadmission screening, diversion, fraud control, utilization review and management, prior authorization, service limitations, drug therapy management, disease management, cost sharing, and other measures as permitted under federal law." This Emergency Rule is promulgated in accordance with the provisions of the Administrative Procedure Act, R.S. 49:953(B)(1) et seq., and shall be in effect for the maximum period allowed under the Act or until adoption of the final Rule, whichever occurs first.

As a result of a budgetary shortfall in state fiscal year 2011, the Department of Health and Hospitals, Bureau of Health Services Financing and the Office of Aging and Adult Services amended the provisions governing the reimbursement methodology for the Program of All Inclusive Care for the Elderly (PACE) to reduce the capitated amount paid to PACE organizations (*Louisiana Register*, Volume 37, Number 6).

Due to a budgetary shortfall in state fiscal year 2013, the Department of Health and Hospitals, Bureau of Health Services Financing and the Office of Aging and Adult Services promulgated an Emergency Rule which amended the provisions governing the reimbursement methodology for PACE to reduce the capitated amount paid to PACE organizations (*Louisiana Register*, Volume 38, Number 7). This Emergency Rule is being promulgated to continue the provisions of the July 1, 2012 Emergency Rule. This action is being taken to avoid a budget deficit in the medical assistance programs.

Effective October 30, 2012, the Department of Health and Hospitals, Bureau of Health Services Financing and the Office of Aging and Adult Services amend the provisions governing the reimbursement methodology for the Program of All Inclusive Care for the Elderly to reduce the capitated amount paid to PACE organizations.

Title 50

PUBLIC HEALTH—MEDICAL ASSISTANCE

Part XXIII. All Inclusive Care for the Elderly

Chapter 13. Reimbursement

§1301. Payment

A. - L. ...

M. Effective for dates of service on or after July 1, 2012, the monthly capitated amount paid to a PACE organization shall be reduced by 2 percent of the capitated amount on file as of June 30, 2012.

AUTHORITY NOTE: Promulgated in accordance with R.S. 36:254 and Title XIX of the Social Security Act.

HISTORICAL NOTE: Promulgated by the Department of Health and Hospitals, Office of the Secretary, Bureau of Health Services Financing, LR 30:250 (February 2004), amended LR 33:850 (May 2007), amended by the Department of Health and Hospitals, Bureau of Health Services Financing and the Office of Aging and Adult Services, LR 37:1572 (June 2011), LR 38:

Implementation of the provisions of this Rule may be contingent upon the approval of the U.S. Department of Health and Human Services, Centers for Medicare and Medicaid Services (CMS), if it is determined that submission to CMS for review and approval is required.

Interested persons may submit written comments to J. Ruth Kennedy, Bureau of Health Services Financing, P.O. Box 91030, Baton Rouge, LA 70821-9030. She is

responsible for responding to inquiries regarding this Emergency Rule. A copy of this Emergency Rule is available for review by interested parties at parish Medicaid offices.

Bruce D. Greenstein
Secretary

1210#062

DECLARATION OF EMERGENCY

Department of Health and Hospitals Bureau of Health Services Financing

Ambulatory Surgical Centers
Reimbursement Rate Reduction
(LAC 50:XI.7503)

The Department of Health and Hospitals, Bureau of Health Services Financing amends LAC 50:XI.7503 in the Medical Assistance Program as authorized by R.S. 36:254 and pursuant to Title XIX of the Social Security Act and as directed by House Bill 1 of the 2012 Regular Session of the Louisiana Legislature which states: "The secretary is directed to utilize various cost containment measures to ensure expenditures remain at the level appropriated in this Schedule, including but not limited to precertification, preadmission screening, diversion, fraud control, utilization review and management, prior authorization, service limitations, drug therapy management, disease management, cost sharing, and other measures as permitted under federal law." This Emergency Rule is promulgated in accordance with the provisions of the Administrative Procedure Act, R.S. 49:953(B)(1) et seq., and shall be in effect for the maximum period allowed under the Act or until adoption of the final Rule, whichever occurs first.

As a result of a budgetary shortfall in state fiscal year 2011, the Department of Health and Hospitals, Bureau of Health Services Financing amended the provisions governing the reimbursement methodology for ambulatory surgical centers to further reduce the reimbursement rates paid for ambulatory surgical services (*Louisiana Register*, Volume 37, Number 6).

As a result of a budgetary shortfall in state fiscal year 2013, the Department of Health and Hospitals, Bureau of Health Services Financing promulgated an Emergency Rule which amended the provisions governing the reimbursement methodology for ambulatory surgical centers to reduce the reimbursement rates (*Louisiana Register*, Volume 38, Number 7). This Emergency Rule is being promulgated to continue the provisions of the July 1, 2012 Emergency Rule. This action is being taken to avoid a budget deficit in the medical assistance programs.

Effective October 30, 2012, the Department of Health and Hospitals, Bureau of Health Services Financing amends the provisions governing the reimbursement methodology for ambulatory surgical centers to reduce the reimbursement rates.

Title 50

PUBLIC HEALTH—MEDICAL ASSISTANCE

Part XI. Clinic Services

Subpart 11. Ambulatory Surgical Centers

Chapter 75. Reimbursement

§7503. Reimbursement Methodology

A. - F. ...

G. Effective for dates of service on or after July 1, 2012, the reimbursement for surgical services provided by an ambulatory surgical center shall be reduced by 3.7 percent of the fee amounts on file as of June 30, 2012.

AUTHORITY NOTE: Promulgated in accordance with R.S. 36:254 and Title XIX of the Social Security Act.

HISTORICAL NOTE: Promulgated by the Department of Health and Hospitals, Bureau of Health Services Financing, LR 35:1889 (September 2009), amended LR 36:2278 (October 2010), LR 37:1572 (June 2011), LR 38:

Implementation of the provisions of this Rule may be contingent upon the approval of the U.S. Department of Health and Human Services, Centers for Medicare and Medicaid Services (CMS), if it is determined that submission to CMS for review and approval is required.

Interested persons may submit written comments to J. Ruth Kennedy, Bureau of Health Services Financing, P.O. Box 91030, Baton Rouge, LA 70821-9030. She is responsible for responding to inquiries regarding this Emergency Rule. A copy of this Emergency Rule is available for review by interested parties at parish Medicaid offices.

Bruce D. Greenstein
Secretary

1210#063

DECLARATION OF EMERGENCY

Department of Health and Hospitals Bureau of Health Services Financing and Office of Behavioral Health

Behavioral Health Services
Statewide Management Organization
Adults Capitated Payment Reduction
(LAC 50:XXXIII.501)

The Department of Health and Hospitals, Bureau of Health Services Financing and the Office for Behavioral Health amend LAC 50:XXXIII.501 in the Medical Assistance Program as authorized by R.S. 36:254 and pursuant to Title XIX of the Social Security Act and as directed by House Bill 1 of the 2012 Regular Session of the Louisiana Legislature which states: "The secretary is directed to utilize various cost containment measures to ensure expenditures remain at the level appropriated in this Schedule, including but not limited to precertification, preadmission screening, diversion, fraud control, utilization review and management, prior authorization, service limitations, drug therapy management, disease management,

cost sharing, and other measures as permitted under federal law.” This Emergency Rule is promulgated in accordance with the provisions of the Administrative Procedure Act, R.S. 49:953(B)(1) et seq., and shall be in effect for the maximum period allowed under the Act or until adoption of the final Rule, whichever occurs first.

The Department of Health and Hospitals, Bureau of Health Services Financing adopted provisions to implement a coordinated behavioral health services system under the Louisiana Medicaid Program to provide services through the utilization of a statewide management organization that is responsible for the necessary administrative and operational functions to ensure adequate coordination and delivery of behavioral health services (*Louisiana Register*, Volume 38, Number 2).

As a result of a budgetary shortfall in state fiscal year 2013, the department promulgated an Emergency Rule which amended the provisions governing the reimbursement of adult behavioral health services coordinated through the Statewide Management Organization to reduce the capitated payment amount (*Louisiana Register*, Volume 38, Number 7). This Emergency Rule is being promulgated to continue the provisions of the July 1, 2012 Emergency Rule. This action is being taken to avoid a budget deficit in the medical assistance programs.

Effective October 30, 2012, the Department of Health and Hospitals, Bureau of Health Services Financing and the Office of Behavioral Health amend the provisions governing the reimbursement of adult behavioral health services coordinated by the Statewide Management Organization to reduce the capitated payment amounts.

Title 50

PUBLIC HEALTH—MEDICAL ASSISTANCE

Part XXXIII. Behavioral Health Services

Subpart 1. Statewide Management Organization

Chapter 5. Reimbursement

§501. Reimbursement Methodology

A. - B. ...

C. Effective for dates of service on or after July 1, 2012, the monthly capitation payments to the PIHP/SMO for adult behavioral health services shall be reduced by 1.927 percent of the monthly capitation payments on file as of June 30, 2012.

AUTHORITY NOTE: Promulgated in accordance with R.S. 36:254 and Title XIX of the Social Security Act.

HISTORICAL NOTE: Promulgated by the Department of Health and Hospitals, Bureau of Health Services Financing, LR 38:363 (February 2012), amended by the Department of Health and Hospitals, Bureau of Health Services Financing and the Office of Behavioral Health, LR 38:

Implementation of the provisions of this Rule may be contingent upon the approval of the U.S. Department of Health and Human Services, Centers for Medicare and Medicaid Services (CMS), if it is determined that submission to CMS for review and approval is required.

Interested persons may submit written comments to J. Ruth Kennedy, Bureau of Health Services Financing, P.O. Box 91030, Baton Rouge, LA 70821-9030. She is responsible for responding to inquiries regarding this

Emergency Rule. A copy of this Emergency Rule is available for review by interested parties at parish Medicaid offices.

Bruce D. Greenstein
Secretary

1210#064

DECLARATION OF EMERGENCY

Department of Health and Hospitals Bureau of Health Services Financing and Office of Behavioral Health

Children’s Behavioral Health Services
Reimbursement Rate Reduction
(LAC 50:XXXIII.2701)

The Department of Health and Hospitals, Bureau of Health Services Financing and the Office of Behavioral Health amend LAC 50:XXXIII.2701 in the Medical Assistance Program as authorized by R.S. 36:254 and pursuant to Title XIX of the Social Security Act and as directed by House Bill 1 of the 2012 Regular Session of the Louisiana Legislature which states: “The secretary is directed to utilize various cost containment measures to ensure expenditures remain at the level appropriated in this Schedule, including but not limited to precertification, preadmission screening, diversion, fraud control, utilization review and management, prior authorization, service limitations, drug therapy management, disease management, cost sharing, and other measures as permitted under federal law.” This Emergency Rule is promulgated in accordance with the provisions of the Administrative Procedure Act, R.S. 49:953(B)(1) et seq., and shall be in effect for the maximum period allowed under the Act or until adoption of the final Rule, whichever occurs first.

The Department of Health and Hospitals, Bureau of Health Services Financing adopted provisions to implement a coordinated services system through the Louisiana Behavioral Health Partnership to provide behavioral health services to children under the age of 21 (*Louisiana Register*, Volume 38, Number 2).

Due to a budgetary shortfall in state fiscal year 2013, the Department of Health and Hospitals, Bureau of Health Services Financing and the Office of Behavioral Health promulgated an Emergency Rule which amended the provisions governing the reimbursement methodology for children’s behavioral health services to reduce the reimbursement rates (*Louisiana Register*, Volume 38, Number 7). This Emergency Rule is being promulgated to continue the provisions of the July 1, 2012 Emergency Rule. This action is being taken to avoid a budget deficit in the medical assistance programs.

Effective October 30, 2012, the Department of Health and Hospitals, Bureau of Health Services Financing and the Office of Behavioral Health amend the provisions governing the reimbursement methodology for children’s behavioral health services to reduce the reimbursement rates.

Title 50
PUBLIC HEALTH—MEDICAL ASSISTANCE
Part XXXIII. Behavioral Health Services
Subpart 3. Children’s Behavioral Health Services
Chapter 27. Reimbursement
§2701. Reimbursement Methodology

A. ...

B. Effective for dates of service on or after July 1, 2012, the reimbursement rates for the following behavioral health services provided to children/adolescents shall be reduced by 1.44 percent of the rates in effect on June 30, 2012:

1. therapeutic services;
2. rehabilitation services; and
3. crisis intervention services.

AUTHORITY NOTE: Promulgated in accordance with R.S. 36:254 and Title XIX of the Social Security Act.

HISTORICAL NOTE: Promulgated by the Department of Health and Hospitals, Bureau of Health Services Financing, LR 38:365 (February 2012), amended LR 38:

Implementation of the provisions of this Rule may be contingent upon the approval of the U.S. Department of Health and Human Services, Centers for Medicare and Medicaid Services (CMS), if it is determined that submission to CMS for review and approval is required.

Interested persons may submit written comments to J. Ruth Kennedy, Bureau of Health Services Financing, P.O. Box 91030, Baton Rouge, LA 70821-9030. She is responsible for responding to inquiries regarding this Emergency Rule. A copy of this Emergency Rule is available for review by interested parties at parish Medicaid offices.

Bruce D. Greenstein
Secretary

1210#065

DECLARATION OF EMERGENCY

Department of Health and Hospitals
Bureau of Health Services Financing

Early and Periodic Screening, Diagnosis and Treatment
Dental Program—Reimbursement Rate Reduction
(LAC 50:XV.6905)

The Department of Health and Hospitals, Bureau of Health Services Financing amends LAC 50: XV.6903 in the Medical Assistance Program as authorized by R.S. 36:254 and pursuant to Title XIX of the Social Security Act and as directed by House Bill 1 of the 2012 Regular Session of the Louisiana Legislature which states: “The secretary is directed to utilize various cost containment measures to ensure expenditures remain at the level appropriated in this Schedule, including but not limited to precertification, preadmission screening, diversion, fraud control, utilization review and management, prior authorization, service limitations, drug therapy management, disease management, cost sharing, and other measures as permitted under federal law.” This Emergency Rule is promulgated in accordance with the provisions of the Administrative Procedure Act, R.S. 49:953(B)(1) et seq., and shall be in effect for the maximum period allowed under the Act or until adoption of the final Rule, whichever occurs first.

Due to a continuing budgetary shortfall in state fiscal year 2011, the Department of Health and Hospitals, Bureau of Health Services Financing amended the provisions governing the reimbursement methodology for dental services in the Early and Periodic Screening, Diagnosis, and Treatment (EPSDT) Program to further reduce the reimbursement rates (*Louisiana Register*, Volume 37, Number 6).

As a result of a budgetary shortfall in state fiscal year 2013, the Department of Health and Hospitals, Bureau of Health Services Financing promulgated an Emergency Rule which amended the provisions governing the reimbursement methodology for EPSDT dental services to reduce the reimbursement rates (*Louisiana Register*, Volume 38, Number 7). This Emergency Rule is being promulgated to continue the provisions of the July 1, 2012 Emergency Rule. This action is being taken to avoid a budget deficit in the medical assistance programs.

Effective October 30, 2012, the Department of Health and Hospitals, Bureau of Health Services Financing amends the provisions governing the reimbursement methodology for EPSDT dental services to reduce the reimbursement rates.

Title 50
PUBLIC HEALTH—MEDICAL ASSISTANCE
Part XV. Services for Special Populations
Subpart 5. Early and Periodic Screening,
Diagnosis and Treatment

Chapter 69. Dental Services

§6905. Reimbursement

A. - H. ...

I. Effective for dates of service on or after July 1, 2012, the reimbursement fees for EPSDT dental services shall be reduced to the following percentages of the 2009 National Dental Advisory Service Comprehensive Fee Report 70th percentile, unless otherwise stated in this Chapter:

1. 65 percent for the following oral evaluation services:
 - a. periodic oral examination;
 - b. oral examination-patients under three years of age; and
 - c. comprehensive oral examination-new patients;
 2. 62 percent for the following annual and periodic diagnostic and preventive services:
 - a. radiographs-periapical, first film;
 - b. radiographs-periapical, each additional film;
 - c. radiographs-panoramic film;
 - d. diagnostic casts;
 - e. prophylaxis-adult and child;
 - f. topical application of fluoride, adult and child (prophylaxis not included); and
 - g. topical fluoride varnish, therapeutic application for moderate to high caries risk patients (under 6 years of age);
 3. 45 percent for the following diagnostic and adjunctive general services:
 - a. oral/facial image;
 - b. non-intravenous conscious sedation; and
 - c. hospital call; and
 4. 56 percent for the remainder of the dental services.
- J. Removable prosthodontics and orthodontic services are excluded from the July 1, 2012 rate reduction.

AUTHORITY NOTE: Promulgated in accordance with R.S. 36:254 and Title XIX of the Social Security Act.

HISTORICAL NOTE: Promulgated by the Department of Health and Hospitals, Office of the Secretary, Bureau of Health Services Financing, LR 33:1138 (June 2007), amended LR 34:1032 (June 2008), amended by the Department of Health and Hospitals, Bureau of Health Services Financing, LR 35:1890 (September 2009), amended LR 36:2040 (September 2010), LR 37:1598 (June 2011), LR 38:

Implementation of the provisions of this Rule may be contingent upon the approval of the U.S. Department of Health and Human Services, Centers for Medicare and Medicaid Services (CMS), if it is determined that submission to CMS for review and approval is required.

Interested persons may submit written comments to J. Ruth Kennedy, Bureau of Health Services Financing, P.O. Box 91030, Baton Rouge, LA 70821-9030. She is responsible for responding to inquiries regarding this Emergency Rule. A copy of this Emergency Rule is available for review by interested parties at parish Medicaid offices.

Bruce D. Greenstein
Secretary

1210#066

DECLARATION OF EMERGENCY

Department of Health and Hospitals Bureau of Health Services Financing

Early and Periodic Screening, Diagnosis and Treatment
School-Based Nursing Services
(LAC 50:XV.Chapter 95)

The Department of Health and Hospitals, Bureau of Health Services Financing amends LAC 50:XV.Chapter 95 in the Medical Assistance Program as authorized by R.S. 36:254 and pursuant to Title XIX of the Social Security Act. This Emergency Rule is promulgated in accordance with the provisions of the Administrative Procedure Act, R.S. 49:953(B)(1) et seq., and shall be in effect for the maximum period allowed under the Act or until adoption of the final Rule, whichever occurs first.

The Department of Health and Hospitals, Bureau of Health Services Financing provides Medicaid coverage for health care services rendered to children and youth under the age of 21 through the Early and Periodic Screening, Diagnosis and Treatment (EPSDT) Program. The department promulgated an Emergency Rule which amended the provisions governing the EPSDT Program in order to adopt provisions to establish reimbursement and coverage for school-based nursing services rendered to all children enrolled in Louisiana schools (*Louisiana Register*, Volume 37, Number 12). The department promulgated an Emergency Rule which amended the January 1, 2012 Emergency Rule to clarify the provisions governing EPSDT school-based nursing services (*Louisiana Register*, Volume 38, Number 3). This Emergency Rule is being promulgated to continue the provisions of the March 20, 2012 Emergency Rule. This action is being taken to promote the health and welfare of Medicaid eligible recipients and to assure a more efficient and effective delivery of health care services.

Effective November 16, 2012, the Department of Health and Hospitals, Bureau of Health Services Financing adopts

provisions to provide Medicaid coverage of school-based nursing services covered under the Early and Periodic Screening, Diagnosis, and Treatment Program.

Title 50

PUBLIC HEALTH—MEDICAL ASSISTANCE

Part XV. Services for Special Populations

Subpart 5. Early and Periodic Screening, Diagnosis, and Treatment

Chapter 95. School-Based Nursing Services

§9501. General Provisions

A. EPSDT school-based nursing services are provided by a registered nurse (RN) within a local education agency (LEA). The goal of these services is to prevent or mitigate disease, enhance care coordination, and reduce costs by preventing the need for tertiary care. Providing these services in the school increases access to health care for children and youth resulting in a more efficient and effective delivery of care.

B. RNs providing school-based nursing services are required to maintain an active RN license with the state of Louisiana and comply with the Louisiana Nurse Practice Act.

C. School-based nursing services shall be covered for all recipients in the school system and not limited to those with an Individualized Education Program (IEP).

D. School boards and staff shall collaborate for all services with the Medicaid recipient's BAYOU HEALTH plan and shall ensure compliance with established protocols. In a fee-for-service situation, for the non-BAYOU HEALTH individuals, staff will make necessary referrals.

AUTHORITY NOTE: Promulgated in accordance with R.S. 36:254 and Title XIX of the Social Security Act.

HISTORICAL NOTE: Promulgated by the Department of Health and Hospitals, Bureau of Health Services Financing, LR 38:

§9503. Covered Services

A. The following school-based nursing services shall be covered:

1. Episodic Care. This is unplanned care that occurs when children see the nurse for assessment of a health concern. Episodic care includes but is not limited to:

- a. nose bleeds;
- b. cuts;
- c. bruises; or
- d. flu symptoms.

2. Chronic Medical Condition Management and Care Coordination. This is care based on one of the following criteria:

a. The child has a chronic medical condition or disability requiring implementation of a health plan/protocol (examples would be children with asthma, diabetes, or cerebral palsy). There must be a written health care plan based on a health assessment performed by the RN. The date of the completion of the plan and the name of the person completing the plan must be included in the written plan. Each health care service required and the schedule for its provision must be described in the plan.

b. Medication Administration. This service is scheduled as part of a health care plan developed by either the treating physician or the school district LEA. Administration of medication will be at the direction of the physician and within the license of the RN and must be approved within the district LEA policies.

c. Implementation of Physician's Orders. These services shall be provided as a result of receipt of a written plan of care from the child's physician/BAYOU HEALTH provider or an IEP/Health care plan for students with disabilities.

3. Immunization Assessments. These services are nursing assessments of health status (immunizations) required by the Office of Public Health. This service requires an RN to assess the vaccination status of children in these cohorts once each year. This assessment is limited to the following children:

- a. children enrolling in a school for the first time;
- b. pre-Kindergarten children;
- c. Kindergarten children; and
- d. children entering sixth grade; or
- e. any student 11 years of age regardless of grade.

4. EPSDT Program Periodicity Schedule for Screenings. A nurse employed by a school district may perform any of these screens within their licensure for BAYOU HEALTH members as authorized by the BAYOU HEALTH plan or as compliant with fee-for-service for non-BAYOU HEALTH individuals. The results of these screens must be made available to the BAYOU HEALTH provider as part of the care coordination plan of the district. The screens shall be performed according to the periodicity schedule including any inter-periodic screens.

- a. Repealed.

AUTHORITY NOTE: Promulgated in accordance with R.S. 36:254 and Title XIX of the Social Security Act.

HISTORICAL NOTE: Promulgated by the Department of Health and Hospitals, Bureau of Health Services Financing, LR 38:

§9505. Reimbursement Methodology

A. Payment for EPSDT school-based nursing services shall be based on the most recent school year's actual cost as determined by desk review and/or audit for each LEA provider.

1. Each LEA shall determine cost annually by using DHH's Cost Report for Nursing Service Cost form based on the Direct Services Cost Report.

2. Direct cost shall be limited to the amount of total compensation (salaries, vendor payments and fringe benefits) of current nursing service providers as allocated to nursing services for Medicaid special education recipients. The direct cost related to the electronic health record shall be added to the compensation costs to arrive at the total direct costs for nursing services. There are no additional direct costs included in the rate.

3. Indirect cost shall be derived by multiplying the cognizant agency indirect cost unrestricted rate assigned by the Department of Education to each LEA. There are no additional indirect costs included.

4. To determine the amount of nursing services cost that may be attributed to Medicaid; the ratio of total Medicaid students in the LEA to all students in the LEA is multiplied by total direct cost. Cost data is subject to certification by each LEA. This serves as the basis for obtaining Federal Medicaid funding.

B. For the nursing services, the participating LEAs' actual cost of providing the services shall be claimed for Medicaid Federal Financial Participation (FFP) based on the following methodology.

1. The state shall gather actual expenditure information for each LEA through its Payroll/Benefits and Accounts Payable System.

2. Develop Direct Cost - The Payroll Cost Base. Total annual salaries and benefits paid, as well as contracted (vendor) payments, shall be obtained initially from each LEA's Payroll/Benefits and Accounts Payable system. This data shall be reported on DHH's Nursing Services Cost Report form for all nursing service personnel (i.e. all personnel providing LEA nursing treatment services covered under the state plan).

3. Adjust the Payroll Cost Base. The payroll cost base shall be reduced for amounts reimbursed by other funding sources (e.g. Federal grants). The payroll cost base shall not include any amounts for staff whose compensation is 100 percent reimbursed by a funding source other than state/local funds. This application results in total adjusted salary cost.

4. Determine the Percentage of Time to Provide All Nursing Services. A time study which incorporates the CMS-approved Medicaid Administrative Claiming (MAC) methodology for nursing service personnel shall be used to determine the percentage of time nursing service personnel spend on nursing services and General and Administrative (G and A) time. This time study will assure that there is no duplicate claiming. The G and A percentage shall be reallocated in a manner consistent with the CMS approved Medicaid Administrative Claiming methodology. Total G and A time shall be allocated to all other activity codes based on the percentage of time spent on each respective activity. To reallocate G and A time to nursing services, the percentage of time spent on nursing services shall be divided by 100 percent minus the percentage of G and A time. This shall result in a percentage that represents the nursing services with appropriate allocation of G and A. This percentage shall be multiplied by total adjusted salary cost as determined B.4 above to allocate cost to school based services. The product represents total direct cost.

a. A sufficient number of nursing service personnel shall be sampled to ensure results that will have a confidence level of at least 95 percent with a precision of plus or minus five percent overall.

5. Determine Indirect Cost. Indirect cost shall be determined by multiplying each LEA's indirect unrestricted rate assigned by the cognizant agency (the Department of Education) by total adjusted direct cost as determined under B.3 above. No additional indirect cost shall be recognized outside of the cognizant agency indirect rate. The sum of direct cost and indirect cost shall be the total direct service cost for all students receiving nursing services.

6. Allocate Direct Service Cost to Medicaid. To determine the amount of cost that may be attributed to Medicaid, total cost as determined under B.5 above shall be multiplied by the ratio of Medicaid students in the LEA to all students in the LEA. This results in total cost that may be certified as Medicaid's portion of school-based nursing services cost.

C. Reconciliation of LEA Certified Costs and Medicaid Management Information System (MMIS) Paid Claims. Each LEA shall complete the Nursing Services Cost Report and submit the cost report(s) no later than five months after

the fiscal year period ends (June 30), and reconciliation shall be completed within 12 months from the fiscal year end. All filed nursing services cost reports shall be subject to desk review by the department's audit contractor. The department shall reconcile the total expenditures (both state and federal share) for each LEA's nursing services. The Medicaid certified cost expenditures from the nursing services cost report(s) will be reconciled against the MMIS paid claims data and the department shall issue a notice of final settlement pending audit that denotes the amount due to or from the LEA. This reconciliation is inclusive of all nursing services provided by the LEA.

D. Cost Settlement Process. As part of its financial oversight responsibilities, the department shall develop audit and review procedures to audit and process final settlements for certain LEAs. The audit plan shall include a risk assessment of the LEAs using available paid claims data to determine the appropriate level of oversight.

1. The financial oversight of all LEAs shall include reviewing the costs reported on the Nursing Services Cost Reports against the allowable costs, performing desk reviews and conducting limited reviews.

2. The department will make every effort to audit each LEA at least every four years. These activities shall be performed to ensure that audit and final settlement occurs no later than two years from the LEA's fiscal year end for the cost reporting period audited. LEAs may appeal audit findings in accordance with DHH appeal procedures.

3. The department shall adjust the affected LEA's payments no less than annually, when any reconciliation or final settlement results in significant underpayments or overpayments to any LEA. By performing the reconciliation and final settlement process, there shall be no instances where total Medicaid payments for services exceed 100 percent of actual, certified expenditures for providing LEA services for each LEA.

4. If the interim payments exceed the actual, certified costs of an LEA's Medicaid services, the department shall recoup the overpayment in one of the following methods:

- a. offset all future claim payments from the affected LEA until the amount of the overpayment is recovered;
- b. recoup an agreed upon percentage from future claims payments to the LEA to ensure recovery of the overpayment within one year; or
- c. recoup an agreed upon dollar amount from future claims payments to the LEA to ensure recovery of the overpayment within one year.

5. If the actual certified costs of an LEA's Medicaid services exceed interim Medicaid payments, the department will pay this difference to the LEA in accordance with the final actual certification agreement.

AUTHORITY NOTE: Promulgated in accordance with R.S. 36:254 and Title XIX of the Social Security Act.

HISTORICAL NOTE: Promulgated by the Department of Health and Hospitals, Bureau of Health Services Financing, LR 38:

Implementation of the provisions of this Rule may be contingent upon the approval of the U.S. Department of Health and Human Services, Centers for Medicare and Medicaid Services (CMS), if it is determined that submission to CMS for review and approval is required.

Interested persons may submit written comments to J. Ruth Kennedy, Bureau of Health Services Financing, P.O. Box 91030, Baton Rouge, LA 70821-9030. She is

responsible for responding to inquiries regarding this Emergency Rule. A copy of this Emergency Rule is available for review by interested parties at parish Medicaid offices.

Bruce D. Greenstein
Secretary

1210#067

DECLARATION OF EMERGENCY

Department of Health and Hospitals Bureau of Health Services Financing

End Stage Renal Disease Facilities
Reimbursement Rate Reduction
(LAC 50:XI.6901 and 6903)

The Department of Health and Hospitals, Bureau of Health Services Financing amends LAC 50:XI.6901 and §6903 in the Medical Assistance Program as authorized by R.S. 36:254 and pursuant to Title XIX of the Social Security Act and as directed by House Bill 1 of the 2012 Regular Session of the Louisiana Legislature which states: "The secretary is directed to utilize various cost containment measures to ensure expenditures remain at the level appropriated in this Schedule, including but not limited to precertification, preadmission screening, diversion, fraud control, utilization review and management, prior authorization, service limitations, drug therapy management, disease management, cost sharing, and other measures as permitted under federal law." This Emergency Rule is promulgated in accordance with the provisions of the Administrative Procedure Act, R.S. 49:953(B)(1) et seq., and shall be in effect for the maximum period allowed under the Act or until adoption of the final Rule, whichever occurs first.

As a result of a budgetary shortfall in state fiscal year 2011, the Department of Health and Hospitals, Bureau of Health Services Financing amended the provisions governing the reimbursement methodology for end stage renal disease (ESRD) facilities to reduce the reimbursement rates (*Louisiana Register*, Volume 37, Number 6).

Due to a budgetary shortfall in state fiscal year 2013, the department promulgated an Emergency Rule which amended the provisions governing the reimbursement methodology for ESRD facilities to reduce the reimbursement rates (*Louisiana Register*, Volume 38, Number 7). This Emergency Rule is being promulgated to continue the provisions of the July 1, 2012 Emergency Rule. This action is being taken to avoid a budget deficit in the medical assistance programs.

Effective October 30, 2012, the Department of Health and Hospitals, Bureau of Health Services Financing amends the provisions governing the reimbursement methodology for end stage renal disease facilities to reduce the reimbursement rates.

Title 50

PUBLIC HEALTH—MEDICAL ASSISTANCE

Part XI. Clinic Services

Subpart 9. End Stage Renal Disease Facilities

Chapter 69. Reimbursement

§6901. General Provisions

A. - F. ...

G. Effective for dates of service on or after July 1, 2012, the reimbursement to ESRD facilities shall be reduced by 3.7 percent of the rates in effect on June 30, 2012.

AUTHORITY NOTE: Promulgated in accordance with R.S. 36:254 and Title XIX of the Social Security Act.

HISTORICAL NOTE: Promulgated by the Department of Health and Hospitals, Office of the Secretary, Bureau of Health Services Financing, LR 30:1022 (May 2004), amended by the Department of Health and Hospitals, Bureau of Health Services Financing, LR 35:1891 (September 2009), LR 36:2040 (September 2010), LR 37:1599 (June 2011), LR 38:

§6903. Medicare Part B Claims

A. - F. ...

G. Effective for dates of service on or after July 1, 2012, the reimbursement to ESRD facilities for Medicare Part B claims shall be reduced by 3.7 percent of the rates in effect on June 30, 2012.

AUTHORITY NOTE: Promulgated in accordance with R.S. 36:254 and Title XIX of the Social Security Act.

HISTORICAL NOTE: Promulgated by the Department of Health and Hospitals, Bureau of Health Services Financing, LR 35:1891 (September 2009), amended LR 36:2040 (September 2010), LR 37:1599 (June 2011), LR 38:

Implementation of the provisions of this Rule may be contingent upon the approval of the U.S. Department of Health and Human Services, Centers for Medicare and Medicaid Services (CMS), if it is determined that submission to CMS for review and approval is required.

Interested persons may submit written comments to J. Ruth Kennedy, Bureau of Health Services Financing, P.O. Box 91030, Baton Rouge, LA 70821-9030. She is responsible for responding to inquiries regarding this Emergency Rule. A copy of this Emergency Rule is available for review by interested parties at parish Medicaid offices.

Bruce D. Greenstein
Secretary

1210#068

DECLARATION OF EMERGENCY

Department of Health and Hospitals Bureau of Health Services Financing

Family Planning Clinics—Reimbursement Rate Reduction (LAC 50:XI.3501)

The Department of Health and Hospitals, Bureau of Health Services Financing amends LAC 50:XI.3501 in the Medical Assistance Program as authorized by R.S. 36:254 and pursuant to Title XIX of the Social Security Act and as directed by House Bill 1 of the 2012 Regular Session of the Louisiana Legislature which states: “The secretary is directed to utilize various cost containment measures to ensure expenditures remain at the level appropriated in this Schedule, including but not limited to precertification, preadmission screening, diversion, fraud control, utilization review and management, prior authorization, service limitations, drug therapy management, disease management, cost sharing, and other measures as permitted under federal law.” This Emergency Rule is promulgated in accordance

with the provisions of the Administrative Procedure Act, R.S. 49:953(B)(1) et seq., and shall be in effect for the maximum period allowed under the Act or until adoption of the final Rule, whichever occurs first.

As a result of a budgetary shortfall in state fiscal year 2011, the Department of Health and Hospitals, Bureau of Health Services Financing amended the provisions governing the reimbursement methodology for family planning clinics to reduce the reimbursement rates (*Louisiana Register*, Volume 37, Number 6). As a result of a budgetary shortfall in state fiscal year 2013, the Department of Health and Hospitals, Bureau of Health Services Financing promulgated an Emergency Rule which amended the provisions governing the reimbursement methodology for family planning clinics to reduce the reimbursement rates (*Louisiana Register*, Volume 38, Number 7). This Emergency Rule is being promulgated to continue the provisions of the July 1, 2012 Emergency Rule. This action is being taken to avoid a budget deficit in the medical assistance programs.

Effective October 30, 2012, the Department of Health and Hospitals, Bureau of Health Services Financing amends the provisions governing the reimbursement methodology for family planning clinics to reduce the reimbursement rates.

Title 50

PUBLIC HEALTH—MEDICAL ASSISTANCE

Part XI. Clinic Services

Subpart 5. Family Planning

Chapter 35. Reimbursement

§3501. Reimbursement Methodology

A. - B. ...

C. Effective for dates of service on or after July 1, 2012, the reimbursement rates for family planning clinics shall be equal to the reimbursement rates for family planning services in the Professional Services Program.

AUTHORITY NOTE: Promulgated in accordance with R.S. 36:254 and Title XIX of the Social Security Act.

HISTORICAL NOTE: Promulgated by the Department of Health and Hospitals, Office of the Secretary, Bureau of Health Services Financing, LR 30:1022 (May 2004), amended by the Department of Health and Hospitals, Bureau of Health Services Financing, LR 37:1600 (June 2011), LR 38:

Implementation of the provisions of this Rule may be contingent upon the approval of the U.S. Department of Health and Human Services, Centers for Medicare and Medicaid Services (CMS), if it is determined that submission to CMS for review and approval is required.

Interested persons may submit written comments to J. Ruth Kennedy, Bureau of Health Services Financing, P.O. Box 91030, Baton Rouge, LA 70821-9030. She is responsible for responding to inquiries regarding this Emergency Rule. A copy of this Emergency Rule is available for review by interested parties at parish Medicaid offices.

Bruce D. Greenstein
Secretary

1210#069

DECLARATION OF EMERGENCY

Department of Health and Hospitals Bureau of Health Services Financing

Family Planning Waiver Reimbursement Rate Reduction (LAC 50:XXII.2701)

The Department of Health and Hospitals, Bureau of Health Services Financing amends LAC 50:XXII.2701 in the Medical Assistance Program as authorized by R.S. 36:254 and pursuant to Title XIX of the Social Security Act and as directed by House Bill 1 of the 2012 Regular Session of the Louisiana Legislature which states: "The secretary is directed to utilize various cost containment measures to ensure expenditures remain at the level appropriated in this Schedule, including but not limited to precertification, preadmission screening, diversion, fraud control, utilization review and management, prior authorization, service limitations, drug therapy management, disease management, cost sharing, and other measures as permitted under federal law." This Emergency Rule is promulgated in accordance with the provisions of the Administrative Procedure Act, R.S. 49:953(B)(1) et seq., and shall be in effect for the maximum period allowed under the Act or until adoption of the final Rule, whichever occurs first.

As a result of a budgetary shortfall in state fiscal year 2011, the Department of Health and Hospitals, Bureau of Health Services Financing amended the provisions governing the reimbursement methodology for family planning waiver services to reduce reimbursement rates (*Louisiana Register*, Volume 37, Number 7).

As a result of a budgetary shortfall in state fiscal year 2013, the Department of Health and Hospitals, Bureau of Health Services Financing promulgated an Emergency Rule which amended the provisions governing the reimbursement methodology for family planning waiver services in order to align the reimbursement rates in the waiver with the rates for family planning services provided under the Medicaid State Plan (*Louisiana Register*, Volume 38, Number 7). This Emergency Rule is being promulgated to continue the provisions of the July 1, 2012 Emergency Rule. This action is being taken to avoid a budget deficit in the medical assistance programs.

Effective October 30, 2012, the Department of Health and Hospitals, Bureau of Health Services Financing amends the provisions governing the reimbursement methodology for family planning waiver services.

Title 50

PUBLIC HEALTH—MEDICAL ASSISTANCE

Part XXII. 1115 Demonstration Waivers

Subpart 3. Family Planning Waiver

Chapter 27. Reimbursement

§2701. Reimbursement Methodology

A. - C. ...

D. Effective for dates of service on or after July 1, 2012, the reimbursement rates for the following Family Planning Waiver services shall be adjusted to be consistent with the reimbursement rates paid on the established Medicaid fee schedule for family planning services covered under the Medicaid State Plan in the Professional Services Program.

1. Rate adjustments shall be made to the following procedure codes:

a. Current Procedural Terminology (CPT) codes 00851, 36415, 58300, 58301, 58600, 58670, 58671, 71020, 80048, 80050, 80051, 82962, 86631, 86703, 87480, 87481, 87490, 87491, 87590, 87591, 87621, 87810, 87850, 88141, 88175, 88174, 93000, 99212, 99241, and 99242, 71010, 80061, 81000, 81001, 81002, 81003, 81005, 81025, 82948, 84520, 84550, 84702, 84703, 85014, 85018, 86592, 86593, 86689, 86701, 87070, 87075, 87081, 87110, and 87210.

AUTHORITY NOTE: Promulgated in accordance with R.S. 36:254 and Title XIX of the Social Security Act.

HISTORICAL NOTE: Promulgated by the Department of Health and Hospitals, Office of the Secretary, Bureau of Health Services Financing, LR 32:1461 (August 2006), amended by the Department of Health and Hospitals, Bureau of Health Services Financing, LR 36:2280 (October 2010), LR 37:2156 (July 2011), LR 38:

Implementation of the provisions of this Rule may be contingent upon the approval of the U.S. Department of Health and Human Services, Centers for Medicare and Medicaid Services (CMS), if it is determined that submission to CMS for review and approval is required.

Interested persons may submit written comments to J. Ruth Kennedy, Bureau of Health Services Financing, P.O. Box 91030, Baton Rouge, LA 70821-9030. She is responsible for responding to inquiries regarding this Emergency Rule. A copy of this Emergency Rule is available for review by interested parties at parish Medicaid offices.

Bruce D. Greenstein
Secretary

1210#070

DECLARATION OF EMERGENCY

Department of Health and Hospitals Bureau of Health Services Financing and Office of Aging and Adult Services

Home and Community-Based Services Waivers Adult Day Health Care—Reimbursement Rate Reduction (LAC 50:XXI.2915)

The Department of Health and Hospitals, Bureau of Health Services Financing and the Office of Aging and Adult Services amend LAC 50:XXI.2915 in the Medical Assistance Program as authorized by R.S. 36:254 and pursuant to Title XIX of the Social Security Act and as directed by House Bill 1 of the 2012 Regular Session of the Louisiana Legislature which states: "The secretary is directed to utilize various cost containment measures to ensure expenditures remain at the level appropriated in this Schedule, including but not limited to precertification, preadmission screening, diversion, fraud control, utilization review and management, prior authorization, service limitations, drug therapy management, disease management, cost sharing, and other measures as permitted under federal law." This Emergency Rule is promulgated in accordance with the provisions of the Administrative Procedure Act, R.S. 49:953(B)(1) et seq., and shall be in effect for the

maximum period allowed under the Act or until adoption of the final Rule, whichever occurs first.

As a result of a budgetary shortfall in state fiscal year 2011, the Department of Health and Hospitals, Bureau of Health Services Financing amended the provisions governing the reimbursement methodology for the ADHC Waiver to reduce the reimbursement rates (*Louisiana Register*, Volume 37, Number 9).

Due to a budgetary shortfall in state fiscal year 2013, the department promulgated an Emergency Rule which amended the provisions governing the reimbursement methodology for the Adult Day Health Care Waiver to reduce the reimbursement rates (*Louisiana Register*, Volume 38, Number 7). This Emergency Rule is being promulgated to continue the provisions of the July 1, 2012 Emergency Rule. This action is being taken to avoid a budget deficit in the medical assistance programs.

Effective October 30, 2012, the Department of Health and Hospitals, Bureau of Health Services Financing and the Office of Aging and Adult Services amend the provisions governing the Adult Day Health Care Waiver to reduce the reimbursement rates.

Title 50

PUBLIC HEALTH—MEDICAL ASSISTANCE

Part XXI. Home and Community-Based Services Waivers

Subpart 3. Adult Day Health Care

Chapter 29. Reimbursement

§2915. Provider Reimbursement

A. - F3. ...

G. Effective for dates of service on or after July 1, 2012, the reimbursement rates for ADHC services shall be reduced by 1.5 percent of the rates in effect on June 30, 2012.

1. The provider-specific transportation component shall be excluded from this rate reduction.

AUTHORITY NOTE: Promulgated in accordance with R.S. 36:254 and Title XIX of the Social Security Act.

HISTORICAL NOTE: Repromulgated by the Department of Health and Hospitals, Office of Aging and Adult Services, LR 34:2170 (October 2008), repromulgated LR 34:2575 (December 2008), amended by the Department of Health and Hospitals, Bureau of Health Services Financing and the Office of Aging and Adult Services, LR 37:2157 (July 2011), LR 37:2625 (September 2011), LR 38:

Implementation of the provisions of this Rule may be contingent upon the approval of the U.S. Department of Health and Human Services, Centers for Medicare and Medicaid Services (CMS), if it is determined that submission to CMS for review and approval is required.

Interested persons may submit written comments to J. Ruth Kennedy, Bureau of Health Services Financing, P.O. Box 91030, Baton Rouge, LA 70821-9030. She is responsible for responding to inquiries regarding this Emergency Rule. A copy of this Emergency Rule is available for review by interested parties at parish Medicaid offices.

Bruce D. Greenstein
Secretary

1210#071

DECLARATION OF EMERGENCY

Department of Health and Hospitals Bureau of Health Services Financing

Home and Community-Based Services Waivers Cost Reporting Requirements (LAC 50:XXI.Chapter 7)

The Department of Health and Hospitals, Bureau of Health Services Financing adopts LAC 50:XXI.Chapter 7 in the Medical Assistance Program as authorized by R.S. 36:254 and pursuant to Title XIX of the Social Security Act. This Emergency Rule is promulgated in accordance with the provisions of the Administrative Procedure Act, R.S. 49:953(B)(1) et seq., and shall be in effect for the maximum period allowed under the Act or until adoption of the final Rule, whichever occurs first.

Act 299 of the 2011 Regular Session of the Louisiana Legislature directed the Department of Health and Hospitals to establish mandatory cost reporting requirements for providers of home and community-based services to verify expenditures and for use in determining appropriate reimbursement rates. In compliance with Act 299, the department promulgated an Emergency Rule which adopted provisions establishing cost reporting requirements for providers of home and community-based waiver services (*Louisiana Register*, Volume 38, Number 7). This Emergency Rule is being promulgated to continue the provisions of the July 1, 2012 Emergency Rule. This action is being taken to promote the health and welfare of waiver participants and to ensure that these services are rendered in an efficient and cost-effective manner.

Effective October 30, 2012, the Department of Health and Hospitals, Bureau of Health Services Financing adopts provisions to establish cost reporting requirements for providers of home and community-based waiver services.

Title 50

PUBLIC HEALTH—MEDICAL ASSISTANCE

Part XXI. Home and Community Based Services Waivers

Subpart 1. General Provisions

Chapter 7. Cost Reporting Requirements

§701. General Provisions

A. Effective July 1, 2012, the department shall implement mandatory cost reporting requirements for providers of home and community-based waiver services. The cost reports will be used to verify expenditures and to support rate setting for the services rendered to waiver recipients.

B. Providers of services in the following waiver programs shall be required to submit cost reports:

1. adult day health care waiver;
2. children's choice waiver;
3. community choices waiver;
4. new opportunities waiver;
5. residential options waiver; and
6. supports waiver.

C. Each provider shall complete the DHH approved cost report and submit the cost report(s) to the department no later than five months after the state fiscal year ends (June 30).

AUTHORITY NOTE: Promulgated in accordance with R.S. 36:254 and Title XIX of the Social Security Act.

HISTORICAL NOTE: Promulgated by the Department of Health and Hospitals, Bureau of Health Services Financing, LR 38:

Implementation of the provisions of this Rule may be contingent upon the approval of the U.S. Department of Health and Human Services, Centers for Medicare and Medicaid Services (CMS), if it is determined that submission to CMS for review and approval is required.

Interested persons may submit written comments to J. Ruth Kennedy, Bureau of Health Services Financing, P.O. Box 91030, Baton Rouge, LA 70821-9030. She is responsible for responding to inquiries regarding this Emergency Rule. A copy of this Emergency Rule is available for review by interested parties at parish Medicaid offices.

Bruce D. Greenstein
Secretary

1210#072

DECLARATION OF EMERGENCY

Department of Health and Hospitals Bureau of Health Services Financing and Office of Aging and Adult Services

Home and Community-Based Services Waivers Repeal of Standards for Participation (LAC 50:XXI.Chapter 1)

The Department of Health and Hospitals, Bureau of Health Services Financing and the Office of Aging and Adult Services repeal LAC 50:XXI.Chapter 1 in the Medical Assistance Program as authorized by R.S. 36:254 and pursuant to Title XIX of the Social Security Act. This Emergency Rule is promulgated in accordance with the provisions of the Administrative Procedure Act, R.S. 49:953(B)(1) et seq., and shall be in effect for the maximum period allowed under the Act or until adoption of the final Rule, whichever occurs first.

The Department of Health and Hospitals, Office of the Secretary, Bureau of Community Supports and Services adopted provisions to establish minimum standards for participation for enrolled home and community-based services (HCBS) waiver providers, with the exception of adult day health care facilities (*Louisiana Register*, Volume 29, Number 9).

The Department of Health and Hospitals, Bureau of Health Services Financing and the Office of Aging and Adult Services promulgated an Emergency Rule which repealed the provisions governing the Standards for Participation for HCBS waiver providers as a result of the promulgation of new minimum licensing standards governing these providers which revise and stipulate the new participation requirements (*Louisiana Register*, Volume 37, Number 10). This Emergency Rule is being promulgated to continue the provisions of the November 1, 2011 Emergency Rule. This

action is being taken to avoid federal sanctions due to inconsistent minimum standards for HCBS waiver providers.

Effective October 29, 2012, the Department of Health and Hospitals, Bureau of Health Services Financing and the Office of Aging and Adult Services repeal the provisions governing the Standards for Participation for home and community-based services waiver providers.

Title 50

PUBLIC HEALTH—MEDICAL ASSISTANCE

Part XXI. Home and Community Based Services

Waivers

Subpart 1. General Provisions

Chapter 1. Standards for Participation

§101. Provider Requirements

Repealed.

AUTHORITY NOTE: Promulgated in accordance with R.S. 36:254 and Title XIX of the Social Security Act.

HISTORICAL NOTE: Promulgated by the Department of Health and Hospitals, Office of the Secretary, Bureau of Community Supports and Services, LR 29:1829 (September 2003), repealed by the Department of Health and Hospitals, Bureau of Health Services Financing and the Office of Aging and Adult Services, LR 38:

§103. Agency Responsibilities

Repealed.

AUTHORITY NOTE: Promulgated in accordance with R.S. 36:254 and Title XIX of the Social Security Act.

HISTORICAL NOTE: Promulgated by the Department of Health and Hospitals, Office of the Secretary, Bureau of Community Supports and Services, LR 29:1833 (September 2003), repealed by the Department of Health and Hospitals, Bureau of Health Services Financing and the Office of Aging and Adult Services, LR 38:

Implementation of the provisions of this Rule may be contingent upon the approval of the U.S. Department of Health and Human Services, Centers for Medicare and Medicaid Services (CMS), if it is determined that submission to CMS for review and approval is required.

Interested persons may submit written comments to J. Ruth Kennedy, Bureau of Health Services Financing, P.O. Box 91030, Baton Rouge, LA 70821-9030. She is responsible for responding to inquiries regarding this Emergency Rule. A copy of this Emergency Rule is available for review by interested parties at parish Medicaid offices.

Bruce D. Greenstein
Secretary

1210#074

DECLARATION OF EMERGENCY

Department of Health and Hospitals Bureau of Health Services Financing and

Office for Citizens with Developmental Disabilities

Home and Community-Based Services Waivers Residential Options Waiver—Reimbursement Rate Reduction (LAC 50:XXI.16901)

The Department of Health and Hospitals, Bureau of Health Services Financing and the Office for Citizens with Developmental Disabilities amend LAC 50:XXI.16901

under the Medical Assistance Program as authorized by R.S. 36:254 and pursuant to Title XIX of the Social Security Act and as directed by House Bill 1 of the 2012 Regular Session of the Louisiana Legislature which states: "The secretary is directed to utilize various cost containment measures to ensure expenditures remain at the level appropriated in this Schedule, including but not limited to precertification, preadmission screening, diversion, fraud control, utilization review and management, prior authorization, service limitations, drug therapy management, disease management, cost sharing, and other measures as permitted under federal law." This Emergency Rule is promulgated in accordance with the provisions of the Administrative Procedure Act, R.S. 49:953(B) (1) et seq., and shall be in effect for the maximum period allowed under the Act or until adoption of the final Rule, whichever occurs first.

The Department of Health and Hospitals, Bureau of Health Services and the Office for Citizens with Developmental Disabilities promulgated an Emergency Rule which amended the provisions governing the Residential Options Waiver (ROW) to revise the provisions governing the allocation of waiver opportunities and the delivery of services in order to provide greater clarity (*Louisiana Register*, Volume 36, Number 4).

Due to a budgetary shortfall in state fiscal year 2013, the department promulgated an Emergency Rule which amended the provisions governing the reimbursement methodology for the Residential Options Waiver to reduce the reimbursement rates (*Louisiana Register*, Volume 38, Number 7). This Emergency Rule is being promulgated to continue the provisions of the July 1, 2012 Emergency Rule. This action is being taken to avoid a budget deficit in the medical assistance programs.

Effective October 30, 2012, the Department of Health and Hospitals, Bureau of Health Services Financing and the Office for Citizens with Developmental Disabilities amend the provisions governing the reimbursement methodology for the Residential Options Waiver to reduce the reimbursement rates.

Title 50

PUBLIC HEALTH—MEDICAL ASSISTANCE Part XXI. Home and Community Based Services

Waivers

Subpart 13. Residential Options Waiver

Chapter 169. Reimbursement

§16901. Reimbursement Methodology

A. K.1.d. ...

L. Effective for dates of service on or after July 1, 2012, the reimbursement for Residential Options Waiver services shall be reduced by 1.5 percent of the rates in effect on June 30, 2012.

1. The following services shall be excluded from this rate reduction:

- a. personal emergency response services;
- b. environmental accessibility adaption services;
- c. specialized medical equipment and supplies; and
- d. transitional services.

AUTHORITY NOTE: Promulgated in accordance with R.S. 36:254 and Title XIX of the Social Security Act.

HISTORICAL NOTE: Promulgated by the Department of Health and Hospitals, Office for Citizens with Developmental Disabilities, LR 33:2456 (November 2007), amended by the Department of Health and Hospitals, Bureau of Health Services

Financing and the Office for Citizens with Developmental Disabilities, LR 38:

Implementation of the provisions of this Rule may be contingent upon the approval of the U.S. Department of Health and Human Services, Centers for Medicare and Medicaid Services (CMS), if it is determined that submission to CMS for review and approval is required.

Interested persons may submit written comments to J. Ruth Kennedy, Bureau of Health Services Financing, P.O. Box 91030, Baton Rouge, LA 70821-9030. She is responsible for responding to inquiries regarding this Emergency Rule. A copy of this Emergency Rule is available for review by interested parties at parish Medicaid offices.

Bruce D. Greenstein
Secretary

1210#073

DECLARATION OF EMERGENCY

Department of Health and Hospitals Bureau of Health Services Financing and

Office for Citizens with Developmental Disabilities

Home and Community-Based Services Waivers
Supports Waiver
Reimbursement Rate Reduction
(LAC 50:XXI.6101)

The Department of Health and Hospitals, Bureau of Health Services Financing and the Office for Citizens with Developmental Disabilities amend LAC 50:XXI.6101 in the Medical Assistance Program as authorized by R.S. 36:254 and pursuant to Title XIX of the Social Security Act and as directed by House Bill 1 of the 2012 Regular Session of the Louisiana Legislature which states: "The secretary is directed to utilize various cost containment measures to ensure expenditures remain at the level appropriated in this Schedule, including but not limited to precertification, preadmission screening, diversion, fraud control, utilization review and management, prior authorization, service limitations, drug therapy management, disease management, cost sharing, and other measures as permitted under federal law." This Emergency Rule is promulgated in accordance with the provisions of the Administrative Procedure Act, R.S. 49:953(B)(1) et seq., and shall be in effect for the maximum period allowed under the Act or until adoption of the final Rule, whichever occurs first.

As a result of a budgetary shortfall in state fiscal year 2011, the department amended the provisions governing the reimbursement methodology for Supports Waiver services to reduce the reimbursement rates (*Louisiana Register*, Volume 37, Number 7).

Due to a budgetary shortfall in state fiscal year 2013, the Department of Health and Hospitals, Bureau of Health Services Financing and the Office for Citizens with Developmental Disabilities promulgated an Emergency Rule which amended the provisions governing the reimbursement methodology for Supports Waiver services to reduce the reimbursement rates (*Louisiana Register*, Volume 38, Number 7). This Emergency Rule is being promulgated to continue the provisions of the July 1, 2012 Emergency Rule.

This action is being taken to avoid a budget deficit in the medical assistance programs.

Effective October 30, 2012, the Department of Health and Hospitals, Bureau of Health Services Financing and the Office for Citizens with Developmental Disabilities amend the provisions governing the reimbursement methodology for Supports Waiver services to reduce the reimbursement rates.

Title 50

PUBLIC HEALTH-MEDICAL ASSISTANCE

Part XXI. Home and Community Based Services

Waivers

Subpart 5. Supports Waiver

Chapter 61. Reimbursement Methodology

§6101. Reimbursement Methodology

A. - L.1. ...

M. Effective for dates of service on or after July 1, 2012, the reimbursement rates for Supports Waiver services shall be reduced by 1.5 percent of the rates on file as of June 30, 2012.

1. Personal emergency response system services shall be excluded from the rate reduction.

AUTHORITY NOTE: Promulgated in accordance with R.S. 36:254 and Title XIX of the Social Security Act.

HISTORICAL NOTE: Promulgated by the Department of Health and Hospitals, Office of the Secretary, Office for Citizens with Developmental Disabilities, LR 32:1607 (September 2006), amended LR 34:662 (April 2008), amended by the Department of Health and Hospitals, Bureau of Health Services Financing and the Office for Citizens with Developmental Disabilities, LR 36:2281 (October 2010), amended LR 37:2158 (July 2011), LR 38:

Implementation of the provisions of this Rule may be contingent upon the approval of the U.S. Department of Health and Human Services, Centers for Medicare and Medicaid Services (CMS), if it is determined that submission to CMS for review and approval is required.

Interested persons may submit written comments to J. Ruth Kennedy, Bureau of Health Services Financing, P.O. Box 91030, Baton Rouge, LA 70821-9030. She is responsible for responding to inquiries regarding this Emergency Rule. A copy of this Emergency Rule is available for review by interested parties at parish Medicaid offices.

Bruce D. Greenstein
Secretary

1210#075

DECLARATION OF EMERGENCY

**Department of Health and Hospitals
Bureau of Health Services Financing**

Home Health Program—Durable Medical Equipment
Reimbursement Rate Reduction (LAC 50:XIII.10301)

The Department of Health and Hospitals, Bureau of Health Services Financing amends LAC 50:XIII.10301 in the Medical Assistance Program as authorized by R.S. 36:254 and pursuant to Title XIX of the Social Security Act and as directed by House Bill 1 of the 2012 Regular Session of the Louisiana Legislature which states: “The secretary is directed to utilize various cost containment measures to ensure expenditures remain at the level appropriated in this Schedule, including but not limited to precertification,

preadmission screening, diversion, fraud control, utilization review and management, prior authorization, service limitations, drug therapy management, disease management, cost sharing, and other measures as permitted under federal law.” This Emergency Rule is promulgated in accordance with the provisions of the Administrative Procedure Act, R.S. 49:953(B)(1) et seq., and shall be in effect for the maximum period allowed under the Act or until adoption of the final Rule, whichever occurs first.

As a result of a budgetary shortfall in state fiscal year 2010, the Department of Health and Hospitals, Bureau of Health Services Financing amended the provisions governing the reimbursement methodology for medical equipment, supplies and appliances to reduce the reimbursement rates (*Louisiana Register*, Volume 36, Number 9). Due to a budgetary shortfall in state fiscal year 2013, the department promulgated an Emergency Rule which amended the provisions governing the reimbursement methodology for medical equipment, supplies and appliances to reduce the reimbursement rates (*Louisiana Register*, Volume 38, Number 7). This Emergency Rule is being promulgated to continue the provisions of the July 1, 2012 Emergency Rule.

This action is being taken to avoid a budget deficit in the medical assistance programs.

Effective October 30, 2012, the Department of Health and Hospitals, Bureau of Health Services Financing amends the provisions governing the reimbursement methodology for medical equipment, supplies and appliances to reduce the reimbursement rates.

Title 50

PUBLIC HEALTH—MEDICAL ASSISTANCE

Part XIII. Home Health Program

Subpart 3. Medical Equipment, Supplies and Appliances

Chapter 103. Reimbursement Methodology

§10301. General Provisions

A. - E.2. ...

F. Effective for dates of service on or after July 1, 2012, the reimbursement paid for medical equipment, supplies and appliances shall be reduced by 3.7 percent of the rates on file as of June 30, 2012.

AUTHORITY NOTE: Promulgated in accordance with R.S. 36:254 and Title XIX of the Social Security Act.

HISTORICAL NOTE: Promulgated by the Department of Health and Hospitals, Bureau of Health Services Financing, LR 35:1894 (September 2009), amended LR 36:1247 (June 2010), LR 36:2041 (September 2010), LR 38:

Implementation of the provisions of this Rule may be contingent upon the approval of the U.S. Department of Health and Human Services, Centers for Medicare and Medicaid Services (CMS), if it is determined that submission to CMS for review and approval is required.

Interested persons may submit written comments to J. Ruth Kennedy, Bureau of Health Services Financing, P.O. Box 91030, Baton Rouge, LA 70821-9030. She is responsible for responding to inquiries regarding this Emergency Rule. A copy of this Emergency Rule is available for review by interested parties at parish Medicaid offices.

Bruce D. Greenstein
Secretary

1210#076

DECLARATION OF EMERGENCY

Department of Health and Hospitals Bureau of Health Services Financing

Home Health Program
Nursing and Home Health Aide Services
Reimbursement Rate Reduction
(LAC 50:XIII.701)

The Department of Health and Hospitals, Bureau of Health Services Financing amends LAC 50:XIII.701 in the Medical Assistance Program as authorized by R.S. 36:254 and pursuant to Title XIX of the Social Security Act and as directed by House Bill 1 of the 2012 Regular Session of the Louisiana Legislature which states: "The secretary is directed to utilize various cost containment measures to ensure expenditures remain at the level appropriated in this Schedule, including but not limited to precertification, preadmission screening, diversion, fraud control, utilization review and management, prior authorization, service limitations, drug therapy management, disease management, cost sharing, and other measures as permitted under federal law." This Emergency Rule is promulgated in accordance with the provisions of the Administrative Procedure Act, R. S. 49:953(B)(1) et seq., and shall be in effect for the maximum period allowed under the Act or until adoption of the final Rule, whichever occurs first

As a result of a budgetary shortfall in state fiscal year 2011, the Department of Health and Hospitals, Bureau of Health Services Financing amended the provisions governing the reimbursement methodology for nursing services covered in the Home Health Program in order to reduce the reimbursement rates paid for extended nursing services (*Louisiana Register*, Volume 37, Number 7).

Due to a budgetary shortfall in state fiscal year 2013, the Department of Health and Hospitals, Bureau of Health Services Financing promulgated an Emergency Rule which amended the provisions governing the reimbursement methodology for intermittent and extended nursing services and home health aide services covered in the Home Health Program in order to reduce the reimbursement rates (*Louisiana Register*, Volume 38, Number 7). This Emergency Rule is being promulgated to continue the provisions of the July 1, 2012 Emergency Rule. This action is being taken to avoid a budget deficit in the medical assistance programs.

Effective October 30, 2012, the Department of Health and Hospitals, Bureau of Health Services Financing amends the provisions governing the reimbursement methodology for nursing and home health aide services covered in the Home Health Program to reduce the reimbursement rates.

Title 50

PUBLIC HEALTH—MEDICAL ASSISTANCE

Part XIII. Home Health

Subpart 1. Home Health Services

Chapter 7. Reimbursement Methodology

§701. Nursing and Home Health Aide Services

A. - C. ...

D. Effective for dates of service on or after July 1, 2012, the reimbursement rates for intermittent and extended nursing services and home health aide services shall be

reduced by 3.7 percent of the rates in effect on June 30, 2012.

AUTHORITY NOTE: Promulgated in accordance with R.S. 36:254 and Title XIX of the Social Security Act.

HISTORICAL NOTE: Promulgated by the Department of Health and Hospitals, Office of the Secretary, Bureau of Health Services Financing, LR 34:654 (April 2008), amended by the Department of Health and Hospitals, Bureau of Health Services Financing, LR 36:2281 (October 2010), amended LR 37:2159 (July 2011), LR 38:

Implementation of the provisions of this Rule may be contingent upon the approval of the U.S. Department of Health and Human Services, Centers for Medicare and Medicaid Services (CMS), if it is determined that submission to CMS for review and approval is required.

Interested persons may submit written comments to J. Ruth Kennedy, Bureau of Health Services Financing, P.O. Box 91030, Baton Rouge, LA 70821-9030. She is responsible for responding to inquiries regarding this Emergency Rule. A copy of this Emergency Rule is available for review by interested parties at parish Medicaid offices.

Bruce D. Greenstein
Secretary

1210#078

DECLARATION OF EMERGENCY

Department of Health and Hospitals Bureau of Health Services Financing

Home Health Services
Cost Reporting Requirements
(LAC 50:XIII.Chapter 1)

The Department of Health and Hospitals, Bureau of Health Services Financing adopts LAC 50:XIII.Chapter 1 in the Medical Assistance Program as authorized by R.S. 36:254 and pursuant to Title XIX of the Social Security Act. This Emergency Rule is promulgated in accordance with the provisions of the Administrative Procedure Act, R.S. 49:953(B)(1) et seq., and shall be in effect for the maximum period allowed under the Act or until adoption of the final Rule, whichever occurs first.

Act 299 of the 2011 Regular Session of the Louisiana Legislature directed the Department of Health and Hospitals to establish mandatory cost reporting requirements for providers of home and community-based services to verify expenditures and for use in determining appropriate reimbursement rates. In compliance with Act 299, the department promulgated an Emergency Rule which adopted provisions establishing cost reporting requirements for providers of home health services (*Louisiana Register*, Volume 38, Number 7). This Emergency Rule is being promulgated to continue the provisions of the July 1, 2012 Emergency Rule.

This action is being taken to promote the health and welfare of Medicaid recipients and to ensure that these services are rendered in an efficient and cost-effective manner.

Effective October 30, 2012, the Department of Health and Hospitals, Bureau of Health Services Financing adopts provisions to establish cost reporting requirements for providers of home health services.

Title 50
PUBLIC HEALTH—MEDICAL ASSISTANCE
Part XIII. Home Health
Subpart 1. Home Health Services

Chapter 1. General Provisions

§121. Cost Reporting Requirements

A. Effective July 1, 2012, the department shall implement mandatory cost reporting requirements for providers of home health services. The cost reports will be used to verify expenditures and to support rate setting for the services rendered to Medicaid recipients.

B. Each home health agency shall complete the DHH approved cost report and submit the cost report(s) to the department no later than five months after the state fiscal year ends (June 30).

AUTHORITY NOTE: Promulgated in accordance with R.S. 36:254 and Title XIX of the Social Security Act.

HISTORICAL NOTE: Promulgated by the Department of Health and Hospitals, Bureau of Health Services Financing, LR 38:

Implementation of the provisions of this Rule may be contingent upon the approval of the U.S. Department of Health and Human Services, Centers for Medicare and Medicaid Services (CMS), if it is determined that submission to CMS for review and approval is required.

Interested persons may submit written comments to J. Ruth Kennedy, Bureau of Health Services Financing, P.O. Box 91030, Baton Rouge, LA 70821-9030. She is responsible for responding to inquiries regarding this Emergency Rule. A copy of this Emergency Rule is available for review by interested parties at parish Medicaid offices.

Bruce D. Greenstein
Secretary

1210#077

DECLARATION OF EMERGENCY

Department of Health and Hospitals
Bureau of Health Services Financing

Hospice Services (LAC 50:XV.3301, Chapter 35, 3701,
3703, 3901, 4101, Chapter 43)

The Department of Health and Hospitals, Bureau of Health Services Financing, amends LAC 50:XV. 3301, Chapter 35, 3701, 3703, 3901, 4101, Chapter 43 under the Medical Assistance Program as authorized by R.S. 36:254 and pursuant to Title XIX of the Social Security Act. This Emergency Rule is promulgated in accordance with the provisions of the Administrative Procedure Act, R.S. 49:953(B)(1) et seq., and shall be in effect for the maximum period allowed under the Act or until adoption of the final Rule, whichever occurs first.

As a result of a budgetary shortfall in state fiscal year 2009, the Department of Health and Hospitals, Bureau of Health Services Financing amended the provisions governing the reimbursement methodology for hospice services provided to long-term care residents to reduce the reimbursement rates (*Louisiana Register*, Volume 35, Number 9).

The Department of Health and Hospitals, Bureau of Health Services Financing promulgated an Emergency Rule which amended the provisions governing hospice services in

order to bring these provisions into compliance with the requirements of the Patient Protection and Affordable Care Act (PPACA) and also amended the provisions governing prior authorization for hospice services in order to control the escalating costs associated with the Hospice Program (*Louisiana Register*, Volume 38, Number 3). This Emergency Rule is being promulgated to continue the provisions of the May 1, 2012 Emergency Rule. This action is being taken to avoid sanctions from the U.S. Department of Health and Human Services, Centers for Medicare and Medicaid Services for noncompliance with PPACA requirements, and to avoid a budget deficit in the medical assistance programs.

Effective November 17, 2012, the Department of Health and Hospitals, Bureau of Health Services Financing amends the provisions governing the Hospice Program.

Title 50
PUBLIC HEALTH—MEDICAL ASSISTANCE
Part XV. Services for Special Populations
Subpart 3. Hospice

Chapter 33. Provider Participation

§3301. Conditions for Participation

A. Statutory Compliance

1. Coverage of Medicaid hospice care shall be in accordance with:

a. 42 USC 1396d(o); and

b. the Medicare Hospice Program guidelines as set forth in 42 CFR Part 418.

B. ...

AUTHORITY NOTE: Promulgated in accordance with R.S. 36:254.

HISTORICAL NOTE: Promulgated by the Department of Health and Hospitals, Office of the Secretary, Bureau of Health Services Financing, LR 28:1466 (June 2002), amended LR 30:1024 (May 2004), amended by the Department of Health and Hospitals, Bureau of Health Services Financing, LR 38:

Chapter 35. Recipient Eligibility

§3501. Election of Hospice Care

A. - F. ...

G. Election Statement Requirements. The election statement must include:

1. identification of the particular hospice that will provide care to the individual;

2. the individual's or his/her legal representative's acknowledgment that he or she has been given a full understanding of the palliative rather than curative nature of hospice care, as it relates to the individual's terminal illness;

3. acknowledgment that certain Medicaid services, as set forth in §3503 are waived by the election;

4. the effective date of the election, which may be the first day of hospice care or a later date, but may be no earlier than the date of the election statement; and

5. the signature of the individual or his/her legal representative.

H. Duration of Election. An election to receive hospice care will be considered to continue through the initial election period and through the subsequent election periods without a break in care as long as the individual:

1. remains in the care of a hospice;

2. does not revoke the election under the provisions of §3505; and

3. is not discharged from hospice in accordance with §3505.

AUTHORITY NOTE: Promulgated in accordance with R.S. 36:254.

HISTORICAL NOTE: Promulgated by the Department of Health and Hospitals, Office of the Secretary, Bureau of Health Services Financing, LR 19:749 (June 1993), amended LR 28:1466 (June 2002), amended by the Department of Health and Hospitals, Bureau of Health Services Financing, LR 38:

§3503. Waiver of Payment for Other Services

A. - A.2.c. ...

B. Individuals who are approved to receive hospice may not receive any other non-waiver home and community-based services, such as long-term personal care services, while they are receiving hospice.

AUTHORITY NOTE: Promulgated in accordance with R.S. 36:254.

HISTORICAL NOTE: Promulgated by the Department of Health and Hospitals, Office of the Secretary, Bureau of Health Services Financing, LR 28:1467 (June 2002), amended by the Department of Health and Hospitals, Bureau of Health Services Financing, LR 38:

§3505. Revoking the Election of Hospice Care/Discharge

A. - A.4. ...

5. Re-election of Hospice Benefits. If an election has been revoked in accordance with the provisions of this §3505, the individual or his/her representative may at any time file an election, in accordance with §3501, for any other election period that is still available to the individual.

AUTHORITY NOTE: Promulgated in accordance with R.S. 36:254.

HISTORICAL NOTE: Promulgated by the Department of Health and Hospitals, Office of the Secretary, Bureau of Health Services Financing, LR 28:1467 (June 2002), amended by the Department of Health and Hospitals, Bureau of Health Services Financing, LR 38:

Chapter 37. Provider Requirements

§3701. Requirements for Coverage

A. To be covered, a certification of terminal illness must be completed as set forth in §3703, the election of hospice care form must be completed in accordance with §3501, and a plan of care must be established in accordance with §3705. A written narrative from the referring physician explaining why the patient has a prognosis of six months or less must be included in the certificate of terminal illness. Prior authorization requirements stated in Chapter 41 of these provisions are applicable to all election periods.

AUTHORITY NOTE: Promulgated in accordance with R.S. 36:254.

HISTORICAL NOTE: Promulgated by the Department of Health and Hospitals, Office of the Secretary, Bureau of Health Services Financing, LR 28:1467 (June 2002), amended by the Department of Health and Hospitals, Bureau of Health Services Financing, LR 38:

§3703. Certification of Terminal Illness

A. - A.1.a. ...

b. For the first 90-day period of hospice coverage, the hospice must obtain a verbal certification no later than two calendar days after hospice care is initiated. If the verbal certification is not obtained within two calendar days following the initiation of hospice care, a written certification must be made within ten calendar days following the initiation of hospice care. The written certification and notice of election must be obtained before requesting prior authorization for hospice care. If these requirements are not met, no payment is made for the days

prior to the certification. Instead, payment begins with the day of certification, i.e., the date all certification forms are obtained.

c. For the subsequent periods, a written certification must be included in an approved prior authorization packet before a claim may be billed.

2. - 2.c....

d. If verbal certification is made, the referral from the physician shall be received by a member of the hospice interdisciplinary group (IDG). The entry in the patient's clinical record of the verbal certification shall include, at a minimum:

i. - ii. ...

iii. terminal diagnosis(es) and all other diagnosis(es);

iv. - v. ...

3. Face-to-Face Encounter

a. A hospice physician or hospice nurse practitioner must have a face-to-face encounter with each hospice patient whose total stay across all hospices is anticipated to reach the third benefit period. The face-to-face encounter must occur prior to, but no more than 30 calendar days prior to, the third benefit period recertification, and every benefit period recertification thereafter, to gather clinical findings to determine continued eligibility for hospice care.

b. The physician or nurse practitioner who performs the face-to-face encounter with the patient must attest in writing that he or she had a face-to-face encounter with the patient, including the date of that visit. The attestation of the nurse practitioner or a non-certifying hospice physician shall state that the clinical findings of that visit were provided to the certifying physician for use in determining continued eligibility for hospice care.

4. Content of Certifications

a. Certification will be based on the physician's or medical director's clinical judgment regarding the normal course of the individual's illness. The certification must conform to the following requirements.

i. The certification must specify that the individual's prognosis is for a life expectancy of six months or less if the terminal illness runs its normal course.

ii. Written clinical information and other documentation that support the medical prognosis must accompany the certification and must be filed in the medical record with the written certification, as set forth in Paragraph 4 of this Subsection.

iii. The physician must include a brief written narrative explanation of the clinical findings that support a life expectancy of six months or less as part of the certification and recertification forms, or as an addendum to the certification and recertification forms.

(a). The narrative must reflect the patient's individual clinical circumstances and cannot contain check boxes or standard language used for all patients.

(b). The narrative associated with the third benefit period recertification and every subsequent recertification must include an explanation of why the clinical findings of the face-to-face encounter support a life expectancy of six months or less, and shall not be the same narrative as previously submitted.

b. All certifications and recertifications must be signed and dated by the physician(s), and must include the

benefit period dates to which the certification or recertification applies.

5. Sources of Certification

a. For the initial 90-day period, the hospice must obtain written certification statements as provided in §3703.A.1 from:

i. ...

ii. the individual's attending physician.

(a). The attending physician is a doctor of medicine or osteopathy and is identified by the individual, at the time he or she elects to receive hospice care, as having the most significant role in the determination and delivery of the individual's medical care.

(b). The attending physician is the physician identified within the Medicaid system as the provider to which claims have been paid for services prior to the time of the election of hospice benefits.

b. ...

6. Maintenance of Records. Hospice staff must make an appropriate entry in the patient's clinical record as soon as they receive an oral certification and file written certifications in the clinical record.

AUTHORITY NOTE: Promulgated in accordance with R.S. 36:254.

HISTORICAL NOTE: Promulgated by the Department of Health and Hospitals, Office of the Secretary, Bureau of Health Services Financing, LR 19:749 (June 1993), amended LR 28:1468 (June 2002), amended by the Department of Health and Hospitals, Bureau of Health Services Financing, LR 38:

Chapter 39. Covered Services

§3901. Medical and Support Services

A. - 11.b.iv. ...

c. Inpatient Respite Care Day. An inpatient respite care day is a day on which the individual receives care in an approved facility on a short-term basis, not to exceed five days in any one election period, to relieve the family members or other persons caring for the individual at home. An approved facility is one that meets the standards as provided in 42 CFR §418.98(b). This service cannot be delivered to individuals already residing in a nursing facility.

d. General Inpatient Care Day. A general inpatient care day is a day on which an individual receives general inpatient care in an inpatient facility that meets the standards as provided in 42 CFR §418.98(a) and for the purpose of pain control or acute or chronic symptom management which cannot be managed in other settings. General inpatient care shall not exceed five days in any one election period.

AUTHORITY NOTE: Promulgated in accordance with R.S. 36:254.

HISTORICAL NOTE: Promulgated by the Department of Health and Hospitals, Office of the Secretary, Bureau of Health Services Financing, LR 28:1468 (June 2002), amended by the Department of Health and Hospitals, Bureau of Health Services Financing, LR 38:

Chapter 41. Prior Authorization

§4101. Prior Authorization of Hospice Services

A. Prior authorization is required for all election periods as specified in §3501.C. The prognosis of terminal illness will be reviewed. A patient must have a terminal prognosis and not just certification of terminal illness. Authorization will be made on the basis that a patient is terminally ill as defined in federal regulations. These regulations require

certification of the patient's prognosis, rather than diagnosis. Authorization will be based on objective clinical evidence contained in the clinical record which supports the medical prognosis that the patient's life expectancy is six months or less if the illness runs its normal course and not simply on the patient's diagnosis.

1. Providers shall submit the appropriate forms and documentation required for prior authorization of hospice services as designated by the department in the Medicaid Program's service and provider manuals, memorandums, etc.

B. Written Notice of Denial. In the case of a denial, a written notice of denial shall be submitted to the hospice, recipient, and nursing facility, if appropriate.

1. Claims will only be paid from the date of the hospice notice of election if the prior authorization request is received within 10 days from the date of election and is approved. If the prior authorization request is received 10 days or more after the date on the hospice notice of election, the approved begin date for hospice services is the date the completed prior authorization packet is received.

C. Appeals. If the hospice or the recipient does not agree with the denial of a hospice prior authorization request, the recipient, or the hospice on behalf of the recipient, can request an appeal of the prior authorization decision. The appeal request must be filed with the Division of Administrative Law within 30 days from the date of the postmark on the denial letter. The appeal proceedings will be conducted in accordance with the Administrative Procedure Act.

AUTHORITY NOTE: Promulgated in accordance with R.S. 36:254.

HISTORICAL NOTE: Promulgated by the Department of Health and Hospitals, Office of the Secretary, Bureau of Health Services Financing, LR 28:1470 (June 2002), amended by the Department of Health and Hospitals, Bureau of Health Services Financing, LR 38:

Chapter 43. Reimbursement

§4303. Levels of Care for Payment

A. - B.3....

C. Inpatient Respite Care. The inpatient respite care rate is paid for each day the recipient is in an approved inpatient facility and is receiving respite care (see §3901.A.11.c). Respite care may be provided only on an occasional basis and payment for respite care may be made for a maximum of five days at a time including the date of admission but not counting the date of discharge. Payment for the day of discharge in a respite setting shall be at the routine home level-of-care discharged alive rate.

1. ...

2. Respite care may not be provided when the hospice patient is a nursing home resident, regardless of the setting, i.e., long-term acute care setting.

D. General Inpatient Care. Payment at the inpatient rate is made when an individual receives general inpatient care in an inpatient facility for pain control or acute or chronic symptom management which cannot be managed in other settings. General inpatient care is a short-term level of care and is not intended to be a permanent solution to a negligent or absent caregiver. A lower level of care must be used once symptoms are under control. General inpatient care and nursing facility or intermediate care facility for persons with

intellectual disabilities room and board cannot be reimbursed for the same recipient on the same covered days of service. Payment for general inpatient care may be made for a maximum of five days at a time, including the date of admission, but not counting the date of discharge. Payment for the day of discharge in a general inpatient setting shall be at the routine home level-of-care discharged alive rate.

1. - 2. ...

AUTHORITY NOTE: Promulgated in accordance with R.S. 36:254.

HISTORICAL NOTE: Promulgated by the Department of Health and Hospitals, Office of the Secretary, Bureau of Health Services Financing, LR 28:1470 (June 2002), amended by the Department of Health and Hospitals, Bureau of Health Services Financing, LR 38:

§4305. Hospice Payment Rates

A. - A.2. ...

a. The hospice is paid for other physicians' services, such as direct patient care services, furnished to individual patients by hospice employees and for physician services furnished under arrangements made by the hospice unless the patient care services were furnished on a volunteer basis. The physician visit for the face-to-face encounter will not be reimbursed by the Medicaid Program.

b. - d.ii. ...

AUTHORITY NOTE: Promulgated in accordance with R.S. 36:254.

HISTORICAL NOTE: Promulgated by the Department of Health and Hospitals, Office of the Secretary, Bureau of Health Services Financing, LR 28:1470 (June 2002), LR 34:441 (March 2008), amended by the Department of Health and Hospitals, Bureau of Health Services Financing, LR 38:

§4309. Limitation on Payments for Inpatient Care

A. ...

1. During the 12-month period beginning November 1 of each year and ending October 31, the number of inpatient days (both for general inpatient care and inpatient respite care) for any one hospice recipient may not exceed five days per occurrence.

2. - 2.b....

AUTHORITY NOTE: Promulgated in accordance with R.S. 36:254.

HISTORICAL NOTE: Promulgated by the Department of Health and Hospitals, Office of the Secretary, Bureau of Health Services Financing, LR 28:1472 (June 2002), amended by the Department of Health and Hospitals, Bureau of Health Services Financing, LR 38:

Implementation of the provisions of this Rule may be contingent upon the approval of the U.S. Department of Health and Human Services, Centers for Medicare and Medicaid Services (CMS), if it is determined that submission to CMS for review and approval is required.

Interested persons may submit written comments to J. Ruth Kennedy, Bureau of Health Services Financing, P.O. Box 91030, Baton Rouge, LA 70821-9030. She is responsible for responding to inquiries regarding this Emergency Rule. A copy of this Emergency Rule is available for review by interested parties at parish Medicaid offices.

Bruce D. Greenstein
Secretary

1210#079

DECLARATION OF EMERGENCY

Department of Health and Hospitals Bureau of Health Services Financing

Inpatient Hospital Services
Major Teaching Hospitals
Supplemental Payments
(LAC 50:V.1333)

The Department of Health and Hospitals, Bureau of Health Services Financing adopts LAC 50:V.1333 in the Medical Assistance Program as authorized by R.S. 36:254 and pursuant to Title XIX of the Social Security Act. This Emergency Rule is promulgated in accordance with the provisions of the Administrative Procedure Act, R.S. 49:953.B(1) et seq., and shall be in effect for the maximum period allowed under the Act or until adoption of the final Rule, whichever occurs first.

The Department of Health and Hospitals, Office of the Secretary, Bureau of Health Services Financing amended the provisions governing the reimbursement methodology for inpatient hospital services to provide for a supplemental Medicaid payment to non-rural, non-state acute care hospitals for having a Medicaid inpatient utilization greater than 30 percent and teaching hospitals for furnishing additional graduate medical education services as a result of the suspension of training programs at the Medical Center of Louisiana at New Orleans due to the impact of Hurricane Katrina (*Louisiana Register*, Volume 34, Number 5).

The Department of Health and Hospitals, Bureau of Health Services Financing promulgated an Emergency Rule which amended the provisions governing the reimbursement methodology for inpatient hospital services to provide a supplemental Medicaid payment to acute care hospitals designated as major teaching hospitals to facilitate the development of public-private collaborations in order to preserve access to medically necessary services for Medicaid recipients (*Louisiana Register*, Volume 37, Number 6). This Emergency Rule is being promulgated to continue the provisions of the July 1, 2011 Emergency Rule. This action is being taken to promote the health and welfare of Medicaid recipients by encouraging provider participation in the Medicaid Program so as to assure sufficient access to hospital services.

Effective October 26, 2012, the Department of Health and Hospitals, Bureau of Health Services Financing amends the provisions governing the reimbursement methodology for inpatient hospital services rendered by non-rural, non-state hospitals designated as major teaching hospitals.

Title 50

PUBLIC HEALTH—MEDICAL ASSISTANCE

Part V. Hospital Services

Subpart 1. Inpatient Hospitals

Chapter 13. Teaching Hospitals

Subchapter B. Reimbursement Methodology

§1333. Major Teaching Hospitals

A. ...

B. Effective for dates of service on or after July 1, 2011, a quarterly supplemental payment shall be issued to non-rural, non-state acute care hospitals for inpatient services

rendered during the quarter. These payments shall be used to facilitate the development of public-private collaborations to preserve access to medically necessary services for Medicaid recipients. Aggregate payments to qualifying hospitals shall not exceed the maximum allowable cap for the quarter.

1. Qualifying Criteria. In order to qualify for the supplemental payments the non-rural, non-state acute care hospital must:

- a. be designated as a major teaching hospital by the Department of Health and Hospitals in state fiscal year 2011;
- b. have provided at least 25,000 Medicaid acute care paid days for state fiscal year 2010 dates of service; and
- c. have provided at least 5,000 Medicaid distinct part psychiatric unit paid days for state fiscal year 2010 dates of service.

2. Payments shall be distributed quarterly and shall be calculated using the Medicaid paid days for service dates in state fiscal year 2010 as a proxy for SFY 2012 service dates.

3. Payments are applicable to Medicaid service dates provided during the first quarter of state fiscal year 2012 only and shall not exceed \$14,000,000.

AUTHORITY NOTE: Promulgated in accordance with R.S. 36:254 and Title XIX of the Social Security Act.

HISTORICAL NOTE: Promulgated by the Department of Health and Hospitals, Bureau of Health Services Financing, LR 38:

Interested persons may submit written comments to J. Ruth Kennedy, Bureau of Health Services Financing, P.O. Box 91030, Baton Rouge, LA 70821-9030. She is responsible for responding to all inquiries regarding this Emergency Rule. A copy of this Emergency Rule is available for review by interested parties at parish Medicaid offices.

Bruce D. Greenstein
Secretary

1210#080

DECLARATION OF EMERGENCY

Department of Health and Hospitals Bureau of Health Services Financing

Inpatient Hospital Services Major Teaching Hospitals Qualifying Criteria (LAC 50:V.1301-1309)

The Department of Health and Hospitals, Bureau of Health Services Financing proposes to adopt LAC 50:V.1301-1309 in the Medical Assistance Program as authorized by R.S. 36:254 and pursuant to Title XIX of the Social Security Act. This Emergency Rule is promulgated in accordance with the provisions of the Administrative Procedure Act, R.S. 49:953(B)(1) et seq., and shall be in effect for the maximum period allowed under the Act or until adoption of the final Rule, whichever occurs first.

The Department of Health and Hospitals, Office of the Secretary, Bureau of Health Services Financing adopted a Rule that established the reimbursement of major and minor teaching hospitals as peer groups under the prospective reimbursement methodology for hospitals (*Louisiana Register*, Volume 20, Number 6). The department amended the June 20, 1994 Rule to adopt new criteria for the reimbursement of graduate medical education (GME)

pursuant to Section 15 Schedule 09 of Act 19 of the 1998 Regular Session of the Louisiana Legislature and R.S. 39:71 et seq. (*Louisiana Register*, Volume 26, Number 3).

Act 347 of the 2009 Regular Session of the Louisiana Legislature revised the qualifying criteria for major teaching hospitals. In compliance with Act 347, the department promulgated an Emergency Rule which amended the provisions governing the qualifying criteria for major teaching hospitals. This Emergency Rule also repromulgated the March 20, 2000 Rule governing teaching hospitals in a codified format for inclusion in the *Louisiana Administrative Code* (*Louisiana Register*, Volume 36, Number 6). The department promulgated an Emergency Rule which amended the July 1, 2010 Emergency Rule to clarify the qualifying criteria for a major teaching hospital (*Louisiana Register*, Volume 37, Number 11). This Emergency Rule is being promulgated to continue the provisions of the November 20, 2011 Emergency Rule. This action is being taken to promote the health and welfare of Medicaid recipients by encouraging provider participation in the Medicaid Program so as to assure sufficient access to hospital services.

Effective November 17, 2012, the Department of Health and Hospitals, Bureau of Health Services Financing amends the provisions governing inpatient hospital services rendered by non-rural, non-state hospitals designated as teaching hospitals.

Title 50

PUBLIC HEALTH—MEDICAL ASSISTANCE

Part V. Hospital Services

Subpart 1. Inpatient Hospital Services

Chapter 13. Teaching Hospitals

Subchapter A. General Provisions

§1301. Major Teaching Hospitals

A. The Louisiana Medical Assistance Program's recognition of a major teaching hospital is limited to facilities having a documented affiliation agreement with a Louisiana medical school accredited by the Liaison Committee on Medical Education (LCME). A major teaching hospital shall meet one of the following criteria:

1. be a major participant in at least four approved medical residency programs and maintain an intern and resident full-time equivalency of at least 15 filled positions. At least two of the programs must be in medicine, surgery, obstetrics/gynecology, pediatrics, family practice, emergency medicine or psychiatry; or

2. maintain an intern and resident full-time equivalency of at least 20 filled positions with an approved medical residency program in family practice located more than 150 miles from the medical school accredited by the LCME.

B. For the purposes of recognition as a major teaching hospital, a facility shall be considered a "major participant" in a graduate medical education program if it meets the following criteria. The facility must:

1. pay for all of the costs of the training program in the non-hospital or hospital setting, including:

- a. the residents' salaries and fringe benefits;
- b. the portion of the cost of teaching physicians' salaries and fringe benefits attributable to direct graduate medical education; and
- c. other direct administrative costs of the program; and

2. participate in residency programs that:
 - a. require residents to rotate for a required experience;
 - b. require explicit approval by the appropriate Residency Review Committee (RRC) of the medical school with which the facility is affiliated prior to utilization of the facility; or
 - c. provide residency rotations of more than one sixth of the program length or more than a total of six months at the facility and are listed as part of an accredited program in the *Graduate Medical Education Directory* of the Accreditation Council for Graduate Medical Education (ACGME).

AUTHORITY NOTE: Promulgated in accordance with R.S. 36:254 and Title XIX of the Social Security Act.

HISTORICAL NOTE: Promulgated by the Department of Health and Hospitals, Bureau of Health Services Financing, LR 38:

§1303. Minor Teaching Hospitals

A. The Louisiana Medical Assistance Program's recognition of a minor teaching hospital is limited to facilities having a documented affiliation agreement with a Louisiana medical school accredited by the LCME. A minor teaching hospital shall meet the following criteria:

1. must participate significantly in at least one approved medical residency program in either medicine, surgery, obstetrics/gynecology, pediatrics, family practice, emergency medicine or psychiatry; and
2. maintain an intern and resident full time equivalency of at least six filled positions.

B. For the purposes of recognition as a minor teaching hospital, a facility is considered to "participate significantly" in a graduate medical education program if it meets the following criteria. The facility must:

1. pay for all of the costs of the training program in the non-hospital or hospital setting, including:
 - a. the residents' salaries and fringe benefits;
 - b. the portion of the cost of teaching physicians' salaries and fringe benefits attributable to direct graduate medical education; and
 - c. other direct administrative costs of the program;
 and

2. participate in residency programs that:
 - a. require residents to rotate for a required experience;
 - b. require explicit approval by the appropriate

Residency Review Committee of the medical school with which the facility is affiliated prior to utilization of the facility; or

- c. provide residency rotations of more than one sixth of the program length or more than a total of six months at the facility and are listed as part of an accredited program in the *Graduate Medical Education Directory* of the Accreditation Council for Graduate Medical Education.

i. If not listed, the sponsoring institution must have notified the ACGME, in writing, that the residents rotate through the facility and spend more than 1/6th of the program length or more than a total of six months at the facility.

AUTHORITY NOTE: Promulgated in accordance with R.S. 36:254 and Title XIX of the Social Security Act.

HISTORICAL NOTE: Promulgated by the Department of Health and Hospitals, Bureau of Health Services Financing, LR 38:

§1305. Approved Medical Residency Program

A. An approved medical residency program is one that meets one of the following criteria:

1. counts toward certification of the participant in a specialty or sub-specialty listed in the current edition of either *The Directory of Graduate Medical Education Programs* published by the American Medical Association, Department of Directories and Publications, or *The Annual Report and Reference Handbook* published by the American Board of Medical Specialties;
2. is approved by the ACGME as a fellowship program in geriatric medicine; or
3. is a program that would be accredited except for the accrediting agency's reliance upon an accreditation standard that requires an entity to perform an induced abortion or require, provide, or refer for training in the performance of induced abortions, or make arrangements for such training regardless of whether the standard provides exceptions or exemptions.

B. A residency program at a non-hospital facility may be counted by a hospital if:

1. there is a written agreement with the non-hospital facility that requires the hospital facility to pay for the cost of the training program; and
2. the agreement requires that the time that residents spend in the non-hospital setting is for patient care.

AUTHORITY NOTE: Promulgated in accordance with R.S. 36:254 and Title XIX of the Social Security Act.

HISTORICAL NOTE: Promulgated by the Department of Health and Hospitals, Bureau of Health Services Financing, LR 38:

§1307. Graduate Medical Education

A. The Bureau adopts criteria for the reimbursement of graduate medical education (GME) in facilities that do not qualify as major or minor teaching facilities. GME recognized by the Medical Assistance Program for reimbursement shall be limited to facilities having a documented affiliation agreement with a Louisiana medical school accredited by the LCME.

B. Payment for GME costs shall be limited to the direct cost of interns and residents in addition to the teaching physician supervisory costs. Teaching physician supervisory costs shall be limited in accordance with the provisions of the Medicare Provider Reimbursement Manual. The GME component of the rate shall be based on hospital specific graduate medical education Medicaid cost for the latest year on which hospital prospective reimbursements are rebased trended forward in accordance with the prospective reimbursement methodology for hospitals.

C. Hospitals implementing GME programs approved after the latest year on which hospital prospective reimbursements have been rebased shall have a GME component based on the first full cost reporting period that the approved GME program is in existence trended forward in accordance with the prospective reimbursement methodology for hospitals.

AUTHORITY NOTE: Promulgated in accordance with R.S. 36:254 and Title XIX of the Social Security Act.

HISTORICAL NOTE: Promulgated by the Department of Health and Hospitals, Bureau of Health Services Financing, LR 38:

§1309. Requirements for Reimbursement

A. Qualification for teaching hospital status or to receive reimbursement for GME costs shall be re-established at the beginning of each fiscal year.

B. To be reimbursed as a teaching hospital or to receive reimbursement for GME costs, a facility shall submit the following documentation to the Bureau of Health Services, Program Operations Section within 30 days of the beginning of each state fiscal year:

1. a copy of the executed affiliation agreement for the time period for which the teaching hospital status or GME reimbursement applies;

2. a copy of any agreements with non-hospital facilities; and

3. a signed Certification For Teaching Hospital Recognition.

C. Each hospital which is reimbursed as a teaching hospital or receives reimbursement for GME costs shall submit the following documentation to the Bureau of Health Services, Program Operations Section, within 90 days of the end of each state fiscal year:

1. a copy of the Intern and Resident Information

System report that is submitted annually to the Medicare intermediary; and

2. a copy of any notice given to the ACGME that residents rotate through a facility for more than one sixth of the program length or more than a total of six months.

D. Copies of all contracts, payroll records and time allocations related to graduate medical education must be maintained by the hospital and available for review by the state and federal agencies or their agents upon request.

E. No teaching hospital shall receive a per diem rate greater than 115 percent of its facility specific cost based on the latest rebasing year trended forward to the rate year in accordance with the prospective reimbursement methodology for hospitals.

F. The peer group maximum for minor teaching hospitals shall be the peer group maximum for minor teaching hospitals or the peer group maximum for peer group five, whichever is greater.

G. If it is subsequently discovered that a hospital has been reimbursed as a major or minor teaching hospital and did not qualify for that peer group for any reimbursement period, retroactive adjustment shall be made to reflect the correct peer group to which the facility should have been assigned. The resulting overpayment will be recovered through either immediate repayment by the hospital or recoupment from any funds due to the hospital from the department.

AUTHORITY NOTE: Promulgated in accordance with R.S. 36:254 and Title XIX of the Social Security Act.

HISTORICAL NOTE: Promulgated by the Department of Health and Hospitals, Bureau of Health Services Financing, LR 38:

Implementation of the provisions of this Rule may be contingent upon the approval of the U.S. Department of Health and Human Services, Centers for Medicare and Medicaid Services (CMS), if it is determined that submission to CMS for review and approval is required.

Interested persons may submit written comments to J. Ruth Kennedy, Bureau of Health Services Financing, P.O. Box 91030, Baton Rouge, LA 70821-9030. She is responsible for responding to all inquiries regarding this

Emergency Rule. A copy of this Emergency Rule is available for review by interested parties at parish Medicaid offices.

Bruce D. Greenstein
Secretary

1210#081

DECLARATION OF EMERGENCY

Department of Health and Hospitals Bureau of Health Services Financing

Inpatient Hospital Services—Non-Rural, Non-State Public Hospitals—Reimbursement Methodology (LAC 50:V.963)

The Department of Health and Hospitals, Bureau of Health Services Financing amends LAC 50:V. 963 in the Medical Assistance Program as authorized by R.S. 36:254 and pursuant to Title XIX of the Social Security Act. This Emergency Rule is promulgated in accordance with the provisions of the Administrative Procedure Act, R.S. 49:953(B)(1) et seq., and shall be in effect for the maximum period allowed under the Act or until adoption of the final Rule, whichever occurs first.

As a result of a budgetary shortfall in state fiscal year 2011, the Department of Health and Hospitals, Bureau of Health Services Financing amended the provisions governing the reimbursement methodology for inpatient hospital services to reduce the reimbursement rates for inpatient hospital services rendered by non-rural, non-state hospitals (*Louisiana Register*, Volume 37, Number 7).

The department now proposes to amend the provisions governing inpatient hospital services to provide supplemental Medicaid payments to qualifying non-rural, non-state public hospitals. This action is being taken to secure new federal funding and to promote the health and welfare of Medicaid recipients by ensuring sufficient provider participation in the Hospital Program. It is estimated that implementation of this Emergency Rule will increase expenditures in the Medicaid Program by approximately \$51,875,306 in state fiscal year 2012-13.

Effective October 1, 2012, the Department of Health and Hospitals, Bureau of Health Services Financing amends the provisions governing the reimbursement methodology for inpatient hospital services rendered by non-rural, non-state public hospitals.

Title 50

PUBLIC HEALTH—MEDICAL ASSISTANCE

Part V. Hospital Services

Subpart 1. Inpatient Hospital Services

Chapter 9. Non-Rural, Non-State Hospitals

Subchapter B. Reimbursement Methodology

§963. Public Hospitals

A.- D.2. ...

E. In the event that there is allowable non-state public upper payment limit that is not utilized, additional non-state public hospitals as defined by the department may be qualified for this payment.

AUTHORITY NOTE: Promulgated in accordance with R.S. 36:254 and Title XIX of the Social Security Act.

HISTORICAL NOTE: Promulgated by the Department of Health and Hospitals, Bureau of Health Services Financing, LR 38:

Implementation of the provisions of this Rule may be contingent upon the approval of the U.S. Department of Health and Human Services, Centers for Medicare and Medicaid Services (CMS), if it is determined that submission to CMS for review and approval is required.

Interested persons may submit written comments to J. Ruth Kennedy, Bureau of Health Services Financing, P.O. Box 91030, Baton Rouge, LA 70821-9030. She is responsible for responding to inquiries regarding this Emergency Rule. A copy of this Emergency Rule is available for review by interested parties at parish Medicaid offices.

Bruce D. Greenstein
Secretary

1210#013

DECLARATION OF EMERGENCY

Department of Health and Hospitals Bureau of Health Services Financing

Inpatient Hospital Services
Reimbursement Methodology
Medical Education Payments
(LAC 50:V.551, 967 and 1331)

The Department of Health and Hospitals, Bureau of Health Services Financing amends LAC 50:V.551, §967 and §1331 in the Medical Assistance Program as authorized by R.S. 36:254 and pursuant to Title XIX of the Social Security Act. This Emergency Rule is promulgated in accordance with the provisions of the Administrative Procedure Act, R.S. 49:953(B)(1) et seq., and shall be in effect for the maximum period allowed under the Act or until adoption of the final Rule, whichever occurs first.

The Department of Health and Hospitals, Bureau of Health Services Financing adopted provisions under the Medicaid State Plan to establish a coordinated system of care through an integrated network for the delivery of healthcare services to Medicaid recipients (*Louisiana Register*, Volume 37, Number 6). This delivery system, comprised of managed care organizations (MCOs), was implemented to improve performance and health care outcomes for Medicaid recipients. The per member per month reimbursements to MCOs do not include payments for medical education services rendered by participating hospitals.

Therefore, the department promulgated an Emergency Rule which amended the provisions governing the reimbursement methodology for inpatient hospital services which adopted provisions to continue medical education payments to state hospitals, children's specialty hospitals, and acute care hospitals classified as teaching hospitals when the hospitals are reimbursed by prepaid risk-bearing MCOs for inpatient hospital services (*Louisiana Register*, Volume 38, Number 2).

The Department of Health and Hospitals, Bureau of Health Services Financing promulgated an Emergency Rule which amended the February 1, 2012 Emergency Rule to

clarify the provisions governing the reimbursement methodology for inpatient hospital services (*Louisiana Register*, Volume 38, Number 3). This Emergency Rule is being promulgated to continue the provisions of the March 20, 2012 Emergency Rule. This action is being taken to promote the health and welfare of Medicaid recipients by ensuring sufficient provider participation and recipient access to services.

Effective November 17, 2012, the Department of Health and Hospitals, Bureau of Health Services Financing amends the provisions governing the reimbursement methodology for inpatient hospital services.

Title 50

PUBLIC HEALTH-MEDICAL ASSISTANCE

Part V. Hospital Services

Subpart 1. Inpatient Hospital Services

Chapter 5. State Hospitals

Subchapter B. Reimbursement Methodology

§551. Acute Care Hospitals

A. - D. ...

E. Effective for dates of service on or after February 1, 2012, medical education payments for inpatient services which are reimbursed by a prepaid risk-bearing managed care organization (MCO) shall be paid monthly by Medicaid as interim lump sum payments.

1. Hospitals with qualifying medical education programs shall submit a listing of inpatient claims paid each month by each MCO.

a. Qualifying medical education programs are defined as graduate medical education, paramedical education, and nursing schools.

2. Monthly payments shall be calculated by multiplying the number of qualifying inpatient days times the medical education costs included in each state hospital's interim per diem rate as calculated per the latest filed Medicaid cost report.

3. Final payment shall be determined based on the actual MCO covered days and allowable inpatient Medicaid medical education costs for the cost reporting period per the Medicaid cost report.

AUTHORITY NOTE: Promulgated in accordance with R.S. 36:254 and Title XIX of the Social Security Act.

HISTORICAL NOTE: Promulgated by the Department of Health and Hospitals, Bureau of Health Services Financing, LR 38:

Chapter 9. Non-Rural, Non-State Hospitals

Subchapter B. Reimbursement Methodology

§967. Children's Specialty Hospitals

A. - H. ...

I. Effective for dates of service on or after February 1, 2012, medical education payments for inpatient services which are reimbursed by a prepaid risk-bearing managed care organization (MCO) shall be paid by Medicaid monthly as interim lump sum payments.

1. Hospitals with qualifying medical education programs shall submit a listing of inpatient claims paid each month by each MCO.

a. Qualifying medical education programs are defined as graduate medical education, paramedical education, and nursing schools.

2. Monthly payments shall be calculated by multiplying the number of qualifying inpatient days times the medical education costs included in each children's

specialty hospital's interim per diem rate as calculated per the latest filed Medicaid cost report.

3. Final payment shall be determined based on the actual MCO covered days and medical education costs for the cost reporting period per the Medicaid cost report. Reimbursement shall be at the same percentage that is reimbursed for fee-for-service covered Medicaid costs after application of reimbursement caps as specified in §967.A.-C and reductions specified in §967.F.-H.

AUTHORITY NOTE: Promulgated in accordance with R.S. 36:254 and Title XIX of the Social Security Act.

HISTORICAL NOTE: Promulgated by the Department of Health and Hospitals, Bureau of Health Services Financing, LR 36:2562 (November 2010), LR 37:2162 (July 2011), LR 38:

Chapter 13. Teaching Hospitals
Subchapter B. Reimbursement Methodology
§1331. Acute Care Hospitals

A. - E. ...

F. Effective for dates of service on or after February 1, 2012, medical education payments for inpatient services which are reimbursed by a prepaid risk-bearing managed care organization (MCO) shall be paid monthly by Medicaid as interim lump sum payments.

1. Hospitals with qualifying medical education programs shall submit a listing of inpatient claims paid each month by each MCO.

a. Qualifying medical education programs are defined as graduate medical education, paramedical education, and nursing schools.

2. Qualifying hospitals must have a direct medical education add-on component included in their prospective Medicaid per diem rates as of January 31, 2012 which was carved-out of the per diem rate reported to the MCOs.

3. Monthly payments shall be calculated by multiplying the number of qualifying inpatient days submitted by the medical education costs component included in each hospital's fee-for-service prospective per diem rate. Monthly payment amounts shall be verified by the Department semi-annually using reports of MCO covered days generated from encounter data. Payment adjustments or recoupments shall be made as necessary based on the MCO encounter data reported to the department.

AUTHORITY NOTE: Promulgated in accordance with R.S. 36:254 and Title XIX of the Social Security Act.

HISTORICAL NOTE: Promulgated by the Department of Health and Hospitals, Bureau of Health Services Financing, LR 34:877 (May 2008), LR 38:

Implementation of the provisions of this Rule may be contingent upon the approval of the U.S. Department of Health and Human Services, Centers for Medicare and Medicaid Services (CMS) if it is determined that submission to CMS for review and approval is required.

Interested persons may submit written comments to J. Ruth Kennedy, Bureau of Health Services Financing, P.O. Box 91030, Baton Rouge, LA 70821-9030. She is responsible for responding to inquiries regarding this Emergency Rule. A copy of this Emergency Rule is available for review by interested parties at parish Medicaid offices.

Bruce D. Greenstein
Secretary

1210#082

DECLARATION OF EMERGENCY

Department of Health and Hospitals Bureau of Health Services Financing

Intermediate Care Facilities for Persons
with Developmental Disabilities
Reimbursement Rate Reduction
(LAC 50:VII.32903)

The Department of Health and Hospitals, Bureau of Health Services Financing amends LAC 50:VII.32903 in the Medical Assistance Program as authorized by R.S. 36:254 and pursuant to Title XIX of the Social Security Act and as directed by House Bill 1 of the 2012 Regular Session of the Louisiana Legislature which states: "The secretary is directed to utilize various cost containment measures to ensure expenditures remain at the level appropriated in this Schedule, including but not limited to precertification, preadmission screening, diversion, fraud control, utilization review and management, prior authorization, service limitations, drug therapy management, disease management, cost sharing, and other measures as permitted under federal law." This Emergency Rule is promulgated in accordance with the provisions of the Administrative Procedure Act, R.S. 49:953(B)(1) et seq., and shall be in effect for the maximum period allowed under the Act or until adoption of the final Rule, whichever occurs first.

As a result of a budgetary shortfall in state fiscal year 2011, the Department of Health and Hospitals, Bureau of Health Services Financing amended the provisions governing the reimbursement methodology for non-state ICFs/DD to reduce the per diem rates (*Louisiana Register*, Volume 37, Number 10).

Due to a budgetary shortfall in state fiscal year 2013, the department promulgated an Emergency Rule which amended the provisions governing the reimbursement methodology for non-state ICFs/DD to further reduce the per diem rates (*Louisiana Register*, Volume 38, Number 7). This Emergency Rule is being promulgated to continue the provisions of the July 1, 2012 Emergency Rule. This action is being taken to avoid a budget deficit in the medical assistance programs.

Taking the proposed per diem rate reduction into consideration, the department has carefully reviewed the proposed rates and is satisfied that they are consistent with efficiency, economy and quality of care and are sufficient to enlist enough providers so that private (non-state) intermediate care facility services for persons with developmental disabilities under the State Plan are available at least to the extent that they are available to the general population in the state.

Effective October 30, 2012, the Department of Health and Hospitals, Bureau of Health Services Financing amends the provisions governing the reimbursement methodology for intermediate care facilities for persons with developmental disabilities to reduce the per diem rates.

Title 50
PUBLIC HEALTH—MEDICAL ASSISTANCE
Part VII. Long Term Care
Subpart 3. Intermediate Care Facilities for Persons with
Developmental Disabilities
Chapter 329. Reimbursement Methodology
Subchapter A. Non-State Facilities
§32903. Rate Determination

A. - L. ...

M. Effective for dates of service on or after July 1, 2012, the per diem rates for non-state intermediate care facilities for persons with developmental disabilities (ICFs/DD) shall be reduced by 1.5 percent of the per diem rates on file as of June 30, 2012.

AUTHORITY NOTE: Promulgated in accordance with R.S. 36:254 and Title XIX of the Social Security Act.

HISTORICAL NOTE: Promulgated by the Department of Health and Hospitals, Office of the Secretary, Bureau of Health Services Financing, LR 31:2253 (September 2005), amended LR 33:462 (March 2007), LR 33:2202 (October 2007), amended by the Department of Health and Hospitals, Bureau of Health Services Financing, LR 36:1555 (July 2010), amended LR 37:3028 (October 2011), LR 38:

Implementation of the provisions of this Rule may be contingent upon the approval of the U.S. Department of Health and Human Services, Centers for Medicare and Medicaid Services (CMS), if it is determined that submission to CMS for review and approval is required.

Interested persons may submit written comments to J. Ruth Kennedy, Bureau of Health Services Financing, P.O. Box 91030, Baton Rouge, LA 70821-9030. She is responsible for responding to inquiries regarding this Emergency Rule. A copy of this Emergency Rule is available for review by interested parties at parish Medicaid offices.

Bruce D. Greenstein
Secretary

1210#083

DECLARATION OF EMERGENCY

Department of Health and Hospitals
Bureau of Health Services Financing

Laboratory and Radiology Services
Reimbursement Rate Reduction
(LAC 50:XIX.4329 and 4334-4337)

The Department of Health and Hospitals, Bureau of Health Services Financing amends LAC 50: XIX.4329 and §§4334-4337 in the Medical Assistance Program as authorized by R.S. 36:254 and pursuant to Title XIX of the Social Security Act and as directed by House Bill 1 of the 2012 Regular Session of the Louisiana Legislature which states: "The secretary is directed to utilize various cost containment measures to ensure expenditures remain at the level appropriated in this Schedule, including but not limited to precertification, preadmission screening, diversion, fraud control, utilization review and management, prior authorization, service limitations, drug therapy management, disease management, cost sharing, and other measures as permitted under federal law." This Emergency Rule is promulgated in accordance with the provisions of the Administrative Procedure Act, R. S. 49:953(B)(1) et seq.,

and shall be in effect for the maximum period allowed under the Act or until adoption of the final Rule, whichever occurs first.

As a result of a budgetary shortfall in state fiscal year 2011, the Department of Health and Hospitals, Bureau of Health Services Financing amended the provisions governing the reimbursement methodology for laboratory and radiology services to reduce the reimbursement rates (*Louisiana Register*, Volume 37, Number 10).

Due to a budgetary shortfall in state fiscal year 2013, the department promulgated an Emergency Rule which amended the provisions governing the reimbursement methodology for laboratory and radiology services to reduce the reimbursement rates (*Louisiana Register*, Volume 38, Number 7). This Emergency Rule is being promulgated to continue the provisions of the July 1, 2012 Emergency Rule. This action is being taken to avoid a budget deficit in the medical assistance programs.

Effective October 30, 2012, the Department of Health and Hospitals, Bureau of Health Services Financing amends the provisions governing the reimbursement methodology for laboratory and radiology services to reduce the reimbursement rates.

Title 50
PUBLIC HEALTH—MEDICAL ASSISTANCE
Part XIX. Other Services
Subpart 3. Laboratory and X-Ray
Chapter 43. Billing and Reimbursement
§4329. Laboratory Services (Physicians and
Independent Laboratories)

A. - J. ...

K. Effective for dates of service on or after July 1, 2012, the reimbursement rates for laboratory services shall be reduced by 3.7 percent of the fee amounts on file as of June 30, 2012.

AUTHORITY NOTE: Promulgated in accordance with R.S. 46:153, R.S. 49:1008(A), P.L. 98-369, and Title XIX of the Social Security Act.

HISTORICAL NOTE: Promulgated by the Department of Health and Hospitals, Office of the Secretary, Bureau of Health Services Financing, LR 28:1025 (May 2002), amended by the Department of Health and Hospitals, Bureau of Health Services Financing, LR 35:1897 (September 2009), LR 36:1248 (June 2010), LR 36:2563 (November 2010), LR 37:3028 (October 2011), LR 38:

§4334. Radiology Services

A. - I. ...

J. Effective for dates of service on or after July 1, 2012, the reimbursement rates for radiology services shall be reduced by 3.7 percent of the fee amounts on file as of June 30, 2012.

AUTHORITY NOTE: Promulgated in accordance with R.S. 36:254 and Title XIX of the Social Security Act.

HISTORICAL NOTE: Promulgated by the Department of Health and Hospitals, Bureau of Health Services Financing, LR 35:1897 (September 2009), amended LR 36:1248 (June 2010), LR 36:2563 (November 2010), LR 37:3029 (October 2011), LR 38:

§4335. Portable Radiology Services

A. - G. ...

H. Effective for dates of service on or after July 1, 2012, the reimbursement rates for portable radiology services shall be reduced by 3.7 percent of the fee amounts on file as of June 30, 2012.

AUTHORITY NOTE: Promulgated in accordance with R.S. 36:254 and Title XIX of the Social Security Act.

HISTORICAL NOTE: Promulgated by the Department of Health and Hospitals, Office of the Secretary, Bureau of Health Services Financing, LR 30:1026 (May 2004), amended by the Department of Health and Hospitals, Bureau of Health Services Financing, LR 35:1898 (September 2009), LR 36:1248 (June 2010), LR 36:2563 (November 2010), LR 37:3029 (October 2011), LR 38:

§4337. Radiation Therapy Centers

A. - G. ...

H. Effective for dates of service on or after July 1, 2012, the reimbursement rates for radiology services provided by radiation therapy centers shall be reduced by 3.7 percent of the fee amounts on file as of June 30, 2012.

AUTHORITY NOTE: Promulgated in accordance with R.S. 36:254 and Title XIX of the Social Security Act.

HISTORICAL NOTE: Promulgated by the Department of Health and Hospitals, Bureau of Health Services Financing, LR 35:1898 (September 2009), amended LR 36:1248 (June 2010), LR 36:2563 (November 2010), LR 37:3029 (October 2011), LR 38:

Implementation of the provisions of this Rule may be contingent upon the approval of the U.S. Department of Health and Human Services, Centers for Medicare and Medicaid Services (CMS), if it is determined that submission to CMS for review and approval is required.

Interested persons may submit written comments to J. Ruth Kennedy, Bureau of Health Services Financing, P.O. Box 91030, Baton Rouge, LA 70821-9030. She is responsible for responding to inquiries regarding this Emergency Rule. A copy of this Emergency Rule is available for review by interested parties at parish Medicaid offices.

Bruce D. Greenstein
Secretary

1210#084

DECLARATION OF EMERGENCY

Department of Health and Hospitals Bureau of Health Services Financing

LaCHIP Affordable Plan—Dental Program Reimbursement Rate Reduction (LAC 50:III.20509)

The Department of Health and Hospitals, Bureau of Health Services Financing adopts LAC 50:III.20509 in the Medical Assistance Program as authorized by R.S. 36:254 and pursuant to Title XIX of the Social Security Act and as directed by House Bill 1 of the 2012 Regular Session of the Louisiana Legislature which states: "The secretary is directed to utilize various cost containment measures to ensure expenditures remain at the level appropriated in this Schedule, including but not limited to precertification, preadmission screening, diversion, fraud control, utilization review and management, prior authorization, service limitations, drug therapy management, disease management, cost sharing, and other measures as permitted under federal law." This Emergency Rule is promulgated in accordance with the provisions of the Administrative Procedure Act, R.S. 49:953(B)(1) et seq., and shall be in effect for the maximum period allowed under the Act or until adoption of the final Rule, whichever occurs first.

The Department of Health and Hospitals, Bureau of Health Services Financing adopted provisions to implement phase five of LaCHIP as a stand-alone program under Title XXI provisions to provide coverage to uninsured children whose family income is from 200 percent up to 250 percent of the FPL (*Louisiana Register*, Volume 34, Number 4).

Due to a budgetary shortfall in state fiscal year 2013, the department promulgated an Emergency Rule which adopted provisions governing the reimbursement methodology for the LaCHIP Affordable Plan Dental Program in order to reduce the reimbursement rates (*Louisiana Register*, Volume 38, Number 7). This Emergency Rule is being promulgated to continue the provisions of the July 1, 2012 Emergency Rule. This action is being taken to avoid a budget deficit in the medical assistance programs.

Effective October 30, 2012, the Department of Health and Hospitals, Bureau of Health Services Financing adopts provisions governing the reimbursement methodology for the LaCHIP Affordable Plan Dental Program to reduce the reimbursement rates.

Title 50

PUBLIC HEALTH—MEDICAL ASSISTANCE

Part III. Eligibility

Subpart 11. State Children's Health Insurance Program Chapter 205. Louisiana Children's Health Insurance Program (LaCHIP) - Phase V

§20509. Dental Services Reimbursement Methodology

A. Services covered in the LaCHIP Affordable Plan Dental Program shall be reimbursed at the lower of either:

1. the dentist's billed charges minus any third party coverage; or
2. the state's established schedule of fees, which is developed in consultation with the Louisiana Dental Association and the Medicaid dental consultants, minus any third party coverage.

B. Effective for dates of service on or after July 1, 2012, the reimbursement fees for LaCHIP Affordable Plan dental services shall be reduced to the following percentages of the 2009 National Dental Advisory Service Comprehensive Fee Report 70th percentile, unless otherwise stated in this Chapter:

1. 65 percent for the following oral evaluation services:
 - a. periodic oral examination;
 - b. oral examination-patients under 3 years of age;and
 - c. comprehensive oral examination-new patients;
2. 62 percent for the following annual and periodic diagnostic and preventive services:
 - a. radiographs-periapical, first film;
 - b. radiographs-periapical, each additional film;
 - c. radiographs-panoramic film;
 - d. diagnostic casts;
 - e. prophylaxis-adult and child;
 - f. topical application of fluoride, adult and child (prophylaxis not included); and
 - g. topical fluoride varnish, therapeutic application for moderate to high caries risk patients (under 6 years of age);

3. 45 percent for the following diagnostic and adjunctive general services:
 - a. oral/facial image;
 - b. non-intravenous conscious sedation; and
 - c. hospital call; and
4. 56 percent for the remainder of the dental services.

C. Removable prosthodontics and orthodontic services are excluded from the July 1, 2012 rate reduction.

AUTHORITY NOTE: Promulgated in accordance with R.S. 36:254 and Title XXI of the Social Security Act.

HISTORICAL NOTE: Promulgated by the Department of Health and Hospitals, Bureau of Health Services Financing, LR 38:

Implementation of the provisions of this Rule may be contingent upon the approval of the U.S. Department of Health and Human Services, Centers for Medicare and Medicaid Services (CMS), if it is determined that submission to CMS for review and approval is required.

Interested persons may submit written comments to J. Ruth Kennedy, Bureau of Health Services Financing, P.O. Box 91030, Baton Rouge, LA 70821-9030. She is responsible for responding to inquiries regarding this Emergency Rule. A copy of this Emergency Rule is available for review by interested parties at parish Medicaid offices.

Bruce D. Greenstein
Secretary

1210#085

DECLARATION OF EMERGENCY

Department of Health and Hospitals Bureau of Health Services Financing

Medical Transportation Program
Emergency Ambulance Services
Reimbursement Rate Reduction
(LAC 50:XXVII.325 and 353)

The Department of Health and Hospitals, Bureau of Health Services Financing amends LAC 50:XXVII.325 and §353 in the Medical Assistance Program as authorized by R.S. 36:254 and pursuant to Title XIX of the Social Security Act and as directed by House Bill 1 of the 2012 Regular Session of the Louisiana Legislature which states: "The secretary is directed to utilize various cost containment measures to ensure expenditures remain at the level appropriated in this Schedule, including but not limited to precertification, preadmission screening, diversion, fraud control, utilization review and management, prior authorization, service limitations, drug therapy management, disease management, cost sharing, and other measures as permitted under federal law." This Emergency Rule is promulgated in accordance with the provisions of the Administrative Procedure Act, R.S. 49:953(B)(1) et seq., and shall be in effect for the maximum period allowed under the Act or until adoption of the final Rule, whichever occurs first.

As a result of a budgetary shortfall in state fiscal year 2011, the Department of Health and Hospitals, Bureau of Health Services Financing amended the provisions governing the reimbursement methodology for emergency medical transportation services to reduce the reimbursement rates (*Louisiana Register*, Volume 37, Number 10).

As a result of a budgetary shortfall in state fiscal year 2013, the department promulgated an Emergency Rule which amended the provisions governing the reimbursement methodology for emergency medical transportation services to reduce the reimbursement rates (*Louisiana Register*, Volume 38, Number 7). This Emergency Rule is being promulgated to continue the provisions of the July 1, 2012 Emergency Rule. This action is being taken to avoid a budget deficit in the medical assistance programs.

Effective October 30, 2012, the Department of Health and Hospitals, Bureau of Health Services Financing amends the provisions governing the reimbursement methodology for emergency medical transportation services to reduce the reimbursement rates.

Title 50

PUBLIC HEALTH—MEDICAL ASSISTANCE

Part XXVII. Medical Transportation Program

Chapter 3. Emergency Medical Transportation

Subchapter B. Ground Transportation

§325. Reimbursement

A. - H. ...

I. Effective for dates of service on or after July 1, 2012, the reimbursement rates for emergency ambulance transportation services shall be reduced by 5.25 percent of the rate on file as of June 30, 2012.

AUTHORITY NOTE: Promulgated in accordance with R.S. 36:254 and Title XIX of the Social Security Act.

HISTORICAL NOTE: Promulgated by the Department of Health and Hospitals, Office of the Secretary, Bureau of Health Services Financing, LR 34:878 (May 2008), amended by the Department of Health and Hospitals, Bureau of Health Services Financing, LR 36:1248 (June 2010), amended LR 36:2564 (November 2010), amended LR 37:3029 (October 2011), LR 38:

Subchapter C. Aircraft Transportation

§353. Reimbursement

A. - F. ...

G. Effective for dates of service on or after July 1, 2012, the reimbursement rates for fixed winged and rotor winged emergency air ambulance services shall be reduced by 5.25 percent of the rate on file as of June 30, 2012.

AUTHORITY NOTE: Promulgated in accordance with R.S. 36:254 and Title XIX of the Social Security Act.

HISTORICAL NOTE: Promulgated by the Department of Health and Hospitals, Office of the Secretary, Bureau of Health Services Financing, LR 35:70 (January 2009), amended by the Department of Health and Hospitals, Bureau of Health Services Financing, LR 36:2594 (November 2010), amended LR 37:3029 (October 2011), LR 38:

Implementation of the provisions of this Rule may be contingent upon the approval of the U.S. Department of Health and Human Services, Centers for Medicare and Medicaid Services (CMS), if it is determined that submission to CMS for review and approval is required.

Interested persons may submit written comments to J. Ruth Kennedy, Bureau of Health Services Financing, P.O. Box 91030, Baton Rouge, LA 70821-9030. She is responsible for responding to inquiries regarding this Emergency Rule. A copy of this Emergency Rule is available for review by interested parties at parish Medicaid offices.

Bruce D. Greenstein
Secretary

1210#086

DECLARATION OF EMERGENCY

Department of Health and Hospitals Bureau of Health Services Financing

Medical Transportation Program
Emergency Ambulance Services
Supplemental Payments
(LAC 50:XXVII.327 and 355)

The Department of Health and Hospitals, Bureau of Health Services Financing amends LAC 50:XXVII.327 and §355 in the Medical Assistance Program as authorized by R.S. 36:254 and pursuant to Title XIX of the Social Security Act. This Emergency Rule is promulgated in accordance with the provisions of the Administrative Procedure Act, R.S. 49:953(B)(1) et seq., and shall be in effect for the maximum period allowed under the Act or until adoption of the final Rule, whichever occurs first.

The Department of Health and Hospitals, Bureau of Health Services Financing provides reimbursement for emergency ambulance transportation services. The department promulgated an Emergency Rule which established supplemental payments for governmental ambulance providers who render emergency medical transportation services to low income and needy patients in the state of Louisiana (*Louisiana Register*, Volume 37, Number 6). The department promulgated an Emergency Rule which amended the provisions of the July 1, 2011 Emergency Rule to allow supplemental payments for all ambulance providers who render emergency medical transportation services to low income and needy patients (*Louisiana Register*, Volume 37, Number 7). The July 20, 2011 Emergency Rule was amended to allow supplemental payments to providers of air ambulance transportation services (*Louisiana Register*, Volume 37, Number 8). The department promulgated an Emergency Rule which rescinded and replaced the July 1, 2011, the July 20, 2011, and the August 20, 2011 Emergency Rules in order to promulgate clear and concise provisions governing supplemental payments for emergency ambulance services (*Louisiana Register*, Volume 37, Number 9). The department promulgated an Emergency Rule which amended the September 20, 2011 Emergency Rule to clarify the provisions governing supplemental payments for emergency ambulance services (*Louisiana Register*, Volume 37, Number 12). The department promulgated an Emergency Rule which amended the December 20, 2011 Emergency Rule to further clarify the provisions governing supplemental payments for emergency ambulance services (*Louisiana Register*, Volume 38, Number 3). This Emergency Rule is being promulgated to continue the provisions of the March 20, 2012 Emergency Rule. This action is being taken to promote the health and welfare of Medicaid recipients by ensuring continued access to emergency ambulance services.

Effective November 17, 2012, the Department of Health and Hospitals, Bureau of Health Services Financing amends the provisions governing supplemental payments for emergency medical transportation services rendered by ambulance providers.

Title 50

PUBLIC HEALTH—MEDICAL ASSISTANCE Part XXVII. Medical Transportation Program Chapter 3. Emergency Medical Transportation Subchapter B. Ground Transportation §327. Supplemental Payments for Ambulance Providers

A. Effective for dates of service on or after September 20, 2011, quarterly supplemental payments shall be issued to qualifying ambulance providers for emergency medical transportation services rendered during the quarter.

B. Qualifying Criteria. Ambulance service providers must meet the following requirements in order to qualify to receive supplemental payments. The ambulance service provider must be:

1. licensed by the state of Louisiana;
2. enrolled as a Louisiana Medicaid provider;
3. provider of emergency medical transportation or air ambulance services pursuant to 42 CFR 440.170; and
4. be affiliated with the Statewide Ambulance Service District.

C. Payment Methodology. The supplemental payment to each qualifying ambulance service provider will not exceed the sum of:

1. the difference between the Medicaid payments otherwise made to these qualifying providers for emergency medical transportation and air ambulance services and the average amount that would have been paid at the equivalent community rate; and
2. the difference between the payments made to these qualifying providers for emergency medical transportation and air ambulance services provided to uninsured patients and the average amount that would have been paid at the equivalent community rate.

D. The supplemental payment will be determined in a manner to bring payments for these services up to the community rate level. The community rate is defined as the average amount payable by commercial insurers for the same services.

E. Supplemental Payment Calculation. The following methodology shall be used to establish the quarterly supplemental payment for ambulance providers:

1. The department shall identify Medicaid ambulance service providers that were qualified to receive supplemental Medicaid reimbursement for emergency medical transportation services and air ambulance services during the quarter.

2. For each Medicaid ambulance service provider described in E.1, the department shall identify the emergency medical transportation and air ambulance services for which the Medicaid ambulance service providers were eligible to be reimbursed.

3. For each Medicaid ambulance service provider described in E.1, the department shall calculate the reimbursement paid to the Medicaid ambulance service providers for the emergency medical transportation and air ambulance services identified under E.2.

4. For each Medicaid ambulance service provider described in E.1, the department shall calculate the Medicaid ambulance service provider's equivalent community rate for

each of the Medicaid ambulance service provider's services identified under E.2.

5. For each Medicaid ambulance service provider described in E.1, the department shall subtract an amount equal to the reimbursement calculation for each of the emergency medical transportation and air ambulance services under E.3 from an amount equal to the amount calculated for each of the emergency medical transportation and air ambulance services under E.4.

6. For each Medicaid ambulance service provider described in E.1, the department shall calculate the sum of each of the amounts calculated for emergency medical transportation and air ambulance services under E.5.

7. For each Medicaid ambulance service provider described in E.1, the department shall calculate each emergency ambulance service provider's upper payment limit by totaling the provider's total Medicaid payment differential from E.6.

8. The department will reimburse providers based on the following criteria:

a. For ambulance service providers identified in E.1 located in large urban areas and owned by governmental entities, reimbursement will be up to 130 percent of the provider's average commercial rate calculated in E.7. Aggregate payment will never exceed the maximum as defined in H. below.

b. For all other ambulance service providers identified in E.1 reimbursement will be up to 80 percent of the provider's average commercial rate calculated in E.7.

9. - 17. Repealed.

F. Calculation of Average Commercial Rate. The supplemental payment will be determined in a manner to bring payments for these services up to the average commercial rate level.

1. For purposes of these provisions, the average community rate level is defined as the average amount payable by the commercial payers for the same services.

2. The state will align the paid Medicaid claims with the Medicare fees for each HCPCS or CPT code for the ambulance provider and calculate the Medicare payment for those claims. The state will then calculate an overall Medicare to commercial conversion factor for each ambulance provider by dividing the total amount of the average commercial payments for the claims by the total Medicare payments for the claims. The commercial to Medicare ratio for each provider will be re-determined at least every three years.

G. The supplemental payment will be made effective for emergency medical transportation provided on or after September 20, 2011. This payment is based on the average amount that would have been paid at the equivalent community rate. After the initial calculation for fiscal year 2011-2012, the department will rebase the equivalent community rate using adjudicated claims data for services from the most recently completed fiscal year. This calculation may be made annually, but shall be made no less than every three years.

H. The total amount to be paid by the state to qualified Medicaid ambulance service providers for supplemental Medicaid payments shall not exceed the total of the Medicaid payment differentials calculated under §327.E.6 for all qualified Medicaid ambulance service providers.

AUTHORITY NOTE: Promulgated in accordance with R.S. 36:254 and Title XIX of the Social Security Act.

HISTORICAL NOTE: Promulgated by the Department of Health and Hospitals, Bureau of Health Services Financing, LR 38:

Subchapter C. Air Transportation

§355. Supplemental Payments for Ambulance Providers

A. Effective for dates of service on or after September 20, 2011, quarterly supplemental payments shall be issued to qualifying ambulance providers for emergency medical air transportation services rendered during the quarter.

B. Qualifying Criteria. Ambulance service providers must meet the following requirements in order to qualify to receive supplemental payments. The ambulance service provider must be:

1. licensed by the state of Louisiana;
2. enrolled as a Louisiana Medicaid provider;
3. provider of emergency medical transportation or air ambulance services pursuant to 42 CFR 440.170; and
4. be affiliated with the Statewide Ambulance Service District.

C. Payment Methodology. The supplemental payment to each qualifying ambulance service provider will not exceed the sum of:

1. the difference between the Medicaid payments otherwise made to these qualifying providers for emergency medical transportation and air ambulance services and the average amount that would have been paid at the equivalent community rate; and

2. the difference between the payments made to these qualifying providers for emergency medical transportation and air ambulance services provided to uninsured patients and the average amount that would have been paid at the equivalent community rate.

D. The supplemental payment will be determined in a manner to bring payments for these services up to the community rate level. The community rate is defined as the average amount payable by commercial insurers for the same services.

E. Supplemental Payment Calculation. The following methodology shall be used to establish the quarterly supplemental payment for ambulance providers:

1. The department shall identify Medicaid ambulance service providers that were qualified to receive supplemental Medicaid reimbursement for emergency medical transportation services and air ambulance services during the quarter.

2. For each Medicaid ambulance service provider described in E.1, the department shall identify the emergency medical transportation and air ambulance services for which the Medicaid ambulance service providers were eligible to be reimbursed.

3. For each Medicaid ambulance service provider described in E.1, the department shall calculate the reimbursement paid to the Medicaid ambulance service providers for the emergency medical transportation and air ambulance services identified under E.2.

4. For each Medicaid ambulance service provider described in E.1, the department shall calculate the Medicaid ambulance service provider's equivalent community rate for each of the Medicaid ambulance service provider's services identified under E.2.

5. For each Medicaid ambulance service provider described in E.1, the department shall subtract an amount equal to the reimbursement calculation for each of the emergency medical transportation and air ambulance services under E.3 from an amount equal to the amount calculated for each of the emergency medical transportation and air ambulance services under E.4.

6. For each Medicaid ambulance service provider described in E.1, the department shall calculate the sum of each of the amounts calculated for emergency medical transportation and air ambulance services under E.5.

7. For each Medicaid ambulance service provider described in E.1, the Department shall calculate each emergency ambulance service provider's upper payment limit by totaling the provider's total Medicaid payment differential from B.6.

8. The department will reimburse providers based on the following criteria:

a. For ambulance service providers identified in E.1. located in large urban areas and owned by governmental entities, reimbursement will be up to 130% of the provider's average commercial rate calculated in E.7. Aggregate payment will never exceed the maximum as defined in Section H.

b. For all other ambulance service providers identified in E.1. reimbursement will be up to 80% of the provider's average commercial rate calculated in E.7.

9. - 17. Repealed.

F. Calculation of Average Commercial Rate. The supplemental payment will be determined in a manner to bring payments for these services up to the average commercial rate level.

1. For purposes of these provisions, the average commercial rate level is defined as the average amount payable by the commercial payers for the same services.

2. The state will align the paid Medicaid claims with the Medicare fees for each HCPCS or CPT code for the ambulance provider and calculate the Medicare payment for those claims. The state will then calculate an overall Medicare to commercial conversion factor for each ambulance provider by dividing the total amount of the average commercial payments for the claims by the total Medicare payments for the claims. The commercial to Medicare ratio for each provider will be re-determined at least every three years.

G. The supplemental payment will be made effective for air ambulance services provided on or after September 20, 2011. This payment is based on the average amount that would have been paid at the equivalent community rate. After the initial calculation for fiscal year 2011-2012, the department will rebase the equivalent community rate using adjudicated claims data for services from the most recently completed fiscal year. This calculation may be made annually, but shall not be made less often than every three years.

H. The total amount to be paid by the state to qualified Medicaid ambulance service providers for supplemental Medicaid payments shall not exceed the total of the Medicaid payment differentials calculated under §327.E.6 for all qualified Medicaid ambulance service providers.

AUTHORITY NOTE: Promulgated in accordance with R.S. 36:254 and Title XIX of the Social Security Act.

HISTORICAL NOTE: Promulgated by the Department of Health and Hospitals, Bureau of Health Services Financing, LR 38:

Implementation of the provisions of this Rule may be contingent upon the approval of the U.S. Department of Health and Human Services, Centers for Medicare and Medicaid Services (CMS), if it is determined that submission to CMS for review and approval is required.

Interested persons may submit written comments to J. Ruth Kennedy, Bureau of Health Services Financing, P.O. Box 91030, Baton Rouge, LA 70821-9030. She is responsible for responding to inquiries regarding this Emergency Rule. A copy of this Emergency Rule is available for review by interested parties at parish Medicaid offices.

Bruce D. Greenstein
Secretary

1210#087

DECLARATION OF EMERGENCY

Department of Health and Hospitals Bureau of Health Services Financing

Nursing Facilities
Reimbursement Methodology
Low Income and Needy Care Collaboration
(LAC 50:II.20023)

The Department of Health and Hospitals, Bureau of Health Services Financing adopts LAC 50:II.20023 in the Medical Assistance Program as authorized by R.S. 36:254 and pursuant to Title XIX of the Social Security Act. This Emergency Rule is promulgated in accordance with the provisions of the Administrative Procedure Act, R.S. 49:953(B)(1) et seq., and shall be in effect for the maximum period allowed under the Act or until adoption if the final Rule, whichever occurs first.

The Department of Health and Hospitals, Bureau of Health Services Financing promulgated an Emergency Rule which amended the provisions governing the reimbursement methodology for nursing facilities to adopt provisions to establish a supplemental Medicaid payment for nursing facilities who enter into an agreement with a state or local governmental entity for the purpose of providing health care services to low income and needy patients (*Louisiana Register*, Volume 37, Number 11). This Emergency Rule is being promulgated to continue the provisions of the November 1, 2011 Emergency Rule. This action is being taken to secure new federal funding and to promote the public health and welfare of Medicaid recipients by ensuring sufficient provider participation.

Effective October 29, 2012, the Department of Health and Hospitals, Bureau of Health Services Financing amends the provisions governing the reimbursement methodology for nursing facilities to establish a supplemental Medicaid payment to nursing facilities who participate in the Low Income and Needy Care Collaboration.

Title 50
PUBLIC HEALTH—MEDICAL ASSISTANCE
Part II. Nursing Facilities
Subpart 5. Reimbursement

Chapter 200. Reimbursement Methodology

§20023. Low Income and Needy Care Collaboration

A. Effective for dates of service on or after November 1, 2011, quarterly supplemental payments shall be issued to qualifying nursing facilities for services rendered during the quarter. Maximum aggregate payments to all qualifying nursing facilities shall not exceed the available upper payment limit per state fiscal year.

B. Qualifying Criteria. In order to qualify for the supplemental payment, the nursing facility must be affiliated with a state or local governmental entity through a Low Income and Needy Care Nursing Facility Collaboration Agreement.

1. A nursing facility is defined as a currently licensed and certified nursing facility which is owned or operated by a private entity or non-state governmental entity.

2. A Low Income and Needy Care Nursing Facility Collaboration Agreement is defined as an agreement between a nursing facility and a state or local governmental entity to collaborate for purposes of providing healthcare services to low income and needy patients.

C. Each qualifying nursing facility shall receive quarterly supplemental payments for nursing facility services. Quarterly payment distribution shall be limited to one-fourth of the aggregated difference between each qualifying nursing facility's Medicare rate and Medicaid payments the nursing facility receives for covered services provided to Medicaid recipients during a 12 consecutive month period. Medicare rates in effect for the dates of service included in the supplemental payment period will be used to establish the upper payment limit. Medicaid payments will be used for the same time period.

AUTHORITY NOTE: Promulgated in accordance with R.S. 36:254 and Title XIX of the Social Security Act.

HISTORICAL NOTE: Promulgated by the Department of Health and Hospitals, Bureau of Health Services Financing, LR 38:

Implementation of the provisions of this Rule may be contingent upon the approval of the U.S. Department of Health and Human Services, Centers for Medicare and Medicaid Services (CMS), if it is determined that submission to CMS for review and approval is required.

Interested persons may submit written comments to J. Ruth Kennedy, Bureau of Health Services Financing, P.O. Box 91030, Baton Rouge, LA 70821-9030. She is responsible for responding to inquiries regarding this Emergency Rule. A copy of this Emergency Rule is available for review by interested parties at parish Medicaid offices.

Bruce D. Greenstein
Secretary

1210#088

DECLARATION OF EMERGENCY

Department of Health and Hospitals
Bureau of Health Services Financing

Nursing Facilities—Reimbursement Rate Reduction
Post-Rebase Rate Cut (LAC 50:II.20005)

The Department of Health and Hospitals, Bureau of Health Services Financing amends LAC 50:II.20005 in the Medical Assistance Program as authorized by R.S. 36:254 and pursuant to Title XIX of the Social Security Act and as directed by House Bill 1 of the 2012 Regular Session of the Louisiana Legislature which states: "The secretary is directed to utilize various cost containment measures to ensure expenditures remain at the level appropriated in this Schedule, including but not limited to precertification, preadmission screening, diversion, fraud control, utilization review and management, prior authorization, service limitations, drug therapy management, disease management, cost sharing, and other measures as permitted under federal law." This Emergency Rule is promulgated in accordance with the provisions of the Administrative Procedure Act, R.S. 49:953(B)(1)et seq., and shall be in effect for the maximum period allowed under the Act or until adoption of the final Rule, whichever occurs first.

The Department of Health and Hospitals, Bureau of Health Services Financing amended the provisions governing the reimbursement methodology for nursing facilities to reduce the per diem rates paid to non-state nursing facilities in order to remove the rebased amount and sunset the 2011-2012 nursing facility rate rebasing (*Louisiana Register*, Volume 38, Number 5).

As a result of a budgetary shortfall in state fiscal year 2013, the department promulgated an Emergency Rule which amended the provisions governing the reimbursement methodology for non-state nursing facilities to further reduce the reimbursement rates (*Louisiana Register*, Volume 38, Number 7).

The Department of Health and Hospitals, Bureau of Health Services Financing promulgated an Emergency Rule which amended the provisions of the July 1, 2012 Emergency Rule governing the SFY 2013 rate reduction to revise the reduction of the per diem rate (*Louisiana Register*, Volume 38, Number 8). This Emergency Rule is being promulgated to continue the provisions of the July 20, 2012 Emergency Rule. This action is being taken to avoid a budget deficit in the medical assistance programs.

Effective November 18, 2012, the Department of Health and Hospitals, Bureau of Health Services Financing amends the provisions governing the reimbursement methodology for non-state nursing facilities.

Title 50
PUBLIC HEALTH—MEDICAL ASSISTANCE
Part II. Nursing Facilities
Subpart 5. Reimbursement
Chapter 200. Reimbursement Methodology
§20005. Rate Determination
[Formerly LAC 50:VII.1305]

A. - K. ...

L. Effective for dates of service on or after July 20, 2012, the average daily rates for non-state nursing facilities shall be reduced by 1.15 percent per day of the average daily rate on file as of July 19, 2012 after the sunset of the state fiscal year 2012 rebase and after the state fiscal year 2013 rebase.

AUTHORITY NOTE: Promulgated in accordance with R.S. 36:254 and Title XIX of the Social Security Act.

HISTORICAL NOTE: Promulgated by the Department of Health and Hospitals, Office of the Secretary, Bureau of Health Services Financing, LR 28:1791 (August 2002), amended LR 31:1596 (July 2005), LR 32:2263 (December 2006), LR 33:2203 (October 2007), amended by the Department of Health and Hospitals, Bureau of Health Services Financing, LR 36:325 (February 2010), repromulgated LR 36:520 (March 2010), amended LR 36:1556 (July 2010), LR 36:1782 (August 2010), LR 36:2566 (November 2010), amended LR 37:902 (March 2011), LR 37:1174 (April 2011), amended LR 37:2631 (September 2011), LR 38:1241 (May 2012), LR 38:

Implementation of the provisions of this Rule may be contingent upon the approval of the U.S. Department of Health and Human Services, Centers for Medicare and Medicaid Services (CMS), if it is determined that submission to CMS for review and approval is required.

Interested persons may submit written comments to J. Ruth Kennedy, Bureau of Health Services Financing, P.O. Box 91030, Baton Rouge, LA 70821-9030. She is responsible for responding to inquiries regarding this Emergency Rule. A copy of this Emergency Rule is available for review by interested parties at parish Medicaid offices.

Bruce D. Greenstein
Secretary

1210#091

DECLARATION OF EMERGENCY

Department of Health and Hospitals
Bureau of Health Services Financing

Nursing Facilities—Reimbursement Rate Reduction
Pre-Rebase Rate Cut (LAC 50:II.20005)

The Department of Health and Hospitals, Bureau of Health Services Financing amends LAC 50:II.20005 in the Medical Assistance Program as authorized by R.S. 36:254 and pursuant to Title XIX of the Social Security Act and as directed by House Bill 1 of the 2012 Regular Session of the Louisiana Legislature which states: “The secretary is directed to utilize various cost containment measures to ensure expenditures remain at the level appropriated in this Schedule, including but not limited to precertification, preadmission screening, diversion, fraud control, utilization review and management, prior authorization, service

limitations, drug therapy management, disease management, cost sharing, and other measures as permitted under federal law.” This proposed Rule is promulgated in accordance with the provisions of the Administrative Procedure Act, R.S. 49:953(B)(1) et seq., and shall be in effect for the maximum period allowed under the Act or until adoption of the final Rule, whichever occurs first.

The Department of Health and Hospitals, Bureau of Health Services Financing amended the provisions governing the reimbursement methodology for nursing facilities to reduce the per diem rates paid to non-state nursing facilities in order to remove the rebased amount and sunset the 2011-2012 nursing facility rate rebasing (*Louisiana Register*, Volume 38, Number 5).

As a result of a budgetary shortfall in state fiscal year 2013, the department promulgated an Emergency Rule which amended the provisions governing the reimbursement methodology for non-state nursing facilities to reduce the reimbursement rates (*Louisiana Register*, Volume 38, Number 7). This Emergency Rule is being promulgated to continue the provisions of the July 1, 2012 Emergency Rule). This action is being taken to avoid a budget deficit in the medical assistance programs.

Effective October 30, 2012, the Department of Health and Hospitals, Bureau of Health Services Financing amends the provisions governing the reimbursement methodology for non-state nursing facilities to reduce the reimbursement rates.

Title 50
PUBLIC HEALTH—MEDICAL ASSISTANCE
Part II. Nursing Facilities
Subpart 5. Reimbursement
Chapter 200. Reimbursement Methodology
§20005. Rate Determination
[Formerly LAC 50:VII.1305]

A. - I. ...

J. Effective for dates of service on or after July 1, 2012, the average daily rates for non-state nursing facilities shall be reduced by \$4.11 per day of the average daily rate on file as of June 30, 2012 after the sunset of the state fiscal year 2012 rebase and before the state fiscal year 2013 rebase.

AUTHORITY NOTE: Promulgated in accordance with R.S. 36:254 and Title XIX of the Social Security Act.

HISTORICAL NOTE: Promulgated by the Department of Health and Hospitals, Office of the Secretary, Bureau of Health Services Financing, LR 28:1791 (August 2002), amended LR 31:1596 (July 2005), LR 32:2263 (December 2006), LR 33:2203 (October 2007), amended by the Department of Health and Hospitals, Bureau of Health Services Financing, LR 36:325 (February 2010), repromulgated LR 36:520 (March 2010), amended LR 36:1556 (July 2010), LR 36:1782 (August 2010), LR 36:2566 (November 2010), amended LR 37:902 (March 2011), LR 37:1174 (April 2011), amended LR 37:2631 (September 2011), LR 38:1241 (May 2012), LR 38:

Implementation of the provisions of this Rule may be contingent upon the approval of the U.S. Department of Health and Human Services, Centers for Medicare and Medicaid Services (CMS), if it is determined that submission to CMS for review and approval is required.

Interested persons may submit written comments to J. Ruth Kennedy, Bureau of Health Services Financing, P.O.

Box 91030, Baton Rouge, LA 70821-9030. She is responsible for responding to inquiries regarding this Emergency Rule. A copy of this Emergency Rule is available for review by interested parties at parish Medicaid offices.

Bruce D. Greenstein
Secretary

1210#090

DECLARATION OF EMERGENCY

Department of Health and Hospitals Bureau of Health Services Financing

Nursing Facilities
Reimbursement Methodology
Private Room Conversions
(LAC 50:II.20010)

The Department of Health and Hospitals, Bureau of Health Services Financing amends LAC 50:II.20010 in the Medical Assistance Program as authorized by R.S. 36:254 and pursuant to Title XIX of the Social Security Act. This Emergency Rule is promulgated in accordance with the provisions of the Administrative Procedure Act, R.S. 49:953(B)(1) et seq., and shall be in effect for the maximum period allowed under the Act or until adoption if the final Rule, whichever occurs first.

The Department of Health and Hospitals, Office of the Secretary, Bureau of Health Services Financing amended the provisions governing the reimbursement methodology for nursing facilities to allow for additional payments for private room conversions when a Medicaid participating nursing facility converts one or more semi-private rooms to private rooms for occupancy by Medicaid recipients (*Louisiana Register*, Volume 33, Number 8). Act 150 of the 2010 Regular Session of the Louisiana Legislature directed the department to increase the fair rental value minimum occupancy percentage from 70 percent to 85 percent. The department promulgated an Emergency Rule which amended the provisions governing the reimbursement methodology for nursing facilities to ensure that the provisions governing private room conversions are consistent with the increase in the fair rental value minimum occupancy percentage which was adopted on July 1, 2011 (*Louisiana Register*, Volume 37, Number 10). This Emergency Rule is being promulgated to continue the provisions of the November 1, 2011 Emergency Rule. This action is being taken in order to avoid a budget deficit in the medical assistance programs.

Effective October 29, 2012, the Department of Health and Hospitals, Bureau of Health Services Financing amends the provisions governing the reimbursement methodology for nursing facilities.

Title 50

PUBLIC HEALTH-MEDICAL ASSISTANCE

Part II. Nursing Facilities

Subpart 5. Reimbursement

Chapter 200. Reimbursement Methodology

§20010. Additional Payments and Square Footage

Adjustments for Private Room Conversion

[Formerly LAC 50:VII.1310]

A. - D.2.c. ...

3. Resident days used in the fair rental value per diem calculation will be the greater of the annualized actual resident days from the base year cost report or 85 percent of the revised annual bed days available after the change in licensed beds.

D.4 - E.2. ...

AUTHORITY NOTE: Promulgated in accordance with R.S. 36:254, R.S. 46:2742, and Title XIX of the Social Security Act.

HISTORICAL NOTE: Promulgated by the Department of Health and Hospitals, Office of the Secretary, Bureau of Health Services Financing, LR 33:1646 (August 2007), amended by the Department of Health and Hospitals, Bureau of Health Services Financing, LR 38:

Interested persons may submit written comments to J. Ruth Kennedy, Bureau of Health Services Financing, P.O. Box 91030, Baton Rouge, LA 70821-9030. She is responsible for responding to inquiries regarding this Emergency Rule. A copy of this Emergency Rule is available for review by interested parties at parish Medicaid offices.

Bruce D. Greenstein
Secretary

1210#089

DECLARATION OF EMERGENCY

Department of Health and Hospitals Bureau of Health Services Financing

Outpatient Hospital Services—Non-Rural, Non-State
Public Hospitals—Supplemental Payments
(LAC 50:V.5315, 5515, 5717, 5915 and 6117)

The Department of Health and Hospitals, Bureau of Health Services Financing adopts LAC 50:V.5315, §5515, §5717, §5915 and §6117 in the Medical Assistance Program as authorized by R.S. 36:254 and pursuant to Title XIX of the Social Security Act. This Emergency Rule is promulgated in accordance with the provisions of the Administrative Procedure Act, R.S. 49:953(B)(1) et seq., and shall be in effect for the maximum period allowed under the Act or until adoption of the final Rule, whichever occurs first.

Act 228 of the 2009 Regular Session of the Louisiana Legislature directed the department to issue a supplemental payment to hospitals that demonstrated substantial financial and operational challenges in the aftermath of Hurricanes Katrina, Rita, Gustav and Ike. In compliance with Act 228, the department amended the provisions governing the reimbursement methodology for outpatient hospital services to provide a supplemental Medicaid payment to non-rural, non-state public hospitals (*Louisiana Register*, Volume 36, Number 12).

The department now proposes to amend the provisions governing the reimbursement methodology for outpatient hospital services to provide supplemental Medicaid payments to qualifying non-rural, non-state public hospitals for state fiscal year 2013. This action is being taken to promote the health and welfare of Medicaid recipients by ensuring sufficient provider participation in the Hospital Services Program and ensuring recipient access to providers of these medically necessary services. It is anticipated that this Emergency Rule will increase expenditures for

outpatient hospital services by approximately \$7,786,803 for state fiscal year 2013-2014.

Effective October 1, 2012, the Department of Health and Hospitals, Bureau of Health Services Financing amends the provisions governing the reimbursement methodology for outpatient hospital services rendered by non-rural, non-state public hospitals.

Title 50

PUBLIC HEALTH—MEDICAL ASSISTANCE

Part V. Hospital Services

Subpart 5. Outpatient Hospitals

Chapter 53. Outpatient Surgery

Subchapter B. Reimbursement Methodology

§5315. Non-Rural, Non-State Public Hospitals

A. Effective for dates of service on or after October 1, 2012, quarterly supplemental payments may be issued to qualifying non-rural, non-state public hospitals for outpatient surgical services rendered during the quarter. Payment amounts may be reimbursed up to the Medicare inpatient upper payment limits as determined in accordance with 42 CFR §447.272.

1. Qualifying criteria. In order to qualify for the quarterly supplemental payment, the non-rural, non-state public acute care hospital must be designated as a major teaching hospital by the department in state fiscal year 2011 and have provided at least 17,000 Medicaid acute care and distinct part psychiatric unit paid days for state fiscal year 2010 dates of service.

2. Each qualifying hospital may receive quarterly supplemental payments for the outpatient services rendered during the quarter. Quarterly payments may be the difference between each qualifying hospital's outpatient Medicaid billed charges and the Medicaid payments the hospital receives for covered outpatient services provided to Medicaid recipients. Medicaid billed charges and payments will be based on a 12 consecutive month period for claims data selected by the department.

AUTHORITY NOTE: Promulgated in accordance with R.S. 36:254 and Title XIX of the Social Security Act.

HISTORICAL NOTE: Promulgated by the Department of Health and Hospitals, Bureau of Health Services Financing, LR 36:2867 (December 2010), amended LR 38:

Chapter 55. Clinic Services

Subchapter B. Reimbursement Methodology

§5515. Non-Rural, Non-State Public Hospitals

A. Effective for dates of service on or after October 1, 2012, quarterly supplemental payments may be issued to qualifying non-rural, non-state public hospitals for clinic services rendered during the quarter. Payment amounts may be reimbursed up to the Medicare inpatient upper payment limits as determined in accordance with 42 CFR §447.272.

1. Qualifying criteria. In order to qualify for the quarterly supplemental payment, the non-rural, non-state public acute care hospital must be designated as a major teaching hospital by the department in state fiscal year 2011 and have provided at least 17,000 Medicaid acute care and distinct part psychiatric unit paid days for state fiscal year 2010 dates of service.

2. Each qualifying hospital may receive quarterly supplemental payments for the outpatient services rendered during the quarter. Quarterly payments may be the difference

between each qualifying hospital's outpatient Medicaid billed charges and the Medicaid payments the hospital receives for covered outpatient services provided to Medicaid recipients. Medicaid billed charges and payments will be based on a 12 consecutive month period for claims data selected by the department.

AUTHORITY NOTE: Promulgated in accordance with R.S. 36:254 and Title XIX of the Social Security Act.

HISTORICAL NOTE: Promulgated by the Department of Health and Hospitals, Bureau of Health Services Financing, LR 36:2867 (December 2010), amended LR 38:

Chapter 57. Laboratory Services

Subchapter B. Reimbursement Methodology

§5717. Non-Rural, Non-State Public Hospitals

A. Effective for dates of service on or after October 1, 2012, quarterly supplemental payments may be issued to qualifying non-rural, non-state public hospitals for laboratory services rendered during the quarter. Payment amounts may be reimbursed up to the Medicare inpatient upper payment limits as determined in accordance with 42 CFR §447.272.

1. Qualifying Criteria. In order to qualify for the quarterly supplemental payment, the non-rural, non-state public acute care hospital must be designated as a major teaching hospital by the department in state fiscal year 2011 and have provided at least 17,000 Medicaid acute care and distinct part psychiatric unit paid days for state fiscal year 2010 dates of service.

2. Each qualifying hospital may receive quarterly supplemental payments for the outpatient services rendered during the quarter. Quarterly payments may be the difference between each qualifying hospital's outpatient Medicaid billed charges and the Medicaid payments the hospital receives for covered outpatient services provided to Medicaid recipients. Medicaid billed charges and payments will be based on a 12 consecutive month period for claims data selected by the department.

AUTHORITY NOTE: Promulgated in accordance with R.S. 36:254 and Title XIX of the Social Security Act.

HISTORICAL NOTE: Promulgated by the Department of Health and Hospitals, Bureau of Health Services Financing, LR 36:2868 (December 2010), LR 38:

Chapter 59. Rehabilitation Services

Subchapter B. Reimbursement Methodology

§5915. Non-Rural, Non-State Public Hospitals

A. Effective for dates of service on or after October 1, 2012, quarterly supplemental payments may be issued to qualifying non-rural, non-state public hospitals for rehabilitation services rendered during the quarter. Payment amounts may be reimbursed up to the Medicare inpatient upper payment limits as determined in accordance with 42 CFR §447.272.

1. Qualifying criteria. In order to qualify for the quarterly supplemental payment, the non-rural, non-state public acute care hospital must be designated as a major teaching hospital by the department in state fiscal year 2011 and have provided at least 17,000 Medicaid acute care and distinct part psychiatric unit paid days for state fiscal year 2010 dates of service.

2. Each qualifying hospital may receive quarterly supplemental payments for the outpatient services rendered during the quarter. Quarterly payments may be the difference

between each qualifying hospital's outpatient Medicaid billed charges and the Medicaid payments the hospital receives for covered outpatient services provided to Medicaid recipients. Medicaid billed charges and payments will be based on a 12 consecutive month period for claims data selected by the department.

AUTHORITY NOTE: Promulgated in accordance with R.S. 36:254 and Title XIX of the Social Security Act.

HISTORICAL NOTE: Promulgated by the Department of Health and Hospitals, Bureau of Health Services Financing, LR 36:2867 (December 2010), amended LR 38:

Chapter 61. Other Outpatient Hospital Services

Subchapter B. Reimbursement Methodology

§6117. Non-Rural, Non-State Public Hospitals

A. Effective for dates of service on or after October 1, 2012, quarterly supplemental payments may be issued to qualifying non-rural, non-state public hospitals for outpatient services other than clinic services, diagnostic laboratory services, outpatient surgeries and rehabilitation services rendered during the quarter. Payment amounts may be reimbursed up to the Medicare inpatient upper payment limits as determined in accordance with 42 CFR §447.272.

1. Qualifying criteria. In order to qualify for the quarterly supplemental payment, the non-rural, non-state public acute care hospital must be designated as a major teaching hospital by the department in state fiscal year 2011 and have provided at least 17,000 Medicaid acute care and distinct part psychiatric unit paid days for state fiscal year 2010 dates of service.

2. Each qualifying hospital may receive quarterly supplemental payments for the outpatient services rendered during the quarter. Quarterly payments may be the difference between each qualifying hospital's outpatient Medicaid billed charges and the Medicaid payments the hospital receives for covered outpatient services provided to Medicaid recipients. Medicaid billed charges and payments will be based on a 12 consecutive month period for claims data selected by the department.

AUTHORITY NOTE: Promulgated in accordance with R.S. 36:254 and Title XIX of the Social Security Act.

HISTORICAL NOTE: Promulgated by the Department of Health and Hospitals, Bureau of Health Services Financing, LR 36:2867 (December 2010), amended LR 38:

Implementation of the provisions of this Rule may be contingent upon the approval of the U.S. Department of Health and Human Services, Centers for Medicare and Medicaid Services (CMS), if it is determined that submission to CMS for review and approval is required.

Interested persons may submit written comments to J. Ruth Kennedy, Bureau of Health Services Financing, P.O. Box 91030, Baton Rouge, LA 70821-9030. She is responsible for responding to all inquiries regarding this Emergency Rule. A copy of this Emergency Rule is available for review by interested parties at parish Medicaid offices.

Bruce D. Greenstein
Secretary

1210#014

DECLARATION OF EMERGENCY

**Department of Health and Hospitals
Bureau of Health Services Financing**

Outpatient Hospital Services
State-Owned Hospitals
Medical Education Payments
(LAC 50:V.5319, 5519, 5919 and 6127)

The Department of Health and Hospitals, Bureau of Health Services Financing adopts LAC 50:V.5319, §5519, §5919 and amends §6127 in the Medical Assistance Program as authorized by R.S. 36:254 and pursuant to Title XIX of the Social Security Act. This Emergency Rule is promulgated in accordance with the provisions of the Administrative Procedure Act, R.S. 49:953(B)(1) et seq., and shall be in effect for the maximum period allowed under the Act or until adoption of the final Rule, whichever occurs first.

The Department of Health and Hospitals, Bureau of Health Services Financing adopted provisions under the Medicaid State Plan to establish a coordinated system of care through an integrated network for the delivery of healthcare services to Medicaid recipients (*Louisiana Register*, Volume 37, Number 6). This delivery system, comprised of managed care organizations (MCOs), was implemented to improve performance and health care outcomes for Medicaid recipients. The per member per month reimbursements to MCOs do not include payments for medical education services rendered by participating hospitals.

Therefore, the department promulgated an Emergency Rule which amended the provisions governing the reimbursement methodology for outpatient hospital services in order to continue medical education payments to state-owned hospitals when the hospitals are reimbursed by prepaid risk-bearing MCOs for outpatient surgeries, clinic services, rehabilitation services, and other covered outpatient hospital services (*Louisiana Register*, Volume 38, Number 2).

The Department of Health and Hospitals, Bureau of Health Services Financing promulgated an Emergency Rule which amended the February 10, 2012 Emergency Rule to clarify the provisions governing the reimbursement methodology for outpatient hospital services (*Louisiana Register*, Volume 38, Number 3). This Emergency Rule is being promulgated to continue the provisions of the March 20, 2012 Emergency Rule. This action is being taken to promote the health and welfare of Medicaid recipients by ensuring sufficient provider participation and recipient access to services.

Effective November 17, 2012, the Department of Health and Hospitals, Bureau of Health Services Financing amends the provisions governing the reimbursement methodology for outpatient hospital services.

Title 50
PUBLIC HEALTH—MEDICAL ASSISTANCE

Part V. Hospital Services

Subpart 5. Outpatient Hospital Services

Chapter 53. Outpatient Surgery

Subchapter B. Reimbursement Methodology

§5319. State-Owned Hospitals

A. Effective for dates of service on or after February 1, 2012, medical education payments for outpatient surgery services which are reimbursed by a prepaid risk-bearing managed care organization (MCO) shall be reimbursed by Medicaid annually through the Medicaid cost report settlement process.

1. For purposes of these provisions, *qualifying medical education programs* are defined as graduate medical education, paramedical education, and nursing schools.

2. Final payment shall be determined based on the actual MCO covered outpatient surgery services and Medicaid medical education costs for the cost reporting period per the Medicaid cost report.

AUTHORITY NOTE: Promulgated in accordance with R.S. 36:254 and Title XIX of the Social Security Act.

HISTORICAL NOTE: Promulgated by the Department of Health and Hospitals, Bureau of Health Services Financing, LR 38:

Chapter 55. Clinic Services

Subchapter B. Reimbursement Methodology

§5519. State-Owned Hospitals

A. Effective for dates of service on or after February 10, 2012, medical education payments for outpatient clinic services which are reimbursed by a prepaid risk-bearing managed care organization (MCO) shall be reimbursed by Medicaid annually through the Medicaid cost report settlement process.

1. *Qualifying Medical Education Programs*—graduate medical education, paramedical education, and nursing schools.

2. Final payment shall be determined based on the actual MCO covered outpatient clinic services and Medicaid medical education costs for the cost reporting period per the Medicaid cost report.

AUTHORITY NOTE: Promulgated in accordance with R.S. 36:254 and Title XIX of the Social Security Act.

HISTORICAL NOTE: Promulgated by the Department of Health and Hospitals, Bureau of Health Services Financing, LR 38:

Chapter 59. Rehabilitation Services

Subchapter B. Reimbursement Methodology

§5919. State-Owned Hospitals

A. Effective for dates of service on or after February 10, 2012, medical education payments for outpatient rehabilitation services which are reimbursed by a prepaid risk-bearing managed care organization (MCO) shall be reimbursed by Medicaid annually through the Medicaid cost report settlement process.

1. *Qualifying Medical Education Programs*—graduate medical education, paramedical education, and nursing schools.

2. Final payment shall be determined based on the actual MCO covered outpatient rehabilitation services and Medicaid medical education costs for the cost reporting period per the Medicaid cost report.

AUTHORITY NOTE: Promulgated in accordance with R.S. 36:254 and Title XIX of the Social Security Act.

HISTORICAL NOTE: Promulgated by the Department of Health and Hospitals, Bureau of Health Services Financing, LR 38:

Chapter 61. Other Outpatient Hospital Services

Subchapter B. Reimbursement Methodology

§6127. State-Owned Hospitals

A. ...

B. Effective for dates of service on or after February 1, 2012, medical education payments which are reimbursed by a prepaid risk-bearing managed care organization (MCO) shall be reimbursed by Medicaid annually through the Medicaid cost report settlement process to state-owned hospitals for outpatient hospital services other than outpatient surgery services, clinic services, laboratory services, and rehabilitation services.

1. *Qualifying Medical Education Programs*—graduate medical education, paramedical education, and nursing schools.

2. Final payment shall be determined based on the actual MCO covered outpatient services and Medicaid medical education costs for the cost reporting period per the Medicaid cost report.

AUTHORITY NOTE: Promulgated in accordance with R.S. 36:254 and Title XIX of the Social Security Act.

HISTORICAL NOTE: Promulgated by the Department of Health and Hospitals, Office of the Secretary, Bureau of Health Services Financing, LR 35:957 (May 2009), amended by the Department of Health and Hospitals, Bureau of Health Services Financing, LR 38:

Implementation of the provisions of this Rule may be contingent upon the approval of the U.S. Department of Health and Human Services, Centers for Medicare and Medicaid Services (CMS) if it is determined that submission to CMS for review and approval is required.

Interested persons may submit written comments to J. Ruth Kennedy, Bureau of Health Services Financing, P.O. Box 91030, Baton Rouge, LA 70821-9030. She is responsible for responding to inquiries regarding this Emergency Rule. A copy of this Emergency Rule is available for review by interested parties at parish Medicaid offices.

Bruce D. Greenstein
Secretary

1210#093

DECLARATION OF EMERGENCY

**Department of Health and Hospitals
Bureau of Health Services Financing**

Bureau of Health Services Financing
Pediatric Day Health Care Program
Reimbursement Rate Reduction
(LAC 50:XV.28101)

The Department of Health and Hospitals, Bureau of Health Services Financing amends LAC 50:XV.28101 in the Medical Assistance Program as authorized by R.S. 36:254 and pursuant to Title XIX of the Social Security Act and as directed by House Bill 1 of the 2012 Regular Session of the Louisiana Legislature which states: "The secretary is directed to utilize various cost containment measures to ensure expenditures remain at the level appropriated in this

Schedule, including but not limited to precertification, preadmission screening, diversion, fraud control, utilization review and management, prior authorization, service limitations, drug therapy management, disease management, cost sharing, and other measures as permitted under federal law.” This Emergency Rule is promulgated in accordance with the provisions of the Administrative Procedure Act, R.S. 49:953(B)(1) et seq., and shall be in effect for the maximum period allowed under the Act or until adoption of the final Rule, whichever occurs first.

The Department of Health and Hospitals, Bureau of Health Services Financing adopted provisions to implement pediatric day health care services as an optional covered service in the Medical Assistance Program (*Louisiana Register*, Volume 36, Number 7).

Due to a budgetary shortfall in state fiscal year 2013, the department promulgated an Emergency Rule which amended the provisions governing the reimbursement methodology for pediatric day health care services to reduce the reimbursement rates (*Louisiana Register*, Volume 38, Number 7). This Emergency Rule is being promulgated to continue the provisions of the July 1, 2012 Emergency Rule. This action is being taken to avoid a budget deficit in the medical assistance programs.

Effective October 30, 2012, the Department of Health and Hospitals, Bureau of Health Services Financing amends the provisions governing the reimbursement methodology for pediatric day health care services to reduce the reimbursement rates.

Title 50

PUBLIC HEALTH—MEDICAL ASSISTANCE

Part XV. Services For Special Populations

Subpart 19. Pediatric Day Health Care

Chapter 281. Reimbursement Methodology

§28101. General Provisions

A. - B. ...

C. Effective for dates of service on or after July 1, 2012, the reimbursement for pediatric day health care services shall be reduced by 3.7 percent of the rates in effect on June 30, 2012.

AUTHORITY NOTE: Promulgated in accordance with R.S. 36:254 and Title XIX of the Social Security Act.

HISTORICAL NOTE: Promulgated by the Department of Health and Hospitals, Bureau of Health Services Financing, LR 36:1558 (July 2010), amended LR 38:

Implementation of the provisions of this Rule may be contingent upon the approval of the U.S. Department of Health and Human Services, Centers for Medicare and Medicaid Services (CMS), if it is determined that submission to CMS for review and approval is required.

Interested persons may submit written comments to J. Ruth Kennedy, Bureau of Health Services Financing, P.O. Box 91030, Baton Rouge, LA 70821-9030. She is responsible for responding to inquiries regarding this Emergency Rule. A copy of this Emergency Rule is available for review by interested parties at parish Medicaid offices.

Bruce D. Greenstein
Secretary

1210#094

DECLARATION OF EMERGENCY

Department of Health and Hospitals Bureau of Health Services Financing

Personal Care Services—Long Term Cost Reporting Requirements (LAC 50:XV.12919)

The Department of Health and Hospitals, Bureau of Health Services Financing adopts LAC 50:XV.12919 in the Medical Assistance Program as authorized by R.S. 36:254 and pursuant to Title XIX of the Social Security Act. This Emergency Rule is promulgated in accordance with the provisions of the Administrative Procedure Act, R.S. 49:953(B)(1) et seq., and shall be in effect for the maximum period allowed under the Act or until adoption of the final Rule, whichever occurs first.

Act 299 of the 2011 Regular Session of the Louisiana Legislature directed the Department of Health and Hospitals to establish mandatory cost reporting requirements for providers of home and community-based services to verify expenditures and for use in determining appropriate reimbursement rates. In compliance with Act 299, the department promulgated an Emergency Rule which adopted provisions establishing cost reporting requirements for providers of long-term personal care services (*Louisiana Register*, Volume 38, Number 7). This Emergency Rule is being promulgated to continue the provisions of the July 1, 2012 Emergency Rule. This action is being taken to promote the health and welfare of Medicaid recipients and to ensure that these services are rendered in an efficient and cost-effective manner.

Effective October 30, 2012, the Department of Health and Hospitals, Bureau of Health Services Financing adopts provisions to establish cost reporting requirements for providers of long-term personal care services.

Title 50

PUBLIC HEALTH—MEDICAL ASSISTANCE

Part XV. Services for Special Populations

Subpart 9. Personal Care Services

Chapter 129. Long Term Care

§12919. Cost Reporting Requirements

A. Effective July 1, 2012, the department shall implement mandatory cost reporting requirements for providers of long-term personal care services. The cost reports will be used to verify expenditures and to support rate setting for the services rendered to Medicaid recipients.

B. Each LT-PCS provider shall complete the DHH approved cost report and submit the cost report(s) to the department no later than five months after the state fiscal year ends (June 30).

AUTHORITY NOTE: Promulgated in accordance with R.S. 36:254 and Title XIX of the Social Security Act.

HISTORICAL NOTE: Promulgated by the Department of Health and Hospitals, Bureau of Health Services Financing, LR 38:

Implementation of the provisions of this Rule may be contingent upon the approval of the U.S. Department of Health and Human Services, Centers for Medicare and

Medicaid Services (CMS), if it is determined that submission to CMS for review and approval is required.

Interested persons may submit written comments to J. Ruth Kennedy, Bureau of Health Services Financing, P.O. Box 91030, Baton Rouge, LA 70821-9030. She is responsible for responding to inquiries regarding this Emergency Rule. A copy of this Emergency Rule is available for review by interested parties at parish Medicaid offices.

Bruce D. Greenstein
Secretary

1210#095

DECLARATION OF EMERGENCY

Department of Health and Hospitals Bureau of Health Services Financing and Office of Aging and Adult Services

Personal Care Services—Long Term Reimbursement Rate Reduction (LAC 50:XV.12917)

The Department of Health and Hospitals, Bureau of Health Services Financing and the Office of Aging and Adult Services amend LAC 50:XV.12917 in the Medical Assistance Program as authorized by R.S. 36:254 and pursuant to Title XIX of the Social Security Act and as directed by House Bill 1 of the 2012 Regular Session of the Louisiana Legislature which states: “The secretary is directed to utilize various cost containment measures to ensure expenditures remain at the level appropriated in this Schedule, including but not limited to precertification, preadmission screening, diversion, fraud control, utilization review and management, prior authorization, service limitations, drug therapy management, disease management, cost sharing, and other measures as permitted under federal law.” This Emergency Rule is promulgated in accordance with the provisions of the Administrative Procedure Act, R.S. 49:953(B)(1) et seq., and shall be in effect for the maximum period allowed under the Act or until adoption of the final Rule, whichever occurs first.

Due to a continuing budgetary shortfall, the Department of Health and Hospitals, Bureau of Health Services Financing amended the provisions governing the reimbursement methodology for long-term personal care services to reduce the reimbursement rates (Louisiana Register, Volume 37, Number 11).

As a result of a budgetary shortfall in state fiscal year 2013, the department promulgated an Emergency Rule which amended the provisions governing the reimbursement methodology for long-term personal care services to reduce the reimbursement rates (*Louisiana Register*, Volume 38, Number 7). This Emergency Rule is being promulgated to continue the provisions of the July 1, 2012 Emergency Rule. This action is being taken to avoid a budget deficit in the medical assistance programs.

Effective October 30, 2012, the Department of Health and Hospitals, Bureau of Health Services Financing amends the provisions governing the reimbursement methodology for long-term personal care services to reduce the reimbursement rates.

Title 50

PUBLIC HEALTH—MEDICAL ASSISTANCE

Part XV. Services for Special Populations

Subpart 9. Personal Care Services

Chapter 129. Long-Term Care

§12917. Reimbursement Methodology

A. - H.2....

I. Effective for dates of service on or after July 1, 2012, the reimbursement rate for long-term personal care services furnished to one participant shall be reduced by 1.5 percent of the rate on file as of June 30, 2012.

AUTHORITY NOTE: Promulgated in accordance with R.S. 36:254 and Title XIX of the Social Security Act.

HISTORICAL NOTE: Promulgated by the Department of Health and Hospitals, Office of the Secretary, Bureau of Health Services Financing, LR 29:913 (June 2003), amended by the Department of Health and Hospitals, Office of Aging and Adult Services, LR 34:253 (February 2008), LR 34:2581 (December 2008), amended by the Department of Health and Hospitals, Bureau of Health Services Financing and the Office of Aging and Adult Services, LR 35:1901 (September 2009), LR 36:1251 (June 2010), LR 37:3267 (November 2011), LR 38:

Implementation of the provisions of this Rule may be contingent upon the approval of the U.S. Department of Health and Human Services, Centers for Medicare and Medicaid Services (CMS), if it is determined that submission to CMS for review and approval is required.

Interested persons may submit written comments to J. Ruth Kennedy, Bureau of Health Services Financing, P.O. Box 91030, Baton Rouge, LA 70821-9030. She is responsible for responding to inquiries regarding this Emergency Rule. A copy of this Emergency Rule is available for review by interested parties at parish Medicaid offices.

Bruce D. Greenstein
Secretary

1210#096

DECLARATION OF EMERGENCY

Department of Health and Hospitals Bureau of Health Services Financing

Pregnant Women Extended Services Dental Services Reimbursement Rate Reduction (LAC 50:XV.16107)

The Department of Health and Hospitals, Bureau of Health Services Financing amends LAC 50:XV.16107 in the Medical Assistance Program as authorized by R.S. 36:254 and pursuant to Title XIX of the Social Security Act and as directed by House Bill 1 of the 2012 Regular Session of the Louisiana Legislature which states: “The secretary is directed to utilize various cost containment measures to ensure expenditures remain at the level appropriated in this Schedule, including but not limited to precertification, preadmission screening, diversion, fraud control, utilization review and management, prior authorization, service limitations, drug therapy management, disease management, cost sharing, and other measures as permitted under federal law.” This Emergency Rule is promulgated in accordance with the provisions of the Administrative Procedure Act, R.S. 49:953(B)(1) et seq., and shall be in effect for the

maximum period allowed under the Act or until adoption of the final Rule, whichever occurs first.

As a result of a budgetary shortfall in state fiscal year 2011, the Department of Health and Hospitals, Bureau of Health Services Financing amended the provisions governing the reimbursement methodology for dental services to reduce the reimbursement rates for services rendered to Medicaid eligible pregnant women (*Louisiana Register*, Volume 37, Number 11).

Due to a budgetary shortfall in state fiscal year 2013, the department promulgated an Emergency Rule which amended the provisions governing the reimbursement methodology for dental services rendered to Medicaid eligible pregnant women to reduce the reimbursement rates. This action is being taken to avoid a budget deficit in the medical assistance programs (*Louisiana Register*, Volume 38, Number 7). This Emergency Rule is being promulgated to continue the provisions of the July 1, 2012 Emergency Rule.

Effective October 30, 2012, the Department of Health and Hospitals, Bureau of Health Services Financing amends the provisions governing the reimbursement methodology for dental services rendered to Medicaid eligible pregnant women to reduce the reimbursement rates.

Title 50

PUBLIC HEALTH—MEDICAL ASSISTANCE

Part XV. Services for Special Populations

Subpart 13. Pregnant Women Extended Services

Chapter 161. Dental Services

§16107. Reimbursement

A. - F.3.q. ...

G. Effective for dates of service on or after July 1, 2012, the reimbursement fees for dental services provided to Medicaid eligible pregnant women shall be reduced to the following percentages of the 2009 National Dental Advisory Service Comprehensive Fee Report 70th percentile, unless otherwise stated in this Chapter:

1. 65 percent for the comprehensive periodontal evaluation exam;
2. 62 percent for the following diagnostic and preventive services
 - a. intraoral-periapical first film;
 - b. intraoral-periapical, each additional film; and
 - c. panoramic film and prophylaxis, adult; and
3. 56 percent for the remaining diagnostic services and all periodontic procedures, restorative and oral and maxillofacial surgery procedures.

AUTHORITY NOTE: Promulgated in accordance with R.S. 36:254 and Title XIX of the Social Security Act.

HISTORICAL NOTE: Promulgated by the Department of Health and Hospitals, Office of the Secretary, Bureau of Health Services Financing, LR 30:434 (March 2004), amended by the Department of Health and Hospitals, Bureau of Health Services Financing, LR 35:1902 (September 2009), amended LR 36:2044 (September 2010), LR 37:3270 (November 2011), LR 38:

Implementation of the provisions of this Rule may be contingent upon the approval of the U.S. Department of Health and Human Services, Centers for Medicare and Medicaid Services (CMS), if it is determined that submission to CMS for review and approval is required.

Interested persons may submit written comments to J. Ruth Kennedy, Bureau of Health Services Financing, P.O.

Box 91030, Baton Rouge, LA 70821-9030. She is responsible for responding to inquiries regarding this Emergency Rule. A copy of this Emergency Rule is available for review by interested parties at parish Medicaid offices.

Bruce D. Greenstein
Secretary

1210#097

DECLARATION OF EMERGENCY

Department of Health and Hospitals Bureau of Health Services Financing

Professional Services Program
Anesthesia Services
Reimbursement Rate Reduction
(LAC 50:IX.15133 and 15135)

The Department of Health and Hospitals, Bureau of Health Services Financing amends LAC 50:IX.15133 and §15135 in the Medical Assistance Program as authorized by R.S. 36:254 and pursuant to Title XIX of the Social Security Act and as directed by House Bill 1 of the 2012 Regular Session of the Louisiana Legislature which states: "The secretary is directed to utilize various cost containment measures to ensure expenditures remain at the level appropriated in this Schedule, including but not limited to precertification, preadmission screening, diversion, fraud control, utilization review and management, prior authorization, service limitations, drug therapy management, disease management, cost sharing, and other measures as permitted under federal law." This Emergency Rule is promulgated in accordance with the provisions of the Administrative Procedure Act, R.S. 49:953(B)(1) et seq., and shall be in effect for the maximum period allowed under the Act or until adoption of the final Rule, whichever occurs first.

The Department of Health and Hospitals, Bureau of Health Services Financing amended the provisions governing anesthesia services in order to revise the formula-based reimbursement methodology for services rendered by physicians and certified registered nurse anesthetists (CRNAs), and to reorganize these provisions in a clear and concise manner in the *Louisiana Administrative Code* (*Louisiana Register*, Volume 36, Number 6).

As a result of a budgetary shortfall in state fiscal year 2013, the department promulgated an Emergency Rule which amended the provisions governing the reimbursement methodology for anesthesia services to reduce the reimbursement rates (*Louisiana Register*, Volume 38, Number 7). The department promulgated an Emergency Rule that amended the July 1, 2012 Emergency Rule to adjust the rate reduction and to include certified registered nurse anesthetists in the rate reduction (*Louisiana Register*, Volume 38, Number 8). This Emergency Rule is being promulgated to continue the provisions of the July 20, 2012 Emergency Rule. This action is being taken to avoid a budget deficit in the medical assistance programs.

Effective November 18, 2012, the Department of Health and Hospitals, Bureau of Health Services Financing amends

the provisions governing the reimbursement methodology for anesthesia services.

Title 50
PUBLIC HEALTH—MEDICAL ASSISTANCE
Part IX. Professional Services Program
Subpart 15. Reimbursement
Chapter 151. Reimbursement Methodology
Subchapter D. Anesthesia Services
§15133. Formula-Based Reimbursement

A. - C. 2. ...

D. Effective for dates of service on or after July 1, 2012, the reimbursement for formula-based anesthesia services shall be reduced by 3.7 percent of the rates in effect on June 30, 2012.

E. Effective for dates of service on or after July 20, 2012, the 3.7 percent reimbursement rate reduction for formula-based anesthesia services shall be adjusted to 3.4 percent of the rates in effect on June 30, 2012.

F. Effective for dates of service on or after July 20, 2012, the reimbursement for formula-based anesthesia services rendered by a CRNA shall be reduced by 3.4 percent of the rates in effect on July 19, 2012.

AUTHORITY NOTE: Promulgated in accordance with R.S. 36:254 and Title XIX of the Social Security Act.

HISTORICAL NOTE: Promulgated by the Department of Health and Hospitals, Bureau of Health Services Financing, LR 36:1251 (June 2010), amended LR 36:2282 (October 2010), LR 38:

§15135. Flat Fee Reimbursement

A. - D.1....

E. Effective for dates of service on or after July 1, 2012, the flat fee reimbursement rates paid for anesthesia services shall be reduced by 3.7 percent of the rates in effect on June 30, 2012.

F. Effective for dates of service on or after July 20, 2012, the 3.7 percent rate reduction for flat fee reimbursement of anesthesia services shall be adjusted to 3.4 percent of the rates in effect on June 30, 2012.

G. Effective for dates of service on or after July 20, 2012, the flat fee reimbursement for anesthesia services rendered by a CRNA shall be reduced by 3.4 percent of the rates in effect on July 19, 2012.

AUTHORITY NOTE: Promulgated in accordance with R.S. 36:254 and Title XIX of the Social Security Act.

HISTORICAL NOTE: Promulgated by the Department of Health and Hospitals, Bureau of Health Services Financing, amended LR 36:1251 (June 2010), LR 38:

Implementation of the provisions of this Rule may be contingent upon the approval of the U.S. Department of Health and Human Services, Centers for Medicare and Medicaid Services (CMS), if it is determined that submission to CMS for review and approval is required.

Interested persons may submit written comments to J. Ruth Kennedy, Bureau of Health Services Financing, P.O. Box 91030, Baton Rouge, LA 70821-9030. She is responsible for responding to inquiries regarding this Emergency Rule. A copy of this Emergency Rule is available for review by interested parties at parish Medicaid offices.

Bruce D. Greenstein
Secretary

1210#098

DECLARATION OF EMERGENCY

Department of Health and Hospitals
Bureau of Health Services Financing

Professional Services Program
Family Planning Services
Reimbursement Rate Reduction
(LAC 50:IX.15143)

The Department of Health and Hospitals, Bureau of Health Services Financing amends LAC 50:IX.15143 in the Medical Assistance Program as authorized by R.S. 36:254 and pursuant to Title XIX of the Social Security Act and as directed by House Bill 1 of the 2012 Regular Session of the Louisiana Legislature which states: "The secretary is directed to utilize various cost containment measures to ensure expenditures remain at the level appropriated in this Schedule, including but not limited to precertification, preadmission screening, diversion, fraud control, utilization review and management, prior authorization, service limitations, drug therapy management, disease management, cost sharing, and other measures as permitted under federal law." This Emergency Rule is promulgated in accordance with the provisions of the Administrative Procedure Act, R.S. 49:953(B)(1) et seq., and shall be in effect for the maximum period allowed under the Act or until adoption of the final Rule, whichever occurs first.

As a result of a budgetary shortfall in state fiscal year 2010, the Department of Health and Hospitals, Bureau of Health Services Financing amended the provisions governing the Professional Services Program to reduce the reimbursement rates for family planning services and to promulgate these provisions in a codified format for inclusion in the *Louisiana Administrative Code (Louisiana Register, Volume 36, Number 11)*.

Due to a budgetary shortfall in state fiscal year 2013, the department promulgated an Emergency Rule which amended the provisions governing the reimbursement methodology for family planning services to reduce the reimbursement rates (*Louisiana Register, Volume 38, Number 7*). This Emergency Rule is being promulgated to continue the provisions of the July 1, 2012 Emergency Rule. This action is being taken to avoid a budget deficit in the medical assistance programs.

Effective October 30, 2012, the Department of Health and Hospitals, Bureau of Health Services Financing amends the provisions governing the Professional Services Program to reduce the reimbursement rates paid for family planning services.

Title 50
PUBLIC HEALTH—MEDICAL ASSISTANCE
Part IX. Professional Services Program
Subpart 15. Reimbursement
Chapter 151. Reimbursement Methodology
Subchapter E. Family Planning Services
§15143. Reimbursement

A. - C. ...

D. Effective for dates of service on or after July 1, 2012, the reimbursement rates for family planning services

rendered by a physician shall be reduced by 3.7 percent of the rates in effect on June 30, 2012.

AUTHORITY NOTE: Promulgated in accordance with R.S. 36:254 and Title XIX of the Social Security Act.

HISTORICAL NOTE: Promulgated by the Department of Health and Hospitals, Bureau of Health Services Financing, LR 36:2566 (November 2010), amended LR 38:

Implementation of the provisions of this Rule may be contingent upon the approval of the U.S. Department of Health and Human Services, Centers for Medicare and Medicaid Services (CMS), if it is determined that submission to CMS for review and approval is required.

Interested persons may submit written comments to J. Ruth Kennedy, Bureau of Health Services Financing, P.O. Box 91030, Baton Rouge, LA 70821-9030. She is responsible for responding to inquiries regarding this Emergency Rule. A copy of this Emergency Rule is available for review by interested parties at parish Medicaid offices.

Bruce D. Greenstein
Secretary

1210#099

DECLARATION OF EMERGENCY

Department of Health and Hospitals Bureau of Health Services Financing

Professional Services Program—Physician Services Reclassification of Optometry Services (LAC 50:IX.15111 and 15113)

Editor's Note: This Emergency Rule, which was initially published in the September 20, 2012 *Louisiana Register* on page 2337, is being republished in its entirety to correct the Section numbers in the headings of the Rule. No changes have been made to the language of the Emergency Rule.

The Department of Health and Hospitals, Bureau of Health Services Financing repeals the February 1982, January 1987, February 1987, and April 1987 Rules governing optometry services, and amends LAC 50:IX.15111 and §15113 in the Medical Assistance Program as authorized by R.S. 36:254 and pursuant to Title XIX of the Social Security Act. This Emergency Rule is promulgated in accordance with the provisions of the Administrative Procedure Act, R.S. 49:953(B)(1) et seq., and shall be in effect for the maximum period allowed under the Act or until adoption of the final Rule, whichever occurs first.

The Department of Health and Hospitals, Bureau of Health Services Financing provides Medicaid reimbursement for optometry services as an optional covered service under the Medicaid State Plan. Optometrists are classified in the Medicaid State Plan as other licensed practitioners and their services are not considered mandatory physician services.

The American Recovery and Reinvestment Act (ARRA) of 2009 authorized 100 percent federal financial participation to states for the purpose of establishing incentive payments to encourage Medicaid health care providers to adopt, implement, and use certified electronic health records (EHR) technology. The Act does not provide for incentive payments to optometrist unless the services

rendered by these practitioners are classified as mandatory physician services under the Medicaid State Plan.

Since the department already provides Medicaid reimbursement to participating optometrist to the same extent as physicians who perform the same eye care services, the decision has been made to amend the provisions governing physician services in the Professional Services Program in order to reclassify optometry services as a mandatory physician service under the Medicaid State Plan. This reclassification will allow optometrists to qualify for EHR incentive payments. The department also repeals the February 1982, January 1987, February 1987, and April 1987 Rules governing optometry services, and revises and repromulgates the June 1985 Rule in a codified format for inclusion in the *Louisiana Administrative Code*.

This action is being taken to secure new and enhanced federal funding, and to expand provider participation in the EHR Incentive Payment Program. It is anticipated that the implementation of this Emergency Rule will be cost neutral to the Medicaid Program for fiscal year 2012-2013 as incentive payments to qualifying optometrists shall be 100 percent federally funded.

Effective October 1, 2012, the Department of Health and Hospitals, Bureau of Health Services Financing amends the provisions governing physician services covered in the Professional Services Program.

Title 50

PUBLIC HEALTH—MEDICAL ASSISTANCE

Part IX. Professional Services Program

Subpart 15. Reimbursement

Chapter 151. Reimbursement Methodology

Subchapter B. Physician Services

§15111. General Provisions

A. The reimbursement rates for physician services shall be a flat fee for each covered service as specified on the established Medicaid fee schedule. The reimbursement rates shall be based on a percentage of the Louisiana Medicare Region 99 allowable for a specified year.

B. Optometry Services

1. Effective October 1, 2012, eye care services rendered by a participating optometrist, within their scope of optometric practice, shall be classified and reimbursed under the Medicaid State Plan as a mandatory physician service to the same extent, and according to the same standards as physicians who perform the same eye care services.

2. Recipients in the Early and Periodic Screening, Diagnosis and Treatment (EPSDT) Program are excluded from optometry service limits.

3. The Medicaid Program shall not provide reimbursement for eyeglasses provided to Medicaid recipients 21 years of age or older.

AUTHORITY NOTE: Promulgated in accordance with R.S. 36:254 and Title XIX of the Social Security Act.

HISTORICAL NOTE: Promulgated by the Department of Health and Hospitals, Bureau of Health Services Financing, LR 38:

§15113. Reimbursement

A. Effective for dates of service on or after October 15, 2007, the reimbursement for selected physician services shall be 90 percent of the 2007 Louisiana Medicare Region 99 allowable or billed charges, whichever is the lesser amount, unless otherwise stipulated.

1. The reimbursement shall remain the same for those services that are currently being reimbursed at a rate that is between 90 percent and 120 percent of the 2007 Louisiana Medicare Region 99 allowable.

2. For those services that are currently reimbursed at a rate above 120 percent of the 2007 Louisiana Medicare Region 99 allowable, effective for dates of service on or after October 15, 2007, the reimbursement for these services shall be reduced to 120 percent of the 2007 Louisiana Medicare Region 99 allowable.

B. Effective for dates of service on or after January 1, 2008, the reimbursement for selected physician services shall be 90 percent of the 2008 Louisiana Medicare Region 99 allowable or billed charges, whichever is the lesser amount, unless otherwise stipulated.

1. The reimbursement shall remain the same for those services that are currently being reimbursed at a rate that is between 90 percent and 120 percent of the 2008 Louisiana Medicare Region 99 allowable.

2. For those services that are currently reimbursed at a rate above 120 percent of the 2008 Louisiana Medicare Region 99 allowable, effective for dates of service on or after January 1, 2008, the reimbursement for these services shall be reduced to 120 percent of the 2008 Louisiana Medicare Region 99 allowable.

C. Effective for dates of service on or after August 4, 2009, the reimbursement for all physician services rendered to recipients 16 years of age or older shall be reduced to 80 percent of the 2009 Louisiana Medicare Region 99 allowable or billed charges, whichever is the lesser amount.

1. For those services that are currently reimbursed at a rate below 80 percent of the Louisiana Medicare Region 99 allowable, effective for dates of service on or after August 4, 2009, the reimbursement for these services shall be increased to 80 percent of the Louisiana Medicare Region 99 allowable or billed charges, whichever is the lesser amount.

2. The following physician services are excluded from the rate adjustment:

- a. preventive medicine evaluation and management;
- b. immunizations;
- c. family planning services; and
- d. select orthopedic reparative services.

3. Effective for dates of service on or after November 20, 2009, the following physician services are excluded from the rate adjustment:

- a. prenatal evaluation and management; and
- b. delivery services.

D. Effective for dates of service on or after January 22, 2010, physician services rendered to recipients 16 years of age or older shall be reduced to 75 percent of the 2009 Louisiana Medicare Region 99 allowable or billed charges, whichever is the lesser amount.

1. The following physician services rendered to recipients 16 years of age or older shall be reimbursed at 80 percent of the 2009 Louisiana Medicare Region 99 allowable or billed charges, whichever is the lesser amount:

- a. prenatal evaluation and management services;
- b. preventive medicine evaluation and management services; and
- c. obstetrical delivery services.

E. Effective for dates of service on or after January 22, 2010, all physician services rendered to recipients under the

age of 16 shall be reimbursed at 90 percent of the 2009 Louisiana Medicare Region 99 allowable or billed charges, whichever is the lesser amount.

F. Effective for dates of service on or after January 22, 2010, all physician-administered drugs shall be reimbursed at 90 percent of the 2009 Louisiana Medicare Average Sales Price (ASP) allowable or billed charges, whichever is the lesser amount.

G. Effective for dates of service on or after January 22, 2010, all physician services that are currently reimbursed below the reimbursement rates in §15113.E-G shall be increased to the rates in §15113.E-G.

H. Effective for dates of service on or after December 1, 2010, reimbursement shall be 90 percent of the 2009 Louisiana Medicare Region 99 allowable for the following obstetric services when rendered to recipients 16 years of age and older:

1. vaginal-only delivery (with or without postpartum care);
2. vaginal delivery after previous cesarean (VBAC) delivery; and
3. cesarean delivery following attempted vaginal delivery after previous cesarean delivery. The reimbursement for a cesarean delivery remains at 80 percent of the 2009 Louisiana Medicare Region 99 allowable when the service is rendered to recipients 16 years of age and older.

AUTHORITY NOTE: Promulgated in accordance with R.S. 36:254 and Title XIX of the Social Security Act.

HISTORICAL NOTE: Promulgated by the Department of Health and Hospitals, Bureau of Health Services Financing, LR 36:1252 (June 2010), amended LR 36:2282 (October 2010), amended LR 37:904 (March 2011), LR 38:

Implementation of the provisions of this Rule may be contingent upon the approval of the U.S. Department of Health and Human Services, Centers for Medicare and Medicaid Services (CMS), if it is determined that submission to CMS for review and approval is required.

Interested persons may submit written comments to J. Ruth Kennedy, Bureau of Health Services Financing, P.O. Box 91030, Baton Rouge, LA 70821-9030. She is responsible for responding to all inquiries regarding this Emergency Rule. A copy of this Emergency Rule is available for review by interested parties at parish Medicaid offices.

Bruce D. Greenstein
Secretary

1210#050

DECLARATION OF EMERGENCY

Department of Health and Hospitals Bureau of Health Services Financing

Professional Services Program—Physician Services
Reimbursement Rate Reduction (LAC 50:IX.15113)

The Department of Health and Hospitals, Bureau of Health Services Financing amends LAC 50:IX.15113 in the Medical Assistance Program as authorized by R.S. 36:254 and pursuant to Title XIX of the Social Security Act and as directed by House Bill 1 of the 2012 Regular Session of the Louisiana Legislature which states: “The secretary is

directed to utilize various cost containment measures to ensure expenditures remain at the level appropriated in this Schedule, including but not limited to precertification, preadmission screening, diversion, fraud control, utilization review and management, prior authorization, service limitations, drug therapy management, disease management, cost sharing, and other measures as permitted under federal law.” This Emergency Rule is promulgated in accordance with the provisions of the Administrative Procedure Act, R.S. 49:953(B)(1) et seq., and shall be in effect for the maximum period allowed under the Act or until adoption of the final Rule, whichever occurs first.

The Department of Health and Hospitals, Bureau of Health Services Financing amended the provisions governing the reimbursement methodology for physician services to increase the reimbursement rates for obstetric delivery services (*Louisiana Register*, Volume 37, Number 3).

As a result of a budgetary shortfall in state fiscal year 2013, the department promulgated an Emergency Rule which amended the provisions governing the reimbursement methodology for physician services to reduce the reimbursement rates and discontinue reimbursement for certain procedures (*Louisiana Register*, Volume 38, Number 7). The department has now determined that it is necessary to amend the provisions of the July 1, 2012 Emergency Rule in order to revise the formatting to ensure that these provisions are promulgated in a clear and concise manner. This action is being taken to avoid a budget deficit in the medical assistance programs.

Effective October 20, 2012, the Department of Health and Hospitals, Bureau of Health Services Financing amends the provisions of the July 1, 2012 Emergency Rule governing the reimbursement methodology for physician services.

Title 50

PUBLIC HEALTH—MEDICAL ASSISTANCE

Part IX. Professional Services Program

Subpart 15. Reimbursement

Chapter 151. Reimbursement Methodology

Subchapter B. Physician Services

§15113. Reimbursement

A. - H.3. ...

1. Effective for dates of service on or after July 1, 2012, reimbursement shall be as follows for the designated physician services:

1. reimbursement for professional services procedure (consult) codes 99241-99245 and 99251-99255 shall be discontinued;

2. cesarean delivery fees (procedure codes 59514-59515) shall be reduced to equal corresponding vaginal delivery fees (procedure codes 59409-59410); and

3. reimbursement for all other professional services procedure codes, exclusive of Affordable Care Act primary care procedure codes, shall be reduced by 3.4 percent of the rates on file as of June 30, 2012.

AUTHORITY NOTE: Promulgated in accordance with R.S. 36:254 and Title XIX of the Social Security Act.

HISTORICAL NOTE: Promulgated by the Department of Health and Hospitals, Bureau of Health Services Financing, LR 36:1252 (June 2010), amended LR 36:2282 (October 2010), amended LR 37:904 (March 2011), LR 38:

Implementation of the provisions of this Rule may be contingent upon the approval of the U.S. Department of Health and Human Services, Centers for Medicare and Medicaid Services (CMS), if it is determined that submission to CMS for review and approval is required.

Interested persons may submit written comments to J. Ruth Kennedy, Bureau of Health Services Financing, P.O. Box 91030, Baton Rouge, LA 70821-9030. She is responsible for responding to inquiries regarding this Emergency Rule. A copy of this Emergency Rule is available for review by interested parties at parish Medicaid offices.

Bruce D. Greenstein
Secretary

1210#051

DECLARATION OF EMERGENCY

Department of Health and Hospitals Bureau of Health Services Financing

Prosthetics and Orthotics
Reimbursement Rate Reduction
(LAC 50:XVII.501)

The Department of Health and Hospitals, Bureau of Health Services Financing amends LAC 50:XVII.501 in the Medical Assistance Program as authorized by R.S. 36:254 and pursuant to Title XIX of the Social Security Act and as directed by House Bill 1 of the 2012 Regular Session of the Louisiana Legislature which states: “The secretary is directed to utilize various cost containment measures to ensure expenditures remain at the level appropriated in this Schedule, including but not limited to precertification, preadmission screening, diversion, fraud control, utilization review and management, prior authorization, service limitations, drug therapy management, disease management, cost sharing, and other measures as permitted under federal law.” This Emergency Rule is promulgated in accordance with the provisions of the Administrative Procedure Act, R.S. 49:953(B)(1) et seq., and shall be in effect for the maximum period allowed under the Act or until adoption of the final Rule, whichever occurs first.

As a result of a budgetary shortfall in state fiscal year 2010, the Department of Health and Hospitals, Bureau of Health Services Financing amended the provisions governing the reimbursement methodology for prosthetics and orthotics to reduce the reimbursement rates (*Louisiana Register*, Volume 36, Number 11).

As a result of a budgetary shortfall in state fiscal year 2013, the department promulgated an Emergency Rule which amended the provisions governing the reimbursement methodology for prosthetics and orthotics to reduce the reimbursement rates (*Louisiana Register*, Volume 38, Number 7). This Emergency Rule is being promulgated to continue the provisions of the July 1, 2012 Emergency Rule. This action is being taken to avoid a budget deficit in the medical assistance programs.

Effective October 30, 2012, the Department of Health and Hospitals, Bureau of Health Services Financing amends the provisions governing the reimbursement methodology for prosthetics and orthotics to reduce reimbursement rates.

Title 50
PUBLIC HEALTH—MEDICAL ASSISTANCE
Part XVII. Prosthetics and Orthotics
Subpart 1. General Provisions

Chapter 5. Reimbursement

§501. Reimbursement Methodology

A. - F.1. ...

G. Effective for dates of service on or after July 1, 2012, the reimbursement for prosthetic and orthotic devices shall be reduced by 3.7 percent of the fee amounts on file as of June 30, 2012.

1. The rate reduction shall not apply to items that do not appear on the fee schedule and are individually priced.

AUTHORITY NOTE: Promulgated in accordance with R. S. 36:254 and Title XIX of the Social Security Act.

HISTORICAL NOTE: Promulgated by the Department of Health and Hospitals, Office of the Secretary, Bureau of Health Services Financing, LR 31:1597 (July 2005), amended LR 34:881 (May 2008), amended by the Department of Health and Hospitals, Bureau of Health Services Financing, LR 35:1903 (September 2009), repromulgated LR 36:521 (March 2010), amended LR 36:1253 (June 2010), amended LR 36:2567 (November 2010), LR 38:

Implementation of the provisions of this Rule may be contingent upon the approval of the U.S. Department of Health and Human Services, Centers for Medicare and Medicaid Services (CMS), if it is determined that submission to CMS for review and approval is required.

Interested persons may submit written comments to J. Ruth Kennedy, Bureau of Health Services Financing, P.O. Box 91030, Baton Rouge, LA 70821-9030. She is responsible for responding to inquiries regarding this Emergency Rule. A copy of this Emergency Rule is available for review by interested parties at parish Medicaid offices.

Bruce D. Greenstein
Secretary

1210#100

DECLARATION OF EMERGENCY

Department of Health and Hospitals
Bureau of Health Services Financing
and
Office of Behavioral Health

Substance Abuse Services
Reimbursement Rate Reduction
(LAC 50:XXXIII.14701)

The Department of Health and Hospitals, Bureau of Health Services Financing and the Office of Behavioral Health amend LAC 50:XXXIII.14701 in the Medical Assistance Program as authorized by R.S. 36:254 and pursuant to Title XIX of the Social Security Act and as directed by House Bill 1 of the 2012 Regular Session of the Louisiana Legislature which states: "The secretary is directed to utilize various cost containment measures to ensure expenditures remain at the level appropriated in this Schedule, including but not limited to precertification, preadmission screening, diversion, fraud control, utilization review and management, prior authorization, service

limitations, drug therapy management, disease management, cost sharing, and other measures as permitted under federal law." This Emergency Rule is promulgated in accordance with the provisions of the Administrative Procedure Act, R.S. 49:953(B)(1) et seq., and shall be in effect for the maximum period allowed under the Act or until adoption of the final Rule, whichever occurs first.

The Department of Health and Hospitals, Bureau of Health Services Financing adopted provisions to implement a coordinated behavioral health services system under the Medicaid Program which provides coverage of substance abuse services for children and adults (*Louisiana Register*, Volume 38, Number 2).

As a result of a budgetary shortfall in state fiscal year 2013, the department promulgated an Emergency Rule which amended the provisions governing the reimbursement methodology for substance abuse services to reduce the reimbursement rates for outpatient substance abuse services provided to children/adolescents (*Louisiana Register*, Volume 38, Number 7). This Emergency Rule is being promulgated to continue the provisions of the July 1, 2012 Emergency Rule. This action is being taken to avoid a budget deficit in the medical assistance programs.

Effective October 30, 2012, the Department of Health and Hospitals, Bureau of Health Services Financing and the Office of Behavioral Health amend the provisions governing the reimbursement methodology for substance abuse services to reduce the reimbursement rates.

Title 50
PUBLIC HEALTH-MEDICAL ASSISTANCE
Part XXXIII. Behavioral Health Services
Subpart 15. Substance Abuse Services

Chapter 147. Reimbursement

§14701. Reimbursement Methodology

A. ...

B. Effective for dates of service on or after July 1, 2012, the reimbursement rates for outpatient substance abuse services provided to children/adolescents shall be reduced by 1.44 percent of the rates in effect on June 30, 2012.

AUTHORITY NOTE: Promulgated in accordance with R.S. 36:254 and Title XIX of the Social Security Act.

HISTORICAL NOTE: Promulgated by the Department of Health and Hospitals, Bureau of Health Services Financing and the Office of Behavioral Health, LR 38:427 (February 2012), amended LR 38:

Implementation of the provisions of this Rule may be contingent upon the approval of the U.S. Department of Health and Human Services, Centers for Medicare and Medicaid Services (CMS), if it is determined that submission to CMS for review and approval is required.

Interested persons may submit written comments to J. Ruth Kennedy, Bureau of Health Services Financing, P.O. Box 91030, Baton Rouge, LA 70821-9030. She is responsible for responding to inquiries regarding this Emergency Rule. A copy of this Emergency Rule is available for review by interested parties at parish Medicaid offices.

Bruce D. Greenstein
Secretary

1210#101

DECLARATION OF EMERGENCY

Department of Health and Hospitals Bureau of Health Services Financing

Targeted Case Management Reimbursement Rate Reduction (LAC 50:XV.10701)

The Department of Health and Hospitals, Bureau of Health Services Financing amends LAC 50:XV.10701 in the Medical Assistance Program as authorized by R.S. 36:254 and pursuant to Title XIX of the Social Security Act and as directed by House Bill 1 of the 2012 Regular Session of the Louisiana Legislature which states: "The secretary is directed to utilize various cost containment measures to ensure expenditures remain at the level appropriated in this Schedule, including but not limited to precertification, preadmission screening, diversion, fraud control, utilization review and management, prior authorization, service limitations, drug therapy management, disease management, cost sharing, and other measures as permitted under federal law." This Emergency Rule is promulgated in accordance with the provisions of the Administrative Procedure Act, R.S. 49:953(B)(1) et seq., and shall be in effect for the maximum period allowed under the Act.

The Department of Health and Hospitals, Bureau of Health Services Financing amended the provisions governing the reimbursement methodology for targeted case management services (TCM) to reduce the reimbursement rates paid for TCM services provided in the Nurse Family Partnership (NFP) Program and to restrict reimbursement of TCM services in the NFP Program to prenatal and postnatal services only (*Louisiana Register*, Volume 36, Number 8).

As a result of a budgetary shortfall in state fiscal year 2013, the Department of Health and Hospitals, Bureau of Health Services Financing promulgated an Emergency Rule which amended the provisions governing the reimbursement methodology for TCM services to reduce the reimbursement rates (*Louisiana Register*, Volume 38, Number 7). This Emergency Rule is being promulgated to continue the provisions of the July 1, 2012 Emergency Rule. This action is being taken to avoid a budget deficit in the medical assistance programs.

Effective October 30, 2012, the Department of Health and Hospitals, Bureau of Health Services Financing amends the provisions governing the reimbursement methodology for targeted case management services to reduce the reimbursement rates.

Title 50

PUBLIC HEALTH—MEDICAL ASSISTANCE

Part XV. Services for Special Populations

Subpart 7. Targeted Case Management

Chapter 107. Reimbursement

§10701. Reimbursement

A. - F.1. ...

G. Effective for dates of service on or after July 1, 2012, the reimbursement for case management services provided to the following targeted populations shall be reduced by 1.5 percent of the rates on file as of June 30, 2012:

1. participants in the Nurse Family Partnership Program;

2. participants in the Early and Periodic Screening, Diagnosis, and Treatment Program;

3. individuals diagnosed with HIV; and

4. individuals with developmental disabilities who participate in the New Opportunities Waiver.

AUTHORITY NOTE: Promulgated in accordance with R.S. 36:254 and Title XIX of the Social Security Act.

HISTORICAL NOTE: Promulgated by the Department of Health and Hospitals, Office of the Secretary, Bureau of Health Services Financing, LR 30:1040 (May 2004), amended LR 31:2032 (August 2005), amended LR 35:73 (January 2009), amended by the Department of Health and Hospitals, Bureau of Health Services Financing, LR 35:1903 (September 2009), amended LR 36:1783 (August 2010), LR 38:

Implementation of the provisions of this Rule may be contingent upon the approval of the U.S. Department of Health and Human Services, Centers for Medicare and Medicaid Services (CMS), if it is determined that submission to CMS for review and approval is required.

Interested persons may submit written comments to J. Ruth Kennedy, Bureau of Health Services Financing, P.O. Box 91030, Baton Rouge, LA 70821-9030. She is responsible for responding to inquiries regarding this Emergency Rule. A copy of this Emergency Rule is available for review by interested parties at parish Medicaid offices.

Bruce D. Greenstein
Secretary

1210#102

DECLARATION OF EMERGENCY

Department of Health and Hospitals Bureau of Health Services Financing and Office of Public Health

Uncompensated Care Payments (LAC 50:I.Chapter 13)

The Department of Health and Hospitals, Bureau of Health Services Financing and the Office of Public Health adopt LAC 50:I.Chapter 13 in the Medical Assistance Program as authorized by R.S. 36:254 and pursuant to Title XIX of the Social Security Act. This Emergency Rule is promulgated in accordance with the provisions of the Administrative Procedure Act, R.S. 49:953(B)(1) et seq., and shall be in effect for the maximum period allowed under the Act or until adoption of the final Rule, whichever occurs first.

The Department of Health and Hospitals, Bureau of Health Services Financing and the Office of Public Health (OPH) promulgated an Emergency Rule which adopted provisions to establish Medicaid payment of uncompensated care costs for services rendered by OPH to Medicaid eligible recipients (*Louisiana Register*, Volume 38, Number 7). The Office of Public Health shall certify public expenditures to the Medicaid Program as a means of financing in order for the Medicaid Program to secure federal funding for OPH's uncompensated care costs of providing services to Medicaid recipients. This Emergency Rule is being promulgated to continue the provisions of the July 1, 2012 Emergency Rule. This action is being taken to secure new federal funding and to promote the public health and welfare of Medicaid

recipients by ensuring continued access to primary care and clinic services provided by OPH.

Effective October 30, 2012, the Department of Health and Hospitals, Bureau of Health Services Financing and the Office of Public Health adopt provisions governing the reimbursement of uncompensated care costs for services rendered by the Office of Public Health.

Title 50

PUBLIC HEALTH—MEDICAL ASSISTANCE

Part I. Administration

Subpart 1. General Provisions

Chapter 13. Office of Public Health Uncompensated Care Payments

§1301. General Provisions

A. Effective for dates of service on or after July 1, 2012, the department shall provide the Office of Public Health (OPH) with Medicaid payment of their uncompensated care costs for services rendered to Medicaid recipients.

B. The Office of Public Health shall certify public expenditures to the Medicaid Program in order to secure federal funding for services provided at the cost of OPH. The following services shall qualify for Medicaid reimbursement under these provisions:

1. family planning services;
2. sexually transmitted diseases (STDs);
3. tuberculosis;
4. children's special health services (CSHS);
5. laboratory services;
6. newborn screening;
7. nurse family partnership;
8. maternity services; and
9. child health.

AUTHORITY NOTE: Promulgated in accordance with R.S. 36:254 and Title XIX of the Social Security Act.

HISTORICAL NOTE: Promulgated by the Department of Health and Hospitals, Bureau of Health Services Financing and the Office of Public Health, LR 38:

§1303. Payment Methodology

A. The OPH will submit an estimate of costs for the Medicaid-covered services provided. The estimated costs will be calculated based on the previous state fiscal year's (July 1-June 30) expenditures and reduced by the estimate of payments made for services to OPH for the fiscal year. The difference between estimated costs and estimated interim payments will be referred to as the net uncompensated care cost. The net uncompensated care cost will be reported on a quarterly basis on the CMS Form 64.

B. Upon completion of the fiscal year, the OPH shall submit a cost report which will be used as a settlement of cost within one year of the end of the fiscal year.

C. Any adjustments to the net uncompensated care cost for a fiscal year will be reported on the CMS Form 64 as a prior period adjustment in the quarter of settlement.

AUTHORITY NOTE: Promulgated in accordance with R.S. 36:254 and Title XIX of the Social Security Act.

HISTORICAL NOTE: Promulgated by the Department of Health and Hospitals, Bureau of Health Services Financing and the Office of Public Health, LR 38:

Implementation of the provisions of this Rule may be contingent upon the approval of the U.S. Department of Health and Human Services, Centers for Medicare and Medicaid Services (CMS), if it is determined that submission to CMS for review and approval is required.

Interested persons may submit written comments to J. Ruth Kennedy, Bureau of Health Services Financing, P.O. Box 91030, Baton Rouge, LA 70821-9030. She is responsible for responding to inquiries regarding this Emergency Rule. A copy of this Emergency Rule is available for review by interested parties at parish Medicaid offices.

Bruce D. Greenstein
Secretary

1210#092

DECLARATION OF EMERGENCY

Department of Health and Hospitals Licensed Professional Vocational Rehabilitation Counselors Board of Examiners

Practice of Mental Health Counseling for
Serious Mental Illnesses (LAC 46:LX.505)

The Louisiana Department of Health and Hospitals, Louisiana Licensed Professional Counselors Board of Examiners has exercised the emergency provisions of the Administrative Procedures Act, specifically R.S. 49:953(B), to adopt rules relative to the Practice of Mental Health Counseling, to be designated as Section 505 of board rules. Previously, an Emergency Rule designated as Section 505 of board rules was promulgated due to Act 320 of the 2011 Regular Legislative Session. This Emergency Rule replaces the previously promulgated Emergency Rule due to Act 636 of the 2012 Regular Legislative Session. This Emergency Rule is effective November 1, 2012 for a period of 120 days. The Louisiana Licensed Professional Counselors Board of Examiners is in the process of developing the permanent Rule associated with Act 636 of the 2012 Regular Legislative Session.

This action is necessary due to the immediate effect of Act 636 of 2012, which defines duties for Louisiana Professional Counselors who treat "serious mental illnesses." Because Act 636 was effective on June 7, 2012 upon the Governor's signature, and because of the substantive changes made, there is insufficient time to promulgate these rules under the usual Administrative Procedures Act rulemaking process. However, it is the intent of the Louisiana Licensed Professional Counselors Board of Examiners to submit a Notice of Intent to adopt a permanent Rule as soon as possible in connection with the proposed adoption of Emergency Rules on this subject.

Title 46

PROFESSIONAL AND OCCUPATIONAL STANDARDS

Part LX. Licensed Professional Counselors Board of Examiners

Subpart 1. Licensed Professional Counselors Chapter 5. License and Practice of Counseling §505. Serious Mental Illnesses

A. Introduction. Act 636 of the 2012 Regular Session of the Louisiana Legislative amended the Louisiana Professional Counselors Practice Act as follows.

1. *Mental Health Counseling Services*—rendering or offering prevention, assessment, diagnosis, and treatment, which include psychotherapy, of mental, emotional, behavioral, and addiction disorders to individuals, groups,

organizations, or the general public by a licensed professional counselor, that is consistent with his professional training as prescribed by R.S. 37:1107(A)(8), and code of ethics/behavior involving the application of principles, methods, or procedures of the mental health counseling profession.

2. However, a LPC may not assess, diagnose, or provide treatment to any individual suffering from a serious mental illness when medication may be indicated, unless the LPC consults and collaborates with a practitioner who is licensed or holds a permit with the State Board of Medical Examiners or an advanced practice registered nurse licensed by the Louisiana State Board of Nursing who is certified as a psychiatric nurse practitioner.

B. Applicability. The requirement for collaboration and consultation set forth above shall apply only if any of the following conditions are assessed, diagnosed, or treated by the counselor:

1. schizophrenia or schizoaffective disorder;
2. bipolar disorder;
3. panic disorder;
4. obsessive-compulsive disorder;
5. major depressive disorder- moderate to severe;
6. anorexia/bulimia;
7. intermittent explosive disorder;
8. autism;
- 9 psychosis NOS (not otherwise specified) when diagnosed in a child under seventeen years of age;
10. Rett's disorder;
11. Tourette's disorder;
12. dementia.

C. Definitions

1. As used herein *practitioner*—an individual who is licensed or holds a permit with the State Board of Medical Examiners or an advanced practice registered nurse licensed by the Louisiana State Board of Nursing who is certified as a psychiatric nurse practitioner.

2. As used herein *medication is indicated when*—the client has been diagnosed with a serious mental illness and:

- a. when the client or legal guardian discloses the prescribed use of psychiatric medication, and/or
- b. when the LPC, client, or legal guardian believes that the use of prescribed psychiatric medication may facilitate treatment goals and improve client functioning.

3. As used herein *consultation and collaboration*—when medication is indicated for clients who have been diagnosed with a serious mental illness, the counselor shall initiate contact with a practitioner for the purpose of communicating the diagnosis and plan of care. The counselor will provide information to the practitioner regarding client progress as conditions warrant. Consultation and collaboration, for purposes of these rules and otherwise, shall not be construed as supervision. Further, consultation and collaboration does not include the transfer between the consulting professionals of responsibility for the client's care or the ongoing management of the client's presenting problem(s).

D. Effect on Existing Rules. All existing rules or parts thereof are hereby superseded and amended to the extent that they specifically conflict with these emergency rules. Existing board rules shall be revised and re-codified at such

time as the final board rules implementing Act 636 are adopted.

AUTHORITY NOTE: Promulgated in accordance with R.S. 37:1105(D).

HISTORICAL NOTE: Promulgated by the Department of Health and Hospitals, Louisiana Licensed Professional Counselors Board of Examiners, LR 38:

Mary Alice Olsan
Executive Director

1210#024

DECLARATION OF EMERGENCY

Department of Health and Hospitals Office of Public Health

Review and Approval of Plans and Specifications for Issuance of a Permit for a Potable Water Supply (LAC 51:XII.105)

The state health officer, acting through the Department of Health and Hospitals, Office of Public Health (DHH-OPH), pursuant to the rulemaking authority granted by R.S. 40:4(A)(8) and (13), hereby adopts the following emergency rule to prevent an imminent peril to the public welfare. This rule is being promulgated in accordance with the Administrative Procedure Act (R.S.49:950, et seq.).

The state health officer, through DHH/OPH, finds it necessary to promulgate an Emergency Rule effective September 20, 2012. This Emergency Rule is scheduled to terminate 120 days from September, 20, 2012. A Notice of Intent (NOI) was published in the December 20, 2011 issue of the Louisiana Register which proposed, among other items, to amend LAC 51:XII.105.D. In a meeting held on Thursday, September 6, 2012, the agency was asked and agreed to retract the LAC 51:XII.105.D amending portion of the NOI, which takes effect on September 20, 2012. Therefore, the agency hereby enacts this Emergency Rule to negate the change to LAC 51:XII.105.D made by the described NOI. This combination will allow DHH/OPH to adopt several state-equivalent rules which are necessary for the agency to maintain its primacy designation from the United State Environmental Protection Agency (USEPA); therefore, assuring the continuance of federal grant funds for the Louisiana Safe Drinking Water Program.

In the respect that the Emergency Rule will extend into January 2013, the agency is to form a committee in the interim with the persons who had concerns with the proposed language to work out any changes deemed necessary to LAC 51:XII.105.D.

Title 51

PUBLIC HEALTH—SANITARY CODE

Part XII. Water Supplies

Chapter 1. General

§105. Permit Requirements for a Potable Water Supply

[formerly paragraph 12:002-2]

A. - C. ...

D. The review and approval of plans and specifications submitted for issuance of a permit, will be made in accordance with the "Ten-State Standards" and the *Louisiana Water Well Rules, Regulations, and Standards*

(LAC 56:I), plus any additional requirements of the state health officer as set forth in this Part.

AUTHORITY NOTE: Promulgated in accordance with R.S. 40:4 (A)(8) and R.S. 40:5 (5)(6)(7)(17)(19).

HISTORICAL NOTE: Promulgated by the Department of Health and Hospitals, Office of Public Health, LR 28:1320 (June 2002), amended LR 38:

Bruce D Greenstein
Secretary

1210#002

DECLARATION OF EMERGENCY

Department of Natural Resources Office of Conservation

Statewide Orders No. 29-B and 29-B-A—Deadline of Drilling and Completion Operational and Safety Requirements for Wells Drilled in Search or for the Production of Oil or Natural Gas at Water Locations

Pursuant to the power delegated under the laws of the state of Louisiana, and particularly Title 30 of the Revised Statutes of 1950, as amended, and in conformity with the provisions of the Louisiana Administrative Procedure Act, Title 49, Sections 953(B)(1) and (2), 954(B)(2), as amended, the following Emergency Rule and reasons therefore are now adopted and promulgated by the commissioner of conservation as being necessary to protect the public health, safety and welfare of the people of the state of Louisiana, as well as the environment generally, by extending the effectiveness of the Emergency Rule it supersedes for drilling and completion operational and safety requirements for wells drilled in search of oil and natural gas at water locations. The following Emergency Rule provides for the extension of the Rule allowing more time to complete comprehensive rule amendments.

Need and Purpose for Emergency Rule

In light of the Gulf of Mexico Deepwater Horizon oil spill incident in federal waters approximately 50 miles off Louisiana's coast and the threat posed to the natural resources of the state, and the economic livelihood and property of the citizens of the state caused thereby, the Office of Conservation began a new review of its current drilling and completion operational and safety requirements for wells drilled in search of oil and natural gas at water locations. While the incidents of blowout of Louisiana wells is minimal, occurring at less than three-tenths of one percent of the wells drilled in Louisiana since 1987, the great risk posed by blowouts at water locations to the public health, safety and welfare of the people of the state, as well as the environment generally, necessitated the rule amendments contained herein.

After implementation of the Emergency Rule, Conservation formed an ad hoc committee to further study comprehensive rulemaking in order to promulgate new permanent regulations which ensure increased operational and safety requirements for the drilling or completion of oil and gas wells at water locations within the state. Based upon the work of this ad hoc committee, draft proposed rules that would replace these Emergency Rules are being created for the consideration and comment by interested parties.

Synopsis

The Emergency Rule set forth hereinafter is intended to provide greater protection to the public health, safety and welfare of the people of the state, as well as the environment generally by extending the effectiveness of new operational and safety requirements for the drilling and completion of oil and gas wells at water locations. Following the Gulf of Mexico-Deepwater Horizon oil spill, the Office of Conservation ("Conservation") investigated the possible expansion of Statewide Orders No. 29-B and 29-B-a requirements relating to well control at water locations. As part of the rule expansion project, Conservation reviewed the well control regulations of the U.S. Department of the Interior's Mineral Management Service or MMS (now named the Bureau of Safety and Environmental Enforcement). Except in the instances where it was determined that the MMS provisions were repetitive of other provisions already being incorporated, were duplicative of existing Conservation regulations or were not applicable to the situations encountered in Louisiana's waters, all provisions of the MMS regulations concerning well control issues at water locations were promulgated in the preceding Emergency Rules, which this Rule supersedes, were integrated into Conservation's Statewide Orders No. 29-B and 29-B-a.

Conservation is currently performing a comprehensive review of its regulations as it considers future amendments to its operational rules and regulations found in Statewide Order No. 29-B and elsewhere. Specifically, the Emergency Rule extends the effectiveness of a new Chapter within Statewide Order No. 29-B (LAC 43:XIX.Chapter 2) to provide additional rules concerning the drilling and completion of oil and gas wells at water locations, specifically providing for the following: rig movement and reporting requirements, additional requirements for applications to drill, casing program requirements, mandatory diverter systems and blowout preventer requirements, oil and gas well-workover operations, diesel engine safety requirements, and drilling fluid regulations. Further, the Emergency Rule amends Statewide Order No. 29-B-a (LAC 43:XIX.Chapter 11) to provide for and expand upon rules concerning the required use of storm chokes in oil and gas wells at water locations.

Reasons

Recognizing the potential advantages of expanding the operational and safety requirements for the drilling and completion of oil and gas wells at water locations within the state, it has been determined that failure to establish such requirements in the form of an administrative rule may lead to the existence of an imminent peril to the public health, safety and welfare of the people of the state of Louisiana, as well as the environment generally. By this Rule Conservation extends the effectiveness of the following requirements until such time as final comprehensive rules may be promulgated or 120 days from the effective date of this Rule, whichever occurs first.

Protection of the public and our environment therefore requires the commissioner of conservation to extend the following rules in order to assure that drilling and completion of oil and gas wells at water locations within the state are undertaken in accordance with all reasonable care and protection to the health, safety of the public, oil and gas

personnel and the environment generally. The Emergency Rule, Amendment to Statewide Order No. 29-B (LAC 43:XIX.Chapter 2) and Statewide Order No. 29-B-a (LAC 43:XIX.Chapter 11) (Emergency Rule) set forth hereinafter are adopted and extended by the Office of Conservation.

The Emergency Rule signed by the commissioner on May 23, 2012 and effective May 23, 2012 is hereby rescinded and replaced by the following Emergency Rule.

Effective Date and Duration

The effective date for this Emergency Rule shall be September 21, 2012.

The Emergency Rule herein adopted as a part thereof, shall remain effective for a period of not less than 120 days hereafter, or until the adoption of the final version of an amendment to Statewide Order No. 29-B and Statewide Order No. 29-B-a as noted herein, whichever occurs first.

Title 43

NATURAL RESOURCES

Part XIX. Office of Conservation—General Operations

Subpart 1. Statewide Order No. 29-B

Chapter 2. Additional Requirements for Water

Locations

§201. Applicability

A. In addition to the requirements set forth in Chapter 1 of this Subpart, all oil and gas wells being drilled or completed at a water location within the state shall comply with this Chapter.

B. Unless otherwise stated herein, nothing within this Chapter shall alter the obligation of oil and gas operators to meet the requirements of Chapter 1 of this Subpart.

AUTHORITY NOTE: Promulgated in accordance with R.S. 30:4 et seq.

HISTORICAL NOTE: Promulgated by the Department of Natural Resources, Office of Conservation, LR 38:

§203. Application to Drill

A. In addition to the requirements set forth in Section 103 of this Subpart, at the time of submittal of an application for permit to drill, the applicant will provide an electronic copy on a disk of the spill prevention control (SPC) plan that was submitted to DEQ pursuant to the provisions of Part IX of Title 33 of the Louisiana Administrative Code or any successor Rule. Such plan shall become a part of the official well file.

AUTHORITY NOTE: Promulgated in accordance with R.S. 30:4 et seq.

HISTORICAL NOTE: Promulgated by the Department of Natural Resources, Office of Conservation, LR 38:

§204. Rig Movement and Reporting

A. The operator must report the movement of all drilling and workover rig units on and off locations to the appropriate district manager with the rig name, well serial number and expected time of arrival and departure.

B. Drilling operations on a platform with producing wells or other hydrocarbon flow must comply with the following.

1. An emergency shutdown station must be installed near the driller's console.

2. All producible wells located in the affected wellbay must be shut in below the surface and at the wellhead when:

a. a rig or related equipment is moved on and off a platform. This includes rigging up and rigging down activities within 500 feet of the affected platform;

b. a drilling unit is moved or skid between wells on a platform;

c. a mobile offshore drilling unit (MODU) moves within 500 feet of a platform.

3. Production may be resumed once the MODU is in place, secured, and ready to begin drilling operations.

C. The movement of rigs and related equipment on and off a platform or from well to well on the same platform, including rigging up and rigging down, shall be conducted in a safe manner. All wells in the same well-bay which are capable of producing hydrocarbons shall be shut in below the surface with a pump-through-type tubing plug and at the surface with a closed master valve prior to moving well-completion rigs and related equipment, unless otherwise approved by the district manager. A closed surface-controlled subsurface safety valve of the pump-through type may be used in lieu of the pump-through-type tubing plug, provided that the surface control has been locked out of operation. The well from which the rig or related equipment is to be moved shall also be equipped with a back-pressure valve prior to removing the blowout preventer (BOP) system and installing the tree.

AUTHORITY NOTE: Promulgated in accordance with R.S. 30:4 et seq.

HISTORICAL NOTE: Promulgated by the Department of Natural Resources, Office of Conservation, LR 38:

§205. Casing Program

A. General Requirements

1. The operator shall case and cement all wells with a sufficient number of strings of casing and quantity and quality of cement in a manner necessary to prevent fluid migration in the wellbore, protect the underground source of drinking water (USDW) from contamination, support unconsolidated sediments, and otherwise provide a means of control of the formation pressures and fluids.

2. The operator shall install casing necessary to withstand collapse, bursting, tensile, and other stresses that may be encountered and the well shall be cemented in a manner which will anchor and support the casing. Safety factors in casing program design shall be of sufficient magnitude to provide optimum well control while drilling and to assure safe operations for the life of the well.

3. All tubulars and cement shall meet or exceed API standards. Cementing jobs shall be designed so that cement composition, placement techniques, and waiting times ensure that the cement placed behind the bottom 500 feet of casing attains a minimum compressive strength of 500 psi before drilling out of the casing or before commencing completion operations.

4. Centralizers

a. Surface casing shall be centralized by means of placing centralizers in the following manner:

i. a centralizer shall be placed on every third joint from the shoe to surface, with two centralizers being placed on each of the lowermost three joints of casing;

ii. if conductor pipe is set, three centralizers shall be equally spaced on surface casing to fall within the conductor pipe.

b. Intermediate and production casing, and drilling and production liners shall be centralized by means of a centralizer placed every third joint from the shoe to top of cement. Additionally, two centralizers shall be placed on each of the lowermost three joints of casing.

c. All centralizers shall meet API standards.

5. A copy of the documentation furnished by the manufacturer, if new, or supplier, if reconditioned, which certifies tubular condition, shall be provided with the well history and work resume report (Form WH-1).

B. Conductor Pipe. A conductor pipe is that pipe ordinarily used for the purpose of supporting unconsolidated surface deposits. A conductor pipe shall be used during the drilling of any oil and gas well and shall be set at depth that allows use of a diverter system.

C. Surface Casing

1. Where no danger of pollution of the USDW exists, the minimum amount of surface or first-intermediate casing to be set shall be determined from Table 1 hereof, except that in no case shall less surface casing be set than an amount needed to protect the USDW unless an alternative method of USDW protection is approved by the district manager.

Total Depth of Contact	Casing Required	Surface Casing Test Pressure (lbs. per sq. in.)
0-2500	100	300
2500-3000	150	600
3000-4000	300	600
4000-5000	400	600
5000-6000	500	750
6000-7000	800	1000
7000-8000	1000	1000
8000-9000	1400	1000
9000-Deeper	1800	1000

a. In known low-pressure areas, exceptions to the above may be granted by the commissioner or his agent. If, however, in the opinion of the commissioner, or his agent, the above regulations shall be found inadequate, and additional or lesser amount of surface casing and/or test pressure shall be required for the purpose of safety and the protection of the USDW.

2. Surface casing shall be cemented with a sufficient volume of cement to insure cement returns to the surface.

3. Surface casing shall be tested before drilling the plug by applying a minimum pump pressure as set forth in Table 1 after at least 200 feet of the mud-laden fluid has been displaced with water at the top of the column. If at the end of 30 minutes the pressure gauge shows a drop of 10 percent of test pressure as outlined in Table 1, the operator shall be required to take such corrective measures as will insure that such surface casing will hold said pressure for 30 minutes without a drop of more than 10 percent of the test pressure. The provisions of Paragraph E.7, below, for the producing casing, shall also apply to the surface casing.

4. Cement shall be allowed to stand a minimum of 12 hours under pressure before initiating test or drilling plug. Under pressure is complied with if one float valve is used or if pressure is held otherwise.

D. Intermediate Casing/Drilling Liner

1. Intermediate casing is that casing used as protection against caving of heaving formations or when other means are not adequate for the purpose of segregating upper oil, gas or water-bearing strata. Intermediate casing/drilling liner shall be set when required by abnormal pressure or other well conditions.

2. If an intermediate casing string is deemed necessary by the district manager for the prevention of underground waste, such regulations pertaining to a minimum setting depth, quality of casing, and cementing and testing of sand, shall be determined by the Office of Conservation after due hearing. The provisions of Paragraph E.7 below, for the producing casing, shall also apply to the intermediate casing.

3. Intermediate casing/drilling liner shall be at minimum, cemented in such a manner, at least 500 feet above all known hydrocarbon bearing formations to insure isolation and, if applicable, all abnormal pressure formations are isolated from normal pressure formations, but in no case shall less cement be used than the amount necessary to fill the casing/liner annulus to a point 500 feet above the shoe or the top of the liner whichever is less. If a liner is used as an intermediate string, the cement shall be tested by a fluid entry test (-0.5 ppg EMW) to determine whether a seal between the liner top and next larger casing string has been achieved, and the liner-lap point must be at least 300 feet above the previous casing shoe. The drilling liner (and liner-lap) shall be tested to a pressure at least equal to the anticipated pressure to which the liner will be subjected to during the formation-integrity test below that liner shoe, or subsequent liner shoes if set. Testing shall be in accordance with Subsection G below.

4. Before drilling the plug in the intermediate string of casing, the casing shall be tested by pump pressure, as determined from Table 2 hereof, after 200 feet of mud-laden fluid in the casing has been displaced by water at the top of the column.

Depth Set	Test Pressure (lbs. per sq. in.)
2000-3000'	800
3000-6000'	1000
6000-9000'	1200
9000-and deeper	1500

a. If at the end of 30 minutes the pressure gauge shows a drop of 10 percent of the test pressure or more, the operator shall be required to take such corrective measures as will insure that casing is so set and cemented that it will hold said pressure for 30 minutes without a drop of more than 10 percent of the test pressure on the gauge.

5. Cement shall be allowed to stand a minimum of 12 hours under pressure and a minimum total of 24 hours before initiating pressure test. Under pressure is complied with if one or more float valves are employed and are shown to be holding the cement in place, or when other means of holding pressure is used. When an operator elects to perforate and squeeze or to cement around the shoe, he may proceed with such work after 12 hours have elapsed after placing the first cement.

6. If the test is unsatisfactory, the operator shall not proceed with the drilling of the well until a satisfactory test has been obtained.

E. Producing String

1. Producing string, production casing or production liner is that casing used for the purpose of segregating the horizon from which production is obtained and affording a means of communication between such horizons and the surface.

2. The producing string of casing shall consist of new or reconditioned casing, tested at mill test pressure or as otherwise designated by the Office of Conservation.

3. Cement shall be by the pump-and-plug method, or another method approved by the Office of Conservation. Production casing/production liner shall be at minimum, cemented in such a manner, at least 500 feet above all known hydrocarbon bearing formations to insure isolation and, if applicable, all abnormal pressure formations are isolated from normal pressure formations, but in no case shall less cement be used than the amount necessary to fill the casing/liner annulus to a point 500 feet above the shoe or the top of the liner whichever is less. If a liner is used as a producing string, the cement shall be tested by a fluid entry test (-0.5 ppg EMW) to determine whether a seal between the liner top and next larger casing string has been achieved, and the liner-lap point must be at least 300 feet above the previous casing shoe. The production liner (and liner-lap) shall be tested to a pressure at least equal to the anticipated pressure to which the liner will be subjected to during the formation-integrity test below that liner shoe, or subsequent liner shoes if set. Testing shall be in accordance with Subsection G below.

4. The amount of cement to be left remaining in the casing, until the requirements of Paragraph 5 below have been met, shall be not less than 20 feet. This shall be accomplished through the use of a float-collar, or other approved or practicable means, unless a full-hole cementer, or its equivalent, is used.

5. Cement shall be allowed to stand a minimum of 12 hours under pressure and a minimum total of 24 hours before initiating pressure test in the producing or oil string. Under pressure is complied with if one or more float valves are employed and are shown to be holding the cement in place, or when other means of holding pressure is used. When an operator elects to perforate and squeeze or to cement around the shoe, he may proceed with such work after 12 hours have elapsed after placing the first cement.

6. Before drilling the plug in the producing string of casing, the casing shall be tested by pump pressure, as determined from Table 3 hereof, after 200 feet of mud-laden fluid in the casing has been displaced by water at the top of the column.

Depth Set	Test Pressure (lbs. per sq. in.)
2000-3000'	800
3000-6000'	1000
6000-9000'	1200
9000-and deeper	1500

a. If at the end of 30 minutes the pressure gauge shows a drop of 10 percent of the test pressure or more, the operator shall be required to take such corrective measures as will insure that the producing string of casing is so set and cemented that it will hold said pressure for 30 minutes without a drop of more than 10 percent of the test pressure on the gauge.

7. If the commissioner's agent is not present at the time designated by the operator for inspection of the casing tests of the producing string, the operator shall have such

tests witnessed, preferably by an offset operator. An affidavit of test, on the form prescribed by the district office, signed by the operator and witness, shall be furnished to the district office showing that the test conformed satisfactorily to the above mentioned regulations before proceeding with the completion. If test is satisfactory, normal operations may be resumed immediately.

8. If the test is unsatisfactory, the operator shall not proceed with the completion of the well until a satisfactory test has been obtained.

F. Cement Evaluation

1. Cement evaluation tests (cement bond or temperature survey) shall be conducted for all casing and liners installed below surface casing to assure compliance with LAC 43:XIX.205.D.3 and E.3.

2. Remedial cementing operations that are required to achieve compliance with LAC 43:XIX.205.D.3 and E.3 shall be conducted following receipt of an approved work permit from the district manager for the proposed operations.

3. Cementing and wireline records demonstrating the presence of the required cement tops shall be retained by the operator for a period of two years.

G. Leak-Off Tests

1. A pressure integrity test must be conducted below the surface casing or liner and all intermediate casings or liners. The district manager may require a pressure-integrity test at the conductor casing shoe if warranted by local geologic conditions or the planned casing setting depth. Each pressure integrity test must be conducted after drilling at least 10 feet but no more than 50 feet of new hole below the casing shoe and must be tested to either the formation leak-off pressure or to the anticipated equivalent drilling fluid weight at the setting depth of the next casing string.

a. The pressure integrity test and related hole-behavior observations, such as pore-pressure test results, gas-cut drilling fluid, and well kicks must be used to adjust the drilling fluid program and the setting depth of the next casing string. All test results must be recorded and hole-behavior observations made during the course of drilling related to formation integrity and pore pressure in the driller's report.

b. While drilling, a safe drilling margin must be maintained. When this safe margin cannot be maintained, drilling operations must be suspended until the situation is remedied.

H. Prolonged Drilling Operations

1. If wellbore operations continue for more than 30 days within a casing string run to the surface:

a. drilling operations must be stopped as soon as practicable, and the effects of the prolonged operations on continued drilling operations and the life of the well evaluated. At a minimum, the operator shall:

- i. caliper or pressure test the casing; and
- ii. report evaluation results to the district manager and obtain approval of those results before resuming operations.

b. If casing integrity as determined by the evaluation has deteriorated to a level below minimum safety factors, the casing must be repaired or another casing string run. Approval from the district manager shall be obtained prior to any casing repair activity.

I. Tubing and Completion

1. Well-completion operations means the work conducted to establish the production of a well after the production-casing string has been set, cemented, and pressure-tested.

2. Prior to engaging in well-completion operations, crew members shall be instructed in the safety requirements of the operations to be performed, possible hazards to be encountered, and general safety considerations to protect personnel, equipment, and the environment. Date and time of safety meetings shall be recorded and available for review by the office of conservation.

3. When well-completion operations are conducted on a platform where there are other hydrocarbon-producing wells or other hydrocarbon flow, an emergency shutdown system (ESD) manually controlled station shall be installed near the driller's console or well-servicing unit operator's work station.

4. No tubing string shall be placed in service or continue to be used unless such tubing string has the necessary strength and pressure integrity and is otherwise suitable for its intended use.

5. A valve, or its equivalent, tested to a pressure of not less than the calculated bottomhole pressure of the well, shall be installed below any and all tubing outlet connections.

6. When a well develops a casing pressure, upon completion, equivalent to more than three-quarters of the internal pressure that will develop the minimum yield point of the casing, such well shall be required by the district manager to be killed, and a tubing packer to be set so as to keep such excessive pressure off of the casing.

7. Wellhead Connections. Wellhead connections shall be tested prior to installation at a pressure indicated by the district manager in conformance with conditions existing in areas in which they are used. Whenever such tests are made in the field, they shall be witnessed by an agent of the office of conservation. Tubing and tubingheads shall be free from obstructions in wells used for bottomhole pressure test purposes.

8. When the tree is installed, the wellhead shall be equipped so that all annuli can be monitored for sustained pressure. If sustained casing pressure is observed on a well, the Operator shall immediately notify the district manager.

9. Wellhead, tree, and related equipment shall have a pressure rating greater than the shut-in tubing pressure and shall be designed, installed, used, maintained, and tested so as to achieve and maintain pressure control. New wells completed as flowing or gas-lift wells shall be equipped with a minimum of one master valve and one surface safety valve, installed above the master valve, in the vertical run of the tree.

AUTHORITY NOTE: Promulgated in accordance with R.S. 30:4 et seq.

HISTORICAL NOTE: Promulgated by the Department of Natural Resources, Office of Conservation, LR 38:

§207. Diverter Systems and Blowout Preventers

A. Diverter System. A diverter system shall be required when drilling surface hole in areas where drilling hazards are known or anticipated to exist. The district manager may, at his discretion, require the use of a diverter system on any well. In cases where it is required, a diverter system consisting of a diverter sealing element, diverter lines, and

control systems must be designed, installed, used, maintained, and tested to ensure proper diversion of gases, water, drilling fluids, and other materials away from facilities and personnel. The diverter system shall be designed to incorporate the following elements and characteristics:

1. dual diverter lines arranged to provide for maximum diversion capability;

2. at least two diverter control stations. One station shall be on the drilling floor. The other station shall be in a readily accessible location away from the drilling floor;

3. remote-controlled valves in the diverter lines. All valves in the diverter system shall be full-opening. Installation of manual or butterfly valves in any part of the diverter system is prohibited;

4. minimize the number of turns in the diverter lines, maximize the radius of curvature of turns, and minimize or eliminate all right angles and sharp turns;

5. anchor and support systems to prevent whipping and vibration;

6. rigid piping for diverter lines. The use of flexible hoses with integral end couplings in lieu of rigid piping for diverter lines shall be approved by the district manager.

B. Diverter Testing Requirements

1. When the diverter system is installed, the diverter components including the sealing element, diverter valves, control systems, stations and vent lines shall be function and pressure tested.

2. For drilling operations with a surface wellhead configuration, the system shall be function tested at least once every 24-hour period after the initial test.

3. After nipping-up on conductor casing, the diverter sealing element and diverter valves are to be pressure tested to a minimum of 200 psig. Subsequent pressure tests are to be conducted within seven days after the previous test.

4. Function tests and pressure tests shall be alternated between control stations.

5. Recordkeeping Requirements

a. Pressure and function tests are to be recorded in the driller's report and certified (signed and dated) by the operator's representative.

b. The control station used during a function or pressure test is to be recorded in the driller's report.

c. Problems or irregularities during the tests are to be recorded along with actions taken to remedy same in the driller's report.

d. All reports pertaining to diverter function and/or pressure tests are to be retained for inspection at the wellsite for the duration of drilling operations.

C. BOP Systems. The operator shall specify and insure that contractors design, install, use, maintain and test the BOP system to ensure well control during drilling, workover and all other appropriate operations. The surface BOP stack shall be installed before drilling below surface casing.

1. BOP system components for drilling activity located over a body of water shall be designed and utilized, as necessary, to control the well under all potential conditions that might occur during the operations being conducted and at minimum, shall include the following components:

a. annular-type well control component;

b. hydraulically-operated blind rams;

- c. hydraulically-operated shear rams;
- d. two sets of hydraulically-operated pipe rams.

2. Drilling activity with a tapered drill string shall require the installation of two or more sets of conventional or variable-bore pipe rams in the BOP stack to provide, at minimum, two sets of rams capable of sealing around the larger-size drill string and one set of pipe rams capable of sealing around the smaller-size drill string.

3. A set of hydraulically-operated combination rams may be used for the blind rams and shear rams.

4. All connections used in the surface BOP system must be flanged, including the connections between the well control stack and the first full-opening valve on the choke line and the kill line.

5. The commissioner of conservation, following a public hearing, may grant exceptions to the requirements of LAC 43:XIX.207.C-J.

D. BOP Working Pressure. The working pressure rating of any BOP component, excluding annular-type preventers, shall exceed the maximum anticipated surface pressure (MASP) to which it may be subjected.

E. BOP Auxiliary Equipment. All BOP systems shall be equipped and provided with the following.

1. A hydraulically actuated accumulator system which shall provide 1.5 times volume of fluid capacity to close and hold closed all BOP components, with a minimum pressure of 200 psig above the pre-charge pressure without assistance from a charging system.

2. A backup to the primary accumulator-charging system, supplied by a power source independent from the power source to the primary, which shall be sufficient to close all BOP components and hold them closed.

3. Accumulator regulators supplied by rig air without a secondary source of pneumatic supply shall be equipped with manual overrides or other devices to ensure capability of hydraulic operation if the rig air is lost.

4. At least one operable remote BOP control station in addition to the one on the drilling floor. This control station shall be in a readily accessible location away from the drilling floor. If a BOP control station does not perform properly, operations shall be suspended until that station is operable.

5. A drilling spool with side outlets, if side outlets are not provided in the body of the BOP stack, to provide for separate kill and choke lines.

6. A kill line and a separate choke line are required. Each line must be equipped with two full-opening valves and at least one of the valves must be remotely controlled. The choke line shall be installed above the bottom ram. A manual valve must be used instead of the remotely controlled valve on the kill line if a check valve is installed between the two full-opening manual valves and the pump or manifold. The valves must have a working pressure rating equal to or greater than the working pressure rating of the connection to which they are attached, and must be installed between the well control stack and the choke or kill line. For operations with expected surface pressures greater than 3,500 psi, the kill line must be connected to a pump or manifold. The kill line inlet on the BOP stack must not be used for taking fluid returns from the wellbore.

7. A valve installed below the swivel (upper kelly cock), essentially full-opening, and a similar valve installed

at the bottom of the kelly (lower kelly cock). An operator must be able to strip the lower kelly cock through the BOP stack. A wrench to fit each valve shall be stored in a location readily accessible to the drilling crew. If drilling with a mud motor and utilizing drill pipe in lieu of a kelly, you must install one kelly valve above, and one strippable kelly valve below the joint of pipe used in place of a kelly. On a top-drive system equipped with a remote-controlled valve, you must install a strippable kelly-type valve below the remote-controlled valve.

8. An essentially full-opening drill-string safety valve in the open position on the rig floor shall be available at all times while drilling operations are being conducted. This valve shall be maintained on the rig floor to fit all connections that are in the drill string. A wrench to fit the drill-string safety valve shall be stored in a location readily accessible to the drilling crew.

9. A safety valve shall be available on the rig floor assembled with the proper connection to fit the casing string being run in the hole.

10. Locking devices installed on the ram-type preventers.

F. BOP Maintenance and Testing Requirements

1. The BOP system shall be visually inspected on a daily basis.

2. Pressure tests (low and high pressure) of the BOP system are to be conducted at the following times and intervals:

a. during a shop test prior to transport of the BOPs to the drilling location. Shop tests are not required for equipment that is transported directly from one well location to another;

b. immediately following installation of the BOPs;

c. within 14 days of the previous BOP pressure test, alternating between control stations and at a staggered interval to allow each crew to operate the equipment. If either control system is not functional, further operations shall be suspended until the nonfunctional, system is operable. Exceptions may be granted by the district manager in cases where a trip is scheduled to occur within 2 days after the 14-day testing deadline;

d. before drilling out each string of casing or liner (The district manager may require that a conservation enforcement specialist witness the test prior to drilling out each casing string or liner);

e. not more than 48 hours before a well is drilled to a depth that is within 1000 feet of a hydrogen sulfide zone (The district manager may require that a conservation enforcement specialist witness the test prior to drilling to a depth that is within 1000 feet of a hydrogen sulfide zone);

f. when the BOP tests are postponed due to well control problem(s), the BOP test is to be performed on the first trip out of the hole, and reasons for postponing the testing are to be recorded in the driller's report.

3. Low pressure tests (200-300 psig) of the BOP system (choke manifold, kelly valves, drill-string safety valves, etc.) are to be performed at the times and intervals specified in LAC 43:XIX.207.F.2. in accordance with the following provisions.

a. Test pressures are to be held for a minimum of five minutes.

b. Variable bore pipe rams are to be tested against the largest and smallest sizes of pipe in use, excluding drill collars and bottom hole assembly.

c. Bonnet seals are to be tested before running the casing when casing rams are installed in the BOP stack.

4. High pressure tests of the BOP system are to be performed at the times and intervals specified in LAC 43:XIX.207.F.2 in accordance with the following provisions.

a. Test pressures are to be held for a minimum of five minutes.

b. Ram-type BOP's, choke manifolds, and associated equipment are to be tested to the rated working pressure of the equipment or 500 psi greater than the calculated MASP for the applicable section of the hole.

c. Annular-type BOPs are to be tested to 70 percent of the rated working pressure of the equipment.

5. The annular and ram-type BOPs with the exception of the blind-shear rams are to be function tested every seven days between pressure tests. All BOP test records should be certified (signed and dated) by the operator's representative.

a. Blind-shear rams are to be tested at all casing points and at an interval not to exceed 30 days.

6. If the BOP equipment does not hold the required pressure during a test, the problem must be remedied and a retest of the affected component(s) performed. Additional BOP testing requirements:

a. use water to test the surface BOP system;

b. if a control station is not functional operations shall be suspended until that station is operable;

c. test affected BOP components following the disconnection or repair of any well-pressure containment seal in the wellhead or BOP stack assembly.

G. BOP Record Keeping. The time, date and results of pressure tests, function tests, and inspections of the BOP system are to be recorded in the driller's report. All pressure tests shall be recorded on an analog chart or digital recorder. All documents are to be retained for inspection at the wellsite for the duration of drilling operations and are to be retained in the operator's files for a period of 2 years.

H. BOP Well Control Drills. Weekly well control drills with each drilling crew are to be conducted during a period of activity that minimizes the risk to drilling operations. The drills must cover a range of drilling operations, including drilling with a diverter (if applicable), on-bottom drilling, and tripping. Each drill must be recorded in the driller's report and is to include the time required to close the BOP system, as well as, the total time to complete the entire drill.

I. Well Control Safety Training. In order to ensure that all drilling personnel understand and can properly perform their duties prior to drilling wells which are subject to the jurisdiction of the Office of Conservation, the operator shall require that contract drilling companies provide and/or implement the following:

1. periodic training for drilling contractor employees which ensures that employees maintain an understanding of, and competency in, well control practices;

2. procedures to verify adequate retention of the knowledge and skills that the contract drilling employees need to perform their assigned well control duties.

J. Well Control Operations

1. The Operator must take necessary precautions to keep wells under control at all times and must:

a. use the best available and safest drilling technology to monitor and evaluate well conditions and to minimize the potential for the well to flow or kick;

b. have a person onsite during drilling operations who represents the operators interests and can fulfill the operators responsibilities;

c. ensure that the tool pusher, operator's representative, or a member of the drilling crew maintains continuous surveillance on the rig floor from the beginning of drilling operations until the well is completed or abandoned, unless you have secured the well with blowout preventers (BOPs), bridge plugs, cement plugs, or packers;

d. use and maintain equipment and materials necessary to ensure the safety and protection of personnel, equipment, natural resources, and the environment.

2. Whenever drilling operations are interrupted, a downhole safety device must be installed, such as a cement plug, bridge plug, or packer. The device must be installed at an appropriate depth within a properly cemented casing string or liner.

a. Among the events that may cause interruption to drilling operations are:

i. evacuation of the drilling crew;

ii. inability to keep the drilling rig on location; or

iii. repair to major drilling or well-control equipment.

3. If the diverter or BOP stack is nipped down while waiting on cement, it must be determined, before nipping down, when it will be safe to do so based on knowledge of formation conditions, cement composition, effects of nipping down, presence of potential drilling hazards, well conditions during drilling, cementing, and post cementing, as well as past experience.

AUTHORITY NOTE: Promulgated in accordance with R.S. 30:4 et seq.

HISTORICAL NOTE: Promulgated by the Department of Natural Resources, Office of Conservation, LR 38:

§209. Casing-Heads

A. All wells shall be equipped with casing-heads with a test pressure in conformance with conditions existing in areas in which they are used. Casing-head body, as soon as installed shall be equipped with proper connections and valves accessible to the surface. Reconditioning shall be required on any well showing pressure on the casing-head, or leaking gas or oil between the oil string and next larger size casing string, when, in the opinion of the district managers, such pressure or leakage assume hazardous proportions or indicate the existence of underground waste. Mud-laden fluid may be pumped between any two strings of casing at the top of the hole, but no cement shall be used except by special permission of the commissioner or his agent.

AUTHORITY NOTE: Promulgated in accordance with R.S. 30:4 et seq.

HISTORICAL NOTE: Promulgated by the Department of Natural Resources, Office of Conservation, LR 38:

§211. Oil and Gas Well-Workover Operations

A. Definitions. When used in this section, the following terms shall have the meanings given below.

Expected Surface Pressure—the highest pressure predicted to be exerted upon the surface of a well. In calculating expected surface pressure, reservoir pressure as well as applied surface pressure must be considered.

Routine Operations—any of the following operations conducted on a well with the tree installed including cutting paraffin, removing and setting pump-through-type tubing plugs, gas-lift valves, and subsurface safety valves which can be removed by wireline operations, bailing sand, pressure surveys, swabbing, scale or corrosion treatment, caliper and gauge surveys, corrosion inhibitor treatment, removing or replacing subsurface pumps, through-tubing logging, wireline fishing, and setting and retrieving other subsurface flow-control devices.

Workover Operations—the work conducted on wells after the initial completion for the purpose of maintaining or restoring the productivity of a well.

B. When well-workover operations are conducted on a well with the tree removed, an emergency shutdown system (ESD) manually controlled station shall be installed near the driller's console or well-servicing unit operator's work station, except when there is no other hydrocarbon-producing well or other hydrocarbon flow on the platform.

C. Prior to engaging in well-workover operations, crew members shall be instructed in the safety requirements of the operations to be performed, possible hazards to be encountered, and general safety considerations to protect personnel, equipment, and the environment. Date and time of safety meetings shall be recorded and available for review.

D. Well-Control Fluids, Equipment, and Operations. The following requirements apply during all well-workover operations with the tree removed.

1. The minimum BOP-system components when the expected surface pressure is less than or equal to 5,000 psi shall include one annular-type well control component, one set of pipe rams, and one set of blind-shear rams.

2. The minimum BOP-system components when the expected surface pressure is greater than 5,000 psi shall include one annular-type well control component, two sets of pipe rams, and one set of blind-shear rams.

3. BOP auxiliary equipment in accordance with the requirements of LAC 43:XIX.207.E.

4. When coming out of the hole with drill pipe or a workover string, the annulus shall be filled with well-control fluid before the change in such fluid level decreases the hydrostatic pressure 75 pounds per square inch (psi) or every five stands of drill pipe or workover string, whichever gives a lower decrease in hydrostatic pressure. The number of stands of drill pipe or workover string and drill collars that may be pulled prior to filling the hole and the equivalent well-control fluid volume shall be calculated and posted near the operator's station. A mechanical, volumetric, or electronic device for measuring the amount of well-control fluid required to fill the hold shall be utilized.

5. The following well-control-fluid equipment shall be installed, maintained, and utilized:

- a. a fill-up line above the uppermost BOP;
- b. a well-control, fluid-volume measuring device for determining fluid volumes when filling the hole on trips; and
- c. a recording mud-pit-level indicator to determine mud-pit-volume gains and losses. This indicator shall include both a visual and an audible warning device.

E. The minimum BOP-system components for well-workover operations with the tree in place and performed

through the wellhead inside of conventional tubing using small-diameter jointed pipe (usually 3/4 inch to 1 1/4 inch) as a work string, i.e., small-tubing operations, shall include two sets of pipe rams, and one set of blind rams.

1. An essentially full-opening work-string safety valve in the open position on the rig floor shall be available at all times while well-workover operations are being conducted. This valve shall be maintained on the rig floor to fit all connections that are in the work string. A wrench to fit the work-string safety valve shall be stored in a location readily accessible to the workover crew.

F. For coiled tubing operations with the production tree in place, you must meet the following minimum requirements for the BOP system:

1. BOP system components must be in the following order from the top down when expected surface pressures are less than or equal to 3,500 psi:

- a. stripper or annular-type well control component;
- b. hydraulically-operated blind rams;
- c. hydraulically-operated shear rams;
- d. kill line inlet;
- e. hydraulically operated two-way slip rams;
- f. hydraulically operated pipe rams.

2. BOP system components must be in the following order from the top down when expected surface pressures are greater than 3,500 psi:

- a. stripper or annular-type well control component;
- b. hydraulically-operated blind rams;
- c. hydraulically-operated shear rams;
- d. kill line inlet;
- e. hydraulically-operated two-way slip rams;
- f. hydraulically-operated pipe rams;
- g. hydraulically-operated blind-shear rams. these

rams should be located as close to the tree as practical.

3. BOP system components must be in the following order from the top down for wells with returns taken through an outlet on the BOP stack:

- a. stripper or annular-type well control component;
- b. hydraulically-operated blind rams;
- c. hydraulically-operated shear rams;
- d. kill line inlet;
- e. hydraulically-operated two-way slip rams;
- f. hydraulically-operated pipe rams;
- g. a flow tee or cross;
- h. hydraulically-operated pipe rams;
- i. hydraulically-operated blind-shear rams on wells

with surface pressures less than or equal to 3,500 psi. As an option, the pipe rams can be placed below the blind-shear rams. The blind-shear rams should be placed as close to the tree as practical.

4. A set of hydraulically-operated combination rams may be used for the blind rams and shear rams.

5. A set of hydraulically-operated combination rams may be used for the hydraulic two-way slip rams and the hydraulically-operated pipe rams.

6. A dual check valve assembly must be attached to the coiled tubing connector at the downhole end of the coiled tubing string for all coiled tubing well-workover operations. To conduct operations without a downhole check valve, it must be approved by the district manager.

7. A kill line and a separate choke line are required. Each line must be equipped with two full-opening valves

and at least one of the valves must be remotely controlled. A manual valve must be used instead of the remotely controlled valve on the kill line if a check valve is installed between the two full-opening manual valves and the pump or manifold. The valves must have a working pressure rating equal to or greater than the working pressure rating of the connection to which they are attached, and must be installed between the well control stack and the choke or kill line. For operations with expected surface pressures greater than 3,500 psi, the kill line must be connected to a pump or manifold. The kill line inlet on the BOP stack must not be used for taking fluid returns from the wellbore.

8. The hydraulic-actuating system must provide sufficient accumulator capacity to close-open-close each component in the BOP stack. This cycle must be completed with at least 200 psi above the pre-charge pressure without assistance from a charging system.

9. All connections used in the surface BOP system from the tree to the uppermost required ram must be flanged, including the connections between the well control stack and the first full-opening valve on the choke line and the kill line.

10. The coiled tubing connector must be tested to a low pressure of 200 to 300 psi, followed by a high pressure test to the rated working pressure of the connector or the expected surface pressure, whichever is less. The dual check valves must be successfully pressure tested to the rated working pressure of the connector, the rated working pressure of the dual check valve, expected surface pressure, or the collapse pressure of the coiled tubing, whichever is less.

G. The minimum BOP-system components for well-workover operations with the tree in place and performed by moving tubing or drill pipe in or out of a well under pressure utilizing equipment specifically designed for that purpose, i.e., snubbing operations, shall include the following:

1. one set of pipe rams hydraulically operated; and
2. two sets of stripper-type pipe rams hydraulically operated with spacer spool.

H. Test pressures must be recorded during BOP and coiled tubing tests on a pressure chart, or with a digital recorder, unless otherwise approved by the district manager. The test interval for each BOP system component must be 5 minutes, except for coiled tubing operations, which must include a 10 minute high-pressure test for the coiled tubing string.

I. Wireline Operations. The operator shall comply with the following requirements during routine, as defined in Subsection A of this section, and nonroutine wireline workover operations:

1. Wireline operations shall be conducted so as to minimize leakage of well fluids. Any leakage that does occur shall be contained to prevent pollution.

2. All wireline perforating operations and all other wireline operations where communication exists between the completed hydrocarbon-bearing zone(s) and the wellbore shall use a lubricator assembly containing at least one wireline valve.

3. When the lubricator is initially installed on the well, it shall be successfully pressure tested to the expected shut-in surface pressure.

J. Following completion of the well-workover activity, all such records shall be retained by the Operator for a period of two years.

K. An essentially full-opening work-string safety valve in the open position on the rig floor shall be available at all times while well-workover operations are being conducted. This valve shall be maintained on the rig floor to fit all connections that are in the work string. A wrench to fit the work-string safety valve shall be stored in a location readily accessible to the workover crew.

AUTHORITY NOTE: Promulgated in accordance with R.S. 30:4 et seq.

HISTORICAL NOTE: Promulgated by the Department of Natural Resources, Office of Conservation, LR 38:

§213. Diesel Engine Safety Requirements

A. Each diesel engine with an air take device must be equipped to shut down the diesel engine in the event of a runaway.

1. A diesel engine that is not continuously manned, must be equipped with an automatic shutdown device.

2. A diesel engine that is continuously manned, may be equipped with either an automatic or remote manual air intake shutdown device.

3. A diesel engine does not have to be equipped with an air intake device if it meets one of the following criteria:

- a. starts a larger engine;
- b. powers a firewater pump;
- c. powers an emergency generator;
- d. powers a bop accumulator system;
- e. provides air supply to divers or confined entry personnel;
- f. powers temporary equipment on a nonproducing platform;
- g. powers an escape capsule; or
- h. powers a portable single-cylinder rig washer.

AUTHORITY NOTE: Promulgated in accordance with R.S. 30:4 et seq.

HISTORICAL NOTE: Promulgated by the Department of Natural Resources, Office of Conservation, LR 38:

§215. Drilling Fluids

A. The inspectors and engineers of the Office of Conservation shall have access to the mud records of any drilling well, except those records which pertain to special muds and special work with respect to patentable rights, and shall be allowed to conduct any essential test or tests on the mud used in the drilling of a well. When the conditions and tests indicate a need for a change in the mud or drilling fluid program in order to insure proper control of the well, the district manager shall require the operator or company to use due diligence in correcting any objectionable conditions.

B. Well-control fluids, equipment, and operations shall be designed, utilized, maintained, and/or tested as necessary to control the well in foreseeable conditions and circumstances.

C. The well shall be continuously monitored during all operations and shall not be left unattended at any time unless the well is shut in and secured.

D. The following well-control-fluid equipment shall be installed, maintained, and utilized:

1. a fill-up line above the uppermost bop;
2. a well-control, fluid-volume measuring device for determining fluid volumes when filling the hole on trips; and

3. a recording mud-pit-level indicator to determine mud-pit-volume gains and losses. This indicator shall include both a visual and an audible warning device.

E. Safe Practices

1. Before starting out of the hole with drill pipe, the drilling fluid must be properly conditioned. A volume of drilling fluid equal to the annular volume must be circulated with the drill pipe just off-bottom. This practice may be omitted if documentation in the driller's report shows:

a. no indication of formation fluid influx before starting to pull the drill pipe from the hole;

b. the weight of returning drilling fluid is within 0.2 pounds per gallon of the drilling fluid entering the hole.

2. Record each time drilling fluid is circulated in the hole in the driller's report.

3. When coming out of the hole with drill pipe, the annulus must be filled with drilling fluid before the hydrostatic pressure decreases by 75 psi, or every five stands of drill pipe, whichever gives a lower decrease in hydrostatic pressure. The number of stands of drill pipe and drill collars that you may pull must be calculated before you fill the hole. Both sets of numbers must be posted near the driller's station. A mechanical, volumetric, or electronic device must be used to measure the drilling fluid required to fill the hole.

4. Controlled rates must be used to run and pull drill pipe and downhole tools so you do not swab or surge the well.

5. When there is an indication of swabbing or influx of formation fluids, appropriate measures must be taken to control the well. Circulate and condition the well, on or near-bottom, unless well or drilling-fluid conditions prevent running the drill pipe back to the bottom.

6. The maximum pressures must be calculated and posted near the driller's console that you may safely contain under a shut-in BOP for each casing string. The pressures posted must consider the surface pressure at which the formation at the shoe would break down, the rated working pressure of the BOP stack, and 70 percent of casing burst (or casing test as approved by the district manager). As a minimum, you must post the following two pressures:

a. the surface pressure at which the shoe would break down. this calculation must consider the current drilling fluid weight in the hole; and

b. the lesser of the BOP's rated working pressure or 70 percent of casing-burst pressure (or casing test otherwise approved by the district manager).

7. An operable drilling fluid-gas separator and degasser must be installed before you begin drilling operations. This equipment must be maintained throughout the drilling of the well.

8. The test fluids in the hole must be circulated or reverse circulated before pulling drill-stem test tools from the hole. If circulating out test fluids is not feasible, with an appropriate kill weight fluid test fluids may be bullhead out of the drill-stem test string and tools.

9. When circulating, the drilling fluid must be tested at least once each work shift or more frequently if conditions warrant. The tests must conform to industry-accepted practices and include density, viscosity, and gel strength; hydrogen ion concentration; filtration; and any other tests the district manager requires for monitoring and maintaining drilling fluid quality, prevention of downhole equipment

problems and for kick detection. The test results must be recorded in the drilling fluid report.

F. Monitoring Drilling Fluids

1. Once drilling fluid returns are established, the following drilling fluid-system monitoring equipment must be installed throughout subsequent drilling operations. This equipment must have the following indicators on the rig floor:

a. pit level indicator to determine drilling fluid-pit volume gains and losses. This indicator must include both a visual and an audible warning device;

b. volume measuring device to accurately determine drilling fluid volumes required to fill the hole on trips;

c. return indicator devices that indicate the relationship between drilling fluid-return flow rate and pump discharge rate. This indicator must include both a visual and an audible warning device; and

d. gas-detecting equipment to monitor the drilling fluid returns. The indicator may be located in the drilling fluid-logging compartment or on the rig floor. If the indicators are only in the logging compartment, you must continually man the equipment and have a means of immediate communication with the rig floor. If the indicators are on the rig floor only, an audible alarm must be installed.

G. Drilling Fluid Quantities

1. Quantities of drilling fluid and drilling fluid materials must be maintained and replenished at the drill site as necessary to ensure well control. These quantities must be determined based on known or anticipated drilling conditions, rig storage capacity, weather conditions, and estimated time for delivery.

2. The daily inventories of drilling fluid and drilling fluid materials must be recorded, including weight materials and additives in the drilling fluid report.

3. If there are not sufficient quantities of drilling fluid and drilling fluid material to maintain well control, the drilling operations must be suspended.

H. Drilling Fluid-Handling Areas

1. Drilling fluid-handling areas must be classified according to API RP 500, Recommended Practice for Classification of Locations for Electrical Installations at Petroleum Facilities, Classified as Class I, Division 1 and Division 2 or API RP 505, Recommended Practice for Classification of Locations for Electrical Installations at Petroleum Facilities, Classified as Class 1, Zone 0, Zone 1, and Zone 2. In areas where dangerous concentrations of combustible gas may accumulate. A ventilation system and gas monitors must be installed and maintained. Drilling fluid-handling areas must have the following safety equipment:

a. a ventilation system capable of replacing the air once every 5 minutes or 1.0 cubic feet of air-volume flow per minute, per square foot of area, whichever is greater. In addition:

i. if natural means provide adequate ventilation, then a mechanical ventilation system is not necessary;

ii. if a mechanical system does not run continuously, then it must activate when gas detectors indicate the presence of 1 percent or more of combustible gas by volume; and

iii. if discharges from a mechanical ventilation system may be hazardous, the drilling fluid-handling area must be maintained at a negative pressure. The negative pressure area must be protected by using at least one of the following: a pressure-sensitive alarm, open-door alarms on each access to the area, automatic door-closing devices, air locks, or other devices approved by the district manager;

b. gas detectors and alarms except in open areas where adequate ventilation is provided by natural means. Gas detectors must be tested and recalibrated quarterly. No more than 90 days may elapse between tests;

c. explosion-proof or pressurized electrical equipment to prevent the ignition of explosive gases. Where air is used for pressuring equipment, the air intake must be located outside of and as far as practicable from hazardous areas; and

d. alarms that activate when the mechanical ventilation system fails.

AUTHORITY NOTE: Promulgated in accordance with R.S. 30:4 et seq.

HISTORICAL NOTE: Promulgated by the Department of Natural Resources, Office of Conservation, LR 38:

Subpart 4. Statewide Order No. 29-B-a

Chapter 11. Required Use of Storm Chokes

§1101. Scope

A. Order establishing rules and regulations concerning the required use of storm chokes to prevent blowouts or uncontrolled flow in the case of damage to surface equipment.

AUTHORITY NOTE: Promulgated in accordance with Act 157 of the Legislature of 1940.

HISTORICAL NOTE: Adopted by the Department of Conservation, March 15, 1946, amended March 1, 1961, amended and promulgated by the Department of Natural Resources, Office of Conservation, LR 20:1127 (October 1994), LR 38:

§1103. Applicability

A. All wells capable of flow with a surface pressure in excess of 100 pounds, falling within the following categories, shall be equipped with storm chokes.:

1. any locations inaccessible during periods of storm and/or floods, including spillways;

2. located in bodies of water being actively navigated;

3. located in wildlife refuges and/or game preserves;

4. located within 660 feet of railroads, ship channels, and other actively navigated bodies of water;

5. located within 660 feet of state and federal highways in Southeast Louisiana, in that area East of a North-South line drawn through New Iberia and South of an East-West line through Opelousas;

6. located within 660 feet of state and federal highways in Northeast Louisiana, in that area bounded on the West by the Ouachita River, on the North by the Arkansas-Louisiana line, on the East by the Mississippi River, and on the South by the Black and Red Rivers;

7. located within 660 feet of the following highways:

a. U.S. Highway 71 between Alexandria and Krotz Springs;

b. U.S. Highway 190 between Opelousas and Krotz Springs;

c. U.S. Highway 90 between Lake Charles and the Sabine River;

8. located within the corporate limits of any city, town, village, or other municipality.

AUTHORITY NOTE: Promulgated in accordance with Act 157 of the Legislature of 1940.

HISTORICAL NOTE: Adopted by the Department of Conservation, March 15, 1946, amended March 1, 1961, amended and promulgated by Department of Natural Resources, Office of Conservation, LR 20:1128 (October 1994), LR 38:

§1104. General Requirements for Storm Choke Use at Water Locations

A. This Section only applies to oil and gas wells at water locations.

B. A subsurface safety valve shall be designed, installed, used, maintained, and tested to ensure reliable operation.

1. The device shall be installed at a depth of 100 feet or more below the seafloor within 2 days after production is established.

2. Until a subsurface safety device is installed, the well shall be attended in the immediate vicinity so that emergency actions may be taken while the well is open to flow. During testing and inspection procedures, the well shall not be left unattended while open to production unless a properly operating subsurface-safety device has been installed in the well.

3. The well shall not be open to flow while the subsurface safety device is removed, except when flowing of the well is necessary for a particular operation such as cutting paraffin, bailing sand, or similar operations.

4. All SSSV's must be inspected, installed, used, maintained, and tested in accordance with American Petroleum Institute Recommended Practice 14B, Recommended Practice for Design, Installation, Repair, and Operation of Subsurface Safety Valve Systems.

C. Temporary Removal for Routine Operations.

1. Each wireline or pumpdown-retrievable subsurface safety device may be removed, without further authorization or notice, for a routine operation which does not require the approval of Form DM-4R,

2. The well shall be identified by a sign on the wellhead stating that the subsurface safety device has been removed. If the master valve is open, a trained person shall be in the immediate vicinity of the well to attend the well so that emergency actions may be taken, if necessary.

3. A platform well shall be monitored, but a person need not remain in the well-bay area continuously if the master valve is closed. If the well is on a satellite structure, it must be attended or a pump-through plug installed in the tubing at least 100 feet below the mud line and the master valve closed, unless otherwise approved by the district manager.

4. Each operator shall maintain records indicating the date a subsurface safety valve is removed, the reason for its removal, and the date it is reinstalled

D. Emergency Action. In the event of an emergency, such as an impending storm, any well not equipped with a subsurface safety device and which is capable of natural flow shall have the device properly installed as soon as possible with due consideration being given to personnel safety.

E. Design and Operation

1. All SSSVs must be inspected, installed, maintained, and tested in accordance with API RP 14H, Recommended Practice for Installation, Maintenance, and Repair of Surface Safety Valves and Underwater Safety Valves Offshore.

2. Testing requirements for subsurface safety devices are as follows:

a. all SSSV's shall be tested for operation and for leakage at least once each calendar month, but at no time shall more than 6 weeks elapse between tests. SSSV's must be tested in accordance with the test procedures specified in API RP 14H. If a SSSV does not operate properly or if any fluid flow is observed during the leakage test, the valve shall be repaired or replaced.

b. each subsurface-controlled SSSV installed in a well shall be removed, inspected, and repaired or adjusted, as necessary, and reinstalled or replaced at intervals not exceeding 6 months for those valves not installed in a landing nipple and 12 months for those valves installed in a landing nipple.

3. Records must be retained for a period of 2 years for each safety device installed.

AUTHORITY NOTE: Promulgated in accordance with Act 157 of the Legislature of 1940.

HISTORICAL NOTE: Promulgated by the Department of Conservation, Office of Conservation, LR 38:

§1105. Waivers

A. Onshore Wells. Where the use of storm chokes would unduly interfere with normal operation of a well, the district manager may, upon submission of pertinent data, in writing, waive the requirements of this order.

B. Offshore Wells

1. The district manager, upon submission of pertinent data, in writing explaining the efforts made to overcome the particular difficulties encountered, may waive the use of a subsurface safety valve under the following circumstances, and may, in his discretion, require in lieu thereof a surface safety valve:

a. where sand is produced to such an extent or in such a manner as to tend to plug the tubing or make inoperative the subsurface safety valve;

b. when the flowing pressure of the well is in excess of 100 psi but is inadequate to activate the subsurface safety valve;

c. where flow rate fluctuations or water production difficulties are so severe that the subsurface safety valve would prevent the well from producing at its allowable rate;

d. where mechanical well conditions do not permit the installation of a subsurface safety valve;

e. in such other cases as the district manager may deem necessary to grant an exception.

AUTHORITY NOTE: Promulgated in accordance with Act 157 of the Legislature of 1940.

HISTORICAL NOTE: Adopted by the Department of Conservation, March 1, 1961, amended March 15, 1961, amended and promulgated by Department of Natural Resources, Office of Conservation, LR 20:1128 (October 1994), LR 38:

James H. Welsh
Commissioner

1210#009

DECLARATION OF EMERGENCY

**Department of State
Elections Division**

Emergency Election Day Paper Ballot Procedures
(LAC 31:I.Chapter 11)

The Department of State, pursuant to the emergency provisions of the Administrative Procedure Act, R.S. 49:953(B), and under the authority of R.S. 18:1353 and R.S. 36:742, has adopted LAC 31:I.Chapter 11 on an emergency basis to establish guidelines for paper ballot procedures to be used on election day in the event that the secretary of state or his designee declares an emergency. Prior to the 2010 census, all precincts in Louisiana had a minimum of two voting machines in each precinct. If one voting machine became inoperable, voters were still capable of voting on the other voting machine in the precinct. As a result of reapportionment, Louisiana now has many split precincts where only one voting machine is available for drayage and placement in the polling place for election day. Louisiana continues to maintain a five percent backup for election day failures and has the authorization to provide for the use of paper ballots on an emergency basis pursuant to R.S. 18:1352. The Department of State has found an imminent need to address paper ballot procedures for the fall 2012 elections for all the precincts in the state that have only one voting machine in the event that the voting machine in the precinct becomes inoperable on election day. Without this Rule, voting may be interrupted for voters in Louisiana who vote at a one voting machine precinct. These rules shall become effective September 17, 2012, and shall remain in effect for the maximum period allowed under the Administrative Procedures Act or until final rules are promulgated in accordance with law, whichever occurs first.

Title 31

ELECTIONS

Part I. Election Process

Chapter 11. Emergency Election Day Paper Ballot Voting Procedures

§1101. Emergency Declaration

A. The Department of State is establishing emergency election day paper ballot voting procedures to be followed if a precinct does not have a voting machine that is operable and the precinct is not located in a consolidated precinct which has the ballot for which the voters are eligible to vote on a voting machine and the secretary of state or his designee declares an emergency.

AUTHORITY NOTE: Promulgated in accordance with R.S. 18:1352, R.S. 18:1353, and R.S. 36:742.

HISTORICAL NOTE: Promulgated by the Department of State, Elections Division, LR 38:

§1103. Preparation and Supplies for Implementation of Emergency Election Day Paper Ballot Voting Procedures

A. Emergency Declaration—Preparation Prior To Election Day

1. The secretary of state or his designee shall review all voting machine allocation reports and provide supplies

for implementation of the emergency election day paper ballot voting procedures for any precinct which has only one voting machine allocated for the election and is not located in a consolidated polling place which has the ballot for which the voters are eligible to vote on a voting machine. Supplies shall be provided in the back of the voting machine for immediate implementation upon a written declared emergency.

2. The clerk of court shall provide training to the commissioners for each one voting machine precinct on the implementation of the emergency election day paper ballot voting procedures as provided for herein.

3. The clerk of court shall inform the parish board of election supervisors or the absentee commissioners appointed to count the mail and early voting ballots of the possibility of having to implement the emergency election day paper ballot voting procedures due to the one machine precinct(s) in the parish.

B. Emergency Declaration—Supplies and Implementation Procedures

1. The commissioner-in-charge shall follow the directions in his parish for notifying the clerk of court and the Department of State when a precinct does not have a voting machine that is operable. The clerk of court, registrar of voters, and the secretary of state, or his designee, shall consult on the matter before an emergency is declared.

2. If the secretary of state, or his designee, declares an emergency, the secretary, or his designee, shall notify the clerk of court in writing, who shall notify the commissioners to implement the emergency election day paper ballot voting procedures provided for herein. The clerk of court shall also notify either the parish board of election supervisors or the appointed absentee commissioners of the declared emergency, so that they will be available to count the paper ballots on election night.

3. The secretary of state will provide all ballots and supplies to be used for the emergency election day paper ballot voting procedures. Supplies shall include: paper ballots identified by the corresponding button number of the machine lockout for the precinct and secrecy envelopes; a notice to the voters to be posted; instructions for the commissioners; a paper ballot audit form (in duplicate) to be used by the commissioners; a large return envelope labeled election day voted paper ballots; and any other supplies as determined necessary by the secretary or his designee.

4. The commissioner-in-charge shall post a notice at the entrance to the polling place notifying the voters that they will be allowed to vote on paper ballots. The commissioner-in-charge shall remove the notice when the precinct has a voting machine that is operable and voting resumes on the voting machine.

5. The commissioners shall use the instructions provided to follow the proper procedures in implementing the emergency election day paper ballot voting procedures.

6. The commissioner-in-charge shall complete the relevant parts of the paper ballot audit form prior to distribution of any paper ballot, such as the parish/ward/precinct information, time of implementation of procedures, lockout button number on ballot envelope, and total number of ballots per lockout button received in the lead machine. The commissioner-in-charge shall use this form to account for the number of voted paper ballots sealed

in secrecy envelopes per button number, the number of spoiled ballots sealed in secrecy envelopes per button number, and the number of unused ballots per button number. This information will provide an accurate accounting of the paper ballots supplied to the precinct per button number. At the end of the election day, the original paper ballot audit form shall be placed in the large return envelope labeled election day voted paper ballots for delivery to the clerk of court and a duplicate copy shall be posted at the precinct.

7. Paper ballots shall only be used during the time when the precinct does not have a voting machine that is operable and the secretary of state or his designee has declared an emergency in writing for implementation of the emergency election day paper ballot voting procedures.

AUTHORITY NOTE: Promulgated in accordance with R.S. 18:551, R.S. 18:1352, R.S. 18:1353, and R.S. 36:742.

HISTORICAL NOTE: Promulgated by the Department of State, Elections Division, LR 38:

§1105. Procedures for Voting and Termination of Voting for Paper Ballots

A. Allowing the Voters to Vote Paper Ballots

1. The commissioner shall continue to follow the normal procedures of verifying the voter and having the voter sign the precinct register as provided in the "Election Day Procedures" provided in Part 3 of the *Informational Pamphlet for Election Day Voting*.

2. Additionally, the commissioner shall initial the precinct register opposite the voter's signature or mark and write "Paper Ballot" in the "Lockout Districts" column on the line in the precinct register where the voter is listed.

3. After the commissioner initials the precinct register and writes "Paper Ballot" in the precinct register, the commissioner shall:

a. remove a ballot and secrecy envelope from the large ballot envelope labeled with the button number for the voter that is listed in the precinct register and account for the distribution of that specific ballot number on the paper ballot audit form. (Hash marks or similar counting marks may be used and then totaled at the end of voting to report a final total for each column on the paper ballot audit form.);

b. give the voter the ballot, the secrecy envelope and a pencil or pen;

c. instruct the voter to read and follow the instructions at the top of the ballot to mark the ballot according to those instructions and to seal the ballot in the secrecy envelope after he has completed voting;

d. the commissioner shall allow the voter to go to an area inside the polling place where he can mark his ballot in private and seal his voted ballot in the secrecy envelope; and

e. instruct the voter to return the sealed voted ballot in the secrecy envelope to the commissioner.

4. If the voter spoils his ballot and requests a new ballot, the commissioner shall:

a. instruct the voter to seal his spoiled ballot in the secrecy envelope before collecting the spoiled ballot;

b. write "Spoiled" across the ballot envelope and initial;

c. give the voter a new ballot; and

d. account for the distribution of the new ballot and the spoiled ballot on the paper ballot audit form and place

the spoiled ballot envelope in the large return envelope labeled election day voted paper ballots.

5. Upon receipt of the voted ballot in the secrecy envelope from the voter, the commissioner shall account for the voted ballot on the paper ballot audit form and place the secrecy envelope in the large return envelope labeled election day voted paper ballots. The secrecy envelopes with the voted paper ballots shall be retained in the election day voted paper ballots envelope.

B. Termination of Voting Paper Ballots

1. Paper ballots shall only be used during the time when the precinct does not have a voting machine that is operable and the secretary of state, or his designee, has declared an emergency in writing for implementation of the emergency election day paper ballot voting procedures.

2. The commissioner-in-charge shall notify the clerk of court when the voting of paper ballots is terminated due to an operable voting machine and shall indicate the time on the paper ballot audit form. The clerk of court shall then notify the secretary of state, or his designee.

C. Closing the Polling Place

1. After the closing of the polling place, the commissioners shall follow the instructions to complete the paper ballot audit form and certify to its accuracy and place the original paper ballot audit form, all sealed secrecy envelopes containing voted ballots, all spoiled ballot envelopes, and all unused paper ballots and secrecy envelopes in the large return envelope labeled election day voted paper ballots.

2. The commissioner-in-charge shall post a duplicate copy of the paper ballot audit form next to the posted voting machine results tape.

3. The commissioner-in-charge shall place the large return envelope labeled election day voted paper ballots in the clear plastic zipper bag along with the election results cartridges and deliver the bag to the clerk of court.

AUTHORITY NOTE: Promulgated in accordance with R.S. 18:49.1, R.S. 18:564, R.S. 18:565, R.S. 18:1352, R.S. 18:1353, and R.S. 36:742.

HISTORICAL NOTE: Promulgated by the Department of State, Elections Division, LR 38:

§1107. Delivery of “Election Day Voted Paper Ballots” Envelope and Tabulation and Counting of Paper Ballots

A. Election Day Voted Paper Ballots Envelope

1. Upon receipt of the “election day voted paper ballots” envelope on election night, the clerk of court or his designee shall deliver the envelope to the parish board of election supervisors or absentee commissioners for tabulation of the election day voted paper ballots.

B. Counting and Tabulating the Votes

1. The paper ballots cast at the polling place shall be counted by the parish board of election supervisors or the absentee commissioners on election night according to the procedures for counting absentee by mail ballots in R.S. 18:1313, R.S. 18:1315, R.S. 18:1316, and the specific procedures provided for herein.

2. A member of the parish board or an absentee commissioner shall remove the paper ballots audit form, the sealed secrecy envelopes containing the voted ballots, the

spoiled ballot envelopes, and the unused paper ballots from the election day voted paper ballots envelope and check to confirm that the paper ballots audit form is correct and matches what is delivered in the election day voted paper ballots envelope. If there are any discrepancies, the board or absentee commissioners shall make a notation of the discrepancy on the original paper ballots audit form and certify by their signature to the accuracy of their notation.

3. Each voted ballot shall be removed from the secrecy envelope and a member of the parish board or an absentee commissioner shall write “ED” for election day and his initials in the space on the ballot directly below the secretary of state’s signature so as not to mark on the dark black timing marks on the sides of the ballots and to distinguish the election day paper ballots from the absentee by mail paper ballots.

4. The election day paper ballots shall be segregated from the absentee by mail paper ballots and shall be kept segregated by precinct to be counted and reported by precinct.

5. The parish board of election supervisors or the absentee commissioners may elect to count the election day paper ballots manually or they may use the scanning equipment. The election day paper ballots shall be counted separately from the absentee by mail paper ballots and shall be counted and reported by precinct. The secretary of state shall provide written instructions to assist with the counting of paper ballots by precinct.

6. Upon completion of the counting of the election day paper ballots, a member of the parish board of election supervisors or absentee commissioner shall enter the vote totals from the election day paper ballots for each precinct on a worksheet which shall be signed by the board or absentee commissioners and delivered to the clerk of court for entering of the results.

7. The clerk of court or his designee on election night shall add the vote totals for the election day paper ballots from the worksheet to the vote totals for each precinct in the Department of State’s Elections and Registration Information Network (ERIN). The secretary of state shall provide written instructions to assist with the entering of these vote totals.

8. Upon completion of the counting of the election day paper ballots, the voted ballots and secrecy envelopes, the original paper ballots audit form, the spoiled ballot envelopes, and all unused ballots and secrecy envelopes shall be returned to the election day voted ballots envelope and the envelope shall be retained by the registrar of voters in accordance with the procedures for retention of absentee by mail ballots in R.S. 18:1312.

AUTHORITY NOTE: Promulgated in accordance with R.S. 18:1312, R.S. 18:1313, R.S. 18:1315, R.S. 18:1316, R.S. 18:1352, R.S. 18:1353, and R.S. 36:742.

HISTORICAL NOTE: Promulgated by the Department of State, Elections Division, LR 38:

Tom Schedler
Secretary of State

1210#004

DECLARATION OF EMERGENCY

**Department of Transportation and Development
Office of Operations**

Special Permit for Vehicles Hauling Sugarcane
(LAC 73:I.303)

In accordance with the emergency provisions of the Administrative Procedure Act, R.S. 49:953(B), and under the authority of R.S. 32:387.7, the secretary for the Department of Transportation and Development declares that an emergency exists and adopts by emergency process the attached regulation. Effective August 1, 2012, Act 462 of the 2012 of the Regular Session of the Louisiana State Legislature amended R.S. 32:387.7(B) to prohibit the secretary for the Department of Transportation and Development from issuing permits for vehicles hauling sugarcane with a vehicle combination at a gross weight of one hundred thousand pounds without an additional single axle on the sugarcane trailer for a total of six axles for the vehicle and trailer combination.

The amendment did not specify whether or not the additional sixth axel had to be equipped with single or dual mounted tires. The department has determined that dual mounted tires on the additional axle are necessary for the safe operation of the vehicles on the Interstate, state and local roadways. Dual mounting distributes the weight of the load in a manner calculated to prevent excessive damage to roadways and bridges.

This Emergency Rule shall become effective upon signature of the secretary, September 27, 2012. This Emergency Rule shall be in effect for the maximum period allowed under the Administrative Procedure Act or until adoption of the final Rule, whichever occurs first.

Title 73

WEIGHTS, MEASURES AND STANDARDS

Part I. Weights and Standards

Chapter 3. Oversize and Overweight Permit

§303 Types of Permits

A. - J. ...

K. Vehicles Hauling Sugarcane. These permits are issued annually for vehicles hauling sugarcane at a gross weight not to exceed one hundred thousand pounds. The vehicle and trailer combination must meet all of the requirements contained Louisiana Regulations for Trucks, Vehicles and Loads 2012, and shall have an additional single axle on the sugarcane trailer for a total of six axles for the vehicle and trailer combination. The additional axle must be equipped with dual mounted tires lowered to the ground and functioning as a load bearing axle when hauling sugarcane. The fee for these permits is \$100 per permit per year.

AUTHORITY NOTE: Promulgated in accordance with 32:2 et seq.

HISTORICAL NOTE: Promulgated by the Department of Transportation and Development, Office of Highways, LR 5:36 (February 1979), amended by the Department of Transportation and Development, Office of Operations LR 38:

Eric Kalivoda
Deputy Secretary

1210#011

DECLARATION OF EMERGENCY

**Department of Wildlife and Fisheries
Wildlife and Fisheries Commission**

2012-13 Deer Season Rules and Regulations—Adjustment

In accordance with the emergency provisions of R.S. 49:953, R.S.56:115, and R.S.56:116 of the Administrative Procedure Act, and under the authority of R.S. 56:6.1, the Wildlife and Fisheries Commission hereby alters the previously established deer hunting seasons for 2012-13 for the specific areas described below.

Lake Maurepas Basin Defined Area: Portions of St. Tammany, Tangipahoa, Livingston, Ascension, St. James, St. John and St. Charles parishes; beginning west of the Tchefuncte River from Lake Pontchartrain to LA 22; also south and east of LA 22 to LA 70, and east of LA 70 to LA 3125; and north and east of LA 3125 to LA 641; and west of LA 641 to US 61; then north of US 61 to the Jefferson Parish line.

Archery Season—no change

Youth, Bucks only, still: Oct. 27-28 (2 days)

Bucks only, still: Nov. 23 - Dec. 2 (10 days)

Bucks only, with or without dogs: Dec. 8 - 30 (23 days)

Bucks only, primitive: Jan. 19 - 27 (9 days)

Plaquemines Parish and St. Bernard Parish, outside of the major flood wall:

Archery Season—no change

Youth, Bucks only, still: Oct. 27-28 (2 days)

Bucks only, still: Nov. 23-25 (3 days)

Bucks only, with or without dogs: Dec. 22-Jan.6 (16 days)

Bucks only, primitive: Jan. 19 - 27 (9 days)

Wildlife Management Areas:

Biloxi WMA—Archery Season—no change

Joyce WMA—same as *Lake Maurepas Basin Defined Area*, except still hunt only

Manchac WMA - Archery Season - no change

Maurepas Swamp WMA

Archery Season—no change

Youth, Bucks only: Nov. 3-4 (2 days)

Bucks only, modern firearms, mandatory check: Nov. 23 (1 day)

Bucks only, modern firearms: Nov. 24 - 25 (2 days)

Bucks only, modern firearms: Dec. 22 - 28 (7 days)

Bucks only, primitive: Jan. 14 - 20 (7 days)

Pass-a-Loutre WMA—

Archery Season—no change

Bucks only shotgun—no change

These actions are being taken as a result of significant deer mortality estimated within the flood zone areas identified above as a result of Hurricane Isaac. The aforementioned 2012-2013 deer hunting seasons will become effective October 4, 2012.

Ann L. Taylor
Chairman

1210#104

DECLARATION OF EMERGENCY

Department of Wildlife and Fisheries Wildlife and Fisheries Commission

East Zone Alligator Season Extension

In accordance with the provisions of R.S. 49:953B of the Administrative Procedure Act and LAC 76:V.701.A.7.a.i., the Secretary of the Department of Wildlife and Fisheries does hereby extend the closing date of the 2012 wild alligator harvest season in the East Zone as set out below.

Hurricanes Isaac struck Louisiana resulting in significant damage in southeastern Louisiana. This catastrophe has severely impacted residents, flooded many homes, and thousands of acres of coastal marshes. Alligator populations in affected areas have been displaced and suffered some degree of direct mortality. Assessment of these impacts is ongoing. Additionally, many alligator hunters in the affected areas were displaced and have had their harvest efforts

delayed due to storm impacts. Income for the annual wild alligator harvest often provides significant economic relief to these coastal residents. Therefore, the closing date of the 2012 East Zone wild alligator season will be extended seven days to close on Thursday October 4, 2012. This closing date coincides with the closing date for the West Zone wild alligator season. Alligators taken from the wild may be removed from hook and line, and other legal capture devices only during daylight hours between official sunrise and official sunset. Hunters are reminded to coordinate their harvest activity with their local alligator buyer or processor as they may have also been affected by the hurricane.

This Declaration of Emergency shall expire on October 4, 2012.

Robert J. Barham
Secretary

1210#005

Rules

RULE

Department of Agriculture and Forestry Feed, Fertilizer and Agricultural Liming Commission

Feed, Fertilizer, and Agricultural Liming
(LAC 7:XI.Chapter 1, XVII.Chapter 1, and XIX.101)

In accordance with the Administrative Procedure Act, R.S. 49:950 et seq., and with the enabling statute, R.S. 3:1382, the Department of Agriculture and Forestry amends its Rules and regulations to remove duplicative language, to provide technical changes, to provide proper citations and to revise the regulations to be consistent with the terminology in the Feed, Fertilizer and Agricultural Liming Law. Act 579 of the 2010 Regular Session merged the Fertilizer Commission and the Feed Commission creating the Feed, Fertilizer and Agricultural Liming Commission. The changes ensure the Rules are consistent with the statute. The changes relative to liming specify the method of analysis and tolerance used in the analysis of agricultural liming materials.

Title 7

AGRICULTURE AND ANIMALS

Part XI. Fertilizers

Chapter 1. Sale of Fertilizers

§101. Definitions

* * *

Adulteration—any situation:

1. - 4. ...

Analysis—Repealed.

* * *

Commission—the Feed, Fertilizer, and Agricultural Liming Commission.

* * *

Guarantor and/or *Registrant*—repealed.

Guarantor—a person who manufactures, sells or offers fertilizer for sale under his name or brand.

* * *

Registrant—a person who has been registered by the commission as required by R.S. 3:1413(A).

* * *

State Chemist—the director of the Louisiana Agricultural Experiment Station of the Louisiana State University Agricultural Center, or his designee.

* * *

AUTHORITY NOTE: Promulgated in accordance with R.S. 3:1392.

HISTORICAL NOTE: Promulgated by the Department of Agriculture, Fertilizer Commission, LR 7:164 (April 1981), amended LR 12:493 (August 1986), amended by the Department of Agriculture and Forestry, Feed, Fertilizer, and Agricultural Liming Commission, LR 38:2521 (October 2012).

§103. Registration Requirements

A. Every guarantor who manufactures, sells, or offers fertilizer for sale under his brand or company name within the state of Louisiana shall be registered with the commission. Fertilizer processed or manufactured in

Louisiana and offered for sale or distributed solely outside the state of Louisiana is not required to be registered.

B. Applicants for registration may request application forms, verbally or in writing, from the commission.

C. Each registration shall be valid until December 31 of each year. To remain valid, each registration shall be renewed on or before January 1 of each year.

D. Applications for annual renewal of registration shall be mailed by the commission to all registrants, at the last address provided by the registrant, on or before November 15 of each year and shall be returned on or before January 1 of each year.

E. The record of all registrations shall be maintained by the commission and the director of Agricultural Chemistry Programs in the Agricultural Chemistry Building, Louisiana State University in Baton Rouge.

AUTHORITY NOTE: Promulgated in accordance with R.S. 3:1392.

HISTORICAL NOTE: Promulgated by the Department of Agriculture, Fertilizer Commission, LR 7:164 (April 1981), amended LR 12:494 (August 1986), amended by the Department of Agriculture and Forestry, Feed, Fertilizer, and Agricultural Liming Commission, LR 38:2521 (October 2012).

§105. Labeling Requirements

A. When minor elements, pesticides, and/or seeds are added, the label, tag, or printed invoice shall contain the following:

1. guarantee of the fertilizer (percent by weight) before the addition of minor elements, pesticides and/or seeds;

2. amount per ton of minor elements, pesticides and/or seeds added; and

3. percent by weight of the active ingredients added.

B. All additives shall be clearly labeled as such.

C. The validity of claims on the label, tag or printed invoice will be verified by the director of Agricultural Chemistry Programs. No false or misleading statements indicating that additives possess fertilizer properties will be permitted.

D. When two or more fertilizer materials are mixed or blended together, the guarantor shall indicate on the label, tag, or printed invoice, the percent by weight of nitrogen (N), available phosphoric acid (P₂O₅), and soluble potash (K₂O) in the final mixture.

AUTHORITY NOTE: Promulgated in accordance with R.S. 3:1392.

HISTORICAL NOTE: Promulgated by the Department of Agriculture, Fertilizer Commission, LR 7:164 (April 1981), amended LR 12:494 (August 1986), amended by the Feed, Fertilizer, and Agricultural Liming Commission, LR 38:2521 (October 2012).

§107. Required Guarantees

A. Guarantees of the plant nutrients shall be expressed as percent by weight.

B. ...

C. Every mixed fertilizer shall contain a minimum of 20 percent by weight of the primary nutrients, nitrogen (N), available phosphoric acid (P₂O₅), and soluble potash (K₂O),

except those products whose primary purpose is to supply minor nutrients.

D. All plant nutrients other than nitrogen (N), available phosphoric acid (P₂O₅), and soluble potash (K₂O), if listed on the label or invoice, shall be guaranteed on an elemental basis.

E. - F. ...

AUTHORITY NOTE: Promulgated in accordance with R.S. 3:1392.

HISTORICAL NOTE: Promulgated by the Department of Agriculture, Fertilizer Commission, LR 7:164 (April 1981), amended LR 12:494 (August 1986), amended by the Department of Agriculture and Forestry, Feed, Fertilizer, and Agricultural Liming Commission, LR 38:2521 (October 2012).

§113. Chemical Analysis of Fertilizer

A. - D. ...

E. Results of the fertilizer analysis shall be mailed to the guarantor within 30 days after the sample is taken. If the test results are not mailed to the guarantor within 30 days after the sample was taken, the guarantor may request in writing, within 10 days of receipt of notice of deficiency, a hearing before the commission for a determination of the validity of any penalties assessed.

F. ...

AUTHORITY NOTE: Promulgated in accordance with R.S. 3:1392.

HISTORICAL NOTE: Promulgated by the Department of Agriculture, Fertilizer Commission, LR 7:164 (April 1981), amended LR 12:495 (August 1986), amended by the Department of Agriculture and Forestry, Feed, Fertilizer, and Agricultural Liming Commission, LR 38:2522 (October 2012).

§115. Tonnage Reports; Inspection Fees

Repealed.

AUTHORITY NOTE: Promulgated in accordance with R.S. 3:1392.

HISTORICAL NOTE: Promulgated by the Department of Agriculture, Fertilizer Commission, LR 7:164 (April 1981), amended LR 12:495 (August 1986), amended by the Department of Agriculture and Forestry, Office of the Commissioner, Fertilizer Commission, LR 30:195 (February 2004), repealed by the Department of Agriculture and Forestry, Feed, Fertilizer, and Agricultural Liming Commission, LR 38:2522 (October 2012).

§117. Penalties; Deficiencies; Curing of Deficiencies

A. The commission shall levy penalties as set forth in R.S. 3:1419, against the guarantor of any lot or package of fertilizer found by chemical analysis to be deficient in the primary plant nutrients, as follows.

Element	% by Weight Guaranteed	Deficiency	Penalty
Nitrogen	0.0%-8.0%	0.4%	4 x Value of Deficiency
	8.1%-20.9%	0.5%	Same
	21.0% and above	0.8%	Same
Phosphorus	0.0%-10.0%	0.4%	Same
	10.1%-25.9%	0.5%	Same
	26.0% and above	0.8%	Same
Potassium	0.0%-8.0%	0.5%	Same
	8.1%-20.9%	0.6%	Same
	21.0% and above	1.0%	Same

C. B. The value of the deficiency shall be calculated as follows:

$$\frac{(\text{Guaranteed Analysis} - \text{Actual Analysis}) \times \text{Value of Element/Unit} \times \text{Tons in Shipment} \times 4}{100}$$

AUTHORITY NOTE: Promulgated in accordance with R.S. 3:1392.

HISTORICAL NOTE: Promulgated by the Department of Agriculture, Fertilizer Commission, LR 7:164 (April 1981), amended LR 12:496 (August 1986), amended by the Department of Agriculture and Forestry, Feed, Fertilizer, and Agricultural Liming Commission, LR 38:2522 (October 2012).

§119. Prohibitions against Penalties

Repealed.

AUTHORITY NOTE: Promulgated in accordance with R.S. 3:1392.

HISTORICAL NOTE: Promulgated by the Department of Agriculture, Fertilizer Commission, LR 7:164 (April 1981), amended LR 12:496 (August 1986), repealed by the Feed, Fertilizer, and Agricultural Liming Commission, LR 38:2522 (October 2012).

§121. Payment of Penalties

A. When the penalty is paid by the guarantor to the purchaser, the guarantor shall provide proof of such payment to the commission within 30 days of the date on which the notice of the penalty is mailed to the guarantor. A copy of the check payable to the purchaser shall constitute proof.

B. The face and/or the stub of all checks for penalty payments shall contain the laboratory number which appears on the report of the analysis.

C. Penalties paid to the commission shall be deposited into the Feed and Fertilizer Fund as provided for in R.S. 3:1421.

AUTHORITY NOTE: Promulgated in accordance with R.S. 3:1392.

HISTORICAL NOTE: Promulgated by the Department of Agriculture, Fertilizer Commission, LR 7:164 (April 1981), amended LR 12:496 (August 1986), amended by the Department of Agriculture and Forestry, Feed, Fertilizer, and Agricultural Liming Commission, LR 38:2522 (October 2012).

§123. Recall of Deficient Fertilizer; Cancellation of Penalties upon Proof of Recall

A. ...

1. Prior to action to retrieve the deficient product, the guarantor shall notify the director of Agricultural Chemistry Programs and secure his approval for the recall.

2. Prior to action to retrieve the deficient product, the purchaser shall agree to the recall.

3. An agricultural inspector shall be present when the product is picked up from the purchaser.

4. The guarantor shall reimburse the purchaser the full purchase price of the product.

5. The guarantor shall furnish the director of Agricultural Chemistry Programs with a copy of the refund check and/or credit memo covering the full purchase price of the product. The purchaser and inspector shall certify in writing to the commissioner that the deficient fertilizer was returned to the guarantor and that a refund check or credit memo was issued.

B. When some, but not all, of a product which is found to be deficient is recalled as provided in §123.A, the guarantor shall pay the required penalty on any portion which cannot be recalled. In this circumstance, the penalty shall be paid to the purchaser, if known, subject to the requirements of §121, or to the commission, within 30 days of the date of the notice of the penalty.

C. ...

AUTHORITY NOTE: Promulgated in accordance with R.S. 3:1392.

HISTORICAL NOTE: Promulgated by the Department of Agriculture, Fertilizer Commission, LR 7:164 (April 1981), amended LR 12:496 (August 1986), amended by the Department of Agriculture and Forestry, Feed, Fertilizer, and Agricultural Liming Commission, LR 38:2522 (October 2012).

§127. Probationary Status of Registrants

A. A registrant shall be placed on probation by the commission when 25 percent of the official samples taken from a single registrant during one year are found to be deficient; provided that a minimum of four samples and at least 2 percent of the total tonnage sold during that year is sampled.

B. A registrant located within the state of Louisiana who is placed on probation shall be subject to an increase of sampling up to 20 percent of the total product offered for sale until the probation is terminated by the commission.

C. ...

D. Notification shall be given, in writing, to any registrant placed on probation within 30 days of the date on which the commission took action to place the registrant on probationary status. Notification shall not be required for any registrant already on probation at the effective date of these regulations.

E. ...

F. If a registrant continues to introduce products of which the official samples' deficiency exceeds 25 percent into the stream of commerce for one year, the registrant shall be summoned before the commission at its next meeting after the end of the year of probationary status, to determine whether registration shall be canceled or renewal of registration shall be denied for cause.

G. ...

AUTHORITY NOTE: Promulgated in accordance with R.S. 3:1392.

HISTORICAL NOTE: Promulgated by the Department of Agriculture, Fertilizer Commission, LR 7:164 (April 1981), amended LR 12:496 (August 1986), amended by the Department of Agriculture and Forestry, Feed, Fertilizer, and Agricultural Liming Commission, LR 38:2523 (October 2012).

§131. Appeals from Action of the Commission/Department of Agriculture and Forestry

A. - A.2. ...

3. If the difference concerning the manner of taking the sample cannot thus be resolved, the guarantor may place his complaint on the agenda at the next meeting of the commission. Routine procedures for submission and analysis of the sample shall be followed pending the resolution of the differences at such hearing.

B. Appeals Concerning Results of Chemical Analysis

1. When a guarantor, or his agent, disagrees with a finding of deficiency or a calculation of a penalty resulting from a finding of deficiency, he shall register his complaint, in writing, with the director of Agricultural Chemistry Programs within 10 days of the date of the report of chemical analysis.

2. When questions concerning the accuracy of the analysis made by the director of Agricultural Chemistry Program cannot be amicably resolved, the guarantor may place his complaint on the agenda at the next meeting of the commission for a final determination.

3. When a disagreement on a fertilizer deficiency arises, the sample may be analyzed by an independent laboratory agreeable to the commissioner.

C. Appeals Concerning Probationary Status

1. Any guarantor who is placed on probationary status may appeal his probation at any time by submitting to the commission a written statement on the basis of his appeal and a written request for a hearing on the matter. A request for a hearing on appeal from probationary status shall not be delayed but shall be placed on the agenda for the next meeting of the commission following receipt of the request for a hearing.

D. - D.1. ...

2. When the commission determines that just cause may exist to cancel or deny renewal of registration, the commission shall give written notice to the registrant of intent to conduct adjudicatory hearing on the matter. The notice shall be given at least 15 days prior to the date on which the hearing shall be held and shall contain all of the facts required under R.S. 49:950 et seq. The notice shall be sent by certified mail, return receipt requested, to the registrant at the last address provided by the registrant.

3. ...

4. If a controversy still exists at the conclusion of any such adjudicatory hearing called for cancellation of registration and/or denial of renewal of registration, the guarantor may appeal the matter in accordance with the Administrative Procedure Act, provided that all such matters shall be lodged in the parish in which the commission is domiciled.

AUTHORITY NOTE: Promulgated in accordance with R.S. 3:1392.

HISTORICAL NOTE: Promulgated by the Department of Agriculture, Fertilizer Commission, LR 7:164 (April 1981), amended LR 12:497 (August 1986), amended by the Department of Agriculture and Forestry, Feed, Fertilizer, and Agricultural Liming Commission, LR 38:2523 (October 2012).

§133. Confidentiality of Records

A. Information concerning the amount of fertilizer sold and the business practices of registrants which is obtained from tonnage reports shall be kept confidential and shall not be revealed to the public or to other registrants by the commission, the commissioner, nor any employee of the Department of Agriculture and Forestry.

AUTHORITY NOTE: Promulgated in accordance with R.S. 3:1392.

HISTORICAL NOTE: Promulgated by the Department of Agriculture, Fertilizer Commission, LR 7:164 (April 1981), amended LR 12:497 (August 1986), amended by the Department of Agriculture and Forestry, Feed, Fertilizer, and Agricultural Liming Commission, LR 38:2523 (October 2012).

§135. Penalties for Violations

Repealed.

AUTHORITY NOTE: Promulgated in accordance with R.S. 3:1392.

HISTORICAL NOTE: Promulgated by the Department of Agriculture, Fertilizer Commission, LR 7:164 (April 1981), amended LR 12:497 (August 1986), repealed by the Department of Agriculture and Forestry, Feed, Fertilizer, and Agricultural Liming Commission, LR 38:2523 (October 2012).

137. Repeal of Prior Rules and Regulations

Repealed.

AUTHORITY NOTE: Promulgated in accordance with R.S. 3:1392.

HISTORICAL NOTE: Promulgated by the Department of Agriculture and Forestry, Fertilizer Commission, LR 7:164 (April 1981), amended LR 12:498 (August 1986), repealed by the Department of Agriculture and Forestry, Feed, Fertilizer, and Agricultural Liming Commission, LR 38:2524 (October 2012).

Part XVII. Feed

Chapter 1. Commercial Feeds

Subchapter A. Official Feed

§101. Definitions and Terms

A. - B. ...

C. The following commodities are hereby declared exempt from the definition of commercial feed, under the provisions of R.S. 3:1391(3): raw meat, and hay, straw, stover, silages, cobs, husks and hulls when unground and when not mixed or intermixed with other materials; provided that these commodities are not adulterated within the meaning of R.S. 3:1396.

D. Individual chemical compounds and substances are hereby declared exempt from the definition of commercial feed under the provisions of R.S. 3:1391(3). It has been determined that these products meet the following criteria.

D.1. - E.

F. Definitions

Commission—the Louisiana Feed, Fertilizer, and Agricultural Liming Commission.

Commissioner—the commissioner of agriculture and forestry or his duly authorized representatives acting at his direction.

Crude Fat—the percent ether extract (or other appropriate fat solvent extract) determined by the appropriate official method outlined in AOAC official methods of analysis.

Crude Fiber—the portion of a feed or ration which is determined by using the appropriate official method as outlined in the AOAC Official Methods of Analysis.

Crude Protein—the percent nitrogen times 6.25 where the percent nitrogen is determined by the appropriate official method outlined in AOAC Official Methods of Analysis.

Invert Sugar—a mixture of glucose and fructose resulting from the hydrolysis of sucrose. The value of invert sugars are determined by official methods outlined in AOAC Official Methods of Analysis. The method varies with the type of material being analyzed.

Livestock—cattle, buffalo, bison, oxen, and other bovine; horses, mules, donkeys, and other equine; sheep; goats; swine; domestic rabbits; fish, turtles, and other animals identified with aquaculture that are located in artificial reservoirs or enclosures that are both on privately owned property and constructed so as to prevent, at all times, the ingress and egress of fish life from public waters; imported exotic deer and antelope, elk, farm-raised white-tailed deer, farm-raised ratites, and other farm-raised exotic animals; chickens, turkeys, and other poultry; and animals placed under the jurisdiction of the commissioner of agriculture and forestry and any hybrid, mixture, or mutation of any such animal.

Official Sample—a sample of feed taken by the commissioner or his agent in accordance with provisions of R.S. 3:1398.

Rule, Rules, Regulation, Regulations or Rules and Regulations—those of the commission adopted initially and from time to time to achieve the intent and purposes of R.S. 3:1391, et seq. or to facilitate its administration.

State Chemist—the director of the Louisiana Agricultural Experiment Station of the Louisiana State University Agricultural Center, or his designee.

AUTHORITY NOTE: Promulgated in accordance with R.S. 3:1391 and R.S. 3:1392.

HISTORICAL NOTE: Promulgated by the Department of Agriculture, Feed Commission, LR 11:219 (March 1985), amended by the Department of Agriculture and Forestry, Feed, Fertilizer, and Agricultural Liming Commission, LR 38:2524 (October 2012).

§103. Label Format

A. - A.3.d. ...

4. the guaranteed analysis of the feed as required under the provisions of R.S. 3:1394(A)(3) include the following items, unless exempted in §103.A.4.h, and in the order listed:

a. - h.iii. ...

5. feed ingredients, collective terms for the grouping of feed ingredients, as provided under the provisions of R.S. 3:1394(A)(6):

5.a - 6. ...

7. the information required in R.S. 3:1394(A)(1) through R.S. 3:1394 (A)(7) must appear in its entirety on one side of the label or on one side of the container. The information required by R.S. 3:1394 (A)(8) and R.S. 3:1394 (A)(9) shall be displayed in a prominent place on the label or container but not necessarily on the same side as the above information. When the information required by R.S. 3:1394 (A)(8) and R.S. 3: 1394 (A)(9) is placed on a different side of the label or container, it must be referenced on the front side with a statement such as See back of label for directions for use. None of the information required by R.S. 3:1394 shall be subordinated or obscured by other statements or designs.

8. If the feed contains protein derived from mammalian tissues, a statement that the feed shall not be fed to ruminants.

B. - B.7.b. ...

8. If the feed contains protein derived from mammalian tissues, a statement that the feed shall not be fed to ruminants.

AUTHORITY NOTE: Promulgated in accordance with R.S. 3:1394, R.S. 3:1393 and R.S. 3:1392.

HISTORICAL NOTE: Promulgated by the Department of Agriculture, Feed Commission, LR 11:220 (March 1985), amended LR 11:943 (October 1985), amended by the Department of Agriculture and Forestry, Feed, Fertilizer, and Agricultural Liming Commission, LR 38:2524 (October 2012).

§115. Drug and Feed Additives

A. - B.1. ...

2. when the commercial feed is itself a drug as defined in R.S. 3:1391(3) and is generally recognized as safe and effective for the labeled use or is marketed subject to an

application approved by the Food and Drug Administration under Title 21 U.S.C. 360(b).

AUTHORITY NOTE: Promulgated in accordance with R.S. 3:1394 and R.S. 3:1392.

HISTORICAL NOTE: Promulgated by the Department of Agriculture, Feed Commission, LR 11:223 (March 1985), amended by the Department of Agriculture and Forestry, Feed, Fertilizer, and Agricultural Liming Commission, LR 38:2524 (October 2012).

§117. Adulterants

A. For the purpose of R.S. 3:1396(1), the terms poisonous or deleterious substances include but are not limited to the following:

A.1. - B. ...

AUTHORITY NOTE: Promulgated in accordance with R.S. 3:1392 and R.S. 3:1396.

HISTORICAL NOTE: Promulgated by the Department of Agriculture, Feed Commission, LR 11:223 (March 1985), amended by the Department of Agriculture and Forestry, Feed, Fertilizer, and Agricultural Liming Commission, LR 38:2525 (October 2012).

§119. Good Manufacturing Practices

A. For the purposes of enforcement of R.S. 3:1396 (8), the commission adopts the following as current good manufacturing practices:

1. - 2. ...

AUTHORITY NOTE: Promulgated in accordance with R.S. 3:1392 and R.S. 3:1396.

HISTORICAL NOTE: Promulgated by the Department of Agriculture, Feed Commission, LR 11:223 (March 1985), amended by the Department of Agriculture and Forestry, Feed, Fertilizer, and Agricultural Liming Commission, LR 38:2525 (October 2012).

§123. Protein Value

A. For the purpose of assessing penalties for protein deficiencies in feeds, as provided for in R.S. 3:1400(A)(1), the value of crude protein will be updated each quarter.

B. - B.1. ...

C. Penalties shall be assessed as provided for in R.S. 3:1400. If an official sample shows that feed ingredients bought by a feed manufacturer is deficient, any penalties from this deficiency shall be paid by the supplier of the ingredients to the manufacturer that bought the ingredients.

AUTHORITY NOTE: Promulgated in accordance with R.S. 3:1391 and R.S. 3:1392.

HISTORICAL NOTE: Promulgated by the Department of Agriculture, Feed Commission, LR 11:224 (March 1985), amended LR 11:944 (October 1985), amended by the Feed, Fertilizer, and Agricultural Liming Commission, LR 38:2525 (October 2012).

Subchapter B. Official Pet Food

§131. Expression of Guarantees

A. ...

B. Pursuant to R.S. 3:1394(A)(3), the label of a pet food which is formulated as and represented to be a mineral additive supplement, shall include in the guaranteed analysis the maximum and minimum percentages of calcium, the minimum percentage of phosphorus and the maximum and minimum percentages of salt. The minimum content of all other essential nutrient elements recognized by NRC from sources declared in the ingredient statement shall be expressed as the element and in units of measurement established by a recognized authority of animal nutrition, such as the National Research Council.

C. Pursuant to R.S. 3:1394 (A)(3), the label of pet food which is formulated as and represented to be a vitamin supplement, shall include a guarantee of the minimum content of each vitamin declared in the ingredient statement. Such guarantees shall be stated in units of measurements

established by a recognized authority on animal nutrition such as the National Research Council.

D. - E. ...

AUTHORITY NOTE: Promulgated in accordance with R.S. 3:1392, R.S. 3:1393 and R.S. 3:1394.

HISTORICAL NOTE: Promulgated by the Department of Agriculture, Feed Commission, LR 11:226 (March 1985), amended by the Department of Agriculture and Forestry, Feed, Fertilizer, and Agricultural Liming Commission, LR 38:2525 (October 2012).

§135. Drugs and Pet Food Additives

A. - B.1. ...

2. when the pet food itself is a drug as defined in R.S. 3:1391(3) and is generally recognized as safe and effective for label use or is marketed subject to an application approved by the Food and Drug Administration under Title 21, U.S.C. 360(b).

C. ...

AUTHORITY NOTE: Promulgated in accordance with R.S. 3:1392 and R.S. 3:1394.

HISTORICAL NOTE: Promulgated by the Department of Agriculture, Feed Commission, LR 11:226 (March 1985), amended by the Department of Agriculture and Forestry, Feed, Fertilizer, and Agricultural Liming Commission, LR 38:2525 (October 2012).

§137. Fees

A. Fees for pet foods shall be the same as for other animal feeds as set forth in R.S. 3:1401 and §121 of the official feed rules and regulations.

AUTHORITY NOTE: Promulgated in accordance with R.S. 3:1392 and R.S. 3:1401.

HISTORICAL NOTE: Promulgated by the Department of Agriculture, Feed Commission, LR 11:226 (March 1985), amended by the Department of Agriculture and Forestry, Feed, Fertilizer, and Agricultural Liming Commission, LR 38:2525 (October 2012).

§139. Penalties

A. Penalties for pet food will be the same as penalties for other animal feeds as set forth in R.S. 3:1400 and §123 of the official feed rules and regulations.

AUTHORITY NOTE: Promulgated in accordance with R.S. 3:1392 and R.S. 3:1400.

HISTORICAL NOTE: Promulgated by the Department of Agriculture, Feed Commission, LR 11:226 (March 1985), amended by the Department of Agriculture and Forestry, Feed, Fertilizer, and Agricultural Liming Commission, LR 38:2525 (October 2012).

Subchapter C. Processed Animal Waste Products as Animal Feed Ingredients

§141. Definitions and Quality Standards

A. The commission adopts the definitions of R.S. 3:1381 and 1391 and those that appear in §101.F of the official feed rules and regulations.

B. ...

AUTHORITY NOTE: Promulgated in accordance with R.S. 3:1392.

HISTORICAL NOTE: Promulgated by the Department of Agriculture, Feed Commission, LR 11:226 (March 1985), amended by the Department of Agriculture and Forestry, Feed, Fertilizer, and Agricultural Liming Commission, LR 38:2525 (October 2012).

§143. Registration Required

A. No person shall sell, offer or expose for sale or distribute, in this state, any processed animal waste product intended, promoted, represented, advertised or distributed for use as a commercial feed unless he has registered with the commissioner, as specified in R.S. 3:1393.

B. Application for registration shall be made to the commission on forms provided by the commissioner and shall be accompanied by payment of the registration fees as

set forth in §121 of the official feed rules and regulations adopted by the commission.

C. - C.2. ...

3. a sampling schedule, a full description of all tests made and the results, thereby purporting to show the processed animal waste product meets the standards of the Louisiana Department of Agriculture and Forestry and the Office of the Louisiana State Livestock Sanitary Board and these rules and regulations for registration.

AUTHORITY NOTE: Promulgated in accordance with R.S. 3:1392 and R.S. 3:1393.

HISTORICAL NOTE: Promulgated by the Department of Agriculture, Feed Commission, LR 11:226 (March 1985), amended by the Department of Agriculture and Forestry, Feed, Fertilizer, and Agricultural Liming Commission, LR 38:2525 (October 2012).

§145. Registration Refused or Canceled

A. - A.2. ...

3. the processed animal waste product does not meet the quality standards set forth in §143 of these regulations and in R.S. 3:1396;

4. - 5. ...

B. ...

C. Registration may be canceled by the commission if the product or registrant is found to be in violation of any statutory provisions or provisions of these regulations.

AUTHORITY NOTE: Promulgated in accordance with R.S. 3:1392 and R.S. 3:1393.

HISTORICAL NOTE: Promulgated by the Department of Agriculture, Feed Commission, LR 11:227 (March 1985), amended LR 11:944 (October 1985), amended by the Department of Agriculture and Forestry, Feed, Fertilizer, and Agricultural Liming Commission, LR 38:2526 (October 2012).

§149. Testing Required

A. The purpose of the sampling and testing requirements of this Section shall be to determine the presence of harmful materials or biological contaminants and to assure compliance with the quality standards in §143 of these regulations and R.S. 3:1396.

B. - C. ...

1. Analyses specified by the commissioner to meet the requirements of the quality standards of §143 and R.S. 3:1396 and these regulations shall be conducted on three sequential production runs to establish that the feed ingredient is consistently within the limitations specified prior to registration and/or sale of the processed animal waste product. In addition to quality standards, testing on the same production runs or lots should include potential hazardous substances such as the following:

1.a. - 3.d. ...

AUTHORITY NOTE: Promulgated in accordance with R.S. 3:1392 and R.S. 3:1398.

HISTORICAL NOTE: Promulgated by the Department of Agriculture, Feed Commission, LR 11:227 (March 1985), amended by the Department of Agriculture and Forestry, Feed, Fertilizer, and Agricultural Liming Commission, LR 38:2526 (October 2012).

§153. Fees

A. Fees for processed animal waste products shall be the same as for other animal feeds as set forth in R.S. 3:1401 and §121 of the official feed rules and regulations.

AUTHORITY NOTE: Promulgated in accordance with R.S. 3:1392 and R.S. 3:1401.

HISTORICAL NOTE: Promulgated by the Department of Agriculture, Feed Commission, LR 11:227 (March 1985), amended by the Department of Agriculture and Forestry, Feed, Fertilizer, and Agricultural Liming Commission, LR 38:2526 (October 2012).

§155. Penalties

A. Penalties for processed animal waste products will be the same as penalties for other animal feeds as set forth in R.S. 3:1400 and §123 of the official feed rules and regulations.

AUTHORITY NOTE: Promulgated in accordance with R.S. 3:1392 and R.S. 3:1400.

HISTORICAL NOTE: Promulgated by the Department of Agriculture, Feed Commission, LR 11:228 (March 1985), amended by the Feed, Fertilizer, and Agricultural Liming Commission, LR 38:2526 (October 2012).

Subchapter D. Probation of Registrants

§157. Probationary Status of Registrants

A. A registrant shall be placed on probation by the commission when 25 percent of the official samples taken from a single registrant during one complete fiscal year are found to be deficient, provided that a minimum of six samples and at least 2 percent of the total tonnage sold for that fiscal year is sampled.

B. ...

C. The commission may assess a civil penalty of not more than \$1,000 for any violation other than those found in R.S. 3:1400(A). Each day on which a violation occurs shall be considered a separate offense.

D. The commission shall not waive any penalty imposed under the provisions of R.S. 3:1391 et seq.

E.1. - E.2. ...

F. If a registrant continues to introduce products, of which the official samples' deficiency rate exceeds 20 percent, into the stream of commerce for one year, the registrant shall be summoned before the commission at its next meeting following the end of the year of probationary status to determine whether registration shall be canceled or renewal of registration shall be denied for cause.

G. The registrant shall be notified, in writing, by the commission when probationary status is terminated.

AUTHORITY NOTE: Promulgated in accordance with R.S. 3:1392 and R.S. 3:1400.

HISTORICAL NOTE: Promulgated by the Department of Agriculture, Feed Commission, LR 11:228 (March 1985), amended by the Department of Agriculture and Forestry, Feed Commission, LR 14:348 (June 1988), amended by the Department of Agriculture and Forestry, Feed, Fertilizer, and Agricultural Liming Commission, LR 38:2526 (October 2012).

§159. Cancellation of Registration and/or Denial of Application for Renewal of Registration

A. ...

B. Upon proper hearing, the commission may cancel the registration and/or deny the registrant's application for renewal of registration when any registrant fails to comply with the requirements of R.S. 3:1391 et seq., and/or these regulations promulgated under the authority therein, unless the registrant can show just cause.

C. ...

AUTHORITY NOTE: Promulgated in accordance with R.S. 3:1392 and R.S. 3:1400.

HISTORICAL NOTE: Promulgated by the Department of Agriculture, Feed Commission, LR 11:228 (March 1985), amended by the Department of Agriculture and Forestry, Feed, Fertilizer, and Agricultural Liming Commission, LR 38:2526 (October 2012).

§161. Appeals from Action of the Commission; Department of Agriculture and Forestry Appeals Concerning Method of Taking Samples

A. ...

B. If the registrant, or his agent, and the agricultural inspector who is taking the sample cannot resolve their differences, the registrant shall immediately telephone his complaint to the director of Agricultural Chemistry Programs. The registrant or his agent shall confirm the telephone complaint in writing to the same official.

C. If the difference concerning the manner of taking the sample cannot thus be resolved, the registrant may place his complaint on the agenda at the next meeting of the commission. Routine procedures for submission and analysis of the sample shall be followed pending the resolution of the differences at such hearing.

AUTHORITY NOTE: Promulgated in accordance with R.S. 3:1392 and R.S. 3:1400.

HISTORICAL NOTE: Promulgated by the Department of Agriculture, Feed Commission, LR 11:228 (March 1985), amended by the Department of Agriculture and Forestry, Feed, Fertilizer, and Agricultural Liming Commission, LR 38:2526 (October 2012).

§163. Appeals Concerning Results of Chemical Analysis

A. When a registrant, or his agent, disagrees with a finding of deficiency or a calculation of a penalty resulting from a finding of deficiency, he shall register his complaint, in writing, with the director of Agricultural Chemistry Programs within 10 days of the date of the report of chemical analysis.

B. When questions concerning the accuracy of the analysis made by the director of Agricultural Chemistry Programs cannot be amicably resolved, the registrant may place his complaint on the agenda at the next meeting of the commission for a final determination.

C. When a disagreement on a feed deficiency arises, the sample may be analyzed by an independent laboratory agreeable to the commissioner.

AUTHORITY NOTE: Promulgated in accordance with R.S. 3:1392 and R.S. 3:1400.

HISTORICAL NOTE: Promulgated by the Department of Agriculture, Feed Commission, LR 11:228 (March 1985), amended by the Department of Agriculture and Forestry, Feed, Fertilizer, and Agricultural Liming Commission, LR 38:2527 (October 2012).

§165. Appeals Concerning Probationary Status

A. Any registrant who is placed on probationary status may appeal his probation at any time by submitting to the commission a written statement on the basis of his appeal and a written request for a hearing on the matter.

B. A request for a hearing on appeal from probationary status shall not be delayed but shall be placed on the agenda for the next meeting of the commission following receipt of the request for a hearing.

AUTHORITY NOTE: Promulgated in accordance with R.S. 3:1392 and R.S. 3:1400.

HISTORICAL NOTE: Promulgated by the Department of Agriculture, Feed Commission, LR 11:228 (March 1985), amended by the Department of Agriculture and Forestry, Feed, Fertilizer, and Agricultural Liming Commission, LR 38:2527 (October 2012).

§167. Public Hearing on Cancellation of Registration/Denial of Application for Renewal of Registration

A. ...

B. When the commission determines that just cause may exist to cancel or deny renewal or registration, the commission shall give written notice to the registrant of

intent to conduct adjudicatory hearing on the matter. The notice shall be given at least 15 days prior to the date on which the hearing shall be held and shall contain all of the facts required under R.S. 49:950 et seq. The notice shall be sent by certified mail, return receipt requested, to the registrant at the last address provided by the registrant.

C. ...

D. If a controversy still exists at the conclusion of any such adjudicatory hearing called for cancellation of registration and/or denial of renewal of registration, the registrant may appeal the matter in accordance with the Administrative Procedure Act, provided that all such matters shall be lodged in the parish in which the commission is domiciled.

AUTHORITY NOTE: Promulgated in accordance with R.S. 3:1392, R.S. 3:1393 and R.S. 3:1400.

HISTORICAL NOTE: Promulgated by the Department of Agriculture, Feed Commission, LR 11:228 (March 1985), amended by the Department of Agriculture and Forestry, Feed, Fertilizer, and Agricultural Liming Commission, LR 38:2527 (October 2012).

§169. Confidentiality of Records

A. Information concerning the amount of feed sold and the business practices of registrants which is obtained from tonnage reports shall be kept confidential and shall not be revealed to the public or to other registrants by the commission, the commissioner, nor any employee of the Department of Agriculture and Forestry.

AUTHORITY NOTE: Promulgated in accordance with R.S. 3:1392 and R.S. 3:1401.

HISTORICAL NOTE: Promulgated by the Department of Agriculture, Feed Commission, LR 11:228 (March 1985), amended by the Department of Agriculture and Forestry, Feed, Fertilizer, and Agricultural Liming Commission, LR 38:2527 (October 2012).

§171. Repeal of Previously Adopted Rules and Regulations

Repealed.

AUTHORITY NOTE: Promulgated in accordance with R.S. 3:1392.

HISTORICAL NOTE: Promulgated by the Department of Agriculture, Feed Commission, LR 11:229 (March 1985), repealed by the Department of Agriculture and Forestry, Feed, Fertilizer, and Agricultural Liming Commission, LR 38:2527 (October 2012).

Part XIX. Agricultural Liming Materials

Chapter 1. General Provisions

§101. Analysis and Deficiencies

A. Analysis of lime samples shall be conducted in accordance with methods published by the Association of Official Analytical Chemists or in accordance with other generally recognized methods.

B. Liming material that, upon official analysis, is found to be deficient by 5 percent or more shall be considered as having failed to meet the standard set forth in R.S. 3:1430.8.

AUTHORITY NOTE: Promulgated in accordance with R.S. 3:1430.8(I).

HISTORICAL NOTE: Promulgated by the Department of Agriculture and Forestry, Feed, Fertilizer, and Agricultural Liming Commission, LR 38:2527 (October 2012).

Mike Strain, DVM
Commissioner

1210#017

RULE

**Department of Economic Development
Office of the Secretary
Office of Business Development
and
Louisiana Economic Development Corporation**

Economic Development Award Program (EDAP),
Economic Development Loan Program (EDLOP), and
Economic Development Site Readiness Program (EDRED)
(LAC 13:III.151, 153 and 155)

The Department of Economic Development, Office of the Secretary, Office of Business Development, and the Louisiana Economic Development Corporation, pursuant to the provisions of the Administrative Procedure Act, R.S. 49:950, et seq., and as authorized by R.S. 36:104, 36:108, 51:2302, 51:2312, and 51:2341, hereby amends, supplements and expands LAC 13:III.Chapter 1, the rules of the Economic Development Award Program (EDAP) and the Economic Development Loan Program (EDLOP), to create and regulate the Economic Development Site Readiness Program (EDRED). These rules have been approved and adopted by the board of directors of the Louisiana Economic Development Corporation.

The Department of Economic Development, Office of the Secretary, Office of Business Development and the Louisiana Economic Development Corporation have found a need to supplement and expand these rules and to adopt these new rules to create the Economic Development Site Readiness Program (EDRED), a new program that will promote economic development in the state by increasing the number and quality of sites suitable for business and industrial location and expansion, thereby increasing the state's competitiveness in securing such projects and the resulting new jobs for the state that will improve the standard of living and enrich the quality of life for citizens of the state. Without this amendment and supplement creating these new rules the state may suffer the loss of opportunity to secure such economic development projects and the resulting new jobs.

Title 13

ECONOMIC DEVELOPMENT

Part III. Financial Assistance Programs

Chapter 1. Economic Development Award Program (EDAP), Economic Development Loan Program (EDLOP) and Economic Development Site Readiness Program (EDRED)

Subchapter C. Economic Development Site Readiness Program (EDRED)

§151. Preamble and Purpose

A. A robust inventory of sites suitable for business and industrial location and expansion, having characteristics that are competitive with site offerings available in other states and availability for such projects within a short time frame, is essential to economic development in the state. Increasing the number of suitable sites, and eliminating or mitigating factors associated with these sites that can cause uncertainties and delays in project development, will

enhance the state's ability to secure these projects and thereby increase the number of jobs in the state.

B. The purpose of this program is to provide financial assistance for readying sites that will be useful in promoting the state as a business and industrial location.

AUTHORITY NOTE: Promulgated in accordance with R.S. 36:104, 36:108, 51:2302, 51:2312, and 51:2341.

HISTORICAL NOTE: Promulgated by the Department of Economic Development, Office of the Secretary, Office of Business Development and the Louisiana Economic Development Corporation, LR 38:2528 (October 2012).

§153. Definitions

LED—the Louisiana Department of Economic Development.

LEDC—the Louisiana Economic Development Corporation, acting through its board of directors.

Program—the Economic Development Site Readiness Program (EDRED).

Project—the location or expansion of a business or industrial facility in the state.

Public Site—a site which a public entity owns or for which a public entity holds an option to acquire the ownership for a project.

Site—immovable property, with or without improvements thereon, located in the state.

Site Readiness Grant—a monetary grant for the purpose of enhancing the suitability and availability of a site for a project.

AUTHORITY NOTE: Promulgated in accordance with R.S. 36:104, 36:108, 51:2302, 51:2312, and 51:2341.

HISTORICAL NOTE: Promulgated by the Department of Economic Development, Office of the Secretary, Office of Business Development, and Louisiana Economic Development Corporation, LR 38:2528 (October 2012).

§155. Site Readiness Grants

A. Pursuant to R.S. 51:2341, LEDC may award an appropriation or allocation of funds to LED, to be used for site readiness grants.

B. LED may make a site readiness grant upon terms and conditions which it determines, within its discretion, will be beneficial in meeting the goals stated in the preamble and purpose of this Subchapter.

C. Application for a site readiness grant may be made, in a form determined by LED, by the owner or lessor of a site, or by a local governmental entity or an economic development organization on behalf of the owner or lessor.

D. Eligible uses of a site readiness grant may include costs of site assessment, evaluation, preliminary engineering, environmental studies and assessments, soil analysis, wetlands delineation and mitigation, surveys, maps, due diligence, preliminary cost estimates, site preparation, site acquisition, and similar or related costs determined by LED to be beneficial in enhancing the suitability and availability of a site for a potential project.

E. Site readiness grants for non-public sites shall be limited to not more than \$1,000 per acre, unless a higher amount is approved by LEDC. This limitation shall not apply to public sites.

F. A Site readiness grant shall be made through a cooperative endeavor agreement between LED and the site owner, lessor or other applicant, which shall provide for eligible uses of the grant, obligations as to availability of the site, matching funds if any, and other terms and conditions

LED determines to be appropriate to further the purposes of this program. Grant funds may be paid to the site owner, lessor or other applicant to undertake the funded activities, or LED may use grant funds to contract with a third party to undertake such activities.

AUTHORITY NOTE: Promulgated in accordance with R.S. 36:104, 36:108, 51:2302, 51:2312, and 51:2341.

HISTORICAL NOTE: Promulgated by the Department of Economic Development, Office of the Secretary, Office of Business Development and Louisiana Economic Development Corporation, LR 38:2528 (October 2012).

Jason El Koubi
Assistant Secretary

1210#012

RULE

Office of the Governor Board of Home Inspectors

Education, Standards of Practice, Rehearing Procedure
(LAC 46:XL.119, 120, 121, 303, 305,
309, 313, 315, 319, 321, 325, and 713)

The Board of Home Inspectors has amended LAC 46:XL.119, 120, 121, 303, 305, 309, 313, 315, 319, 321, 325, and 713 in accordance with the provisions of the Administrative Procedures Act, R.S. 49:950 et seq., and the Louisiana Home Inspector Licensing Law, R.S. 37:1471 et seq. The text is being amended and adopted to revise definitions and standards of practice, to better define the requirements of education providers, and to increase the annual number of continuing education hours required. The text of §120.A has been moved and designated as §120.J. This Section has also been revised.

Title 46

PROFESSIONAL AND OCCUPATIONAL STANDARDS

Part XL. Home Inspectors

Chapter 1. General Rules

§119. Education/Training and Testing; Initial Licensure

A. Initial applicants for licensure must pass a LSBHI approved licensing examination covering home inspection methods and techniques, the standards of practice, and code of ethics.

B. ...

C. The 130 hours of home inspection instruction and training shall consist of the following:

1. 90 hours of home inspection course work approved by the board, taught by a certified pre-licensing education provider as set forth in §120;

2. 30 hours of in-field platform training from a certified infield trainer;

3. - 4. ...

D.1. The 90 hours of course work as set forth in §119.C.1 above, may only include a combination of any of the following methods of instruction:

a. ...

b. DVD, CD ROM, videotape, streaming or other electronic means of video lecture, with a certified home inspector instructor available during classroom hours for questioning and discussion;

c. - d. ...

2. No credit towards the 90 hours of course work shall be given for:

a. - d. ...

3. Before the trainee can be certified as having completed the required 90 hours of course work, the trainee must have:

a. attended and completed the 90 hours of course work within 180 days of commencement;

b. passed, with a grade of 70 percent or higher, the final examination and all periodic examinations given by the educational provider; and

c. ...

E. Before registering for the 90 hours of course work with a certified pre-licensing educational provider, the trainee must first apply with the board. After enrolling with a certified educational provider, the trainee must provide the board with the name of the provider and the commencement date of instruction.

F. Prior to admission to an infield training program, the trainee shall complete the required 90 hours of course work and pass the licensing exam described in §119.A.

G. Infield training shall consist of platform training and live training.

1. Platform training shall consist of attending 30 hours of hands-on training with a certified infield trainer at a residential structure or using residential components or equipment. All systems of a residential structure shall be examined and inspected during platform training. The applicant shall be given one credit hour for each hour of platform training attended. No more than four applicants may be trained at one time during platform training. Platform training shall not be conducted during a live home inspection where an inspection fee is paid and an inspection report is provided to a client.

2. ...

H. Upon registering trainees for a 90 hour course, all certified pre-licensing education providers shall:

1. - 2. ...

3. keep records of attendance of each trainee enrolled in the pre-licensing course to confirm satisfactory completion of the required 90 hours of instruction;

4. provide the trainee with an education provider evaluation form approved by the board prior to final testing and completion of the required 90 hours of instruction;

5. ...

6. provide a copy of certificates of completion to the board of only those trainees who have successfully completed the full 90 hours of instruction.

I. Certified infield trainers shall:

1. - 2. ...

3. issue to the trainee a certificate of completion of platform training and/or live training; and

I.4. - K. ...

AUTHORITY NOTE: Promulgated in accordance with R.S. 37:1475 and R.S. 37:1485-1487.

HISTORICAL NOTE: Promulgated by the Department of Economic Development, Board of Home Inspectors, LR 26:2741 (December 2000), amended by the Office of the Governor, Board of Home Inspectors, LR 30:1687 (August 2004), LR 35:1519 (August 2009), LR 36:2858 (December 2010), LR 38:2529 (October 2012).

§120. Education Providers; Qualifications

A.1. A *certified education provider* is defined as any individual or entity certified by the Board to provide home inspector pre-license education, in-field training and/or continuing education courses.

2. A *pre-licensing education provider* is defined as any individual or entity certified by the board to provide pre-licensing education.

3. A *continuing education provider* is defined as any individual or entity certified by the board to provide post license continuing education.

4. An *infield trainer* is defined as any individual certified by the board to provide home inspector infield training.

5. A *home inspector instructor* is defined as any individual certified by the board to provide home inspector instruction for an education provider.

6. A *guest lecturer* is defined as an individual licensed, certified and/or certified in a construction related field, who provides pre-license and/or continuing education presentations for an education provider.

B.1. Certifications issued under this Chapter shall be classified in the following categories:

- a. pre-licensing education providers;
- b. continuing education providers; and
- c. infield trainers.

2. Any individual or entity desiring to conduct business in this state as an education provider, continuing education provider or infield trainer shall file an application for certification with the board.

3. The application shall be in such form and detail as prescribed by the board.

4. The board shall approve or deny an application within 90 calendar days after it is received. Incomplete applications or a request from the board for additional information may be cause for delay beyond 90 calendar days.

5. The board may deny an application of an education provider or its director for certification for any of the following reasons.

a. The applicant has been convicted of forgery, embezzlement, obtaining money under false pretenses, larceny, extortion, conspiracy to defraud, or theft, or has been convicted of a felony or crime involving moral turpitude in any court of competent jurisdiction.

b. An application contains a false statement of material fact.

c. A professional license or certification held by an applicant or its director has been revoked.

6. The board shall issue a certificate and assign a certificate number to approved applicants that shall be included on all forms, documents, reports, and/or correspondence filed with the board.

C. Education provider certificates shall be renewed by December 31 of each year.

1. Failure to renew a certificate by December 31 shall result in the automatic suspension of all courses approved under the certificate. The board shall not accept any pre-license education, in-field training or continuing education courses for credit, if the courses were offered and/or conducted after the expiration of the certificate.

2. Applications for delinquent renewal of a certificate shall not be accepted by the board after January 31. Failure to renew an expired certificate during the prescribed delinquent period shall result in the forfeiture of renewal rights. Any education provider that becomes ineligible to renew a certificate shall apply as an initial applicant.

D.1. All education providers shall designate a director, whose duty it shall be to ensure that the operations of the education facility and all training locations adhere to the requirements of the Louisiana Home Inspector License Law and the rules and regulations of the board. The director shall be held responsible to the board for any violations thereof.

2. Directors shall coordinate and disseminate information pertaining to amendments in the license law, rules and regulations, or policies and procedures of the board to all staff, instructors, and employees of the education provider.

E.1. The board or its representative may inspect any educational facility used by an education provider at any time during regular business hours.

2. Education providers shall be subject to periodic audits and review, as determined by the board, to ensure that courses and field training provided are conducted in accordance with the provisions set forth in this Chapter and R.S. 37:1471, et seq. This may include the observation and evaluation of classroom activities, course content, instructor proficiency, and/or the audit of reporting/attendance records.

3. If the education provider is found deficient in any part of this Section, the board shall prepare a report specifying the areas of deficiency and deliver it to the education provider within 30 days of completion of the report.

4. Any education provider that receives a report of deficiencies shall correct the deficiencies by the date designated by the board and shall submit a report to the Board that outlines the corrective action.

F.1. Education providers shall maintain accurate and properly indexed records on all students for at least three years after course completion and shall produce those records for inspection upon request of the board. Electronic records shall be maintained in a readily available format that does not prohibit, delay, or otherwise impede inspection.

2. Education providers shall maintain the following records on each student:

- a. complete name and address;
- b. total educational hours taken and course title;
- c. dates of attendance;
- d. test scores indications; and
- e. a copy of the student contract.

3. Education providers shall provide any student who requests it with a duplicate copy of his/her course completion records.

G.1. Each pre-licensing education provider shall enter into a written student contract with each student that shall clearly set forth the tuition and fees charged by the provider for the specific course of instruction and the provider's refund policy.

2. A copy of the contract, signed by the director of the education provider, shall be provided to the student immediately after both parties sign the contract.

3. Any additional fees charged for supplies, materials, or required books shall be clearly itemized in the contract and such supplies, materials, or books shall become the property of the student upon payment.

4. All other educational providers shall provide the student with documentation, either electronically or otherwise, which clearly sets forth the title, date, location and cost of the course and the number of continuing education or infield training hours that are approved by the board for the course.

H. The board shall be notified within 30 calendar days of any change in the address and/or telephone number of education provider and/or director of any education provider.

I.1. Advertising by certified education providers shall be clear, concise and accurate and shall contain the certificate number of the provider. All advertisements shall be in the name of the education provider as certified by the board. Advertising by education providers shall not be false or misleading.

2. The board may require an education provider to furnish proof of any advertising claims. The board may order the retraction of advertising that violates the provisions of this Section. Such retractions shall be published in the same manner as the original claim and be paid for by the education provider.

3. Education providers shall not guarantee the passing of the home inspector licensing examination.

J.1. In order to qualify as a pre-licensing education provider, an applicant shall:

- a. pay the pre-licensing education provider fee;
- b. provide a syllabus and a course list to the board;
- c. agree, in writing, to defend, indemnify and hold the board harmless against any claim or suit alleging negligent or intentional acts or omissions of the education provider in its training, or otherwise;
- d. remain current on all renewal and other fees;
- e. employ only certified home inspector instructors; and
- f. be approved by the board.

2. In order to qualify as a certified home inspector instructor of a pre-licensing education provider, a person must:

- a. have been actively engaged in the performance of home inspections for the three years prior to certification;
- b. have been an actively engaged, Louisiana licensed home inspector for the three years prior to certification;
- c. provide evidence that he has performed at least 500 home inspections; or
- d. be licensed in the field of the subject matter of the particular course instructed.

3. In order to qualify as an infield trainer, an applicant shall:

- a. be a LSBHI licensed home inspector for at least three years;
- b. pay the required infield trainer fee(s);
- c. be current on all other fees;
- d. be current on all continuing education hours;
- e. agree, in writing, to defend, indemnify and hold the board harmless against any claim or suit alleging negligent or intentional acts or omissions of the education provider in its training, or otherwise; and

f. be approved by the board.

AUTHORITY NOTE: Promulgated in accordance with R.S. 37:1475 and R.S. 37:1485-1487.

HISTORICAL NOTE: Promulgated by the Department of Economic Development, Board of Home inspectors, LR 30:1687 (August 2004), amended by the Office of the Governor, Board of Home Inspectors, LR 31:2011 (August 2005), LR 35:1520 (August 2009), LR 36:2859 (December 2010), LR 38:2530 (October 2012).

§121. Continuing Education; Instructors

A. ...

B. Continuing Education Courses

1. - 3. ...

4. In order to receive credit for completing a continuing education course, a licensee must attend at least 90 percent of the scheduled hours of the course, regardless of the length of the course.

5. - 9. ...

10. Continuing education credit cannot be received by attending classes designated for pre-license education instruction as set forth in §119.C.1.

11. Continuing education courses must be taught by continuing education providers who meet the criteria set forth in §121.F.1. Qualified guest lecturers may teach courses on behalf of continuing education provider instructors. Last minute guest lecturers may be substituted upon approval by the chief operating officer. The continuing education provider shall be responsible for confirming the qualifications of the guest lecturer.

C.1. The board may approve online, streaming video, and other means of electronic delivery of continuing education courses. Courses taught by online education providers must be certified by the Distance Education Training Council, the International Distance Education Certification Center or the Louisiana Board of Regents and such certification must be submitted with the education provider's application.

C.2. - D.2. ...

E. It is the duty of every licensee to provide proof of compliance with continuing education requirements on a timely basis. In order to receive credit from the board for completion of continuing education courses under this Section, proof of compliance must be submitted on forms approved by the board and prepared by board-approved continuing education providers.

F.1. In order to qualify as a continuing education provider instructor, an applicant shall:

- a. ...
- b. be a licensed home inspector from a state requiring licensure for at least three years;
- c. provide evidence that he has completed 300 inspections;
- d. - e. ...

2. Professional trade organizations, accredited technical schools and colleges and certain industry companies may be approved by the board on a case by case basis as a continuing education provider without meeting the requirements set forth in Paragraph F.1 above. However, these entities must submit a completed continuing education instructor application, pay the requisite fee and meet all other requirements set forth in these rules.

3. ...

4.a. All continuing education providers must submit the following to the chief operating officer for approval at least 10 days prior to instruction:

- i. a syllabus of any course to be taught by that continuing education provider;
- ii. the requested number of continuing education credit hours for each course;
- iii. the name and qualifications of the guest lecturer teaching on his or its behalf, if applicable; and
- iv. the name and qualifications of any guest lecturer teaching on his behalf or, in the event a last minute guest lecturer is substituted, the name and qualifications of the guest lecturer are to be submitted within 10 days after the course is given.

b. The chief operating officer, with direction from the continuing education committee chairman, will determine: the number of hours credit to be given for the continuing education course submitted; whether the course is within the scope of the standards of practice; whether a guest lecturer is approved; and whether the course is approved. Once approved, the provider may teach any approved courses at his discretion.

5. All continuing education providers shall provide sign-in sheets, whether electronic or otherwise, for LHIs to complete upon entering a class, joining a streaming lecture or participating online. At the end of each class, the instructor shall provide the LHI with a certificate of completion. Sign in sheets and certificates of completion shall include the date and time of the course, the number of hours of credit assigned to each course by the board and the name of the instructor teaching the course or courses. The continuing education provider shall forward all sign-in sheets to the board immediately upon request by the board.

6. The names and contact information for all approved continuing education providers will be posted on the board's official website. At the request of a provider, the board will also post announcements of continuing education classes on its website upon written notice by the provider 30 days prior to the class.

AUTHORITY NOTE: Promulgated in accordance with R.S. 37:1477, and R.S. 37:1479-1480.

HISTORICAL NOTE: Promulgated by the Department of Economic Development, Board of Home Inspectors, LR 26:2742 (December 2000), amended by the Office of the Governor, Board of Home Inspectors, LR 36:2860 (December 2010), LR 37:2405 (August 2011), LR 38:2531 (October 2012).

Chapter 3. Standards of Practice

§303. Definitions

A. The definitions in §109 of this Part are incorporated into this Chapter by reference. The following definitions apply to this Chapter.

Roof Drainage Components—gutters, downspouts, leaders, splash blocks, scuppers, and similar components used to carry water off a roof and away from a building.

Significantly Deficient—a condition that, in the inspector's professional opinion, adversely and materially affects the performance of a system or component.

AUTHORITY NOTE: Promulgated in accordance with R.S. 37:1475.

HISTORICAL NOTE: Promulgated by the Department of Economic Development, Board of Home Inspectors, LR 26:2745 (December 2000), amended by the Office of the Governor, Board

of Home Inspectors, LR 30:1689 (August 2004), LR 36:2861 (December 2010), LR 38:2532 (October 2012).

§305. Purpose and Scope

A. ...

B. Home inspectors shall:

1. - 2. ...

3. submit a written report to the client within five days of the inspection which shall:

a. - b. ...

c. state any systems or components so inspected that, in the professional opinion of the inspector, are significantly deficient, unsafe or non-functioning; and

B.3.d. - C.4. ...

AUTHORITY NOTE: Promulgated in accordance with R.S. 37:1475.

HISTORICAL NOTE: Promulgated by the Department of Economic Development, Board of Home Inspectors, LR 26:2746 (December 2000), amended by the Office of the Governor, Board of Home Inspectors, LR 30:1690 (August 2004), LR 38:2532 (October 2012).

§309. General Exclusions

A. - A.11. ...

B. Home inspectors are not required to:

1. - 5. ...

6. disturb insulation, move personal items, panels, furniture, equipment, plant life, or other items that may obstruct access or visibility;

7. - 13. ...

14. dismantle any system or component, except as specifically required by these Standards of Practice;

15. disturb soil, snow ice, plant life, debris or personal items that may obstruct access or visibility; or

16. perform air or water intrusion tests or other tests upon roofs, windows, doors or other components of the structure to determine its resistance to air or water penetration.

C. - C.6. ...

AUTHORITY NOTE: Promulgated in accordance with R.S. 37:1475 and R.S. 37:1478.

HISTORICAL NOTE: Promulgated by the Department of Economic Development, Board of Home Inspectors, LR 26:2746 (December 2000), amended by the Office of the Governor, Board of Home Inspectors, LR 30:1690 (August 2004), LR 36:2862 (December 2010), LR 38:2532 (October 2012).

§313. Exterior System

A. The home inspector shall inspect:

1. ...

2. all doors, including garage doors and storm doors;

3. all readily accessible windows;

A.4. - C.12. ...

AUTHORITY NOTE: Promulgated in accordance with R.S. 37:1475.

HISTORICAL NOTE: Promulgated by the Department of Economic Development, Board of Home Inspectors, LR 26:2747 (December 2000), amended by the Office of the Governor, Board of Home Inspectors, LR 30:1691 (August 2004), LR 36:2862 (December 2010), LR 38:2532 (October 2012).

§315. Roofing System

A. - B.2. ...

C. The home inspector is not required to:

1. walk on the roofing;

2. inspect interiors of flues or chimneys which are not readily accessible;

3. inspect attached accessories including but not limited to solar systems, antennae, and lightning arrestors; or

4. disturb or lift roofing materials, jacks or flashing.

AUTHORITY NOTE: Promulgated in accordance with R.S. 37:1475.

HISTORICAL NOTE: Promulgated by the Department of Economic Development, Board of Home inspectors, LR 26:2747 (December 2000), amended by the Office of the Governor, Board of Home Inspectors, LR 30:1691 (August 2004), LR 36:2862 (December 2010), LR 38:2532 (October 2012).

§319. Electrical System

A. The home inspector shall inspect:

1. - 4. ...

5. the polarity and grounding of all receptacles tested; and

6. test ground fault circuit interrupters and arc fault circuit interrupters, unless, in the opinion of the inspector, such testing is likely to cause damage to any installed items or components of the home or interrupt service to an electrical device or equipment located in or around the home.

B. - E.5. ...

AUTHORITY NOTE: Promulgated in accordance with R.S. 37:1475.

HISTORICAL NOTE: Promulgated by the Department of Economic Development, Board of Home inspectors, LR 26:2748 (December 2000), amended by the Office of the Governor, Board of Home Inspectors, LR 30:1691 (August 2004), LR 36:2863 (December 2010), LR 38:2533 (October 2012).

§321. Air Conditioning and Heating System

A. - E.4.h. ...

AUTHORITY NOTE: Promulgated in accordance with R.S. 37:1475.

HISTORICAL NOTE: Promulgated by the Department of Economic Development, Board of Home inspectors, LR 26:2748 (December 2000), amended by the Office of the Governor, Board of Home Inspectors, LR 30:1692 (August 2004), LR 36:2863 (December 2010), repromulgated LR 38:2533 (October 2012).

§325. Interior System

A. The home inspector shall inspect:

1. - 3. ...

4. all doors; and

5. all readily accessible windows.

B. - B.12. ...

C. The home inspector is not required to inspect:

1. ...

2. carpeting;

3. draperies, blinds, or other window treatments; or

4. interior recreational facilities.

5. Repealed.

AUTHORITY NOTE: Promulgated in accordance with R.S. 37:1475.

HISTORICAL NOTE: Promulgated by the Department of Economic Development, Board of Home Inspectors, LR 26:2749 (December 2000), amended by the Office of the Governor, Board of Home Inspectors, LR 30:1692 (August 2004), LR 37:2406 (August 2011), LR 38:2533 (October 2012).

Chapter 7. Disciplinary Actions

§713. Hearing Procedure; Decision; Notice; Effective Date; Rehearing

A. - D.

E. A board decision or order may be reconsidered by the board at the next board meeting on its own motion, or on motion by a party of record, for good cause shown pursuant

to a written request filed at the board's office within 15 days following the decision date.

AUTHORITY NOTE: Promulgated in accordance with R.S. 37:1475, R.S. 37:1485-1487.

HISTORICAL NOTE: Promulgated by the Department of Economic Development, Board of Home inspectors, LR 26:2751 (December 2000), amended by the Office of the Governor, Board of Home Inspectors, LR 30:1695 (August 2004), LR 38:2533 (October 2012).

Albert J. Nicaud
Board Attorney

1210#021

RULE

Office of the Governor Division of Administration Patient's Compensation Fund Oversight Board

Patient's Compensation Fund (LAC 37:III.Chapters 1-19)

The Patient's Compensation Fund Oversight Board, under authority of the Louisiana Medical Malpractice Act, R.S. 40:1299.41 et seq., and in accordance with the Administrative Procedure Act, R.S. 49:950 et seq., has amended LAC 37:III to (i) clarify the Oversight Board's rules to be consistent with recently amended statutory law and current practices of the Oversight Board and the Patient's Compensation Fund; (ii) provide consistency for self-insured health care providers, those healthcare providers utilizing self-insurance trust and those healthcare provider utilizing insurance to evidence their financial responsibility; (iii) reenact several provisions that had been inadvertently repealed in the past; (iv) extend the time for which healthcare providers have in providing to the executive director notice of claims that may reasonably impact the PCF; (v) require a healthcare provider who has filed an exception of prematurity to provide a copy of the exception and the petition for damages to the board; (vi) require a claimant who has filed a petition for damages on account of medical malpractice to provide a copy of said petition for damages to the board; (vii) provide consistency between self-insured healthcare providers and those healthcare providers who are not self-insured with respect to failure to provide required reports to the board; (viii) clarify, consistent with recently amended statutory law, information to be contained, at a minimum, in a malpractice complaint; (ix) repeal unnecessary transitional rules; (x) provide for an administrative hearing process consistent with Louisiana jurisprudence and past practices of the Board related to future medical care and related benefits; and (xi) clarify payment and/or reimbursement amounts for future medical care and related benefits to be consistent with past practices of the PCF.

Title 37 INSURANCE

Part III. Patient's Compensation Fund Oversight Board

Chapter 1. General Provisions

§101. Scope

A. The rules of Part III provide for and govern the organization, administration, and defense of the Patient's Compensation Fund (the fund or PCF) by the Louisiana Patient's Compensation Fund Oversight Board (the board),

within the Division of Administration; the requirements and procedures for enrollment with the fund by qualified health care providers; the maintenance of required financial responsibility and continuing enrollment with the fund by enrolled health care providers; record keeping, accounting, and reporting of claims and claims data by the fund and enrolled health care providers; and defense of the fund and the payment of judgments, settlements and arbitration awards by the fund.

AUTHORITY NOTE: Promulgated in accordance with R.S. 40:1299.44.D(3).

HISTORICAL NOTE: Promulgated by the Office of the Governor, Patient's Compensation Fund Oversight Board, LR 18:167 (February 1992), amended by the Office of the Governor, Division of Administration, Patient's Compensation Fund Oversight Board by the Office of the Governor, Division of Administration, Patient's Compensation Fund Oversight Board, LR 38:2533 (October 2012).

§105. Patient's Compensation Fund: Description

A. The Patient's Compensation Fund is a special fund established by R.S. 40:1299.44, funded by surcharges paid by private health care providers enrolled with the fund, to provide just compensation to patients suffering loss, damages, or expense as the result of professional malpractice in the provision of health care by health care providers enrolled with the fund, as provided by and subject to the limitations of R.S. 40:1299.42. Such fund, therefore, comprises monies held in trust as a custodial fund by the board for the use, benefit, and protection of medical malpractice claimants and the fund's private health care provider members. Responsibility and authority for administration and operation of the fund including, but not limited to, the evaluating, establishing reserves against, defending, and settling claims against the fund, establishing surcharge rates or rate changes on the basis of annual actuarial studies, and administering medical review panel proceedings under R.S. 40:1299.47, is vested in the board.

AUTHORITY NOTE: Promulgated in accordance with R.S. 40:1299.44.D(3).

HISTORICAL NOTE: Promulgated by the Office of the Governor, Patient's Compensation Fund Oversight Board, LR 18:167 (February 1992), amended by the Office of the Governor, Division of Administration, Patient's Compensation Fund Oversight Board, LR 38:2534 (October 2012).

§109. General Definitions

A. As used in these rules, the following terms shall have the meanings specified:

1. - 2. ...

* * *

3. Provider Definitions

Enrolled Provider—an enrolled provider is one who has met the requirements for qualification in the Louisiana Patient's Compensation Fund (including the financial responsibility requirements of R.S. 40:1299.42) who also:

- i. is currently actively involved in medical practice and/or providing medical services in Louisiana; and
- ii. has paid the appropriate surcharge for such practice to the fund for their current policy year.

Qualified Provider—any provider who has met the statutory requirements for malpractice coverage with the Louisiana Patient's Compensation Fund. As long as the financial responsibility requirements for continued qualification in the form prescribed by §§505-509 of these

rules, as applicable, are met, a provider need not be currently enrolled in the PCF.

4. ...

* * *

AUTHORITY NOTE: Promulgated in accordance with R.S. 40:1299.44.D(3).

HISTORICAL NOTE: Promulgated by the Office of the Governor, Patient's Compensation Fund Oversight Board, LR 18:168 (February 1992), amended LR 23:68 (January 1997), LR 29:344 (March 2003), amended by the Office of the Governor, Division of Administration, Patient's Compensation Fund Oversight Board, LR 38:2534 (October 2012).

§111. Interpretive Definitions

A. As used in these rules and in the Act, the following terms are interpreted and deemed to have the meanings specified.

* * *

Chiropractor—a person holding a license to engage in the practice of chiropractic in the state of Louisiana, pursuant to R.S. 37:2801-2830, as amended.

Clinical Nurse Specialist—an advanced practice registered nurse educated in a recognized nursing specialty area who is certified according to the requirements of a nationally recognized certifying body and approved by the Louisiana State Board of Nursing, pursuant to R.S. 37:911-935, as amended.

Dentist—a person holding a license to engage in the practice of dentistry in the state of Louisiana, pursuant to R.S. 37:751-793, as amended.

* * *

Nurse Midwife—a registered nurse certified by the Louisiana State Board of Nursing as a certified nurse midwife, pursuant to R.S. 37:3240-3257, as amended.

Nurse Practitioner—an advanced practice registered nurse educated in a specified area of care and certified according to the requirements of a nationally recognized accrediting agency and approved by the Louisiana State Board of Nursing, pursuant to R.S. 37:911-935, as amended.

Nursing Home—a private home, institution, building, residence or other place, licensed or provisionally licensed by the Department of Health and Hospitals, pursuant to R.S. 40:2009.2, as amended.

* * *

Pharmacist—a person holding a certificate of registration issued by the Louisiana Board of Pharmacy pursuant to R.S. 37:1171-1183, as amended.

Physical Therapist—a person holding a license to engage in the practice of physical therapy in the state of Louisiana, pursuant to R.S. 37:2401-2422, as amended.

* * *

Psychologist—a person holding a license to engage in the practice of psychology in the state of Louisiana, pursuant to R.S. 37:2351-2367, as amended.

Registered Nurse—a person holding a license to engage in the practice of nursing in the state of Louisiana, pursuant to R.S. 37:911-935, as amended.

AUTHORITY NOTE: Promulgated in accordance with R.S. 40:1299.44.D(3).

HISTORICAL NOTE: Promulgated by the Office of the Governor, Patient's Compensation Fund Oversight Board, LR 18:168 (February 1992), amended LR 29:344 (March 2003), by the Office of the Governor, Division of Administration, Patient's Compensation Fund Oversight Board, LR 38:2534 (October 2012).

Chapter 3. Organization, Functions, and Delegations of Authority

§303. Executive Director of the Patient's Compensation Fund Oversight Board

A. The position of executive director of the Louisiana Patient's Compensation Fund Oversight Board is hereby established by the board as an unclassified position. The executive director shall be employed by the board and, subject to other provisions of law respecting qualification for and maintenance of governmental employment, hold such office at the pleasure of the board. In addition to other qualifications required by law for such office, the executive director shall be at least 21 years of age, a graduate of an accredited post-secondary college or university, and have had prior professional experience and training in insurance and actuarial science as appropriate to the executive director's responsibilities pursuant to these rules.

B. The executive director shall be responsible, and accountable to the board for the overall administration, operation, conservation, management, and defense of the fund to the extent of the responsibilities imposed on the board by the Act. Without limitation on the scope of such responsibility, the executive director shall be specifically responsible for:

1. - 9. ...

10. retention of an actuary for the fund in accordance with §701;

11. preparation and submission, in conjunction with the PCF's actuary, of the annual actuarial study and indicated surcharge rates and rate changes, to the board;

B.12. - D. ...

AUTHORITY NOTE: Promulgated in accordance with R.S. 40:1299.44.D(3).

HISTORICAL NOTE: Promulgated by the Office of the Governor, Patient's Compensation Fund Oversight Board, LR 18:169 (February 1992), amended LR 29:344 (March 2003), by the Office of the Governor, Division of Administration, Patient's Compensation Fund Oversight Board, LR 38:2535 (October 2012).

Chapter 5. Enrollment with the Fund

§505. Financial Responsibility: Insurance

A. A health care provider shall be deemed to have demonstrated the financial responsibility requisite to enrollment with the fund by submitting certification in the form of a certificate of insurance or policy declaration page that the health care provider is or will be insured on a specific date under a policy of insurance, insuring the health care provider against professional malpractice liability claims with indemnity limits of not less than \$100,000, plus interest per claim, aggregate annual indemnity limits of not less than \$300,000 plus interest for all claims arising or asserted within a 12-month policy period.

B. To be acceptable as evidence of financial responsibility pursuant to §505, an insurance policy:

1. must be issued:

a. by an insurance company admitted to do business in this state; or

b. by an unauthorized insurer which is on the list of approved unauthorized insurers maintained by the Commissioner of Insurance pursuant to R.S. 22:436 and which has:

i. a rating by A.M. Best and Co. of "A-" or higher; or

ii. a rating by Standard and Poor's of "AA-" or higher; or

iii. a rating by Moody's of "Aa" or higher; or

c. by a risk retention group organized and operating in this state pursuant to the Federal Liability Risk Retention Act of 1986, 15 U.S.C. 3901 et seq., and which has given notice of its operation within this state to the Commissioner of Insurance and is otherwise in compliance with the Louisiana Risk Retention Group Law, R.S. 22:481 et seq.; or

1.d. - 6. ...

C. The certification required by §505.A shall be issued and executed by an officer or authorized agent of the applicant health care provider's insurer and shall specifically identify the policyholder, the named insureds under such policy, the policy period, the limits of coverage, any exclusions, and any applicable deductible or uninsured retention. Upon request by the executive director, such certification shall be accompanied by a complete specimen copy of the applicable policy, or identification of the specific policy form if such form has previously been filed with and approved by the executive director.

D. ...

E. The insurance coverage required by this rule to demonstrate the requisite financial responsibility for qualification with the fund shall be deemed to be continuing without a lapse in coverage by the fund, provided that the health care provider meets the premium payment conditions of the underlying coverage and timely meets the surcharge payment conditions of §§711-713 of these rules, as applicable.

AUTHORITY NOTE: Promulgated in accordance with R.S. 40:1299.44.D(3).

HISTORICAL NOTE: Promulgated by the Office of the Governor, Patient's Compensation Fund Oversight Board, LR 18:170 (February 1992), amended LR 21:394 (April 1995), LR 23:68 (January 1997), LR 24:333 (February 1998), LR 30:1017 (May 2004), by the Office of the Governor, Division of Administration, Patient's Compensation Fund Oversight Board, LR 38:2535 (October 2012).

§507. Financial Responsibility: Self-Insurance

A. - D. ...

E.1. To maintain financial responsibility for continuing enrollment or qualification with the fund, a self-insured health care provider shall at all times maintain the unimpaired principal value of the deposit provided for by §507 at not less than \$125,000. The value of the health care provider's deposit shall be deemed impaired when any portion is seized or released pursuant to judicial process.

2. In the event that a self-insured health care provider's deposit provided for by §507 becomes impaired, the executive director shall give written notice of such impairment to the self-insured health care provider, and the self-insured health care provider shall, unless a longer period is provided for by the board, have five days from receipt of such notice to make such additional deposit as will restore the minimum deposit value prescribed by §507. A self-insured health care provider's enrollment with the fund shall terminate on and as of the later of the last day set by these rules or, if applicable, by the board, if the self-insured health care provider has not on or prior to such date restored the minimum deposit value prescribed by §507. In the case of multiple self-insured health care providers approved by the board to post one deposit, as set forth in §507.B, the

enrollment with the fund of each member of the group or each related entity shall terminate on and as of the last day set by these rules or, if applicable, by the board, if the self-insured health care provider has not on or prior to such date restored the minimum deposit value prescribed by §507.

F. A self-insured health care provider shall, within 120 days of receiving notice of a request for review of a malpractice claim, submit a report to the executive director of the anticipated exposure to the fund and the self-insured health care provider and containing sufficient details supporting the anticipated exposure. In addition, said self-insured health care provider shall provide updates to the executive director when significant changes in anticipated exposure occur.

1. - 2. Repealed.

G. A self-insured health care provider who evidences financial responsibility pursuant to §507 may, upon 45 days prior written notice to the executive director, withdraw any portion of the deposit prescribed by §507 provided that, following such withdrawal, the value of the deposit shall not be impaired.

H.1. A self-insured health care provider who has evidenced financial responsibility pursuant to §507 may withdraw the deposit prescribed by §507 upon authorization of the executive director. The security furnished as proof of financial responsibility, or a substitution which has been approved by the board, shall remain on deposit and pledged to the board during the term of the health care provider's enrollment as a self-insured health care provider with the fund and for the longer of a three-year period following termination of such enrollment or as long as any medical malpractice claim is pending, whether with the board or in a court of competent jurisdiction. After this time period, authorization may be given when the health care provider files with the executive director, not less than 30 days prior to the date such withdrawal is to be effected, a certificate signed by the health care provider, certifying:

1.a. - 2. ...

I. In the event that a health care provider's deposit becomes impaired, he shall have 30 days to make such additional deposit as will restore the minimum deposit value prescribed by §507. A health care provider's enrollment and qualification with the fund for all claims filed against the healthcare provider shall terminate on and as of the last day set by these Rules if the health care provider has not on, or prior to such date, restored the minimum deposit value prescribed by §507. In the case of multiple health care providers, as set forth in §507.B, the enrollment and qualification with the fund of each member of the group or each related entity for all claims filed against any or all of the members of the group or related entity shall terminate on and as of the last day set by these rules if the minimum deposit value prescribed by §507 has not been restored on or prior to such date.

AUTHORITY NOTE: Promulgated in accordance with R.S. 40:1299.44.D(3).

HISTORICAL NOTE: Promulgated by the Office of the Governor, Patient's Compensation Fund Oversight Board, LR 18:171 (February 1992), amended LR 18:737 (July 1992), LR 23:68 (January 1997), LR 29:344 (March 2003), by the Office of the Governor, Division of Administration, Patient's Compensation Fund Oversight Board, LR 38:2535 (October 2012).

§509. Financial Responsibility: Self-Insurance Trusts

A. The shareholders of a professional corporation, the partners of a professional partnership, a solo practitioner, a health care provider institution, or a group of such institutions may demonstrate the financial responsibility requisite to enrollment with the fund by the establishment and maintenance of a financially and actuarially sound self-insurance trust, approved by the executive director, and making and maintaining, on behalf of such trust as an entity, a deposit of not less than \$125,000 in money or represented by irrevocable letters of credit, federally-insured certificates of deposit, or in bonds or securities approved by the executive director, of the principal value of not less than \$125,000.

B.1. The following bonds and securities shall be deemed approved by the board for purposes of the deposit required by §509:

a. bonds or securities not in default as to principal or interest which are the direct obligations of, or which are secured or guaranteed as to principal and interest by full faith and credit of the United States, any state or territory of the United States, or the District of Columbia;

b. government sponsored AAA rated securities which carry an implied guarantee from the United States Government;

c. bonds or evidence of indebtedness not in default as to principal or interest which are the direct obligations of, or which are secured or guaranteed as to principal and interest by the issuing body, the state, or political subdivision of this state, or any other state or territory of the United States or the District of Columbia;

d. the bond of an authorized surety company engaged in business in the state of Louisiana which has an A.M. Best rating of A+ VIII or better. In addition, the company should meet the stated minimum rating criteria for two of the following rating services:

i. Standard and Poor AA;

ii. Duff and Phelps AA;

iii. Moody's Aa2;

e. an unconditional letter of credit with an automatic renewal provision where the issuing bank carries a commercial paper rating of P-1 by Moody's and/or an A-1 by Standard and Poor;

f. an escrow account in the name of Patient's Compensation Fund where the issuing bank carries a commercial paper rating of P-1 by Moody's and/or an A-1 by Standard and Poor.

2. In addition to the above, a self-insurance trust may apply to the board for approval of any other security which, if approved by the board, shall constitute proof of financial responsibility.

3. In addition to depositing the money or original instrument evidencing the approved security with the board, a self-insured trust shall be required to execute a pledge agreement prescribed and supplied by the executive director and to provide evidence that written notice, stating that the approved security will be pledged to the board pursuant to the terms of the pledge agreement, has been given to the issuing body.

C. Money, accounts, certificates of deposit, or other approved insurance or securities deposited, pledged or

assigned to the board pursuant to §509 shall not be assigned, transferred, sold, mortgaged, pledged, hypothecated or otherwise encumbered by the self-insurance trust nor shall any such deposit, account, or certificate of deposit be subject to writ of attachment, sequestration, or execution except pursuant to a final judgment or court-approved settlement issued or made in connection with and arising out of a malpractice claim against a member of the self-insurance trust.

D.1. To maintain financial responsibility for continuing enrollment or qualification with the fund, a self-insurance trust shall at all times maintain the unimpaired principal value of the deposit provided for by §509 at not less than \$125,000. The value of the self-insurance trust's deposit shall be deemed impaired when any portion is seized or released pursuant to judicial process.

2. In the event that a self-insurance trust's deposit provided for by §509 becomes impaired, the executive director shall give written notice of such impairment to the self-insurance trust, and the self-insurance trust shall, unless a longer period is provided by the board, have 30 days from receipt of such notice to make such additional deposit as will restore the minimum deposit value prescribed by §509. The enrollment of each member of a self-insurance trust with the fund shall terminate on and as of the last day set by these rules or, if applicable, by the board, if the self-insurance trust has not on or prior to such date restored the minimum deposit value prescribed by §509.

E. A self-insurance trust shall, within 120 days of one of its members receiving notice of a claim, submit a report of the anticipated exposure to the fund and the self-insurance trust and containing sufficient details supporting the anticipated exposure. In addition, the self-insurance trust shall provide updates to the executive director when significant changes in anticipated exposure occur.

F. A self-insurance trust approved by the executive director as evidence of financial responsibility shall be treated the same as insurance, and each health care provider covered by such a self-insurance trust shall be considered to have evidenced financial responsibility as provided in §505.

G. A self-insurance trust which evidences financial responsibility pursuant to §509 may, upon 45 days prior written notice to the executive director, withdraw any portion of the deposit prescribed by §509 provided that following such withdrawal, the value of the deposit shall not be impaired.

H.1. A self-insurance trust which has evidenced financial responsibility pursuant to §509 may withdraw the deposit prescribed by §509 upon authorization of the executive director. The security furnished as proof of financial responsibility, or a substitution which has been approved by the board, shall remain on deposit and pledged to the board during the term of the trust's members' enrollments as self-insured health care providers with the fund and for the longer of a three-year period following termination of such enrollment or as long as any medical malpractice claim is pending against the trust or any of its members, whether with the board or in a court of competent jurisdiction. After this time period, authorization may be given when the trust files with the executive director, not less than 30 days prior to the date such withdrawal is to be

effected, a certificate signed by the trustee of the trust, certifying:

a. the date that the last remaining member(s) of the trust terminated enrollment with the fund as self-insured health care provider(s);

b. that there are no medical malpractice claims against the trust or any of its members pending with the board or in a court of competent jurisdiction;

c. that there are no unpaid final judgments or settlements against or made by the trust or any of its members in connection with or arising out of a malpractice claim; and

d. that there are no unasserted medical malpractice claims which are probable of assertion against the trust or any of its members.

2. Effective as of the date on which a self-insurance trust's deposit is withdrawn pursuant to §509, the trust members' enrollment and qualification with the fund shall be terminated.

I. Application to the executive director for approval of a self-insurance trust as evidence of financial responsibility shall include:

1. identification of, by name, address, and category of each practitioner or each shareholder of an applicant professional corporation, each partner of an applicant professional partnership or each health care institution participating in the self-insurance trust;

2. a certified copy of the self-insurance trust instrument and any related organizational or operational documents;

J. The executive director shall approve of a self-insurance trust if such trust meets the requirements of the Health Care Financing Administration's (HCFA) *Medicare Provider Reimbursement Manual*, Part 1, §2162.7, related to self-insurance trusts. Those standards shall not, however, be exclusive and the executive director may approve such other qualified self-insurance trusts as appropriate, although they do not meet those requirements.

K. Each self-insurance trust approved by the executive director as evidence of financial responsibility pursuant to §509 shall be subject to audit or examination upon reasonable prior notice to the trustees thereof. Upon request by the executive director, each such trust shall, within 60 days of the conclusion of its fiscal year, file with the executive director financial statements setting forth the financial condition of the trust at the last day of the preceding year and for the year then ended, audited or reviewed by an independent certified public accountant.

L. Each self-insurance trust approved by the executive director as evidence of financial responsibility pursuant to §509 shall give written notice to the executive director within 10 days of any date that:

1. the trust instrument or other organizational or operational documents are amended; or

2. any participating member of the trust ceases to be a member or any new member begins participation with the trust

AUTHORITY NOTE: Promulgated in accordance with R.S. 40:1299.44.D(3).

HISTORICAL NOTE: Promulgated by the Office of the Governor, Patient's Compensation Fund Oversight Board, LR 18:172 (February 1992), amended LR 18:737 (July 1992), LR

23:69 (January 1997), LR 29:345 (March 2003), by the Office of the Governor, Division of Administration, Patient's Compensation Fund Oversight Board, LR 38:2536 (October 2012).

§511. Coverage: Partnerships and Professional Corporations

A. When, and during the period that, each shareholder, partner, member, agent, officer, or employee of a corporation, partnership, limited liability partnership, or limited liability company, who is eligible for qualification as a health care provider under the Act, and who is providing health care on behalf of such corporation, partnership, or limited liability company, is enrolled with the fund as a health care provider, having paid the applicable surcharges due the fund and demonstrated and maintained financial responsibility in accordance with the standards prescribed by §§503-511 for enrollment of such individual, such corporation, partnership, limited liability partnership, or limited liability company shall, without the payment of an additional surcharge, be deemed concurrently qualified and enrolled as a health care provider with the fund when, and during the period that such corporation, partnership, limited liability partnership, or limited liability company demonstrates and maintains financial responsibility in accordance with the standards prescribed by §§503-511. Any such corporation, partnership, limited liability partnership, or limited liability company which fails to provide proof of financial responsibility upon request of the fund after the filing of a request for review of a claim under R.S. 40:1299.47 or after the filing of a lawsuit alleging medical malpractice, shall not be deemed concurrently qualified and enrolled as a health care provider under this Part.

B. The corporation, partnership, limited liability partnership, or limited liability company shall furnish to the board, concurrently with its enrollment and renewal application, the name(s) of each shareholder, partner, member, agent, officer, or employee who is eligible for qualification and enrollment with the fund as a health care provider and evidence of its financial responsibility in accordance with the standards prescribed by §§503-511.

AUTHORITY NOTE: Promulgated in accordance with R.S. 40:1299.44.D(3).

HISTORICAL NOTE: Promulgated by the Office of the Governor, Patient's Compensation Fund Oversight Board, LR 18:173 (February 1992), amended LR 29:345 (March 2003), LR 30:1017 (May 2004), by the Office of the Governor, Division of Administration, Patient's Compensation Fund Oversight Board, LR 38:2538 (October 2012).

§513. Enrollment Procedure

A. ...

B. The application shall be accompanied by evidence of financial responsibility in the form prescribed by §§505-509 of these rules, as applicable, and the applicable surcharge.

C. If the executive director determines that an applicant is not eligible for enrollment with the fund, he shall notify the applicant within 15 days of receipt of the completed application. The applicant may, within 15 days of receipt of the notice, appeal the determination to the board by mailing notice of said appeal to the executive director. If appealed timely, the matter shall be placed on the agenda of the next meeting of the board, at which time the board may hear such evidence as it deems appropriate and uphold or reverse the decision of the executive director. The decision of the board shall be final.

AUTHORITY NOTE: Promulgated in accordance with R.S. 40:1299.44.D(3).

HISTORICAL NOTE: Promulgated by the Office of the Governor, Patient's Compensation Fund Oversight Board, LR 18:173 (February 1992), by the Office of the Governor, Division of Administration, Patient's Compensation Fund Oversight Board, LR 38:2538 (October 2012).

§515. Certification of Enrollment

A. ...

B. Duplicate or additional certificates of enrollment shall be available to and upon the request of an enrolled health care provider or his or its attorney, or professional liability insurance underwriter when such certification is required to evidence enrollment or qualification with the fund in connection with an actual or proposed malpractice claim against the health care provider.

AUTHORITY NOTE: Promulgated in accordance with R.S. 40:1299.44.D(3).

HISTORICAL NOTE: Promulgated by the Office of the Governor, Patient's Compensation Fund Oversight Board, LR 18:173 (February 1992), amended LR 23:69 (January 1997), LR 29:346 (March 2003), LR 30:1018 (May 2004), by the Office of the Governor, Division of Administration, Patient's Compensation Fund Oversight Board, LR 38:2538 (October 2012).

§517. Expiration, Renewal of Enrollment

A. Enrollment with the fund expires:

1. as to a health care provider evidencing financial responsibility by certification of insurance pursuant to §505 of these rules, on and as of:

a. the effective date and time of termination or cancellation of the policy of the health care provider's professional liability insurance coverage; or

b. the last day of the applicable period for which the prior annual surcharge applied in the event that the annual surcharge for renewal coverage is not paid by the health care provider to the insurer on or before 30 days following the expiration of the prior enrollment period.

2. as to a health care provider evidencing financial responsibility pursuant to §§507-509 of these rules, on and as of:

a. the effective date and time of termination, cancellation or impairment of the health care provider's financial responsibility; or

b. the last day of the applicable period for which the prior annual surcharge applied in the event that the annual surcharge for renewal coverage is not paid by the health care provider to the board or to the self-insurance trust on or before 30 days following the expiration of the prior enrollment period.

B. Enrollment with the fund must be annually renewed by each enrolled health care provider on or before expiration of the enrollment period by submitting to the executive director an application for renewal, upon forms supplied by the executive director, and payment of the applicable surcharge in accordance with the rules hereof providing for the fund's billing and collection of surcharges from insured and self-insured health care providers. Each insured health care provider shall cause the insurer to submit a certificate of insurance to the executive director along with the application for renewal. Each self-insured health care provider and each health care provider covered by a self-insurance trust shall submit, along with the application for renewal, original

documents which indicate that the health care provider's deposit with the board is current and/or not in default.

AUTHORITY NOTE: Promulgated in accordance with R.S. 40:1299.44.D(3).

HISTORICAL NOTE: Promulgated by the Office of the Governor, Patient's Compensation Fund Oversight Board, LR 18:174 (February 1992), amended LR 29:346 (March 2003), repromulgated LR 29:579 (April 2003), by the Office of the Governor, Division of Administration, Patient's Compensation Fund Oversight Board, LR 38:2538 (October 2012).

§519. Cancellation, Termination of Enrollment

A. A health care provider's enrollment with the fund for all claims filed against the healthcare provider shall be canceled and terminated:

1. as to a health care provider evidencing financial responsibility by certification of insurance pursuant to §505 of these rules, on and as the effective date of cancellation of the health care provider's professional liability insurance coverage;

2. as to a health care provider evidencing financial responsibility pursuant to §§507-509 of these rules, on and as of any date on which:

a. the health care provider or self-insurance trust, as applicable, ceases to maintain financial responsibility in the amount and form prescribed by these rules; or

b. the health care provider or self-insurance trust, as applicable, fails, within the allowed time after notice by the executive director, to provide additional security for financial responsibility when existing financial responsibility security is impaired all as provided in §§507-509 of these rules.

3. on any date that the health care provider's professional or institutional license, certification, or registration is suspended or revoked or that the health care provider ceases to be a health care provider as defined by the Act and these rules or otherwise ceases to be eligible for enrollment hereunder.

B. Upon written notice to a health care provider, the executive director may cancel and terminate a health care provider's enrollment with the fund, effective 30 days following the mailing by registered or certified mail, return receipt requested, or giving of such notice in the event that an enrolled health care provider has failed or refused to timely provide any reports or submit any information or data required to be reported or submitted by these rules, including but not limited to those provided for in §1101. If, within 30 days of receipt of such a notice, a health care provider furnishes to the board any and all delinquent reports, information, and data, as specified by such notice, the health care provider's enrollment with the fund may be continued in effect.

AUTHORITY NOTE: Promulgated in accordance with R.S. 40:1299.44D.(3).

HISTORICAL NOTE: Promulgated by the Office of the Governor, Patient's Compensation Fund Oversight Board, LR 18:174 (February 1992), repealed LR 29:346 (March 2003), amended by the Office of the Governor, Division of Administration, Patient's Compensation Fund Oversight Board, LR 38:2539 (October 2012).

Chapter 7. Surcharges

§711. Payment of Surcharges: Insurers and Self-Insurance Trusts

A. Applicable surcharges for enrollment and qualification with the fund shall be collected on behalf of the

board by commercial professional health care liability insurance companies and approved self-insurance trusts from insured health care providers electing to enroll and qualify with the fund. Such surcharges shall be collected by such insurers and trusts at the same time and on the same basis as such insurers' and trust's collection of premiums or contributions from such insureds. Surcharges collected by such insurers and trusts on behalf of the board shall be due and payable and remitted to the board by such insurers and trusts within 30 days from the date on which such surcharges are collected from any insured health care provider.

B. ...

C. Failure of the commercial professional health care liability insurers, agents of the insurer, risk manager, or surplus line agent, and approved self-insurance trust funds to remit payment within 30 days of collecting such annual surcharge may subject the commercial professional liability insurers, commercial insurance underwriters, and approved self-insurance trust funds to a penalty, the amount of which will be set by the board on an annual basis, not to exceed 12 percent of the annual surcharge, and all reasonable attorney fees. Upon the failure of the commercial professional health care liability insurers, commercial insurance underwriters and approved self-insurance trust funds to remit as provided in §711, the board may institute legal proceedings to collect the surcharge, together with penalties, legal interest, and all reasonable attorney fees.

D. - E. ...

AUTHORITY NOTE: Promulgated in accordance with R.S. 40:1299.44.D(3).

HISTORICAL NOTE: Promulgated by the Office of the Governor, Patient's Compensation Fund Oversight Board, LR 18:176 (February 1992), amended LR 20:432 (April 1994), LR 23:69 (January 1997), LR 29:346 (March 2003), amended by the Division of Administration, Patient's Compensation Fund Oversight Board, LR 36:2558 (November 2010), by the Office of the Governor, Division of Administration, Patient's Compensation Fund Oversight Board, LR 38:2539 (October 2012).

§715. Amount of Surcharges; Form of Coverage;

Conversions

A. A health care provider qualified for enrollment by evidence of liability insurance pursuant to §505, or by evidence of participation in an approved self-insurance trust pursuant to §509, shall pay the most recently approved rate which is applicable to his provider type, years enrolled in the fund, and which most closely corresponds to the class and form of coverage of said primary liability insurance or self-insurance trust. The form of coverage provided by the board shall be identical to that provided by the qualifying policy of insurance or self-insurance except where the policy conflicts with applicable law or regulation.

B. A health care provider qualified for enrollment by evidence of self-insurance pursuant to §507 shall pay the most recently approved fund surcharge amount which is applicable to self-insured coverage and to his provider type. The form of coverage provided by the fund shall be self-insured coverage as defined in §109.A of these rules.

C.1. When a health care provider who had previously purchased claims-made coverage from the board elects to purchase occurrence coverage from or discontinue enrollment in the fund, he shall not have coverage afforded by the fund for any claims arising from acts or omissions occurring during the fund's claims-made coverage but

asserted after the termination of the claims-made coverage unless he evidences financial responsibility for those claims either by purchasing an extended reporting endorsement or posting a deposit with the board pursuant to §507 and pays, on or before 45 days following the termination of the claims-made coverage, the surcharge applicable to fund tail coverage for the corresponding claims-made period(s).

2. When a health care provider who had previously purchased claims-made coverage from the board elects to purchase self-insured coverage from the fund, he shall not have coverage afforded for any claims arising from acts or omissions occurring during the fund's claims-made coverage but asserted after the termination of the claims-made coverage, unless he evidences financial responsibility for those claims either by purchasing an extended reporting endorsement or posting a second deposit with the board pursuant to §507 and pays, on or before 45 days following the termination of the claims-made coverage, the surcharge applicable to fund tail coverage for the corresponding claims-made period(s).

3. In special circumstances, the executive director or board may, at its discretion, waive or defer the payment of an additional surcharge and allow tail coverage to a provider without the payment of the applicable-surcharge. Each such case requires an individual written request for relief to the board, and will be decided on individual circumstances. The board's criteria for such decisions shall include, but not be limited to:

- a. the reason for such request;
- b. the length and basis of the provider's enrollment with the fund;
- c. the potential claims liability to the fund;
- d. the provider's intention to cease or continue to practice in Louisiana; and
- e. the potential effects if the fund refuses to allow such relief.

D. When a health care provider who had previously purchased claims-made coverage from the fund permanently retires from the practice of medicine after 10 consecutive years of enrollment, or when an institutional provider and any successors who had previously purchased claims-made coverage from the fund permanently ceases to do business and/or practice medicine after 10 consecutive years of coverage, or when a health care provider who had previously purchased claims-made from the board dies or becomes permanently disabled, then the surcharge to the board for tail coverage for claims occurring during the existence of the fund claims-made coverage shall be considered to have been paid. However, continuous PCF coverage under this rule shall only apply if the affected provider or institution maintains continuous financial responsibility either through insurance coverage or submission of the security required for self-insurance under §507, including underlying insurance tail coverage, for the primary \$100,000 for each claim. Further, this rule shall only apply to the successor of an institutional provider to the extent that the predecessor business entity was enrolled, and only to the single business entity which had been previously enrolled. This rule shall not apply to other business entities of the successor provider.

AUTHORITY NOTE: Promulgated in accordance with R.S. 40:1299.44.D(3).

HISTORICAL NOTE: Promulgated by the Office of the Governor, Patient's Compensation Fund Oversight Board, LR 23:69 (January 1997), amended LR 29:347 (March 2003), LR 30:1018 (May 2004), by the Office of the Governor, Division of Administration, Patient's Compensation Fund Oversight Board, LR 38:2539 (October 2012).

Chapter 9. Scope of Coverage

§901. Effective Date

A. A health care provider who qualifies for enrollment with the fund by demonstrating financial responsibility through professional liability insurance pursuant to §505 of these rules or by participation in an approved self-insurance trust pursuant to §509 of these rules, shall be deemed to become and be enrolled with the fund effective as of the date on which the surcharge payable by or on behalf of such health care provider is timely collected in accordance with §711 hereof and the applicable policies and procedures of the insurer or trust for premium payments. If such surcharge is not timely collected, the effective date of enrollment with the fund shall be the date on which such surcharge is paid to the fund, the insurer, agent or trust.

B. A health care provider who qualifies for enrollment with the fund by demonstrating financial responsibility by self-insurance pursuant to §507 of these rules, shall be deemed to become and be enrolled with the fund effective as of the date on which the surcharge payable by or on behalf of such health care provider is timely collected by the board in accordance with §713 hereof. If such surcharge is not timely collected, the effective date of enrollment with the fund shall be the date on which such surcharge is collected or accepted by the board.

AUTHORITY NOTE: Promulgated in accordance with R.S. 40:1299.44.D(3).

HISTORICAL NOTE: Promulgated by the Office of the Governor, Patient's Compensation Fund Oversight Board, LR 18:176 (February 1992), amended LR 23:70 (January 1997), LR 29:347 (March 2003), by the Office of the Governor, Division of Administration, Patient's Compensation Fund Oversight Board, LR 38:2540 (October 2012).

§903. Term of Enrollment

A. The enrollment of a health care provider qualified for enrollment by evidence of liability insurance pursuant to §505 hereof shall expire on and as of the earlier of the date on which the policy period of the insurance policy evidencing such financial responsibility expires or not more than one year from the date on which such health care provider's enrollment became effective.

B. The enrollment of a health care provider qualified for enrollment by evidence of self-insurance pursuant to §507 hereof shall expire not more than one year from the date on which such health care provider's enrollment became effective.

C. The enrollment of a health care provider qualified for enrollment by evidence of participation in approved self-insurance trust pursuant to §509 of these rules shall expire on and as of the earlier of the date on which the health care provider ceases to be a participating member of such trust or not more than one year from the date on which such health care provider's enrollment became effective.

AUTHORITY NOTE: Promulgated in accordance with R.S. 40:1299.44.D(3).

HISTORICAL NOTE: Promulgated by the Office of the Governor, Patient's Compensation Fund Oversight Board, LR

18:177 (February 1992), by the Office of the Governor, Division of Administration, Patient's Compensation Fund Oversight Board, LR 38:2540 (October 2012).

§905. Scope of Coverage: Insureds

A. With respect to health care providers enrolled with the fund by evidence of liability insurance pursuant to §505 hereof, subject to the limitation of liability prescribed by the Act, the fund shall be liable for compensation for claims asserted against the health care provider only within the scope of coverage afforded by, and subject to the limitations and exclusions of, the policy of professional liability insurance evidencing the health care provider's financial responsibility and subject to the payment of the applicable surcharges.

AUTHORITY NOTE: Promulgated in accordance with R.S. 40:1299.44.D(3).

HISTORICAL NOTE: Promulgated by the Office of the Governor, Patient's Compensation Fund Oversight Board, LR 18:177 (February 1992), by the Office of the Governor, Division of Administration, Patient's Compensation Fund Oversight Board, LR 38:2541 (October 2012).

§907. Scope of Coverage: Self-Insureds

A. With respect to health care providers enrolled with the fund by evidence of self-insurance pursuant to §507 hereof, the fund shall be obligated to pay compensation to the extent provided by the Act only with respect to claims arising from an incident which occurred during the effective period of enrollment, regardless of whether the provider was actively enrolled on the date on which the claim was reported, so long as the provider continues to meet the financial responsibility requirements of R.S. 40:1299.42 for continued qualification.

B. The fund's obligation for compensation shall extend to the vicarious liability of an enrolled health care provider for acts or omissions of any employee or agent of the provider when acting within the course and scope of his or her employment, except any employee individually eligible for enrollment with the fund employed by the health care provider when such employed person is not enrolled with the fund. The fund's obligation for compensation does not and shall not extend to any liability or obligation of a health care provider, which the health care provider has assumed or undertaken by contract or agreement, to indemnify, defend or hold harmless any other person, firm or corporation.

AUTHORITY NOTE: Promulgated in accordance with R.S. 40:1299.44.D(3).

HISTORICAL NOTE: Promulgated by the Office of the Governor, Patient's Compensation Fund Oversight Board, LR 18:177 (February 1992), amended LR 23:70 (January 1997), by the Office of the Governor, Division of Administration, Patient's Compensation Fund Oversight Board, LR 38:2541 (October 2012).

§909. Scope of Coverage: Self-Insurance Trusts

A. With respect to health care providers enrolled with the fund by evidence of participation in an approved self-insurance trust pursuant to §509 hereof, subject to the limitation of liability prescribed by the Act, the fund shall be liable for compensation for claims asserted against the health care provider only within the scope of coverage afforded by, and subject to the limitations and exclusions of, the self-insurance trust instrument evidencing the health care provider's financial responsibility and subject to the payment of the applicable surcharges.

AUTHORITY NOTE: Promulgated in accordance with R.S. 40:1299.44.D(3).

HISTORICAL NOTE: Promulgated by the Office of the Governor, Patient's Compensation Fund Oversight Board, LR 18:177 (February 1992), by the Office of the Governor, Division of Administration, Patient's Compensation Fund Oversight Board, LR 38:2541 (October 2012).

Chapter 11. Reporting

§1101. Notice of Claims, Reserves, Proposed Settlement

A. Within 90 days of the date on which a malpractice claim is asserted, or of the date on which a claim that may reasonably impact the fund becomes probable of assertion, against an enrolled health care provider, the health care provider, or the health care provider's liability insurer, shall give notice of such claim to the executive director, if the executive director has not previously received notice of the claim or medical review panel request. Such notice shall include identification of the person or persons asserting the claim, the nature of the claim, the circumstances surrounding and the date or dates of the occurrences giving rise to the claim. Such notice shall also advise of the name and address of the attorney at law, if any, retained by the health care provider or his or its insurer to represent the health care provider in defense of the claim. If an attorney has not been retained by the health care provider or insurer at the time of such notice, notice shall thereafter be given to the executive director within 10 days of the retention of an attorney to represent the health care provider.

B. Upon the assertion of a claim that may reasonably exceed the limitation of liability afforded the health care provider under the Act against an insured health care provider enrolled with the fund or against a self-insured health care provider which establishes reserves against individual claims, the health care provider or his or its insurer, as the case may be, shall promptly give notice to the executive director of the amount of indemnity that has been established and allocated to the claim by the health care provider or insurer. Within 30 days of the adjustment or modification of any such reserve, a health care provider or insurer shall give notice of such adjustment or modification to the executive director.

C. Each health care provider enrolled with the fund, or the insurer of an enrolled health care provider on behalf of such health care provider, shall give not less than 10 days prior written notice to the executive director of any proposed compromise or settlement of a malpractice claim asserted against the health care provider.

D. Within 20 days of the receipt of a malpractice claim against an enrolled health care provider in the form of a lawsuit, the health care provider, or the health care provider's liability insurer, shall furnish a copy of the lawsuit to the PCF. The health care provider, or the health care provider's liability insurer, shall also furnish to the PCF within 20 days of receipt, a copy of all amending pleadings related to the lawsuit. In any civil action or proceeding in which a health care provider files a dilatory exception of prematurity pursuant to Code of Civil Procedure Article 926(A)(1), said health care provider shall send a copy of the exception and the petition for damages to the board, via certified mail, return receipt requested, concurrently with serving the parties to the civil action or proceeding.

E. Upon filing a petition for damages in court for bodily injuries to or death of a patient on account of medical malpractice, the claimant shall send, by certified mail, return receipt requested, a copy of said petition for damages to the

board. The claimant shall also provide written notice to the board of the trial date in such proceeding.

AUTHORITY NOTE: Promulgated in accordance with R.S. 40:1299.44.D(3).

HISTORICAL NOTE: Promulgated by the Office of the Governor, Patient's Compensation Fund Oversight Board, LR 18:177 (February 1992), amended LR 29:348 (March 2003), by the Office of the Governor, Division of Administration, Patient's Compensation Fund Oversight Board, LR 38:2541 (October 2012).

§1103. Claims Experience Reporting: Insurers, Institutions and Self-Insured

A. On or before August 1 of each year, each insurance company, approved risk retention group, and approved self-insurance trust fund then providing professional health care liability insurance to any health care providers enrolled with the fund, and each enrolled self-insured health care provider shall file with the fund, through the executive director, a summary of the health care liability claims experience of such health care provider or insurer fully developed for each of the most recently concluded 5 calendar years or for such fewer years as the health care provider or insurer has engaged in business in the state. Claims experience data filed by insurance companies shall include data for all health care providers insured by such insurer in the state and enrolled with the fund.

B. The reports required by this rule shall contain such information and data and shall be made and filed upon and in accordance with such forms, instructions, and array as may be specified and supplied by the executive director, all of which shall be distributed to those required to report no later than the preceding April 1.

AUTHORITY NOTE: Promulgated in accordance with R.S. 40:1299.44.D(3).

HISTORICAL NOTE: Promulgated by the Office of the Governor, Patient's Compensation Fund Oversight Board, LR 18:178 (February 1992), by the Office of the Governor, Division of Administration, Patient's Compensation Fund Oversight Board, LR 38:2542 (October 2012).

§1105. Noncompliance; Failure to Report

A. Noncompliance with the reporting and notice requirements prescribed by these rules shall be deemed adequate and sufficient legal grounds for the cancellation and termination of enrollment of any enrollee of the fund. The executive director shall give written notice via certified mail to any health care provider and if applicable, the insurer or trust which, being required to provide reports under these rules, fails to do so within the time specified. The enrollment of a health care provider who does not submit, or have submitted by his insurer, trust or legal representative, the required reports in proper form may be terminated 30 days following the mailing of such notice by the executive director if the health care provider has not before such date filed the required reports in proper form.

B. Noncompliance with the reporting and notice requirements prescribed by these rules shall be deemed adequate and sufficient legal grounds for the cancellation and termination of the enrollment of any self-insured health care provider, approved risk retention group or self-insurance trust failing or refusing to report as required by these rules. The executive director shall give written notice by certified mail to any self-insured health care provider which, being required to provide reports under these rules, fails to do so within the time specified. The

enrollment of a health care provider who does not submit the required reports in proper form may be terminated 30 days following the mailing of such notice by the executive director if the health care provider has not before such date filed the required reports in proper form.

AUTHORITY NOTE: Promulgated in accordance with R.S. 40:1299.44.D(3).

HISTORICAL NOTE: Promulgated by the Office of the Governor, Patient's Compensation Fund Oversight Board, LR 18:178 (February 1992), by the Office of the Governor, Division of Administration, Patient's Compensation Fund Oversight Board, LR 38:2542 (October 2012).

§1107. Confidentiality

A. All reports, notices, communications, information, records, and data made or given to the executive director, the board or to their agents or contractors pursuant to the provisions of Chapter 11 shall be deemed privileged and confidential by and in the possession of the executive director, the board and/or their agents and contractors, and unless ordered by a court of competent jurisdiction after a contradictory hearing, shall not be disclosed to any third party pursuant to request, subpoena, or otherwise without the express written authorization and consent of the person, office, or entity making or giving, or originally possessing any such reports, notices, communications, information, records, or data. This rule shall not, however, prohibit disclosure or publication after prior consent of the board of aggregated information or data from which information or data relative to individual health care providers may not be discerned.

AUTHORITY NOTE: Promulgated in accordance with R.S. 40:1299.44.D(3).

HISTORICAL NOTE: Promulgated by the Office of the Governor, Patient's Compensation Fund Oversight Board, LR 18:178 (February 1992), by the Office of the Governor, Division of Administration, Patient's Compensation Fund Oversight Board, LR 38:2542 (October 2012).

Chapter 13. Fund Data Collection, Maintenance; Accounting and Reporting

§1301. Fund Data Collection, Maintenance

A. All information and data collected by or reported to the board relating to the administration, operation, or defense of the fund shall be recorded and maintained by the board. All of such information and data shall, to the extent reasonably possible, be electronically computer database stored and maintained so as to be readily and efficiently accessible for utilization in the processing of applications for enrollment, in establishment and adjustment of claim reserves and reserves for incurred but not reported claims, in the preparation and analysis of claims experience data in connection with the development of surcharge rate filings, and in the defense of the fund.

AUTHORITY NOTE: Promulgated in accordance with R.S. 40:1299.44.D(3).

HISTORICAL NOTE: Promulgated by the Office of the Governor, Patient's Compensation Fund Oversight Board, LR 18:178 (February 1992), by the Office of the Governor, Division of Administration, Patient's Compensation Fund Oversight Board, LR 38:2542 (October 2012).

§1303. Fund Accounting

A. The executive director shall be responsible for maintaining accounts and records for the board as may be necessary and appropriate to accurately reflect the financial condition of the fund on a continuing basis.

AUTHORITY NOTE: Promulgated in accordance with R.S. 40:1299.44.D(3).

HISTORICAL NOTE: Promulgated by the Office of the Governor, Patient's Compensation Fund Oversight Board, LR 18:178 (February 1992), by the Office of the Governor, Division of Administration, Patient's Compensation Fund Oversight Board, LR 38:2542 (October 2012).

§1305. Annual Budget

A. The executive director shall annually project revenue and expense budgets for the fund for the succeeding fiscal year in accordance with the provisions of R.S. 40:1299.44(A)(5)(f). Such budget shall reflect all revenues projected to be collected or received by or accruing to the fund during such fiscal year, together with the projected expenses of the administration, operation, and defense of the fund and satisfaction of its liabilities and obligations. Such budgets shall be submitted to the board for its approval, and as approved by the board, submitted on or before the following January 1 to the joint legislative committee on the budget, Senate Judiciary A, House Civil Law and Procedures, Legislative Auditor, Division of Administration and the legislative fiscal office, in accordance with R.S. 40:1299.44(A)(5)(f).

AUTHORITY NOTE: Promulgated in accordance with R.S. 40:1299.44.D(3).

HISTORICAL NOTE: Promulgated by the Office of the Governor, Patient's Compensation Fund Oversight Board, LR 18:178 (February 1992), by the Office of the Governor, Division of Administration, Patient's Compensation Fund Oversight Board, LR 38:2543 (October 2012).

§1307. Appropriation Request

Repealed.

AUTHORITY NOTE: Promulgated in accordance with R.S. 40:1299.44.D(3).

HISTORICAL NOTE: Promulgated by the Office of the Governor, Patient's Compensation Fund Oversight Board, LR 18:179 (February 1992), repealed by the Office of the Governor, Division of Administration, Patient's Compensation Fund Oversight Board, LR 38:2543 (October 2012).

§1309. Periodic Reports

A. The executive director shall prepare or cause to be prepared statements of the financial condition of the fund at least quarterly and shall post such reports on the board's website. Such statement may be prepared, at the election of the executive director, in accordance with generally accepted accounting principles relating to accounting for governmental funds.

AUTHORITY NOTE: Promulgated in accordance with R.S. 40:1299.44.D(3).

HISTORICAL NOTE: Promulgated by the Office of the Governor, Patient's Compensation Fund Oversight Board, LR 18:179 (February 1992), by the Office of the Governor, Division of Administration, Patient's Compensation Fund Oversight Board, LR 38:2543 (October 2012).

§1311. Annual Report

A. Each year, the executive director shall cause to be prepared an annual statement of the financial condition of the fund, which statement shall be in the form of the annual report required to be filed by the Division of Administration and the Legislative Auditor. Such statement shall be submitted to the board, Division of Administration and the legislative auditor. Such statement shall be a public record and posted on the board's website.

AUTHORITY NOTE: Promulgated in accordance with R.S. 40:1299.44.D(3).

HISTORICAL NOTE: Promulgated by the Office of the Governor, Patient's Compensation Fund Oversight Board, LR 18:179 (February 1992), amended LR 19:204 (February 1993), by the Office of the Governor, Division of Administration, Patient's Compensation Fund Oversight Board, LR 38:2543 (October 2012).

Chapter 14. Medical Review Panels

§1401. Procedure

A. Except as otherwise provided by the Act, all malpractice claims against health care providers shall be reviewed by a medical review panel. The composition and operation of a medical review panel shall be in accordance with R.S. 40:1299.47.

AUTHORITY NOTE: Promulgated in accordance with R.S. 40:1299.44.D(3).

HISTORICAL NOTE: Promulgated by the Office of the Governor, Patient's Compensation Fund Oversight Board, LR 29:348 (March 2003), by the Office of the Governor, Division of Administration, Patient's Compensation Fund Oversight Board, LR 38:2543 (October 2012).

§1403. Malpractice Complaint

A. A "request for review of a malpractice claim" or "malpractice complaint" shall contain, at a minimum:

1. a request for the formation of a medical review panel;
2. full name of only one patient for whom, or on whose behalf, the request for review is being filed; however, if the claim involves the care of a pregnant mother and her unborn child, then naming only the mother as the patient shall be sufficient;
3. full name(s) of the claimant(s);
4. full name(s) of defendant health care providers;
5. date(s) of alleged malpractice;
6. brief description of alleged malpractice as to each named defendant; and
7. brief description of alleged injuries.

B. The request for review of a malpractice claim shall be deemed filed on the date of receipt of the complaint stamped and certified by the board or on the date of mailing of the complaint if mailed to the board by certified or registered mail.

C. Within 15 days of receiving a malpractice complaint, the board shall:

1. confirm to the claimant that the malpractice complaint has been officially received and whether or not the named defendant(s) are qualified for the malpractice claim;
2. notify all named defendant(s) that a malpractice complaint requesting the formation of a medical review panel has been filed against them and forward a copy of the malpractice complaint to each named defendant at his last and usual place of residence or his office;
3. if the malpractice complaint does not contain all of the required information set forth in paragraph (A) of this section, notify the claimant(s) that the malpractice complaint has been received but does not comply with this section and indicate what additional information is required and a reasonable time limit for submitting such additional information; and
4. notify the claimant(s) if verification of employment or renewal of fund coverage must be obtained for a named

defendant health care provider for fund qualification to be determined.

AUTHORITY NOTE: Promulgated in accordance with R.S. 40:1299.44.D(3).

HISTORICAL NOTE: Promulgated by the Office of the Governor, Patient's Compensation Fund Oversight Board, LR 29:348 (March 2003), by the Office of the Governor, Division of Administration, Patient's Compensation Fund Oversight Board, LR 38:2543 (October 2012).

§1405. Attorney Chairman

A. An attorney chairman of a medical review panel is to be chosen by the parties according to R.S. 40:1299.47.(A)(2)(c). An attorney chairman must be selected within one year from the date the request for review of the claim was filed. If, after one year, an attorney chairman has not been secured, the board shall send notice by certified mail to the claimant or the claimant's attorney stating that the claim will be dismissed after 90 days if no attorney chairman is appointed. If no attorney chairman is selected within 90 days of the certified notice, the board shall dismiss the claim.

AUTHORITY NOTE: Promulgated in accordance with R.S. 40:1299.44.D(3).

HISTORICAL NOTE: Promulgated by the Office of the Governor, Patient's Compensation Fund Oversight Board, LR 29:348 (March 2003), by the Office of the Governor, Division of Administration, Patient's Compensation Fund Oversight Board, LR 38:2544 (October 2012).

Chapter 15. Defense of the Fund

§1501. Claims Defense

A. Through its executive director, the board shall be responsible for the administration and processing of claims against and legal defense of claims against the fund. The executive director shall be responsible, and accountable to the board, for coordination and management of defense of the fund against claims to the extent of the responsibilities imposed on the board by the Act. Without limitation on the scope of such responsibility, the executive director shall be responsible for:

1. evaluating all malpractice claims made under the Act against enrolled health care providers to the potential liability of the fund;
2. recommending, fixing, establishing, and periodically modifying, as required, appropriate reserves against claims made against enrolled health care providers or the fund, subject to the approval of the board;
3. retaining, subject to qualifications and standards prescribed by the board, and supervising the services of attorneys at law to defend the fund against claims;
4. review and approval of fee and costs statements for services rendered by attorneys at law retained to defend the fund, ensuring that such statements accurately reflect services reasonably necessary or appropriate to the defense of the fund;
5. supervision and coordination of the defense of claims against or involving the fund by attorneys retained and representing enrolled health care providers;
6. negotiating and recommending reasonable and appropriate compromises and settlements of the fund's liability respecting any claim against the fund;
7. maintenance of current, accurate, and complete records and data on all pending and concluded claims against or involving the fund;

8. retaining an appropriately qualified claims manager or principal assistant and delegating to such claims manager those duties and responsibilities as deemed appropriate by the executive director; and

9. the discharge and performance of such other duties, responsibilities, functions, and activities as are delegated by the board.

B. All authority for the defense of the fund vested in the board by the Act is hereby delegated to the executive director. In the exercise of such authority, the executive director shall be accountable to, and subject to the superseding authority of, the board.

AUTHORITY NOTE: Promulgated in accordance with R.S. 40:1299.44.D(3).

HISTORICAL NOTE: Promulgated by the Office of the Governor, Patient's Compensation Fund Oversight Board, LR 18:179 (February 1992), amended LR 29:348 (March 2003), by the Office of the Governor, Division of Administration, Patient's Compensation Fund Oversight Board, LR 38:2544 (October 2012).

§1503. Claims Accounting

A. All expenses incurred in the legal defense, disposition, payment on individual claims, judgments, or settlements shall be accounted for and allocated among such respective claims.

AUTHORITY NOTE: Promulgated in accordance with R.S. 40:1299.44.D(3).

HISTORICAL NOTE: Promulgated by the Office of the Governor, Patient's Compensation Fund Oversight Board, LR 18:179 (February 1992), amended LR 29:348 (March 2003), by the Office of the Governor, Division of Administration, Patient's Compensation Fund Oversight Board, LR 38:2544 (October 2012).

§1505. Claim Reserves

A. Within 30 days of receipt of notice of a claim against or potentially involving liability of the fund, the board may establish a reserve against such claim representing the total amount of compensation and compensation adjustment expenses which the fund is anticipated to be liable for and incur in respect of and allocable to such claim. Reserves respecting individual claims against the fund shall be established in consultation, as appropriate, with legal counsel representing the board with respect to such claim, with legal counsel for the enrolled health care providers against whom the claim is primarily asserted, and with claims personnel managing such claim for the commercial insurers of the enrolled health care providers against whom the claim is asserted. Reserves respecting individual claims against the fund shall be adjusted from time to time as changing circumstances or evaluations may warrant.

AUTHORITY NOTE: Promulgated in accordance with R.S. 40:1299.44.D(3).

HISTORICAL NOTE: Promulgated by the Office of the Governor, Patient's Compensation Fund Oversight Board, LR 18:180 (February 1992), amended LR 29:349 (March 2003), by the Office of the Governor, Division of Administration, Patient's Compensation Fund Oversight Board, LR 38:2544 (October 2012).

§1507. Settlement of Claims

A. Claims against the fund may be compromised and settled upon the recommendation of the executive director and the approval of the board. The executive director shall, however, have authority, without the necessity of prior approval by the board, to compromise and settle any individual claim against the fund for an amount not exceeding \$25,000.

AUTHORITY NOTE: Promulgated in accordance with R.S. 40:1299.44.D(3).

HISTORICAL NOTE: Promulgated by the Office of the Governor, Patient's Compensation Fund Oversight Board, LR 18:180 (February 1992), amended LR 29:349 (March 2003), by the Office of the Governor, Division of Administration, Patient's Compensation Fund Oversight Board, LR 38:2544 (October 2012).

§1509. Privileged Communications, Records

A. All communications made and documents, records, and data developed between, by, or among the board, executive director, Office of Risk Management, PCF general counsel, the Attorney General or his representative, contracted legal counsel, and enrolled health care providers and their insurers respecting malpractice claims asserted against enrolled health care providers or the fund shall be deemed privileged and confidential and, unless so ordered by a court of competent jurisdiction after a contradictory hearing, shall not be disclosed to any third party pursuant to request, subpoena, or otherwise, without the express written authorization and consent of the person, office, or entity making any such communication or originally possessing any such documents, records, or data. This rule shall not, however, prohibit disclosure or publication by the board of aggregated information or data from which information or data relative to individual health care providers or individual claims may not be discerned.

AUTHORITY NOTE: Promulgated in accordance with R.S. 40:1299.44.D(3).

HISTORICAL NOTE: Promulgated by the Office of the Governor Patient's Compensation Fund Oversight Board, LR 18:180 (February 1992), by the Office of the Governor, Division of Administration, Patient's Compensation Fund Oversight Board, LR 38:2545 (October 2012).

Chapter 17. Transitional Rules

§1701. Continuing Enrollment of Self-Insureds

Repealed.

AUTHORITY NOTE: Promulgated in accordance with R.S. 40:1299.44.D(3).

HISTORICAL NOTE: Promulgated by the Office of the Governor, Patient's Compensation Fund Oversight Board, LR 18:180 (February 1992), repealed by the Office of the Governor, Division of Administration, Patient's Compensation Fund Oversight Board, LR 38:2545 (October 2012).

§1703. Continuing Enrollment of Self-Insurance Trusts

Repealed.

AUTHORITY NOTE: Promulgated in accordance with R.S. 40:1299.44.D(3).

HISTORICAL NOTE: Promulgated by the Office of the Governor, Patient's Compensation Fund Oversight Board, LR 18:180 (February 1992), repealed by the Office of the Governor, Division of Administration, Patient's Compensation Fund Oversight Board, LR 38:2545 (October 2012).

Chapter 19. Future Medical Care and Related Benefits

§1901. Scope of Chapter

A. The rules of Chapter 19 provide for and govern the administration and payment by the fund of future medical care and related benefits for patients deemed to be in need of future care and related benefits pursuant to a final judgment issued by a court of competent jurisdiction or agreed to in a settlement reached between a patient and the board.

B. The rules of Chapter 19 shall be applicable to all malpractice claims, including those brought under R.S. 40:1299.39.

AUTHORITY NOTE: Promulgated in accordance with R.S. 40:1299.44.D(3).

HISTORICAL NOTE: Promulgated by the Office of the Governor, Patient's Compensation Fund Oversight Board, LR 19:1566 (December 1993), amended LR 27:1888 (November 2001), by the Office of the Governor, Division of Administration, Patient's Compensation Fund Oversight Board, LR 38:2545 (October 2012).

§1903. Definitions

Administrative Hearing—hearing held in response to a request or complaint by a patient in need of future medical care or his/her representative, that the fund has failed or refused to pay for medical care or related benefits. The hearing shall be conducted before at least three board members.

Future Medical Care and Related Benefits—all reasonable medical, surgical, hospitalization, physical rehabilitation, and custodial services, and includes drugs, prosthetic devices, and other similar materials reasonably necessary in the provision of such services. The fund's obligation to provide these benefits or to reimburse the claimant for those benefits is limited to the lesser of the amount billed therefor or the maximum amount allowed under the reimbursement schedule.

Reimbursement Schedule—the most recent reimbursement schedules promulgated by the Department of Labor, Office of Workers' Compensation pursuant to R.S. 23:1034.2.

AUTHORITY NOTE: Promulgated in accordance with R.S. 40:1299.44.D(3).

HISTORICAL NOTE: Promulgated by the Office of the Governor, Patient's Compensation Fund Oversight Board, LR 19:1566 (December 1993), amended LR 27:1888 (November 2001), by the Office of the Governor, Division of Administration, Patient's Compensation Fund Oversight Board, LR 38:2545 (October 2012).

§1905. Obligation of the Fund

A. The fund shall provide and/or fund the cost of all future medical care and related benefits in the amounts provided herein, after the date of the accident and continuing as long as medical or surgical attention is reasonably necessary, that are made necessary by the health care provider's malpractice, pursuant to a final judgment issued by a court of competent jurisdiction or as agreed to in a settlement reached between a patient and the fund, unless the patient refuses to allow the future medical care and related benefits to be furnished.

B. The fund acknowledges that a court is required neither to choose the best medical treatment nor the most cost-efficient treatment for a patient. The intent of Chapter 19 is to distinguish between those devices which are reasonably necessary to a patient's treatment and those which are devices of convenience or non-essential specialty items for a patient, and to provide for the maximum allowable reimbursement for those necessary future medical care and related benefits. However, the fund shall not pay for repairs for or replacement of durable medical equipment, vehicles or residential modifications or renovations.

C. Pursuant to the Act, the board has been, expressly and/or implicitly, vested with the responsibility and authority for the management, administration, operation, and defense of the fund and, as a prudent administrator, it must insure that all future medical care costs and related benefits are

reasonable and commensurate with the usual and customary costs of such care in the patient's community. Therefore, the amount paid by the fund for future medical care and related benefits shall be the lesser of the amount billed for said care or benefit or the maximum amount allowed under the reimbursement schedule.

D. Payments for future medical care and related benefits shall be paid by the fund without regard to the \$500,000 limitation imposed in R.S. 40:1299.42.

AUTHORITY NOTE: Promulgated in accordance with R.S. 40:1299.44.D(3).

HISTORICAL NOTE: Promulgated by the Office of the Governor, Patient's Compensation Fund Oversight Board, LR 19:1566 (December 1993), amended LR 27:1888 (November 2001), by the Office of the Governor, Division of Administration, Patient's Compensation Fund Oversight Board, LR 38:2545 (October 2012).

§1907. Claims for Future Medical Care and Related Benefits

A. A patient, who is deemed to be in need of future medical care and related benefits pursuant to a final judgment issued by a court of competent jurisdiction or as agreed to in a settlement reached between the patient and the fund, may make a claim to the fund through the board for future medical care and related benefits as incurred by the patient and made necessary by the health care provider's malpractice.

B. If a patient's claim for future medical care and related benefits is disputed or payment of the amount thereof has been denied by the board, then the matter may be referred to the board for an administrative hearing.

C.1. The following administrative hearing process shall be followed when such is requested by the claimant or the claimant's representative. The claimant desiring to institute a hearing shall prepare and file with the board a complaint setting forth:

a. the name and address of each respondent;

b. a statement, in ordinary and concise language, of the facts upon which the complaint is based, together with supporting evidentiary material, including but not limited to, whenever applicable, particular reference to the statute or statutes, or rules, regulations, and orders that the claimant alleges have been violated.

2. Such complaint will be sent to the general counsel for the board who will contact all parties to determine the date of the hearing. The hearing panel will consist of at least three board members. The parties may provide any evidence they deem necessary and may call witnesses to give testimony that bears upon the issues. A court reporter will be present to record the hearing and to administer the necessary oaths to any witnesses. Each party will be allowed to make a brief opening statement, present evidence and cross-examine any witnesses. The panel members will be allowed to ask questions of both parties and any witnesses. All parties will be allowed to make a closing statement. Following the closing statements, the panel members will meet in private to reach a decision. Findings of fact and decision of the panel will be put in written form and presented to the board in executive session for a final determination and vote. The final decision will be forwarded to the claimant or their representative and the fund's counsel.

3. Should the claimant or their representative disagree with the decision reached through the administrative hearing process, they may file a petition in the 19th judicial district court in accordance with §1931 of these rules.

AUTHORITY NOTE: Promulgated in accordance with R.S. 40:1299.44.D(3).

HISTORICAL NOTE: Promulgated by the Office of the Governor, Patient's Compensation Fund Oversight Board, LR 19:1566 (December 1993), amended LR 27:1889 (November 2001), by the Office of the Governor, Division of Administration, Patient's Compensation Fund Oversight Board, LR 38:2546 (October 2012).

§1909. Attorneys; Medical Experts; Architects; Adjusters

A.1. An attorney chosen to represent the fund pursuant to §1907 shall be an independent contractor, shall meet all applicable requirements for an outside contractor retained by the state of Louisiana, and shall be chosen by the executive director or his designee. The attorney shall be licensed to practice law in the state of Louisiana.

2. Once a matter involving future medical care and related benefits is referred to an attorney, then the attorney shall be responsible for the matter to the extent of the assignment. The attorney shall issue status reports to the claims adjuster at least every 90 days until the matter is concluded.

3. The attorney chosen to represent the fund may recommend any and all possible remedies to the fund and may hire or retain experts, subject to prior approval by the fund. The attorney shall utilize legal staff, including paralegals, nurse/paramedical personnel, clerks, and investigators, where necessary. With prior approval from the claims supervisor, the attorney may appoint a case manager in cases where no case manager has been appointed.

B. Medical experts may be retained directly by the fund for evaluation, diagnosis, or with patient consent or by court order, for treatment of the patient. All medical experts retained by the fund shall be licensed or otherwise certified by the state of Louisiana. However, consulting physicians, licensed to practice in states other than Louisiana, may be retained by the fund only if they are board-certified in the applicable area of specialty.

C. Architects with special expertise in medical facility design, contractors, and other building trade experts may be retained directly by the fund in future medical care cases involving issues of residential modifications or renovations. Architects retained by the fund shall be licensed by the state of Louisiana. Contractors retained by the fund shall be licensed or certified as general contractors by the state of Louisiana. Architects and contractors retained by the fund shall also possess experience in the design and construction of medical facility and/or barrier free residences.

AUTHORITY NOTE: Promulgated in accordance with R.S. 40:1299.44.D(3).

HISTORICAL NOTE: Promulgated by the Office of the Governor, Patient's Compensation Fund Oversight Board, LR 19:1566 (December 1993), amended LR 27:1889 (November 2001), by the Office of the Governor, Division of Administration, Patient's Compensation Fund Oversight Board, LR 38:2546 (October 2012).

§1911. Examinations; Notice Requirements

A. The fund shall be entitled to have a patient submit to a physical or mental examination, by a health care provider of

the fund's choice, from time to time, to determine the patient's continued need of future medical care and related benefits, or the level of medical care needed, subject to the following requirements.

A.1. - E. ...

AUTHORITY NOTE: Promulgated in accordance with R.S. 40:1299.44.D(3).

HISTORICAL NOTE: Promulgated by the Office of the Governor, Patient's Compensation Fund Oversight Board, LR19:1567 (December 1993), amended LR 27:1889 (November 2001), by the Office of the Governor, Division of Administration, Patient's Compensation Fund Oversight Board, LR 38:2546 (October 2012).

§1917. Nursing Care; Sitter Care

A. The fund will provide and/or fund, at the lesser of the billed amount or the maximum amount allowed under the reimbursement schedule, inpatient or outpatient nursing or sitter care when such care is required to provide reasonable medical, surgical, hospitalization, physical rehabilitation, or custodial services made necessary by the health care provider's malpractice, subject to the following limitations.

1. All nursing or sitter care shall be specifically prescribed or ordered by a patient's treating health care provider.

2. All nursing or sitter care shall be rendered by a licensed and/or qualified registered nurse or licensed practical nurse or by a sitter, a member of the patient's family or household, or other person as specifically approved by the fund.

3. There shall be a presumption that the person rendering nursing or sitter care is qualified if the treating health care provider issues a statement that that person is competent and qualified to render the nursing or sitter care required by the patient.

4. All claims for nursing or sitter care payments, including those for family members providing such care, must include a signed, detailed statement by the person rendering nursing or sitter care, setting forth the date, time, and type of care rendered to and for the patient.

B.1. Providers of nursing or sitter care shall be funded, at the lesser of the billed amount or the maximum amount allowed under the reimbursement schedule. If the reimbursement schedule contains no applicable rate for such care, then the care shall be funded at the lesser of the billed amount or the usual and customary rate charged by similarly licensed or qualified healthcare providers in a patient's home state, city, or town. However, nursing or sitter care provided by members of the patient's family or household will be funded at a rate not to be less than the federal minimum hourly wage rate as may be revised from time to time regardless of the licensure or qualification of the provider.

2. However, notwithstanding the foregoing, future nursing or sitter care provided by members of the patient's family or household will be funded at a rate not to exceed the equivalent of \$6 per hour plus inflation at the annual consumer price index published by the United States Bureau of Labor Statistics for each year beginning in November 2001. However, at no time will the hourly rate paid be below the federal minimum hourly wage rate as may be revised from time to time.

C. - D. ...

AUTHORITY NOTE: Promulgated in accordance with R.S. 40:1299.44.D(3).

HISTORICAL NOTE: Promulgated by the Office of the Governor, Patient's Compensation Fund Oversight Board, LR 19:1567 (December 1993), amended LR 27:1889 (November 2001), by the Office of the Governor, Division of Administration, Patient's Compensation Fund Oversight Board, LR 38:2547 (October 2012).

§1919. Treatment Protocol

A. In cases where the future medical needs of the patient are so great that multi-disciplinary, long-term acute care is needed by the patient, and the patient and/or the patient's family, tutor, legal guardian or care givers are deemed to be incapable of determining what treatment is necessary, then the fund may retain a case manager to develop a treatment protocol for the patient. The patient, or the person legally responsible for the patient, will be provided with a copy of the written treatment protocol and will be asked to consent to the treatment or course of treatment proposed by the protocol prior to implementation of the protocol.

AUTHORITY NOTE: Promulgated in accordance with R.S. 40:1299.44.D(3).

HISTORICAL NOTE: Promulgated by the Office of the Governor, Patient's Compensation Fund Oversight Board, LR 19:1568 (December 1993), by the Office of the Governor, Division of Administration, Patient's Compensation Fund Oversight Board, LR 38:2547 (October 2012).

§1921. Vehicles

A. The fund will provide and/or fund the cost of standard modified vehicles or specialized modified vehicles to patients entitled to receive future medical care and related benefits under §1921, when ownership and use of such vehicles are reasonably necessary in providing reasonable medical, surgical, hospitalization, physical rehabilitation, or custodial services made necessary by the health care provider's malpractice. The vehicles described herein are standard model, modified passenger vehicles of domestic manufacture or standard model, modified vans of domestic manufacture. Alternatively, and at the fund's option, the fund will provide and/or fund modifications to the patient's vehicle when such modifications are reasonably necessary in the provision of such services.

B. The choice of vehicle, vendor of the vehicle, modifications thereto, and inclusion or exclusion of option items on these vehicles will be at the sole discretion of the fund.

C. The fund will not provide nor fund the cost of any type of insurance for any such vehicle and will not provide nor fund the maintenance or operating costs on any vehicle modified by the fund or provided by the fund. The fund will fund repairs to the handicap modifications to the vehicle, unless such damage was intentional.

AUTHORITY NOTE: Promulgated in accordance with R.S. 40:1299.44.D(3).

HISTORICAL NOTE: Promulgated by the Office of the Governor, Patient's Compensation Fund Oversight Board, LR 19:1568 (December 1993), by the Office of the Governor, Division of Administration, Patient's Compensation Fund Oversight Board, LR 38:2547 (October 2012).

§1923. Ancillary Cost; Mileage

A. - C. ...

D. Patients shall provide actual receipts or signed statements verifying the reasonable mileage for odometer readings to receive reimbursements pursuant to §1923. Expenses for hotel /motel accommodations and meals associated with physician appointments or treatment shall

not be reimbursed without prior approval by the fund. In addition, all such reimbursements shall be made in accordance with State Travel Regulations in force at the time of the travel.

AUTHORITY NOTE: Promulgated in accordance with R.S. 40:1299.44.D(3).

HISTORICAL NOTE: Promulgated by the Office of the Governor, Patient's Compensation Fund Oversight Board, LR 19:1568 (December 1993), amended LR 27:1889 (November 2001), by the Office of the Governor, Division of Administration, Patient's Compensation Fund Oversight Board, LR 38:2547 (October 2012).

§1925. Modifications/Renovations to Patient's

Residence

A. The fund will provide and/or fund the cost of modifications to a patient's residence which are reasonably necessary in providing reasonable medical, physical rehabilitation, and custodial services for the patient and which are made necessary by the health care provider's malpractice. The fund will not provide nor fund the cost of devices of convenience.

B. Upon request by the patient and/or the patient's family or care givers for modifications, there will be a meeting with the claims manager to determine specifically what modifications should be made to the home. The claims manager and the architect chosen by the fund will then review the medical report(s), and then meet to determine what action will be taken as to the modifications of the home, within the specific guidelines listed below.

1. The fund will provide and/or fund the cost of modifications or renovations to the patient's existing home including, but not limited to, modifications of lavatories, including handicap accessible toilets, showers, ramps for ingress and egress, expanded doorways, and expansion of rooms to accommodate medical devices required by the patient, which are reasonably necessary for the care and rehabilitation of the patient and in accordance with the American with Disabilities Act and other applicable handicap accessibility standards.

2. All renovations and/or modifications will be designed and built with builders spec or similar grade materials from plans drawn and/or approved by an architect obtained by the fund. The fund will determine the amount to be paid by the fund based on the architect's recommendations and proposals obtained from reputable contractors. Any deviations from this amount must be preapproved by the fund or borne by the patient or claimant, as applicable.

3. When the fund has provided and/or funded modifications or renovations to the home where the patient resides, the fund shall retain no interest in that residence. Where the home is owned by the patient's parents, relatives, care givers, or guardian, the fund reserves the right to require the owners of the home to execute a promissory note, mortgage, or other instrument of security in favor of the patient in an amount equal to the increased value of the home, as determined by a qualified appraiser retained by the fund.

AUTHORITY NOTE: Promulgated in accordance with R.S. 40:1299.44.D(3).

HISTORICAL NOTE: Promulgated by the Office of the Governor, Patient's Compensation Fund Oversight Board, LR 19:1568 (December 1993), by the Office of the Governor, Division of Administration, Patient's Compensation Fund Oversight Board, LR 38:2548 (October 2012).

§1931. Attorney Fees

A. Following the completion of the administrative hearing process hereunder, pursuant to its continuing jurisdiction, the district court, from which a final judgment has been issued in cases where future medical care and related benefits have been determined to be needed by a patient, shall award reasonable attorney fees to the patient's attorney if the court finds that the fund unreasonably failed to pay for medical care and related benefits within 30 days after submission of a claim for payment of such benefits.

B. ...

AUTHORITY NOTE: Promulgated in accordance with R.S. 40:1299.44.D(3).

HISTORICAL NOTE: Promulgated by the Office of the Governor, Patient's Compensation Fund Oversight Board, LR 19:1569 (December 1993), by the Office of the Governor, Division of Administration, Patient's Compensation Fund Oversight Board, LR 38:2548 (October 2012).

Lorraine LeBlanc
Executive Director

1210#043

RULE

Office of the Governor Division of Administration Racing Commission

Field Less Than Five (LAC 35:XIII.11115)

The Louisiana State Racing Commission amends Field Less Than Five (LAC 35:XIII.11115) as follows.

Title 35.

HORSE RACING Part XIII. Wagering

Chapter 111. Trifecta

§11115. Field Less Than Five

A. Trifecta wagering will be permitted when the number of wagering interests in a thoroughbred or quarter horse race is five or more. A late scratch after wagering begins on that race will not cancel trifecta wagering.

B. The commission may approve trifecta wagering on a race with a purse value of \$200,000 or more where the number of wagering interests is less than five.

AUTHORITY NOTE: Promulgated in accordance with R.S. 4:149, R.S. 4:149.1 and R.S. 4:149.2.

HISTORICAL NOTE: Promulgated by the Department of Commerce, Racing Commission, LR 11:616 (June 1985), amended by the Department of Economic Development, Racing Commission, LR 18:366 (April 1992), LR 22:13 (January 1996), LR 25:25 (January 1999), amended by the Office of the Governor, Division of Administration, Racing Commission, LR 38:2548 (October 2012).

Charles A. Gardiner III
Executive Director

1210#026

RULE

**Office of the Governor
Division of Administration
Racing Commission**

Superfecta (LAC 35:XIII.11701)

The Louisiana State Racing Commission has amended Superfecta (LAC 35:XIII.11701) as follows

Title 35.

HORSE RACING

Part XIII. Wagering

Chapter 117. Superfecta

§11701. Superfecta

A. - J. ...

K. The minimum number of wagering interests required to offer Superfecta wagering shall be six. A late scratch after wagering begins on that race will not cancel Superfecta wagering.

L. The commission may approve Superfecta wagering on a race with a purse of \$200,000 or more where the number of wagering interests is less than six.

M. - O. ...

AUTHORITY NOTE: Promulgated in accordance with R.S. 4:149-149.3.

HISTORICAL NOTE: Promulgated by the Department of Economic Development, Racing Commission, LR 22:805 (September 1996), amended by the Office of the Governor, Division of Administration, Racing Commission, LR 38:2549 (October 2012).

Charles A. Gardiner III
Executive Director

1210#027

RULE

**Department of Health and Hospitals
Board of Nursing**

Procedure for Establishing a New Program
(LAC 46:XLVII.3533)

In accordance with the provisions of the Administrative Procedure Act, R.S. 49:950 et seq., and through the authority granted in R.S. 37:918, that the Louisiana State Board of Nursing has amended Chapter 35 of its rules, in particular, by amending Section 3533 of the board's rules to include E.3, to set forth what occurs when a program has been continued on initial approval for two years but has failed to demonstrate eligibility for obtaining full approval. This action is deemed necessary because, while the boards rules respecting nursing education programs currently provide that a nursing education program shall not be placed on initial approval for more than two consecutive one-year periods following its eligibility to apply for full approval, the rules are currently silent regarding what occurs upon the lapse of the two years when a program has failed to demonstrate eligibility for obtaining full approval, including making no provision for due process considerations nor permitting the board to extend the period for initial approval where the facts may warrant such action. The current Rule, which is an amendment to Section 3533, has been promulgated in order

to address this silence within the rules and also to provide for a procedure and related matters.

Title 46

**PROFESSIONAL AND OCCUPATIONAL
STANDARDS**

Part XLVII. Nurses

Subpart 2. Registered Nurses

Chapter 35. Nursing Education Programs

§3533. Procedure for Establishing a New Program

A. - E.2. ...

3. Notwithstanding LAC 46:XLVII.3509.A.2 and 3533.E.2, a program that has failed to achieve full approval within two years following the program's eligibility to apply for full approval shall submit a report to the board noting the reasons for such failure. The board shall thereafter issue a rule to show cause order, requiring the program to appear before the board for a hearing, after which the board may do either of the following:

a. grant the program up to an additional one year period of initial approval post eligibility for full approval. At or before the end of the extended initial approval, if the program has met the standards for full approval, it may petition the board for full approval. If the program remains ineligible for full approval at the end of the extended initial approval, the program shall initiate a phase out of the program as outlined in LAC 46:XLVII.3533.E.3.b; or

b. terminate the program, requiring it to deny admission to any new students in the nursing sequence and to initiate a phase out of the program as outlined below.

i. A plan to phase out the existing nursing program shall include:

(a). dateline for final admission of students to the existing program;

(b). plan for the normal progression of students in the existing program;

(c). contingency plan for students who cannot follow the normal progression sequence in the existing program (i.e., failures, illness, etc); and

(d). the projected date of graduation for the final class of the existing program.

ii. All students shall have assistance with transfers to the new nursing programs or to another program of choice. A list of the names of these students shall be submitted to the board.

iii. The following records of the existing program shall be retained:

(a). students' applications to the program (when applicable);

(b). students' final transcripts;

(c). all curricula plans offered, including catalog course descriptions;

(d). rosters of all graduation classes and dates of graduations.

iv. The board shall be notified of the arrangements for the administrative control and safe storage of the permanent program and student records.

AUTHORITY NOTE: Promulgated in accordance with R.S. 37:918.

HISTORICAL NOTE: Promulgated by the Department of Health and Human Resources, Board of Nursing, LR 3:190 (April 1977), amended LR 10:1027 (December 1984), amended by the Department of Health and Hospitals, Board of Nursing, LR 14:532 (August 1988), repromulgated LR 24:1293 (July 1998), amended

Barbara L. Morvant
Executive Director

1210#025

RULE

**Department of Public Safety and Corrections
Office of State Police**

Motor Vehicle Inspections (LAC 55:III.Chapters 7 and 8)

The Department of Public Safety and Corrections, Office of State Police, in accordance with R.S. 49:950 et seq., Act 138 of the 2009 Regular Session, and R.S. 32:1304 et seq., hereby promulgates amended rules providing for replacement of the fine schedule, replacing references to the non-existent Safety Enforcement Section with new references to the Department of Public Safety, and other miscellaneous amendments.

Title 55

PUBLIC SAFETY

Part III. Motor Vehicles

**Chapter 7. Louisiana Motor Vehicle Safety
Inspection Program**

§701. Penalties for Non Compliance

A. - A.3. ...

4. Civil penalties shall be assessed as described in R.S. 32:1312.

5. If an inspection station or mechanic inspector receives three written violation notices within a 12-month period, this shall be grounds to remove said inspection station or mechanic inspector from the Motor Vehicle Safety Inspection Program. This in no way intends to impede the ability of the department from removing an inspection station or mechanic inspector at any time with proper cause.

6. The Office of State Police shall impose civil penalties after affording the accused an opportunity for a fair and impartial hearing to be held in accordance with the Administrative Procedures Act.

7. After the hearing process has been exhausted and upon the decision of the department to impose civil penalties has been upheld, civil penalties shall be imposed as previously stated.

8. All licensees and applicants shall be current in the payment of all penalties and fees owed to the Department of Public Safety. Companies failing to comply with this requirement are subject to having their station's license suspended or revoked.

AUTHORITY NOTE: Promulgated in accordance with R.S. 32:1310 and 32:1312 et seq.

HISTORICAL NOTE: Promulgated by the Department of Public Safety and Corrections, Office of State Police, LR 21:184 (February 1995), amended LR 38:2550 (October 2012).

Chapter 8. Motor Vehicle Inspection

Subchapter A. General

§801. Definitions

A. As used in this Chapter, the following terms have the meanings described below.

Department—Department of Public Safety and Corrections, Office of State Police, Department of Public Safety Police.

* * *

AUTHORITY NOTE: Promulgated in accordance with R.S. 32:1304-1310.

HISTORICAL NOTE: Promulgated by the Department of Public Safety and Corrections, Office of State Police, Safety Enforcement Section LR 25:2421 (December 1999), amended LR 38:2550 (October 2012).

§803. Foreword

A.-D. ...

E. Each official motor vehicle inspection station shall give priority to customers seeking motor vehicle inspections. Reasonable time shall be considered when the inspector is committed to other duties, (clean up, hazardous situation).

AUTHORITY NOTE: Promulgated in accordance with R.S. 32:1304-1310.

HISTORICAL NOTE: Promulgated by the Department of Public Safety and Corrections, Office of State Police, Safety Enforcement Section, LR 25:2421 (December 1999), amended LR 38:2550 (October 2012).

Subchapter B. Safety Inspections

§805. Requirements, Duties, Responsibilities

A. - A.1.d. ...

e. stations inspecting commercial vehicles and school buses are required to have special authorization from the department.

2. Dealer Station. Any person, association or corporation licensed as a dealer of vehicles which are subject to registration may be licensed as an official MVI dealer inspection station. These stations may only conduct inspections of both new and used vehicles owned by the dealer which are for sale or demonstration. A notation will be made in the remarks section of the application form indicating what type of vehicles is to be inspected. When a dealer is authorized to inspect, it is mandatory that all vehicles sold as new or used must be properly inspected and a valid inspection certificate affixed thereto as prescribed by the official rules and regulations under LAC 55:III.Chapters 7 and 8.

3. ...

4. Government Station. A town, municipality, city, parish or state agency to which the department has granted authority to inspect vehicles owned and registered to these government agencies. These stations will not be approved unless they have their own repair shop; a school board may be granted authority to inspect and certify vehicles operated or contracted by that board.

5. Non-attainment area stations are inspection stations receiving specialized training and licensing. Only non-attainment area stations are permitted to inspect vehicles registered within this area. The nonattainment area consists of five parishes. These parishes are designated by the four digit domicile code on the registration. Domicile codes beginning with 03 (Ascension Parish), 17 (East Baton Rouge), 24 (Iberville Parish), 32 (Livingston Parish), or 61 (West Baton Rouge) are within the non-attainment area.

B. Request for Appointment as an Official Inspection Station

1. A written request must be submitted to the department in the district where the business is located in order to become an official MVI station. A representative of

the department will be assigned to inspect the premises and interview the personnel to determine that all minimum requirements are met.

2. ...

C. Minimum Requirements for a Motor Vehicle Inspection Station

1. The following minimum requirements must be met prior to approval as an official MVI station:

a. the prospective MVI station must project an image of a clean and orderly place of business.

b. MVI station locations must comply with local occupational, zoning and building inspection codes.

c. must have a covered vehicle stall or bay, with a roof and two walls, large enough to accommodate the inspection of a full sized motor vehicle.

D. - D.1. ...

E. Equipment Required for Safety Inspections

1. The following required equipment will be readily accessible during inspection hours:

a. - g. ...

h. a telephone number listed under the name of the station as it appears on the station license, with a telephone located at the place of business. All stations in the non-attainment area shall have the ability to access a telephone and the world wide web simultaneously during normal hours of operation.

i. on board diagnostic systems test equipment and evaporative system test equipment which includes gas cap pressure test equipment as per the United States Environmental Protection Agency (US EPA) specifications. Stations must have approved equipment readily accessible and in good working order. This equipment must be in or near the inspection area. The provisions of this Subparagraph shall only apply to inspection stations located in the non-attainment area. Any inspection station incorporated into a new DEQ Emissions Control Program non-attainment area shall adhere to US EPA specifications.

j. mechanic's creeper. The provisions of Subparagraph j of this Paragraph shall only apply to commercial motor vehicle inspection stations;

k. soapstone marker. The provisions of Subparagraph j of this Paragraph shall only apply to commercial motor vehicle inspection stations;

l. floor jack or lift or two jack stands. This equipment must be capable of lifting and safely holding up the vehicle being inspected. The provisions of Subparagraph j of this Paragraph shall only apply to school bus inspection stations;

m. additional equipment may be required by the department as it may be deemed necessary, for the proper operation of an inspection station. The department shall give prior written notice of any additional equipment requirements. After such written notice is given, such additional equipment requirement shall be enforced as if included in these rules.

F. Responsibility of Station Owner or Operator Waiting on Response. Upon application for designation as an official MVI station, the owner/operator has pledged himself to:

1. act as directed by the department when inspecting vehicles in accordance with these rules.

2. maintain a current, updated Official Rules and Regulations on the premises at all times. The manual will be

maintained in good condition and be readily available to the mechanic inspector. Any changes in Official Rules and Regulations received by the station operator must be placed immediately in the station's Official Rules and Regulations Manual. It is the owner/operator's responsibility to ensure all of his employees involved in the inspection program are aware of any changes;

3. use only employees authorized by the department to perform the actual inspection of motor vehicles;

4. - 6. ...

7. refrain from the use of alcohol or drugs while on duty; MVI stations shall not sell alcoholic beverages.

8. keep an adequate supply of both inspection and rejection certificates and all necessary forms on hand at all times; adequate supply shall be considered 15 certificates or more.

9. perform inspections and affix certificates of inspection only at the business location designated on the station license, affix valid certificates of inspection only to those vehicles which have been properly inspected and have passed the safety requirements

10. have at least one approved mechanic inspector on duty to make inspections during the hours of business each normal working day

11. be open for inspections at all times each day during normal business hours and to perform inspections throughout the year. Inspections shall be conducted a minimum of 40 hours per week; If a station has to close for more than one business day, that station must notify the department before closing.

12. - 13. ...

14. immediately follow all directives and instructions issued by the department; and

15. ...

G. Requirements for Approval of Mechanic Inspectors. Before any mechanic can perform inspections, the department shall review the mechanic's qualifications and may authorize him to inspect. The following requirements shall be met by each applicant prior to being approved as a mechanic inspector:

1. - 3. ...

4. shall possess a valid Louisiana operator's license. The operator's license shall not be subject to any order of suspension, revocation or cancellation or any other order or action which prevents the issuance of a duplicate or renewed operator's license. An approved mechanic inspector residing in a bordering state or those on active military duty shall furnish a valid operator's license from their resident state along with a copy of their driving record. The suspension, revocation, or cancellation of a mechanic inspector's operator's license shall be grounds to suspend his authority to inspect vehicles. A mechanic inspector shall notify the department immediately of such suspension, revocation, or cancellation of his operator's license;

5. shall successfully complete a training program conducted by an authorized representative of the department before being licensed to inspect vehicles. This training shall include all aspects of the Motor Vehicle Inspection program. Mechanic inspectors employed by stations approved to inspect school buses and commercial vehicles shall also be properly trained in those areas prior to being licensed. Mechanic inspectors who wish to be employed by a station

within the five parish nonattainment area must attend special training and cannot transfer from a station outside this area without first successfully passing said training;

6. - 7. ...

H. Duties and Responsibilities of Authorized Mechanic Inspectors

1. The authorized mechanic inspector shall:

a. - h. ...

i. abide by the inspection laws, rules, regulations and/or procedures. Failure to do so by an authorized mechanic inspector may result in a civil penalty being imposed and could result in the permanent revocation of inspection privileges and may subject him/her to criminal and or civil prosecution;

j. when changing employment from one inspection station to another, the mechanic inspector shall return the old mechanic inspector license and be re-certified at the new place of employment by the department before performing any inspections at the new location. Failure to obtain certification at the new location may result in revocation of the inspector's license; and

H.1.k. - I.2. ...

3. When all conditions have been met, the station license will be mailed or delivered to the station by a representative of the department appointed to supervise the station. The station license will be presented to any law enforcement officer upon demand.

AUTHORITY NOTE: Promulgated in accordance with R.S. 32:1304-1310.

HISTORICAL NOTE: Promulgated by the Department of Public Safety and Corrections, Office of State Police, Safety Enforcement Section, LR 25:2422 (December 1999), amended LR 27:2260 (December 2001), repromulgated LR 28:344 (February 2002), amended LR 38:2550 (October 2012).

§807. Operation as an Official Motor Vehicle Inspection Station

A. Change of Name, Location and/or Ownership

1. Persons operating under a motor vehicle inspection station license contemplating a change of name, location and/or ownership must notify the department before a change is made. All changes must be approved by the department prior to being made by the station.

2. Before a change can be made, the former motor vehicle inspection station license and all mechanic license(s) must be returned to the department. New station and mechanic applications, along with the appropriate fees and a new bond, must be submitted to reflect the change. The department will issue a new motor vehicle inspection station license and mechanic license(s). On the effective date of the change, all inspections will cease under the former motor vehicle inspection station license.

3. ...

B. Going Out of Business or Discontinuance of Inspections

1. Prior to going out of business or discontinuing inspections, a motor vehicle inspection station owner/operator must immediately notify the department. Either occurrence shall result in the cancellation of the motor vehicle inspection station license. All unused inspection and rejection certificates, along with the motor vehicle inspection station license and all mechanic licenses, must be returned to the department.

C. - C.2. ...

D. Periods of Inspection

1 - 1.a. ...

b. The fee for inspection of a passenger car or light truck and all other vehicles shall be \$10 for each year, except in non-attainment parishes. Gasoline powered passenger cars and light trucks under 10,001 pounds registered in non-attainment parishes and municipalities shall be assessed an \$18.00 inspection fee.

1.c. - 6. ...

E. R.S. 32:1306(G) Place of Inspection

1. Inspection stations need not reserve a bay or stall exclusively for inspections. However, a station shall give priority to customers seeking motor vehicle inspections. This should take no longer than 20 minutes.

2. Inspection and rejection certificates shall be issued to a vehicle only by an authorized, licensed mechanic inspector within an area approved by the department and at the authorized inspection station.

F. Ordering Inspection/Rejection Certificates

1. All orders for inspection or rejection certificates should be directed to the local Office of Motor Vehicles.

2. - 3. ...

4. Only authorized commercial Motor Vehicle Inspection stations with a current license will be permitted to purchase commercial inspection certificates. Each inspection station shall have only one person designated to purchase inspection certificates from the Office of Motor Vehicles. Only commercial inspection stations will be allowed to purchase commercial stickers.

5. ...

G. Lost or Stolen Inspection/Rejection Certificates

1. ...

2. Each inspection station will be accountable for each inspection and rejection certificate it receives from the department. Lost or stolen certificates must be accounted for on the log report by numerical listing. In lieu of the inspection information, the word "lost" or "stolen" must be noted on the log report by that certificate number.

3. Should an inspection or rejection certificate be lost or stolen, the department must be notified immediately. If a theft is suspected, the local law enforcement agency shall be asked to investigate the theft and forward a copy of the police report to the department.

4. ...

H. Warning Notices. A written warning may be issued by a representative of the department for any infraction of the rules and regulations. This will become a permanent part of the station's file and will be a basis for determining the issuance of a civil penalty or revocation. A copy shall be given to the mechanic inspector and/or the station owner at the time of issuance.

I. Motor Vehicle Inspection Log Report

1 - 3. ...

4. Dealer, fleet, public, and government Motor Vehicle Inspection stations will no longer be required to submit log reports to the department.

5. Log reports shall be kept in the log book at the Motor Vehicle Inspection station for 14 months. These reports shall be available for inspection by department personnel or law enforcement officers.

6. Stations in the non-attainment area which are required to submit their inspection information electronically

must do so in real time as set forth in the Code of Federal Regulations, 40CFR 51.358(2).

7. Authorized commercial Motor Vehicle Inspection stations are also required to follow the above regulations.

AUTHORITY NOTE: Promulgated in accordance with R.S. 32:1304-1310.

HISTORICAL NOTE: Promulgated by the Department of Public Safety and Corrections, Office of State Police, Safety Enforcement Section, LR 25:2424 (December 1999), amended 27:2260 (December 2001), repromulgated LR 28:345 (February 2002), amended LR 30:2859 (December 2004), LR 38:2552 (October 2012).

§808. Out-of-State Inspection Stations

Repealed.

AUTHORITY NOTE: Promulgated in accordance with R.S. 32:1301 et seq.

HISTORICAL NOTE: Promulgated by the Department of Public Safety and Corrections, Office of State Police, Safety Enforcement Section, LR 23:1701 (December 1997), amended LR 24:477 (March 1998), repealed LR 38:2553 (October 2012).

§809. General Inspection Requirements

A. Fees for Inspection

1. The fee for safety and commercial inspections will be the current fee set by law for each inspection performed, whether it was approved or rejected. Headlamp adjustments are included in this charge. No sales tax or late penalty fees will be collected on inspections

2. A rejected vehicle is entitled to one free re-inspection if returned to the same inspection station within the allowed period of time.

B. Repairs or Adjustments

1. Headlamp adjustments are included in the inspection of a vehicle as stated in R.S. 32:1306(C)(2). No other repairs or adjustments should be made without authorization by the owner or operator of the vehicle. Any unauthorized repairs or adjustments may result in a civil penalty or criminal charges being imposed and/or the revocation of the station's license and/or mechanic inspector's license.

2. ...

C. Issuance of Inspection Certificates

1. - 5.

6. Pre-inspections cause hardship for both you and the customer and will not be allowed.

7. Use of the stamp kit in place of certificate inserts is prohibited unless authorized by the department. Marking pens are not to be used in place of an insert.

D. Issuance of Rejection Certificates

1. - 6. ...

7. Should the owner or operator of a rejected vehicle refuse to accept the rejection certificate, it will be noted as such on the log report. The completed rejection certificate will be attached to the log report and sent to the department office at the end of the inspection week as required.

8. - 11. ...

E. Issuance of Restricted Rejection Certificates

1. - 2.f. ...

AUTHORITY NOTE: Promulgated in accordance with R.S. 32:1304-1310.

HISTORICAL NOTE: Promulgated by the Department of Public Safety and Corrections, Office of State Police, Safety Enforcement Section, LR 25:2426 (December 1999), amended LR 38:2553 (October 2012).

§811. Inspection Procedures

A. - B. ...

1. Certificate of registration contains information which must be verified with the corresponding information on the vehicle. A photocopy or original registration is acceptable. In lieu of a registration certificate, a vehicle may be inspected with a valid temporary license plate. The valid temporary registration is normally taped to the back of the temporary license plate.

B.2. - G. ...

H. The vehicle registration must indicate an address other than in Kenner, Westwego or New Orleans. Residents of these areas are required to comply with the municipal ordinances of periodic inspections of the area in which they reside.

Exception: In hardship cases approved by the department, vehicles from these areas with an expired inspection certificate may be inspected at state inspection stations which will be valid until the return of the vehicle to these municipal areas.

I. ...

AUTHORITY NOTE: Promulgated in accordance with R.S. 32:1304-1310.

HISTORICAL NOTE: Promulgated by the Department of Public Safety and Corrections, Office of State Police, Safety Enforcement Section, LR 25:2427 (December 1999), amended LR 38:2553 (October 2012).

§813. Required Equipment

A. Inspected items must be in proper condition and adjustment such that the item does not pose an unsafe condition as to endanger any person or property.

B. Speedometer/Odometer

1. The speedometer and odometer must be operational.

2. - 4. ...

C. Horn

1. - 3. ...

4. An auxiliary horn must be wired to a separate switch.

D. Brakes

1. Every vehicle required to be equipped with brakes must be tested. The mechanic inspector shall take physical control of the vehicle presented for inspection to determine if the brakes are operating correctly.

2. The test for stopping distance shall be made on a substantially level, dry, smooth, hard surface that is free from loose material. The vehicle shall not pull to the right or the left causing the vehicle to excessively alter its direction of travel.

3. A platform brake tester may be used instead of performing the road test. Before attempting to inspect a vehicle's brakes with a platform brake tester, the mechanic inspector shall be trained on and have experience in the use of the machine. The machine shall have adequate capacity and shall be calibrated and certified yearly. The mechanic inspector shall follow all tester manufacturers' directions.

4. Classifications for Brake Application

a. Single unit vehicles with a manufacturer's gross vehicle weight rating of less than 10,000 pounds shall have a braking distance of 30 feet.

b. Motorcycles and motor-driven cycles shall have a braking distance of 30 feet.

c. Single unit vehicles with a manufacturer's gross weight rating of 10,000 pounds or more shall have a braking distance of 40 feet.

d. Combination of a two-axle towing vehicle and a trailer with a gross trailer weight of 3,000 pounds or less shall have a braking distance of 40 feet.

e. Buses, regardless of the number of axles, not having a manufacturer's gross weight rating shall have a braking distance of 40 feet.

f. All combinations of vehicles in drive away, tow-away operations shall have a braking distance of 40 feet.

g. All other vehicles and combinations with a GVWR of 10,000 or more pounds shall have a braking distance of 50 feet.

E. Brake Requirement

1. - 2. ...

a. Every motor vehicle, other than motorcycles or motor driven cycles, shall be equipped with brakes adequate to control movement of and to stop and hold movement of such vehicle. Two separate means of applying brakes are required, each of which shall effectively apply brakes to at least two wheels.

b. Every motorcycle and every motor driven cycle manufactured with two wheels shall be required to be equipped with brakes on both wheels.

c. Every trailer or semi-trailer exceeding 3,000 pounds gross weight shall be equipped with brakes adequate to control the movement of and to stop and hold such vehicle.

3. The following exceptions exist.

a. Trailers and semi-trailers manufactured or assembled prior to January 1, 1963, need only be equipped with brakes on a single axle provided the combination of vehicles, consisting of the towing vehicle and its total load, is capable of complying with the performance requirements.

b. Farm trailers and semi-trailers manufactured or assembled prior to January 1, 1973, need not be equipped with brakes. Every farm trailer and farm semi-trailer manufactured or assembled on or after January 1, 1973, and having a gross weight exceeding 3,000 pounds shall be equipped with brakes in accordance with the requirements set forth above.

c. Vehicles carrying forest products in their natural state shall not be required to have a brake on the drag axle if the wheels of the drag axle touch the ground only when the vehicle is loaded. However, this provision does not apply to trailers or trucks with more than two axles.

F. Parking Brakes

1. ...

G. Lighting System

1. - 6. ...

7. All motor vehicles, except motorcycles, motor scooters and motor bikes shall be equipped with at least two operable headlamps, emitting white light only. These headlamps may be the multiple beam type or the single beam type. The type headlamp with which the vehicle is equipped will determine what requirements must be met.

8. Motor vehicles must have at least two headlamps, but not more than four headlamps, half mounted on each side on the front of the vehicle.

9. The mounted height of headlamps, measured from the center of the lamp to the level ground, will not be more than 54 inches nor less than 24 inches.

10. All vehicles must be equipped with an operable dimmer switch and beam indicator (high or low beam designation).

11. Headlamp concealment devices must remain fully open when the headlamp is illuminated. The concealment device must be opened automatically or manually without the use of any tools.

12. Aiming of headlamps is as follows.

a. The inspection shall include the adjustment of headlights when needed and if mechanically practical. This service shall be performed at no additional cost to the operator of the motor vehicle.

b. Headlights shall be aimed using only approved equipment and following manufacturer's recommendations.

H. Parking Lamps on the front of the vehicle. When actuated, the front parking lamps must display either white or amber light. These lamps must operate as originally equipped.

I. Turn Indicator Lamps, Front and Rear

1. Any vehicle manufactured or assembled after December 31, 1962, must be equipped with lamps which indicate the direction of a turn displaying the signal to both the front and rear of the vehicle.

2. Front Turn Indicator Lamps. Both front turn indicator lamps must be mounted on the same level and display an amber light, except those vehicles manufactured or assembled prior to January 1, 1969. Those vehicles may emit either a white or amber colored light.

3. Rear Turn Indicator Lamps. Both rear turn indicator lamps must be mounted on the same level with one on each side of the vehicle. The lamps may emit either red or amber color light only. The lens covering the lamp may not be cracked, broken or missing causing white light to be emitted to the rear of the vehicle. The lens must be of an original type lens.

4. The signal cancellation must operate as originally equipped and cancel the signal when the turning maneuver is completed, except for truck-tractors, motorcycles or motor driven cycles.

J. Tail Lamps

1. Tail lamps must be covered with an original type lens. It cannot be cracked, broken or missing any of the lens which would emit white light to the rear of the vehicle.

2. Vehicles manufactured or assembled after December 31, 1962, must be equipped with two tail lamps.

3. The tail lamp must emit red light only.

4. The maximum height of tail lights is 72 inches and the minimum height allowed is 15 inches.

K. Stop Lamps

1. Vehicles manufactured or assembled after December 31, 1962, are required to have two operational stop lamps with the exception of motorcycles, motor driven cycles or truck tractors, which must have at least one.

2. The stop lamps must emit red light only visible at least 300 feet to the rear of the vehicle.

3. The stop lamps must operate as originally equipped.

4. The lens covering the stop lamp must be of an original type not broken, cracked or missing any portion which allows white light to be emitted to the rear of the vehicle.

L. High Mount Brake Lamp

1. All passenger vehicles manufactured September 1, 1985, and thereafter must be equipped with a third stop lamp. This lamp is to be mounted in the line of sight near the rear window with at least 4 1/2 inches of exposed red area on the lens. Light duty trucks with the model year 1995 and later are required to have high mount lamps.

2. The high mount brake lamp must be present and operate as originally equipped.

3. The vehicle shall be rejected if the high mount brake lamp is obscured by any add on item such as ladder racks, luggage racks, etc. Light duty trucks that are equipped with high mount brake lamps and have had a camper top installed must have a similar high mount brake lamp installed on the camper top in a corresponding position in the rear. If the vehicle comes equipped with a high mount brake lamp, it cannot be obscured by any after market item unless it is replaced with a comparable lamp as originally equipped and visible from the rear of the vehicle.

M. Back-Up Lamps

1. Vehicles manufactured or assembled after January 1, 1969, must be equipped with no more than two back-up lamps.

2. The back-up lamp must emit a white light only.

3. The back-up lamps must be lighted only when the vehicle is in reverse gear and must not light when the vehicle is in any other gear.

N. License Plate Lamp

1. The license plate lamp must illuminate the license plate making it visible for 50 feet to the rear.

2. The lamp is to be lighted with white light only when headlamps or auxiliary driving lamps are lighted. Except for antique vehicles, the use of neon lights or the use of any other lights which obscure the license plate is prohibited.

O. Outside/Inside Rearview Mirrors

1. From the driver's seated position, visually inspect the left outside rearview mirror and the interior mirror for clear and reasonably unobstructed view 200 feet to the rear.

2. The mirrors should not be cracked, pitted or clouded to the extent that the driver's vision would be obscured. Inspect mirrors for correct location and stable mounting.

3. Mirrors must maintain set adjustment so that the rear vision is not impaired.

4. All vehicles manufactured after December 31, 1972, must be equipped at the factory with a left-hand, outside rearview mirror. This includes motorcycles and motor driven cycles. If two outside mirrors are utilized, no inside mirror is required.

P. Windshield Wipers

1. All vehicles manufactured after December 31, 1972, must be equipped with a wiper system capable of operating at two or more speeds. Two wipers are required if the vehicle was originally equipped with such. All motor vehicles equipped with windshields, except motorcycles and motor driven cycles, are required to have windshield wipers.

2. Windshield wipers must operate as originally equipped to operate. If vacuum operated, the engine must be idling and the control must be turned on to the maximum setting.

3. Windshield wipers shall not smear or severely streak the windshield.

4. Proper contact of the blades with the windshield is required. Inspect by raising the arm away from the windshield and then release it. The arm should return to the original position or should urge the wiper blade to contact the windshield firmly.

5. The condition of the blades and metal parts must be checked.

6. Metal parts and blades shall not be missing or damaged. Blades shall not show signs of physical breakdown of rubber wiping element. Rubber blades shall not be damaged, torn or hardened to the point that they do not clear the windshield.

7. The windshield wiper control shall be within reach of the driver.

Q. Windshield Washers

1. All vehicles manufactured after 1985 are required to have operating windshield washers.

R. Windshields

1. Every passenger vehicle, other than a motorcycle, shall be equipped with an adequate windshield.

2. For inspection purposes, the windshield is composed of three areas as follows.

a. Acute Area. The acute area is directly in the driver's line of vision in the center of the driver's critical area. It is 8 1/2" x 11", the size of a standard piece of paper. In this area no cracks are allowed. No more than two stars, nicks, chips, bulls eyes or half moons in excess of 1/2 inch will be allowed.

b. Critical Area. The critical area is the area other than the acute area which is cleaned by the normal sweep of the windshield wiper blades on the driver's side only. In this area, any star larger than 2 inches in diameter; two or more stars larger than 1 1/2 inches in diameter and two or more cracks which extend more than 8 inches in length will not be allowed.

c. Non-Critical Area. This area consists of all other windshield area other than the acute or critical area.

3. A windshield can be rejected at any time the condition creates a safety hazard. If a windshield is cracked in such a way as to jeopardize the integrity of the windshield, the vehicle is to be rejected.

S. Windows and Glass Sun screening and Glass Coating

1. Windshields are allowed to have sunscreen extend down from the topmost portion of the windshield no more than 5 inches. The sunscreen shall be transparent and not red or amber in color. This 5 inch limitation also applies to vehicles with a sun screen certificate.

2. Vehicles being presented for inspection that do not have a sunscreen certificate shall be inspected as follows.

a. Windshield. As stated above, sunscreen may not extend more than 5 inches from the top of the windshield and may not be red or amber in color.

b. Front side windows must have at least 40 percent light transmission.

c. Side windows behind driver must have at least 25 percent light transmission.

d. Rearmost glass must have at least 12 percent light transmission.

e. Label. There must be a label affixed to the lower right corner of the driver's side window. It must not exceed 1 1/2 inches square in size. It must be installed between the glass and the sunscreen material and must contain the name and city of the installer.

3. Light transmission will be checked using only an approved tint meter and following manufacturer's directions.

4. Sunscreen shall not have a luminous reflectance of more than 20 percent.

5. No tint material may be affixed to the front windshield or the front side windows if the material alters the color of the light transmission. No tint other than smoke shall be allowed.

6. Exceptions to the Sunscreen Rule

a. Sunscreen regulations do not apply to windows behind the driver of trucks, buses, trailers, motor homes, multi-purpose passenger vehicles and all windows of vehicles used for law enforcement purposes.

b. Vehicles with sunscreen certificates as stated above.

c. A person with a medical condition which makes that individual sensitive to sun exposure may obtain a waiver form provided by the department. The waiver must be completed by a licensed physician and must be signed by a department officer. This waiver exempts the vehicle identified on the form from all restrictions except windshields as provided in R.S. 32:361.1.

d. The medical exemption affidavit shall:

i. be valid for a period of not more than 3 years, except for the following provisions;

ii. be valid only for vehicles registered in this state where the registered owner, spouse or immediate family member has an approved affidavit that shall be kept in the motor vehicle at all times;

iii. not be applied for, or issued to, persons convicted of crimes of violence as defined in RS 14:1 (13) or criminal offenses involving controlled dangerous substances as defined in RS 40:961 et seq.

iv. be returned to applicant by an officer, if approved;

v. be non-transferable.

vi. be valid for the duration of ownership of a vehicle whose owner is age 60 years or older.

(a). The registered owner of the vehicle is 60 years and older at the time of application for a Medical Exemption Affidavit, or the individual becomes 60 years old while in possession of a valid Medical Exemption Affidavit, then the affidavit will be valid for the duration of that individual's ownership of the vehicle as provided in RS 32:361.2(A)(3)(c) unless deemed otherwise by the department.

e. The following non-exclusive list of persons, or entities, shall be eligible for a security exemption from the provisions of R.S. 32:361.1:

- i. private investigators;
- ii. bail enforcement agents;
- iii. railroad police officers;

iv. Louisiana peace officers, P.O.S.T. certified and sworn;

v. elected or appointed public officials;

f. Security Exemption Criteria

i. Vehicle must be:

(a). properly licensed, insured and registered, all in Louisiana; and

(b). owned or leased by an applicant

g. Security Exemption Affidavit

i. An individual seeking exemption to window tint restrictions can obtain a security exemption affidavit form at the Department Headquarters, any Motor Vehicle field office or via the World Wide Web by accessing www.LSP.org.

ii. The security exemption affidavit must be complete, sworn and subscribed in the presence of a Notary Public. The security exemption affidavit must include:

(a). applicant's name

(b). address, city, state and zip code;

(c). vehicle description (year, make, model);

(d). vehicle identification number (VIN);

(e). vehicle license plate number;

(f). need, reason or explanation for exemption;

and

(g). signature of applicant

h. Security Exemption Process

i. A completed Security Exemption Affidavit must be mailed to the Department Headquarters Office, P.O. Box 66614, Mail Slip 26, Baton Rouge, LA 70896-6614. Security Exemption Affidavits will be reviewed and subsequently approved or disapproved by the department.

ii. Approved Security Exemption Affidavits will be returned to applicant.

iii. An applicant whose Security Exemption Affidavit is disapproved will receive written notification of that decision by U.S. Mail. The correspondence will outline the reason(s) for denial. An applicant may write a letter of rebuttal germane to the reason(s) for denial. Letters of rebuttal will be taken under advisement. Once a final determination of eligibility has been made, an applicant has no further recourse. The Department of Public Safety and Corrections may approve, disapprove, cancel or revoke exemptions for window tint restrictions as deemed appropriate.

T. Body and Sheet Metal. Exterior components of the body and sheet metal parts must not be damaged and/or dislocated so that they project from the vehicle and present a safety hazard to occupants, pedestrians or other vehicles.

U. Fenders

1. Fenders, covers or devices including splash aprons and mud flaps shall be required unless the body of the vehicle or attachments afford protection to effectively minimize the spray or splash of water, mud or loose material on the highway from the rear of the vehicle.

2. Tires shall not extend beyond fenders or attachments more than 1 inch to provide a safe condition.

3. All vehicles with an unladen weight of under 1,500 pounds and trucks or farm vehicles handling or hauling agricultural or forestry products are exempt from fender requirements.

4. Front and rear fenders that have been removed because of being hazardous or unserviceable must be

replaced. If replacement of the front or rear fender removes a required lighting device, the lighting device must be re-installed or replaced.

V. Bumpers

1. Bumpers removed from vehicles originally equipped with bumpers will not be permitted. However, rear bumpers are not required on pickup trucks.

2. Rebuilt or modified bumpers must be made of material equivalent to the original bumpers and must be equal in strength.

3. Bumpers must be securely attached and not broken or protruding.

W. Doors. The vehicle's doors will be inspected as follows.

1. All doors must be present and operational with factory installed handles.

2. Doors must be secured in the closed position.

3. Doors must function as originally equipped by the factory.

X. Hood Latch. The hood must be securely held in a closed position by an original type latch.

Y. Floor Pan. No holes or rusted areas are permitted in the occupant compartment or trunk. Inspectors may require that the trunk of a vehicle be opened on vehicles possessing serious body rust throughout.

Z. Wheels and Tires

1. Conduct a visual check of the wheels and tires to detect any condition that would create a hazard or an unsafe condition.

2. All tires must be for highway use. Tires marked "Not for Highway Use", "Farm Use Only" or "For Racing Purposes Only" are not allowed.

3. Tires without tread wear indicators shall have 2/32 inch tread remaining when measured in any two adjacent major grooves at a minimum of three locations spaced approximately equal distance around the major tire groove.

4. Tires with tread wear indicators shall not allow the indicators to contact the road in any two adjacent major grooves at three locations spaced equally around the tire.

5. Cord shall not be exposed through the tread. Tread cuts, snags or sidewall cracks in excess of 1 inch in any direction deep enough to expose cords, are not allowed.

6. Tires shall not have visible bumps, bulges or knots indicating partial failure or separation of the tire structure.

7. Tires shall not be re-grooved or re-cut below the original groove depth except tires which have undertread rubber for this purpose and are identified as such.

8. Tires on the same axle shall be of the same type construction.

9. Wheels shall not be bent, loose, cracked or damaged as to affect safe operation.

10. Rims or wheel flanges shall not be defective.

11. Wheels should be secure. Only one missing or defective bolt, nut or lug is allowed except on a four-hole pattern wheel. On a four hole pattern wheel no missing or defective lugs are allowed.

AA. Steering Mechanism

1. An original equipment type steering wheel is required.

a. The steering wheel shall be of the same diameter as originally equipped. Any modification that may affect the proper steering of the vehicle is prohibited.

b. Chain-type steering wheels shall not be allowed.

2. Excessive play, tightness, binding or jamming shall not be allowed.

a. With the front wheels in a straight ahead position, check steering for free play. More than 2 inches of free play for power assisted steering and more than 3 inches of free play for manual steering will not be permitted.

3. Excessively worn or broken parts in the steering components, any leakage of the power unit or excessive looseness of the power system fan belt shall not be permitted.

4. Modification of the front end and steering mechanism in any manner shall not be permitted.

BB. Suspension and Shock Absorbers

1. The vehicle must have operational shock absorbers and springs.

2. The vehicle must have at least 3 inches of suspension travel.

3. The vehicle must have at least 4 inches of ground clearance measured from the frame with the vehicle on a level surface.

CC. Seats and Seat Belts

1. Front seats shall be securely anchored to the floor pan. Missing anchor bolts are not permitted. The seat adjusting mechanism shall not slip out of the set position.

2. Seat belts shall operate and adjust as originally intended. Seat belt buckles shall operate properly.

3. Webbing shall not be split, frayed or torn.

4. Seat belts shall be securely mounted. Anchorages shall be secure.

5. Passenger cars, vans or trucks with a gross weight of 6,000 pounds or less, and manufactured after January 1, 1981, require front seat belts only.

DD. Exhaust System. The exhaust system includes the piping leading from the flange of the exhaust manifold to, and including, the mufflers, resonators, tail piping and emission control device. Visually inspect the exhaust system for rusted or corroded surfaces.

1. The vehicle must have a muffler.

2. No loose or leaking joints in the exhaust system are allowed. Also, no holes, leaking seams, loose interior baffles or patches on the muffler are allowed.

3. The tail pipe end cannot be pinched.

4. Elements of the system must be fastened securely, including missing connections or missing or broken hangers.

5. A muffler cannot have a cut-out bypass, or similar device which allows fumes to escape.

6. The muffler cannot emit excessive smoke, fumes, or noise.

7. The tail pipe shall extend past the passenger compartment.

AUTHORITY NOTE: Promulgated in accordance with R.S. 32:1304-1310.

HISTORICAL NOTE: Promulgated by the Department of Public Safety and Corrections, Office of State Police, Safety Enforcement Section, LR 25:2428 (December 1999), amended LR 28:345 (February 2002), amended LR 38:2553 (October 2012).

Subchapter C. Vehicle Emission Inspection and Maintenance Program

Subchapter D. Inspection Procedures for School Buses

§821. General Information

A. - D. ...

1. The station must have an area large enough to accommodate a bus. The inspection area will be subject to approval by the department.

2. ...

AUTHORITY NOTE: Promulgated in accordance with R.S. 32:1304-1310.

HISTORICAL NOTE: Promulgated by the Department of Public Safety and Corrections, Office of State Police, Safety Enforcement Section, LR 25:2434 (December 1999), LR 38:2557 (October 2012).

Subchapter E. Federal Motor Carrier Safety Regulations
§827. Code of Federal Regulations (C.F.R.) §390.15
Motor Carrier Safety Regulations

A. - D.2. ...

a. The second copy shall be kept in the commercial log book at the station for 14 months. If a station inspects no vehicles during a given week/month, one report shall be submitted as previously described, with the word none written across the face of the report.

3. - 4. ...

AUTHORITY NOTE: Promulgated in accordance with R.S. 32:1304-1310.

HISTORICAL NOTE: Promulgated by the Department of Public Safety and Corrections, Office of State Police, Safety Enforcement Section, LR 25:2437 (December 1999), amended LR 38:2558 (October 2012).

§829. Minimum Periodic Inspection Standards

A. The mechanic inspector shall record the expired sticker number on the log report and then remove the expired sticker prior to continuing with the inspection.

1. The mechanic inspector shall conduct a review of the documents for the vehicle ensuring that all documents are in agreement.

2. Certificate of Registration. This contains information which must be verified with the corresponding information on the vehicle. A photocopy or original registration is acceptable. In lieu of a registration certificate, a vehicle may be inspected with a valid temporary license plate.

B. Vehicle Identification Number (VIN). The VIN must agree with Certificate of Registration and the insurance document. It must match the VIN displayed on the vehicle.

C. License Plate. The registration indicates a license plate number and expiration date of the plate. This information must correspond with the information displayed on the vehicle. The license plate must be valid.

1. A temporary registration authorization indicating an apportioned plate has been applied for is also acceptable in lieu of a registration. When this condition exists, no license plate is present. The temporary registration allows the vehicle to be used until the apportioned plate and cab card are issued.

D. Operator License. Must be valid and in the immediate possession of the vehicle operator. It must be presented to the mechanic inspector, and the license number must be taken from the driver's license and recorded in the appropriate block on the log report.

1. A valid out-of-state driver's license is acceptable. The state in which it was issued must be noted on the log report.

2. A temporary driving permit issued in connection with a traffic violation when the operator's license is held

may be accepted until the permit expires on the court date noted.

E. Proof of current liability insurance must be shown to the mechanic inspector.

1. A current certificate of insurance, motor vehicle liability insurance policy (or duplicate of the original) or a binder for the same is acceptable. A vehicle's policy identification card or photocopy of the same may also be accepted. These documents shall designate the name of the insurance company affording coverage, the policy number, the effective dates of coverage (both the beginning and ending dates are required) and a description of the vehicle covered including the VIN. A binder must be an official accord binder form and can be handwritten.

2. A copy of a motor vehicle liability bond. This document may or may not describe the vehicle covered.

3. A certificate from the state treasurer indicating a deposit was made to the state. It will not have a description of the vehicle, but the vehicle must be registered under the same name as noted on the certificate.

4. A certificate of self-insurance issued by the Louisiana Department of Public Safety and Corrections. It is not required to describe the vehicle covered.

F. License Plate Mounting and Condition: In addition to being valid, the license plate will be inspected for the following:

1. must be secured to the mounting brackets;

2. must be clean, clearly visible and readable for a distance of 50 feet to the rear of the vehicle. Plates shall not be obscured or damaged so that the numbers cannot be identified;

3. must be mounted in the rear;

4. truck-trailer, emergency firefighting equipment, dump-body trucks, trucks over 6,000 pounds and forestry product licensed vehicles may display the plate on either the front or rear of the vehicle.

G. All vehicles presented for inspection will be inspected for all of the following items: vehicle registration, vehicle license plate, driver's license and proof of liability insurance.

H. Every motor vehicle, trailer, semi-trailer and pole trailer registered in this state shall bear a valid safety inspection certificate issued in the State of Louisiana

1. Commercial Motor Vehicles, truck tractors, trailers, and semi trailers in interstate commerce which are subject to the Federal Motor Carrier Safety Regulations shall be exempt from the inspection requirements if,

2. the truck/truck tractor is registered with an apportioned plate or the trailer and semi trailer is being pulled by a truck/truck tractor registered with an apportioned plate.

a. The vehicle must have an alternate means of compliance with the requirements of 49CFR. (See exemptions under 32:131(D))

1. As per minimum periodic inspection standards, a vehicle shall be issued a restricted rejection certificate if it has any one of the following defects or deficiencies.

J. Brake System

1. Service Brakes

a. Absence of braking action on any axle required to have brakes upon application of the service brakes (such as missing brakes or brakes shoe(s) failing to move upon application of a wedge, s-cam or disc brake).

b. Missing or broken mechanical components, including shoes, lining, pads, springs, anchor pins, spiders and cam shaft support brackets.

c. Audible air leak at brake chamber (ex. ruptured diaphragm, loose chamber clamp, etc.).

d. Readjustment Limits. The maximum stroke at which brakes should be readjusted is shown in the columns below. Any brake 1/4 inch or more past the readjustment limit or any two brakes less than 1/4 inch beyond the readjustment limit shall be cause for rejection. Stroke shall be measured with the engine off and reservoir pressure of 80 to 90 psi with brakes fully applied. Wedge Brake Data: Movement of the scribe mark on the lining shall not exceed 1/16 inch. Do not attempt to adjust automatic slack adjusters. The limits below are for manual slack adjusters only.

The Maximum Stroke at Which Brakes Should Be Readjusted			
Type	Effective Area (Square Inch)	Outside Diameter (Inches)	Maximum Stroke at Which Brakes Should Be Readjusted
Bolt Type Brakes Chamber Data			
A	12	6 15/16	1 3/8
B	24	9 3/16	1 3/4
C	16	8 1/16	1 3/4
D	6	5 1/4	1 1/4
E	9	6 3/16	1 3/8
F	36	11	2 1/4
G	30	9 7/8	2
Rotochamber Data			
9	9	4 9/32	1 1/2
12	12	4 13/16	1 1/2
16	16	5 13/32	2
20	20	5 15/16	2
24	24	6 13/32	2
30	30	7 1/16	2 1/4
36	36	7 5/8	2 3/4
50	50	8 7/8	3
Clamp Type Brake Chamber Data			
6	6	4 1/2	1 1/4
9	9	5 1/4	1 3/8
12	12	5 11/16	1 3/8
16	16	6 3/8	1 3/4
20	20	6 25/32	1 3/4
24	24	7 7/32	1 3/4
30	30	8 3/32	2
36	36	9	2 1/4

**2" for long stroke design

e. Brake Lining or Pads—

i. lining or pad is not firmly attached to the shoe;
 ii. saturated with oil, grease or brake fluid;
 iii. non-steering axles. Lining with a thickness less than 1/4 inch at the shoe center for air drum brakes, 1/16 inch or less at the shoe center for hydraulic and electric drum brakes, and less than 1/8 inch for air disc brakes;

iv. Steering brakes, lining with a thickness less than 1/4 inch at the shoe center from drum brakes, less than 1/8 inch for air disc brakes and 1/16 inch or less for hydraulic disc and electric brakes.

f. Missing Brakes on Axle Required to Have Brakes

g. Mismatch across any power unit steering axle of:
 i. air chamber size;
 ii. slack adjuster length.

2. Parking Brake System. No brakes on the vehicle or combination are applied upon actuation of the parking brake control, including drive line hand controlled parking brakes.

3. Brake Drums or Rotors—

a. with any external crack or cracks that open upon brake application (do not confuse short hairline heat check cracks with flexural cracks);

b. any portion of the drum or rotor missing or in danger of falling away.

4. Brake Hose—

a. hose with any damage extending through the outer reinforcement ply. (Rubber impregnated fabric cover is not a reinforcement ply.) (Thermoplastic nylon may have braid reinforcement or color difference between cover and inner tube. Exposure of second color is cause for rejection.);

b. bulge or swelling when air pressure is applied;

c. any audible leaks;

d. two hoses improperly joined (such as a splice made by slicing the hose ends over a piece of tubing and clamping the hose to the tube). (Exception: A splice utilizing a reverse claw connector is acceptable.);

e. air hose cracked, damaged by heat, broken or crimped.

5. Brake Tubing—

a. any audible leaks;

b. tubing cracked, damaged by heat, broken or crimped.

6. Low Pressure Warning Device. Missing, inoperative or does not operate at 55 psi and below, or one-half the governor cut-out pressure, whichever is less.

7. Tractor Protection Valve. Inoperative or missing tractor protection valve(s) on power unit.

8. Air Compressor—

a. compressor drive belts in condition of impending or probable failure;

b. loose compressor mounting bolts;

c. cracked, broken or loose pulley;

d. cracked or broken mounting brackets, braces or adapters.

9. Electric Brakes—

a. absence of braking action on any wheel required to have brakes;

b. missing or inoperative breakaway braking device.

10. Hydraulic Brakes (including power assist over hydraulic and engine drive hydraulic booster)—

a. master cylinder less than one-fourth full;

b. no pedal reserve with engine running except by pumping pedal;

c. power assist unit fails to operate;

d. seeping or swelling brake hose(s) under application of pressure;

e. missing or inoperative check valve;

f. has any visually observed leaking hydraulic fluid in the brake system;

g. has hydraulic hose(s) abraded (chafed) through outer cover to fabric layer;

h. fluid lines or connections leaking, restricted, crimped or broken;

i. brake failure or low fluid warning light on and/or inoperable.

11. Vacuum System—
 - a. has insufficient vacuum reserve to permit one full brake application after engine is shut off;
 - b. has vacuum hose(s) or line(s) restricted, abraded (chafed) through outer cover to cord ply, crimped, cracked, broken or has collapse of vacuum hose(s) when vacuum is applied;
 - c. lacks an operable low-vacuum warning device as required.

K. Coupling Devices

1. Fifth Wheels
 - a. Mounting to Frame—
 - i. any fasteners missing or ineffective;
 - ii. any movements between mounting components;
 - iii. any mounting angle iron cracked or broken.
 - b. Mounting plates and pivot brackets—
 - i. any fasteners missing or ineffective;
 - ii. any welds or parent metal cracked;
 - iii. more than 3/8 inch horizontal movement between pivot bracket pin and bracket.
 - iv. pivot bracket pin missing or not secured.
 - c. Sliders—
 - i. any latching fasteners missing or ineffective;
 - ii. any fore or aft stop missing or not securely attached;
 - iii. movement more than 3/8 inch between slider bracket and slider base;
 - iv. any slider component cracked in parent metal or weld;
 - d. Lower Coupler—
 - i. horizontal movement between the upper and lower fifth wheel halves exceeds 1/2 inch;
 - ii. operating handle not in closed or locked position;
 - iii. kingpin not properly engaged;
 - iv. separation between upper and lower coupler allowing light to show through from side to side;
 - v. crack in the fifth wheel plate. Exceptions: Cracks in the fifth wheel approach ramps and casting shrinkage cracks in the ribs of the body or a cast fifth wheel;
 - vi. locking mechanism parts missing, broken or deformed to the extent the kingpin is not securely held.

2. Pintle Hooks

- a. Mounting to Frame—
 - i. any missing or ineffective fasteners (a fastener is not considered missing if there is an empty hole in the device, but no corresponding hole in the frame or vice versa);
 - ii. mounting surface cracks extending from point of attachment (e.g., cracks in the frame at mount bolt holes);
 - iii. loose mounting;
 - iv. frame cross member providing pintle hook attachment cracked;
- b. Integrity—
 - i. cracks anywhere in pintle hook assembly;
 - ii. any welded repairs to the pintle hook;
 - iii. any part of the horn section reduced by more than 20 percent;
 - iv. latch insecure.

3. Drawbar/Towbar Eye

- a. Mounting—

- i. any cracks in attachment welds;
 - ii. any missing or ineffective fasteners.
- b. Integrity—
- i. any cracks;
 - ii. any part of the eye reduced by more than 20 percent.

4. Drawbar/Towbar Tongue

- a. Slider (Power or Manual)—
 - i. ineffective latching mechanism;
 - ii. missing or ineffective stop;
 - iii. movement of more than 1/4 inch between slider and housing;
 - iv. any leaking, air or hydraulic cylinders, hoses or chambers (other than slight oil weeping normal with hydraulic seals).
- b. Integrity—
 - i. any cracks;
 - ii. movement of 1/4 inch between subframe and drawbar at point of attachment.

5. Safety Devices—

- a. safety devices missing;
- b. unattached or incapable of secure attachment;
- c. chains and hooks:
 - i. worn to the extent of a measurable reduction in link cross section;
 - ii. improper repairs including welding, wire or small bolts, rope and tape.
- d. cable:
 - i. kinked or broken cable stands;
 - ii. improper clamps or clamping.

6. Saddle-Mounts

- a. Method of Attachment—
 - i. any missing or ineffective fasteners;
 - ii. loose mountings;
 - iii. any cracks or breaks in a stress or load bearing member;
 - iv. horizontal movement between upper and lower saddle-mount halves exceeds 1/4 inch.

L. Exhaust System—

1. any exhaust system determined to be leaking at a point forward of or directly below the driver/sleeper compartment;
2. a bus exhaust system leaking or discharging to the atmosphere:
 - a. gasoline powered—excess of 6 inches forward of the rearmost part of the bus;
 - b. other than gasoline powered—in excess of 15 inches forward of the rear most part of the bus;
 - c. other than gasoline powered—forward of the door or window designed to be opened. (Exception: Emergency exits);
3. no part of the exhaust system of any motor vehicle shall be so located as would be likely to result in burning, charring, damaging the electrical wiring, the fuel supply or any combustible part of the motor vehicle.

M. Fuel System—

1. a fuel system with a visible leak at any point;
2. a fuel tank filler cap missing;
3. a fuel tank not securely attached to the motor vehicle by reason of loose, broken or missing mounting bolts or brackets (some fuel tanks use springs or rubber bushing to permit movement).

N. Lighting Devices. All lighting devices and reflectors required by Section 393 shall be operable.

1. Headlight dimmer switch must work as originally equipped.

O. Safe Loading—

1. part(s) of the vehicle or condition of loading such that the spare tire or any part of the load or dunnage can fall onto the roadway;

2. protection against shifting cargo. Any vehicle without a front-end structure or equivalent device as required.

P. Steering Mechanism

1. Steering Wheel Free Play—

a. on vehicles equipped with power steering the engine must be running.

Steering Wheel Diameter	Manual Steering System	Power Steering System
16"	2"	4 1/2"
18"	2 1/4"	4 3/4"
20"	2 1/2"	5 1/4"
22"	2 3/4"	5 3/4"

2. Steering Column—

a. any absence or looseness of u-bolt(s) or positioning part(s);

b. worn, faulty or obviously repair welded universal joints;

c. steering wheel not properly secured.

3. Front Axle Beam and all Steering Components other than Steering Column—

a. any crack(s);

b. any obvious welded repair(s).

4. Steering Gear Box

a. Any mounting bolt(s) loose or missing;

b. any crack(s) in gear box or mounting brackets.

5. Pitman Arm. Any looseness of the pitman arm on the steering gear output shaft.

6. Power Steering—auxiliary power assist cylinder loose.

7. Ball and Socket Joints—

a. any movement under steering load of a stud nut;

b. any motion, other than rotational, between any linkage member and its attachment point of more than 1/4 inch.

8. Tie Rods and Drag Links—

a. loose clamp(s) or clamp bolt(s) on tie rods or drag links;

b. any looseness in any threaded joint.

9. Nuts—loose or missing on tie rods, pitman arm, drag link, steering arm or tie rod arm.

10. Steering System. Any modification or other condition that interferes with free movement of any steering component.

Q. Suspension—

1. any u-bolt(s), spring hanger(s) or other axle positioning part(s) cracked, broken, loose or missing resulting in shifting of an axle from its normal position (after a turn, lateral axle displacement is normal with some suspensions. Forward or rearward operation in a straight line will cause the axle to return to alignment).

2. Spring Assembly—

a. any leaves in a leaf spring assembly broken or missing;

b. any broken main leaf in a leaf spring assembly (includes assembly with more than one main spring);

c. coil spring broken;

d. rubber spring missing;

e. one or more leaves displaced in a manner that could result in contact with a tire, rim, brake drum or frame;

f. broken torsion bar spring in a torsion bar suspension;

g. deflated air suspension, i.e., system failure, leak, etc.

3. Torque, Radius, or Tracking Components—

a. Any part of a torque, radius or tracking component assembly or any part used for attaching the same to the vehicle frame or axle that is cracked, loose, broken or missing. (Does not apply to loose bushing in torque or track rods.)

R. Frame

1. Frame Member—

a. any cracked, broken loose or sagging frame member;

b. any loose or missing fasteners including fasteners attaching functional components such as engine, transmission, steering gear suspension, body parts and fifth wheel.

2. Tire and wheel clearance—any condition, including loading, that causes the body or frame to be in contact with a tire or any part of the wheel assembly.

3. Adjustable axle Assemblies—adjusting axle assembly with locking pins missing or not engaged.

S. Tires

1. Any tire on any steering axle of a power unit:

a. with less than 4/32-inch tread when measured at any point on a major tread groove;

b. has body ply or belt material exposed through the tread or sidewall;

c. has any tread or sidewall separation;

d. has a cut where the ply or belt material is exposed;

e. labeled "Not for Highway Use" or displaying other markings which would exclude use on steering axle;

f. a tube-type radial tire without radial tube stem markings. These markings include a red band around the tube stem or the word Radial embossed in metal stems, or the word Radial molded in rubber stems;

g. mixing bias and radial tires on the same axle;

h. tire flap protrudes through valve slot in rim and touches stem;

i. re-grooved tire except motor vehicles used solely in urban or suburban service [see exception in 49 CFR 393.76(E)];

j. boot, blowout patch or other ply repairs;

k. weight carried exceeds tire load limit. This includes overloaded tire resulting from low air pressure;

l. tire is flat or has noticeable (e.g., can be heard or felt) leak;

m. any bus equipped with recapped or retreaded tire(s);

n. so mounted or inflated that it comes in contact with any part of the vehicle.

2. All tires other than those found on the steering axle of a power unit:

a. weight carried exceeds tire load limit. This includes overloaded tire(s) resulting from low air pressure;

b. tire is flat or has noticeable (e.g., can be heard or felt) leak;

c. has body ply or belt material exposed through the tread or sidewall;

d. has any tread or sidewall separation;

e. has a cut where ply or belt material is exposed;

f. so mounted or inflated that it comes in contact with any part of the vehicle (this includes a tire that contacts its mate);

g. is marked "Not for Highway Use" or otherwise marked and having like meaning;

h. with less than 2/32-inch tread when measured at any point on a major tread groove.

T. Wheels and Rims

1. Lock or Side Ring. Bent, broken, cracked, improperly seated, sprung or mismatched ring(s).

2. Wheels and Rims. Cracked or broken or has elongated bolt holes.

3. Fasteners (both spoke and disc wheels). Any loose, missing, broken, cracked, stripped or otherwise ineffective fasteners.

4. Welds

a. Any cracks in welds attaching disc wheel disc to rim;

b. any cracks in welds attaching tubeless demountable rim to adapter;

c. any welded repair on aluminum wheel(s) on steering axle;

d. any welded repair other than disc to rim attachment on steel disc wheel(s) mounted on the steering axle.

U. Windshield Glazing

1. Any crack, discoloration or vision reducing matter except:

a. coloring or tinting applied at the time of manufacture;

b. any crack not over 1/4-inch wide if not intersected by any other crack;

c. any damage area not more than 3/4-inch in diameter, if not closer than 3 inches to any other such damaged area;

d. labels, stickers, decals, etc. (see 49 CFR 393.60 for exceptions).

2. These prohibitions shall not apply to the area consisting of a 2 inch border at the top, a 1 inch border at each side and the area below the topmost portion of the steering wheel.

3. Coloring or tinting of windshields and the windows to the immediate right and left of the driver is allowed, provided the parallel luminous transmittance through the colored or tinted glazing is not less than 70 percent of the light at normal incidence in those portions of the windshield or windows which are marked as having a parallel luminous transmittance of not less than 70 percent. The transmittance restriction does not apply to other windows on the commercial motor vehicle.

V. Windshield wiper—any power unit that has an inoperable wiper, or missing or damaged parts that render it ineffective.

W. Fire Extinguisher. Fire extinguisher must be properly filled and securely fastened in an approved type mount in a readily accessible location on the power unit.

X. Bi-directional triangles—three bi-directional emergency reflective triangles that conform to the requirements of Federal Motor Safety Standard No. 125, 571.125.

AUTHORITY NOTE: Promulgated in accordance with R.S. 32:1304-1310.

HISTORICAL NOTE: Promulgated by the Department of Public Safety and Corrections, Office of State Police, Safety Enforcement Section, LR 25:2438 (December 1999), amended LR 38:2558 (October 2012).

Jill P. Boudreaux
Secretary

1210#020

RULE

Department of Public Safety and Corrections Office of State Police

Operator Qualifications (LAC 55:I.503)

Under the authority of R.S. 37:3270 et seq., and in accordance with the provisions of the Administrative Procedure Act, R.S. 49:950 et seq., the Office of State Police amends Section 503 under Chapter 5 as it relates to the qualifications for individuals to conduct breath analysis. In addition to the re-promulgation, the amendments remove the requirement that they be a resident of the state of Louisiana at the time of the application. The Rule also amends the qualifications to require the operator be a POST or FLETC certified law enforcement officer, which is not currently a requirement.

Title 55

PUBLIC SAFETY

Part I. State Police

Chapter 5. Breath and Blood Alcohol Analysis Methods and Techniques

§503. Operator Qualification

Subchapter A. Analysis of Breath

A. At the time of application for certification as an operator, an individual must:

1. be an employee of a Louisiana or federal law enforcement agency;

2. have successfully completed training established by and be certified by the Peace Officer Standards and Training Council (POST) or the Federal Law Enforcement Training Center (FLETC);

3. be at least 18 years of age;

4. be a high school graduate or satisfactorily pass the General Education Development (GED) test or an equivalent or higher educational background;

5. attain a score of 75 percent or better on a 16-hour operator's training course conducted by the applied technology unit or any other course approved by the applied

technology unit. Course material to be covered will be taken from the *Chemical Test for Intoxication Training Manual* and/or the *Training Manual for the Intoxilyzer 5000*. However, if an individual has already successfully completed a training course in chemical testing, the individual may attend a specified course in the operation of the Intoxilyzer 5000. To successfully complete a 16-hour training course and be certified to conduct breath analysis, the individual must:

a. obtain a 75 percent score on the written examination covering course material;

b. obtain a 75 percent score on the actual operation of the instrument and practical examination (running of an unknown alcohol solution). Both the written and the practical examination will be made up by the instructors of the applied technology unit.

AUTHORITY NOTE: Promulgated in accordance with R.S. 37:3270, et seq.

HISTORICAL NOTE: Promulgated by the Department of Public Safety and Corrections, Office of State Police, LR 4:390 (October 1978), amended LR 6:663 (November 1980), amended by the Department of Public Safety and Corrections, Office of State Police, LR 11:256 (March 1985), LR 14:362 (June 1998), re-promulgated LR 14:442 (July 1998), amended LR 17:672 (July 1991), re-promulgated LR 17:796 (August 1991), amended LR 27:1929 (November 2001), LR 32:1906 (October 2006), LR 38:2562 (October 2012).

Jill P. Boudreaux
Undersecretary

1210#107

RULE

Department of Transportation and Development Professional Engineering and Land Surveying Board

Examinations and Experience (LAC 46:LXI.707,
709, 901, 903, 907, 909, 1301, 1509 and 1701)

Under the authority of the Louisiana professional engineering and land surveying licensure law, R.S. 37:681 et seq., and in accordance with the Louisiana Administrative Procedure Act, R.S. 49:950 et seq., the Louisiana Professional Engineering and Land Surveying Board has amended its rules contained in LAC 46:LXI.Chapters 7, 9, 13, 15, and 17.

This is a technical revision of existing rules under which LAPELS operates. These changes clarify the examination and experience requirements for certification and licensure of individuals.

Title 46

PROFESSIONAL AND OCCUPATIONAL STANDARDS

Part LXI. Professional Engineers and Land Surveyors Chapter 7. Bylaws

§707. Board Organization

A. - D.4. ...

E. Committees. The board may establish standing committees, including but not limited to the following: executive committee, civil engineering committee, other disciplines engineering committee, land surveying committee, engineer intern committee, liaison and law

review committee, education/accreditation committee, finance committee, nominations and awards committee, complaint review committees, continuing professional development committee, architect-engineer liaison committee, and firm licensure committee. The board may also establish ad hoc committees from time to time as necessary.

1. - 3.b.ii. ...

4. Land Surveying Committee. The chairman of the board may appoint not less than two members to the land surveying committee. All members of the land surveying committee shall be professional land surveyors. The land surveying committee shall:

a. - d. ...

e. recommend passing scores for the examinations on the Louisiana laws of land surveying.

5. - 13. ...

AUTHORITY NOTE: Promulgated in accordance with R.S. 37:688.

HISTORICAL NOTE: Promulgated by the Department of Transportation and Development, Board of Registration for Professional Engineers and Land Surveyors, LR 2:52 (February 1976), amended LR 5:110 (May 1979), LR 11:1179 (December 1985), LR 19:54 (January 1993), LR 21:1353 (December 1995), amended by the Department of Transportation and Development, Professional Engineering and Land Surveying Board, LR 27:1024 (July 2001), LR 30:1707 (August 2004), LR 33:2788 (December 2007), LR 35:1908 (September 2009), LR 37:2411 (August 2011), LR 38:2563 (October 2012).

§709. Executive Director

A. - B. ...

C. Duties of the Executive Director. The executive director shall:

1. - 6. ...

7. make arrangements as required by the board for all examinations and interviews of applicants;

8. supervise the administration of the examinations;

9. - 25. ...

AUTHORITY NOTE: Promulgated in accordance with R.S. 37:688.

HISTORICAL NOTE: Promulgated by the Department of Transportation, Board of Registration for Professional Engineers and Land Surveyors, LR 2:53 (February 1976), amended LR 5:118 (May 1979), LR 11:1180 (December 1985), LR 19:55 (January 1993), LR 21:1354 (December 1995), amended by the Department of Transportation and Development, Professional Engineering and Land Surveying Board, LR 27:1025 (July 2001), LR 30:1709 (August 2004), LR 37:2412 (August 2011), LR 38:2563 (October 2012).

Chapter 9. Requirements for Certification and Licensure of Individuals and Temporary Permit to Practice Engineering

§901. Engineer Intern Certification

A. The requirements for certification as an engineer intern under the several alternatives provided in the licensure law are as follows.

1. Graduates of an Accredited Engineering Curriculum. The applicant shall be a graduate of an accredited engineering curriculum of four years or more approved by the board as being of satisfactory standing, who is of good character and reputation, who has passed the examination required by the board in the fundamentals of engineering, who was recommended for certification by a professional engineer holding a valid license to engage in the

practice of engineering issued to him/her by proper authority of a state, territory, or possession of the United States, or the District of Columbia, who has submitted an application for certification in accordance with the requirements of R.S. 37:694, and who was duly certified as an engineer intern by the board.

2. Graduates with Advanced Engineering Degree. The applicant shall be a graduate of a non-EAC/ABET accredited engineering or related science or engineering technology curriculum of four years or more approved by the board as being of satisfactory standing, who has obtained an engineering graduate degree in an engineering discipline or sub-discipline from a university having an undergraduate accredited engineering curriculum in the same discipline or sub-discipline, approved by the board as being of satisfactory standing, who is of good character and reputation, who has passed the examination required by the board in the fundamentals of engineering, who was recommended for certification by a professional engineer holding a valid license to engage in the practice of engineering issued to him/her by proper authority of a state, territory, or possession of the United States, or the District of Columbia, who has submitted an application for certification in accordance with the requirements of R.S. 37:694, and who was duly certified as an engineer intern by the board.

3. Other Non-EAC/ABET Engineering Graduates. The applicant shall be a graduate of a non-EAC/ABET accredited engineering curriculum of four years or more approved by the board as being of satisfactory standing, who has a specific record of four years or more of verifiable progressive experience obtained subsequent to graduation, on engineering projects of a level and scope satisfactory to the board, who is of good character and reputation, who has passed the examination required by the board in the fundamentals of engineering, who was recommended for certification by a professional engineer holding a valid license to engage in the practice of engineering issued to him/her by proper authority of a state, territory, or possession of the United States, or the District of Columbia, and having a personal knowledge of his engineering experience, who has submitted an application for certification in accordance with the requirements of R.S. 37:694, and who was duly certified as an engineer intern by the board.

B. ...

AUTHORITY NOTE: Promulgated in accordance with R.S. 37:688.

HISTORICAL NOTE: Promulgated by the Department of Transportation and Development, Board of Registration for Professional Engineers and Land Surveyors, LR 2:352 (November 1976), amended LR 5:114 (May 1979), LR 5:365 (November 1979), LR 6:735 (December 1980), LR 7:644 (December 1981), amended by the Department of Transportation and Development, Professional Engineering and Land Surveying Board, LR 27:1027 (July 2001), LR 30:1711 (August 2004), LR 32:1618 (September 2006), LR 37:2412 (August 2011), LR 38:2563 (October 2012).

§903. Professional Engineer Licensure

A. The requirements for licensure as a professional engineer under the two alternatives provided in the licensure law are as follows:

1. the applicant for licensure as a professional engineer shall be an engineer intern, or an individual who meets the qualifications to be an engineer intern, who has a

verifiable record of four years or more of progressive experience obtained subsequent to meeting the educational and applicable experience qualifications to be an engineer intern on engineering projects of a level and scope satisfactory to the board, who is of good character and reputation, who has passed the examination required by the board in the principles and practice of engineering in the discipline of engineering in which licensure is sought, who was recommended for licensure by five personal references, three of whom are professional engineers who have personal knowledge of the applicant's engineering experience and character and ability, and who has submitted an application for licensure in accordance with the requirements of R.S. 37:694, and who was duly licensed as a professional engineer by the board; or

A.2. - B. ...

AUTHORITY NOTE: Promulgated in accordance with R.S. 37:688.

HISTORICAL NOTE: Promulgated by the Department of Transportation and Development, Board of Registration for Professional Engineers and Land Surveyors, LR 2:352 (November 1976), amended LR 5:114 (May 1979), LR 5:365 (November 1979), LR 6:735 (December 1980), LR 7:644 (December 1981), LR 10:804 (October 1984), LR 11:362 (April 1985), LR 19:56 (January 1993), amended by the Department of Transportation and Development, Professional Engineering and Land Surveying Board, LR 27:1028 (July 2001), LR 30:1712 (August 2004), LR 32:1619 (September 2006), LR 37:2412 (August 2011), LR 38:2564 (October 2012).

§907. Land Surveyor Intern Certification

A. A land surveyor intern shall be either:

1. a graduate holding a baccalaureate degree from a curriculum of four years or more who has completed at least 30 semester credit hours, or the equivalent, in land surveying, mapping, and real property courses approved by the board, who is of good character and reputation, who has passed the examination required by the board in the fundamentals of land surveying, who was recommended for certification by a professional land surveyor holding a valid license to engage in the practice of land surveying issued to him/her by proper authority of a state, territory, or possession of the United States, or the District of Columbia, who has submitted an application for certification in accordance with the requirements of R.S. 37:694, and who was duly certified as a land surveyor intern by the board; or

A.2. - B. ...

AUTHORITY NOTE: Promulgated in accordance with R.S. 37:688.

HISTORICAL NOTE: Promulgated by the Department of Transportation and Development, Board of Registration for Professional Engineers and Land Surveyors, LR 2:352 (November 1976), amended LR 5:114 (May 1979), LR 5:365 (November 1979), LR 6:735 (December 1980), LR 7:644 (December 1981), LR 10:90 (February 1984), LR 16:773 (September 1990), amended by the Department of Transportation and Development, Professional Engineering and Land Surveying Board, LR 27:1028 (July 2001), LR 30:1712 (August 2004), LR 32:1619 (September 2006), LR 37:2413 (August 2011), LR 38:2564 (October 2012).

§909. Land Surveyor Licensure

A. The requirements for licensure as a professional land surveyor under the two alternatives provided in the licensure law are as follows:

1. an applicant for licensure as a professional land surveyor shall be a land surveyor intern, or an individual who meets the qualifications to be a land surveyor intern,

who is of good character and reputation, who has a verifiable record of four years or more of combined office and field experience in land surveying including two years or more of progressive experience on land surveying projects under the supervision of a professional land surveyor, who has passed the oral examination required by the board, who has passed the examinations required by the board in the principles and practice of land surveying and Louisiana laws of land surveying, and who was recommended for licensure by five personal references (at least three of whom must be professional land surveyors who have personal knowledge of the applicant), who has submitted an application for licensure in accordance with R.S. 37:694, and who was duly licensed as a professional land surveyor by the board; or

2. the applicant shall be an individual who holds a valid license to engage in the practice of land surveying issued to him/her by the proper authority of a state, territory, or possession of the United States, or the District of Columbia, based on requirements that do not conflict with the provisions of the licensure law, and which were of a standard not lower than that specified in the applicable licensure law in effect in Louisiana at the time such license was issued, who is of good character and reputation, who has passed the examinations required by the board in the fundamentals of land surveying, principles and practice of land surveying and Louisiana laws of land surveying, who has submitted an application for licensure in accordance with the requirements of R.S. 37:694, and if the state, territory, or possession, or the District of Columbia in which he/she is licensed will accept the licenses issued by the board on a comity basis, and who was duly licensed as a professional land surveyor by the board.

B. ...

AUTHORITY NOTE: Promulgated in accordance with R.S. 37:688.

HISTORICAL NOTE: Promulgated by the Department of Transportation and Development, Board of Registration for Professional Engineers and Land Surveyors, LR 2:244 (August 1976), amended LR 2:352 (November 1976), LR 5:114 (May 1979), LR 6:735 (December 1980), LR 7:645 (December 1981), LR 11:362 (April 1985), LR 16:773 (September 1990), LR 19:56 (January 1993), amended by the Department of Transportation and Development, Professional Engineering and Land Surveying Board, LR 27:1029 (July 2001), LR 30:1713 (August 2004), LR 32:1619 (September 2006), LR 35:1909 (September 2009), LR 37:2413 (August 2011), LR 38:2564 (October 2012).

Chapter 13. Examinations

§1301. General

A. - E. ...

F. The board may require applicants to demonstrate their knowledge of the laws and rules of the board, and the English language. Applicants must be able to speak and write the English language. Proficiency in English may be evidenced by possession of a baccalaureate degree taught exclusively in English, or by passage of both the TOEFL (Test of English as a Foreign Language) paper based exam with a score of 550 or better (213 or better on the TOEFL computer based exam) and the TSE (Test of Spoken English) exam with a score of 45 or better. The TOEFL and TSE representative is TOEFL AND TSE Services, Educational Testing Service, P.O. Box 6151, Princeton, NJ 08541-6151, telephone: (609) 771-7100. The TOEFL/TSE code for this agency is 8425. Applicants requesting a waiver from the TOEFL and/or TSE requirements must submit a written

request and supporting reasoning to the board. A waiver from the TOEFL and/or TSE requirements may be granted by the board upon receipt of one of the following:

1. a passing score on the Graduate Record Examination (GRE); or

2. transcripts which verify the successful completion of 6 full-time semesters (6 credit hours per semester) toward a graduate engineering degree in the United States.

AUTHORITY NOTE: Promulgated in accordance with R.S. 37:688.

HISTORICAL NOTE: Promulgated by the Department of Transportation and Development, Board of Registration for Professional Engineers and Land Surveyors, LR 5:113 (May 1979), amended LR 7:647 (December 1981), LR 11:363 (April 1985), LR 16:774 (September 1990), LR 19:57 (January 1993), amended by the Department of Transportation and Development, Professional Engineering and Land Surveying Board, LR 27:1030 (July 2001), LR 30:1714 (August 2004), LR 35:1909 (September 2009), LR 37:2413 (August 2011), repromulgated 37:2752 (September 2011), amended LR 38:2565 (October 2012).

Chapter 15. Experience

§1509. Experience at Time of Application

A. Experience must not be anticipated.

B. For applicants for professional engineer licensure under §903.A.1 of these rules, the “verifiable record of four years or more of progressive experience obtained subsequent to meeting the educational and applicable experience qualifications to be an engineer intern” must be gained by the time of licensure. Such applicant is required to have gained a minimum of three years and four months of such experience by the time of the application.

C. For applicants for professional land surveyor licensure under §909.A.1 of these rules, the “verifiable record of four years or more of combined office and field experience in land surveying including two years or more of progressive experience on land surveying projects under the supervision of a professional land surveyor” must be gained by the time of licensure. Such applicant is required to have gained a minimum of three years and four months of such experience by the time of the application.

AUTHORITY NOTE: Promulgated in accordance with R.S. 37:688.

HISTORICAL NOTE: Promulgated by the Department of Transportation and Development, Professional Engineering and Surveying Board, LR 27:1031 (July 2001), amended LR 30:1716 (August 2004), LR 37:2413 (August 2011), LR 38:2565 (October 2012).

Chapter 17. Applications and Fees

§1701. Applications

A. - E. ...

F. An application for licensure may be considered incomplete by the board. The applicant may be denied admission to an examination until the information submitted in the application has been investigated and replies have been received from references. The board may require additional information and documents it considers necessary for the proper evaluation of an application.

G. - I. ...

AUTHORITY NOTE: Promulgated in accordance with R.S. 37:688.

HISTORICAL NOTE: Promulgated by the Department of Transportation and Development, Board of Registration for Professional Engineers and Land Surveyors, LR 5:112 (May 1979), amended LR 5:365 (November 1979), LR 7:646 (December 1981), LR 11:362 (April 1985), LR 19:57 (January 1993), amended by the

Donna D. Sentell
Executive Director

1210#010

RULE

**Department of Wildlife and Fisheries
Office of the Secretary**

Wild Seafood Certification Program (LAC 76:I.709)

Editor’s Note: Section 709 is being repromulgated to correct a citation error. The Rule can be viewed in its entirety on pages 1999-2002 of the August 2012 *Louisiana Register*.

The secretary of the Department of Wildlife and Fisheries hereby establishes the Louisiana Wild Seafood Certification Program (R.S. 56:578.15). This program shall establish rules and guidelines throughout the seafood supply chain that will enable the state of Louisiana through its various agencies to certify seafood products possessing the program label are taken, landed, and processed in Louisiana. This seafood certification program strives to increase consumer confidence and increase demand for Louisiana seafood. The primary mission with this origin based certification program is to build a unified brand that will attract not only consumers but also food service and seafood distribution buyers who want to be sure they are sourcing the best tasting seafood in the world—Louisiana seafood.

The secretary of the Department of Wildlife and Fisheries is authorized to take any and all necessary steps to promulgate and effectuate this final Rule, including but not limited to, the filing of the Fiscal and Economic Impact Statement, the filing of the Notice of Intent and final Rule and the preparation of reports and correspondence to other agencies of government.

Title 76

WILDLIFE AND FISHERIES

**Part I. Wildlife and Fisheries Commission
and Agencies Thereunder**

**Chapter 7. Louisiana Wild Seafood Certification
Program**

§709. Monitoring and Enforcement

A. Upon submission of permit application, LDWF shall validate the applicant’s required licenses and permits and check for any LWSCP related convictions. Any violations found shall be treated in a manner consistent with Section E of this provision

B. Program applicable LDWF, LDHH, and LDAF violations shall be reported to LWSCP program monitors on a regular basis. Any convictions found shall be treated in a manner consistent with Section E of this provision.

C. Product containing the LWSCP label, and all required records associated with such product, must be made available upon request of any LDWF, LDAF, or LDHH agent for inspection and sampling to ensure certification

standards are being followed. Failure to comply shall result in removal of the product from the market [R.S. 56:578.15(B)] and shall be considered a record keeping violation as described in Section E of this provision.

D. Product samples may be taken to conduct DNA or protein based country of origin tests. Discovery of any foreign product shall be considered as commingling under Section E of this provision and may result in fines and penalties notwithstanding those associated with LWSCP.

E. LWSCP Violations

1. Any violation of the above LWSCP program rules shall constitute a class 1 violation under the authority of R.S. 56:23. The provisions of this Section do not exempt any person from other laws, rules, regulation, and license requirements for this or other jurisdictions.

2. If any required licenses or permits (LDWF, LDAF, LDHH) are revoked or temporarily suspended, the participant shall be automatically removed from the the renewal application process. LWSCP and shall not be able to use the LWSCP logo. When the license(s) or permit(s) are reinstated, participant can be reinstated into the LWSCP via

3. The following program violations involving LWSCP labeled seafood product shall result in its seizure: commingling non-certified seafood with certified seafood, intentional misrepresentation of program seafood, any trademark infringement practices with LWSCP trademark and trade name, fraudulent trip tickets and/or record keeping, and short weight violations. Any seizures or forfeitures of LWSCP labeled seafood product or materials shall be disposed of in accordance with LAC 76:I.B.305.

4. The department shall not issue a permit to any person convicted of the following offenses for the specified length of time from date of conviction.

Offense	Ineligible Period
Commingling non-certified seafood into certified program packaging	36 months
Misrepresentation of program seafood	36 months
Any trademark infringement practices with LWSCP trademark and trade name	36 months
Falsification or lack of trip tickets or other sales records, invoices, or bills of lading required by the program	36 months
Submission of fraudulent LWSCP application	36 months
Short weights	First offense 12 months; second offense 36 months
Scale tampering	First offense 12 months; second offense 36 months
Not adhering to labeling guidelines	First offense 12 months; second offense 36 months

AUTHORITY NOTE: Promulgated in accordance with R.S. 56:578.15 and R.S. 56:23.

HISTORICAL NOTE: Promulgated by the Department of Wildlife and Fisheries, Office of the Secretary, LR 38:2001 (August 2012), repromulgated LR 38:2566 (October 2012).

Robert J. Barham
Secretary

1208#015

RULE

**Department of Wildlife and Fisheries
Wildlife and Fisheries Commission**

Calcasieu Lake Oyster Harvester Permit (LAC 76:VII.533)

The Wildlife and Fisheries Commission does hereby promulgate rules and regulations relative to the Calcasieu Lake Oyster Harvester Permit. Authority to establish such rules and regulations is vested in the Wildlife and Fisheries Commission by R.S. 56:6 and R.S. 56:435.1.1.

Title 76

WILDLIFE AND FISHERIES

Part VII. Fish and Other Aquatic Life

Chapter 5. Oysters

§533. Calcasieu Lake Oyster Harvester Permit

A. Any oyster taken from the Calcasieu Lake Public Oyster Area for commercial purposes during the open season shall only be taken by a person legally issued a Calcasieu Lake Oyster Harvester Permit by the department. The permit does not grant any rights to the oyster resource or any rights to harvest oysters from the waters of the state and shall not be sold, exchanged, or otherwise transferred. The permit is valid for one calendar year, beginning on January 1 and expiring on December 31 of the same calendar year. The permit may be obtained at any time of the year until November 15 for the current license year. A permit obtained on or after November 15 of the current license year shall be valid for the remainder of the current license year and expires on December 31 of the immediately following license year. This permit is only applicable for commercial harvest. Recreational fishermen may harvest one sack per person per day.

B. Applications. Initial application for the permit shall be made to the department. To be eligible for this permit the applicant must hold current and valid licenses and permits required for the harvest of oysters, including a commercial fisherman license and an oyster harvester license.

C. Operations. Vessels engaged in an activity for which this permit is required must have onboard the vessel the valid original permit and shall show the permit upon demand to a duly authorized agent of the department.

D. Enforcement. The penalties for violation of these commission regulations pertaining to taking, possessing, recording or reporting of landings or selling oysters from Calcasieu Lake shall be as provided for in R.S. 56:435.1.1(E).

AUTHORITY NOTE: Promulgated in accordance with R.S. 56:6 and R.S. 56:435.1.1.

HISTORICAL NOTE: Promulgated by the Department of Wildlife and Fisheries, Wildlife and Fisheries Commission, LR 37:3065 (October 2011), LR 38:2567 (October 2012).

Ann L. Taylor
Chair

1210#031

RULE

**Department of Wildlife and Fisheries
Wildlife and Fisheries Commission**

Yo-Yo and Trotline Regulations (LAC 76:VII.134)

The Louisiana Wildlife and Fisheries Commission hereby adopts regulations for yo-yo's and trotlines in Black Lake, Clear Lake and Prairie Lake (Natchitoches Parish), Caddo Lake (Caddo Parish), Chicot Lake (Evangeline Parish), D'Arbonne Lake (Union Parish), and Lake St. Joseph (Tensas Parish), Louisiana.

Title 76

WILDLIFE AND FISHERIES

Part VII. Fish and Other Aquatic Life

Chapter 1. Freshwater Sport and Commercial Fishing

§134. Black Lake, Clear Lake, Prairie Lake, Caddo Lake, Chicot Lake, D'Arbonne Lake, and Lake St. Joseph

A. The following regulations are applicable to the use of yo-yo's and trigger devices when used in Black Lake, Clear Lake and Prairie Lake (Natchitoches Parish), Caddo Lake (Caddo Parish), Chicot Lake (Evangeline Parish), D'Arbonne Lake (Union Parish), and Lake St. Joseph (Tensas Parish), Louisiana.

1. No more than 50 yo-yos or trigger devices shall be allowed per person.

2. Except for those devices that are attached to a privately owned pier, boathouse, seawall, or dock, each yo-yo or trigger device shall be clearly tagged with the name, address, and telephone number of the owner or user.

3. When in use, each yo-yo or trigger device shall be checked at least once every 24 hours, and all fish and any other animal caught or hooked, shall be immediately removed from the device.

4. Except for those devices that are attached to a privately owned pier, boathouse, seawall, or dock, each yo-yo or trigger device must be re-baited at least once every 24 hours.

5. Except for those metal objects located above the water that are affixed to a private pier, dock, houseboat, or other manmade structure which is designed for fishing, no yo-yo or trigger device shall be attached to any metal object.

6. Except for a metal object used strictly in the construction of a pier, boathouse, seawall, or dock, no metal object which is driven into the lake bottom, a stump, tree, or the shoreline shall be used to anchor a yo-yo or trigger device.

7. Except for those devices that are attached to a privately owned pier, boathouse, seawall, or dock, when not being used in accordance with the provisions of this Section, each yo-yo or trigger device shall be removed from the waterbody immediately.

B. The following regulations are applicable to the use of trotlines when used in Black Lake, Clear Lake and Prairie Lake (Natchitoches Parish), Caddo Lake (Caddo Parish),

Chicot Lake (Evangeline Parish), D'Arbonne Lake (Union Parish), and Lake St. Joseph (Tensas Parish), Louisiana.

1. All trotlines shall be clearly tagged with the name, address, and phone number of the owner or user and the date of placement. The trotline shall be marked on each end with a floating object that is readily visible.

2. At any given time, no person shall set more than three trotlines with a maximum of 50 hooks each.

3. All trotlines shall have an eight-foot cotton leader on each end of the trotline.

4. Except for those metal objects located above the water that are affixed to a private pier, dock, houseboat, or other manmade structure which is designed for fishing, no trotline shall be attached to any metallic object.

5. Each trotline shall be attended daily when in service.

6. When not in use, each trotline shall be removed from the waterbody by the owner or user.

C. A violation of any of the provisions of this Section shall be a class one violation, except there shall be no imprisonment. In addition, any device found in violation of this Paragraph shall be immediately seized by and forfeited to the department.

AUTHORITY NOTE: Promulgated in accordance with R.S. 56:326.3 and 56:6(32).

HISTORICAL NOTE: Promulgated by the Department of Wildlife and Fisheries, Wildlife and Fisheries Commission, LR 38:2567 (October 2012).

Ann L. Taylor
Chairman

1210#030

Notices of Intent

NOTICE OF INTENT

Department of Agriculture and Forestry Office of Agriculture and Environmental Sciences

Definition for the Advisory Commission on Pesticides
(LAC 7:XXIII.103)

In accordance with the provisions of the Administrative Procedure Act, R.S. 49:950 et seq., and with the enabling statute, R.S. 3:3203, the Commissioner of Agriculture and Forestry proposes to amend regulations regarding pesticides to restore the definition of "application". The definition was originally published in the *Louisiana Register*, Volume 35, No. 04, April 20, 2009 and subsequently inadvertently removed from the rules in December, 2011.

Title 7

AGRICULTURE AND ANIMALS

Part XXIII. Pesticides

Chapter 1. Authority, Pesticide Declarations, Definitions

§103. Definitions

A. - B. ...

* * *

Application—the activities directly related to the administering of a pesticide, including activities leading up to the actual administration of the pesticide (pre-application activities), the actual administering of the pesticide (application activities), and those occurring after the administering of the pesticide (post-application activities). Application activities include those such as the actual administering of the pesticide by any method, such as spraying or topical use.

a. Pre-application activities include those such as: arranging for the application; mixing and loading the pesticide; transporting or storing the pesticides; and necessary preparations for the application of the pesticide such as employee notification, workers and handlers training, decontamination, use and care of personal protective equipment, emergency information, and heat stress management.

b. Post-application activities include those such as: restricted-entry intervals; responsibilities related to worker training, notification, and decontamination; providing emergency assistance; transporting or storing the pesticides; and disposing of any excess pesticides, spray mix, equipment wash waters, pesticide containers, and other materials containing the pesticide.

* * *

AUTHORITY NOTE: Promulgated in accordance with R.S. 3:3202 and 3:3203.

HISTORICAL NOTE: Promulgated by the Department of Agriculture, Advisory Commission on Pesticides, LR 9:171 (April 1983), amended by the Department of Agriculture and Forestry, Advisory Commission on Pesticides, LR 15:76 (February 1989), LR 27:2085 (December 2001), amended by the Department of Agriculture and Forestry, Office of Agriculture and Environmental

Sciences, Advisory Commission on Pesticides, LR 35:626 (April 2009), amended by Department of Agriculture and Forestry, Office of Agricultural and Environmental Sciences, Advisory Commission on Pesticides, LR 37:3466 (December 2011), amended LR 38:

Family Impact Statement

It is anticipated that the proposed action will have no significant effect on the (1) stability of the family, (2) authority and rights of parents regarding the education and supervision of their children, (3) functioning of the family, (4) family earnings and family budget, (5) behavior and personal responsibility of children, or (6) ability of the family or a local government to perform the function as contained in the proposed action.

Small Business Statement

It is anticipated that the proposed action will not have a significant adverse impact on small businesses as defined in the Regulatory Flexibility Act. The agency, consistent with health, safety, environmental and economic factors has considered and, where possible, utilized regulatory methods in drafting the proposed action to accomplish the objectives of applicable statutes while minimizing any anticipated adverse impact on small businesses.

Public Comments

Interested persons may submit written comments, data, opinions, and arguments regarding the proposed action. Written submissions are to be directed to David Fields, Department of Agriculture and Forestry, 5825 Florida Boulevard, Baton Rouge, LA 70806 and must be received no later than 4:00 p.m. on November 9, 2012. No preamble regarding these proposed regulations is available.

Mike Strain, DVM
Commissioner

FISCAL AND ECONOMIC IMPACT STATEMENT FOR ADMINISTRATIVE RULES

RULE TITLE: Definition for the Advisory Commission on Pesticides

I. ESTIMATED IMPLEMENTATION COSTS (SAVINGS) TO STATE OR LOCAL GOVERNMENT UNITS (Summary)

The proposed rule change will have no direct impact on expenditures of state or local governmental units. The proposed rule change defines the term "application" in order to reflect changes in agriculture and pesticides used in this state. The definition was previously adopted in April 2009 and was inadvertently removed from the rules in December 2011.

II. ESTIMATED EFFECT ON REVENUE COLLECTIONS OF STATE OR LOCAL GOVERNMENTAL UNITS (Summary)

There will be no effect on revenue collections to the state or local governmental units as a result of the proposed rule change.

III. ESTIMATED COSTS AND/OR ECONOMIC BENEFITS TO DIRECTLY AFFECTED PERSONS OR NONGOVERNMENTAL GROUPS (Summary)

The proposed rule change is not anticipated to have any direct effect on the costs and/or economic benefits to any affected persons or non-governmental groups.

IV. ESTIMATED EFFECT ON COMPETITION AND EMPLOYMENT
(Summary)

The proposed rule change is anticipated to have no effect on competition and employment.

Dane Morgan
Assistant Commissioner
1210#029

Evan Brasseaux
Staff Director
Legislative Fiscal Office

NOTICE OF INTENT

Board of Trustees of the Assessors' Retirement Fund

Assessors' Retirement Fund (LAC 58:XIX.Chapters 1-7)

The Board of Trustees of the Assessors' Retirement Fund (fund) proposes to adopt LAC 58.XIX.Chapters 1-7 as interpretation of the provisions of the fund, as authorized by R.S. 11:1404(A). This proposed Rule is promulgated in accordance with the provisions of the Administrative Procedure Act, R.S. 49.950 et seq. The purpose of the proposed Rule is compliance with requirements imposed by the Internal Revenue Service as a condition of its favorable determination letter on the qualification of the fund under Internal Revenue Code (IRC) §401(a).

Title 58

RETIREMENT

Part XIX. Assessors' Retirement Fund

Chapter 1. General Provisions

§101. Compensation

A. Definitions. As provided under R.S. 11:1402(6), effective for limitation years beginning on or after July 1, 2007, compensation is hereby defined as follows.

Compensation—the regular pay of the member, not including any overtime or bonuses;

IRC §415 Compensation—wages, tips and other compensation required to be reported under §§6041, 6051 and 6052 of the *Internal Revenue Code* (IRC) (wages, tips and other compensation box on IRS Form W-2), during the fiscal year of the plan (the plan year or determination period).

B. Exclusions from Compensation. Compensation shall not include:

1. any amounts that are not includible in IRC §415 compensation;
2. employer contributions to a plan of deferred compensation to the extent contributions are not included in gross income of the employee for the taxable year in which contributed, or on behalf of an employee to a simplified employee pension plan and any distributions form a plan of deferred compensation;
3. amounts realized from the exercise of a non-qualified stock option, or when restricted stock (or property) held by an employee becomes freely transferable or is no longer subject to a substantial risk of forfeitures;
4. amounts realized from the sale, exchange or other disposition of stock acquired under a qualified stock option;
5. other amounts that receive special tax benefits, or contributions made by an employer (whether or not under a salary reduction agreement) towards the purchase of a IRC § 403(b) annuity contract (whether or not the contributions are excludible from the gross income of the employee); and

pre-tax amounts contributed by the employee to an IRC §125 cafeteria plan.

C. Determination of IRC §415 Compensation. IRC §415 compensation must be determined without regard to any rules under IRC §3401(a) that limit the remuneration included in wages based on the nature or location of the employment or the services performed (such as the exception for agricultural labor in IRC §3401(a)(2)).

1. For plan years beginning on and after January 1, 2001:

a. IRC §415 compensation shall include elective amounts that are not includible in the gross income of the employee under IRC §§125, 132(f)(4), 402(e)(3), 402(h), 403(b) or 457.

2. For any plan year beginning after December 31, 2001:

a. IRC §415 compensation shall not exceed the maximum amount of compensation permitted to be taken into account under IRC §401(a)(17), \$200,000 adjusted for the cost of living increases in accordance with IRC §401(a)(17)(B).

i. The cost-of-living adjustment in effect for a calendar year applies to annual compensation for the determination period that begins with or within such calendar year.

3. If a determination period consists of fewer than 12 months, as a result of a change in plan year or in the year of the termination of the plan:

a. the IRC §415 compensation limit is an amount equal to the otherwise applicable IRC §415 compensation limit multiplied by a fraction, the numerator of which is the number of months in the short determination period, and the denominator of which is 12;

4. If IRC §415 compensation for any prior determination period is taken into account in determining a participant's benefit for the current plan year, the IRC §415 compensation for such prior determination period is subject to the applicable IRC §415 compensation limit in effect for that prior period.

D. IRC §415 Compensation Paid After Severance from Employment

1. Adjusted Compensation. IRC §415 compensation shall be adjusted for the following types of compensation paid after a participant's severance from employment with the employer maintaining the plan (or any other entity that is treated as the employer pursuant to IRC §414(b), (c), (m) or (o)). However, amounts described in Paragraphs 2-8 of this Subsection may only be included in IRC §415 compensation to the extent such amounts are paid by the later of 2 1/2 months after severance from employment or by the end of the limitation year that includes the date of such severance from employment. Any other payment of compensation paid after severance from employment that is not described in the following types of compensation is not considered IRC §415 compensation within the meaning of IRC §415(c)(3), even if payment is made within the time period specified above.

2. Regular Pay. IRC §415 compensation shall include regular pay after severance from employment if:

a. the payment is regular compensation for services during the participant's regular working hours, or compensation for services outside the participant's regular

working hours (such as overtime or shift differential), commissions, bonuses, or other similar payments; and

b. the payment would have been paid to the participant prior to a severance from employment if the participant had continued in employment with the employer.

3. Leave Cashouts. Leave cashouts shall be included in IRC §415 compensation if:

a. those amounts would have been included in the definition of IRC §415 compensation if they were paid prior to the participant's severance from employment; and

b. the amounts are payment for unused accrued bona fide sick, vacation, or other leave, but only if:

i. the participant would have been able to use the leave if employment had continued.

4. Deferred Compensation. IRC §415 compensation will include deferred compensation if the compensation would have been included in the definition of IRC §415 compensation if:

a. it had been paid prior to the participant's severance from employment; and

b. the compensation is received pursuant to a nonqualified unfunded deferred compensation plan, but only if:

i. the payment would have been paid at the same time if the participant had continued in employment with the employer and only to the extent that the payment is includible in the participant's gross income.

5. Qualified Military Service. IRC §415 compensation does not include payments to an individual who does not currently perform services for the employer by reason of qualified military service (as that term is used in IRC §414(u)(1)) to the extent those payments do not exceed the amounts the individual would have received if the individual had continued to perform services for the employer rather than entering qualified military service.

6. Permanently and Totally Disabled. IRC §415 compensation does not include compensation paid to a participant who is permanently and totally disabled (as defined in IRC §22(e)(3)).

7. Amounts Earned but not Paid. IRC §415 compensation for a limitation year shall not include amounts earned but not paid during the limitation year solely because of the timing of pay periods and pay dates.

8. Lost Wages. Payments awarded by an administrative agency or court or pursuant to a bona fide agreement by an employer to compensate an employee for lost wages are IRC §415 compensation for the limitation year to which the back pay relates, but only to the extent such payments represent wages and compensation that would otherwise be included in IRC §415 compensation.

E. Limitation Year

1. The limitation year:

a. shall be the fiscal year of the fund;

b. is the period that is used to apply the limitations of IRC §415.

2. The limitation year may only be changed by amendment to the fund.

a. Furthermore, if the fund is terminated effective as of a date other than the last day of the fund's limitation year, then the fund is treated as if the fund had been amended to change its limitation year.

AUTHORITY NOTE: Promulgated in accordance with R.S. 11:1402(6), R.S. 11:1404(A), and R.S. 49.950 et seq.

HISTORICAL NOTE: Promulgated by the Board of Trustees of the Assessors' Retirement Fund, LR 39:

§103. Actuarial Equivalent

A. As provided under R.S. 11:1402(8), *actuarial equivalent* shall be defined using the following assumptions.

1. Interest shall be compounded annually at the rate of 7 1/2 percent per annum.

2. Annuity rates shall be determined on the basis of RP2000 combined healthy table set back three years for males and two years for females and uninsured.

AUTHORITY NOTE: Promulgated in accordance with R.S. 11:1402(8), 11:1404(A), and R.S. 49.950 et seq.

HISTORICAL NOTE: Promulgated by the Board of Trustees of the Assessors' Retirement Fund, LR 39:

§105. Accumulated Contributions, Rollovers

A. As provided in R.S. 11:1457(C), the following definitions are revised.

2009 RMDs of a Participant or Beneficiary—amounts that the participant or beneficiary would have been required to receive as a required minimum distribution under IRC §401(a)(9) for the 2009 distribution calendar year.

Distributee—

a. a person who is distributed benefits from the plan and shall include an employee or former employee. In addition:

i. the employee's or former employee's surviving spouse and the employee's or former employee's spouse or former spouse who is the alternate payee under a qualified domestic relations order, as defined in IRC § 414(p), are *distributees* with regard to the interest of the spouse or former spouse;

ii. a nonspouse beneficiary as designated by the member.

Eligible Retirement Plan—

a. an eligible plan under IRC §457(b) that is maintained by a state, political subdivision of a state, or any agency or instrumentality of a state or political subdivision of a state and that agrees to separately account for amounts transferred into such plan from this plan, an individual retirement account described in IRC §408(a), an individual retirement annuity described in IRC §408(b), an annuity plan described in IRC §403(a), an annuity contract described in IRC §403(b), or a qualified plan described in IRC §401(a), that accepts the distributee's eligible rollover distribution;

b. shall also apply in the case of a distribution to a surviving spouse, or to a spouse or former spouse who is the alternate payee under a qualified domestic relations order.

Eligible Rollover Distribution—any distribution of all or any portion of the balance to the credit of the distributee, except that an eligible rollover distribution does not include:

a.i. any distribution that is one of a series of substantially equal periodic payments (not less frequently than annually) made for the life (or life expectancy of the distributee or the joint lives (or joint life expectancies) of the distributee and the distributee's designated beneficiary; or

ii. for a specified period of 10 years or more;

b. any distribution to the extent such distributions is required under IRC §401(a)(9);

c. any hardship distribution attributable to elective deferrals;

d. the portion of any distribution that is not includible in gross income (determined without regard to the

exclusion for net unrealized appreciation with respect to employer securities); and

e. any other distribution(s) that is reasonably expected to total less than \$200 during a year.

B. Eligible Retirement Plan

1. Effective for distributions on or after January 1, 2007:

a. eligible retirement plan shall include the individual retirement account or annuity in the name of the deceased participant for the benefit of a nonspouse beneficiary, who receives an eligible rollover distribution from the plan on account of the death of a participant, provided that the individual retirement account or annuity is treated as an inherited IRA and that the minimum distribution rules applicable in the event the IRA owner dies before the entire interest is distributed shall apply to the transferee IRA and the transferee IRA does not provide the beneficiaries with the special rules for surviving spouse beneficiaries;

b. A Roth IRA is an eligible retirement plan with respect to distributions from the Fund that do not consist of designated Roth accounts, so long as the restrictions that apply to a transfer from a traditional IRA (non-Roth) to a Roth IRA are satisfied.

C. Eligible Rollover Distribution

1. If any portion of an eligible rollover distribution is attributable to payments or distributions from a designated Roth account, an eligible retirement plan with respect to such portion shall include only another designated Roth account of the individual from whose account the payments or distributions were made, or a Roth IRA of such individual.

2. Effective January 1, 2003, a portion of a distribution shall not fail to be an eligible rollover distribution merely because the portion consists of after-tax employee contributions that are not includible in gross income. However, such portion may be transferred only to an individual retirement account or annuity described in IRC §408(a) or (b), or to a qualified defined contribution plan described in IRC §401(a) or 403(a) that agrees to separately account for amounts so transferred, including separately accounting for the portion of such distribution that is includible in gross income and the portion of such distribution that is not so includible.

3. Effective January 1, 2007, eligible rollover distributions shall include:

a. a distribution to a nonspouse beneficiary on account of the participant's death, so long as any rollover distribution is transferred to an individual retirement account or annuity that is treated as an inherited account of the deceased participant;

b. after-tax contributions held in a plan qualified under IRC § 401(a).

4. Effective January 1, 2007, distributions from the plan that do not consist of designated Roth accounts shall be eligible rollover distributions with respect to a Roth IRA and may be rolled over to a Roth IRA, subject to the restrictions that apply to a transfer from a traditional (non-Roth) IRA to a Roth IRA.

5. During 2009, 2009 RMDs shall be treated as eligible rollover distributions for purposes of making available the direct rollover of eligible rollover distributions

that include such amount, but not for purposes of withholding federal income taxes on the amount when it is distributed.

AUTHORITY NOTE: Promulgated in accordance with R.S. 11:1404(A), R.S. 11:1457(C), and R.S. 49.950 et seq.

HISTORICAL NOTE: Promulgated by the Board of Trustees of the Assessors' Retirement Fund, LR 39:

Chapter 3. Creditable Service

§301. Death Benefits for Qualified Military Service

A. As provided under R.S. 11:1411, the following shall apply.

1. In the case of a death occurring on or after January 1, 2007, if a participant dies while performing qualified military service (as defined in IRC §414(u)), the participant's beneficiary is entitled to any additional benefits (other than benefit accruals relating to the period of qualified military service) provided under the plan as if the participant had resumed and then terminated employment on account of death.

a. Moreover, the plan will credit the participant's qualified military service as service for vesting purposes, as though the participant had resumed employment under USERRA immediately prior to the participant's death.

AUTHORITY NOTE: Promulgated in accordance with R.S. 11:1404(A), R.S. 11:1411, and the provisions of the Administrative Procedure Act, R.S. 49.950 et seq.

HISTORICAL NOTE: Promulgated by the Board of Trustees of the Assessors' Retirement Fund, LR 39:

Chapter 5. Limitation on Payment of Benefits

§501. Suspension of Benefits

A. As provided in R.S. 11:1444(D), if a member has commenced to receive distributions under R.S. 11:1444 even though he is still employed with the employer, then such member shall be given the opportunity to elect to suspend such distributions so long as he is still employed. If such member later terminates employment, he shall commence to receive minimum distributions again and shall be entitled to elect the method of receiving such distributions, with his required beginning date to be determined based on the date of his termination of employment.

AUTHORITY NOTE: Promulgated in accordance with R.S. 11:1404(A), R.S. 11:1444(D), and R.S. 49.950 et seq.

HISTORICAL NOTE: Promulgated by the Board of Trustees of the Assessors' Retirement Fund, LR 39:

§503. Required Beginning Date

A. As provided in R.S. 11:1444(E), any required beginning date occurring in 2009 shall be extended for one year.

AUTHORITY NOTE: Promulgated in accordance with R.S. 11:1444(E), R.S. 11:1404(A), and R.S. 49.950 et seq.

HISTORICAL NOTE: Promulgated by the Board of Trustees of the Assessors' Retirement Fund, LR 39:

§505. Benefit Limitations

A. As provided under R.S. 11:1458, the following provisions shall apply for limitation years beginning on or after July 1, 2007.

1. Annual Benefit—Maximum Permissible Benefit. The annual benefit, otherwise payable to a participant under the plan, at any time shall not exceed the maximum permissible benefit. If the benefit the participant would otherwise accrue in a limitation year would produce an annual benefit in excess of the maximum permissible benefit, then the benefit shall be limited (or the rate of

accrual reduced) to a benefit that does not exceed the maximum permissible benefit.

2. Adjustment if in Two Defined Benefit Plans. If the participant is, or has ever been, a participant in another qualified defined benefit plan (without regard to whether the plan has been terminated) maintained by the employer or a predecessor employer, the sum of the participant's annual benefit from all such plans may not exceed the maximum permissible benefit. Where the participant's employer-provided benefits under all such defined benefit plans (determined as of the same age) would exceed the maximum permissible benefit applicable at that age, the employer shall limit a participant's benefit in accordance with the terms of the plans.

3. Limits Grandfathered prior to July 1, 2007

a. The following sentence in Clause i of this Subparagraph applies only if the provisions of such defined benefit plans that were both adopted and in effect before April 5, 2007 satisfied the applicable requirements of statutory provisions, regulations, and other published guidance relating to IRC § 415 in effect as of the end of the last limitation year beginning before July 1, 2007, as described in U.S. Treasury Regulations § 1.415(a)-1(g)(4).

i. The application of the provisions of this Part shall not cause the maximum permissible benefit for any participant to be less than the participant's accrued benefit under all the defined benefit plans of the employer or a predecessor employer as of the end of the last limitation year beginning before July 1, 2007 under provisions of the plans that were both adopted and in effect before April 5, 2007.

AUTHORITY NOTE: Promulgated in accordance R.S. 11:1404(A), R.S. 11:1458, and R.S. 49.950 et seq.

HISTORICAL NOTE: Promulgated by the Board of Trustees of the Assessors' Retirement Fund, LR 39:

Chapter 7. Accumulated Contributions

§701. Benefit Limitations-

A. Definitions. For purposes of Chapter 7, the following definitions apply.

Annual Benefit—a benefit that is payable annually in the form of a straight life annuity.

Defined Benefit Dollar Limitation—effective for limitation years ending after December 31, 2001, \$160,000, automatically adjusted under IRC §415(d), effective January 1 of each year, as published in the *Internal Revenue Bulletin*, and payable in the form of a straight life annuity:

a. the new limitation shall apply to limitation years ending with or within the calendar year of the date of the adjustment, but a participant's benefits shall not reflect the adjusted limit prior to January 1 of that calendar year;

b. the automatic annual adjustment of the defined benefit dollar limitation under IRC §415(d) shall apply to participants who have had a separation from employment.

B. Annual Benefit Determination

1. Except as provided below, where a benefit is payable in a form other than a straight life annuity, the benefit shall be adjusted to an actuarially equivalent straight life annuity that begins at the same time as such other form of benefit and is payable on the first day of each month, before applying the limitations of this Part.

2. For a participant who has or will have distributions commencing at more than one annuity starting date, the annual benefit shall be determined as of each such annuity starting date (and shall satisfy the limitations of this Part as

of each such date), actuarially adjusting for past and future distributions of benefits commencing at the other annuity starting dates.

a. For this purpose, the determination of whether a new annuity starting date has occurred shall be made:

i. without regard to U.S. Treasury Regulations §1.401(a)-20, Q and A-10(d); and

ii. with regard to U.S. Treasury Regulations §1.415(b)1(b)(1)(iii)(B) and (C).

3. The determination of the annual benefit shall take into account Social Security supplements described in IRC §411(a)(9) and benefits transferred from another defined benefit plan, other than transfers of distributable benefits pursuant to U.S. Treasury Regulations § 1.411(d)-4, Q and A-3(c), but shall disregard benefits attributable to employee contributions or rollover contributions.

C. Actuarial Adjustment. No actuarial adjustment to the benefit shall be made for:

1. survivor benefits payable to a surviving spouse under a qualified joint and survivor annuity to the extent such benefits would not be payable if the participant's benefit were paid in another form;

2. benefits that are not directly related to retirement benefits (such as a qualified disability benefit, preretirement incidental death benefits, and postretirement medical benefits); or

3. the inclusion in the form of benefit of an automatic benefit increase feature, provided the form of benefit is not subject to IRC §417(e)(3) and would otherwise satisfy the limitations of this Part, and the plan provides that the amount payable under the form of benefit in any limitation year shall not exceed the limits of this Part applicable at the annuity starting date, as increased in subsequent years pursuant to IRC §415(d);

a. for this purpose, an automatic benefit increase feature is included in a form of benefit if the form of benefit provides for automatic, periodic increases to the benefits paid in that form.

D. Actuarial Equivalent—Straight Life Annuity

1. Effective for distributions in plan years beginning after December 31, 2003, the determination of actuarial equivalence of forms of benefit other than a straight life annuity shall be made in accordance with Subparagraph a of this Paragraph.

a. The straight life annuity that is actuarially equivalent to the participant's form of benefit shall be determined under this Subparagraph if the form of the participant's benefit is either:

i. a nondecreasing annuity (other than a straight life annuity) payable for a period of not less than the life of the participant (or, in the case of a qualified pre-retirement survivor annuity, the life of the surviving spouse); or

ii. an annuity that decreases during the life of the participant merely because of:

(a) the death of the survivor annuitant (but only if the reduction is not below 50 percent of the benefit payable before the death of the survivor annuitant); or

(b) the cessation or reduction of Social Security supplements or qualified disability payments (as defined in IRC §401(a)(11)).

2. For limitation years beginning before July 1, 2007, the actuarially equivalent straight life annuity is equal to the

annual amount of the straight life annuity commencing at the same annuity starting date that has the same actuarial present value as the participant's form of benefit computed using whichever of the following produces the greater annual amount:

a. the interest rate and mortality table (or other tabular factor) specified in the plan for adjusting benefits in the same form; and

b. 5 percent interest rate assumption and the applicable mortality table defined in the plan for that annuity starting date.

3. For limitation years beginning on or after July 1, 2007, the actuarially equivalent straight life annuity is equal to the greater of:

a. the annual amount of the straight life annuity (if any) payable to the participant under the plan commencing at the same annuity starting date as the participant's form of benefit; and

b. the annual amount of the straight life annuity commencing at the same annuity starting date that has the same actuarial present value as the participant's form of benefit, computed using a 5 percent interest rate assumption and the applicable mortality table defined in the plan for that annuity starting date.

AUTHORITY NOTE: Promulgated in accordance with the provisions of R.S. 11:1404(A) and R.S. 49.950 et seq.

HISTORICAL NOTE: Promulgated by the Board of Trustees of the Assessors' Retirement Fund, LR 39:

§703. Rollover of Returned Contributions

A. As provided in R.S. 11:1445(G):

1. distributee, eligible retirement plan and eligible rollover distribution shall be defined in provisions adopted by the board pursuant to R.S. 11:1457;

2. an eligible rollover distribution shall be transferred in a direct rollover to an eligible retirement plan if so directed by the distributee. The board shall provide distributees with the opportunity to direct such direct rollover.

AUTHORITY NOTE: Promulgated in accordance with the provisions of R.S. 11:1404(A), R.S. 11:1445(G), R.S. 11:1457, and R.S. 49.950 et seq.

HISTORICAL NOTE: Promulgated by the Board of Trustees of the Assessors' Retirement Fund, LR 39:

§705. Repayment of Withdrawn Accumulated Contributions

A. As provided in R.S. 11:1455(B), payment may be made directly by the member or may be made on the member's behalf:

1. in a single sum payment by an individual retirement account; or

2. annuity; or

3. by a plan qualified under IRC §§401(a), 403(a), 403(b), or 457(g).

AUTHORITY NOTE: Promulgated in accordance with the provisions of R.S. 11:1404(A), R.S. 11:1455(B), and the Administrative Procedure Act, R.S. 49.950 et seq.

HISTORICAL NOTE: Promulgated by the Board of Trustees of the Assessors' Retirement Fund, LR 39:

Family Impact Statement

These proposed rules should not have any known or foreseeable impact on any family as defined by R.S. 49:972(D), or on family formation, stability and autonomy. There should be no known or foreseeable effect on: the

tability of the family; the authority and rights of parents regarding the education and supervision of their children; the functioning of the family; on family earnings and family budget; the behavior and responsibility of children; or the ability of the family or a local government to perform the function as contained in the proposed Rule.

Small Business Statement

It is anticipated that the proposed Rule will not have a significant adverse impact on small businesses as defined in the Regulatory Flexibility Act. The agency, consistent with health, safety, environmental and economic factors, has considered and, where possible, utilized regulatory methods in drafting the proposed Rule to accomplish the objectives of applicable statutes while minimizing any anticipated adverse impact on small businesses.

Public Comments

Interested persons may submit written comments to Nannette Menou, P.O. Box 14699, Baton Rouge, LA 70898-4699. She is responsible for responding to inquiries regarding this proposed Rule.

Public Hearing

A public hearing on this proposed Rule is scheduled for November 26, 2012 at 2:00 p.m., at 3060 Valley Creek, Baton Rouge, LA. At that time all interested persons will be afforded an opportunity to submit data, views or arguments either orally or in writing. The deadline for receipt of all written comments is 4:30 p.m. on the next business day following the public hearing.

Terry Baker
President

FISCAL AND ECONOMIC IMPACT STATEMENT FOR ADMINISTRATIVE RULES RULE TITLE: Assessors' Retirement Fund

I. ESTIMATED IMPLEMENTATION COSTS (SAVINGS) TO STATE OR LOCAL GOVERNMENT UNITS (Summary)

The proposed rule change is anticipated to result in an increase in expenditures for the Louisiana Assessor's Retirement Fund in the amount of \$5,000 in FY 13. The increase in expenditures is for professional services, including attorney fees to prepare the rules for the State Register. The purpose of the rule change is to codify current practices and to comply with Internal Revenue Service requirements for qualification of the Assessors' Retirement Fund under Section 401(a) of the Internal Revenue Code.

II. ESTIMATED EFFECT ON REVENUE COLLECTIONS OF STATE OR LOCAL GOVERNMENTAL UNITS (Summary)

There will be no effect on revenue collections to state or local governmental units as a result of the proposed rule change.

III. ESTIMATED COSTS AND/OR ECONOMIC BENEFITS TO DIRECTLY AFFECTED PERSONS OR NONGOVERNMENTAL GROUPS (Summary)

The proposed rule change is anticipated to have no economic costs or benefits to any persons.

IV. ESTIMATED EFFECT ON COMPETITION AND EMPLOYMENT (Summary)

The proposed rule change is anticipated to have no effect on competition or employment.

Glenn M. Waguespack
Vice President
1210#048

Evan Brasseaux
Staff Director
Legislative Fiscal Office

NOTICE OF INTENT

Department of Children and Family Services Division of Programs Licensing Section

Penalty for the Operation of an Unlicensed Facility
(LAC 67:III.7302, 7355 and V.6704, 6953, 7103 and 7303)

The Department of Children and Family Services (DCFS), Division of Programs, Licensing Section in accordance with provisions of the Administrative Procedure Act, R.S. 49:953(A) proposes to amend the Louisiana Administrative Code (LAC), Title 67, Part III, Subpart 21 Child Care Licensing, and Part V, Subpart 8 Residential Licensing to comply with the provisions of Act 599 of the 2012 Regular Legislative Session.

Act 599 mandates that whoever operates any child care facility or child-placing agency, as defined in R.S. 46:1403, without a valid license issued by the department shall be fined not less than \$1,000 for each day of such offense. In accordance with this mandate, the department shall amend Sections 7302 and 7355 of Part III, and Sections 6953, 7103, 7303 of Part V. Section 6704 shall be adopted to include provisions for this penalty in Chapter 67, Maternity Home.

Title 67

SOCIAL SERVICES

Part III. Economic Stability

Subpart 21. Child Care Licensing

Chapter 73. Day Care Centers

Subchapter A. Licensing Class "A" Regulations for Child Care Centers

§7302. Authority

A. - B.1. ...

2. As mandated by R.S. 46:1421, whoever operates any child care facility or child-placing agency as defined in R.S. 46:1403, including any child day care center, without a valid license issued by the department shall be fined not less than \$1,000 per day for each day of such offense.

C. - F.6. ...

AUTHORITY NOTE: Promulgated in accordance with R.S. 46:1401 et seq.

HISTORICAL NOTE: Promulgated by the Department of Health and Human Resources, Office of the Secretary, Division of Licensing and Certification, LR 13:246 (April 1987), amended by the Department of Social Services, Office of the Secretary, Bureau of Licensing, LR 20:450 (April 1994), LR 24:2345 (December 1998), LR 29:1107 (July 2003), repromulgated by the Department of Social Services, Office of Family Support, LR 33:2755 (December 2007), amended LR 36:332 (February 2010), LR 36:847 (April 2010), amended by the Department of Children and Family Services, Division of Programs, LR 37:811 (March 2011), amended by the Department of Children and Family Services, Division of Programs, LR 39:

Subchapter B. Licensing Class "B" Regulations for Child Care Centers

§7355. Authority

A. - A.9. ...

B. Penalties. As mandated by R.S. 46:1421, whoever operates any child care facility or child-placing agency as defined in R.S. 46:1403, including any child day care center, without a valid license issued by the department shall be fined not less than \$1,000 per day for each day of such offense.

C. - F.6. ...

AUTHORITY NOTE: Promulgated in accordance with R.S. 46:1401 et seq.

HISTORICAL NOTE: Promulgated by the Department of Health and Human Resources, Office of the Secretary, Division of Licensing and Certification, LR 13:246 (April 1987), amended by the Department of Social Services, Office of the Secretary, LR 18:970 (September 1992), LR 26:1635 (August 2000), repromulgated by the Department of Social Services, Office of Family Support, LR 33:2770 (December 2007), amended LR 36:333 (February 2010), LR 36:849 (April 2010), amended by the Department of Children and Family Services, Division of Programs, LR 39:

Part V. Child Welfare

Subpart 8. Residential Licensing

Chapter 67. Maternity Home

§6704. Authority

A. Penalties

1. All maternity homes, including facilities owned or operated by any governmental, profit, nonprofit, private, or church agency shall be licensed.

2. As mandated by R.S. 46:1421, whoever operates any child care facility or child-placing agency as defined in R.S. 46:1403, including any maternity home, without a valid license issued by the department shall be fined not less than \$1,000 per day for each day of such offense.

AUTHORITY NOTE: Promulgated in accordance with R.S. 46:1421.

HISTORICAL NOTE: Promulgated by the Department of Children and Family Services, Division of Programs, LR 39:

Chapter 69. Child Residential Care, Class B

§6953. Authority

A. - B.1. ...

2. As mandated by R.S. 46:1421, whoever operates any child care facility or child-placing agency as defined in R.S. 46:1403, including any child residential facility, without a valid license issued by the department shall be fined not less than \$1,000 for each day of such offense.

C. - C.3. ...

AUTHORITY NOTE: Promulgated in accordance with R.S. 36:477 and R.S. 46:1401 et seq.

HISTORICAL NOTE: Promulgated by the Department of Social Services, Office of the Secretary, Bureau of Licensing, LR 27:1565 (September 2001), repromulgated by the Department of Social Services, Office of the Secretary, Bureau of Residential Licensing, LR 33:2740 (December 2007), repromulgated by the Department of Social Services, Office of Community Services, LR 35:1617 (August 2009), amended LR 36:331 (February 2010), amended by the Department of Children and Family Services, Division of Programs, LR 39:

Chapter 71. Child Residential Care, Class A

§7103. Authority

A. - A.1.a. ...

B. Penalties. As mandated by R.S. 46:1421, whoever operates any child care facility or child-placing agency as defined in R.S. 46:1403, including any child residential facility, without a valid license issued by the department shall be fined not less than \$1,000 for each day of such offense.

C. - D.3. ...

AUTHORITY NOTE: Promulgated in accordance with R.S. 36:477 and R.S. 46:1401-1424.

HISTORICAL NOTE: Promulgated by the Department of Social Services, Office of Community Service, LR 36:805 (April

2010), amended by the Department of Children and Family Services, Division of Programs, LR 39:

Chapter 73. Child Placing Agencies—General Provisions

§7303. Authority

A. - C.2. ...

D. Penalties. As mandated by R.S. 46:1421, whoever operates any child-placing agency, as defined in R.S. 46:1403, without a valid license issued by the department shall be fined not less than \$1,000 for each day of such offense.

E. - F.3. ...

AUTHORITY NOTE: Promulgated in accordance with R.S. 36:477 and ACT 64 of the 2010 Regular Legislative Session.

HISTORICAL NOTE: Promulgated by the Department of Children and Family Services, Division of Programs, Licensing Section LR 37:820 (March 2011), amended by the Department of Children and Family Services, Division of Programs, LR 39:

Family Impact Statement

1. What effect will this Rule have on the stability of the family? There will be no effect on the stability of the family.

2. What effect will this have on the authority and rights of persons regarding the education and supervision of their children? The penalty for operating a child care facility without a valid license is currently a fine of not less than \$75 and not more than \$250. This Rule increases the penalty for operating a facility without a valid license to a fine of \$1000 for each day of operation without a license. The operation of unlicensed child care facilities poses a threat to the health, safety, and welfare of children that receive out of home care in unlicensed facilities.

3. What effect will this have on the functioning of the family? There will be no effect on the functioning of the family.

4. What effect will this have on family earnings and family budget? There will be no effect on family earnings and the family budget.

5. What effect will this have on the behavior and personal responsibility of children? This Rule will have no effect on the behavior and personal responsibility of children.

6. Is the family or local government able to perform the function as contained in this proposed Rule? No, this is strictly an agency function.

Small Business Statement

The impact of the proposed Rule on small businesses as defined in the Regulatory Flexibility Act has been considered. It is estimated that the proposed action is not expected to have a significant adverse impact on small businesses. The department, consistent with health, safety, environmental and economic welfare factors has considered and, where possible, utilized regulatory methods in the drafting of the proposed Rule that will accomplish the objectives of applicable statutes while minimizing the adverse impact of the proposed Rule on small businesses.

Public Comments

All interested persons may submit written comments through, November 29, 2012, to Sammy Guillory, Deputy Assistant Secretary of Programs, Department of Children and Family Services, P.O. Box 94065, Baton Rouge, LA 70821-9065.

Public Hearing

A public hearing on the proposed Rule will be held on November 29, 2012, at the Department of Children and Family Services, Iberville Building, 627 North Fourth Street, Seminar Room 1-127, Baton Rouge, LA beginning at 9 a.m. All interested persons will be afforded an opportunity to submit data, views, or arguments, orally or in writing, at said hearing. Individuals with disabilities who require special services should contact the Bureau of Appeals at least seven working days in advance of the hearing. For assistance, call area code 225-342-4120 (Voice and TDD).

Suzy Sonnier
Secretary

FISCAL AND ECONOMIC IMPACT STATEMENT FOR ADMINISTRATIVE RULES

RULE TITLE: Penalty for the Operation of an Unlicensed Facility

I. ESTIMATED IMPLEMENTATION COSTS (SAVINGS) TO STATE OR LOCAL GOVERNMENT UNITS (Summary)

This Rule proposes to amend Louisiana Administrative Code (LAC) 67, Part III, Subpart 21 Child Care Licensing and Part V, Subpart 8, Residential Licensing to comply with the provisions of Act 599.

Act 599 of the 2012 Regular Legislative Session mandates an increase in the penalty for operating any child care facility or child-placing agency (as defined in R.S. 46:1403) without a valid license issued by the Department of Children and Family Services (DCFS) to a fine of not less than \$1,000 for each day of such offense. Therefore, in accordance with Act 599, (DCFS) shall amend Sections 7302 and 7355 of Part III, and Sections 6953, 7103, 7303 of Part V. Also, DCFS shall amend Section 6704 to include provisions for this penalty in Chapter 67, Maternity Home.

The only cost associated with this proposed rule is the cost of publishing rulemaking that is estimated to be approximately \$1,148 (\$956.66 State, \$191.34 Federal) in FY 13. This is a one-time cost that is routinely included in the department's annual operating budget.

II. ESTIMATED EFFECT ON REVENUE COLLECTIONS OF STATE OR LOCAL GOVERNMENTAL UNITS (Summary)

The department is unable to estimate the number of individuals or entities that will choose to operate in violation of the law or estimate the amount of fines which will be collected on a local level as the result of the illegal operation. Fines, if ordered by the court system, are paid to the court.

III. ESTIMATED COSTS AND/OR ECONOMIC BENEFITS TO DIRECTLY AFFECTED PERSONS OR NONGOVERNMENTAL GROUPS (Summary)

Any person or entity operating a facility, as defined in R.S. 46:1403, without a valid license issued by the department could be fined \$1,000 a day for each day of the offense. The department is unable to estimate the number of individuals or entities operating illegally or the number of days the individual or entity would choose to violate the law.

IV. ESTIMATED EFFECT ON COMPETITION AND EMPLOYMENT (Summary)

There is no estimated impact on competition and employment.

Suzy Sonnier
Secretary
1210#045

John D. Carpenter
Legislative Fiscal Officer
Legislative Fiscal Office

NOTICE OF INTENT

Department of Children and Family Services Economic Stability

Child Welfare Emergency Assistance Services Program
(LAC 67:III.5597)

In accordance with the provisions of R.S. 49:953(A) et seq., the Administrative Procedure Act, the Department of Children and Family Services, proposes to amend the LAC 67:III, Subpart 15, Chapter 55 TANF Initiatives to add Section 5597.

Section 5597 is being added to provide services for TANF eligible children who have been removed from their parents by the courts and are in need of emergency assistance to cover the urgent situation.

This Rule was made effective by an emergency rule effective September 5, 2012.

Title 67

SOCIAL SERVICES

Part III. Economic Stability

Subpart 15. Temporary Assistance for Needy Families (TANF) Initiatives

Chapter 55. TANF Initiatives

§5597. Child Welfare Emergency Assistance Services Program

A. The Child Welfare Emergency Assistance Services Program will provide services to children who are removed from their parents by the courts and are in foster care. These services include case management and planning as performed by DCFS' staff. The types of assistance that meet the emergency situation may include shelter care, foster family care or emergency shelter care including food, clothing and supervision.

B. TANF eligibility is limited to children in foster care who are in the first four months of a single placement in a twelve month period and are recipients of the Family Independence Temporary Assistance Program (FITAP) and/or Supplemental Nutrition Assistance Program (SNAP) during the first month of placement.

C. These services are TANF Eligible based on inclusion in the state's approved AFDC Emergency Assistance Program that was in effect as of August 21, 1996.

AUTHORITY NOTE: Promulgated in accordance with 42 U.S.C. 601 et seq.; P.L. 104-193., R.S. 46:231 and R.S. 36:474.

HISTORICAL NOTE: Promulgated by the Department of Children and Family Services, Economic Stability Section, LR 39:

Family Impact Statement

1. What effect will this Rule have on the stability of the family? This Rule will have no effect on the family's stability.

2. What effect will this have on the authority and rights of persons regarding the education and supervision of their children? This Rule will have no effect on the authority and rights of persons regarding the education and supervision of their children.

3. What effect will this have on the functioning of the family? This Rule will have no effect on the functioning of the family.

4. What effect will this have on family earnings and family budget? This Rule will have no effect on family earnings.

5. What effect will this have on the behavior and personal responsibility of children? This Rule will ensure the children's basic needs are met during the emergency situation.

6. Is the family or local government able to perform the function as contained in this proposed Rule? No, these functions are department functions.

Small Business Statement

The impact of the proposed Rule on small businesses as defined in the Regulatory Flexibility Act has been considered. It is estimated that the proposed action is not expected to have a significant adverse impact on small businesses. The department, consistent with health, safety, environmental and economic welfare factors has considered and, where possible, utilized regulatory methods in the drafting of the proposed Rule that will accomplish the objectives of applicable statutes while minimizing the adverse impact of the proposed Rule on small businesses.

Public Comments

All interested persons may submit written comments through, November 26, 2012, to Sammy Guillory, Deputy Assistant Secretary, Division of Programs, P.O. Box 94065, Baton Rouge, LA 70804-9065.

Public Hearing

A public hearing on the proposed Rule will be held on November 26, 2012 at the Department of Children and Family Services, Iberville Building, 627 N. 4th Street, Seminar Room 1-129, Baton Rouge, LA beginning at 9 a.m. All interested persons will be afforded an opportunity to submit data, views, or arguments, orally or in writing, at said hearing. Individuals with disabilities who require special services should contact the DCFS Appeals Unit at least seven working days in advance of the hearing. For assistance, call Area Code 225-342-4120 (Voice and TDD).

Suzy Sonnier
Secretary

FISCAL AND ECONOMIC IMPACT STATEMENT FOR ADMINISTRATIVE RULES

RULE TITLE: Child Welfare Emergency Assistance Services Program

I. ESTIMATED IMPLEMENTATION COSTS (SAVINGS) TO STATE OR LOCAL GOVERNMENT UNITS (Summary)

This rule proposes to continue the provisions of the September 3, 2012 emergency rule that amended Louisiana Administrative Code (LAC), Title 67, Part III, Subpart 15, and Chapter 55 TANF Initiatives. The proposed action stipulates that the Secretary of the Department of Children and Family Services (DCFS) has authority to add Section 5597, the Child Welfare Emergency Assistance Services program to the Temporary Assistance for Needy Families (TANF) Initiatives.

The Child Welfare Emergency Assistance Services program will provide services to children who are removed from their parents by the courts and are in foster care. Although the Child Welfare Emergency Services program is not a new program, the program services will now be eligible for TANF funding as a result of this proposed rule. Prior, the program was funded with State General Fund and Social Services Block Grant funding. As a result, there are no new costs anticipated as a result of this rule. The department anticipates the number of children receiving services will remain constant.

The only cost associated with this proposed rule is the cost of publishing rulemaking. It is anticipated that \$820 in Federal funds will be expended in SFY 12-13 for the state's administrative expense for promulgation of this proposed rule and the final rule.

II. ESTIMATED EFFECT ON REVENUE COLLECTIONS OF STATE OR LOCAL GOVERNMENTAL UNITS (Summary)

Implementation of this proposed rule will have no effect on revenue collections of State or local governmental units.

III. ESTIMATED COSTS AND/OR ECONOMIC BENEFITS TO DIRECTLY AFFECTED PERSONS OR NONGOVERNMENTAL GROUPS (Summary)

Services received by children in the Child Welfare Emergency Assistance Services program will remain the same. This proposed rule simply changes the funding sources of the program not services.

IV. ESTIMATED EFFECT ON COMPETITION AND EMPLOYMENT (Summary)

This proposed rule will not have an impact on competition and employment for low-income families.

Suzy Sonnier
Secretary
1210#044

John D. Carpenter
Legislative Fiscal Officer
Legislative Fiscal Office

NOTICE OF INTENT

**Department of Culture, Recreation and Tourism
Office of the State Library**

Cultural Resources (LAC 25:VII. Chapters 1, 3, 5, 13, 23, 27, 31, 41, 43, 45, 51, and 53)

Notice is hereby given in accordance with the provisions of the Administrative Procedure Act, R.S. 49:950 et seq., and through the authority granted in R.S. 44:718 (D), that the State Library of Louisiana proposes to change the content of LAC 25.VII.Chapters 1, 3, 5, 13, 23, 27, 31, 41, 43, 45, 51, and 53 to clarify definitions and procedures within the agency. The changes include:

1. Chapter 1 (Eligible Public) and Chapter 5 (Services)—repealing a Section in each regarding films and recordings; these Sections no longer reflect current functionality within the State Library;

2. Chapter 3 (Library Materials)—repealing a Section regarding films and recordings; also clarifying language regarding the collection of overdue and lost materials fees;

3. Chapter 13 (Louisiana Union Catalog)—repealing Sections that are no longer valid;

4. Chapter 23 (Regional Library Systems)—making the Code consistent with statute;

5. Chapter 27 (Auditorium and Conference Room Use by Public)—repealing this Chapter as the only surviving provision is present elsewhere in the code;

6. Chapter 31 (Disbursement of State Aid Grants)—clarifying definitions;

7. Chapter 41 (General Rules), regarding the Public Document Depository System—clarifying requirements of a candidate for the recorder of documents position;

8. Chapter 43 (Deposit of Publications)—more clearly defining what is and is not to be considered a public document for purposes of the depository system and clarifying the duties of agency liaisons; these changes are the result of collaboration of various librarians within the State

Library, as well as input from the depository system advisory council;

9. Chapter 45 (Depository Library System)—adding the Louisiana Tech University library as a historical depository and clarifying some language;

10. Chapter 51 (Certification), regarding the Board of Library Examiners—adding a third type of certification and clarifying the two existing types of certification and adding continuing education requirements; and

11. Chapter 53 (Examination)—bringing the Code in line with current practice; repealing §5307 (Fees) which currently requires examination candidates to pay a \$5.00 fee to take the exam; moving the following Sections in Chapter 53 into Chapter 51 as follows: §5313 moved to §5111, §5315 moved to §5109, and §5317 moved to §5105; and renumbering the following Sections in Chapter 53 as follows: §5309 moved to §5305 and §5311 moved to §5307; repealing §§5313, 5315, and 5317 because these topics are covered elsewhere in the Code.

Title 25

CULTURAL RESOURCES

Part VII. State Library

Subpart 1. Readers' Services

Chapter 1. Eligible Public

§103. Information and Loan

A. ...

B. Any citizen registered for library service with his local public library shall borrow State Library materials through his local library unless the State Library receives telephone or written authorization from a patron's parish library including facsimile or electronic mail, in which case he may borrow directly with the materials being charged to the parish library.

1. Repealed.

C. Students and faculty in institutions of higher learning, and residents and staff of other state institutions may, within the library regulations of such institutions, borrow State Library materials through those libraries.

D. ...

E. Information, reference, and loan services of the State Library are available directly to:

1. - 2. ...

3. officers and employees of agencies listed in the *Louisiana State Government Telephone Directory*;

4. - 6. ...

AUTHORITY NOTE: Adopted in accordance with R.S. 25:9 and R.S. 25:16.

HISTORICAL NOTE: Filed by the Louisiana State Library at the Office of the State Register, December 11, 1974, amended by the Department of Culture, Recreation and Tourism, State Library, LR 36:2538 (November 2010), amended by the Department of Culture, Recreation and Tourism, State Library, LR 39:

§105. Films and Recordings

Repealed.

AUTHORITY NOTE: Adopted in accordance with R.S. 25:9 and R.S. 25:16.

HISTORICAL NOTE: Filed by the Louisiana State Library at the Office of the Register, December 11, 1974, repealed by the Department of Culture, Recreation and Tourism, State Library, LR 39:

§107. Blind and Physically Handicapped

A. ...

B. This service is also extended to schools, hospitals, nursing homes and other agencies having one or more eligible persons with disabilities in their care.

C. ...

AUTHORITY NOTE: Adopted in accordance with R.S. 25:9 and R.S. 25:16.

HISTORICAL NOTE: Filed by the Louisiana State Library at the Office of the State Register, December 11, 1974, amended by the Department of Culture, Recreation and Tourism, State Library, LR 36:2538 (November 2010), LR 39:

Chapter 3. Library Materials

§301. Information and Loan of Materials

A. - A.1.a. ...

b. all are available for loan except volumes of expensive reference sets, the current editions of heavily used reference books, certain other reference books when needed pages can be photocopied, genealogy books, rare books, and books in fragile condition;

c. the normal loan period for materials is 28 days. Materials may be renewed twice for a total loan period of 84 days. Renewals will not be made on materials with reserves;

2. - 2.b....

3. newspapers. Newspapers in print may be used in the library. Although newspapers do not circulate, photocopies can be provided at \$0.10 per exposure;

4. microfilm. All microfilm, including Louisiana newspapers, Louisiana census records, some parish records such as marriage, succession, and probate, may be used in the State Library. Microfilm reader-printers are available for patrons' use. Rolls that are in duplicate circulate for 28 days with a limitation of five rolls to patron per loan;

5. - 6. ...

7. slides. All slides may be used in the State Library;

8. ...

B. Fines and fees for library materials are outlined below.

Fines and Fees	
Fine for Overdue Materials	\$0.10 per day per item up to a maximum of \$10.00 per item
Replacement Cost for Lost Materials	Replacement cost plus \$25.00 processing fee per item

NOTE: The state librarian may make exceptions to fees as deemed necessary.

1. ...

2. If an item has been published in the past five years, the retail price of the item will be considered replacement cost and charged to the user when it is three months overdue. If an item was published six or more years ago, then the current replacement cost will be charged. If an item is out-of-print, the average out-of-print cost will be considered replacement cost and charged. A processing fee is assessed to each item in addition to the replacement cost.

3. If an item is returned within the same fiscal year in which it was lost and paid, then the user is entitled to a full refund of the replacement charges but not the processing fee. No refund is available after the end of the fiscal year.

C. - C.2. ...

3. Priority for use of library meeting facilities is:

a. - d. ...

e. non-governmental agencies or individuals (may only reserve 30 days in advance).

AUTHORITY NOTE: Adopted in accordance with R.S. 25:9.

HISTORICAL NOTE: Filed by the Louisiana State Library at the Office of the State Register, December 11, 1974, amended by the Department of Culture, Recreation and Tourism, State Library LR 36:2538 (November 2010), LR 39:

§303. Films and Recordings Materials

Repealed.

AUTHORITY NOTE: Adopted in accordance with R.S. 25:9.

HISTORICAL NOTE: Filed by the Louisiana State Library at the Office of the State Register, December 11, 1974, repealed by the Department of Culture, Recreation and Tourism, State Library, LR 39:

§305. Blind and Physically Handicapped Materials

A. Library materials available include books and magazines recorded on discs, open-reel magnetic tapes, cassettes, digital cartridges, and books and magazines printed in large type and embossed in Braille. Most of these materials are provided by the Library of Congress through its national books for the blind and handicapped program.

B. - G. ...

AUTHORITY NOTE: Adopted in accordance with R.S. 25:9.

HISTORICAL NOTE: Filed by the Louisiana State Library at the Office of the State Register, December 11, 1974, amended by the Department of Culture, Recreation and Tourism, State Library, LR 36:2539 (November 2010), LR 39:

Chapter 5. Services

§501. Information and Loan Services

A. Information and loan services include:

A.1. - B.5. ...

C. Charges for Service. Services are free except for photocopying and microform prints. The charge for this service is \$0.25 per exposure; a minimum of \$1 is charged for mail orders.

D. ...

AUTHORITY NOTE: Adopted in accordance with R.S. 25:9.

HISTORICAL NOTE: Filed by the Louisiana State Library at the Office of the State Register, December 11, 1974, amended by the Department of Culture, Recreation and Tourism, State Library, LR 36:2539 (November 2010), LR 39:

§503. Films and Recordings Services

Repealed.

AUTHORITY NOTE: Adopted in accordance with R.S. 25:9.

HISTORICAL NOTE: Filed by the Louisiana State Library at the Office of the State Register, December 11, 1974, repealed by the Department of Culture, Recreation and Tourism, State Library, LR 39:

Subpart 2. Library Technical Services

Chapter 13. Louisiana Union Catalog

§1307. Information Submitted by the Louisiana Library Association

Repealed.

AUTHORITY NOTE: Adopted in accordance with R.S. 25:451 and R.S. 25:453.

HISTORICAL NOTE: Filed by the Louisiana State Library at the Office of the State Register December 11, 1974, repealed by the Department of Culture, Recreation and Tourism, State Library, LR 39:

§1309. Bi-Monthly Updates

Repealed.

AUTHORITY NOTE: Adopted in accordance with R.S. 25:451 and R.S. 25:453.

HISTORICAL NOTE: Filed by the Louisiana State Library at the Office of the State Register December 11, 1974, repealed by the Department of Culture, Recreation and Tourism, State Library, LR 39:

Subpart 3. Library Development

Chapter 23. Regional Library Systems

§2303. Qualifying Conditions

A. - A.2.g. ...

h. The director of the system must be certified by the Louisiana State Board of Library Examiners.

2.i. - 13.b. ...

AUTHORITY NOTE: Adopted in accordance with R.S. 25:9, R.S. 25:14 and R.S. 25:15.

HISTORICAL NOTE: Filed by the Louisiana State Library at the Office of the State Register, December 11, 1974, amended by the Department of Culture, Recreation and Tourism, State Library, LR 39:

Chapter 27. Auditorium and Conference Room-Use by Public

§2705. Patrons' Right to Privacy

Repealed.

AUTHORITY NOTE: Adopted in accordance with R.S. 25:9.

HISTORICAL NOTE: Filed by the Louisiana State Library at the Office of the State Register, December 11, 1974, repealed by the Department of Culture, Recreation and Tourism, State Library, LR 39:

Subpart 4. State Aid to Public Libraries Grant

Chapter 31. Disbursement of State Aid Grants

§3101. Definitions

A. ...

Audiovisual Materials—Repealed.

* * *

Free Basic Library Service—standard library service including the use of the principal circulating collection of the library, public access computers, standard reference and information services and electronic materials without charge.

* * *

AUTHORITY NOTE: Promulgated in accordance with R.S. 25:14.

HISTORICAL NOTE: Promulgated by the Department of Culture, Recreation and Tourism, Office of the State Library, LR 6:107 (March 1980), amended LR 13:392 (July 1987), LR 24:2232 (December 1998), amended by the Department of Culture, Recreation and Tourism, State Library, LR 36:2541 (November 2010), LR 39:

§3103. Submission of Applications

A. The state librarian shall establish a program of supplemental grants to libraries for the purchase of technology enhancement, electronic resources, books, audiovisual materials, newspapers, and periodicals in accordance with the provisions of this Part. The state librarian may establish rules and regulations for implementation of this program in accordance with the Administrative Procedure Act. Grants may be made from funds appropriated to the State Library for allocation to libraries as provided herein.

B. - F. ...

AUTHORITY NOTE: Promulgated in accordance with R.S. 25:14.

HISTORICAL NOTE: Promulgated by the Department of Culture, Recreation and Tourism, Office of the State Library, LR 6:108 (March 1980), amended LR 24:2232 (December 1998), amended by the Department of Culture, Recreation and Tourism, State Library, LR 36:2541 (November 2010), LR 39:

§3109. Distribution of Supplemental Grants

A. The state library shall grant funds under the provisions of this Part to any library, consolidated library system, or district library which makes application and

which is eligible for such funds as provided herein. Grants shall be made on an annual basis.

AUTHORITY NOTE: Promulgated in accordance with R.S. 25:14.

HISTORICAL NOTE: Promulgated by the Department of Culture, Recreation and Tourism, Office of the State Library, LR 6:109 (March 1980), amended LR 7:407 (August 1981), LR 13:392 (July 1987), LR 24:2232 (December 1998), amended by the Department of Culture, Recreation and Tourism, State Library, LR 39:

Subpart 5. Public Document Depository System

Chapter 41. General Rules

§4103. Organization

A. The Louisiana State Public Documents Depository Program is created as a unit of the state library under the direction of the state librarian.

AUTHORITY NOTE: Promulgated in accordance with R.S. 25:122(B).

HISTORICAL NOTE: Promulgated by the Department of Culture, Recreation and Tourism, Office of the State Library, LR 8:187 (April 1982), amended by the Department of Culture, Recreation and Tourism, State Library, LR 39:

§4105. Purpose

A. The state librarian has the duty to establish a depository system to facilitate the preservation and accessibility of state documents for public use.

AUTHORITY NOTE: Promulgated in accordance with R.S. 25:122(B).

HISTORICAL NOTE: Promulgated by the Department of Culture, Recreation and Tourism, Office of the State Library, LR 8:187 (April 1982), amended by the Department of Culture, Recreation and Tourism, State Library, LR 39:

Chapter 43. Deposit of Publications

§4301. Agency Responsibility

A. State agencies, as defined in R.S. 25:121.1, are required to deposit copies of their public documents with the recorder of documents immediately upon publication.

1. "Deposit" shall include providing a copy of digital-only publications via PDF file.

B. Academic institutions are required to deposit copies of their public documents with the recorder of documents for distribution to each historical depository only. They are also required to archive and provide public access to their own publications.

C. At the recorder's request, any state agency shall provide to the recorder of documents a complete list of its public documents.

AUTHORITY NOTE: Promulgated in accordance with R.S. 25:122(B).

HISTORICAL NOTE: Promulgated by the Department of Culture, Recreation and Tourism, Office of the State Library, LR 8:187 (April 1982), amended by the Department of Culture, Recreation and Tourism, State Library, LR 39:

§4303. Public Documents Required to be Deposited

A. ...

1. Repealed.

2. *Public Document*—informational matter for public distribution, regardless of format, method of reproduction, source, or copyright, originating in or produced with the imprint of, by the authority of, or at the total or partial expense of, any state agency, including material published with federal funds or by sub-state planning districts.

a. This definition incorporates publications released by private bodies such as research and consultant firms

under a contract with and/or under the supervision of any state agency.

b. This definition also incorporates electronic documents, which include any discrete public document published in a static digital format.

AUTHORITY NOTE: Promulgated in accordance with R.S. 25:122(B).

HISTORICAL NOTE: Promulgated by the Department of Culture, Recreation and Tourism, Office of the State Library, LR 8:187 (April 1982), amended LR 28:1577 (July 2002), amended by the Department of Culture, Recreation and Tourism, State Library, LR 36:2542 (November 2010), LR 39:

§4305. Public Documents Not Required to be Deposited

A. The recorder and state librarian have exempted certain kinds of state publications from deposit requirements. A state agency is not required to deposit the following state publications:

1. advertisements;
2. agendas;
3. alumni materials;
4. announcements, bookmarks, postcards;
5. applications;
6. articles/reports published in commercial/professional literature, e.g. JAMA;
7. artwork (graphical representations without textual information);
8. bids, responses to bids, requests for bids;
9. calendars;
10. complex relational databases;
11. contracts;
12. correspondence;
13. course schedules;
14. curriculum catalogs (program-specific only);
15. drafts of plans, reports (unless historically significant or only version available);
16. event invitations, announcements, registration forms;
17. fiction, literary criticism, or poetry, except as may be included in literary journals;
18. forms and instruction manuals for their completion;
19. fundraising materials;
20. grant proposals, bids;
21. greeting cards;
22. job listings;
23. memorabilia/realia;
24. memoranda (including email);
25. minutes of internal departmental meetings (except public meeting minutes of boards/commissions/task forces and executive meeting minutes);
26. minutes of boards/commissions/task forces and executive meetings containing confidential information (unless redacted);
27. minutes of committee meetings of boards/commissions/task forces, even if public;
28. news/press releases, public service announcements;
29. newsletters and subscriber lists meant only for employee, faculty, or student use;
30. notices of sale;
31. opinions and orders issued by state courts;
32. daily or weekly periodicals (that are summarized in monthly or quarterly publications);
33. personnel manuals;
34. photographs;

35. policy handbooks intended only for internal use;
36. presentations/speeches given at conferences, meetings;
37. programs (announcements of events, training sessions);
38. recruitment materials;
39. reprints (reissued without change);
40. stationery;
41. student publications (produced by students), except for those published by the university or college;
42. telephone directories meant only for employee, faculty, or student use;
43. unedited compilations of data or information submitted via forms or other means from individuals or entities under the regulation of a state agency;
44. volunteer newsletters; and
45. websites in their entirety.

B. Repealed.

AUTHORITY NOTE: Promulgated in accordance with R.S. 25:122(B).

HISTORICAL NOTE: Promulgated by the Department of Culture, Recreation and Tourism, Office of the State Library, LR 8:187 (April 1982), amended LR 28:1577 (July 2002), amended by the Department of Culture, Recreation and Tourism, State Library, LR 39:

§4307. Core Collection

A. ...

B. The needs of the public will be served best by distributing to all depositories those public documents which are the most useful and essential. Fewer copies of other state agency publications may be needed to meet the needs of the depository system. Therefore, in the interest of economy and efficiency, the recorder of documents with the aid of the advisory council will identify a core collection to be made available by all participating libraries.

AUTHORITY NOTE: Promulgated in accordance with R.S. 25:122(B).

HISTORICAL NOTE: Promulgated by the Department of Culture, Recreation and Tourism, Office of the State Library, LR 8:187 (April 1982), amended by the Department of Culture, Recreation and Tourism, State Library, LR 39:

§4309. Number of Copies to be Deposited

A. The recorder of documents, with the aid of the advisory council, will determine the appropriate number of copies of each public document not included in the core collection which will be required to be deposited to meet the needs of the depository program in accordance with the contract between the depository and the state librarian.

AUTHORITY NOTE: Promulgated in accordance with R.S. 25:122(B).

HISTORICAL NOTE: Promulgated by the Department of Culture, Recreation and Tourism, Office of the State Library, LR 8:187 (April 1982), amended by the Department of Culture, Recreation and Tourism, State Library, LR 39:

§4311. Liaison Officer of Agencies

A. The head of every state agency shall designate one of its staff members as the liaison officer for the agency and shall notify the recorder of documents on or before the first day of July of the identity of the liaison officer, and shall immediately notify the recorder of documents of any new liaison officer should a change occur. If a liaison officer is not appointed, the head of the agency serves as liaison by default. The liaison officer of each state agency shall have the duty to provide the recorder of documents with required

copies of publications in whatever format they were originally published.

AUTHORITY NOTE: Promulgated in accordance with R.S. 25:122(B).

HISTORICAL NOTE: Promulgated by the Department of Culture, Recreation and Tourism, Office of the State Library, LR 8:187 (April 1982), amended LR 28:1577 (July 2002), amended by the Department of Culture, Recreation and Tourism, State Library, LR 39:

§4317. Agency List of Publications

Repealed.

AUTHORITY NOTE: Promulgated in accordance with R.S. 25:122(B).

HISTORICAL NOTE: Promulgated by the Department of Culture, Recreation and Tourism, Office of the State Library, LR 8:188 (April 1982), repealed by the Department of Culture, Recreation and Tourism, State Library, LR 39:

Chapter 45. Depository Library System

§4501. Statutory Depositories

A. The State Library of Louisiana, Middleton Library at Louisiana State University in Baton Rouge, and Prescott Memorial Library at Louisiana Tech University are legally designated complete historical depository libraries. They shall receive and permanently retain at least one copy of all paper public documents received by the recorder for distribution. The State Library of Louisiana is responsible for archiving and providing permanent public access to received documents that are issued solely in digital formats.

AUTHORITY NOTE: Promulgated in accordance with R.S. 25:122(B).

HISTORICAL NOTE: Promulgated by the Department of Culture, Recreation and Tourism, Office of the State Library, LR 8:188 (April 1982), amended LR 28:1577 (July 2002), amended by the Department of Culture, Recreation and Tourism, State Library, LR 36:2542 (November 2010), LR 39:

§4503. Other Depositories

A. Any Louisiana library wishing to receive public documents through the depository system shall submit a written application to the state librarian requesting designation as either a complete depository, or a selective depository. Special depository status is limited to the David R. Poynter Legislative Research Library.

1. Complete depositories shall receive one copy of all public documents received by the recorder of documents for distribution and shall retain one copy for a minimum of five years.

2. Selective depositories shall receive one copy of the core collection and all public documents received by the recorder for distribution in the predetermined categories they select and shall retain one copy for a minimum of five years. Those libraries selecting only the core collection shall retain the latest edition of each superseding document received.

3. ...

4. Complete and selective depositories may withdraw superseded materials based on the superseded list.

AUTHORITY NOTE: Promulgated in accordance with R.S. 25:122(B).

HISTORICAL NOTE: Promulgated by the Department of Culture, Recreation and Tourism, Office of the State Library, LR 8:188 (April 1982), amended LR 28:1578 (July 2002), amended by the Department of Culture, Recreation and Tourism, State Library, LR 39:

§4507. Termination of Depository Contract

A. Termination of the contract between the State Library of Louisiana and the depository shall be by written notice six

months in advance of the proposed date of termination by either party. The state documents received shall be retained by the depository until the normal retention date, unless otherwise advised by the recorder of documents.

B. Failure of a depository to abide by the depository law, rules and regulations, and guidelines shall result in termination of the depository contract by the state librarian upon six months' written notice.

AUTHORITY NOTE: Promulgated in accordance with R.S. 25:122(B).

HISTORICAL NOTE: Promulgated by the Department of Culture, Recreation and Tourism, Office of the State Library, LR 8:188 (April 1982), amended by the Department of Culture, Recreation and Tourism, State Library, LR 36:2542 (November 2010), amended by the Department of Culture, Recreation and Tourism, State Library, LR 39:

Subpart 6. Board of Library Examiners

§5101. Types of Certification

A. The State Board of Library Examiners issues three types of certification:

1. executive;
2. temporary; and
3. provisional.

AUTHORITY NOTE: Promulgated in accordance with R.S. 25:222-223.

HISTORICAL NOTE: Promulgated by the Department of Culture, Recreation and Tourism, Office of the State Library, LR 11:250 (March 1985), amended by the Department of Culture, Recreation and Tourism, State Library, LR 39:

§5103. Executive Certification

A. The State Board of Library Examiners will issue executive certification to individuals who have:

1. Repealed.
2. a master's degree in library and information science granted by a library school accredited by the American Library Association;
3. three years executive experience in a public library after receiving the library science degree; and
4. attained a grade of at least 75 on the examination.

B. - C. Repealed.

AUTHORITY NOTE: Promulgated in accordance with R.S. 25:222-223.

HISTORICAL NOTE: Promulgated by the Department of Culture, Recreation and Tourism, Office of the State Library, LR 11:250 (March 1985), amended by the Department of Culture, Recreation and Tourism, State Library, LR 36:2543 (November 2010), amended by the Department of Culture, Recreation and Tourism, State Library, LR 39:

§5105. Temporary Certification

[Formerly §5317]

A. The State Board of Library Examiners will issue temporary certification to individuals who:

1. have a master's degree in library and information science granted by a library school accredited by the American Library Association;
2. pass the examination; but
3. do not have the three years of executive experience.

B. Individuals who have temporary certification must qualify for executive certification within three years of passing the examination.

C. Individuals must notify the State Board of Library Examiners when they complete their three years of experience to obtain their executive certification.

AUTHORITY NOTE: Promulgated in accordance with R.S. 25:222-223.

HISTORICAL NOTE: Promulgated by the Department of Culture, Recreation and Tourism, Office of the State Library, LR 11:250 (March 1985), amended by the Department of Culture, Recreation and Tourism, State Library, LR 39:

§5107. Provisional Certification

A. The State Board of Library Examiners will issue provisional certification upon request to individuals who:

1. hold a master's degree in library and information science granted by a library school accredited by the American Library Association;
2. have at least five years of executive experience in a public library; but
3. have not passed the examination.

B. Individuals who have provisional certification must pass the examination within six months or the first time the examination is given after they are hired, whichever is later.

C. Individuals who do not pass the examination within the required timeframe will have provisional certification revoked.

AUTHORITY NOTE: Promulgated in accordance with R.S. 25:222-223.

HISTORICAL NOTE: Promulgated by the Department of Culture, Recreation and Tourism, Office of the State Library, LR 11:250 (March 1985), amended by the Department of Culture, Recreation and Tourism, State Library, LR 39:

§5109. Duration of Certification

[Formerly §5315]

A. Executive certification is issued for five years, and is renewable if the holder completes the continuing education requirements.

AUTHORITY NOTE: Promulgated in accordance with R.S. 25:222-223.

HISTORICAL NOTE: Promulgated by the Department of Culture, Recreation and Tourism, Office of the State Library, LR 11:250 (March 1985), amended by the Department of Culture, Recreation and Tourism, State Library, LR 39:

§5111. Revocation

[Formerly §5313]

A. Any certificate may be revoked for cause.

AUTHORITY NOTE: Promulgated in accordance with R.S. 25:222-223.

HISTORICAL NOTE: Promulgated by the Department of Culture, Recreation and Tourism, Office of the State Library, LR 11:250 (March 1985), amended by the Department of Culture, Recreation and Tourism, State Library, LR 39:

§5113. Renewal of Executive Certification

A. In order to renew executive certification, the individual must:

1. make a written request to the State Board of Library Examiners stating professional experience since the certification was last issued or last renewed; and
2. show evidence of completing continuing education requirements as provided in LAC 25:VII.5115.

AUTHORITY NOTE: Promulgated in accordance with R.S. 25:222-223.

HISTORICAL NOTE: Promulgated by the Department of Culture, Recreation and Tourism, State Library, LR 39:

§5115. Continuing Education

A. Fifteen continuing education points are required in the five year period between issuance or renewal of executive certification.

B. Continuing Education Events—

1. academic or professional development courses, workshops, conferences, or institutes on topics related to public library management offered by universities, associations, vendors, or consortia;

2. developing and/or presenting a full-day course, workshop, or institute on a topic related to public library management (first presentation only);

3. professional publications; that is, journal articles or books on topics related to public library management; and

4. speeches or presentations before professional library groups, not including in-house presentations that are a normal part of the candidate's job responsibilities.

AUTHORITY NOTE: Promulgated in accordance with R.S. 25:222-223.

HISTORICAL NOTE: Promulgated by the Department of Culture, Recreation and Tourism, State Library, LR 39:

Chapter 53. Examination

§5303. Oral and Written Examinations

A. The examination is given both orally and written. The oral examination includes an interview with the candidate, and may be given on the same day as the written examination.

AUTHORITY NOTE: Promulgated in accordance with R.S. 25:222-223.

HISTORICAL NOTE: Promulgated by the Department of Culture, Recreation and Tourism, Office of the State Library, LR 11:250 (March 1985), amended by the Department of Culture, Recreation and Tourism, State Library, LR 39:

§5305. Date of Examination

[Formerly §5309]

A. The examination is given quarterly. Announcement of examinations is made at least two months before each examination is given, and all applications for that examination must be on file with the State Library not later than a month before the date of the examination. With permission of the board, a candidate may be permitted to take the examination, if the individual's application is received after the announced date.

AUTHORITY NOTE: Promulgated in accordance with R.S. 25:222-223.

HISTORICAL NOTE: Promulgated by the Department of Culture, Recreation and Tourism, Office of the State Library, LR 11:250 (March 1985), amended by the Department of Culture, Recreation and Tourism, State Library, LR 39:

§5307. Fees

Repealed.

AUTHORITY NOTE: Promulgated in accordance with R.S. 25:222-223.

HISTORICAL NOTE: Promulgated by the Department of Culture, Recreation and Tourism, Office of the State Library, LR 11:250 (March 1985), repealed by the Department of Culture, Recreation and Tourism, State Library, LR 39:

§5307. Rights of Board

[Formerly §5311]

A. The board reserves the right to cancel any announced examination if fewer than three candidates signify their desire to appear.

AUTHORITY NOTE: Promulgated in accordance with R.S. 25:222-223.

HISTORICAL NOTE: Promulgated by the Department of Culture, Recreation and Tourism, Office of the State Library, LR 11:250 (March 1985), amended by the Department of Culture, Recreation and Tourism, State Library, LR 39:

§5313. Revocation

Repealed.

AUTHORITY NOTE: Promulgated in accordance with R.S. 25:222-223.

HISTORICAL NOTE: Promulgated by the Department of Culture, Recreation and Tourism, Office of the State Library, LR

11:250 (March 1985), repealed by the Department of Culture, Recreation and Tourism, State Library, LR 39:

§5315. Duration of Certificate

Repealed.

AUTHORITY NOTE: Promulgated in accordance with R.S. 25:222-223.

HISTORICAL NOTE: Promulgated by the Department of Culture, Recreation and Tourism, Office of the State Library, LR 11:250 (March 1985), repealed by the Department of Culture, Recreation and Tourism, State Library, LR 39:

§5317. Temporary Certificate

Repealed.

AUTHORITY NOTE: Promulgated in accordance with R.S. 25:222-223.

HISTORICAL NOTE: Promulgated by the Department of Culture, Recreation and Tourism, Office of the State Library, LR 11:250 (March 1985), repealed by the Department of Culture, Recreation and Tourism, State Library, LR 39:

Family Impact Statement

The proposed rules will not affect the stability of the family, nor will they affect the authority and rights of persons regarding the education and supervision of their children. These rules will not affect the functioning of the family. They will not affect the family earnings or family budget. These rules will not affect the behavior or personal responsibility of children. Finally, neither the family nor local government will be able to perform the function as contained in this proposed Rule because the action proposed is strictly a state enforcement function.

Public Comment

Any person may submit data, views, or positions, orally or in writing, to the State Library of Louisiana at 701 North Fourth Street, Baton Rouge, LA 70802, or by telephone at (225) 342-4923 or facsimile (225) 342-3547 by November 9, 2012.

Rebecca Hamilton
State Librarian

**FISCAL AND ECONOMIC IMPACT STATEMENT
FOR ADMINISTRATIVE RULES
RULE TITLE: Cultural Resources**

I. ESTIMATED IMPLEMENTATION COSTS (SAVINGS) TO STATE OR LOCAL GOVERNMENT UNITS (Summary)

No implementation costs or savings to state or local governmental units are anticipated as a result of this rule change.

II. ESTIMATED EFFECT ON REVENUE COLLECTIONS OF STATE OR LOCAL GOVERNMENTAL UNITS (Summary)

The proposed rule change is anticipated to have a negligible effect on revenue collections of the State Library of Louisiana.

III. ESTIMATED COSTS AND/OR ECONOMIC BENEFITS TO DIRECTLY AFFECTED PERSONS OR NONGOVERNMENTAL GROUPS (Summary)

Nominal economic benefits to directly affected persons or non-governmental groups are anticipated

IV. ESTIMATED EFFECT ON COMPETITION AND EMPLOYMENT (Summary)

The proposed rule change has no known impact on competition and employment.

Rebecca Hamilton
State Librarian
1210#019

Evan Brasseaux
Staff Director
Legislative Fiscal Office

NOTICE OF INTENT

Board of Elementary and Secondary Education

**Bulletin 118—Statewide Assessment
Standards and Practices**

(LAC 28: CXI, 319, 701, 1701, 1805, 1807, 1808, 1809, 1810, 1813, 1817, 1825, 2201, 2203, 2205, 2207, 2400, 2409, 2411, 2412, 2413, and 2415)

In accordance with R.S. 49:950 et seq., the Administrative Procedure Act, notice is hereby given that the Board of Elementary and Secondary Education approved for advertisement revisions to *Bulletin 118—Statewide Assessment Standards and Practices*: new Test Security Policy language §319. E-mail Addresses for Nonpublic School Test Coordinators (STC), §701. Overview of Assessment Programs in Louisiana, §1701. Introduction, §1805. renumbered §1804. EOCT Development and Implementation Plan, §1807. renumbered §1805. Algebra I Test Structure, §1808. renumbered §1806. Biology Test Structure, §1809. renumbered §1807. English II Test Structure, §1810. renumbered §1808. Geometry Test Structure. New assessments §1809. U. S. History Test Structure and §1810. English III Test Structure will be added. Policy language will be added to §1813. Performance Standards, §1817. EOCT Achievement Level Descriptors, and §1825. EOC Administration Rules. A new assessment and new policy language will be added: Chapter 22, ACT Program to include §2201. Background, §2203. EXPLORE, §2205. PLAN, and §2207. ACT. Updates will be added to Chapter 24, Academic Skills Assessment (ASA): §2400. Sunset Provision, §2409. Achievement Levels, §2411. Performance Standards, §2412. Introduction, §2413. ASA Mathematics Achievement Level Descriptors, and §2415. ASA LAA 2 Mathematics Achievement Level Descriptors.

This document will provide new and updated statewide test information and provide easy access to that information. It was necessary to revise the bulletin at this time to incorporate new policy guidelines, edit previous policy, and revise policy language. Chapter 3, Test Security has new policy language being added to clarify that all nonpublic school test coordinators participant’s in statewide testing must provide valid e-mail addresses. Chapter 7, Assessment Program Overview testing chart was edited, revised, and updated to depict new assessment information; a revision was made to the End-Of-Course Tests (EOCT) listing to include English III and U. S. History, and updated to include EXPLORE, PLAN, and ACT as new statewide testing programs. Chapter 17, Integrated LEAP (*iLEAP*) policy language was updated to confirm that the spring 2010 administration of grade 9 *iLEAP* to grade 9 students was the last statewide administration of grade 9 *iLEAP*. Chapter 18, End-Of-Course Tests (EOCT) was revised and renumbered to allow for the addition of new EOCT assessments (English III and U. S. History); policy language will provide information and updates about the English III and U. S. History tests design, EOC Achievement Level Descriptors, and Scaled-Score Ranges. Policy language will be edited to reflect changes in EOCT Administration Rules related to Louisiana’s high school diploma endorsement testing. A new chapter featuring a new assessment and policy language is being added as Chapter 22, ACT Program. It will provide

details about the ACT being used as a statewide assessment effective spring 2013. Chapter 24, Academic Skills Assessment (ASA) will be edited to identify its' one time administration as a statewide assessment; information will be revised to include information from the spring 2012 administration. Policy language updates will provide ASA Achievement Levels and Performance Standards, Achievement Levels, Scaled-Score Ranges, and Achievement Level Descriptors for ASA Mathematics and ASA LAA 2 Mathematics.

**Title 28
EDUCATION**

Part CXI. Bulletin 118—Statewide Assessment Standards and Practices

Chapter 3. Test Security

§319. E-mail Addresses for Nonpublic School Test Coordinators

All designated school test coordinators for nonpublic schools are required to provide the department with a valid work email address. Personal email addresses (Yahoo! Hotmail, Google, etc.) will not be accepted.

AUTHORITY NOTE: Promulgated in accordance with R.S. 17:24.

HISTORICAL NOTE: Promulgated by the Department of Education, Board of Elementary and Secondary Education, LR 38:

Chapter 7. Assessment Program Overview

§701. Overview of Assessment Programs in Louisiana

A. ...

Name of Assessment Program	Assessment Population	Administered
Kindergarten Screening		
Kindergarten Developmental Readiness Screening Program (KDRSP)	Kindergarten	fall 1987–
Norm-Referenced Tests (NRTs)		
California Achievement Test (CAT/F)	grades 4, 6, and 9	spring 1988–spring 1992 (no longer administered)
California Achievement Test (CAT/5)	grades 4 and 6 grade 8	spring 1993–spring 1997 spring 1997 only (no longer administered)
Iowa Tests of Basic Skills (ITBS) (form L) and Iowa Tests of Educational Development (ITED) (form M)	grades 4, 6, 8, 9, 10, and 11	spring 1998 (no longer administered)
ITBS ITED (form M)	grades 3, 5, 6, and 7 grade 9	spring 1999–spring 2002 (no longer administered)
ITBS ITED (form B)	grades 3, 5, 6, and 7 grade 9	spring 2003–spring 2005 (no longer administered)
Criterion-Referenced Tests (CRTs)		
National Assessment of Educational Progress (NAEP)	grades 4, 8, and 12	spring 1990–
Louisiana Educational Assessment Program (LEAP)	grades 3, 5, and 7	spring 1989–spring 1998 (no longer administered)
Graduation Exit Examination (“old” GEE)	grades 10 and 11	spring 1989–spring 2003 (state administered) fall 2003– (district administered)

Name of Assessment Program	Assessment Population	Administered
Louisiana Educational Assessment Program (LEAP) (ELA and Mathematics)	grades 4 and 8	spring 1999–
LEAP (Science and Social Studies)	grades 4 and 8	spring 2000–
Graduation Exit Examination (GEE) (ELA and Mathematics)	grade 10	spring 2001–
GEE (Science and Social Studies)	grade 11	spring 2002–
End-Of-Course Tests (EOCT)	Algebra I	fall 2007–
EOCT	English II	fall 2008–
EOCT	Geometry	fall 2009–
EOCT	Biology	fall 2010–
EOCT	Applied Algebra I form	spring 2011–
EOCT	English III	fall 2011–
EOCT	U. S. History	fall 2012–
EXPLORE	grades 8 and 9	spring 2013
PLAN	grade 10	spring 2013
ACT	grade 11	spring 2013
Integrated NRT/CRT		
Integrated Louisiana Educational Assessment Program (iLEAP)	grades 3, 5, 7, and 9	spring 2006– spring 2010 (last administration of grade 9 iLEAP)
iLEAP	grade 9	
Special Population Assessments		
Louisiana Alternate Assessment, Level 1 (LAA 1)	Students with Individualized Education Programs (IEPs) who meet participation criteria in grades 3–11	spring 2000–2007
LAA 1	ELA and Mathematics (grade spans 3–4; 5–6; 7–8; 9–10); Science (grades 4, 8, and 11)	Revised spring 2008–
LAA 1 ELA and Mathematics	grade 9	spring 2010 (last administration of grade 9 LAA 1)
Louisiana Alternate Assessment, Level 2 (LAA 2) ELA and Mathematics (Grades 4, 8, and 10) Science and Social Studies (Grade 11)	grades 4, 8, 10, and 11	spring 2006–
LAA 2 ELA and Mathematics	grades 5, 6, 7, and 9	spring 2007–
LAA 2 ELA and Mathematics	grade 9	spring 2010 (last administration of grade 9 LAA 2)
LAA 2 Science and Social Studies	grades 4 and 8	spring 2008–

Name of Assessment Program	Assessment Population	Administered
Louisiana Alternate Assessment-B (LAA-B) ["out-of-level" test]	Students with Individualized Education Programs (IEPs) who met eligibility criteria in grades 3–11.	spring 1999–spring 2003 (no longer administered)
English Language Development Assessment (ELDA)	Limited English Proficient (LEP) students in grades K–12	spring 2005–
Academic Skills Assessment (ASA) and ASA LAA 2 form	Students pursuing a State-Approved Skills Certificate (SASC) or GED	spring 2012 (one administration only, spring 2012)

B. ...

AUTHORITY NOTE: Promulgated in accordance with R.S. 17:24.4.

HISTORICAL NOTE: Promulgated by the Board of Elementary and Secondary Education, Office of Student and School Performance, LR 31:1534 (July 2005), amended LR 32:235 (February 2006), LR 34:66 (January 2008), LR 34:1352 (July 2008), LR 35:218 (February 2009), LR 36:967 (May 2010), LR 37:858 (March 2011), amended LR 38:34 (January 2012), LR 39:

Chapter 17. Integrated LEAP
Subchapter A. General Provisions
§1701. Introduction

A. The NCLB Act requires the development of grade-level expectations (GLEs) or grade-level content standards at grades 3 through 8 for reading and mathematics. Louisiana has supplemented its existing content standards with grade-level expectations. To create a comprehensive system, Louisiana has developed GLEs in four content areas: English language arts, mathematics, science, and social studies, for grade levels prekindergarten through 12. NCLB further requires standards-based tests (or augmented norm-referenced tests) that measure the content standards. LEAP (grades 4 and 8) and GEE (grades 10 and 11) measure the content standards, and these tests will continue. To measure the standards and GLEs at grades 3, 5, 6, 7, and 9, however, the *Integrated LEAP (iLEAP)* tests were used, beginning in spring 2006. The *iLEAP* tests replaced The Iowa Tests, which were used to evaluate student performance in grades 3, 5, 6, 7, and 9 from spring 1998 to spring 2005. (Spring 2010 was the last administration of grade 9 *iLEAP*). In accordance with NCLB timelines, the *iLEAP* tests were implemented spring 2006. Beginning in 2007-2008, NCLB also requires tests in science: once in grades 3 through 5, once in grades 6 through 9, and once in grades 10 through 12. The term *integrated* refers to the integration of standards-based tests (CRTs) and norm-referenced tests (NRTs) into one program.

1. ...

AUTHORITY NOTE: Promulgated in accordance with R.S. 17.7 and R.S. 17:24.4(F)(2).

HISTORICAL NOTE: Promulgated by the Department of Education, Board of Elementary and Secondary Education, LR 31:1556 (July 2005), amended LR 32:238 (February 2006), LR 33:265 (February 2007), LR 39:

Chapter 18. End-of-Course Tests
Subchapter B. General Provisions
§1804. EOCT Development and Implementation Plan

Course	Test Administration	Year 1 2008– 2009	Year 2 2009– 2010	Year 3 2010– 2011	Year 4 2011– 2012	Year 5 2012– 2013
Algebra I	Field Test					
	Operational Test	√	√	√	√	√
English II	Field Test					
	Operational Test	√	√	√	√	√
Geometry	Field Test	√				
	Operational Test		√	√	√	√
Biology	Field Test		√			
	Operational Test			√	√	√
English III	Field Test			√		
	Operational Test				√	√
U.S. History	Field Test				√	
	Operational Test					√

NOTE: The field test in the table is the stand-alone field test for the initial item development.

AUTHORITY NOTE: Promulgated in accordance with R.S. 17:24.4

HISTORICAL NOTE: Promulgated by the Department of Education, Board of Elementary and Secondary Education, LR 35:215 (February 2009), LR 39:

Subchapter C. EOCT Test Design
§1805. Algebra I Test Structure

A. - C. ...

AUTHORITY NOTE: Promulgated in accordance with R.S. 17:24.4

HISTORICAL NOTE: Promulgated by the Department of Education, Board of Elementary and Secondary Education, LR 35:215 (February 2009), LR 39:

§1806. Biology Test Structure

A. - C. ...

AUTHORITY NOTE: Promulgated in accordance with R.S. 17:24.4

HISTORICAL NOTE: Promulgated by the Department of Education, Board of Elementary and Secondary Education, LR 38:35 (January 2012), LR 39:

§1807. English II Test Structure

A. - D. ...

AUTHORITY NOTE: Promulgated in accordance with R.S. 17:24.4

HISTORICAL NOTE: Promulgated by the Department of Education, Board of Elementary and Secondary Education, LR 35:215 (February 2009), LR 39:

§1808. Geometry Test Structure

A. - C. ...

AUTHORITY NOTE: Promulgated in accordance with R.S. 17:24.4

HISTORICAL NOTE: Promulgated by the Department of Education, Board of Elementary and Secondary Education, LR 37:859 (March 2011), LR 39:

§1809. U.S. History Test Structure

A. The U.S. history EOC test includes three sessions, all of which will be administered online:

1. 23-item multiple-choice session;
2. 2-item short answer session; and

3. 23-item multiple-choice session.

B. Student responses to multiple-choice items will be computer-scored.

C. Student responses to the constructed-response items will be scored by the contractor.

AUTHORITY NOTE: Promulgated in accordance with R.S. 17:24.4

HISTORICAL NOTE: Promulgated by the Department of Education, Board of Elementary and Secondary Education, LR 39:

§1810. English III Test Structure

A. The English III EOC test includes three sessions, all of which will be administered online:

1. 1 writing session, which requires a response to a prompt using the provided resources as support; and

2. 2 sessions with multiple-choice items.

B. The two multiple-choice sessions will consist of four reading passages and their related items. The passages selected will come from the following periods of American literature:

1. the Colonial Period or Revolutionary Period;
2. the National Period or the Civil War Period;
3. the Rise of Realism and Naturalism; and
4. the Early Years of the Twentieth Century.

C. The multiple-choice sessions also include discrete items. A discrete item is not passage-related but stands alone:

1. items related to using information resources; and
2. items related to writing conventions.

AUTHORITY NOTE: Promulgated in accordance with R.S. 17:24.4

HISTORICAL NOTE: Promulgated by the Department of Education, Board of Elementary and Secondary Education, LR 39:

Subchapter D. Achievement Levels and Performance Standards

§1813. Performance Standards

A. Performance standards for EOCT Algebra I, English II, Geometry, Biology, and English III tests are finalized in scaled-score form.

B. - B.4 ...

5. English III Scaled-Score Ranges

English III	
Achievement Level	Scaled-Score Ranges
Excellent	741 – 800
Good	700 – 740
Fair	661 – 699
Needs Improvement	600 – 660

AUTHORITY NOTE: Promulgated in accordance with R.S. 17:24.4

HISTORICAL NOTE: Promulgated by the Department of Education, Board of Elementary and Secondary Education, LR 35:215 (February 2009), amended LR 36:478 (March 2010), LR 37:820 (March 2011), repromulgated LR 37:1123 (April 2011), LR 38:35 (January 2012), LR 39:

Subchapter E. Achievement Level Descriptors

§1817. EOCT Achievement Level Descriptors

A. - D. ...

E. English III Achievement Level Descriptors

Excellent
Students at this achievement level generally have exhibited the ability to:
<ol style="list-style-type: none"> 1. develop essays that include relevant and accurate supporting details and reference sources; 2. produce essays that contain varied and fluent sentences; 3. revise sentences for correct use of subjunctive mood; 4. determine the main idea when it is implicit in a complex text; 5. develop conclusions based on information synthesized from the text; 6. analyze an author's use of figurative language in a complex text; 7. evaluate arguments in a complex text; 8. demonstrate an understanding of persuasive techniques; 9. evaluate claims in information resources using evidence; and 10. synthesize information from multiple information resources.
Good
Students at this achievement level generally have exhibited the ability to:
<ol style="list-style-type: none"> 1. write essays that are focused and include a clear organizational structure; 2. write essays that incorporate appropriate word choice and demonstrate audience awareness; 3. revise phrases in a sentence for correct use of parallel structure; 4. draw conclusions based on information stated in a complex text; 5. interpret figurative language in a complex text; 6. determine overall purpose of a complex text; 7. summarize information in a complex text; 8. predict outcomes based on textual evidence; 9. evaluate the usefulness of resources; and 10. determine the reliability or objectivity of information resources.
Fair
Students at this achievement level generally have exhibited the ability to:
<ol style="list-style-type: none"> 1. write essays that provide sufficient and relevant supporting details; 2. write essays that have a consistent voice and varied sentence structure; 3. revise sentences to avoid split infinitives; 4. select a synonym for a given vocabulary word in a text; 5. identify the main idea based on information directly stated in a text; 6. make simple inferences based on information in a text; 7. use reasoning skills to draw conclusions; 8. determine the meaning of figurative language in a text; 9. identify relevant information from a variety of resources; and 10. use information from graphic organizers.
Needs Improvement
Students at this achievement level are generally working toward the ability to:
<ol style="list-style-type: none"> 1. write essays that provide sufficient and relevant supporting details; 2. revise sentences to avoid split infinitives; 3. identify the main idea based on information directly stated in a text; 4. use reasoning skills to draw conclusions; and 5. identify relevant information from a variety of resources.

AUTHORITY NOTE: Promulgated in accordance with R.S. 17:24.4

HISTORICAL NOTE: Promulgated by the Department of Education, Board of Elementary and Secondary Education, LR 35:216 (February 2009), amended LR 36:478 (March 2010), LR 37:820 (March 2011), repromulgated LR 37:1123 (April 2011), LR 38:36 (January 2012), LR 39:

Subchapter F. EOCT Administrative Rules

§1825. EOC Administration Rules

A. - E. ...

F. Students who wish to retest for the Louisiana high school diploma endorsements may retest during the fall retest administration only one time for each EOC test.

AUTHORITY NOTE: Promulgated in accordance with R.S. 17:24.4

HISTORICAL NOTE: Promulgated by the Department of Education, Board of Elementary and Secondary Education, LR 36:977 (May 2010); LR 39:

Chapter 22. ACT Program

§2201. Background

A. The American College Testing (ACT) Program also known as ACT's College and Career Readiness System provides a longitudinal approach to educational and career planning through student assessment, curriculum support, and school improvement. This research-approach based solution helps schools, districts, and states improve academic measurement, student readiness, and instructional designs.

AUTHORITY NOTE: Promulgated in accordance with R.S. 17:24.4

HISTORICAL NOTE: Promulgated by the Department of Education, Board of Elementary and Secondary Education, LR 39:

§2203. EXPLORE

A. Designed to help 8th and 9th graders explore a broad range of options for their future, EXPLORE is a curriculum-based educational and career planning program that measures achievement in English, math, reading, and science. As an early indicator of college readiness, EXPLORE gives educators the means to structure high school planning and career exploration for students and parents.

AUTHORITY NOTE: Promulgated in accordance with R.S. 17:24.4

HISTORICAL NOTE: Promulgated by the Department of Education, Board of Elementary and Secondary Education, LR 39:

§2205. PLAN

A. PLAN helps 10th graders build a solid foundation for future academic and career success. PLAN is a curriculum-based educational and career planning program that measures achievement in English, math, reading, and science. PLAN is designed to help 10th graders build rigorous high school course plans and identify areas of academic need so they can stay on track for college and work success.

AUTHORITY NOTE: Promulgated in accordance with R.S. 17:24.4

HISTORICAL NOTE: Promulgated by the Department of Education, Board of Elementary and Secondary Education, LR 39:

§2207. ACT

A. The ACT is designed to assess 11th graders' general learning outcomes. The ACT is a curriculum-based educational and career planning tool that assesses mastery of state and college readiness standards. Accepted by all four-year colleges and universities, it is the college entrance test most preferred nationwide.

AUTHORITY NOTE: Promulgated in accordance with R.S. 17:24.4

HISTORICAL NOTE: Promulgated by the Department of Education, Board of Elementary and Secondary Education, LR 39:

Chapter 24. Academic Skills Assessment (ASA)

§2400. Sunset Provision

A. For the academic year 2011-2012, ASA and ASA LAA2 tests will be administered one-time only and thereafter discontinued as a statewide assessment.

AUTHORITY NOTE: Promulgated in accordance with R.S. 17.7 and 17:24(F)(2).

HISTORICAL NOTE: Promulgated by the Department of Education, Board of Elementary and Secondary Education, LR 39:

Subchapter E. Target Population

§2409. Achievement Levels

- A.1. Louisiana achievement levels are:
- Basic (Meeting the Standard);

- Approaching Basic (Approaching the Standard);
- Unsatisfactory
- Foundational
- Pre-Foundational

B. Achievement Level Definitions

1. *Basic*—a student at this level has demonstrated only the fundamental knowledge and skills needed for the next level of schooling.

2. *Approaching Basic*—a student at this level has only partially demonstrated the fundamental knowledge and skills needed for the next level of schooling.

3. *Foundational*—a student at this level has not demonstrated the fundamental knowledge and skills needed for the next level of schooling but has demonstrated the foundational knowledge and skills that can be built upon to access the grade-level curriculum.

4. *Pre-Foundational*—a student at this level has not demonstrated the fundamental knowledge and skills needed for the next level of schooling. However, the student may be developing the foundational knowledge and skills that can be built upon to access the grade-level curriculum.

5. *Unsatisfactory*—a student at this level has not demonstrated the fundamental knowledge and skills needed for the next level of schooling.

AUTHORITY NOTE: Promulgated in accordance with R.S. 17:24.4(F)(1) and (C).

HISTORICAL NOTE: Promulgated by the Department of Education, Board of Elementary and Secondary Education, LR 39:

§2411. Performance Standards

A. Performance standards for ASA English Language Arts and Mathematics are finalized in scaled-score form.

B. ASA Mathematics Achievement Levels and Scaled Score Ranges (*Field tested, but not implemented*)

Achievement Level	Mathematics
Basic	293 – 359
Approaching Basic	263 – 292
Unsatisfactory	100 – 262

C. ASA LAA 2 Mathematics Achievement Levels and Scaled Score Ranges

Achievement Level	Mathematics
Basic	293 – 340
Approaching Basic	263 – 292
Foundational	221 – 262
Pre-Foundational	100 – 220

AUTHORITY NOTE: Promulgated in accordance with R.S. 17:24.

HISTORICAL NOTE: Promulgated by the Department of Education, Board of Elementary and Secondary Education, LR 39:

Subchapter F. Achievement Level Descriptors

§2412. Introduction

A. Achievement level descriptors for Louisiana assessments were developed by committees composed of Louisiana educators who represented the subjects and grades assessed. The descriptors define what a student should know and be able to do at each achievement level for each subject assessed at a given grade level.

AUTHORITY NOTE: Promulgated in accordance with R.S. 17:391.4(B).

HISTORICAL NOTE: Promulgated by the Department of Education, Board of Elementary and Secondary Education, LR 39:

§2413. ASA Mathematics Achievement Level Descriptors

§2415. ASA LAA 2 Mathematics Achievement Level Descriptors

Basic
<p>A student at this level has demonstrated only the fundamental knowledge and skills needed for the next level of schooling.</p> <p>Students scoring at this level generally exhibit the ability to:</p> <ol style="list-style-type: none"> 1. Simplify numerical expressions involving multiple operations, using order of operations; 2. represent numbers as exponential expressions with positive, integral exponents; 3. use proportional reasoning to solve real-life problems; 4. use algebraic expressions, equations, and inequalities to describe tables and verbal statements in real-life situations; 5. solve multi-step equations and inequalities in one variable; 6. choose appropriate common units (U.S. and metric) to make measurements; 7. demonstrate understanding of precision and accuracy; 8. solve simple problems involving indirect measurement in real-life situations; 9. recognize and graph linear equations to interpret and solve real-life problems, and use appropriate terminology to describe slope, intercept, point, intersection, etc.; 10. draw translations and line reflections in a coordinate system; 11. read, organize, construct, and interpret data presented in a variety of formats and make generalizations using these representations; and 12. demonstrate a fundamental understanding of graphical representations of functions, including the relationship of the constants and coefficients in a linear function to the graph of the function.
Approaching Basic
<p>A student at this level has only partially demonstrated the fundamental knowledge and skills needed for the next level of schooling.</p> <p>Students scoring at this level generally exhibit the ability to:</p> <ol style="list-style-type: none"> 1. demonstrate understanding of different number systems, including whole numbers, integers, rational numbers, and real numbers; 2. perform basic operations with positive rational numbers; 3. determine whether problems require exact or approximate solutions; 4. recognize ratios and proportions that describe real-life situations; 5. use calculators to evaluate polynomials for given values of the variables; 6. solve single-step equations and inequalities in one variable; 7. estimate, calculate, and make measurements using common units of measure; 8. locate points on a coordinate grid; 9. recognize geometric transformations on a coordinate grid; 10. match data displays to real-life situations, and vice versa; 11. follow and interpret processes expressed in flow charts; and 12. recognize and describe coordinate graphs of functions.
Unsatisfactory
<p>A student at this level has not demonstrated the fundamental knowledge and skills needed for the next level of schooling.</p> <p>Students scoring at this level need to develop the ability to:</p> <ol style="list-style-type: none"> 1. demonstrate understanding of different number systems, including whole numbers, integers, rational numbers, and real numbers; 2. perform basic operations with positive rational numbers; 3. determine whether problems require exact or approximate solutions; 4. recognize ratios and proportions that describe real-life situations; 5. use calculators to evaluate polynomials for given values of the variables; 6. solve single-step equations and inequalities in one variable; 7. estimate, calculate, and make measurements using common units of measure; 8. locate points on a coordinate grid; 9. recognize geometric transformations on a coordinate grid; 10. match data displays to real-life situations, and vice versa; 11. follow and interpret processes expressed in flow charts; and 12. recognize and describe coordinate graphs of functions.

Basic
<p>A student at this level has demonstrated only the fundamental knowledge and skills needed for the next level of schooling.</p> <p>Students scoring at this level generally exhibit the ability to:</p> <ol style="list-style-type: none"> 1. simplify numerical expressions involving multiple operations, using order of operations; 2. represent numbers as exponential expressions with positive, integral exponents; 3. use proportional reasoning to solve real-life problems; 4. use algebraic expressions, equations, and inequalities to describe tables and verbal statements in real-life situations; 5. solve multi-step equations and inequalities in one variable; 6. choose appropriate common units (U.S. and metric) to make measurements; 7. demonstrate understanding of precision and accuracy; 8. solve simple problems involving indirect measurement in real-life situations; 9. recognize and graph linear equations to interpret and solve real-life problems, and use appropriate terminology to describe slope, intercept, point, intersection, etc.; 10. draw translational and line reflections in a coordinate system; 11. read, organize, construct, and interpret data presented in a variety of formats and make generalizations using these representations; and 12. demonstrate a fundamental understanding of graphical representations of functions.
Approaching Basic
<p>A student at this level has only partially demonstrated the fundamental knowledge and skills needed for the next level of schooling.</p> <p>Students scoring at this level generally exhibit the ability to:</p> <ol style="list-style-type: none"> 1. demonstrate understanding of different number systems, including whole numbers, integers, rational numbers, and real numbers; 2. perform basic operations with positive rational numbers; 3. determine whether problems require exact or approximate solutions; 4. recognize ratios and proportions that describe real-life situations; 5. use calculators to evaluate polynomials for given values of the variables; 6. solve single-step equations and inequalities in one variable; 7. estimate, calculate, and make measurements using common units of measure; 8. locate points on a coordinate grid; 9. recognize geometric transformations on a coordinate grid; 10. match data displays to real-life situations, and vice versa; 11. follow and interpret processes expressed in flow charts; and 12. recognize and describe coordinate graphs of functions.
Foundational
<p>A student at this level has not demonstrated the fundamental knowledge and skills needed for the next level of schooling but has demonstrated the foundational knowledge and skills that can be built upon to access the grade-level curriculum.</p> <p>Students scoring at this level generally exhibit the ability to:</p> <ol style="list-style-type: none"> 1. demonstrate some understanding of different number systems, including whole numbers, integers, rational numbers, and real numbers; 2. perform a few basic operations with positive rational numbers; 3. determine—with some consistency—whether problems require exact or approximate solutions; 4. recognize some ratios and proportions that describe real-life situations; 5. minimally use calculators to evaluate polynomials for given values of the variables; 6. solve some single-step equations and inequalities in one variable; 7. estimate, calculate, and make measurements—with a limited degree of accuracy—using common units of measure; 8. show limited skills in locating points on a coordinate grid; 9. recognize a limited number of geometric transformations on a coordinate grid; 10. match some data displays to real-life situations, and vice versa; 11. follow and interpret some processes expressed in flow charts; and 12. minimally recognize and describe coordinate graphs of functions.

AUTHORITY NOTE: Promulgated in accordance with R.S. 17:24.

HISTORICAL NOTE: Promulgated by the Department of Education, Board of Elementary and Secondary Education, LR 39:

Pre-Foundational

A student at this level has not demonstrated the fundamental knowledge and skills needed for the next level of schooling. However, the student may be developing the foundational knowledge and skills that can be built upon to access the grade-level curriculum.

Students scoring at this level need to develop the ability to:

1. demonstrate at least some understanding of different number systems, including whole numbers, integers, rational numbers, and real numbers;
2. perform at least a few basic operations with positive rational numbers;
3. determine—with at least some consistency—whether problems require exact or approximate solutions;
4. recognize at least some ratios and proportions that describe real-life situations;
5. at least minimally use calculators to evaluate polynomials for given values of the variables;
6. solve at least some single-step equations and inequalities in one variable;
7. estimate, calculate, and make measurements—with at least a limited degree of accuracy—using common units of measure;
8. show at least limited skills in locating points on a coordinate grid;
9. recognize at least a limited number of geometric transformations on a coordinate grid;
10. match at least some data displays to real-life situations; and vice versa;
11. follow and interpret at least some processes expressed in flow charts; and
12. at least minimally recognize and describe coordinate graphs of function.

AUTHORITY NOTE: Promulgated in accordance with R.S. 17:24.

HISTORICAL NOTE: Promulgated by the Department of Education, Board of Elementary and Secondary Education, LR 39:

Family Impact Statement

In accordance with Section 953 and 974 of Title 49 of the Louisiana Revised Statutes, there is hereby submitted a Family Impact Statement on the Rule proposed for adoption, repeal or amendment. All Family Impact Statements shall be kept on file in the State Board Office which has adopted, amended, or repealed a Rule in accordance with the applicable provisions of the law relating to public records.

1. Will the proposed Rule affect the stability of the family? No.
2. Will the proposed Rule affect the authority and rights of parents regarding the education and supervision of their children? No.
3. Will the proposed Rule affect the functioning of the family? No.
4. Will the proposed Rule affect family earnings and family budget? No.
5. Will the proposed Rule affect the behavior and personal responsibility of children? No.
6. Is the family or a local government able to perform the function as contained in the proposed Rule? Yes.

Small Business Statement

The impact of the proposed Rule on small businesses as defined in the Regulatory Flexibility Act has been considered. It is estimated that the proposed action is not expected to have a significant adverse impact on small businesses. The agency, consistent with health, safety, environmental, and economic welfare factors has considered and, where possible, utilized regulatory methods in the drafting of the proposed Rule that will accomplish the objectives of applicable statutes while minimizing the adverse impact of the proposed Rule on small businesses.

Public Comments

Interested persons may submit written comments via the U.S. Mail until 4:30 p.m., November 19, 2012, to Heather Cope, Executive Director, State Board of Elementary and Secondary Education, P.O. Box 94064, Capitol Station, Baton Rouge, LA 70804-9064.

Heather Cope
Executive Director

**FISCAL AND ECONOMIC IMPACT STATEMENT
FOR ADMINISTRATIVE RULES
RULE TITLE: Bulletin 118—Statewide Assessment
Standards and Practices**

I. ESTIMATED IMPLEMENTATION COSTS (SAVINGS) TO STATE OR LOCAL GOVERNMENT UNITS (Summary)

The proposed policy change will result in a cost of \$2.5 million for the administration of the ACT Program. The Department of Education will use \$1.25 million in federal funds (\$1 million from Race to the Top funds and \$250,000 from Individuals with Disabilities Education Act (IDEA) funds) and \$1.25 million in state general funds (\$1.22 million is being redirected from the testing contracts for tests that are obsolete and \$30,000 is from salaries that are being recoded to be paid from other sources of funds) to administer the program. The proposed policy changes will provide new and updated statewide test information and provide easy access to that information. It is necessary to revise the bulletin at this time to incorporate new policy guidelines, edit previous policy, and revise policy language. The ACT program is defined in Chapter 22 and includes the EXPLORE test given in the 8th and 9th grades, the PLAN test given in the 10th grade, and the ACT test given in the 11th grade.

II. ESTIMATED EFFECT ON REVENUE COLLECTIONS OF STATE OR LOCAL GOVERNMENTAL UNITS (Summary)

There will be no effect on revenue collections at the state or local governmental levels.

III. ESTIMATED COSTS AND/OR ECONOMIC BENEFITS TO DIRECTLY AFFECTED PERSONS OR NONGOVERNMENTAL GROUPS (Summary)

There should be no effect on costs and/or economic benefits to directly affected persons or non-governmental groups.

IV. ESTIMATED EFFECT ON COMPETITION AND EMPLOYMENT (Summary)

There should be no impact on competition and employment.

Beth Scioneaux
Deputy Superintendent
1210#038

Evan Brasseaux
Staff Director
Legislative Fiscal Office

NOTICE OF INTENT

Board of Elementary and Secondary Education

Bulletin 119—Louisiana School Transportation
Specifications and Procedures
(LAC 28: CXIII.Chapters 3, 19 and 31)

In accordance with R.S. 49:950 et seq., the Administrative Procedure Act, notice is hereby given that the Board of Elementary and Secondary Education approved for advertisement revisions to *Bulletin 119—Louisiana School*

Transportation Specifications and Procedures: Chapter 3, 19 and 31. The proposed revisions will eliminate tenure for School Bus Drivers hired after July 1, 2012 as required by Act 704, R.S. 17:492. In addition, R.S. 17:491 provides a clear definition of "school bus operator" in an effort to eliminate discrepancies and inconsistencies. Act 249, R.S. 17:238(C): allows a foster child to remain enrolled in the school of enrollment for the entire duration of the child's stay in the custody of the state or until the highest grade offered is completed. Act 672, R.S. 17:158(I), authorizes local school boards to provide transportation to certain students attending certain technical colleges effective August 1, 2012. The remaining changes are technical in nature.

Title 28

EDUCATION

Part CXIII. Bulletin 119—Louisiana School

Transportation Specifications and Procedures

Chapter 3. Selection and Employment of School Bus Drivers and Attendants (Aides)

§303. Certification of School Bus Drivers

- A. - C.7.b. ...
- 8. Repealed.
- C.9. - D. ...

AUTHORITY NOTE: Promulgated in accordance with R.S. 15:587, R.S. 17:15, R.S. 17:158, R.S. 17:160-161, R.S. 17:164-166, R.S. 17:432, R.S. 17:491, R.S. 17:493, R.S. 17:497, R.S. 17: 691, R.S. 32:52, R.S. 32:402, R.S. 32:408, R.S. 32:417, and R.S. 40:963 et seq.

HISTORICAL NOTE: Promulgated by the Board of Elementary and Secondary Education, LR 25:628 (April 1999), amended LR 36:1467 (July 2010), LR 37:2122 (July 2011), LR 38:749 (March 2012), LR 39:

§307. Retaining School Bus Drivers

- A. - G. ...

H. For the purposes of this Section, *school bus operator* or *school bus driver* means any employee of a city, parish, or other local public school board or other governing authority of a public elementary or secondary school whose duty it is to transport students in any school bus or activity bus to and from a school approved by the state Board of Elementary and Secondary Education or to and from any school-related activity.

AUTHORITY NOTE: Promulgated in accordance with R.S. 17:158, R.S. 17:160-161, R.S. 17:164-166, and R.S. 17:493.

HISTORICAL NOTE: Promulgated by the Board of Elementary and Secondary Education, LR 25:642 (April 1999), amended LR 36:1468 (July 2010), LR 37:2122 (July 2011), LR 38:749 (March 2012), LR 39:

§309. Tenure and Termination of Bus Drivers

- A. ...

B. School bus operators starting employment with a school system on July 1, 2012, or thereafter are not eligible for tenure and may be removed from their position as provided by the personnel policy of the employing school board.

C. Additionally, the abolition, discontinuance or consolidation of bus routes may require a reduction in force, or lay-off of one or more bus drivers. The procedure prescribed in R.S. 17:493 must be followed.

AUTHORITY NOTE: Promulgated in accordance with R.S. 17:158, R.S. 17:160-161, R.S. 17:164-166, R.S. 17:492, and 17:493.

HISTORICAL NOTE: Promulgated by the Board of Elementary and Secondary Education, LR 25:630 (April 1999), amended LR 36:1468 (July 2010), LR 39:

Chapter 19. Transporting Students

§1905. Transportation of Student in Foster Care

A. Each LEA shall establish a policy to ensure that a student who is in foster care pursuant to placement through the Department of Children and Family Services (DCFS) shall be allowed to remain enrolled in the public school in which the student was enrolled at the time he or she entered foster care for the duration of the child's stay in the custody of the state or until he completes the highest grade offered at the school, if DCFS determines that remaining in the school is in the best interest of the student.

B. If the foster care placement is outside the jurisdictional boundaries of the public school in which the student is enrolled, the governing authority of the school shall be responsible for providing free transportation for the student to and from a designated location which is within that school district and is located nearest to the student's residence.

1. The location must be determined to be appropriate by such governing authority and DCFS.

2. DCFS shall be responsible for providing the child's transportation between that location and the child's residence.

AUTHORITY NOTE: Promulgated in accordance with R.S. 17:158, R.S. 17:160-161, R.S. 17:164-166, and R.S. 17:238.

HISTORICAL NOTE: Promulgated by the Board of Elementary and Secondary Education, LR 25:635 (April 1999), amended LR 36:1476 (July 2010), LR 38:

§1907. Transportation of Student to a Community and Technical College System

A. In accordance with Revised Statute 17:158(I), each LEA may provide transportation to any full-time student who is twenty years of age or younger and attending a technical college campus, that is part of the Louisiana Community and Technical College System, within the jurisdictional boundaries of the local board.

1. If the closest technical college campus is located outside the jurisdictional boundaries of the local school board, the board may facilitate the transportation or coordinate with neighboring boards to facilitate transportation to the technical college campus.

B. The local public school board where the student resides may assess a fee to each student utilizing the Transportation services provided pursuant to this Subsection, not to exceed the actual cost of providing such transportation, including administrative costs.

C. The provisions of this section shall not apply to:

1. local public school boards in a parish with a population of more than three hundred thousand persons according to the most recent federal decennial census;

2. local public school boards in any parish that operates a parish-wide public transit system that provides sufficient service to meet the transportation needs of students attending technical colleges located in the parish.

AUTHORITY NOTE: Promulgated in accordance with R.S. 17:158, R.S. 17:160-161, R.S. 17:164-166, and R.S. 17:238, R.S. 17:158(I).

HISTORICAL NOTE: Promulgated by the Board of Elementary and Secondary Education, LR 39:

Chapter 31. Glossary of Definitions
§3101. Definitions

* * *

Manufacturer—any person engaged in the manufacturing or assembling of motor vehicles or items of motor vehicle equipment, including any person importing motor vehicle equipment for resale.

* * *

Tenured School Bus Driver—a full-time driver who has successfully completed the three-year probationary period prior to July 1, 2012.

* * *

AUTHORITY NOTE: Promulgated in accordance with R.S. 17:158, R.S. 17:160-161, R.S. 17:164-166.

HISTORICAL NOTE: Promulgated by the Board of Elementary and Secondary Education, LR 25:641 (April 1999), amended LR 36:1481 (July 2010), LR 37:2126 (July 2011), LR 39:

Family Impact Statement

In accordance with Section 953 and 974 of Title 49 of the Louisiana Revised Statutes, there is hereby submitted a Family Impact Statement on the rule proposed for adoption, repeal or amendment. All Family Impact Statements shall be kept on file in the State Board Office which has adopted, amended, or repealed a rule in accordance with the applicable provisions of the law relating to public records.

1. Will the proposed Rule affect the stability of the family? No.
2. Will the proposed Rule affect the authority and rights of parents regarding the education and supervision of their children? No.
3. Will the proposed Rule affect the functioning of the family? No.
4. Will the proposed Rule affect family earnings and family budget? No.
5. Will the proposed Rule affect the behavior and personal responsibility of children? No.
6. Is the family or a local government able to perform the function as contained in the proposed Rule? Yes.

Small Business Statement

The impact of the proposed Rule on small businesses as defined in the Regulatory Flexibility Act has been considered. It is estimated that the proposed action is not expected to have a significant adverse impact on small businesses. The agency, consistent with health, safety, environmental and economic welfare factors has considered and, where possible, utilized regulatory methods in the drafting of the proposed Rule that will accomplish the objectives of applicable statutes while minimizing the adverse impact of the proposed Rule on small businesses.

Public Comments

Interested persons may submit written comments via the U.S. Mail until 4:30 p.m., November 19, 2012, to Heather Cope, Executive Director, State Board of Elementary and Secondary Education, P.O. Box 94064, Capitol Station, Baton Rouge, LA 70804-9064.

Heather Cope
Executive Director

**FISCAL AND ECONOMIC IMPACT STATEMENT
FOR ADMINISTRATIVE RULES**

**RULE TITLE: Bulletin 119—Louisiana School
Transportation Specifications and Procedures**

I. ESTIMATED IMPLEMENTATION COSTS (SAVINGS) TO STATE OR LOCAL GOVERNMENT UNITS (Summary)

The proposed Rule change may result in an indeterminable increase in school district costs related to providing transportation to students in foster care placement. In addition, transportation of certain students attending a technical college campus may result in an indeterminable increase in costs; however, fees charged to the students being transported may offset such increase. The proposed policy changes are in accordance with several Acts from the 2012 Regular Legislative Session. Act 704 provides a clear definition of a school bus operator and eliminates tenure for school bus drivers hired after July 1, 2012. Act 249 allows foster children to remain enrolled in the public school for the duration of their stay in the custody of the state or until they complete the highest grade at the school. The extension of required transportation to students in a foster care placement could potentially increase transportation costs for a district, but the potential increase is indeterminable. Act 672 allows city, parish and other local public school boards to transport certain students attending a technical college campus in their jurisdiction for a fee not to exceed the actual cost of transportation, including administrative costs. If a district chose to provide transportation to students attending community and technical college, transportation costs could potentially increase but this provision is permissive and also allows districts the ability to charge the student for the cost of the transportation. The remaining changes are technical in nature.

II. ESTIMATED EFFECT ON REVENUE COLLECTIONS OF STATE OR LOCAL GOVERNMENTAL UNITS (Summary)

This policy will have no effect on revenue collections at the state or local government level.

III. ESTIMATED COSTS AND/OR ECONOMIC BENEFITS TO DIRECTLY AFFECTED PERSONS OR NONGOVERNMENTAL GROUPS (Summary)

Students attending technical colleges choosing to seek transportation from a city, parish and other local public school board will be charged a fee not to exceed the actual cost of transportation. The fees will be determined by the entity providing the transportation.

IV. ESTIMATED EFFECT ON COMPETITION AND EMPLOYMENT (Summary)

There will be no effect on competition or employment as a result of this Rule change.

Beth Scioneaux
Deputy Superintendent
1210#039

Evan Brasseaux
Staff Director
Legislative Fiscal Office

NOTICE OF INTENT

Board of Elementary and Secondary Education

Bulletin 126—Charter Schools—Application Process
(LAC 28:CXXXIX.512)

In accordance with R.S. 49:950 et seq., the Administrative Procedure Act, notice is hereby given that the Board of Elementary and Secondary Education approved for

advertisement revisions to *Bulletin 126—Charter Schools: §512, "Application Process for Locally Authorized Charter Schools."* The proposed policy revision will streamline and standardize the charter school applications process for local school boards.

Title 28
EDUCATION

Part CXXXIX. Bulletin 126—Charter Schools

Chapter 5. Charter School Application and Approval Process

§512. Application Process for Locally Authorized Charter Schools

A. Application Cycle

1. Effective January 1, 2013, local school boards shall accept charter applications from applicants beginning on the first Monday in August, with the initial application period remaining open until 5:00 p.m. on the last Friday in September of every year. Local school boards may request supplementary materials once the initial application has been submitted. Final decisions regarding the approval of charter applications must be made by local school boards by 5:00 p.m. on December 31 of every year. Notifications of charter proposals denied shall include written explanation of the reasons for such denial.

2. Prior to the consideration of a charter school proposal by any local school board, each charter applicant shall be afforded the opportunity to provide a written response to the independent evaluation of the application. Such response shall be available to the independent reviewers for consideration prior to issuing a final recommendation to the chartering authority.

3. If a proposal is not approved by the local school board and then also not approved by BESE within the same approval cycle, then the proposal shall be submitted to the local school board for its consideration during the next approval cycle prior to being submitted to the state board.

B. Common Charter Application

1. Each local school board shall use a common charter application developed by the department and approved by BESE, but may request additional information from applicants as needed.

2. BESE shall approve the common application to be used by local school boards by June 30 of every year. If there are no changes to be made to the common application from a previous year, BESE will not be required to vote to approve the common charter application.

C. Appeals to State Process

1. If a charter applicant believes that a local school board has not complied with the requirements in §306 of this policy, the charter applicant may submit its proposal to the state board for its review and approval as a Type 2 charter as part of the annual request for applications.

a. Upon local receipt of the application from the local charter applicant, the department shall investigate and make a determination as to whether the local school board failed to comply with §306 of this policy.

b. If the department determines that the local school board failed to comply with §306, it shall notify the local school board of that determination within 30 days, and

BESE may proceed with its own review of the charter application.

2. If the local system in which a charter group intends to apply to operate a school has received a letter grade designation of "D" or "F" or any variation thereof, then a proposal for a Type 2 charter school may be made to the state board.

D. Partnerships with the Department

1. A local school board may enter into an agreement with the Louisiana Department of Education by which the department will conduct the local school board's charter applications and evaluation process. Local school boards that have entered into such agreements shall be exempt from Subsection A of this Section, and shall instead follow timelines established by the department.

2. The department shall create the process and timeline by which such agreements can be created and implemented.

AUTHORITY NOTE: Promulgated in accordance with R.S. 17:6(A)(10), R.S. 17:3981, R.S. 17:3981, and R.S. 17:3983.

HISTORICAL NOTE: Promulgated by the Board of Elementary and Secondary Education in LR 37:869 (March 2011), amended LR 38:750 (March 2012), repromulgated LR 38:1392 (June 2012), amended LR 39:

Family Impact Statement

In accordance with Section 953 and 974 of Title 49 of the Louisiana Revised Statutes, there is hereby submitted a Family Impact Statement on the Rule proposed for adoption, repeal or amendment. All Family Impact Statements shall be kept on file in the state board office which has adopted, amended, or repealed a Rule in accordance with the applicable provisions of the law relating to public records.

1. Will the proposed Rule affect the stability of the family? No.

2. Will the proposed Rule affect the authority and rights of parents regarding the education and supervision of their children? No.

3. Will the proposed Rule affect the functioning of the family? No.

4. Will the proposed Rule affect family earnings and family budget? No.

5. Will the proposed Rule affect the behavior and personal responsibility of children? No.

6. Is the family or a local government able to perform the function as contained in the proposed Rule? No.

Small Business Statement

The impact of the proposed Rule on small businesses as defined in the Regulatory Flexibility Act has been considered. It is estimated that the proposed action is not expected to have a significant adverse impact on small businesses. The agency, consistent with health, safety, environmental and economic welfare factors has considered and, where possible, utilized regulatory methods in the drafting of the proposed Rule that will accomplish the objectives of applicable statutes while minimizing the adverse impact of the proposed Rule on small businesses.

Public Comments

Interested persons may submit written comments via the U.S. Mail until 4:30 p.m., November 19, 2012, to Heather Cope, Executive Director, State Board of Elementary and

Heather Cope
Executive Director

**FISCAL AND ECONOMIC IMPACT STATEMENT
FOR ADMINISTRATIVE RULES
RULE TITLE: Application Process**

**I. ESTIMATED IMPLEMENTATION COSTS (SAVINGS) TO
STATE OR LOCAL GOVERNMENT UNITS (Summary)**

The proposed policy revision will create a standardized timeline and application form for local school boards to authorize charter schools, and allows for agreements between local school boards and the Department of Education for the evaluation of charter applications. The adoption of this policy will cost the Department of Education approximately \$700 (printing and postage) to disseminate the policy.

**II. ESTIMATED EFFECT ON REVENUE COLLECTIONS OF STATE
OR LOCAL GOVERNMENTAL UNITS (Summary)**

This policy will have no effect on revenue collections of state or local governmental units.

**III. ESTIMATED COSTS AND/OR ECONOMIC BENEFITS TO
DIRECTLY AFFECTED PERSONS OR NONGOVERNMENTAL
GROUPS (Summary)**

No costs and/or economic benefits are anticipated for directly affected persons or non-governmental groups.

**IV. ESTIMATED EFFECT ON COMPETITION AND EMPLOYMENT
(Summary)**

This policy will have no effect on competition and employment.

Beth Scioneaux
Deputy Superintendent
1210#040

Evan Brasseaux
Staff Director
Legislative Fiscal Office

NOTICE OF INTENT

Board of Elementary and Secondary Education

Bulletin 129—The Recovery School District
(LAC 28:CXLV.505)

In accordance with R.S. 49:950 et seq., the Administrative Procedure Act, notice is hereby given that the Board of Elementary and Secondary Education approved for advertisement revisions to *Bulletin 129—The Recovery School District* §505, "Return of Schools to LEA." This revision adjusts the school performance score that schools in the Recovery School District (RSD) must achieve to be eligible to seek a transfer to their original district. Current policy states that schools completing the required five years in the RSD are eligible to seek transfer to their original district if the school has received a performance score of at least 5 points above the Academically Unacceptable School (AUS) bar for two consecutive years. The current AUS bar is 75 out of 200. Under the new policy, the AUS bar is being changed to 50 out of 150 and schools in the RSD must score a 54 for two consecutive years to be eligible for return. If the AUS bar is raised above 50, schools will be required to score 4 points above the AUS bar. These changes were made to

align these policies with the new accountability formula which rescaled the performance score range so that 100 approximates 100 percent proficiency for all students and a score of 150 represents all students demonstrating Advanced. A score of 50 is the Academically Unacceptable School bar.

**Title 28
EDUCATION**

**Part CXLV. Bulletin 129—The Recovery School District
Chapter 5. Failed Schools**

§505. Return of Schools to LEA

A. - D.1. ...

2. The school has earned for the past two consecutive years a school performance score (SPS) of 54.0 or above. If the academically unacceptable school (AUS) bar is raised above 50.0, then the school must have earned for the past two consecutive years a school performance score that is at least 4.0 points above the AUS bar as established by BESE pursuant to the statewide school and district accountability system.

D.3. - J.4. ...

AUTHORITY NOTE: Promulgated in accordance with R.S. 17:6(A)(10), R.S. 17:10.5(A)(1), R.S. 17:10.7(A)(1), R.S. 17:1990(A)(2), R.S. 17:10.5(C), and R.S. 17:10.7(C).

HISTORICAL NOTE: Promulgated by the Board of Elementary and Secondary Education, LR 37:878 (March 2011), amended LR 38:354 (February 2012), LR 38:1396 (June 2012), LR 39:

Family Impact Statement

In accordance with Section 953 and 974 of Title 49 of the Louisiana Revised Statutes, there is hereby submitted a Family Impact Statement on the Rule proposed for adoption, repeal or amendment. All Family Impact Statements shall be kept on file in the state board office which has adopted, amended, or repealed a Rule in accordance with the applicable provisions of the law relating to public records.

1. Will the proposed Rule affect the stability of the family? No.

2. Will the proposed Rule affect the authority and rights of parents regarding the education and supervision of their children? No.

3. Will the proposed Rule affect the functioning of the family? No.

4. Will the proposed Rule affect family earnings and family budget? No.

5. Will the proposed Rule affect the behavior and personal responsibility of children? No.

6. Is the family or a local government able to perform the function as contained in the proposed Rule? Yes.

Small Business Statement

The impact of the proposed Rule on small businesses as defined in the Regulatory Flexibility Act has been considered. It is estimated that the proposed action is not expected to have a significant adverse impact on small businesses. The agency, consistent with health, safety, environmental and economic welfare factors has considered and, where possible, utilized regulatory methods in the drafting of the proposed Rule that will accomplish the objectives of applicable statutes while minimizing the adverse impact of the proposed rule on small businesses.

Public Comments

Interested persons may submit written comments via the U.S. Mail until 4:30 p.m., November 19, 2012, to Heather Cope, Executive Director, State Board of Elementary and Secondary Education, P.O. Box 94064, Capitol Station, Baton Rouge, LA 70804-9064.

Heather Cope
Executive Director

FISCAL AND ECONOMIC IMPACT STATEMENT FOR ADMINISTRATIVE RULES RULE TITLE: **Bulletin 129—The Recovery School District**

I. ESTIMATED IMPLEMENTATION COSTS (SAVINGS) TO STATE OR LOCAL GOVERNMENT UNITS (Summary)

The proposed Rule change will not result in an increase in costs or savings to state or local governmental units. The revision to Section 505 of Bulletin 129: The Recovery School District adjusts the school performance score that schools in the Recovery School District (RSD) must achieve to be eligible to seek a transfer to their original district. Current policy states that schools completing the required five years in the RSD are eligible to seek transfer to their original district if the school has received a performance score of at least 5 points above the Academically Unacceptable School (AUS) bar for two consecutive years. The current AUS bar is 75 out of 200. Under the new policy, the AUS bar is being changed to 50 out of 150 and schools in the RSD must score a 54 for two consecutive years to be eligible for return. If the AUS bar is raised above 50, schools will be required to score 4 points above the AUS bar.

II. ESTIMATED EFFECT ON REVENUE COLLECTIONS OF STATE OR LOCAL GOVERNMENTAL UNITS (Summary)

There will be no effect on revenue collections of state or local governmental units.

III. ESTIMATED COSTS AND/OR ECONOMIC BENEFITS TO DIRECTLY AFFECTED PERSONS OR NONGOVERNMENTAL GROUPS (Summary)

There will be no costs or economic benefits to directly affected persons or non-governmental groups.

IV. ESTIMATED EFFECT ON COMPETITION AND EMPLOYMENT (Summary)

There will be no effect on competition and employment.

Beth Scioneaux
Deputy Superintendent
1210#041

Evan Brasseaux
Staff Director
Legislative Fiscal Office

NOTICE OF INTENT

Department of Education Board of Regents

Registration and Licensure (LAC 28:IX.103 and 105)

Notice is hereby given in accordance with the provisions of the Administrative Procedure Act, R.S. 49:950 et seq., and through the authority granted in R.S. 17:1808, that the Board of Regents proposes to amend Chapter 1, Sections 103 and 105 to increase the license fee from \$750 to \$1,500 for institutions seeking licensure.

Title 28

EDUCATION

Part IX. Regents

Chapter 1. Rules for Registration and Licensure

§103. Registration and License Applications

A. - B. ...

C. License applications must be accompanied by a nonrefundable license application fee of \$1,500 (approved by Louisiana Legislature Act 278 of the 2012 Regular Legislative Session). The license application fee must be paid by company or institutional check or by money order, and should be made payable to the Louisiana Board of Regents.

AUTHORITY NOTE: Promulgated in accordance with R.S. 17:1808.

HISTORICAL NOTE: Promulgated by the Department of Education, Board of Regents, LR 19:1551 (December 1993), amended LR 21:168 (February 1995), LR 39:

§105. License Fees

A. The license application fee shall be \$1,500 (approved by Louisiana Legislature Act 278 of the 2012 Regular Legislative Session). Those institutions granted a license to operate will be required to pay an additional \$1,500 at the start of the second year of the two-year licensing period. However, the initial license application fee may be reduced to \$200 for those institutions seeking initial licensure in order to allow clinical practicum experiences for fewer than five Louisiana residents enrolled in nursing and other health-related programs only. In order to continue and renew their licenses, those institutions will be required to pay all subsequent fees, including renewal fees. License renewal fees are required during each subsequent two-year licensing period and are nonrefundable.

B. - D. ...

AUTHORITY NOTE: Promulgated in accordance with R.S. 17:1808.

HISTORICAL NOTE: Promulgated by the Department of Education, Board of Regents, LR 19:1551 (December 1993), amended LR 21:168 (February 1995), LR 39:

Family Impact Statement

In accordance with R.S. 17:3141, Title 28 of the Louisiana Revised Statutes, there is hereby submitted a Family Impact Statement on the Rule proposed for adoption, repeal or amendment. All family impact statements shall be kept on file in the state board office which has adopted, amended, or repealed a Rule in accordance with the applicable provisions of the law relating to public records.

1. Will the proposed Rule affect the stability of the family? No.

2. Will the proposed Rule affect the authority and rights of parents regarding the education and supervision of their children? No.

3. Will the proposed Rule affect the functioning of the family? No.

4. Will the proposed Rule affect family earnings and family budget? No.

5. Will the proposed Rule affect the behavior and personal responsibility of children? No.

6. Is the family or a local government able to perform the function as contained in the proposed Rule? Yes.

Public Comments

All interested persons are invited to submit written comments on the proposed regulations. Persons commenting should reference this proposed regulation by Act 129. Such comments must be received no later than November 10, 2012, at 4:30 p.m., and should be sent to Dr. Larry Tremblay, Louisiana State Board of Regents, P.O. Box 3677, Baton Rouge, LA 70821-3677 or fax to (225) 342-9318.

Dr. Larry Tremblay
Deputy Commissioner

FISCAL AND ECONOMIC IMPACT STATEMENT FOR ADMINISTRATIVE RULES RULE TITLE: Registration and Licensure

- I. ESTIMATED IMPLEMENTATION COSTS (SAVINGS) TO STATE OR LOCAL GOVERNMENT UNITS (Summary)
The Board of Regents will incur nominal costs for materials and notification requirements related to publishing the proposed rule change.
- II. ESTIMATED EFFECT ON REVENUE COLLECTIONS OF STATE OR LOCAL GOVERNMENTAL UNITS (Summary)
The proposed rule will increase revenue collections at the Board of Regents by an estimated \$45,000 per year. There are approximately 67 postsecondary institutions currently licensed in Louisiana affected by the proposed fee increase. The Board of Regents estimates that 10 percent, or approximately 7 such institutions will not renew their licenses due to the fee increase. As such, the rule change should increase Board of Regents revenues by approximately \$45,000 per year (60 institutions X \$750 annual licensing fee increase = \$45,000 per year).
- III. ESTIMATED COSTS AND/OR ECONOMIC BENEFITS TO DIRECTLY AFFECTED PERSONS OR NONGOVERNMENTAL GROUPS (Summary)
The proposed rule will require licensed educational institutions wishing to be licensed in the State of Louisiana to pay a fee of \$1,500 instead of \$750. The cost to institutions is estimated to be \$45,000 (60 institutions X \$750). Affected institutions may pass on increased license fees to affected students. Some institutions may choose to cease offering a particular program to students in Louisiana rather than seek licensure.
- IV. ESTIMATED EFFECT ON COMPETITION AND EMPLOYMENT (Summary)
The only potential effect on competition would occur if institutions heretofore licensed in Louisiana decide to discontinue operations in Louisiana. However, this would be minimal since with the increased license fee, Louisiana remains one of the least expensive states in America to operate.

Dr. Larry Tremblay
Associate Commissioner
1210#003

Evan Brasseur
Staff Director
Legislative Fiscal Office

NOTICE OF INTENT

Student Financial Assistance Commission Office of Student Financial Assistance

TOPS GPA Calculation (LAC 28:IV.301)

The Louisiana Student Financial Assistance Commission (LASFAC) announces its intention to amend its Scholarship/Grant rules (R.S. 17:3021-3025, R.S. 3041.10-3041.15, R.S. 17:3042.1, R.S. 17:3048.1, R.S. 17:3048.5 and R.S. 17:3048.6).

This rulemaking amends the definition of *TOPS cumulative high school grade point average* to provide that beginning with 2013-2014 high school graduates, the grade point average will be calculated on the 19 units of courses included in the TOPS core curriculum. (SG13142NI)

Title 28 EDUCATION

Part IV. Student Financial Assistance—Higher Education Scholarship and Grant Programs

Chapter 3. Definitions §301. Definitions

A. Words and terms not otherwise defined in this Chapter shall have the meanings ascribed to such words and terms in this Section. Where the masculine is used in these rules, it includes the feminine, and vice versa; where the singular is used, it includes the plural, and vice versa.

* * *

TOPS Cumulative High School Grade Point Average—

- a. effective for high school graduates beginning with academic year (high school) 2002-2003, the grade point average calculated by LOSFA including only the grades achieved in those courses that were used to satisfy core curriculum requirements. In the event a student has received credit for more than 16.5 hours of courses that are included in the core curriculum, the TOPS cumulative high school grade point average shall be calculated by using the course in each core curriculum category for which the student received the highest grade. For example, if a student has taken more than one advanced mathematics course, the cumulative grade point average shall be determined by using only the course in which the student has received the highest grade;
- b. effective for high school graduates beginning with academic year (high school) 2002-2003, the grade point average for students qualifying for a performance award using a minimum ACT score of 24 and a minimum grade point average of 3.00 must include at least 10 units of honors curriculum courses (see §703.A.5.f.ii);
- c. effective for high school graduates beginning with academic year (high school) 2007-2008, the grade point average shall be calculated on 17.5 hours of units of courses that are used to satisfy the core curriculum;
- d. effective for high school graduates beginning with academic year (high school) 2013-2014, the grade point average shall be calculated on 19.0 hours of units of courses that are used to satisfy the core curriculum;
- e. for those high schools that utilize other than a 4.00 scale, all grade values shall be converted to a 4.00 scale utilizing the following formula:

$$\frac{\text{Quality Points Awarded for the Course}}{\text{Maximum Points Possible for the Course}} = \frac{X (\text{Converted Quality Points})}{4.00 (\text{Maximum Scale})}$$

For example, if a school awards a maximum of 5 points for honors courses, the school must use the following formula to convert an honors course grade of "C":

$$\frac{3.00}{5.00} = \frac{X}{4.00}$$

By cross multiplying,

$$5X = 12; X = 2.40$$

Quality points = Credit for course multiplied by the value assigned to the letter grade.

* * *

AUTHORITY NOTE: Promulgated in accordance with R.S. 17:3021-3025, R.S. 17:3042.1 and R.S. 17:3048.1.

HISTORICAL NOTE: Promulgated by the Student Financial Assistance Commission, Office of Student Financial Assistance, LR 22:338 (May 1996), repromulgated LR 24:632 (April 1998), amended LR 24:1898 (October 1998), LR 24:2237 (December 1998), LR 25:256 (February 1999), LR 25:654 (April 1999), LR 25:1458 and 1460 (August 1999), LR 25:1794 (October 1999), LR 26:65 (January 2000), LR 26:688 (April 2000), LR 26:1262 (June 2000), LR 26:1601 (August 2000), LR 26:1993, 1999 (September 2000), LR 26:2268 (October 2000), LR 26:2752 (December 2000), LR 27:36 (January 2001), LR 27:284 (March 2001), LR 27:1219 (August 2001), LR 27:1840 (November 2001), LR 27:1875 (November 2001), LR 28:45 (January 2002), LR 28:446 (March 2002), LR 28:772 (April 2002), LR 28:2330, 2331 (November 2002), LR 29:555 (April 2003), LR 29:879 (June 2003), LR 30:1159 (June 2004), LR 30:2015 (September 2004), LR 31:36 (January 2005), LR 31:3112 (December 2005), LR 33:86 (January 2007), LR 33:439 (March 2007), LR 33:1339 (July 2007), LR 33:2612 (December 2007), LR 34:234 (February 2008), LR 34:1388 (July 2008), LR 34:1884 (September 2008), LR 35:228 (February 2009), LR 35:1489 (August 2009), LR 35:1490 (August 2009), LR 36:311 (February 2010), LR 36:490 (March 2010), LR 36:2854 (December 2010), LR 37:1561 (June 2011), LR 37:1562 (June 2011), LR 39:

Family Impact Statement

The proposed Rule has no known impact on family formation, stability, or autonomy, as described in LSA-R.S. 49:972.

Small Business Statement

The proposed Rule will have no adverse impact on small businesses as described in R.S. 49:965.2 et seq.

Poverty Statement

The proposed rulemaking will have no impact on poverty as described in R.S. 49:973.

Public Comments

Interested persons may submit written comments on the proposed changes (SG13142NI) until 4:30 p.m., November 10, 2012, to Melanie Amrhein, Executive Director, Office of Student Financial Assistance, P.O. Box 91202, Baton Rouge, LA 70821-9202.

George Badge Eldredge
General Counsel

FISCAL AND ECONOMIC IMPACT STATEMENT FOR ADMINISTRATIVE RULES RULE TITLE: TOPS GPA Calculation

I. ESTIMATED IMPLEMENTATION COSTS (SAVINGS) TO STATE OR LOCAL GOVERNMENTAL UNITS (Summary)

There are no costs or savings to state or local governmental units due to the implementation of the proposed rule.

II. ESTIMATED EFFECT ON REVENUE COLLECTIONS OF STATE OR LOCAL GOVERNMENTAL UNITS (Summary)

There is no impact on state or local governmental revenues.

III. ESTIMATED COSTS AND/OR ECONOMIC BENEFITS TO DIRECTLY AFFECTED PERSONS OR NONGOVERNMENTAL GROUPS (Summary)

There are no costs or economic benefits to directly affected persons or non-governmental groups due to the implementation of this proposed rule.

IV. ESTIMATED EFFECT ON COMPETITION AND EMPLOYMENT (Summary)

Competition and employment will not be affected by the proposed change.

George Badge Eldredge
General Counsel
1210#106

Evan Brasseaux
Staff Director
Legislative Fiscal Office

NOTICE OF INTENT

Office of the Governor Division of Administration Office of Facility Planning and Control

Capital Improvement Projects—Louisiana Building Code (LAC 34:III.131)

In accordance with the provisions of the Administrative Procedure Act (R.S. 49:950 et seq.) and the provisions of R.S. 39:121, the Division of Administration, Facility Planning and Control hereby gives notice of its intent to amend LAC 34:III.131, Louisiana Building Code for state owned buildings. These Rule changes are the result of a review by Facility Planning and Control of the editions of the codes specified by RS 40:1722 and the most recent editions of these codes. This review has led to the determination that new editions of these codes will provide a higher standard than the currently referenced editions. Facility Planning and Control is, therefore, establishing the appropriate editions of these codes as the standards.

Title 34

GOVERNMENT CONTRACTS, PROCUREMENT AND PROPERTY CONTROL

Part III. Facility Planning and Control

Chapter 1. Capital Improvement Projects

Subchapter A. Procedure Manual

§131. Louisiana Building Code

A. - A.4. ...

5. the *NFPA 70: National Electric Code (NEC) 2011 Edition* as published by the National Fire Protection Association.

AUTHORITY NOTE: Promulgated in accordance with R.S. 39:1410.

HISTORICAL NOTE: Promulgated by the Office of the Governor, Division of Administration, Facility Planning and Control, LR 8:473 (September 1982), amended LR 11:849 (September 1985), LR 33:2649 (December 2007), LR 37:3260 (November 2011), LR 39:

Family Impact Statement

1. The Effect of this Rule on the Stability of the Family. This Rule will have no effect on the stability of the family.

2. The Effect of this Rule on the Authority and Rights of Parents Regarding the Education and Supervision of their Children. This Rule will have no effect on the authority and rights of parents regarding the education and supervision of their children.

3. The Effect of this Rule on the Functioning of the Family. This Rule will have no effect on the functioning of the family.

4. The Effect of this Rule on Family Earnings and Family Budget. This Rule will have no effect on family earnings and family budget.

5. The Effect of this Rule on the Behavior and Personal Responsibility of Children. This Rule will have no effect on the behavior and personal responsibility of children.

6. The Effect of this Rule on the Ability of the Family or Local Government to Perform the Function as Contained in the Proposed Rule. This Rule will have no effect on the ability of the family or local government to perform the function as contained in the proposed Rule.

Small Business Statement

The Office of Facility Planning and Control has considered all methods of reducing the impact of the proposed Rule on small business as noted in R.S. 49:965.6. The intent of the proposed Rule is to upgrade the current edition of the National Electric Code established as one of the standards for the Louisiana Building Code. These codes are the basis of safety and mobility of the general public in the design of state owned buildings. It would not be feasible to consider a partial or modified compliance of these building codes specifically for small businesses. Any alternative code standards or exemption of small businesses from these revised building codes would jeopardize the well being of the general public.

Public Comments

Interested persons may submit comments to Mark Bell, Facility Planning and Control, P.O. Box 94095, Baton Rouge, LA 70804-9095. Written comments will be accepted through November 9, 2012.

John L. Davis
Director

FISCAL AND ECONOMIC IMPACT STATEMENT FOR ADMINISTRATIVE RULES RULE TITLE: Capital Improvement Projects—Louisiana Building Code

I. ESTIMATED IMPLEMENTATION COSTS (SAVINGS) TO STATE OR LOCAL GOVERNMENT UNITS (Summary)

There is no anticipated implementation costs as the result of this Rule change. The proposed administrative Rule updates the Louisiana Building Code for state-owned buildings by updating the current edition of the National Electric Code established as standards for the Louisiana Building Code. Due to the new version of building code, the cost per building project will likely increase.

II. ESTIMATED EFFECT ON REVENUE COLLECTIONS OF STATE OR LOCAL GOVERNMENTAL UNITS (Summary)

There is no anticipated direct material effect on governmental revenues as a result of this measure.

III. ESTIMATED COSTS AND/OR ECONOMIC BENEFITS TO DIRECTLY AFFECTED PERSONS OR NONGOVERNMENTAL GROUPS (Summary)

There is no anticipated material impact to directly affected persons or nongovernmental groups as a result of the proposed Rule change. Due to the proposed administrative Rules updating the Louisiana Building Code for state-owned buildings, the cost per project will likely increase. Any project cost increase as a result of the proposed Rule will likely be passed down to the state through the public bid process.

IV. ESTIMATED EFFECT ON COMPETITION AND EMPLOYMENT (Summary)

There is no anticipated direct material effect on competition and employment as a result of the proposed administrative Rules. There will likely be the same number of jobs though some tasks may be slightly different as a result of the proposed administrative Rule.

John L. Davis
Director
1210#108

Evan Brasseaux
Staff Director
Legislative Fiscal Office

NOTICE OF INTENT

Department of Health and Hospitals Bureau of Health Services Financing

Coordinated Care Network
Pharmacy Services Coverage
(LAC 50:I.3503-3509)

The Department of Health and Hospitals, Bureau of Health Services Financing proposes to amend LAC 50:I.3503-3509 in the Medical Assistance Program as authorized by R.S. 36:254 and pursuant to Title XIX of the Social Security Act. This proposed Rule is promulgated in accordance with the provisions of the Administrative Procedure Act, R.S. 49:950 et seq.

The Department of Health and Hospitals, Bureau of Health Services Financing adopted provisions which implemented a coordinated system of care in the Medicaid Program designed to improve performance and health care outcomes through a healthcare delivery system called coordinated care networks, also known as the BAYOU HEALTH Program (*Louisiana Register*, Volume 37, Number 6).

The department now proposes to amend the provisions governing coordinated care networks in order to include pharmacy services as a covered service under the BAYOU HEALTH Program for recipients enrolled in pre-paid health plans.

Title 50

PUBLIC HEALTH—MEDICAL ASSISTANCE

Part I. Administration

Subpart 3. Medicaid Coordinated Care

Chapter 35. Coordinated Care Network Managed Care Organization Model

§3503. Managed Care Organization Model Responsibilities

A. - N. ...

O. A CCN-P shall participate on the department's established committees for administrative simplification and quality improvement, which will include physicians, hospitals, pharmacists, other healthcare providers as appropriate, and at least one member of the Senate and House Health and Welfare Committees or their designees.

P. - P.1.b. ...

Q. The member handbook shall include, but not be limited to:

1. - 5.i. ...

j. how to make, change and cancel medical appointments and the importance of canceling and/or rescheduling rather than being a “no show”;

k. the extent to which and how after-hour services are provided; and

l. information about the CCN’s formulary and/or Preferred Drug List (PDL), including where the member can access the most current information regarding pharmacy benefits.

Q.6. - S.3. ...

AUTHORITY NOTE: Promulgated in accordance with R.S. 36:254 and Title XIX of the Social Security Act.

HISTORICAL NOTE: Promulgated by the Department of Health and Hospitals, Bureau of Health Services Financing, LR 37:1583 (June 2011), amended LR 39:

§3505 Network Access Standards and Guidelines

A. - D. ...

E. Any pharmacy or pharmacist participating in the Medicaid Program may participate as a network provider if licensed and in good standing with the Louisiana State Board of Pharmacy and accepts the terms and conditions of the contract offered to them by the CCN-P.

1. The CCN-P shall not require its members to use mail service pharmacy.

AUTHORITY NOTE: Promulgated in accordance with R.S. 36:254 and Title XIX of the Social Security Act.

HISTORICAL NOTE: Promulgated by the Department of Health and Hospitals, Bureau of Health Services Financing, LR 37:1585 (June 2011), amended LR 39:

§3507. Benefits and Services

A. - A.2. ...

B. The CCN-P:

1. - 5.a. ...

b. no medical service limitation can be more restrictive than those that currently exist under the Title XIX Louisiana Medicaid State Plan;

6. shall provide pregnancy-related services that are necessary for the health of the pregnant woman and fetus, or that have become necessary as a result of being pregnant and includes, but is not limited to prenatal care, delivery, postpartum care, and family planning/interconception care services for pregnant women in accordance with federal regulations; and

7. shall establish a Pharmaceutical and Therapeutics (P and T) Committee or similar committee for the development of its formulary and the PDL.

C. - C.4. ...

D. The following is a summary listing of the core benefits and services that a CCN-P is required to provide:

1. - 16. ...

17. chiropractic services;

18. rehabilitation therapy services (physical, occupational, and speech therapies); and

19. pharmacy services (prescription drugs).

* * *

E. - G.1.f. ...

g. school-based Individualized Education Plan services provided by a school district and billed through the intermediate school district, or school-based services funded with certified public expenditures;

h. home and community-based waiver services;

i. specialized behavioral health; and

j. targeted case management services.

H. - H.5. ...

AUTHORITY NOTE: Promulgated in accordance with R.S. 36:254 and Title XIX of the Social Security Act.

HISTORICAL NOTE: Promulgated by the Department of Health and Hospitals, Bureau of Health Services Financing, LR 37:185 (June 2011), amended LR 39:

§3509. Reimbursement Methodology

A. - A.4.d. ...

5. PMPM payments related to pharmacy services will be adjusted to account for pharmacy rebates.

B. - K.1. ...

L. Network Provider Reimbursement

1. ...

a. The CCN-P shall pay a pharmacy dispensing fee, as defined in the contract, at a rate no less than the minimum specified in the terms of the contract.

2. - 3.a. ...

M. Out-of-Network Provider Reimbursement

1. - 2. ...

3. The CCN-P is not required to reimburse for pharmacy delivered by out-of-network providers. The CCN-P shall maintain a system that denies the claim at the point-of-sale for providers not contracted in the network.

N. - N.2.a. ...

AUTHORITY NOTE: Promulgated in accordance with R.S. 36:254 and Title XIX of the Social Security Act.

HISTORICAL NOTE: Promulgated by the Department of Health and Hospitals, Bureau of Health Services Financing, LR 37:1587 (June 2011), amended LR 39:

Implementation of the provisions of this Rule may be contingent upon the approval of the U.S. Department of Health and Human Services, Centers for Medicare and Medicaid Services (CMS), if it is determined that submission to CMS for review and approval is required.

Family Impact Statement

In compliance with Act 1183 of the 1999 Regular Session of the Louisiana Legislature, the impact of this proposed Rule on the family has been considered. It is anticipated that this proposed Rule will have no impact on family functioning, stability or autonomy as described in R.S. 49:972.

Public Comments

Interested persons may submit written comments to J. Ruth Kennedy, Bureau of Health Services Financing, P.O. Box 91030, Baton Rouge, LA 70821-9030. She is responsible for responding to inquiries regarding this proposed Rule.

Public Hearing

A public hearing on this proposed Rule is scheduled for Wednesday, November 28, 2012 at 9:30 a.m. in Room 118, Bienville Building, 628 North Fourth Street, Baton Rouge, LA. At that time all interested persons will be afforded an opportunity to submit data, views or arguments either orally or in writing. The deadline for receipt of all written comments is 4:30 p.m. on the next business day following the public hearing.

Bruce D. Greenstein
Secretary

**FISCAL AND ECONOMIC IMPACT STATEMENT
FOR ADMINISTRATIVE RULES**

**RULE TITLE: Coordinated Care
Network Pharmacy Services Coverage**

I. ESTIMATED IMPLEMENTATION COSTS (SAVINGS) TO STATE OR LOCAL GOVERNMENT UNITS (Summary)

It is anticipated that the implementation of this proposed rule will result in a net reduction of estimated state programmatic costs of \$5,461,297 for FY 12-13 \$8,708,310 for FY 13-14 and \$8,969,559 for FY 14-15. It is anticipated that \$574 (\$287 SGF and \$287 FED) will be expended in FY 12-13 for the state's administrative expense for promulgation of this proposed rule and the final rule.

II. ESTIMATED EFFECT ON REVENUE COLLECTIONS OF STATE OR LOCAL GOVERNMENTAL UNITS (Summary)

It is anticipated that the implementation of this proposed rule will reduce federal revenue collections by approximately \$10,880,392 for FY 12-13 \$16,540,486 for FY 13-14 and \$17,036,701 for FY 14-15. It is anticipated that \$287 will be expended in FY 12-13 for the federal administrative expenses for promulgation of this proposed rule and the final rule.

III. ESTIMATED COSTS AND/OR ECONOMIC BENEFITS TO DIRECTLY AFFECTED PERSONS OR NONGOVERNMENTAL GROUPS (Summary)

This proposed rule amends the provisions governing coordinated care networks in order to include pharmacy services as a covered service under the BAYOU HEALTH Program for recipients (approx. 470,000) enrolled in pre-paid health plans. It is anticipated that implementation of this proposed rule will reduce expenditures in the Medicaid Program by approximately \$16,342,263 for FY 12-13, \$25,248,796 for FY 13-14 and \$26,006,260 for FY 14-15. To the extent the savings reflected in Act 13 (HB 1) of the 2012 Regular Session are not achieved, the Department may have to make additional cuts to achieve projected savings or realize an additional revenue source to offset the projected savings.

IV. ESTIMATED EFFECT ON COMPETITION AND EMPLOYMENT (Summary)

It is anticipated that the implementation of this proposed rule will not have an effect on competition and employment.

J. Ruth Kennedy
Medicaid Director
1210#052

John D. Carpenter
Legislative Fiscal Officer
Legislative Fiscal Office

NOTICE OF INTENT

**Department of Health and Hospitals
Bureau of Health Services Financing
and
Office of Public Health**

Early and Periodic Screening, Diagnosis and Treatment
Uncompensated Care Payments (LAC 50:XV.Chapter 97)

The Department of Health and Hospitals, Bureau of Health Services Financing proposes to adopt LAC 50:XV.Chapter 97 in the Medical Assistance Program as authorized by R.S. 36:254 and pursuant to Title XIX of the Social Security Act. This proposed Rule is promulgated in accordance with the provisions of the Administrative Procedure Act, R.S. 49:950 et seq.

The Department of Health and Hospitals, Bureau of Health Services Financing and the Office of Public Health

(OPH) promulgated an Emergency Rule which adopted provisions to establish Medicaid payment of uncompensated care costs for services rendered by OPH to Medicaid eligible recipients (*Louisiana Register*, Volume 38, Number 7). This proposed Rule is being promulgated to adopt provisions governing uncompensated care payments to OPH for child health services and children's special health services rendered in the Early and Periodic Screening, Diagnosis and Treatment (EPSDT) Program in order to continue the provisions of the July 1, 2012 Emergency Rule.

Title 50

PUBLIC HEALTH—MEDICAL ASSISTANCE

Part XV. Services for Special Populations

Subpart 5. Early and Periodic Screening, Diagnoses, and Treatment

Chapter 97. Office of Public Health Uncompensated Care Payments

§9701. General Provisions

A. Effective for dates of service on or after July 1, 2012, the department shall provide the Office of Public Health (OPH) with Medicaid payment of their uncompensated care costs for child health services including hearing and speech therapy services, maternity services, and children's special health services rendered to Medicaid recipients.

B. The Office of Public Health shall certify public expenditures to the Medicaid Program in order to secure federal funding for services provided at the cost of OPH.

AUTHORITY NOTE: Promulgated in accordance with R.S. 36:254 and Title XIX of the Social Security Act.

HISTORICAL NOTE: Promulgated by the Department of Health and Hospitals, Bureau of Health Services Financing and the Office of Public Health, LR 39:

§9703. Reimbursement Methodology

A. The OPH will submit an estimate of cost for services provided under this Chapter. The estimated cost will be calculated based on the previous fiscal year's expenditures and reduced by the estimate of payments made for services to OPH under this Chapter, which will be referred to as the net uncompensated care cost. The uncompensated care cost will be reported on a quarterly basis

B. Upon completion of the fiscal year, the Office of Public Health will submit a cost report which will be used as a settlement of cost within one year of the end of the fiscal year.

1. Any adjustments to the net uncompensated care cost for a fiscal year will be reported on the CMS Form 64 as a prior period adjustment in the quarter of settlement.

AUTHORITY NOTE: Promulgated in accordance with R.S. 36:254 and Title XIX of the Social Security Act.

HISTORICAL NOTE: Promulgated by the Department of Health and Hospitals, Bureau of Health Services Financing and the Office of Public Health, LR 39:

Implementation of the provisions of this Rule may be contingent upon the approval of the U.S. Department of Health and Human Services, Centers for Medicare and Medicaid Services (CMS) if it is determined that submission to CMS for review and approval is required.

Family Impact Statement

In compliance with Act 1183 of the 1999 Regular Session of the Louisiana Legislature, the impact of this proposed Rule on the family has been considered. It is anticipated that

this proposed Rule will have a no impact on family functioning, stability and autonomy as described in R.S. 49:972.

Public Comments

Interested persons may submit written comments to J. Ruth Kennedy, Bureau of Health Services Financing, P.O. Box 91030, Baton Rouge, LA 70821-9030. She is responsible for responding to inquiries regarding this proposed Rule.

Public Hearing

A public hearing on this proposed Rule is scheduled for Wednesday, November 28, 2012 at 9:30 a.m. in Room 118, Bienville Building, 628 North Fourth Street, Baton Rouge, LA. At that time all interested persons will be afforded an opportunity to submit data, views or arguments either orally or in writing. The deadline for receipt of all written comments is 4:30 p.m. on the next business day following the public hearing.

Bruce D. Greenstein
Secretary

FISCAL AND ECONOMIC IMPACT STATEMENT FOR ADMINISTRATIVE RULES

RULE TITLE: Early and Periodic Screening, Diagnosis and Treatment—Uncompensated Care Payments

I. ESTIMATED IMPLEMENTATION COSTS (SAVINGS) TO STATE OR LOCAL GOVERNMENT UNITS (Summary)

It is anticipated that the implementation of this proposed rule will result in estimated state programmatic costs of \$1,477,249 for FY 12-13, \$1,570,108 for FY 13-14 and \$1,617,212 for FY 14-15; however, the state match shall be met through a certified public expenditure financing arrangement whereby the Office of Public Health (OPH) shall transfer to the Medicaid Program funds to secure federal match to make supplemental Medicaid payments to OPH for uncompensated care costs. It is anticipated that \$328 (\$164 SGF and \$164 FED) will be expended in FY 12-13 for the state's administrative expense for promulgation of this proposed rule and the final rule.

II. ESTIMATED EFFECT ON REVENUE COLLECTIONS OF STATE OR LOCAL GOVERNMENTAL UNITS (Summary)

It is anticipated that the implementation of this proposed rule will increase federal revenue collections by approximately \$2,942,844 for FY 12-13, \$2,982,250 for FY 13-14 and \$3,071,717 for FY 14-15. It is anticipated that \$164 will be expended in FY 12-13 for the federal administrative expenses for promulgation of this proposed rule and the final rule.

III. ESTIMATED COSTS AND/OR ECONOMIC BENEFITS TO DIRECTLY AFFECTED PERSONS OR NONGOVERNMENTAL GROUPS (Summary)

This proposed Rule, which continues the provisions of the July 1, 2012 emergency rule, is being promulgated to amend the provisions governing child health and children's special health services rendered by the Office of Public Health in order to reimburse supplemental Medicaid payments for their uncompensated care costs for services provided in the Early and Periodic Screening, Diagnosis and Treatment Program. It is anticipated that implementation of this proposed rule will increase programmatic expenditures in the Medicaid Program by approximately \$4,419,765 for FY 12-13, \$4,552,358 for FY 13-14 and \$4,688,929 for FY 14-15.

IV. ESTIMATED EFFECT ON COMPETITION AND EMPLOYMENT (Summary)

It is anticipated that the implementation of this proposed rule will not have an effect on competition and employment.

J. Ruth Kennedy
Medicaid Director
1210#053

John D. Carpenter
Legislative Fiscal Officer
Legislative Fiscal Office

NOTICE OF INTENT

Department of Health and Hospitals Bureau of Health Services Financing

Family Planning Clinics
Reimbursement Methodology
Office of Public Health Uncompensated Care Payments
(LAC 50:XI.3501)

The Department of Health and Hospitals, Bureau of Health Services Financing proposes to amend LAC 50:XI.3501 in the Medical Assistance Program as authorized by R.S. 36:254 and pursuant to Title XIX of the Social Security Act. This proposed Rule is promulgated in accordance with the provisions of the Administrative Procedure Act, R.S. 49:950, et seq.

As a result of a budgetary shortfall in state fiscal year 2011, the Department of Health and Hospitals, Bureau of Health Services Financing amended the provisions governing the reimbursement methodology for family planning clinics to reduce the reimbursement rates (*Louisiana Register*, Volume 37, Number 6).

The Department of Health and Hospitals, Bureau of Health Services Financing and the Office of Public Health (OPH) promulgated an Emergency Rule which adopted provisions to establish Medicaid payment of uncompensated care costs for services rendered by OPH to Medicaid eligible recipients (*Louisiana Register*, Volume 38, Number 7). This proposed Rule is being promulgated to amend the provisions governing the reimbursement methodology for family planning clinics in order to continue the provisions of the July 1, 2012 Emergency Rule governing uncompensated care payments to OPH.

Title 50

PUBLIC HEALTH—MEDICAL ASSISTANCE

Part XI. Clinic Services

Subpart 5. Family Planning

Chapter 35. Reimbursement

§3501. Reimbursement Methodology

A. - C. ...

D. Office of Public Health Uncompensated Care Payments

1. Effective for dates of service on or after July 1, 2012, the department shall provide the Office of Public Health (OPH) with Medicaid payment of their uncompensated care costs for services rendered to Medicaid recipients. The Office of Public Health shall certify public expenditures to the Medicaid Program in order to secure federal funding for services provided at the cost of OPH.

2. The OPH will submit an estimate of cost for services provided under this Chapter.

a. The estimated cost will be calculated based on the previous fiscal year's expenditures and reduced by the estimate of payments made for services to OPH under this Chapter, which will be referred to as the net uncompensated care cost. The uncompensated care cost will be reported on a quarterly basis

3. Upon completion of the fiscal year, the Office of Public Health will submit a cost report which will be used as a settlement of cost within one year of the end of the fiscal year.

a. Any adjustments to the net uncompensated care cost for a fiscal year will be reported on the CMS Form 64 as a prior period adjustment in the quarter of settlement.

AUTHORITY NOTE: Promulgated in accordance with R.S. 36:254 and Title XIX of the Social Security Act.

HISTORICAL NOTE: Promulgated by the Department of Health and Hospitals, Office of the Secretary, Bureau of Health Services Financing, LR 30:1022 (May 2004), amended by the Department of Health and Hospitals, Bureau of Health Services Financing, LR 37:1600 (June 2011), LR 39:

Implementation of the provisions of this Rule may be contingent upon the approval of the U.S. Department of Health and Human Services, Centers for Medicare and Medicaid Services (CMS), if it is determined that submission to CMS for review and approval is required.

Family Impact Statement

In compliance with Act 1183 of the 1999 Regular Session of the Louisiana Legislature, the impact of this proposed Rule on the family has been considered. It is anticipated that this proposed Rule will have no impact on family functioning, stability or autonomy as described in R.S. 49:972.

Public Comments

Interested persons may submit written comments to J. Ruth Kennedy, Bureau of Health Services Financing, P.O. Box 91030, Baton Rouge, LA 70821—9030. She is responsible for responding to inquiries regarding this proposed Rule.

Public Hearing

A public hearing on this proposed Rule is scheduled for Wednesday, November 28, 2012 at 9:30 a.m. in Room 118, Bienville Building, 628 North Fourth Street, Baton Rouge, LA. At that time all interested persons will be afforded an opportunity to submit data, views or arguments either orally or in writing. The deadline for receipt of all written comments is 4:30 p.m. on the next business day following the public hearing.

Bruce D. Greenstein
Secretary

FISCAL AND ECONOMIC IMPACT STATEMENT FOR ADMINISTRATIVE RULES RULE TITLE: Family Planning Clinics Reimbursement Methodology Office of Public Health Uncompensated Care Payments

I. ESTIMATED IMPLEMENTATION COSTS (SAVINGS) TO STATE OR LOCAL GOVERNMENT UNITS (Summary)

It is anticipated that the implementation of this proposed rule will result in estimated state programmatic costs of \$138,160 for FY 12-13, \$146,686 for FY 13-14 and \$151,087 for FY 14-15; however, the state match shall be met through a

certified public expenditure financing arrangement whereby the Office of Public Health (OPH) shall transfer to the Medicaid Program funds to secure federal match to make supplemental Medicaid payments to OPH for uncompensated care costs. It is anticipated that \$328 (\$164 SGF and \$164 FED) will be expended in FY 12-13 for the state's administrative expense for promulgation of this proposed rule and the final rule.

II. ESTIMATED EFFECT ON REVENUE COLLECTIONS OF STATE OR LOCAL GOVERNMENTAL UNITS (Summary)

It is anticipated that the implementation of this proposed rule will increase federal revenue collections by approximately \$275,082 for FY 12-13, \$278,615 for FY 13-14 and \$286,973 for FY 14-15. It is anticipated that \$164 will be expended in FY 12-13 for the federal administrative expenses for promulgation of this proposed rule and the final rule

III. ESTIMATED COSTS AND/OR ECONOMIC BENEFITS TO DIRECTLY AFFECTED PERSONS OR NONGOVERNMENTAL GROUPS (Summary)

This proposed Rule, which continues the provisions of the July 1, 2012 emergency rule, is being promulgated to amend the provisions governing the reimbursement methodology for family planning clinics in order to reimburse supplemental Medicaid payments to OPH for their uncompensated care costs for family planning clinic services rendered to Medicaid recipients. It is anticipated that implementation of this proposed rule will increase programmatic expenditures in the Medicaid Program by approximately \$412,914 for FY 12-13, \$425,301 for FY 13-14 and \$438,060 for FY 14-15.

IV. ESTIMATED EFFECT ON COMPETITION AND EMPLOYMENT (Summary)

It is anticipated that the implementation of this proposed rule will not have an effect on competition and employment.

J. Ruth Kennedy
Medicaid Director
1210#054

John D. Carpenter
Legislative Fiscal Officer
Legislative Fiscal Office

NOTICE OF INTENT

Department of Health and Hospitals Bureau of Health Services Financing

Inpatient Hospital Services—Distinct Part Psychiatric Units
Reimbursement Methodology
(LAC 50:V.915 and 959)

The Department of Health and Hospitals, Bureau of Health Services Financing proposes to amend LAC 50:V.915 and §959 in the Medical Assistance Program as authorized by R.S. 36:254 and pursuant to Title XIX of the Social Security Act. This proposed Rule is promulgated in accordance with the provisions of the Administrative Procedure Act, R.S. 49:950, et seq.

In compliance with Act 18 of the 2007 Regular Session of the Louisiana Legislature, the Department of Health and Hospitals, Office of the Secretary, Bureau of Health Services Financing amended the provisions governing inpatient psychiatric services to allow acute care hospitals that enter into an agreement with the Office of Mental Health [currently the Office of Behavioral Health] to expand their distinct part psychiatric unit beds and receive Medicaid reimbursement for the patients who occupy the additional beds (*Louisiana Register*, Volume 34, Number 9).

The department promulgated an Emergency Rule which amended the provisions governing the reimbursement methodology for inpatient psychiatric hospital services

rendered by distinct part psychiatric units of acute care hospitals that enter into a cooperative endeavor agreement (CEA) with the Department of Health and Hospitals, Office of Behavioral Health (*Louisiana Register*, Volume 38, Number 2). The department promulgated an Emergency Rule which amended the February 10, 2012 Emergency Rule to clarify the provisions governing qualifying hospitals (*Louisiana Register*, Volume 38, Number 5). The department promulgated an Emergency Rule which amended the May 20, 2012 Emergency Rule to revise the formatting of the provisions governing qualifying hospitals to ensure that they are promulgated in a clear and concise format (*Louisiana Register*, Volume 38, Number 8). This proposed Rule is being promulgated to continue the provisions of the August 20, 2012 Emergency Rule.

Title 50

PUBLIC HEALTH—MEDICAL ASSISTANCE

Part V. Medical Assistance Program—Hospital Services

Subpart 1. Inpatient Hospitals

Chapter 9. Non-Rural, Non-State Hospitals

Subchapter A. General Provisions

§915. Distinct Part Psychiatric Units

A. ...

1. - 1.b. Repealed.

B. Effective for dates of service on or after February 10, 2012, a Medicaid enrolled non-state acute care hospital that enters into a Cooperative Endeavor Agreement (CEA) with the Department of Health and Hospitals, Office of Behavioral Health to provide inpatient psychiatric hospital services to Medicaid and uninsured patients, and which also assumes the operation and management of a state-owned and formerly state-operated hospital distinct part psychiatric unit, may make a one-time increase in its number of beds with a one-time opening of a new distinct part psychiatric unit.

1. This expansion or opening of a new unit will not be recognized, for Medicare purposes, until the beginning of the next cost reporting period. At the next cost reporting period, the hospital must meet the Medicare Prospective Payment System (PPS) exemption criteria and enroll as a Medicare PPS excluded distinct part psychiatric unit.

2. At the time of any expansion or opening of a new distinct part psychiatric unit, the provider must provide a written attestation that they meet all Medicare PPS rate exemption criteria.

3. Admissions to this expanded or new distinct part psychiatric unit may not be based on payer source.

C. Changes in the Status of Hospital Units. The status of each hospital unit is determined at the beginning of each cost reporting period and is effective for the entire cost reporting period. Any changes in the status of a unit are made only at the start of a cost reporting period.

1. Repealed.

AUTHORITY NOTE: Promulgated in accordance with R.S. 36:254 and Title XIX of the Social Security Act.

HISTORICAL NOTE: Promulgated by the Department of Health and Hospitals, Office of the Secretary, Bureau of Health Services Financing, LR 20:49 (January 1994), amended LR 34:1913 (September 2008), amended by the Department of Health and Hospitals, Bureau of Health Services Financing, LR 39:

Subchapter B. Reimbursement Methodology

§959. Inpatient Psychiatric Hospital Services

A. - K.2.b. ...

L. Effective for dates of service on or after February 10, 2012, a Medicaid enrolled non-state acute care hospital that enters into a Cooperative Endeavor Agreement (CEA) with the Department of Health and Hospitals, Office of Behavioral Health to provide inpatient psychiatric hospital services to Medicaid and uninsured patients, and which also assumes the operation and management of formerly state-owned and operated psychiatric hospitals/visits, shall be paid a per diem rate of \$581.11 per day.

AUTHORITY NOTE: Promulgated in accordance with R.S. 36:254 and Title XIX of the Social Security Act.

HISTORICAL NOTE: Promulgated by the Department of Health and Hospitals, Office of the Secretary, Bureau of Health Services Financing, LR 34:876 (May 2008), amended by the Department of Health and Hospitals, Bureau of Health Services Financing, LR 35:1895 (September 2009), repromulgated LR 35:2183 (October 2009), amended LR 36:1554 (July 2010), LR 36:2562 (November, 2010), LR 37:2162 (July 2011), LR 39:

Implementation of the provisions of this Rule may be contingent upon the approval of the U.S. Department of Health and Human Services, Centers for Medicare and Medicaid Services (CMS), if it is determined that submission to CMS for review and approval is required.

Family Impact Statement

In compliance with Act 1183 of the 1999 Regular Session of the Louisiana Legislature, the impact of this proposed Rule on the family has been considered. It is anticipated that this proposed Rule will have no impact on family functioning, stability or autonomy as described in R.S. 49:972.

Public Comments

Interested persons may submit written comments to J. Ruth Kennedy, Bureau of Health Services Financing, P.O. Box 91030, Baton Rouge, LA 70821-9030. She is responsible for responding to inquiries regarding this proposed Rule.

Public Hearing

A public hearing on this proposed Rule is scheduled for Wednesday, November 28, 2012 at 9:30 a.m. in Room 118, Bienville Building, 628 North Fourth Street, Baton Rouge, LA. At that time all interested persons will be afforded an opportunity to submit data, views or arguments either orally or in writing. The deadline for receipt of all written comments is 4:30 p.m. on the next business day following the public hearing.

Bruce D. Greenstein
Secretary

FISCAL AND ECONOMIC IMPACT STATEMENT FOR ADMINISTRATIVE RULES

RULE TITLE: Inpatient Hospital Services Distinct Part Psychiatric Units Reimbursement Methodology

I. ESTIMATED IMPLEMENTATION COSTS (SAVINGS) TO STATE OR LOCAL GOVERNMENT UNITS (Summary)

It is anticipated that the implementation of this proposed rule will result in estimated state general fund programmatic

costs of \$69,776 for FY 12-13 \$73,908 for FY 13-14 and \$76,126 for FY 14-15; however, the costs will be directly offset by an anticipated savings in state general funds of approximately \$504,523 for FY 12-13, \$536,296 for FY 13-14 and \$552,386 for FY 14-15 in disproportionate share hospital payments. It is anticipated that \$492 (\$246 SGF and \$246 FED) will be expended in FY 12-13 for the state's administrative expense for promulgation of this proposed rule and the final rule.

II. ESTIMATED EFFECT ON REVENUE COLLECTIONS OF STATE OR LOCAL GOVERNMENTAL UNITS (Summary)

It is anticipated that the implementation of this proposed rule will increase federal revenue collections by approximately \$138,764 for FY 12-13 \$140,381 for FY 13-14 and \$144,592 for FY 14-15. It is anticipated that \$246 will be expended in FY 12-13 for the federal administrative expenses for promulgation of this proposed rule and the final rule.

III. ESTIMATED COSTS AND/OR ECONOMIC BENEFITS TO DIRECTLY AFFECTED PERSONS OR NONGOVERNMENTAL GROUPS (Summary)

This proposed Rule, which continues the provisions of the August 20, 2012 Emergency Rule, amends the provisions governing the reimbursement methodology for inpatient hospital services rendered by a distinct part psychiatric unit of an acute care hospital that enters into a cooperative endeavor agreement with the DHH, Office of Behavioral Health (1 qualifying hospital). It is anticipated that implementation of this proposed rule will increase programmatic expenditures in the Medicaid Program by approximately \$208,048 for FY 12-13, \$214,289 for FY 13-14 and \$220,718 for FY 14-15.

IV. ESTIMATED EFFECT ON COMPETITION AND EMPLOYMENT (Summary)

It is anticipated that the implementation of this proposed rule will not have an effect on competition and employment.

J. Ruth Kennedy
Medicaid Director
1210#055

John D. Carpenter
Legislative Fiscal Officer
Legislative Fiscal Office

NOTICE OF INTENT

**Department of Health and Hospitals
Bureau of Health Services Financing**

Laboratory Services
Office of Public Health Uncompensated Care Payments
(LAC 50:XIX.4329)

The Department of Health and Hospitals, Bureau of Health Services Financing proposes to amend LAC 50:XIX.4329 in the Medical Assistance Program as authorized by R.S. 36:254 and pursuant to Title XIX of the Social Security Act. This proposed Rule is promulgated in accordance with the provisions of the Administrative Procedure Act, R.S. 49:950, et seq.

As a result of a budgetary shortfall in state fiscal year 2011, the Department of Health and Hospitals, Bureau of Health Services Financing amended the provisions governing the reimbursement methodology for laboratory and radiology services to reduce the reimbursement rates (*Louisiana Register*, Volume 37, Number 10).

The Department of Health and Hospitals, Bureau of Health Services Financing and the Office of Public Health (OPH) promulgated an Emergency Rule which adopted provisions to establish Medicaid payment of uncompensated

care costs for services rendered by OPH to Medicaid eligible recipients (*Louisiana Register*, Volume 38, Number 7). This proposed Rule is being promulgated to amend the provisions governing the reimbursement methodology for laboratory services in order to continue the provisions of the July 1, 2012 Emergency Rule governing uncompensated care payments to OPH.

Title 50

PUBLIC HEALTH—MEDICAL ASSISTANCE

Part XIX. Other Services

Subpart 3. Laboratory and Radiology

Chapter 43. Billing and Reimbursement

§4329. Laboratory Services (Physicians and Independent Laboratories)

A. - K. ...

L. Office of Public Health Uncompensated Care Payments

1. Effective for dates of service on or after July 1, 2012, the department shall provide the Office of Public Health (OPH) with Medicaid payment of their uncompensated care costs for services rendered to Medicaid recipients. The Office of Public Health shall certify public expenditures to the Medicaid Program in order to secure federal funding for services provided at the cost of OPH.

2. The OPH will submit an estimate of cost for services provided under this Chapter.

a. The estimated cost will be calculated based on the previous fiscal year's expenditures and reduced by the estimate of payments made for services to OPH under this Chapter, which will be referred to as the net uncompensated care cost. The uncompensated care cost will be reported on a quarterly basis

3. Upon completion of the fiscal year, the Office of Public Health will submit a cost report which will be used as a settlement of cost within one year of the end of the fiscal year.

a. Any adjustments to the net uncompensated care cost for a fiscal year will be reported on the CMS Form 64 as a prior period adjustment in the quarter of settlement.

AUTHORITY NOTE: Promulgated in accordance with R.S. 46:153, R.S. 49:1008(A), P.L. 98-369, and Title XIX of the Social Security Act.

HISTORICAL NOTE: Promulgated by the Department of Health and Hospitals, Office of the Secretary, Bureau of Health Services Financing, LR 28:1025 (May 2002), amended by the Department of Health and Hospitals, Bureau of Health Services Financing, LR 35:1897 (September 2009), LR 36:1248 (June 2010), LR 36:2563 (November 2010), LR 37:3028 (October 2011), LR 39:

Implementation of the provisions of this Rule may be contingent upon the approval of the U.S. Department of Health and Human Services, Centers for Medicare and Medicaid Services (CMS), if it is determined that submission to CMS for review and approval is required.

Family Impact Statement

In compliance with Act 1183 of the 1999 Regular Session of the Louisiana Legislature, the impact of this proposed Rule on the family has been considered. It is anticipated that this proposed Rule will have no impact on family functioning, stability or autonomy as described in R.S. 49:972.

Public Comments

Interested persons may submit written comments to J. Ruth Kennedy, Bureau of Health Services Financing, P.O. Box 91030, Baton Rouge, LA 70821-9030. She is responsible for responding to inquiries regarding this proposed Rule.

Public Hearing

A public hearing on this proposed Rule is scheduled for Wednesday, November 28, 2012 at 9:30 a.m. in Room 118, Bienville Building, 628 North Fourth Street, Baton Rouge, LA. At that time all interested persons will be afforded an opportunity to submit data, views or arguments either orally or in writing. The deadline for receipt of all written comments is 4:30 p.m. on the next business day following the public hearing.

Bruce D. Greenstein
Secretary

FISCAL AND ECONOMIC IMPACT STATEMENT FOR ADMINISTRATIVE RULES

RULE TITLE: Laboratory Services Office of Public Health Uncompensated Care Payments

I. ESTIMATED IMPLEMENTATION COSTS (SAVINGS) TO STATE OR LOCAL GOVERNMENT UNITS (Summary)

It is anticipated that the implementation of this proposed rule will result in estimated state programmatic costs of \$702,807 for FY 12-13, \$746,893 for FY 13-14 and \$769,300 for FY 14-15; however, the state match shall be met through a certified public expenditure financing arrangement whereby the Office of Public Health (OPH) shall transfer to the Medicaid Program funds to secure federal match to make supplemental Medicaid payments to OPH for uncompensated care costs. It is anticipated that \$328 (\$164 SGF and \$164 FED) will be expended in FY 12-13 for the state's administrative expense for promulgation of this proposed rule and the final rule.

II. ESTIMATED EFFECT ON REVENUE COLLECTIONS OF STATE OR LOCAL GOVERNMENTAL UNITS (Summary)

It is anticipated that the implementation of this proposed rule will increase federal revenue collections by approximately \$1,399,983 for FY 12-13, \$1,418,643 for FY 13-14 and \$1,461,202 for FY 14-15. It is anticipated that \$164 will be expended in FY 12-13 for the federal administrative expenses for promulgation of this proposed rule and the final rule.

III. ESTIMATED COSTS AND/OR ECONOMIC BENEFITS TO DIRECTLY AFFECTED PERSONS OR NONGOVERNMENTAL GROUPS (Summary)

This proposed Rule, which continues the provisions of the July 1, 2012 emergency rule, is being promulgated to amend the provisions governing the reimbursement methodology for laboratory services rendered by OPH in order to reimburse supplemental Medicaid payments for their uncompensated care costs for services rendered to Medicaid recipients. It is anticipated that implementation of this proposed rule will increase programmatic expenditures in the Medicaid Program by approximately \$2,102,462 for FY 12-13, \$2,165,536 for FY 13-14 and \$2,230,502 for FY 14-15.

IV. ESTIMATED EFFECT ON COMPETITION AND EMPLOYMENT (Summary)

It is anticipated that the implementation of this proposed rule will not have an effect on competition and employment.

J. Ruth Kennedy
Medicaid Director
1210#056

John D. Carpenter
Legislative Fiscal Officer
Legislative Fiscal Office

NOTICE OF INTENT

Department of Health and Hospitals Bureau of Health Services Financing

Pharmacy Benefits Management Program
Methods of Payment (LAC 50:XXIX.105 and Chapter 9)

The Department of Health and Hospitals, Bureau of Health Services Financing proposes to amend LAC 50:XXIX.105 and Chapter 9 in the Medical Assistance Program as authorized by R.S. 36:254 and pursuant to Title XIX of the Social Security Act. This proposed Rule is promulgated in accordance with the provisions of the Administrative Procedure Act, R.S. 49:950 et seq.

The Department of Health and Hospitals, Bureau of Health Services Financing provides coverage and reimbursement for prescription drugs to Medicaid eligible recipients enrolled in the Medicaid Program. Act 10 of the 2009 Regular Session of the Louisiana Legislature provided that the department may redefine the reimbursement methodology for multiple source drugs in establishing the state maximum allowable cost (MAC) in order to control expenditures to the level of appropriations for the Medicaid Program. In accordance with the provisions of Act 10, the department promulgated an Emergency Rule to redefine the Louisiana maximum allowable cost (LMAC) (*Louisiana Register*, Volume 36, Number 1). In addition, the dispensing fee was increased for drugs with an LMAC.

The department subsequently determined that it was necessary to repeal the January 1, 2010 Emergency Rule in its entirety and amend the provisions governing the methods of payment for prescription drugs to redefine the LMAC (*Louisiana Register*, Volume 36, Number 2). The department promulgated an Emergency Rule to amend the February 1, 2010 Emergency Rule to revise the provisions governing the methods of payment for prescription drugs to further redefine the LMAC and increase the dispensing fee (*Louisiana Register*, Volume 36, Number 3). The department determined that it was necessary to repeal the March 1, 2010 Emergency Rule in its entirety and promulgated an Emergency Rule to amend the provisions governing the methods of payment for prescription drugs to revise the LMAC provisions (*Louisiana Register*, Volume 36, Number 3). The department determined that it was necessary to repeal the March 20, 2010 Emergency Rule in its entirety in order to revise the provisions governing the methods of payment for prescription drugs and the dispensing fee (*Louisiana Register*, Volume 38, Number 9). This proposed Rule is being promulgated to continue the provisions of the September 5, 2012 Emergency Rule.

Title 50

PUBLIC HEALTH—MEDICAL ASSISTANCE

Part XXIX. Pharmacy

Chapter 1. General Provisions

§105. Medicaid Pharmacy Benefits Management System Point of Sale—Prospective Drug Utilization Program

A. - B. ...

C. Formulary Management. The formulary is managed through the use of Federal Upper Limits (FUL). Federal Upper Limits provide for dispensing of multiple source drugs at established limitations unless the prescribing

physician specifies that the brand product is medically necessary for a patient. Establishment of co-payments also provides for formulary management. The Medicaid Program has established a broad formulary with limited exceptions.

D. Reimbursement Management. The cost of pharmaceutical care is managed through Estimated Acquisition Cost (EAC) of drug ingredient costs through Average Acquisition Cost (AAC) or through Wholesale Acquisition Cost (WAC) when no AAC is assigned; and compliance with Federal Upper Limits regulations, and the establishment of the dispensing fee, drug rebates, and copayments.

E. - H. ...

I. POS/PRO-DUR Requirements Provider Participation

1. - 5. ...

6. Pharmacy providers and physicians may obtain assistance with clinical questions from the University of Louisiana at Monroe, School of Pharmacy.

I.7. - L. ...

AUTHORITY NOTE: Promulgated in accordance with R.S. 46:153, Title XIX of the Social Security Act, and the 1995-96 General Appropriate Act.

HISTORICAL NOTE: Promulgated by the Department of Health and Hospitals, Office of the Secretary, Bureau of Health Services Financing, LR 32:1053 (June 2006), amended by the Department of Health and Hospitals, Bureau of Health Services Financing, LR 39:

Chapter 9. Methods of Payment

Subchapter A. General Provisions

§901. Definitions

Average Acquisition Cost (AAC)—the average of net payments that pharmacists made to purchase a drug product, after taking into account such items as purchasing allowances, discounts, and rebates as determined through the collection and review of pharmacy invoices and other information deemed necessary by the Medicaid Program, and in accordance with applicable state and Federal law.

Average Wholesale Price—Repealed.

Dispensing Fee—the fee paid by the Medicaid Program to reimburse for the professional services provided by a pharmacist when dispensing a prescription, including the provider fee assessed for each prescription filled in the state of Louisiana or shipped into the state of Louisiana per legislative mandate.

Single Source Drug—a drug mandated or sold by one manufacturer or labeler.

Usual and Customary Charge—a pharmacy's charge to the general public that reflects all advertised savings, discounts, special promotions, or other programs, including membership-based discounts initiated to reduce prices for product costs available to the general public, a special population, or an inclusive category of customers.

Wholesale Acquisition Cost (WAC)—the manufacturer's published catalog price for a drug product to wholesalers as reported to Medicaid by one or more national compendia on a weekly basis.

AUTHORITY NOTE: Promulgated in accordance with R.S. 36:254 and Title XIX of the Social Security Act.

HISTORICAL NOTE: Promulgated by the Department of Health and Hospitals, Office of the Secretary, Bureau of Health Services Financing, LR 32:1061 (June 2006), amended LR 34:87

(January 2008), amended by the Department of Health and Hospitals, Bureau of Health Services Financing, LR 36:1558 (July 2010), LR 39:

Subchapter B. Dispensing Fee

§915. General Provisions

A. The dispensing fee shall be set by the Department and reviewed periodically for reasonableness and, when deemed appropriate by the Medicaid Program, may be adjusted considering such factors as fee studies or surveys.

Adjustment Factors—

a. - d. Repealed.

Base Rate—Repealed.

Base Rate Components—Repealed.

Table. Repealed.

a. - d. Repealed.

Maximum Allowable Overhead Cost—Repealed.

Overhead Year—Repealed.

B. Provider participation in the Louisiana Dispensing Fee Survey shall be mandatory. Failure to cooperate in the Louisiana Dispensing Fee Survey by a provider shall result in removal from participation as a provider of pharmacy services in the Medicaid Program. Any provider removed from participation shall not be allowed to re-enroll until a dispensing fee survey document is properly completed and submitted to the bureau.

AUTHORITY NOTE: Promulgated in accordance with R.S. 46:153 and Title XIX of the Social Security Act.

HISTORICAL NOTE: Promulgated by the Department of Health and Hospitals, Bureau of Health Services Financing, LR 36:1558 (July 2010), amended LR 39:

§917. Maximum Allowable Overhead Cost Calculation

Repealed.

AUTHORITY NOTE: Promulgated in accordance with R.S. 46:153 and Title XIX of the Social Security Act.

HISTORICAL NOTE: Promulgated by the Department of Health and Hospitals, Bureau of Health Services Financing, LR 36:1559 (July 2010), repealed LR 39:

§919. Parameters and Limitations

Repealed.

AUTHORITY NOTE: Promulgated in accordance with R.S. 46:153 and Title XIX of the Social Security Act.

HISTORICAL NOTE: Promulgated by the Department of Health and Hospitals, Bureau of Health Services Financing, LR 36:1560 (July 2010), repealed LR 39:

§921. Interim Adjustment to Overhead Cost

Repealed.

AUTHORITY NOTE: Promulgated in accordance with R.S. 46:153 and Title XIX of the Social Security Act.

HISTORICAL NOTE: Promulgated by the Department of Health and Hospitals, Bureau of Health Services Financing, LR 36:1560 (July 2010), repealed LR 39:

§923. Cost Survey

Repealed.

AUTHORITY NOTE: Promulgated in accordance with R.S. 46:153 and Title XIX of the Social Security Act.

HISTORICAL NOTE: Promulgated by the Department of Health and Hospitals, Bureau of Health Services Financing, LR 36:1560 (July 2010), repealed LR 39:

§925. Dispensing Fee

Repealed.

AUTHORITY NOTE: Promulgated in accordance with R.S. 46:153 and Title XIX of the Social Security Act.

HISTORICAL NOTE: Promulgated by the Department of Health and Hospitals, Office of the Secretary, Bureau of Health Services Financing, LR 32:1064 (June 2006), amended LR 34:88

(January 2008), amended by the Department of Health and Hospitals, Bureau of Health Services Financing, LR 36:1561 (July 2010), repealed LR 39:

Subchapter C. Estimated Acquisition Cost

§935. Estimated Acquisition Cost Formula

A. *Estimated Acquisition Cost (EAC)* is the average acquisition cost of the drug dispensed. If there is not an AAC available, the EAC is equal to the wholesale acquisition cost, as reported in the drug pricing compendia utilized by the department's fiscal intermediary.

B. - B.4c. Repealed.

AUTHORITY NOTE: Promulgated in accordance with R.S. 36:254 and Title XIX of the Social Security Act.

HISTORICAL NOTE: Promulgated by the Department of Health and Hospitals, Office of the Secretary, Bureau of Health Services Financing, LR 32:1064 (June 2006), amended LR 34:88 (January 2008), amended by the Department of Health and Hospitals, Bureau of Health Services Financing, LR 36:1561 (July 2010), amended LR 39:

Subchapter D. Maximum Allowable Costs

§945. Reimbursement Methodology

A. Maximum Pharmaceutical Price Schedule

1. ...

2. Repealed.

B. Payment will be made for medications in accordance with the payment procedures for any eligible person who has identified himself to the provider by presenting his identification card which shows his eligibility. The department advises participating pharmacists regarding payable medication.

C. - F. ...

AUTHORITY NOTE: Promulgated in accordance with R.S. 36:254 and Title XIX of the Social Security Act.

HISTORICAL NOTE: Promulgated by the Department of Health and Hospitals, Office of the Secretary, Bureau of Health Services Financing, LR 32:1064 (June 2006), amended LR 34:88 (January 2008), amended by the Department of Health and Hospitals, Bureau of Health Services Financing, LR 36:1561 (July 2010), amended LR 39:

§949. Cost Limits

A. - A.3.c. ...

B. The department shall make payments for single source drugs based on the lower of:

1. Estimated acquisition cost (EAC) plus the dispensing fee; or

2. the provider's usual and customary charges to the general public not to exceed the department's "Maximum Pharmaceutical Price Schedule." *General public* is defined here as all other non-Medicaid prescriptions including:

- a. third party insurance;
- b. pharmacy benefit management; or
- c. cash.

3. Repealed.

C. The department shall make payments for multiple source drugs other than drugs subject to "physician certifications" based on the lower of:

1. Estimated Acquisition Cost plus the dispensing fee;

2. Federal Upper Limits plus the dispensing fee; or

3. the provider's usual and customary charges to the general public not to exceed the department's "Maximum Pharmaceutical Price Schedule." *General public* is defined here as all other non-Medicaid prescriptions including:

- a. third party insurance;
- b. pharmacy benefit management; or

c. cash.

4. Repealed.

D. - E.2. ...

AUTHORITY NOTE: Promulgated in accordance with R.S. 36:254 and Title XIX of the Social Security Act.

HISTORICAL NOTE: Promulgated by the Department of Health and Hospitals, Office of the Secretary, Bureau of Health Services Financing, LR 32:1065 (June 2006), amended LR 34:88 (January 2008), amended by the Department of Health and Hospitals, Bureau of Health Services Financing, LR 36:1561 (July 2010), amended LR 39:

Subchapter E. 340B Program

§961. Definitions

Estimated Acquisition Cost (EAC)—the average acquisition cost of the drug dispensed. If there is not an AAC available, the EAC is equal to the wholesale acquisition cost, as reported in the drug pricing compendia utilized by the department's fiscal intermediary.

Wholesale Acquisition Cost (WAC)—the manufacturer's published catalog price for a drug product to wholesalers as reported to Medicaid by one or more national compendia on a weekly basis.

AUTHORITY NOTE: Promulgated in accordance with R.S. 36:254 and Title XIX of the Social Security Act.

HISTORICAL NOTE: Promulgated by the Department of Health and Hospitals, Office of the Secretary, Bureau of Health Services Financing, LR 32:1066 (June 2006), amended by the Department of Health and Hospitals, Bureau of Health Services Financing, LR 39:

§963. Reimbursement

A. - B. ...

C. Dispensing Fees. The covered entity shall be paid a dispensing fee of \$10.13 for each prescription dispensed to a Medicaid patient. With respect to contract pharmacy arrangements in which the contract pharmacy also serves as the covered entity's billing agent, the contract pharmacy shall be paid the \$10.13 dispensing fee on behalf of the covered entity.

AUTHORITY NOTE: Promulgated in accordance with R.S. 36:254 and Title XIX of the Social Security Act.

HISTORICAL NOTE: Promulgated by the Department of Health and Hospitals, Office of the Secretary, Bureau of Health Services Financing, LR 32:1066 (June 2006), amended LR 34:88 (January 2008), amended by the Department of Health and Hospitals, Bureau of Health Services Financing, LR 36:1561 (July 2010), amended LR 39:

Subchapter F. Antihemophilia Drugs

§971. Reimbursement

A. Anti-hemophilia drugs purchased by a covered entity through the 340B Program and dispensed to Medicaid recipients shall be billed to Medicaid at actual acquisition cost plus 10 percent and the dispensing fee unless the covered entity has implemented the Medicaid carve-out option. If the covered entity has implemented the Medicaid carve-out option, such drugs shall be reimbursed at EAC plus the dispensing fee or the billed charges, whichever is less.

B. Anti-hemophilia drugs purchased by a non-340B covered entity shall be reimbursed at EAC plus the dispensing fee.

AUTHORITY NOTE: Promulgated in accordance with R.S. 36:254 and Title XIX of the Social Security Act.

HISTORICAL NOTE: Promulgated by the Department of Health and Hospitals, Office of the Secretary, Bureau of Health Services Financing, LR 34:881 (May 2008), amended by the Department of Health and Hospitals, Bureau of Health Services Financing, LR 39:

Implementation of the provisions of this Rule may be contingent upon the approval of the U.S. Department of Health and Human Services, Centers for Medicare and Medicaid Services (CMS), if it is determined that submission to CMS for review and approval is required.

Family Impact Statement

In compliance with Act 1183 of the 1999 Regular Session of the Louisiana Legislature, the impact of this proposed Rule on the family has been considered. It is anticipated that this proposed Rule will have no impact on family functioning, stability or autonomy as described in R.S. 49:972.

Public Comments

Interested persons may submit written comments to J. Ruth Kennedy, Bureau of Health Services Financing, P.O. Box 91030, Baton Rouge, LA 70821—9030. She is responsible for responding to inquiries regarding this proposed Rule.

Public Hearing

A public hearing on this proposed Rule is scheduled for Wednesday, November 28, 2012 at 9:30 a.m. in Room 118, Bienville Building, 628 North Fourth Street, Baton Rouge, LA. At that time all interested persons will be afforded an opportunity to submit data, views or arguments either orally or in writing. The deadline for receipt of all written comments is 4:30 p.m. on the next business day following the public hearing.

Bruce D. Greenstein
Secretary

FISCAL AND ECONOMIC IMPACT STATEMENT FOR ADMINISTRATIVE RULES RULE TITLE: Pharmacy Benefits Management Program Methods of Payment

I. ESTIMATED IMPLEMENTATION COSTS (SAVINGS) TO STATE OR LOCAL GOVERNMENT UNITS (Summary)

It is anticipated that the implementation of this proposed rule will result in a reduction in estimated state programmatic costs of \$2,811,212 for FY 12-13 \$3,586,690 for FY 13-14 and \$3,694,290 for FY 14-15. It is anticipated that \$1,230 (\$615 SGF and \$615 FED) will be expended in FY 12-13 for the state's administrative expense for promulgation of this proposed rule and the final rule.

II. ESTIMATED EFFECT ON REVENUE COLLECTIONS OF STATE OR LOCAL GOVERNMENTAL UNITS (Summary)

It is anticipated that the implementation of this proposed rule will reduce federal revenue collections by approximately \$5,601,163 for FY 12-13, \$6,812,526 for FY 13-14 and \$7,016,902 for FY 14-15. It is anticipated that \$615 will be expended in FY 12-13 for the federal administrative expenses for promulgation of this proposed rule and the final rule.

III. ESTIMATED COSTS AND/OR ECONOMIC BENEFITS TO DIRECTLY AFFECTED PERSONS OR NONGOVERNMENTAL GROUPS (Summary)

This proposed rule continues the provisions of the September 5, 2012 emergency rule which repealed the March 20, 2010 Emergency Rule governing the methods of payment for prescription drugs in its entirety in order to revise the

provisions governing the methods of payment for prescription drugs and the dispensing fee. It is anticipated that implementation of this proposed rule will reduce programmatic expenditures in the Medicaid Program by approximately \$8,413,605 for FY 12-13, \$10,399,216 for FY 13-14 and \$10,711,192 for FY 14-15.

IV. ESTIMATED EFFECT ON COMPETITION AND EMPLOYMENT (Summary)

It is anticipated that the implementation of this proposed rule will not have an effect on competition and employment.

J. Ruth Kennedy
Medicaid Director
1210#057

John D. Carpenter
Legislative Fiscal Officer
Legislative Fiscal Office

NOTICE OF INTENT

Department of Health and Hospitals Bureau of Health Services Financing and Office of Public Health

Professional Services Program—Family Planning Services
Uncompensated Care Payments (LAC 50:IX.15143)

The Department of Health and Hospitals, Bureau of Health Services Financing amends LAC 50:IX.15143 in the Medical Assistance Program as authorized by R.S. 36:254 and pursuant to Title XIX of the Social Security Act. This proposed Rule is promulgated in accordance with the provisions of the Administrative Procedure Act, R.S. 49:950 et seq.

As a result of a budgetary shortfall in state fiscal year 2010, the Department of Health and Hospitals, Bureau of Health Services Financing amended the provisions governing the Professional Services Program to reduce the reimbursement rates for family planning services and to promulgate these provisions in a codified format for inclusion in the *Louisiana Administrative Code* (*Louisiana Register*, Volume 36, Number 11).

The Department of Health and Hospitals, Bureau of Health Services Financing and the Office of Public Health (OPH) promulgated an Emergency Rule which adopted provisions to establish Medicaid payment of uncompensated care costs for services rendered by OPH to Medicaid eligible recipients (*Louisiana Register*, Volume 38, Number 7). This proposed Rule is being promulgated to amend the provisions governing the reimbursement methodology for family planning services covered in the Professional Services Program in order to continue the provisions of the July 1, 2012 Emergency Rule governing uncompensated care payments to OPH.

Title 50

PUBLIC HEALTH—MEDICAL ASSISTANCE Part IX. Professional Services Program

Subpart 15. Reimbursement

Chapter 151. Reimbursement Methodology Subchapter E. Family Planning Services §15143. Reimbursement

A. - D. ...

E. Office of Public Health Uncompensated Care Payments

1. Effective for dates of service on or after July 1, 2012, the department shall provide the Office of Public

Health (OPH) with Medicaid payment of their uncompensated care costs for services rendered to Medicaid recipients. The Office of Public Health shall certify public expenditures to the Medicaid Program in order to secure federal funding for services provided at the cost of OPH.

2. The OPH will submit an estimate of cost for services provided under this Chapter.

a. The estimated cost will be calculated based on the previous fiscal year's expenditures and reduced by the estimate of payments made for services to OPH under this Chapter, which will be referred to as the net uncompensated care cost. The uncompensated care cost will be reported on a quarterly basis.

3. Upon completion of the fiscal year, the Office of Public Health will submit a cost report which will be used as a settlement of cost within one year of the end of the fiscal year.

a. Any adjustments to the net uncompensated care cost for a fiscal year will be reported on the CMS Form 64 as a prior period adjustment in the quarter of settlement.

AUTHORITY NOTE: Promulgated in accordance with R.S. 36:254 and Title XIX of the Social Security Act.

HISTORICAL NOTE: Promulgated by the Department of Health and Hospitals, Bureau of Health Services Financing, LR 36:2566 (November 2010), amended by the Department of Health and Hospitals, Bureau of Health Services Financing and the Office of Public Health, LR 39:

Implementation of the provisions of this Rule may be contingent upon the approval of the U.S. Department of Health and Human Services, Centers for Medicare and Medicaid Services (CMS), if it is determined that submission to CMS for review and approval is required.

Family Impact Statement

In compliance with Act 1183 of the 1999 Regular Session of the Louisiana Legislature, the impact of this proposed Rule on the family has been considered. It is anticipated that this proposed Rule will have no impact on family functioning, stability or autonomy as described in R.S. 49:972.

Public Comments

Interested persons may submit written comments to J. Ruth Kennedy, Bureau of Health Services Financing, P.O. Box 91030, Baton Rouge, LA 70821-9030. She is responsible for responding to inquiries regarding this proposed Rule.

Public Hearing

A public hearing on this proposed Rule is scheduled for Wednesday, November 28, 2012 at 9:30 a.m. in Room 118, Bienville Building, 628 North Fourth Street, Baton Rouge, LA. At that time all interested persons will be afforded an opportunity to submit data, views or arguments either orally or in writing. The deadline for receipt of all written comments is 4:30 p.m. on the next business day following the public hearing.

Bruce D. Greenstein
Secretary

FISCAL AND ECONOMIC IMPACT STATEMENT FOR ADMINISTRATIVE RULES

RULE TITLE: Professional Services Program Family Planning Services—Uncompensated Care Payments

I. ESTIMATED IMPLEMENTATION COSTS (SAVINGS) TO STATE OR LOCAL GOVERNMENT UNITS (Summary)

It is anticipated that the implementation of this proposed rule will result in estimated state programmatic costs of \$138,201 for FY 12-13, \$146,686 for FY 13-14 and \$151,087 for FY 14-15; however, the state match shall be met through a certified public expenditure financing arrangement whereby the Office of Public Health (OPH) shall transfer to the Medicaid Program funds to secure federal match to make supplemental Medicaid payments to OPH for uncompensated care costs. It is anticipated that \$410 (\$205 SGF and \$205 FED) will be expended in FY 12-13 for the state's administrative expense for promulgation of this proposed rule and the final rule.

II. ESTIMATED EFFECT ON REVENUE COLLECTIONS OF STATE OR LOCAL GOVERNMENTAL UNITS (Summary)

It is anticipated that the implementation of this proposed rule will increase federal revenue collections by approximately \$275,123 for FY 12-13, \$278,615 for FY 13-14 and \$286,973 for FY 14-15. It is anticipated that \$205 will be expended in FY 12-13 for the federal administrative expenses for promulgation of this proposed rule and the final rule.

III. ESTIMATED COSTS AND/OR ECONOMIC BENEFITS TO DIRECTLY AFFECTED PERSONS OR NONGOVERNMENTAL GROUPS (Summary)

This proposed Rule, which continues the provisions of the July 1, 2012 emergency rule, is being promulgated to amend the provisions governing the reimbursement methodology for family planning services covered in the Professional Services Program in order to reimburse supplemental Medicaid payments to the Office of Public Health for their uncompensated care costs for family planning services rendered to Medicaid recipients. It is anticipated that implementation of this proposed rule will increase programmatic expenditures in the Medicaid Program by approximately \$412,914 for FY 12-13, \$425,301 for FY 13-14 and \$438,060 for FY 14-15.

IV. ESTIMATED EFFECT ON COMPETITION AND EMPLOYMENT (Summary)

It is anticipated that the implementation of this proposed rule will not have an effect on competition and employment.

J. Ruth Kennedy
Medicaid Director
1210#058

John D. Carpenter
Legislative Fiscal Officer
Legislative Fiscal Office

NOTICE OF INTENT

Department of Health and Hospitals Bureau of Health Services Financing and Office of Public Health

Professional Services Program—Immunizations
Uncompensated Care Payments
(LAC 50:IX.8305, 8505 and 8701)

The Department of Health and Hospitals, Bureau of Health Services Financing proposes to amend LAC 50:XV.8305, adopt §8505, and repeal §8701 in the Medical

Assistance Program as authorized by R.S. 36:254 and pursuant to Title XIX of the Social Security Act. This proposed Rule is promulgated in accordance with the provisions of the Administrative Procedure Act, R.S. 49:950 et seq.

The Department of Health and Hospitals, Office of the Secretary, Bureau of Health Services Financing adopted provisions which authorized reimbursement of adult immunizations for influenza, pneumococcal, and HPV diseases (*Louisiana Register*, Volume 34, Number 6). In January 2009, the department also adopted provisions which amended the reimbursement methodology governing Medicaid payments to providers for the administration of vaccines to children, and incorporated these provisions into the *Louisiana Administrative Code* (LAC) in a codified format (*Louisiana Register*, Volume 35, Number 1).

The Department of Health and Hospitals, Bureau of Health Services Financing and the Office of Public Health (OPH) promulgated an Emergency Rule which adopted provisions to establish Medicaid payment of uncompensated care costs for services rendered by OPH to Medicaid eligible recipients (*Louisiana Register*, Volume 38, Number 7). This proposed Rule is being promulgated to amend the provisions governing the reimbursement of children's and adult immunization services rendered by the Office of Public Health in order to continue the provisions of the July 1, 2012 Emergency Rule governing uncompensated care payments to OPH. This proposed Rule will also repromulgate the reimbursement methodology governing adult immunizations in LAC 50:XV.8505 in order to ensure that the provisions are promulgated in a clear and concise manner in the LAC.

Title 50

PUBLIC HEALTH—MEDICAL ASSISTANCE

Part IX. Professional Services Program

Subpart 7. Immunizations

Chapter 83. Children's Immunizations

§8305. Reimbursement Methodology

A. - B. ...

C. Office of Public Health Uncompensated Care Payments

1. Effective for dates of service on or after July 1, 2012, the department shall provide the Office of Public Health (OPH) with Medicaid payment of their uncompensated care costs for immunization services rendered to Medicaid recipients. The Office of Public Health shall certify public expenditures to the Medicaid Program in order to secure federal funding for services provided at the cost of OPH.

2. The OPH will submit an estimate of cost for services provided under this Chapter.

a. The estimated cost will be calculated based on the previous fiscal year's expenditures and reduced by the estimate of payments made for services to OPH under this Chapter, which will be referred to as the net uncompensated care cost. The uncompensated care cost will be reported on a quarterly basis

3. Upon completion of the fiscal year, the Office of Public Health will submit a cost report which will be used as a settlement of cost within one year of the end of the fiscal year.

a. Any adjustments to the net uncompensated care cost for a fiscal year will be reported on the CMS Form 64 as a prior period adjustment in the quarter of settlement.

AUTHORITY NOTE: Promulgated in accordance with R.S. 36:254 and Title XIX of the Social Security Act.

HISTORICAL NOTE: Promulgated by the Department of Health and Hospitals, Office of the Secretary, Bureau of Health Services Financing, LR 35:71 (January 2009), amended by the Department of Health and Hospitals, Bureau of Health Services Financing and the Office of Public Health, LR 39:

Chapter 85. Adult Immunizations

§8505. Reimbursement Methodology

A. Providers shall be reimbursed according to the established fee schedule for the vaccine and the administration of the vaccine.

B. Office of Public Health Uncompensated Care Payments

1. Effective for dates of service on or after July 1, 2012, the department shall provide the Office of Public Health (OPH) with Medicaid payment of their uncompensated care costs for immunization services rendered to Medicaid recipients. The Office of Public Health shall certify public expenditures to the Medicaid Program in order to secure federal funding for services provided at the cost of OPH.

2. The OPH will submit an estimate of cost for services provided under this Chapter.

a. The estimated cost will be calculated based on the previous fiscal year's expenditures and reduced by the estimate of payments made for services to OPH under this Chapter, which will be referred to as the net uncompensated care cost. The uncompensated care cost will be reported on a quarterly basis

3. Upon completion of the fiscal year, the Office of Public Health will submit a cost report which will be used as a settlement of cost within one year of the end of the fiscal year.

a. Any adjustments to the net uncompensated care cost for a fiscal year will be reported on the CMS Form 64 as a prior period adjustment in the quarter of settlement.

AUTHORITY NOTE: Promulgated in accordance with R.S. 36:254 and Title XIX of the Social Security Act.

HISTORICAL NOTE: Promulgated by the Department of Health and Hospitals, Bureau of Health Services Financing and the Office of Public Health, LR 39:

Chapter 87. Reimbursement

§8701. Reimbursement Methodology

A. Repealed.

AUTHORITY NOTE: Promulgated in accordance with R.S. 36:254 and Title XIX of the Social Security Act.

HISTORICAL NOTE: Promulgated by the Department of Health and Hospitals, Office of the Secretary, Bureau of Health Services Financing, LR 34:1035 (June 2008), repealed by the Department of Health and Hospitals, Bureau of Health Services Financing and the Office of Public Health, LR 39:

Implementation of the provisions of this Rule may be contingent upon the approval of the U.S. Department of Health and Human Services, Centers for Medicare and Medicaid Services (CMS), if it is determined that submission to CMS for review and approval is required.

Family Impact Statement

In compliance with Act 1183 of the 1999 Regular Session of the Louisiana Legislature, the impact of this proposed Rule on the family has been considered. It is anticipated that this proposed Rule will have no impact on family functioning, stability and autonomy as described in R.S. 49:972.

Public Comments

Interested persons may submit written comments to J. Ruth Kennedy, Bureau of Health Services Financing, P.O. Box 91030, Baton Rouge, LA 70821-9030. She is responsible for responding to inquiries regarding this proposed Rule.

Public Hearing

A public hearing on this proposed Rule is scheduled for Wednesday, November 28, 2012 at 9:30 a.m. in Room 118, Bienville Building, 628 North Fourth Street, Baton Rouge, LA. At that time all interested persons will be afforded an opportunity to submit data, views or arguments either orally or in writing. The deadline for receipt of all written comments is 4:30 p.m. on the next business day following the public hearing.

Bruce D. Greenstein
Secretary

FISCAL AND ECONOMIC IMPACT STATEMENT FOR ADMINISTRATIVE RULES

RULE TITLE: Professional Services

Program—Immunizations Uncompensated Care Payments

I. ESTIMATED IMPLEMENTATION COSTS (SAVINGS) TO STATE OR LOCAL GOVERNMENT UNITS (Summary)

It is anticipated that the implementation of this proposed rule will result in estimated state programmatic costs of \$399,966 for FY 12-13, \$424,894 for FY 13-14 and \$437,641 for FY 14-15; however, the state match shall be met through a certified public expenditure financing arrangement whereby the Office of Public Health shall transfer to the department funds to secure federal match to make supplemental Medicaid payments to OPH for uncompensated care costs. It is anticipated that \$492 (\$246 SGF and \$246 FED) will be expended in FY 12-13 for the state's administrative expense for promulgation of this proposed rule and the final rule.

II. ESTIMATED EFFECT ON REVENUE COLLECTIONS OF STATE OR LOCAL GOVERNMENTAL UNITS (Summary)

It is anticipated that the implementation of this proposed rule will increase federal revenue collections by approximately \$796,577 for FY 12-13, \$807,039 for FY 13-14 and \$831,250 for FY 14-15. It is anticipated that \$246 will be expended in FY 12-13 for the federal administrative expenses for promulgation of this proposed rule and the final rule.

III. ESTIMATED COSTS AND/OR ECONOMIC BENEFITS TO DIRECTLY AFFECTED PERSONS OR NONGOVERNMENTAL GROUPS (Summary)

This proposed Rule, which continues the provisions of the July 1, 2012 emergency rule, is being promulgated to amend the provisions governing the reimbursement of children and adult immunizations rendered by the Office of Public Health in order to reimburse supplemental Medicaid payments for their uncompensated care costs for these services. It is anticipated that implementation of this proposed rule will increase programmatic expenditures in the Medicaid Program by approximately \$1,196,051 for FY 12-13, \$1,231,933 for FY 13-14 and \$1,268,891 for FY 14-15.

IV. ESTIMATED EFFECT ON COMPETITION AND EMPLOYMENT (Summary)

It is anticipated that the implementation of this proposed rule will not have an effect on competition and employment.

J. Ruth Kennedy
Medicaid Director
1210#059

John D. Carpenter
Legislative Fiscal Officer
Legislative Fiscal Office

NOTICE OF INTENT

Department of Health and Hospitals Bureau of Health Services Financing and Office of Public Health

Targeted Case Management—Nurse Family Partnership
Program—Uncompensated Care Payments
(LAC 50:XV.10701)

The Department of Health and Hospitals, Bureau of Health Services Financing proposes to amend LAC 50:XV.10701 in the Medical Assistance Program as authorized by R.S. 36:254 and pursuant to Title XIX of the Social Security Act. This proposed Rule is promulgated in accordance with the provisions of the Administrative Procedure Act, R.S. 49:950 et seq.

The Department of Health and Hospitals, Bureau of Health Services Financing amended the provisions governing the reimbursement methodology for targeted case management (TCM) services to reduce the reimbursement rates paid for TCM services provided in the Nurse Family Partnership (NFP) Program and to restrict reimbursement of TCM services in the NFP Program to prenatal and postnatal services only (*Louisiana Register*, Volume 36, Number 8).

The Department of Health and Hospitals, Bureau of Health Services Financing and the Office of Public Health (OPH) promulgated an Emergency Rule which adopted provisions to establish Medicaid payment of uncompensated care costs for services rendered by OPH to Medicaid eligible recipients (*Louisiana Register*, Volume 38, Number 7). This proposed Rule is being promulgated to amend the provisions governing the reimbursement of targeted case management services rendered by the Office of Public Health in the Nurse Family Partnership Program in order to continue the provisions of the July 1, 2012 Emergency Rule governing uncompensated care payments to OPH.

Title 50

PUBLIC HEALTH—MEDICAL ASSISTANCE

Part XV. Services for Special Populations

Subpart 7. Targeted Case Management

Chapter 107. Reimbursement

§10701. Reimbursement

A. - G.4. ...

H. Office of Public Health Uncompensated Care Payments

1. Effective for dates of service on or after July 1, 2012, the department shall provide the Office of Public Health (OPH) with Medicaid payment of their uncompensated care costs for services rendered to Medicaid recipients in the Nurse Family Partnership Program. The Office of Public Health shall certify public expenditures to

the Medicaid Program in order to secure federal funding for services provided at the cost of OPH.

2. The OPH will submit an estimate of cost for services provided under this Chapter.

a. The estimated cost will be calculated based on the previous fiscal year's expenditures and reduced by the estimate of payments made for services to OPH under this Chapter, which will be referred to as the net uncompensated care cost. The uncompensated care cost will be reported on a quarterly basis

3. Upon completion of the fiscal year, the Office of Public Health will submit a cost report which will be used as a settlement of cost within one year of the end of the fiscal year.

a. Any adjustments to the net uncompensated care cost for a fiscal year will be reported on the CMS Form 64 as a prior period adjustment in the quarter of settlement.

AUTHORITY NOTE: Promulgated in accordance with R.S. 36:254 and Title XIX of the Social Security Act.

HISTORICAL NOTE: Promulgated by the Department of Health and Hospitals, Office of the Secretary, Bureau of Health Services Financing, LR 30:1040 (May 2004), amended LR 31:2032 (August 2005), LR 35:73 (January 2009), amended by the Department of Health and Hospitals, Bureau of Health Services Financing, LR 35:1903 (September 2009), LR 36:1783 (August 2010), amended by the Department of Health and Hospitals, Bureau of Health Services Financing and the Office of Public Health, LR 39:

Implementation of the provisions of this Rule may be contingent upon the approval of the U.S. Department of Health and Human Services, Centers for Medicare and Medicaid Services (CMS), if it is determined that submission to CMS for review and approval is required.

Family Impact Statement

In compliance with Act 1183 of the 1999 Regular Session of the Louisiana Legislature, the impact of this proposed Rule on the family has been considered. It is anticipated that this proposed Rule will have no impact on family functioning, stability and autonomy as described in R.S. 49:972.

Public Comments

Interested persons may submit written comments to J. Ruth Kennedy, Bureau of Health Services Financing, P.O. Box 91030, Baton Rouge, LA 70821-9030. She is responsible for responding to inquiries regarding this proposed Rule.

Public Hearing

A public hearing on this proposed Rule is scheduled for Wednesday, November 28, 2012 at 9:30 a.m. in Room 118, Bienville Building, 628 North Fourth Street, Baton Rouge, LA. At that time all interested persons will be afforded an opportunity to submit data, views or arguments either orally or in writing. The deadline for receipt of all written comments is 4:30 p.m. on the next business day following the public hearing.

Bruce D. Greenstein
Secretary

FISCAL AND ECONOMIC IMPACT STATEMENT FOR ADMINISTRATIVE RULES

RULE TITLE: Targeted Case Management Nurse Family Partnership Program Uncompensated Care Payments

I. ESTIMATED IMPLEMENTATION COSTS (SAVINGS) TO STATE OR LOCAL GOVERNMENT UNITS (Summary)

It is anticipated that the implementation of this proposed rule will result in estimated state programmatic costs of \$114,595 for FY 12-13, \$134,251 for FY 13-14 and \$138,279 for FY 14-15; however, the state match shall be met through a certified public expenditure financing arrangement whereby the Office of Public Health (OPH) shall transfer to the department funds to secure federal match to make supplemental Medicaid payments to OPH for uncompensated care costs. It is anticipated that \$328 (\$164 SGF and \$164 FED) will be expended in FY 12-13 for the state's administrative expense for promulgation of this proposed rule and the final rule.

II. ESTIMATED EFFECT ON REVENUE COLLECTIONS OF STATE OR LOCAL GOVERNMENTAL UNITS (Summary)

It is anticipated that the implementation of this proposed rule will increase federal revenue collections by approximately \$263,642 for FY 12-13, \$254,995 for FY 13-14 and \$262,645 for FY 14-15. It is anticipated that \$164 will be expended in FY 12-13 for the federal administrative expenses for promulgation of this proposed rule and the final rule.

III. ESTIMATED COSTS AND/OR ECONOMIC BENEFITS TO DIRECTLY AFFECTED PERSONS OR NONGOVERNMENTAL GROUPS (Summary)

This proposed Rule, which continues the provisions of the July 1, 2012 emergency rule, is being promulgated to amend the provisions governing the reimbursement methodology for targeted case management (TCM) services covered in the Nurse Family Partnership Program in order to reimburse supplemental Medicaid payments to OPH for their uncompensated care costs for TCM services rendered to Medicaid recipients. It is anticipated that implementation of this proposed rule will increase programmatic expenditures in the Medicaid Program by approximately \$377,909 for FY 12-13, \$389,246 for FY 13-14 and \$400,924 for FY 14-15.

IV. ESTIMATED EFFECT ON COMPETITION AND EMPLOYMENT (Summary)

It is anticipated that the implementation of this proposed rule will not have an effect on competition and employment.

J. Ruth Kennedy
Medicaid Director
1210#060

John D. Carpenter
Legislative Fiscal Officer
Legislative Fiscal Office

NOTICE OF INTENT

Department of Public Safety and Corrections Board of Pardons Committee on Parole

Committee on Parole—Membership, Duties, and Functions
(LAC 22:XI.101-122, 501-514, 701-711,
901, 903, 907, 909, 911, 1501, and 1503)

In accordance with the provisions of the Administrative Procedure Act (R.S. 49:950), the Board of Pardons/Committee on Parole, hereby gives notice of its intent to amend its rules and promulgate rules of LAC

22:XI.101-122, 501-514, 701-711, 901-909, and 1501-1503. This rulemaking implements Act 714 of the 2012 Regular Session of the Louisiana Legislature. Act 714 merges the functions and duties of the Board of Parole into the Board of Pardons; creates a committee on parole, provides for its membership, duties, and functions of the committee on parole.

Title 22

CORRECTIONS, CRIMINAL JUSTICE AND LAW ENFORCEMENT

Part XI. Committee on Parole

Chapter 1. Administration

§101. Authority

A. The Louisiana Committee on Parole, hereinafter referred to as "the committee," has the authority to determine the time and conditions of release on parole of any person who has been convicted of a felony and sentenced to the Louisiana Department of Public Safety and Corrections and who is statutorily eligible for parole consideration; and to determine and impose sanctions for violation of the conditions of parole.

AUTHORITY NOTE: Promulgated in accordance with R.S. 15:574.2 et seq., R.S. 15:535 et seq., and R.S. 15:540 et seq.

HISTORICAL NOTE: Promulgated by the Department of Corrections, Board of Parole, LR 2:113 (April 1976), amended by the Department of Public Safety and Corrections, Board of Parole, LR 24:2292 (December 1998), amended by the Department of Public Safety and Corrections, Board of Pardons, Committee on Parole, LR 38:

§102. Powers and Duties of the Committee

A. The Louisiana Committee on Parole shall:

1. make parole release and revocation decisions under R.S. 15:574.2;
2. adopt rules not inconsistent with law as the committee deems necessary and proper with respect to the eligibility of offenders for parole and the conditions imposed upon offenders who are released on parole;
3. keep records of its official actions and make them accessible according to law;
4. collect, develop, and maintain statistical information concerning its services and decisions;
5. when requested to do so, submit written notification of the offender's pending release, at least seven days prior to the offender's date of release, to the chief of police, sheriff, or district attorney of the parish where the offender will reside and where the conviction(s) occurred ;
6. submit an annual report on the committee's performance to the Secretary of the Department of Public Safety and Corrections on or before February 1st each year for the previous calendar year, to include statistical and other data with respect to the determination and work of the committee, relevant data of committee decisions, a summary of past practices and outcomes, plans for the upcoming year, research studies which the committee may make of sentencing, parole, or related functions, and may include recommendations for changes considered necessary to improve its effectiveness.

B. The Louisiana Committee on Parole may:

1. apply to a district court to issue subpoenas, compel the attendance of witnesses, and the production of books, papers, and other documents pertinent to the subject of its inquiry;

2. take testimony under oath, either at a hearing or by deposition;

3. sanction an offender's disorderly, threatening, or insolent behavior, or use of insulting, abusive, or obscene language at a hearing or in written communications with the offender's parole application, notice for which shall be provided to the offender at, or prior to, the commencement of proceedings.

AUTHORITY NOTE: Promulgated in accordance with R.S. 15:574.2 et seq., R.S. 15:535 et seq., and R.S. 15:540 et seq.

HISTORICAL NOTE: Promulgated by the Department of Public Safety and Corrections, Board of Pardons, Committee on Parole, LR 38:

§103. Composition of the Committee

A.1. The committee shall be composed of the five members of the Board of Pardons, two at-large members appointed by the governor, who shall only serve as members of the Committee on Parole and shall not serve as members of the Board of Pardons. In addition to the seven members appointed by the governor, an ex-officio member shall serve on the committee. The chairman of the Board of Pardons shall serve as the chairman of the Committee on Parole.

a. The warden, or in his absence the deputy warden, of the correctional facility in which the offender is incarcerated shall be an ex officio member of the committee. When the offender is housed in a local correctional facility and the warden or deputy warden of that facility is not able to attend the offender's parole hearing, the warden, or in his absence the deputy warden, of the facility where the offender's parole hearing is held may serve as an ex officio member. The ex officio member shall not be a voting member nor shall he be counted or permitted to be counted for purposes of the number of members necessary to take committee action or the number of members necessary to establish quorum.

2. All members shall serve at the pleasure of the governor and each appointment shall be confirmed by the Senate.

3. Each member shall, except the ex officio member, devote full time to the duties of the office.

B. The chairman of the board shall be the chief administrative officer for the committee and shall be responsible for assuring that all meetings, hearings and administrative matters for the committee are properly conducted in accordance with law and with these rules or executive order.

C. The vice-chairman of the Board of Pardons shall act in place of the chairman in his or her absence and shall be responsible for any other administrative duties as directed by the chairman or as provided by law or executive order. In the event that the vice-chairman is incapacitated or otherwise unable to perform his or her duties for any reason, the chairman shall perform such duties until the vice-chairman is able to resume performance of his or her duties.

D. All members appointed after August 15, 2010 shall possess not less than five years actual experience in the field of corrections, law enforcement, sociology, law, education, social work, medicine, or a combination thereof.

AUTHORITY NOTE: Promulgated in accordance with R.S. 15:574.2 et seq., R.S. 15:535 et seq., and R.S. 15:540 et seq.

HISTORICAL NOTE: Promulgated by the Department of Corrections, Board of Parole, LR 2:113 (April 1976), amended by

the Department of Public Safety and Corrections, Board of Parole, LR 24:2292 (December 1998), amended by Department of Public Safety and Corrections, Corrections Services, LR 36:2872 (December 2010), amended by the Department of Public Safety and Corrections, Board of Pardons, Committee on Parole, LR 38:

§105. Headquarters

Repealed.

AUTHORITY NOTE: Promulgated in accordance with R.S. 15:574.2 et seq., R.S. 15:535 et seq., and R.S. 15:540 et seq.

HISTORICAL NOTE: Promulgated by the Department of Corrections, Board of Parole, LR 2:113 (April 1976), amended by the Department of Public Safety and Corrections, Board of Parole, LR 24:2292 (December 1998), repealed by the Department of Public Safety and Corrections, Board of Pardons, Committee on Parole, LR 38:

§107. Powers and Duties of the Board

Repealed.

AUTHORITY NOTE: Promulgated in accordance with R.S. 15:574.2 et seq., R.S. 15:535 et seq., and R.S. 15:540 et seq.

HISTORICAL NOTE: Promulgated by the Department of Corrections, Board of Parole, LR 2:114 (April 1976), amended by the Department of Public Safety and Corrections, Board of Parole, LR 24:2293 (December 1998), repealed by the Department of Public Safety and Corrections, Board of Pardons, Committee on Parole, LR 38:

§108. Mission Statement

A. The mission of the Louisiana Committee on Parole is to determine the time and conditions of release for eligible offenders in a manner that ensures public safety and facilitates an offender's reintegration into society, recognizing that the parole process is an essential element of the criminal justice system.

B. Using evidence based research, the parole decision makers (committee members) shall:

1. render just determination in regard to parole release and revocations, thereby maximizing the restoration of human potential while restraining the growth of the Louisiana prison population;

2. impose reasonable and prudent conditions of release consistent with the goal of structured reintegration of an offender's release into the community; and

3. impose realistic and relevant conditions of release tailored to the specific offender.

C. The committee seeks to promote successful offender reentry by maintaining contact during supervision to not only intervene and address violation behavior, but to acknowledge and support compliance and accomplishments.

AUTHORITY NOTE: Promulgated in accordance with R.S. 15:574.2 et seq., R.S. 15:535 et seq., and R.S. 15:540 et seq.

HISTORICAL NOTE: Promulgated by the Department of Public Safety and Corrections, Board of Pardons, Committee on Parole, LR 38:

§109. Restrictions on the Representation of Offenders

A. The following persons shall not represent any offender, directly or indirectly, before the committee:

A.1. - B.

AUTHORITY NOTE: Promulgated in accordance with R.S. 15:574.2 et seq., R.S. 15:535 et seq., and R.S. 15:540 et seq.

HISTORICAL NOTE: Promulgated by the Department of Corrections, Board of Parole, LR 2:114 (April 1976), amended by the Department of Public Safety and Corrections, Board of Parole, LR 24:2293 (December 1998), amended by the Department of Public Safety and Corrections, Board of Pardons, Committee on Parole, LR 38:

§111. Communications between Committee Members

A. There shall be no informal, off-the-record communications regarding the merits or the substance of an offender's case between committee members for the purpose of influencing a decision of the committee outside of an official public hearing. The warden or deputy warden, as ex officio member, may provide information to other members of the committee regarding an offender's progress during incarceration. Such communication may be submitted in writing in advance of the offender's scheduled hearing or may be provided verbally during the course of the public hearing; however, as an ex officio member, the warden or deputy Warden shall not be a voting member of the committee. Any attempt by a committee member to discuss cases in an effort to persuade another committee member or members outside of an official public hearing shall be documented as set forth in §113.D.1-3.

AUTHORITY NOTE: Promulgated in accordance with R.S. 15:574.2 et seq., R.S. 15:535 et seq., and R.S. 15:540 et seq.

HISTORICAL NOTE: Promulgated by the Department of Corrections, Board of Parole, LR 2:115 (April 1976), amended by the Department of Public Safety and Corrections, Board of Parole, LR 24:2294 (December 1998), amended by the Department of Public Safety and Corrections, Board of Pardons, Committee on Parole, LR 38:

§113. Communications with Committee Members

A.1. No member of the committee shall transmit any correspondence to, or otherwise confer with, a judge before whom a convicted offender is awaiting sentencing to request or recommend any action relating to the sentence to be imposed upon the offender.

2. The committee shall notify the governor of its finding of a violation of this Section. However, no decision of the committee shall be nullified or otherwise affected by the participation of a member who has violated this section, except a decision that involves the offender on whose behalf the request or recommendation was made.

B. Notwithstanding the provisions of R.S. 15:574.12(A), or any other provision of law to the contrary, no person shall contact or communicate with the committee or any of its members urging parole, or otherwise regarding any offender, except in an open hearing/meeting or by written letter addressed to the committee.

1. Any written communication with the committee regarding an offender as provided in this section shall be deemed a public record and subject to public inspection as provided by R.S. 44:1 et seq.

2. Letters written by or on behalf of any victim of a crime committed by the offender, or any letter written in opposition to the offender being placed on parole shall not be deemed a public record. However, this exception shall not apply to any written communication by an elected or appointed official.

C. Any member of the committee improperly contacted by an individual shall immediately cease the inappropriate communication with the individual, notify the individual in writing, return receipt requested, accompanied by a copy of this rule, that such contact was illegal and inappropriate, and report the contact to the other committee members.

1. Any person who persists in violating the provisions of this section, after being informed of the inappropriate

contact as provided in this section, shall be reported to the appropriate district attorney for prosecution.

2. If convicted, the violator shall be fined not more than \$500 or imprisoned for not more than six months, or both.

D. Any oral communication received by a committee member with the intent to affect the outcome of any offender's case shall be documented in writing.

1. The written documentation shall include the name of the individual making the contact, date and time of the contact, type of communication, name of offender, nature of the request and committee member's action.

2. A copy of such written documentation shall be kept in a central registry at the committee office and shall be subject to public inspection.

E. Copies of any written communication received by a committee member shall be made available to all committee members and shall be subject to public inspection.

F. Any public records' request directed to the committee or its staff should be made in writing. The chairman or his or her designee and/or the committee's attorney shall review and approve or disapprove the request in accordance with R.S. 15:574.12 and R.S. 44:1 et seq.

AUTHORITY NOTE: Promulgated in accordance with R.S. 15:574.2 et seq., R.S. 15:535 et seq., and R.S. 15:540 et seq.

HISTORICAL NOTE: Promulgated by the Department of Corrections, Board of Parole, LR 2:115 (April 1976), amended by the Department of Public Safety and Corrections, Board of Parole, LR 24:2294 (December 1998), amended by the Department of Public Safety and Corrections, Board of Pardons, Committee on Parole, LR 38:

§115. Ethics and Conflicts of Interest

A. Members of the committee are subject to the constraints imposed by the Louisiana Code of Governmental Ethics, which ensures the public confidence in the integrity of government.

B. Any member of the committee who has a conflict of interest must recuse himself or herself from a matter pending before the committee. A conflict of interest may include, but not be limited to the following.

1. The committee member is a witness.

2. The committee member has been employed as an attorney for the offender.

3. The attorney for the offender is the spouse of a committee member or is related to a committee member.

4. The offender is a relative of a committee member.

5. The committee member is biased, prejudiced, or interested in the case or its outcome, or biased or prejudiced toward or against the offender or the offender's attorney to the extent that he/she would be unable to fairly and impartially participate in the hearing.

C. If a committee member fails to recuse himself or herself, any interested person may request in writing to the chairman of the committee that a member be recused. This request should include detailed reasons why a member should be recused.

D. If the member fails to recuse himself or herself, the matter shall be referred to the committee.

AUTHORITY NOTE: Promulgated in accordance with R.S. 15:574.2 et seq., R.S. 15:535 et seq., and R.S. 15:540 et seq.

HISTORICAL NOTE: Promulgated by the Department of Corrections, Board of Parole, LR 2:115 (April 1976), amended by the Department of Public Safety and Corrections, Board of Parole,

LR 24:2294 (December 1998), amended by the Department of Public Safety and Corrections, Board of Pardons, Committee on Parole, LR 38:

§117. Training

A. Within 90 days of being appointed to the committee, each member shall complete a comprehensive training course developed by the Department of Public Safety and Corrections. Each member shall complete a minimum of eight hours of training annually.

B. Each committee member shall be issued a *Rules and Procedures Manual* and shall sign a statement to acknowledge receipt of the manual. Such statement shall include the committee member's agreement to completely and thoroughly familiarize himself or herself with the information contained therein and to conduct himself at all times in a manner which will strictly adhere to the letter of the law, as well as the spirit and intent. The manual shall contain, but not be limited to, a copy of the following:

1. Louisiana Board of Pardon/Committee on Parole Rules and Procedures;

2. Code of Governmental Ethics;

3. R.S. 42:1 et seq. (Public Policy for Open Meetings Law);

4. all Department of Public Safety and Corrections regulations and/or statutes with particular reference to the operations of the committee.

AUTHORITY NOTE: Promulgated in accordance with R.S. 15:574.2 et seq., R.S. 15:535 et seq., and R.S. 15:540 et seq.

HISTORICAL NOTE: Promulgated by the Department of Corrections, Board of Parole, LR 2:115 (April 1976), amended by the Department of Public Safety and Corrections, Board of Parole, LR 24:2294 (December 1998), amended by the Department of Public Safety and Corrections, Board of Pardons, Committee on Parole, LR 38:

§119. Legislative Briefing

Repealed.

AUTHORITY NOTE: Promulgated in accordance with R.S. 15:574.2 et seq., R.S. 15:535 et seq., and R.S. 15:540 et seq.

HISTORICAL NOTE: Promulgated by the Department of Corrections, Board of Parole, LR 2:116 (April 1976), amended by the Department of Public Safety and Corrections, Board of Parole, LR 24:2295 (December 1998), repealed by the Department of Public Safety and Corrections, Board of Pardons, Committee on Parole, LR 38:

§121. Committee Spokesperson

A. Only the chairman of the committee or, in the absence of the chairman, the vice-chairman shall be authorized to speak on behalf of the entire committee.

AUTHORITY NOTE: Promulgated in accordance with R.S. 15:574.2 et seq., R.S. 15:535 et seq., and R.S. 15:540 et seq.

HISTORICAL NOTE: Promulgated by the Department of Corrections, Board of Parole, LR 2:116 (April 1976), amended by the Department of Public Safety and Corrections, Board of Parole, LR 24:2295 (December 1998), amended by the Department of Public Safety and Corrections, Board of Pardons, Committee on Parole, LR 38:

§122. Records Management and Confidentiality of Information

A. Parolee Record

1. The committee shall cause a complete record to be kept of every inmate released on parole. Such records shall be organized in accordance with the most modern methods of filing and indexing so that there always will be immediate availability of complete information about such inmate.

B. Records Management and Retention

1. The committee shall implement a records management program to ensure all Committee on Parole vital records are stored managed, and disposed of in accordance with state law. The committee shall use the Records Retention Schedule created and maintained by the Department of Public Safety and Corrections, Corrections Services.

C. Release of Information—Sex Offenders

1. The committee is authorized to release to the public the following information regarding sex offenders:

- a. name and address;
- b. crime of conviction and date of conviction;
- c. date of release on parole or diminution of sentence;
- d. most recent photograph available; and
- e. any other information that may be necessary and relevant for public protection.

2. Verbal requests for such information are acceptable.

3. The chairman of the committee or his or her designee may require a written request before releasing any information.

4. The committee cannot release any information regarding victims or witnesses of sex crimes to the sex offender or the general public.

D. Release of Information—Minor Victim(s)

1. In addition to any other information authorized to be released, the committee may, pursuant to R.S. 15:546, release information concerning any offender under the jurisdiction of the committee who is convicted of any sex offense or criminal offense against a victim who is a minor, or who has been determined to be a sexually violent predator.

E. Release of Information—Criminal Convictions

1. The committee may disseminate information regarding an offender's criminal convictions without restriction.

F. Other information regarding an offender's criminal history records, including nonconviction history may only be released subject to the restrictions outlined in R.S. 15:548. Unless the request is made by a representative of a criminal justice agency or a juvenile justice agency, such information shall, under normal circumstances, be released only pursuant to a written request.

G. The committee shall be immune from liability for the release of information concerning any sex offender, sexually violent predator, or child predator.

AUTHORITY NOTE: Promulgated in accordance with R.S. 15:574.2 et seq., R.S. 15:535 et seq., and R.S. 15:540 et seq.

HISTORICAL NOTE: Promulgated by the Department of Public Safety and Corrections, Board of Pardons, Committee on Parole, LR 38:

Chapter 5. Meetings and Hearings of the Committee on Parole

§501. Types of Meetings

A. All meetings and hearings of the committee shall be open to the public. For the purpose of convenience and in order to differentiate between the different types of forums for conducting business, the following designation or title has been given, depending upon the nature of the matters or actions to be considered:

1. a *business meeting* is a meeting of the full committee to discuss all general business matters as set forth in §507;

2. a *public hearing* is a meeting of randomly selected, three-member panels, as set forth in §511.

AUTHORITY NOTE: Promulgated in accordance with R.S. 15:574.2 et seq., R.S. 15:535 et seq., and R.S. 15:540 et seq.

HISTORICAL NOTE: Promulgated by the Department of Public Safety and Corrections, Board of Parole, LR 24:2298 (December 1998), amended by the Department of Public Safety and Corrections, Board of Pardons, Committee on Parole, LR 38:

§503. Parole Panels

A. The committee shall meet in panels comprised of at least three members of the committee, except as otherwise provided in these rules.

B. The chairman of the committee shall randomly assign all three-member panels. Each panel shall appoint the chairperson of that three-member panel.

C. The random selection of panels shall be done in such a manner as to result in the smallest probability of having a panel constituted by the same three members for two consecutive months.

D. In the event that a committee member requests a change in the composition of a panel to which that member has been assigned, the reason for such request must be made in writing to the vice-chairman of the committee for approval. This does not include emergencies, illness, etc. on the day of the hearings/meetings.

1. When an emergency request is made on the date of the hearing/meeting, the explanation for such emergency must be submitted in writing upon the panel member's return to work as promptly as practical.

2. There will be no substitutions of panel members except in cases of either illness or emergencies.

AUTHORITY NOTE: Promulgated in accordance with R.S. 15:574.2 et seq. and R.S. 15:540 et seq.

HISTORICAL NOTE: Promulgated by the Department of Public Safety and Corrections, Board of Parole, LR 24:2298 (December 1998), amended by the Department of Public Safety and Corrections, Corrections Services, LR 36:2872 (December 2010), amended by the Department of Public Safety and Corrections, Board of Pardons, Committee on Parole, LR 38:

§505. General Procedures

A. The committee will conduct its business meetings; and public hearings in accordance with the provisions of R.S. 42:1 et seq. (Public Policy for Open Meetings Law) and *Robert's Rules of Order*.

1. At business meetings, detailed minutes indicating time of commencement, persons present (including visitors and witnesses), adoption of previous minutes, motions and seconds, and time of adjournment shall be recorded and maintained by the committee staff member so designated by the chairman.

2. The committee's minutes of public hearings shall include the following information as applicable:

a. name and Department of Corrections (DOC) number of the offender;

b. name of counsel representing the offender (an offender docketed for a public hearing may be represented by counsel);

c. the vote of each member; and

d. the decision of the committee.

B.1. The vote of each panel member shall be recorded by name and date on the vote sheet.

2. Only those members present shall vote; voting by proxy is prohibited.

3. No vote shall be taken while the panel is in executive session.

4. The panel shall not rescind the original vote without conducting a new hearing, except as provided in §505. L, §513.A.1-3, and §711.

5. The original vote sheet shall remain in the inmate's DOC file and a copy shall be attached to the minutes and maintained in a separate locked file in the committee office.

C. The chairperson of the panel shall appoint a member of each three-member panel, other than the chair, to review case records subsequent to voting to assure the accuracy of all documents.

D. A majority vote is required to continue or recess a meeting or hearing. Generally, the matter will be rescheduled for the next month, but may be rescheduled for an earlier date if deemed appropriate by the panel (see §514, "Voting/Votes Required").

E. A panel may go into executive session to discuss each offender's case prior to a decision pursuant to the provisions of R.S. 42:6, 42:6.1 and 15:574.12. No vote shall be taken while the panel is in executive session.

F. The committee may extend invitations to individuals to observe committee proceedings.

G. The committee may direct questions to and/or request statements from anyone appearing before the committee.

H. It is generally inappropriate for children under the age of 12 years, except when the child is a victim and chooses to appear, to be present during any public meeting or hearing of the committee.

I. The number of people supporting or opposing the granting of parole, including victims and/or family members of victims will be limited only by space and security considerations.

J. The vice chairman shall be responsible for schedules of administrative meetings and public hearings.

1. Such schedules may be changed, only upon prior notice, provided that such changes are made in a timely manner in order to notify all concerned.

2. Such meetings may be rescheduled without notice due to inclement weather, or any other emergency or unforeseen situation.

K. The vice-chairman of the committee or his or her designee shall develop a duty calendar and shall designate one committee member as the daily duty officer.

1. The duty officer shall be available and present to act on behalf of the committee concerning both routine office and administrative matters as authorized by these rules.

2. If the duty officer must substitute for another member at a hearing or is absent for any other reason, he or she need not be replaced by another duty officer.

L. Upon notification by the Secretary of the Department of Public Safety and Corrections that an offender has violated the terms of work release granted under §311 or has engaged in misconduct prior to the inmate's release, the committee may rescind its decision to grant parole. In such cases, the inmate shall promptly receive another parole hearing.

AUTHORITY NOTE: Promulgated in accordance with R.S. 15:574.2 et seq., R.S. 15:535 et seq., and R.S. 15:540 et seq.

HISTORICAL NOTE: Promulgated by the Department of Public Safety and Corrections, Board of Parole, LR 24:2298 (December 1998), amended by the Department of Public Safety and Corrections, Board of Pardons, Committee on Parole, LR 38:

§507. Business Meetings

A. The full committee shall meet as necessary when called by the chairman of the board. Additional meetings may be called a majority vote of the committee.

B. The agenda for business meetings of the committee may include, but shall not be limited to, the following topics:

1. committee rules;
2. personnel matters;
3. litigation; and
4. any other matters the committee deems necessary.

C. Business meetings should be tape recorded and copies of the taped and/or written minutes shall be available upon request.

AUTHORITY NOTE: Promulgated in accordance with R.S. 15:574.2 et seq., R.S. 15:535 et seq., and R.S. 15:540 et seq.

HISTORICAL NOTE: Promulgated by the Department of Public Safety and Corrections, Board of Parole, LR 24:2299 (December 1998), amended by the Department of Public Safety and Corrections, Board of Pardons, Committee on Parole, LR 38:

§509. Administrative Meetings

Repealed.

AUTHORITY NOTE: Promulgated in accordance with R.S. 15:574.2 et seq., R.S. 15:535 et seq., and R.S. 15:540 et seq.

HISTORICAL NOTE: Promulgated by the Department of Public Safety and Corrections, Board of Parole, LR 24:2299 (December 1998), repealed by the Department of Public Safety and Corrections, Board of Pardons, Committee on Parole, LR 38:

§510. Victims

A. Before a parole panel considers parole release for an offender who is serving a sentence of an offense in which a person was a victim, the parole panel shall allow one person to appear in person before the panel to present a statement of the person's views about the offense, the offender, and the effect of the offense on the victim. Nothing in this rule is intended to limit the panel's discretion to allow individual victims to make personal appearance or to make contact by phone through the local district attorney's victim advocacy representative.

B. The victim, spouse, or next of kin of a deceased victim shall be advised in writing no less than 30 days prior to the hearing date when the inmate is scheduled for a parole hearing.

C. The notice shall advise the victim, spouse, or next of kin of a deceased victim that:

1. the hearing is open to the public;
2. he or she may remain in the hearing room during the entire hearing (except during executive session); and
3. he or she may speak to the panel prior to its making a decision in the case.

D. The Committee on Parole has delegated the responsibility for this notice to the Department of Public Safety and Corrections.

E. The written notice is not required when the victim, the spouse, or next of kin of a deceased victim, advises the committee in writing that such notification is not desired.

F. Notification is not required when the victim cannot be located despite the exercise of due diligence.

G. For purposes of §509.A, a *victim* is defined as an individual against whom a crime has been perpetrated.

H. Pursuant to R.S. 15:574.2(C)(12) the panel may exclude anyone from the hearing to protect the privacy of the victim or victims.

I. The victim, the guardian of the victim, or close relative of a deceased victim shall have the right to make a written or oral statement as to the impact of the crime.

J. The victim, the guardian of the victim, or close relative of a deceased victim or a victim's advocacy group, and the district attorney or his representative may also appear before the panel by means of telephone communication from the office of the local district attorney.

AUTHORITY NOTE: Promulgated in accordance with R.S. 15:574.2 et seq., R.S. 15:535 et seq., and R.S. 15:540 et seq.

HISTORICAL NOTE: Promulgated by the Department of Public Safety and Corrections, Board of Pardons, Committee on Parole, LR 38:

§511. Public Hearings/Videoconferencing

A. The vice-chairman shall schedule public hearings. A copy of the schedule shall be available for public inspection at the committee office.

B.1. The panel may consider the following actions with the offender present:

- a. parole;
- i. in the case of IMPACT parole, the offender need not be present unless requested by the panel;
- b. revocation; and
- c. recommendations for work release.

2. The panel may consider the following actions without the offender present:

- a. to consider rehearing requests; and
- b. to consider those matters referred by a member from single-member action (see §513, "Single Member Action"); the member who makes such a referral may not serve on the panel.

C. Generally, public hearings shall be conducted via videoconferencing, with the committee members participating from the committee's headquarters in Baton Rouge, and offenders appearing before the committee via videoconferencing at the designated prison facility.

1. In the event a medical parole is being considered and the offender is unable to appear via videoconferencing, the committee shall travel to the prison facility at which the offender is housed to conduct the hearing.

2. In the case of videoconferencing, the family, friends, and attorney of the offender shall be at the location of the offender.

3. In the case of videoconferencing, the victim(s) may be at the location of the committee.

AUTHORITY NOTE: Promulgated in accordance with R.S. 15:574.2 et seq., R.S. 15:535 et seq. and R.S. 15:540 et seq.

HISTORICAL NOTE: Promulgated by the Department of Public Safety and Corrections, Board of Parole, LR 24:2299 (December 1998), amended LR 28:1597 (July 2002), amended by the Department of Public Safety and Corrections, Corrections Services, LR 36:2872 (December 2010). amended by the Department of Public Safety and Corrections, Board of Pardons, Committee on Parole, LR 38:

§513. Single-Member Action

A.1. A single committee member may act upon the following matters which have been reviewed and recommended by the Division of Probation and Parole:

- a. activity reports (see §1103); and
- b. violation reports (see §1109);
- c. activity and/or violation reports from other states via the interstate compact agreement.

2. A single committee member may also review the file of those offenders who have a parole eligibility date but who are ineligible for release, including offenders whose parole eligibility hearing date falls within 90 days of the offender's release on diminution of sentence/parole supervision.

3. The duty officer may rescind parole as provided in §505.L, pending another parole hearing.

4. The duty officer may add or remove conditions relative to parolees, as recommended by the Division of Probation and Parole and/or committee counsel on matters in litigation.

a. In the event the committee member fails to follow the recommendation of the Division of Probation and Parole, the matter shall be automatically scheduled for consideration by a three-member panel at the next available public hearing date.

B. Written documentation must be placed in the offender's file which clearly documents the reason for the decision by the single member panel.

C. Under no circumstances should a committee member sign a blank form concerning single-member action matters.

AUTHORITY NOTE: Promulgated in accordance with R.S. 15:574.2 et seq., R.S. 15:535 et seq., and R.S. 15:540 et seq.

HISTORICAL NOTE: Promulgated by the Department of Public Safety and Corrections, Board of Parole, LR 24:2300 (December 1998), amended by the Department of Public Safety and Corrections, Board of Pardons, Committee on Parole, LR 38:

§514. Voting/Votes Required

A. Unanimous Vote

1. A unanimous vote is required to grant parole or to recommend work release regardless of the number of committee members at the parole hearing, except as provided for in Subparagraph 2 of this Subsection.

2. Notwithstanding any other provision of law, no person convicted of a crime of violence against any peace officer as defined in R.S. 14:30(B), shall be granted parole except after a meeting, duly noticed and held on a date to be determined by the chairman, at which at least five of the seven members of the committee are present and all members present vote to grant parole.

3. A unanimous vote is required to consider any action when the offender is not present as described in §511.B.2.b or §513.A.4.a.

4. All special conditions of release, including special conditions of diminution of sentence/parole supervision release, shall be approved by a unanimous vote of the panel.

B. Majority Vote

1. The committee may grant parole with two votes of a three-member panel, or, if the number exceeds a three-member panel, a majority vote of those present if all of the following conditions are met.

a. The offender has not been convicted of a crime of violence as defined in R.S. 14:2(B) or a sex offense as defined in R.S. 15:541, or convicted of an offense which would constitute a crime of violence as defined in R.S. 14:2(B) or a sex offense as defined in R.S. 15:541, regardless of the date of conviction.

b. The offender has not committed any disciplinary offenses in the 12 consecutive months prior to the parole eligibility date.

i. If the offender's period of incarceration is less than 12 months, the offender must not have committed any disciplinary offenses during his/her entire period of incarceration.

c. The offender has completed the mandatory minimum of 100 hours of pre-release programming in accordance with R.S. 15:827.1.

d. The offender has completed substance abuse treatment as applicable.

e. The offender has obtained a GED credential, unless the offender has previously obtained a high school diploma or is deemed by a certified educator as being incapable of obtaining a GED credential due to a learning disability. If the offender is deemed incapable of obtaining a GED credential, the offender must complete at least one of the following:

- i. a literacy program;
- ii. an adult basic education program; or
- iii. a job skills training program.

f. The offender has obtained a low-risk level designation determined by a validated risk assessment instrument approved by the Secretary of the Department of Public Safety and Corrections.

2. A majority vote is required to revoke parole.

3. A majority vote is required to continue or recess a meeting or hearing.

4. A majority vote is required to grant an offender's request for a rehearing.

5. A majority vote is required for executive session.

C. Once the panel votes to grant or deny parole at a particular hearing, the vote may not be rescinded at that hearing.

D. If a member of a panel moves that a particular condition of parole be considered and determined prior to the vote to grant or deny parole, that issue shall be determined prior to the vote on parole. Otherwise, following a vote granting parole, the panel shall consider whether to impose special conditions of release.

E. The ex-officio member of the committee is a non-voting member.

AUTHORITY NOTE: Promulgated in accordance with R.S. 15:574.2 et seq., R.S. 15:535 et seq., and R.S. 15:540 et seq.

HISTORICAL NOTE: Promulgated by the Department of Public Safety and Corrections, Board of Pardons, Committee on Parole, LR 38:

Chapter 7. Parole Decisions

§701. Policy Statement

A. It shall be the policy of the committee to give every offender meaningful consideration for parole. The committee will exercise its discretionary releasing authority based upon consideration of the unique factors and variables of the individual case. The committee shall determine release suitability of eligible offenders through decisions that promote fairness, objectivity, and public safety and are responsive to the concerns of victims, members of the community, and other persons within the criminal justice system.

B. The committee shall consider all pertinent information (pre-parole investigation and institutional record) at least six months prior to the offender's parole

eligibility date. The information shall be a part of the offender's consolidated summary record. At a minimum, a pre-parole investigation shall be made available to the panel for its review. No case may be considered for parole release without a pre-parole investigation.

C. The panel shall apply the following guidelines as a basis, but not as the exclusive criteria, upon which parole panels base parole release decisions.

1. Nature and Circumstances of the Crime

a. The committee will evaluate and consider the circumstances of the crime based upon the official version of the offense, as well as the victim's and offender's versions of the offense, to determine, if possible, whether the particular conditions that contributed to the commission of the crime are likely to reoccur.

b. The committee shall also consider the seriousness of the offense, the offender's role in the offense and the degree of his involvement, whether the offender was the instigator of the crime, and whether the crime was premeditated.

c. Particular consideration will be given to those cases which involved the use of a weapon and/or caused injury to the victim; where the offender committed one or more violent acts indicating a conscious disregard for the lives, safety, or property of others; or the instant offense has elements of brutality, violence, or conscious selection of victim's vulnerability such that the offender poses a continuing threat to public safety.

2. Prior Criminal Record

a. The committee will evaluate and consider any available prior adult and/or juvenile records and the number and seriousness of prior convictions including the length of time between any prior convictions and the commitment of the instant offense to determine the seriousness of the offender's prior criminal history.

b. A pattern of repeated criminal episodes or a pattern of similar offenses may indicate a predisposition to commit criminal acts upon release and the likelihood that the offender will not succeed on parole.

c. The committee may also consider whether the instant offense was committed while the offender was on probation or parole, and the offender's response to prior community supervision, if any.

3. Character, Social Background, and Emotional and Physical Condition

a. The committee will evaluate and consider information pertaining to the offender's work record, level of education, occupational skills, and evidence of emotional stability.

b. A history of chronic drug and alcohol abuse may evidence the likelihood that the offender will not succeed on parole.

4. Institutional Adjustment

a. The committee will evaluate and consider information concerning the offender's attitude while incarcerated, including the offender's participation in available programs and his overall compliance with institutional regulations.

b. Obedience to institutional rules may evidence that the offender will comply with parole conditions, while a disciplinary record consisting of major and/or minor infractions may be viewed negatively.

c. Offenders assigned to working cellblock or disciplinary detention/extended lockdown or otherwise assigned to cellblock areas for disciplinary reasons would generally not be considered a good risk for early release and will, therefore, be ineligible for parole consideration until such time as the offender has not been in lockdown status for a period of six months.

5. Police, Judicial and Community Attitudes toward the Offender

a. The committee will evaluate and consider information concerning the offender from the community and public officials who are acquainted with the case.

b. This factor is given greater weight because the probability that an offender will succeed on parole is greatly diminished if he will return to a community which has expressed hostility toward him and is lacking support for him.

c. Evidence of official and/or community support may increase the likelihood of parole.

6. Parole Plan

a. The committee will evaluate and consider the strength of the offender's social ties, including whether he has a supportive family, resources available to him in the community, and employment opportunities.

b. The committee will place emphasis on the appropriateness of the parole plan; therefore, it is important for the offender to have secure employment plans and a stable living arrangement available upon parole.

c. Lack of an acceptable parole plan may decrease the likelihood of parole.

7. Program Participation. The committee will evaluate and consider an offender's participation in vocational training, adult education, or reading programs as well any treatment or rehabilitation program that has been certified by the department. Such participation is considered beneficial.

8. Risk Assessment

a. All Offenders. The committee will consider the risk assessment score provided by the Department of Public Safety and Corrections. The score is determined by a validated risk assessment instrument that has been validated for the Louisiana offender population. The assessment identifies potential risk and identifies programmatic needs of offenders. The assessment is conducted utilizing two sets of components, static and dynamic factors.

i. Static factors include:

- (a). age at first arrest;
- (b). history of revocations;
- (c). history of mental health problems;
- (d). employment history;
- (e). type of criminal record;
- (f). history of drug/alcohol abuse; and
- (g). number of felony convictions.

ii. Dynamic factors include:

- (a). the offender's current age;
- (b). whether the offender is a confirmed security threat group (gang) member;
- (c). educational, vocational, or other certified treatment and rehabilitation programs completed during the present incarceration;
- (d). prison disciplinary conduct;

- (e). current prison custody level; and
- (f). current mental health status.

b. Sex Offenders. The committee shall consider the actuarial risk assessment for sex offenders that has been adopted by the department. The use of this risk assessment is intended to be a measure of long-term risk potential. The committee shall consider reports, assessments, and clinical information, as available, including any testing and recommendations by mental health professionals, as to whether the offender has actively participated in a sex offender treatment program; and whether, in the expert's opinion, there is a likelihood that the offender will or will not repeat the criminal conduct and that the offender will or will not be a danger to society.

c. No offender may be paroled while there is pending against him any indictment or information for any crime suspected of having been committed by him while a prisoner.

d. The use of these assessments does not imply the creation of any parole release formula, or a right or expectation by an offender to parole based upon the guidelines. The assessments are not to be construed so as to mandate either a favorable or unfavorable parole decision. The assessments serve as an aid in the parole decision process and the parole decision shall be at the discretion of the voting parole panel.

AUTHORITY NOTE: Promulgated in accordance with R.S. 15:574.2 et seq., R.S. 15:535 et seq., and R.S. 15:540 et seq.

HISTORICAL NOTE: Promulgated by the Department of Public Safety and Corrections, Board of Parole, LR 24:2300 (December 1998), amended by the Department of Public Safety and Corrections, Board of Pardons, Committee on Parole, LR 38:

§703. Result of Decision to Grant or Deny Parole

A. The committee's decision to grant or deny parole will be made and disclosed to the offender at the time of the parole hearing and he will be furnished with a copy of the Parole Decision Form. The Parole Decision Form shall also be made available to the administration at the facility housing the offender.

1. The original Parole Decision Form will be placed in the offender's DOC record and will serve as the authority for the Certificate of Parole to be prepared.

2. The certificate will then be forwarded to the Division of Probation and Parole District Office where the offender will be supervised while on parole.

B. No physical release from custody shall be authorized by the granting of a parole eligibility date that extends beyond six months from the date of the hearing; nor shall release be authorized until all notice requirements, if any, have been timely made.

AUTHORITY NOTE: Promulgated in accordance with R.S. 15:574.2 et seq., R.S. 15:535 et seq., and R.S. 15:540 et seq.

HISTORICAL NOTE: Promulgated by the Department of Public Safety and Corrections, Board of Parole, LR 24:2301 (December 1998), amended by the Department of Public Safety and Corrections, Board of Pardons, Committee on Parole, LR 38:

§705. Application for Parole Rehearing

A. An offender must apply in writing for a parole rehearing. The written request must contain the following information (at a minimum):

1. name/DOC#;

2. current housing location:
 - a. name of facility;
 - b. custody status;
 - c. whether or not offender is currently in disciplinary lockdown;
3. date of last parole hearing;
4. conduct reports:
 - a. total reports;
 - b. date of last report;
5. self help program participation, including educational or other programs;
6. physical or psychological problems and treatment received, if any;
7. job plan/residence plan;
8. final comments (any other comments the offender wishes the committee to consider when reviewing the request for rehearing).

B. The written request for rehearing may be submitted by the offender and/or his attorney.

C. Application for a parole rehearing will be allowed only under the following conditions.

1. The offender must not have had a major (Schedule B) disciplinary misconduct report in the six months prior to the reapplication request;
2. The offender must not have been in disciplinary lockdown status for a period of six months prior to the reapplication request.
3. If both criteria in §705.C.1 and 2 are met, an offender may apply to the committee for a rehearing at the following intervals.

Type of Crime	Initial Request for Rehearing	Subsequent request for Rehearing ¹
Nonviolent, except as otherwise restricted	6 mos after original date of denial	6 mos after date of initial reapplication
Crime of Violence enumerated in R.S. 14:2(B)	1 yr after original date of denial	Every 2 yrs after date of initial reapplication
Crime Against Person enumerated in R.S. 14:29-47	1 yr after original date of denial	Every 2 yrs after date of initial reapplication
Sex Offense as defined in §903	2 yrs after original date of denial	Every 2 yrs after date of initial reapplication
Murder, 1st or 2nd degree	2 yrs after original date of denial	Every 2 yrs after date of initial reapplication
Manslaughter	2 yrs after original date of denial	Every 2 yrs after date of initial reapplication

¹Subsequent request for Rehearing may be submitted if initial request for rehearing was denied.

AUTHORITY NOTE: Promulgated in accordance with R.S. 15:574.2 et seq., R.S. 15:535 et seq., and R.S. 15:540 et seq.

HISTORICAL NOTE: Promulgated by the Department of Public Safety and Corrections, Board of Parole, LR 24:2301 (December 1998), amended by the Department of Public Safety and Corrections, Board of Pardons, Committee on Parole, LR 38:

§707. Parole Plans

A. In order for an offender to be considered for parole release, the offender must have a viable transition plan that includes housing, potential job opportunities, and a support network that can incorporate family, friends, church and rehabilitative programs. The plans for housing and

employment will be investigated and approved by the Division of Probation and Parole.

B. In-State Parole

1. The committee will not issue a Certificate of Parole to anyone granted parole until the residence plan has been approved by the Division of Probation and Parole. The committee has authority to waive employment plans for a specified amount of time. These plans should be given to the classification officer at the correctional facility at the pre-parole interview or mailed directly to the committee four months prior to the parole eligibility date.

2. A parole hearing may be held as docketed without approved residence or employment plans. Parole may be granted at the hearing, subject to the plans being approved through the Division of Probation and Parole. Approved employment plans may enhance the possibility for a favorable parole decision.

C. Out-of-State Parole

1. Out-of-state parole plans may be considered when the state in question issues a written statement expressing its willingness to accept the parolee under specific residential and employment conditions. Release will be deferred until such approval is received by the committee.

2. Before any parolee can be considered for a plan of supervision in another state, the offender shall sign an Application for Interstate Compact Services Agreement to Return (waiver of extradition).

AUTHORITY NOTE: Promulgated in accordance with R.S. 15:574.2 et seq., R.S. 15:535 et seq., and R.S. 15:540 et seq.

HISTORICAL NOTE: Promulgated by the Department of Public Safety and Corrections, Board of Parole, LR 24:2301 (December 1998), amended by the Department of Public Safety and Corrections, Board of Pardons, Committee on Parole, LR 38:

§709. Parole to Detainer

A. When the committee determines that it would be in the best interest of the public and the inmate, parole may be granted subject to any outstanding detainers or notices that are held by local and/or immigration authorities. Once the parolee is released from the detaining authority, he must report to the Division of Probation and Parole District Office where he will be supervised while on parole.

AUTHORITY NOTE: Promulgated in accordance with R.S. 15:574.2 et seq., R.S. 15:535 et seq., and R.S. 15:540 et seq.

HISTORICAL NOTE: Promulgated by the Department of Public Safety and Corrections, Board of Parole, LR 24:2301 (December 1998), amended by the Department of Public Safety and Corrections, Board of Pardons, Committee on Parole, LR 38:

§711. Conditional Parole

A. When the committee determines that it would be in the best interest of the public and the offender, the committee may require successful completion of a committee-approved program (i.e., substance abuse treatment, transitional work program, 100 hours of pre-release training, reentry program, attainment of GED) as a prerequisite to release on parole. The committee may specify which programs are committee-approved.

1. In no event, however, may the physical release from custody on parole extend beyond six months from the hearing date.

2. If the offender has not successfully completed the program in six months from the hearing date, the committee shall rescind or reconsider his parole and schedule a subsequent hearing.

AUTHORITY NOTE: Promulgated in accordance with R.S. 15:574.2 et seq., R.S. 15:535 et seq., and R.S. 15:540 et seq.

HISTORICAL NOTE: Promulgated by the Department of Public Safety and Corrections, Board of Parole, LR 24:2301 (December 1998), amended by the Department of Public Safety and Corrections, Board of Pardons, Committee on Parole, LR 38:

Chapter 9. Conditions of Parole

§901. Certificate of Parole

A. The Certificate of Parole will not become operative until specific conditions of release have been acknowledged and agreed to in writing by the offender.

1. The offender shall be advised orally and in writing of the conditions of parole prior to his release from incarceration.

2. The conditions of parole shall include, but not be limited to, those conditions contained in the Certificate of Parole, as approved by the committee and the Division of Probation and Parole pursuant to the provisions of R.S. 15:574.4

B. Special conditions of parole, in addition to those required by R.S. 15:574.4 may be imposed and may include one or more of the following:

1. attendance at AA/NA meetings (the committee may specify the number of meetings to attend weekly);
2. mental health evaluation and treatment;
3. substance abuse evaluation and treatment;
4. payment of restitution for a direct pecuniary loss other than damage to or loss of property;
5. payment of fines and/or costs of court;
6. prohibited contact with the victim(s);
7. prohibited contact with co-defendant(s);
8. required GED, vo-tech or other educational plan;
9. compliance with treatment plan as ordered in the mental health or substance abuse treatment provider;
10. any other special conditions the committee may deem appropriate.

C. The committee shall impose special conditions of parole as set forth below.

1. When the victim's loss consists of damage to or loss of property, payment of restitution, either in a lump sum amount or in monthly installments based on the offender's earning capacity and assets. If the victim has been paid for such damage to or loss of property with monies from the Crime Victims Reparations Fund, the committee shall order the parolee to make payments as reimbursement to the fund in the same amount as was paid from the fund to the victim. The Department of Public Safety and Corrections shall verify that prior payment has not been made by the parolee.

2. If the offender has not paid and is liable for any costs of court or costs of the prosecution or proceeding in which he was convicted or any fine imposed as a part of his sentence, the committee shall require the payment of such costs or fine, either in a lump sum or according to a schedule of payments established by the committee and based upon the offender's ability to pay.

3.a. If the offender does not have a high school degree or its equivalent, the committee shall require the offender to enroll in and attend an adult education or reading program until he obtains a GED, or until he completes such educational programs required by the committee, and has attained a sixth grade reading level, or until his term of parole expires, whichever occurs first. All costs shall be paid by the offender.

b. If it is determined that there are no adult education or reading programs in the parish in which the offender will be residing, or that the offender is unable to afford such a program, or attendance would create an undue hardship, this condition may be suspended.

c. The provisions of §901 shall not apply to those offenders who are mentally, physically, or by reason of age, infirmity, dyslexia, or other such learning disorders, unable to participate.

AUTHORITY NOTE: Promulgated in accordance with R.S. 15:574.2 et seq., R.S. 15:535 et seq., and R.S. 15:540 et seq.

HISTORICAL NOTE: Promulgated by the Department of Public Safety and Corrections, Board of Parole, LR 24:2302 (December 1998), amended by the Department of Public Safety and Corrections, Board of Pardons, Committee on Parole, LR 38:

§903. Sex Offenders; General

A. The term *sex offender* shall refer to an offender/parolee who has been convicted for the commission or attempted commission of any of the following offenses (R.S. 15:541(24), or the equivalent, if committed in another jurisdiction:

1. aggravated rape, forcible rape, simple rape;
2. sexual battery, aggravated sexual battery, oral sexual battery, aggravated oral sexual battery;
3. intentional exposure of AIDS virus;
4. bigamy, abetting in bigamy;
5. incest, aggravated incest;
6. carnal knowledge of a juvenile, indecent behavior with a juvenile, pornography involving a juvenile, molestation of a juvenile;
7. crime against nature; aggravated crime against nature; crime against nature, solicitation (solicitation of persons under 17);
8. contributing to the delinquency of juveniles by the performance of any sexual immoral act;
9. human trafficking, trafficking of children;
10. computer aided solicitation of a juvenile;
11. sexual battery of the infirm;
12. obscenity by solicitation (of a person under the age of 17); or
13. video voyeurism; voyeurism, second or subsequent offense.

B. - C. ...

AUTHORITY NOTE: Promulgated in accordance with R.S. 15:574.2 et seq., R.S. 15:535 et seq., and R.S. 15:540 et seq.

HISTORICAL NOTE: Promulgated by the Department of Public Safety and Corrections, Board of Parole, LR 24:2302 (December 1998), amended by the the Department of Public Safety and Corrections, Board of Pardons, Committee on Parole, LR 38:

§907. Additional Notification and Registration Requirements for Sex Offenders if Victim Is under Age 18

A. In addition to any other notification requirement imposed by law, within three days of its decision to release a sex offender whose victim was under 18 years of age at the time of the commission of the offense, the committee shall mail notice by registered or certified letter to the victim or the victim's parent or guardian if they were not present at the parole hearing, unless the victim or relative has signed a written waiver of notification, with a statement indicating:

1. that the sex offender will be released on parole;
2. the date the sex offender will be released; and
3. the address where the sex offender will reside.

B.1 - B.3. ...

AUTHORITY NOTE: Promulgated in accordance with R.S. 15:574.2 et seq., R.S. 15:535 et seq., and R.S. 15:540 et seq.

HISTORICAL NOTE: Promulgated by the Department of Public Safety and Corrections, Board of Parole, LR 24:2303 (December 1998), amended by the the Department of Public Safety and Corrections, Board of Pardons, Committee on Parole, LR 38:

§909. Special Conditions—Sex Offenders

A. In addition to the requirements and conditions as set forth in this Chapter, all sex offenders shall be subject to any special conditions as required by the committee including, but not limited to signs, handbills, bumper stickers, or clothing labeled to that effect.

AUTHORITY NOTE: Promulgated in accordance with R.S. 15:574.2 et seq., R.S. 15:535 et seq., and R.S. 15:540 et seq.

HISTORICAL NOTE: Promulgated by the Department of Public Safety and Corrections, Board of Parole, LR 24:2303 (December 1998), amended by the Department of Public Safety and Corrections, Board of Pardons, Committee on Parole, LR 38:

§911. Release of Information

Repealed.

AUTHORITY NOTE: Promulgated in accordance with R.S. 15:574.2 et seq., R.S. 15:535 et seq., and R.S. 15:540 et seq.

HISTORICAL NOTE: Promulgated by the Department of Public Safety and Corrections, Board of Parole, LR 24:2303 (December 1998), repealed by the Department of Public Safety and Corrections, Board of Pardons, Committee on Parole, LR 38:

Chapter 15. Parole Suspension and Termination

§1501. Suspension of Supervised Parole

A. After a minimum of 18 months supervised parole and upon the recommendation of the Division of Probation and Parole, the committee may determine that a parolee merits unsupervised parole and may suspend a parolee's supervision.

1. A parole officer may recommend that an offender be placed in suspended status if the offender meets the following criteria:

- a. completed a minimum of 18 months supervision;
- b. is a first or second felony offender;
- c. scored "minimum" on the LARNA;
- d. has completed all special conditions ordered by the sentencing judge and/or committee;
- e. has remained conviction free (excludes minor traffic and local municipal statutes) for the period of supervision and has no pending criminal matters;
- f. is a non DWI case;
- g. is free of any conviction, deferred adjudication withheld for a sex offense as defined is R.S. 15:541;
- h. is a current non-violent offender (a prior violent offense does not rule out the recommendation for suspended status if the current case meets eligibility requirements).

1. Exceptions to Subparagraph A.1.h:

- a. parole case with a current violent offense that has been on supervision for at least five years and has remained arrest free;
- b. parole case with a current violent offense with a medical or physical condition and is no longer considered a threat to public safety;
- c. parole case with a current violent offense who has been displaced to another state due to emergency

situation (i.e., hurricane or other natural disaster) and who do not have a residence plan in Louisiana.

B. A parolee in suspended status may be subject to revocation for parole violations committed prior to the expiration of his full term discharge date. The parolee may be returned to maximum supervision any time prior to the expiration of his full term discharge date if the Division of Probation and Parole makes a report showing that such supervision is in the interest of either the public or the parolee.

AUTHORITY NOTE: Promulgated in accordance with R.S. 15:574.2 et seq., R.S. 15:535 et seq., and R.S. 15:540 et seq.

HISTORICAL NOTE: Promulgated by the Department of Public Safety and Corrections, Board of Parole, LR 24:2307 (December 1998), amended by the Department of Public Safety and Corrections, Board of Pardons, Committee on Parole, LR 38:

§1503. Termination of Parole

A. When a parolee has completed his sentence, he will be given a Certificate of Discharge from the Department of Public Safety and Corrections. The committee cannot terminate parole prior to the parolee's full term discharge date.

AUTHORITY NOTE: Promulgated in accordance with R.S. 15:574.2 et seq., R.S. 15:535 et seq., and R.S. 15:540 et seq.

HISTORICAL NOTE: Promulgated by the Department of Public Safety and Corrections, Board of Parole, LR 24:2307 (December 1998), amended by the Department of Public Safety and Corrections, Board of Pardons, Committee on Parole, LR 38:

Family Impact Statement

These amendments have no known impact on family formation, stability or autonomy, as described in R.S. 49:972.

Public Comment

Written comments may be addressed to Linda Landry, Principal Assistant to the Committee on Parole, Post Office Box 94304, Baton Rouge, LA 70804 until 4:30 p.m. on November 8, 2012.

Sheryl M. Ranatza
Chairman

**FISCAL AND ECONOMIC IMPACT STATEMENT
FOR ADMINISTRATIVE RULES**

**RULE TITLE: Committee on Parole—Membership,
Duties, and Functions**

**I. ESTIMATED IMPLEMENTATION COSTS (SAVINGS) TO
STATE OR LOCAL GOVERNMENT UNITS (Summary)**

The proposed rule change will result in an annual savings of \$305,287 to the Department of Corrections by merging the Pardon and Parole Boards. Savings include a reduction of 5 Parole Board member's salaries and related benefits.

The proposed rule change updates and revises LAC 22:X1 due to the passage of Act 714 of the 2012 Regular Session. The act merges the functions and duties of the Board of Parole into the Board of Pardons, creates a committee on parole, and provides for the committee's membership, duties and functions.

**II. ESTIMATED EFFECT ON REVENUE COLLECTIONS OF STATE
OR LOCAL GOVERNMENTAL UNITS (Summary)**

There will be no effect on revenue collections of state or local governmental units as a result of the proposed rule change.

III. ESTIMATED COSTS AND/OR ECONOMIC BENEFITS TO DIRECTLY AFFECTED PERSONS OR NONGOVERNMENTAL GROUPS (Summary)

There is no estimated cost and/or economic benefit to directly affected persons or non-governmental groups as a result of the proposed rule change.

IV. ESTIMATED EFFECT ON COMPETITION AND EMPLOYMENT (Summary)

There is no estimated effect on competition and employment as a result of the proposed rule change.

Thomas C. Bickham, III
Undersecretary
1210#042

Evan Brasseaux
Staff Director
Legislative Fiscal Office

NOTICE OF INTENT

**Department of Public Safety and Corrections
Office of Motor Vehicles**

Veterans Driver's License (LAC 55:III.110)

In accordance with the provisions of R.S. 32:412, relative to the authority of the Office of Motor Vehicles, the Office of Motor Vehicles hereby proposes to adopt the following Rule regarding the establishment of requirements for a U.S. Veterans driver's license.

Title 55

PUBLIC SAFETY

Part III. Motor Vehicles

Chapter 1. Driver's License

Subchapter A. General Requirements

§110. U.S. Veterans Driver's License

A. A special Louisiana driver's license, regardless of its class, shall be issued to any veteran of the Armed Forces of the United States with the word "Veteran" exhibited in the color black below the person's photograph on the driver's license.

B. Eligibility. A qualified veteran shall include any veteran who has served 90 days military duty in a branch of the United States Armed Forces.

C. Requirements

1. All applications for veteran driver's license must be accompanied by a DD Form 214 or one of the following Department of Defense form 214 (DD_214) equivalents:

a. Pre DD 214 era documents (1941_1950):

i. WE AGO (War Department Adjutant General) Forms, to include WD AGO 53, WD AGO 55, WD AGO 53_55;

ii. JAVPERS (Naval Personnel) Discharge Documents, to include NAVPERS 553, NAVMC78PD, NAVCG 553.

b. National Personnel Records Center NPRC "Statement of Service," issued as a result of a destroyed discharge record during the 1973 National Archives fire.

c. National Guard/Air National Guard must have NGB_22 with 6 or more years of service.

2. The applicant must have received a Character of Service discharge that is either classified as "Honorable" or "Under Honorable Conditions (General)."

3. If the applicant is required to be registered as a sex offender pursuant to Chapter 3-B of Title 15, then the applicant shall not have the word "Veteran" displayed on the license as the words "Sex Offender" shall be displayed below the person's photograph on the driver's license.

D. Cancellation. If the owner of a veteran driver's license no longer wishes to display "Veteran" on the driver's license, the license shall be returned to the department for cancellation.

E. Fees. No additional fee shall be charged to include such a designation. The charge for a veteran driver's license shall be the same as for regular driver's license.

AUTHORITY NOTE: Promulgated in accordance with R.S. 32:412.

HISTORICAL NOTE: Promulgated by the Department of Public Safety and Corrections, Office of Motor Vehicles, LR 39:

Family Impact Statement

The proposed Rule will not have any known or foreseeable impact on any family as defined by R.S. 49:972(D) or on family formation, stability and autonomy. Specifically there should be no known or foreseeable effect on:

1. the stability of the family;
2. the authority and rights of parents regarding the education and supervision of their children;
3. the functioning of the family;
4. family earnings and family budget;
5. the behavior and personal responsibility of the children.

Local governmental entities have the ability to perform the enforcement of the action proposed in accordance with R.S. 40:1730.23.

Small Business Statement

The impact of the proposed Rule on small businesses has been considered and it is estimated that the proposed action is not expected to have a significant adverse impact on small businesses as defined in the Regulatory Flexibility Act. The agency, consistent with health, safety, environmental and economic welfare factors has considered and, where possible, utilized regulatory methods in the drafting of the proposed Rule that will accomplish the objectives of applicable statutes while minimizing the adverse impact of the proposed Rule on small businesses.

Public Comments

All interested persons are invited to submit written comments on the proposed regulation. Such comments should be submitted no later than November 16, 2012, at 4:30 p.m. to Stephen A. Quidd, P.O. Box 66614, Baton Rouge, LA 70896, (225) 925-6103.

Public Hearing

A public hearing is scheduled for November 17, 2012 at 10:00 a.m. at 7979 Independence Blvd., Baton Rouge, LA 70806. Please call in advance to confirm the time and place of meeting, as the meeting will be cancelled if the requisite number of comments is not received.

Jill P. Boudreaux
Undersecretary

**FISCAL AND ECONOMIC IMPACT STATEMENT
FOR ADMINISTRATIVE RULES**

RULE TITLE: Veterans Driver's License

I. ESTIMATED IMPLEMENTATION COSTS (SAVINGS) TO STATE OR LOCAL GOVERNMENT UNITS (Summary)

There are no anticipated implementation costs or material savings to state or local governmental units resulting from the proposed Rule. The proposed Rule implements the veteran designation on a driver's licenses and identification cards as provide in Act 356 of the 2012 Regular Session of the Louisiana Legislature.

II. ESTIMATED EFFECT ON REVENUE COLLECTIONS OF STATE OR LOCAL GOVERNMENTAL UNITS (Summary)

There is no anticipated effect on revenue collections for state or local governmental units as a result of this Rule change.

III. ESTIMATED COSTS AND/OR ECONOMIC BENEFITS TO DIRECTLY AFFECTED PERSONS OR NONGOVERNMENTAL GROUPS (Summary)

There is no anticipated effect on costs and/or economic benefits to directly affected persons or non-governmental groups as a result of this Rule change.

IV. ESTIMATED EFFECT ON COMPETITION AND EMPLOYMENT (Summary)

There is no anticipated effect on competition and/or employment as a result of this Rule change.

Jill P. Boudreaux
Undersecretary
1210#103

Evan Brasseaux
Staff Director
Legislative Fiscal Office

NOTICE OF INTENT

**Department of Revenue
Policy Services Division**

**Corporation Income and Franchise Tax Filing Extensions
(LAC 61:III.2503)**

Under the authority of R.S. 47:1511, 1514, 287.614(D), and in accordance with the provisions of the Administrative Procedure Act, R.S. 49:950 et seq., the Department of Revenue, Policy Services Division, proposes to amend LAC 61:III.2503, to mandate the electronic filing of a request for an extension to file a Corporation Income and Franchise Tax Return.

The secretary of revenue is authorized, but not required, to grant a reasonable extension of time to file a Louisiana Corporation Income and Franchise Tax Return. Beginning with returns due on April 15, 2013, corporate taxpayers needing additional time to file a Corporation Income and Franchise Tax Return must electronically submit a request for an extension of time to file on or before the return due date.

Corporate Income and Franchise Tax Returns for 2012 will be due April, 15 2013.

Title 61

REVENUE AND TAXATION

Part III. Administrative Provisions and Miscellaneous

Chapter 25. Returns

§2503. Corporation Income and Franchise Tax Filing Extensions

A. Louisiana Revised Statute Title 47, Section 287.614(D) provides that the secretary may grant a

reasonable extension of time to file a state corporation income and franchise tax return, not to exceed seven months, from the date the return is due.

1. To obtain a filing extension, the taxpayer must make the request on or before the tax return's due date.

2. A taxpayer must request a state filing extension by submitting an electronic application.

3. An electronic application may be submitted via:

a. the Department of Revenue's web site at www.revenue.louisiana.gov/extensions;

b. tax preparation software; or

c. any other electronic method authorized by the secretary.

B. Filing Extension Does Not Extend Time to Pay Tax

1. A filing extension granted by the secretary only allows for an extension of time to file the tax return. The extension does not allow an extension of time to pay the tax due.

2. To avoid interest and penalty assessments, income and franchise taxes due must be prepaid on or before the original due date.

AUTHORITY NOTE: Promulgated in accordance with R.S. 47:1511 and 287.614(D).

HISTORICAL NOTE: Promulgated by the Department of Revenue, Policy Services Division, LR 36:552 (March 2010), amended LR 39:

Family Impact Statement

The proposed amendment of LAC 61:III.2503, regarding Corporation Income and Franchise Tax Filing Extensions, should not have any known or foreseeable impact on any family as defined by R.S. 49:972(D) or on family formation, stability and autonomy. Specifically, the implementation of this proposed Rule will have no known or foreseeable effect on:

1. the stability of the family;
2. the authority and rights of parents regarding the education and supervision of their children;
3. the functioning of the family;
4. family earnings and family budget;
5. the behavior and personal responsibility of children;
6. the ability of the family or a local government to perform this function.

Public Comments

Any interested person may submit written data, views, arguments, or comments regarding this proposed Rule to Nina Hunter, Attorney, Policy Services Division, Office of Legal Affairs by mail to P.O. Box 44098, Baton Rouge, LA 70804-4098. All comments must be received no later than 5:00 p.m., Tuesday, November 27, 2012.

Public Hearing

A public hearing will be held on Wednesday, November 28, 2012, at 8:00 a.m. in the Pelican Room, on the seventh floor of the LaSalle Building, 617 North Third Street, Baton Rouge, Louisiana.

Tim Barfield
Executive Counsel

**FISCAL AND ECONOMIC IMPACT STATEMENT
FOR ADMINISTRATIVE RULES
RULE TITLE: Corporation Income and Franchise Tax
Filing Extensions**

**I. ESTIMATED IMPLEMENTATION COSTS (SAVINGS) TO
STATE OR LOCAL GOVERNMENT UNITS (Summary)**

The proposed amendment to this Rule mandates the electronic filing of requests for extensions to file corporation income and franchise tax returns for Tax Year 2012 and beyond. The electronic application already exists and there are no anticipated costs for implementation. The adoption of this amendment will allow the reallocation of resources being used to process paper extension requests to other tax processing functions.

Implementation of the proposed amendment to this Rule is expected to reduce the need for manual processing of paper extension requests which would allow the reallocation of resources to other areas necessary to fulfill the department's mission.

**II. ESTIMATED EFFECT ON REVENUE COLLECTIONS OF STATE
OR LOCAL GOVERNMENTAL UNITS (Summary)**

An electronic filing mandate for extensions to file corporation income and franchise tax returns will not alter the amount of tax due or collected, therefore it will have no effect on revenue collections of state or local governmental units. Extension requests are currently accepted by paper or electronically.

**III. ESTIMATED COSTS AND/OR ECONOMIC BENEFITS TO
DIRECTLY AFFECTED PERSONS OR NONGOVERNMENTAL
GROUPS (Summary)**

For the 2011 tax year, the last year in which state corporation income and franchise tax returns were filed, approximately 48,700 extensions were filed, of which approximately 26,550 or 55 percent were filed on paper and 22,150 or 45 percent were filed electronically. This proposed Rule limits the filing of extensions for corporation income and franchise tax returns to electronic means. Because many taxpayers already file extension requests electronically, and requests can be filed through the Louisiana Department of Revenue (LDR) web site for free, the cost to affected taxpayers is anticipated to be minimal. Also, taxpayers can obtain internet access to electronically file extensions at LDR offices and public libraries throughout the state. Taxpayers who file an extension through electronic means receive a notification of receipt which is an added benefit that paper filers did not receive.

**IV. ESTIMATED EFFECT ON COMPETITION AND EMPLOYMENT
(Summary)**

The proposed amendment to this Rule should not affect competition or employment.

Tim Barfield
Executive Counsel
1210#112

Gregory V. Albrecht
Chief Economist
Legislative Fiscal Office

NOTICE OF INTENT

**Department of Revenue
Policy Services Division**

Income and Franchise Tax (LAC 61:I.1520)

Under the authority of R.S.47:1511, R.S.47:164(D) R.S.47: 295 and R.S.47:114 and in accordance with the provisions of the Administrative Procedure Act, R.S.49:950 et seq., the Department of Revenue, Policy Services Division, proposes to amend LAC 61.I.1520.

Pursuant to Act 107 of the 2012 Regular Legislative Session relative to Returns and Payment of tax, this proposed amendment makes the regulation consistent with statute which provides that withholding returns are to be filed on a quarterly basis.

Title 61

REVENUE AND TAXATION

**Part I. Taxes Collected and Administered by the
Secretary of Revenue**

Chapter 15. Income: Withholding Tax

§1520. Withholding by Professional Athletic Teams

A. - C. ...

D. Due Date of Withholding Return and Payment. A withholding payment must be submitted for each game played in Louisiana. The payment must be submitted on or before the last day of the month following the month in which the game was played. A withholding return must be submitted for each quarter in which a game was played in Louisiana to reconcile all payments made within that quarter. The withholding return must be submitted quarterly on or before the last day of the month following the quarter in which the game was played.

E. - F. ...

AUTHORITY NOTE: Adopted in accordance with R.S. 39:100.1, R.S. 47:164(D), R.S. 47:295, R.S. 47:1511, R.S. 47: 114 and R.S. 47:1602.1.

HISTORICAL NOTE: Promulgated by the Department of Revenue, Policy Services Division, LR 30:91 (January 2004), amended LR 39:

Family Impact Statement

The proposed amendment of LAC 61:III.1520, regarding individual withholding by professional athletic teams, should not have any known or foreseeable impact on any family as defined by R.S. 49:972(D) or on family formation, stability and autonomy. Specifically, the implementation of this proposed Rule will have no known or foreseeable effect on:

1. the stability of the family;
2. the authority and rights of parents regarding the education and supervision of their children;
3. the functioning of the family;
4. family earnings and family budget;
5. the behavior and personal responsibility of children;
6. the ability of the family or a local government to perform this function.

Public Comment

Interested persons may submit written data, views, arguments, or comments regarding this proposed Rule to the Policy Services Division, by mail to P.O. Box 44098, Baton Rouge, LA 70804-4098 or by fax to (225) 219-2759. All comments must be received no later than 5:00 p.m., November 28, 2012

Public Hearing

A public hearing will be held on November 29, 2012 at 11:00 a.m. in the River Room, on the seventh floor of the LaSalle Building, 617 North Third Street, Baton Rouge, LA 70802.

Tim Barfield
Executive Counsel

**FISCAL AND ECONOMIC IMPACT STATEMENT
FOR ADMINISTRATIVE RULES**

RULE TITLE: Income and Franchise Tax

I. ESTIMATED IMPLEMENTATION COSTS (SAVINGS) TO STATE OR LOCAL GOVERNMENT UNITS (Summary)

For professional athletic teams, this proposal amends the withholding tax Rule that relates to the frequency of return filing by changing filing deadlines from monthly to quarterly. Payments must continue to be submitted monthly. This proposal changes the requirement of a monthly return for each month in which a game is played in Louisiana, to a quarterly return for each quarter in which a game is played in Louisiana. This amendment is one of many changes in the withholding reporting and remittance model for all Louisiana employers per Act 107 of 2012 Regular Session. Beginning with taxes withheld on or after January 1, 2012, all employers, including professional athletic teams, will be required to submit quarterly withholding returns reconciling the amount of taxes remitted during the calendar quarter to the amounts withheld during the quarter. Implementation costs of changing the entire withholding model include form changes, costs to inform employers of reporting changes, and computer system development and modification. Computer system implementation costs were approximately \$625,000, and the other costs were minimal. Implementation costs were absorbed in the existing budget.

Local governmental units are not affected by this proposal.

II. ESTIMATED EFFECT ON REVENUE COLLECTIONS OF STATE OR LOCAL GOVERNMENTAL UNITS (Summary)

This proposal only affects the frequency of return filing, not the amount of tax that is imposed. Therefore, this proposal should have no impact on the revenue collections of state or local governmental units.

III. ESTIMATED COSTS AND/OR ECONOMIC BENEFITS TO DIRECTLY AFFECTED PERSONS OR NONGOVERNMENTAL GROUPS (Summary)

Persons affected by this Rule are professional athletic teams that play games in Louisiana. These taxpayers will be required to file fewer returns under this proposal because they will only be required to file returns quarterly instead of monthly, though payments will continue to be filed monthly. Costs to these employers are expected to be minimal.

IV. ESTIMATED EFFECT ON COMPETITION AND EMPLOYMENT (Summary)

This proposal should not affect competition or employment.

Tim Barfield
Executive Counsel
1210#110

Gregory V. Albrecht
Chief Economist
Legislative Fiscal Office

NOTICE OF INTENT

**Department of Revenue
Policy Services Division**

Income—Withholding Tax (LAC 61:I.1516)

Under the authority of R.S.47:1511, R.S.47:1519, and R.S.47:114 and in accordance with the provisions of the Administrative Procedure Act, R.S.49:950 et seq., the Department of Revenue, Policy Services Division, proposes to adopt LAC 61.I.1516.

Pursuant to Act 107 of the 2012 Regular Legislative Session relative to Returns and Payment of tax, this

proposed Rule provides for payment and due dates for payment of tax by every employer or person who deducts and withholds any amount from any wage as required by Louisiana law.

Title 61

REVENUE AND TAXATION

Part I. Taxes Collected and Administered by the

Secretary of Revenue

Chapter 15. Income—Withholding Tax

§1516. Payment

A. All employers or persons who deduct and withhold any amount from any wage pursuant to R.S. 47:114 shall remit payment on a quarterly basis.

B. The due dates for quarterly payments are:

1. first quarter—April 30;
2. second quarter—July 31;
3. third quarter—October 31;
4. fourth quarter—January 31.

C. Exceptions

1. When the amount deducted or withheld within any calendar month from the combined wages of all employees is an amount equal to or greater than \$500.00 but less than \$5,000.00, the taxes withheld shall be paid monthly. Payment is due on the last day of the month following the close of the monthly period.

2. When the amount deducted or withheld within any calendar month from the combined wages of all employees is an amount equal to or greater than \$5,000.00, the taxes withheld shall be paid semimonthly. For wages paid during the first 15 days of a calendar month, the due date is the last calendar day of that month. For wages paid between the sixteenth day and the last day of a calendar month, the due date is the fifteenth day of the following month.

AUTHORITY NOTE: Promulgated in accordance with R.S. 47:114, R.S. 47:1511, R.S. 47:1519, and R.S. 47:1520.

HISTORICAL NOTE: Promulgated by the Louisiana Department of Revenue, Policy Services Division, LR 39:

Family Impact Statement

The proposed adoption of LAC 61:III.1516, regarding individual income tax withholding, should not have any known or foreseeable impact on any family as defined by R.S. 49:972(D) or on family formation, stability and autonomy. Specifically, the implementation of this proposed Rule will have no known or foreseeable effect on:

1. the stability of the family;
2. the authority and rights of parents regarding the education and supervision of their children;
3. the functioning of the family;
4. family earnings and family budget;
5. the behavior and personal responsibility of children;
6. the ability of the family or a local government to perform this function.

Public Comments

Interested persons may submit written data, views, arguments, or comments regarding this proposed Rule to the Policy Services Division, by mail to P.O. Box 44098, Baton Rouge, LA 70804-4098 or by fax to (225) 219-2759. All comments must be received no later than 5:00 p.m., November 27, 2012.

Public Hearing

A public hearing will be held on November 28, 2012 at 9 a.m. in the River Room, on the seventh floor of the LaSalle Building, 617 North Third Street, Baton Rouge, LA 70802.

Tim Barfield
Executive Counsel

FISCAL AND ECONOMIC IMPACT STATEMENT FOR ADMINISTRATIVE RULES

RULE TITLE: **Income—Withholding Tax**

I. ESTIMATED IMPLEMENTATION COSTS (SAVINGS) TO STATE OR LOCAL GOVERNMENT UNITS (Summary)

Act 107 of the 2012 Regular Legislative Session deleted payment due dates from R.S. 47:114 and provided that payments shall be made as prescribed by the secretary of the Department of Revenue. The proposed Rule provides that taxpayers that withhold \$500 or less per month shall remit payments quarterly, taxpayers that withhold greater than \$500 but less than \$5,000 per month shall remit payments monthly, and taxpayers that withhold greater than \$5,000 per month shall remit payments semi-monthly. The withholding reporting and remittance model was changed for all withholding taxpayers beginning with taxes withheld on or after January 1, 2012. Payment frequency requirements were changed in the new model for those taxpayers who withheld between \$2,000 and less than \$5,000 during any calendar month, who would now be allowed to pay monthly instead of semi-monthly. Implementation costs of changing the entire withholding model include form changes, costs to inform employers of reporting changes and remittance frequency changes, and computer system development and modification. Computer system implementation costs were approximately \$625,000, and the other costs were minimal. Implementation costs were absorbed in the existing budget.

Local governmental units are not affected by this proposal.

II. ESTIMATED EFFECT ON REVENUE COLLECTIONS OF STATE OR LOCAL GOVERNMENTAL UNITS (Summary)

This proposal only affects the frequency of payments, not the amount of tax that is imposed. Therefore, this proposal should have no impact on the revenue collections of state or local governmental units.

III. ESTIMATED COSTS AND/OR ECONOMIC BENEFITS TO DIRECTLY AFFECTED PERSONS OR NONGOVERNMENTAL GROUPS (Summary)

Persons affected by this Rule are taxpayers who withheld between \$2,000 and less than \$5,000 during any calendar month. These taxpayers will be required to make fewer payments under this Rule. Costs to these employers are expected to be minimal.

IV. ESTIMATED EFFECT ON COMPETITION AND EMPLOYMENT (Summary)

This proposed Rule should not affect competition or employment.

Tim Barfield
Executive Counsel
1210#109

Gregory V. Albrecht
Chief Economist
Legislative Fiscal Office

NOTICE OF INTENT

Department of Revenue Policy Services Division

Individual Income Tax Filing Extensions
(LAC 61:III.2501)

Under the authority of R.S. 47:1511, 1514, 103(D), and in accordance with the provisions of the Administrative Procedure Act, R.S. 49:950 et seq., the Department of Revenue, Policy Services Division, proposes to amend LAC 61:III.2501 to mandate the electronic filing of a request for an extension to file an individual income tax return.

The secretary of revenue is authorized, but not required, to grant a reasonable extension of time to file a Louisiana individual income tax return. Beginning with returns due on or after May 15, 2013, individuals needing additional time to file their income tax returns must electronically request an extension of time to file on or before the return due date. Individual income tax returns for 2012 will be due May 15, 2013.

Title 61

REVENUE AND TAXATION

Part III. Administrative Provisions and Miscellaneous Chapter 25. Returns

§2501. Individual Income Tax Filing Extensions

A. Louisiana Revised Statute Title 47, Section 103(D) provides that the secretary may grant a reasonable extension of time to file a state individual income tax return, not to exceed six months from the date the return is due.

1. To obtain a filing extension, the taxpayer must make the request on or before the tax return's due date.

2. A taxpayer must request a state filing extension by submitting an electronic application.

3. An electronic application may be submitted via:

- the Department of Revenue's web site at www.revenue.louisiana.gov/extensions;
- tax preparation software; or
- any other electronic method authorized by the secretary.

B. Filing Extension Does Not Extend Time to Pay Tax

1. A filing extension granted by the secretary only allows for an extension of time to file the tax return. The extension does not allow an extension of time to pay the tax due.

2. To avoid interest and penalty assessments, estimated taxes due must be paid on or before the original due date.

C. The secretary may waive the electronic filing of an extension if it is determined that complying with the requirement would cause an undue hardship.

AUTHORITY NOTE: Promulgated in accordance with R.S. 47:1511 and 287.614(D).

HISTORICAL NOTE: Promulgated by the Department of Revenue, Policy Services Division, LR 35:1137 (June 2009), amended LR 36:73 (January 2010), LR 39:

Family Impact Statement

The proposed amendment of LAC 61:III.2501, regarding individual income tax filing extensions, should not have any known or foreseeable impact on any family as defined by R.S. 49:972(D) or on family formation, stability and autonomy. Specifically, the implementation of this proposed Rule will have no known or foreseeable effect on:

1. the stability of the family;
2. the authority and rights of parents regarding the education and supervision of their children;
3. the functioning of the family;
4. family earnings and family budget;
5. the behavior and personal responsibility of children;
6. the ability of the family or a local government to perform this function.

Public Comments

Any interested person may submit written data, views, arguments, or comments regarding this proposed Rule to Nina Hunter, Attorney, Policy Services Division, Office of Legal Affairs by mail to P.O. Box 44098, Baton Rouge, LA 70804-4098. All comments must be received no later than 5:00 p.m., Wednesday, November 28, 2012.

Public Hearing

A public hearing will be held on Thursday, November 29, 2012, at 2:00 p.m. in the River Room, on the seventh floor of the LaSalle Building, 617 North Third Street, Baton Rouge, Louisiana.

Tim Barfield
Executive Counsel

FISCAL AND ECONOMIC IMPACT STATEMENT FOR ADMINISTRATIVE RULES RULE TITLE: Individual Income Tax Filing Extensions

I. ESTIMATED IMPLEMENTATION COSTS (SAVINGS) TO STATE OR LOCAL GOVERNMENT UNITS (Summary)

The proposed amendment to this Rule mandates the electronic filing of requests for extensions to file individual income tax returns for Tax Year 2012 and beyond. The electronic application already exists and there are no anticipated costs for implementation. The adoption of this amendment will allow the reallocation of resources being used to process paper extension requests to other tax processing functions.

Implementation of the proposed amendment to this Rule is expected to reduce the need for manual processing of paper extension requests which would allow the reallocation of resources to other areas necessary to fulfill the department's mission.

II. ESTIMATED EFFECT ON REVENUE COLLECTIONS OF STATE OR LOCAL GOVERNMENTAL UNITS (Summary)

An electronic filing mandate for extensions to file individual income tax returns will not alter the amount of tax due or collected, therefore it will have no effect on revenue collections of state or local governmental units. Extension requests are currently accepted by paper or electronically.

III. ESTIMATED COSTS AND/OR ECONOMIC BENEFITS TO DIRECTLY AFFECTED PERSONS OR NONGOVERNMENTAL GROUPS (Summary)

For the 2011 tax year, the last year in which state individual income tax returns were filed, approximately 121,000 extensions were filed, of which approximately 76,400 or 63 percent were filed on paper and 44,600 or 37 percent were filed

electronically. This proposed Rule limits the filing of extensions for individual state income tax returns to electronic means. Because many taxpayers already file extension requests electronically, and requests can be filed through the Louisiana Department of Revenue (LDR) web site for free, the cost to affected taxpayers is anticipated to be minimal. Also, taxpayers can obtain internet access to electronically file extensions at LDR offices and public libraries throughout the state. Taxpayers who file an extension through electronic means receive a notification of receipt which is an added benefit that paper filers did not receive. Those taxpayers unable to file electronically due to an undue hardship may have the electronic filing requirement waived by the secretary.

IV. ESTIMATED EFFECT ON COMPETITION AND EMPLOYMENT (Summary)

The proposed amendment to this Rule should not affect competition or employment.

Tim Barfield
Executive Counsel
1210#111

Gregory V. Albrecht
Chief Economist
Legislative Fiscal Office

NOTICE OF INTENT

Department of Transportation and Development Office of Highways/Engineering

Design-Build Pilot Program Repeal
(LAC 70:I.Chapter 7)

In accordance with the applicable provisions of the Administrative Procedure Act and R.S. 49:950 et seq., notice is hereby given that the Department of Transportation and Development intends to repeal Title 70, Part I, Chapter 7 of the Louisiana Administrative Code. Chapter 7 was adopted in accordance with R.S. 48:250.2(B) which required the Department of Transportation and Development to promulgate rules in accordance with the Administrative Procedure Act for the administration of a pilot program for design-build contracts.

Subsequently, the Louisiana Legislature repealed subsection B of R.S. 48:250.2 (Act 2004, No. 81, §2) which contained the department's rule making authority. The Louisiana Legislature additionally enacted R.S. 48:250.3 (Act 2004, No. 81, §1) to provide for the design build procedures and rules to be utilized by the department for the administration of the department design-build program. With the repeal of R.S. 48:250.2(B) and the enactment of R.S. 48:250.3, the department no longer has the authority or need to promulgate rules for the administration of its design-build program.

Title 70

TRANSPORTATION

Part I. Highway Construction

Chapter 7. DOTD Design-Build Contracting Pilot Program

§701. Purpose

Repealed.

AUTHORITY NOTE: Promulgated in accordance with R.S. 48:250.2.

HISTORICAL NOTE: Promulgated by the Department of Transportation and Development, Office of Highways/Engineering, LR 26:790 (April 2000), repealed LR 39:

§703. Qualification Requirements for Bidders

Repealed.

AUTHORITY NOTE: Promulgated in accordance with R.S. 48:250.2.

HISTORICAL NOTE: Promulgated by the Department of Transportation and Development, Office of Highways/Engineering, LR 26:791 (April 2000), repealed LR 39:

§705. Public Announcement Procedures

Repealed.

AUTHORITY NOTE: Promulgated in accordance with R.S. 48:250.2.

HISTORICAL NOTE: Promulgated by the Department of Transportation and Development, Office of Highways/Engineering, LR 26:791 (April 2000), repealed LR 39:

§707. Requirements of Letters of Interest by Competitors for the Design-Build Contract

Repealed.

AUTHORITY NOTE: Promulgated in accordance with R.S. 48:250.2.

HISTORICAL NOTE: Promulgated by the Department of Transportation and Development, Office of Highways/Engineering, LR 26:791 (April 2000), repealed LR 39:

§709. Criteria and Procedures for Choosing a Short List from Responding Firms

Repealed.

AUTHORITY NOTE: Promulgated in accordance with R.S. 48:250.2.

HISTORICAL NOTE: Promulgated by the Department of Transportation and Development, Office of Highways/Engineering, LR 26:791 (April 2000), repealed LR 39:

§710. Requirements for Bid Proposals by Competitors for Design-Build Contracts

Repealed.

AUTHORITY NOTE: Promulgated in accordance with R.S. 48:250.2.

HISTORICAL NOTE: Promulgated by the Department of Transportation and Development, Office of Highways/Engineering, LR 26:791 (April 2000), repealed LR 39:

§711. Composition and Appointment by the Secretary to the Technical Review Committee Grading and Judging the Technical Proposals for Ranking and Recommendation to the Chief Engineer

Repealed.

AUTHORITY NOTE: Promulgated in accordance with R.S. 48:250.2.

HISTORICAL NOTE: Promulgated by the Department of Transportation and Development, Office of Highways/Engineering, LR 26:792 (April 2000), repealed LR 39:

§713. Selection and Process of Award by the Chief Engineer and Execution of the Design-Build Contract by the Secretary for a Stipulated Sum

Repealed.

AUTHORITY NOTE: Promulgated in accordance with R.S. 48:250.2.

HISTORICAL NOTE: Promulgated by the Department of Transportation and Development, Office of Highways/Engineering, LR 26:792 (April 2000), repealed LR 39:

Family Impact Statement

1. What effect will this Rule have on the stability of the family? The repeal of the Rule will not affect the stability of the family.

2. What effect will this have on the authority and rights of persons regarding the education and supervision of their children? The repeal of the Rule will not affect the authority and rights of persons regarding the education and supervision of their children.

3. What effect will this have on the functioning of the family? The repeal of this Rule will not affect the functioning of the family.

4. What effect will this have on family earnings and family budget? The repeal of this Rule will not affect the family earnings or family budget.

5. What effect will this have on the behavior and personal responsibility of children? The repeal of this Rule will not affect the behavior or personal responsibility of children.

6. Is the family or local government able to perform the functions as contained in this proposed Rule? No, the repeal of this Rule does not affect the family or local governments and is strictly a state function.

Public Comments

All interested persons are invited to submit written comments on the proposed repeal of regulations. Persons commenting should reference this proposed regulation by LAC 70 Part 1, Chapter 7 (Design-Build Rule Repeal). Comments must be received no later than 30 days from the date of publication of this notice, addressed to Cheryl Duvieilh, Executive Counsel, Department of Transportation and Development, Post Office Box 94245, Baton Rouge, LA 70804-9245.

Sherri LeBas, P.E.
Secretary

FISCAL AND ECONOMIC IMPACT STATEMENT FOR ADMINISTRATIVE RULES

RULE TITLE: Design-Build Pilot Program Repeal

I. ESTIMATED IMPLEMENTATION COSTS (SAVINGS) TO STATE OR LOCAL GOVERNMENTAL UNITS (Summary)

There will be no costs to state or local governmental units associated with the repeal of this rule. The proposed change seeks to repeal Title 70, Part I, Chapter 7 of the Louisiana Administrative Code. This chapter provided rules for the administration of a pilot program for design-build contracts. Subsequent legislation in the 2004 Regular Session of the Louisiana Legislature (Act 2004, No. 81) repealed the department's rule making authority with regard to design-build contracts and provided for design-build procedures and for the administration of the design-build program.

II. ESTIMATED EFFECT ON REVENUE COLLECTIONS OF STATE OR LOCAL GOVERNMENTAL UNITS (Summary)

There will be no effect on revenue collections of state or local governmental units associated with the repeal of this rule.

III. ESTIMATED COSTS AND/OR ECONOMIC BENEFITS TO DIRECTLY AFFECTED PERSONS OR NONGOVERNMENTAL GROUPS (Summary)

There are no estimated costs or economic benefits to directly affected persons or non-governmental groups associated with the repeal of this rule.

IV. ESTIMATED EFFECT ON COMPETITION AND EMPLOYMENT (Summary)

There is no estimated effect on competition and employment associated with the repeal of this rule.

Sherri LeBas, P.E.
Secretary
1210#035

Evan Brasseaux
Staff Director
Legislative Fiscal Office

NOTICE OF INTENT

Department of Transportation and Development Office of Multimodal Planning

Port Design-Build Pilot Program
(LAC 56:III.Chapter 23)

Notice is hereby given in accordance with the provisions of the Administrative Procedure Act, R.S. 49:950 et seq., and through the authority granted in R.S. 34:3523(I) and R.S. 34:3460, that the Department of Transportation and Development, Office of Multimodal Planning proposes to adopt Chapter 23 to facilitate the implementation of the port design-build pilot program.

Title 56

PUBLIC WORKS

Part III. Flood Control and Water Management

Subpart 2. Port Construction and Development Priority Program

Chapter 23. Port Design-Build Pilot Program

§2301. Purpose

A. A port design-build pilot program was authorized by Act 755 of the 2012 Regular Session of the Louisiana State Legislature. The purpose of this Rule is to establish procedures and guidelines for the implementation of the pilot program.

AUTHORITY NOTE: Promulgated in accordance with R.S. 38:3523.

HISTORICAL NOTE: Promulgated by the Department of Transportation and Development, Office of Multimodal Planning, LR 39:

§2303. Applicability

A. Any port may use the design build method, pursuant to the pilot program as specified and limited by R.S. 34:2523, on any non-architectural project where the project involves the transport, production, storage, or manufacturing of port cargos and where 60 percent or more of the construction cost estimate in the design criteria package, as determined by the port's retained design professional, consists of engineered products and components and services, fabrication, and installation for such products and components.

B. A port may utilize the design-build method on projects funded by any manner for any port project in which a notice of intent is advertised in accordance with R.S. 34:3523 prior to December 31, 2015.

AUTHORITY NOTE: Promulgated in accordance with R.S. 38:3523.

HISTORICAL NOTE: Promulgated by the Department of Transportation and Development, Office of Multimodal Planning, LR 39:

§2305. Approval Process

A. The proposed design-build projects shall be processed for approval on a first-come first-served basis.

B. A port seeking to participate in the design-build pilot program shall retain a design professional for each proposed project. The design professional shall prepare a design criteria package for each proposed project. The design professional and the design criteria package shall meet all requirements set forth in R.S. 34:3523

C. If the port is seeking approval for the project pursuant to the Port Priority Program, the port shall comply with all applicable rules relative to Port Priority Program projects.

D. If the port is not seeking participation in the Port Priority Program, the following rules shall apply.

1. A completed design criteria package must be submitted to the department prior to submission to the joint legislative committee for approval, along with a resolution from the governing authority for the port verifying its commitment to complete the design-build project and which contains a statement that the port has the funding necessary to do so.

2. The department is responsible for ensuring the design package contains all of the elements required by R.S. 34:3523. The department will not recommend approval for the design-build project, nor will the department be responsible for making findings relative to the accuracy of the information provided in the design criteria package.

3. If the department determines that the design criteria package is complete and the resolution from the governing authority for port is sufficient, it shall issue a letter to the port stating same. The letter shall serve as authorization for the port to submit the design criteria package and the resolution to the joint legislative committee for approval. The design criteria package and resolution shall be submitted to the joint legislative committee within 30 days of publishing the notice of intent as required by R.S. 34:3523(c).

4. The port shall notify the department of the outcome of the joint legislative committee.

a. If the project is approved or if the joint legislative committee fails to act within 60 days from receipt of the proposed project, the port so shall notify the department and may proceed with implementation of the project.

b. All aspects of the project must comply with all applicable laws, rules and regulations relative to the design-build pilot program including, but not limited to, R.S. 34:3523.

D. Unless the design-build project is also a Port Priority Program project, the department shall not participate in or monitor the project beyond the application and approval processes.

E. Procedures for Withdrawal of Projects

1. If after receiving approval for the proposed project, the port elects not to proceed with the construction of the project, the governing authority for the port shall provide the joint legislative committee and the department with written notice that it is withdrawing its project from the pilot program.

2. Once the project is withdrawn by the port, the project is no longer eligible for the design-build pilot program without resubmitting the design criteria package to the department and the joint legislative committee for approval. Any such resubmitted project shall be placed in line behind all other pending project approvals received by the department.

AUTHORITY NOTE: Promulgated in accordance with R.S. 38:3523.

HISTORICAL NOTE: Promulgated by the Department of Transportation and Development, Office of Multimodal Planning, LR 39:

§2307. Project Limits

A. Once the department receives notice that ten projects have been approved by the joint legislative committee, the department will cease processing any further projects. If however a project has been withdrawn from the pilot

program, the department will process applications in the order of their submission.

AUTHORITY NOTE: Promulgated in accordance with R.S. 38:3523.

HISTORICAL NOTE: Promulgated by the Department of Transportation and Development, Office of Multimodal Planning, LR 39:

Family Impact Statement

1. What effect will this Rule have on the stability of the family? This Rule will not affect the stability of the family.

2. What effect will this have on the authority and rights of persons regarding the education and supervision of their children? This Rule will not affect the authority and rights of persons regarding the education and supervision of their children.

3. What effect will this have on the functioning of the family? This Rule will not affect the functioning of the family.

4. What effect will this have on family earnings and family budget? This Rule will not affect the family earnings or family budget.

5. What effect will this have on the behavior and personal responsibility of children? This Rule will not affect the behavior or personal responsibility of children.

6. Is the family or local government able to perform the functions as contained in this proposed Rule? No, this Rule does not affect the family or local governments and is strictly a state function.

Public Comments

All interested persons are invited to submit written comments on the proposed Port Design-Build Pilot Program Rule. Persons commenting should reference this proposed regulation by "Port Design-Build Pilot Program." Comments must be received no later than 30 days from the date of publication of this notice, addressed to Phillip Jones, Deputy Assistant Secretary, Department of Transportation and Development, P.O. Box 94245, Baton Rouge, LA 70804-9245.

Sherri H. LeBas, P.E.
Secretary

FISCAL AND ECONOMIC IMPACT STATEMENT FOR ADMINISTRATIVE RULES RULE TITLE: Port Design-Build Pilot Program

I. ESTIMATED IMPLEMENTATION COSTS (SAVINGS) TO STATE OR LOCAL GOVERNMENT UNITS (Summary)

There is no anticipated direct material effect on governmental expenditures as a result of this proposed administrative rule. The proposed administrative rule merely provides for the approval processes required for ports wanting to participate in the port design-build pilot program authorized by Act 756 of the 2012 Regular Session of the Louisiana Legislature. Act 756 authorizes ports to utilize the design-build project delivery system for contracting non-architectural capital outlay projects while limiting the pilot program to 10 projects statewide through December 31, 2015.

II. ESTIMATED EFFECT ON REVENUE COLLECTIONS OF STATE OR LOCAL GOVERNMENTAL UNITS (Summary)

There is no direct material effect on governmental revenues as a result of this proposed administrative rule.

III. ESTIMATED COSTS AND/OR ECONOMIC BENEFITS TO DIRECTLY AFFECTED PERSONS OR NONGOVERNMENTAL GROUPS (Summary)

There are no material costs or economic benefits directly affecting persons or non-governmental groups as a result of this proposed rule. However, design-build projects are generally constructed in a more efficient manner potentially reducing project duration and expediting the initiation of additional economic activity within ports utilizing design-build in the state.

IV. ESTIMATED EFFECT ON COMPETITION AND EMPLOYMENT (Summary)

All businesses impacted by the proposed administrative rule will be impacted equally. To the degree that project duration is shortened due to the design-build process, ports may be capable of expanding capacity and employment more quickly than would be possible under a traditional design-bid-build project.

Sherri H. LeBas, P.E.
Secretary
1210#015

Evan Brasseaux
Staff Director
Legislative Fiscal Office

NOTICE OF INTENT

Department of Transportation and Development Office of Operations and Department of Public Safety and Corrections Office of State Police

Special Permit for Vehicles Hauling Sugarcane
(LAC 73:I.303)

In accordance with the applicable provisions Administrative Procedure Act, R.S. 49:950 et seq., notice is hereby given that the Louisiana Department of Transportation and Development, Office of Operations, in cooperation with the Department of Public Safety and Corrections, Office of State Police, and by the authority granted in R.S. 32:387.7(A) intends to amend Title 73, Part I, Chapter 3 to clarify the requirements relative to an additional sixth axle required on vehicles hauling sugarcane up to 100,000 pounds.

Title 73

WEIGHTS, MEASURES AND STANDARDS

Part I. Weights and Standards

Chapter 3. Oversize and Overweight Permit §303. Types of Permits

A. - J. ...

K. Vehicles Hauling Sugarcane. These permits are issued annually for vehicles hauling sugarcane at a gross weight not to exceed 100,000 pounds. The vehicle and trailer combination must meet all other Louisiana legal requirements and shall have an additional single axle on the sugarcane trailer for a total of six axles for the vehicle and trailer combination. The additional axle must be equipped with dual mounted tires lowered to the ground and functioning as a load bearing axle when hauling sugarcane. The fee for these permits is \$100 per permit per year. (The legal requirements can be found in a manual entitled *Louisiana Regulations for Trucks, Vehicles and Loads 2012* available on the internet at <https://perba.dotd.louisiana.gov/welcome.nsf/RegBook2012>)

AUTHORITY NOTE: Promulgated in accordance with R.S. 32:2 et seq.

HISTORICAL NOTE: Promulgated by the Department of Transportation and Development, Office of Highways, LR 5:36 (February 1979), amended by the Department of Transportation and Development, Office of Operations and the Department of Public Safety and Corrections, Office of State Police, LR 39:

Family Impact Statement

The proposed amendment to this Rule should not have any known or foreseeable impact on any family as defined by R.S. 49:972(D) or on family formation, stability and autonomy. Specifically:

1. the implementation of this proposed amendment will have no known or foreseeable effect on the stability of the family;

2. the implementation of this proposed amendment will have no known or foreseeable effect on the authority and rights of parents regarding the education and supervision of their children;

3. the implementation of this proposed amendment will have no known or foreseeable effect on the functioning of the family;

4. the implementation of this proposed amendment will have no known or foreseeable effect on the family earnings and family budget;

5. the implementation of this proposed amendment will have no known or foreseeable effect on the behavior and personal responsibility of children;

6. the implementation of this proposed amendment will have no known or foreseeable effect on the ability of the family or local government to perform this function.

Public Comments

All interested persons so desiring shall submit oral or written data, views, comments or arguments no later than 30 days from the date of publication of this Notice of Intent to Brandon Brown, General Counsel, Legal Section, Department of Transportation and Development, P.O. Box 94245, Baton Rouge, LA 70804-9245, telephone (225) 242-4656.

Sherri H. LeBas, P.E.
Secretary

FISCAL AND ECONOMIC IMPACT STATEMENT FOR ADMINISTRATIVE RULES

RULE TITLE: Special Permit for Vehicles Hauling Sugarcane

I. ESTIMATED IMPLEMENTATION COSTS (SAVINGS) TO STATE OR LOCAL GOVERNMENT UNITS (Summary)

There will be no costs or savings to state or local governmental units as a result of the proposed rule change. Act 462 of the 2012 Regular Legislative Session prohibits the secretary of the Department of Transportation and Development from issuing permits for vehicles hauling sugarcane with a vehicle combination at a gross weight of one hundred thousand pounds unless said vehicle is outfitted with a minimum of six axles for the vehicle and trailer combination. The legislation was silent with regard to whether the sixth axle should be equipped with single or dual mounted tires. The proposed rule specifies that the extra axle shall be equipped with dual mounted tires.

II. ESTIMATED EFFECT ON REVENUE COLLECTIONS OF STATE OR LOCAL GOVERNMENTAL UNITS (Summary)

There will be no effect on revenue collections of state or local governmental units as a result of the proposed rule change.

III. ESTIMATED COSTS AND/OR ECONOMIC BENEFITS TO DIRECTLY AFFECTED PERSONS OR NONGOVERNMENTAL GROUPS (Summary)

The adoption of the proposed rule change will result in increased costs of approximately \$500 per vehicle used to haul sugarcane and will provide economic benefits to owners through reduced transportation costs. Effective August 1, 2012, Act 462 of the 2012 Regular Session of the Louisiana State Legislature amended R.S. 32:387.7(B) to prohibit the secretary of the Department of Transportation and Development from issuing permits for vehicles hauling sugarcane with a vehicle combination at a gross weight of one hundred thousand pounds without an additional single axle on the sugarcane trailer for a total of six axles for the vehicle and trailer combination.

Act 462 did not specify whether the additional sixth axle had to be equipped with single or dual mounted tires. The department, in cooperation with the Department of Public Safety and Corrections, Office of State Police, has determined that dual mounted tires on the additional axle are necessary for the safe operation of the vehicles on interstate, state and local roadways. Dual mounting distributes the weight of the load in a manner calculated to prevent excessive damage to roadways and bridges.

The additional two tires necessary for dual mounting will cost sugarcane vehicle owners approximately \$500. The economic benefit to the sugarcane industry is that they will be able to haul larger quantities of sugarcane in a single vehicle, which should result in reduced transportation costs.

IV. ESTIMATED EFFECT ON COMPETITION AND EMPLOYMENT (Summary)

There will be no anticipated effect on competition and employment as a result of the adoption of this proposed rule.

Sherri H. LeBas, P.E.
Secretary
1210#034

Evan Brasseaux
Staff Director
Legislative Fiscal Office

NOTICE OF INTENT

Department of Treasury Board of Trustees of the Louisiana State Employees' Retirement System

Election to the Board of Trustees
(LAC 58:I.401, 405, and 407)

The Department of the Treasury, Board of Trustees of the Louisiana State Employees' Retirement System ("LASERS") proposes to amend LAC 58:I.401, 405, and 407. These Rule amendments change LAC 58:I.401 regarding certain dates in the election process as well as clarifies certain language in the Rule. The proposed amendments also change LAC 58:I.405 regarding the definition of retired member in reference to the election process as well as clarifying certain language pertaining to the schedule of tallying votes. Further, these Rule amendments add language to LAC 58:I.407 regarding winning candidates in LASERS' Board of Trustees elections for active and retired members in situations where candidates run unopposed. No preamble for

these Rule changes has been prepared. These Rule changes comply with and are enabled by R.S. 11:515.

Title 58

RETIREMENT

Part I. Louisiana State Employees' Retirement System Chapter 4. Rules Common to the Election of Both Active and Retired Member Trustees

§401. General Schedule of Elections [Formerly §§301 and 501.B]

A. - A.2. ...

B. The schedule for elections shall be as follows:

1. first day in March: nominations shall be opened;
2. second Tuesday in July: nominations shall be closed. All nominating petitions must be received by the close of business (4:30 p.m. Central time);
3. Monday following second Tuesday in July: a drawing shall be held to determine candidate positions on a ballot;
4. fourth Friday in September: the final day that information on candidates and ballots may be mailed;
5. fourth Friday in October: all ballots or electronic votes must be received by the close of business (4:30 p.m. Central time). No faxed ballots shall be accepted;
6. Wednesday following fourth Friday in October: all ballots and electronic votes shall be tallied and verified by this date;
7. regular November meeting: the board shall be presented with the certified ballot count, and if it is accepted, shall authorize publication of results;
8. January following election: newly elected members receive orientation; oaths shall be taken prior to the regular January meeting.

C. ...

AUTHORITY NOTE: Promulgated in accordance with R.S. 11:511 and R.S. 11:515.

HISTORICAL NOTE: Promulgated by the Department of Treasury, Board of Trustees of the State Employees' Retirement System, LR 22:373 (May 1996), amended LR 23:996, 997 (August 1997), LR 25:1278 (July 1999), LR 26:2633 (November 2000), LR 33:1151 (June 2007), LR 34:446, 447 (March 2008), LR 37:1615 (June 2011), LR 39:

§405. Election Process [Formerly §§303.C-I and 503.C-J]

A. ...

B. Retired Members—ballots or election brochures shall be distributed to each retired member by the fourth Friday in September. A member who is deemed by LASERS to be retired before July 1 of the year in which the election is to take place shall be considered a retired member for the purposes of this section.

C. - F. ...

G. Votes shall be tallied in accordance with the general schedule of elections.

H. - I. ...

AUTHORITY NOTE: Promulgated in accordance with R.S. 11:511 and R.S. 11:515.

HISTORICAL NOTE: Promulgated by the Department of Treasury, Board of Trustees of the State Employees' Retirement System, LR 22:373 (May 1996), amended LR 23:996, 997 (August 1997), LR 25:1278 (July 1999), LR 26:1490 (July 2000), LR 26:2633 (November 2000), LR 31:946, 947 (April 2005), LR 34:446, 447 (March 2008), LR 37:1616 (June 2011), LR 39:

§407. Winning Candidates

[Formerly §§303.B & G; 501.A and 503.H]

A. - C. ...

D. If, after the conclusion of the nomination process, the number of candidates does not exceed or is fewer than the number of open positions for which election is being held, no election shall be held for those positions, and those candidates that are nominated and are qualified shall be deemed successful candidates and presented to the board.

1. Active Member Trustees' Elections—any remaining open positions shall be filled in accordance with Title 58, Part I, Chapter 3, §305 of the *Louisiana Administrative Code*.

2. Retired Member Trustees' Elections—any remaining open positions shall be filled in accordance with Title 58, Part I, Chapter 5, §505 of the *Louisiana Administrative Code*.

E. Subsection D shall apply to both Active Member Trustee Elections and Retired Member Trustee Elections.

F. For all relevant purposes, those candidates elected under Subsection D shall be considered to have received the maximum number of votes possible.

AUTHORITY NOTE: Promulgated in accordance with R.S. 11:511 and R.S. 11:515.

HISTORICAL NOTE: Promulgated by the Department of Treasury, Board of Trustees of the State Employees' Retirement System, LR 22:373 (May 1996), amended LR 23:996, 997 (August 1997), LR 25:1278 (July 1999), LR 26:1490 (July 2000), LR 26:2633 (November 2000), LR 31:946, 947 (April 2005), LR 34:446, 447 (March 2008), LR 37:1616 (June 2011), LR 39:

Family Impact Statement

The proposed Rule amends LAC 58:I.401, 405 and 407. These Rule changes should not have any known or foreseeable impact on any child, individual or family as defined by R.S. 49:972.D or on family formation, stability and autonomy. Specifically, there should be no known or foreseeable effect on:

1. the stability of the family;
2. the authority and rights of parents regarding the education and supervision of their children;
3. the functioning of the family;
4. family earnings and family budget
5. the behavior and personal responsibility of children;
6. the ability of the family or a local government to perform the function as contained in the proposed Rules.

Small Business Statement

The impact of the proposed Rule on small businesses as defined in the Regulatory Flexibility Act has been considered. It is estimated that the proposed action is not expected to have a significant adverse impact on small businesses. The agency, consistent with health, safety, environmental and economic welfare factors has considered and, where possible, utilized regulatory methods in the drafting of the proposed Rule that will accomplish the objectives of applicable statutes while minimizing the adverse impact of the proposed Rule on small businesses.

Poverty Impact Statement

The proposed Rule amends LAC 58:I.401, 405 and 407. These Rule changes should not have any known or foreseeable impact on any child, individual or family as

defined by R.S. 49:973.D. Specifically, there should be no known or foreseeable effect on:

1. the effect on household income, assets, and financial security;
2. the effect on early childhood development and preschool through postsecondary education development;
3. the effect on employment and workforce development;
4. the effect on taxes and tax credits;
5. the effect on child and dependent care, housing, health care, nutrition, transportation, and utilities assistance.

Public Comments

Interested persons may submit written comments on the proposed changes until 4:30 pm, November 23, 2012, to Steve Stark, Deputy General Counsel, Board of Trustees for the Louisiana State Employees' Retirement System, P.O. Box 44213, Baton Rouge, LA 70804.

Maris E. LeBlanc
Deputy Director

FISCAL AND ECONOMIC IMPACT STATEMENT FOR ADMINISTRATIVE RULES

RULE TITLE: Election to the Board of Trustees

I. ESTIMATED IMPLEMENTATION COSTS (SAVINGS) TO STATE OR LOCAL GOVERNMENT UNITS (Summary)

The proposed Rule changes will have no impact on state or local government expenditures other than the nominal cost of publishing the Rules in the *Louisiana Register*. The amendments include: 1.) Moving back the drawing for each candidate's position on the ballot one business day to allow time for receipt of original nominating petitions pursuant to LAC 58:I.403; 2.) Simplification of the election schedule by referring to the general schedule of elections for the deadline for tallying of votes; 3.) Clarification of the date all ballots and electronic votes shall be tallied and verified; 4.) Rather than distributing member ballots to each member appearing on the June Retiree Master List, which doesn't exist, the Rule will specify that those deemed by LASERS as retired before July 1st of the year of the election are to receive retired member ballots. Finally, the changes add provisions to provide for situations in which candidates run unopposed.

II. ESTIMATED EFFECT ON REVENUE COLLECTIONS OF STATE OR LOCAL GOVERNMENTAL UNITS (Summary)

There shall be no effect on revenue collections of state or local governmental units as a result of the implementation of this Rule change.

III. ESTIMATED COSTS AND/OR ECONOMIC BENEFITS TO DIRECTLY AFFECTED PERSONS OR NONGOVERNMENTAL GROUPS (Summary)

Candidates for election to the LASERS board of trustees would be directly affected by the proposed action; however, none of the Rule changes are anticipated to result in associated costs or economic benefits.

IV. ESTIMATED EFFECT ON COMPETITION AND EMPLOYMENT (Summary)

No effect on competition or employment in the public or private sectors is anticipated to result from the proposed Rule change.

Cindy Rougeou
Executive Director
1210#023

Evan Brasseaux
Staff Director
Legislative Fiscal Office

NOTICE OF INTENT

Department of Treasury Board of Trustees of the Louisiana State Employees' Retirement System

Plan Year; Limitations Year (LAC 58:I.115, 117)

The Department of the Treasury, Board of Trustees of the Louisiana State Employees' Retirement System ("LASERS") proposes the addition of LAC 58:I.115 and 117 which establish a plan year and a limitations year for LASERS. These additions codify the current practices of LASERS with regards to plan year and limitations year which follow IRS guidelines. No preamble for these Rule adoptions has been prepared. These Rule adoptions comply with and are enabled by R.S. 11:515.

Title 58

RETIREMENT

Part I. Louisiana State Employees' Retirement System Chapter 1. General Provisions

§115. Plan Year

A. The Plan Year for LASERS shall be July 1 through June 30.

AUTHORITY NOTE: Promulgated in accordance with R.S. 11:515.

HISTORICAL NOTE: Promulgated by the Department of Treasury, Board of Trustees of the State Employees' Retirement System, LR 39:

§117. Limitations Year

A. The Limitations Year for LASERS shall be January 1 through December 31.

AUTHORITY NOTE: Promulgated in accordance with R.S. 11:515.

HISTORICAL NOTE: Promulgated by the Department of Treasury, Board of Trustees of the State Employees' Retirement System, LR 39:

Family Impact Statement

The proposed Rule adds LAC 58:I.115 and 117. These Rule changes should not have any known or foreseeable impact on any child, individual or family as defined by R.S. 49:972.D or on family formation, stability and autonomy. Specifically, there should be no known or foreseeable effect on:

1. the stability of the family;
2. the authority and rights of parents regarding the education and supervision of their children;
3. the functioning of the family;
4. family earnings and family budget
5. the behavior and personal responsibility of children;
6. the ability of the family or a local government to perform the function as contained in the proposed Rules.

Small Business Statement

The impact of the proposed Rule on small businesses as defined in the Regulatory Flexibility Act has been considered. It is estimated that the proposed action is not expected to have a significant adverse impact on small businesses. The agency, consistent with health, safety, environmental and economic welfare factors has considered and, where possible, utilized regulatory methods in the

drafting of the proposed Rule that will accomplish the objectives of applicable statutes while minimizing the adverse impact of the proposed Rule on small businesses.

Poverty Impact Statement

The proposed Rule amends LAC 58:I.115 and 117. These Rule changes should not have any known or foreseeable impact on any child, individual or family as defined by R.S. 49:973.D. Specifically, there should be no known or foreseeable effect on:

1. the effect on household income, assets, and financial security;
2. the effect on early childhood development and preschool through postsecondary education development;
3. the effect on employment and workforce development;
4. the effect on taxes and tax credits;
5. the effect on child and dependent care, housing, health care, nutrition, transportation, and utilities assistance.

Public Comments

Interested persons may submit written comments on the proposed changes until 4:30 pm, November 23, 2012, to Steve Stark, Deputy General Counsel, Board of Trustees for the Louisiana State Employees' Retirement System, P.O. Box 44213, Baton Rouge, LA 70804.

Cindy Rougeou
Executive Director

FISCAL AND ECONOMIC IMPACT STATEMENT FOR ADMINISTRATIVE RULES RULE TITLE: Plan Year; Limitations Year

- I. ESTIMATED IMPLEMENTATION COSTS (SAVINGS) TO STATE OR LOCAL GOVERNMENT UNITS (Summary)
The proposed Rule changes will have no impact on state or local government expenditures other than the nominal cost of publishing the Rules in the *Louisiana Register*. The Rule additions simply codify (put into written regulations) current, federally mandated, practice regarding the LASERS' plan year and limitations year.
- II. ESTIMATED EFFECT ON REVENUE COLLECTIONS OF STATE OR LOCAL GOVERNMENTAL UNITS (Summary)
There shall be no effect on revenue collections of state or local governmental units as a result of the implementation of this Rule change.
- III. ESTIMATED COSTS AND/OR ECONOMIC BENEFITS TO DIRECTLY AFFECTED PERSONS OR NONGOVERNMENTAL GROUPS (Summary)
There shall be no cost or benefit to any affected persons or non-governmental groups.
- IV. ESTIMATED EFFECT ON COMPETITION AND EMPLOYMENT (Summary)
No effect on competition or employment in the public or private sectors is anticipated to result from the proposed Rule change.

Cindy Rougeou
Executive Director
1210#022

Evan Brasseaux
Staff Director
Legislative Fiscal Office

NOTICE OF INTENT

Department of Wildlife and Fisheries Wildlife and Fisheries Commission

Falconry (LAC 76:V.301)

The Department of Wildlife and Fisheries and the Wildlife and Fisheries Commission do hereby advertise their intent to promulgate rules for use of snares and amend the rules relative to falconry.

Title 76

WILDLIFE AND FISHERIES

Part V. Wild Quadrupeds and Wild Birds

Chapter 3. Wild Birds

§301. Falconry

A. The Louisiana falconry regulations pertain to the use of native raptors (Accipitriformes—vultures, osprey, kites, harriers, accipiters, buteos, and eagles; Falconiformes—caracaras and falcons; and Strigiformes—owls) that are protected under the Migratory Bird Treaty Act, and exotic raptors, for purposes of falconry. No person may possess wild or captive bred raptors for the purpose of falconry without a valid permit as provided in these regulations.

B. Definitions

Aerie—the nest of an eagle or other bird of prey, built in a high inaccessible place such as a cliff face.

Department—Louisiana Department of Wildlife and Fisheries.

Eyass—a young raptor that is still in the nest.

Falconer—a person with a valid Louisiana game breeder's license for falconry or a person with a valid falconry license/permit from another state.

Hack—temporary release of a falconry raptor to the wild for purposes of conditioning and training.

Hybrid—offspring produced from the cross-breeding of two or more species of raptors or offspring of cross-bred raptors.

Imping—using a feather to repair or replace a broken feather of a raptor.

Imprinted Raptor—a raptor that was hand-raised from two weeks of age, or younger, until it has fledged; it is considered an imprint for the duration of its life.

Molting Weight—the heavier, non-hunting weight of a raptor, when the weight is not reduced for training and hunting.

Passage Bird—a raptor that has left the nest and is less than one year of age.

Permit—Louisiana game breeder's license for falconry.

Sponsor—a general or master falconer with a valid Louisiana falconry license who is at least 18 years old and has at least 2 years of experience at the general falconer level who agrees to supervise the training of an apprentice falconer.

Take—to trap or capture a wild raptor, including removal of a nestling from a nest or aerie.

Wild Raptor—a species of native raptor that originated in the wild. No matter how long the bird is held in captivity, or whether it was transferred to another licensee, it remains a wild bird. However, for purposes of wild take restrictions, the department does not consider the raptor to be taken from the wild by any subsequent licensee to whom it is legally transferred.

USFWS—U.S. Fish and Wildlife Service.

C. Types of Permits, Requirements and Responsibilities

1. Apprentice Permit

a. Apprentice falconers must be at least 16 years of age.

b. An apprentice falconer under 18 years of age must have a parent or legal guardian sign the application, attesting that he or she is legally responsible for the permittee's activities.

c. An apprentice falconry applicant must have a letter from a sponsor, stating that he or she will assist the apprentice with learning about the husbandry and training of raptors held for falconry, relevant laws and regulations and deciding what species of raptor is appropriate for the apprentice.

d. Apprentice falconry applicants must correctly answer at least 80 percent of the questions on the falconry exam to qualify for a license. The applicant's facilities and equipment must pass an inspection before obtaining a bird.

e. Apprentice falconers may possess no more than one raptor for use in falconry, even if the permittee has a falconry permit issued in another state.

f. Apprentice falconers may take a wild raptor of any species except, a bald eagle (*Haliaeetus leucocephalus*), a white-tailed eagle (*Haliaeetus albicilla*), a Steller's sea-eagle (*Haliaeetus pelagicus*), a golden eagle (*Aquila chrysaetos*), a swallow-tailed kite (*Elanoides forficatus*), a Swainson's hawk (*Buteo swainsoni*), a peregrine falcon (*Falco peregrinus*), a flammulated owl (*Otus flammeolus*), an elf owl (*Micrathene whitneyi*), a short-eared owl (*Asio flammeus*) or any federally listed endangered or threatened species.

g. Apprentice falconers may possess any Accipitriform, Falconiform, or Strigiform raptor species, including wild, captive-bred, or hybrid individuals, except a federally listed threatened or endangered species or a bald eagle, a white-tailed eagle, a Steller's sea-eagle, a golden eagle, or a swallow-tailed kite.

h. Apprentice falconers do not need to capture their own wild raptor; a raptor can be transferred to an apprentice falconer by another falconer.

i. Apprentice falconers may only take raptors less than one year old, except nestlings may not be taken.

j. Apprentice falconers may not possess a raptor taken from the wild as a nestling.

k. Apprentice falconers may not possess a raptor that is imprinted on humans.

l. Apprentice falconers may take passage birds from September 1-February 28 only.

2. General Permit

a. General falconers must be at least 16 years of age.

b. A general permit applicant under 18 years of age must have a parent or legal guardian sign the application, attesting that he or she is legally responsible for the permittee's activities.

c. General permit applicants must submit a document from a general falconer or master falconer (preferably the applicant's sponsor) stating that the applicant has practiced falconry at the apprentice level or equivalent for at least two years, including maintaining, training, flying, and hunting the raptor(s) for at least four months in each year. That practice may include capture and release of falconry raptors.

d. General permit falconry applicants may not substitute any falconry school or education program to shorten the period of 2 years at the apprentice level.

e. General falconers may take and possess any Accipitriform, Falconiform, or Strigiform raptor except a bald eagle, a white-tailed eagle, a Steller's sea-eagle, a golden eagle, a swallow-tailed kite. Except peregrine falcons may only be taken by general falconers in possession of a valid peregrine falcon trapping permit.

NOTE: The number of peregrine falcon trapping permits is very limited. Additional regulations apply to the take and possession of federally listed threatened and endangered species.

f. General falconers may use captive-bred individuals and hybrids of the species authorized for possession.

g. General falconers may possess no more than three raptors, even if the licensee has falconry permit issued in another state.

h. General falconers may remove nestlings from a nest or aerie, provided at least one nestling is left inside the nest or aerie.

i. General falconers may take passage birds, except peregrine falcons, from September 1-February 28 only and eyasses year-round. General falconers may take an American kestrel (*Falco sparverius*) or a great horned owl (*Bubo virginianus*) of any age from the wild from September 1-February 28 only. Peregrine falcons (passage birds only) may be taken by general falconers in possession of a valid peregrine falcon trapping permit from September 20-October 20 only.

3. Master Permit

a. Master permit applicants must have practiced falconry with his or her raptor(s) at the general falconer level for at least five years.

b. Master falconers may take and possess any Accipitriform, Falconiform, or Strigiform raptor except a bald eagle or a swallow-tailed kite. Except peregrine falcons may only be taken by master falconers in possession of a valid peregrine falcon trapping permit.

NOTE: The number of peregrine falcon trapping permits is very limited. Additional regulations apply to take and possession of federally listed endangered and threatened species.

c. Master falconers may take and possess a golden eagle, a white-tailed eagle, or a Steller's sea-eagle after obtaining authorization for eagles and sea-eagles from the department.

d. Master falconers may possess captive-bred individuals or hybrids of species authorized for possession.

e. Master falconers may possess no more than five wild raptors even if the licensee has a falconry permit issued in another state.

f. Master falconers may possess any number of captive-bred raptors, but must train them in the pursuit of wild game and use them in hunting.

g. Master falconers may remove nestlings from a nest or aerie provided at least one nestling is left inside the nest or aerie.

h. Master falconers may take passage birds, except peregrine falcons, from September 1-February 28 only and eyasses year-round. Master falconers may take an American kestrel or a great horned owl of any age from the wild from September 1-February 28 only. Peregrine falcons (passage birds only) may be taken by master falconers in possession of a valid peregrine falcon trapping permit from September 20-October 20 only.

4. Nonresident Permit

a. A non-resident falconer who resides in Louisiana for more than 120 consecutive days but who does not intend to establish residency must obtain a nonresident falconry license.

b. Non-resident falconers shall possess a valid falconry permit or license from his or her state of residence. A copy of this permit or license shall be submitted with the non-resident falconry permit application.

c. Non-resident falconers may not import or possess more raptors than allowed by their state of residence.

d. Non-resident falconers may not take more than two raptors in Louisiana during the calendar year.

e. Raptors taken from the wild in Louisiana must be species the non-resident falconer is authorized to possess in their state of residence, except peregrine falcons may not be taken in Louisiana by non-resident falconers.

f. While in Louisiana, non-resident falconers must keep their raptors in facilities that have passed the Louisiana falconry facility inspection.

g. Non-resident falconers may take passage birds, except peregrine falcons, from September 1-February 28 only.

h. Non-resident falconers at the general or master level may take eyasses year-round, provided at least one nestling is left in the nest or aerie.

5. Raptor Propagator Permit. A Louisiana game breeder's license for falconry and a USFWS raptor propagation permit must be obtained to legally propagate raptors in Louisiana. Properly permitted propagators:

a. shall comply with federal raptor propagation regulations and reporting requirements;

b. shall obtain written authorization from the department before taking wild raptors or eggs;

c. shall submit a Louisiana raptor harvest report form (available on the department website) to the department within 10 days of taking a raptor or raptor egg in Louisiana;

d. may take and possess any Accipitriform, Falconiform or Strigiform raptor except a bald eagle, a golden eagle, or a swallow-tailed kite. Except peregrine falcons may only be taken by general or master falconers in possession of a valid peregrine falcon trapping permit;

NOTE: The number of peregrine falcon trapping permits is very limited. Additional regulations apply to take and

possession of federally listed endangered and threatened species.

e. may possess captive-bred individuals or hybrids of species authorized for possession;

f. may possess any number of wild or captive-bred raptors;

g. may remove eggs or nestlings from a nest or aerie provided at least one egg or nestling is left;

h. may take passage birds, except peregrine falcons, from September 1-February 28 and eggs and eyasses year-round. May take an American kestrel or a great horned owl of any age from the wild from September 1-February 28 only. Peregrine falcons (passage birds only) may be taken September 20-October 20 only by general or master falconers in possession of a valid peregrine falcon trapping permit;

i. may take no more than two raptors or eggs from the wild in the calendar year;

j. may possess and propagate federally threatened or endangered raptor species only if authorized by the USFWS Regional Migratory Bird Permit Office to do so;

k. may take a raptor listed by the USFWS as endangered or threatened from the wild for propagation purposes only if authorized by the department and in possession of a USFWS endangered species permit authorizing this activity;

l. may use falconry training or conditioning practices such as, but not limited to, creance (tethered) flying, lures, balloons, or kites in training or conditioning captive-bred progeny of raptors legally possessed;

m. may use captive-bred offspring less than one year old for falconry as a means of training progeny of raptors legally possessed.

6. Temporary Permit

a. Non-U.S. residents with experience in falconry must correctly answer at least 80 percent of the questions on the Louisiana falconry exam to qualify for a permit. The department will review the applicant's documented experience and issue a falconry permit consistent with that experience. The falconer's facilities and equipment must pass an inspection before the falconer obtains a bird.

b. Temporary permit holders may fly legally imported falconry raptors provided the raptors are exported when the falconer leaves the U.S., and that two functioning radio transmitters are attached when the raptors are flown free.

c. Temporary permit holders may not take a raptor from the wild for use in falconry.

7. Taking Falconry Raptors to Another Country to use in Falconry Activities

a. A Louisiana falconry permittee may export legally possessed falconry birds to another country to use in falconry in accordance with the regulations of the destination country and all state and federal regulations governing import/export.

8. Updating a Falconry Permit after a Move

a. A falconer who moves to a new state, tribe or territory with falconry birds must inform the falconry regulatory authorities in each jurisdiction of the address change within 30 days.

b. A falconer moving from another state to Louisiana with the intent to establish residency must obtain a

Louisiana falconry permit with 120 days. The falconer may bring his or her lawfully possessed birds into the state in the interim.

9. Reinstatement of a Lapsed Falconry Permit

a. If a falconer's permit has lapsed for fewer than five years, it may be reinstated at the level the falconer held previously if he or she provides proof of certification at that level.

b. If a permit has lapsed for five years or longer, it may be reinstated at the level previously held if the applicant correctly answers at least 80 percent of the questions on the falconry test and the applicant's facilities and equipment pass an inspection before the permit is reinstated and before possessing a bird.

10. Permit to practice falconry at an appropriate level for experienced falconers who are new residents in the United States.

a. U.S. residents with falconry experience in another country may be issued a falconry permit commensurate with documented experience if appropriate documentation is provided detailing the applicant's experience, the applicant correctly answers at least 80 percent of the questions on the Louisiana falconry test, and the applicant's facilities and equipment pass an inspection before a permit is issued.

D. Facilities for Housing Raptors

1. Raptors held under falconry permit shall be kept in humane and healthful conditions. Housing facilities shall provide protection from adverse weather, predators and domestic animals.

2. All raptor housing facilities must pass an inspection by department personnel or others authorized by the department before a license will be issued.

3. Each facility must have at least one suitable perch for each raptor and at least one opening for sunlight.

4. Untethered raptors may be held in the same facility if they are at molting weight and compatible with each other.

5. Raptor housing facilities must provide enough room for the raptor to fly if untethered or, if tethered, to fully extend its wings or bate without damaging its feathers or contacting other raptors.

6. Facilities must contain a suitable water container, and fresh, clean water shall be provided unless weather, a medical condition, or other circumstance requires the temporary denial of water.

7. A single facility that meets the requirements of both indoor and outdoor facilities is acceptable.

8. An indoor facility must be large enough to allow easy access for the care and feeding of raptors housed therein. If raptors are free-lofted, all walls that are not solid must be protected on the inside. Suitable materials may include vertical bars spaced narrower than the width of the body of the smallest raptor housed in the enclosure. However, heavy-duty netting or other such materials may be used to cover the walls or roof of the enclosure. Acceptable indoor facilities include shelf perch enclosures where raptors are tethered side by side. Other innovative housing systems are acceptable if they provide the enclosed raptors with protection and maintain healthy feathers. If falconry raptors are housed inside the home, the falconer does not need to modify windows or other openings of the structure provided the raptor is kept tethered.

9. An outdoor facility must be totally enclosed, and may be made of heavy-gauge wire, chain-link fencing, heavy-duty plastic mesh, slats, pipe, wood, or other suitable material. It must be covered and have at least a covered perch to protect a raptor held in it from predators and weather. The facility must be large enough that the bird cannot strike the enclosure when flying from the perch.

10. A falconer shall notify the department within five business days of relocating a raptor housing facility to a new location.

11. A falconer shall allow department personnel to inspect the facilities and/or raptors without advance notice.

E. Falconry Facilities on Property not owned by the Licensee

1. Falconry facilities may be on property owned by another person. Regardless of location, falconry facilities must meet the requirements described in this Rule.

2. If the facilities are on property owned by another person, the licensee must submit a signed and dated statement from the property owner authorizing department personnel to inspect the facilities and/or raptors without advance notice.

F. Equipment

1. At the time of the facility inspection, each applicant shall have in possession the following equipment:

a. at least one pair of jesses constructed of pliable, high-quality leather or suitable synthetic material, or materials and equipment to make them;

b. at least one flexible, weather-resistant leash and one strong swivel of acceptable falconry design;

c. at least one weathering-area perch of acceptable design for each raptor;

d. a suitable bath container;

e. a reliable scale or balance suitable for weighing the raptors, graduated in increments of not more than 1/5 ounce or 5 grams.

2. When being transported, a falconry raptor must have a suitable perch and protection from extreme temperatures, wind and excessive disturbance.

G. Care of Falconry Raptors by another Falconry Licensee. Any falconer may care for the birds of another falconer at either falconer's facilities. The falconer providing the care must be given a signed and dated statement from the owner of the birds describing the time period of temporary care and what activities are authorized. The falconer providing the care must also be given a copy of the USFWS Form 3-186A showing that the absent owner is the possessor of the raptors. Temporary care may not exceed 120 consecutive calendar days. Under extenuating circumstances such as illness, military service or family emergency, the department may authorize indefinite extension of temporary care.

H. Care of Falconry Raptors by Someone without a Falconry License

1. A person without a falconry permit may care for a licensed falconer's raptors at the licensee's facilities for up to 45 consecutive days. The raptors must remain in the facilities and the caretaker may not fly them for any reason. Care may be extended indefinitely under extenuating circumstances such as illness, military service or family emergency if authorized in writing by the department.

I. Transfer of Falconry Raptors if a Licensee Dies

1. A surviving spouse, executor, administrator, or other legal representative of a deceased falconer may transfer any bird held by the deceased falconer to another falconer within 90 days of the death of the falconer. After 90 days, disposition is at the discretion of the department.

J. Banding or Tagging Raptors used in Falconry

1. If a falconer takes a northern goshawk (*Accipiter gentilis*), Harris's hawk (*Parabuteo unicinctus*), peregrine falcon, or gyrfalcon (*Falco rusticolus*) from the wild or acquires one from a rehabilitator, the raptor must be banded with a permanent, non-reusable, numbered USFWS leg band provided by the department upon request. Falconers may purchase and implant an ISO (International Organization for Standardization) compliant (134.2 kHz) microchip in addition to the band. The falconer must report the band number when reporting acquisition of the bird. Within 10 days from the day on which the bird is taken from the wild, it must be reported by entering the required information, including band number, in the electronic database on the appropriate USFWS website. A falconer may request an appropriate band in advance of any effort to capture a raptor. A raptor captured from the wild may not be banded with a seamless numbered band.

2. A raptor bred in captivity must be banded with a seamless metal band. If a seamless band is lost or removed from a captive bred bird, it must be reported within 10 days and a request made for a non-reusable USFWS replacement band. Immediately upon re-banding the bird, the required information, including the band number, must be entered into the electronic database on the appropriate USFWS website.

3. If a band must be removed or is lost from a wild raptor, the falconer must report this removal or loss to the department within five days and request a non-reusable replacement band. The falconer must file an electronic report within 10 days of re-banding at the USFWS website.

4. Birds with documented health or injury problems caused by bands may be exempted in writing from banding by the department once documentation is reviewed. If an exemption is issued, the falconer must keep the written exemption in his/her possession when flying or transporting the exempted bird. If that bird is a wild northern goshawk, Harris's hawk, peregrine falcon, or gyrfalcon, the band must be replaced with an ISO-compliant (134 kHz) microchip obtained from the department.

5. Raptor bands shall not be altered, defaced or counterfeited except that a falconer may remove the rear tab and smooth the surface without affecting the integrity or numbering of the band.

K. Additional Regulations on Taking, Transporting and Possessing of Raptors for Falconry

1. A falconer who resides in another state may take raptors from the wild in Louisiana if he or she has in possession a valid falconry permit/license from his or her state of residence and if the falconer abides by all Louisiana and federal falconry regulations. If a raptor is taken in Louisiana, the non-resident falconer must complete a Louisiana raptor harvest report form (available on the department web site) and submit it to the department within 10 days of acquiring the raptor. Non-resident falconers may

not take peregrine falcons, bald eagles or swallow-tailed kites in Louisiana.

2. A falconer shall not intentionally capture a raptor that he or she is not authorized to possess. Any bird captured that is not authorized for possession shall be released immediately at the site of capture.

3. Falconers who capture raptors that are wearing research bands, research markings or transmitters shall report all band numbers and other markings to the USGS Bird Banding Laboratory.

4. Any falconer is authorized to capture a raptor trapped inside a building. The bird shall be released immediately into the wild unless it is sick or injured, in which case it shall be transferred to a licensed rehabilitator within 24 hours.

5. A falconer may recapture any raptor wearing falconry equipment and return it to the proper owner. A captured raptor that is wearing falconry equipment must be reported to the department within five days. It does not count against the permittee's take or possession limit while temporarily in possession.

6. Take of raptors from the wild shall be reported electronically within 10 days by entering the required information into the electronic database via the appropriate USFWS website.

7. Falconers must abide by state, tribal, territorial, and federal laws and restrictions regarding take, possession, and transfer or loss of any wild raptor.

8. No permittee may take more than two raptors from the wild per calendar year for use in falconry.

9. General and master falconers may take no more than one bird of a federally threatened species from the wild each year. A valid federal endangered species permit must be obtained prior to taking a threatened bird.

10. If a permittee is present at the capture site for the taking of a raptor from the wild, even if another person actually captures the bird, the permittee is considered the person who removes the bird from the wild and must report the take by entering the required information into the electronic database via the appropriate USFWS website, within 10 days of the capture of the bird. This will count as one of the two wild raptors the permittee is allowed to take within the calendar year.

11. A general or master falconer may take a raptor from the wild for another licensee who is not present during the taking, report the acquisition, and then transfer it to the other licensee. The general or master falconer who removed the raptor from the wild must report the take within 10 days, even if it was promptly transferred to another permittee. This will count as one of the two wild raptors that the falconer who took the bird is allowed during that calendar year.

12. A falconer may acquire a raptor from a licensed rehabilitator if the falconer is authorized to possess that species of bird. A raptor acquired from a rehabilitator will count as a raptor taken from the wild and shall be reported within five days of acquisition.

13. A raptor injured during capture may be kept and properly reported as a falconry acquisition within 10 days of capture and treated by a veterinarian or licensed wildlife rehabilitator. Alternatively, the raptor may be turned over to a veterinarian, wildlife rehabilitator or department biologist

if he or she agrees to accept it, in which case it will not count against the falconer's take or possession limit. In either case, the falconer who captured the bird is responsible for the costs of care and rehabilitation of the bird.

14. Any time a permittee acquires, transfers, re-bands or microchips a raptor or has a raptor stolen or loses a raptor to the wild and does not recapture it within 30 days, or a raptor dies, the change must be properly reported via the USFWS website within 10 days.

15. Falconers may transfer, sell, purchase or barter captive bred raptors that are marked with seamless bands to other licensees who are authorized to possess them. Falconers may not purchase, sell, trade or barter wild raptors or captive bred raptors not marked with seamless bands, but they may transfer them to other permittees.

16. Falconers may transfer wild raptors to other falconers authorized to possess them.

17. A falconer may transfer a wild raptor to other permit types after the bird has been used in falconry for two years (or one year for a sharp-shinned hawk—*Accipiter striatus*), a Cooper's hawk (*Accipiter cooperii*), a merlin (*Falco columbarius*), or an American kestrel. The falconer must provide a copy of the 3-186-A form documenting the transfer to the federal migratory bird permit office that administers the other permit type in addition to filing an electronic report. Falconers may transfer a wild raptor to another permit type in less time, provided the bird has been injured, is no longer suitable for use in falconry, and the case is documented in writing by a veterinarian or properly permitted wildlife rehabilitator. Copies of the 3-186-A and the letter from the veterinarian or rehabilitator must be submitted to the federal office that administers that permit type in addition to filing an electronic report.

18. Falconry raptors may be used for captive propagation without transferring them to a federal raptor propagation permit provided the birds are banded and used for this purpose fewer than eight months in a year and that the person propagating the raptors possesses a federal raptor propagation permit.

19. The theft of a raptor from a permittee must be reported to the department and to the USFWS regional law enforcement office within 48 hours of discovery of the theft of the bird.

20. Falconers must keep copies of all electronic database submissions documenting take, transfer, loss, re-banding or microchipping of each falconry raptor for five years after the bird was transferred, lost or died.

21. Falconers must carry legible copies of their falconry permits with them whenever conducting falconry activities away from their falconry facilities. This includes trapping, transporting, flying, working or hunting with raptors and traveling through other states, tribal lands, or territories. Falconers from other states may transport their raptors through Louisiana without any additional permits as long as they have legible copies of their falconry permits/licenses in their possession. Falconers residing in other states may bring their raptors to Louisiana for educational purposes without any additional permits as long as they are in Louisiana less than 120 consecutive days and have a valid falconry permit/license in their possession.

22. Falconers hunting with raptors in Louisiana must abide by applicable hunting regulations including possession of hunting licenses, stamps, and permits.

L. Hybrids. When flown free, including when at hack, a hybrid raptor must have attached at least two functioning radio transmitters for use in locating the bird.

M. Use of Eagles in Falconry

1. With authorization for eagles from the department, master falconers may possess up to a total of three eagles of the following species: golden eagle, white-tailed eagle, or Steller's sea-eagle. A golden eagle, white-tailed eagle, or Stellar's sea-eagle counts as a bird to be included under the falconer's possession limit. Master falconers who wish to possess native eagles or sea-eagles for use in falconry must request and receive written authorization for eagles or sea-eagles prior to obtaining one and must submit the following documentation:

a. a letter detailing experience in handling large raptors, including information about the species handled and the type and duration of the activity;

b. at least two letters of reference from people with experience handling and/or flying large raptors such as eagles, sea-eagles, ferruginous hawks (*Buteo regalis*), northern goshawks, or great horned owls. Each must contain a concise history of the author's experience with large raptors, which can include, but is not limited to, handling of raptors held by zoos, rehabilitating large raptors, or scientific studies involving large raptors. Each letter must also assess the falconer's ability to care for eagles or sea-eagles and fly them in falconry.

2. A master falconer authorized by the department to possess a golden eagle may capture one under the provisions in 50 CFR 21.29 and 50 CFR 22 for taking a golden eagle for falconry.

N. Releasing Raptors into the Wild

1. Wild raptors may be permanently released at any time.

2. No hybrids or exotics of any kind may be permanently released in Louisiana.

3. Captive-bred raptors may be permanently released to the wild only with written authorization from the department and only after a suitable hacking period in a suitable location and at an appropriate time of year. The seamless band must be left on the bird. The release must be properly reported to the department and to the USFWS within 10 days of the permanent release.

O. Hacking. General and master falconers may hack falconry raptors. Hacking is not allowed near a nesting area of a federally threatened or endangered animal or in any location where the raptor is likely to harm a federally listed threatened or endangered animal. Falconers may contact the department for information on nesting locations of federal listed species prior to hacking any falconry raptor.

P. Use of Native Raptors in Conservation Education Programs

1. General and master falconers may use their birds in conservation education programs presented in public venues. Apprentice falconers may do so only when supervised by a general or master falconer.

2. Fees may be charged for such educational programs but only to the extent necessary to recover costs for participating.

3. Education programs must relate to the biology, ecological roles and conservation needs of raptors and other migratory birds.

Q. Other Educational uses of Native Raptors

1. Falconers may allow their birds to be photographed or filmed to make movies or other sources of information on the practice of falconry or on the biology, ecological roles and conservation needs of raptors and other migratory birds but may not be paid for doing so.

2. Falconers may not use their birds to make movies, commercials or engage in other commercial ventures that are not related to falconry.

3. Falconers may use their birds to promote or endorse products or endeavors related to falconry provided the falconer is not paid or otherwise compensated for such usage.

R. Assisting in the Rehabilitation of Raptors. General and master falconers may assist properly licensed migratory bird rehabilitators in preparing rehabilitated raptors for permanent release to the wild. While doing so, the falconer may keep the bird in his or her facility while the bird remains on the rehabilitator's permit. The rehabilitator must provide the falconer with a document that identifies the bird and states that the falconer is assisting in the bird's rehabilitation. All rehabilitation raptors shall be released or returned to the rehabilitator within 180 days, unless written authorization is obtained from the department to condition them for a longer period.

S. Abatement Activities. Master falconers must have a valid federal abatement permit to use raptors in abatement activities. General falconers may do so only as a sub-committee of the holder of the abatement permit.

T. Additional Falconry Practices

1. Falconry practices, such as, but not limited to, the use of creance flying, lures, balloons, or kites in training or conditioning falconry raptors is permissible.

2. Falconry birds may be used to take any bird species for which a depredation order is in place in accordance with the conditions of the applicable depredation order. The falconer must not be paid or otherwise compensated for doing so.

U. Accidental Take of Prey. If a prey item is killed by a falconry bird unintentionally, including an animal taken outside of a regular hunting season, the falconer may allow the raptor to feed on the kill in the field, but the animal may not be taken into possession. Accidental take of any federally listed threatened or endangered species must be reported to the USFWS Ecological Services field office and the department.

V. Possession and Disposition of Molted Feathers

1. Falconers may possess flight feathers for each raptor species in possession or previously held.

2. Falconers may receive flight feathers from other falconers, wildlife rehabilitators or propagators in the United States and may give feathers to them or to other permittees allowed to possess them. Feathers may not be bought, sold or bartered. When the licensee's permit expires or is revoked, all remaining feathers shall be donated to someone authorized to possess feathers or destroyed. Molted

primaries, secondaries and rectrices from golden eagles must be collected and either retained or sent to the National Eagle Repository.

W. Disposition of Carcasses. The carcass of a falconry bird may be donated to someone authorized to possess it. If the bird was banded or microchipped prior to its death, the bird may be kept so the feathers are available for imping. The carcass may be mounted by a taxidermist for use in conservation programs. The band or microchip must remain in place. Carcasses not kept or donated shall be burned, buried or otherwise destroyed. Golden eagle carcasses must be sent to the National Eagle Repository.

X. Penalties. Violation of this rule constitutes a class 2 violation as provided in R.S. 56:115. Additionally, a person who is convicted of a violation of these rules may be ineligible for a falconry permit for a period of up to three years from the date of the conviction.

Y. Falconers are also responsible for conducting their activities in accordance with federal regulations that apply to falconry and are found in 50 CFR 21.29.

AUTHORITY NOTE: Promulgated in accordance with R.S. 56:6.

HISTORICAL NOTE: Promulgated by the Department of Wildlife and Fisheries, Wildlife and Fisheries Commission, LR 4:299 (August 1978), LR 39:

The secretary of the Department of Wildlife and Fisheries is authorized to take any and all necessary steps on behalf of the commission to promulgate and effectuate this Notice of Intent and the final Rule, including, but not limited to, the filing of the Fiscal and Economic Impact Statement, the filing of the Notice of Intent and final Rule and the preparation of reports and correspondence to other agencies of government.

Family Impact Statement

In accordance with Act #1183 of the 1999 Regular Session of the Louisiana Legislature, the Department of Wildlife and Fisheries, Wildlife and Fisheries Commission hereby issues its Family Impact Statement in connection with the preceding Notice of Intent. This Notice of Intent will have no impact on the six criteria set out at R.S. 49:972(B).

Public Comments

Interested persons may submit written comments on the proposed Rule to Mr. Kenny Ribbeck, Wildlife Division, Department of Wildlife and Fisheries, P.O. Box 98000, Baton Rouge, LA 70898-9000, no later than 4:30 p.m., December 6, 2012.

Ann L. Taylor
Chairman

**FISCAL AND ECONOMIC IMPACT STATEMENT
FOR ADMINISTRATIVE RULES**

RULE TITLE: Falconry

I. ESTIMATED IMPLEMENTATION COSTS (SAVINGS) TO STATE OR LOCAL GOVERNMENT UNITS (Summary)

The proposed rule change will have no impact on state or local governmental units expenditures. The proposed rule merges existing state falconry rules and federal falconry rules. Under the existing rules, the department has administered the falconry program by conducting inspections, issuing permits and handling renewals.

The Department of Wildlife and Fisheries and Wildlife and Fisheries Commission has regulated falconry in partnership

with the U.S. Fish and Wildlife Service since 1978 when the existing rules were adopted. A joint state/federal falconry permit was issued to falconers that met the requirements and falconers were also required to have a game breeder license issued by the Department of Wildlife and Fisheries. Falconers were governed by both state and federal falconry rules. The U.S. Fish and Wildlife Service has notified the states that they will end the federal falconry permitting program on January 1, 2014 (CFR 21.29(b)). In order for the practice of falconry to continue in Louisiana, the state must establish U.S. Fish and Wildlife Service approved falconry rules by January 1, 2014.

II. ESTIMATED EFFECT ON REVENUE COLLECTIONS OF STATE OR LOCAL GOVERNMENTAL UNITS (Summary)

There will be no effect on revenue collections to state or local governmental units as a result of the proposed rule change.

III. ESTIMATED COSTS AND/OR ECONOMIC BENEFITS TO DIRECTLY AFFECTED PERSONS OR NONGOVERNMENTAL GROUPS (Summary)

There is no estimated cost and/or benefit to directly affected persons or non-governmental groups.

IV. ESTIMATED EFFECT ON COMPETITION AND EMPLOYMENT (Summary)

The proposed rule change is anticipated to have no effect on competition and employment in the public and private sectors.

Lois Azzarello
Undersecretary
1210#033

Evan Brasseaux
Staff Director
Legislative Fiscal Office

NOTICE OF INTENT

**Workforce Commission
Office of Workers' Compensation**

Electronic Medical Billing and Payment Companion Guide
(LAC 40:I:305 and 306)

Notice is hereby given, in accordance with R.S. 49:950, et seq., that the Louisiana Workforce Commission, Office of Workers' Compensation, pursuant to the authority vested in the Director of the Office of Workers' Compensation by R.S. 23:1310.1 and in accordance with applicable provisions of the Administrative provisions Act, proposes to amend LAC 40:I:305,306. The amendments include:

Title 40

LABOR AND EMPLOYMENT

Part I. Workers' Compensation Administration

Subpart 1. General Administration

Chapter 3. Electronic Billing

§305. Formats for Electronic Medical Bill Processing

A. - F. ...

G. The OWCA shall develop the "Electronic Medical Billing and Payment Companion Guide" found in Section 306 of this chapter.

AUTHORITY NOTE: Promulgated in accordance with R.S. 23:1310.1.

HISTORICAL NOTE: Promulgated by the Louisiana Workforce Commission, Office of Workers Compensation Administration, LR 37:3543 (December 2011), amended by the Louisiana Workforce Commission, Office of Workers Compensation Administration, LR 39:

**§306. Electronic Medical Billing and Payment
Companion Guide**

A. Introduction and Overview

1. HIPAA

a. The Administrative Simplification Act provisions of the Federal Health Insurance Portability and Accountability Act of 1996 (HIPAA, Title II) include requirements that national standards for electronic health care transactions and national identifiers for Health Care Providers (Provider), Health Plans, and Employers be established. These standards were adopted to improve the efficiency and effectiveness of the nation's health care system by encouraging the widespread use of electronic data interchange in health care. Additional information regarding the formats adopted under HIPAA is included in Chapter 2. Although workers compensation is excluded from HIPAA, these national standards encourage use of electronic medical billing for workers compensation claims in Louisiana.

2. Louisiana Workforce Commission, Office of Workers' Compensation-Electronic Billing

a. Louisiana Workforce Commission, Office of Workers' Compensation, LSA-R.S. 23:1203.2 mandates that carriers accept electronic bills for medical goods and services. Payers other than carriers (self-insured employers or self-insured funds) may participate in electronic medical billing but are not mandated as of this time. The rules also provide that the regulations which establish electronic billing rules be consistent with HIPAA to the extent possible. If participating in electronic medical billing, the health care provider, health care facility, or third-party biller/assignee shall use the HIPAA adopted electronic transaction formats outlined in Title 40:I:Chapter 3 to submit medical or pharmacy bills to the appropriate payer associated with the employer of the injured employee to whom the services are provided.

b. In workers' compensation, the payer is the party responsible for providing benefits on behalf of the employer of the injured employee to whom the services are due. The payer, or its authorized agent, is to validate the Electronic Data Interchange (EDI) file according to the guidelines provided in the prescribed national standard format implementation guide, this companion guide, and the jurisdictional data requirements. Problems associated with the processing of the ASC X12 Health Care Claim (837) EDI file are to be reported using acknowledgment transactions described in this companion guide. Problems associated with the processing of the NCPDP Telecommunications D.0 bills are reported via the reject response transactions described in this companion guide. If mutually agreed upon, the payer will use the HIPAA-adopted electronic transaction formats to report explanations of payments, reductions, and denials to the health care provider, health care facility, or third-party biller/assignee. These electronic transaction formats include the ASC X12N/005010X221A1, Health Care Claim Payment/Advice (835), and the NCPDP Telecommunication D.0 Paid response transaction or other formats pursuant to Title 40:I:Chapter 3.

c. Health care providers, health care facilities, or third-party biller/assignees, payers, clearinghouses, or other electronic data submission entities shall use this guideline in conjunction with the HIPAA-adopted ASC X12 Type 3 Technical Reports (implementation guides) and the NCPDP Telecommunication Standard Implementation Guide Version D.0. The ASC X12 Type 3 Technical Reports (implementation guides) can be accessed by contacting the Accredited Standards Committee (ASC) X12, <http://store.x12.org/store/>. The NCPDP Telecommunication Standard Implementation Guide Version D.0 is available from NCPDP at www.ncdp.org.

d. This guide outlines jurisdictional procedures necessary for engaging in Electronic Data Interchange (EDI) and specifies clarifications where applicable. When coordination of a solution is required, Louisiana Workforce Commission, Office of Workers' Compensation will work with the IAIABC EDI Medical Committee and Provider to Payer Subcommittee to coordinate with national standard setting organizations and committees to address workers' compensation needs.

B. Louisiana Workforce Commission, Office of Workers' Compensation Requirements

1. Compliance. If a billing entity chooses to submit bills electronically, it must also be able to receive an electronic response from the payer pursuant to Title 40:I. Chapter 3. The electronic responses include electronic acknowledgments (required) and electronic remittance advices (Explanation of Review) (where mutually agreed upon). Electronic billing rules allow for providers and payers to use agents to meet the requirement of electronic billing, but these rules do not mandate the method of connectivity, or the use of, or connectivity to, clearinghouses or similar types of vendors. Nothing in this document prevents the parties from utilizing Electronic Funds Transfer (EFT) to facilitate payment of electronically submitted bills. Use of EFT is governed by RS 23: 1203.2.B. (2) and is not a pre-condition for electronic billing. If covered by RS 23: 1203.2, health care providers, health care facilities, third-party biller/assignees, and payers must be able to exchange electronic bills in the prescribed standard formats and may exchange data in non-prescribed formats by mutual agreement. All jurisdictionally-required data content must be present in mutually agreed upon formats.

2. Agents. Electronic billing rules allow for health care providers and payers to use agents to accomplish the requirement of electronic billing. Payers and health care providers are responsible for the acts or omissions of their agents executed in the performance of services for their client's payer or health care provider.

3. Privacy, Confidentiality, and Security. Health care providers, health care facilities, third-party biller/assignees, payers, and their agents must comply with all applicable Federal and Louisiana Acts, Codes, or Rules related to the privacy, confidentiality, security or similar issues.

4. National Standard Formats.

a. The national standard formats for billing, remittance, and acknowledgments are those adopted by the Federal Department of Health and Human Services rules (45 CFR Parts 160 and 162). The formats adopted under Louisiana Workforce Commission, Office of Workers'

Compensation, RS 23: 1203.2 that are aligned with the current Federal HIPAA implementation include:

- i. ASC X12N/005010X222A1 Health Care Claim: Professional (837);
- ii. ASC X12N/005010X223A2 Health Care Claim: Institutional (837);
- iii. ASC X12N/005010X224A2 Health Care Claim: Dental (837);
- iv. ASC X12N/005010X221A1 Health Care Claim Payment/Advice (835);
- v. ASC X12N/005010X212 Health Care Claim Status Request and Response (276/277);
- vi. ASCX12N005010TA1; Interchange Acknowledgment
- vii. ASCX12C005010X231 Implementation Acknowledgment for Health Care Insurance (999);
- viii. ASCX12N005010X214 Health Care Claim Acknowledgment (277);
- ix. NCPDP Telecommunication Standard Implementation Guide Version D.0; and
- x. NCPDP Batch Standard Implementation Guide 1.2.

b. These acknowledgment formats and the attachment format have not been adopted in the current HIPAA rules but are also based on ASC X12 standards.

i. The ASC X12N/005010X213 Request for Additional Information (277) is used to request additional attachments that were not originally submitted with the electronic medical bill.

ii. The ASC X12N/005010X210 Additional Information to Support a Health Care Claim or Encounter (275) is used to transmit electronic documentation associated with an electronic medical bill. The 005010X210 can accompany the original electronic medical bill, or may be sent in response to a 005010X213 Request for Additional Information.

c. The NCPDP Telecommunication Standard Implementation Guide Version D.0 contains the corresponding request and response messages to be used for pharmacy transactions.

5. Louisiana Workforce Commission, Office of Workers' Compensation Prescribed Formats

Format	Corresponding Paper Form	Function
005010X222A1	CMS-1500	Professional Billing
005010X223A2	UB-04	Institutional/Hospital Billing
005010X224A2	ADA-2006	Dental Billing
NCPDP D.0 and Batch 1.2	NCPDP WC/PC UCF	Pharmacy Billing
005010X221A1	None	Explanation of Review (EOR)
TA1 005010	None	Interchange Acknowledgment
005010X231	None	Transmission Level Acknowledgment
005010X214	None	Bill Acknowledgment

6. ASC X12 Ancillary Formats

a. Other formats not adopted by Louisiana Workforce Commission, Office of Workers' Compensation

rule are used in ancillary processes related to electronic billing and reimbursement. The use of these formats is voluntary, and the companion guide is presented as a tool to facilitate their use in workers' compensation.

Format	Corresponding Process	Function
005010X210	Documentation/Attachments	Documentation/Attachments
005010X213	Request for Additional Information	Request for Medical Documentation
005010X214	Health Claim Status Request and Response	Medical Bill Status Request and Response

7. Companion Guide Usage

a. Louisiana Workforce Commission, Office of Workers' Compensation workers' compensation implementation of the national standard formats aligns with HIPAA usage and requirements in most circumstances. This jurisdictional companion guide is intended to convey information that is within the framework of the ASC X12 Type 3 Technical Reports (Implementation Guides) and NCPDP Telecommunication Standard Implementation Guide Version D.0 adopted for use. This jurisdictional companion guide is not intended to convey information that in any way exceeds the requirements or usages of data expressed in the ASC X12 Type 3 Technical Reports (Implementation Guides) or NCPDP Telecommunication Standard Implementation Guide Version D.0. The jurisdictional companion guide, where applicable, provides additional instruction on situational implementation factors that are different in workers' compensation than in the HIPAA implementation.

b. When the workers' compensation application situation needs additional clarification or a specific code value is expected, the companion guide includes this information in a table format. Shaded rows represent "segments" in the ASC X12 Type 3 Technical Reports (Implementation Guides). Non-shaded rows represent "data elements" in the ASC X12 Type 3 Technical Reports (Implementation Guides). An example is provided in the following table.

Loop	Segment or Element	Value	Description	Louisiana Workforce Commission, Office of Workers' Compensation Instructions
2000B	SBR		Subscriber Information	In workers' compensation, the Subscriber is the Employer.
	SBR04		Group or Plan Name	Required when the Employer Department Name/Division is applicable and is different than the Employer reported in Loop 2010BA NM103.
	SBR09	WC	Claim Filing Indicator Code	Value must be 'WC' to indicate workers' compensation bill.

c. Detailed information explaining the various components of the use of loops, segments, data elements, and conditions can be found in the appropriate ASC X12 Type 3 Technical Reports (Implementation Guides).

d. The ASC X12 Type 3 Technical Reports (Implementation Guides) also include elements that do not relate directly to workers' compensation processes, for example, coordination of benefits. If necessary, the identification of these loops, segments, and data elements can be described in the trading partner agreements to help ensure efficient processing of standard transaction sets.

8. Description of ASC X12 Transaction Identification Numbers. The ASC X12 Transaction Identification requirements are defined in the appropriate ASC X12 Type 3 Technical Reports (Implementation Guides), available through the Accredited Standards Committee (ASC) X12, <http://store.x12.org>. The Louisiana Workforce Commission, Office of Workers' Compensation has provided the following additional information regarding transaction identification number requirements.

a. Sender/Receiver Trading Partner Identification. Workers' compensation standards require the use of the Federal Employer Identification Number (FEIN) or other mutually agreed upon identification numbers to identify Trading Partners (sender/receiver) in electronic billing and reimbursement transmissions. Trading Partners will exchange the appropriate and necessary identification numbers to be reported based on the applicable transaction format requirements.

b. Payer Identification. Payers and their agents are also identified through the use of the FEIN or other mutually agreed upon identification number. Payer information is available through direct contact with the payer. The Payer Identification information is populated in Loop 2010BB for 005010X222A1, 005010X223A2, and 005010X224A2 transactions.

i. Health care providers will need to obtain payer identification information from their connectivity trading partner agent (i.e. clearinghouses, practice management system, billing agent and/or other third party vendor) if they are not directly connecting to a payer.

c. Health Care Provider Identification. Health Care Provider roles and identification numbers are addressed extensively in the ASC X12 Type 3 Technical Reports (Implementation Guides). However, it is noted that in the national transaction sets most health care providers are identified by the National Provider Identification number (NPI), and secondary identification numbers are generally not transmitted.

d. Injured Employee Identification. The injured employee is identified by name, Social Security Number, date of birth, date of injury, and workers' compensation claim number (see below).

i. The injured Employee (patient's) Identification Number is submitted using the Property and Casualty Patient Identifier REF segment in Loop 2010CA.

e. Claim Identification. The workers' compensation claim number assigned by the payer is the claim identification number. This claim identification number is reported in the REF segment of Loop 2010CA, Property and Casualty Claim Number.

i. The ASC X12N Technical Report Type 3 (Implementation Guides) instructions for the Property and Casualty Claim Number REF segments require the health care provider, health care facility, or third-party biller/assignee to submit the claim identification number in the 005010X222A1, 005010X223A2 and 005010X224A2 transactions.

f. Bill Identification. The ASC X12N Technical Report Type 3 (Implementation Guides) refers to a bill as a “claim” for electronic billing transactions. This Louisiana Workforce Commission, Office of Workers’ Compensation companion guide refers to these transactions as “bill” because in workers’ compensation, a “claim” refers to the full case for a unique injured employee and injury. The health care provider, health care facility, or third-party biller/assignee, assigns a unique identification number to the electronic bill transaction. For 005010X222A1, 005010X223A2, and 005010224A2 transactions, the bill transaction identification number is populated in Loop 2300 Claim Information CLM Health Claim Segment CLM01 Claim (Bill) Submitter’s Identifier data element. This standard HIPAA implementation allows for a patient account number but strongly recommends that submitters use a completely unique number for this data element on each individual bill.

g. Document/Attachment Identification. The 005010X210 is the standard electronic format for submitting electronic documentation and is addressed in a later chapter of the Louisiana Workforce Commission, Office of Workers’ Compensation Electronic Billing and Payment Companion Guide. Bills containing services that require supporting documentation as defined Louisiana Workforce Commission, Office of Workers’ Compensation, R.S. 23:1203.2 must be properly annotated in the PWK Attachment Segment. Bill transactions that include services that require documentation and are submitted without the PWK annotation documentation will be rejected. Documentation to support electronic medical bills may be submitted by facsimile (fax), electronic mail (email), electronic transmission using the prescribed format, or by a mutually agreed upon format between providers and payers. Documentation related to the electronic bill must be submitted within five business days of submission of the electronic medical bill and must identify the following elements:

- i. patient name (injured employee);
- ii. employer name (if available);
- iii. payer name;
- iv. date of service
- v. date of injury
- vi. claim number (if known);
- vii. unique attachment indicator number.

h. The PWK Segment and the associated documentation identify the type of documentation through the use of ASC X12 standard Report Type Codes. The PWK Segment and the associated documentation also identify the method of submission of the documentation through the use of ASC X12 Report Transmission Codes. A unique Attachment Indicator Number shall be assigned to all documentation. The Attachment Indicator Number populated on the document shall include the Report Type Code, the Report Transmission Code, the Attachment Control Qualifier

(AC) and the Attachment Control Number. For example, operative note (report type code OB) sent by fax is identified as OBFXAC12345. The combination of these data elements will allow a claim administrator to appropriately match the incoming attachment to the electronic medical bill.

9. Payer Validation Edits. Payers may apply validation edits based on Louisiana Workforce Commission, Workers’ Compensation Office of Workers’ Compensation eBill Regulations, Louisiana Electronic Medical Billing and Payment Companion Guide and ASC X12N Technical Reports Type 3 (TR3s) requirements. Payers use the 005010X214 transaction, referred to in this companion guide as an Acknowledgment, to communicate transaction (individual bill) rejections for ASC X12-based electronic medical bills. Error rejection codes are used to indicate the reason for the transaction rejection.

10. Description of Formatting Requirements. The ASC X12 formatting requirements are defined in the ASC X12 Type 3 Technical Reports (Implementation Guides), Appendices A.1, available through the Accredited Standards Committee (ASC) X12, <http://store.x12.org>. The Louisiana Workforce Commission, Office of Workers’ Compensation has provided the following additional information regarding formatting requirements:

a. The NCPDP Telecommunication D.0 formatting requirements are defined in the NCPDP Telecommunication Standard Implementation Guide Version D.0, available at <http://www.ncdp.org>.

11. ASC X12 Hierarchical Structure. For information on how the ASC X12 Hierarchical Structure works, refer to Section 2.3.2.1 HL Segment of the ASC X12 Type 3 Technical Reports (Implementation Guides), available through the Accredited Standards Committee (ASC) X12, <http://store.x12.org>.

12. Description of ASC X12Transmission/Transaction Dates. The ASC X12 required Transmission/Transaction Dates are defined in the ASC X12 Type 3 Technical Reports (Implementation Guides) available through the Accredited Standards Committee (ASC) X12, <http://store.x12.org>. The Louisiana Workforce Commission, Office of Workers’ Compensation has provided additional information regarding specific transmission/transaction identification requirements.

13. Date Sent/Invoice Date. In the manual paper medical bill processing model, the paper bill includes a date the bill was generated, to verify timely filing. For electronic billing, the Invoice Date is the Date Sent, which is reflected in the Interchange Control Header ISA Segment Interchange Date. The date in the Control Header ISA Segment must be the actual date the transmission is sent.

14. Date Received. For medical bill processing purposes, the Date Received is the date the payer or its agent received the complete medical bill transaction. The Date Received is used to track timely processing of electronic bills, electronic reconsideration/appeal transactions, acknowledgment transactions, and timeliness of payments.

15. Paid Date. When the 005010X221A1 transaction set is used to electronically provide the remittance advice, the Paid Date is the date contained in BPR 16, “Check Issue or EFT Effective Date,” in the Financial Information segment.

16. Description of Code Sets. Code sets utilized in electronic billing and reimbursement and other ancillary

processes are prescribed by the applicable ASC X12 Type 3 Technical Reports (Implementation Guides), NCPDP Implementation Guide, Louisiana Workforce Commission, Office of Workers' Compensation rule, and this companion guide. The code sets are maintained by multiple standard setting organizations. Participants are required to utilize current valid codes based on requirements contained in the applicable implementation guide. The validity of the various codes may be based on the date of service (e.g., procedure and diagnosis codes) or based on the date of the electronic transaction (e.g., claim adjustment reason codes).

17. Participant Roles. Roles in the HIPAA implementation guides are generally the same as in workers' compensation. The Employer, Insured, Injured Employee, and Patient are roles that are used differently in workers' compensation and are addressed later in this section.

a. Trading Partner. Trading Partners are entities that have established EDI relationships and that exchange information electronically either in standard or mutually agreed-upon formats. Trading Partners can be both Senders and Receivers, depending on the electronic process involved (i.e. Billing or Acknowledgment).

b. Sender. A Sender is the entity submitting a transmission to the Receiver, or its Trading Partner. The health care provider, health care facility, or third-party biller/assignee, is the Sender in the 005010X222A1, 005010X223A2 and 005010X224A2 electronic billing transactions. The payer, or its agent, is the Sender in the 005010X214, 005010X231 or 005010X221A1 electronic acknowledgment or remittance transactions.

c. Receiver. A Receiver is the entity that accepts a transmission submitted by a Sender. The health care provider, health care facility, or third-party biller/assignee, is the Receiver in the 005010X214, 005010X231 or 005010X221A1 electronic acknowledgment or remittance transactions. The payer, or its agent, is the Receiver in the 005010X222A1, 005010X223A2, and 005010X224A2 electronic billing transactions.

d. Employer. The Employer, as the policyholder of the workers' compensation insurance coverage or covered through self-insurance, is considered the Subscriber in the workers' compensation implementation of the HIPAA electronic billing and reimbursement formats.

e. Subscriber. The subscriber or insured is the individual or entity that purchases or is covered by an insurance policy or covered through self-insurance. In this implementation, the workers' compensation insurance policy or self-insurance contract is obtained by the Employer, who is considered the Subscriber.

f. Insured. The insured or subscriber is the individual or entity that purchases or is covered by an insurance policy or self-insurance contract. In group health, the insured may be the patient, the spouse or the parent of the patient. In this workers' compensation implementation, the Employer is considered the insured entity.

g. Injured Employee. In workers' compensation, the Injured Employee, as the person who has been injured on the job or has a work related illness, is always considered to be the patient. Thus, the relationship between the insured and the patient is always an employer/employee relationship, as opposed to group health, where there are many possible relationships a patient may have to the insured. For example,

in a group health setting, the patient may be the insured, or may be the child or spouse of the insured, but the child or spouse of the injured employee will never be a covered patient in workers' compensation.

h. Patient. The patient is the person receiving medical services. In the workers' compensation implementation of electronic billing and reimbursement processes, the patient is considered the Injured Employee.

18. Health Care Provider Agent/Payer Agent Roles. Electronic billing and reimbursement rules include provisions that allow for providers and payers to utilize agents to comply with the electronic billing (eBill) requirements. Billing agents, third party administrators, bill review companies, software vendors, data collection agents, and clearinghouses are examples of companies that may have a role in eBill. Payers and health care providers are responsible for the acts or omissions of their agents executed in the performance of services for the payer or health care provider. Under the eBill rules, carriers must be able to receive medical billing from health care providers. Payers may establish direct electronic connections to health care providers or may use agents to perform eBill functions. The rules do not mandate the use of, or regulate the costs of, agents performing eBill functions. Providers and payers are not required by Louisiana Workforce Commission, Office of Workers' Compensation rule to establish connectivity with a clearinghouse or to utilize a specific media/method of connectivity (i.e. Secured File Transfer Protocol [SFTP]). By mutual agreement, use of non-standard formats between the health care provider, health care facility, or third-party biller/assignee and the payer is permissible. The eBill rules do not regulate the formats utilized between providers and their agents, or payers and their agents, or the method of connectivity between those parties.

19. Duplicate, Appeal/Reconsideration, and Corrected Bill Resubmissions

a. Claim Resubmission Code-837 Billing Formats. Health care providers will identify resubmissions of prior medical bills (not including duplicate original submissions) by using the Claim Frequency Type Code of 7 (Resubmission/Replacement). The value is populated in Loop 2300 Claim Information CLM Health Claim Segment CLM05-3 Claim Frequency Type Code of the 005010X222A1, 005010X223A2 and 005010X224A2 electronic billing transactions. When the payer has provided the Payer Claim Control Number it had assigned to the bill being replaced, the health care provider must also use this number in its response to the previous bill submission. This information is populated in Loop 2300 Claim Information REF Payer Claim Control Number of the 005010X222A1, 005010X223A2 and 005010X224A2 electronic billing transactions.

i. On electronically submitted medical bills, health care providers must also populate the appropriate NUBC Condition Code to identify the type of resubmission. Condition codes provide additional information to the payer when the resubmitted bill is a request for reconsideration or a new submission after receipt of a decision from the Louisiana Workforce Commission, Office of Workers' Compensation or other administrative proceeding, such as a judicial review. Based on the instructions for each bill type, the Condition Code is submitted in the HI Segment for

005010X222A1 and 005010X223A2 transactions and in the NTE Segment for the 005010X224A2 transaction. (The use of the NTE segment is at the discretion of the sender.)

ii. The Reconsideration Claim Frequency Type Code '7' is used in conjunction with the Payer Claim Control Number that the claim administrator had assigned to the bill in response to the previous bill submission. This information is populated in Loop 2300 Claim Information REF Payer Claim Control Number of the 005010X222A1, 005010X223A2, and 005010X224A2 electronic billing transactions. The NUBC Instruction for the use of Claim Frequency Type Codes can be referenced on the NUBC website at http://www.nubc.org/FL4forWeb2_RO.pdf. The CMS-required bill processing documentation for adjustments can be referenced at <http://www.cms.hhs.gov/manuals/downloads/clm104c01.pdf>

b. Duplicate Bill Transaction Prior To Payment

i. A Condition Code 'W2' (Duplicate of the original bill) is required when a provider submits a bill that is a duplicate. The Condition Code is submitted based on the instructions for each bill type. It is submitted in the HI segment for professional and institutional transactions and in the NTE segment for dental transactions. (The use of the NTE segment is at the discretion of the sender.) The duplicate bill must be identical to the original bill, with the exception of the added Condition Code. No new dates of service or itemized services may be included on the duplicate bill.

Duplicate Bill Transaction
<ul style="list-style-type: none"> • CLM05-3 = Identical value as original. Cannot be '7'. • Condition codes in HI/K3 are populated with a condition code qualifier 'BG' and code value: 'W2' = Duplicate. • NTE Example: NTE*ADD*BGW2 • Payer Claim Control Number does not apply. • The resubmitted bill must be identical to the original bill, except for the 'W2' condition code. No new dates of service or itemized services may be included on the duplicate bill.

ii. A health care Duplicate bill transaction shall be submitted no earlier than thirty (30) calendar days after the payer has acknowledged receipt of a complete electronic bill transaction or prior to receipt of a 005010X221A1 transaction.

iii. The payer may reject a bill transaction with a Condition Code W2 indicator if

- (a) the duplicate bill is received within thirty (30) calendar days after acknowledgment;
- (b) the bill has been processed and the 005010X221A1 transaction has been generated; or
- (c) the payer does not have a corresponding accepted original transaction with the same bill identification numbers.

iv. If the payer does not reject the duplicate bill transaction within two business days, the duplicate bill transaction may be denied for the reasons listed above through the use of the 005010X221A1 transaction or through a non-electronic EOR process.

c. Corrected Bill Transactions

i. A replacement bill is sent when a data element on the original bill was either not previously sent or needs to be corrected.

ii. When identifying elements change, the correction is accomplished by a void and re-submission process: a bill with CLM05-3 = '8' (Void) must be submitted to cancel the incorrect bill, followed by the submission of a new original bill with the correct information.

iii. Billers should not replace or void a prior bill until that prior submitted bill has reached final adjudication status, which can be determined from the remittance advice, a web application, when showing a finalized code under Claim Status Category 277, or by non-electronic means.

Corrected Bill Transaction
<ul style="list-style-type: none"> • CLM05-3 = '7' indicates a replacement bill. • Condition codes of 'W2' to 'W5' in HI/K3 are not used. • REF*F8 includes the Payer Claim Control Number, if assigned by the payer. • A corrected bill shall include the original dates of service and the same itemized services rendered as the original bill. • When identifying elements change, the correction is accomplished by a void and re-submission process. A bill with CLM05-3 = '8' (Void) must be submitted to cancel the incorrect bill, followed by the submission of a new original bill with the correct information.

iv. The payer may reject a revised bill transaction if

- (a) the payer does not have a corresponding adjudicated bill transaction with the same bill identification number; or
- (b) there is incorrect billing documentation for an adjustment based on CMS guidelines (inappropriate changed data).

v. If the payer does not reject the revised bill transaction within two business days, the revised bill transaction may be denied for the reasons listed above through the use of the 005010X221A1 transaction or through a non-electronic EOR process.

d. Appeal/Reconsideration Bill Transactions. Appeal/reconsideration of disputed disbursements and denials are outlined and detailed in LAC 40 Chapter 51: §5149 and R.S. 23:1034.2(F). Additional information can also be found on the Louisiana Workforce Commission, Office of Workers' Compensation website, www.laworks.net/WorkersComp/OWC_MainMenu.asp.

20. Balance Forward Billing. Balance forward bills are bills that are either for a balance carried over from a previous bill or are for a balance carried over from a previous bill along with charges for additional services. Balance forward billing is not permissible.

21. Louisiana Workforce Commission, Office of Workers' Compensation and Workers' Compensation Specific Requirements. The requirements in this section identify Louisiana Workforce Commission, Office of Workers' Compensation workers' compensation specific requirements that apply to more than one electronic format. Requirements that are related to a specific format are identified in the chapter related to that format.

a. Claim Filing Indicator. The Claim Filing Indicator code for workers' compensation is 'WC' populated in Loop 2000B Subscriber Information, SBR Subscriber Information Segment field SBR09 for the 005010X222A1, 005010X223A2, or 005010X224A2 transactions.

b. Transaction Set Purpose Code. The Transaction Set Purpose Code in the Transaction Set Header BHT Beginning of Hierarchical Transaction Segment field BHT02

in 005010X222A1, 005010X223A2, or 005010X224A2 transactions is designated as '00' Original. Payers are required to acknowledge acceptance or rejection of transmissions (files) and transactions (bills). Transmissions that are rejected by the payer and then corrected by the provider are submitted, after correction, as '00' Original transmissions.

c. Transaction Type Code. The Transaction Type Code in the Transaction Set Header BHT Beginning of Hierarchical Transaction Segment field BHT06 in 005010X222A1, 005010X223A2, or 005010X224A2 transactions is designated as 'CH' Chargeable. Currently, health care providers are not required to report electronic billing data to the Louisiana Workforce Commission, Office

of Workers' Compensation. Therefore, code 'RP' (Reporting) is not appropriate for this implementation.

d. Louisiana Workers' Compensation Specific Requirements that Relate to Multiple Electronic. The requirements in this section identify Louisiana workers' compensation specific requirements that apply to more than one electronic format. Requirements that are related to a specific format are identified in the chapter related to that format.

e. NCPDP Telecommunication Standard D.0 Pharmacy Formats. Issues related to electronic pharmacy billing transactions are addressed in Chapter 6 Companion Guide NCPDP D.0 Pharmacy.

Loop	Segment	Description	Louisiana Companion Guide Workers' Compensation Comments or Instructions
1000A	PER	Submitter EDI Contact Information	Communication Number Qualifier must be 'TE' – Telephone Number
2000B	SBR	Subscriber Information	In workers' compensation, the Subscriber is the Employer.
2000B	SBR04	Name	In workers' compensation, the group name is the employer of the patient/employee.
2000B	SBR09	Claim Filing Indicator Code	Value must be 'WC' for workers' compensation.
2010BA		Subscriber Name	In workers' compensation, the Subscriber is the Employer.
2010BA	NM102	Entity Type Qualifier	Value must be '2' non-person.
2010BA	NM103	Name Last or Organization Name	Value must be the name of the Employer.
2010BA	REF	Property and Casualty Claim Number	Enter the claim number if known, If not known, then enter the default value of "unknown".
2000C	PAT01	Individual Relationship Code	Value must be '20' Employee.
2010CA	REF	Property and Casualty Claim Number	Enter the claim number if known. If not known, then enter the default value of "unknown".
2010CA	REF	Property and Casualty Patient Identifier	Required.
2010CA	REF01	Reference Identification Qualifier	Value must be 'SY'. (Social Security Number)
2010CA	REF02	Reference Identification	Value must be the patient's Social Security Number. When applicable, utilize '999999999' as a default value where the social security number is not known.
2300	CLM11	Related Causes Information	One of the occurrences in CLM11 must have a value of 'EM' -- Employment Related.
2300	DTP	Date -- Accident	Required when the condition reported is for an occupational accident/injury.
2300	DTP	Date -- Disability Dates	Do not use Segment. Leave blank.
2300	DTP	Date -- Property And Casualty Date Of First Contact	Do not use Segment . Not Applicable to LA regulations
2300	PWK	Claim Supplemental Information	Refer to the companion guide for instruction regarding Documentation/Medical Attachment Requirements.
2300	PWK01	Report Type Code	Use appropriate 005010 Report Type Code.
2300	PWK06	Attachment Control Number	Enter the Attachment Control Number Example PWK*OB*BM***AC*DMN0012~
2300	K3	File Information	State Jurisdictional Code is expected here.
2300	K301	Fixed Format Information	Jurisdiction State Code (State of Compliance Code) Required when the provider knows the state of Jurisdiction is different than the billing provider's state (2010AA/N4/N402). Enter the state code qualifier 'LU' followed by the state code. For example, 'LULA' indicates the medical bill is being submitted under Louisiana medical billing requirements.

Loop	Segment	Description	Louisiana Companion Guide Workers' Compensation Comments or Instructions
2300	HI	Condition Information	For workers' compensation purposes, the National Uniform Billing Committee and the National Uniform Claims Committee has approved the following condition code (W2) for resubmission of a duplicate of the original bill. <ul style="list-style-type: none"> W2 - Duplicate of the original bill Note: Do not use condition codes when submitting revised or corrected bills.

C. Companion Guide ASC X12N/005010X222A1 Health Care Claim: Professional (837)

1. Introduction and Overview. The information contained in this companion guide has been created for use in conjunction with the *ASC X12N/005010X222A1 Health Care Claim: Professional (837) Technical Report Type 3*. It is not to be considered a replacement for the *ASC X12N/005010X222A1 Health Care Claim: Professional (837) Technical Report Type 3*, but rather is to be used as an additional source of information. This companion guide is not, nor was it ever intended to be, a comprehensive guide to the electronic transaction requirements for each of the Jurisdictions. The companion guide is intended to be used by Jurisdictions to develop and publish companion guides tailored to their regulatory environment that consistently apply the syntactical requirements of the *ASC X12 Type 3 Technical Reports*. The *ASC X12N/005010X222A1 Health Care Claim: Professional (837) Technical Report Type 3* is available through the Accredited Standards Committee (ASC) X12, <http://store.x12.org>.

2. Purpose, Applicability, and Expected Implementation Date. The purpose of Electronic Billing (LAC40:ICchapter 3) is to provide a framework for electronic

billing, processing, and payment of medical services and products provided to an injured employee and data reporting subject to R.S. 23:1203.2, mandated for insurance carriers, beginning July 1, 2013 for electronic submissions.

3. Trading Partner Agreements. The components of trading partner agreements that define other transaction parameters beyond the ones described in this companion guide (such as transmission parameters) remain the same; this companion guide is not intended to replace any of those components. The data elements transmitted as part of a Trading Partner Agreement must, at a minimum, contain all the same required data elements found within the *ASC X12 Type 3 Technical Reports* and the Jurisdiction-specific companion guide. The Trading Partner Agreement must not change the workers' compensation field value designations as defined in the Jurisdiction-specific companion guide.

4. Workers' Compensation Health Care Claim: Professional Instructions. Instructions for Louisiana specific requirements are also provided in Louisiana Workers' Compensation Requirements. The following table identifies the application/ instructions for Louisiana workers' compensation that need clarification beyond the *ASC X12 Type 3 Technical Reports*.

ASC X12N/005010X222A1			
Loop	Segment	Description	Louisiana Companion Guide Workers' Compensation Comments or Instructions
1000A	PER	Submitter EDI Contact Information	Communication Number Qualifier must be 'TE' – Telephone Number
2000B	SBR	Subscriber Information	In workers' compensation, the Subscriber is the Employer.
2000B	SBR04	Name	In workers' compensation, the group name is the employer of the patient/employee.
2000B	SBR09	Claim Filing Indicator Code	Value must be 'WC' for workers' compensation.
2010BA		Subscriber Name	In workers' compensation, the Subscriber is the Employer.
2010BA	NM102	Entity Type Qualifier	Value must be '2' non-person.
2010BA	NM103	Name Last or Organization Name	Value must be the name of the Employer.
2010BA	REF	Property And Casualty Claim Number	Enter the claim number if known, If not known, then enter the default value of "unknown".
2000C	PAT01	Individual Relationship Code	Value must be '20' Employee.
2010CA	REF	Property and Casualty Claim Number	Enter the claim number if known. If not known, then enter the default value of "unknown".
2010CA	REF	Property and Casualty Patient Identifier	Required.
2010CA	REF01	Reference Identification Qualifier	Value must be 'SY'. (Social Security Number)
2010CA	REF02	Reference Identification	Value must be the patient's Social Security Number. When applicable, utilize '999999999' as a default value where the social security number is not known.
2300	CLM11	Related Causes Information	One of the occurrences in CLM11 must have a value of 'EM' -- Employment Related.
2300	DTP	Date -- Accident	Required when the condition reported is for an occupational accident/injury.

ASC X12N/005010X222A1			
Loop	Segment	Description	Louisiana Companion Guide Workers' Compensation Comments or Instructions
2300	DTP	Date – Disability Dates	Do not use Segment. Leave blank.
2300	DTP	Date – Property And Casualty Date Of First Contact	Do not use Segment . Not Applicable to LA regulations
2300	PWK	Claim Supplemental Information	Refer to the companion guide for instruction regarding Documentation/Medical Attachment Requirements.
2300	PWK01	Report Type Code	Use appropriate 005010 Report Type Code.
2300	PWK06	Attachment Control Number	Enter the Attachment Control Number Example PWK*OB*BM***AC*DMN0012~
2300	K3	File Information	State Jurisdictional Code is expected here.
2300	K301	2300	Jurisdiction State Code (State of Compliance Code) Required when the provider knows the state of Jurisdiction is different than the billing provider's state (2010AA/N4/N402). Enter the state code qualifier 'LU' followed by the state code. For example, 'LULA' indicates the medical bill is being submitted under Louisiana medical billing requirements.
	HI	Condition Information	For workers' compensation purposes, the National Uniform Billing Committee and the National Uniform Claims Committee has approved the following condition code (W2) for resubmission of a duplicate of the original bill. <ul style="list-style-type: none"> W2 - Duplicate of the original bill Note: Do not use condition codes when submitting revised or corrected bills.

D. Companion Guide ASC X12N/005010X223A2 Health Care Claim: Institutional (837)

1. Introduction and Overview. The information contained in this companion guide has been created for use in conjunction with the *ASC X12N/005010X223A2 Health Care Claim: Institutional (837) Technical Report Type 3*. It is not a replacement for the *ASC X12N/005010X223A2 Health Care Claim: Institutional (837) Technical Report Type 3*, but rather is an additional source of information. This companion guide is not, nor was it ever intended to be, a comprehensive guide to the electronic transaction requirements for each of the Jurisdictions. The companion guide is intended to be used by Jurisdictions to develop and publish companion guides tailored to their regulatory environment that consistently apply the syntactical requirements of the *ASC X12 Type 3 Technical Reports*. The *ASC X12N/005010X223A2 Health Care Claim: Institutional (837) Technical Report Type 3* is available through the Accredited Standards Committee (ASC) X12, <http://store.x12.org>.

2. Purpose, Applicability and Expected Implementation Date. The purpose of Electronic Billing (LAC40:ICchapter 3) is to provide a framework for electronic billing, processing, and payment of medical services and

products provided to an injured employee and data reporting subject to R.S. 23:1203.2, mandated for insurance carriers, beginning July 1, 2013 for electronic submissions.

3. Trading Partner Agreements. The components of trading partner agreements that define other transaction parameters beyond the ones described in this companion guide (such as transmission parameters) remain the same; this companion guide is not intended to replace any of those components. The data elements transmitted as part of a Trading Partner Agreement must, at a minimum, contain all the same required data elements found within the *ASC X12 Type 3 Technical Reports* and the Jurisdiction-specific companion guide. The workers' compensation field value designations as defined in the Jurisdiction-specific companion guide must remain the same as part of any Trading Partner Agreement.

4. Workers' Compensation Health Care Claim: Institutional Instructions. Instructions for Louisiana specific requirements are also provided in Louisiana Workers' Compensation Requirements. The following table identifies the application/instructions for Louisiana workers' compensation that need clarification beyond the *ASC X12 Type 3 Technical Reports*:

ASC X12N/005010X223A2			
Loop	Segment	Description	Louisiana Companion Guide Workers' Compensation Comments or Instructions
1000A	PER	Submitter EDI Contact Information	Communication Number Qualifier must be 'TE' – Telephone Number
2000B	SBR	Subscriber Information	In workers' compensation, the Subscriber is the Employer.
2000B	SBR04	Name	In workers' compensation, the group name is the employer of the patient/employee.
2000B	SBR09	Claim Filing Indicator Code	Value must be 'WC' for workers' compensation.
2010BA		Subscriber Name	In workers' compensation, the Subscriber is the Employer.

ASC X12N/005010X223A2			
Loop	Segment	Description	Louisiana Companion Guide Workers' Compensation Comments or Instructions
2010BA	NM102	Entity Type Qualifier	Value must be '2' non-person.
2010BA	NM103	Name Last or Organization Name	Value must be the name of the Employer.
2010BA	REF	Property and Casualty Claim Number	Enter the claim number if known. If not known, then enter the default value of "unknown".
2000C	PAT01	Individual Relationship Code	Value must be '20' Employee.
2010CA	REF02	Property Casualty Claim Number	Enter the claim number if known. If not known, then enter the default value of "unknown".
2010CA	REF	Property and Casualty Patient Identifier	Required.
2010CA	REF01	Reference Identification Qualifier	Value must be 'SY'. (Social Security Number)
2010CA	REF02	Reference Identification	Value must be the patient's Social Security Number.
2300	PWK	Claim Supplemental Information	Refer to the Jurisdiction companion guide for instruction regarding Documentation/Medical Attachment Requirements.
2300	PWK01	Report Type Code	Use appropriate 005010 Report Type Code.
2300	PWK06	Attachment Control Number	Enter the Attachment Control Number Example: PWK*OB*BM***AC*DMN0012~
2300	K3	File Information	State Jurisdictional Code is expected here.
2300	K301	Fixed Format Information	Required when the provider knows the state of Jurisdiction is different than the billing provider's state (2010AA/N4/N402). Enter the state code qualifier 'LU' followed by the state code. For example, 'LULA' indicates the medical bill is being submitted under Louisiana medical billing requirements.
2300	HI01	Occurrence Information	At least one Occurrence Code must be entered with value of '04' - Accident/Employment Related or '11' -- illness. The Occurrence Date must be the Date of Occupational Injury or Illness.
2300	HI	Condition Information	For workers' compensation purposes, the National Uniform Billing Committee and the National Uniform Claims Committee has approved the following condition code (W2) for resubmissions of a duplicate of the original bill. <ul style="list-style-type: none"> W2 - Duplicate of the original bill Note: Do not use condition codes when submitting revised or corrected bills.

E. Companion Guide ASC X12N/005010X224A2 Health Care Claim: Dental (837)

1. Introduction and Overview. The information contained in this companion guide has been created for use in conjunction with the *ASC X12N/05010X224A2 Health Care Claim: Dental (837) Technical Report Type 3*. It is not a replacement for the *ASC X12N/05010X224A2 Health Care Claim: Dental (837) Technical Report Type 3*, but rather is an additional source of information. This companion guide is not, nor was it ever intended to be, a comprehensive guide to the electronic transaction requirements for each of the Jurisdictions. The companion guide is intended to be used by Jurisdictions to develop and publish companion guides tailored to their regulatory environment that consistently apply the syntactical requirements of the *ASC X12 Type 3 Technical Reports*. The *ASC X12N/05010X224A2 Health Care Claim: Dental (837) Technical Report Type 3* is available through the Accredited Standards Committee (ASC) X12, <http://store.x12.org>.

2. Purpose, Applicability and Expected Implementation Date. The purpose of Electronic Billing (LAC40:ICchapter 3) is to provide a framework for electronic billing, processing, and payment of medical services and

products provided to an injured employee and data reporting subject to R.S. 23:1203.2, mandated for insurance carriers, beginning July 1, 2013 for electronic submissions.

3. Trading Partner Agreements. The components of trading partner agreements that define other transaction parameters beyond the ones described in this companion guide (such as transmission parameters) remain the same; this companion guide is not intended to replace any of those components. The data elements transmitted as part of a Trading Partner Agreement must, at a minimum, contain all the same required data elements found within the *ASC X12 Type 3 Technical Reports* and the Jurisdiction-specific companion guide. The workers' compensation field value designations as defined in the Jurisdiction-specific companion guide must remain the same as part of any Trading Partner Agreement.

4. Workers' Compensation Health Care Claim: Dental Instructions. Instructions for Louisiana specific requirements are also provided in Louisiana Workers' Compensation Requirements. The following table identifies the application/instructions for Louisiana workers' compensation that need clarification beyond the *ASC X12 Type 3 Technical Reports*.

Loop	Segment	Description	Louisiana Companion Guide Workers' Compensation Comments or Instructions
1000A	PER	Submitter EDI Contact Information	Communication Number Qualifier must be 'TE' – Telephone Number
2000B	SBR	Subscriber Information	In workers' compensation, the Subscriber is the Employer.
2000B	SBR04	Name	In workers' compensation, the group name is the employer of the patient/employee.
2000B	SBR09	Claim Filing Indicator Code	Value must be 'WC' for workers' compensation.
2010BA		Subscriber Name	In workers' compensation, the Subscriber is the Employer.
2010BA	NM102	Entity Type Qualifier	Value must be '2' non-person.
2010BA	NM103	Name Last Or Organization Name	Value must be the name of the Employer.
2010BA	REF	Property And Casualty Claim Number	Enter the claim number if known. If not known, then enter the default value of "unknown".
2000C	PAT01	Individual Relationship Code	Value must be '20' Employee.
2010CA	REF02	Property Casualty Claim Number	Enter the claim number if known. If not known, then enter the default value of "unknown".
2300	CLM11	Related Causes Information	One of the occurrences in CLM11 must have a value of 'EM' -- Employment Related.
2010CA	REF	Property And Casualty Patient Identifier	Required.
2010CA	REF01	Reference Identification Qualifier	Value must be 'SY'. (Social Security Number)
2010CA	REF02	Reference Identification	Value must be the patient's Social Security Number.
2300	DTP	Date – Accident	Required when the condition reported is for an occupational accident/injury.
2300	PWK	Claim Supplemental Information	Refer to the Jurisdiction companion guide for instruction regarding Documentation/Medical Attachment Requirements.
2300	PWK01	Report Type Code	Use appropriate 005010 Report Type Code.
2300	PWK06	Attachment Control Number	Enter Attachment Control Number Example: PWK*OB*BM***AC*DMN0012~
2300	K3	File Information	State Jurisdictional Code is expected here.
2300	K301	Fixed Format Information	Jurisdiction State Code (State of Compliance Code) Required when the provider knows the state of Jurisdiction is different than the billing provider's state (2010AA/N4/N402). Enter the state code qualifier 'LU' followed by the state code. For example, 'LULA' indicates the medical bill is being submitted under Louisiana medical billing requirements.

F. Companion Guide NCPDP D.0 Pharmacy

1. Introduction and Overview. The information contained in this companion guide has been created for use in conjunction with the *NCPDP Telecommunication Standard Implementation Guide Version D.0* for pharmacy claim transactions. It is not a replacement for the *NCPDP Telecommunication Standard Implementation Guide Version D.0*, but rather is an additional source of information. Pharmacy transactions are processed both in real-time and via batch. Every transmission request has a transmission response. To address the appropriate process for responding to request transactions and reversal processing, users are

directed to utilize the *NCPDP Telecommunication Standard Implementation Guide Version D.0* and *Batch Standard Implementation Guide Version 1.2*. This companion guide is not, nor was it ever intended to be, a comprehensive guide to the electronic transaction requirements for each of the Jurisdictions. The companion guide is intended to be used by Jurisdictions to develop and publish companion guides tailored to their regulatory environment that consistently apply the syntactical requirements of the *NCPDP Implementation Guide*. The implementation guide for electronic pharmacy claims and responses is available

through the National Council for Prescription Drug Programs (NCPDP) at <http://www.ncdp.org>.

2. Purpose, Applicability and Expected Implementation Date. The purpose of Electronic Billing (LAC40:ICchapter 3) is to provide a framework for electronic billing, processing, and payment of medical services and products provided to an injured employee and data reporting subject to R.S. 23:1203.2, mandated for insurance carriers, beginning July 1, 2013 for electronic submissions.

3. Trading Partner Agreements. The components of trading partner agreements that define other transaction parameters beyond the ones described in this companion guide (such as transmission parameters) remain the same; this companion guide is not intended to replace any of those components. The data elements transmitted as part of a Trading Partner Agreement must, at a minimum, contain all the same required data elements found within the NCPDP

Implementation Guide and the Jurisdiction-specific companion guide. The workers' compensation field value designations as defined in the Jurisdiction-specific companion guide must remain the same as part of any Trading Partner Agreement. Where a payer has a separate contract with a Pharmacy Benefits Manager (PBM), the data elements exchanged between the payer and PBM may be in a mutually agreed upon format.

4. Workers' Compensation NCPDP Pharmacy Claim Instructions. Instructions for Louisiana specific requirements are also provided in Louisiana Workers' Compensation Requirements. The following table identifies the application/instructions for Louisiana workers' compensation that need clarification beyond the *NCPDP Telecommunication Standard Implementation Guide Version D.0*.

Segment	Field	Description	Louisiana Companion Guide Workers' Compensation Comments or Instructions
Insurance	302-C2	Cardholder ID	If the Cardholder ID is not available or not applicable, the value must be 'NA'."
Claim	415-DF	Number of Refills Authorized	This data element is optional.
Pricing	426-DQ	Usual and Customary Charge	This data element is optional.
Pharmacy Provider	465-EY	Provider ID Qualifier	This data element is required. The value must be '05' – NPI Number.
Prescriber	466-EZ	Prescriber ID Qualifier	This data element is required. The value must be '01' – NPI Number, however, if prescriber NPI is not available, enter applicable prescriber ID qualifier.
Workers' Compensation			The Workers' Compensation Segment is required for workers' compensation claims
Workers' Compensation	435-DZ	Claim/Reference ID	Enter the claim number if known. If not known, then enter the default value of "unknown".
Clinical			This data element is optional.
Additional Documentation			The Additional Documentation segment can be utilized for any additional information that does not have a required field above.

G. Companion Guide ASC X12N/005010X221A1 Health Care Claim Payment/Advice (835)

1. Introduction and Overview. The information contained in this companion guide has been created for use in conjunction with the *ASC X12N/005010X221A1 Health Care Claim Payment Advice (835) Technical Report Type 3*. It is not a replacement for the *ASC X12N/005010X221A1 Health Care Claim Payment Advice (835) Technical Report Type 3*, but rather is an additional source of information. This companion guide is not, nor was it ever intended to be, a comprehensive guide to the electronic transaction requirements for each of the Jurisdictions. The companion guide is intended to be used by Jurisdictions to develop and publish companion guides tailored to their regulatory environment that consistently apply the syntactical

requirements of the *ASC X12 Type 3 Technical Reports*. The *ASC X12N/005010X221A1 Health Care Claim Payment Advice (835) Technical Report Type 3* is available through the Accredited Standards Committee (ASC) X12, <http://store.x12.org>. The *NCPDP ASC X12N 835 (005010X221) Pharmacy Remittance Advice Template*, is available at http://www.ncdp.org/public_documents.asp.

2. Purpose, Applicability and Expected Implementation Date. The purpose of Electronic Billing (LAC40:ICchapter 3) is to provide a framework for electronic billing, processing, and payment of medical services and products provided to an injured employee and data reporting subject to R.S. 23:1203.2, mandated for insurance carriers, beginning July 1, 2013 for electronic submissions.

Electronic remittance notification is not mandated at this time and may be used upon mutual agreement of the parties.

3. Trading Partner Agreements. The components of trading partner agreements that define other transaction parameters beyond the ones described in this companion guide (such as transmission parameters) remain the same; this companion guide is not intended to replace any of those components. The data elements transmitted as part of a Trading Partner Agreement must at a minimum contain all the same required data elements found within the *ASC X12 Type 3 Technical Reports* and the Jurisdiction-specific companion guide. The workers' compensation field value designations as defined in the Jurisdiction-specific companion guide must remain the same as part of any Trading Partner Agreement. Trading Partner Agreements pertaining to Claims Adjustment Group Codes and Claim Adjustment Reason Code/Remittance Advice Remark Code combinations must follow the current ASC X12N Technical Report Type 2 (TR2) Code Value Usage in Health Care Claim Payments and Subsequent Claims Reference Model, that identifies usage standards when providing payment, reduction, or denial information. The TR2 is available at <http://store.x12.org>.

4. Claim Adjustment Group Codes. The 005010X221A1 transaction requires the use of Claim Adjustment Group Codes. The most current valid codes must be used as appropriate for workers' compensation. The Claim Adjustment Group Code represents the general category of payment, reduction, or denial. For example, the Group Code 'CO' (Contractual Obligation) might be used in conjunction with a Claim Adjustment Reason Code for a network contract reduction. The Claim Adjustment Group Code transmitted in the 005010X221A1 transaction is the same code that is transmitted in the IAIABC 837 Medical State Reporting EDI reporting format. Louisiana Workforce Commission, Office of Workers Compensation accepts Claim Adjustment Group Codes that were valid on the date the payer paid or denied a bill.

5. Claim Adjustment Reason Codes. The 005010X221A1 transaction requires the use of Claim Adjustment Reason Codes (CARC) codes as the electronic means of providing specific payment, reduction, or denial information. As a result, use of the 005010X221A1 transaction eliminates the use of proprietary reduction codes, Jurisdiction specific claim adjustment reason codes, and free form text used on paper Explanation of Review (EOR) forms. Claim Adjustment Reason Codes are available through Washington Publishing Company at www.wpc-edi.com/codes. The ASC X12N Technical Report Type 2 (TR2) Code Value Usage in Health Care Claim Payments and Subsequent Claims Reference Model is the encyclopedia of Claim Adjustment Group Codes, Claim Adjustment Reason Code (CARC) and Remittance Advice Remark Code (RARC) combinations. The most current TR2 specified

CARC and/or CARC RARC code combinations are to be used when providing payment, reduction, or denial information. The TR2 is available at <http://store.x12.org>. There is a great amount of variability in the mapping and combinations of codes used in the industry today. This results in different interpretations by the providers for each payer. The TR2 defines CARC/RARC combinations which will provide a concrete and predictable message allowing the providers to set up rules to automate actions based upon the combinations of codes. Consistent use of these codes across all payers will result in significant administrative simplification in the workers' compensation industry. Every three months codes are added, modified or deleted through the ASC X12 External Code Committee process. These changes are maintained by ASC X12 and are updated in the TR2. If it is determined that a code, or CARC/RARC combination, needs to be added, modified or deleted, contact the IAIABC EDI Medical Committee to submit your request at www.IAIABC.org/.

6. Remittance Advice Remark Codes. The 005010X221A1 transaction supports the use of Remittance Advice Remark Codes to provide supplemental explanations for a payment, reduction, or denial already described by a Claim Adjustment Reason Code. NCPDP Reject Codes are allowed for NCPDP transactions. Payers must use the remittance remark codes to provide additional information to the health care provider regarding why a bill was adjusted or denied. The use of the 005010X221A1 transaction eliminates the use of proprietary reduction codes and free form text used on paper Explanation of Review (EOR) forms. Remittance Advice Remark Codes are not associated with a Group or Reason Code in the same manner that a Claim Adjustment Reason Code is associated with a Group Code. Currently, the 005010X221A1 is an optional transaction to be used upon mutual agreement by the payer and healthcare provider. Remittance Advice Remark Codes are available through Washington Publishing Company at <http://www.wpc-edi.com/codes>.

7. Product/Service ID Qualifier. The Product/Service Identification Number transmitted in the inbound electronic billing format is returned in the 005010X221A1 transaction SVC Service Payment Information Segment with the appropriate qualifier.

8. Workers' Compensation Health Care Claim Payment/Advice Instructions. Instructions for Louisiana specific requirements are also provided in Louisiana Workers' Compensation Requirements. The following table identifies the application/instructions for Louisiana workers' compensation requirements that need clarification beyond the *ASC X12 Type 3 Technical Reports*. Currently, the 005010X221A1 is an optional transaction to be used upon mutual agreement by the payer and healthcare provider.

ASC X12N/005010X221A1				
Loop	Segment or Element	Value	Description	Louisiana Companion Guide Workers' Compensation Comments or Instructions
1000A	PER		Payer Technical Contact Information	
	PER03	TE	Communication Number Qualifier	Value must be 'TE' Telephone Number
	PER04		Communication Number	Value must be the Telephone Number of the submitter.
2100	CLP		Claim Level Data	
	CLP06	WC	Claim Filing Indicator Code	Value must be "WC" – Workers' Compensation
	CLP07		Payer Claim Control Number	The payer- assigned claim control number for workers' compensation use is the bill control number.

H. Companion Guide ASC X12N/005010X210 Additional Information to Support a Health Care Claim or Encounter (275)

1. Introduction and Overview. The information contained in this companion guide has been created for use in conjunction with the *ASC X12N/005010X210 Additional Information to Support a Health Care Claim or Encounter (275) Technical Report Type 3*. It is not a replacement for the *ASC X12N/005010X210 Additional Information to Support a Health Care Claim or Encounter (275) Technical Report Type 3*, but rather is an additional source of information. This companion guide is not, nor was it ever intended to be, a comprehensive guide to the electronic transaction requirements for each of the Jurisdictions. The companion guide is intended to be used by Jurisdictions to develop and publish companion guides tailored to their regulatory environment that consistently apply the syntactical requirements of the *ASC X12N Type 3 Technical Reports*. The *ASC X12N/005010X210 Additional Information to Support a Health Care Claim or Encounter (275) Technical Report Type 3* is available through the Accredited Standards Committee (ASC) X12, <http://store.x12.org>.

2. Purpose, Applicability, and Expected Implementation Date. The purpose of Electronic Billing (LAC40:IC chapter 3) is to provide a framework for electronic billing, processing, and payment of medical services and products provided to an injured employee and data reporting subject to R.S. 23:1203.2, mandated for insurance carriers, beginning July 1, 2013 for electronic submissions.

3. Method of Transmission. The 005010X210 transaction is the prescribed standard electronic format for submitting electronic documentation. Health care providers, health care facilities, or third party biller/assignees and payers may agree to exchange documentation in other non-prescribed electronic formats (such as uploading to a web-based system) by mutual agreement. If trading partners mutually agree to use non-prescribed formats for the documentation they exchange, they must include all components required to identify the information associated with the documentation. Health care providers, health care

facilities, or third party biller/assignees and payers may also elect to submit documentation associated with electronic bill transactions through facsimile (fax) or electronic mail (email) in accordance Electronic Billing (LAC40:I. Chapter 3). Health care providers, health care facilities, or third party biller/assignees and payers must be able to electronically exchange medical documentation that is required to be submitted with the bill based on the regulatory requirements found in Electronic Billing (LAC 40.I.Chapter 3).

4. Documentation Requirements. "Medical documentation" includes, but is not limited to, medical reports and records, such as evaluation reports, narrative reports, assessment reports, progress report/notes, clinical notes, hospital records, and diagnostic test results. Documentation requirements for Louisiana workers' compensation billing are defined in Electronic Billing (LAC 40.I.Chapter 3).

I. Companion Guide Acknowledgments

1. There are several different acknowledgments that a clearinghouse and/or payer may use to respond to the receipt of a bill. The purpose of these acknowledgments is to provide feedback on the following:

- Basic file structure and the trading partner information from the Interchange Header.
- Detailed structure and syntax of the actual bill data as specified by the X12 standard.
- The content of the bill against the Jurisdictional complete bill rules.
- Any delays caused by claim number indexing/validation.
- Any delays caused by attachment matching.
- The outcome of the final adjudication, including reassociation to any financial transaction.

2. Bill Acknowledgment Flow and Timing Diagrams. The process chart below illustrates how a receiver validates and processes an incoming 005010X222A1, 005010X223A2, or 005010X224A2 transaction. The diagram shows the basic acknowledgments that the receiver generates, including acknowledgments for validation and final adjudication for those bills that pass validation.

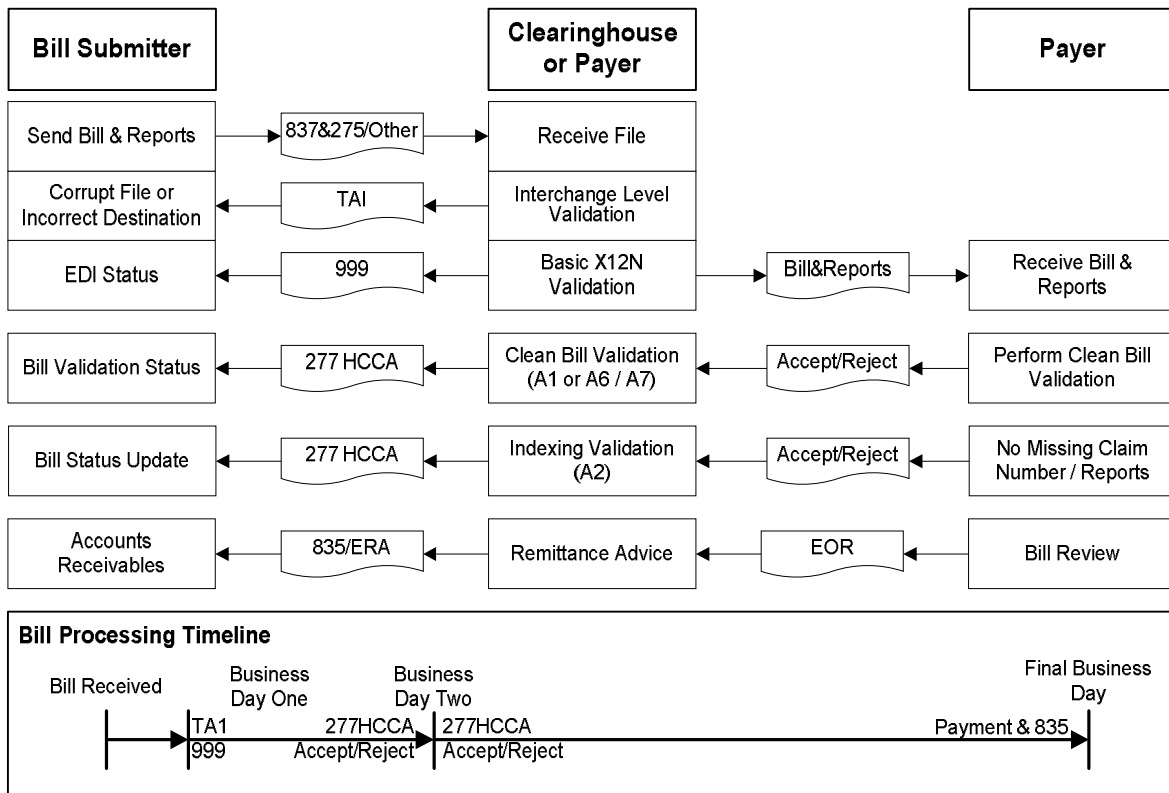

3. Process Steps

a. Interchange Level Validation: Basic file format and the trading partner information from the Interchange Header are validated. If the file is corrupt or is not the expected type, the file is rejected. If the trading partner information is invalid or unknown, the file is rejected. A TA1 (Interchange Acknowledgment) is returned to indicate the outcome of the validation. A rejected EDI file is not passed on to the next step.

b. Basic X12 Validation: A determination will be made as to whether the transaction set contains a valid 005010X222A1. A 005010X231 (Functional Acknowledgment) will be returned to the submitter. The 005010X231 contains ACCEPT or REJECT information. If the file contains syntactical errors, the locations of the errors are reported. Bills that are part of a rejected transaction set are not passed on to the next step.

c. Clean Bill Validation: The jurisdictional and payer specific edits are run against each bill within the transaction set. The receiver returns a 005010X214 (Health Care Claim Acknowledgment) to the submitter to acknowledge that the bill was accepted or rejected. Bills that are rejected are not passed on to the next step.

d. Clean Bill-Missing Claim Number and/or Missing Required Report: Refer to Section 9.2 Clean Claim - Missing Claim Number Pre-Adjudication Hold (Pending) Status and Section 9.3 Clean Claim - Missing Report Pre-Adjudication Hold (Pending) Status regarding bill acknowledgment flow and timeline diagrams.

e. Bill Review: The bills that pass through bill review and any post-bill review approval process will be reported in the 005010X221A1 (Remittance Payment/Advice). The 005010X221A1 contains the

adjudication information from each bill, as well as any paper check or EFT payment information. Currently, the 005010X221A1 is an optional transaction to be used upon mutual agreement by the payer and healthcare provider.

4. Clean Bill-Missing Claim Number Pre-Adjudication Hold (Pending) Status

a. One of the processing steps that a bill goes through prior to adjudication is verification that the bill concerns an actual employment-related condition that has been reported to the employer and subsequently reported to the claims administrator. This process, usually called “claim indexing/validation” can cause a delay in the processing of the bill. Once the validation process is complete, the claim administrator assigns a claim number to the injured worker’s claim. This claim number is necessary for the proper processing of any bills associated with the claim. Until the claim number is provided to the bill submitter, it cannot be included on the 005010X222A1, 005010X223A2, and 005010X224A2 submission to the payer. In order to prevent medical bills from being rejected due to lack of a claim number, a pre-adjudication hold (pending) period of up to five business days is mandated to enable the payer to attempt to match the bill to an existing claim in its system. If the bill cannot be matched within the five business days, the bill may be rejected as incomplete. If the payer is able to match the bill to an existing claim, it must attach the claim number to the transaction and continue the adjudication process. The payer then provides the claim number to the bill submitter using the 005010X214 for use in future billing. The 005010X214 is also used to inform the bill submitter of the delay and the ultimate resolution of the issue. Due to the pre-adjudication hold (pend) status, a payer may send one STC segment with up to three claim status composites (STC01,

STC10, and STC11) in the 005010X214. When a clean claim has a missing claim number and a missing report, the one STC segment in the 005010X214 would have the following three claim status composites: STC01, STC10, and STC11.

i. An example: STC*A1:21*20090830*WQ*70*****A1:629*A1:294~

b. When a clean bill is only missing a claim number or missing a report, the one STC segment in the

005010X214 would have the following two claim status composites: STC01 and STC10.

i. An example: STC*A1:21*20090830*WQ*70*****A1:629~

c. A bill submitter could potentially receive two 005010X214 transactions as a result of the pre-adjudication hold (pend) status.

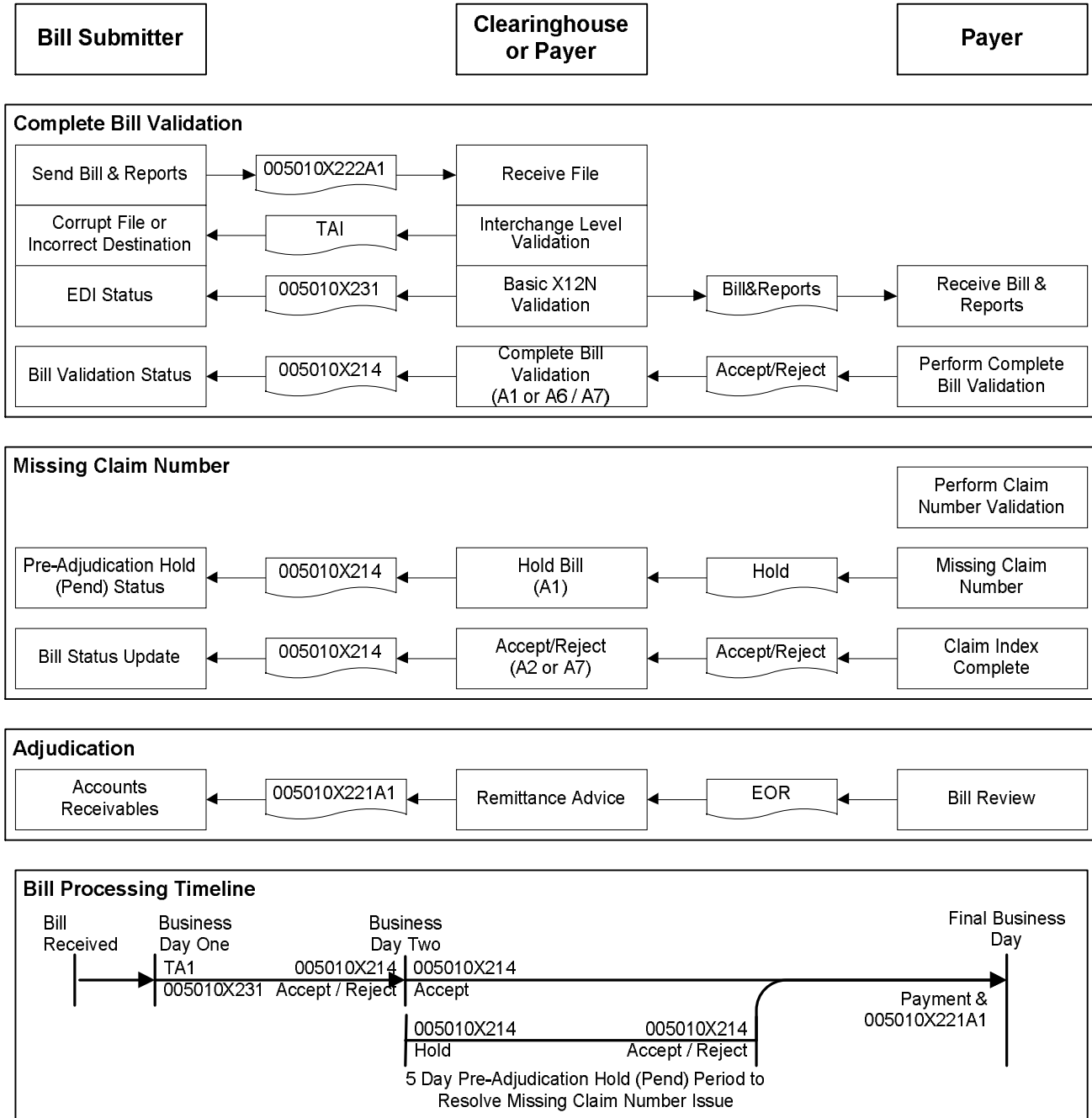

5. Missing Claim Number 005010X214 Acknowledgment Process Steps. When the 005010X222A1, 005010X223A2, or 005010X224A2 transaction has passed the clean bill validation process and Loop 2010 CA REF02 indicates that the workers' compensation claim number is "unknown," the payer will need to respond with the appropriate 005010X214.

Claim Number Validation Status	005010X214
Clean Bill - Missing Claim Number	<p>If the payer needs to pend an otherwise clean bill due to a missing claim number, it must use the following Claim Status Category Code and Claim Status Code:</p> <p>STC01-1 = A1 (The claim/encounter has been received. This does not mean that the claim has been accepted for adjudication.)</p> <p>STC01-2 = 21 (Missing or Invalid Information)</p> <p>AND</p> <p>STC10-1 = A1 (The claim/encounter has been received. This does not mean that the claim has been accepted for adjudication.)</p> <p>STC10-2 = 629 (Property Casualty Claim Number)</p> <p>Example: STC*A1:21*20090830*WQ*70*****A1:629~</p>
Claim Was Found	<p>Once the Claim Indexing/Validation process has been completed and there is a bill/claim number match, then use the following Claim Status Category Code with the appropriate Claim Status Code:</p> <p>STC01-1 = A2 Acknowledgment/Acceptance into adjudication system. The claim/encounter has been accepted into the adjudication system.</p> <p>STC01-2 = 20 Accepted for processing</p> <p>Payer Claim Control Number: Use Loop 2200D REF segment "Payer Claim Control Number with qualifier 1K Identification Number to return the workers' compensation claim number and or the payer bill control number in the REF02:</p> <p>a. Always preface the workers' compensation claim number with the two digit qualifier "Y4" followed by the property casualty claim number. Example: Y412345678</p>

Claim Number Validation Status	005010X214
	<p>b. If there are two numbers (payer claim control number and the workers' compensation claim number) returned in the REF02, then use a blank space to separate the numbers.</p> <p>- The first number will be the payer claim control number assigned by the payer (bill control number).</p> <p>- The second number will be the workers' compensation property and casualty claim number assigned by the payer with a "Y4" qualifier followed by the claim number. -Example: REF*1K*3456832 Y43333445556~</p>
No Claim Found	<p>After the Claim Indexing/ Validation process has been completed and there is no bill/ claim number match, use the following Claim Status Category Code with the appropriate Claim Status Code:</p> <p>STC01-1 = A6 Acknowledgment/Rejected for Missing Information. The claim/encounter is missing the information specified in the Status details and has been rejected.</p> <p>STC01-2 = 629 Property Casualty Claim Number (No Bill/Claim Number Match)</p>

6. Clean Bill - Missing Report Pre-Adjudication Hold (Pending) Status. One of the processing steps that a bill goes through prior to adjudication is verification that all required documentation has been provided. The bill submitter can send the reports using the 005010X210 or other mechanisms such as fax or e-mail. In order to prevent medical bill rejections because required documentation was sent separately from the bill itself, a pre-adjudication hold (pending) period of up to five business days is mandated to enable the payer to receive and match the bill to the documentation. If the bill cannot be matched within the five business days, or if the supporting documentation is not received, the bill may be rejected as incomplete. If the payer is able to match the bill to the documentation within the five business day hold period, it continues the adjudication process. The 005010X213 is used to inform the bill submitter of the delay and the ultimate resolution of the issue.

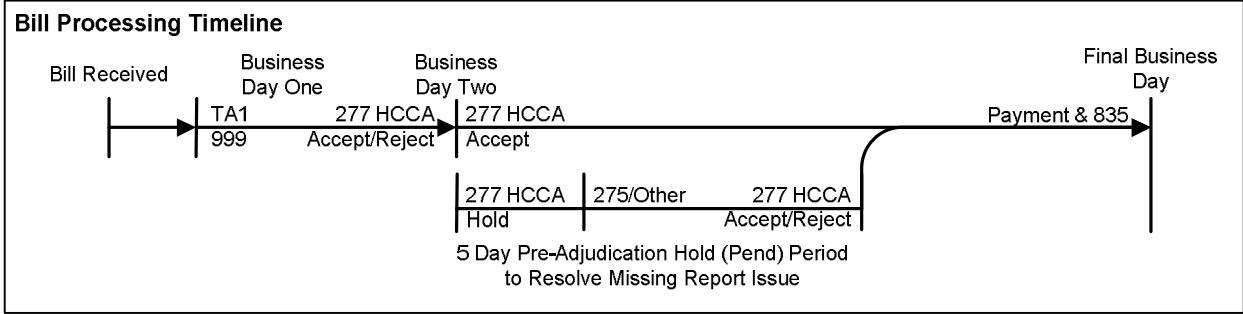
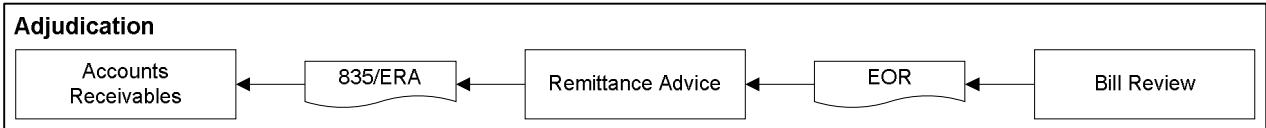
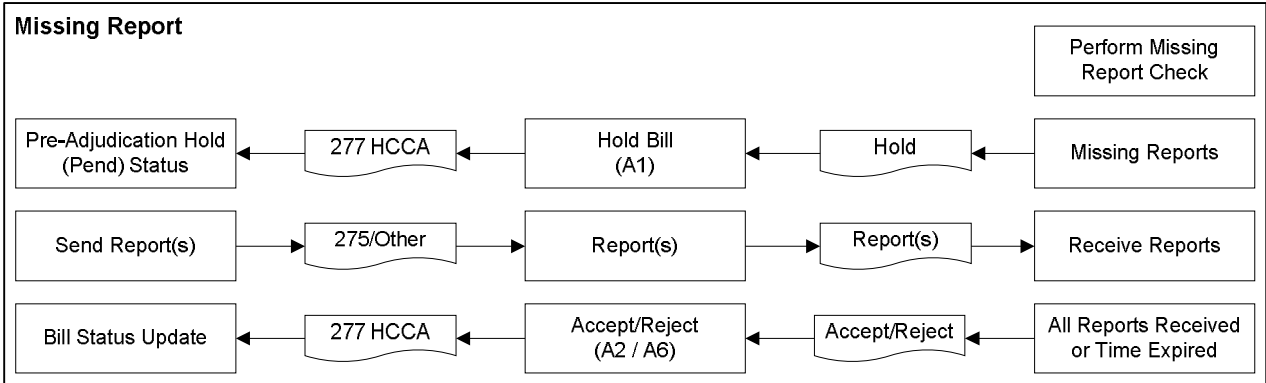
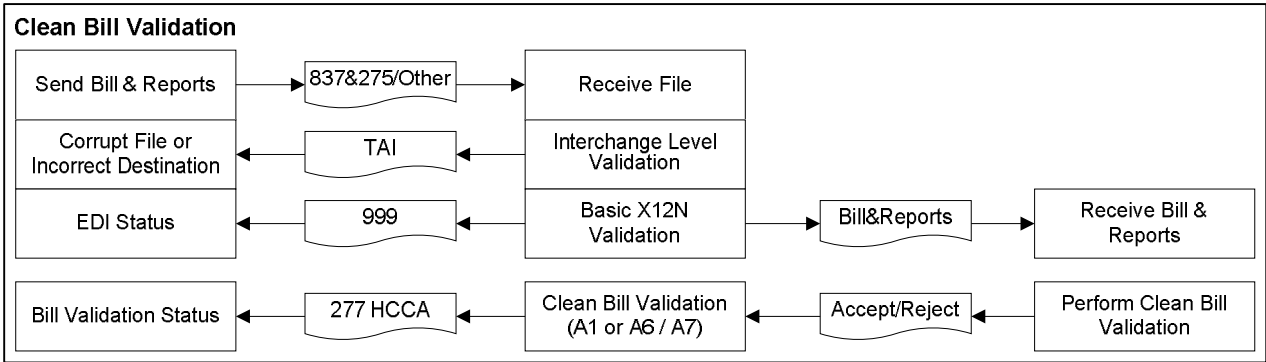

7. Missing Report—277 Health Care Claim Acknowledgment Process Steps. When a bill submitter sends an 837 that requires an attachment and Loop 2300 PWK Segment indicates that a report will be following, the payer will need to respond with the appropriate 277 HCCA response(s) as applicable.

Bill Status Findings	277 HCCA Acknowledgment Options
Clean Bill - Missing Report	<p>When a clean bill is missing a required report, the payer needs to place the bill in a pre-adjudication hold (pending) status during the specified waiting time period and return the following Claim Status Category Code and Claim Status Code:</p> <p>STC01-1 = A1 The claim/encounter has been received. This does not mean that the claim has been accepted for adjudication.</p> <p>STC01-2 = 21 (Missing or Invalid Information)</p> <p>AND</p> <p>STC10-1 = A1 The claim/encounter has been received. This does not mean that the claim has been accepted for adjudication.</p> <p>STC10-2 = Use the appropriate 277 Claim Status Code for missing report type. Example: Claim Status Code 294 Supporting documentation</p> <p>Example :STC*A1:21*20090830*WQ*70*****A1:294-:</p>
Report Received within the 5 day pre-adjudication hold (pending) period	<p>Use the following Claim Status Category Code with the appropriate Claim Status Code:</p> <p>STC01-1= A2 Acknowledgment/Acceptance into adjudication system. The claim/encounter has been accepted into the adjudication system.</p> <p>STC01-2=20 Accepted for processing</p>
No Report Received within the 5 day pre-adjudication hold (pending) period	<p>Use the following Claim Status Category Code and Claim Status Code.</p> <p>STC01-1= A6 Acknowledgment/Rejected for Missing Information. The claim/encounter is missing the information specified in the Status details and has been rejected.</p> <p>STC01-2=294 Supporting documentation</p>

8. Transmission Responses

a. Acknowledgments. The ASC X12 transaction sets include a variety of acknowledgments to inform the sender about the outcome of transaction processing. Acknowledgments are designed to provide information regarding whether or not a transmission can be processed, based on structural, functional, and/or application level requirements or edits. In other words, the acknowledgments inform the sender regarding whether or not the medical bill can be processed or if the transaction contains all the required data elements. Under Electronic Billing (LAC 40:I.Chapter 3) payers must return one of the following acknowledgments, as appropriate, according to the Bill Acknowledgment Flow and Timing Diagrams found in Section 9.1:

- i. TA1—Implementation Acknowledgment
- ii. 005010X231—Implementation Acknowledgment (999)
- iii. 005010X214—Health Care Claim Acknowledgment (277)

iii. Detailed information regarding the content and use of the various acknowledgments can be found in the applicable *ASC X12N Type 3 Technical Reports (Implementation Guides)*.

b. 005010X213—Request for Additional Information. The 005010X213, or Request for Additional Information, is used to request missing required reports from the submitter. The following are the STC01 values:

i. Claim was pending; additional documentation required.

(a). STC01-1=R4 (pending/request for additional supporting documentation)

(b). STC01-2=The LOINC code indicating the required documentation

ii. Additional information regarding this transaction set may be found in the applicable *ASC X12N Type 3 Technical Reports (Implementation Guides)*.

c. 005010X221A1—Health Care Claim Payment/Advice. Within 30 calendar days of receipt of a complete electronic medical bill, the claims administrator is required to send the health care provider the 005010X221A1, if mutually agreed upon pursuant to LAC 40:I.Chapter 3, or Health Care Claim Payment/Advice or other form of paper EOR. This transaction set informs the health care provider about the payment action the claims administrator has taken. Additional information regarding this transaction set may be found in Chapter 7 of this companion guide and the applicable ASC X12N Type 3 Technical Reports Implementation Guides.

d. 005010X212 Health Care Claim Status Request and Response. The 005010X212 transaction set is used in the group health industry to inquire about the current status of a specified healthcare bill or bills. The 276 transaction set identifier code is used for the inquiry and the 277 transaction set identifier code is used for the reply. It is possible to use these transaction sets unchanged in workers' compensation bill processing. Additional information regarding this transaction set may be found in the applicable ASC X12N Type 3 Technical Reports Implementation Guides.

J. Appendix A—Glossary of Terms

Acknowledgment—electronic notification to original sender of an electronic transmission that the transactions within the transmission were accepted or rejected.

ADA—American Dental Association.

ADA—2006—American Dental Association (ADA) standard paper billing form.

AMA—American Medical Association

ANSI—American National Standards Institute, a private, non-profit organization that administers and coordinates the U.S. voluntary standardization and conformity assessment system.

ASC X12 275—a standard transaction developed by ASC X12 to transmit various types of patient information.

ASC X12 835—a standard transaction developed by ASC X12 to transmit various types of health care claim payment/advice information.

ASC X12 837—a standard transaction developed by ASC X12 to transmit various types of health care claim information.

CDT—current dental terminology, coding system used to bill dental services.

Complete Bill—a complete electronic medical bill and its supporting transmissions must:

- a. be submitted in the correct billing format, with the correct billing code sets,
- b. be transmitted in compliance with all necessary format requirements
- c. include in legible text all medical reports and records, including, but not limited to, evaluation reports, narrative reports, assessment reports, progress report/notes, clinical notes, hospital records and diagnostic test results that are expressly required by law or can reasonably be expected by the payer or its agent under the Jurisdiction's law
- d. include any other jurisdictional requirements found in its regulations or companion guide.

Clearinghouse—a public or private entity, including a billing service, repricing company, community health management information system or community health information system, and "value-added" networks and switches, that is an agent of either the payer or the provider and that may perform the following functions:

- a. processes or facilitates the processing of medical billing information received from a client in a nonstandard format or containing nonstandard data content into standard data elements or a standard transaction for further processing of a bill related transaction; or
- b. receives a standard transaction from another entity and processes or facilitates the processing of medical billing information into a nonstandard format or nonstandard data content for a client entity. An entity that processes information received in a nonstandard format or containing nonstandard data content into a standard transaction, or that receives a standard transaction and processes that information into a nonstandard transaction.

CMS—Centers for Medicare and Medicaid Services, the federal agency that administers these programs.

MS—1450—the paper hospital, institutional, or facility billing form, also referred to as a UB—04 or UB—92, formerly referred to as a HCFA—1450.

CMS—1500—the paper professional billing form formerly referred to as a HCFA or HCFA—1500.

Code Sets—tables or lists of codes used for specific purposes. National standard formats may use code sets developed by the standard setting organization (i.e. X12 Provider Type qualifiers) or by other organizations (i.e. HCPCS codes).

CPT—current Procedural Terminology, the coding system created and copyrighted by the American Medical Association that is used to bill professional services.

DEA—Drug Enforcement Administration.

DEA Number—prescriber DEA identifier used for pharmacy billing.

Detail Acknowledgment—electronic notification to original sender that its electronic transmission or the transactions within the transmission were accepted or rejected.

Electronic Bill—a bill submitted electronically from the health care provider, health care facility, or third-party biller/assignee to the payer.

EFT—electronic funds transfer.

Electronic Transmission—a collection of data stored in a defined electronic format. An electronic transmission may be a single electronic transaction or a set of transactions.

Electronic Format—the specifications defining the layout of data in an electronic transmission.

Electronic Record—a group of related data elements. A record may represent a line item, a health care provider, health care facility, or third party biller/assignee, or an employer. One or more records may form a transaction.

Electronic Transaction—a set of information or data stored electronically in a defined format that has a distinct and different meaning as a set. An electronic transaction is made up of one or more electronic records.

Electronic Transmission—transmission of information by facsimile, electronic mail, electronic data interchange, or any other similar method that does not include telephonic communication. For the purposes of the electronic billing rules, electronic transmission generally does not include facsimile or electronic mail.

EOB/EOR—explanation of benefits (EOB) or explanation of review (EOR) is the paper form sent by the payer to the health care provider, health care facility, or third party biller/assignee to explain payment or denial of a medical bill. The EOB/EOR might also be used to request recoupment of an overpayment or to acknowledge receipt of a refund.

Functional Acknowledgment—electronic notification to the original sender of an electronic transmission that the functional group within the transaction was accepted or rejected.

HCPCS—Healthcare Common Procedure Coding System, the HIPAA code set used to bill durable medical equipment, prosthetics, orthotics, supplies, and biologics (Level II) as well as professional services (Level I). Level I HCPCS codes are CPT codes

HIPAA—Health Insurance Portability and Accountability Act, federal legislation that includes provisions that mandate electronic billing in the Medicare system and establishes national standard electronic file formats and code sets.

IAIABC—International Association of Industrial Accident Boards and Commissions.

IAIABC 837—an implementation guide developed by the IAIABC based on the ASC X12 standard to transmit various types of health care medical bill and payment information from payers to Jurisdictional workers' compensation agencies.

ICD—9—International Classification of Diseases, the code set administered by the World Health Organization used to identify diagnoses.

NABP—National Association of Boards of Pharmacy, the organization previously charged with administering pharmacy unique identification numbers. See NCPDP.

NABP Number—identification number assigned to an individual pharmacy, administered by NCPDP. (Other term: NCPDP Provider ID)

NCPDP—National Council for Prescription Drug Programs, the organization administering pharmacy—unique identification numbers called NCPDP Provider IDs.

NCPDP Provider ID Number—identification number assigned to an individual pharmacy, previously referred to as NABP number.

NCPDP WC/PC UCF—National Council for Prescription Drug Programs Workers' Compensation/Property and Casualty Universal Claim form,

the pharmacy industry standard for pharmacy claims billing on paper forms.

NCPDP Telecommunication D.0—HIPAA compliant national standard billing format for pharmacy services.

NDC—National Drug Code, the code set used to identify medication dispensed by pharmacies.

Payer—the entity responsible, whether by law or contract, for the payment of the medical expenses incurred by a claimant as a result of a work related injury.

Receiver—the entity receiving/accepting an electronic transmission.

Remittance—remittance is used in the electronic environment to refer to reimbursement or denial of medical bills.

Sender—the entity submitting an electronic transmission.

Trading Partner—an entity that has entered into an agreement with another entity to exchange data electronically.

UB—04—universal billing form used for hospital billing. Replaced the *UB—92* as the *CMS—1450* billing form effective May 23, 2007.

UB—92—universal billing form used for hospital billing, also referred to as a *CMS—1450* billing form. Discontinued use as of May 23, 2007

Version—electronic formats may be modified in subsequent releases. Version naming conventions indicate the release or version of the standard being referenced. Naming conventions are administered by the standard setting organization. Some ASC X12 versions, for example, are 3050, 4010, and 4050.

AUTHORITY NOTE: Promulgated in accordance with R.S. 23:1310.1.

HISTORICAL NOTE: Promulgated by the Louisiana Workforce Commission, Office of Workers Compensation Administration, LR 39:

Family Impact Statement

Implementation of this proposed Rule should not have any known or foreseeable impact on any family as defined by R.S. 49:972(D) or on any family formation, stability, and autonomy. This proposed Rule shall not have any impact on the six criteria set out in R.S. 49:972(D).

Small Business Statement

The impact of the proposed Rule on small business has been considered and it is estimated that the proposed action is not expected to have a significant adverse impact on small business as defined in the Regulatory Flexibility Act. The agency, consistent with health, safety, environmental and economic welfare factors has considered and, where possible, utilized regulatory methods in the drafting of the proposed Rule that will accomplish the objectives of applicable statutes while minimizing the adverse impact of the proposed Rule on small businesses.

Public Comments

The proposed amendments create the Electronic Medical Billing and Payment Companion Guide. The proposed Electronic Medical Billing and Payment Companion Guide will give detailed information for electronic billing and payment. The guide outlines the workers' compensation industry national standards and Louisiana jurisdictional procedures necessary for engaging in electronic data interchange (EDI) and specifies clarifications where applicable.

Inquiries concerning the proposed amendments may be directed to Director, Office of Workers' Compensation Administration, Louisiana Workforce Commission, P.O. Box 94040, Baton Rouge, LA 70804-9040.

Interested parties may submit data, views, arguments, information or comments on the proposed amendment in writing to the Louisiana Workforce Commission, Office of Workers' Compensation, P.O. Box 94040, Baton Rouge, Louisiana 70804-9040., Attention: Director, Office of Workers' Compensation Administration. Written comments must be submitted and received by the Department within 20 days from the publication of this notice. A request pursuant to R.S. 49:953(A)(2) for oral presentation, argument or public hearing must be made in writing and received by the department within 20 days of the publication of this notice.

Public Hearing

A public hearing will be held on November 27, 2012 at 9:30 AM at the LWC 4th Floor Auditorium, 1001 N. 23rd Street, Baton Rouge, LA 70802.

Curt Eysink
Executive Director

FISCAL AND ECONOMIC IMPACT STATEMENT FOR ADMINISTRATIVE RULES RULE TITLE: **Electronic Medical Billing and Payment Companion Guide**

I. ESTIMATED IMPLEMENTATION COSTS (SAVINGS) TO STATE OR LOCAL GOVERNMENT UNITS (Summary)

The proposed rule change will have no impact on state or local government expenditures. The proposed rule change adds an electronic medical billing and payment companion guide. This companion guide contains data clarifications derived from specific business rules that apply to processing bills and payments electronically within the Louisiana workers' compensation system and in furtherance of LSA-R.S. 23:1203.2.

The Division of Administration indicates that the proposed rule will have no fiscal impact on the Office of Risk Management.

II. ESTIMATED EFFECT ON REVENUE COLLECTIONS OF STATE OR LOCAL GOVERNMENTAL UNITS (Summary)

The implementation of the electronic medical billing and payment companion guide will have no anticipated effect on revenue collections of state or local governmental units.

III. ESTIMATED COSTS AND/OR ECONOMIC BENEFITS TO DIRECTLY AFFECTED PERSONS OR NONGOVERNMENTAL GROUPS (Summary)

Implementation of this proposed rule will have no impact on directly affected persons or non-governmental groups. For all affected parties, the proposed electronic medical billing and payment companion guide will give detailed information for electronic billing and payment. The guide outlines the workers' compensation industry national standards and Louisiana jurisdictional procedures necessary for engaging in electronic data interchange (EDI) and specifies clarifications where applicable.

IV. ESTIMATED EFFECT ON COMPETITION AND EMPLOYMENT (Summary)

There is no anticipated direct effect on competition and employment.

Wes Hataway
Director
1210#047

Evan Brasseur
Staff Director
Legislative Fiscal Office

LAC Title	Part.Section	Effect	Location LR 38 Month Page	LAC Title	Part.Section	Effect	Location LR 38 Month Page		
40	I.2915	Amended	Mar. 836	46	LXXX.901,903,905,907,909,911,917,921	Amended	April 1022		
	I.2718	Adopted	April 1030		LXXX.906,908,913,915,929	Adopted	April 1022		
42	III.Chapters 17,19,21,23,25,27,29,31,33,34	Adopted	July 1601	LXXX.919,925	Repromulgated	April 1022			
	III.Chapters 35,39,40,41,42,43,42,47	Adopted	July 1601	LXXX.923,927	Amended	April 1022			
	VII.Chapters 17,19,21,23,25,27,29,33,35,41	Repealed	July 1601	LXXXV.303,400,405,500,503	Amended	July 1591			
	VII.Chapters 42,43,45	Repealed	July 1601	LXXXV.712,1103,1105,1200,1201,1211	Amended	Feb. 356			
	IX.Chapters 19,21,23,25,27,29,31,33,35,39	Repealed	July 1601	LXXXV.1209	Adopted	Feb. 356			
	IX.Chapters 41,42,43,45	Repealed	July 1601	XCI.801	Amended	Aug. 1960			
	XIII.Chapters 17,19,21,23,25,27,29,31,33,35	Repealed	July 1601	48	I.4203,4207,4227,4245,4267	Amended	Sept. 2372		
	XIII.Chapters 39,40,41,42,43,45	Repealed	July 1601		I.5001	Amended	June 1410		
	43	I.1101,1102,1103,1104,1107,1108,1109,1110	Adopted		Jan. 125	I.5001,5003,5005,5007,5009,5011,5013,5015	Adopted	Jan. 63	
		I.1111,1112,1113,1114,1115,1116,1117,1118	Adopted		Jan. 125	I.5016,5017,5019,5021,5023,5025,5027,5029	Adopted	Jan. 63	
I.1119,1120,1121,1122,1123,1124,1125,1129		Adopted	Jan. 125		I.5031,5033,5035,5037,5039,5041,5043,5045	Adopted	Jan. 63		
I.1130,1131,1132,1133,1134,1135,1136,1137		Adopted	Jan. 125		I.5049,5051,5053,5055,5057,5059,5061,5063	Adopted	Jan. 63		
I.1138,1139,1140,1141,1142,1145,1146,1147		Adopted	Jan. 125		I.5071,5073,5075,5077,5079,5081,5083,5085	Adopted	Jan. 63		
I.1148,1153,1154,1155,1156,1157,1161,1162		Adopted	Jan. 125		I.5087,5089,5090,5091,5093,5094,5095,5099	Adopted	Jan. 63		
I.1163,1164,1165,1166,1167,1168,1169,1175		Adopted	Jan. 125		I.6201,6203,6207,6209,6211,6213,6215,6217	Adopted	Feb. 401		
I.1176,1177		Adopted	Jan. 125		I.6219,6221,6223,6225,6227,6229,6233,6237	Adopted	Feb. 401		
V.401,403,405,407,409,411,413		Repealed	Jan. 125	I.6239,6241,6245,6247,6249,6251,6253,6255	Adopted	Feb. 401			
XI.101		Repromulgated	June 1414	I.6259,6261,6265,6267,6269,6271,6273,6275	Adopted	Feb. 401			
44	XIII.301,303,305,307,309,311,313,315,317	Amended	Jan. 110	I.6279,6281,6285,6287,6289,6291,6293,6295	Adopted	Feb. 401			
	XIII.312,322,2731,3501,3503,3505,3507	Adopted	Jan. 110	I.9001,9001,9031,9033,9035,9037,9041,9049	Amended	Feb. 371			
	XIII.319	Repealed	Jan. 110	I.9007,9009,9011,9013,9015,9017,9019,9021	Adopted	Feb. 371			
	XIII.321,503,507,713,715,912,921,1105	Amended	Jan. 110	I.9023,9025,9027,9029,9043,9045,9047,9063	Adopted	Feb. 371			
	XIII.923,2720	Repromulgated	Mar. 828	I.9051,9061,9065,9067,9071,9075,9077,9079	Amended	Feb. 371			
	XIII.1151,1511,1513,1933,2117,2705,2715	Amended	Jan. 110	I.9069,9083,9085,9087,9089,9091,9093,9095	Adopted	Feb. 371			
	XIII.2716,2911,3323,3325,3331,3335,3339	Amended	Jan. 110	I.9081	Amended	Feb. 371			
	XIII.3345,3351,5103	Amended	Jan. 110	I.9097	Adopted	Feb. 371			
	XIII.3509,3511,3513,3515	Adopted	Jan. 110	I.9303,9305,9377	Amended	June 1413			
	45	I.1305	Amended	July 1587	I.9741,9743	Amended	Mar. 824		
I.1315		Amended	April 1012	I.10001,10011,10013,10015,10017,10019	Amended	May 1241			
XXI.1103		Amended	Aug. 1957	I.10015,10081	Repromulgated	June 1410			
XXIX.101,103,105,107,109,111,113,115,301		Amended	Jan. 148	I.10021,10023,10025,10033,10035,10045	Amended	May 1241			
XXIX.110		Adopted	Jan. 148	I.10055,10057,10059,10061,10071,10073	Amended	May 1241			
XXIX.307,309,311,315,317,501,503,505,507		Amended	Jan. 148	I.10079,10081,10082,10083,10084,10085	Amended	May 1241			
XXIX.509,511,513,515,517,519,521,701,703		Amended	Jan. 148	I.10086,10088,10089,10090	Amended	May 1241			
XXIX.901,903,1103,1109,1111,1113,1301		Amended	Jan. 148	I.10091	Repealed	May 1241			
XXIX.1501,1503,1505,1507,1509		Amended	Jan. 148	I.12501,12503	Amended	Aug. 1961			
XXIX.1511,1513		Adopted	Mar. 813	I.12503,12505	Amended	July 1593			
46	XXXIII.124,306,403,409,415,1611,1709	Repromulgated	Feb. 355	I.12524	Adopted	Aug. 1961			
	XXXIII.318	Amended	Aug. 1960	I.12526	Adopted	July 1593			
	XXXIII.1505,1507,1509,1611	Amended	Aug. 1958	50	I.2901,2903,2905,2907,2909,2911,2913,2915	Repealed	Sept. 2370		
	XXXIII.1611,1615	Amended	Mar. 817		II.20001,20007,20013,20015	Amended	Mar. 825		
	XXXIII.1709,1711	Amended	Aug. 1959		II.20005	Amended	May 1241		
	XXXIII.1711	Repromulgated	Feb. 355		V.109	Adopted	Aug. 1962		
	XXXIX.101,301,901	Amended	July 1589		V.301	Amended	Mar. 824		
	XLI.1903,1904,1905	Amended	April 1018		V.551	Adopted	May 1241		
	XLV.1906,1907	Amended	April 1018		V.1125,1127	Amended	May 1240		
	XLV.193,195,2501,2505,2507,2510,2511	Amended	Jan. 52		V.5113	Amended	Aug. 1963		
XLV.2513,2525,2527,2529,2531,2533,2535	Repealed	Jan. 52	V.5311,5511,5711,5911,6113		Amended	May 1251			
XLV.2515,2517,2519,2521,2523,2536,2537	Amended	Jan. 52	IX.15107		Adopted	Aug. 1964			
XLV.2539	Repealed	Jan. 52	IX.15155	Adopted	Aug. 1964				
47	XLV.2540,2541,2543,2545,2547,2548,2549	Amended	Jan. 52	XI.Chapter 17	Repealed	Feb. 366			
	XLV.2551,2553,2555,2557,2559,2561,2563	Amended	Jan. 52	XI.7501	Amended	Aug. 1961			
	XLV.2565,2567,2569,2571,2575,5501,5505	Amended	Jan. 52	XV.Chapters 1-13	Repealed	Feb. 366			
	XLV.2573	Adopted	Jan. 52	XV.7701,7703,7705,7707,9133	Repealed	Feb. 365			
	XLV.3149 (HCR#69)	Amended	June 1460	XV.9101,9113,9121	Amended	Feb. 365			
	XLV.3509	Amended	April 1026	XV.9301,9303,9305,9307	Adopted	Sept. 2371			
	XLV.4507	Amended	May 1233	XXI.2915	Amended	July 1594			
	XLV.5507,5509,5517,5519	Amended	Jan. 52	XXII.6101,6103,6301,6303,6501,6503,6501	Adopted	Mar. 820			
	XLVII.3331	Amended	Mar. 818	XXII.6503,6701,6703,6901,6903	Adopted	Mar. 820			
	XLIX.713	Amended	Jan. 51	XXIX.117	Amended	Feb. 368			
48	LI.301,503,603	Amended	July 1590	XXXIII.101,103,105,107,301,303,305,501	Adopted	Feb. 360			
	LIII.525	Adopted	May 1233	XXXIII.701,901	Adopted	Feb. 360			
	LIII.505,905,1203	Amended	May 1234	XXXIII.2101,2103,2301,2303,2501,2701	Adopted	Feb. 363			
	LIII.1105	Amended	May 1239	XXXIII.4101,4103,4301,4303,4305,4501	Adopted	Feb. 400			
	LIII.1143	Amended	May 1240	XXXIII.4701,4703	Adopted	Feb. 400			
	LIII.1501,1513	Amended	May 1235	XXXIII.6101,6103,6301,6303,6305,6307	Adopted	Feb. 358			
	LIII.1512	Adopted	May 1235	XXXIII.6501,6701	Adopted	Feb. 358			
	LIII.1525	Repealed	May 1240	XXXIII.8101,8103,8303,8305,8501,8701	Adopted	Feb. 366			
	LIII.1801,1803,1805,1807,1809,1811,1813	Adopted	May 1235	XXXIII.10101,10103,10301,10303,10501	Adopted	Feb. 369			
	LIII.1815,1817,1819	Adopted	May 1235	XXXIII.10701,10703,10705,10707	Adopted	Feb. 369			
49	LVII.518	Amended	July 1596	XXXIII.12101,12103,12301,12303,12501	Adopted	Feb. 427			
	LVII.519	Adopted	Sept. 2378	XXXIII.12701,12703,12705,12707	Adopted	Feb. 427			
	LX.3309,3311,3315	Amended	Aug. 1965	XXXIII.14101,14103,14301,14303,14501	Adopted	Feb. 426			
	LX.3317,3319,3321	Adopted	Aug. 1965	XXXIII.14701	Adopted	Feb. 426			
	LXI.105	Amended	Mar. 835	51	I.101	Amended	Sept. 2374		
	LXI.105	Repromulgated	April 1029		I.124	Adopted	Sept. 2374		
	LXI.2305,2701	Amended	June 1418		II.701	Amended	May 1252		
	LXVI.901	Amended	Jan. 97		IX.325,327,331,333	Amended	Jan. 95		
	LXVI.1127,1129	Adopted	Jan. 97		IX.330	Adopted	Jan. 95		
	LXVII.2515	Amended	April 1021		52	I.1201,1203,1205,1207	Amended	May 1207	
LXX.3103,3205,3207,3209,3301	Amended	Sept. 2369	I.1209			Adopted	May 1207		
LXXX.501	Amended	April 1025	53			I.101	Amended	Sept. 2374	
50	I.1305	Amended				July 1587	I.124	Adopted	Sept. 2374
	I.1315	Amended				April 1012	II.701	Amended	May 1252
	XXI.1103	Amended		Aug. 1957		IX.325,327,331,333	Amended	Jan. 95	
	XXIX.101,103,105,107,109,111,113,115,301	Amended		Jan. 148		IX.330	Adopted	Jan. 95	
	XXIX.110	Adopted		Jan. 148		54	I.1201,1203,1205,1207	Amended	May 1207
	XXIX.307,309,311,315,317,501,503,505,507	Amended		Jan. 148			I.1209	Adopted	May 1207
	XXIX.509,511,513,515,517,519,521,701,703	Amended		Jan. 148			55	I.101	Amended
	XXIX.901,903,1103,1109,1111,1113,1301	Amended		Jan. 148	I.124			Adopted	Sept. 2374
	XXIX.1501,1503,1505,1507,1509	Amended		Jan. 148	II.701			Amended	May 1252
	XXIX.1511,1513	Adopted	Mar. 813	IX.325,327,331,333	Amended			Jan. 95	
XXXIII.124,306,403,409,415,1611,1709	Repromulgated	Feb. 355	IX.330	Adopted	Jan. 95				
XXXIII.318	Amended	Aug. 1960	56	I.1201,1203,1205,1207	Amended			May 1207	
XXXIII.1505,1507,1509,1611	Amended	Aug. 1958		I.1209	Adopted			May 1207	
XXXIII.1611,1615	Amended	Mar. 817		57	I.101			Amended	Sept. 2374
XXXIII.1709,1711	Amended	Aug. 1959			I.124	Adopted		Sept. 2374	
XXXIII.1711	Repromulgated	Feb. 355			II.701	Amended		May 1252	
XXXIX.101,301,901	Amended	July 1589			IX.325,327,331,333	Amended	Jan. 95		
XLI.1903,1904,1905	Amended	April 1018			IX.330	Adopted	Jan. 95		
XLV.1906,1907	Amended	April 1018			58	I.1201,1203,1205,1207	Amended	May 1207	
XLV.193,195,2501,2505,2507,2510,2511	Amended	Jan. 52				I.1209	Adopted	May 1207	
XLV.2513,2525,2527,2529,2531,2533,2535	Repealed	Jan. 52				59	I.101	Amended	Sept. 2374
XLV.2515,2517,2519,2521,2523,2536,2537	Amended	Jan. 52	I.124				Adopted	Sept. 2374	
XLV.2539	Repealed	Jan. 52	II.701				Amended	May 1252	
XLV.2540,2541,2543,2545,2547,2548,2549	Amended	Jan. 52	IX.325,327,331,333	Amended			Jan. 95		
XLV.2551,2553,2555,2557,2559,2561,2563	Amended	Jan. 52	IX.330	Adopted			Jan. 95		
XLV.2565,2567,2569,2571,2575,5501,5505	Amended	Jan. 52	60	I.1201,1203,1205,1207			Amended	May 1207	
XLV.2573	Adopted	Jan. 52		I.1209			Adopted	May 1207	
XLV.3149 (HCR#69)	Amended	June 1460		61			I.101	Amended	Sept. 2374
XLV.3509	Amended	April 1026			I.124		Adopted	Sept. 2374	
XLV.4507	Amended	May 1233			II.701		Amended	May 1252	
XLV.5507,5509,5517,5519	Amended	Jan. 52			IX.325,327,331,333	Amended	Jan. 95		
XLVII.3331	Amended	Mar. 818			IX.330	Adopted	Jan. 95		
XLIX.713	Amended	Jan. 51			62	I.1201,1203,1205,1207	Amended	May 1207	
LI.301,503,603	Amended	July 1590				I.1209	Adopted	May 1207	
LIII.525	Adopted	May 1233				63	I.101	Amended	Sept. 2374
LIII.505,905,1203	Amended	May 1234	I.124				Adopted	Sept. 2374	
LIII.1105	Amended	May 1239	II.701				Amended	May 1252	
LIII.1143	Amended	May 1240	IX.325,327,331,333	Amended			Jan. 95		
LIII.1501,1513	Amended	May 1235	IX.330	Adopted			Jan. 95		
LIII.1512	Adopted	May 1235	64	I.1201,1203,1205,1207			Amended	May 1207	
LIII.1525	Repealed								

LAC Title	Part.Section	Effect	Location LR 38		LAC Title	Part.Section	Effect	Location LR 38		
			Month	Page				Month	Page	
52	I.1703	Amended	Aug.	1951	61	I.4372	Adopted	Aug.	1995	
	I.2401,2403,2405,2407,2409,2411,2413,2415	Adopted	May	1209		I.4910	Amended	Sept.	2382	
	I.2417	Adopted	May	1209		V.101,303,304,703,907,1101,1103,1307	Amended	Mar.	799	
	XII.101,105,301,337,355,1101,1301,1701	Amended	Sept.	2374		V.1503,2503,2713,2717,3101,3103,3105	Amended	Mar.	799	
	XII.1903,1911	Amended	Sept.	2374		V.3106,3107	Amended	Mar.	799	
55	I.501,507,509,511,515	Amended	Aug.	1992	67	III.301,303,305,307,309,311,313,315,317	Amended	April	964	
	I.514,516	Adopted	Aug.	1992		III.319,321,323,325,327,329,331,333	Amended	April	964	
	I.1301,1303,1305,1307,1309,1311,1313,1315	Amended	May	1279		III.1983	Amended	Feb.	350	
	I.1301,1307	Repromulgated	June	1415		III.5329,5729	Amended	June	1390	
	III.143,144,145,146,147,148,149,150,151	Adopted	Aug.	1974		III.5501	Amended	July	1558	
	III.152,153,154,155,156,157	Adopted	Aug.	1974		III.7312,7327,7365,7373	Amended	April	981	
	VI.301	Amended	Aug.	1994		III.7328,7378	Adopted	April	981	
	VII.315,3109	Amended	Jan.	144		III.7331,7363	Amended	May	1207	
	VII.317	Amended	May	1286		V.6703,6955,6957,6959,6961,7105,7107	Amended	April	968	
	VII.329,3119	Adopted	May	1285		V.6708,6710	Adopted	April	968	
	VII.3101,3103,3109	Amended	Jan.	145		V.7107,7111,7113,7115,7117,7119,7313	Amended	April	984	
	IX.101,103,105,107,109,111,113,115,117	Amended	May	1254		V.7111	Amended	April	968	
	IX.119,121,123,125,127,129,131,133,135	Amended	May	1254		V.7501,7503,7505,7507,7509,7511,7513	Amended	July	1558	
	IX.139,141,143,145,151,155,159,163,165	Amended	May	1254		V.7515,7517,7519,7521,7523,7525	Amended	July	1558	
	IX.147,173	Repealed	May	1254		VII.221,223	Adopted	Jan.	147	
	IX.166,167,169,171,172,175,177,179,181	Amended	May	1254		VII.203,219	Amended	Jan.	147	
	IX.183,201,203,205,207,301,1501,1503,1505	Amended	May	1254		70	XI.101	Adopted	Sept.	2380
	IX.1507,1509,1511,1513,1515,1517,1519	Amended	May	1254			XI.301,303,305	Adopted	Sept.	2379
	IX.1521,1523,1525,1527,1529,1531,1533	Amended	May	1254			71	I.501	Amended	Jan.
	IX.1535,1537,1539,1541,1543,1545,1547	Amended	May	1254		76		I.701,703,705,707,709	Adopted	Aug.
XIII.101,103,105,301,303,305	Adopted	April	1019	V.115 (House Committee Report [HCR]#6)	Amended			June	1459	
XXI.101,103,105,301,303,305,307,309,311	Amended	Jan.	48	V.130	Adopted			Aug.	1997	
XXI.501,503	Adopted	Jan.	48	VII.157	Amended		July	1732		
58	I.2511,2513	Amended	Mar.	836	VII.158	Adopted	July	1732		
	I.2521,2523	Repealed	Mar.	836	VII.335	Amended	Sept.	2383		
	V.101	Amended	Mar.	796	VII.361	Amended	June	1419		
	V.501	Amended	April	1011	VII.367	Amended	Jan.	146		
	V.503,505	Repealed	April	1011	VII.371,525	Amended	Aug.	1997		
	V.2003,2005	Adopted	April	1012	VII.901	Repromulgated	Feb.	433		
	XVII.101,103,105	Adopted	April	1029	XIX.101,103	Amended	July	1747		
					XIX.111	Amended	July	1732		
61	I.1515	Amended	Sept.	2382						
	I.4415	Repealed	Aug.	1995						

Potpourri

POTPOURRI

Department of Agriculture and Forestry Horticulture Commission

Landscape Architect State Exam

The next landscape architect state examination will be given December 3, 2012, beginning at 9 a.m. at the Nelson Memorial Building, Louisiana State University Campus, Baton Rouge, LA. The deadline for sending the application and fee is November 16, 2012.

Further information pertaining to the examinations may be obtained from Tad Hardy, Director, Horticulture Commission, P.O. Box 3596, Baton Rouge, LA 70821-3596, phone (225) 952-8100.

Any individual requesting special accommodations due to a disability should notify the office prior to November 16, 2012. Questions may be directed to (225) 952-8100.

Mike Strain, DVM
Commissioner

1210#001

POTPOURRI

Board of Elementary and Secondary Education

Bulletin 133—Scholarship Programs (LAC 28:CLIII.1301-1305)

On July 24, 2012, the State Board of Elementary and Secondary Education approved as a Notice of Intent revisions to *Bulletin 133—Scholarship Programs*: Chapter 13. Criteria for School Participation in the Student Scholarships for Educational Excellence Program; §1301. Purpose, §1303. Participation Criteria for Nonpublic Schools, and §1305. Accountability Standards for Participating Nonpublic Schools. The Notice of Intent was published on pages 2389-2391 of the September 20, 2012, issue of the *Louisiana Register* and a request for a public hearing was received. In accordance with RS 49:953.A(2)(a) and RS 49:953.A(2)(b)(i), the State Board of Elementary and Secondary Education will hold a public hearing on October 25, 2012, from 2-4 p.m. in Room 1-100, the Louisiana Purchase Room, located in the Claiborne Building, 1201 North Third Street, Baton Rouge, Louisiana.

Heather Cope
Executive Director

1210#036

POTPOURRI

Department of Health and Hospitals Office of Public Health

Public Hearing—Substantive Changes to Proposed Rule Amendments—Accreditation of Laboratories Conducting Drinking Water Analyses (LAC 48:V.Chapter 80 and LAC 51:XII.101.301)

In the December 20, 2011 edition of the *Louisiana Register* (LR 37:3658-3675), the Louisiana Department of Health and Hospitals, Office of Public Health (DHH-OPH) published a Notice of Intent to adopt a set of new regulations within LAC 48:V.Chapter 80 governing the accreditation of laboratories performing drinking water analyses for public water systems and for other potable water supplies. In addition, this same Notice of Intent proposed to additionally amend DHH-OPH's existing rule in LAC 51:XII in order to make the current Sanitary Code regulations comport with the set of new laboratory accreditation regulations proposed to be housed in LAC 48:V.Chapter 80. The notice solicited views, arguments, information, written comments and testimony. As a result of its consideration of the written comments and testimony received, DHH-OPH proposes to amend the proposed rule. Substantive changes are being made to Subsections 8017.B, 8017.J, 8057.D, 8064, 8075.D, 8079.B, 8079.C, and 8079.G. These provisions will read as set forth below.

In accordance with R.S. 49:968(H)(2), DHH-OPH will conduct a public hearing concerning these substantive changes at 9 a.m. on Monday, November 19, 2012, in Room 372 (3rd floor) of the Bienville Building, 628 North Fourth Street, Baton Rouge, LA. Persons attending the hearing may have their parking ticket validated when one parks in the 7-story Galvez Parking Garage which is located between N. Sixth and N. Fifth/North and Main Sts. (catercorner and across the street from the Bienville Building).

Title 48

PUBLIC HEALTH—GENERAL

Part V. Preventive Health Services

Subpart 28. Drinking Water Laboratories

Chapter 80. Accreditation of Laboratories Performing Drinking Water Analyses

Subchapter B. Program Procedures and Requirements

§8017. Requirements for Accreditation

A. - A.5. ...

B. To be clear, the requirements of LAC 48:V.8009.A.1 and 8009.A.2 shall apply to all laboratories regardless of the number of categories specified in §8019 for which the laboratory is seeking accreditation. The requirements of

Paragraphs 8019.A.1, 8019.A.2 and 8019.A.3 shall apply dependent upon the particular category or categories for which the laboratory is seeking accreditation.

C. - J. ...

1. Notwithstanding the general requirements of Subsection J above, a laboratory seeking State of Louisiana drinking water laboratory certification only may be allowed, at the discretion of the department, to meet less than the more stringent requirement(s) [e.g., see Subsection 8031.A wherein a lesser frequency of proficiency analyses is acceptable as compared to Subsection 8031.C's frequency of proficiency analyses requirements (which is applicable to a laboratory seeking TNI certification)]. The department shall require laboratories seeking or maintaining only a State of Louisiana drinking water laboratory certification to comply with Paragraphs 8009.A.1, 8009.A.2 and 8009.A.4. Paragraph 8009.A.3 is applied only when a laboratory is seeking or maintaining a TNI certification.

K. ...

AUTHORITY NOTE: Promulgated in accordance with R.S. 36:254(B)(7).

HISTORICAL NOTE: Promulgated by the Department of Health and Hospitals, Office of Public Health, LR 38:

§8057. Quality Assurance for Environmental Testing

A. - C. ...

D. Control charts, generated from the laboratory's control sample (however named), shall be maintained by the laboratory. Until sufficient data are available from the laboratory, usually a minimum of 20 to 30 test results on a specific analysis, the laboratory shall use the control limits (if specified) in the method. When sufficient data becomes available, the laboratory shall develop control charts from the mean percent recovery (\bar{X}) and the standard deviation (S) of the percent recovery for the Quality Control (QC) checks specified in the above Subsections of this Section (also, see Chapter VI of the *Handbook for Analytical QC in Water and Wastewater Laboratories*, EPA-600/4-79-019 or *Standard Methods for the Examination of Water and Wastewater*, 20th edition, Part 1020B, or similar laboratory analytical QC reference texts for further information). These data are used to establish upper and lower control limits as follows:

1. upper control limit = $\bar{X} + 3S$
(upper warning limit, use + 2S instead of + 3S);

2. lower control limit = $\bar{X} - 3S$
(lower warning limit, use - 2S instead of - 3S).

E. ...

AUTHORITY NOTE: Promulgated in accordance with R.S. 36:254(B)(7).

HISTORICAL NOTE: Promulgated by the Department of Health and Hospitals, Office of Public Health, LR 38:

Subchapter D. Criteria and Procedures for Radiological/Radiochemical Testing and Analysis

§8064. General

A. This Subchapter, in conjunction with other requirements contained in other portions of this Chapter, establishes the department's requirements to which an accredited laboratory or laboratory seeking accreditation shall continually meet and follow when performing radiological/radiochemical analyses.

AUTHORITY NOTE: Promulgated in accordance with R.S. 36:254(B)(7).

HISTORICAL NOTE: Promulgated by the Department of Health and Hospitals, Office of Public Health, LR 38:

§8075. Quality Assurance for Radiochemical Testing

A. - C. ...

D. Laboratories which have received accreditation or are seeking accreditation to perform any of the required radiological/radiochemical analyses, shall maintain control charts for each instrument and method used by the laboratory for compliance monitoring sample measurements. Instrument initial calibrations and all efficiency and instrument background checks shall be maintained in a permanent record. Control charts shall be maintained as specified in Chapter VI of the *USEPA Manual for the Certification of Laboratories Analyzing Drinking Water*. Until sufficient data are available from the laboratory, usually a minimum of 20 to 30 test results on a specific analysis, the laboratory shall use the control limits (if specified) in the method. When sufficient data becomes available, the laboratory shall develop control charts from the mean percent recovery (\bar{X}) and the standard deviation (S) of the percent recovery for the Quality Control (QC) checks specified in the above Subsections of this Section (also, see Chapter VI of the *Handbook for Analytical QC in Water and Wastewater Laboratories*, EPA-600/4-79-019 or *Standard Methods for the Examination of Water and Wastewater*, 20th Edition, Part 1020B, or similar laboratory analytical QC reference texts for further information). These data are used to establish upper and lower control limits as follows:

1. upper control limit = $\bar{X} + 3S$
(upper warning limit, use + 2S instead of + 3S);

2. lower control limit = $\bar{X} - 3S$
(lower warning limit, use - 2S instead of - 3S).

E. ...

AUTHORITY NOTE: Promulgated in accordance with R.S. 36:254(B)(7).

HISTORICAL NOTE: Promulgated by the Department of Health and Hospitals, Office of Public Health, LR 38:

§8079. General Laboratory Practices

A. ...

B. Reagent Water. The laboratory shall have a source of reagent water meeting the requirements of being an American Society of Testing Materials (ASTM) Type 1, 2, or 3 reagent water, having a minimum resistivity of 10 megohms/cm (conductivity less than 0.1 microhms/cm) at 25°C. It shall be monitored daily by measuring the reagent water's conductivity or resistivity and documented. Radioactive components have been known to break through reagent water manufacturing units before an increase in resistivity is noted. To monitor the background radioactivity of the reagent water, it is to be screened for radioactivity each time the treatment unit is serviced, and periodically thereafter depending on the volume of reagent water use at the laboratory between servicing units.

C. Glassware Preparation. Specific requirements in the methods for the cleaning of glassware must be followed. The purpose of these requirements are to minimize the possibility that glassware can contaminate samples, and should include acid rinsing. Acid rinsing not only mobilizes any metals remaining adhering to their surfaces, but also hydrates the outer silica layer on the glassware which inhibits contamination with radioactive materials. If there are no specifications for cleaning glassware in the method, then the

glassware should first be washed in detergent solution, then thoroughly rinsed in tap water followed by a second rinse in a dilute acid solution, and finally rinsed with reagent water and dried.

D. - F. ...

G. **Compositing of Samples.** If deemed acceptable by the department, samples may be composited by the utility or the laboratory, provided that all the sample aliquots are properly preserved at the time of collection. Since the required compliance protocol monitoring measurements is "total activity" (i.e., the composited sample is required to represent the maximum potential exposure from drinking water), samples shall not be filtered before preservation. Samples must be drawn on a quarterly basis and where compositing is not done by the laboratory, there shall be documentation submitted with the composited sample detailing on what particular day(s) each aliquot was obtained, its volume, and when it was preserved. A sample of the preservative itself shall accompany the composited sample to the laboratory to determine the contribution of radioactivity, if any, from the addition of the preservative to the sample. Analysis of the composited sample shall be completed within 1 year after the first sample is collected or within normal holding times if the compositing period is less than 90 days. Wherever possible, the laboratory should be responsible for managing the compositing of samples.

AUTHORITY NOTE: Promulgated in accordance with R.S. 36:254(B)(7).

HISTORICAL NOTE: Promulgated by the Department of Health and Hospitals, Office of Public Health, LR 38:

Bruce Greenstein
Secretary

FISCAL AND ECONOMIC IMPACT STATEMENT FOR ADMINISTRATIVE RULES

RULE TITLE: Public Hearing—Substantive Changes to Proposed Rule Amendments—Accreditation of Laboratories Conducting Drinking Water Analyses

I. ESTIMATED IMPLEMENTATION COSTS (SAVINGS) TO STATE OR LOCAL GOVERNMENT UNITS (Summary)

The proposed rule enacts Chapter 80, Part V, Title 48 and amends Sections 101 and 301, Part XII, Title 51 of the Louisiana Administrative Code. This proposed rule change will amend the September 1989 DHH "Laboratory Certification Manual" which was adopted effective November 20, 1989, in order to include an optional set of standards set by the National Environmental Laboratory Accreditation Program (NELAP). The rule seeks to codify and update the existing state drinking water laboratory accreditation requirements and add new requirements for those laboratories which seek to obtain the stricter TNI certification level. The major purpose of this proposed rule change is to ensure that drinking water samples collected and analyzed pursuant to the Federal Safe Drinking Water Act regulations (40 CFR 141 and 40 CFR 143) meet quality control and quality assurance requirements.

Sample results which meet the quality control and quality assurance requirements are used by public water systems and DHH-OPH's Safe Drinking Water Program to ensure that the health of the citizens and visitors to the State of Louisiana are being protected. These regulations will govern the laboratory accreditation and standards of performance for laboratories conducting drinking water analyses for public water systems

and for other potable water supplies located in the State of Louisiana.

This rule change is not anticipated to have any impact on state laboratories since NELAP regulations are already in practice in state operated laboratories. In addition, it is anticipated that the proposed rule will not have any significant impact on local government units. However, local governmental units (e.g., municipal laboratories) which are currently accredited under the existing rule may experience a minimal increase in costs should they seek to obtain the stricter TNI level of certification. Such costs are relative to the revision of internal documents to meet the requirements of TNI certification contained in this new rule. These documents include quality assurance and control documents required under the new rule.

Municipal laboratories seeking to meet the stricter TNI accreditation requirements will have to complete the new application and create the quality assurance and control documents required by this rule and make the changes in their laboratory operations to bring the laboratory into compliance with the TNI requirements outlined in this rule. Costs will depend upon the laboratory's current level of expertise.

The proposed rule changes will result in an estimated cost to DHH-OPH of \$5,733 to publish the notice of intent, the potpourri notice of substantive changes and the final rule in the *Louisiana Register* (\$2,772 in FY 12 and \$2,961 in FY 13). This is a one-time cost that will be absorbed by the agency's budget.

II. ESTIMATED EFFECT ON REVENUE COLLECTIONS OF STATE OR LOCAL GOVERNMENTAL UNITS (Summary)

There are no effects on revenue collections of state or local governmental units anticipated as a result of promulgation of this regulation.

III. ESTIMATED COSTS AND/OR ECONOMIC BENEFITS TO DIRECTLY AFFECTED PERSONS OR NONGOVERNMENTAL GROUPS (Summary)

The non-governmental groups (e.g., owners of private or commercial laboratories) should see an economic benefit from the promulgation of this rule because the laboratories will be able to market their services as meeting widely accepted national standards for the operation of environmental laboratories under NELAP.

Owners of private or commercial laboratories which are currently accredited under the existing rule, may experience minimal costs should they choose to obtain accreditation under the stricter TNI accreditation requirements authorized by this rule. Such costs are relative to the revision of internal documents to meet the quality assurance and control requirements in this new rule.

Any non-governmental groups (e.g., owners of private or commercial laboratories) seeking accreditation under the stricter TNI accreditation requirements will have to complete the new application and create the quality assurance and control documents to bring the laboratory into compliance with the requirements outlined in this rule. Costs will depend upon the laboratory's current level of expertise.

IV. ESTIMATED EFFECT ON COMPETITION AND EMPLOYMENT (Summary)

Competition in the public and private sectors should be enhanced by the adoption of this rule. Public and private sector laboratories accredited to NELAP standards will be able to compete on a much broader scale nationally if they choose to do so. Employment opportunities may increase if the increased competition leads to more business for these laboratories.

J.T. Lane
Assistant Secretary
1210#046

John D. Carpenter
Legislative Fiscal Officer
Legislative Fiscal Office

POTPOURRI

Department of Natural Resources Office of the Secretary

Fishermen's Gear Compensation Fund

In accordance with the provisions of R.S. 56:700.1 et seq., notice is given that 3 claims in the amount of \$10,331.92 were received for payment during the period September 1, 2012-September 30, 2012.

There were 3 paid and 0 denied.

Latitude/longitude coordinates, in degree decimal minutes, of reported underwater obstructions are:

29 09.390	90 39.200	Terrebonne
29 13.722	89 58.679	Jefferson
29 17.921	89 48.390	Plaquemines

A list of claimants and amounts paid can be obtained from Gwendolyn Thomas, Administrator, Fishermen's Gear Compensation Fund, P.O. Box 44277, Baton Rouge, LA 70804 or you can call (225) 342-9388.

Stephen Chustz
Interim Secretary

1210#028

POTPOURRI

Department of Public Safety and Corrections Oil Spill Corrdinator's Office

Request for Comments—Deepwater Horizon
Oil Spill—Draft Phase II Early Restoration
Plan and Environmental Assessment

Action:

Notice of availability; request for comments.

Summary:

In accordance with the Oil Pollution Act of 1990 (OPA), the Louisiana Oil Spill Prevention and Response Act (OSPRA), the National Environmental Policy Act (NEPA), and the framework agreement for early restoration addressing injuries resulting from the Deepwater Horizon oil spill (framework agreement), the federal and state natural resource trustee agencies (trustees) are preparing a draft early restoration plan and environmental assessment (DERP/EA) proposing early restoration projects intended to continue the process of restoring natural resources and services injured or lost as a result of the Deepwater Horizon oil spill, which occurred on or about April 20, 2010, in the Gulf of Mexico. The trustees previously released to the public a Draft Phase I Early Restoration Plan and Environmental Assessment in December 2011, which was approved as final in February 2012. The purpose of this notice is to inform the public of the availability of a Phase II DERP/EA, with an anticipated release date on or about October 30, 2012, and to seek written comments on the proposed restoration alternative presented in the Phase II DERP/EA.

Dates:

Comments Due Date. Public comments received on or before November 30, 2012 (or 30 days from the availability of the Phase II DERP/EA) will be considered.

Public Meeting. A public meeting will be scheduled to facilitate public review and comment on the Phase II DERP/EA. Both written and verbal public comments will be taken at the meeting. Details regarding meeting information will be published in local newspapers and will be posted on the web at <http://losco-dwh.com/>.

Addresses:

Obtaining Documents. You may download the Phase II DERP/EA once available, which is expected to be on or about October 30, 2012, at <http://losco-dwh.com/>. Please visit <http://losco-dwh.com/> for updates on the availability of the Phase II DERP/EA.

Alternatively, you may request a CD of the Phase II DERP/EA (see for further information contact). You may also review hard copies of the Phase II DERP/EA at the public repositories listed at <http://losco-dwh.com/>.

Submitting Comments. You may submit comments on the Phase II DERP/EA by one of the methods listed in the Phase II DERP/EA or any of the following:

- via the web: <http://losco-dwh.com/EarlyRestorationPlanning.aspx>;
- for electronic submission of comments containing attachments, email: Karolien.Debusschere@la.gov;
- U.S. Mail: Louisiana Oil Spill Coordinator's Office, P.O. Box 66614, Baton Rouge, LA 70806 or U.S. Fish and Wildlife Service, P.O. Box 2099, Fairhope, AL 36533.

For further information contact Karolien Debusschere at Karolien.Debusschere@la.gov.

Supplementary Information:

Introduction. On or about April 20, 2010, the mobile offshore drilling unit Deepwater Horizon, which was being used to drill a well for BP Exploration and Production, Inc. (BP) in the Macondo prospect (Mississippi Canyon 252-MC252), experienced a significant explosion, fire and subsequent sinking in the Gulf of Mexico, resulting in discharges of oil and other substances from the rig and from the wellhead on the seabed. An estimated 4.9 million barrels (210 million gallons) of oil were released from the well into the Gulf of Mexico over a period of approximately three months. In addition, an estimated 1.84 million gallons of dispersants were applied to the waters of the spill area in an attempt to minimize impacts from spilled oil. Affected resources include ecologically, recreationally, and commercially important species and their habitats in the Gulf of Mexico and along the coastal areas of Alabama, Florida, Louisiana, Mississippi, and Texas.

Federal and state trustees (listed below) are conducting the natural resource damage assessment for the Deepwater Horizon oil spill under the Oil Pollution Act 1990 (OPA; 33 U.S.C. §2701 et seq.). Pursuant to OPA, federal and state agencies and Indian tribes may act as trustees on behalf of the public to assess natural resource injuries and losses and to determine the damages required to compensate the public for those injuries and losses. OPA further instructs

the designated trustees to develop and implement a plan for the restoration, rehabilitation, replacement, or acquisition of the equivalent of the injured natural resources under their trusteeship.

The trustees are:

- U.S. Department of the Interior (DOI), as represented by the National Park Service, U.S. Fish and Wildlife Service, and Bureau of Land Management;
- National Oceanic and Atmospheric Administration (NOAA), on behalf of the U.S. Department of Commerce;
- State of Louisiana Coastal Protection and Restoration Authority, Oil Spill Coordinator's Office, Department of Environmental Quality, Department of Wildlife and Fisheries and Department of Natural Resources;
- State of Mississippi Department of Environmental Quality;
- State of Alabama Department of Conservation and Natural Resources and Geological Survey of Alabama;
- State of Florida Department of Environmental Protection and Fish and Wildlife Conservation Commission; and
- Texas Parks and Wildlife Department, Texas General Land Office and Texas Commission on Environmental Quality.

The U.S. Department of Defense (DOD), the Environmental Protection Agency (EPA) and the United States Department of Agriculture (USDA) are trustees but, to date, have not become signatories of the framework agreement.

Background:

On April 20, 2011, BP agreed to provide up to \$1 billion toward early restoration projects in the Gulf of Mexico to address injuries to natural resources caused by the Deepwater Horizon oil spill. This early restoration agreement, entitled *Framework for Early Restoration Addressing Injuries Resulting from the Deepwater Horizon Oil Spill* (framework agreement), represents a preliminary step toward the restoration of injured natural resources. The framework agreement is intended to expedite the start of restoration in the Gulf in advance of the completion of the injury assessment process. The framework agreement provides a mechanism through which the trustees and BP can work together to commence implementation of early restoration projects that will provide meaningful benefits to accelerate restoration in the Gulf as quickly as practicable prior to the completion of the natural resource damage assessment process or full resolution of the trustees' natural resource damages claim.

The trustees have actively solicited public input on restoration project ideas through a variety of mechanisms, including public meetings, electronic communication, and creation of a trustee-wide public website and database to share information and receive public project submissions. The trustees are considering a broad array of potential early restoration projects. Their key objective in pursuing early restoration is to secure tangible recovery of natural resources

and natural resource services for the public's benefit while the longer-term process of fully assessing injury and damages is still underway. In addition to the initial eight projects proposed in December 2011, the trustees are proposing additional projects, which will be set forth in the Phase II DERP/EA, in accordance with OPA and NEPA. The projects proposed in this plan are not intended to, and do not fully, address all injuries caused by the spill or provide the extent of restoration needed to satisfy claims against BP.

In keeping with the framework agreement, the Phase II DERP/EA will include an estimate of benefits anticipated to result from each project, referred to as "natural resource damage offsets" (NRD offsets). If these projects are approved, at the end of the NRDA process, the trustees would credit the NRD offsets generated by these early restoration projects towards the total restoration credits required based on the completed injury assessment. Further comprehensive restoration will still be required to fully compensate the public for natural resource losses from the oil spill.

Next Step:

After the public comment period ends, the trustees will analyze and address the comments and consider all input received before a phase II early restoration plan is finalized. As described above, a public meeting will be scheduled to facilitate the public review and comment process. Upon completion of the Phase II Early Restoration Plan, agreement with BP regarding these projects will be finalized and approved projects will proceed to implementation, pending compliance with all applicable state and federal laws.

Public Availability of Comments:

Before including your address, phone number, e-mail address, or other personal identifying information in your comment, you should be aware that your entire comment including your personal identifying information, may be publicly available at any time. While you can ask us in your comment to withhold your personal identifying information from public review, we cannot guarantee that we will be able to do so.

Administrative Record:

The documents comprising the Administrative Record can be viewed electronically at the following location: <http://losco-dwh.com/AdminRecord.aspx>.

Authority:

The authority of this action is the Oil Pollution Act of 1990 (33 U.S.C. §2701 et seq.), the implementing Natural Resource Damage Assessment regulations found at 15 CFR Part 990, the Louisiana Oil Spill Prevention and Response Act (La. R.S. §§30:2451-2496 (2010)), the implementing Natural Resource Damage Assessment regulations found at LAC 43:XXIX.101 et seq., and the framework agreement for addressing injuries resulting from the Deepwater Horizon oil spill.

Brian Wynne
Coordinator

1210#105

CUMULATIVE INDEX
(Volume 38, Number 10)

2012	
Pages	Issue
1-269.....	January
270-692.....	February
693-915.....	March
916-1147.....	April
1148-1343.....	May
1344-1473.....	June
1474-1879.....	July
1880-2301.....	August
2302-2450.....	September
2451-2682.....	October

EO—Executive Order
PPM—Policy and Procedure Memoranda
ER—Emergency Rule
R—Rule
N—Notice of Intent
CR—Committee Report
GR—Governor's Report
L—Legislation
P—Potpourri

ADMINISTRATIVE CODE UPDATE

Cumulative

- January 2011-December 2011, 261
- January 2012-March 2012, 1135
- January 2012-July 2012, 1870
- January 2012-September 2012, 2664

AGRICULTURE AND FORESTRY

Advisory Commission on Pesticides

- Pesticide restrictions, 1295N
- Restrictions on applications of certain pesticides, 1566R

Agriculture and Environmental Sciences

- Definition for the advisory commission on pesticides, 2569N
- Pesticide restrictions, giant salvinia
Lake Bistineau, 693ER
Toledo Bend, 694ER
- Quarantine listing for 2012, 1137P
- Seed inspection fees, 1039N, 1557R

Office of Agro-Consumer Services

- Suspension of rules governing the sale of gasoline with greater than 7.8 reid vapor pressure, 2311ER
- Suspension of rules governing the sale of gasoline with greater than 7.8 reid vapor pressure—amended, 2312ER

Animal Health, Board of

- Chronic wasting disease, 158N, 961R

Commissioner, Office of the

- Railroad crossings, 160N, 962R

Feed, Fertilizer and Agricultural Liming Commission

- Feed, fertilizer, and agricultural liming, 1749N, 2521R

Horticulture Commission

- Landscape architect registration exam, 265P, 678P, 2439P, 2667P

Seed Commission

- Seed inspection fees, 1039N, 1557R

Structural Pest Control Commission

- Minimum specifications for bait and baiting requirements, 2311ER
- Minimum specifications for trench and treat termite control work, 2453ER
- Wood destroying insect report and requests for rule changes or declaratory rulings, 2453ER

**AMITE RIVER BASIN DRAINAGE AND WATER
CONSERVATION DISTRICT**

- Expropriation of property, 1383R

**ASSESSORS' RETIREMENT FUND
BOARD OF TRUSTEES**

- Assessors' retirement fund, 2570N

CHILDREN AND FAMILY SERVICES

(Formerly Department of Social Services)

Division of Programs

- Block grant intended use report, 1139P
- Child care assistance program (CCAP) reducing the income limit for eligibility, 1883ER, 2386N
- Progress and services report, 1138P
- TANF caseload reduction, 678P

Economic Stability and Self-Sufficiency

- Child welfare emergency assistance services program, 2313ER, 2577N
- Elderly and disabled resource limit increase, 4ER, 350R
- KCSP grant reduction and termination of post-FITAP transitional services, 695ER, 838N, 1390R
- TANF initiatives, 272ER, 1040N, 1558R
- Verbal fair hearing withdrawals, 162N, 964R

Licensing Section

- Child safety alarm, 436N, 1207R
- Criminal record check, 166N
 - Sex offender prohibitions and state central registry disclosure, 272ER, 968R
- Emergency preparedness and evacuation planning, 4ER, 981R
- Foster care/substitute family care, 2003N
- Juvenile detention facilities, 285ER, 1041N, 1148ER, 1558R, 1884ER, 2388N
- Penalty for the operation of an unlicensed, 2575N
- Service delivery model monitoring and review, 984R

Secretary, Office of the

- Community and family support system
Flexible family fund, 2339ER

CIVIL SERVICE

Administrative Law, Division of

Administrative law, 1756N

Ethics, Board of

Ethics training, third party, 439N, 1209R
Food and drink limit, 1297N, 1951R
Late filings, 437N, 1207R

CULTURE, RECREATION AND TOURISM

State Library, Office of

Cultural resources, 2578N

ECONOMIC DEVELOPMENT

Louisiana Economic Development Corporation

Economic development award program (EDAP),
Economic development loan program (EDLOP), and
Economic development site readiness program
(EDRED), 1488ER, 1760N, 2528R

Secretary, Office of

Louisiana seed capital program (LSCP) and seed capital
program for the state small business credit initiative
(SSBCI), 734R, 986R

Research and development tax credit program, 350R

Small entrepreneurship certification program, 2012N

Small business loan and guaranty program (SBL and
GP) and state small business credit initiative (SSBCI)
program, 740R, 992R

The veteran initiative—certification, 2013N

Business Development, Office of

Competitive projects payroll incentive program,
2006N

Corporate headquarters relocation program, 2007N

Corporate tax apportionment program, 2009N

Economic development award program (EDAP),
Economic development loan program (EDLOP),
and Economic development site readiness program
(EDRED), 1488ER, 1760N, 2528R

Quality jobs program, 1488ER, 2011N

EDUCATION

Elementary and Secondary Education, Board of

Advisory councils, 772R

Technical revisions and updates, 2066N

Bulletin 111—The Louisiana School, District, and State
Accountability System, 443N, 839N, 1212R,
1391R, 1420N, 2014N, 2357R

Bulletin 118—Statewide Assessment Standards and
Practices, 33R, 747R, 2584N

Administrative error, 1421N, 2358R

Bulletin 119—Louisiana School Transportation
Specifications and Procedures, 748R, 2590N

Bulletin 126—Charter Schools, 184N, 1392R, 1583R
Virtual schools, 37R, 750R, 2027N
Application process, 2592N

Bulletin 129—The Recovery School District, 352R,
2594N

Parent petitions, 2031N

Return of schools to LEA, 841N, 1396R

Type 5 charter school, 1422N, 2358R

Bulletin 130—Regulations for the Evaluation and
Assessment of School Personnel, 445N, 1214R,
1424N, 2034N, 2359R

Bulletin 132—Louisiana Course Choice Program,
2035N

Bulletin 133—Scholarship Programs, 2041N, 2389N,
2667P

Bulletin 741—Louisiana Handbook for School
Administrators, 754R

Adult education programs, 844N, 1398R

Advanced placement and international baccalaureate,
1429N, 2363R

Approval for alternative schools or programs, 1066N,
1583R

Assessment, 455N, 1223R

Carnegie credit for middle school students, 2046N

Certification of personnel, 456N, 1224R

College and career diploma and career diploma, 761R

Compulsory attendance, 188N, 845N, 1000R, 1399R

Connections process, 189N, 1000R, 2047N

Credit recovery, 2048N

Curriculum and instruction, 190N, 1001R, 1067N,
1584R

Distance education, 2048N

Educational leader, 39R

Foreign languages, 1430N, 2364R

General career and technical education, 2049N

Physical education, 40R

Scheduling and student services, 457N, 1224R

School food service, 2051N

Sexual offenses affecting minors, 41R

Technology education, 847N, 1399R, 1431N, 2364R

Textbooks, 1432N, 2365R

Bulletin 741 (Nonpublic)—Louisiana Handbook for
Nonpublic School Administrators, 769R, 855N,
1008R, 1404R

Health and safety rules, three-year-old programs,
458N, 1226R

Bulletin 746—Louisiana Standards for State
Certification of School Personnel

Artist or talented certificate, 762R

Counselor K-12, 848N, 1400R

Criminal offenses, 762R

CTTIE-1 and CTTIE-2 certificates, 1433N, 2365R

Educational leader, 42R

Practitioner (residency) program, 765R

Educational technology areas, 766R

Instructional coaching, 767R

Requirements to add early childhood, 43R

Requirements to add elementary, 44R

School nurse, 44R, 1434N, 2366R

Social worker, 45R

Special education examiners, 768R

Standard teaching authorizations, 1297N, 1951R

Type C certificates, 2052N

EDUCATION (continued)

Bulletin 921—Policy and Procedure Manual for the Louisiana Quality Education Support Fund 8(g), 2058N
Bulletin 1196—Louisiana Food and Nutrition Programs, Policies of Operation, 2065N
Bulletin 1706—Regulations for Implementation of the Children with Exceptionalities Act, 1435N, 2367R
Expenditures, 850N, 1401R
Students with disabilities, 768R, 852N, 1006R, 1070N, 1225R, 1403R
Minimum foundation program, 854N, 1404R

Regents, Board of

Academic program standards, 461N, 1228R
Registration and licensure, 2595N

Student Financial Assistance Commission

Student Financial Assistance, Office of

Scholarship/Grant Programs, 200N, 309ER, 1884ER
Academic year, 2074N
Award amount, 354R
Definitions, 924ER
Establishing eligibility, 2455ER
TOPS cumulative high school grade point average, 2313ER, 2596N
Early start program, statewide general education course articulation matrix and approved LAICU institutions, 1229R
Establishing eligibility, 354R
GO grant, 924ER
J.R. Justice awards, 462N, 1585R
Nontraditional students, 1071N, 1953R
Summer sessions, 1072N, 1953R

Tuition Trust Authority

Student Financial Assistance, Office of

START savings program, 925ER, 1073N, 1890ER
Applicable definitions, 2080N
Interest Rates for 2010 and 2011, 1954R

ENVIRONMENTAL QUALITY

Environmental Compliance, Office of

Underground Storage Tank and Remediation Division

Application of groundwater protection fees at various sites in the state, 1850P

Environmental Services, Office of

Air Permits Division

Standard performance testing requirements, 1462P
Standard performance testing requirements sources not subjected to promulgated federal or state performance testing regulations, 1850P

Secretary, Office of

Federal air quality regulations, incorporation by reference, 2011, 463N, 1229R
Nonattainment new source review, 200N, 1231R
Offset requirements, 1172ER
Offset requirements and emission reduction credits banking, 1891ER, 2081N
Permit review, 1586R, 1954R

PM_{2.5} increments, significant impact levels and significant monitoring concentration, 857N
Public hearing—substantive changes—PM_{2.5} increments, significant impact levels and significant monitoring concentration, 2439P
Regulatory permit for rock, concrete, and asphalt crushing facilities, 1955R
State implementation plan (SIP)
GHG tailoring, 678P
Miscellaneous, 678P
Permit, 2008-2010, 678P
VOC, 678P

Legal Affairs Division

Addition to list of exempted compounds, 2084N
Comprehensive toxic air pollutant emission control program, 1762N
Discharges of produced water to the territorial seas, 265P
Emission comparable fuel exclusion withdrawal, 790R
EPA notice, 1765N
Exemptions from licensing, general licenses and distribution of byproduct material: licensing and reporting requirements, 1767N
Hazardous waste technical corrections and clarifications, 774R
Incorporation by reference update, 2085N
Medical use of byproduct material—authorized user clarification, 2088N
Minor revisions to water quality standards antidegradation language, 1768N
Notice of public hearing substantive changes to proposed rule OS083 stay of permit conditions pending administrative/judicial review, 1581P
Occupational dose records, labeling containers and the total effective dose equivalent, 1770N
OECD requirements, spent lead-acid battery exports, 781R, 1009R
Office of environmental assessment references, 1771N
Offset requirements, 7ER
Recyclable material removal from non-processing transfer station, 46R
Regulatory permit for flaring of materials other than natural gas, 2392N
Stay of permit conditions pending administrative/judicial review, 202N
Toxic emissions reporting requirements, 2086N
Waste expedited permitting process, 204N, 1232R

EXECUTIVE ORDERS

BJ 11-25 Executive Branch—Expenditure Reduction, 1EO
BJ 11-26 Qualified Energy Conservation Bond Allocation Louisiana Department of Public Safety and Corrections—Corrections Services, 2EO
BJ 11-27 Executive Branch—DOTD Guidelines for Vehicles, Trucks and Loads which Haul Hay from Louisiana to Texas, 3EO

EXECUTIVE ORDERS (continued)

- BJ 12-01 Carry-Forward Bond Allocation 2011, 270EO
- BJ 12-02 Rules and Policies on Leave for Unclassified Service—Amended Retroactive to January 14, 2008, 916EO
- BJ 12-03 Executive Branch—Expenditure Freeze, 921 EO
- BJ 12-04 Offender Labor, 923EO
- BJ 12-05 Coordinated Retirement Plan Sponsor—IRS Submission, 1474EO
- BJ 12-06 Executive Branch—Limited Hiring Freeze, 1880 EO
- BJ 12-07 DOTD Guidelines for Vehicles, Trucks and Loads Which Haul Hay from Louisiana to Texas, 1881 EO
- BJ 12-08 Flags at Half Staff, 2302 EO
- BJ 12-09 Boards and Commissioner per Diem Freeze, 2302EO
- BJ 12-10 DOTD Guidelines for Vehicles, Trucks, and Loads, 2303EO
- BJ 12-11 Declaration of Public Health Emergency and Temporary Suspend Licensure Requirements for Emergency Medical Technicians, 2304EO
- BJ 12-12 Licensed Bed Capacity for Nursing Homes, 2304EO
- BJ 12-13 Use of State Vehicles to Transport Non-State Employees during Emergency, 2305EO
- BJ 12-14 Emergency Procedures for Conducting State Business, 2306EO
- BJ 12-15 Hurricane Isaac Escort Requirements for Oversize Vehicles, Trucks and Loads, 2306EO
- BJ 12-16 Limited Transfer of Authority to Commissioner of Insurance for Emergency Rules for Hurricane Isaac, 2306EO
- BJ 12-17 Emergency Occupation of Hotels and Motels by Utility Restoration Personnel, 2308EO
- BJ 12-18 Public Health Emergency, 2309EO
- BJ 12-19 In Memoriam, 2309EO
- BJ 12-20 Moratorium on Boards and Commissions Authority to Pay per Diems and Elimination of Certain Boards, 2451EO
- BJ 12-21 Vehicle Expenditure Freeze, 2452 EO

FIREFIGHTERS PENSION AND RELIEF FUND
Firefighters Pension and Relief Fund, Board of Trustees

- Direct rollovers, 205N, 1011R
- Qualified domestic relations orders, 796R
- Tax qualification provisions, 207N, 1012R

GOVERNOR

- Administration, Division of**
 - Facility Planning and Control, Office of**
 - Capital improvement projects—Louisiana building code, 2597N
 - Information Technology, Office of**
 - OIT bulletin, 265P, 2291P

Patient's Compensation Fund Oversight Board

- Hurricane Isaac Emergency Provisions—Emergency Rule 4—Qualified Health Care Provider Services; Termination, Survival; Severability, 2314ER
- Patient's compensation fund, 1789N, 2533R

Property Assistance Agency

- Luxury vehicles, 1081N, 1588R

Racing Commission

- Daily doubles, 925ER, 1172ER, 1407R
- Field less than five, 1440N, 2548R
- Mandatory health screening, 926ER, 1174ER, 1407R
- Nonsteroidal and/or anti-inflammatory medication, 1408R
- Owner's entry of more than one horse, 2092N
- Pick five, 928ER, 1175ER, 1408R
- Superfecta, 1440N, 2549R
- Super six, 926ER, 1176ER
- Training tracks, 1018R

State Purchasing, Office of

- Reverse auctions, 859N, 1406R

State Travel, Office of

- General Travel—PPM 49, 1475PPM

State Uniform Payroll, Office of

- Payroll deduction, 47ER, 797R

Tax Commission

- Ad valorem taxation, 799R

Architectural Examiners, Board of

- Administration, place of seal or stamp, 208N, 1587R
- Continuing education, 1012R
- Internet advertising, 208N

Board of River Port Pilot Commissioners for the Port of New Orleans

- River port pilots, 1438N
- Steamship pilots for the Mississippi river, 2089N

Certified Shorthand Reporters, Board of Examiners

- Transcript certification, 1074N, 1957R

Financial Institutions, Office of

- Dishonest or unethical practices, 2093N
- Judicial interest rate determination for 2012, 265P

Governor's Report

- Governor's letter rejecting alternative fuel tax emergency rule, 1848GR

Home Inspectors, Board of

- Education, standards of practice, rehearing procedure, 1075N, 2529R
- Public hearing—substantive changes to proposed rule—continuing education hours; instructors, 1852P

Homeland Security and Emergency Preparedness

- Homeland security and emergency preparedness, 48R
- Intrastate mutual aid compact, 1019R

Law Enforcement and Administration of Criminal Justice, Commission on

- Federal funds distribution formula, 679P, 1080N, 1588R

Licensing Board for Contractors

- Contractors, 148R
- Home improvement registration and new home warranty act, 813R

Motor Vehicle Commission

- Recreational product manufacturer shows or events, 1344ER, 1441N

GOVERNOR (continued)

Oil Spill Coordinator's Office

Deepwater horizon oil spill, 1332P

Public Defender Board

Service restriction protocol, 813R

Real Estate Commission

Internet advertising, 1021R

Real estate schools, vendors, post-licensing and continuing education, 2393N

River Port Pilot Commissioners, Board of

River port pilots, 2369R

Tax Appeals, Board of

Procedure and practice before the board, 1787N

HEALTH AND HOSPITALS

Addictive Disorder Regulatory Authority

Addictive disorder regulatory authority, 209N

Disciplinary procedures, 1022R

Fees, 1025R

Aging and Adult Services, Office of

All inclusive care for the elderly, reimbursement rate reduction, 1493ER, 2459ER

CommunityCARE program termination, 1181ER

Community first choice option services, 1444N

Home and community-based services waivers

Adult day health care, reimbursement rate reduction, 1501ER, 1594R

Community choices waiver, 311ER, 1186ER, 1503ER

Standards for participation repeal, 314ER, 1368ER, 2469ER

Long term

Reimbursement rate reduction, 1527ER

Personal care services—long-term

Policy clarifications and service limit reduction, 325ER, 329ER, 1195ER, 2329ER

Reimbursement rate reduction, 2495ER

Behavioral Health, Office of

Behavioral health services, statewide management organization adults capitated payment reduction, 2461ER

Physical space requirements exemption

Standards for community mental health, 733ER, 1533ER, 2408N

Substance abuse/addictive disorders facilities minimum licensing standards, 732ER, 1534ER, 2407N

Substance abuse services, reimbursement rate reduction, 2501ER

Citizens with Developmental Disabilities, Office of

Home and community-based services waivers

Children's choice

Allocation of waiver opportunities, 933ER, 1900ER

Money follows the person rebalancing demonstration extension, 12ER, 1189ER

New opportunities waiver, reimbursement rate reduction, 1504ER

Service cap reduction, 1502ER

Residential options waiver, 934ER, 1505ER, 1900ER, 2469ER

Support coordination standards for participation, 1506ER, 1917ER

Supports waiver, reimbursement rate reduction, 1515ER, 2470ER

Dentistry, Board of

Anesthesia/Analgesia administration and continuing education requirements, 1300N, 1958R

Automated external defibrillator, 1805N

Continuing education requirements, 817R

Continuing education, licensure examinations and criminal history records, 2396N

Dentistry requirements, 355R

Examination of dentists, 1302N, 1959R

General provisions—evidence of graduation, restricted licensees, temporary licenses, and returning to active practice, 1806N

Licensure by credentials, 2397N

Patients' records, 1303N, 1960R

Restrictive license; fees, sedation, educational requirements, facilities and exceptions, 2400N

Embalmers and Funeral Directors, Board of

Embalmers and funeral directors, 466N

Public hearing, substantive changes to proposed rules; embalmers and funeral directors, 1140P

Emergency Response Network Board

LERN destination protocol: TRAUMA, 1333P, 1462P

Health Services Financing, Bureau of

Abortion facilities—licensing standards, 2457ER

Adult behavioral health services, 358R

Adult day health care

Minimum licensing standards, 695ER, 1490ER

Licensing standards, 1451N

Adult dentures program, reimbursement rate reduction, 1493ER, 2458ER

All inclusive care for the elderly, reimbursement rate reduction, 1493ER, 2459ER

Ambulatory surgical centers, reimbursement methodology, never events, 1181ER, 1304N, 1961R

Ambulatory surgical centers, reimbursement rate reduction, 1494ER, 2460ER

Behavioral health services, 360R

Behavioral health services, statewide management organization adults capitated payment reduction, 1495ER

Children's behavioral health services, 363R

Reimbursement rate reduction, 1495ER, 2461ER

CommunityCARE program

Redesign, 697ER

Termination, 1181ER, 1442N, 2370R

Community first choice option services, 1444N

Coordinated care network, 1893ER, 2598N

Direct service worker registry, 701ER, 1496ER

Disproportionate share hospital payments, 9ER, 1183ER, 2319ER

Distinct part psychiatric units, payment methodology, 310ER, 1185ER, 1895ER

Low income and needy care collaboration, 929ER, 1896ER

Small rural hospitals, qualifying criteria, 1898ER

Early and periodic screening, diagnosis and treatment

Dental program—reimbursement rate reduction, 1498ER, 2462ER

HEALTH AND HOSPITALS (continued)

Psychological and behavioral services and school based mental health services, 365R
School-based health centers, 931ER, 2321ER
School-based nursing services, 704ER, 1344ER, 2463ER
Substance abuse services, 706ER, 1347ER, 1449N, 2371R
Uncompensated care payments, 2600N
Electronic health records incentive payments inclusion of optometrists, 2322ER
End stage renal disease facilities, reimbursement rate reduction, 1499ER, 2465ER
Facility need review
Hospice providers, 707ER, 1087N, 1349ER, 1593R
Outpatient abortion facilities, 1305N, 1961R
Family planning clinics
Reimbursement methodology, office of public health uncompensated care payments, 2601N
Reimbursement rate reduction, 1500ER, 2466ER
Family planning waiver
Reimbursement rate reduction, 1501ER, 2467ER
Federally qualified health centers
Fluoride varnish applications, 11ER, 932ER, 1899ER
Greater New Orleans community health connection waiver, 820R
Home and community-based behavioral health services waiver, 366R
Home and community-based services providers
Minimum licensing standards, 63R
Minimum licensing standards, direct service worker exemption, 861N, 1410R
Home and community-based services waivers
Adult day health care, reimbursement rate reduction, 1501ER, 1594R, 2467ER
Children's choice
Allocation of waiver opportunities, 933ER, 1900ER
Money follows the person rebalancing demonstration extension, 12ER, 1189ER, 2322ER
Service cap reduction, 1502ER
Community choices waiver, 311ER, 1186ER, 1503ER, 2323ER, 2327ER
Cost reporting requirements, 1504ER, 2468ER
New opportunities waiver, reimbursement rate reduction, 1504ER, 1901ER
Repeal of standards for participation, 314ER, 1368ER, 2469ER
Residential options waiver, 934ER, 1505ER, 1900ER, 2469ER
Standards for participation, 2100N
Support coordination standards for participation, 708ER, 1506ER, 1917ER
Supports waiver, reimbursement rate reduction, 1515ER, 2470ER
Home health program, durable medical equipment reimbursement rate reduction, 1515ER, 2471ER
Nursing and home health aide services reimbursement rate reduction, 1516ER, 2472ER
Home health services, cost reporting requirements, 1517ER, 2472ER
Hospice services, 717ER, 1350ER, 2473ER
Hospital licensing standards

License renewal and dietary services, 862N, 1413R
Inpatient hospital services
Distinct part psychiatric units, reimbursement methodology, 315ER, 1190ER, 1925ER, 2602N
Free-standing psychiatric hospitals, low income and needy care collaboration, 949ER, 1926ER
Healthcare-acquired and provider preventable conditions, 1191ER, 1307N, 1962R
Major teaching hospitals
Qualifying criteria, 2477ER
Supplemental payments, 2476ER
Neonatal and pediatric intensive care units and outlier payment methodologies, 1927ER
Non-rural, non-state hospitals
Low income and needy care collaboration, 1930ER
Reimbursement rate reduction, 1931ER
Non-rural, non-state public hospitals
Reimbursement methodology, 1931ER, 2405N, 2479ER
Supplemental payments, 1932ER, 2101N
Pre-admission certification, 13ER, 824R
Reimbursement methodology, medical education payments, 321ER, 720ER, 1359ER, 2103N, 2480ER
Small rural hospitals
Low income and needy care collaboration, 13ER, 1192ER, 2327ER
Upper payment limit, 468N, 722ER, 1240R
State hospitals
Reimbursement rate reduction, 1933ER
Supplemental payments, 469N, 951ER, 1241R
Intermediate care facilities for persons with developmental disabilities
Minimum licensing standards, 864N
Non-state facilities, reimbursement methodology, 722ER, 1517ER
Public facilities reimbursement methodology, 14ER, 1193ER, 1934ER
Reimbursement rate reduction, 1518ER, 2481ER
Laboratory and radiology services, reimbursement rate reduction, 1519ER, 2482ER
Laboratory services, office of public health uncompensated care payments, 2604N
LaCHIP affordable plan
Dental program, reimbursement rate reduction, 1520ER, 2483ER
Licensing standards for adult day health care, 2372R
Major teaching hospitals
Qualifying criteria, 316ER, 1354ER
Supplemental payments, 318ER, 1356ER
Medical transportation program
Emergency ambulance services
Reimbursement rate reduction, 723ER, 1360ER, 1521ER, 1936ER, 2484ER
Supplemental payments, 2485ER
Non-Emergency medical transportation public transit services, 726ER, 1522ER, 2406N
Neonatal and pediatric intensive care units and outlier payment methodologies, 319ER, 1357ER
Non-rural, non-state hospitals
Low income and needy care collaboration, 950ER
Reimbursement methodology, 951ER

HEALTH AND HOSPITALS (continued)

Nursing facilities

Minimum licensing standards

Civil monetary penalty waivers, 824R

Nurse aide training and competency evaluation program, 1241R, 1410R

Per diem rate reduction, 470N, 1241R

Reimbursement methodology

Low income and needy care collaboration, 323ER, 1363ER, 2487ER

Reimbursement rate reduction, 1522ER, 1936ER

Reimbursement rate reduction, post-rebase rate cut, 2488ER

Reimbursement rate reduction pre-rebase rate cut, 1523ER, 1937ER, 1938ER, 2489ER

Minimum data set assessments, 16ER, 825R

Private room conversions, 324ER, 1364ER, 2490ER

Outpatient hospital services

Diabetes self-management training, 19ER, 1194ER, 2328ER

Never events, 1202ER, 1308N, 1963R

Small rural hospitals

Low income and needy care collaboration, 727ER, 1524ER

Upper payment limit, 472N, 729ER, 1251R

Non-rural, non-state public hospitals, supplemental payments, 2490ER

Non-rural, non-state hospitals and children's specialty hospitals, reimbursement rate reduction, 1939ER

State-owned hospitals, medical education payments, 324ER, 730ER, 1364ER, 2104N, 2492ER

Reimbursement rate reduction, 1940ER

Pediatric day health care program, reimbursement rate reduction, 1526ER, 2493ER

Personal care services, long-term

Cost reporting requirements, 1527ER, 2494ER

Policy clarifications and service limit reduction, 20ER, 325ER, 329ER, 1195ER, 2329ER

Reimbursement rate reduction, 1527ER, 2495ER

Pharmacy benefits management program

Maximum allowable costs, 24ER, 1199ER

Medication administration, influenza vaccinations, 952ER, 1941ER

Methods of payment, 2333ER, 2605N

Prescription time limits, 368R

Pregnant women extended services

Dental services, reimbursement rate reduction, 1529ER, 2495ER

Substance abuse screening and intervention services, 731ER, 1528ER

Professional services program

Anesthesia Services, reimbursement rate reduction, 1529ER, 1942ER, 2496ER

Diabetes self-management training, 25ER, 1201ER, 2336ER

Family Planning Services

Reimbursement rate reduction, 1530ER, 2497ER

Uncompensated care payments, 2608N

Fluoride varnish applications, 26ER, 953ER, 1943ER

Immunizations, uncompensated care payments, 2609N

Physician services

Reclassification of optometry services, 2337ER, 2498ER

Reimbursement rate reduction, 1531ER, 2499ER

Reimbursement methodology

Never events, 1202ER, 1309N, 1964R

Supplemental payments, 333ER, 1366ER

Supplemental payments for Tulane, professional practitioners, 1532ER

Prosthetics and orthotics, reimbursement rate reduction, 1533ER, 2500ER

Psychiatric residential treatment facilities, 369R

Minimum licensing standards, 371R, 1944ER

Public facilities, reimbursement methodology, 14ER

Professional services program supplemental payments for Tulane professional practitioners, 224N

Rural health clinics

Fluoride varnish applications, 27ER, 954ER, 1945ER

School based behavioral health services, 400R

Standards for community mental health, physical space requirements exemption, 733ER, 1533ER, 2408N

Substance abuse/addictive disorders facilities

Minimum licensing standards, physical space requirements exemption, 732ER, 2407N

Substance abuse and addiction treatment facilities, licensing standards, 473N

Substance abuse services, 426R, 1535ER

Reimbursement rate reduction, 2501ER

Surveillance and utilization review subsystem, 1535ER, 2106N

Targeted case management

Nurse family partnership program, uncompensated care payments, 2611N

Reimbursement rate reduction, 1549ER, 2502ER

Therapeutic group homes, 427R

Minimum licensing standards, 401R

Uncompensated care payments, 1550ER, 2502ER

Hearing Aid Dealers, Board for

Offices of the board, ethics and licenses, 1589R

Licensed Professional Counselors, Board of Examiners

Marriage and family licensure requirements, 1310N

Mental health counseling, 335ER, 1367ER

Requirements for licensure, 1965R

Licensed Professional Vocational Rehabilitation

Counselors, Board of Examiners

Practice of mental health counseling for serious mental illnesses, 2503ER

Medical Examiners, Board of

Clinical laboratory personnel, licensure and certification, 210N, 1026R

Licensure and certification; definitions; qualifications for license, 1808N, 2402N

Physician assistants, licensure and certification; qualifications for registration of prescriptive authority, 2403N

Physician assistants, practice, 1233R

Physician licensure and certification; reports to the board, 2404N

Respiratory therapists, licensure, certification and practice, 52R

HEALTH AND HOSPITALS (continued)

Nursing, Board of

- Denial or delay of licensure, 818R
- Procedure for establishing a new program, 1489ER, 1809N, 2549R

Nursing Facility Administrators, Board of Examiners

- Administrator-in-training (AIT) waiver, 51R

Optometry Examiners, Board of

- Licensing; dispensation of medication, 1082N, 1590R

Pharmacy, Board of

- Cognitive services, 212N, 1233R
- Controlled dangerous substance license for non-resident distributors, 1810N
- Controlled dangerous substances in emergency drug kits, 1811N
- Durable medical equipment permit, 1177ER, 2316ER
- E-communications, 213N, 1234R
- Hospital pharmacy, 213N, 1235R
- Institutional pharmacies, 1814N
- Interstate remote processing, 1813N
- Medical orders remote processing, 220N, 1240R
- Penal pharmacy, 215N, 1235R
- Pharmacist-in-charge, 216N, 1239R
- Prescription monitoring program, 1815N
- Security of prescription department, 1817N

Psychologists, Board of Examiners

- Continuing education, 2096N

Public Health, Office of

- Disease reporting requirements, 2121N
- Early and periodic screening, diagnosis and treatment
- Uncompensated care payments, 2600N
- Immunization requirements, 896N, 1252
- Professional services program
- Family planning services uncompensated care payments, 2608N
- Immunizations, uncompensated care payments, 2609N
- Public hearing—substantive changes to proposed rule amendments—accreditation of laboratories conducting drinking water analyses, 2667P
- Review and approval of plans and specifications for issuance of a permit for a potable water supply, 2504ER
- Targeted case management
- Nurse family partnership program, uncompensated care payments, 2611N
- Uncompensated care payments, 2502ER

Emergency Medical Services

- Automated external defibrillators, 2124N

Maternal and Child Health Section

- MCH block grant, 1464P

Nutrition Services Program

- Special supplemental nutrition program for women, infants and children (WIC), 2291N

Sanitary Code

- General provisions and water supplies, 2374R
- Marine and fresh water animal food products, 95R, 2127N
- Plumbing, 2129N
- Shellstock, interstate commerce, 1369ER

Tuberculosis Control Program

- Required medical examinations, 2265N

Radiologic Technology, Board of Examiners

- Fusion technology, 97R

Secretary, Office of the

- Community and family support system
- Flexible family fund, 2339ER

Veterinary Medicine, Board of

- Alternative therapy and collaborative treatment, preceptorship program, and certified animal euthanasia technician, 356R
- Fall/Winter examination dates, 1853P
- Licensure procedures, continuing veterinary education, fees, 1083N, 1591R

Wholesale Drug Distributors, Board of

- Fees, 1086N, 1960R
- Policy and procedures and quarantine of legend drugs or legend devices, 2099N

INSURANCE

Commissioner, Office of

- Emergency Rule 26—suspension of certain statutes and regulations regarding cancellations, non-renewals, reinstatements, premium payments, claim filings and related provisions regarding any and all insurance matters affecting insureds in Louisiana caused by hurricane Isaac, 2341ER
- Regulation Number 100—coverage of prescription drugs through a drug formulary, 225N, 1027R
- Emergency Rule 26—suspension of certain statutes and regulations regarding cancellations, non-renewals, reinstatements, premium payments, claim filings and related provisions regarding any and all insurance matters affecting insureds in Louisiana caused by hurricane Isaac—amended, 2347ER

Health, Office of

- Annual HIPAA assessment rate, 1464P

LEGISLATION

Concurrent Resolutions

Senate

- No. 107, sexual harassment training, 1459L

House

- No. 6, exemption inclusion of the Zoo of Acadiana, 1459L
- No. 16, acquisition of property for the Comite Diversion Canal Project, 1460L
- No. 69, limitations on examinations of applicant for certification as an athletic trainer, 1460L, 1849L

Senate Committee on Commerce

- Report of Senate Committee Emergency Rule Oversight
- Hearing on LAC 35:I:1505, 677CR

LOUISIANA ECONOMIC DEVELOPMENT CORPORATION

- Louisiana Seed Capital Program (LSCP) and Seed Capital Program for the State Small Business Credit Initiative (SSBCI), 734R, 986R
- Small Business Loan and Guaranty Program (SBL and GP) and State Small Business Credit Initiative (SSBCI) Program, 740R, 992R

NATURAL RESOURCES

Coastal Management, Office of Interagency Affairs/Field Services Division

Review of federal financial assistance—awards for consistency with the Louisiana coastal resources program, 2439P

Conservation, Office of

Advanced notice of proposed rulemaking and solicitation of comments, 1853N

Amendment to statewide orders no. 29-B and 29-B-a, 336ER

Definitions, 1414R

Fees, 2267N

Hazardous liquids pipeline safety, 99R

Hearing, docket no. ENV 2012-04, 1334P

Legal notice, docket no. ENV 2012-05, 1868P

Legal notice, docket no. ENV 2012-L01, 679P

Legal notice, docket no. ENV 2012-L-002

Natural gas pipeline safety, 110R, 828R

Notification and confirmation of new water well construction, 1818N

Orphaned oilfield sites, 679P, 1335P, 1465P, 1869P, 2291P, 2440P

Statewide orders no. 29-B and 29-B-a

Deadline of drilling and completion operational and safety requirements for wells drilled in search or for the production of oil or natural gas at water locations, 2905ER

Operational and safety requirements for wells drilled in search or for the production of oil or natural gas at water location, 1370ER

Environmental Division

Advanced notice of rulemaking and solicitation of comments on water well notification and construction, 1140P

Legal notice—docket no. ENV 2012-07, 2291P

Mineral Resources, Office of

Mineral resources, alternative energy leasing and dry hole credit, 125R

Secretary, Office of the

Fishermen's Gear Compensation Fund

Reported underwater obstructions, latitude/longitude coordinates, 266P, 680P, 910P, 1141P, 1336P, 1464P, 1869P, 2440P, 2670P

PUBLIC SAFETY AND CORRECTIONS

Corrections Services

Judicial agency referral residential facilities, 2269N

Louisiana risk review panel, 2271N

Louisiana sex offender assessment panels, 429R

Offender incentive pay and other wage compensation, 511N, 1252R

Offender mail and publications, 830R

Offender visitation, 835R

Performance grid and administrative sanctions, 955ER, 1090N, 1597

Sex offender payment for electronic monitoring, 432R

Sex offender treatment plans and programs, 1092N, 1599R

Gaming Control Board

Electronic submission of documents, 2271N

Gaming, regulation consolidation, 513N, 1601

Record preparation fees, 2274N

Liquefied Petroleum Gas Commission

Liquefied petroleum gas, 228N, 1254R

Motor Vehicles, Office of

Driver education, 2352ER, 2409N

Driver's license, 1094N, 1974R

Veterans driver's license, 2624N

Oil Spill Coordinator's Office

Request for comments—deepwater horizon oil spill—draft phase II early restoration plan and environmental assessment, 2670P

Pardons, Board of

Committee on Parole

Membership, duties, and functions, 2613N

Private Investigator Examiners, Board of

Continuing education, 898N, 1088N, 1596R, 2378R

State Fire Marshal, Office of

Manufactured housing, 2411n

State Police, Office of

Issuance of concealed handgun permits, 642N, 1279R, 1415R

Motor vehicle inspections, 1819N, 2550R

Operator qualifications, 2275N, 2562R

Public hearing—towing, recovery and storage, 266P

Special permit for vehicles hauling sugarcane, 2632N

Towing, recovery and storage, 1832N

Applied Technology Unit

Breath and blood alcohol analysis, 1113N, 1992R

Transportation and environmental safety section

Motor carrier safety revision date and weight, 899N, 1417R

State Uniform Construction Code Council

Building code enforcement officer, 957ER

Provisional certificate of registration deadline, 28ER

Seismic design and electrical code, 1115N, 1994R

Structural design for earthquake loads, 957ER

REVENUE

Alcohol and Tobacco Control, Office of

Good standing, 144R

Participation in hearing by video conference, 648N, 1285R

Regulation III, prohibitive acts, vending machines, 2276N

Regulation VII, procedures determined for issuing permits, 2277N

Regulation IX, prohibition of certain unfair business practices, 650N, 1286R, 2278N

Tobacco permits, 145R, 2280N

Policy Services Division

Alternative fuel credit, 1203ER, 2420N

Certain self-propelled vehicles removed from inventory, 1320N, 1995R

Corporation income and franchise tax filing extensions, 958ER, 2625N

Electronic funds transfer, 347ER, 1321N, 2382R

REVENUE (continued)

Income—withholding tax, 2627N
Income and franchise tax, 2626N
Income tax credits for wind or solar energy systems,
2282N, 2416N
Individual income tax filing extensions, 959ER, 2628N
Natural gas severance tax rate, effective July 1, 2012,
1336P
Payment of sales and use taxes by persons constructing,
altering, or repairing immovable property, 1116N,
1995R
Withholding tax statements and returns electronic filing
requirements, 347ER, 1322N, 2382R

DEPARTMENT OF STATE

Elections Division

Emergency election day paper ballot procedures,
2516ER

TRANSPORTATION AND DEVELOPMENT

Aviation, Office of

Aviation program needs and project priority process,
1118N

Highways/Engineering, Office of

Design-build pilot program repeal, 2629N

Multimodal Planning, Office of

Port design-build pilot program, 2631N

Operations, Office of

Special permit for vehicles hauling sugarcane, 2519ER,
2632N

Professional Engineering and Land Surveying Board

Definitions, 835R, 1029R
Examinations and experience, 1835N, 2563R
Supervising professionals and use of seals, 900N,
1418R

Transportation Authority

Toll appeal procedure—LA 1, 2379R
Toll exemptions—LA 1, 2380R

TREASURY

Louisiana Housing Corporation

Turnkey mortgage origination program, 1996R

Louisiana State Employees' Retirement System, Board of Trustees

Election to the board of trustees, 2633
Internal revenue code provisions, 902N, 1324N
Plan year; limitations year, 2635N
Procedures for processing disability applications, 836R

Registrars of Voters Employees' Retirement System

Retirement system trustees election procedures, 1029R

Treasurer, Office of

Permissible investments, 146R

VETERANS AFFAIRS

Veterans Affairs Commission

Veterans affairs, 253N, 1015R

WILDLIFE AND FISHERIES

Wildlife and Fisheries Commission

2011 fall inshore shrimp season closure, 28ER, 248ER
2012 fall shrimp season opening, 1946ER
2012 gag grouper bag season, 959ER
2012 greater amberjack season closure, 960ER
2012 large coastal shark commercial season closure,
1551ER
2012 oyster season on public oyster seed grounds,
1947ER, 2354ER
2012 red snapper recreational fishery extension,
1552ER
2012-2013 commercial king mackerel season, 29ER
2012-2013 commercial king mackerel season closure,
2353ER
2012-13 Deer Season Rules and Regulations,
Adjustment, 2519ER
2012-2013 recreational reef fish seasons, 29ER
2012-2013 reef fish commercial seasons, 30ER
2012-2013 waterfowl season dates, 1947ER
Additional spring inshore shrimp season closure,
1948ER
Calcasieu ship channel to the Louisiana/Texas state
line, 1552ER
Mississippi/Louisiana state line to Bayou Lafourche
and freshwater bayou canal to the Calcasieu ship
channel, 1553ER
Calcasieu lake oyster harvester permit, 1838N, 2567R
Charter boat fishing guides and operations—liability
insurance requirements, 2423N
Crappie regulations—daily take, 1840N
Early season migratory bird hunting regulations,
1553ER
East zone alligator season extension, 2520ER
Emergency oyster season closure
Sister Lake and Bay Junop public oyster seed
reservations, 30ER
Falconry, 2636N
False river, trammel and gill nets, 655N, 1732R
Feral hog trapping, 1131N, 1997R
Fisheries closure due to oil spill, 1949ER
Gag grouper recreational season closure, 31ER
General and wildlife management area hunting rules
and regulations, 656N, 1732R
General and WMA turkey hunting, 1840N
Gray triggerfish commercial season closure, 1554ER,
1555ER
Internet purchase of commercial licenses and permits,
2286N
Large coastal and small coastal shark commercial
season opening, 349ER
Oyster season closure, primary public oyster seed
grounds east of the Mississippi river, 349ER

WILDLIFE AND FISHERIES (continued)

Partial opening of shrimp season in state outside waters, 1205ER
Recreational and commercial fisheries closure, 31ER, 1205ER, 2355ER
Recreational offshore landing permit, 2424N
Reef fish, 1132N, 1454N, 1455N, 2383R, 2425N
Removal of abandoned crab traps, 146R, 2427N
Resident game hunting season, 671N, 1747R
Special bait dealer's permit, 2428N
Spring inshore shrimp season
 Closure in portions of state inside waters, 1555ER
 Opening dates, 1206ER
Temporary fall inshore shrimp season closure, 2355ER
Tuna harvest regulations, 1419R
Turkey hunting areas, season, and bag limits, 1843N
Triploid grass carp, 433R
Vessel monitoring systems; oyster seed ground vessel permit, 674N, 1997R
Wild alligator harvest season postponed, 2356ER

Wild seafood certification program, 651N, 1999R, 2566R

Yo-Yo and trotline regulations, 1845N, 2567R

WORKFORCE COMMISSION

Workers' Compensation Administration, Office of

Average weekly wage rate, 2292N
Community rehabilitation program, 147R
Electronic medical billing and payment companion guide, 2643N
Employer's report of injury/illness form LWC-WC-1A-1, 2431N
Form LWC-WC-1009, 2288N
Pharmaceutical billing, 836R
Public hearing for substantial changes to proposed rules, 680P
Utilization review procedures, 256N, 266P, 1030R, 1286R, 2433N
Weekly compensation benefits limits, 2292N