

Table of Contents

Title 31 ELECTIONS

Part I. Election Process

Chapter 1.	Polling Place Accessibility for the Elderly and Individuals with Disabilities	1
§101.	Definitions.....	1
§103.	Determination of Accessibility	1
§105.	Guidelines for Accessibility.....	1
§107.	Guidelines for Polling Places.....	6
§109.	Exemption Procedures	6
§111.	Repeal Prior Rules and Regulations.....	7
Chapter 3.	Opportunity to Cure Deficiencies in Absentee by Mail Ballots	7
§301.	Absentee by Mail Ballot Deficiencies that May Be Cured.....	7
§303.	Absentee Ballot Deficiency Notification	7
§305.	Curing Absentee by Mail Ballot Deficiencies	8
Chapter 5.	Election Night Transmission of Results.....	8
§501.	Responsibility of Secretary of State.....	8
§503.	Responsibility of Clerk of Court.....	8
§505.	Transmission of Election Night Returns.....	8
Chapter 7.	Election Expense Reimbursement	9
§701.	Department of State's Election Expense Manual	9
§703.	Clerk of Court Expenses	9
§705.	Registrar of Voters Expenses.....	9
§707.	Parish Board of Election Supervisors Expenses	9
§709.	Deadline for Submission of Expenses to Department of State	10
Chapter 8.	Voting Technology	10
Subchapter A.	Private Elections	10
§801.	Type of Election.....	10
§803.	Private Elections Manual	10
§805.	Department Election Expenses	11
Subchapter B.	Maps of Precincts and Election Jurisdictions	11
§809.	Maps of Precincts and Election Jurisdictions	11
Chapter 9.	Recognition of Political Parties.....	11
§901.	Purpose.....	11
§903.	Definitions.....	11
§905.	Political Party Recognition Based on Registered Voters.....	11
§907.	Defects in a Registration Statement.....	11
§909.	Objection to a Registration Statement	12
§911.	Notification	12
Chapter 11.	Emergency Election Day Paper Ballot Voting Procedures	12
§1101.	Emergency Declaration.....	12
§1103.	Preparation and Supplies for Implementation of Emergency Election Day Paper Ballot Voting Procedures.....	12
§1105.	Procedures for Voting and Termination of Voting for Paper Ballots	13
§1107.	Delivery of "Election Day Voted Paper Ballots" Envelope and Tabulation and Counting of Paper Ballots	14

Part II. Voter Registration

Chapter 1.	Registrars of Voters	15
§101.	ERIN Manual	15
§103.	Removal of Registrar of Voters for Cause.....	15
§105.	Sale of Voter Registration Lists	16
§107.	Merit Evaluation for the Registrar of Voters	17
§109.	Merit Evaluations of the Chief Deputy and Confidential Assistant	18
§111.	Professional Review Committee.....	18
§113.	Annual Expenditure Report to Parish Governing Authority.....	18
§115.	Repeal Prior Rules and Regulations.....	18
§117.	Prohibition on Accumulation of Annual, Sick and Compensatory Leave for Registrars of Voters	18
Chapter 2.	Registrars of Voters	19
§201.	Appeal of Merit Evaluation for the Registrar of Voters	19
Chapter 3.	Voter Registration at Driver's License Facilities	19
§301.	Objective	19
§303.	Secretary of State	20
§305.	Parish Registrars of Voters	20
§307.	Authorized Employees at Driver's License Facilities	20
§309.	Training.....	22
§311.	Review Process	22
Chapter 4.	Voter Registration at Mandatory Voter Registration Agencies in the State that Provide Public Assistance or Provide State-funded Programs Primarily Engaged in Providing Services to Persons with Disabilities	22
§401.	Objective	22
§403.	Definitions.....	22
§405.	Services Made Available	23
§407.	Declaration Form	23
§409.	Transmittal of Voter Registration Applications Accepted at Mandatory Voter Registration Agencies.....	24
§411.	Qualified Employees at Mandatory Voter Registration Agencies.....	24
§413.	Review Process	24
§415.	Training.....	25
§417.	List of Mandatory Voter Registration Agencies	25
§419.	Monitoring and Compliance	25
§421.	Application of this Chapter.....	25
Chapter 5.	Voter Registration at Optional Voter Registration Agencies	25
§501.	Objective	25
§503.	Designation of Optional Voter Registration Agencies	25
§505.	Implementation	26
Chapter 7.	Standards for Effective Non-Partisan Voter Registration and Voter Education.....	26
§701.	Department of State's Outreach Activities.....	26
§703.	Registrars of Voters	26
§705.	Annual Voter Registration Week.....	26
§707.	Funding for Outreach Efforts.....	27
§709.	Reporting Requirements	27

Part III. Procurement

Chapter 1. Procurement of Voting System Drayage and Storage	29
§101. Definition	29
§103. Revised Statutes	29
§105. Invitation for Drayage and Storage Bids, Public Notice, and Bid Opening	29
§107. Evaluation of Drayage and Storage Bids	30
§109. Responsibility of Drayage and Storage Bidders	30
§111. Correction of Withdrawal of Drayage and Storage Bids	30
§113. Drayage Bid Guaranty and Bond	30
§115. Drayage Performance Bond	30
§117. Forfeiture of Bonds for Drayage	31
§119. General Guaranty for Drayage	31
§121. Award of Drayage and Storage Contracts	31
§123. Rejection of Drayage or Storage Bids; Cancellation of Drayage or Storage Solicitations	31
§125. Emergency Drayage Procurements	32
§127. Collusive Bidding or Negotiations of Drayage or Storage Contracts	32
§129. Drayage and Storage Specifications	32
§131. Drayage Contract Requirements	32
§133. Right to Protest Drayage or Storage Contract Award	32
§135. Legal and Contractual Remedies for Drayage and Storage of Voting Systems	33
§137. Suspension and Debarment of Drayage or Storage Contractor	33
§139. Repeal Prior Rules and Regulations	33
Chapter 3. Procurement and Certification of Voting Equipment	33
Subchapter A. Competitive Sealed Bidding	33
§301. Invitation for Bids, Public Notice, and Bid Opening	33
§303. Certification of Voting Equipment	34

Title 31 ELECTIONS

Part I. Election Process

Chapter 1. Polling Place Accessibility for the Elderly and Individuals with Disabilities

§101. Definitions

A. For the purpose of this rule, the definitions detailed below shall apply.

Accessible Parking—a place specially designated by the International Symbol for Accessibility and other markings with dimensions as specified in LAC 31:I.105.A.1.a.i.

Accessible Polling Place—the combination of the various elements of the built environment that is free of physical barriers, as prescribed herein, which allows parking, entrance to, egress from, and use of polling place facilities by the elderly and individuals with disabilities for the purpose of voting.

Blend to a Common Level—the meeting of two or more surfaces free from abrupt level changes over 1/2 inch. Level changes between 1/4 and 1/2 inch must be beveled with a slope no greater than 1:2. Level changes up to 1/4 inch require no change.

Circulation Route—a continuous path of travel from the curb or parking area to the polling place building, into and through the polling place building to the voting area, and includes both horizontal and vertical travel.

Curb—the inside boundary of the street, driveway, or parking lot.

Elderly—any person who is 65 years of age or older.

Exterior Circulation Route—that part of a circulation route from the curb or parking area to the point of entry to the polling place building or facility.

Individual with Disabilities—any person who has a temporary or permanent physical disability.

Interior Circulation Route—that part of a circulation route from the point of entry to the polling place building through the polling place building to the voting area.

Passenger Loading Zone—a place specially provided outside of the vehicular traffic flow designed for the drop-off or pick-up of passengers from vehicles.

Temporarily Accessible—modifications or improvements that are not permanent to various elements of the existing built environment as prescribed herein which allow parking, entrance to, egress from, and use of polling place facilities by the elderly and individuals with disabilities for the purpose of voting and registration.

AUTHORITY NOTE: Promulgated in accordance with R.S. 18:533, R.S. 36:742, 42 U.S.C. §1973ee et seq., and Public Law 107-252.

HISTORICAL NOTE: Promulgated by the Department of State, Elections Division, LR 35:1257 (July 2009).

§103. Determination of Accessibility

A. It is the responsibility of the parish governing authority to select an accessible building or facility to be used as a polling place.

B. The parish governing authority shall visit each polling place to be used on election day and for early voting. The parish governing authority must complete an accessibility survey on an official form provided by the Department of State for every polling place building or facility to determine whether the polling place is accessible, temporarily accessible, or inaccessible based on the accessibility criteria set forth herein. At the end of the survey form, the parish governing authority shall certify that the polling place is accessible or has been made temporarily accessible prior to the use of the polling place for an election.

C. The original completed survey shall be filed with the Department of State. A copy of the survey shall be retained by the parish governing authority for the period the site is used as a polling place.

D. The Secretary of State or designee reserves the right to conduct on-site inspections of polling places.

E. If an existing polling place fails to satisfy the accessibility criteria set forth herein and cannot be temporarily modified in a reasonable manner, it shall be deemed inaccessible by the parish governing authority and shall not be used unless an exemption is granted by the secretary of state pursuant to §109 of this Chapter.

F. When a proclamation has been adopted to move a polling place, the parish governing authority shall provide the department with a completed accessibility survey form and certification that the new polling place location is accessible. The Secretary of State will not accept the polling place change without a completed accessibility survey and certification.

AUTHORITY NOTE: Promulgated in accordance with R.S. 18:533, R.S. 18:534, R.S. 18:535, R.S. 18:536, R.S. 36:742, 42 U.S.C. §1973ee et seq., and Public Law 107-252.

HISTORICAL NOTE: Promulgated by the Department of State, Election Division, LR 35:1258 (July 2009).

§105. Guidelines for Accessibility

A. To be accessible to the elderly and individuals with disabilities, the polling place must have at least one circulation route that encompasses an exterior circulation route, ramps, entrances, doors, doorways, an interior circulation route, and may include elevators which meet the following criteria.

ELECTIONS

1. Exterior Circulation Routes. There shall be at least one path of travel at least 36 inches wide within the boundary of the site that shall have no steps, abrupt changes or slopes greater than 1:12 from the public transportation stops, accessible parking areas, accessible passenger loading zones, and public streets and sidewalks to an accessible entrance of the polling place building or facility. The accessible route shall, to the maximum extent feasible, coincide with the route for the general public.

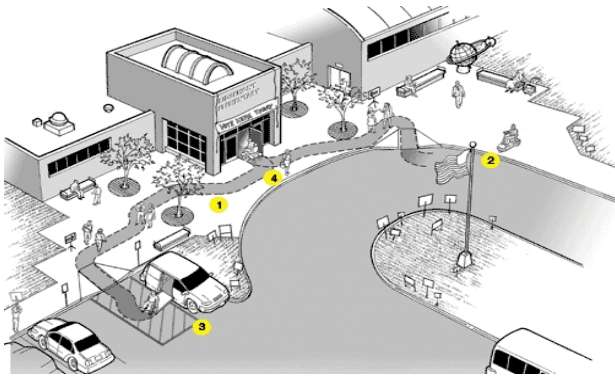

Notes for this illustration of an accessible entrance to a polling place with accessible parking and an accessible drop-off area:

1. Accessible route.
2. Accessible drop-off area.
3. Accessible parking with van accessible parking space.
4. Accessible entrance to polling places.

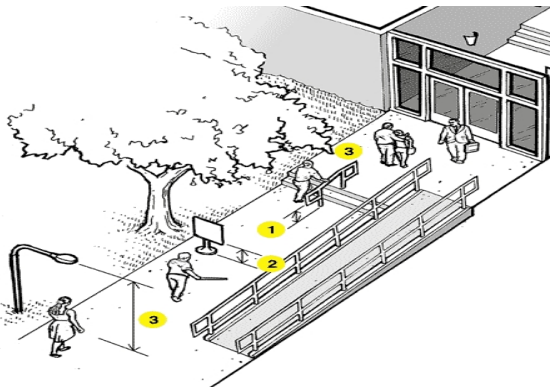

Notes for this illustration of an accessible entrance for individuals who are visually impaired or blind:

1. The bottom of the handrail extensions turn down so a person who is visually impaired or blind can detect the hazard before running into it.
2. Signs or other objects in the pedestrian route can be a hazard if the bottom is more than 27 inches but less than 80 inches above the route.
3. Objects that overhang the pedestrian route must be at least 80 inches above the route.

a. Accessible Parking

i. If parking areas are provided as part of the premises used as a polling place by voters, the polling place shall have accessible parking spaces specifically designated for individuals with disabilities located as close as possible to an accessible entrance, as described below, an access aisle located parallel and adjacent to the accessible parking space, and an accessible path of travel to the polling place building or facility. An accessible parking space must be signed with the International Symbol for Accessibility that is clearly visible over the hood of a vehicle.

Total Spaces for Polling Place	Required Minimum Number of Accessible Spaces
1 - 25	One van or universal accessible space w/access aisle
26 - 50	One van or universal accessible space w/access aisle + one car, van, or universal accessible space w/access aisle
51 - 75	One van or universal accessible space w/access aisle + two car, van, or universal accessible spaces w/access aisles
76 - 100	One van or universal accessible space w/access aisle + three car, van, or universal accessible spaces w/access aisles
101 - 150	One van or universal accessible space w/access aisle + four car, van, or universal accessible spaces w/access aisles
151 - 200	One van or universal accessible space w/access aisle + five car, van, or universal accessible spaces w/access aisles
201 - 300	One van or universal accessible space w/access aisle + six car, van, or universal accessible spaces w/access aisles
301 - 400	One van or universal accessible space w/access aisle + seven car, van, or universal accessible spaces w/access aisles
401 - 500	Two van or universal accessible spaces w/access aisle + seven car, van, or universal accessible spaces w/access aisle
501 - 1000	2 percent of total shall be accessible spaces, with 1 van or universal accessible space for every 8 accessible parking spaces

All three examples illustrated below show two accessible spaces with an accessible aisle and route.

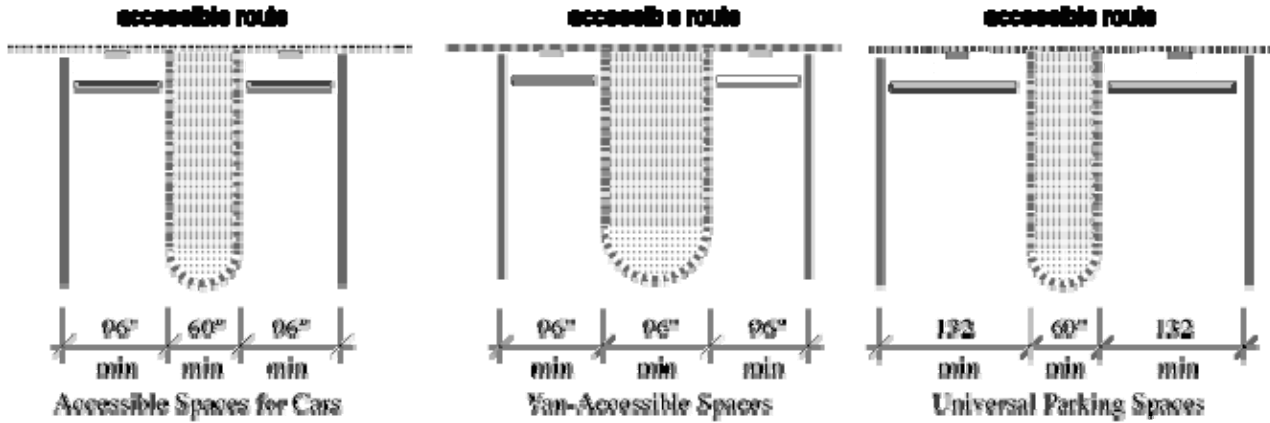

ii. The accessible parking and access aisle should be relatively level with no more than a 1:50 slope.

iii. At least one van accessible or universal parking space with an adjacent access aisle must be provided. The access aisle should connect directly to an accessible route that leads to an accessible entrance. The accessible aisle must be relatively level, clear of gravel or mud, and the surface must be in good condition without wide cracks or broken pavement. If an accessible route crosses a curb, a curb ramp must be provided.

iv. If the total number of parking spaces for a polling place requires only one accessible parking space, it must be either a van-accessible parking space or a universal parking space.

v. A van-accessible space shall be at least 96 inches wide with an adjacent access aisle that shall also be at least 96 inches wide.

vi. A universal parking space shall be at least 132 inches wide with an adjacent access aisle that shall be at least 60 inches wide.

vii. The vertical clearance for the vehicle route to the van-accessible or universal parking space, the parking space, access aisle and exit route shall be at least 98 inches in height.

viii. If the total number of parking spaces for a polling place require more than one accessible parking space, then one parking space must be a van-accessible or universal parking space and the other may be a van-accessible, universal, or car accessible parking space. A car accessible parking space shall be at least 96 inches wide with an adjacent access aisle that shall also be at least 60 inches wide. Accessible parking spaces may share an adjacent access aisle provided that the access aisle is at least 60 inches wide.

ix. If general parking is provided on the premises, but no spaces are designated as accessible parking, then a temporary accessible parking space must be created by combining existing adjoining parking spaces to make an accessible parking space and access aisle subject to the provisions set forth above in Clauses i-viii. The temporary

accessible parking shall be marked off with cones or other temporary elements.

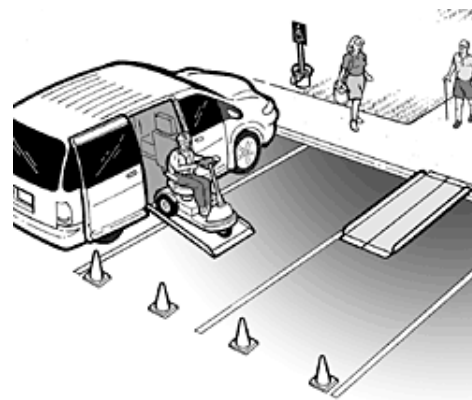

Three standard parking spaces are converted into an accessible parking space with an access aisle. Cones mark the access aisle and a temporary curb ramp with edge protection connects to an accessible route to the polling place.

x. Polling places that only provide street parking must clearly mark and sign an accessible parking space located as close as possible to an accessible route and polling place entrance. Either a curb-cut or ramp which connects directly to an accessible route must be provided.

xi. An accessible parking area which uses a portion of the general parking area as part of the exterior circulation accessible route that connects the accessible aisle to the accessible entrance must clearly delineate the access route which traverses the parking lot as a crosswalk.

xii. Accessible polling places can sometimes only be reached by traveling on gravel or other surfaces that are inhospitable to wheelchairs, walkers, and cane users. In these situations, an access aisle must be made accessible through the use of securely placed non-slip plywood, decking, or matting of sufficient thickness, which smoothes out the surface of the access aisle.

xiii. If general parking is not provided, every effort shall be made to set aside and/or reserve a temporary parking area for voters with disabilities.

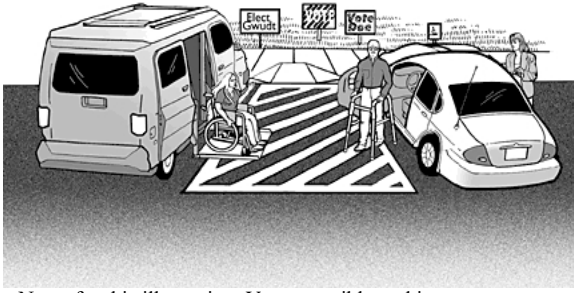

Notes for this illustration: Van-accessible parking spaces serve both cars and vans. A 96" access aisle is needed so a wheelchair lift may be lowered from the van onto the level surface.

b. Accessible Passenger Loading Zones

i. A passenger loading zone is not required, but if one is provided, it must be an accessible loading zone that is located parallel and adjacent to an access aisle. The loading zone may be located at street level or on the sidewalk. The loading zone accessible aisle must be relatively level, clear of gravel or mud, and the surface must be in good condition without wide cracks or broken pavement. The loading zone access aisle shall connect directly to an accessible route either by a curb ramp or temporary curb ramp.

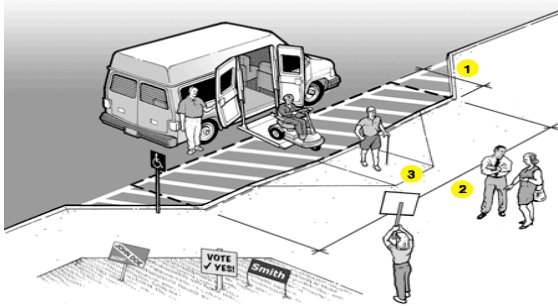

Accessible Passenger Drop-off and Loading Area

1. Access aisle depth at least 5 feet.
2. Access aisle length is at least 20 feet.
3. Curb ramp connects access aisle to the accessible entrance to the polling place.

ii. An accessible passenger loading zone which uses a portion of the general parking area as part of the exterior circulation accessible route that connects the accessible aisle to the accessible entrance must clearly delineate the access route which traverses the parking lot as a crosswalk.

iii. The accessible parking and access aisle should be relatively level with no more than a 1:50 slope.

iv. A loading zone access aisle must be at least 60 inches deep and 20 feet in length.

v. Accessible polling places can sometimes only be reached by traveling on gravel or other surfaces that are inhospitable to wheelchairs, walkers, and cane users. An access aisle may be made accessible through the use of securely placed non-slip plywood, decking, or matting of sufficient thickness, which smoothes out the surface of the access aisle.

vi. The vertical clearance for the vehicle route to the loading zone area, the drop off area, access aisle, and exit route shall be at least 114 inches in height.

c. Walkways and Sidewalks

i. The minimum clear width of walkways and sidewalks shall be at least 36 inches and may narrow briefly to 32 inches wide for up to 2 feet in length where utility poles, post-mounted signs, furniture, and doorways are located along an accessible route.

ii. Walkways and sidewalks shall be of a continuing common surface, not interrupted by changes in level of more than 1/4 inch, unless the changes are beveled; but not more than 1/2 inch, even if beveled and shall be beveled with a slope no greater than 1:12. All surfaces shall be firm and stable.

iii. Walkways with gradients steeper than 1:20 shall be considered as a ramp and must conform to the requirements of LAC 31:I.105(A)(2). Ramps on walkways shall not be steeper than 1:12.

iv. Walkways with sustained gradients of no greater than 1:20 shall have level areas of at least 60 inches long at 50 foot intervals for the purpose of rest.

v. All walkways, sidewalks, and accessible routes from a polling place drop-off place or parking area must be cleared of any object which protrudes more than 4 inches from the side and which is greater than 27 inches but less than 80 inches off of the ground. If an object cannot be moved, then a cane detectable barrier must be placed below the object within the detectable range of 27 inches or less.

vi. The undersides of exterior stairs must be enclosed or protected with a temporary or permanent cane-detectable barrier.

vii. Wherever walkways and sidewalks intersect with other walkways and sidewalks, parking lots, driveways, or streets, the surfaces shall blend to a common level.

viii. Accessible polling places can sometimes only be reached by traveling on gravel or other surfaces that are inhospitable to wheelchairs, walkers, and cane users. In these situations, walkways and sidewalks must be made accessible through the use of securely placed non-slip plywood, decking, or matting of sufficient thickness, which smoothes out the surface of the walkways or sidewalks.

2. Accessible Ramps and Temporary Accessible Ramps

a. All ramps constructed or temporarily installed in a polling place building or facility shall meet the requirements of this standard. If possible, alternative design solutions to ramps should be provided because of the substantial energy demands required to negotiate them by those in wheelchairs, plus the difficulties encountered by amputees and others with gout problems on ascent and descent ramps shall allow unrestricted traffic flow and be free of hazards.

b. Any part of a circulation path shall be considered a ramp if it has a slope that is greater than 1:20 and the rise for any run shall not exceed 30 inches long regardless of the

slope. The following table gives allowable slopes and maximum lengths.

Allowable Slope	Maximum Rise in a Single Ramp	Maximum Length of a Single Ramp Segment
1:12	2' - 6"	30' - 0"
1:16	2' - 6"	40' - 0"
1:20	2' - 6"	50' - 0"

c. A level landing area that is at least 60 inches by 60 inches must be provided where a ramp changes directions.

d. All portions of a ramp way shall have identical slopes except for the level landing areas.

e. No ramp shall exceed a slope of 1:12. However, for ramps to be constructed on existing interior or exterior areas or buildings or facilities where space limitations prohibit the use of a 1:12 slope, the slope may be 1:10 for a 6 inch rise or 1:8 for a 3 inch rise.

f. If there is a vertical drop off, an edge protection will be required to stop wheelchairs from falling off the side.

g. All ramps with a rise greater than 6 inches shall have handrails mounted between 34 and 38 inches above the ramp surface on both sides. Handrails shall be continuous along the ramp segment. If the ramp has a second lower rail sufficient to prevent an individual from slipping off the ramp, no edge protection is needed for the ramp.

h. Ramps shall have a minimum clear width measured between the handrails of 36 inches.

i. Ramps shall have level platforms at the bottom and the top of each run that are at least 60 inches long and at least as wide as the ramp. Intermediate platforms between each ramp segment shall be at least 60 inches in length. See above Table (LAC 31:105.A.2.b) for the maximum allowable lengths of ramp segments.

j. Intermediate turning platforms shall be a minimum of 60 inches in length and 60 inches wide to allow wheelchair maneuvering through 180 degrees.

k. If doors open out onto the ramp platform, a level area at least 5 feet deep and 5 feet wide shall be provided.

l. The ramp surface shall be slip resistant.

m. No objects shall be hung from above or the sides of a ramp way that projects lower than 90 inches from the surface of the ramp or landing. Below this height, no object shall project into a ramp way other than the handrails.

n. A portable temporary ramp may be used if steps are higher than 1/2 inch and are not accessible to wheelchair users.

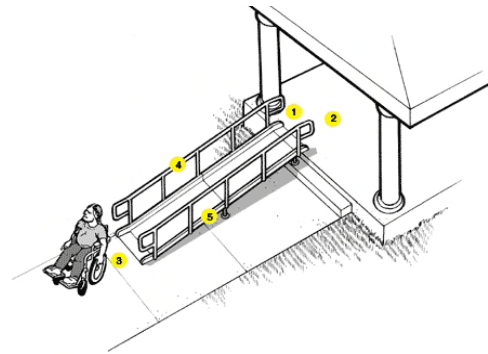

Notes for this illustration of a ramp:

1. At least 36 inches between handrails.
2. Top landing part of walk.
3. Bottom landing part of walk.
4. Handrail height 34 to 38 inches.
5. Edge protection.

3. Entrances, Doors, and Doorways

a. At least one entrance and exit to the polling place building and its interior rooms shall be accessible, and shall be located on an accessible route as described above. The accessible entrance to the polling place should be identified and marked using the International Symbol for Accessibility. Accessible entrance signs are included in the precinct supply packages on election day for the election to be posted at the accessible entrance on election day. Inaccessible entrances shall be marked with the same signs indicating the direction to the nearest accessible entrance.

b. The floor on the inside and outside of each doorway shall preferably be level, but may slope no more than 1:50.

c. Entrances shall have a minimum clear width of 32 inches. This dimension shall be measured from the face of the door to the face of the door stop. Where double doors are used, at least one leaf shall allow a 32 inches clear opening.

d. The minimum space between two hinged doors in a series shall be the width of the door swinging into the space plus 48 inches. Door swings of doors in series shall open in the same direction. Single doors hung in series shall be hinged at the same side.

e. At vestibules where doors are at right angles to each other, the dimension between the wall with the in swinging door and the facing wall shall be 78 inches. The minimum dimension in the other direction shall be 60 inches.

f. If the above specification cannot be satisfied, then one of the two doors shall be securely fastened in an open position during the hours when the polling place is open.

g. If there are security reasons why the accessible entrance door must remain closed or locked, a wireless doorbell system can be used notifying the poll worker to open the door for the elderly or individual with disabilities. If a wireless doorbell system is used, a sign should be posted instructing the voter to ring for immediate assistance and access.

ELECTIONS

h. The maximum height of thresholds at exterior and interior doors shall not be more than 1/4 inch, unless beveled. Thresholds which are greater than 1/4 inch but not more than 1/2 inch high must be beveled or replaced with a new beveled threshold that is not more than 1/2 inch high.

i. Doors should be operable without movements requiring a tight grasp, complex hand movements, or the exertion of great force. In addition, for doors that have hardware that cannot be manipulated by a closed fist, retrofit kits may be used to render the door accessible.

j. To be accessible, the width of a door should be at least 32 inches. If the width of a doorway is affected by its hinges, door widening hinges can be used to widen a door up to 2 inches.

4. Interior Circulation Routes

a. There shall be an accessible, convenient, and clear path of travel from an accessible entrance to the voting area within the polling place.

b. The voting area in the polling place building or facility shall be served from an accessible entrance by at least one path of travel that does not have stairs or escalators.

c. The minimum clear width of halls, corridors, passageways, and aisles shall be 36 inches wide and may narrow briefly to 32 inches wide where the route passes through doors or next to furniture and building elements.

d. No rigid or hard objects shall project into the space above the path of travel unless the dimension from the bottom edge of the object to the walk surface is at least 80 inches above the floor.

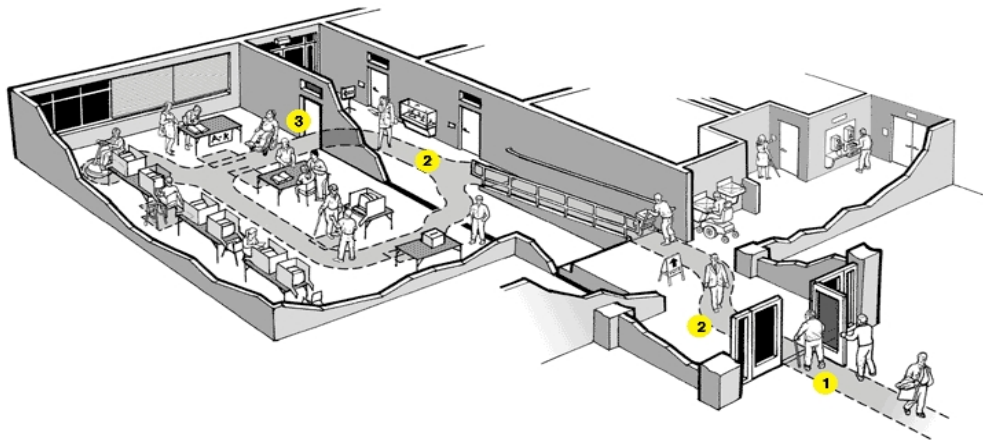

Notes for accessible interior circulation at the polling place from the accessible entrance to the voting area.

1. Accessible entrance.
2. Accessible route connects the accessible entrance with the voting area.
3. Accessible door to the voting area.

5. Elevators. If elevators are necessary to access the voting area, the elevators shall be on an accessible route and shall comply with the American National Standard Safety Code for Elevators, Dumb-Waiters, Escalators and Moving Walks, ANSI A117.1 1980.

AUTHORITY NOTE: Promulgated in accordance with R.S. 18:533, R.S. 36:742, 42 U.S.C. §1973ee et seq., Public Law 107-252, 28 CFR Part 36 (4.1.2), 28 CFR Part 34 (4.6), and 28 CFR Part 34 (A.4.6).

HISTORICAL NOTE: Promulgated by the Department of State, Secretary of State, LR 35:1258 (July 2009).

§107 Guidelines for Polling Places

A. The guidelines set forth herein are only guidelines for physical accessibility of polling places and cannot be construed to authorize or require conduct prohibited under any of the following laws, or to supersede, restrict, or limit the application of such laws:

1. the Voting Rights Accessibility for the Elderly and Handicapped Act (42 U.S.C. §1973ee et seq.);

2. the Americans with Disabilities Act of 1990 (42 U.S.C. 12101 et seq.) and ensuing regulations; and

3. the Rehabilitation Act of 1973 (29 U.S.C. 701 et seq.) and ensuing regulations.

AUTHORITY NOTE: Promulgated in accordance with R.S. 18: 533, R.S. 36:742, 42 U.S.C. §1973ee et seq., and Public Law 107-252.

HISTORICAL NOTE: Promulgated by the Department of State, Election Division, LR 35:1262 (July 2009).

§109. Exemption Procedures

A. If the present polling place building or facility cannot reasonably be made either permanently accessible or temporarily accessible for election day by the owner or the parish for use on election day, and the parish governing

authority cannot locate any other building or facility in the precinct area for use as a polling place on election day that meets these accessibility rules or it is not feasible to move the polling place to an accessible building or facility outside of the precinct, then the parish governing authority may request an exemption for use of the non-accessible polling place.

B. A request for an exemption shall be in writing to the Secretary of State, and shall include the following:

1. an accessibility survey for the present polling place for which the exemption is being sought, identifying all of the deficiencies of the building or facility;

2. a description of all efforts made to relocate the polling place to an accessible building;

3. a description of what continued efforts will be made by the parish to achieve compliance during the period that the exemption is in effect;

4. a statement of the approximate length of time needed to meet the compliance requirements; and

5. the signature of the presiding official of the parish governing authority; and

6. any document(s) supporting the parish's request for the exemption shall be included in the request.

C. The Secretary of State may grant an exemption to the accessibility requirements for a requested polling place in the case of an emergency as provided under R.S. 18:401 et seq., or upon a showing in writing by the parish governing authority that a polling place cannot reasonably be made either permanently accessible or temporarily accessible for an election for non-emergency reasons.

D. Any granted exemption to a polling place is valid for only one election cycle which includes all primary and general elections, unless otherwise stated by the Secretary of State.

E. For any polling place which receives an exemption hereunder, the parish governing authority shall certify to the Secretary of State, in writing, that reasonable notice was given to all eligible voters in the precinct that their polling place is not accessible but that they may vote either at the registrar of voter's office during early voting, or at an alternate accessible polling location on election day as directed by the registrar of voters. The address of the alternate accessible location shall be specified in the notice. Reasonable notice shall include posting of public notice at the parish courthouse and at the non-accessible polling place, mailing of notice no later than 21 days to all eligible voters prior to an election, and advertisement in the official parish journal or the local newspaper of general circulation, telephone, television, and/or radio at the cost of the parish governing authority.

F. A certification of exemption from these accessibility requirements may be requested by the parish to the Secretary of State by telephone or other electronic means, provided it is followed up in writing as soon as practicable as provided for herein.

AUTHORITY NOTE: Promulgated in accordance with R.S. 18: 533, R.S. 36:742, 42 U.S.C. 1973ee et seq., and Public Law 107-252.

HISTORICAL NOTE: Promulgated by the Department of State, Elections Division, LR 35:1263 (July 2009).

§111. Repeal Prior Rules and Regulations

A. All rules and regulations adopted by the Department of Elections and Registration in April 1986 are hereby repealed in their entirety.

AUTHORITY NOTE: Promulgated in accordance with R.S. 18: 533, R.S. 36:742, 42 U.S.C. 1973ee et seq., and Public Law 107-252.

HISTORICAL NOTE: Promulgated by the Department of State, Elections Division, LR 35:1263 (July 2009).

Chapter 3. Opportunity to Cure Deficiencies in Absentee by Mail Ballots

§301. Absentee by Mail Ballot Deficiencies that May Be Cured

A. Each registrar of voters shall review the absentee by mail ballot envelope flap for the following deficiencies:

1. missing voter signature;

2. missing witness signature; and incomplete affidavit information, including but not limited to missing election date and voter information.

This review shall be conducted immediately upon receipt of the absentee by mail ballot.

AUTHORITY NOTE: Promulgated in accordance with R.S. 18:18(A)(3) and R.S. 36:742.

HISTORICAL NOTE: Promulgated by the Department of State, Elections Division, LR 47:1538 (October 2021).

§303. Absentee Ballot Deficiency Notification

A. Upon receipt of an absentee by mail ballot envelope flap with one or more of the above identified deficiencies, the registrar of voters shall segregate the ballot envelope and promptly notify the voter of the ballot envelope flap deficiency and of the opportunity to cure the deficiency.

B. The registrar of voters shall identify the ballot in the voter's absentee record and notate it as "deficient with opportunity to cure."

C. The registrar shall immediately mail a written notice of the ballot envelope flap deficiency and the opportunity to cure the deficiency. If there is a telephone number or email address available in the voter's registration record, the registrar shall also attempt to contact the voter by telephone or email.

D. All deficiency notifications shall inform the voter of the type of deficiency, the process for curing the deficiency, and the deadline and method to cure the deficiency. The registrar shall make a log of the date and methods of contact for each voter.

E. Effective February 1, 2022, there will be a space on the Secretary of State website area to Check Absentee

Ballots indicating that the voter has been notified of an opportunity to cure a deficiency.

F. Voters are required to appear in person at their registrar of voters office during normal business hours until 4:30 p.m. the day before the election to cure the ballot envelope flap deficiency.

AUTHORITY NOTE: Promulgated in accordance with R.S. 18:18(A)(3) and R.S. 36:742.

HISTORICAL NOTE: Promulgated by the Department of State, Elections Division, LR 47:1538 (October 2021).

§305. Curing Absentee by Mail Ballot Deficiencies

A. To cure a missing voter signature, the voter shall appear at the office of the registrar and sign the ballot envelope flap in the presence of an employee of the registrar of voters. The employee of the registrar who observes the signature shall also sign the ballot envelope flap as witness.

B. To cure a missing witness signature, the voter shall appear at the office of the registrar and resign the ballot envelope flap in the presence of an employee of the registrar of voters. The employee of the registrar who observes the signature shall sign the ballot envelope flap as witness.

C. To cure an incomplete affidavit, the voter shall appear at the office of the registrar and complete the affidavit on the ballot envelope flap.

D. If the voter appears at the office of the registrar to cure the deficiency, the notation in the voter's absentee record shall be updated to so reflect.

AUTHORITY NOTE: Promulgated in accordance with R.S. 18:18(A)(3) and R.S. 36:742.

HISTORICAL NOTE: Promulgated by the Department of State, Elections Division, LR 47:1538 (October 2021).

Chapter 5. Election Night Transmission of Results

§501. Responsibility of Secretary of State

A. The Secretary of State shall provide each clerk of court's office with written instructions on the election results transmission process.

B. These written instructions shall provide specific uniform tasks that must be performed by the clerk of court's office to effectively transmit election night results.

AUTHORITY NOTE: Promulgated in accordance with R.S. 18:576(B) and R.S. 36:742.

HISTORICAL NOTE: Promulgated by the Department of State, Elections Division, LR 33:1881 (September 2007).

§503. Responsibility of Clerk of Court

A. The clerk of court shall follow proper procedures for transmitting all election results, as provided by the transmittal procedures established by the department.

AUTHORITY NOTE: Promulgated in accordance with R.S. 18:576(B) and R.S. 36:742.

HISTORICAL NOTE: Promulgated by the Department of State, Elections Division, LR 33:1881 (September 2007).

§505. Transmission of Election Night Returns

A. The clerk of court's office shall immediately load the contents of election results cartridges onto the Department of State's laptop as they are received by the clerk of court. Once all of the cartridges for a whole precinct are loaded onto the laptop, the clerk of court's office shall immediately transmit the election results to the Louisiana Secretary of State's Elections and Registration Information Network (ERIN) and verify that the system is properly transmitting election results. The clerk of court may verify by checking ERIN and/or the Secretary of State's website (www.GeauxVote.com) for the posting of the first transmission of election returns, or by telephoning the department's election division.

B. Once it has been verified that the first transmission was successful, the clerk of court shall transmit all remaining election results to the Department of State at least every 30 minutes or less, until all election results cartridges have been loaded and transmitted according to transmittal procedures established by the department.

C. The transmission of election results shall begin no later than 45 minutes after the polls are closed unless there is a technical or unforeseen problem which prevents the clerk of court from doing so, in which case the clerk shall contact the department to communicate such information.

D. If the clerk of court's office has its own computer system to display election results, the results shall be loaded onto that system only after the information has been properly transmitted to the department, and such results shall be displayed and clearly identified as the unofficial results of the clerk of court. However, in the event of a technical or unforeseen problem which prevents the clerk of court from transmitting election results to the department, after communicating such information to the department, the clerk may display election results on his own computer system.

E. Any election results posted in the clerk of court's office obtained or displayed from of the Department of State's webpage or ERIN shall be clearly identified as the Department of State's unofficial results.

F. The clerk of court shall check ERIN and/or the Secretary of State's website (www.GeauxVote.com) for the posting of the election returns in their parish to verify that all precincts are posted, with 100 percent reporting before closing their office for the evening. Each race must show all precincts reporting prior to ending the transmission process. The clerk of court should contact the Department of State before leaving for the night.

AUTHORITY NOTE: Promulgated in accordance with R.S. 18:576(B) and R.S. 36:742.

HISTORICAL NOTE: Promulgated by the Department of State, Elections Division, LR 33:1881 (September 2007).

Chapter 7. Election Expense Reimbursement

§701. Department of State's Election Expense Manual

A. The department shall develop and adopt an Election Expense Manual that shall be utilized by clerks of court, registrars of voters, parish boards of election supervisors, and other sources (e.g., law enforcement officers) as needed to determine eligibility of reimbursement and/or payment of election expenses and other related expenses. The manual shall provide information as to the required supporting documents that must be attached to the invoice before payment can be made. In the event of an unusual expense, the manual will provide information on how to obtain approval in advance of the expense.

B. Under the provisions of the Election Code, R.S. 18:1400.3 and 1400.4, election expenses incurred by either the clerk of court, the registrar of voters, or the parish board of election supervisors will be reimbursed or paid by the Department of State from funds appropriated for that purpose. After all election expenses have been paid and reconciled, these expenses will be allocated to the state or parish governing authorities under the prorated provisions of R.S. 18:1400.3, R.S. 18:1400.4, and R.S. 18:1400.5. Invoices will then be generated to the appropriate party.

C. The procurement of all goods and services shall be done in accordance with purchasing procedures established by the Office of State Purchasing or the parish governing authority.

D. The payment for mileage shall be based upon the mileage rate established by the Office of State Travel in General Travel Regulations (Policies and Procedure Memorandum Number 49).

E. Reimbursement for copies will be based upon the state's uniform copy rate (LAC 4:I.301) established for all state agencies. If a parish has officially adopted their own rate, a copy of the adoption of a rate must be provided to the Department of State with a request to allow the parish's copy rate.

F. The Election Expenses Manual shall be submitted to the state attorney general's office for approval. Any updates to the manual shall also receive approval by the state attorney general's office.

G. The Election Expense Manual shall be submitted to the Committee on House and Governmental Affairs and the Senate and Governmental Affairs Committee for informational purposes. Both committees shall receive any changes to the manual.

H. Copies of the final Election Expense Manual may be viewed at the Office of State Register (Claiborne Building, 1201 N. Third St., Suite 3-220, Baton Rouge, LA) or at the Department of State (Broadwing Building, Elections Division, 8549 United Plaza Blvd., Baton Rouge, LA).

AUTHORITY NOTE: Promulgated in accordance with R.S. 18:18(A)(5), R.S.18:1400.3, R.S. 18:1400.4, R.S. 18:1400.5, R.S. 36:742, and R.S. 49:950 et seq.

HISTORICAL NOTE: Promulgated by the Department of State, Elections Division, LR 33:1880 (September 2007).

§703. Clerk of Court Expenses

A. The Election Expense Manual shall clearly set forth a listing of expenses for clerks of court which are authorized for reimbursement and/or payment, and a listing of expenses for which advance approval by the Secretary of State is required, and a listing of unauthorized expenses.

B. If a clerk of court's expense requires written approval in advance, the request should be submitted two weeks in advance of the anticipated expense to the Secretary of State, or his designee. The approval letter or request should accompany the invoice for payment.

C. Request for approval for any emergency expense may be done by telephone or email and reduced to writing thereafter.

AUTHORITY NOTE: Promulgated in accordance with R.S. 18:18(A)(5), R.S.18:1400.3, R.S. 36:742, and R.S. 49:950 et seq.

HISTORICAL NOTE: Promulgated by the Department of State, Elections Division, LR 33:1880 (September 2007).

§705. Registrar of Voters Expenses

A. The Election Expense Manual shall clearly set forth a listing of expenses for registrars of voters which are authorized for reimbursement and/or payment, and a listing of expenses for which advance approval by the Secretary of State is required, and a listing of unauthorized expenses.

B. If a registrar of voters' expense requires written approval in advance, the request should be submitted two weeks in advance of the anticipated expense to the secretary or his designee. The approval letter or request should accompany the invoice for payment.

C. Request for approval for any emergency expense may be done by telephone or email and reduced to writing thereafter.

AUTHORITY NOTE: Promulgated in accordance with R.S. 18:18(A)(5), R.S.18:1400.3, R.S. 36:742, and R.S. 49:950 et seq.

HISTORICAL NOTE: Promulgated by the Department of State, Elections Division, LR 33:1880 (September 2007).

§707. Parish Board of Election Supervisors Expenses

A. The Election Expense Manual shall clearly set forth a listing of expenses for the parish boards of election supervisors which are authorized for reimbursement and/or payment, and a listing of expenses for which advance approval by the Secretary of State is required, and a listing of unauthorized expenses.

B. If a parish board of election supervisors' expense requires written approval in advance, the request should be submitted two weeks in advance of the anticipated expense to the secretary or his designee. The approval letter or request should accompany the invoice for payment.

C. Request for approval for any emergency expense may be done by telephone or email and reduced to writing thereafter.

AUTHORITY NOTE: Promulgated in accordance with R.S. 18:18(A)(5), R.S.18:1400.4, R.S. 36:742, and R.S. 49:950 et seq.

HISTORICAL NOTE: Promulgated by the Department of State, Elections Division, LR 33:1881 (September 2007).

§709. Deadline for Submission of Expenses to Department of State

A. All requests for reimbursement or payment of expenses shall be submitted to the department no later than 60 days following an election or the transaction.

B. If the request for reimbursement or payment is not received within this 60 day period, the department may notify the appropriate party by certified mail that the request will be disapproved for payment if not made within 10 days from receipt of this notice.

AUTHORITY NOTE: Promulgated in accordance with R.S. 18:18(A)(5), R.S.18:1400.3, R.S. 18:1400.4, R.S. 18:1400.5, R.S. 36:742, and R.S. 49:950 et seq.

HISTORICAL NOTE: Promulgated by the Department of State, Elections Division, LR 33:1881 (September 2007).

Chapter 8. Voting Technology

Subchapter A. Private Elections

§801. Type of Election

A. The following are the different types of private elections which may be conducted utilizing the department's staff:

1. primary school, middle school, and high school elections. Examples include: the Reader's Choice elections; student government officers' elections; and homecoming elections. This type of private election would be considered an educational election with the purpose of informing students interested in voter registration and voting and would be done on a gratuitous basis with no charge for services or expenses by the department;

2. public service organizations. Examples include: active military organizations; Louisiana State Legislature; Louisiana State Police. This type of private election would be considered a public service and would be done on a gratuitous basis with no charge for services or expenses by the department;

3. disability organization elections. An example would be an election for officers of a disability organization. This type of private election would be an outreach event and would be done on a gratuitous basis with no charge for services or expenses by the department;

4. private entity or organization elections. Examples include officers for a private entity or organization such as: a union or other association; higher education student government officers; and political party elections for convention delegates. Private elections would be conducted on a reimbursement basis for services and expenses as provided for herein.

AUTHORITY NOTE: Promulgated in accordance with R.S. 18:21 and R.S. 36:742.

HISTORICAL NOTE: Promulgated by the Department of State, Elections Division, LR 43:2192 (November 2017).

§803. Private Elections Manual

A. Due to the department's primary function of conducting state elections, department staff may not be available to conduct private elections. The department shall develop and adopt a private elections manual providing procedural information on private elections, including but not limited to:

1. ballot format guidelines;
2. calendar of available dates for private elections;
3. deadlines for requesting and contracting for a private election; and
4. cost estimate information and sample contract.

B. Upon the request for a private election, a listing of all available recommended services and expenses for a particular private election and the associated costs, if any, will be estimated by the department and given to the requestor for the signing of a contract.

C. All private elections must have a signed contract, dated and returned to the department by the deadline set forth by the department. A signed contract evidences acceptance of the department's recommended services and expenses for a private election and associated costs, if any. The acceptable method of delivery of the contract is Federal Express or hand delivery to the Department of State, Elections Division, Elections Operations Section, Twelve United Plaza Building, 8585 Archives Blvd., Suite 110, Baton Rouge, LA 70809-2414.

D. Payment of private elections, if any, must be made at the time of the delivery of the contract to the department. The acceptable methods of payment for the department's services and expenses shall be by certified check or money order made payable to the Department of State.

E. If drayage services are required for a private election, payment for such services must be included with the signed and dated contract prior to the deadline set forth by the department. The acceptable method of payment shall be by separate check made payable to the drayage contractor.

F. If paper ballots are required for a private election, payment for such expense must be included with the signed and dated contract prior to the deadline set forth by the department. The acceptable method of payment shall be by separate check made payable to the ballot printing contractor.

G. Cancellations will be accepted up to two weeks prior to a private election with a 50 percent refund for department services and 100 percent refund of drayage services. No refund for ballot printing expenses will be issued unless the ballots have not been printed. Any cancellation thereafter will not be refunded.

H. All private election funds received shall be deposited into the voting technology fund.

AUTHORITY NOTE: Promulgated in accordance with R.S. 18:21 and R.S. 36:742.

HISTORICAL NOTE: Promulgated by the Department of State, Elections Division, LR 43:2193 (November 2017).

§805. Department Election Expenses

A. The cost estimate of a private election in §801.A.3 may include:

1. \$100 for one race or more races on the same ballot style;
2. \$100 for each additional ballot style; and
3. \$100 per voting unit.

AUTHORITY NOTE: Promulgated in accordance with R.S. 18:21 and R.S. 36:742.

HISTORICAL NOTE: Promulgated by the Department of State, Elections Division, LR 43:2193 (November 2017).

Subchapter B. Maps of Precincts and Election Jurisdictions

§809. Maps of Precincts and Election Jurisdictions

A. The secretary of state may produce and sell electronic images mapping precincts and election jurisdictions in Louisiana. The fee for the digital file shall be \$1 per precinct. The acceptable methods of payment are by credit card or certified check or money order made payable to the Department of State. Payment may be made online, by mail, or in person to the Department of State, Elections Division, Registration Section, 8585 Archives Blvd., P.O. Box 94125, Baton Rouge, LA 70804-9125.

AUTHORITY NOTE: Promulgated in accordance with R.S. 18:21 and R.S. 36:742.

HISTORICAL NOTE: Promulgated by the Department of State, Elections Division, LR 43:2193 (November 2017).

Chapter 9. Recognition of Political Parties

§901. Purpose

A. The purpose of this Chapter is to establish minimum guidelines to be used by the Secretary of State in recognizing political parties pursuant to R.S. 18:441B.

AUTHORITY NOTE: Promulgated in accordance with R.S. 18:441 and R.S. 36:742.

HISTORICAL NOTE: Promulgated by the Department of State, Elections Division, LR 34:703 (April 2008).

§903. Definitions

A. For the purposes of this Rule, the following definitions shall apply.

Deceptively Similar—a political party name which deceives the general public into believing that said political party is that of another party, when in fact, the two parties are not affiliated with each other.

Identical—the same exact political party name, even though the two parties are not affiliated with each other.

AUTHORITY NOTE: Promulgated in accordance with R.S. 18:441 and R.S. 36:742.

HISTORICAL NOTE: Promulgated by the Department of State, Elections Division, LR 34:703 (April 2008).

§905. Political Party Recognition Based on Registered Voters

A. A political party which seeks recognition must have at least 1,000 registered voters in the state of Louisiana who are registered as being affiliated with such political party.

B. A political party shall request a list of registered voters from the Secretary of State who are registered as being affiliated with the political party who is seeking recognition in order to verify that the political party has at least 1,000 registered voters. The Secretary of State shall date this list of registered voters.

C. This list of registered voters shall be provided by the Secretary of State's office, using the political party name given by the requestor, and shall be limited to the exact name provided. For example, a request for a list of registered voters with the "Green Party" would not include "Green," "Green Grass," "Green Labor," "Green Peace," "Greenpeace" or "Greens."

D. All of the following requirements shall be met by the political party for recognition by the Secretary of State.

1. A notarized registration statement must be filed with the Secretary of State no later than 90 days prior to the opening of the qualifying period for any election.

2. The registration statement must be accompanied by a fee in the amount of \$1,000, made payable to the Department of State only by certified, cashier's check on a state or national bank or credit union, United States postal money order, or money order issued by a state or national bank or credit union.

3. The registration statement must be accompanied by a list of registered voters provided by the Department of State pursuant to §905.B with the exact political party name, showing at least 1,000 voters and dated no less than 90 days prior to the opening of the qualifying period for any election.

AUTHORITY NOTE: Promulgated in accordance with R.S. 18:441 and R.S. 36:742.

HISTORICAL NOTE: Promulgated by the Department of State, Elections Division, LR 34:703 (April 2008).

§907. Defects in a Registration Statement

A. No registration statement of a political party shall be accepted by the Secretary of State, if the Secretary of State finds any of the following defects.

1. A political party's name is identical or deceptively similar to the name of any existing national party, yet the two political parties are not affiliated based on information from the national party.

2. A political party's name is identical or deceptively similar to the name of any currently recognized political party.

3. A political party's name is deliberately misleading or fraudulent in any respect.

4. A political party's emblem is deceptively similar to an emblem or trademark of any other existing recognized political party.

5. A political party that attempts to be recognized in this state with the name "Independent" or "the Independent Party."

6. A political party's registration statement is incomplete and/or does not provide the required information. In such a case, the political party may resubmit a completed notarized registration statement without having to pay an additional registration fee. The Secretary of State must receive a resubmitted registration statement no less than 90 days prior to the opening of the qualifying for any election, for recognition to apply in that primary or general election.

B. The Secretary of State shall return the rejected registration statement, along with the registration fee, except in the case of an incomplete statement, where the political party chooses to resubmit a completed notarized registration statement.

AUTHORITY NOTE: Promulgated in accordance with R.S. 18:441 and R.S. 36:742.

HISTORICAL NOTE: Promulgated by the Department of State, Elections Division, LR 34:703 (April 2008).

§909. Objection to a Registration Statement

A. Any person aggrieved by the recognition of political party based on the filing of a registration statement alleged to be false, fraudulent, deceptive, substantially misleading or otherwise prohibited by law may file an objection in writing to the Secretary of State.

B. The objection must be filed within two years of the political party's registration filing.

C. The Secretary of State shall provide written notice to the recognized political party whose registration statement is objected to and include with the notice a copy of the objection and any related documentation provided with the objection. The recognized political party may file a written response to the objection with the Secretary of State within 10 days of the date of mailing of the notice by the Secretary of State.

D. The Secretary of State must determine the validity of the objection, by determining whether the political party's registration statement is defective, based on the objection, any related documentation provided with the objection and, if applicable, the response to the objection from the recognized political party.

E. If the Secretary of State determines that the objection is valid, he shall declare the political party's registration statement null and void and cancel the political party's recognition. The Secretary of State shall provide written notice of his decision and the effective date to the political party.

F. The Secretary of State shall not return the registration fee when a political party's registration is canceled pursuant to the provisions herein.

AUTHORITY NOTE: Promulgated in accordance with R.S. 18:441 and R.S. 36:742.

HISTORICAL NOTE: Promulgated by the Department of State, Elections Division, LR 34:703 (April 2008).

§911. Notification

A. The Secretary of State shall provide written notice to a political party that seeks recognition that the political party's registration statement is rejected for any of the reasons set forth in §907 through §909 above.

AUTHORITY NOTE: Promulgated in accordance with R.S. 18:441 and R.S. 36:742.

HISTORICAL NOTE: Promulgated by the Department of State, Elections Division, LR 34:704 (April 2008).

Chapter 11. Emergency Election Day Paper Ballot Voting Procedures

§1101. Emergency Declaration

A. The Department of State is establishing emergency election day paper ballot voting procedures to be followed if a precinct does not have a voting machine that is operable and the precinct is not located in a consolidated precinct which has the ballot for which the voters are eligible to vote on a voting machine and the secretary of state or his designee declares an emergency.

AUTHORITY NOTE: Promulgated in accordance with R.S. 18:1352, R.S. 18:1353, and R.S. 36:742.

HISTORICAL NOTE: Promulgated by the Department of State, Elections Division, LR 39:1055 (April 2013).

§1103. Preparation and Supplies for Implementation of Emergency Election Day Paper Ballot Voting Procedures

A. Emergency Declaration—Preparation Prior To Election Day

1. The secretary of state or his designee shall review all voting machine allocation reports and provide supplies for implementation of the emergency election day paper ballot voting procedures for any precinct which has only one voting machine allocated for the election and is not located in a consolidated polling place which has the ballot for which the voters are eligible to vote on a voting machine. Supplies shall be provided in the back of the voting machine for immediate implementation upon a written declared emergency.

2. The clerk of court shall provide training to the commissioners for each one voting machine precinct on the implementation of the emergency election day paper ballot voting procedures as provided for herein.

3. The clerk of court shall inform the parish board of election supervisors or the absentee commissioners appointed to count the mail and early voting ballots of the possibility of having to implement the emergency election day paper ballot voting procedures due to the one machine precinct(s) in the parish.

B. Emergency Declaration—Supplies and Implementation Procedures

1. The commissioner-in-charge shall follow the directions in his parish for notifying the clerk of court and the Department of State when a precinct does not have a voting machine that is operable. The clerk of court, registrar

of voters, and the secretary of state, or his designee, shall consult on the matter before an emergency is declared.

2. If the secretary of state, or his designee, declares an emergency, the secretary, or his designee, shall notify the clerk of court in writing, who shall notify the commissioners to implement the emergency election day paper ballot voting procedures provided for herein. The clerk of court shall also notify either the parish board of election supervisors or the appointed absentee commissioners of the declared emergency, so that they will be available to count the paper ballots on election night.

3. The secretary of state will provide all ballots and supplies to be used for the emergency election day paper ballot voting procedures. Supplies shall include: paper ballots identified by the corresponding button number of the machine lockout for the precinct and secrecy envelopes; a notice to the voters to be posted; instructions for the commissioners; a paper ballot audit form (in duplicate) to be used by the commissioners; a large return envelope labeled election day voted paper ballots; and any other supplies as determined necessary by the secretary or his designee.

4. The commissioner-in-charge shall post a notice at the entrance to the polling place notifying the voters that they will be allowed to vote on paper ballots. The commissioner-in-charge shall remove the notice when the precinct has a voting machine that is operable and voting resumes on the voting machine.

5. The commissioners shall use the instructions provided to follow the proper procedures in implementing the emergency election day paper ballot voting procedures.

6. The commissioner-in-charge shall complete the relevant parts of the paper ballot audit form prior to distribution of any paper ballot, such as the parish/ward/precinct information, time of implementation of procedures, lockout button number on ballot envelope, and total number of ballots per lockout button received in the lead machine. The commissioner-in-charge shall use this form to account for the number of voted paper ballots sealed in secrecy envelopes per button number, the number of spoiled ballots sealed in secrecy envelopes per button number, and the number of unused ballots per button number. This information will provide an accurate accounting of the paper ballots supplied to the precinct per button number. At the end of the election day, the original paper ballot audit form shall be placed in the large return envelope labeled election day voted paper ballots for delivery to the clerk of court and a duplicate copy shall be posted at the precinct.

7. Paper ballots shall only be used during the time when the precinct does not have a voting machine that is operable and the secretary of state or his designee has declared an emergency in writing for implementation of the emergency election day paper ballot voting procedures.

AUTHORITY NOTE: Promulgated in accordance with R.S. 18:551, R.S. 18:1352, R.S. 18:1353, and R.S. 36:742.

HISTORICAL NOTE: Promulgated by the Department of State, Elections Division, LR 39:1056 (April 2013).

§1105. Procedures for Voting and Termination of Voting for Paper Ballots

A. Allowing the Voters to Vote Paper Ballots

1. The commissioner shall continue to follow the normal procedures of verifying the voter and having the voter sign the precinct register as provided in the "Election Day Procedures" provided in Part 3 of the *Informational Pamphlet for Election Day Voting*.

2. Additionally, the commissioner shall initial the precinct register opposite the voter's signature or mark and write "Paper Ballot" in the "Lockout Districts" column on the line in the precinct register where the voter is listed.

3. After the commissioner initials the precinct register and writes "Paper Ballot" in the precinct register, the commissioner shall:

a. remove a ballot and secrecy envelope from the large ballot envelope labeled with the button number for the voter that is listed in the precinct register and account for the distribution of that specific ballot number on the paper ballot audit form. (Hash marks or similar counting marks may be used and then totaled at the end of voting to report a final total for each column on the paper ballot audit form.);

b. give the voter the ballot, the secrecy envelope and a pencil or pen;

c. instruct the voter to read and follow the instructions at the top of the ballot to mark the ballot according to those instructions and to seal the ballot in the secrecy envelope after he has completed voting;

d. the commissioner shall allow the voter to go to an area inside the polling place where he can mark his ballot in private and seal his voted ballot in the secrecy envelope; and

e. instruct the voter to return the sealed voted ballot in the secrecy envelope to the commissioner.

4. If the voter spoils his ballot and requests a new ballot, the commissioner shall:

a. instruct the voter to seal his spoiled ballot in the secrecy envelope before collecting the spoiled ballot;

b. write "Spoiled" across the ballot envelope and initial;

c. give the voter a new ballot; and

d. account for the distribution of the new ballot and the spoiled ballot on the paper ballot audit form and place the spoiled ballot envelope in the large return envelope labeled election day voted paper ballots.

5. Upon receipt of the voted ballot in the secrecy envelope from the voter, the commissioner shall account for the voted ballot on the paper ballot audit form and place the secrecy envelope in the large return envelope labeled election day voted paper ballots. The secrecy envelopes with the voted paper ballots shall be retained in the election day voted paper ballots envelope.

B. Termination of Voting Paper Ballots

1. Paper ballots shall only be used during the time when the precinct does not have a voting machine that is operable and the secretary of state, or his designee, has declared an emergency in writing for implementation of the emergency election day paper ballot voting procedures.

2. The commissioner-in-charge shall notify the clerk of court when the voting of paper ballots is terminated due to an operable voting machine and shall indicate the time on the paper ballot audit form. The clerk of court shall then notify the secretary of state, or his designee.

C. Closing the Polling Place

1. After the closing of the polling place, the commissioners shall follow the instructions to complete the paper ballot audit form and certify to its accuracy and place the original paper ballot audit form, all sealed secrecy envelopes containing voted ballots, all spoiled ballot envelopes, and all unused paper ballots and secrecy envelopes in the large return envelope labeled election day voted paper ballots.

2. The commissioner-in-charge shall post a duplicate copy of the paper ballot audit form next to the posted voting machine results tape.

3. The commissioner-in-charge shall place the large return envelope labeled election day voted paper ballots in the clear plastic zipper bag along with the election results cartridges and deliver the bag to the clerk of court.

AUTHORITY NOTE: Promulgated in accordance with R.S. 18:49.1, R.S. 18:564, R.S. 18:565, R.S. 18:1352, R.S. 18:1353, and R.S. 36:742.

HISTORICAL NOTE: Promulgated by the Department of State, Elections Division, LR 39:1056 (April 2013).

§1107. Delivery of "Election Day Voted Paper Ballots" Envelope and Tabulation and Counting of Paper Ballots

A. Election Day Voted Paper Ballots Envelope

1. Upon receipt of the "election day voted paper ballots" envelope on election night, the clerk of court or his designee shall deliver the envelope to the parish board of election supervisors or absentee commissioners for tabulation of the election day voted paper ballots.

B. Counting and Tabulating the Votes

1. The paper ballots cast at the polling place shall be counted by the parish board of election supervisors or the absentee commissioners on election night according to the procedures for counting absentee by mail ballots in R.S. 18:1313, R.S. 18:1315, R.S. 18:1316, and the specific procedures provided for herein.

2. A member of the parish board or an absentee commissioner shall remove the paper ballots audit form, the sealed secrecy envelopes containing the voted ballots, the spoiled ballot envelopes, and the unused paper ballots from

the election day voted paper ballots envelope and check to confirm that the paper ballots audit form is correct and matches what is delivered in the election day voted paper ballots envelope. If there are any discrepancies, the board or absentee commissioners shall make a notation of the discrepancy on the original paper ballots audit form and certify by their signature to the accuracy of their notation.

3. Each voted ballot shall be removed from the secrecy envelope and a member of the parish board or an absentee commissioner shall write "ED" for election day and his initials in the space on the ballot directly below the secretary of state's signature so as not to mark on the dark black timing marks on the sides of the ballots and to distinguish the election day paper ballots from the absentee by mail paper ballots.

4. The election day paper ballots shall be segregated from the absentee by mail paper ballots and shall be kept segregated by precinct to be counted and reported by precinct.

5. The parish board of election supervisors or the absentee commissioners may elect to count the election day paper ballots manually or they may use the scanning equipment. The election day paper ballots shall be counted separately from the absentee by mail paper ballots and shall be counted and reported by precinct. The secretary of state shall provide written instructions to assist with the counting of paper ballots by precinct.

6. Upon completion of the counting of the election day paper ballots, a member of the parish board of election supervisors or absentee commissioner shall enter the vote totals from the election day paper ballots for each precinct on a worksheet which shall be signed by the board or absentee commissioners and delivered to the clerk of court for entering of the results.

7. The clerk of court or his designee on election night shall add the vote totals for the election day paper ballots from the worksheet to the vote totals for each precinct in the Department of State's Elections and Registration Information Network (ERIN). The secretary of state shall provide written instructions to assist with the entering of these vote totals.

8. Upon completion of the counting of the election day paper ballots, the voted ballots and secrecy envelopes, the original paper ballots audit form, the spoiled ballot envelopes, and all unused ballots and secrecy envelopes shall be returned to the election day voted ballots envelope and the envelope shall be retained by the registrar of voters in accordance with the procedures for retention of absentee by mail ballots in R.S. 18:1312.

AUTHORITY NOTE: Promulgated in accordance with R.S. 18:1312, R.S. 18:1313, R.S. 18:1315, R.S. 18:1316, R.S. 18:1352, R.S. 18:1353, and R.S. 36:742.

HISTORICAL NOTE: Promulgated by the Department of State, Elections Division, LR 39:1057 (April 2013).

Title 31
ELECTIONS
Part II. Voter Registration
Chapter 1. Registrars of Voters

§101. ERIN Manual

A. The Department of State operates a statewide voter registration computer system for the registration of voters throughout the state, the Elections and Registration Information Network, commonly referred to as "ERIN".

B. The Secretary of State shall provide all registrars of voters with an ERIN Manual to be utilized with respect to the statewide voter registration computer system. This manual shall establish procedures with respect to all records, data, and information required for the registration of voters and the transfer of information to the department. All registrars of voters shall utilize this manual to ensure the proper registration of voters. A uniform cost for the preparation of lists of registered voters shall be included in the manual. Any updates of the manual provided by the department to the registrars of voters shall be incorporated into the manual by each registrar of voters.

C. The ERIN Manual shall be submitted to the Committee on House and Governmental Affairs and the Senate and Governmental Affairs Committee for informational purposes. Both committees shall be kept informed of any changes to the manual.

D. Copies of the ERIN Manual can be viewed at the Department of State, Elections Program, XII United Plaza Building, First Floor, 8585 Archives Avenue, Baton Rouge, LA or at each office of the registrar of voters throughout the state, or at the Office of the State Register.

AUTHORITY NOTE: Promulgated in accordance with R.S. 18:18, R.S. 18:31, and R.S. 36:742.

HISTORICAL NOTE: Promulgated by the Department of State, Elections Division, LR 34:704 (April 2008).

§103. Removal of Registrar of Voters for Cause

A. A proceeding for the removal of a registrar shall be commenced by the state board of election supervisors upon the receipt of a resolution from a parish governing authority which includes the following information:

1. accusations of willful misconduct relating to the registrar's official duty, willful and persistent failure to perform his duties, persistent public conduct prejudicial to the administration of the laws relative to the registration of voters that brings the office into disrepute, or conviction of a felony; and

2. favorable adoption of the resolution by at least two-thirds of the membership of the parish governing authority.

B. A proceeding for the removal of a registrar may be commenced by the state board of election supervisors upon the written complaint filed with the state board of election supervisors by one or more natural persons of legal age who reside within the parish served by the registrar whose

removal is sought, which complaint includes the following information:

1. the name and mailing address of each complainant;
2. the name of the registrar whose removal is sought and the parish he serves;
3. the reasons the removal is necessary;
4. a full statement of the facts, commissions or omissions upon which the complaint is based, including the names of persons, dates, places and circumstances, so as to fully inform the registrar as to the factual basis for the complaint. No evidence of any fact not alleged in the complaint shall be brought before the board during the hearing;
5. a clear statement that the complainant is seeking the removal of the registrar from office; and
6. signature of each complainant and verified under oath before a notary or two witnesses.

C. The original resolution or complaint shall be filed with the chairman of the state board of election supervisors by personal delivery to his office, or by regular or certified mail. The chairman of the state board of election supervisors shall provide notice of the resolution or complaint to the accused registrar by certified mail, return receipt requested with restricted delivery to addressee only.

D. Upon receipt of the resolution or complaint, the chairman of the board shall examine each resolution or complaint and may reject the resolution or complaint for filing if he finds that it fails to state a cause of action for removal pursuant to R.S. 18:53 or fails to comply with the filing requirements herein. If the chairman rejects the filing of the resolution or complaint, he shall notify the board, the parish governing authority or complainant and the registrar accordingly. If the chairman accepts the filing of the resolution or complaint, he shall notify the board, the registrar, and either the parish governing authority or the complainant of the scheduled hearing date, time and place, to be set no later than 30 days from receipt of the complaint. All notices to the registrar and parish governing authority or complainant shall be by certified mail return receipt requested with restricted delivery. The notice of hearing shall be in compliance with the provisions of R.S. 49:955.

E. If the chairman rejects the filing of the resolution or complaint, the parish governing authority or complainant may amend the resolution or complaint to state a claim within 10 days of the mailing date shown thereon of the rejection of the filing. If the parish governing authority or complainant fails to file an amended resolution or complaint within the time allowed, the chairman of the board shall dismiss the resolution or complaint.

F. The board may consolidate complaints if they relate to common issues or to the same actions or events.

G. The board shall compile and maintain an official record in connection with each resolution or complaint, containing at a minimum a copy of the following:

ELECTIONS

1. the resolution or complaint, and any board authorized amendments;

2. any written submissions by the parish governing authority, respondent(s), or other interested persons, including any responses authorized by the board;

3. a written report of any investigation conducted or commissioned by the board;

4. copies of all notices and correspondence to or from the board in connection with the resolution or complaint;

5. originals or copies of any tangible evidence produced at any hearing conducted pursuant to these rules;

6. original tape recording produced at any hearing conducted pursuant to these rules and a copy of any hearing transcript; and

7. a copy of any final decision issued by the board.

H. The respondent registrar may file a written answer to the resolution or complaint, notarized or witnessed as provided for herein, prior to the hearing wherein he may admit or deny specifically each of the allegations of the resolution or complaint, and otherwise answer to the resolution or complaint. The board for good cause shown may allow an extension of the time period for answering, if requested by the respondent.

I. Postponements or continuances of any hearing are subject to board approval.

J. Either party or the board, at their cost, may order copies of the transcription of the testimony using the state's uniform fee schedule for copies of public records.

K. The hearing shall be conducted in accordance with the provisions of the Administrative Procedure Act. A complainant, respondent, or other person who testifies or presents evidence at the hearing may, but need not, be represented by an attorney.

L. The board shall render its decision within 10 days after the hearing. All decisions shall comply with the requirements of R.S. 49:958. The decision shall become final 30 days after the mailing date shown thereon, unless a rehearing has been timely requested by either party, or unless the registrar, whose removal has been ordered, files a petition for judicial review by trial de novo in the Nineteenth Judicial District Court before the expiration of the 30-day period.

M. A rehearing may be requested within 10 days from the date of the board's written decision on the grounds listed in R.S. 49:959, and if requested timely, the board shall follow the procedures for rehearing in accordance with R.S. 49:959.

N. If the respondent registrar requests a rehearing, the decision upon rehearing, or denial thereof, shall become final 30 days after the mailing date shown thereon, unless the registrar files a petition for judicial review by trial de novo in the Nineteenth Judicial District Court before the expiration of the 30-day period.

O. All filings and correspondence shall be addressed to State Board of Election Supervisors, Secretary of State,

Department of State, P.O. Box 94125, Baton Rouge, LA 70804-9125.

AUTHORITY NOTE: Promulgated in accordance with R.S. 18:24 and R.S. 18:53.

HISTORICAL NOTE: Promulgated by the Department of State, Board of Election Supervisors, LR 5:328 (October 1979), amended LR 34:1635 (August 2008).

§105. Sale of Voter Registration Lists

A. The Department of State generates voter registration lists through ERIN and establishes guidelines that shall be provided to the registrars of voters for the sale of voter registration lists to the general public.

B. Voter registration lists can either be requested through the department's website www.GeauxVote.com or through a registrar of voters' office. All lists must be paid for in advance based upon an estimate provided by either the department or registrar of voters to the client. All estimates will be signed by the client, unless the estimate is submitted electronically. Checks, money orders and credit cards are the acceptable forms of payment. Payment shall either be given to the department or the Registrar of Voters' office. If the registrar of voters' office receives the payment, the registrar shall fax a copy of the check or money order to the department and mail the check or money order to the department within 48 hours.

C. The department hereby establishes the cost schedules detailed below for the sale of voter registration lists.

1. List of Voter Registrations in PDF Format

Number of Voters	Cost
1-2,000 voters	\$20
2,001 +	\$0.01 x number of voters, not to exceed \$5,000

a. This list can be requested without districts and should contain the following information: parish, registration number, ward, precinct, name, party, age, sex, race, last-vote-date, residence, and mailing addresses. If requested, the list will provide telephone numbers.

b. This list can be requested with districts and should contain the same information above plus the following information: congressional, senatorial, representative, police jury/council, justice of the peace, school board, city district, district court, Public Service Commission, Board of Elementary and Secondary Education, tax ward district, and eight special districts. If requested, the list will provide telephone numbers.

c. This list can be ordered for delivery via electronic mail or CD-ROM. Each duplicate copy of the CD-ROM costs one-fourth the cost of the original.

2. Mailing Labels in PDF Format

Number of Voters	Cost
1-2,000 voters	\$20
2,001 +	\$0.01 x number of voters, not to exceed \$5,000

a. Label formatted pdf files may be ordered with the following information:

- i. voter's name and mailing address only; or
- ii. voter's name, mailing address, ward and precinct.

b. The mailing labels in pdf format can be ordered for delivery via electronic mail or CD-ROM. Each duplicate copy of the CD-ROM costs one-fourth the cost of the original.

3. List of Voter Registrations in Text Format

Number of Voters	Cost
1-2,000	\$20
2,001 +	\$0.01 x number of voters, not to exceed \$5,000

a. The data is in text format.

b. The text format list should provide the following information: parish, name, ward, precinct, party, residence and mailing addresses, sex, race, age, status, registration, date, registration number, last 20 dates voted, and all district information.

c. If requested, the telephone number will be provided.

d. The text format list can be ordered for delivery via electronic mail or CD-ROM. Each duplicate copy of the CD-ROM costs one-fourth the cost of the original.

4. Delivery. The minimum cost for the delivery service shall be \$7.50 per shipment.

5. Special Requests. The prices above apply to requests using the standard criteria. A \$100 per hour programming charge will be added for any "special request." Registrars of voters must check with the information technology section of the department prior to agreeing to a request that does not conform to the standard criteria.

D. The client shall review the list immediately upon receipt. If there is a problem with the list, the client must immediately notify the department or registrar of voters. If the client has a valid reason for seeking a new list or getting a refund, the client has seven days to return the original voter registration list to the department or registrar of voters to receive a new list or a refund. If the original list has been reproduced, no refund will be issued and a new list will be subject to the appropriate costs. If the list was delivered via electronic mail, the list must be deleted prior to receiving a new list or getting a refund. If the reasoning is determined to be justifiable by the department, a new list will be provided or a refund issued.

E. Notwithstanding any provision of this Section to the contrary, a statewide voter registration list may be available electronically to the state chair of a political party recognized pursuant to R.S. 18:441 from the department by subscription agreement. Such statewide voter registration list shall be transmitted electronically on a quarterly basis at a

subscription rate of \$7,500 per year payable to the Department of State.

AUTHORITY NOTE: Promulgated in accordance with R.S. 18:18, R.S. 18:31, 18:441 and R.S. 36:742.

HISTORICAL NOTE: Promulgated by the Department of State, Elections Division, LR 34:704 (April 2008), amended LR 40:372 (February 2014).

§107. Merit Evaluation for the Registrar of Voters

A. The secretary of state hereby designates the director of registration in the Department of State to conduct the annual evaluation of each parish registrar of voters by reviewing the completed evaluation and data submitted by each registrar of voters. The evaluation will consider the timely performance of the registrar's job responsibilities as required by title 18 of the *Louisiana Revised Statutes*. Upon completion of the rating of a registrar by the director of registration, the director of registration shall submit the evaluation to the commissioner of elections for review and either approval or disapproval depending on the information submitted. If the commissioner of elections does not approve the rating given by the director of registration, the registrar will be given the rating recommended by the commissioner of elections. The registrar's evaluation is then submitted to the Department of State Human Resources office. If the registrar receives an "excellent" rating, Human Resources will process the merit increase. If the registrar receives a "satisfactory" rating, Human Resources will not process the merit increase.

B. Annually, the criteria and procedure for the merit evaluation shall be determined by the secretary of state or his designee in conjunction with the Registrar of Voters Association. The secretary of state or his designee shall prepare written instructions and forms to be utilized for the evaluation. Evaluation forms with instructions shall be submitted to the registrars of voters no later than November 1 for completion. The form shall include mandated duties required of the registrar's office in accordance with title 18 of the *Louisiana Revised Statutes* and other applicable laws with input from the Board of Review for Evaluation of the Registrar of Voters Association; however, the form is not intended to be all inclusive of all of the duties mandated in title 18 of the *Louisiana Revised Statutes* and other applicable laws. If a registrar receives an "excellent" rating, the registrar is eligible for a merit increase in January. If a registrar does not receive an "excellent" rating, the registrar will be rated "satisfactory" and is not eligible to receive a January merit increase. Also, if a registrar is a certified elections registration administrator (CERA) and does not receive an "excellent" rating, the registrar is not eligible to receive the 7 percent CERA certification pay increase for that year pursuant to R.S. 18:59.4.

C. The parish registrar of voters will have until December 15 to submit a completed evaluation form with supporting documentation to the Department of State.

D. A written explanation shall be given to any registrar of voters who does not receive an "excellent" rating.

AUTHORITY NOTE: Promulgated in accordance with R.S. 18:18, R.S. 18:55, and R.S. 36:742.

HISTORICAL NOTE: Promulgated by the Department of State, Elections Division, LR 34:705 (April 2008), amended LR 41:759 (April 2015), LR 43:2536 (December 2017).

§109. Merit Evaluations of the Chief Deputy and Confidential Assistant

A. The parish registrar of voters shall perform the annual evaluation of the chief deputy and confidential assistant.

B. Annually, the criteria and procedure for the merit evaluation shall be determined by the Registrar of Voters Association. The association shall prepare written instructions and forms to be utilized for the evaluation. The forms and instructions shall be submitted to the registrars of voters for reviewing the chief deputy and confidential assistant's performance no later than November 1.

C. The parish registrar of voters shall be responsible for evaluating his or her chief deputy and confidential assistant. These evaluations shall be submitted to the Department of State Human Resources office no later than December 15 of each year.

D. A written explanation shall be given to any chief deputy and confidential assistant who does not receive an "excellent" rating.

AUTHORITY NOTE: Promulgated in accordance with R.S. 18:18, R.S. 18:59, and R.S. 36:742.

HISTORICAL NOTE: Promulgated by the Department of State, Elections Division, LR 34:705 (April 2008), amended LR 41:759 (April 2015), LR 43:2537 (December 2017).

§111. Professional Review Committee

A. The Commissioner of Elections shall submit a formal notification to the Professional Review Committee of the Louisiana Registrar of Voters Association of any registrar of voters who does not perform a mandated duty as defined by the annual performance evaluation form.

B. If the department receives a written complaint or email complaint concerning a registrar which does not fall under R.S. 18:53, the department may forward the complaint to the Professional Review Committee.

C. The Professional Review Committee shall investigate the matter and submit a copy of its findings to the board of directors of the Louisiana Registrar of Voters Association no later than 90 days of receipt of a formal notification or complaint. The board of directors shall submit a written copy of the findings and any recommended corrective action to the Commissioner of Elections, the Secretary of State and the State Board of Election Supervisors.

AUTHORITY NOTE: Promulgated in accordance with R.S. 18:18 and R.S. 36:742.

HISTORICAL NOTE: Promulgated by the Department of State, Elections Division, LR 34:705 (April 2008).

§113. Annual Expenditure Report to Parish Governing Authority

A. Annually, the Secretary of State shall provide each parish registrar of voters with an expenditure summary

report for all expenses paid by the state on behalf of each registrar of voters. The report shall be mailed out by the department no later than January 31. This information shall be combined with expenses paid by the parish governing authority into a consolidated report. This report must be submitted annually by the registrar of voters to the parish governing authority, Secretary of State, and parish clerk of court.

AUTHORITY NOTE: Promulgated in accordance with R.S. 18:18, R.S. 36:742, and R.S. 42:283.

HISTORICAL NOTE: Promulgated by the Department of State, Elections Division, LR 34:705 (April 2008).

§115. Repeal Prior Rules and Regulations

A. LAC 31:II.101 promulgated by the Department of Elections and Registration in October of 1998 relating to ERIN (Elections and Registration Information Network) is hereby repealed in its entirety.

AUTHORITY NOTE: Promulgated in accordance with R.S. 18:18 and R.S. 36:742.

HISTORICAL NOTE: Promulgated by the Department of State, Elections Division, LR 34:706 (April 2008).

§117. Prohibition on Accumulation of Annual, Sick and Compensatory Leave for Registrars of Voters

A. Definitions

Duty Status—a registrar of voters shall be available and ready to perform the tasks and responsibilities necessary to fulfill the mandated duties and functions of his/her office, and shall be on-call at all times.

B. The registrar of voters of each parish shall not be eligible to earn or accrue any type of annual or sick leave or paid time off, including compensatory leave, during his/her tenure as the registrar of voters.

C. Registrars of voters shall be considered in "duty status" at all times and therefore will not be required to report absences from the office, take leave for time away from the office or report hours worked to the Department of State for purposes of payroll processing, except for those overtime hours actually worked during early voting for which payment is required and authorized by R.S. 18:1400.8. Each registrar of voters will be solely responsible for the performance of the mandated duties of his/her office. Variances in time and attendance shall not affect the provision of duties and services mandated for each registrar of voters by the Louisiana Constitution and title 18 of the *Louisiana Revised Statutes*.

D. Registrars of voters will remain eligible to receive pay for overtime hours actually worked during early voting as authorized by R.S. 18:1400.8.

E. The current balances of accrued annual, sick and compensatory leave for each registrar of voters that were frozen pursuant to Department of State policy no. 46, "Prohibition on Accumulation of Annual and Sick Leave and Compensatory Time for Registrars of Voters," shall remain frozen pursuant thereto, and no further annual, sick or

compensatory leave shall accrue after the effective date of this Rule. Upon retirement or separation from service, each registrar of voters will be eligible to be paid for up to a combined total of 300 hours of accumulated annual and compensatory leave previously earned pursuant to Department of State policy no. 2, "Attendance and Leave". The leave balances (annual, sick and compensatory) remaining will be reported by the Human Resources Division of the Department of State to the Registrars of Voters Employees' Retirement System for purposes of certification for retirement credit and calculation of retirement benefits, as allowed by the laws and rules governing that system.

F. Any annual, sick and compensatory leave accrued by an employee appointed as registrar of voters in the future shall be carried forward and frozen as of the date of the appointment as the registrar of voters. Upon retirement or separation from service, the registrar of voters will be eligible to be paid for up to a combined total of 300 hours of accumulated annual and compensatory leave. The leave balances (annual, sick and compensatory) remaining will be reported by the Human Resources Division of the Department of State to the Registrar of Voters Employees' Retirement System for purposes of certification for retirement credit and calculation of retirement benefits, as allowed by the laws and rules governing that system.

G. The provisions of this rule shall not be applied in violation of any provision of the Fair Labor Standards Act. Any application of such is strictly prohibited and shall render the applicable portion of the rule null and void.

H. The provisions of this rule apply to all 64 registrars of voters in the state of Louisiana and all registrars of voters that may be appointed in the future.

AUTHORITY NOTE: Promulgated in accordance with R.S. 18:18, R.S. 18:134, R.S. 18:1400.8 and R.S. 36:742.

HISTORICAL NOTE: Promulgated by the Department of State, Elections Division, LR 39:3325 (December 2013).

Chapter 2. Registrars of Voters

§201. Appeal of Merit Evaluation for the Registrar of Voters

A. Submission of a Request for Appeal

1. A registrar of voters who does not receive an "excellent" rating on his or her annual merit evaluation may appeal that rating to the State Board of Election Supervisors.

2. The request for appeal shall be in writing and shall be postmarked or received by the human resources director in the Department of State, or the human resources director's designee, no later than January 31.

3. The request for appeal shall explain the reasons for the request and may provide supporting documentation.

4. If the request for appeal is received timely and contains the required explanation, the human resources director shall submit a notification of the request to the chairperson of the State Board of Elections Supervisors and

to the director of registration within 15 days of receipt of the request for appeal. The notification of request for appeal shall include copies of the written request of the registrar of voters, the original annual merit evaluation, and any supporting documentation provided by the registrar of voters with his or her written request for appeal.

5. The Department of State grievance process shall not be used to review or reconsider evaluations or a procedural violation of the evaluation process.

B. The State Board of Election Supervisors

1. All written requests for appeal of annual merit evaluations that meet the requirements of Subsection A of this Section shall be considered by the State Board of Election Supervisors.

2. The State Board of Election Supervisors shall consist of eight members. The chairperson shall vote only to break a tie. The commissioner of elections shall not vote on the appeal of merit evaluation for the registrar of voters.

3. The chairperson shall convene a meeting of the State Board of Election Supervisors within 15 days of receipt of notification of the request for appeal to discuss the request and render a decision regarding the rating. The registrar of voters who submitted the request for appeal shall be given an opportunity to be heard at the meeting. The board may vote to uphold the "satisfactory" rating or to change the rating to "excellent".

4. The chairperson of the board shall give written notice of the board's decision to the affected registrar of voters, the director of registration, and the human resources director within 10 days.

C. The annual merit evaluation form, the written request for appeal of the registrar of voters, the written notice of the board's decision, and all supporting documentation shall be maintained in the official confidential personnel file of the registrar of voters on file in the Department of State's human resources office.

AUTHORITY NOTE: Promulgated in accordance with R.S. 18:24, R.S. 18:55, and R.S. 36:742.

HISTORICAL NOTE: Promulgated by the Department of State, Board of Election Supervisors, LR 43:2536 (December 2017).

Chapter 3. Voter Registration at Driver's License Facilities

§301. Objective

A. The objective of these rules and regulations is to provide a uniform method of conducting training for any employee authorized to accept voter registration applications at driver's license facilities; to provide for voter registration at driver's license facilities which is impartial, equitable and in the best interest of the citizens of Louisiana; and to provide for an annual review to monitor the program.

AUTHORITY NOTE: Promulgated in accordance with R.S. 18:114.

HISTORICAL NOTE: Promulgated by the Department of Elections and Registration, Commissioner of Elections, LR 16:606 (July 1990), amended LR 20:1372 (December 1994).

§303. Secretary of State

A. It will be the policy of the secretary of state to facilitate the implementation and support of the program for voter registration at driver's license facilities. The secretary of state will coordinate the activities of the parish registrars of voters with the Department of Public Safety and Corrections, and for that purpose, he shall:

1. provide the Department of Public Safety and Corrections with updates on the names and addresses of the parish registrars of voters;
2. provide the Department of Public Safety and Corrections standard notices to be displayed informing the public of the availability of voter registration at driver's license facilities and the eligibility requirements for registration;
3. design in conjunction with the Department of Public Safety and Corrections an electronic voter registration application form and provide paper voter registration applications to be used under emergency and unusual situations;
4. provide training materials to be used for voter registration; and
5. prepare a biannual report as required by the U.S. Election Assistance Commission.

AUTHORITY NOTE: Promulgated in accordance with R.S. 18:114.

HISTORICAL NOTE: Promulgated by Department of Elections and Registration, Commissioner of Elections, LR 16:606 (July 1990), amended LR 20:1372 (December 1994), amended by the Department of State, Elections Division, LR 45:1812 (December 2019).

§305. Parish Registrars of Voters

A. It is the intention of the parish registrars of voters to cooperate fully in the registration of voters at driver's license facilities. In that regard, parish registrars shall:

1. notify the Department of State immediately of any change in the office mailing address of the registrar of voters;
2. upon receipt in the registrar's office of a voter registration application form from any driver's license facility located within his parish, indicate the date received for the application in the Election and Registration Information Network (ERIN) system;
3. determine the parish in which the applicant seeks to register, or if already registered, seeks to change his name or address and, if not his parish, transmit to the appropriate registrar of voters;
4. review such voter registration application form to determine if the applicant is eligible to register to vote in accordance with law; and

5. if there is a change of name or address for a registered voter, process such change and mail a new voter identification card to the voter.

B. The offices of the registrars of voters shall utilize the ERIN system for processing voter registration application forms that are received from the Office of Motor Vehicles (OMV).

AUTHORITY NOTE: Promulgated in accordance with R.S. 18:114.

HISTORICAL NOTE: Promulgated by the Department of Elections and Registration, Commissioner of Elections, LR 16:606 (July 1990), amended LR 20:1373 (December 1994), amended by the Department of State, Elections Division, LR 45:1812 (December 2019).

§307. Authorized Employees at Driver's License Facilities

A. Definition

Authorized Employee or an *Authorized Employee of a Driver's License Facility*—any official or employee of the Department of Public Safety and Corrections or an official or employee of a contractor of the Department of Public Safety and Corrections.

B. Qualifications. An authorized employee at a driver's license facility shall possess the following qualifications:

1. the person shall be an official or employee of the Department of Public Safety and Corrections or an official or employee of a contractor of the Department of Public Safety and Corrections who is employed at a facility for the issuance of Louisiana driver's license or Louisiana identification cards;
2. the person shall have received in-service training;
3. the person shall not participate or engage in any political activity, except to exercise his right as a citizen to express his opinion privately and to cast his vote as he desires;
4. the person shall not have been convicted of any election offense; and
5. the person shall not be a candidate for public office.

C. Duties. An authorized employee at a driver's license facility shall perform the duties listed below.

1. During regular working hours, an authorized employee shall offer voter registration to any U.S. citizen who obtains, renews, or changes the name or address on a Louisiana Driver's License or Louisiana Identification Cards:

a a person who is at least 16 years of age and who is an actual resident of the state, parish, and precinct in which he seeks to register to vote; however, the person will not be eligible to vote until the age of 18;

b a person who is not under an order of imprisonment for conviction of a felony as defined in R.S. 18:2(2), except as provided in R.S. 18:102(A)(1)(b) and R.S. 18:102(A)(1)(c);

c. a person who has not been interdicted after being declared to be mentally incompetent as a result of a full interdiction or is not subject to a limited interdiction where the person's right to vote has been suspended; and

d. a person who is a United States citizen.

2. An authorized employee shall allow an applicant who resides at more than one place in the state with an intention to reside there indefinitely, to choose which residence will be used for registration purposes. However, if the applicant has a homestead exemption, he must register and vote in the precinct in which that residence is located. The exceptions to this provision are:

a. if the person resides in a nursing home (as defined in R.S. 18:333(A)) or in a veterans' home, he may register and vote at the address where the nursing home or veterans' home is located or where he has a homestead exemption; or

b. if the person is a bona fide full-time student attending an institution of higher learning in this state, he may choose as his residence and may register to vote either at the place where he resides while attending the institution of higher learning or at the place where he resides when not attending such institution of higher learning.

3. An authorized employee shall assist any applicant who requests assistance in registering to vote. Such assistance may consist of answering any question the person might have about completing the registration form and shall include assistance in the completion and execution of an application, if requested by the applicant. Additionally, if the person has a physical disability or is unable to read or write English, such assistance shall include:

a. reading the document to the applicant;

b. executing the document by writing what the person dictates or what is said through an interpreter; and

c. allowing the person to sign, or if unable to sign, to make his mark in front of two witnesses who shall also sign.

4. An authorized employee shall require the applicant to provide sufficient information to establish his age, identity, and residency.

5. An authorized employee shall inform an applicant that if he does not declare a political party affiliation that his voter registration application shall indicate "No Party" on the application form.

6. An authorized employee shall ensure that the information provided on the voter registration application is legible and to the best of his knowledge accurate and complete.

7. An authorized employee shall administer any oath required on the voter registration application, as authorized by R.S. 18:114(F)(7).

8. An authorized employee shall inform the applicant that the applicant is not officially registered to vote until the

application has been received and approved by the parish registrar of voters. Upon approval by the registrar of voters, a voter identification card will be mailed to the applicant.

9. An authorized employee shall ensure that the completed electronic voter registration application is transmitted immediately to the Department of State who shall transmit the application daily to the appropriate parish registrar of voters. The date and time of transmission shall automatically be recorded for electronic submissions. An authorized employee shall ensure that a completed paper application is made available to the designated person of the Department of Public Safety and Corrections or its contractor who will be responsible for transmittal to the parish registrar of voters for the parish in which the driver's license facility is located. On the paper voter registration application, the employee shall circle "MV", sign, and date the bottom of each paper application before transmitting to the Department of Public Safety and Corrections or its contractor. For a paper voter registration application, the date of transmittal shall be indicated on the application, and the transmittal shall be made within five working days of the completion of the application form unless the application is accepted within five days before the last day for registration then the application form shall be transmitted at the conclusion of each business day.

10. An authorized employee shall ask any person making a change of name or a change of address on a Louisiana Driver's License or Louisiana Identification Card if such change is to be used for voter registration purposes. If affirmed, such change shall be transmitted in the same manner as a voter registration application form.

11. An authorized employee shall keep any declinations to register to vote confidential, and shall keep confidential the fact that any particular applicant has submitted an application to register to vote at a driver's license facility. All declinations shall be written and signed by the voter. All such applications and declinations to register to vote shall be used only for voter registration purposes.

C. Offenses. No person authorized to accept voter registration application forms shall knowingly, willfully, or intentionally:

1. offer, promise, solicit, or accept money or anything of present or prospective value to secure or influence a vote or registration of a voter;

2. forge, alter, deface, destroy, or remove from proper custodial care any application for voter registration; or

3. intimidate, directly or indirectly, any prospective voter in matters concerning registration or nonregistration.

D. Penalties

1. Any authorized employee who commits an offense as provided herein shall be subject to the penalties provided in R.S. 18:1461, R.S. 18:1461.2, or R.S. 18:1461.4.

2. Any authorized employee who fails to comply with the provisions of law relative to registration at driver's

license facilities shall be subject to the penalties established in R.S. 18:114(H).

AUTHORITY NOTE: Promulgated in accordance with R.S. 18:114, R.S. 18:2(2), R.S. 18:62, R.S. 18:101, R.S. 18:102, R.S. 18:105, R.S. 18:106, R.S. 18:1461, R.S. 18:1461.2, and R.S. 18:1461.4.

HISTORICAL NOTE: Promulgated by the Department of Elections and Registration, Commissioner of Elections, LR 16:607 (July 1990), amended LR 20:1373 (December 1994), amended by the Department of State, Elections Division, LR 45:1812 (December 2019).

§309. Training

A. The Department of State and/or the registrar of voters shall train designated personnel of the Department of Public Safety and Corrections to conduct in-service training. In-service training will be provided to all employees authorized to accept voter registration application forms by these personnel.

B. The training shall include, but shall not be limited to, the following:

1. review responsibility of an authorized employee to offer voter registration;
2. conduct study of the voter registration application with special emphasis on problem areas;
3. discuss information that may be used to establish applicant's age, identity, and residency;
4. discuss assistance that may be provided to applicant;
5. review responsibilities of an authorized employee in ensuring accuracy and legibility of voter registration application and stressing the authorized employee's responsibility for informing the applicant that the applicant is not registered until the parish registrar notifies the applicant of registration;
6. review declination requirements that must be done in writing and signed by the applicant;
7. review transmittal requirements;
8. review offenses; and
9. review penalties established in R.S. 18:114(H) for noncompliance with the provisions of law relative to voter registration at driver's license facilities and in R.S. 18:1461, R.S. 18:1461.2, and R.S. 18:1461.4 relative to voter registration in general.

AUTHORITY NOTE: Promulgated in accordance with R.S. 18:114, R.S. 18:104 -18:106, R.S. 18:1461, R.S. 18:1461.2, and R.S. 18:1461.4.

HISTORICAL NOTE: Promulgated by the Department of Elections and Registration, Commissioner of Elections, LR 16:608 (July 1990), amended LR 20:1374 (December 1994), amended by the Department of State, Elections Division, LR 45:1813 (December 2019).

§311. Review Process

A. An annual meeting between the Department of State and the Department of Public Safety and Corrections shall

be held during the first quarter of each year to monitor any problem areas where changes in rules and regulations or the revised statutes may be necessary. The annual meeting may be discontinued upon mutual agreement when it is felt there is no longer a need to continue to hold such meetings.

AUTHORITY NOTE: Promulgated in accordance with R.S. 18:114.

HISTORICAL NOTE: Promulgated by the Department of Elections and Registration, Commissioner of Elections, LR 16:608 (July 1990), amended LR 20:1374 (December 1994), amended by the Department of State, Elections Division, LR 45:1814 (December 2019).

Chapter 4. Voter Registration at Mandatory Voter Registration Agencies in the State that Provide Public Assistance or Provide State- funded Programs Primarily Engaged in Providing Services to Persons with Disabilities

§401. Objective

A. The objective of these rules is to provide procedures to implement the provisions of the National Voter Registration Act, 42 U.S.C. §1973gg et seq., (NVRA), as interpreted by the United States District Court for the Eastern District of Louisiana in “Scott, et al. v. Schedler, et al.” (docket no. 11-926), in a permanent injunction dated January 23, 2013, at those agencies designated by the state as voter registration agencies which include all offices in the state that provide public assistance and all offices in the state that provide state-funded programs primarily engaged in providing services to persons with disabilities, hereinafter referred to as “mandatory voter registration agencies,” within the intent of 42 U.S.C. §1973gg-5.

AUTHORITY NOTE: Promulgated in accordance with R.S. 18:116, R.S. 36:742, 42 U.S.C. §1973gg et seq., and the Permanent Injunction issued in “Scott, et al. v. Schedler, et al.” (Docket No. 11-926), United States District Court, Eastern District of Louisiana.

HISTORICAL NOTE: Promulgated by the Department of State, Elections Division, LR 39:2798 (October 2013).

§403. Definitions

Department—an office, agency, or other instrumentality of the executive branch that contains mandatory voter registration agencies.

Employee—a full-time or part-time classified or unclassified *employee*, official, or any independent contractor of any mandatory voter registration agency as defined in this Section.

Mandatory Voter Registration Agency or Mandatory Voter Registration Agencies—all offices or agencies in the state that provide public assistance or that provide state-funded programs primarily engaged in providing services to persons with disabilities.

Site—the physical location where voter registration is conducted.

AUTHORITY NOTE: Promulgated in accordance with R.S. 18:116, R.S. 36:742, 42 U.S.C. §1973gg et seq., and the Permanent Injunction issued in “Scott, et al. v. Schedler, et al.” (Docket No. 11-926), United States District Court, Eastern District of Louisiana.

HISTORICAL NOTE: Promulgated by the Department of State, Elections Division, LR 39:2798 (October 2013).

§405. Services Made Available

A. At each mandatory voter registration agency, the following services shall be made available:

1. distribution of the state voter registration application with each application for service or assistance, and with each recertification, renewal, or change of address form relating to such service or assistance, whether the application, recertification, renewal, or change of address form is in paper or electronic format;

2. provide a declaration form with each application, recertification, renewal, or change of address form as described in 42 U.S.C. §1973gg-5(a)(6)(B);

3. provide each applicant who does not decline to register to vote the same degree of assistance with regard to the completion of the voter registration application as is provided by the mandatory voter registration agency with regard to the completion of its own forms, unless the applicant refuses such assistance;

4. accept completed voter registration applications for transmittal to the appropriate parish registrar of voters; and

5. accept any change of name submitted by a registrant which shall serve as a notification of change of name for voter registration unless the registrant states at the time of submitting the change that the change is not for voter registration purposes. The transmittal procedure shall be handled in the same manner as voter registration applications.

B. If the mandatory voter registration agency provides services to a person with a disability at the person’s home, the agency shall provide the services described in Paragraph A at the person’s home.

AUTHORITY NOTE: Promulgated in accordance with R.S. 18:116, R.S. 36:742, 42 U.S.C. §1973gg et seq., and the Permanent Injunction issued in “Scott, et al. v. Schedler, et al.” (Docket No. 11-926), United States District Court, Eastern District of Louisiana.

HISTORICAL NOTE: Promulgated by the Department of State, Elections Division, LR 39:2798 (October 2013).

§407. Declaration Form

A. Each mandatory voter registration agency shall provide a declaration form with each voter registration application that is distributed with each application for service or assistance, and with each recertification, renewal, or change of address form relating to such service or assistance.

B. The declaration form shall include the following, in order:

1. the question:

“If you are not registered to vote where you live now, would you like to apply to register to vote here today?”;

2. boxes for the applicant to check to indicate whether the applicant would like to register to vote or declines to register to vote (failure to check either box being deemed to constitute a declination to register to vote for purposes of providing assistance in completion of the registration application form), together with the statement (in close proximity to the boxes and in prominent type):

“IF YOU DO NOT CHECK EITHER BOX, YOU WILL BE CONSIDERED TO HAVE DECIDED NOT TO REGISTER TO VOTE AT THIS TIME.”

3. if the mandatory voter registration agency provides public assistance, the statement:

“Applying to register or declining to register to vote will not affect the amount of assistance that you will be provided by this agency.”

4. the statement:

“If you would like help in filling out the voter registration application form, we will help you. The decision whether to seek or accept help is yours. You may fill out the application form in private.”

5. the statement:

“For assistance in completing the voter registration application form outside our office, contact _____ at _____.”

a. the first blank shall be filled in with the department’s name and the second blank shall be filled in with the department’s telephone number or other contact information;

6. the statement:

“If completed outside our office, this declaration form and your completed voter registration application form (if you filled one out) should be returned to _____ or _____.”

a. the first blank shall be filled in with the department’s local office physical location and the second blank shall be filled in with the department’s mailing address used to accept applications for service or assistance, recertifications, renewals, and changes of address forms; and

7. the statement:

“If you believe that someone has interfered with your right to register or to decline to register to vote, your right to privacy in deciding whether to register or in applying to register to vote, or your right to choose your own political party or other political preference, you may file a complaint with the Louisiana Secretary of State, Commissioner of Elections, P.O. Box 94125, Baton Rouge, LA 70804-9125, Telephone (toll-free) 1-800-883-2805.”

C. Completed declaration forms shall be retained by the mandatory voter registration agency for at least 24 months.

D. No information relating to a declination to register to vote in connection with an application made at a mandatory voter registration agency may be used for any purpose other than voter registration.

AUTHORITY NOTE: Promulgated in accordance with R.S. 18:116, R.S. 36:742, 42 U.S.C. §1973gg et seq., and the Permanent Injunction issued in “Scott, et al. v. Schedler, et al.” (Docket No. 11-926), United States District Court, Eastern District of Louisiana.

HISTORICAL NOTE: Promulgated by the Department of State, Elections Division, LR 39:2799 (October 2013).

§409. Transmittal of Voter Registration Applications Accepted at Mandatory Voter Registration Agencies

A. Completed voter registration applications accepted by mandatory voter registration agencies shall be transmitted to the appropriate registrar of voters no later than five days after date of acceptance. If a registration application is accepted within five days before the last day for registration, the mandatory voter registration agency shall transmit the completed voter registration application to the appropriate registrar of voters at the conclusion of each business day.

AUTHORITY NOTE: Promulgated in accordance with R.S. 18:116, R.S. 36:742, 42 U.S.C. §1973gg et seq., and the Permanent Injunction issued in “Scott, et al. v. Schedler, et al.” (Docket No. 11-926), United States District Court, Eastern District of Louisiana.

HISTORICAL NOTE: Promulgated by the Department of State, Elections Division, LR 39:2799 (October 2013).

§411. Qualified Employees at Mandatory Voter Registration Agencies

A. Qualifications. In order to perform the services set forth herein, an employee at a mandatory voter registration agency shall possess the following qualifications:

1. be an employee of the mandatory voter registration agency; and
2. have received in-service training on implementation of the NVRA.

B. Duties. Every qualified employee at each mandatory voter registration agency shall comply with and perform all requirements of 42 U.S.C. §1973gg-5 and R.S. 18:116, and shall comply with and perform all duties and responsibilities as set forth in training, manuals, pamphlets, rules and procedures of the secretary of state.

C. Prohibitions. A qualified employee who provides services described in Paragraph A of Section 405 of this Chapter shall not:

1. seek to influence an applicant’s political preference or party registration;
2. display any such political preference or party allegiance;
3. make any statement to an applicant or take any action the purpose or effect of which is to discourage the applicant from registering to vote; or
4. make any statement to an applicant or take any action the purpose or effect of which is to lead the applicant to believe that a decision to register or not to register has any bearing on the availability of services or benefits.

AUTHORITY NOTE: Promulgated in accordance with R.S. 18:116, R.S. 36:742, 42 U.S.C. §1973gg et seq., and the Permanent

Injunction issued in “Scott, et al. v. Schedler, et al.” (Docket No. 11-926), United States District Court, Eastern District of Louisiana.

HISTORICAL NOTE: Promulgated by the Department of State, Elections Division, LR 39:2799 (October 2013).

§413. Review Process

A. Each mandatory voter registration agency shall appoint a qualified employee to serve as the NVRA site coordinator. Each department shall also appoint a NVRA department coordinator. The NVRA site coordinators and NVRA department coordinator shall be responsible for ensuring compliance by each mandatory voter registration agency with the duties and responsibilities provided in 42 U.S.C. §1973gg-5 and R.S. 18:116, and as set forth in training, manuals, pamphlets, rules and procedures of the secretary of state.

B. Each department shall submit the names and contact information of the NVRA site coordinators and NVRA department coordinator to the secretary of state NVRA coordinator. When a change is made, the department shall provide the name and contact information to the secretary of state NVRA coordinator within 10 days.

C. On a quarterly basis, each NVRA department coordinator shall meet with the secretary of state NVRA coordinator to review procedures, forms, and registration data, and to monitor any problem areas where changes in rules or laws may be necessary, or where improvement is needed.

D. Beginning on January 1, 2014, and on a quarterly basis thereafter, the NVRA department coordinator shall submit to the secretary of state NVRA coordinator a concise report that documents the following:

1. the total number of applications for service or assistance, recertifications, renewals, and changes of address relating to such service or assistance received by the department, by program and site;
2. the total number of declaration forms received by the department, by program and site; and
3. the total number of completed voter registration applications received by the department and forwarded to the appropriate registrar of voters, by program and site.

E. Each department shall submit its policies, procedures, and forms currently in use or to be used to implement the provisions of 42 U.S.C. §1973gg-5 and R.S. 18:116 to the secretary of state for approval. The department shall not implement any policies, procedures, or forms until the approval of the secretary of state has been provided to the department.

AUTHORITY NOTE: Promulgated in accordance with R.S. 18:116, R.S. 36:742, 42 U.S.C. §1973gg et seq., and the Permanent Injunction issued in “Scott, et al. v. Schedler, et al.” (Docket No. 11-926), United States District Court, Eastern District of Louisiana.

HISTORICAL NOTE: Promulgated by the Department of State, Elections Division, LR 39:2800 (October 2013).

§415. Training

A. Training on implementation of 42 U.S.C. §1973gg-5 and R.S. 18:116 shall be provided as follows.

1. The secretary of state shall provide annual training to the NVRA department coordinator, NVRA site coordinators, and other personnel designated by the NVRA department coordinator.

2. The NVRA department coordinator shall provide training for new employees described in Section 403 of this Chapter during employee orientation or as part of initial training within 30 days of the date of hire.

3. The NVRA department coordinator shall provide training on no less than an annual basis to all employees described in Section 403 of this Chapter.

B. All training shall include, but shall not be limited to the following:

1. review of responsibilities of employees to distribute voter registration applications and provide declaration forms;

2. discussion of information which may be used to establish an applicant's age, identity, and residency;

3. discussion of assistance that may be provided to an applicant;

4. review of responsibilities in ensuring accuracy and legibility of voter registration applications and stressing responsibility for informing each applicant that the applicant is not registered to vote until the parish registrar of voters notifies the applicant of registration;

5. review of transmittal requirements; and

6. review of prohibitions.

AUTHORITY NOTE: Promulgated in accordance with R.S. 18:116, R.S. 36:742, 42 U.S.C. §1973gg et seq., and the Permanent Injunction issued in "Scott, et al. v. Schedler, et al." (Docket No. 11-926), United States District Court, Eastern District of Louisiana.

HISTORICAL NOTE: Promulgated by the Department of State, Elections Division, LR 39:2800 (October 2013).

§417. List of Mandatory Voter Registration Agencies

A. The secretary of state shall maintain a list of the physical location of each mandatory voter registration agency. Once a year, the secretary of state shall submit the list to the NVRA department coordinator who shall verify the list within 30 days. If there is a change, the NVRA department coordinator shall notify the secretary of state NVRA coordinator within 10 days of the change.

AUTHORITY NOTE: Promulgated in accordance with R.S. 18:116, R.S. 36:742, 42 U.S.C. §1973gg et seq., and the Permanent Injunction issued in "Scott, et al. v. Schedler, et al." (Docket No. 11-926), United States District Court, Eastern District of Louisiana.

HISTORICAL NOTE: Promulgated by the Department of State, Elections Division, LR 39:2800 (October 2013).

§419. Monitoring and Compliance

A. Upon written request of the secretary of state, a department shall prepare a report on NVRA policies,

procedures, and practices in sufficient detail to enable the secretary of state to assess compliance with the NVRA for any mandatory voter registration agency within that department.

B. If, based upon the department's report and such other information as may come to his attention, the secretary of state suspects a violation, deficient practice or noncompliance with the NVRA, the secretary of state may:

1. request additional information from the department;

2. send a compliance letter to the department to correct any violation, deficient practice or noncompliance; or

3. report the suspected violation, deficient practice or noncompliance to the United States Department of Justice.

AUTHORITY NOTE: Promulgated in accordance with R.S. 18:116, R.S. 36:742, 42 U.S.C. §1973gg et seq., and the Permanent Injunction issued in "Scott, et al. v. Schedler, et al." (Docket No. 11-926), United States District Court, Eastern District of Louisiana.

HISTORICAL NOTE: Promulgated by the Department of State, Elections Division, LR 39:2800 (October 2013).

§421. Application of this Chapter

A. This Chapter shall apply equally to all independent contractors, officials, as well as all full-time and part-time classified and unclassified employees of all mandatory voter registration agencies.

AUTHORITY NOTE: Promulgated in accordance with R.S. 18:116, R.S. 36:742, 42 U.S.C. §1973gg et seq., and the Permanent Injunction issued in "Scott, et al. v. Schedler, et al." (Docket No. 11-926), United States District Court, Eastern District of Louisiana.

HISTORICAL NOTE: Promulgated by the Department of State, Elections Division, LR 39:2801 (October 2013).

Chapter 5. Voter Registration at Optional Voter Registration Agencies

§501. Objective

A. The objective of these proposed rules and regulations is to designate additional voter registration agencies as required by R.S. 18:116(A)(2).

AUTHORITY NOTE: Promulgated in accordance with R.S. 18:116.

HISTORICAL NOTE: Promulgated by the Department of Elections and Registration, Commissioner of Elections, LR 21:262 (March 1995).

§503. Designation of Optional Voter Registration Agencies

A. The following offices are hereby designated as voter registration agencies:

1. all public colleges and universities;

2. all public high schools;

3. all private colleges and universities with their permission;

4. all private high schools with their permission; and

5. all municipalities with their permission.

AUTHORITY NOTE: Promulgated in accordance with R.S. 18:116.

HISTORICAL NOTE: Promulgated by the Department of Elections and Registration, Commissioner of Elections, LR 21:262 (March 1995).

§505. Implementation

A. Voter registration at all public colleges and universities will be implemented no later than June 30, 1995. Voter registration at all public high schools will be implemented by no later than August 31, 1995. Implementation will begin for private colleges, universities, high schools, and municipalities upon completion of training after their agreement to participate.

AUTHORITY NOTE: Promulgated in accordance with R.S. 18:116.

HISTORICAL NOTE: Promulgated by the Department of Elections and Registration, Commissioner of Elections, LR 21:262 (March 1995).

Chapter 7. Standards for Effective Non-Partisan Voter Registration and Voter Education

§701. Department of State's Outreach Activities

A. The department shall develop and update material to be utilized in the department's outreach efforts related to voter registration and voter education. In order to convey the department's outreach message, the department will: send out press releases statewide; make public awareness appearances at public meetings and at educational institutions; hold mock elections; conduct elections (e.g., schools, unions, etc.); and participate in media interviews on television programs and radio station programs.

B. With the passage of the Help America Vote Act of 2002 (HAVA), the department will be procuring a new electronic voting system. As a result, the department shall develop educational materials for voters regarding the use of the voting system in the form of instructional brochures and visual presentations. In accordance with the provisions of R.S. 18:563(C), voters are allowed only three minutes to vote on election day. Therefore, these educational materials will be vital to the successful operation of the voting system by the voters and the voting process.

AUTHORITY NOTE: Promulgated in accordance with R.S. 18:18(A)(8)(a), R.S. 18:563(C), Public Law 107-252, and R.S. 49:950 et seq.

HISTORICAL NOTE: Promulgated by the Department of State, Elections Division, LR 31:3164 (December 2005).

§703. Registrars of Voters

A. All registrars of voters are required to participate in the state's annual voter registration week. The department will be required to provide uniform information to registrars of voters to use when conducting certain outreach activities. These activities shall encourage Louisiana citizens to register to vote, to exercise their right to vote, and to encourage participation of voters as election poll workers. In addition, new registrants and existing registrants will receive

information on early voting in person, voting absentee by mail, and voting in person on election day.

AUTHORITY NOTE: Promulgated in accordance with R.S. 18:18(A)(8)(a), Public Law 107-252, and R.S. 49:950 et seq.

HISTORICAL NOTE: Promulgated by the Department of State, Elections Division, LR 31:3165 (December 2005).

§705. Annual Voter Registration Week

A. Under the provisions of R.S. 18:18(A)(8)(b), the official state voter registration week shall be held annually during the last full week which occurs two weeks prior to the close of registration books for the regular fall primary election. Registrars of voters and their employees are an integral part of this process. Representatives from the Louisiana Registrars of Voters Association shall work with the department on the development of the outreach presentation for various groups of participants. The department will annually update registrars of voters on any legislative changes that will affect outreach activities and information.

B. Voter registration outreach activities should be structured to encourage participants who are not registered to vote to register. Participants should be provided the following information:

1. the requirements to register to vote;
2. how to update voter registration information (such as changes in name and address);
3. voter registration deadlines for scheduled election dates;
4. why a registrant may be removed from the voter registration roles; and
5. registration for individuals with disabilities and residents in nursing homes.

C. During the annual voter registration week, the focus of the department and registrars of voters will not only be on voter registration. Registrars of voters will be encouraging registered voters to go out and exercise their right to vote by informing citizens of the following:

1. the registrant's voting rights;
2. the procedures to follow during early voting in person or voting absentee by mail:
 - a. timing of early voting in person and location of early voting for various scheduled election dates during the year;
 - b. timing of voting absentee by mail;
 - c. type of identification required for early voting in person;
 - d. how to vote absentee by mail;
 - e. how to vote if the registrant is in the military or resides overseas;
 - f. special handicap program for individuals with disabilities; and

- g. special program for residents of nursing homes;
- 3. how to vote in person on election day:
 - a. time the polls open and close;
 - b. type of identification required to vote at the polls;
 - c. how individuals with disabilities can vote;
 - d. election dates scheduled during the year; and
 - e. provisional balloting procedures for federal elections only;
- 4. how to cast a vote;
- 5. where to obtain a sample ballot;
- 6. how to use the voting system for that parish;
- 7. encouraging and recruiting voters to serve as election poll workers on election day;
- 8. procedures to follow to file a complaint; and
- 9. procedures to report election fraud or violations.

AUTHORITY NOTE: Promulgated in accordance with R.S. 18:18(A)(8)(a), R.S. 18:18(A)(8)(b), Public Law 107-252, and R.S. 49:950 et seq.

HISTORICAL NOTE: Promulgated by the Department of State, Elections Division, LR 31:3165 (December 2005).

§707. Funding for Outreach Efforts

A. The department shall pay for all outreach efforts conducted by employees of the department. If the department is asked to provide a voting system for a private election, the organization requesting the voting system will be responsible for the payment for the hauling of the voting system.

B. The department shall provide registrars of voters with printed materials on voter registration, voter education, voting rights, and the voting system for use during the annual voter registration week. In addition, the department will advertise the annual voter registration week in the official journal of every parish and issue a statewide public service announcement on the annual voter registration week.

C. Although not mandatory, registrars of voters are encouraged to provide other outreach activities and materials tailored toward their individual communities. The registrar of voters must receive advance written approval by the Commissioner of Elections for the department to pay the expense. If the Commissioner of Elections gives prior approval, the procurement of said service or materials must be procured in accordance with state or parish purchasing procedures and guidelines. The department, upon receipt of the original invoice and supporting documents, shall pay the expense.

AUTHORITY NOTE: Promulgated in accordance with R.S. 18:18(A)(8) and R.S. 49:950 et seq.

HISTORICAL NOTE: Promulgated by the Department of State, Elections Division, LR 31:3165 (December 2005).

§709. Reporting Requirements

A. Report on Voter Education Programs

1. The Commissioner of Elections shall develop and provide a report form to be utilized by the registrars of voters in fulfilling the responsibilities of R.S. 18:18(A)(8). This report form shall require the registrar to provide the following information:

a. a listing of all voter registration and voter education events/activities held by the registrar's office, the location, the amount of time spent on the event/activity, the estimated amount of citizen participation, and any other detailed information describing such event/activity;

b. a listing of any group or organization that requested voter registration information or registration forms and the number of completed voter applications received; and

c. any other relevant voter registration activities.

B. Report Deadlines

1. Registrars of voters must submit the report on voter education programs to the department prior to the close of business on December 15 of each year. If December 15 falls on a weekend or holiday, the report form will be due on the last business work day prior to December 15.

2. The department is required to submit a consolidated annual report on the effectiveness of the state's non-partisan voter registration and voter education programs by January 31 of each year. Information gathered from the annual reports submitted by the registrars of voters, statistical information generated by the statewide voter registration system, and the information generated by the department's outreach division will be utilized to produce this comprehensive report.

3. Under the provisions of R.S. 18:18(8)(a), copies of this comprehensive annual report shall be submitted to the governor, the president of the Senate, and the speaker of the House of Representatives. In addition, the department shall submit copies of this report to the members of the House and Governmental Affairs Committee, members of the Senate and Governmental Affairs Committee, members of the State Board of Election Supervisors, and all registrars of voters.

AUTHORITY NOTE: Promulgated in accordance with R.S. 18:18(A)(8) and R.S. 49:950 et seq.

HISTORICAL NOTE: Promulgated by the Department of State, Elections Division, LR 31:3166 (December 2005).

Title 31 ELECTIONS

Part III. Procurement

Chapter 1. Procurement of Voting System Drayage and Storage

§101. Definition

Drayage—the transporting or cartage of voting equipment and supplies as directed by the Secretary of State.

AUTHORITY NOTE: Promulgated in accordance with R.S. 18:1371 and R.S. 36:742.

HISTORICAL NOTE: Promulgated by the Department of State, Elections Division, LR 34:698 (April 2008).

§103. Revised Statutes

A. These regulations shall be read and interpreted jointly with R.S. 39:1551 et seq.

B. A rule or regulation shall not change any explicit contract provision, commitment, right or obligation of the state, or of a contractor under a state contract in existence on the effective date of that rule or regulation. However, to the extent possible, existing contracts shall be constructed in conformity with these rules and regulations.

C. The bid process for the storage of voting systems shall be performed by the Division of Administration, Office of Facility Planning and Control, except that the Department of State may negotiate for storage space of less than 5,000 square feet in accordance with the provisions of R.S. 18:19.

D. The Office of Facility Planning and Control shall prepare the lease between the department and lessor, and the purchase order shall be prepared by the department for the lease of warehouse storage facilities.

AUTHORITY NOTE: Promulgated in accordance with R.S. 18:19, 1353, 1382, R.S. 39:1643, and R.S. 39:1551 et seq.

HISTORICAL NOTE: Promulgated by the Department of State, Elections Division, LR 34:698 (April 2008).

§105. Invitation for Drayage and Storage Bids, Public Notice, and Bid Opening

A. All contracts for the drayage and storage of voting systems shall be awarded by competitive sealed bidding on a parish or regional basis.

B. If the Secretary of State determines a bid will be awarded on a regional basis for drayage and storage, the criteria shall include but not necessarily be limited to:

1. not more than four parishes in a region;
2. not more than 1,000 voting systems in a region;
3. uniform beginning delivery time with continuous drayage for each parish in a region;

4. uniform beginning return time with continuous drayage for each parish in a region;

5. agreement will first be obtained from each clerk of court for each parish to be included in a regional bid; and

6. a cost savings when bid on a regional basis.

C. Competitive sealed bidding shall be accomplished by sending out written notices to persons known to be able to provide the department's requirements, and by advertising in accordance with R.S. 18:19 and 1371 at least 30 days prior to bid opening.

1. Written notices shall be mailed to those persons who have previously requested an invitation for bids for said parish or parishes, if regional, within the previous four years. The written notices shall be mailed to any parish governing authority included in the bid to be let.

2. The written notices and advertisements shall announce:

- a. the type of contract;
- b. the parish or region for which the contract is required;
- c. the method of acquiring an invitation for bids; and
- d. the date, time, and place of bid opening.

3. Advertisements shall be published in the official journal of the state and in the official journal of the parish or parishes, if regional, for which the contract is required. Advertisements shall be published in a newspaper of general circulation printed in such parish or parishes, if regional, or, if there is no newspaper printed in such parish or parishes, if regional, in a newspaper printed in the nearest parish that has a general circulation in the parish or parishes, if regional, covered by the contract. The department may publish notices in additional journals for maximum coverage.

4. A notice shall be sent to the parish governing authority and the clerk of court of the parish or parishes, if regional, for which the contract is required. The clerk of court shall prominently post such notice in his office.

5. Notification shall also be made available on the department's election webpage at www.GeauxVote.com.

D. The invitation for bids shall contain:

1. complete description of the transportation required;
2. all applicable terms, conditions, and other requirements;
3. types and limits of insurance required;

4. bid and performance bonding requirements; and
5. factors which will be used to determine responsibility and suitability of bidders.

E. Bids shall be publicly opened and read as specified in the invitation for bids in the presence of one or more witnesses. Bidders and the public may be present at any bid opening.

AUTHORITY NOTE: Promulgated in accordance with R.S. 18:19 and 1371, R.S. 36:742, and R.S. 39:1594.

HISTORICAL NOTE: Promulgated by the Department of State, Elections Division, LR 34:699 (April 2008).

§107. Evaluation of Drayage and Storage Bids

A. Drayage bids shall be evaluated based on adherence to the specifications, terms, conditions, and suitability requirements listed in the invitation for bids. The bidder must list any deviations from these specifications, terms, or conditions.

B. Storage bids shall be evaluated based on adherence to the detailed written response to all specifications, any submitted plans, inspection of the proposed site by the department, or an authorized representative, quality, workmanship and suitability of the proposed site for the purposes set forth in the solicitation, including but not limited to the following:

1. location of the proposed space;
2. condition of the proposed site;
3. safety of the proposed site; and
4. timeliness of the availability.

C. The bidder must list any deviations from these specifications, terms or conditions.

AUTHORITY NOTE: Promulgated in accordance with R.S. 36:742 and 1594.

HISTORICAL NOTE: Promulgated by the Department of State, Elections Division, LR 34:699 (April 2008).

§109. Responsibility of Drayage and Storage Bidders

A. The Secretary of State or his designee may make reasonable inquiries to determine the responsibility of prospective contractors. In making his determination, the following factors will be considered:

1. has available the appropriate financial, material, equipment, and personnel resources and expertise, or the ability to obtain them, necessary to indicate the capability to meet all contractual requirements;
2. has a satisfactory record of performance on previous state contracts and with other persons;
3. is qualified legally to contract with the state of Louisiana;
4. has supplied an affidavit of No Felony Conviction attesting to the fact that the proposed contractor and/or the principal officers of a corporation are not currently under an order of imprisonment for any felony conviction or have not been convicted of a lesser election offense under Title 18 or an offense involving an election, voting equipment or an election official; and

5. has reasonably supplied any information requested by the Secretary of State in establishing responsibility.

B. Each bidder who is determined to be non-responsible shall be notified in writing. Such notification shall state all reasons for disqualification, and give each bidder who is proposed to be disqualified, a reasonable opportunity to refute the reasons for disqualification at an informal hearing.

AUTHORITY NOTE: Promulgated in accordance with R.S. 36:742 and R.S. 39:1601.

HISTORICAL NOTE: Promulgated by the Department of State, Elections Division, LR 34:699 (April 2008).

§111. Correction of Withdrawal of Drayage and Storage Bids

A. Obvious errors or errors supported by clear and convincing evidence may be corrected, or bids may be withdrawn, if such correction or withdrawal does not prejudice other bidders and such actions may be taken only to the extent permitted under regulations.

1. Any bid may be withdrawn prior to bid opening.

2. Minor informalities or insignificant mistakes may be waived or corrected if such will not prejudice other bidders (i.e., if the effect on price, quantity, quality, delivery, or contractual conditions is not significant). The Secretary of State may waive any informalities or allow corrections by bidders if it is in the best interest of the state of Louisiana.

AUTHORITY NOTE: Promulgated in accordance with R.S. 36:742 and R.S. 39:1594(F).

HISTORICAL NOTE: Promulgated by the Department of State, Elections Division, LR 34:700 (April 2008).

§113. Drayage Bid Guaranty and Bond

A. If specified in the invitation for bids, a bond, certified check, or money order payable to the Department of State in the amount of 5 percent of the bid must accompany each bid submitted.

B. If a bidder withdraws his bid after bid opening, without complying with LAC 31:III.111, or fails to execute a contract within 20 days of request, the bid bond or other security shall be forfeited and deposited into the Department of the Treasury as income not available.

AUTHORITY NOTE: Promulgated in accordance with R.S. 18:1371, R.S. 36:742, and LAC 34:I.523.

HISTORICAL NOTE: Promulgated by the Department of State, Elections Division, LR 34:700 (April 2008).

§115. Drayage Performance Bond

A. If specified in the invitation for bids, the bidder awarded the contract must submit a performance bond or letter of credit in the penal sum of one and one-half times the contract price made payable to the Department of State.

B. The performance bond shall be written by a surety or insurance company currently on the U.S. Department of the Treasury Financial Management Service list of approved bonding companies which is published annually in the *Federal Register* or by a Louisiana domiciled insurance company with at least an A-rating in the latest printing of the A.M. Best's Key Rating Guide.

C. If a contractor fails to perform in accordance with contractual obligations, the contractor forfeits the performance bond.

AUTHORITY NOTE: Promulgated in accordance with R.S. 36:742, R.S. 38:2219, and R.S. 39:1581.

HISTORICAL NOTE: Promulgated by the Department of State, Elections Division, LR 34:700 (April 2008).

§117. Forfeiture of Bonds for Drayage

A. Actions by bidders causing forfeiture of bonds as stated in §113 and §115 herein shall be cause for removal of said bidders from the department's bid list and will support a determination of non-responsibility for the bidder(s) and its principals for a period of three years.

AUTHORITY NOTE: Promulgated in accordance with R.S. 36:742 and R.S. 39:1581.

HISTORICAL NOTE: Promulgated by the Department of State, Elections Division, LR 34:700 (April 2008).

§119. General Guaranty for Drayage

A. Contractor agrees:

1. to maintain all insurance required in the invitation for bids during the term of the contract;

2. to pay all taxes, permits, licenses and fees;

3. to give all notices and comply with all laws, ordinances, rules and regulations of each city and/or town in the parish in which the contractor is performing his duties, and of the state of Louisiana;

4. to protect the state from loss in case of an accident or mishandling by contractor's employees; and

5. to make available the equipment, labor, insurance, etc., for drayage of voting machines at times other than for elections. Prices of the above mentioned to be negotiated between the contractor and department or to be determined by competitive bidding in accordance with small purchase provisions of the procurement code and subsequent applicable executive orders.

AUTHORITY NOTE: Promulgated in accordance with R.S. 36:742 and R.S. 39:1581.

HISTORICAL NOTE: Promulgated by the Department of State, Elections Division, LR 34:700 (April 2008).

§121. Award of Drayage and Storage Contracts

A. All contracts shall be awarded to the lowest responsive and responsible bidder within 30 days of bid opening, unless more time is needed by the department to investigate suitability and the bidder is notified accordingly.

1. A responsive bidder means a person who has submitted a bid which conforms in all substantive respects to the invitation for bids, including the specifications set forth in the invitation.

2. The award shall be made by unconditional acceptance of a bid without alteration or correction, except as authorized in §111.

B. If a bidder who is the lowest responsive and responsible bidder declines to accept the contract, the award may be made to the next lowest bidder or the solicitation

may be canceled and re-advertised if it is determined to be in the best interest of the state. Any bidder who has declined to accept the contract previously offered shall be ineligible to bid on the subsequent solicitation. A bidder who declines a contract or fails to produce an acceptable performance bond may also be debarred from future bidding.

C. If a bidder who is the lowest bidder fails to meet all criteria as a responsive and/or responsible bidder, the award may be made to the next lowest bidder who meets all criteria as a responsive and responsible bidder or the solicitation may be canceled and re-advertised if it is determined to be in the best interest of the state.

D. In the case of "tie bids," award shall be made in a manner that will discourage future "tie bids." A written justification for the determination of award must be made by the Secretary of State.

E. In-state bidders shall be preferred to out-of-state bidders on a reciprocal basis when there is a tie bid.

AUTHORITY NOTE: Promulgated in accordance with R.S. 36:742, R.S. 39:1594 and 1595.1.

HISTORICAL NOTE: Promulgated by the Department of State, Elections Division, LR 34:700 (April 2008).

§123. Rejection of Drayage or Storage Bids; Cancellation of Drayage or Storage Solicitations

A. The Secretary of State reserves the right to reject any and all bids when it is in the best interest of the state of Louisiana.

1. Reasons for rejecting a bid include, but are not limited to:

a. a determination of non-responsibility of a bidder(s); or

b. the bid is not responsive (i.e., it did not meet specifications or comply with terms and conditions).

2. Reasons for canceling a solicitation include, but are not limited to:

a. the department no longer requires the service;

b. bids received exceeded budgeted funds or were determined by the department to be unreasonable;

c. the solicitation was flawed (i.e., specifications were not complete or were ambiguous);

d. there is reason to believe that the bids received may have been collusive; or

e. there is inadequate competition indicated by low response to the solicitation.

B. When bids are rejected or a solicitation is canceled, written notices shall be given to the bidders, giving the reasons for the rejection or cancellation.

C. When a solicitation is canceled, where appropriate, bidders will be given the opportunity to bid on the new solicitation.

AUTHORITY NOTE: Promulgated in accordance with R.S. 36:742, R.S. 39:1581 and 1599.

HISTORICAL NOTE: Promulgated by the Department of State, Elections Division, LR 34:701 (April 2008).

§125. Emergency Drayage Procurements

A. The Secretary of State or his designee may declare that an emergency situation exists when:

1. property is subject to loss or destruction as a result of an accident or natural disaster within 30 days of an election;
2. the functioning of the department will be threatened; or
3. the health and safety of any person is threatened.

B. Every effort shall be made to obtain bids from three or more bidders. Bids shall be solicited from bonded, insured draymen or lessors currently under contract with the department.

1. If time permits, written quotations shall be solicited.

2. If time does not permit, telephone quotations shall be solicited.

C. The Secretary of State shall make a written determination stating the basis for the declaration of an emergency, the procedure used prior to selecting a contractor, and the basis for awarding to a particular contractor.

D. The Secretary of State shall keep all records relating to emergency procurements at least three years after the Legislative Auditor's Office have completed their audit of the department for the fiscal year in question.

AUTHORITY NOTE: Promulgated in accordance with R.S. 36:742 and R.S. 39:1598.

HISTORICAL NOTE: Promulgated by the Department of State, Elections, LR 34:701 (April 2008).

§127. Collusive Bidding or Negotiations of Drayage or Storage Contracts

A. The attorney general shall be notified in writing whenever collusion is suspected among bidders. Such notice shall contain all known facts.

B. All documents involved in a procurement in which collusion is suspected shall be retained for three years after the Legislative Auditor's Office have completed their audit of the department for the fiscal years in question or until the attorney general notifies the department that they may be destroyed, whichever is longer. These documents shall be made available to the attorney general or his designee upon request.

AUTHORITY NOTE: Promulgated in accordance with R.S. 36:742 and R.S. 39:1626.

HISTORICAL NOTE: Promulgated by the Department of State, Elections Division, LR 34:701 (April 2008).

§129. Drayage and Storage Specifications

A. All specifications shall be written so as to promote as much competition as possible.

AUTHORITY NOTE: Promulgated in accordance with R.S. 36:742 and R.S. 39:1581.

HISTORICAL NOTE: Promulgated by the Department of State, Elections Division, LR 34:701 (April 2008).

§131. Drayage Contract Requirements

A. A contract cannot be transferred, subcontracted, or assigned prior to execution of said contract. After execution of the contract, a contractor may assign or subcontract his obligations under the contract only with the written consent of the Secretary of State, which consent shall not be unreasonably withheld.

B. To the extent that a prospective contractor proposes to utilize subcontractors in performing the contract, the prospective prime contractor shall not be considered to be responsible unless recent performance history indicates an acceptable subcontracting system determined by the Secretary of State. All subcontractors must meet the same standards for responsibility, bonds, and insurance as the prime contractor.

C. If a bidder is the lowest responsible and responsive bidder in more than one parish, bidders will be limited to contracting for parishes with an aggregate total of not more than 1,000 voting systems or four parishes. In the event that those numbers are exceeded, the contracts will be awarded in the order in which bids were taken.

D. The term of the contract shall be one year or less with an option to renew for two additional one-year terms. All contracts shall end on December 31.

E. If the holder of multiple drayage contracts fails to perform in accordance with the provisions of any of his contracts, the Secretary of State may cancel any and all contracts with that contractor. In addition, the contractor may be suspended from future bidding.

AUTHORITY NOTE: Promulgated in accordance with R.S. 18:1371, R.S. 36:742 and R.S. 39:1581.

HISTORICAL NOTE: Promulgated by the Department of State, Elections Division, LR 34:701 (April 2008).

§133. Right to Protest Drayage or Storage Contract Award

A. All proceedings herewith shall be carried out in accordance with the Conduct of Hearing Rules set forth in LAC 34:I.Chapter 31.

B. Any bidder may protest a solicitation or an award of a contract to the Secretary of State.

C. In regard to the solicitation of a drayage or storage contract, the protest must be made in writing at least two days prior to the opening of bids.

D. In regard to the award of any contract, a written protest must be made within 14 days after the contract is awarded.

AUTHORITY NOTE: Promulgated in accordance with R.S. 36:742 and R.S. 39:1671.

HISTORICAL NOTE: Promulgated by the Department of State, Elections Division, LR 34:702 (April 2008).

§135. Legal and Contractual Remedies for Drayage and Storage of Voting Systems

A. The Secretary of State or his designee is authorized to settle and resolve any protest prior to court action. If a protest is not resolved by mutual agreement, the Secretary of State or his designee shall, within 14 days, issue a decision in writing. The decision shall:

1. state the reasons for the action taken; and
2. inform the protestant of its right to administrative and judicial review as provided in Part VI of the Procurement Code.

B. Notice of decision shall be furnished immediately to the protestant and any other party intervening.

C. The decision of the Secretary of State or his designee shall be final unless:

1. the decision is fraudulent; or
2. the person has appealed to the Commissioner of Administration in accordance with R.S. 39:1683 and R.S. 39:1685.

D. If a protest is lodged as provided for in these regulations, the department shall not proceed with the solicitation or award, unless the Secretary of State declares in writing that proceeding is necessary to protect the substantial interest of the state. Upon such determination, no court shall enjoin progress under award except after notice and hearing.

E. When a protest is sustained and the protesting bidder should have been awarded the contract but is not, the bidder shall be reimbursed for reasonable costs associated with the solicitation, including bid preparation costs other than attorney's fees. Any administrative determination of such costs shall require approval of the attorney general.

AUTHORITY NOTE: Promulgated in accordance with R.S. 36:742, R.S. 39:1671, R.S. 18:1673 and R.S. 18:1685.

HISTORICAL NOTE: Promulgated by the Department of State, Elections Division, LR 34:702 (April 2008).

§137. Suspension and Debarment of Drayage or Storage Contractor

A. A bidder and its principal officers and agents may be debarred or suspended from consideration for award of contracts during an investigation for probable cause if it is in the best interests of the state.

B. The Secretary of State may suspend or debar a person for cause after notice to the bidder has been given and the bidder has had a reasonable opportunity to respond. A bidder may be suspended if the Secretary of State determines that there is probable cause to believe that the bidder has engaged in any activity to lead to debarment.

1. The period of time for the suspension of a drayage or storage contract shall be a minimum of one complete cycle of bidding in all parishes.

2. The period of time for debarment of a drayage or storage contract shall be a minimum of two complete cycles of bidding in all parishes.

C. Causes for debarment shall be determined in accordance with R.S. 39:1672(C).

D. In addition to the provisions of R.S. 39:1672(C), the Secretary of State may debar a bidder for the following reasons:

1. the bidder has withdrawn a bid after an award, for whatever reason, more than once; or
2. the Secretary of State may declare other specific reasons for suspension or debarment which is in the best interests of the state.

E. The Secretary of State shall notify the debarred or suspended bidder in writing of the decision stating the reasons for the action taken and the amount of time of suspension or debarment. Such notification shall also inform the debarred or suspended bidder's rights to administrative and judicial review.

F. The decision of the Secretary of State or his designee shall be final unless:

1. the decision is fraudulent; or
2. the person has appealed to the commissioner of administration in accordance with R.S. 39:1684.

AUTHORITY NOTE: Promulgated in accordance with R.S. 36:742 and R.S. 39:1672.

HISTORICAL NOTE: Promulgated by the Department of State, Elections Division, LR 34:702 (April 2008).

§139. Repeal Prior Rules and Regulations

A. LAC 31:III.101, 103, 105, 107, 109, 111, 113, 115, 117, 119, 121,123,125,127, 129, 131,133, 135, 141, 143, 145 and 147 previously adopted by the Department of Elections and Registration are hereby repealed in their entirety.

AUTHORITY NOTE: Promulgated in accordance with R.S. 36:742.

HISTORICAL NOTE: Promulgated by the Department of State, Elections Division, LR 34:702 (April 2008).

Chapter 3. Procurement and Certification of Voting Equipment
Subchapter A. Competitive Sealed Bidding

§301. Invitation for Bids, Public Notice, and Bid Opening

A. All voting machines used in the state of Louisiana shall be purchased by the Commissioner of Elections on the basis of public bids and in accordance with the Louisiana Procurement Code contained in Chapter 17 of Title 39 of the Louisiana Revised Statutes of 1959. All bids will be advertised in the official journal of the state of Louisiana in accordance with all applicable statutes and rules.

ELECTIONS

B. Machines bid in Louisiana must be certified in accordance with the provisions of R.S. 18:1361(A).

C. In accordance with R.S. 18:1361(B), bids on machines that have been certified for use in Louisiana will be considered for purchase and subsequent use.

D. The bids will be opened in public session on the date announced in the bid offering.

AUTHORITY NOTE: Promulgated in accordance with R.S. 18:1353(C), R.S. 18:1361, and R.S. 36:662.

HISTORICAL NOTE: Promulgated by the Department of Elections and Registration, Commissioner of Elections, LR 19:176 (February 1993).

§303. Certification of Voting Equipment

A. All mechanical voting machines currently in use in Louisiana and purchased prior to the adoption of these rules shall be considered certified.

B. Voting equipment offered for sale in Louisiana shall be certified according to procedures established in R.S. 18:1361.

C. The commissioner of the Department of Elections and Registration shall establish policies that shall set standards for all electronic voting equipment to be used in the state of Louisiana.

1. The standards shall conform to the requirements of R.S. 18:1355 and R.S. 18:1399 and the requirements and needs of the Louisiana voting public.

2. All certificates, together with any relevant reports, drawings, and photographs, for electronic equipment shall be public record.

AUTHORITY NOTE: Promulgated in accordance with R.S. 18:1353(C), R.S. 18:1355, R.S. 18:1361, R.S. 18:1399, and R.S. 36:662.

HISTORICAL NOTE: Promulgated by the Department of Elections and Registration, Commissioner of Elections, LR 19:176 (February 1993).