

Energy  
Information  
Administration

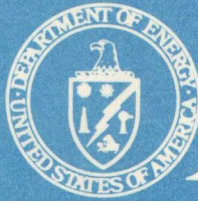

# Annual Report to Congress 1979

---

Volume Three

## Administrator's Message

The Energy Information Administration (EIA) is required by the Federal Energy Administration Act of 1974 (Public Law 93-275) to present short-, mid-, and long-term forecasts of energy supply and demand. In this, the third *Annual Report* of the EIA, that legal requirement is once again met. The short-term forecasts are for 1980 and 1981; the midterm forecasts relate to 1985, 1990, and 1995; and the long-term forecasts are offered for 2000, 2010, and 2020.

Forecasting in these three epochs represents quite different intellectual enterprises, both in the ways in which the results are produced and in the ways they should be used and thought about.

The short-term forecasts are extrapolations of recent experience. They are driven by other forecasts, most notably, chosen projected levels of world oil prices and Data Resources Incorporated (DRI) macroeconomic forecasts for the 1980 and 1981 period. These short-term forecasts may provide a reasonable indication of how energy price and supply will, in fact, turn out in the next year or two—if there are no abrupt oil price changes or other cataclysmic events. But the readers should recall how the year 1979 saw an unanticipated sharp rise in the world oil price, almost doubling in 12 months. This recollection may induce caution about expecting that the numbers in these forecasts will be confirmed in the newspapers of 1981. There are numerous sensitivity analyses that illustrate how some of the forecasted outcomes vary with different chosen levels of world oil price, of economic growth, and of the severity of weather. These sensitivity analyses should enhance the usefulness of the forecasts.

The midterm forecasts explore a range of scenarios in which world oil price is, by assumption, given a high, low, or medium trajectory. The time period (up to 1995) allows mixed opportunities for large changes in stocks of energy-consuming and energy-producing capital equipment; for example, the automobile fleet will turn over nearly completely, but no nuclear plants that are not on order now enter into these forecasts.

The key midterm forecasting method is to assume economic growth rates and world oil prices, and to assume many other future conditions, such as the practical rates of increase in oil exploration and the rates of return that will be demanded for new investment. From this constellation of assumptions, plausible future outcomes of many kinds are derived; projected energy prices and supplies to various consuming sectors are conclusions of this form of analysis.

Notice that many of the most important economic variables are input as assumptions, while others emerge as conclusions. It is the obligation of the writers to be clear about this, but the reader, when finding any point of interest should think carefully, "Is this itself assumed, or is it a conclusion of the analysis?"

The usefulness of a set of forecasts such as these must lie not in their probative value as indications of what the future holds (there are no facts about the future). Their value lies largely in their being a *set of forecasts* different as to some of their key assumptions. The reader can explore how those key factors may influence future patterns of energy supply, demand, production, consumption, and price.

The long-term forecasts are even less to be thought of as revealing what the future holds. At most, we can expect those forecasts to indicate possible ways in which the future might unfold. Future qualities of embryonic technologies are critical to the long-term questions. What will be the costs, the environmental acceptability, the suitability for sectoral demands, of the various incipient technologies whose forms are not yet definite? Apparently, confident knowledge about these matters is not possible decades in advance. Therefore, some of the key driving variables for the long run cannot be known well enough to make trustworthy forecasts.

Such long-term forecasts can be useful, nonetheless, in several ways:

1. Readers may be enabled to think more deeply and more fully about some aspects of the Nation's energy future.
2. Important questions of policy may emerge as tacitly involved in differences among various scenarios.
3. Informational gaps may emerge—gaps which may need filling before policies are irrevocably set.

A final word about this volume of forecasts is in order. Its publication marks the completion of this year's annual renewal of the models and data bases of the Office of Applied Analysis. The same analytical tools used to produce the studies in this volume are applied to studies of various questions of energy economics, technology, and policy as they arise in the course of the year. Thus, the preparation of the set of forecasts offered here serves an important, partly hidden, purpose, but one central to the work of the EIA.

LINCOLN E. MOSES  
*Administrator*

*Rodekoehr*

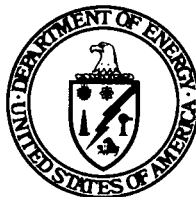

# Annual Report to Congress

1979

---

Volume Three: Projections

**U.S. Department of Energy**  
Energy Information Administration



# Contents

<b>Summary</b> .....	ix
<b>Chapter 1. Energy Projections: The Purposes and Methods</b> .....	1
Goals and Purposes .....	1
The Forecasting Methods and Characteristics .....	3
Sources of Uncertainty .....	4
<b>Chapter 2. International Energy Assessment</b> .....	7
Introduction .....	7
World Oil Price Analysis .....	11
World Oil Markets .....	15
World Energy Market .....	23
Comparison with Other Forecasts .....	31
Summary .....	34
<b>Chapter 3. Short-Term Energy Supply and Demand: 1980–1981</b> .....	35
Introduction .....	35
Forecast Assumptions .....	37
Energy Prices .....	42
Supply and Disposition of Total Energy .....	43
Electricity .....	45
Crude Oil and Petroleum Products .....	51
Balance of Payments Cost of Petroleum Imports .....	61
Natural Gas .....	61
Coal .....	68
Comparison with the ARC 1978 Forecast .....	74
<b>Chapter 4. Midterm Energy Supply and Demand: 1985–1995</b> .....	81
Overview .....	81
Energy Consumption .....	87
Energy Conversion .....	105
Energy Supply—Crude Oil and Natural Gas .....	116
Energy Supply—Coal .....	133
Energy–Economy Interactions .....	138
Comparison to Forecasts in Previous EIA Annual Reports and Elsewhere .....	142
Conclusion .....	151
<b>Chapter 5. Long-Term Energy Supply and Demand: 2000–2020</b> .....	155
Summary of Long-Term Projections .....	155
Overview of the Low, Middle, and High Long-Term Forecasts .....	161
Comparison with Other EIA Forecasts .....	167
Energy Consumption .....	173
Energy Conversion .....	184
Energy Supply .....	197
Concluding Remarks .....	215

<b>Glossary</b> .....	217
<b>Bibliography</b> .....	227
<b>Appendix A. Methodology Overview</b> .....	243
<b>Appendix B. Assumptions and Intermediate Values</b> .....	293
<b>Index</b> .....	347

## FIGURES

2.1	OPEC Pricing Behavior .....	12
2.2	Alternative World Oil Prices, 1960–1995 .....	13
2.3	World Oil Apparent Consumption, 1950–1978 .....	17
2.4	World Oil Production: OPEC and Non-OPEC, 1960–1995 .....	20
3.1	Domestic Utility Generation of Electricity .....	50
3.2	Domestic Demand for Total Petroleum Products .....	57
3.3	Domestic Demand for Motor Gasoline .....	58
3.4	Domestic Demand for Distillate Fuel Oil .....	62
3.5	Domestic Demand for Residual Fuel Oil .....	63
3.6	U.S. Net Imports of Petroleum Products .....	69
4.1	U.S. Energy Consumption and Imports .....	85
4.2	Net Energy Consumption by Sector, 1965–1995 Middle World Oil Price .....	88
4.3	U.S. Economic Activity in the Midterm: Middle World Oil Price .....	89
4.4	U.S. Energy-Economic Indicators in the Midterm: Middle World Oil Price .....	90
4.5	Industrial Energy Fuel Shares by Source: Middle World Oil Price, 1965–1995 .....	92
4.6	Transportation Energy Fuel Shares by Source: Middle World Oil Price, 1965–1995 .....	96
4.7	Distribution of Net Energy by Fuel and End-Use in the Household Sector .....	98
4.8	Residential Energy Fuel Shares by Source: Middle World Oil Price, 1965–1995 .....	100
4.9	Commercial Energy Fuel Shares by Source: Middle World Oil Price, 1965–1995 .....	101
4.10	Distribution of Utility Fuel Consumption: Middle World Oil Price, 1965–1995 .....	107
4.11	Domestic Nuclear Power Capacity, 1965–1995 .....	112
4.12	U.S. Oil and Gas Well Drilling, 1950–1995 .....	118
4.13	U.S. Oil Reserve Additions, 1960–1995 .....	119
4.14	U.S. Natural Gas Reserve Additions, 1960–1995 .....	120
4.15	U.S. Petroleum Liquids Production by Source: Middle World Oil Price .....	121
4.16	U.S. Petroleum Liquids Supply Including Imports: Middle World Oil Price .....	125
4.17	U.S. Natural Gas Production by Source: Middle World Oil Price .....	127
4.18	Production of Coal by Region .....	135
5.1	Comparison of Total Primary Energy Supply and End-Use Consumption .....	157
5.2	U.S. End-Use Energy Consumption by Fuel .....	158
5.3	U.S. Energy Demand by Consuming Sector .....	159
5.4	U.S. Primary Energy Supply and End-Use Consumption Sensitivity to World Oil Price .....	164
5.5	Comparison of 1978 and 1979 Long-Term Projections .....	168
5.6	End-Use Fuel Consumption: Comparison of Long-Term and Midterm Midprice Scenario by Sector, 1995 .....	171
5.7	End-Use Energy Consumption by Sector and Fuel .....	174
5.8	U.S. Utility Demand .....	187
5.9	Prices of Primary Resources Increase with Cumulative Development (1979 Dollars) .....	199
5.10	Total Coal Production by Source .....	201
5.11	Petroleum Liquids Supply .....	203
5.12	Natural Gas Supply by Source .....	206
5.13	Nuclear Fuel Cycle .....	209

5.14	Comparison of Oil and Gas Production from Old and New Technologies .....	211
A.1a	Schematic of the IEES Integrating Framework .....	244
A.1b	Flow of Materials .....	245
A.1c	IEES Regions .....	246
A.1d	Typical Electric Utility Load Duration Curve Showing Relationship of Load to Peak Load as a Function of Time .....	249
A.1e	OPEC Pricing Behavior .....	251
A.1f	OMS Pricing Algorithm .....	253
A.1g	Typical Supply and Demand Curves .....	253
A.2a	STIFS Reference Network (Summary Version) .....	254
A.2a	Interim Short-Term Integrated Forecasting System Reference Network and Variable Names (Detailed Version) .....	255
A.2b	STIFS Functions .....	257
A.2c	STIFS Software—May 1980 .....	258
A.3a	Schematic of the Integrating Framework .....	263
A.3b	Simplified Flow of Materials in the MEFS Integrating Model .....	264
A.3c	MEFS Satellite Models .....	266
A.3d	DOE Regions (MEFS Demand Regions) .....	267
A.3e	MEFS Coal Regions .....	270
A.3f	MEFS Oil Regions .....	271
A.3g	MEFS Natural Gas Regions .....	272
A.3h	Representative MEFS Electric Utility Load Duration Curve—Linear Approximation .....	275
A.3i	PADD Regions (MEFS Refinery Regions) .....	276
A.3j	Typical Supply and Demand Curves .....	277
A.4a	LEAP Network .....	280
A.4b	Residential Sector .....	281
A.4c	Commercial Sector .....	282
A.4d	Industrial Sector .....	283
A.4e	Transportation Sector .....	284
A.4f	Distribution Sector .....	285
A.4g	Electricity Sector .....	286
A.4h	Oil/Gas Sector .....	287
A.4i	Coal Sector .....	288
A.4j	Nuclear Sector .....	290

## TABLES

1.1	Characteristics of the Domestic Forecasts .....	3
2.1	World Economic Growth Rates: History and Projections, Series High, Middle, and Low, 1960–1995 .....	9
2.2	World Oil Price Assumptions, 1979 to 1995 .....	10
2.3	Oil Pricing Scenarios for 1979 Annual Report to Congress .....	10
2.4	World Oil Price Sensitivity Analysis, 1985, 1990, and 1995 .....	14
2.5	Historical World Oil Apparent Consumption, 1950 to 1978 .....	16
2.6	Free World Production of Crude Oil and Natural Gas Liquids Plus Net Centrally Planned Economies Exports .....	18
2.7	OPEC Production Capacity, 1980 to 1995 .....	19
2.8	Free World Oil Production by Country: Midprice Scenario and High–Low Scenario Projection Range, 1978 to 1995 .....	20
2.9	World Oil Apparent Consumption and Production: Projection Series High, Middle, and Low, 1985, 1990, and 1995 .....	22
2.10	Projected World Oil Import Payments: 1990 .....	23
2.11	World Energy Consumption and Fuels Shares: History, 1960 to 1977 .....	26

2.12A	World Energy Consumption and Fuel Shares: History and Midprice Projections, 1985 .....	27
2.12B	World Energy Consumption and Fuel Shares: Midprice Projections, 1990 and 1995 .....	28
2.13	World Energy and Oil Consumption Growth Rates and Energy/Gross Domestic Product (GDP) Ratios: History and Midprice Projections.....	29
2.14	World Energy Consumption and Production: Midprice Projections, 1985, 1990, and 1995 .....	30
2.15	Foreign Nuclear Generating Capacity: Actual and Potential, 1979 to 1995 .....	31
2.16	Sensitivity of Petroleum Demand to World Oil Price Increases .....	32
2.17	Comparison with 1977 and 1978 EIA Annual Report: Midprice Projections, 1990 .....	33
2.18	Free World Energy Forecasts: Comparison of EIA Projections with Other Projections for 1985 to 1990 .....	34
3.1	Energy Supply by Major Sources: Annual 1978-1981 .....	36
3.2	Economic, Price, and Weather Assumptions for Short-Term Energy Projections .....	38
3.3	Short-Term Energy Prices: History and Projections, 1978-1981 .....	40
3.4	Annual Changes in Real GNP and Energy Consumption.....	44
3.5	Quarterly Supply and Disposition of Total Energy .....	46
3.6	Total Energy Demand: Base Case, and Scenario Differentials .....	48
3.7	Quarterly Supply and Disposition of Electricity .....	48
3.8	Electricity Demand: Base Case and Scenario Differentials .....	50
3.9	Quarterly Energy Resources to Produce Electricity.....	52
3.10	Quarterly Supply and Disposition of Petroleum.....	54
3.11	Petroleum Demand: Base Case and Scenario Differentials .....	56
3.12	Quarterly Supply and Disposition of Motor Gasoline.....	58
3.13	Motor Gasoline Demand: Base Case and Scenario Differentials .....	60
3.14	Quarterly Supply and Disposition of Distillate Fuel Oil .....	64
3.15	Distillate Fuel Oil Demand: Base Case and Scenario Differentials .....	64
3.16	Quarterly Supply and Disposition of Residual Fuel Oil .....	66
3.17	Residual Fuel Oil Demand: Base Case and Scenario Differentials .....	66
3.18	Petroleum Imports: Base Case and Scenario Differentials .....	68
3.19	U.S. Gross Oil Imports by Volume and Cost: Actual and Projected for 1978, 1979, 1980, and 1981 ..	70
3.20	Effect of Different Scenarios upon Balance of Payments Cost for Oil Imports in 1980 .....	71
3.21	Quarterly Supply and Disposition of Natural Gas .....	72
3.22	Quarterly Supply and Disposition of Coal .....	74
3.23	Energy Supply and Demand: History and Alternative Projections, Mid Demand/ Mid Supply, 1978-80.....	76
3.24	Energy Supply and Demand: Mid Demand/Mid Supply, 1980; Comparisons with Other Forecasts .....	77
4.1	U.S. Energy Supply/Demand Balance: History and Projections for Three Base Scenarios, 1965-1995 .....	83
4.2	U.S. Energy Prices: History and Projections for Three Base Scenarios, 1965-1995.....	84
4.3	Industrial Energy Consumption and Prices for Three Base Scenarios, 1965-1995 .....	93
4.4	Industrial Energy Consumption and Prices: Compound Annual Growth Rates, Projections for Mid- World Oil Price Scenario, 1965-1995 .....	94
4.5	Transportation Energy Consumption and Prices: History and Projections for Three Base Scenarios, 1965-1995 .....	95
4.6	Transportation Energy Consumption and Prices: Compound Annual Growth Rates, Projections for Middle World Oil Price Scenario, 1965-1995.....	97
4.7	Residential Sector: Impact of Energy Price Increases and the Energy Conservation and Renewable Resource Programs, Projections for Medium World Oil Price Scenario, 1985-1995 .....	102
4.8	Commercial Sector: Impact of Energy Price Increases and the Energy Conservation and Renewable Resource Programs, Projections for Middle World Oil Price Scenario, 1985-1995 .....	102



4.9	Residential Energy Consumption and Prices: History and Projections for Three Base Scenarios, 1965–1995 .....	103
4.10	Commerical Energy Consumption and Prices: History and Projections for Three Base Scenarios, 1965–1995 .....	103
4.11	Energy Consumption and Prices in the Residential Sector: Compound Annual Growth Rates, Projections for Middle World Oil Price Scenario, 1965–1995 .....	104
4.12	Energy Consumption and Prices in the Commercial Sector: Compound Annual Growth Rates, 1965–1995 .....	104
4.13	Electricity Fuel Consumption and Sales by Sector: History and Projections for Three Base Scenarios, 1965–1995 .....	108
4.14	Electric Utility Generation Capacity and Reserve Margins: History and Projections for Three Base Scenarios, 1965–1995 .....	108
4.15	National Average Electricity Prices by Sector: History and Projections for Three Base Scenarios, 1965–1995 .....	109
4.16	Electricity Consumption Fuel Mix: Sensitivity of Projections for 1990 .....	110
4.17	Status of U.S. Nuclear Powerplants as of 31 March 1980 .....	111
4.18	Midterm Nuclear Power Sensitivities: Domestic Projections for 1995 .....	113
4.19	Petroleum Supply/Demand Balance: History and Projections for Three Base Scenarios, 1965–1995 .....	115
4.20	Refinery Product Wholesale Prices: History and Projections for Three Base Scenarios, 1965–1995 .....	115
4.21	Projections of Petroleum and Coal Liquids Production: History and Projections for Three Base Scenarios, 1965–1995 .....	122
4.22	Natural Gas Production and Consumption: History and Projections for Three Base Scenarios, 1978–1995 .....	126
4.23	Natural Gas Prices: History and Projections for Three Base Scenarios, 1965–1985 .....	129
4.24	Sensitivity of Natural Gas Production and Consumption Projections in 1990 for The Middle World Oil Price Scenario .....	131
4.25	Sensitivity of Natural Gas Price Projections in 1990 .....	131
4.26	Coal Production by Region and Mining Method: History and Projections for Three Base Scenarios, 1965–1995 .....	134
4.27	Coal Prices by Region and Coal Type: History and Projections for Three Base Scenarios, 1965–1995 .....	137
4.28	Coal Consumption by End Use Sector: History and Projections for Three Base Scenarios, 1965–1995 .....	137
4.29	Selected Macroeconomic Variables: 1965–1979 Historical and Final Values for Three Base Scenario Projections, 1985–1995 .....	141
4.30	U.S. Energy Supply: 1977, 1978, 1979 Annual Report Projections for 1990 .....	143
4.31	Comparison with Other Projections of 1990 .....	144
4.32	Comparison of 1977, 1978, and 1979 Annual Report Forecasts for 1990 .....	145
4.33	Comparison with Other Projections of 1990 .....	146
4.34	Electricity Generation by Type of Fuel: Comparison with Other Projections for 1990 .....	147
4.35	Midterm Nuclear Power Capacity in Commercial Operation: Comparison of Forecasts, 1985–1995 .....	149
4.36	Coal Consumption by End-Use Sector: Comparison of Alternative Forecasts for 1990 .....	149
4.37	Projections of Natural Gas Supply: Comparison of 1990 Forecasts .....	150
4.38	Projections of Petroleum and Coal Liquids Production: Comparison of 1990 Forecasts .....	151
4.39	1990 Energy Balance Impacts of Major Uncertainties .....	152
4.40	U.S. Energy Prices: Comparison of Alternative Scenarios for 1990 .....	153
5.1	Key Economic Parameters: History and Projections .....	156
5.2	Comparison of EIA, DRI, and Exxon Forecasts for 2000 and EIA and CONAES for 2010 .....	160
5.3	Energy Production/Consumption Trends: History and Projections, Middle Case, 1960–2020 .....	162

5.4	Energy Supply/Disposition Summary: Projection Series Low, Middle, High .....	165
5.5	Summary of Energy Prices: Projection Series Low, Middle, High .....	166
5.6	Energy Supply and Disposition: Comparison of 1978 and 1979 Annual Report to Congress Projections .....	169
5.7	Energy Prices: Comparison of 1978 and 1979 Annual Report to Congress Projections.....	170
5.8	End-Use Fuel Demand: Comparison of Long-Term and Midterm Midprice Case by Sector, 1995 .....	172
5.9	Fuel Consumption by Sector: Projection Series Low, Middle, High .....	175
5.10	Fuel Use by Service Demand and Sector, Projection Series Low, Middle, High .....	176
5.11	Sensitivity of Transportation Service Demand to World Oil Price, 2000–2020 .....	180
5.12	Nuclear Power Forecasts Through the Long Term .....	188
5.13	Electricity Generation by Fuel and Technology: History and Projections, Middle Case .....	189
5.14	Sensitivity of Electricity Fuel Consumption, Generation, and Sales Projections for 2000–2020 .....	190
5.15	Sensitivity of Energy Production to High Capital Equipment Costs of New Technologies, 2000–2020 .....	195
5.16	Coal Supply and Disposition, Middle Case .....	200
5.17	Sensitivity of Coal Production to World Oil Price, 2000–2020 .....	202
5.18	Sources of Liquid Fuels: History and Projections, Middle Case .....	204
5.19	Sensitivity of Petroleum and Synthetic Liquids Production to World Oil Price, 2000–2020 .....	205
5.20	Sources of Gaseous Fuels: History and Projections, Middle Case .....	207
5.21	Sensitivity of Natural Gas Production to World Oil Price, 2000–2020 .....	208
5.22	Average Nuclear Fuel Processing Cost Assumptions by Component .....	210
5.23	Emerging Technology Summary: Projection Series Low, Middle, High .....	216

# Summary

This volume of the Energy Information Administration (EIA) *Annual Report to Congress* presents projections of energy production, consumption, and prices. An analysis of the world oil market provides the basis for three separate assumptions about how the price of internationally traded oil may evolve. Projections are provided for both world and domestic energy markets, based on the three assumed oil price paths. Estimates of world energy production and consumption are provided for 1985, 1990, and 1995. Separate domestic projections are given for three time frames: the short term (1980 and 1981), the midterm (1985, 1990, and 1995), and the long term (2000, 2010, and 2020). The sensitivity of the projections to key assumptions also is investigated.

## THE INTERNATIONAL PROJECTIONS

### Oil Price Uncertainty

The uncertainty surrounding future oil prices requires that energy projections be made for a wide range of possible oil prices. The table below illustrates the range of oil prices, measured in nominal and real prices. Nominal prices are those which consumers face in the marketplace. Real prices are nominal prices adjusted to remove the effect of inflation, and they are given relative to a known price (in this report, relative to 1979 prices).

**World Oil Prices, 1979 and 1990**

World Oil Price Assumptions	Price Case		
	Low	Mid	High
	Real 1979 dollars per barrel		
1979	21.50	21.50	21.50
1990	27.00	37.00	44.00
	Nominal dollars per barrel		
1979	21.50	21.50	21.50
1990	59.00	81.00	96.00

## Fuel Shifts in the World Market

The projections of the world energy market reveal the pattern of how fuel use shifts dramatically during the next decade. Oil consumption as a percent of total energy consumed declines for all countries. The United States is one of a few countries with sufficient coal resources to enable it to make a major substitution of coal for oil. Thus, the United States' portion of total oil consumption in the free world decreases from 36 percent in 1978 to between 29 and 31 percent by 1990. Other countries move toward using more gas and other (hydro, geothermal, and nuclear) energy sources. (See Table S.1.) France is the only major non-Communist country maintaining a strong commitment to continue developing nuclear power, and by 1990, it will be heavily dependent on nuclear energy.

This year's projections are quite different from those in the *Annual Report to Congress, 1978*. World oil and total energy consumption are 24 and 12 percent, respectively, below last year's 1990 midprice projections. Two major differences exist between the two projections. First, this year's *Annual Report* midprice case assumes that in 1990 a barrel of oil will cost \$37 instead of \$20 (1979 dollars), an 85-percent increase. Second, lower economic growth, partially due to the higher oil prices, leads to the lower projections of energy use.

## THE DOMESTIC PROJECTIONS

### Decline in U.S. Oil Imports

Net oil imports, which were 7.8 million barrels daily in 1978, fall until 1985 in all three oil price scenarios. The oil price increases experienced in 1979 are responsible for the initial decrease in U.S. oil consumption and for the slowing of the decline of domestic oil production; these two effects cause the fall in oil imports through 1985. In the middle oil price series, both consumption and production increase slightly after 1985; and imports remain

**Table S.1 World Energy Consumption and Fuel Shares: 1977 and 1990**  
(Quadrillion Btu)

Region or Country	Total Energy Consumed	1977				Total Energy Consumed	1990			
		Fuel Shares (percent)					Fuel Shares (percent)			
		Coal	Oil	Gas	Other		Coal	Oil	Gas	Other
United States .....	77.0	18	49	26	7	89.8	29	36	22	13
Canada .....	8.6	8	45	18	29	11.3	5	35	20	40
Japan .....	15.4	14	76	3	7	23.6	13	55	19	13
Western										
Europe .....	54.0	19	58	13	10	57.3	19	46	16	19
Australia/ New Zealand .....	3.4	34	48	9	9	4.1	33	39	19	9
Total OECD .....	158.4	18	54	19	9	186.0	23	41	19	17
Total non-OECD .....	30.0	19	60	11	10	60.1	21	54	13	12
OPEC .....	6.3	0	70	26	4	15.8	0	68	31	1
Other .....	23.8	24	58	7	11	44.3	29	49	7	15
Total Free World .....	188.4	18	55	17	10	246.1	22	45	18	15

nearly constant through 1995, as shown in Table S.2. The drop in oil imports projected to occur after 2000 is the result of increased production of synthetic liquid fuels, such as shale oil and liquids made from coal and biomass.

In the low price scenario, which assumes imported oil costs constant at \$27 per barrel in 1979 dollars, oil imports grow steadily from their 1985 level. In 1995 of that scenario, the Nation is projected to import almost twice as much oil as in

the midprice scenario and almost three times as much oil as in the high oil price scenario. High crude oil prices stimulate additional domestic oil production and synthetic liquid fuel production, while dampening oil demand.

### Lower Production of Natural Gas

In the middle oil price series, natural gas production declines slowly through the rest of this

**Table S.2 Summary of U.S. Energy Supply Projections (Middle Imported Oil Price Series)**

	History <sup>a</sup>				Projections							
	1965	1973	1978	1979	1980	1981	1985	1990	1995	2000	2010	2020
World Oil Price <sup>b</sup>												
1979 Dollars per barrel	6.00	6.50	15.50	21.50	30.50	30.70	32.00	37.00	41.00	43.00	43.00	43.00
Current Dollars	2.25	4.15	14.77	21.50	33.51	36.85	51.00	81.00	117.00	157.00	256.00	416.00
Domestic Oil												
Quadrillion Btu per Year.....	18.4	22.1	20.7	20.4	20.5	20.1	18.7	19.6	19.4	20.5	20.6	15.0
Million Barrels per Day <sup>c</sup> .....	9.0	11.0	10.3	10.2	10.2	10.0	9.2	9.4	9.6	10.1	10.2	7.4
Net Oil Imports <sup>d</sup>												
Quadrillion Btu per Year.....	5.0	13.0	16.7	16.5	15.0	14.7	12.1	11.7	11.8	13.1	8.4	6.8
Million Barrels per Day.....	2.3	6.0	7.8	7.9	7.0	6.9	5.9	5.7	5.7	6.4	4.2	3.4
Domestic Gas												
Quadrillion Btu per Year.....	15.8	22.2	19.5	19.2	19.0	18.8	18.2	18.7	17.8	16.4	14.6	12.1
Net Gas Imports												
Quadrillion Btu per Year.....	0.4	1.0	0.9	1.2	1.6	1.7	0.8	0.8	0.8	0.7	0.2	0.1
Coal Production												
Quadrillion Btu per Year.....	13.4	14.4	15.0	17.4	17.6	18.3	25.0	29.3	36.7	38.2	49.7	71.6
Million Tons per year.....	527	599	670	776	771	803	1,130	1,343	1,715	1,791	2,401	3,524
Nuclear												
Quadrillion Btu per Year.....	•	0.9	3.0	2.8	2.9	3.4	5.6	8.2	9.6	11.3	18.1	21.8
Total Domestic Supply <sup>e</sup>												
Quadrillion Btu per Year.....	53.7	75.0	78.4	79.3	78.0	78.4	81.6	89.1	96.5	108.1	124.0	143.4

<sup>a</sup>Source for historical data is Volume Two of the EIA *Annual Report to Congress*, Tables 2, 6, 18, 29 and 45.

<sup>b</sup>Cost of imported oil to U.S. refiners. The prices shown for future years are the middle price assumptions used in making these energy projections.

<sup>c</sup>Excludes processing gains.

<sup>d</sup>Excludes imports for the Strategic Petroleum Reserve which began in 1977.

<sup>e</sup>Less than 0.05 quadrillion Btu.

<sup>f</sup>Total supply is the sum of domestic energy production plus net energy imports, excluding imports for the Strategic Petroleum Reserve. The projections for 2000-2020 includes energy supplied outside the marketplace not included in the earlier years.

century. After 2000, depletion of the resource base coupled with increased competition of synthetic gaseous fuels cause natural gas production to fall more rapidly. (See Table S.2.) The reemergence of gaseous fuels made from coal begins in the midterm period (1985 to 1995) and becomes an important fuel in the long term (2000 to 2020).

### Gasoline Trends

Gasoline supplied to the U.S. market falls from its 1978 high of 7.4 million barrels per day to 6.6 million barrels per day in 1981, and to 5.9 million barrels per day (11.4 quadrillion Btu per year) in 1990. In the midprice series, gasoline consumption reaches a low in 1990 and increases slightly by 1995. The short-term and midterm forecasts do not distinguish between motor gasoline and gasohol. To the extent alcohol is substituted for gasoline, gasoline supplied will decrease.

Compared with the average price of goods and services, the price of gasoline increases even more rapidly after 1978 than it did after 1973, the year of the Arab oil embargo. As a result of this price increase, consumers use more fuel-efficient vehicles, and gasoline consumption declines.

### Natural Gas Prices

In the low and middle oil price cases, natural gas prices are projected to be the most rapidly increasing energy prices after 1980. Except for the industrial sector, natural gas does not reach a Btu-equivalent price with petroleum. The transportation sector's requirement for liquid fuels results in the premium price for oil products.

The Natural Gas Policy Act mandates that the higher cost of new gas supplies be passed on to the industrial sector as a surcharge. This surcharge results in industrial gas prices that rise to a Btu-equivalent price that is near the price of high-sulfur residual fuel oil in many parts of the country. In these projections, high-sulfur residual fuel oil is assumed to be the alternate fuel that limits the surcharge. With industrial gas users absorbing a large portion of the higher cost of new gas supplies, other customers, in effect, get a subsidized gas price.

By 1990, gas prices are higher for the average industrial gas user than for the average residential gas user; a reversal of the historical pattern of gas prices. (See Table S.3.) Because the surcharge that

can be placed on industrial gas is limited by the price of a petroleum product—residual fuel oil—higher oil prices mean higher gas prices for industrial users paying the surcharge and lower prices to other gas customers. Thus, in the high oil price scenario, nonindustrial users pay lower prices for gas than in the low oil price scenario. In 1990, the average gas prices projected for industrial and residential users are shown below.

**1990 Natural Gas Prices  
(1979 Dollars per Million Btu)**

	Residential Users	Industrial Users
Low Oil Price Case	4.86	4.06
Middle Oil Price Case	4.65	4.85
High Oil Price Case	4.40	4.91

Although natural gas is projected to remain a bargain, compared with petroleum products, its consumption does not increase. Conservation, stimulated both by law and by higher prices, decreases the demand for gas by existing users. Legal obstacles to new industrial and electric utility fuel customers exploit the price advantage of natural gas over low-sulfur petroleum products.

### The Return to Coal

The domestic projections show the United States rapidly turning to coal to meet its energy needs, given escalating prices for oil and natural gas. In 1978, the ratio of the delivered price of residual fuel oil to the delivered price of steam coal was 1.9; by 1985, the ratio increases to 2.6. The price advantage of coal in the middle and high oil price scenarios increase over time. The ratio of the cost of energy in the form of residual fuel oil to steam coal, both delivered to industrial energy consumers, is 2.9 in the middle oil price case and 3.9 in the high oil price case in 1995. The significant price advantage of coal over other fossil fuels and the restrictions on oil and gas use imposed by the Powerplant and Industrial Fuel Use Act result in industry and electric utilities rapidly returning to coal. Industrial consumption of coal increases from 70 million tons in 1978 to 280 million tons in 1995.

Coal consumption by electric utilities in the short term grows at an annual rate of 7.2 percent to reach 592 million tons per year in 1981. The rate

**Table S.3 Key U.S. Energy Prices: History and Middle Oil Price Series Projections  
(1979 Dollars)**

	History				Projections				
	1965	1973	1978	1979	1980 <sup>b</sup>	1981 <sup>b</sup>	1985	1990	1995
World Oil Price <sup>a</sup> (Dollars per Barrel)	6.00	6.50	15.50	21.50	30.50	30.70	32.00	37.00	41.00
Gasoline <sup>c</sup> (dollars per gallon)	0.69	0.61	0.71	0.87	1.15	1.27	1.36	1.48	1.59
Residential Natural Gas (dollars per million Btu)	2.27	1.98	2.68	3.16	3.34	3.47	3.83	4.65	5.06
Industrial Natural Gas (dollars per million Btu)	0.76	0.75	1.56	—	—	—	3.47	4.85	5.40
Residential Electricity (cents per kWh)	5.1	3.8	4.3	4.8	4.7	4.7	5.4	5.7	5.5

<sup>a</sup>Cost of imported oil to U.S. refiners. The prices shown for future years are the middle price assumptions used in making the energy price projections shown.

<sup>b</sup>The current dollars reported in Chapter 3 are converted to 1979 dollars using the GNP deflators shown in Table 3.2

<sup>c</sup>The price of full service gasoline of the most widely used grade. The gasoline prices do not include the 10 cents per gallon impact of President Carter's proposed oil import fee. The gasoline prices shown in Table 3.3 do include the impact of the oil import fee proposed to result in a 10 cents per gallon increase in gasoline prices, effective May 15, 1980.

— indicates not available.

of growth is 4.6 percent per year from 1981 to 1990, when electric powerplants consume 884 million tons. The rapid growth in coal consumption projected for the short term results from the completion of powerplants started after the oil price increases following the 1973 Arab oil embargo, and from a recovery from the 1978 coal strike.

### The Future of Nuclear Power

Nuclear energy's contribution to the Nation's total primary supply grows from 3.8 percent in 1978 to 9.2 percent in 1990, and then to 14.8 percent in 2020. (See Table S.2.) The contribution of nuclear energy in these projections is significantly lower than those in last year's *Annual Report*, 25 percent lower in 1980 and 13 percent lower in 1990. The revised estimates are based on reduced demand projections for electricity, increased investment costs, continuing problems in waste management, and renewed public anxiety over reactor safety and siting.

A sensitivity analysis is given in Chapter 5 on the impact of a nuclear moratorium consisting of constructing only plants now more than 10 percent complete, and retiring nuclear plants after 30 years of service. The impact on electricity consumers is to increase their electricity cost by 5 percent in 2020. If the same nuclear moratorium assumptions are combined with a scenario that assumes that the cost of most new technologies have been underestimated by half, then electricity prices are 26 percent above the costs projected in a scenario that assumes only high costs for new technologies.

### The Long-Term Shift Away from Oil and Gas

Conventional oil and gas production declines throughout the long-term forecast period; and coal, uranium, and renewable resources combine to satisfy U.S. energy demands. The contribution of coal, uranium, and renewable resources increases from 28 percent of total primary energy in 1978 to 76 percent in 2020. These results imply a major change in the energy market structure toward technologies that are expected to become available in the middle to late 1990's. Supply contributions are expected from synthetics plants, biomass, geothermal and solar sources, and from new coal technologies. New coal technologies, becoming available in the late 1990's for electricity generation, are expected to be more efficient and have less environmental impact than they do today. Both central and end-use renewable resources also supply an increasing share of total primary energy, up from 5 percent in 1978 to 14 percent by 2020. These sources include biomass, solar, ocean thermal, geothermal, hydro, and photovoltaics. Despite these additional sources of energy projected in the long term, the United States never reaches a position of energy self-sufficiency in this period. In the middle and high cases, however, the quantity of imports decreases, so the Nation's vulnerability to arbitrary curtailment of energy imports declines.

### Trends in Energy Consumption

Table S.4 shows the growth rates for electricity consumption and total energy consumption for the

four end-use sectors. All of the projected growth rates are lower than those before the oil embargo period (pre-1973). The growth for electricity falls relative to the growth rate of the economy (GNP growth rate), and, after the turn of the century, it is projected to be nearly equal to the assumed economic growth rate.

For all four sectors of the economy, the projected growth rates of energy consumption are less than the growth rate of the economy. In the past, the transportation sector has been the most rapidly growing sector in energy consumption; in the future, the industrial sector is projected to be the most rapidly growing sector.

**Table S.4 Energy Consumption Annual Growth Rates: History and Projections for the Middle Oil Price Scenario (Percent)**

Sector	1965- 1973	1973- 1978	1978- 1981	1985- 1995	2000- 2020
Electricity.....	7.3	3.2	2.6	3.3	2.0
Residential.....	3.3	-0.1	—	-0.3	-0.3
Commercial.....	4.6	(*)	—	0.7	0.8
Industrial.....	2.9	-0.9	—	2.3	1.5
Transportation.....	5.0	2.1	—	0.7	(*)
GNP.....	3.7	2.5	1.0	2.8	2.0

\*Less than 0.05 percent

# 1. Energy Projections: The Purposes and Methods

## GOALS AND PURPOSES

This volume of the Energy Information Administration's (EIA) *Annual Report to Congress, 1979* presents forecasts of energy production, consumption, and prices. The legislation outlining the requirements for projections specifically calls for an annual report:

"... which includes, but is not limited to ... short-, medium-, and long-term energy consumption and supply trends and forecasts under various assumptions; and to the maximum extent practicable, a summary or schedule of the amounts of mineral fuels resources, nonmineral energy resources, and mineral fuels that can be brought to market at various prices and technologies and their relationship to forecasted demands."<sup>1</sup>

Four separate forecasts and analyses of the projections are provided, as in previous annual reports.

- International energy market projections are for 1985, 1990, and 1995.
- Short-term forecasts for domestic energy markets extend from the most recent data on actual status through the end of 1981.
- Midterm forecasts cover domestic energy markets in 1985, 1990, and 1995.
- Long-term projections consider domestic energy markets to 2020.

These forecasts are based on the assumption that current Government policy continues into the future. The EIA often uses these forecasts as base cases when requested to analyze proposed energy legislation or regulation. Others interested in the energy future may also find them useful base-case projections.

A current EIA study being done at the request of the House of Representative's Subcommittee on Energy and Power, *The Energy Policy Study*,

examines the impact of Federal legislation on the U.S. energy markets. This study involves making energy forecasts for 1990 under scenarios assuming energy policies different from current policy. The projections for 1990, published in this *Annual Report*, are used as the base-case projections for the *Energy Policy Study*. The policy study findings and forecasts are given in a series of *Energy Policy Study* reports, published separately by EIA.

This year's *Annual Report* offers a shorter, more focused presentation than last year's did. Fewer scenarios are examined in detail with emphasis given to variations in future world oil prices. This was done because uncertainties about future world oil prices are the dominant source of uncertainty in domestic market projections. The report does not analyze the impacts of developments in the energy markets on other aspects of American society. In contrast to last year's report, projections are not presented on employment impacts, household energy expenditures, or air emissions due to energy production and consumption.

The forecasts presented in this volume are the product of an annual cycle of gathering energy data and developing an increased understanding of energy markets and their interactions with the entire economy. The EIA computer models are an integral aspect of the methodology used to make energy forecasts. They are updated to reflect changes in the legislation and regulation affecting energy markets. Each energy analyst brings different areas of expertise to developing the forecasts, which are coordinated and synthesized using the computer models.

Dramatic increases occurred in the price of imported oil during the past year. The weighted average international selling price of a barrel of oil has risen from \$13.77 in January 1979 to \$29.62 in February 1980. Great uncertainty exists about future movements of oil prices. Many factors influencing the price of international oil, including noneconomic forces, are analyzed in Chapter 2, "International Energy Assessment." Based on this

<sup>1</sup> Section 57(a)(2), Federal Energy Administration Act of 1974, P.L. 93-275.



analysis, three distinct time paths for the price of international oil are chosen to span a range of possible prices that the United States may have to pay for imported oil in the future.

Projected reactions of the domestic energy markets in the three time frames examined are the subject of this report. Readers can use the forecast in making energy consumption and production decisions, by choosing the forecast closest to their own expectations about the pricing policies of foreign oil producers. For example, decisions as to the amount of insulation to use or the replacement of an inefficient oil boiler with a new, more efficient coal boiler can be addressed.

The analysis of world energy markets reported in Chapter 2 has two themes. One is the exploration of possible future developments in the international oil market, which, in turn, will determine the price of imported oil for Americans. The other is a comprehensive assessment of the world energy scene in 1985, 1990, and 1995.

The short-term forecasts originate from a newly organized team of analysts within EIA. Greater use of EIA energy data is made in this year's short-term forecast than in last year's. Since the fall of 1979, the short-term forecasting and analysis team has been developing and publishing comprehensive energy forecasts.<sup>2</sup> These forecasts, issued quarterly, project energy demand and consumption for a year and a half. Chapter 3, "Short-Term Energy Supply and Demand: 1980-1981," presents a 2-year forecast with the time horizon extended to the end of 1981.

The midterm projections in Chapter 4, "Mid-term Energy Supply and Demand: 1985-1995," are dramatically different from those in last year's report. Imported oil prices, which doubled in 1979, are projected to substantially reduce demands for energy during the 1985-95 time period. The secondary effects of the changes influence the energy markets in unexpected ways. For example, the higher oil prices lead to lower projections of coal consumption than were contained in last year's *Annual Report*. This outcome is the result of lower projections of economic growth, which, in turn, results in lower projections of electricity demand. The lower electricity demand leads to less use of coal in utility plants.

<sup>2</sup> Short-Term Analysis Division, Office of Integrative Analysis, Energy Information Administration, *Short-Term Energy Outlook*, October 1979, DOE/EIA-0202/1, February 1980, DOE/EIA-0202/2 (Washington D.C.: U.S. Department of Energy, 1980).

Since the 1978 *Annual Report*, considerable effort has been devoted to studying the United States' oil production potential. The domestic oil projections in both Chapter 4 and Chapter 5, "Long-Term Supply and Demand: 2000-2020," are much more pessimistic than those made last year: New data on oil resources provide a partial explanation. More significant in explaining the difference, however, are the projection procedures incorporating additional factors that affect the activities of exploring for oil and developing oil fields. The result is lower projections of domestic oil production than previously made by EIA.

This report contains three long-term forecasts of the energy markets, to 2020. The forecast scenarios are logical extensions of the scenarios used for the midterm projections. The 1978 *Annual Report* presented only one EIA long-term forecast, which was an extension of the midprice case of the midterm forecast.

## Scenario Overview

All the projections presented in this report are conditional energy forecasts of a future described by a scenario. The scenarios portray a future setting, and an analysis is done to determine how the energy market may evolve in that setting.

The analysis of the world energy market is built on a number of different projections. There is a different scenario for each projection with variation in the major factors:

- World economic growth
- OPEC<sup>3</sup> oil production capacity
- Non-OPEC energy production
- Disruptions in oil supply.

The range of possible future developments in international energy markets is explored. Based on this analysis, assumptions on the price of imported oil were made for the domestic energy projections.

The short-term forecast is a single forecast for 1980 and 1981. Determinants of demand are the major influence on the energy markets in the short term because energy producers react more slowly to new conditions and are influenced less by transitory events such as weather variations. Sensitivity in the short-term energy outlook to varying assumptions of oil prices, economic activity, and weather is explored in Chapter 3.

Midterm and long-term projections are present-

<sup>3</sup> Organization of Petroleum Exporting Countries.

ed for three scenarios distinguished only by the assumed price path for imported oil. The low-price series assumes that delivered world oil prices, measured without inflation (in constant 1979 dollars), will fall approximately \$2 per barrel from the February 1980 level to a constant \$27. For the mid- and high-price series, the world oil prices in the long-term forecast increase to \$43 and \$60 per barrel, respectively, and remain constant thereafter. In the midterm forecast, world oil prices depend on the level of oil imports; the more oil imported, the higher the price. The oil prices in the midprice series rise moderately until they reach \$41 per barrel in 1995 (in 1979 dollars). Imported oil is assumed to be \$34 per barrel in 1985, if oil imports remain near their 1979 level; however, the price appearing in the midterm forecast is only \$32 per barrel (in 1979 dollars) because imports are projected to decline by 2 million barrels daily. This drop results from a slowing of the decline in domestic oil production and a dramatic decrease in oil consumption. These responses are triggered by the sharp increases in oil prices over their 1978 levels.

The high-price series pessimistically assumes that the rapid increase in imported oil prices experienced during 1979 continues through 1980, continues at a slower pace through the 1980's, and resumes a higher rate again in the early 1990's. Under this scenario, imported oil reaches \$60 per barrel (in 1979 dollars) by 2000.

## THE FORECASTING METHODS AND CHARACTERISTICS

Computer models are fundamental in all aspects of the forecasting methodology. The models help

to assemble systematically large amounts of historical data recording past behavior of the energy markets. Changes in the decisionmaking environment, such as recently enacted legislative restrictions on fuel choice, are represented in the forecasting models. Formal models are crucial tools used to study the many subtle ways that energy markets react to higher energy prices and new laws and regulations. The general characteristic of the methodology is described in this section. Appendix A provides more detail; the Bibliography includes an annotated listing of reports relating to the forecasting process.

The analysis of the international oil market uses a methodology incorporating possible actions of OPEC and responses to oil price changes by non-OPEC energy producers and by oil importers. The dynamic interaction of oil exporters and importers is modeled and the evolution of yearly average oil prices is projected to 1995. The projections of world energy markets are made using a methodology similar to the one used for making the midterm projections of domestic energy markets.

Table 1.1 specifies the major characteristics of the methodologies used to make the three domestic projections presented in the chapters on short-, mid-, and long-term forecasts of energy supply and demand. The short-term forecast is made by first projecting the supplies of domestically produced oil and gas. Nuclear and coal powerplant capacity is estimated based on utility reports to the Federal Government. Next, prices of the various fuels at the point of consumption by major consumers are projected. The consumption levels of the fuels are then projected using these price forecasts along with measures of economic activity taken from an independently derived economic projection.

**Table 1.1 Characteristics of the Domestic Forecasts**

Characteristic	Short Term	Midterm	Long Term
Time Horizon of Projection	Current through 1981	1985, 1990, and 1995	Current to 2020
Treatment of Time	Dynamic, monthly periods, report aggregated to quarters	Combination of static and dynamic techniques	Dynamic, 5-year time increments
Regional Distinctions in the Forecasting Methodology	Single national region with a few exceptions	10 demand regions and a number of supply regions	Single, national demand region with several supply regions
Treatment of Market Forces	Production and consumption can be out of balance--forecasts shortages, energy stocks tracked	Assumes market in equilibrium, no shortages	Assumes market in equilibrium, no shortages
Treatment of Stocks of Energy Equipment	Implicit treatment, trends projected, knowledge of utility plants nearing completion is used.	Explicit treatment, changes in mix projected, new technologies penetration assumed	Explicit treatment, changes in mix projected and penetration of new technologies projected

The projected supply of primary energy is converted into a projection of consumable energy forms such as electricity and gasoline. Electric powerplants and refineries should operate within historical ranges. The supply and demand projections are paired against each other monthly. When demand exceeds supply, an assessment is made to determine if the deficit can be made up from stocks or imports. If the deficit cannot be covered, a possible shortage situation is identified. The forecast reported in Chapter 3 does not reveal shortages under the assumptions used. Excess supply goes into stocks, if building of stocks is believed to be a likely response; otherwise, the production projection is reduced.

The approach used in making the midterm projections is different in several ways from the approach used for making the short-term projections. The midterm forecasts do not consider seasonal variations in energy use or changes in energy stocks. Regional supply and demand projections are made at a number of different prices. The actions of consumers and producers adding to and replacing the stock of equipment that uses or produces energy are simulated. For 1985, 1990, and 1995, the supply and demand possibilities are integrated at equilibrium prices, so that energy consumed balances energy produced at these prices.

Federal legislation, such as the National Energy Act of 1978 (NEA) and the Energy Policy and Conservation Act of 1975, will have its biggest impact in the midterm because capital stock can significantly change in this period. Automobile fuel efficiency will increase as gas guzzlers are replaced. Fuel-efficient automobiles are introduced in response to higher fuel prices and fuel efficiency standards mandated by the Energy Tax Act of 1978, which is one of the five acts that constitute the NEA. Similarly, the combination of legislative pressure and higher oil and gas prices will influence industry and electric utilities to replace oil and gas boilers with coal boilers.

The midterm forecast is a national energy projection developed by making and then aggregating regional forecasts. Little regional detail is included in the midterm projections presented in Chapter 4. Regional projections are developed to capture the diverse forces acting on local energy markets, such as price differences due to transportation costs, which affect fuel choice. The regional projections do not represent official EIA forecasts, but they are given in a published supplement to

this volume. They are supporting calculations to the national projections, and great care must be taken in their interpretation. Some distortions are deliberately introduced in the regional calculations to make the national projections more accurate. For example, powerplants serving one region but physically located in another region are represented as being in the region they serve.

The long-term forecasts cover the period of transition from oil and natural gas as dominant energy sources to coal, nuclear energy, and renewable energy. Regional detail is sacrificed to gain better representation of the time-related factors acting on the energy markets. The methodology used in developing the long-term projections examines the status of the energy markets in 5-year intervals from 1980 to 2020; hence, the forecast period overlaps both the short-term and midterm projection periods. The estimates made for earlier time periods do not reflect all the factors acting on the energy market. For example, some detailed provisions of energy legislation, such as the Natural Gas Policy Act of 1978, are not represented in the long-term projections. The major thrust of the long-term projections is to represent new technologies as they influence the transition from conventionally produced oil and natural gas to replacement fuels.

## SOURCES OF UNCERTAINTY

Many reasons exist why the forecasts in this report are not likely to be realized exactly. These reasons can be grouped into the following categories:

- The scenario assumptions may not be realized.
- The theoretical bases for projection techniques may incorrectly account for the factors affecting the energy markets.
- Errors in the data used affect the projection.
- Errors in the analytic process cause errors in results.

The scenarios used in making the projections assume that future Government actions will be based on policies currently in force and legislation already operative. Changes in implementing the NEA explain some of the differences between the projections in this volume and those in last year's *Annual Report*. The 1978 *Annual Report* assumed electric utilities would select the systems compli-

ance option of the Powerplant and Industrial Fuel Use Act (PIFUA). That action would result in electric utilities reducing their natural gas consumption below the levels shown in the 1990 projections in Chapter 4. This year's scenario assumes that liberal exceptions to the requirement that electric utilities phase out natural gas will occur.

Perhaps the biggest difference between the forecasts shown in this report and their counterparts in last year's report is the assumed high imported oil prices. For example, the midterm projections in last year's report assumed 1995 imported oil costs from \$16.50 to \$31.50 per barrel (measured in 1978 dollars); the range in 1979 dollars is \$18-\$34.50. This year's projections use 1995 imported oil costing from \$27 to \$56 per barrel (in 1979 dollars). The higher oil prices result in lower projections of total energy consumption in all of this year's forecasts.

Another example of a revised scenario definition is the change in the assumption about when the Alaskan Natural Gas Transportation System will make North Slope gas available in the Lower-48 States. Last year's projections assumed the pipeline would be completed by 1985. This year's projections assume it will not be completed until after 1985, but before 1990. Difficulties in arranging for the financing of the delivery system are causing the project to be delayed. This factor necessitates the change in the assumption.

The EIA's projections are based on theories about the behavior of energy producers, converters, and consumers. The short-term projections are dominated by the assumption that past trends can be extrapolated into the immediate future. Energy prices, the economy, and the weather influence these trends. Mid- and long-term projections are developed using different behavioral assumptions about how participants in the energy marketplace interact. Operators of large boilers in both powerplants and industrial facilities are assumed to evaluate equipment and fuel choices using economic criteria. In making the projections, estimates of the costs of environmental controls are

included, and environmental constraints on the location of coal-fired boilers are represented. In contrast to the assumption of economic decision-making used in the industrial sector, demand projections in the residential sector are based on the assumption that behavior exhibited in the past will continue into the future. For example, natural gas is forecasted to remain the economic choice for home heating in most regions, but electricity is projected to continue its historical trend of increasing popularity in those same regions.

Data and analysis errors are also sources of uncertainty in the projections. The EIA publishes extensive documentation of its data collection and analytic methods. Reviews of this documentation by others studying the energy scene are valuable checks for errors. The EIA is conducting an extensive program to validate both the data and analytic procedures used in making its projections. Additional work is planned to develop an understanding of the variations in the forecasts induced by statistical uncertainties in the data.

Alternative projections are made that capture some of the uncertainties in the scenario assumptions. The mid- and long-term projections are sensitive to the assumed imported oil prices, and the experience of the 1970's indicates the difficulty of foretelling oil prices. Therefore, this *Annual Report* provides different projections, given variations in oil prices.

As noted previously, the *Energy Policy Study*, which addresses the impact of Federal legislation on the energy markets, is being conducted in parallel with the analysis leading to the projections reported here. The projections made and reported in the course of the study on energy policy indicate the sensitivity of the midterm projections to variations in policy.

The following chapters include sections comparing the forecasts with earlier EIA projections and similar projections made by other organizations. The comparison of EIA projections with those made by other groups encompasses a combination of different scenarios and different theories used in forecasting.

## 2. International Energy Assessment

### INTRODUCTION

By the end of 1979, the price of crude oil had almost doubled since the beginning of the year. The demand for oil on the world market, the shock of the Iranian cutback of oil production, and the tight production policies of the Organization of Petroleum Exporting Countries (OPEC) greatly contributed to this significant price increase. The United States and other countries, especially the major industrialized countries that are members of the Organization for Economic Cooperation and Development (OECD), compete for the same foreign oil. When oil supplies are tight, as experienced in the spring of 1979, competition for foreign oil increases, and this in turn increases the price. The international market, therefore, influences the U.S. market.

This chapter assesses the international energy situation from the recent past to 1995. For the recent past, the analysis focuses on the supply and demand for oil. For 1985, 1990, and 1995, the analysis assesses possible future trends in world oil prices and provides projections of energy supply and demand balances. The assessment uses a set of alternative assumptions regarding production potential, economic growth, and world oil prices. Initially, three trajectories of future oil prices were synthesized from the results of 12 pricing scenarios. These trajectories are used as assumptions of world oil prices to project both domestic and foreign energy balances. The final oil price analysis, which is based on selected scenarios, uses the new forecasts of domestic and international energy balances, updated levels of non-OPEC production, updated capacities of OPEC production, and assumptions of OPEC production response to price change.

Projection of world oil prices and energy balances are made under the assumption that future prices of world oil will balance future energy supply and demand. These oil prices reflect the substitution of fuels effect; that is, the supply and demand of other energy forms are balanced at market clearing prices. This year's analysis

projects that over the forecast period, energy consumption in the non-Communist world rises between 2.3 and 2.5 percent yearly whereas the demand for petroleum is expected to grow at a rate of 0.9 to 1.7 percent yearly. This growth in consumption is projected to occur when world economic activity is increasing annually at 3.5 to 3.7 percent.

The world oil prices projected in this report are considerably higher than those reported in the Energy Information Administration's (EIA) *Annual Report to Congress, 1978*. For the midprice projection series, the oil price is approximately twice last year's projection for the time frame 1985-95. The Iranian revolution and the related reduction in future oil production estimates for the world as a whole influence this year's projection of higher oil prices. Future interruptions of oil supplies cannot be ruled out given the current political unrest in the Middle East. The possibility of interruptions make it necessary to examine cases with significant increases in OPEC oil prices. Non-OPEC oil producing nations that are selling their oil in a competitive market generally follow the OPEC price setting.

The international energy analysis addresses three projection series of possible energy futures for the world. The projection series are categorized by world oil price, energy production potential, and economic growth. Two additional projection series provide an evaluation of rising prices and a nuclear moratorium. The projection series are summarized as follows:

#### International Energy Projections

Projection Series	Economic Growth	Non-OPEC Energy Production	Remarks
High	High	Low	High oil prices
Middle (or Midprice)	Middle	Middle	Midprice forecast
Low	Low	High	Low oil prices
Low-mid	Middle	Middle	Middle scenario assumptions with low constant oil prices
Low-nuc	Middle	Middle	Middle scenario assumptions with low nuclear

The scenarios, represented by the projection series, capture various ranges of uncertainty inherent in predicting total consumption and price of world energy. The middle, or midprice forecast, combines the midprice estimates of all the various supply and demand assumptions. Each of the two sensitivity series (low-mid and low-nuc) is a variation of the midprice series. The high and low projection series represent the extremes in future OPEC pricing assumptions. Variations in energy supply and economic growth rate assumptions accompany these extremes. The level low-price path was chosen because it is expected to result in energy projections that will be of more interest to the readers of this report than would projections that assumed falling real prices of oil. The low-mid projection series is presented in order to measure the sensitivity of energy consumption to the change in price. That series is a variation of the midprice series, differing only in the assumption of the world oil price.

A nuclear moratorium projection series, low-nuc, represents a "no new nuclear build" policy for all OECD countries, given the public concern with nuclear power. The assumption is that nuclear plants that are under construction and only up to 10 percent completed by year-end 1979 will not be finished.

Series high, middle, and low are comparable to Series B, C, and D in the *Annual Report to Congress, 1978* and are updates of those projections. The largest revisions appear in the projection of higher prices of world oil and lower rates of OPEC production.

The international analysis makes use of U.S. energy forecasts presented in Chapter 4. The high and low scenarios, used for the U.S. analysis, differ from the international scenarios in that they vary from the midprice scenario only in the assumed price levels. The energy supply and economic growth assumptions are the same as for the midprice scenario. The international analysis combines the Puerto Rico and Virgin Islands data and forecasts with the corresponding U.S. figures; the coal used in synthetic manufacture is excluded from the U.S. coal supply and is counted as the resulting oil and gas. Thus, U.S. figures in this chapter may differ slightly from those of Chapter 4.

### **Economic Growth Assumption**

The growth rate of the world economies is the primary factor affecting international energy con-

sumption. Regional projections of real Gross Domestic Product (GDP) growth rates through 1995 are required in the analytic process. This section discusses these assumed growth rates and their derivation.

The historical and projected annual GDP growth rates for selected countries and regions are summarized in Table 2.1. The midprice growth rates provide the base from which the growth rate assumptions are derived for the other two projection series. For the United States, however, the growth rates for the low and high scenarios were assumed to be the same as for the midprice scenario. The values in the table reflect the adjustment because of the effect of the lower and higher world oil price levels.

The projections of base economic growth rates for the free world, 1975-95, are lower than the projections for the 1960-75 period. The average middle scenario growth rate for the free world is projected to drop by 0.5 percentage points from its historical rate of 4.1 percent yearly. (Historical data were available through 1977.) This drop in the world's growth rate is solely accounted for by the projected lower economic growth rates of the OECD countries as compared with the preembargo (1960-72) growth of 4.9 percent per year for OECD countries. The 1977-95 growth rate projections for the major OECD countries are approximately the same as the 1972-77 period; they are not simple extrapolations of this 5-year period. The lower economic growth rates for the 1972-77 period are not only the adjustment of the economies to the oil price shock of 1973-74, but they also represent adjustments to the increasing inflation rates, commodity prices, and economic growth during the early 1970's. However, the low level of economic activity, particularly investment spending and the higher oil prices during this period, adversely affect the future growth of the industrial economies.

The growth rates of the developing countries, OPEC and non-OPEC, are projected to be above the historical growth rates. The higher rates of growth in OPEC and in the middle-income countries accounts for this increased growth. The low-income countries of Asia and Africa are not expected to change from their historical rates. The forces leading to these projected increases are the higher oil prices for the OPEC countries and the expansion of merchandise trade among the developing countries, which reduces the effect of lower economic growth rate of OECD on the developing countries.

## Key Energy Related Assumptions

### Conservation Measures

Energy conservation measures may be categorized into two general groups. The first, "price induced conservation," includes reductions in demand because of changes in retail energy prices. The second, "nonprice energy measures," is the further reduction in demand because of governmental policies that promote conservation. The latter group may be summarized as follows:

- Automobile fuel efficiency standards
- Stringent building standards
- Changes in current regulatory policies (such as special metering for apartments, which alters the pricing mechanism but not the price itself)
- Investment tax credits (and/or taxes to accelerate retirement or nonpurchase of inefficient equipment)
- Demonstration projects
- Loan guarantees
- Appliance efficiency standards

The nonprice conservation policies of five OECD countries were examined to estimate their influ-

ence on energy consumption. These representative countries, totaling about 70 percent of OECD energy consumption (not including the United States) are Canada, the Federal Republic of Germany, France, Japan, and the United Kingdom. Estimates based on these 5 countries were used on a sector by sector basis for the remaining 14 OECD countries because of similarities in energy policies, sector structure, climate, and other factors. For the midprice scenario, total energy savings for OECD is expected to range from 12 quadrillion Btu in 1985 to 14 quadrillion Btu in 1995.

### OPEC Policies

Two key assumptions were made about OPEC's function in the world oil market.

1. OPEC is the residual supplier of world oil demand. As such, its policy will be to expand production capacity 0.8 percent yearly to be able to sustain a production rate of 34.6 million barrels of oil daily by 1990, for the midprice path of world oil.
2. OPEC seeks to maintain a production level somewhat less than its production capacity (currently, production utilization is approxi-

**Table 2.1 World Economic Growth Rates: History and Projections, Series High, Middle and Low, 1960-1995**  
(Annual Percentage Rate)

Region or Country	1960-1972	1972-1977	World Oil Price ... Supply ..... Demand.....	1977-1995		
				Projection Series <sup>a</sup>		
				High Low	Mid Mid	Low High Low
United States .....	3.9	2.6		<sup>b</sup> 2.6	2.7	<sup>b</sup> 2.8
Canada .....	5.4	4.2		3.7	3.4	3.2
OECD Europe.....	4.7	2.7		2.8	2.5	2.4
Japan.....	10.6	4.5		4.5		4.3
Australia/New Zealand.....	4.9	3.1		3.6	3.4	3.2
Total OECD.....	4.9	3.0		3.0	2.9	2.8
OPEC.....		<sup>c</sup> 5.0		6.4	<sup>c</sup> 5.9	5.8
Other <sup>e</sup> .....				5.5	5.1	5.1
World <sup>f</sup> .....		<sup>c</sup> 4.1		3.7	<sup>c</sup> 3.6	3.5

<sup>a</sup>Growth rate projections are based on projections of gross domestic (or national) product valued in 1975 dollars at 1975 exchange rates.

<sup>b</sup>For the U.S. analysis, the growth rates were the same for the high, middle and low scenarios. They are shown here having been adjusted for the high and low price effects by the analytic process. The non-U.S. growth rates reflect specific assumptions of higher growth rates for the high scenario and lower growth rates for the low scenario.

<sup>c</sup>Base year for calculating growth rates is 1975 because data are not available for other years.

<sup>d</sup>Separate historical growth rates for OPEC and other countries are not shown because data are not available.

<sup>e</sup>Other includes South Africa, Israel, and all non-OPEC developing countries.

<sup>f</sup>Excludes Communist countries.

Sources: Historical data for OECD countries based on Organization for Economic Cooperation and Development, *National Accounts of OECD Countries, 1952-1977*, Volume 1. Historical data for OPEC, Other, and World based on International Bank for Reconstruction and Development, *World Development Report, 1979*.

mately 80 percent of capacity). The assumption is that OPEC will raise prices, if necessary, to achieve this goal.

The Centrally Planned Economies (CPE) are represented as net energy traders. For the mid-price series, they are assumed to have a zero balance of net oil trade. For the high and low projection series, they are assumed to be net importers of 1 million barrels per day and net exporters of 1 million barrels per day, respectively. This assumption of the CPE net oil trade is consistent with the scenario definitions of high supply with low oil prices and low supply with high oil prices. This simplified treatment of the CPE is necessary because of the lack of data. (See Appendix B for a comprehensive list of assumptions.)

## Forecasting Procedures and Sources of Uncertainties

The process of making this forecast was accomplished in four basic steps, using analytic tools maintained and operated by the EIA. These tools are described in Appendix A. The four steps are listed below.

1. An initial projection of world oil prices was made. This projection uses previous forecasts of U.S. energy trade, particularly oil imports, and international energy supply and demand functions. The price projections were then made under varying assumptions concerning OPEC production capacity (such as OPEC supply interruptions) and OPEC pricing behavior. Twelve pricing scenarios were examined. From these, three price paths were synthesized representing low, middle, and high pricing assumptions. (See Table 2.2.) Also developed in this step were projected prices as a function of U.S. oil imports.
2. The three assumptions of world oil prices were used in forecasting domestic energy balances. (The domestic analysis is presented in Chapter 4.) The domestic analysis updates the world oil prices, as shown in Table 2.2; U.S. oil imports, using the import price functions developed in Step 1; coal exports; and natural gas imports.
3. The international energy balances were forecast, incorporating the U.S. energy trade and imported crude oil prices determined in Step 2. The international energy balances were also updated to include recent downward estimates in foreign oil production potential.

4. An updated analysis of future world oil prices was then made, using the final world energy balances from Step 3. The updated prices are projected for the 12 scenarios mentioned in Step 1: a middle base case, and 11 alternatives. (See Table 2.3.)

The uncertainty of world oil prices is reflected in the projections, with real prices ranging between \$27 and \$44 per barrel across three projection series by 1990. The 1978-79 supply disruption in Iran is causing a great deal of uncertainty in oil supply and price. The official OPEC prices, as of April 1980, resulted in average delivered prices to the United States of about \$30.30 per barrel, expressed in midyear 1979 dollars.

**Table 2.2 World Oil Price Assumptions, 1979 to 1995**

World Oil Prices	Price Case	High	Mid	Low
	Supply Case Demand Case	Low High	Mid Mid	High Low
<b>Initial Assumptions</b> (real 1979 dollars per barrel)				
1979.....		21.53	21.53	21.53
1985.....		40.00	34.00	27.00
1990.....		45.00	37.00	27.00
1995.....		55.00	40.00	27.00
<b>World Oil Prices Adjusted by Domestic Analysis</b> (real 1979 dollars per barrel)				
1979.....		21.53	21.53	21.53
1985.....		39.00	32.00	27.00
1990.....		44.00	37.00	27.00
1995.....		56.00	41.00	27.00
<b>(nominal dollars per barrel)</b>				
1979.....		21.53	21.53	21.53
1985.....		62.50	51.00	43.00
1990.....		96.50	81.50	59.50
1995.....		160.00	117.50	77.00

**Table 2.3 Oil Pricing Scenarios for 1979 Annual Report to Congress**

Price Scenario	Foreign Demand	Non-OPEC Supply	OPEC Supply	Disruptions <sup>a</sup>
ARC 1.....	M	M	M	no
ARC 2.....	L	H	L	no
ARC 3.....	H	L	M	yes
ARC 4.....	M	M	H	no
ARC 5.....	M	M	L	yes
ARC 6.....	L	L	L	yes
ARC 7.....	H	H	H	no
ARC 8.....	L	H	H	no
ARC 9.....	H	L	L	yes
ARC 10.....	L	L	L	no
ARC 11.....	L	L	H	no
ARC 12.....	H	L	L	no

<sup>a</sup>A disruption scenario consists of a cutback in OPEC production of 2 million barrels per day in each of the years 1983, 1988, and 1993. L = Low, M = Middle, H = High.



The three main projection series postulate different oil prices, economic growth, and supply availability assumptions. The low price projection shows prices remaining at roughly their official OPEC levels of December 1979 (in real terms) through 1995. The middle and high projection series reflect rising oil prices, reaching \$41 and \$56, respectively, by 1995 (stated in 1979 U.S. dollars).

Price uncertainty becomes even greater if either more adverse pricing behavior from OPEC or continued supply disturbances, such as those experienced in Iran in 1978 to 1979, should occur. This uncertainty is reflected in the high price projections series. For OPEC not to expand beyond their current production capacity would also raise prices. Such a decision could raise the midprice forecast from \$37 to roughly \$41 per barrel in 1990.

## WORLD OIL PRICE ANALYSIS

### OPEC Pricing Behavior Assumptions

An analysis of world oil prices is not complete without stating the assumptions concerning the OPEC pricing behavior. The assumptions made in the EIA projection of world oil prices are as follows:

- The percent utilization of production capacity, as shown in Figure 2.1, influences OPEC oil pricing.
- If anticipated demand for OPEC oil in a given forecast year is greater than 80 percent of the sustainable OPEC production capacity, oil prices will then rise in real terms; otherwise, prices remain constant or decline.

Using these behavior assumptions, the resulting price increase (or decrease) is consistent with historic OPEC behavior. The demand for oil may possibly be so strong that the market clearing price for internationally traded oil may be even greater than that indicated by the historic OPEC pricing behavior.

### World Oil Prices

The world oil prices included in the EIA projections are a result of the four steps outlined in the Introduction to this chapter. The price paths given in this report are consistent with OPEC's price setting and capacity utilization behavior for the 1973 to 1979 period. The pricing analysis does not

present any forecasts treating OPEC as a profit maximizer.

The final step of the process to project oil prices is to examine a base case consisting of, (1) the middle scenario assumptions of supply and demand and, (2) 11 alternative scenarios. (See Table 2.3.) These 12 cases reflect a wide range of future price possibilities. The analytic process uses energy supply and demand functions by region and a representation of the OPEC pricing behavior. The following summarizes this process:

- Determine the percentage change in the price of world oil based upon OPEC pricing behavior assumptions, mentioned above, using the most recent historical price as a starting point. (See Figure 2.1.)
- Determine the world demand for OPEC oil under the OPEC-administered price floor, using both the elasticities of oil supply and demand and the elasticities of economic activity. These elasticities are derived from the energy model IEES which is described in the Appendix.
- When the demand for OPEC oil requires OPEC to produce in excess of its maximum sustainable capacity, increase oil prices until the market is cleared of any excess demand and OPEC production is within its capability.
- Once a price is consistent with historical OPEC pricing behavior and clears the market of any excess demand, repeat the pricing procedure for the next forecast year. Use the most recent forecasted price as the starting point.

Figure 2.2 presents the projections of world oil prices for the base case and the 11 alternative cases, with the initial price path estimates superimposed. The methodology behind these price forecasts has changed from previous EIA price forecasts. The historical OPEC pricing strategy is reflected within the pricing procedure rather than the strict forecasts of market clearing prices from previous analyses. The high price assumption implies that by 1985 real oil prices rise 5.2 percent annually from the April 1980 level, 2.4 percent annually between 1985 and 1990, and 4.9 percent annually between 1990 and 1995. The average rise in the real price of oil for the 1980-95 period is 4.2 percent annually. In the midprice assumption, the average growth in real price is 2.0 percent annually from 1980 to 1995. The low price assumption is that oil prices will remain level in real terms throughout the forecast period, recognizing that

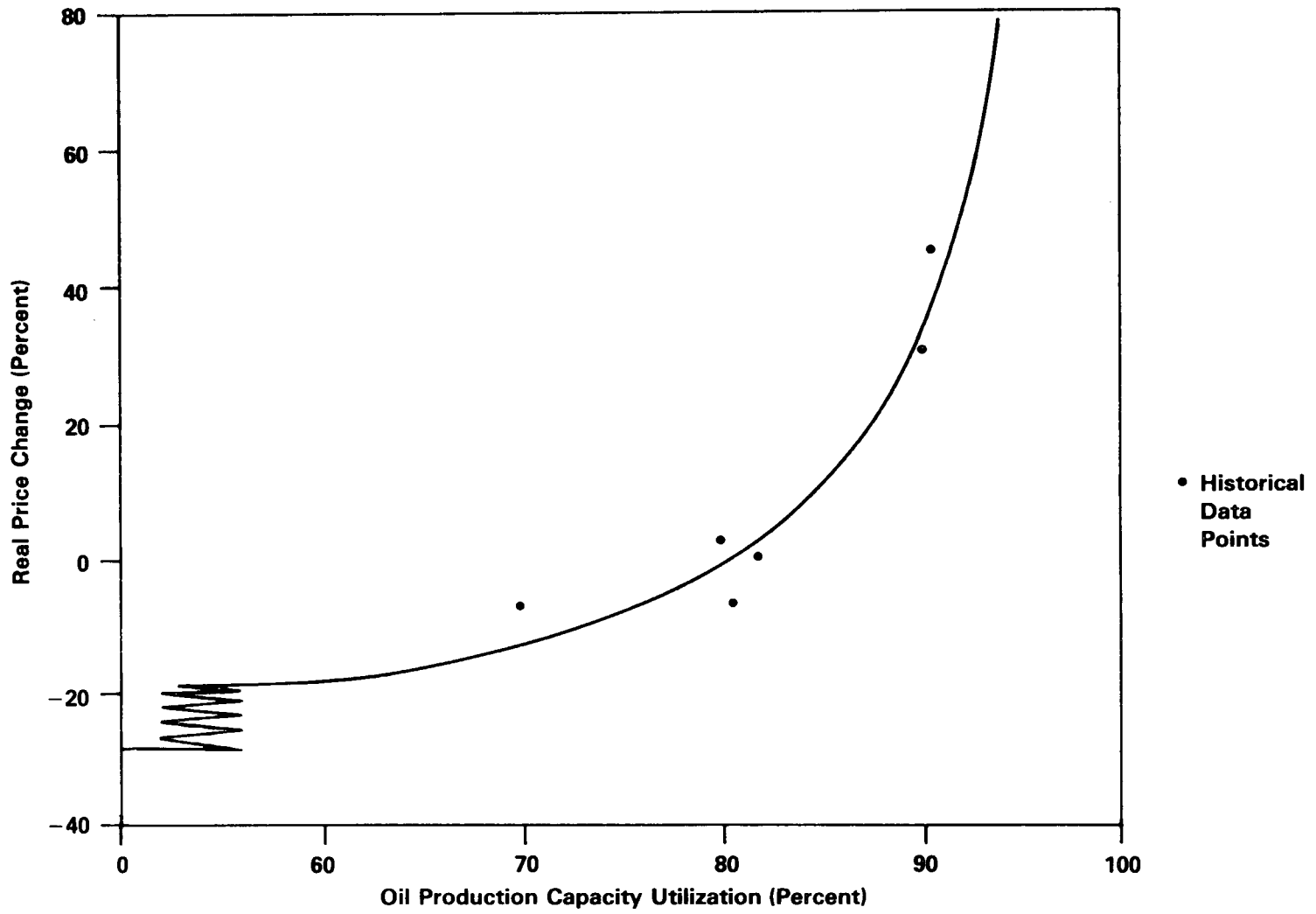

Figure 2.1 OPEC Pricing Behavior

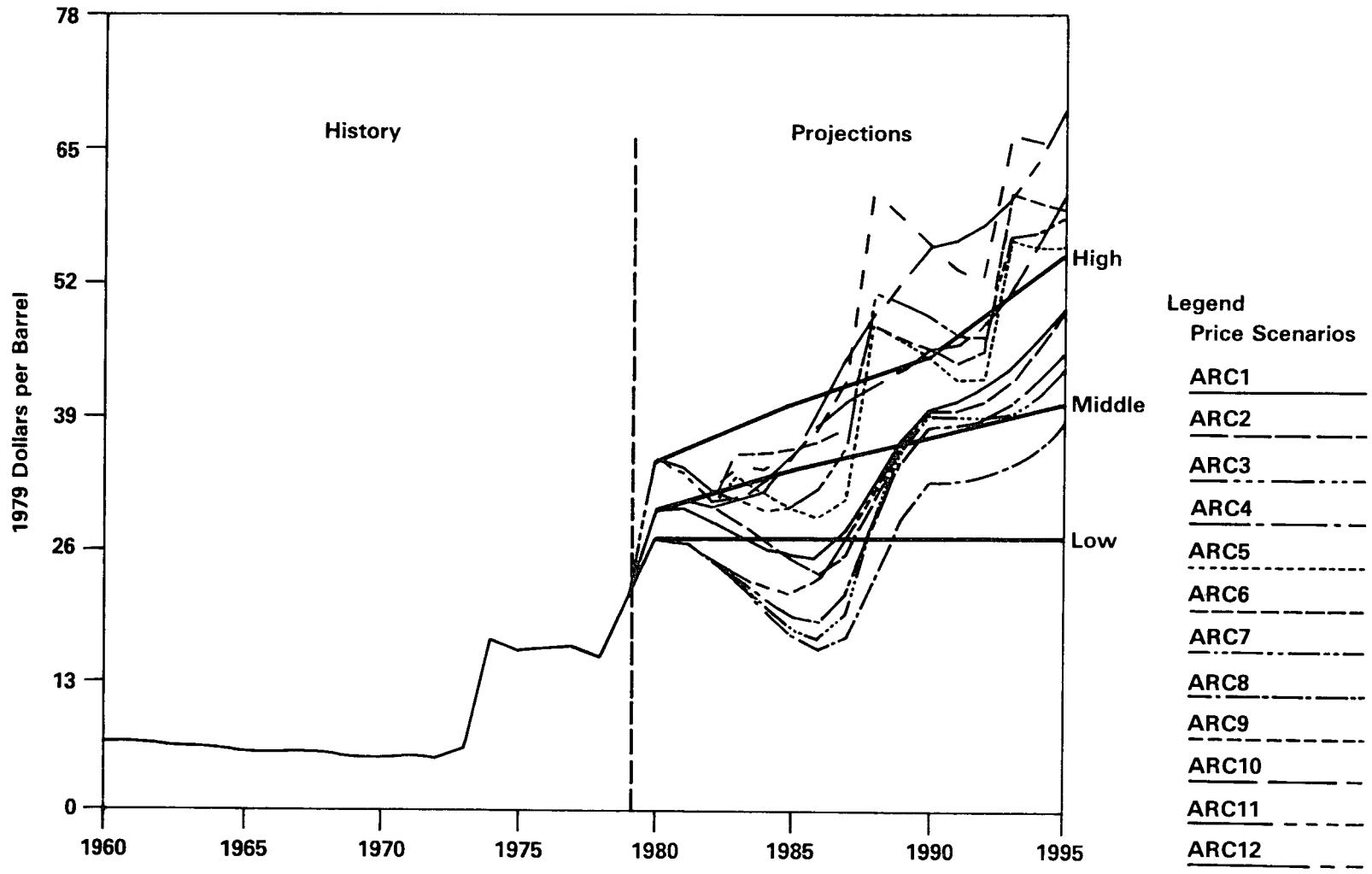

Figure 2.2 Alternative World Oil Prices, 1960–1995

the possibility of oil price increases only to compensate for inflation.

The oil price projections for the 12 scenarios, produced in the final step, indicate future trends in oil prices somewhat higher than the initial price path assumptions. This higher trend is mainly a result of the lower estimates of future OPEC production capacities than were initially assumed.

### Price Uncertainty Through Sensitivity Analysis

Because of the high uncertainty in forecasting world oil prices, it is useful to examine assumptions having a profound impact on the price projections. A sensitivity analysis was developed to isolate the effects of individual key assumptions on the price of world oil. The parameters addressed in the analysis include economic growth in foreign countries, oil production in non-OPEC countries, available OPEC production capacity, and a 1 million barrel per day increase in world oil consumption.

The analysis consists of a base case of midprice supply and demand assumptions and several scenarios that examine the effects of varying individual parameters on the world price of oil. All price sensitivities are analyzed under two hypotheses regarding OPEC pricing. The first hypothesis assumes that OPEC prices its oil consistent with the pricing behavior exhibited since the 1973 embargo. The second hypothesis assumes that OPEC oil is priced well above the market level that midprice case demands would normally dictate.

Specifically, the high price assumptions, presented in Table 2.2, were used for the second pricing hypothesis. The use of alternative pricing assumptions results in a range of price sensitivities for each parameter examined because of the different levels of slack OPEC production capacity that are available under the different market conditions.

Table 2.4 summarizes the results of the sensitivity analysis. Each sensitivity parameter is varied over a specified range. The effect of these variances on the price of world oil is shown for each forecast year. The lower end of each sensitivity range corresponds to the second market hypothesis: the high price OPEC behavior. With prices artificially high, the demand for OPEC oil is decreased and results in a high percentage of unused OPEC production capacity. Therefore, an increase in the demand for OPEC oil does not have such a dramatic effect on price because of the large slack OPEC capacity. The upper end of the sensitivity range corresponds to the average pricing behavior OPEC has exhibited since the 1973 embargo. An increase in the demand for OPEC oil results in a more dramatic price increase as OPEC production moves closer to capacity. As shown, the price forecasts presented in this chapter are quite sensitive to the scenario assumptions and the parameters considered.

If the world economic growth rate is increased 0.4 percentage points per year over the midprice assumption, the net effect of this increase results in roughly a \$2.90 to \$4 per barrel price increase over the 1995 midprice estimate.

The unwillingness of OPEC producers to expand their sustainable production capacities has a

**Table 2.4 World Oil Price Sensitivity Analysis, 1985, 1990, and 1995**  
(1979 Dollars per Barrel)

Sensitivity Parameter	Effects on Oil Prices <sup>a</sup>		
	1985	1990	1995
High Economic Growth <sup>b</sup> .....	0.42-1.38	1.30-3.20	2.89-4.03
Low Non-OPEC Production <sup>c</sup> .....	1.57-4.87	2.66-5.72	4.75-6.08
Low OPEC Production Capacity <sup>d</sup> .....	1.00-3.62	2.28-5.34	5.02-7.00
World Oil Consumption Increase of 1 Million Barrels per Day .....	0.49-1.46	0.53-2.13	0.85-3.02

<sup>a</sup>The lower end of the sensitivity range corresponds to the high price environment where a change in the demand for OPEC oil does not have as drastic an impact on price due to large slack OPEC capacity. The upper end of the sensitivity range corresponds to a pricing environment consistent with midrange demands, while a change in the demand for OPEC oil has a more drastic impact on price due to the proximity of OPEC production to OPEC capacity.

<sup>b</sup>Plus 0.4 percent per year over the midrange growth estimates.

<sup>c</sup>Midrange estimates: 1985—23.9 million barrels per day, 1990—25.1 million barrels per day, 1995—26.0 million barrels per day. Low estimates: 1985—21.0 million barrels per day, 1990—21.7 million barrels per day, 1995—22.4 million barrels per day.

<sup>d</sup>Midrange estimates: 1985—34.1 million barrels per day, 1990—34.6 million barrels per day, 1995—34.8 million barrels per day. Low estimates: 1985—32.0 million barrels per day, 1990—30.3 million barrels per day, 1995—29.7 million barrels per day.

pronounced effect on future oil prices. If OPEC continues its trend of recent years and reduces its capacity because of oil reserve conservation goals, oil prices could increase by as much as \$7 per barrel in 1995 over the midprice estimate.

The sensitivity case of an increase in world oil consumption by 1 million barrels per day addresses such issues as the effect of an equivalent increase in U.S. petroleum imports by 1 million barrels per day. This case also shows the effect of Communist nations becoming net petroleum importers of 1 million barrels per day by the forecast years.

Because the price of world oil has a high sensitivity to the various parameters, the price forecasts presented in this chapter should only be considered representative and not precise estimates of future prices. Indeed, if all the parameters were at the extreme points to yield the maximum price increase, the price differentials over the 1985, 1990, and 1995 midprice forecasts would be \$9.20, \$15.40, and \$19 per barrel, respectively. Likewise, if all parameters were adjusted to yield the maximum price decrease, the price differentials would be \$7.80, \$7.20, and \$11.70 per barrel below the respective 1985, 1990, and 1995 midprice estimates. This effect indicates a level of price uncertainty in 1985 of up to \$17 per barrel; in 1990, \$22.60 per barrel; and in 1995, \$30.70 per barrel. These figures indicate the range of some of the uncertainty surrounding the oil price projections, as quantified in this analysis; however, other factors not quantified could add to this uncertainty.

## WORLD OIL MARKETS

Oil dominates the international energy market. In the United States, for example, the 1978 net energy imports totaled 17.3 quadrillion Btu, with crude oil and refined petroleum product net imports at 13.1 and 3.9 quadrillion Btu (or 6.2 and 1.8 million barrels per day), respectively. The United States was a net exporter of coal at 1.0 quadrillion Btu in 1978.<sup>1</sup> In addition, oil dominates the traded energy for European member countries of the Organization for Economic Cooperation and Development (OECD). For those countries, petroleum and petroleum

<sup>1</sup> United States energy trade figures are from the Energy Information Administration, U.S. Department of Energy, *Annual Report to Congress, 1979 Vol. 2, and Monthly Energy Review*, February 1980.

products accounted for 86 percent of the value of energy imports and 74 percent of the energy exports in 1978.<sup>2</sup>

In 1978, the United States imported about 44 percent of its petroleum supplies (about 12 percent from the Persian Gulf countries) and is expected to maintain a somewhat lower level of dependency throughout the forecast period.<sup>3</sup> These forecasts of the world oil market supply and demand are consistent with the net import forecasts for the United States, as presented in other chapters of this report.

## Historical Oil Consumption

Table 2.5 and Figure 2.3 provide a historical overview of regional production plus net imports for the United States, Canada, Japan, Europe, OPEC, and the remaining developing countries. The data in Table 2.5 incorporate all stock level changes from year to year, and are therefore not measurements of end-use consumption but rather represent "apparent" oil consumption.

The effects of postembargo price hikes and subsequent reductions in economic activity on oil consumption become evident when comparing average annual rates of growth in oil consumption before and after 1973. Between 1950 and 1973, the average growth rate was 4.3 percent in the United States, 7.9 percent in Canada, and 25.0 percent in Japan; between 1973 and 1978, however, oil consumption growth rates in these three countries were reduced to 1.5, -0.2, and -0.4 percent, respectively. Similar reductions occurred in other areas of the world. The 1950-73 rate in Europe was 12.3 percent, compared with a 1973-78 rate of -1.7 percent. Comparable rates were 6.1 and 2.0 percent in the developing countries, 10.4 and 5.6 percent in the OPEC countries, and 7.1 and 0.6 percent in the free world as a whole.

The share of total free world oil consumed by the respective regions has also changed significantly over time. Most striking is the decline in the

<sup>2</sup> OECD Europe trade figures are from the Organization for Economic Cooperation and Development, *Statistics of Foreign Trade*, (Paris, France: 1978).

<sup>3</sup> The 44 percent dependency on imported petroleum in 1978 is calculated as the total oil imports, including the Strategic Petroleum Reserve, divided by the products supplied. See Energy Information Administration, U.S. Department of Energy, *Monthly Energy Review*, February 1980, pp. 34, 36.

**Table 2.5 Historical World Oil Apparent Consumption, 1950 to 1978<sup>a</sup>**  
(Thousand Barrels per Day)

Year	United States <sup>b</sup>	Canada	Japan	Europe	Developing Countries <sup>c</sup>	OPEC	Total Free World <sup>d</sup>
1950	6,451	324	31	1,048	1,992	196	10,042
1955	8,458	548	152	1,960	3,116	342	14,576
1960	9,577	837	644	4,535	2,796	666	19,055
1965	11,294	1,143	1,803	8,257	3,840	840	27,177
1970	14,457	1,472	4,183	13,580	5,856	1,162	40,710
1971	14,857	1,538	4,411	14,066	6,662	1,291	42,825
1972	15,703	1,689	4,805	14,713	6,469	1,430	44,809
1973	16,971	1,867	5,207	15,153	7,784	1,925	48,907
1974	16,354	1,892	5,499	14,294	9,292	1,985	49,316
1975	15,854	1,782	5,123	12,726	7,265	2,296	45,046
1976	16,825	1,762	5,370	14,034	8,505	2,398	48,894
1977	18,428	1,928	5,731	14,013	7,918	2,637	50,655
1978	18,276	1,850	5,115	13,924	8,588	2,522	50,275

<sup>a</sup>Defined as domestic production of crude oil and natural gas liquids plus net imports of crude oil and petroleum products. These oil supplies may go to end use consumption or to stocks. Stocks going to end-use consumption are not explicitly measured.

<sup>b</sup>Excludes Puerto Rico and Virgin Islands, but includes additions to the Strategic Petroleum Reserve.

<sup>c</sup>Also includes Puerto Rico, Virgin Islands, South Africa, Australia, and New Zealand. These figures were calculated to balance total production and consumption by the other regions.

<sup>d</sup>Includes production of crude oil and natural gas liquids and net oil exports from the Communist countries.

Source: Based on data and estimates from U.S. Department of Energy, International Affairs; U.S. Department of Energy, Energy Information Administration, *Monthly Energy Review* and *International Petroleum Annual*; and Central Intelligence Agency, *International Energy Statistical Review*. Amounts prior to 1973 were estimated by the Energy Information Administration.

world share of oil consumed by the United States, from 64.2 percent in 1950 to 36.4 percent in 1978. However, the Japanese share of total consumption went from 0.3 percent in 1950 to 10.2 percent in 1978 and the European share went from 10.4 percent to 27.7 percent over this same period. Both Japan and the major industrial countries in Europe experienced rapid economic growth after World War II and prior to the oil embargo.

### Iranian Disruption

The shortfall of imported oil in 1979 again demonstrated the importance of OPEC petroleum imports to the United States. Several factors contributed to the shortfall, but the overriding factor was the production cutback in Iran.<sup>4</sup> Attempts to increase stocks in the latter part of 1978 were hindered by the Iranian disruption, placing an additional burden on imports in early 1979. As Table 2.6 demonstrates, the non-Iranian OPEC members, primarily Saudi Arabia, increased production to offset the Iranian reduction. The increased production did not completely compensate for the loss, however, and the net loss in the first quarter of 1979 in world production from the expected level was estimated at 2 to 3 million barrels per day.

The tight world oil market and the uncertainty resulting from the Iranian disruption caused world oil prices to soar in 1979. At the beginning of 1979, the weighted average official lifting price of internationally traded oil, including surcharges, was \$13.77 per barrel. By January 1, 1980, the price was \$28.45, a 107-percent hike. New York spot market prices for motor gasoline at \$21.42 per barrel in January 1979 were as high as \$50.82 by December of that year.<sup>5</sup>

### Foreign Production Possibilities

In 1979, Saudi Arabia regained its position as the world's second largest producer of crude oil—excluding natural gas liquids—again replacing the United States. The Soviet Union has been the largest producer since 1974. The United States/Saudi Arabia change reaffirms the grow-

<sup>4</sup> The Office of Applied Analysis, Energy Information Administration, U.S. Department of Energy, *An Analysis of the World Oil Market, 1974-1979*, DOE/EIA-0184/9 (Washington, D.C.: U.S. Department of Energy, 1979).

<sup>5</sup> The world oil prices quoted are from U.S. Department of Energy, *Weekly Petroleum Status Report*, January 18 and April 25, 1980.

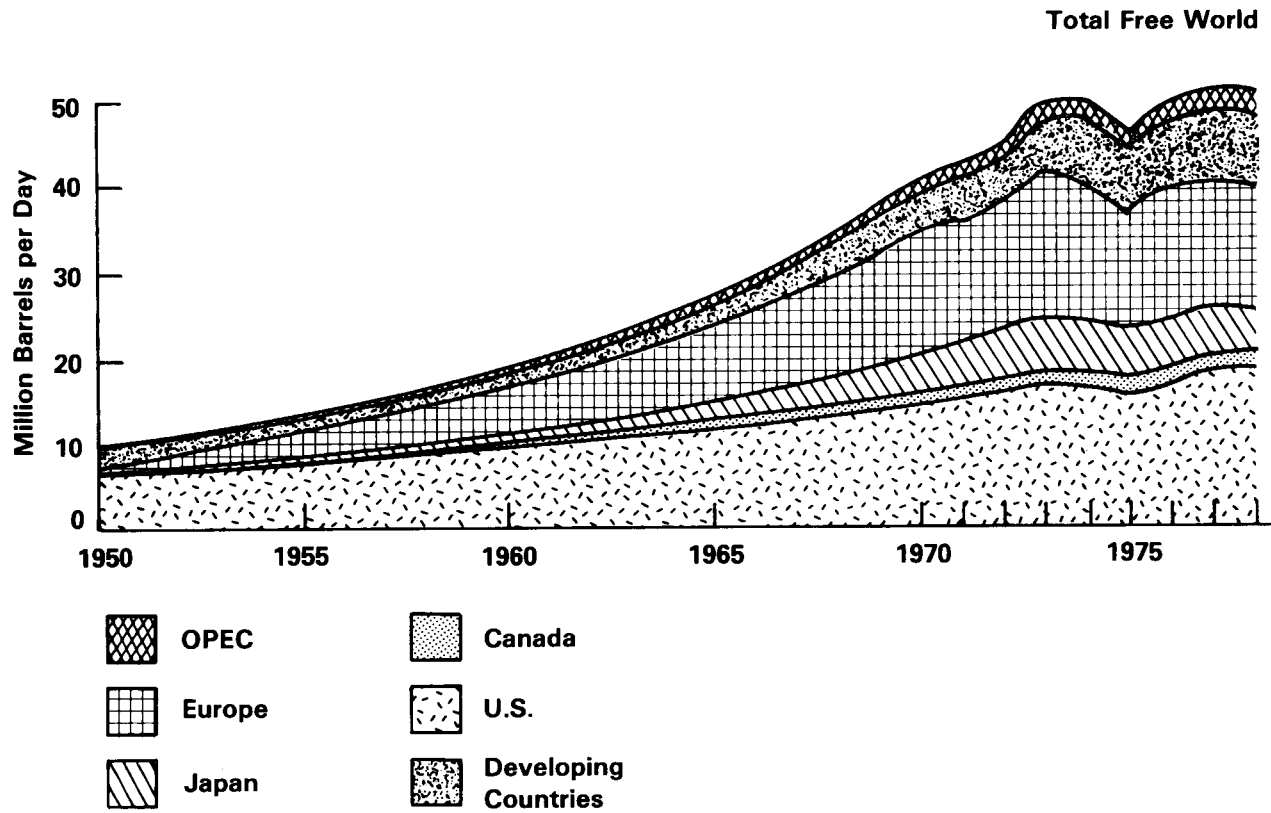

Note: Data for the years 1951-1954, 1956-1959, 1961-1964 and 1966-1969 are interpolated.  
 Source: Data and definition of apparent consumption from Table 2.5.

**Figure 2.3 World Oil Apparent Consumption, 1950-1978**

**Table 2.6 Free World Production of Crude Oil and Natural Gas Liquids Plus Net Centrally Planned Economies (CPE) Exports  
(Million Barrels per Day)**

Year	Non-OPEC Free World	OPEC Less Iran	Iran	OPEC <sup>a</sup>	Net CPE Exports	Total <sup>a</sup>
<b>1977</b>						
First Quarter .....	17.2	26.2	5.8	32.1	1.3	50.6
Second Quarter .....	17.4	26.3	5.5	31.8	1.3	50.5
Third Quarter .....	17.6	25.4	5.5	30.9	1.3	49.8
Fourth Quarter .....	18.3	26.1	6.1	32.2	1.3	51.8
Average <sup>b</sup> .....	17.6	26.1	5.7	31.8	1.3	50.6
<b>1978</b>						
First Quarter .....	18.5	23.3	5.5	28.8	1.0	48.3
Second Quarter .....	18.9	23.7	5.7	29.4	1.0	49.3
Third Quarter .....	19.0	24.9	5.9	30.8	1.0	50.8
October .....	19.2	26.7	5.5	32.3	1.0	52.4
November .....	19.4	29.0	3.5	32.6	1.0	53.0
December .....	19.7	28.6	2.4	31.0	1.0	51.7
Average <sup>b</sup> .....	18.8	25.2	5.3	30.5	1.0	50.3
<b>1979</b>						
January .....	19.8	28.7	0.4	29.1	1.0	49.9
February .....	19.9	28.8	0.8	29.6	1.0	50.5
March .....	19.8	28.5	2.2	30.7	1.0	51.5
April .....	19.9	27.1	3.8	30.9	0.8	51.6
May .....	19.9	27.3	4.1	31.4	0.8	52.1
June .....	20.0	27.3	4.0	31.3	0.8	52.1
Average (first half) <sup>b</sup> .....	19.9	27.9	2.6	30.5	0.9	51.3

<sup>a</sup>Numbers may not add to totals due to rounding.

<sup>b</sup>Averages for 1977 are from the CIA source listed below. Averages for 1978 are from Tables 2.8 and 2.9. Averages for 1979 are derived from the monthly data as shown in the table.

Source: Net exports from Centrally Planned Economies (CPE) obtained from U.S. Department of Energy, International Affairs. The 1977 and 1978 Free World estimates are from Central Intelligence Agency, *International Energy Statistical Review*. The 1979 Free World estimates are from U.S. Department of Energy, International Affairs, *International Energy Indicators*; and Central Intelligence Agency, *International Energy Statistical Review*.

ing importance of production possibilities external to the United States.

In the recent past, the CPE countries have been net exporters of oil. In 1979, net exports from these countries, primarily the Soviet Union, averaged about 0.8 million barrels per day. Soviet production, which appears to be leveling off, must also meet much of Eastern Europe's oil needs. In the projections, the CPE countries are shown ranging from net exporters of 1 million barrels per day to net importers of 1 million barrels per day.

Increased production in China will match its increased consumption, allowing for only small gains in its net exports. Like China, increased production in the developing countries will be partially offset by their increased consumption. Higher production is expected primarily from Mexico, Egypt, India, and Malaysia. These countries will also consume more oil, as will such developing countries as Brazil and South Korea. Oil production from the OECD countries will rise slowly over the next few years. The projected

increase in production is primarily because of North Sea operations.<sup>6</sup>

Production possibilities for OPEC are presented in Table 2.7. These are the production limits in the oil pricing analysis described earlier. The low capacity estimates are based on the assumption that OPEC will not or cannot maintain current capacity levels over the years. Iran, Kuwait, Saudi Arabia, and Abu Dhabi are assumed to continue administrative production ceilings. In the low case, OPEC crude oil and natural gas liquids production capacity falls about 3.9 million barrels per day, or 11.4 percent, between 1980 and 1990. The middle case has capacities about the same or slightly above current levels throughout the time horizon. The high case yields an additional 5 million barrels per day by 1995 in comparison to the middle case;

<sup>6</sup> The discussion on China, the developing countries, and OECD is based on a survey presented by the Central Intelligence Agency, "The World Oil Market in the Years Ahead," August 1979.



**Table 2.7 OPEC Production Capacity, 1980 to 1995**  
(Million Barrels per Day)

Country	Scenario Supply	Projections									
		1980	1985			1990			1995		
			High Low	Mid Mid	Low High	High Low	Mid Mid	Low High	High Low	Mid Mid	Low High
<b>Crude Oil</b>											
Saudi Arabia <sup>a</sup>		9.8	9.5	10.5	12.5	9.5	11.0	12.5	9.5	11.0	12.5
Iran		4.0	3.5	4.0	4.5	3.0	4.0	4.5	3.0	4.0	4.5
Iraq		3.7	3.5	3.8	4.5	3.5	4.0	5.0	3.5	4.5	5.0
Kuwait <sup>a</sup>		2.8	2.5	2.5	2.8	2.5	2.5	2.7	2.5	2.5	2.7
United Arab Emirates		2.4	2.5	2.5	2.8	2.5	2.5	2.8	2.5	2.5	2.8
Libya		2.2	1.8	2.0	2.3	1.5	2.0	2.3	1.2	1.7	2.3
Nigeria		2.2	2.0	2.1	2.5	1.8	2.0	2.3	1.8	2.0	2.3
Venezuela <sup>b</sup>		2.4	2.0	2.0	2.3	1.7	2.0	2.3	2.0	2.3	2.5
Indonesia		1.7	1.5	1.5	1.9	1.4	1.6	1.8	1.1	1.3	1.5
Algeria		0.9	0.8	0.8	1.0	0.6	0.7	0.9	0.5	0.6	0.7
Ecuador		0.2	0.2	0.2	0.2	0.2	0.2	0.2	0.1	0.2	0.2
Gabon		0.2	0.2	0.2	0.2	0.2	0.2	0.2	0.1	0.2	0.2
Qatar		0.6	0.5	0.5	0.5	0.4	0.4	0.5	0.2	0.3	0.4
Total Crude Oil <sup>c</sup>		33.4	30.5	32.6	38.0	28.8	33.1	38.0	28.0	33.1	37.6
Natural Gas Liquids		0.8	1.5	1.5	1.8	1.5	1.5	1.8	1.7	1.7	2.2
Total <sup>c</sup>		34.2	32.0	34.1	39.8	30.3	34.6	39.8	29.7	34.8	39.8

<sup>a</sup>Includes share of Neutral Zone production.

<sup>b</sup>Includes 0.3-0.5 million barrels per day of heavy oil in 1995.

<sup>c</sup>Production ceilings applied by Abu Dhabi, Kuwait, Iran, and Saudi Arabia, reduce available 1980 total crude oil production and total oil plus natural gas liquids to 31.2 and 32.0 million barrels per day, respectively.

Source: Natural Gas Liquids estimates and projected crude oil estimates from U.S. Department of Energy, International Affairs. The 1980 crude oil estimates are from U.S. Department of Energy, Office of International Affairs, *International Energy Indicators*. All other 1980 crude oil estimates are from Central Intelligence Agency, *International Energy Statistical Review*.

the high case also reflects an expansion rate approaching estimated physical production capacity limits except, again, for the countries imposing administrative constraints.

## Forecasts of Oil Production

Projections of world oil production are presented in Figure 2.4 and Table 2.8. Three ranges are considered: low, middle, and high. By 1990, production in the free world is estimated to be between 52.3 and 56.0 million barrels per day, an increase, at most, of 13.6 percent from the 1978 level of 49.3 million barrels per day. The share of total OPEC production falls from 62 percent in 1978 to 50-54 percent in 1990. In contrast, Mexico becomes a major producer by 1990, exceeded only by the United States and Saudi Arabia in the free world. Mexico's share of total production increases from 2.6 percent in 1978 to 6.7-8.9 percent in 1990.

The U.S. production forecasts are discussed in

more detail in Chapter 4. The forecasts of foreign, non-OPEC production are derived from a range of judgmental (constant price) production capacities.<sup>7</sup> The latter estimates are made consistent with projected oil price levels, using an assumed long-run supply elasticity of 0.1 in the price of oil for 1985 and 0.2 for 1990 and 1995.<sup>8</sup>

The OPEC production forecasts in Table 2.8 fall within the limits specified in Table 2.7. Reduced OPEC production through 1990 implies reduced oil supplies for the rest of the world. Total exports from the Persian Gulf countries, for example, are projected to fall from a 1978 level of 23.6 million

<sup>7</sup> Ranges of foreign supply potential (at constant oil prices) are provided by the Office of International Affairs, U.S. Department of Energy.

<sup>8</sup> A long-run price elasticity of 0.2 for all foreign non-OPEC countries implies that for each 1 percent increase in real oil prices, production will increase by a maximum of 0.2 percent over a period of 10 years.

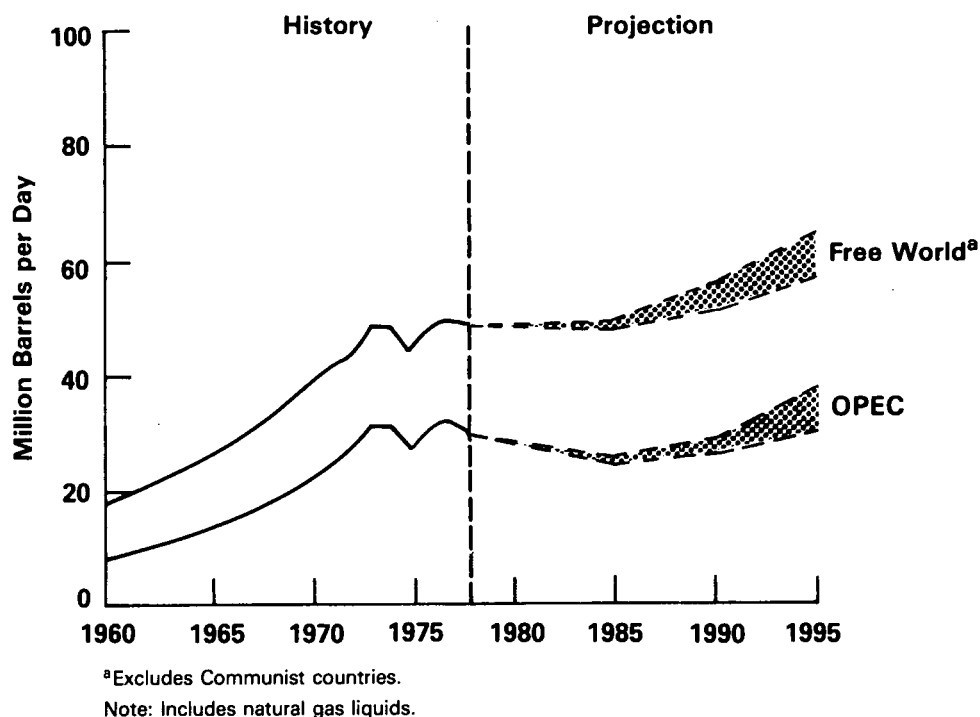

**Figure 2.4 World Oil Production: OPEC and Non-OPEC, 1960–1995**

**Table 2.8 Free World Oil Production by Country:<sup>a</sup> Midprice Scenario and High-Low Scenario Projection Range, 1978 to 1995 (Million Barrels per Day)**

Country or Region	Midprice Scenario				Range (From the High and Low Scenarios)		
	1978	1985	1990	1995	1985	1990	1995
United States .....	10.3	9.2	9.6	9.7	9.3–9.1	9.9–8.9	10.5–8.1
Canada .....	1.6	1.6	1.8	1.7	1.5–1.7	1.6–1.7	1.7–1.7
OECD Europe.....	1.8	3.6	3.5	3.6	3.1–3.9	3.3–3.9	3.2–3.9
OECD Pacific .....	0.5	0.5	0.5	0.4	0.4–0.5	0.4–0.5	0.3–0.5
<b>Total OECD<sup>b</sup>.....</b>	<b>14.2</b>	<b>14.9</b>	<b>15.5</b>	<b>15.5</b>	<b>14.3–15.2</b>	<b>15.3–15.0</b>	<b>15.8–14.2</b>
Saudi Arabia <sup>c</sup> .....	8.6	7.5	7.7	9.9	8.7–5.1	9.2–6.6	10.7–12.4
Iran .....	5.3	3.1	3.3	3.9	3.7–4.8	2.9–4.8	3.3–4.9
Other Persian Gulf.....	7.1	5.6	6.5	8.9	5.6–4.8	8.4–7.8	9.9–11.1
Libya/Algeria.....	3.3	2.6	2.7	2.3	2.6–3.3	2.1–3.2	1.7–3.0
Nigeria/Gabon .....	2.1	2.3	2.2	2.2	2.2–2.7	2.0–2.5	1.9–2.5
Venezuela/Ecuador.....	2.4	2.2	2.2	2.5	1.6–2.5	1.9–2.5	2.1–2.7
Indonesia .....	1.7	1.5	1.6	1.3	1.5–1.9	1.4–1.8	1.1–1.5
<b>Total OPEC<sup>b</sup>.....</b>	<b>30.5</b>	<b>24.8</b>	<b>26.3</b>	<b>31.0</b>	<b>25.9–25.1</b>	<b>28.0–29.2</b>	<b>30.7–38.1</b>
Mexico.....	1.3	3.5	4.0	5.0	3.0–4.0	3.5–5.0	4.0–5.5
Other Countries <sup>d</sup> .....	4.6	8.8	10.5	12.4	7.8–9.9	9.1–11.8	10.8–13.2
<b>Total Free World<sup>b</sup>.....</b>	<b>49.3</b>	<b>48.5</b>	<b>52.3</b>	<b>58.8</b>	<b>48.0–50.2</b>	<b>52.3–56.0</b>	<b>57.3–65.4</b>

<sup>a</sup>Includes crude oil and natural gas liquids. Therefore, the oil production capacities of Table 2.7 may be exceeded in this table.

<sup>b</sup>Numbers may not add to totals due to rounding.

<sup>c</sup>Includes 50 percent of Neutral Zone production.

<sup>d</sup>Includes Mexico.

Source: The 1978 amounts are from U.S. Department of Energy, Energy Information Administration, *Monthly Energy Review* and Central Intelligence Agency, *International Energy Statistical Review*.

barrels per day to 16–17 million barrels per day by 1990.<sup>9</sup>

Projections of free world oil production under the midprice scenario for the 1979 *Annual Report* are considerably lower than last year's midprice case (Series C). Midprice production levels for the United States have been reduced 1.6 million barrels per day for 1990 whereas OPEC production has been lowered 13.4 million barrels per day for the same time period. Production levels for the free world are down 16.1 million barrels per day for 1990 compared with the levels projected in the 1978 *Annual Report*. Overall, these differences reflect a less optimistic outlook for production potential around the world and an adherence to OPEC's stringently administered constraints. A later section, "Comparison with Previous EIA Forecasts," examines the difference between the current projections and those published last year in more detail.

## World Oil Balances

Table 2.9 provides an overview of world oil balances for the low, middle, and high projection series for 1985, 1990, and 1995. Note that total consumption (demand) in the free world is balanced with total production (supply) by the amount of net oil trade with the CPE countries.

The range of total consumption, shown in Table 2.9, mirrors the range of total production, listed in Table 2.8, less the net trade by the CPE countries. The United States, which accounts for over 36 percent of total consumption in 1978, is projected to remain the largest single user of oil in the free world, consuming from 29 to 31 percent of the total in 1990. The OECD consumption, not including the United States, represents 40 to 41 percent of the 1990 total. The developing countries (excluding OPEC) show the largest gain in share of total consumption, from 16 percent in 1978 to 20 percent in 1990. As mentioned previously, increased oil consumption in the non-OPEC developing countries will nearly offset increases in their production. For example, the 1990 midprice scenario estimates for production and consumption in these countries are 10.5 and 10.3 million barrels per day, respectively. (See Table 2.9.)

<sup>9</sup> The Persian Gulf countries consist of Iraq, Kuwait, Qatar, Saudi Arabia, United Arab Emirates, and Iran. The 1978 export estimate is from the Central Intelligence Agency, *International Energy Statistical Review*, February 27, 1980.

Projections of consumption in the midprice scenario for this year's report are lower, overall, than the comparable (Series C) projections for last year's report. The reduction in consumption from last year's 1990 midprice forecast for the total free world is 16.1 million barrels per day. The corresponding reductions are 3.9, 1.6, and 5.1 million barrels per day for the United States, Japan, and OECD Europe, respectively. Despite this year's lower projection, Japan is expected to sustain a relatively high growth in oil consumption chiefly because of the expected continued growth in the industry and raw materials sectors. The 1990 estimate of OPEC consumption is down 1.4 million barrels per day from last year's midprice estimate, again reflecting the higher prices for world oil. Yet, OPEC consumption is projected to be at least twice as great in 1990 as in 1978, thereby contributing to the projected reduction in net exports from 28 million barrels per day in 1978 to 21–24 million barrels per day by 1990.

## Oil Import Payments

Energy plays a significant role in overall international trade and, consequently, in the world economies. World trade in energy (coal, oil, gas, and electricity) accounted for approximately 20 percent of the world's total merchandise trade in 1976. In that year, OECD countries' energy trade constituted 22 percent of their merchandise imports and 5 percent of their exports. OPEC's energy trade accounted for 94 percent of their merchandise exports and 2 percent of their imports.<sup>10</sup>

For each of the EIA projection series, Table 2.10 presents the 1978 and the projected 1990 oil expenditures for each region of the world. In 1978, net oil import payments in the free world are estimated to be \$207 billion, which is 2.8 percent of the oil consuming countries' Gross Domestic Product (GDP). The OECD countries accounted for the bulk (91 percent) of the net oil payments. Japan's oil payments are 3.8 percent of its GDP; OECD Europe, 3 percent; and the United States, 2.6 percent.

<sup>10</sup> Wharton EFA, Inc. and SRI International, *Current Price World Trade Matrices by SITC Commodity Classes and by Regions, 1976*, November 1, 1978. The world trade figures include the Communist countries. The world exports of energy, excluding Communist countries, were \$176 billion and imports were \$183 billion.

**Table 2.9 World Oil Apparent Consumption and Production:<sup>a</sup> Projection Series High, Middle, and Low, 1985, 1990, and 1995**  
(Million Barrels per Day)

	1978	1985			1990			1995		
		High	Mid	Low	High	Mid	Low	High	Mid	Low
World Oil Price (dollars per barrel)		39.00	32.00	27.00	44.00	37.00	27.00	56.00	41.00	27.00
Supply		Low	Mid	High	Low	Mid	High	Low	Mid	High
Demand		High	Mid	Low	High	Mid	Low	High	Mid	Low
<b>Consumption</b>										
United States <sup>b</sup>	18.3	15.4	15.8	16.7	15.0	15.7	17.6	14.8	15.9	18.8
Canada	1.9	1.6	1.7	1.7	1.7	1.7	1.9	1.8	1.9	2.3
Japan	5.1	5.8	6.0	6.6	6.2	6.3	6.9	7.0	7.3	8.2
OECD Europe	13.9	11.6	12.2	12.9	12.1	12.5	13.6	12.4	13.5	15.3
France	2.3	1.9	2.0	2.1	2.0	2.1	2.2	2.1	2.3	2.6
Italy	2.1	1.6	1.7	1.7	1.7	1.7	1.8	1.7	1.8	2.0
United Kingdom/Ireland	2.0	1.7	1.8	1.9	1.8	1.9	2.0	1.9	2.0	2.3
West Germany	2.8	2.3	2.5	2.6	2.3	2.4	2.7	2.1	2.4	2.9
Australia/New Zealand	0.7	0.6	0.7	0.8	0.7	0.8	0.9	0.7	0.8	1.0
Total OECD	39.9	35.1	36.4	38.7	35.7	37.0	40.8	36.7	39.4	45.6
OPEC	2.5	3.9	3.7	3.7	5.4	5.0	5.0	7.3	6.7	6.6
Oil Exporting Developing Countries <sup>c</sup>	7.9	2.4	2.5	2.6	3.1	3.1	3.4	3.8	3.9	4.4
Oil Importing Developing Countries <sup>c</sup>		5.7	5.9	6.2	7.2	7.2	7.8	8.5	8.8	9.9
Total Consumption <sup>d</sup>	50.3	47.0	48.5	51.2	51.3	52.3	57.0	56.3	58.8	66.4
<b>Production</b>										
United States	10.3	9.3	9.2	9.1	9.9	9.6	8.9	10.5	9.7	8.1
Canada	1.6	1.5	1.6	1.7	1.6	1.8	1.7	1.7	1.7	1.7
OECD Europe	1.8	3.1	3.6	3.9	3.3	3.5	3.9	3.2	3.6	3.9
United Kingdom	1.1	2.0	2.3	2.5	2.1	2.3	2.5	2.0	2.3	2.5
Norway	0.4	0.8	1.0	1.0	0.9	1.0	1.1	0.9	1.0	1.0
Australia/New Zealand	0.5	0.4	0.5	0.5	0.4	0.5	0.5	0.3	0.4	0.5
Total OECD	14.2	14.3	14.9	15.2	15.3	15.5	15.0	15.8	15.5	14.2
OPEC	30.5	25.9	24.8	25.1	28.0	26.3	29.2	30.7	31.0	38.1
Oil Exporting Developing Countries <sup>c</sup>	4.6	5.7	6.5	7.2	6.7	7.7	8.8	7.8	9.0	9.6
Oil Importing Developing Countries <sup>c</sup>		2.1	2.3	2.7	2.4	2.8	3.0	3.0	3.4	3.6
Total Production <sup>d</sup>	49.3	48.0	48.5	50.2	52.3	52.3	56.0	57.3	58.8	65.4
Net Exports from Communist Countries (Imports)...	1.0	-1.0	0	1.0	-1.0	0	1.0	-1.0	0	1.0

<sup>a</sup>Includes crude oil and natural gas liquids; apparent consumption as defined in Table 2.5.

<sup>b</sup>Includes Puerto Rico, Virgin Islands, and purchases for the Strategic Petroleum Reserve.

<sup>c</sup>Excludes Communist countries.

<sup>d</sup>Numbers may not add to totals due to rounding.

Source: The 1978 amounts are from U.S. Department of Energy, Energy Information Administration, *Monthly Energy Review* and *International Petroleum Annual, 1978*; and Central Intelligence Agency, *International Energy Statistical Review*. Net CPE exports are from U.S. Department of Energy, International Affairs.

These percentages of GDP for net oil import payments give one measure of the burden on each country's economy. The higher the percentage of payments to output, the greater the impact of any change in the international oil market. The percentages represent the relative amount of output the oil consuming countries will have to transfer directly or indirectly to the oil exporting countries to pay for their imported oil.

The patterns of oil payments for the different scenarios reflect changes in the real prices of world oil, the quantities of imported oil, and the rate of economic growth. The net oil import payments for the non-OPEC free world for the midprice scenario are \$277 billion (1979 dollars) by 1990, 2.6 percent of the GDP, as compared with 2.8 percent in 1978. The projected range of OECD import payments relative to GDP is 2.7 to 3.4 percent for 1990.

## WORLD ENERGY MARKET

The factors underlying the analysis of the world energy market indicate a lower energy demand growth between 1977 and 1995, relative to 1960-77. These factors include higher energy prices, lower economic growth, lower population growth, and various conservation programs. The relative effects of these factors differ substantially throughout the world community and depend, in general, upon a country's endowment of energy resources, the availability of alternative energy supplies, "stage of capital development," climate, and price policies (such as price supports and controls as well as taxation). Additional considerations concern the sectoral composition of final

energy demand and corresponding efficiency of energy consuming capital stocks.

Although the analysis proceeds on a country-by-country basis, the forecasting procedure separates the world community into developed, developing, and oil exporting countries. The developed countries, namely, the OECD countries, are analyzed on a sectoral basis—transportation, industry, residential and commercial, and conversion. The analysis of the rest of the free world considers total fuel demand. Except for the Communist countries, which are analyzed on a net energy import basis, all regions are sensitive to the factors mentioned earlier. The present section reports only the results of the midprice projection series; however, the general conclusions also apply to the alternative high and low projection series.

**Table 2.10 Projected World Oil Import Payments: 1990**  
(Billions of 1979 Dollars)

Region or Country	World Oil Price (1979 dollars per barrel) Supply Demand	1978	1990		
			High 44.00 Low High	Mid 37.00 Mid Mid	Low 27.00 High Low
<b>United States</b>					
Import Payments.....		59.4	75.2	75.2	80.6
Percent of GDP <sup>a</sup> .....		2.6	2.4	2.4	2.5
<b>Canada</b>					
Import Payments.....		2.2	-0.2	-2.4	1.3
Percent of GDP.....		1.0	-0.1	-0.7	0.4
<b>Japan</b>					
Import Payments.....		37.0	100.0	84.1	66.9
Percent of GDP.....		3.8	6.5	5.6	4.5
<b>OECD Europe</b>					
Import Payments.....		88.1	138.0	119.0	93.1
Percent of GDP.....		3.0	3.4	3.1	2.4
<b>Australia/New Zealand</b>					
Import Payments.....		2.7	3.6	2.9	2.8
Percent of GDP.....		2.0	1.7	1.4	1.4
<b>OECD Total</b>					
Import Payments.....		189.0	317.0	279.0	245.0
Percent of GDP.....		2.9	3.4	3.1	2.7
<b>Other Non-OPEC</b>					
Import Payments.....		17.8	18.5	-2.2	-5.7
Percent of GDP.....		2.2	1.2	-0.2	-0.4
<b>World<sup>c</sup></b>					
Import Payments.....		207.0	335.0	277.0	239.0
Percent of GDP.....		2.8	3.1	2.6	2.3

<sup>a</sup>Gross Domestic Product.

<sup>b</sup>Estimated.

<sup>c</sup>Excludes OPEC and Communist countries.

## World Energy Market Overview

The primary implications of the analysis are, (1) that energy demand in the free world will grow at a lesser rate than during the historical period, (2) that oil's share will decline but still maintain a relatively large share and, (3) that natural gas, nuclear power, and, to lesser extent, coal will absorb the decline in oil's share. Although these conclusions can be drawn from an aggregate view of the world, significant intraregional exceptions are present and are discussed following the world outlook summary.

### Lowered World Energy Growth Outlook

Between 1960 and 1973, world energy consumption increased 5.4 percent and oil consumption expanded by 7.6 percent yearly. Following the oil embargo of 1973 and the ensuing world economic recession, world energy growth and world oil growth between 1973 and 1977 fell to 1.1 percent and 0.6 percent, respectively. The forecast of annual, average growth rates for world energy consumption and oil consumption between 1977 and 1990 are 2.1 percent and 0.4 percent, respectively. Free world energy consumption is expected to rise from 188 quadrillion Btu in 1977 to 246 quadrillion Btu in 1990, and oil consumption increases from 104 quadrillion Btu in 1977 to 109 quadrillion Btu in 1990.

### Energy Substitution and Decline in Free World Oil's Share

Between 1960 and 1977, oil's share of world energy consumption increased dramatically and almost singly offset coal's decreased share. The downturn in coal's share was mainly a result of its inferior quality as a fuel. The share of gas and "other" (hydro, geothermal, and nuclear) increase slightly. Oil, coal, gas, and "other" shares were 43, 35, 15, and 7 percent in 1960 and 55, 18, 17, and 10 percent in 1977, respectively. Between 1977 and 1990, oil's share is expected to decline, coal's to increase, gas' to remain virtually the same, and "other" to increase significantly. The downturn in oil's share is mainly a result of the increase in the relative cost of oil. The increase in the share of "other" is mainly a result of the increase in the use of nuclear power by the electric utilities. The

average free world shares of oil, coal, gas, and "other" are projected to be 45, 22, 18, 15 percent in 1990, respectively.

### Impact of Higher Energy Prices and Conservation

On the average, free world energy consumption per unit of real GDP in 1977, a summary measure of energy as a factor of production, was 8 percent below the rate in 1960. However, by 1990, world energy consumption per unit real GDP is projected to decline by 16 percent from its 1977 rate.

### Regional Differences as a Result of Economic and Population Outlooks

Between 1960 and 1973, annual energy growth averaged 5.2 and 6.9 percent for OECD and non-OECD countries, respectively. Between 1977 and 1990, the midprice series forecasts an annual energy growth rate of 1.2 percent for the OECD, 5.5 percent for non-OECD countries, and 7.4 percent for OPEC countries.

Because higher energy prices reduce energy demand by roughly the same degree in all countries, higher energy prices do not account for the forecasted differences in regional growth. An exception exists in the oil exporting countries, which are largely independent of higher energy prices, especially higher oil prices. Regional differences in energy growth forecasts are a result of the differences in economic and population growth forecasts, as opposed to higher energy prices.

Initially, economic growth forecasts show significant regional differences. (See Table 2.11.) Whereas the economic forecasts for the OECD countries are significantly reduced below the longer historical period, the forecasts for the non-OECD countries are at least as great as historical growth rates. Moreover, the oil exporting countries' rates are larger than historical rates. In particular, the GDP growth rates for the OECD countries averaged 4.9 percent annually between 1960 and 1972; however, for the midprice series, the average for 1977-95 is 2.9 percent. The GDP growth rate for the non-OECD countries was 5 percent per year between 1975 and 1977; the average growth rates between 1977 and 1995 for the OPEC countries and remaining countries are 5.9 and 5.1 percent, respectively.

The second major reason for regional differences in the forecasts is the result of differences in population forecasts. In particular, population growth between 1977 and 1995 averages 0.7 percent yearly for the OECD countries as compared to 2.6 percent for the non-OECD countries.

Actual energy consumption since the 1973-74 embargo supports the forecasted difference in regional growth and is consistent with the thesis of "stage of capital development" (defined broadly to include such standard of living indexes as household living space, automobiles per capita, electro-mechanical devices, and appliance saturations). Between 1973 and 1977, energy consumption rose at a rate of 0.5 percent annually and oil consumption declined by 0.2 percent annually for the OECD countries; this is compared to an annual energy growth rate of 4.7 percent and oil growth rate of 4.8 percent for the non-OECD countries.

### Shift in Regional Energy Shares

For the reasons outlined above, the forecast calls for a significant shift in the distribution of world energy consumption shares from the OECD countries to the developing non-OECD countries. In 1977, the shares of free world energy consumption were 84 percent in the OECD and 16 percent in the non-OECD countries. By 1990, the shares are forecasted to be 76 and 24 percent for the OECD and non-OECD countries, respectively.

Table 2.11 presents regional figures for total energy consumption in quadrillion Btu for 1960, 1973, and 1977. Also contained are corresponding fuel shares for each of the years. Tables 2.12A and 2.12B present the energy fuel share forecasts for 1985, 1990, and 1995. Table 2.13 contains growth rates for regional pre- and postembargo energy and oil consumption as well as growth rates for the midprice projection series for the 1977-90 period. Also presented in Table 2.13 are regional energy-GDP ratios in units of 1,000 Btu per constant 1975 U.S. dollars. These are presented for the historical years 1960, 1973, and 1977 and for the forecast years 1985, 1990, and 1995.

### OECD Energy Market

The OECD region consumed 88 percent of total free world energy in 1960, 84 percent in 1977, and

it is expected to consume 76 percent in 1990. The main conclusion in the analysis for this group of countries is (1) that energy growth between 1977 and 1990 will be very low, averaging only 1.2 percent yearly for the period and, (2) that oil consumption is expected to decline by 0.8 percent yearly over the same period. The main exception to these figures is Japan's annual growth, which is 3.3 percent for total energy and 0.9 percent for oil.

These results contrast sharply with the preembargo 1960-73 period, yet they are consistent with the postembargo 1973-77 period. High energy growth over the preembargo period, however, was a result of the relatively high economic growth and declining real energy prices. In such an environment, capital stock accumulation was large because of high economic growth but inefficient because of "cheap" energy. The postembargo period showed little stock accumulation because of world economic recessions, but "expensive" energy resulted in decreased utilization. The forecast period calls for reduced economic and population growth as well as "expensive" energy and is expected to be a period characterized by lower utilization and more efficient, energy-intensive capital stocks. Significant intraregional differences exist, and the forecasts for the OECD countries are based upon a sectoral analysis. The sectors are transportation, residential and commercial, industrial, and conversion.

### Conversion Sector

In 1977, net energy consumed by the conversion sector (primarily electric utilities) averaged 25 percent of total consumption for the OECD. In 1990, the net energy share consumed by the conversion sector increases slightly to an average 27 percent, of which electricity generation is expected to consume an average 25 percent on a net basis. One of the primary reasons for the reduction in the growth of energy demand forecasted for the OECD is the expected decrease in electricity demand growth relative to historical rates by the final user sectors. Between 1960 and 1977, total electricity distributed, including transmission losses, rose 6.3 percent annually for the OECD region. This contrasts sharply with the 2.6 percent annual rate expected over the 1977-90 period. Yet, electricity's growth forecasted for the 1977-90 period is more than double the growth

**Table 2.11 World Energy Consumption and Fuel Shares: History, 1960 to 1977**  
(Quadrillion Btu)

Region or Country	1960					1973					1977				
	Total Energy Consumed	Fuel Shares (percent)				Total Energy Consumed	Fuel Shares (percent)				Total Energy Consumed	Fuel Shares (percent)			
		Coal	Oil	Gas	Other		Coal	Oil	Gas	Other		Coal	Oil	Gas	Other
United States <sup>a</sup> .....	44.2	23	45	28	4	75.1	18	47	30	5	77.0	18	49	26	7
Canada.....	3.9	14	49	10	27	8.1	8	46	20	26	8.6	8	45	18	29
Japan.....	3.9	48	36	1	15	15.3	14	79	2	5	15.4	14	76	3	7
Western Europe <sup>b</sup> .....	26.9	55	35	2	8	54.0	19	63	10	8	54.0	19	58	13	10
Finland/Norway/Sweden..	1.8	13	49	0	38	3.9	5	58	0	37	4.2	5	56	1	38
United Kingdom/Ireland...	8.0	70	29	0	1	10.4	35	51	11	3	9.8	35	44	16	5
Benelux/Denmark <sup>c</sup> .....	2.7	53	47	0	0	7.3	11	67	22	0	6.8	11	60	27	2
West Germany.....	6.2	73	25	0	2	11.5	30	58	10	2	11.5	27	54	15	4
France.....	3.7	51	35	3	11	8.2	15	70	7	8	8.0	16	63	9	12
Austria/Switzerland.....	0.9	24	34	6	36	2.0	8	58	7	27	2.1	5	51	10	34
Spain/Portugal.....	1.0	41	41	0	18	3.0	14	70	2	14	3.5	14	68	2	16
Italy.....	2.2	14	54	11	21	6.2	5	78	10	7	6.4	6	70	15	9
Greece/Turkey.....	0.4	41	55	0	4	1.4	21	76	0	3	1.7	23	71	0	6
Australia/New Zealand.....	1.4	54	43	0	3	2.9	35	50	6	9	3.4	34	48	9	9
Total OECD <sup>d</sup> .....	80.4	35	42	16	7	155.4	18	56	19	7	158.4	18	54	19	9
Total Non-OECD <sup>e</sup> .....	10.5	31	57	6	6	25.0	21	60	11	8	30.0	19	60	11	10
OPEC.....	1.7	3	75	21	1	5.0	1	66	30	3	6.3	0	70	26	4
Other.....	8.8	37	53	4	6	20.0	25	59	7	9	23.8	24	58	7	11
Total Free World <sup>f</sup> .....	90.9	35	43	15	7	180.3	18	56	18	8	188.4	18	55	17	10

<sup>a</sup>Includes Puerto Rico, Virgin Islands, and purchases for the Strategic Petroleum Reserve.

<sup>b</sup>Numbers may not add to totals due to independent rounding.

<sup>c</sup>Benelux countries are Belgium, the Netherlands, and Luxembourg.

Source: Based on data from U.S. Department of Energy, Energy Information Administration, *Annual Report to Congress, 1979*, Vol. 2, and *International Petroleum Annual*, various years; Organization for Economic Cooperation and Development, *Basic Energy Statistics*, data tape, and *Energy Statistics, 1975/1977*; and United Nations, *World Energy Supplies*, data tape.

expected in total energy. In addition to higher oil prices, which influence electricity prices, lower economic growth, and lower population growth, the main factors contributing to electricity growth in developed OECD countries are increased conservation and appliance saturation.

### Transportation Sector

In 1977, the OECD transportation sector, including marine fuel, comprised 28 percent of total final demand; between 1960 and 1977 this demand increased at an annual rate of 4.3 percent. The expected growth between 1977 and 1990 for the total OECD transportation sector is 0.2 percent yearly, which is well below the rate for total energy consumption. The primary reason for the downturn expected in this sector is the effect of higher oil prices on this highly oil-dependent sector. The contribution to lower total energy growth for this sector's low growth forecast affects the United States more than any other OECD country, chiefly because of the large transportation share of total U.S. energy consumption.

### Residential and Commercial Sector

In 1977, the OECD residential and commercial sector, including agriculture and government consumption, represented 31 percent of total OECD final energy demand; between 1960 and 1977, however, that demand increased at an annual average rate of 2.5 percent. The expected growth for this aggregate sector between 1977 and 1990 is 0.6 percent per year. The primary reason for the expected outlook of low growth, in addition to lower population and economic growth, is higher energy prices. The fuel contributing to growth in this sector is electricity, which, as explained earlier, is below historical growth.

### Industrial Sector

In 1977, the OECD industrial sector, which includes the energy sector's own consumption and raw materials, represented 41 percent of total final demand; between 1960 and 1977, it increased at an annual rate of 3.9 percent. Between 1977 and 1990, the total OECD industrial sector is expected to rise



**Table 2.12A World Energy Consumption and Fuel Shares: History and Midprice Projections, 1985**  
(Quadrillion Btu)

Region or Country	1977					1985				
	Total Energy Consumed	Fuel Shares (percent)				Total Energy Consumed	Fuel Shares (percent)			
		Coal	Oil	Gas	Other		Coal	Oil	Gas	Other
United States <sup>a</sup> .....	77.0	18	49	26	7	82.6	27	39	23	11
Canada .....	8.6	8	45	18	29	10.0	6	38	20	36
Japan .....	15.4	14	76	3	7	19.7	12	64	13	11
Western Europe <sup>b</sup> .....	54.0	19	58	13	10	53.3	20	48	15	17
Finland/Norway/Sweden .....	4.2	5	56	1	38	4.7	4	44	1	51
United Kingdom/Ireland .....	9.8	35	44	16	5	9.1	35	42	17	6
Benelux/Denmark <sup>c</sup> .....	6.8	11	60	27	2	6.5	16	48	31	5
West Germany .....	11.5	27	54	14	5	12.0	30	43	19	8
France .....	8.0	16	63	9	12	8.2	13	53	10	24
Austria/Switzerland .....	2.1	5	51	10	34	2.0	8	43	12	37
Spain/Portugal .....	3.5	14	68	2	16	3.3	10	58	4	28
Italy .....	6.4	6	70	15	9	5.8	10	61	18	11
Greece/Turkey.....	1.7	23	71	0	6	1.6	27	58	0	15
Australia/New Zealand .....	3.4	34	48	9	9	3.7	34	41	15	10
Total OECD <sup>b</sup> .....	158.4	18	54	19	9	169.2	22	45	19	14
Total Non-OECD <sup>b</sup> .....	30.0	19	60	11	10	46.5	21	55	13	11
OPEC.....	6.3	0	70	26	4	11.7	1	67	31	1
Other .....	23.8	24	58	7	11	34.8	28	51	7	14
Total Free World <sup>b</sup> .....	188.4	18	55	17	10	215.7	22	47	18	13

<sup>a</sup>Includes Puerto Rico, Virgin Islands, and purchases for the Strategic Petroleum Reserve.

<sup>b</sup>Numbers may not add to totals due to independent rounding.

<sup>c</sup>Benelux countries are Belgium, the Netherlands, and Luxembourg.

Source: Data for 1977 are based on data from U.S. Department of Energy, Energy Information Administration, *Annual Report to Congress, 1979*, Vol. 2, and *International Petroleum Annual, 1977*; Organization for Economic Cooperation and Development, *Energy Statistics, 1975/1977*; and United Nations, *World Energy Supplies*, data tape.

1.9 percent yearly, which is greater than the growth for total consumption of OECD energy. Of the various final demand sectors, the industrial sector is the most flexible with respect to fuel substitution, thus mitigating the impact of the rising oil prices.

### Regional Energy Balances

Regional energy balances are presented in Table 2.14 for 1977, 1985, 1990, and 1995. Included are forecasts of both consumption and production for the midprice scenario and the historical data for 1977. At the bottom of each table, net energy trade with the CPE countries and stock changes, which include any statistical discrepancies, are presented to balance total free world supply and demand.

Regionally, energy consumption growth in the OECD countries is expected to drop sharply from 4.1 percent annually for the 1960-77 period to

between 1.2 and 1.4 percent annually over the 1977-90 period. Because production increases faster than consumption, the OECD energy imports, while still at a substantial level, are declining over this time frame. OECD's consumption is expected to rise from 158 quadrillion Btu in 1977 to 186 quadrillion Btu in 1990, whereas its production is projected to rise from 98.4 quadrillion Btu in 1977 to 133 quadrillion Btu in 1990. Energy growth rates in the developing countries, including OPEC, are expected to fall very little. Although the developing countries are starting from a relatively low base, their share of world energy consumption is expected to rise from 16 percent in 1977 to 24 percent by 1990. This increase in the developing countries' consumption is expected to offset, to a large extent, expected increases in their production over the forecast period. The OPEC countries are projected to consume 24 percent of their production by 1990, compared to 9.3 percent in 1977. The corresponding percentages for the non-

OPEC developing countries are 94 percent in 1990, compared to 126 percent in 1977.

## OECD Nuclear Power Developments

Because of the growing importance of electricity consumption in almost all regions, the delayed development of alternatives to oil-fired utility plants is a major source of uncertainty in the world energy market. In the United States, coal is expected to play an increasing role in future electric power generation, especially as a replacement for oil. For many of the other OECD countries, the moderate growth in future electricity and energy demand as replacement for oil is expected to be met mostly by nuclear generation and to a lesser extent by natural gas and coal. The potential levels of nuclear generating capacity for OECD and non-OECD countries are illustrated in Table 2.15. The other energy projections are made using the nuclear projections as input assumptions.

Decreased demand projections, rising investment costs, waste management issues, and renewed public anxiety over reactor safety and

siting have prompted many governments to position the nuclear option in a lower priority. As a result, EIA forecasts of nuclear power are slightly lower than those made last year. In the absence of specific waste management policies, the Benelux and some of the Scandinavian countries are now reticent to commit additional reactor projects. The Austrian public referendum in November 1978, which denied a completed reactor an operating license, and the recent Swedish vote for nuclear power added great uncertainty to the ongoing European debate. West Germany and Japan share similar political uncertainties with a particular lack of consensus between state and federal jurisdictions. Of the major OECD countries, only France possesses a clear national government policy that is reinforced by an extensive commitment of industrial resources and is the only major program in a non-Communist country continuing on schedule.

This national resolve is illustrated in the following comparison: EIA forecasts that for OECD members other than the United States taken collectively, nuclear energy may provide 21 to 23 percent of total electricity generated by 1990

**Table 2.12B World Energy Consumption and Fuel Shares: Midprice Projections, 1990 and 1995**  
(Quadrillion Btu)

Region or Country	1977					1985				
	Total Energy Consumed	Fuel Shares (percent)				Total Energy Consumed	Fuel Shares (percent)			
		Coal	Oil	Gas	Other		Coal	Oil	Gas	Other
United States <sup>a</sup> .....	89.8	29	36	22	13	97.4	34	33	19	14
Canada .....	11.3	5	35	20	40	12.9	4	34	19	43
Japan .....	23.6	13	55	19	13	29.1	15	52	19	14
Western Europe <sup>b</sup> .....	57.3	19	46	16	19	63.3	18	45	17	20
Finland/Norway/Sweden .....	5.1	5	42	1	52	5.3	4	41	2	53
United Kingdom/Ireland .....	9.4	31	42	18	9	10.2	29	43	19	9
Benelux/Denmark <sup>c</sup> .....	7.3	18	48	29	5	8.4	20	48	28	4
West Germany .....	12.7	31	39	20	10	13.5	31	37	20	12
France .....	8.8	12	49	11	28	10.3	10	48	12	30
Austria/Switzerland .....	2.2	8	39	16	37	2.4	8	38	18	36
Spain/Portugal .....	3.7	9	53	6	32	4.2	8	52	8	32
Italy .....	6.1	10	58	19	13	6.7	11	56	20	13
Greece/Turkey .....	1.9	20	56	0	24	2.2	17	55	0	28
Australia/New Zealand .....	4.1	33	39	19	9	4.6	32	38	20	10
Total OECD <sup>b</sup> .....	186.0	23	41	19	17	207.3	25	40	18	17
Total Non-OECD <sup>b</sup> .....	60.1	21	54	13	12	75.9	22	54	14	10
OPEC .....	15.8	0	68	31	1	20.9	0	68	31	1
Other .....	44.3	29	49	7	15	55.0	30	49	7	14
Total Free World <sup>b</sup> .....	246.1	22	45	18	15	283.2	24	43	17	16

<sup>a</sup>Includes Puerto Rico and Virgin Islands.

<sup>b</sup>Numbers may not add to totals due to independent rounding.

<sup>c</sup>Benelux countries are Belgium, the Netherlands, and Luxembourg.

whereas in France it could represent between 58 and 68 percent of total production. Although these forecasts are reduced from previous estimates, the growth of nuclear power in OECD countries, excluding the United States, will be significant, rising from about 11 percent of total electricity production in 1978 to the stated level in 1990.

With the exception of Iran, where the nuclear program virtually ceased to exist during 1979, EIA forecasts for non-OECD countries were essentially unchanged from the 1978 *Annual Report*. The nuclear forecast ranges in Table 2.15 reflect economic growth in South Korea and Taiwan that probably justify additional reactors above those currently ordered.

### Sensitivity Analysis

The high and low projection series provide a range of possible energy futures and the middle series provides a midrange outlook as stated. Questions on oil price impacts or possible nuclear moratoria can be addressed by analyzing the

results of the low-mid and the low-nuc projection series, respectively.

One approach to evaluating the effect of a world oil price change on the free world energy system is the concept of the system price elasticity. This elasticity may be approximated, for small relative changes, by the ratio of the relative change in quantity demanded to the relative change in world oil price, with substitution of fuels permitted. Such elasticities are given in Table 2.16 for three energy categories: all oil, gasoline, and residual fuel oil. They are presented for the three projection years, 1985, 1990, and 1995, and are broken out by selected regions.

Based on the results of Table 2.16, the lower gasoline elasticities for the United States, as compared with the other regions, are an indication of the reluctance of the U.S. drivers to forego the use of their automobiles. The U.S. residual fuel oil elasticity, however, rises sharply over the forecast period, indicating a willingness of industrial users to switch into substitute fuels. This switching of fuels is especially true for the electric utilities. In 1990, for example, a 10 percent increase in the

**Table 2.13 World Energy and Oil Consumption Growth Rates and Energy/Gross Domestic Product (GDP) Ratios: History and Midprice Projections**

Region or Country	Energy Growth Rate			Oil Growth Rate			Energy/GDP Ratios (1,000 Btu per constant 1975 U.S. dollars)					
	1960- 1973	1973- 1977	Midprice 1977- 1990	1960- 1973	1973- 1977	Midprice 1977- 1990	Midprice					
							1960	1973	1977	1985	1990	1995
United States <sup>a</sup> .....	4.2	0.6	1.2	4.5	1.7	-1.3	47.4	48.1	45.6	39.6	37.0	35.5
Canada.....	5.7	1.6	2.1	5.3	0.9	0.1	50.5	51.8	48.2	42.6	40.7	39.6
Japan.....	11.0	0.2	3.3	17.9	-0.9	0.9	28.5	30.8	27.4	24.6	25.5	24.6
Western Europe.....	5.5	0.0	0.5	10.4	-2.2	-1.2	28.6	31.2	28.9	23.0	22.3	21.5
Finland/Norway/Sweden.....	6.4	1.5	1.6	7.8	0.5	-0.6	26.6	33.2	33.1	28.2	27.4	26.1
United Kingdom/Ireland.....	2.1	-1.5	-0.3	6.5	-5.1	-0.6	49.0	42.6	39.5	32.0	30.4	28.6
Benelux/Denmark <sup>b</sup> .....	7.8	-1.6	0.6	10.8	-4.3	-1.1	28.1	40.5	34.5	26.2	25.7	25.9
West Germany.....	4.9	-0.1	0.8	11.9	-1.7	-1.6	25.8	26.9	25.2	21.1	20.6	20.1
France.....	6.3	-0.4	0.7	12.1	-3.1	-1.2	22.9	25.1	21.9	17.6	17.1	16.2
Austria/Switzerland.....	6.5	0.5	0.3	10.9	-2.4	-1.7	17.1	21.2	21.8	17.8	17.4	16.7
Spain/Portugal.....	8.5	3.5	0.6	13.1	2.8	-1.4	22.5	26.7	28.2	20.5	20.1	19.8
Italy.....	8.4	0.8	-0.3	11.5	-1.8	-1.8	24.1	35.4	33.8	25.3	24.2	23.9
Greece/Turkey.....	10.8	5.7	0.6	13.5	4.0	-1.3	17.9	27.5	26.7	20.4	19.7	18.4
Australia/New Zealand.....	5.5	4.3	1.5	6.7	3.0	-0.1	25.8	28.3	30.4	25.8	24.1	22.5
Total OECD.....	5.2	0.5	1.2	7.6	-0.2	-0.8	37.6	38.4	35.9	30.3	29.2	28.0
Total Non-OECD.....	6.9	4.7	5.5	7.4	4.8	4.6	36.1	28.3	27.9	28.0	27.8	27.1
OPEC.....	8.6	5.9	7.4	7.5	7.3	7.1	27.9	23.7	22.7	26.1	26.5	26.8
Other.....	6.5	4.4	4.9	7.4	4.1	3.6	38.3	29.7	29.8	28.6	28.2	27.2
Total Free World.....	5.4	1.1	2.1	7.6	0.6	0.4	37.4	36.6	34.4	29.8	28.8	27.8

<sup>a</sup>Includes Puerto Rico, Virgin Islands, and purchases for the Strategic Petroleum Reserve.

<sup>b</sup>Benelux countries are Belgium, the Netherlands, and Luxembourg.

Source: Historical estimates are based on data from U.S. Department of Energy, Energy Information Administration, *Annual Report to Congress*, 1979, Vol. 2, and *International Petroleum Annual*, various years; Organization for Economic Cooperation and Development, *Basic Energy Statistics*, data tape, and *Energy Statistics, 1975/1977*; United Nations, *World Energy Supplies*, data tape; Data Resources Inc., *World Data*, January 1979; and WEFA Inc./SRI, *World Economic Data Base*, Fall 1979.

**Table 2.14 World Energy Consumption and Production: Midprice Scenario Projections, 1985, 1990, and 1995 (Quadrillion Btu)**

	1977	1985	1990	1995
World Oil Price (1979 dollars per barrel)		32.00	37.00	41.00
<b>Consumption</b>				
United States <sup>a</sup>	77.0	82.6	89.8	97.4
Canada	8.6	10.0	11.3	12.9
Japan	15.4	19.7	23.6	29.1
Western Europe	54.0	53.3	57.3	63.3
France	8.0	8.2	8.8	10.3
Italy	6.4	5.8	6.1	6.7
United Kingdom/Ireland	9.8	9.1	9.4	10.2
West Germany	11.5	12.0	12.7	13.5
Australia/New Zealand	3.4	3.7	4.1	4.6
Total OECD	158.4	169.2	186.0	207.3
OPEC	6.3	11.7	15.8	20.9
Other Countries <sup>b</sup>	23.8	34.8	44.3	55.0
Total Consumption <sup>b,c</sup>	188.4	215.7	246.1	283.2
<b>Production</b>				
United States	60.3	70.9	79.4	87.6
Canada	8.9	10.2	11.8	12.8
Japan	1.8	2.9	3.8	4.9
Western Europe	23.5	30.3	32.0	32.7
France	1.9	2.8	3.2	3.8
Italy	1.1	1.3	1.3	1.3
United Kingdom/Ireland	7.0	10.1	10.1	10.1
West Germany	5.0	4.9	5.3	5.6
Australia/New Zealand	3.9	4.7	5.7	6.9
Total OECD	98.4	119.0	132.7	144.9
OPEC	67.4	59.5	66.3	80.7
Other Countries <sup>b</sup>	18.9	37.3	46.9	56.9
Total Production <sup>b,c</sup>	184.7	215.8	245.9	282.5
Net Exports from Communist Countries <sup>c,d</sup>	7.1	1.1	1.0	1.4
Stock Change and Discrepancy	(3.4)	0	0	0

<sup>a</sup>Includes Puerto Rico, Virgin Islands, and purchases for the Strategic Petroleum Reserve.

<sup>b</sup>Excludes Communist countries.

<sup>c</sup>Consumption may not equal production plus net imports from Communist countries because of rounding.

<sup>d</sup>The net energy exports from Communist countries for the midprice scenario consist of coal and natural gas.

Source: Data for 1977 are based on data from U.S. Department of Energy, Energy Information Administration, *Annual Report to Congress, 1979*, Vol. 2, and *International Petroleum Annual*, various years; Organization for Economic Cooperation and Development, *Energy Statistics, 1975/1977*; and United Nations, *World Energy Supplies*, data tape.

world oil price would facilitate an 8.5-percent decrease in the use of residual fuel in the United States but only 3.6 percent reduction for OECD as a whole. The elasticity for OPEC exports simply reflects the decrease in demand for OPEC oil by non-OPEC countries as the world oil price increases.

The impact on fossil energy consumption of an increase from \$27 to \$37 per barrel (37 percent) in the world real price of oil in 1990 is reflected by an expectant overall decrease of nearly 5 percent by OECD.

Although total energy consumption declines with the increase in the price of oil, the consumption of oil declines more sharply and is partly replaced by other fuels. The increased price impact is summarized as follows:

#### Energy Consumption Impact of a Change

	Non-U.S. OECD (percent change)	United States (percent change)
World Oil Price Change	37.0	37.0
Fossil Energy Consumption	-4.6	-4.4
Oil	-12.4	-10.8
Gas	10.1	-2.8
Coal	7.4	2.9

The significant jump in the use of coal for the OECD countries excluding the United States is largely a result of the flexibility of foreign dual-fired powerplants. The increase in natural gas use

**Table 2.15 Foreign Nuclear Generating Capacity: Actual and Potential, 1979 to 1995<sup>a</sup>**

Region or Country	1978	Projected		
		1985	1990	1995
<b>OECD (excluding the United States)<sup>b</sup></b>				
Australia/New Zealand.....	—	—	—	—
Austria/Switzerland.....	1.0	2.9	2.9	3.8-4.9
Benelux/Denmark.....	2.3	5.0-6.0	6.0	6.0-7.0
Canada.....	4.8	10.3	13.4-14.2	16.6-19.0
France.....	6.5	25.7-29.1	38.5-44.2	50.1-56.5
Germany.....	9.1	15.0-16.6	22.5-27.5	28.7-33.9
Greece/Turkey.....	—	—	—	1.0-1.6
Italy.....	0.6	1.4	3.4-4.3	6.4-9.5
Japan.....	10.9	17.8-19.5	24.5-30.9	40.8-46.2
Scandinavia.....	5.9	9.5	12.6-13.2	13.9-15.6
Spain/Portugal.....	1.1	7.4	9.3-13.2	13.2-17.8
United Kingdom/Ireland.....	5.9	11.8	11.6-13.1	13.4-17.6
Subtotal <sup>c</sup> .....	48.1	107-115	145-170	194-230
<b>Non-OECD</b>				
Argentina.....	0.3	0.9	1.5-2.1	3.3-3.9
Brazil.....	—	0.6	1.9-3.1	3.1-5.7
India.....	1.0	1.2-1.5	1.9-2.1	2.7-3.3
South Korea.....	0.6	1.8-2.7	5.5-7.4	9.3-13.5
Mexico.....	—	0.6	1.3-2.6	2.6-4.1
Pakistan.....	0.1	0.1	0.1-0.7	0.7-1.9
Philippines.....	—	—	0.6	0.6
South Africa.....	—	0.9-1.8	1.8-2.7	3.7-5.5
Taiwan.....	0.6	3.1-4.0	4.9-6.7	6.7-8.7
Yugoslavia.....	—	0.6	0.6-1.2	1.2-1.8
Subtotal <sup>c</sup> .....	2.6	10-13	20-30	34-49
<b>Total OECD and Non-OECD<sup>c</sup>.....</b>	<b>51.0</b>	<b>117-128</b>	<b>165-200</b>	<b>228-280</b>

<sup>a</sup>Gigawatts of capacity in commercial operation at the end of each forecast year.

<sup>b</sup>National and regional groupings as modeled in the EIA International Energy Evaluation System (IEES).

<sup>c</sup>Numbers may not add to totals due to independent rounding.

in these countries reflects the availability of natural gas in Europe and the diversification policy of Japan, which is reflected in the increased imports of liquefied natural gas (LNG).

The nuclear moratorium case, which differs from the midprice scenario in assuming that nuclear plants less than 10 percent complete will not be finished, was significant only in 1995. The moratorium indicates an increase in demand for OPEC oil of 0.2 million barrels per day. For the OECD, an increase of 0.4 percent in oil consumption, 6.9 percent in coal, and 0.9 percent in natural gas is projected for 1995.

In forecasting world oil markets, the EIA methodology has evolved from one that allowed a gap between the demand for OPEC oil and OPEC production capacity (*Annual Report to Congress, 1977*) and closed the gap through an assumption of market-clearing prices (*Annual Report to Congress, 1978*) to a methodology that now maintains that OPEC will change its prices in accordance with the market behavior and apparent conservationist's policies of several of its members. Since alternative methodologies affect world oil market forecasts significantly, the EIA and several other forecasts are significantly different.

## COMPARISON WITH OTHER FORECASTS

This section provides a comparison of the current EIA middle scenario forecast for 1990 with the corresponding projections from the 1977 and 1978 *Annual Report to Congress*. In addition, EIA's middle forecast is compared with recent forecasts made by others.

## Comparison with Previous EIA Forecasts

Table 2.17 presents the EIA midprice projection series from the 1977, 1978, and 1979 world oil market forecasts of consumption and production, by region, for 1990. The 1979 forecast of total energy consumption for the free world is 33 quadrillion Btu below the 1978 forecast. The

forecast of oil consumption has decreased by approximately 15 million barrels per day between the 1977 and 1978 *Annual Report*: of this total reduction, 7 million barrels was a result of higher prices; 2 million barrels a result of higher conservation; 3 million barrels, lower economic growth; and the remaining 3 million barrels, data and model updates. These differences are examined in more detail in the 1978 *Annual Report*. The free world oil consumption forecast for the 1979 *Annual Report* has decreased from last year's forecast by approximately 16 million barrels per day for 1990. Reductions that account for most of this decrease are 6 million barrels per day in the Other OECD region, almost 4 million barrels per day in the United States, and just over 3 million barrels in the Other Countries region.

The most important factor contributing to the decrease in free world oil consumption between the 1978 and 1979 forecasts is the higher world oil price projected for 1990. The price of oil in the midprice series has increased nearly 85 percent from \$20 (restated as 1979 U.S. dollars) per barrel in last year's *Annual Report* to \$37 per barrel in the current projection. The higher price decreases consumption both directly and indirectly. The indirect decrease is partly due to more effective, nonprice conservation measures required by government policies. Lower economic growth projections in this year's report also played a major role in changing the forecast. The remaining differences in the consumption forecasts are the result of data and methodology changes that have occurred over the past 12 months.

This year's demand forecasts for foreign countries are based on statistics for the 1960-77 period rather than the 1960-76 period used last year, and the U.S. data base is extended to include 1978. Numerous improvements have been made in the quality of the historical data series for the OECD countries. In forecasting OECD energy demands, individual economic activity variables were related more directly to energy growth in each economic sector.

In relation to the free world oil supply projections for 1990, the biggest change occurs in OPEC production in that OPEC is predicted to produce roughly 13 million barrels per day less than originally projected in the 1978 forecast. Despite the sharp drop in projected OPEC production and the sharp rise in world oil prices, the even larger drop in free world oil consumption leads to a decline in oil production forecasts for all other free world areas, relative to last year's projections.

### Comparison with Non-EIA Forecasts

A number of forecasts of the world energy situation have been published in the past few years, with several updated to reflect changed outlooks. Where available, the most current forecast has been reviewed.

Table 2.18 presents a comparison of seven prominent forecasts, including:

- *World Energy Outlook*, Exxon Corporation, December 1979

**Table 2.16 Sensitivity of Petroleum Demand to World Oil Price Increases**  
(Medium to Long-term System Elasticity<sup>a</sup>)

Region	1985			1990			1995		
	All Oil	Gasoline	Residual	All Oil	Gasoline	Residual	All Oil	Gasoline	Residual
United States .....	-0.33	-0.18	-0.47	-0.35	-0.22	-0.85	-0.44	-0.28	-1.42
Japan .....	-0.46	-0.44	-0.26	-0.43	-0.53	-0.39	-0.41	-0.68	-0.37
West Germany .....	-0.37	-0.44	-0.34	-0.52	-0.54	-0.41	-0.61	-0.67	-0.44
France .....	-0.29	-0.39	-0.34	-0.41	-0.48	-0.41	-0.45	-0.61	-0.40
United Kingdom <sup>b</sup> .....	-0.58	-0.51	-0.45	-0.40	-0.60	-0.57	-0.39	-0.74	-0.47
Italy .....	-0.19	-0.33	-0.24	-0.33	-0.42	-0.50	-0.36	-0.55	-0.43
OECD Total .....	-0.35	-0.28	-0.27	-0.39	-0.34	-0.36	-0.43	-0.43	-0.32
Developing Countries ..	-0.34	-0.34	-0.28	-0.35	-0.33	-0.34	-0.36	-0.37	-0.28
OPEC Exports <sup>c</sup> .....	-0.78	--	--	-0.94	--	--	-0.98	--	--

<sup>a</sup>The system elasticity may be approximated (for small changes) as the relative change in quantity divided by the relative change in price, with substitution of fuels permitted. These quantities were computed for each projection year from the projections made for two distinct projection series, midprice (or middle) and low-mid. The low-mid series differs from the midprice only in the assumption of the world oil price.

<sup>b</sup>Includes Ireland.

<sup>c</sup>The elasticities in this row are for demand for OPEC oil exports as opposed to demand by OPEC.

- "World Oil Project Model," Massachusetts Institute of Technology (MIT) Energy Laboratory, March 1980
- *The Pace Energy and Petrochemical Outlook to 2000*, The Pace Company Consultants and Engineers, Inc., October 1979
- *World Energy Study: Summary and Conclusions*, SRI International, May 1979
- "Non-Communist World Energy and Oil," Standard Oil Company of California, March 1980
- "World Energy Forecasts: 1985 and 1990," Shell Oil Company, April 8, 1980.

The world energy, oil consumption, and oil production estimates are based on differing assumptions about such factors as economic growth and world oil prices. (See Table 2.18.) The average, annual growth rate for world gross national product varies from the Exxon estimate of 3.5 percent for 1978–2000 to the SRI estimate of 4.1 percent for 1975–2000. All forecasts assume that world economic growth will be slower than the 5 percent annual rate for the 1965–73 period. Explicit in some forecasts and implicit in all forecasts is

the assumption that economic activity and, therefore, the demand for energy will grow at a faster rate in the developing countries than in the industrialized countries.

World oil price assumptions vary considerably, depending upon whether the respective forecasts were made before or after the doubling of OPEC prices in late 1979. For example, the SRI forecast, the oldest of those presented, assumes that the price of oil measured in 1975 constant dollars declines to \$10.20 in 1980 and then increases at an annual rate of 1.5 percent to \$13.50 by the year 2000. In contrast, the December 1979 Exxon forecast is based on an OPEC sales price of \$18 in 1979 dollars. Their assumed oil prices in 1979 dollars for 1985 and 1990 are \$25 and \$28, respectively. The EIA midprice forecast includes the total 1979 OPEC price increases in its price assumptions. The differences in the various price assumptions reflect the uncertainty associated with OPEC pricing policies.

The most important observation from this comparison is the range of uncertainty associated with the demand for OPEC oil. For the forecasts surveyed, the overall range of consumption of

**Table 2.17 Comparison with 1977 and 1978 EIA Annual Report: Midprice Projections, 1990**

Element of Comparison	United States <sup>a</sup>	Japan	Other OECD	OPEC	Other Countries	Free World <sup>b</sup>
<b>Energy Consumption</b> (quadrillion Btu)						
1977 Annual Report.....	109	33	82	18	79	321
1978 Annual Report.....	103	26	67	20	65	280
1979 Annual Report.....	90	24	57	16	60	247
<b>Oil Consumption</b> (million barrels per day)						
1977 Annual Report.....	23.9	11.5	26.5	4.8	16.2	82.9
1978 Annual Report.....	19.6	7.9	21.1	6.4	13.4	68.4
1979 Annual Report.....	15.7	6.3	15.0	5.0	10.3	52.3
	United States	Mexico	Non-OPEC	Other Non-OPEC	CPE Exports	Free World
<b>Oil Production</b> (million barrels per day)						
1977 Annual Report.....	9.8	3.1	11.5	61.0	-2.5	82.9
1978 Annual Report.....	11.2	4.1	13.4	39.7	0	68.4
1979 Annual Report.....	9.6	4.0	12.4	26.3	0	52.3
	1977 Annual Report		1978 Annual Report		1979 Annual Report	
<b>World Oil Price</b> (1979 dollars per barrel).....	16.70		20.10		37.00	

<sup>a</sup>Includes Puerto Rico and Virgin Islands.

<sup>b</sup>Excludes the Communist countries. Numbers may not add to totals due to independent rounding.

<sup>c</sup>Includes only European OECD countries. Energy consumption for Australia, Canada, and New Zealand is included in the Other Countries category.

<sup>d</sup>Includes energy consumption for Australia, Canada, and New Zealand.

CPE = Centrally Planned Economies.

**Table 2.18 Free World Energy Forecasts: Comparison of EIA Projections with Other Projections for 1985 to 1990**  
(Million Barrels per Day of Crude Oil Equivalent)

Organizational Forecasts	Consumption		Oil Production		
	Energy	Oil	OPEC	Other	CPE Export
1978 Actual .....	89	50	31	18	1.0
1985 Forecasts					
EIA Midprice Scenario .....	102	49	25	24	0
MIT (March 1980) .....	—	52	28	23	0.5
Pace (October 1979) .....	109	57	30	27	0.4
SRI International (May 1979) .....	<sup>a</sup> 120	<sup>a</sup> 59	34	25	<sup>a</sup> 0.1
Standard Oil of California (March 1980) .....	117	<sup>b</sup> 59	34	25	0.6
Shell (April 1980) .....	—	56	33	23	0
1990 Forecasts					
EIA Midprice Scenario .....	116	52	26	26	0
Exxon (December 1979) .....	129	60	33	26	1.0
MIT (March 1980) .....	—	55	31	24	0
Pace (October 1979) .....	125	63	32	31	-0.1
Standard Oil of California (March 1980) .....	134	<sup>b</sup> 65	39	26	0
Shell (April 1980) .....	—	58	33	25	0

<sup>a</sup>Converted from quadrillion Btu.

<sup>b</sup>Oil consumption and production are not equal because production excludes alcohol and process gains; these are included in consumption.

CPE = Centrally Planned Economies

OPEC oil is 25 to 34 million barrels per day in 1985 and 26 to 39 million barrels per day in 1990. The range of uncertainty in the EIA projections is somewhat smaller, but is, in part, a result of the differing oil prices estimated in the EIA projections and does not imply low uncertainty in the underlying consumption or production forecasts.

## SUMMARY

Forecasts of the world energy market are uncertain. Their use should always be made in the context of the assumptions. Much of the doubt is caused by uncertainty pertaining to such critical

factors as economic growth, energy conservation, the extent of energy resources, OPEC behavior, and the political stability of producer countries—especially the lack of it in the Middle East. This assessment attempts to capture the range of this uncertainty. Even this attempt may prove unsuccessful because of the tremendous volatility that has recently been exhibited in the world price of oil. The extent to which this will continue in the future is difficult to estimate. OPEC's pricing strategy of the recent past does not reflect a strong, consistent pattern of behavior for quantitative analysis upon which reliable forecasts can be based.



### 3. Short-Term Energy Supply and Demand: 1980-81

#### INTRODUCTION

During 1978 and 1979, the Energy Information Administration (EIA) published a series of Analysis Reports containing short-term forecasts for petroleum. The *Short-Term Energy Outlook*, October 1979, expanded the analysis from petroleum to all fuels and the *Short-Term Energy Outlook*, February 1980, was the first quarterly publication of this series.<sup>1</sup>

Each section of this chapter includes both historical and forecast data with analyses of current trends in the data. All data, both historical and projected, are generated from the report writer programs of the Short-Term Integrated Forecasting System (STIFS). The STIFS is a computer system consisting of a national monthly data base and a set of computer programs that aggregate data to quarterly and annual totals and convert input data into standard physical units and common heat values (Btu). The STIFS provides an integrating framework that forces consistency between historic data and the forecasts.

Slight differences may occur between historical data appearing in this chapter and in other volumes or chapters of this *Annual Report to Congress*. The main sources of these discrepancies are assumptions about conversion factors for coal and petroleum products and the inclusion or exclusion of various energy items of relatively small magnitude—such as hydrogen used in the refining process.

Single point forecasts are not presented because of the uncertainties inherent in the key factors affecting energy supply and demand: economic growth, energy prices, weather conditions, and the way gasoline demand changes in response to price changes. A series of forecasts reflect these uncertainties as variations from a set of base-case

projections for major energy products. The base case assumes continuation of current expectations for these key variables; however, the alternative assumptions are used to generate sensitivity cases. The purpose of the sensitivity cases is to illustrate the range of uncertainty in the projections that arises from the uncertainty in the assumed value of a single key factor.

A concurrent combination of extreme values of these variables could occur, but it would be highly unlikely. A first order approximation to the likely effects of concurrent variations is obtained by combining the differential effects of the scenarios by the root mean square (RMS) method, discussed later.

#### Recent History

The decade of the 1970's ended with uncertainty about world oil supply, rising petroleum prices, and discouraging economic prospects in the United States and other major industrial countries. In addition, the long-projected recession in the U.S. economy now seems to be emerging. Although the Organization of Petroleum Exporting Countries (OPEC) increased crude oil prices and cutbacks of crude oil exports were scheduled or threatened in several producing countries, a world oil surplus in early 1980 was growing. However, further disruptions of oil supply, higher energy prices, and lower economic activity are likely future combinations. Consequently, sensitivity cases become an integral and highly important part of the short-term projections.

In reference to the history of the past decade, the sequence of higher oil prices, more inflation, world financial disequilibria, and lower economic growth is becoming an established pattern. This sequence suggests that the present short-term problems are simply reinforcing adverse trends that originated in earlier crises. It is expected, therefore, that energy producers and consumers will incorporate past experience in reaction to

<sup>1</sup> Short-Term Analysis Division, Office of Integrative Analysis, Energy Information Administration, *Short-Term Energy Outlook*, October 1979, DOE/EIA-0202/1, February 1980, DOE/EIA-0202/2, (Washington, D.C.: U.S. Department of Energy, 1979, 1980).

current problems and will move the Nation further in the direction of longer-term adjustments to the changing energy situation.

For example, the long-overdue downturn in motor gasoline use was actually triggered by physical shortages in 1979, but it now appears to reflect a more fundamental change in motorists' purchases and automobile use. An analysis of motor vehicle sales in the 1979 model year indicates that the composition of new car sales shifted toward smaller, more fuel-efficient cars. Faced with further sharp increases in the prices of gasoline and automobiles and continuing concern about availability of supply, motorists are likely to continue the shift to smaller cars and to use less gasoline.

## Energy Projections

Table 3.1 shows that the declines projected for motor gasoline use also extend to other petroleum products. "Total petroleum products supplied" in the base case is projected to decline from 18.3 million barrels per day in 1979 to 17.6 million barrels per day in 1980 and 17.4 million barrels per day in 1981. Distillate fuel oil in the base case, which includes motor diesel fuel as well as industrial and home heating oils, is projected down from 3.3 million barrels per day estimated for 1979 to 3.2 million barrels per day in 1980 and 1981. This projection reflects the impact of lower economic activity and higher prices. In the short run, the residential use of heating oil does not change

**Table 3.1 Energy Supply by Major Sources, Annual 1978-1981**

Total Energy	Annual Total				Percentage Change from Prior Year		
	1978	1979	1980	1981	1979	1980	1981
	(quadrillion Btu)						
Domestic Production .....	61.59	63.24	63.14	63.67	2.7	-0.2	0.8
Net Imports .....	16.85	16.07	14.84	14.69	-4.6	-7.7	-1.0
Stock Withdrawals .....	0.36	-0.54	-0.04	-0.22	—	—	—
Total Available .....	78.80	78.76	77.94	78.13	-0.1	-1.0	0.2
Petroleum .....	38.02	36.71	35.28	34.75	-3.4	-3.9	-1.5
Natural Gas .....	20.30	20.13	20.84	20.39	-0.8	3.5	-2.2
Coal .....	14.61	15.29	15.61	16.58	4.7	2.1	6.2
Other .....	6.04	5.82	6.08	6.54	-3.6	4.5	7.6
	(million tons)						
Coal							
Consumption .....	644	678	699	740	5.3	3.1	5.9
Electric Utility .....	481	529	551	592	10.0	4.2	7.4
Non-Utility .....	163	149	148	148	-8.6	-0.7	0.0
	(trillion cubic feet)						
Natural Gas Consumption .....	19.87	19.71	20.59	20.13	-0.8	4.5	-2.2
	(billion kilowatt-hours)						
Nuclear Generation .....	276	255	273	315	-7.6	7.1	15.4
Hydro Generation .....	280	280	287	287	0	2.5	0
	(million barrels per day)						
Petroleum							
Crude Oil Production .....	8.70	8.51	8.55	8.38	-2.2	0.5	-2.0
Other Liquids Supply .....	2.10	2.19	2.11	2.09	4.3	-3.7	-0.9
Total Domestic .....	10.80	10.70	10.66	10.47	-0.9	-0.4	-1.8
Net Imports .....	7.84	7.74	7.03	6.94	-1.3	-9.2	-1.3
Stock Withdrawals .....	0.26	-0.10	-0.10	-0.03	—	—	—
Total Available Product Supplied .....	18.90	18.34	17.58	17.38	-3.0	-4.1	-1.1
Motor Gasoline .....	7.41	7.03	6.68	6.61	-5.1	-5.0	-1.0
Distillate Fuel Oil .....	3.43	3.30	3.19	3.23	-3.8	-3.3	1.3
Residual Fuel Oil .....	3.02	2.79	2.54	2.31	-7.6	-9.0	-9.1
Other .....	4.99	5.28	5.17	5.23	5.8	-2.1	1.2

Note: Historical data in this table may differ from comparable data in Volume 2 due to rounding error in cumulating from monthly data or to alternative methods of handling data on stocks, converting to Btu, or other similar computational factors.

substantially. It is not economical in most instances for residential users to change furnace equipment in response to price increases. However, a combination of strenuous efforts to conserve, even to the point of reducing levels of comfort, and the use of wood and other substitute fuels could further lower the levels of demand.

The reductions in use of residual fuel oil are potentially much greater than for other petroleum products because substitutes are more attractive at current high oil prices. The base-case projection shows the 1980 residual fuel oil demand down 9 percent from the estimated 1979 levels and the 1981 demand down a further 9 percent from 1980.

Reductions in petroleum demand are largely reflected in imports. Total petroleum net imports in the base case are projected to decline by 10 percent from 1979 to 1981. Foreign trade in other fuels is small relative to oil. The projected net imports of all energy declines by 9 percent from 1979 to 1981.

Although petroleum supply and use have decreased since 1978, coal production and consumption are now higher. Despite forecasts of lower economic growth, additional coal will be used in electric power generation and total coal production is projected to increase to 800 million tons in 1981. Nuclear generation is also projected to increase in both 1980 and 1981 in the base case.

## FORECAST ASSUMPTIONS

The most crucial and influential of the numerous variables involved in energy projections are those relating to economic activity, levels of energy prices, and the severity of the weather. A selected set of "most probable" or "normal" values for these key variables are used to develop energy projections for a base case. However, in view of the high degree of uncertainty involved in forecasts of these major determinants, alternative high and low values (assumed for each of the key driving variables) are used in sensitivity analyses to show likely deviations above or below the base-case energy projections. Uncertainty about the price elasticity of the demand for gasoline (the ratio of the percentage change in quantity demanded to the percentage change in price for gasoline demand) in a market characterized by rapidly increasing prices as well as the uncertainty in completion of nuclear plants under the threat of safety or environmental shutdowns are also reflected in special scenarios.

## Base and Sensitivity Case Assumptions

Table 3.2 presents base-case values for forecasts of economic activity, imported and domestic crude oil prices, and the weather. Although details are not included, the series indicate the nature of the underlying forecasts and general trends for key variables.

The macroeconomic forecasts for the base case are from a modification of the Data Resources, Incorporated (DRI) scenario identified as *MARCONTROL MOD 1*. This forecast incorporates the base case projections for world oil prices EIA made for this report. The economic trend in *MARCONTROL MOD 1* is downward after the first quarter of 1980, which is forecast as a recession year. However, an economic upturn in the first quarter of 1981 is forecast to continue with the real gross national product (GNP) in the last quarter of 1981 expected to be 4.0 percent above the last quarter of 1980.

Table 3.2 includes projections of imported crude oil costs and the average cost of all crude oil to domestic refiners through the fourth quarter of 1981. These costs are basic elements in determining prices for specific petroleum products as projected. The average annual cost in current dollars of crude oil imported into the United States is assumed to increase to \$33.51 per barrel in 1980 and \$36.85 in 1981, compared with an average increase of \$21.54 in 1979 and \$14.57 in 1978. Because phased deregulation of domestic crude oil prices will raise domestic prices, the average cost of all crude oil (foreign and domestic) to U.S. refiners is projected to increase from \$17.67 per barrel in 1979 to \$28.36 in 1980 and to \$35.98 in 1981.

The severity of weather conditions is an important factor in energy projections. The base-case assumptions are that temperatures, measured by population-weighted, national heating degree days in the winter and cooling degree days in the summer, will follow the average pattern for the last 30 years.

For this report, the sensitivity cases have been developed using prespecified variations from the economic, price, and weather assumptions used in the base case. These variations are illustrated in Table 3.2 as alternative values for the base-case assumptions.

In the economic sensitivity analysis, the range of uncertainty in real Disposable Personal Income (DPI) is assumed to be plus or minus an estimate

**Table 3.2 Economic, Price, and Weather Assumptions for Short-Term Energy Projections**

Base Case	1978					1979				
	Quarter				Annual Total	Quarter				Annual Total
	1st	2nd	3rd	4th		1st	2nd	3rd	4th	
(billion 1972 dollars)										
Economic Assumptions										
Real Gross National Product*(GNP) .....	1,368	1,395	1,407	1,427	1,399	1,431	1,422	1,433	1,440	1,432
Percent Change from										
Prior Year (percent) .....	4.0	4.8	3.9	4.8	4.4	4.6	1.9	1.8	1.0	2.4
Prior Quarter (percent) <sup>a</sup> .....	1.9	8.3	3.5	5.6	NA	1.1	-2.3	3.1	2.0	NA
GNP Implicit Price Deflator <sup>a</sup> .....	147.1	150.8	153.5	156.7	152.1	160.2	163.8	167.2	170.6	165.5
(Index, 1972 = 100)										
Percent Change from										
Prior Year (percent) .....	6.3	7.0	7.6	8.1	7.3	8.9	8.6	8.9	8.9	8.8
Prior Quarter (percent) .....	6.3	10.6	7.2	8.7	NA	9.3	9.3	8.5	8.4	NA
Real Disposable Personal Income <sup>a</sup> .....	957	966	976	992	972	997	993	993	995	995
Percent Change from										
Prior Year (percent) .....	5.4	4.8	4.3	4.2	4.6	4.2	2.8	1.8	0.3	2.2
Prior Quarter (percent) .....	2.0	4.0	4.2	2.1	NA	-2.1	-1.6	0	0.8	NA
(U.S. dollars per barrel)										
Oil Price Assumptions										
Imported Crude Oil <sup>b</sup> .....	14.50	14.49	14.49	14.77	14.57	15.93	19.20	24.04	26.99	21.54
U.S. Refiners' Cost <sup>c</sup> .....	12.18	12.34	12.49	12.77	12.45	13.41	15.64	19.49	22.12	17.67
(number of degree days)										
Weather Assumptions <sup>d</sup>										
Heating Degree Days .....	2,834	566	84	1,718	5,202	2,727	582	74	1,674	5,057
Cooling Degree Days .....	13	311	761	63	1,148	19	277	673	61	1,030
Sensitivity Assumptions										
Economic Variations										
(billion 1972 dollars)										
Real Disposable Personal Income <sup>a</sup>										
High .....	—	—	—	—	—	—	—	—	—	—
Low .....	—	—	—	—	—	—	—	—	—	—
Oil Price Variations										
(U.S. dollars per barrel)										
Imported Crude Oil										
High .....	—	—	—	—	—	—	—	—	—	—
Low .....	—	—	—	—	—	—	—	—	—	—
U.S. Refiners' Cost										
High .....	—	—	—	—	—	—	—	—	—	—
Low .....	—	—	—	—	—	—	—	—	—	—
Weather Variations <sup>d</sup>										
(number of degree days)										
Adverse										
Heating Degree Days .....	—	—	—	—	—	—	—	—	—	—
Cooling Degree Days .....	—	—	—	—	—	—	—	—	—	—
Favorable										
Heating Degree Days .....	—	—	—	—	—	—	—	—	—	—
Cooling Degree Days .....	—	—	—	—	—	—	—	—	—	—

\*Data are at seasonally adjusted annual rates.

<sup>b</sup>Cost of imported crude oil to U.S. refiners, quarter and annual averages.

<sup>c</sup>U.S. refiners' acquisition costs of foreign and domestic crude oil, quarter and annual averages.

<sup>d</sup>Degree-day data are weighted by population.

NA = Not applicable.

Sources: Economic Forecasts: Data Resources, Inc., "U.S. Forecast Summary," February 1980. Historical Economic Data: Council of Economic Advisors, "Economic Indicators" (prepared for the Joint Economic Committee, U.S. Congress), October 1979. National Climatic Center, U.S. Department of Commerce, "State, Regional, and National Degree Days."

1980					1981				
Quarter				Annual Total	Quarter				Annual Total
1st	2nd	3rd	4th		1st	2nd	3rd	4th	
(billion 1972 dollars)									
1,446	1,438	1,425	1,423	1,433	1,431	1,444	1,461	1,479	1,454
1.0	1.0	-0.6	-1.2	0.1	-1.0	0.4	2.6	3.9	1.5
1.7	-2.2	-3.6	0.6	NA	2.2	3.6	4.7	4.9	NA
174.1	179.5	183.6	187.8	181.6	191.9	196.3	200.8	205.7	198.7
8.7	9.6	9.8	9.4	9.6	9.3	9.9	9.7	9.6	9.9
8.0	8.9	9.1	9.2	NA	8.9	9.2	9.2	8.8	NA
991	990	990	991	990	997	1,005	1,016	1,026	1,011
-0.6	-0.3	-0.3	-0.4	-0.5	0.6	1.5	2.7	3.6	2.1
-1.6	-0.4	0.0	0.4	NA	2.8	3.2	4.3	3.9	NA
(U.S. dollars per barrel)									
32.16	33.17	33.95	34.76	33.51	35.58	36.41	37.27	38.15	36.85
25.81	27.51	29.17	30.95	28.36	32.70	34.71	36.91	39.61	35.98
(number of degree days)									
2,399	543	92	1,674	4,708	2,399	543	92	1,674	4,708
27	327	744	61	1,159	27	327	774	61	1,159
(billion 1972 dollars)									
997	1,004	1,006	1,012	1,004	1,022	1,033	1,050	1,062	1,042
985	977	973	969	976	973	977	982	990	980
(U.S. dollars per barrel)									
34.32	36.49	37.35	38.23	36.60	39.13	40.06	41.00	41.97	40.54
31.16	31.66	31.66	31.66	31.54	31.66	31.66	31.66	31.66	31.66
27.12	29.65	31.54	33.56	30.47	35.56	37.86	40.37	43.29	39.27
25.22	26.53	27.57	28.61	26.98	29.55	30.60	31.70	33.34	31.30
(number of degree days)									
2,515	—	—	1,755	4,905	2,515	—	—	1,755	4,905
—	350	797	—	1,235	—	350	797	—	1,235
2,283	—	—	1,594	4,512	2,283	—	—	1,594	4,512
—	304	691	—	1,083	—	304	691	—	1,083

of the average percentage error from the base-case forecasts. The average percentage errors in the DPI is from previous DRI forecasts for similar time periods that are applied to reflect possible deviations from the fourth quarter 1979 data through each quarter to the end of 1981. This error band is illustrated in percentage terms in Table 3.2. The DPI is a key variable used in projecting petroleum demand.

Crude oil price paths were estimated on the basis of assumed variations in world oil consumption and in price and production policies of the oil-exporting countries. Because of instability in the current world oil situation, the price paths indicated in the sensitivity assumptions show wide variations from the base-case projection, especially on the high side. (See Table 3.3.)

For the weather sensitivity analysis, the normal-level assumptions for the base case, indicated by heating and cooling degree days, are varied to reflect plus or minus one standard deviation of total degree days over the season. This

assumption results in about a 5-percent variation from normal for heating degree days during the winter season and plus or minus about a 7-percent variation for cooling degree days during the spring and summer months.

Specialized scenarios were also constructed to reflect uncertainty in gasoline demand and startup dates for new nuclear plants. The current, rapidly increasing price of gasoline has created an unsettled market in the demand for that product. How consumers will react to higher gasoline prices is measured in terms of an expected price elasticity of demand, the assumed percentage change in demand for a 1-percent change in price. In the base-case scenario, the 1-month price elasticity is assumed to be -0.08 with a lagged response in subsequent months. The overall average elasticity over the 12 months of 1980 is -0.15. This increasing cumulative elasticity reflects the belief that the short-term price elasticities are smaller than in the longer term. Low- and high-demand scenarios are specified for a price elasticity of 50 percent above

**Table 3.3 Short-Term Energy Prices: History and Projections, 1978-1981**

Energy Products	History									
	1978					1979				
	Quarter				Annual Average	Quarter				Annual Average
1st	2nd	3rd	4th	1st		2nd	3rd	4th		
<b>Petroleum</b>										
Gasoline <sup>a,b</sup> .....	61.7	62.6	65.3	66.7	64.1	70.3	81.4	95.0	<sup>c</sup> 101.3	<sup>c</sup> 87.0
No. 2 Heating Oil (retail) <sup>b</sup> .....	48.6	48.4	48.5	51.4	49.2	56.2	64.8	77.8	<sup>c</sup> 83.9	<sup>c</sup> 70.7
No. 2 Heating Oil (wholesale) <sup>b</sup> .....	36.6	36.0	36.2	39.3	37.0	43.4	56.1	67.1	<sup>c</sup> 71.7	<sup>c</sup> 59.6
No. 6 Residual Fuel Oil <sup>a,f</sup> .....	11.71	12.03	11.33	12.84	11.98	14.20	16.89	20.67	<sup>c</sup> 24.30	<sup>c</sup> 19.01
Kerosene-Based Jet Fuel <sup>b</sup> .....	38.4	38.7	39.2	39.4	38.9	40.5	48.2	61.6	<sup>c</sup> 70.3	<sup>c</sup> 55.2
<b>Other</b>										
Coal (delivered to utilities) <sup>a,h</sup> .....	105.0	111.2	110.5	115.2	110.5	115.7	121.8	<sup>c</sup> 123.3	<sup>c</sup> 125.9	<sup>c</sup> 121.7
Natural Gas (residential) <sup>g</sup> .....	243.9	252.7	NA	288.0	261.5	297.2	312.4	334.5	<sup>c</sup> 345.8	<sup>c</sup> 322.5
Natural Gas (delivered to utilities) <sup>g</sup> .....	136.2	144.3	148.6	142.5	142.9	157.4	173.7	181.1	<sup>c</sup> 188.8	<sup>c</sup> 175.2
Electricity (residential).....	4.00	4.44	4.50	4.36	4.31	4.15	4.69	4.93	<sup>c</sup> 4.83	<sup>c</sup> 4.65

<sup>a</sup>Regular leaded gasoline at full-service pumps.

<sup>b</sup>Cents per gallon.

<sup>c</sup>Preliminary.

<sup>d</sup>Estimated.

<sup>e</sup>Wholesale residual fuel oil, 0.31 percent-to-1.0 percent sulfur content.

<sup>f</sup>Dollars per barrel.

<sup>g</sup>Cents per million Btu.

<sup>h</sup>Annual projections only.

<sup>i</sup>Cents per thousand cubic feet.

<sup>j</sup>Cents per kilowatt hour.

Note: Projections are designed as L = Low, M = Medium, and H = High and refer to the crude oil price scenarios discussed in Section 2, Part B.

and below the base-case elasticity. Two scenarios have been constructed to bracket the uncertainty in starting new nuclear plants. The base-case scenario includes normal startups under current law, and the low case includes a further postponement of all new openings through the forecast period.

The method used to estimate the combined effects of all of the uncertainties described above is termed the "root mean square" procedure. The RMS procedure provides only a rough approximation of the total uncertainty because it makes the

simplifying assumptions that the sources of uncertainty are statistically independent and that their impacts are additive. Although these assumptions clearly do not hold exactly, they are closely approximated within the range of variables addressed in this chapter's short-term energy projections. Low and high demands for total energy, total petroleum, and the major petroleum products were calculated. The RMS calculation of each combined uncertainty range is accomplished by taking the square root of the sum of the squares of the individual ranges in the economy, the weather,

**Table 3.3 Short-Term Energy Prices: History and Projections, 1978-1981 (Continued)**

Energy Products	Scenario	Projections									
		1980					1981				
		1st	2nd	3rd	4th	Annual Average	1st	2nd	3rd	4th	Annual Average
<b>Petroleum</b>											
Gasoline <sup>a,b</sup> .....	L	116.0	127.1	135.0	137.6	128.9	140.2	142.8	145.7	149.8	144.6
	M	116.0	129.0	139.6	145.4	135.5	151.9	158.4	165.7	175.2	162.8
	H	121.5	141.0	153.3	161.0	144.2	169.5	178.0	187.6	199.3	183.6
No. 2 Heating Oil (retail) <sup>b</sup> .....	L	92.7	96.6	99.3	101.6	97.5	104.0	106.3	109.0	112.7	108.0
	M	94.1	100.1	105.0	109.9	102.3	115.1	120.4	126.6	133.9	124.0
	H	95.8	105.8	111.8	117.6	107.8	123.8	130.3	137.6	146.1	134.4
No. 2 Heating Oil (wholesale) <sup>b,c</sup> ...	L	80.1	84.1	86.8	89.1	85.0	91.5	93.8	96.5	100.2	95.5
	M	81.5	87.0	91.6	96.2	89.1	101.0	106.1	111.8	118.9	109.4
	H	83.2	92.4	97.9	103.3	94.2	109.0	115.0	121.8	129.8	118.9
No. 6 Residual Fuel Oil <sup>c,d</sup> .....	L	21.22	20.84	20.51	21.05	20.91	22.93	21.74	21.40	21.98	22.01
	M	25.21	26.14	26.80	28.01	26.54	29.99	30.29	31.16	32.74	31.05
	H	29.64	33.29	34.71	36.34	33.50	37.96	39.60	41.48	43.66	40.67
Kerosene-Based Jet Fuel <sup>b</sup> .....	L	78.7	82.7	85.4	87.7	83.6	90.1	92.4	95.1	98.8	94.1
	M	80.1	85.6	90.1	94.7	87.6	99.4	104.5	110.2	117.2	107.8
	H	81.8	90.9	96.4	101.7	92.7	107.3	113.2	120.0	127.9	117.1
<b>Other</b>											
Coal (delivered to utilities) <sup>e,f</sup> .....	L	127.6	130.5	133.7	137.2	132.2	140.8	144.4	148.2	152.1	146.4
	M	128.9	132.1	135.6	139.3	134.0	143.1	147.1	151.1	155.3	149.2
	H	130.4	133.7	137.5	141.5	135.8	145.6	149.9	154.3	158.8	152.2
Natural Gas (residential) <sup>g</sup> .....	L	338.0	349.8	361.5	373.8	355.7	385.5	397.6	410.1	423.5	404.2
	M	355.7	368.2	380.5	393.4	374.5	405.8	418.6	431.7	445.8	425.5
	H	373.5	386.6	399.6	413.1	393.2	426.1	439.5	453.2	468.1	446.8
Natural Gas (delivered to utilities) <sup>g</sup> .....	L	185.8	193.6	201.4	209.6	197.6	217.6	225.7	234.2	243.2	230.2
	M	195.7	203.8	212.0	220.6	208.0	229.0	237.6	246.6	256.1	242.3
	H	205.3	214.0	222.6	231.7	218.4	240.4	249.5	258.8	268.9	254.4
Electricity (residential) <sup>h</sup> .....	L	4.56	4.88	5.02	4.86	4.83	4.93	5.21	5.38	5.20	5.18
	M	4.82	5.14	5.35	5.19	5.12	5.37	5.62	5.88	5.70	5.64
	H	5.11	5.49	5.76	5.57	5.48	5.85	6.08	6.41	6.20	6.14

<sup>a</sup>Regular leaded gasoline at full-service pumps.

<sup>b</sup>Cents per gallon.

<sup>c</sup>Wholesale residual fuel oil, 0.31 percent-to-1.0 percent sulfur content.

<sup>d</sup>Dollars per barrel.

<sup>e</sup>Cents per million Btu.

<sup>f</sup>Annual projections only.

<sup>g</sup>Cents per thousand cubic feet.

<sup>h</sup>Cents per kilowatt hour.

Note: Projections are designed as L = Low, M = Medium, and H = High and refer to the crude oil price scenarios discussed in Section 2, Part B.

the level of price, and, for gasoline, the degree of demand response to changes in prices.

## ENERGY PRICES

Table 3.3 presents energy price projections on a national average basis expressed in current dollars. All applicable taxes are included in the projections to the same extent that they are included in the historical data that EIA publishes. Generally, petroleum product prices are projected to increase because of higher crude oil costs and increases in gross margins by refiners and marketers.<sup>2</sup>

Price projections for petroleum products, except gasoline and residual fuel oil, are based on a straight cost pass-through of increased crude oil costs and three sets of assumptions regarding refiners' and marketers' gross margins.<sup>3</sup> Gasoline price projections are adjusted to account for the effects of the new fee for crude oil imports and its impact on gasoline prices as well as the gasoline "tilt" regulations. Residual fuel oil prices are assumed to be lower because of increased revenues from gasoline and a very soft market for heavy fuel oil. To the extent that market conditions and price regulations permit, prices could increase above these projections in a period of shortage or in response to unusual short-term increases in demand. In a surplus situation, market conditions might not sustain a full cost pass-through to consumers. Consequently, prices might not reach the levels forecast in this table.

### Crude Oil Price Assumptions

This report bases price projections on expected changes in refiners' crude oil costs, along with the escalation of other costs in the refining and distribution of petroleum products. Crude oil costs reflect both changes in world oil prices and changes in the price of domestic crude oil under the phased decontrol program as domestic crude oil prices move toward world price levels.

The methodology used to estimate world oil

<sup>2</sup> Refiners' margins are defined as the difference between refiners' crude oil costs and refiners' prices, but marketers' margins are defined as the difference between the cost of acquiring their products and their selling price. Margins include profit, labor, and other nonproduct costs.

<sup>3</sup> See section "Projections of Petroleum Product Prices" below.

prices is to simulate a number of international scenarios and to construct three oil price paths over time (low, middle, and high). This methodology is fully discussed in Chapter 2. As explained in that chapter, the variables addressed in the international oil scenarios performed by EIA's International Energy Analysis Division include:

- Demand in foreign countries
- Production in OPEC and non-OPEC countries
- Disruptions in oil supply
- Net imports of oil to the United States.

The Department of Energy's (DOE) Office of International Affairs provided the foreign oil supply projections. The most current OPEC price projections are rather pessimistic, reflecting the substantial changes in the supply outlook that have occurred since the 1979 Iranian revolution. The clear implication of these supply estimates is to project future world oil prices at a sharply higher rate.

The term "world oil price" refers to the refiners' acquisition cost of imported crude oil delivered to the United States with import fees excluded. Import fees on crude oil were suspended on April 1, 1979. A \$4.62 per barrel fee was imposed as of March 15, 1980, and only gasoline prices were affected. The projections on crude oil prices, therefore, do not include the fee, but its impact is incorporated in the gasoline price projections. However, the fee is currently in litigation. An injunction has been issued preventing the fee from being extended to gasoline prices and the final outcome is uncertain as of this writing.

Table 3.2 provides quarterly historical and projected refiners' acquisition costs of imported crude oil and the composite costs of imported and domestic crude oil. Domestic crude oil prices are projected to increase under the announced schedule for phased decontrol. Phased decontrol was discussed in the August 1979 EIA Analysis Report, *Projections of U.S. Petroleum Supply/Demand by Quarters Through 1980*, AR/IA/79-37, as well as in the October 1979 and February 1980 editions of the *Short-Term Energy Outlook*. These documents should be consulted for details on the phased deregulation of crude oil.

### Projections of Petroleum Product Prices

Projections of product prices are based on changes in crude oil costs (both domestic and



imported) and refiners' and marketers' margins. The price projections (expressed in current dollars), shown in Table 3.3, are based on alternative assumptions regarding world oil prices, as discussed above. The projections assume a dollar-for-dollar transmittal of crude oil cost increases as well as increases in refiners' and marketers' markups. Markups of product prices in these projections are assumed to range from no increase in the low-price case to increases with general inflation (as measured by the GNP implicit price deflator) in the midprice case and to increases 1.5 times that of general inflation in the high price case. (See Table 3.2.) Increases in margins are measured from a base month of September 1979 for gasoline and from August 1979 for all other products. Two exceptions to these general cases follow:

- Refiners' gasoline markups are determined by their allowable nonproduct costs, which in turn are determined by average nonproduct costs for all refined products and by gasoline yields. Price regulations allow refiners to pass a more than volumetrically proportionate amount of their nonproduct cost through to gasoline prices, depending upon yields. These price increases can exceed the general rate of inflation.
- Retailers' price markups in the middle and high cases on gasoline purchased from refiners and jobbers are assumed to escalate over the forecast period, which are consistent with new regulations governing gasoline retail margins. These regulations allowed a 15.4 cents per gallon margin for retailers of gasoline through 1979 and a 16.1 cents per gallon margin through the first half of 1980. Under the regulations, future margin increases will be allowed with inflation.

In general, the methodology is consistent with the DOE regulations concerning petroleum product prices. Of the major refined petroleum products, only gasoline remains under mandatory price and allocation controls. Depending on market conditions, prices for the other petroleum products could exceed these projections. Higher prices of gasoline could result if the underlying costs are higher than have been assumed or if refiners utilize their available cost "banks." (See Table 3.3.)

The combinations of different world oil price assumptions and gross margin assumptions have a significant impact on product prices, as Table 3.3 indicates. Crude oil costs to refiners are projected

to increase between 26.7 and 50.4 cents per gallon over the forecast period. The remaining increases in gasoline prices are due to the expected increases in refiners' and retailers' margins and to the effects of the gasoline "tilt" regulations. In the middle and high cases, refiners are allowed to increase gasoline prices at the expense of their cost "banks" or unrecouped costs. The banks, which have increased significantly since the inception of the "tilt" regulations, are allowed to be totally depleted in the high price case and partially depleted in the midprice case.

Retail prices for No. 2 heating oil are projected to range from 112.7 to 146.1 cents per gallon by the fourth quarter of 1981. Favorable weather could reduce demand during the winter, resulting in decreasing margins for heating oil and price increases more closely aligned with the underlying increases in crude oil costs. The projections represent increases from 28.8 to 62.2 cents per gallon over the forecast period (1980-81), lower than the projected increases for gasoline because of the "tilt" regulations discussed above. However, they still reflect increased crude oil costs and refiners' and retailers' margins.

Average wholesale prices for No. 6 residual fuel oil are projected to range from \$21.98 per barrel to \$43.66 per barrel for the fourth quarter of 1981. This wide range represents the market status of residual fuel oil as a "swing" product in consumption by electric utility generating plants and industrial natural gas consumers.

## SUPPLY AND DISPOSITION OF TOTAL ENERGY

### Energy Use

Total gross energy requirements in the United States are projected to decline from 78.8 quadrillion Btu in 1979 to 77.9 quadrillion Btu in 1980 and increase slightly to 78.1 quadrillion Btu in 1981 under the base-case projections. The decline in 1980 reflects the effects of slower economic growth with the real GNP essentially unchanged from the estimated 1979 level. In the same base-case forecast, real DPI is projected to decline by 0.5 percent in 1980 and to increase by 2 percent in 1981. The DPI is generally considered better than the GNP as an indicator of consumer purchases of specific energy products such as motor gasoline and home heating oil.

Estimates of total energy requirements for this report were aggregated from the projections of demand for specific products, as opposed to the alternative technique of projecting gross totals and sharing these downward among specific subgroups. It is instructive, however, to compare the aggregated totals of projected energy use with the GNP forecasts rather than the DPI because this comparison has conventionally been made by other organizations. Table 3.4 provides a comparison of annual data for the GNP and energy consumption, as projected for 1980 and 1981, along with actual data from 1973 through 1979.

In each year from 1973 to 1979, the energy/GNP ratio (thousand Btu per real dollar of GNP) has declined, implying that the trend is toward more efficient use of energy in the U.S. economy. The decline in that ratio for the 6-year period, 1973-79, is projected to continue in 1980 and 1981.

Table 3.5 presents the quarterly and annual projections of energy supply and use through 1981. This table is organized to aggregate the total supply of energy (in equivalent heat values) available to meet national requirements. Total domestic production plus net imports (net of exports) represent the total gross supply available in any period. The withdrawals from primary stocks (additions to supply for consumption) are also included to calculate a total primary supply. The disposition of this total is divided between nonutility and utility uses, with the utility portion further divided

among utility generation of electricity (at the thermal value of electricity 3,412 Btu per kilowatt hour [kWh]), utility conversion losses, and additions to utility fuel stocks. An intermediate series designated as "total net energy" represents the amount consumed either as fuel, raw materials for direct use, or utility-generated electricity. Electricity conversion losses and stock changes are added to account for disposition of total primary supply. The supply and disposition data are balanced in each designated period with any miscalculations in conversion or statistical differences shown as discrepancies.

The projected declines in energy use are mainly in petroleum products, especially motor gasoline and residual fuel oil used in generating electricity. The continuing shift to coal-fired generation reflects not only the preponderant role of coal in the additions to new utility capacity, but also the persistent replacement of oil by coal at existing stations.

## Energy Supply

The greater reliance on coal and the decline in oil use allows domestic energy production to increase during the forecast period, while imports (principally petroleum) decline. While total domestic energy production increases, a relatively small decline in domestic production of crude oil and natural gas occurs. Consequently, most of the decline in oil use is reflected in lower imports. In

**Table 3.4 Annual Changes in Real GNP and Energy Consumption**

Year	Real GNP		Energy Consumption (quadrillion Btu)			Ratio: Gross Energy/GNP	
	Billions 1972 Dollars	Annual Percent Change	Total Net <sup>a</sup>	Electric Utility Loss <sup>b</sup>	Total Gross	Annual Percent Change	Thousand Btu/ GNP 1972 dollars
<b>Actual</b>							
1973.....	1,235	5.5	60.7	13.9	74.6	4.2	60.4
1974.....	1,218	-1.4	58.7	14.1	72.8	-2.4	59.8
1975.....	1,202	-1.3	56.3	14.4	70.7	-2.9	58.8
1976.....	1,273	5.9	59.3	15.2	74.5	5.4	58.5
1977.....	1,340	5.3	60.4	16.1	76.5	2.7	57.1
1978.....	1,399	4.4	62.1	16.7	78.8	3.0	56.3
1979.....	1,432	2.4	61.7	17.1	78.8	0.0	55.0
<b>Projected</b>							
1980.....	1,433	-0.1	61.2	16.8	77.9	-1.0	54.4
1981.....	1,454	1.5	60.9	17.2	78.1	0.3	53.7

<sup>a</sup>Includes "errors or omissions" in historical data.

<sup>b</sup>Includes changes in utility fuel stocks.

Sources: GNP—Council of Economic Advisors, *Economic Indicators*, November 1979, prepared for the Joint Economic Committee. Energy data—U.S. Department of Energy, Energy Information Administration, *Monthly Energy Review*, December 1979.

1977, the record year for imports, total net imports were equivalent to 23.6 percent of total primary energy supply. In the projections for the base case, this percentage falls to about 19 percent of the total in 1980 and just below 19 percent in 1981.

Although this reduced reliance on imports is caused by a number of elements, one outstanding factor is the growing importance of electricity, which allows domestic coal and, to a lesser extent, nuclear power to account for a growing portion of the total energy. Domestic production of coal and nuclear power were equivalent to 23.3 percent of the total primary energy supply available for domestic use in 1978. In 1979, that percentage increased to 26 percent; it is projected to be 26.3 percent in 1980 and 27.8 percent in 1981.

### Sensitivity Analysis

Table 3.6 presents a summary of the incremental effects on all fuels and energy forms when the key driving variables change. The impacts of changes in the key driving variables are shown separately and then combined by the RMS procedure to approximate the changes in total energy use in two extreme scenarios, expressed as high and low demand.

Total gross energy demand (projected for 1980 and 1981 at 77.9 and 78.1 quadrillion Btu, respectively) varies from approximately 1 to 2 quadrillion Btu above or below the base case. The range in demand from 76.9 to 78.7 quadrillion Btu in 1980 and from 76.5 to 79.7 quadrillion Btu in 1981 indicates probable maximum and minimum effects for all variables.

### ELECTRICITY

The annual rates of increase in total electrical generation for 1980 and 1981 are predicted to be 3.2 percent and 2.8 percent respectively, considerably less than the 4.8-percent average rate experienced during the past decade. (See Figure 3.1 and Table 3.7.) This lowering of the growth rate reflects the steady increase in the cost of electricity because of increased fuel and capital costs, which result in part from environmental controls.

Coal-fired generation projected for 1980 is approximately 2.2 percent lower than that reported in the February 1980 projection. This projection is due to a revised total of the available coal-fired

capacity reported to DOE by the electric utility industry and in the expected commercial operation dates of new coal plants.

Gas-fired generation is projected to decline at a decreasing rate for 1980 and 1981. Oil-fired generation declines by 15.4 percent from 1979 to 1981. The decrease of gas-fired and oil-fired generation during the 2-year period is due to the opening of new coal-fired baseload plants in 1980 and the large increase in nuclear generation in 1981.

Generation of electricity by nuclear and coal-fired generating plants is estimated by using current and planned capacity additions and historical information on operating rates. (See Table 3.7.) Coal-fired plant capacity is expected to increase by 15,852 megawatts (MW) in 1980. An additional 11,802 MW of capacity is scheduled to be completed by 1981.

Coal-fired generation is projected by assuming that all of the new coal plants will operate to meet baseload demand. Coal plants shall begin producing electricity 2 months prior to their scheduled commercial operation dates and operate at a 30-percent capacity factor during this testing phase. Once commercial operation begins, a 50-percent capacity factor is assumed for the commercialized year with a 60-percent capacity factor thereafter. As a result of these assumptions, coal-fired generation is expected to increase by 4.7 percent in 1980 and by 7.3 percent in 1981.

Only four new nuclear units are scheduled to come into full commercial operation in 1980 under currently announced regulatory conditions (i.e., licensing resumption in spring 1980).<sup>4</sup> These four units, totaling nearly 4,300 MW of capacity, are essentially complete and probably would have been licensed by January 1980 except for the licensing suspension initiated last May. In view of the current situation, the earliest date that these four units could be licensed is May 1980. An additional five units totaling 5,000 MW could be licensed during the remainder of the year. A new capacity of 7,390 MW is scheduled for 1981.

Nuclear generation is projected to reach 273.4 billion kWh during 1980. The 1979 nuclear generation shows a 7.6-percent decline from 1978, reflecting regulatory shutdowns, extended refuelings, and major equipment replacement. The 1980 projection is 7.0 percent higher than the 1979 level, reflecting almost no change from the 1978 level.

<sup>4</sup> Salem 2, North Anna 2, Sequoyah 1, and Diablo Canyon 1.

**Table 3.5 Quarterly Supply and Disposition of Total Energy**  
(Quadrillion Btu)

Base Case	1978					1979				
	Quarter				Total	Quarter				Total
	1st	2nd	3rd	4th		1st	2nd	3rd	4th	
<b>Supply</b>										
Production <sup>a</sup>										
Petroleum <sup>b</sup>	5.02	5.21	5.26	5.25	20.74	5.07	5.10	5.15	5.17	20.48
Natural Gas	5.02	4.84	4.82	4.84	19.52	4.90	4.77	4.70	4.87	19.23
Coal	2.01	4.55	4.12	4.67	15.35	4.05	4.62	4.40	4.70	17.76
Nuclear	0.76	0.65	0.78	0.79	2.98	0.84	0.53	0.72	0.66	2.75
Hydroelectric <sup>c</sup>	0.75	0.83	0.71	0.64	2.93	0.75	0.83	0.66	0.68	2.92
Geothermal and Other <sup>d</sup>	0.02	0.01	0.02	0.02	0.07	0.02	0.02	0.02	0.03	0.09
Subtotal	13.58	16.09	15.71	16.21	61.59	15.63	15.87	15.64	16.10	63.24
Net Imports										
Crude Oil	3.08	3.00	3.33	3.39	12.80	3.17	3.17	3.29	3.28	12.91
Other Petroleum	1.11	0.90	0.95	0.99	3.95	1.07	0.79	0.78	0.91	3.55
Natural Gas (Dry)	0.25	0.22	0.20	0.25	0.91	0.26	0.24	0.23	0.28	1.01
Liquefied Natural Gas	-0.01	0.00	0.01	0.03	0.03	0.04	0.06	0.06	0.03	0.19
Coal and Coke	-0.03	-0.27	-0.23	-0.37	-0.89	-0.27	-0.43	-0.44	-0.52	-1.67
Electricity	0.01	0.01	0.01	0.01	0.06	0.01	0.01	0.01	0.01	0.06
Subtotal	4.42	3.86	4.27	4.31	16.85	4.28	3.84	3.94	4.00	16.07
Primary Stocks										
Net Withdrawals	2.25	-0.75	-1.36	0.22	0.36	2.12	-1.04	-1.56	-0.07	-0.54
<b>Total Primary Supply</b>	<b>20.25</b>	<b>19.20</b>	<b>18.62</b>	<b>20.74</b>	<b>78.80</b>	<b>22.04</b>	<b>18.68</b>	<b>18.02</b>	<b>20.03</b>	<b>78.76</b>
<b>Disposition</b>										
Nonutility Uses										
Petroleum	8.85	8.19	8.21	8.84	34.09	9.16	8.05	8.00	8.53	33.74
Natural Gas <sup>e</sup>	5.89	3.43	2.91	4.55	16.79	5.76	3.39	2.81	4.39	16.34
Coal	0.38	1.12	0.93	1.21	3.64	0.87	1.01	0.95	1.05	3.88
Nonutility Electricity <sup>f</sup>	0.02	0.02	0.02	0.02	0.09	0.02	0.02	0.02	0.02	0.09
Subtotal	15.14	12.76	12.07	14.63	54.60	15.81	12.47	11.77	13.99	54.04
Electricity by Source										
Petroleum	0.39	0.26	0.30	0.30	1.25	0.32	0.23	0.25	0.26	1.06
Natural Gas	0.22	0.26	0.32	0.23	1.04	0.23	0.28	0.34	0.27	1.12
Coal	0.76	0.79	0.92	0.86	3.33	0.90	0.88	0.96	0.93	3.67
Nuclear	0.24	0.21	0.25	0.25	0.94	0.27	0.17	0.23	0.21	0.87
Hydroelectric	0.25	0.27	0.23	0.21	0.96	0.25	0.27	0.21	0.22	0.95
Geothermal and Other	0.00	0.00	0.00	0.00	0.01	0.00	0.00	0.00	0.00	0.01
Subtotal	1.86	1.79	2.03	1.86	7.53	1.98	1.82	2.01	1.89	7.70
<b>Total Net Energy</b>	<b>17.00</b>	<b>14.55</b>	<b>14.10</b>	<b>16.48</b>	<b>62.13</b>	<b>17.79</b>	<b>14.30</b>	<b>13.78</b>	<b>15.88</b>	<b>61.74</b>
Electric Utility Adjustments										
Conversion Loss and Plant Use	3.96	3.72	4.28	3.89	15.85	4.23	3.82	4.27	3.98	16.31
Addition to Fuel Stocks	-1.29	0.77	0.10	0.15	-0.26	-0.25	0.44	0.07	0.42	0.68
Subtotal	2.67	4.49	4.38	4.05	15.59	3.99	4.26	4.34	4.41	16.99
Discrepancy	0.58	0.17	0.13	0.21	1.09	0.26	0.12	-0.09	-0.25	0.03
<b>Total Disposition</b>	<b>20.25</b>	<b>19.20</b>	<b>18.62</b>	<b>20.74</b>	<b>78.80</b>	<b>22.04</b>	<b>18.68</b>	<b>18.02</b>	<b>20.03</b>	<b>78.76</b>

<sup>a</sup>Includes crude oil and lease condensate, natural gas liquids, hydrogen, input to oil refineries.

<sup>b</sup>Dry natural gas.

<sup>c</sup>Includes utility and industrial production.

<sup>d</sup>Includes wood, waste, and other vegetal fuels used to generate electricity.

<sup>e</sup>Includes natural gas used as refinery fuel.

<sup>f</sup>This category currently contains only nonutility hydroelectric power.

Note: Historical data in this table may differ from comparable data in Volume 2 due to rounding error in cumulating from monthly data or to alternative methods of handling data on stocks, converting to Btu, or other modes of computation.

1980					1981				
Quarter					Quarter				
1st	2nd	3rd	4th	Total	1st	2nd	3rd	4th	Total
5.15	5.14	5.13	5.11	20.52	5.00	5.03	5.03	5.02	20.08
4.92	4.72	4.69	4.72	19.04	4.77	4.70	4.58	4.77	18.82
3.98	4.38	4.29	4.90	17.55	4.35	3.40	5.04	5.50	18.29
0.71	0.67	0.78	0.79	2.94	0.83	0.78	0.89	0.89	3.40
0.78	0.81	0.71	0.68	2.99	0.78	0.81	0.71	0.68	2.99
0.02	0.02	0.02	0.02	0.09	0.02	0.02	0.02	0.03	0.09
15.55	15.74	15.63	16.22	63.14	15.76	14.74	16.28	16.89	63.67
3.19	2.74	3.08	2.99	12.01	2.67	2.91	3.31	2.98	11.87
0.93	0.61	0.71	0.70	2.94	0.81	0.60	0.73	0.69	2.84
0.35	0.34	0.33	0.35	1.38	0.37	0.34	0.34	0.36	1.41
0.05	0.07	0.07	0.07	0.27	0.08	0.08	0.08	0.08	0.33
-0.31	-0.54	-0.47	-0.49	-1.81	-0.34	-0.46	-0.51	-0.53	-1.83
0.01	0.01	0.01	0.01	0.06	0.01	0.01	0.01	0.01	0.06
4.22	3.24	3.74	3.64	14.84	3.60	3.49	3.98	3.61	14.69
1.16	-0.44	-1.32	0.56	-0.04	1.47	-0.73	-1.57	0.61	-0.22
20.94	18.54	18.04	20.42	77.94	20.84	17.50	18.69	21.11	78.13
8.40	7.72	7.65	8.06	31.82	8.20	7.73	7.75	8.16	31.84
5.70	3.79	2.96	4.91	17.36	5.51	3.68	2.83	5.02	17.04
0.88	1.04	0.88	1.22	4.02	0.90	0.95	0.88	1.11	3.84
0.02	0.02	0.02	0.02	0.09	0.02	0.02	0.02	0.02	0.09
15.01	12.57	11.51	14.21	53.30	14.63	12.38	11.48	14.32	52.81
0.29	0.22	0.28	0.25	1.04	0.26	0.19	0.23	0.20	0.88
0.23	0.28	0.36	0.24	1.11	0.22	0.27	0.36	0.23	1.07
0.93	0.92	1.02	0.97	3.84	0.99	0.98	1.10	1.05	4.12
0.22	0.21	0.25	0.25	0.93	0.26	0.25	0.28	0.28	1.08
0.25	0.27	0.23	0.22	0.98	0.25	0.27	0.23	0.22	0.98
0.00	0.00	0.00	0.00	0.01	0.00	0.00	0.00	0.00	0.01
1.93	1.90	2.15	1.94	7.92	1.99	1.95	2.21	2.00	8.14
16.94	14.46	13.65	16.15	61.21	16.62	14.33	13.68	16.31	60.95
4.09	4.00	4.54	4.10	16.73	4.20	4.11	4.65	4.20	17.17
-0.11	0.12	-0.15	0.21	0.07	0.01	-0.88	0.28	0.55	-0.04
3.98	4.12	4.39	4.31	16.80	4.21	3.23	4.93	4.76	17.12
0.01	-0.04	0.00	-0.04	-0.07	0.01	-0.06	0.07	0.04	0.06
20.94	18.54	18.04	20.42	77.94	20.84	17.50	18.69	21.11	78.13

**Table 3.6 Total Energy Demand: Base Case and Scenario Differentials**  
(Quadrillion Btu)

Scenario Cases	1980					1981				
	Quarter				Total	Quarter				Total
	1st	2nd	3rd	4th		1st	2nd	3rd	4th	
Gross Energy Consumption										
Base Case .....	20.94	18.54	18.04	20.42	77.94	20.84	17.50	18.69	21.11	78.13
Price Sensitivity										
High Price .....	-0.08	-0.21	-0.23	-0.30	-0.82	-0.30	-0.28	-0.28	-0.39	-1.24
Low Price .....	0.09	0.12	0.12	0.23	0.56	0.28	0.25	0.32	0.44	1.29
Weather Sensitivity										
Favorable Weather .....	-0.06	-0.05	-0.11	-0.10	-0.32	-0.10	-0.04	-0.08	-0.08	-0.30
Adverse Weather .....	0.07	0.00	0.06	0.06	0.19	0.10	0.00	0.06	0.06	0.22
Economic Sensitivity										
High Economics .....	0.03	0.07	0.09	0.13	0.31	0.16	0.17	0.21	0.24	0.78
Low Economics .....	-0.03	-0.12	-0.14	-0.17	-0.46	-0.17	-0.21	-0.27	-0.26	-0.51
Motor Gasoline Price										
Elasticity Sensitivity										
High Elasticity .....	-0.03	-0.10	-0.12	-0.12	-0.37	-0.10	-0.14	-0.14	-0.15	-0.53
Low Elasticity .....	0.03	0.05	0.07	0.08	0.23	0.11	0.11	0.10	0.12	0.44
High Demand .....	0.12	0.15	0.18	0.28	0.71	0.36	0.32	0.40	0.52	1.59
Low Demand .....	-0.11	-0.27	-0.31	-0.38	-1.06	-0.37	-0.38	-0.42	-0.50	-1.66

Note: See Tables 3.2, 3.3, and 3.4 for assumed changes in key variables for price, weather, and economic sensitivities.

**Table 3.7 Quarterly Supply and Disposition of Electricity**  
(Billion Kilowatt-Hours)

Base Case	1978					1979				
	Quarter				Total	Quarter				Total
	1st	2nd	3rd	4th		1st	2nd	3rd	4th	
Generation										
Coal .....	222.20	230.79	270.08	252.67	975.74	264.94	257.43	281.46	271.15	1,074.98
Petroleum .....	114.46	75.47	88.06	87.10	365.09	93.82	66.44	74.38	68.88	303.52
Natural Gas .....	64.95	77.03	95.03	68.37	305.38	68.86	81.00	101.05	78.61	329.52
Nuclear .....	70.11	60.18	72.79	73.31	276.40	78.04	49.51	66.83	61.02	255.40
Hydroelectric .....	71.91	79.18	67.82	61.51	280.42	72.25	79.32	63.00	65.27	279.83
Geothermal and Other .....	0.93	0.62	0.89	0.88	3.32	0.99	1.04	1.12	1.23	4.39
Total Production .....	544.53	523.29	594.67	543.84	2,206.33	578.90	534.74	587.85	546.16	2,247.64
Total Net Imports .....	4.93	4.99	5.04	5.04	20.00	4.93	4.99	5.04	5.04	20.00
T & D Loss* .....	43.62	65.15	58.42	55.55	222.74	47.38	57.04	52.66	50.47	207.54
Total Disposition (sales) .....	505.84	463.13	541.29	493.33	2,003.58	536.45	482.69	540.23	500.73	2,060.10

\*T & D Loss = Transmission and distribution losses and other adjustments; for forecasted period, T & D Loss is assumed to be 9 percent of total production.

Note: The following table describes the oil- and gas-fired generation, and the nuclear generation of the low nuclear case.

Petroleum .....	85.02	63.44	84.53	77.80	310.79	80.48	60.88	77.99	69.56	288.92
Natural Gas .....	67.90	82.73	104.60	71.56	326.79	67.48	82.33	104.60	70.03	324.44
Nuclear .....	65.62	62.09	70.82	68.33	266.86	70.28	62.70	71.45	69.33	273.66
Total Production .....	566.90	555.73	628.78	568.92	2,320.33	582.70	571.22	646.31	584.78	2,385.02

Nuclear generation is projected to increase by over 15 percent in 1981.

### Sensitivity Analysis

It is assumed that changes in electricity generation because of alternative weather and prices of energy projects will be reflected only in the utility use of petroleum and natural gas. Nuclear, geothermal, and coal-fired production are constant across all cases because these facilities are used primarily for base load generation. Table 3.8 presents the differences in electricity demand between the base case and each sensitivity case. Figure 3.1 shows total generation, 1978-81, and the high- and low-demand cases for the forecast period.

In the low price case, the 1980 demand increase is accompanied by an increase in oil-fired production and a reduction in gas-fired production. This shift is the result of oil being economically more attractive than gas. However, the high price case shows that the opposite occurs: oil-fired production is lower, but gas-fired production is higher than in the base case.

Adverse weather increases the 1980 total gener-

ation by 22.6 billion kWh and increases the oil-fired and gas-fired production by 6.9 and 0.4 percent, respectively, over the base case. Favorable weather conditions reduce the 1980 total generation by 22.4 billion kWh and decreases the oil-fired and gas-fired production by 6.6 and 0.7 percent, respectively.

The low nuclear case, shown in the note on Table 3.7, assumes nuclear generation to be much lower than the base case because of delays in the 1980 and 1981 new plant openings and startup problems. The total demand for electricity was kept the same in both the base case and the low nuclear case. As a result, oil-fired and gas-fired production increased in 1980 and 1981 to account for the loss of nuclear generation.

### Supply of Resources

Table 3.9 summarizes the energy resources, consumed quarterly, to produce electricity from 1978 to 1981. The total of fossil fuels consumed by electric utilities is projected to increase by 4.7 percent over the 2 - year forecast period. Increased coal use exceeds the total increase because use of oil and natural gas is expected to decline over the forecast period.

1980					1981				
Quarter					Quarter				
1st	2nd	3rd	4th	Total	1st	2nd	3rd	4th	Total
272.64	268.60	299.40	284.50	1,125.14	288.70	286.40	322.80	309.20	1,207.10
85.02	63.34	82.70	73.85	304.91	75.66	54.95	67.23	59.07	256.91
67.90	82.73	104.60	70.93	326.16	65.21	78.19	104.17	67.27	314.85
65.62	62.19	72.65	72.91	273.37	77.38	72.76	82.64	82.48	315.26
74.72	77.86	68.32	65.61	286.51	74.72	77.86	68.32	65.61	286.51
1.00	1.01	1.11	1.12	4.24	1.03	1.05	1.15	1.16	4.39
566.90	555.73	628.78	568.92	2,320.33	582.70	571.22	646.31	584.78	2,385.02
4.21	4.31	4.31	4.31	17.15	4.21	4.31	4.31	4.31	17.15
51.02	50.02	56.59	51.20	208.83	52.44	51.41	58.17	52.63	214.65
520.09	510.02	576.50	522.03	2,128.65	534.47	524.12	592.46	536.47	2,187.51

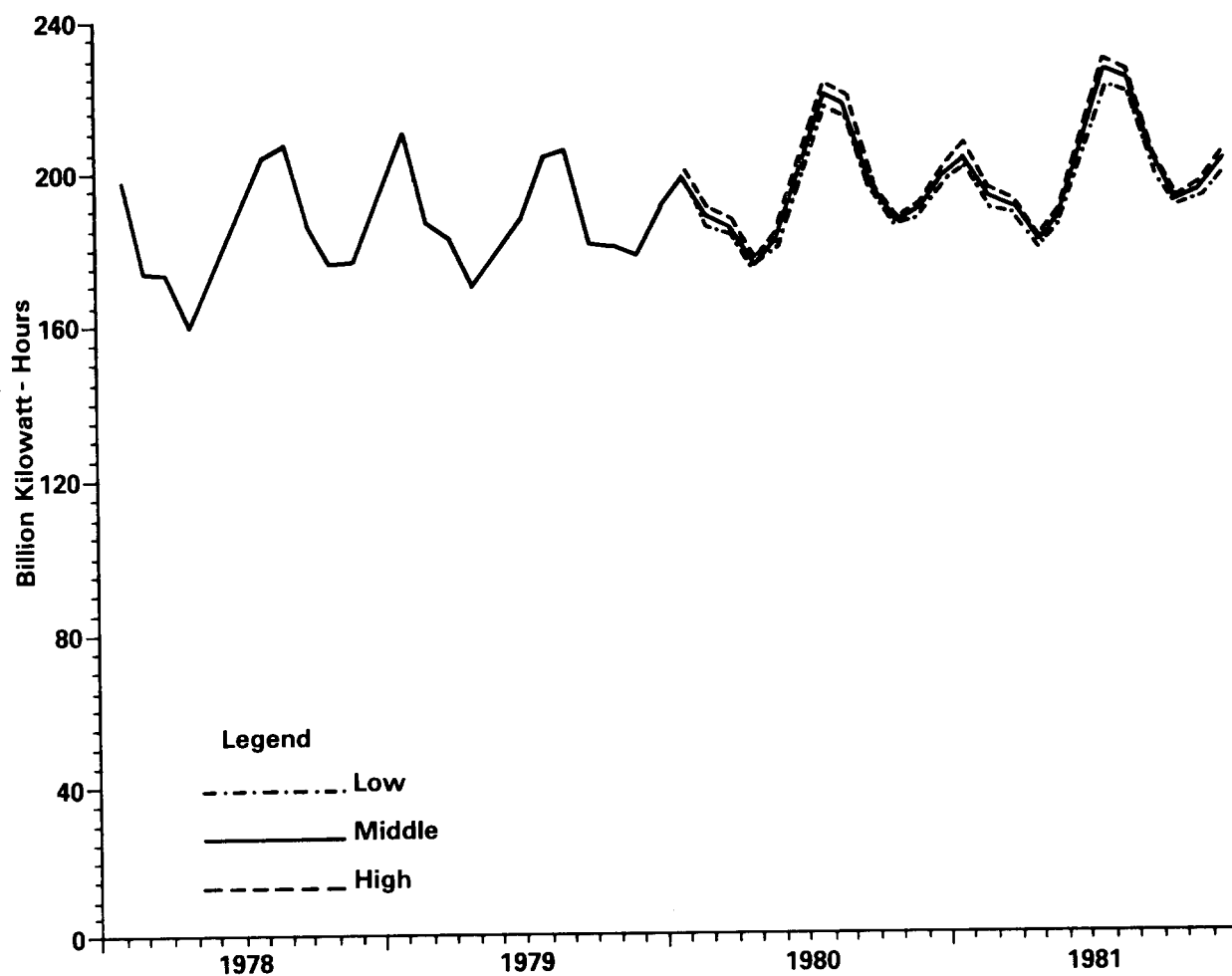

**Figure 3.1 Domestic Utility Generation of Electricity**

**Table 3.8 Electricity Demand, Base Case, and Scenario Differentials (Billion Kilowatt-Hours)**

Scenario Cases	1980					1981				
	Quarter				Total	Quarter				Total
	1st	2nd	3rd	4th		1st	2nd	3rd	4th	
Demand in 50 States Base Case .....	566.90	555.73	628.78	568.92	2,320.33	582.70	571.22	646.31	584.78	2,385.02
Price Sensitivity										
High Price .....	-1.90	-1.93	-2.18	-1.92	-7.93	-2.40	-2.32	-2.71	-2.49	-9.92
Low Price .....	1.70	1.57	1.82	1.58	6.67	2.30	2.18	2.49	2.21	9.18
Weather Sensitivity										
Favorable Weather .....	-6.50	-3.23	-8.18	-4.51	-22.42	-6.60	-3.52	-8.51	-4.59	-23.22
Adverse Weather .....	6.48	3.23	8.26	4.61	22.58	6.71	3.32	8.49	4.72	23.24
Economic Sensitivity										
High Economics .....	0	0	0	0	0	0	0	0	0	0
Low Economics .....	0	0	0	0	0	0	0	0	0	0
High Demand .....	6.70	3.60	8.45	4.87	23.54	7.09	3.98	8.84	5.22	24.99
Low Demand .....	-6.77	-3.76	-8.47	-4.90	-23.78	-7.03	-4.21	-8.93	-5.22	-25.25

Note: See Tables 3 and 4 for assumed changes in key variables for price, weather, and economic sensitivities.



## **CRUDE OIL AND PETROLEUM PRODUCTS**

The preoccupation with oil shortages during the first half of 1979 shifted later in that year to two concerns: (1) the economic and financial consequences of rising petroleum costs and (2) the need to build crude oil and product stocks because of continued uncertainty of supply. The leveling of demand in response to higher prices and the maintenance of high production levels in major oil exporting countries led to a rapid reversal in the general supply situation. In early 1980, stocks of all fuels were at high or adequate levels and world crude oil production was still meeting current needs. Higher prices and low U.S. economic growth projected for 1980 and 1981 are expected to reduce demand and further reduce import levels.

### **Domestic Crude Oil Production**

Total production of domestic crude oil is projected at 8.55 million barrels per day for 1980 and 8.38 million barrels per day in 1981 with Alaskan North Slope production at 1.5 million barrels per day in both years. The decline rate estimated for U.S. production in the sub-Arctic areas between 1979 and 1981 is 2.5 percent yearly, or a monthly decline of about 15,300 barrels per day. Table 3.10 presents historical and projected production data by quarters, from 1978 to 1981.

The continuing decline indicated in sub-Arctic production is assumed to proceed uniformly, although unexpected reductions in production often occur in the winter months. Other meteorological factors can affect production; for example, hurricanes caused lower production in July and September 1979.

North Slope crude oil production is projected to be maintained at 1.5 million barrels per day. This projection reflects higher flow rates through the Alaskan pipeline, resulting from the addition of a detergent to the crude oil to reduce resistance and the installation of a new pumping capacity.

Total production of domestic liquid fuels (including processing gains of 460,000 barrels per day) is forecast at 10.7 million barrels per day for 1980 and 10.5 million barrels per day for 1981. Any decrease in the projected level of production will result in an increase in the projected level of imports. If any curtailed production in anticipation

of higher net returns occurred (through both a gradual decontrol of crude oil prices and a lower windfall profits tax than had been proposed), additional production could result. It is also anticipated that decontrol will bring some uneconomic oil fields back into commercial status and make increased drilling profitable in areas with small concentrations of oil.

### **Total Petroleum Product Demand**

The base case consumption of petroleum products is projected to decline from 18.4 million barrels per day in 1979 to 17.6 million barrels per day in 1980 and to 17.4 million barrels per day in 1981. (See Table 3.10.) The projected 1980 demand will be the lowest level of demand since 1976. This demand is less than 2 percent higher than the demand in 1973, which was the last year of low prices. Demand in 1981 is expected to be 17.4 million barrels per day or a decrease of 1.1 percent from the estimated level in 1980.

The general demand trend is evident in the consumption of each of the major petroleum products. It is apparent that all sectors of the economy (industry, public utilities, and private consumers) are using petroleum products more sparingly and finding substitute sources of energy. Figure 3.2 indicates the decline in demand since 1978 and the likely projection of this trend through the fourth quarter of 1981.

The base-case demand projections assume mid-level estimates of weather, energy prices, and economic activity. Sensitivity analyses for variations from each of these base-case assumptions were performed on the demand for each major petroleum product. Though the sensitivity results for each of the key variables have been calculated separately, the variations above or below base-case demands have been aggregated to provide the relatively wide range shown in Figure 3.2. The components of that total are shown separately in Table 3.11.

### **Price Impacts**

The impact of alternative product prices, as shown above in Table 3.3, was evaluated separately for the major petroleum products in comparison with the base-case demand forecasts. Table 3.11 presents the petroleum product demand forecasts with three sets of price projections. The high-price assumptions reduce total demand projections by

about 380,000 barrels per day (relative to the base case) in 1980 and by 540,000 barrels per day in 1981; the lower prices increase total petroleum demand by 300,000 barrels per day in 1980 and 630,000 barrels per day in 1981. The demand response to changes in price, indicated for total petroleum, reflect the price elasticities of demand for individual major petroleum products. These elasticities are generally calculated from measured responses in historical data, but because consumer behavior changes in response to factors other than price, it is not obvious that the historical experience will be applicable for the future. In the case of motor gasoline, alternate assumptions about its price elasticity were made because this may be one area in which future consumer attitudes are changing, making the historical calculations less appropriate.

## Economic Impacts

For economic sensitivity analysis, variations were calculated from the base-case economic trend, which increases with the length of the forecast period. (See Table 3.2.) Table 3.11 shows the effects on petroleum demand with this range in the economic series. The variations in petroleum demand increase from about 80,000 barrels per day in the first quarter of 1980 to 480,000 barrels per day in the fourth quarter of 1981 above the base-case level with higher economic growth. Lower economic growth would reduce the projected petroleum demand by about 190,000 barrels per day in 1980 and 410,000 barrels per day in 1981. This widening range reflects the increasing projected estimated error of the macroeconomic forecasts, as described earlier in this chapter.

**Table 3.9 Quarterly Energy Resources to Produce Electricity  
(Quadrillion Btu)**

Base Case	1978					1979				
	Quarter				Total	Quarter				Total
	1st	2nd	3rd	4th		1st	2nd	3rd	4th	
<b>Supply of Resources</b>										
<b>Fuel Shipments</b>										
Petroleum										
Residual Fuel Oil .....	0.95	0.79	0.84	0.78	3.35	0.85	0.68	0.75	0.68	2.96
Distillate Fuel Oil .....	0.20	0.08	0.09	0.06	0.42	0.06	0.03	0.02	0.02	0.13
Other <sup>a</sup> .....	0.01	0	0	0	0.02	0	0	0	0	0.01
Subtotal .....	1.15	0.87	0.93	0.84	3.79	0.91	0.71	0.78	0.71	3.11
Natural Gas .....	0.69	0.82	1.02	0.73	3.26	0.73	0.88	1.11	0.85	3.56
Coal .....	1.18	3.08	2.91	2.92	10.10	2.64	3.05	3.03	3.28	11.99
<b>Total Fuels Shipped .....</b>	<b>3.02</b>	<b>4.78</b>	<b>4.87</b>	<b>4.49</b>	<b>17.14</b>	<b>4.28</b>	<b>4.64</b>	<b>4.91</b>	<b>4.83</b>	<b>18.67</b>
<b>Withdrawals From Utility Stocks</b>										
Petroleum .....	0.09	-0.05	-0.01	0.12	0.16	0.04	-0.06	-0.01	0.02	-0.01
Coal .....	1.20	-0.72	-0.09	-0.28	0.11	0.21	-0.38	-0.06	-0.44	-0.67
<b>Total Fossil Fuel Consumed<sup>b</sup> .....</b>	<b>4.30</b>	<b>4.01</b>	<b>4.77</b>	<b>4.33</b>	<b>17.41</b>	<b>4.52</b>	<b>4.20</b>	<b>4.84</b>	<b>4.41</b>	<b>17.98</b>
<b>Other Resources</b>										
Nuclear .....	0.76	0.65	0.78	0.79	2.98	0.84	0.53	0.72	0.66	2.75
Hydroelectric .....	0.75	0.83	0.71	0.64	2.93	0.75	0.83	0.66	0.68	2.92
Geothermal and Other .....	0.02	0.01	0.02	0.02	0.07	0.02	0.02	0.02	0.03	0.09
<b>Total Resource Inputs .....</b>	<b>5.83</b>	<b>5.49</b>	<b>6.28</b>	<b>5.78</b>	<b>23.38</b>	<b>6.14</b>	<b>5.59</b>	<b>6.25</b>	<b>5.78</b>	<b>23.75</b>
<b>Less: Conversion Losses .....</b>	<b>3.96</b>	<b>3.72</b>	<b>4.28</b>	<b>3.89</b>	<b>15.85</b>	<b>4.23</b>	<b>3.82</b>	<b>4.27</b>	<b>3.98</b>	<b>16.31</b>
<b>Net Generation<sup>c</sup> .....</b>	<b>1.86</b>	<b>1.79</b>	<b>2.03</b>	<b>1.86</b>	<b>7.53</b>	<b>1.98</b>	<b>1.82</b>	<b>2.01</b>	<b>1.86</b>	<b>7.67</b>
<b>Discrepancy .....</b>	<b>0.01</b>	<b>-0.01</b>	<b>-0.03</b>	<b>0.03</b>	<b>0</b>	<b>-0.07</b>	<b>-0.06</b>	<b>-0.03</b>	<b>-0.07</b>	<b>-0.23</b>

<sup>a</sup>Crude oil used as fuel.

<sup>b</sup>Reported shipments plus net stock withdrawals.

<sup>c</sup>Excludes imports of electricity and nonutility power from all sources.

Note: Historical data in this table may differ from comparable data in Volume 2 due to rounding error in cumulating from monthly data or to alternative methods of handling data on such things as stocks or converting to British thermal units.

## Weather

Table 3.11 also includes the sensitivity results of three demand forecasts designed to analyze the effects of varying weather conditions on petroleum product demand. These variations in the weather assumptions were described earlier. Economic and price variables are given their base-case values for this calculation of weather effects.

Cold winters increase demand for petroleum products for space heating and electricity generation, but cold summers reduce demand because the utility requirements for peak power generation for air conditioners are reduced. In the first quarter of 1981, demand projections vary from a decrease of 190,000 barrels per day in mild weather to an increase of 190,000 barrels per day in severe weather. An unusually hot summer could result in

an additional demand of 160,000 barrels per day in the third quarter.

## Gasoline Consumption

The declining trend in motor gasoline use, evident in 1979, is projected to continue during the forecast period. (See Figure 3.3.) The quarterly and annual data presented in Table 3.12 project total motor gasoline consumption (leaded and unleaded) at 6.68 million barrels per day in 1980 and at 6.61 million barrels per day in 1981 in the base case. These projections are based on figures published in EIA's *Monthly Energy Review* (MER). This source publishes total motor gasoline "product supplied" which is calculated from amounts produced domestically, adding imports

1980					1981				
Quarter					Quarter				
1st	2nd	3rd	4th	Total	1st	2nd	3rd	4th	Total
0.80	0.69	0.84	0.68	3.02	0.69	0.58	0.68	0.53	2.48
0.11	0.10	0.13	0.10	0.43	0.10	0.09	0.12	0.08	0.40
0	0	0	0	0.01	0	0	0	0	0.01
0.92	0.79	0.97	0.78	3.46	0.79	0.68	0.80	0.62	2.89
0.72	0.88	1.12	0.76	3.48	0.70	0.83	1.11	0.72	3.36
2.76	2.84	2.93	3.22	11.75	3.07	2.05	3.60	3.82	12.53
4.41	4.51	5.02	4.76	18.69	4.56	3.56	5.51	5.15	18.78
0.04	-0.08	-0.05	0.04	-0.04	0.06	-0.06	-0.05	0.04	0.0
0.08	-0.04	0.19	-0.26	-0.03	-0.06	0.94	-0.23	-0.60	0.04
4.52	4.39	5.16	4.55	18.62	4.55	4.44	5.23	4.60	18.82
0.71	0.67	0.78	0.79	2.94	0.83	0.78	0.89	0.89	3.40
0.78	0.81	0.71	0.68	2.99	0.78	0.81	0.71	0.68	2.99
0.02	0.02	0.02	0.02	0.09	0.02	0.02	0.02	0.03	0.09
6.03	5.90	6.68	6.04	24.64	6.19	6.06	6.86	6.20	25.30
4.09	4.00	4.54	4.10	16.73	4.20	4.11	4.65	4.20	17.17
1.93	1.90	2.15	1.94	7.92	1.99	1.95	2.21	2.00	8.14
0	0	0	0	0	0	0	0	0	0

**Table 3.10 Quarterly Supply and Disposition of Petroleum**  
(Million Barrels per Day, Except Stocks)

Base Case	1978					1979				
	Quarter				Total	Quarter				Total
	1st	2nd	3rd	4th		1st	2nd	3rd	4th	
<b>Supply</b>										
Production										
Crude Oil	8.51	8.78	8.77	8.74	8.70	8.51	8.51	8.51	8.53	8.51
North Slope	0.86	1.11	1.17	1.21	1.09	1.20	1.20	1.31	1.42	1.28
Subarctic	7.66	7.66	7.60	7.53	7.61	7.32	7.31	7.20	7.10	7.23
Natural Gas Liquids	1.57	1.58	1.55	1.57	1.57	1.73	1.67	1.62	1.64	1.66
Other Domestic	0.05	0.05	0.06	0.05	0.05	0.03	0.04	0.06	0.06	0.05
Processing Gain	0.46	0.47	0.49	0.49	0.48	0.46	0.47	0.48	0.46	0.47
<b>Total Production</b>	<b>10.59</b>	<b>10.87</b>	<b>10.87</b>	<b>10.85</b>	<b>10.80</b>	<b>10.74</b>	<b>10.68</b>	<b>10.67</b>	<b>10.69</b>	<b>10.70</b>
Imports										
Crude Oil*	5.95	5.81	6.41	6.60	6.19	6.33	6.22	6.38	6.36	6.32
Refined Products	2.26	1.86	1.93	2.00	2.01	2.23	1.71	1.69	1.91	1.88
<b>Total Imports</b>	<b>8.20</b>	<b>7.66</b>	<b>8.35</b>	<b>8.60</b>	<b>8.21</b>	<b>8.56</b>	<b>7.93</b>	<b>8.07</b>	<b>8.28</b>	<b>8.21</b>
Exports										
Crude Oil	0.06	0.14	0.19	0.25	0.16	0.28	0.22	0.22	0.22	0.23
Refined Products	0.19	0.21	0.22	0.20	0.20	0.22	0.24	0.24	0.23	0.23
<b>Total Exports</b>	<b>0.25</b>	<b>0.35</b>	<b>0.40</b>	<b>0.45</b>	<b>0.36</b>	<b>0.49</b>	<b>0.47</b>	<b>0.46</b>	<b>0.45</b>	<b>0.47</b>
<b>Net Imports</b>	<b>7.96</b>	<b>7.31</b>	<b>7.94</b>	<b>8.16</b>	<b>7.84</b>	<b>8.06</b>	<b>7.47</b>	<b>7.61</b>	<b>7.83</b>	<b>7.74</b>
Primary Stock Levels* (million barrels)										
Opening	1,304.00	1,149.00	1,155.00	1,216.00	1,304.00	1,211.00	1,068.00	1,126.00	1,221.00	1,211.00
Closing	1,149.00	1,155.00	1,216.00	1,211.00	1,211.00	1,068.00	1,126.00	1,221.00	1,246.00	1,246.00
Net Withdrawals (MMBD)	1.72	-0.06	-0.66	0.06	0.26	1.58	-0.63	-1.04	-0.27	-0.10
<b>Total Primary Supply</b>	<b>20.27</b>	<b>18.12</b>	<b>18.15</b>	<b>19.06</b>	<b>18.90</b>	<b>20.38</b>	<b>17.51</b>	<b>17.25</b>	<b>18.25</b>	<b>18.34</b>
Disposition										
Motor Gasoline	6.94	7.61	7.62	7.47	7.41	7.12	7.15	7.02	6.83	7.03
Distillate Fuel Oil	4.46	3.02	2.66	3.61	3.43	4.30	2.90	2.66	3.36	3.30
Residual Fuel Oil	3.67	2.77	2.81	2.86	3.02	3.45	2.51	2.47	2.75	2.79
Other Products	5.01	4.68	5.00	5.25	4.99	5.43	5.00	5.28	5.39	5.28
<b>Total Products Supplied</b>	<b>20.07</b>	<b>18.09</b>	<b>18.08</b>	<b>19.18</b>	<b>18.85</b>	<b>20.31</b>	<b>17.57</b>	<b>17.43</b>	<b>18.33</b>	<b>18.40</b>
Discrepancy	0.20	0.04	0.06	-0.12	0.04	0.08	-0.06	-0.18	-0.07	-0.06
<b>Total Primary Disposition</b>	<b>20.27</b>	<b>18.12</b>	<b>18.15</b>	<b>19.06</b>	<b>18.90</b>	<b>20.38</b>	<b>17.51</b>	<b>17.25</b>	<b>18.25</b>	<b>18.34</b>

\*Excludes crude oil for the Strategic Petroleum Reserve (SPR).

MMBD = Million barrels per day.

Note: Historical data in this table may differ from comparable data in Volume 2 due to rounding error in cumulating from monthly data.

1980					1981				
Quarter				Total	Quarter				Total
1st	2nd	3rd	4th		1st	2nd	3rd	4th	
8.60	8.62	8.52	8.46	8.55	8.44	8.42	8.35	8.29	8.38
1.50	1.50	1.50	1.50	1.50	1.50	1.50	1.50	1.50	1.50
7.10	7.12	7.02	6.96	7.05	6.94	6.92	6.85	6.79	6.88
1.66	1.59	1.56	1.57	1.60	1.63	1.58	1.53	1.59	1.58
0.05	0.05	0.06	0.06	0.06	0.05	0.06	0.06	0.06	0.06
0.47	0.45	0.46	0.45	0.46	0.43	0.45	0.47	0.44	0.45
10.77	10.71	10.61	10.55	10.66	10.56	10.50	10.41	10.39	10.47
6.28	5.44	6.01	5.85	5.90	5.35	5.75	6.45	5.83	5.85
1.98	1.37	1.54	1.53	1.61	1.78	1.38	1.60	1.54	1.57
8.26	6.81	7.56	7.38	7.50	7.13	7.13	8.05	7.37	7.42
0.25	0.25	0.25	0.25	0.25	0.25	0.25	0.25	0.25	0.25
0.23	0.23	0.22	0.22	0.23	0.24	0.23	0.23	0.23	0.23
0.48	0.48	0.47	0.47	0.48	0.49	0.48	0.48	0.48	0.48
7.78	6.34	7.08	6.91	7.03	6.64	6.65	7.57	6.89	6.94
1,246.00	1,239.00	1,240.00	1,296.00	1,246.00	1,284.00	1,195.00	1,222.00	1,314.00	1,284.00
1,239.00	1,240.00	1,296.00	1,284.00	1,284.00	1,195.00	1,222.00	1,314.00	1,294.00	1,294.00
0.08	-0.01	-0.61	0.13	-0.10	0.99	-0.29	-1.01	0.22	-0.03
18.64	17.03	17.08	17.58	17.58	18.19	16.86	16.98	17.49	17.38
6.54	6.85	6.76	6.59	6.68	6.31	6.75	6.76	6.63	6.61
3.87	2.90	2.69	3.30	3.19	3.81	2.96	2.78	3.36	3.23
2.99	2.38	2.42	2.37	2.54	2.75	2.19	2.17	2.13	2.31
5.22	4.90	5.21	5.32	5.17	5.32	4.96	5.26	5.37	5.23
18.61	17.03	17.08	17.58	17.58	18.19	16.86	16.98	17.49	17.38
0.02	0	0	0	0.01	0	0	0	0	0
18.64	17.03	17.08	17.58	17.58	18.19	16.86	16.98	17.49	17.38

**Table 3.11 Petroleum Demand—Base Case and Scenario Differentials**  
(Million Barrels per Day)

Scenario Cases	1980					1981				
	Quarter				Total	Quarter				Total
	1st	2nd	3rd	4th		1st	2nd	3rd	4th	
Demand in 50 States										
Base Case .....	18.61	17.03	17.08	17.58	17.58	18.19	16.86	16.98	17.49	17.38
Price Sensitivity										
High Price .....	-0.28	-0.34	-0.37	-0.52	-0.38	-0.55	-0.48	-0.47	-0.67	-0.54
Low Price .....	0.24	0.26	0.26	0.44	0.30	0.52	0.50	0.64	0.84	0.63
Weather Sensitivity										
Favorable Weather .....	-0.19	-0.05	-0.16	-0.14	-0.14	-0.19	-0.03	-0.09	-0.13	-0.11
Adverse Weather .....	0.20	0.05	0.16	0.14	0.14	0.19	0.03	0.16	0.14	0.13
Economic Sensitivity										
High Economics .....	0.08	0.18	0.22	0.28	0.19	0.32	0.37	0.46	0.48	0.41
Low Economics .....	-0.08	-0.18	-0.22	-0.28	-0.19	-0.32	-0.37	-0.46	-0.48	-0.41
Motor Gasoline Price										
Elasticity Sensitivity										
High Elasticity .....	-0.08	-0.15	-0.18	-0.19	-0.15	-0.21	-0.24	-0.25	-0.26	-0.24
Low Elasticity .....	0.08	0.15	0.19	0.20	0.16	0.22	0.25	0.26	0.27	0.25
High Demand .....	0.33	0.35	0.42	0.58	0.41	0.68	0.67	0.85	1.01	0.80
Low Demand .....	-0.36	-0.42	-0.49	-0.64	-0.47	-0.70	-0.65	-0.71	-0.87	-0.73

Note: See Tables 3.2, 3.3, and 3.4 for assumed changes in key variables for price, weather, and economic sensitivities.

and withdrawals from primary stocks. The collection points for this series are at refineries and bulk terminals. The Federal Highway Administration (FHWA) collects a related series of data called total motor gasoline "sales" which is based on data from State gasoline sales tax. Current estimates indicate that the total product supplied data is about 320,000 barrels per day less than the total sales data FHWA publishes.

Rising gasoline prices, effects of economic slow-downs, and improvements in the fuel efficiency of the auto fleet combine to halt the historical growth in gasoline use. Figure 3.3 plots this trend in motor gasoline demand and shows the calculated variations from the base-case projections under different economic trends and price assumptions, as shown in Tables 3.2 and 3.3.

In the base case, the retail price of regular leaded motor gasoline is projected to increase from a 1979 average of 87.0 cents per gallon to 132.8 cents per gallon in 1980 and 162.8 cents per gallon in 1981. The high- and low-price variations shown in Table 3.3 increase over the forecast period and, by the fourth quarter of 1981, range from a low of 144.6 cents per gallon to a high of 183.6 cents per gallon.

These price ranges result in relatively small variations in demand during the forecast period.

(See Table 3.13.) Higher prices would result in a reduction in demand of about 30,000 barrels per day in the first quarter of 1980 and 140,000 barrels per day in the last quarter of 1981. Demand for motor gasoline is not perceptibly affected by the weather assumptions. The higher and lower economic trends would change demand by 80,000 barrels per day above or below the base-case demand in 1980 and 160,000 barrels per day in 1981. The combined effects of these changes in basic conditions (combined by the RMS procedure discussed previously) would be a variation of about 180,000 barrels per day above to 190,000 barrels per day below the projected base-case average for 1980 and 320,000 barrels above and below in 1981. This variation implies a potential range in 1980 demand between 6.49 and 6.86 million barrels per day and between 6.29 and 6.93 million barrels per day in 1981.

### Motor Gasoline Supply Capabilities

In addition to the general concern about crude oil supplies, particular concern in recent years focuses on the ability of domestic refiners to produce adequate volumes of leaded and unleaded grades of motor gasoline. This concern is derived from the increasing demand for unleaded gasoline,

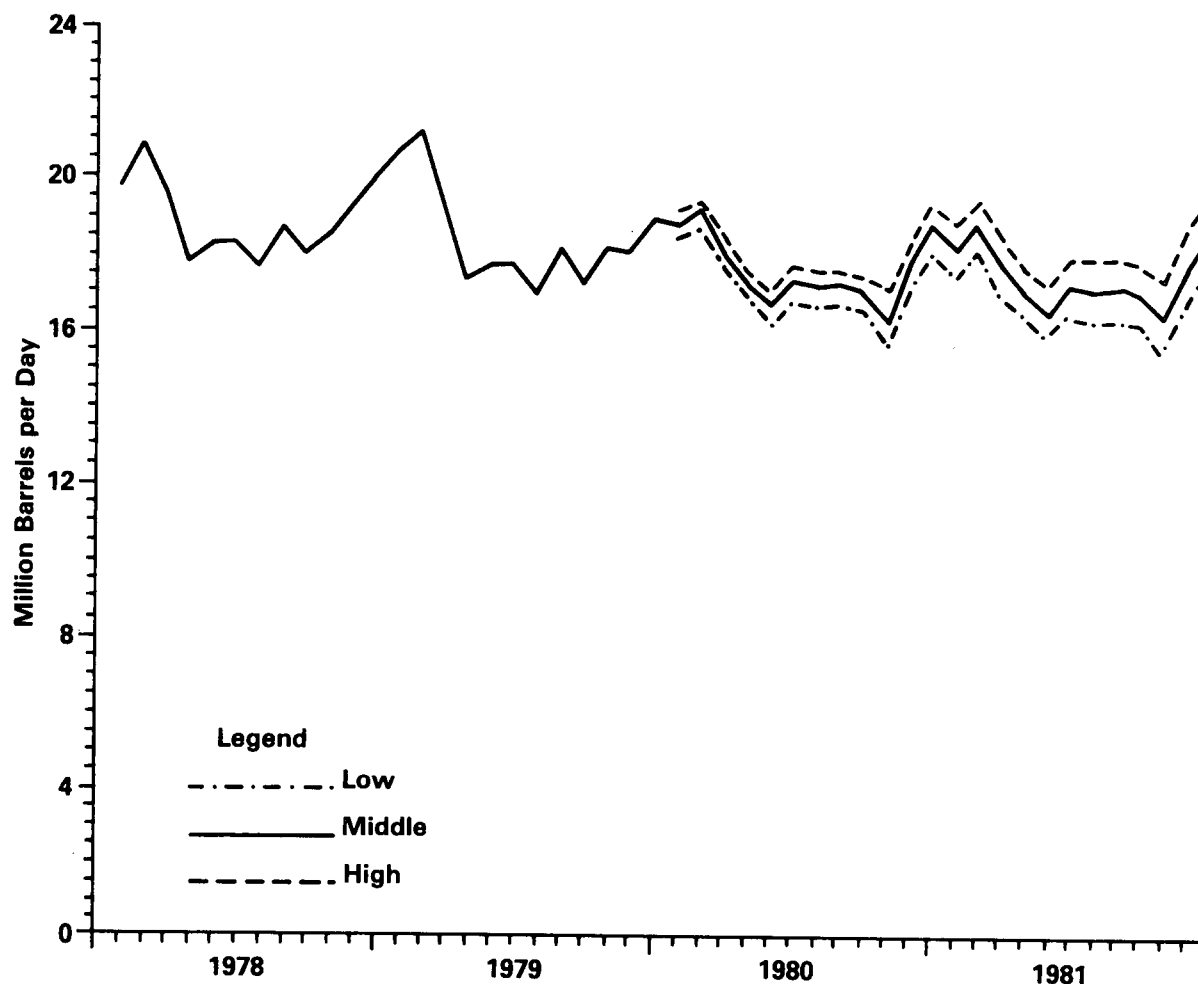

**Figure 3.2 Domestic Demand for Total Petroleum Products**

the slow growth of the refining capacity required to produce the higher octane gasoline blendstocks, and the environmental measures that have restricted refinery operation.

However, the gasoline supply outlook has improved considerably in recent months. The principal change in the outlook is due to decreased levels of gasoline consumption, with increasing gasoline prices and low economic growth. In addition, the Environmental Protection Agency's (EPA) lead phasedown program for 1980 has been delayed; the unleaded share of the market is growing more slowly than had been expected (because of low new car sales) and the leaded premium share of the market has been declining faster than had been expected. The result of these trends is that gasoline quality requirements are less stringent than had been expected a year ago; hence, U.S. refineries can produce more gasoline that meets

expected quality requirements than had been previously estimated.

The refining industry should have little difficulty in meeting total requirements in these ranges. In early 1981, over half of the projected total is unleaded fuel compared with 40 percent in 1979 and 34 percent in 1978. (See Table 3.12.) The capacity to supply motor gasoline of appropriate quality also appears to be adequate.

### **Distillate Fuel Oil Consumption**

Distillate fuel oil use is projected to decrease from 3.30 million barrels per day in 1979 to 3.18 million barrels per day in 1980 and to increase to 3.23 million barrels per day in 1981. (See Table 3.14.) Although consumption in 1979 was affected by colder than normal weather in the first quarter

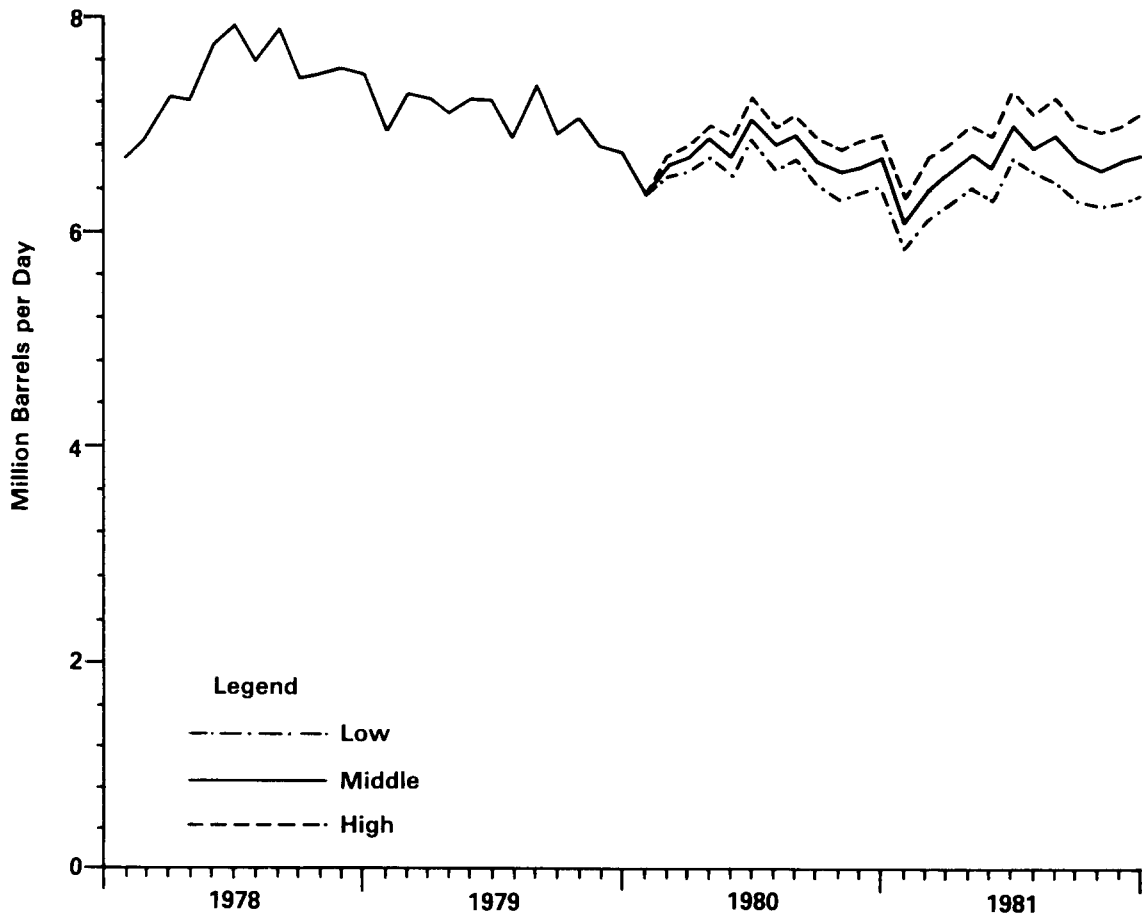

Figure 3.3 Domestic Demand for Motor Gasoline

Table 3.12 Quarterly Supply and Disposition of Motor Gasoline  
(Million Barrels per Day, Except Stocks)

Base Case	1978					1979				
	Quarter				Total	Quarter				Total
	1st	2nd	3rd	4th		1st	2nd	3rd	4th	
<b>Supply</b>										
Refinery Output.....	6.78	6.98	7.37	7.53	7.17	6.96	6.85	6.84	6.70	6.83
Imports.....	0.19	0.20	0.22	0.18	0.19	0.17	0.19	0.17	0.20	0.18
Exports.....	0	0	0	0	0	0	0	0	0	0
Net Imports.....	0.19	0.20	0.22	0.18	0.19	0.17	0.19	0.17	0.20	0.18
<b>Primary Stocks</b> (million barrels)										
Opening.....	257.6	259.6	219.4	216.5	257.6	238.0	239.2	229.3	229.6	238.0
Closing.....	259.6	219.4	216.5	238.0	238.0	239.2	229.3	229.6	236.7	236.7
Net Withdrawals (MMBD).....	-0.02	0.44	0.03	-0.23	0.05	-0.01	0.11	0.00	-0.08	0.00
Total Primary Supply.....	6.94	7.62	7.62	7.47	7.41	7.11	7.14	7.01	6.82	7.02
<b>Disposition</b>										
Leaded.....	4.71	5.13	4.93	4.79	4.89	4.43	4.38	4.16	3.96	4.23
Unleaded.....	2.23	2.48	2.69	2.68	2.52	2.69	2.77	2.86	2.87	2.80
Discrepancy.....	0.00	0.00	0.00	0.01	0.00	-0.01	-0.01	-0.02	-0.01	-0.01
Total Disposition.....	6.94	7.62	7.62	7.47	7.41	7.11	7.14	7.01	6.82	7.02

MMBD = Million barrels per day.

Note: Historical data in this table may differ from comparable data in Volume 2 due to rounding error in cumulating from monthly data.



of the year, the base-case projections for 1980 and 1981 assume normal weather. Significant price increases and low economic activity also contribute to the projected decline in 1980. The higher level of economic activity in 1981 causes the modest increase in distillate fuel oil use in 1981.

Distillate fuel oil demand, as shown in Figure 3.4 and Table 3.15, displays relatively small responses to higher or lower prices. In the first quarter of 1981, demand is reduced by about 10,000 barrels per day (from the base case of 3.85 million barrels per day) for the high price scenario. The demand for distillate fuel oil is not price sensitive during the spring and summer quarters. The largest sensitivity impact, as might be expected, is on winter demand for distillate fuel oil with changes in weather conditions. Adverse weather (5 percent colder than normal) is projected to increase distillate demand by 80,000 barrels per day, or about 2.1 percent in the first quarter of 1981. The decrease for 7-percent warmer weather is 50,000 and 80,000 barrels per day in the first quarters of 1980 and 1981, respectively. In the fourth quarter of 1980 and 1981, the indicated cold weather impact is an excess of 60,000 per day. The slight increase of 10,000 barrels per day for adverse weather in the spring and summer reflects increased use of distillate fuel oil to generate electricity that is used for air conditioning.

The impacts of higher or lower economic growth indicate variations in annual demands for distillate fuel oil of about 60,000 barrels per day in 1980 and 130,000 barrels per day in 1981. The total high- and low-demand figures, obtained by combining the impacts of variations in income, price, and weather by using the RMS procedure, are 70,000 barrels per day during 1980 and 150,000 and 140,000 barrels per day above and below the base case in 1981.

## Residual Fuel Oil

The nature and uses of residual fuel oil make it more susceptible than other petroleum products to direct competition by other fuels. Further, regulatory pressures under legislation favorable to competitive fuels, especially coal, have helped reduce the market for residual fuel oil.

Use of residual fuel oil has been down in all major markets—industrial, commercial heating, and utility. Total shipments to all users in 1979 were more than 7.6 percent lower than in 1978 when demand was increased by the coal strike. (See Figure 3.5 and Table 3.16.) However, the actual decline in use was much greater with the difference being accounted for by a sizeable change in the increases in consumers' stocks. Total

1980					1981				
Quarter					Quarter				
1st	2nd	3rd	4th	Total	1st	2nd	3rd	4th	Total
6.86	6.37	6.44	6.63	6.57	6.23	6.37	6.55	6.59	6.44
0.17	0.16	0.17	0.15	0.17	0.15	0.17	0.18	0.15	0.17
0	0	0	0	0	0	0	0	0	0
0.17	0.16	0.17	0.15	0.16	0.15	0.17	0.18	0.15	0.16
236.7	281.5	252.8	238.8	236.7	256.3	262.4	244.0	241.7	256.3
281.5	252.8	238.8	256.3	256.3	262.4	244.0	241.7	252.2	252.2
-0.49	0.32	0.15	-0.19	-0.05	-0.07	0.20	0.02	-0.11	0.01
6.54	6.85	6.76	6.59	6.68	6.31	6.75	6.76	6.63	6.61
3.66	3.73	3.58	3.38	3.58	3.15	3.25	3.14	2.98	3.13
2.88	3.12	3.18	3.21	3.10	3.16	3.50	3.62	3.65	3.48
0	0	0	0	0	0	0	0	0	0
6.54	6.85	6.76	6.59	6.68	6.31	6.75	6.76	6.63	6.61

**Table 3.13 Motor Gasoline Demand: Base Case and Scenario Differentials\***  
(Million Barrels per Day)

Scenario Cases	1980					1981				
	Quarter				Total	Quarter				Total
	1st	2nd	3rd	4th		1st	2nd	3rd	4th	
Demand in 50 States Base Case .....	6.54	6.85	6.76	6.59	6.68	6.31	6.75	6.76	6.63	6.61
Price Sensitivity										
High Price .....	-0.03	-0.09	-0.10	-0.10	-0.08	-0.12	-0.14	-0.15	-0.15	-0.14
Low Price .....	0	0.01	0.03	0.05	0.02	0.07	0.11	0.14	0.17	0.12
Weather Sensitivity										
Favorable Weather .....	0	0	0	0	0	0	0	0	0	0
Adverse Weather .....	0	0	0	0	0	0	0	0	0	0
Economic Sensitivity										
High Economics .....	0.03	0.07	0.09	0.11	0.08	0.12	0.14	0.18	0.18	0.16
Low Economics .....	-0.03	-0.07	-0.09	-0.11	-0.08	-0.12	-0.15	-0.18	-0.19	-0.16
Motor Gasoline Price Elasticity Sensitivity										
High Elasticity .....	-0.08	-0.15	-0.18	-0.19	-0.15	-0.20	-0.24	-0.21	-0.26	-0.24
Low Elasticity .....	0.08	0.15	0.19	0.20	0.16	0.22	0.25	0.26	0.27	0.25
High Demand .....	0.09	0.17	0.21	0.23	0.18	0.26	0.31	0.35	0.37	0.32
Low Demand .....	-0.09	-0.19	-0.22	-0.24	-0.19	-0.26	-0.32	-0.31	-0.36	-0.32

\*Historical data are from EIA *Monthly Petroleum Statements and/or Monthly Energy Reports*. Federal Highway Administration data are used in the gasoline demand model (see Analysis Section E).

Note: See Tables 3.2 and 3.3 for assumed changes in key variables for price, weather, and economic sensitivities.

shipments (primary supply) are projected to decline to 2.54 million barrels per day in 1980 and to 2.31 million barrels per day in 1981.

The results of the sensitivity analysis indicate that lower prices and adverse weather conditions could increase shipments significantly. (See Table 3.17.) Residual fuel oil prices in the base case are projected to increase from \$18.70 per barrel (annual average) in 1979 to \$26.54 per barrel in 1980 and \$31.05 per barrel in 1981. In the low price case, the average price is \$20.91 per barrel in 1980 and \$22.01 per barrel in 1981, and demand for residual fuel oil is projected to be 260,000 barrels per day higher in 1980 and 460,000 barrels per day higher in 1981, relative to the base case.

Cold winter weather and hot summer weather could increase residual fuel oil requirements by 90,000 to 100,000 barrels per day in 1980 and 1981 directly through effects on consumption and indirectly through higher demand for electricity.

Although variations in economic forecasts above and below the base case have relatively small effects on residual fuel oil requirements, the effects of prices, weather, and macroeconomic factors combined by the RMS procedure are calculated to reduce requirements by as much as

280,000 barrels per day in 1980 and 380,000 barrels per day in 1981 or raise them by 280,000 barrels per day in 1980 and 470,000 barrels per day in 1981. Because residual fuel oil is a major product import, variations from base-case requirements will generally raise or lower imports accordingly.

## Petroleum Imports

The petroleum import variations presented in Figure 3.6 and Table 3.18 indicate that the combined effects of sensitivities for alternative price, weather, and macroeconomic assumptions could lower the 1980 total by 390,000 barrels per day. Most of the total variation relates to the alternative price assumptions. The remaining difference is mainly attributable to economic variations.

These large variations suggest a high order of uncertainty in the projections of total net petroleum imports. A substantial variation in import projections occurs because oil imports are the marginal energy source for the United States. Imports compensate for the slack between high, but variable, levels of total petroleum demand and modest yearly fluctuations in domestic crude and

natural gas liquids production. The 1980 base-case estimate of 7.03 million barrels per day of total net imports (crude oil and petroleum products) excludes any allowance for additions to the Strategic Petroleum Reserve (SPR). The comparable 1977 net imports, excluding SPR, were 8.47 million barrels per day, 1.44 million barrels per day higher than the 1980 base-case projection. After adding the 0.35 million barrels per day, which is calculated from the high range of the sensitivity analyses, total imports would be only 7.38 million barrels per day or 1.09 million barrels per day below 1977 levels.

## BALANCE OF PAYMENTS COST OF PETROLEUM IMPORTS

The National Income and Product Accounts, kept by the Department of Commerce, are based on a United States consisting of the 50 States and the District of Columbia. The forecasts presented here are for the same areas. However, for the calculation of balance of payments data, the "United States" includes the Commonwealth of Puerto Rico, the Virgin Islands, Guam, and, at least conceptually, all other territories under the U.S. flag. The Bureau of Economic Analysis (BEA) of the Department of Commerce prepares the estimates of the cost of imports on the balance of payments basis.

The lower three lines on Table 3.19 (through the fourth quarter of 1979) are based on BEA data. The EIA made the projections on the BEA basis through 1981, by adding incremental amounts for offshore areas to the 50-State forecasts, as indicated. The average free alongside ship (f.a.s.) cost for all imports of crude oil and refined products into the 50 States, Puerto Rico, and the Virgin Islands during 1981 was based on projections of the f.a.s. crude oil cost by the International Energy Analysis Division of EIA.

Table 3.19 shows base-case estimates of the balance of payments cost of petroleum imports of \$60.01 billion in 1979, \$86.04 billion in 1980, and \$93.54 billion in 1981.<sup>5</sup> Although imports in physical terms decline between 1979 and 1981, the

<sup>5</sup> Short-Term Analysis Division, Office of Integrative Analysis, Energy Information Administration, *Study of the Federal Oil Imports Reporting Systems*, DOE/EIA-0184/33 (Washington, D.C.: U.S. Department of Energy, 1980).

increasing price of foreign crude results in a net increase in the total import bill. Table 3.20 shows the effect of various scenarios on the balance of payments cost of oil imports into the 50 States, Puerto Rico, and U.S. territories in 1980 and 1981. Similarly, net imports into the 50 States range from 6.72 to 7.28 million barrels per day for 1980 and from 6.40 to 7.57 million barrels per day in 1981. Gross imports into the United States and its territories exceed the 50-State net imports by the amount of exports from the United States and the supplies to meet the domestic demand of Puerto Rico and the territories. On this balance of payments basis, total imports are raised by 0.97 million barrels per day in 1980 and 0.98 million barrels per day in 1981 above the net imports shown for the 50 States.

## NATURAL GAS

### Price Regulation

Until the Natural Gas Policy Act of 1978 (NGPA) became law, sole Federal control over the interstate natural gas industry was through regulations implementing the Natural Gas Act of 1938 (NGA), which the Federal Power Commission (FPC) administered. The Federal Government had authority under the NGA to regulate the purchase and selling price, the conditions of sale, and the rate of return earned by interstate pipelines. However, only the interstate market was regulated; the intrastate market was not subject to FPC jurisdiction.

During the 1960's, prices in the interstate market rose but were limited by the FPC-regulated price. Commitments to the interstate market declined as a consequence. By the winter of 1972, gas demand in some interstate markets began to exceed available supply at the controlled prices. At the same time, an excess of supply was growing in the intrastate market. Corrective measures were taken, but none addressed the underlying causes of the interstate gas shortage until the passage of the NGPA in 1978.

The NGPA made three major changes in the regulatory structure:

- virtually all natural gas production, both interstate and intrastate, came under the jurisdictional authority of the FPC's successor agency, the Federal Energy Regulatory Commission (FERC).

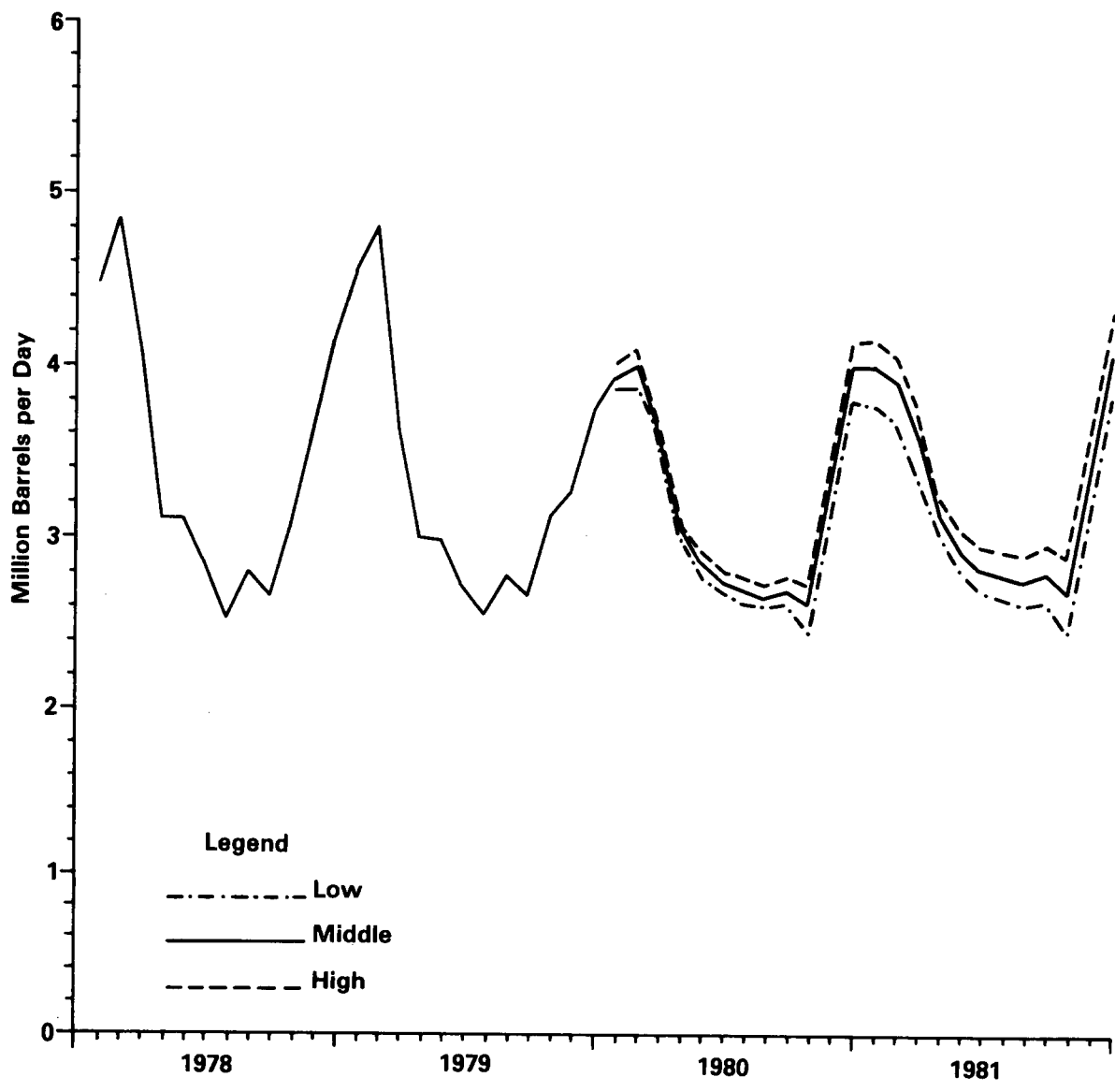

Figure 3.4 Domestic Demand for Distillate Fuel Oil

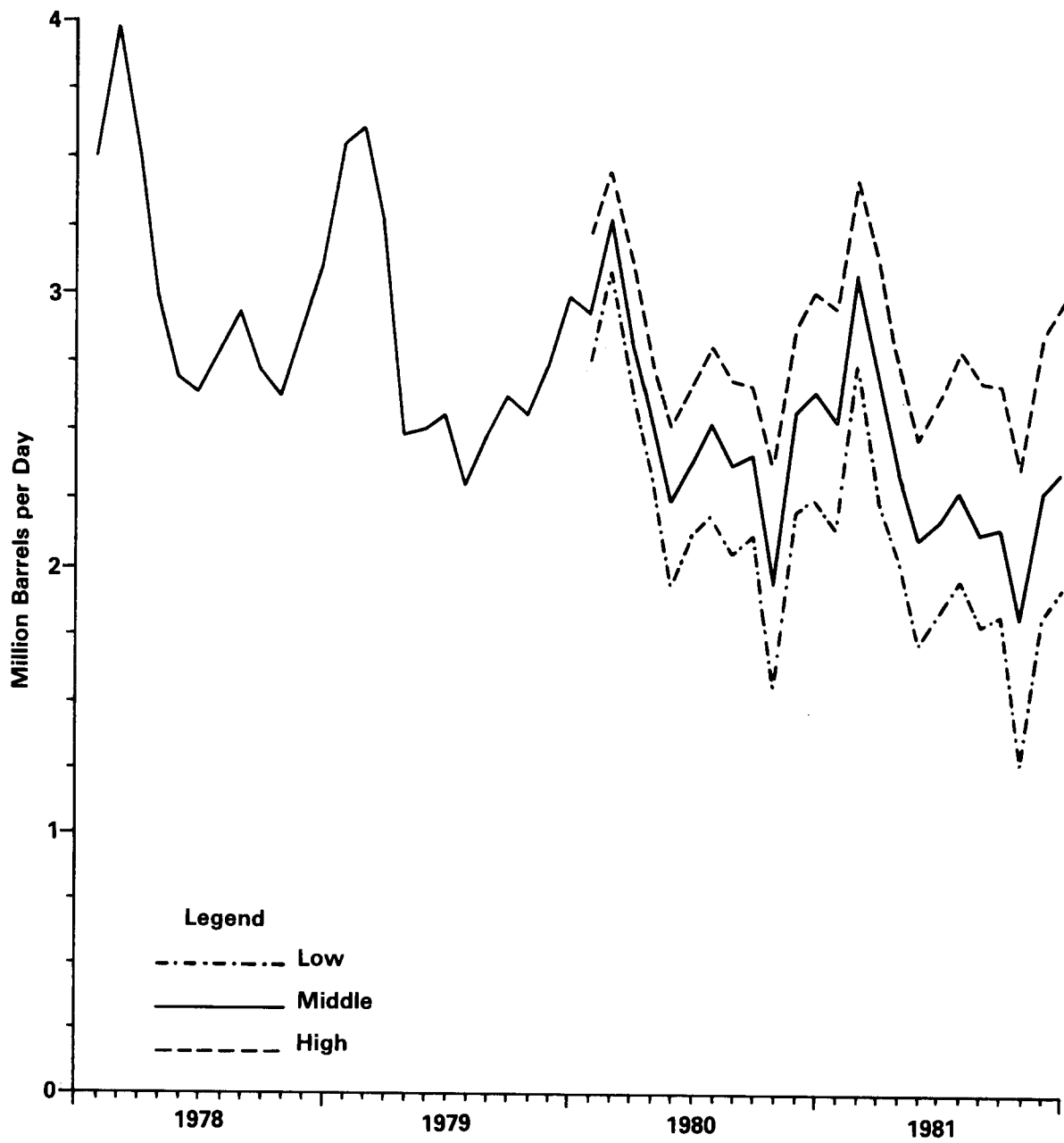

Figure 3.5 Domestic Demand for Residual Fuel Oil

**Table 3.14 Quarterly Supply and Disposition of Distillate Fuel Oil**  
(Million Barrels per Day, Except Stocks)

Base Case	1978					1979				
	Quarter					Quarter				
	1st	2nd	3rd	4th	Total	1st	2nd	3rd	4th	Total
<b>Supply</b>										
Refinery Output.....	3.01	3.11	3.20	3.34	3.17	2.96	3.05	3.33	3.23	3.14
Imports.....	0.20	0.12	0.15	0.22	0.17	0.20	0.17	0.19	0.23	0.20
Exports.....	0.01	0	0	0	0	0	0	0	0	0
Net Imports.....	0.19	0.12	0.15	0.22	0.17	0.20	0.17	0.18	0.22	0.19
<b>Primary Stock Levels</b> (million barrels)										
Opening.....	250.3	137.8	157.2	220.7	250.3	216.4	022.7	141.4	220.3	216.4
Closing.....	137.8	157.2	220.7	216.4	216.4	112.7	141.4	220.3	228.3	228.3
Net Withdrawals (MMBD).....	1.25	-0.21	-0.69	0.05	0.09	1.15	-0.31	-0.86	-0.09	-0.03
Total Primary Supply.....	4.46	3.02	2.66	3.60	3.43	4.30	2.90	2.66	3.37	3.30
<b>Disposition</b>										
Nonutility Shipments.....	4.08	2.88	2.49	3.49	3.23	4.20	2.85	2.62	3.31	3.24
Electric Utility Shipments.....	0.38	0.14	0.17	0.11	0.20	0.11	0.05	0.04	0.05	0.06
Electric Utility Consumption.....	0.33	0.15	0.18	0.15	0.20	0.22	0.12	0.13	0.14	0.15
<b>Electric Utility Stock Levels</b> (million barrels)										
Opening.....	24.63	22.09	22.76	22.76	24.63	20.77	20.48	21.64	23.18	20.77
Closing.....	22.09	22.76	22.76	20.77	20.77	20.48	21.64	23.18	22.71	22.71
Net Additions (MMBD).....	-0.03	0.01	0	-0.02	-0.01	0	0.01	0.02	-0.01	0.01
Electric Utility Discrepancy.....	-0.08	0.01	0.01	0.02	-0.01	0.11	0.08	0.11	0.09	0.09
Discrepancy.....	0	0	0	0	0	0	0	0	0.01	0
Total Disposition.....	4.46	3.02	2.66	3.60	3.43	4.30	2.90	2.66	3.37	3.30

MMBD = Million barrels per day.

Note: Historical data in this table may differ from comparable data in Volume 2 due to rounding error in cumulating from monthly data.

**Table 3.15 Distillate Fuel Oil Demand: Base Case and Scenario Differentials**  
(Million Barrels per Day)

Scenario Cases	1980					1981				
	Quarter					Quarter				
	1st	2nd	3rd	4th	Total	1st	2nd	3rd	4th	Total
<b>Demand in 50 States</b>										
Base Case.....	3.85	2.90	2.69	3.30	3.18	3.81	2.96	2.78	3.36	3.23
<b>Price Sensitivity</b>										
High Price.....	0.02	0	-0.01	-0.05	-0.01	-0.06	0	-0.01	-0.06	-0.03
Low Price.....	-0.01	0	0	0.04	0.01	0.07	0	0	0.10	0.04
<b>Weather Sensitivity</b>										
Favorable Weather.....	-0.05	-0.01	-0.01	-0.06	-0.03	-0.08	-0.01	-0.01	-0.06	-0.04
Adverse Weather.....	0.06	0.01	0.01	0.06	0.03	0.08	0.01	0.01	0.06	0.04
<b>Economic Sensitivity</b>										
High Economics.....	0.02	0.06	0.07	0.09	0.06	0.11	0.12	0.15	0.16	0.13
Low Economics.....	-0.01	-0.06	-0.07	-0.09	-0.06	-0.11	-0.12	-0.15	-0.16	-0.13
High Demand.....	0.07	0.06	0.07	0.12	0.07	0.15	0.12	0.15	0.20	0.15
Low Demand.....	-0.06	-0.06	-0.07	-0.12	-0.07	-0.15	-0.12	-0.15	-0.18	-0.14

Notes: See Tables 3.3 and 3.4 for assumed changes in key variables for price, weather, and economic sensitivities.

Historical data in this table may differ from comparable data in Volume 2 due to rounding error in cumulating from monthly data.

1980					1981				
Quarter				Total	Quarter				Total
1st	2nd	3rd	4th		1st	2nd	3rd	4th	
3.05	2.81	3.14	2.89	2.98	2.78	3.03	3.31	2.96	3.02
0.26	0.11	0.16	0.20	0.18	0.23	0.12	0.18	0.20	0.18
0.01	0.01	0.01	0.01	0.01	0.01	0.01	0.01	0.01	0.01
0.25	0.10	0.16	0.20	0.18	0.23	0.11	0.17	0.20	0.18
228.3	179.0	180.2	236.4	228.3	217.3	145.2	161.4	226.1	217.3
179.0	180.2	236.4	217.3	217.3	145.2	161.4	226.1	207.8	207.8
0.54	-0.01	-0.61	0.21	0.03	0.80	-0.18	-0.70	0.20	0.03
3.85	2.90	2.69	3.30	3.18	3.81	2.96	2.78	3.36	3.23
3.65	2.72	2.44	3.12	2.98	3.62	2.78	2.56	3.21	3.04
0.21	0.18	0.24	0.18	0.20	0.20	0.18	0.22	0.15	0.19
0.24	0.17	0.23	0.18	0.20	0.22	0.17	0.20	0.16	0.19
22.71	20.75	21.55	23.05	22.71	22.70	20.75	21.55	23.05	22.70
20.75	21.55	23.05	22.70	22.70	20.75	21.55	23.05	22.70	22.70
-0.02	0.01	0.02	0	0	-0.02	0.01	0.02	0	0
0	0	0	0	0	0	0	0	0	0
-0.02	0	0	0	-0.01	0	0	0	0	0
3.85	2.90	2.69	3.30	3.18	3.81	2.96	2.78	3.36	3.23

- A pricing scheme establishing a specific set of wellhead prices was put into effect, allowing phased decontrol of most categories of natural gas to be accomplished by 1985.
- Incremental pricing rules were established. As a result, certain low-priority industrial customers will pay a larger share of the first sale acquisition costs of natural gas than other consumers.

As a temporary measure, the NGPA allowed intrastate pipelines to move intrastate gas into the interstate market for a period of up to 2 years without permanently committing the gas to the interstate market. This measure resulted in the dispersion of the surplus gas that had developed in the intrastate market and the alleviation of the shortage in the interstate market that occurred under the previous regulatory structure.

As the price of natural gas is decontrolled, the likelihood of curtailment to firm service customers diminishes. Generally, curtailments are imposed during peakload seasons (winter) on low-priority

customers who must acquiesce to the claims of higher-priority users. Under the NGPA, only small amounts of gas production are currently decontrolled (stripper wells) or will be decontrolled soon (some of the NGPA specified category known as high cost natural gas). To the extent that this permits the price mechanism to make the appropriate allocations, the curtailment issue may be transitory.

The price of natural gas reflects the impact of the NGPA pricing scheme imposing wellhead ceiling prices on the different categories of natural gas. (See Table 3.3.) These categories were established by the NGPA based on physical characteristics of the gas deposits and drilling wells. Because only a portion of the incremental pricing scheme regulations have been implemented recently, their effects were not included in the short-term forecasts of natural gas price.

As a result of these price initiatives, natural gas and alternative fuels will be priced more competitively in some markets. The NGPA will permit

**Table 3.16 Quarterly Supply and Disposition of Residual Fuel Oil**  
(Million Barrels per Day, Except Stocks)

Base Case	1978					1979				
	Quarter				Total	Quarter				Total
	1st	2nd	3rd	4th		1st	2nd	3rd	4th	
<b>Supply</b>										
Refinery Output.....	1.80	1.59	1.62	1.66	1.67	1.81	1.59	1.60	1.73	1.68
Imports.....	1.56	1.28	1.30	1.29	1.36	1.44	1.01	0.94	1.10	1.12
Exports.....	0.02	0.01	0.02	0.01	0.01	0.01	0.01	0.01	0.01	0.01
Net Imports.....	1.54	1.27	1.28	1.28	1.34	1.43	1.01	0.93	1.10	1.11
<b>Primary Stock Levels (million barrels)</b>										
Open.....	90.0	62.4	71.9	81.3	90.0	90.2	72.0	80.9	87.8	90.2
Closed.....	62.4	71.9	81.3	90.2	90.2	72.0	80.9	87.8	95.3	95.3
Net Withdrawals (MMBD).....	0.31	-0.10	-0.10	-0.10	0.00	0.20	-0.10	-0.07	-0.08	-0.01
<b>Total Primary Supply.....</b>	<b>3.65</b>	<b>2.76</b>	<b>2.79</b>	<b>2.84</b>	<b>3.01</b>	<b>3.44</b>	<b>2.50</b>	<b>2.45</b>	<b>2.75</b>	<b>2.78</b>
<b>Disposition</b>										
Nonutility Shipments.....	1.99	1.39	1.36	1.52	1.56	1.95	1.32	1.16	1.58	1.50
Electric Utility Shipments.....	1.68	1.38	1.44	1.34	1.46	1.50	1.19	1.30	1.17	1.29
Electric Utility Consumption.....	1.90	1.29	1.48	1.46	1.53	1.59	1.13	1.25	1.29	1.31
<b>Electric Utility Stock Levels (million barrels)</b>										
Opening.....	118.8	107.0	114.4	115.3	118.8	97.5	91.5	99.5	99.9	97.5
Closing.....	107.0	114.4	115.3	97.5	97.5	91.5	99.5	99.9	97.6	97.6
Net Additions (MMBD).....	-0.13	0.08	0.01	-0.19	-0.06	-0.07	0.09	0.00	-0.03	0.00
Electric Utility Discrepancy.....	0.09	-0.01	0.05	-0.07	0.01	0.02	0.03	-0.05	0.09	0.02
Discrepancy.....	-0.01	-0.01	-0.01	-0.01	-0.01	-0.01	-0.01	-0.01	-0.01	-0.01
<b>Total Disposition.....</b>	<b>3.65</b>	<b>2.76</b>	<b>2.79</b>	<b>2.84</b>	<b>3.01</b>	<b>3.44</b>	<b>2.50</b>	<b>2.45</b>	<b>2.75</b>	<b>2.78</b>

MMBD = Million barrels per day.

Note: Historical data in this table may differ from comparable data in Volume 2 due to rounding error in cumulating from monthly data.

**Table 3.17 Residual Fuel Oil Demand: Base Case and Scenario Differentials**  
(Million Barrels per Day)

Scenario Cases	1980					1981				
	Quarter				Total	Quarter				Total
	1st	2nd	3rd	4th		1st	2nd	3rd	4th	
<b>Demand in 50 States</b>										
Base Case.....	2.99	2.38	2.42	2.37	2.54	2.75	2.19	2.17	2.13	2.31
<b>Price Sensitivity</b>										
High Price.....	-0.17	-0.25	-0.26	-0.37	-0.26	-0.38	-0.34	-0.31	-0.46	-0.37
Low Price.....	0.23	0.25	0.23	0.35	0.26	0.37	0.39	0.50	0.57	0.46
<b>Weather Sensitivity</b>										
Favorable Weather.....	-0.07	-0.05	-0.14	-0.08	-0.09	-0.11	-0.03	-0.08	-0.07	-0.07
Adverse Weather.....	0.11	0.05	0.14	0.09	0.10	0.11	0.03	0.14	0.08	0.09
<b>Economic Sensitivity</b>										
High Economics.....	0.01	0.02	0.03	0.04	0.02	0.04	0.05	0.06	0.06	0.05
Low Economics.....	-0.01	-0.02	-0.03	-0.04	-0.02	-0.04	-0.05	-0.06	-0.06	-0.05
<b>High Demand</b>	0.25	0.25	0.27	0.36	0.28	0.39	0.39	0.52	0.58	0.47
<b>Low Demand</b>	-0.18	-0.26	-0.30	-0.38	-0.28	-0.39	-0.34	-0.33	-0.46	-0.38

Notes: See Tables 3.2, 3.3, and 3.4 for assumed changes in key variables for price, weather, and economic sensitivities.

Historical data in this table may differ from comparable data in Volume 2 due to rounding error in cumulating from monthly data.



1980					1981				
Quarter					Quarter				
1st	2nd	3rd	4th	Total	1st	2nd	3rd	4th	Total
1.77	1.64	1.62	1.67	1.67	1.66	1.41	1.39	1.36	1.45
1.12	0.80	0.87	0.81	0.90	0.98	0.77	0.89	0.81	0.86
0.01	0.01	0.01	0.01	0.01	0.01	0.01	0.01	0.01	0.01
1.11	0.79	0.86	0.80	0.89	0.97	0.76	0.88	0.80	0.85
95.3	84.6	88.9	94.4	95.3	103.2	92.7	90.5	99.0	103.2
84.6	88.9	94.4	103.2	103.2	92.7	90.5	99.0	101.8	101.8
0.12	-0.05	-0.06	-0.10	-0.02	0.12	0.02	-0.09	-0.03	0
2.99	2.38	2.42	2.37	2.54	2.75	2.19	2.17	2.13	2.31
1.58	1.17	0.97	1.19	1.23	1.53	1.18	0.99	1.21	1.23
1.40	1.21	1.45	1.18	1.31	1.21	1.01	1.18	0.92	1.08
1.44	1.08	1.39	1.25	1.29	1.30	0.92	1.12	0.99	1.08
97.6	93.8	105.5	111.3	97.6	104.6	97.3	105.5	111.3	104.6
93.8	105.5	111.3	104.6	104.6	97.3	105.5	111.3	104.6	104.6
-0.04	0.13	0.06	-0.07	0.02	-0.08	0.09	0.06	-0.07	0
0	0	0	0	0	0	0	0	0	0
0.01	0	0	0	0	0	0	0	0	0
2.99	2.38	2.42	2.37	2.54	2.75	2.19	2.17	2.13	2.31

interstate pipelines to compete effectively against intrastate buyers for new onshore gas. Wellhead prices will increase and thereby stimulate natural gas production.

### International Imports

Effective January 1, 1980, the United States authorized the import of up to 300 million cubic feet daily (MMcfd), or about 0.12 trillion cubic feet (Tcf) per year of Mexican natural gas at a border price of \$4.47 per thousand cubic feet (Mcf). Under the present terms of the contract, the price will be adjusted quarterly, based on the price of either imported crude oil or imported Canadian gas, whichever is higher. Import levels are expected to remain at this volume through the end of 1980. The gas will principally service the Southwestern States.

Canadian imports have been rising slowly, and now account for approximately 5-6 percent of

natural gas supply. The price in February 1980 was \$4.47 per Mcf. The price is tied to the price of crude oil imports into Canada. Canadian gas is used principally in the Pacific Northwest, the Northern tier, and the Midwestern States. Because a large portion of the natural gas consumed in these States is the higher priced Canadian gas, the price in these States will be higher than the national average.

The Alaska natural gas pipeline will be constructed in stages. The western leg extending from Alberta, Canada, to Oregon will be completed first, followed by the eastern leg from Canada to the Minnesota-Iowa border. If the current schedule is maintained, the first deliveries of gas from Alberta through the western leg are expected about January 1, 1981, at 100 MMcfd. This delivery is expected to increase to 240 MMcfd by June 1, 1981. By the end of 1981, the eastern leg from the Montana border to Ventura, Iowa, will be completed. Deliveries through the eastern leg are expected to begin at 800 MMcfd.

**Table 3.18 Petroleum Imports: Base Case and Scenario Differentials**  
(Million Barrels per Day)

Scenario Cases	1980					1981				
	Quarter				Total	Quarter				Total
	1st	2nd	3rd	4th		1st	2nd	3rd	4th	
Total Net Imports <sup>a</sup>										
Base Case .....	7.78	6.34	7.08	6.91	7.03	6.64	6.65	7.57	6.89	6.94
Price Sensitivity										
High Price .....	-0.02	-0.34	-0.39	-0.51	-0.31	-0.54	-0.48	-0.50	-0.66	-0.54
Low Price .....	0.01	0.25	0.28	0.45	0.25	0.51	0.48	0.67	0.84	0.63
Weather Sensitivity										
Favorable Weather .....	-0.01	-0.06	-0.17	-0.12	-0.09	-0.19	-0.04	-0.10	-0.10	-0.11
Adverse Weather .....	0.01	0.04	0.16	0.16	0.09	0.19	0.02	0.15	0.16	0.13
Economic Sensitivity										
High Economics .....	0.01	0.17	0.22	0.30	0.17	0.32	0.35	0.46	0.49	0.41
Low Economics .....	-0.01	-0.19	-0.23	-0.26	-0.17	-0.32	-0.38	-0.47	-0.45	-0.41
Motor Gasoline Price										
Elasticity Sensitivity										
High Elasticity .....	-0.01	-0.16	-0.19	-0.17	-0.13	-0.21	-0.25	-0.26	-0.24	-0.24
Low Elasticity .....	0.01	0.15	0.19	0.19	0.14	0.22	0.25	0.26	0.27	0.25
High Demand .....	0.02	0.34	0.43	0.60	0.35	0.67	0.64	0.87	1.02	0.80
Low Demand .....	-0.03	-0.43	-0.52	-0.61	-0.39	-0.69	-0.66	-0.74	-0.84	-0.73

<sup>a</sup>Excludes crude oil for the Strategic Petroleum Reserve (SPR).

Note: See Tables 3.2, 3.3, and 3.4 for assumed changes in key variables for price, weather, and economic sensitivities.

Imports of liquefied natural gas (LNG) are projected to increase in 1980 by 53 percent over 1979, rising from 242 to 370 billion cubic feet (Bcf). These projected increases through 1981 are based on contractual obligations between Sonatrach, the Algerian National Oil Group, and the American company, El Paso, that call for deliveries of 350 Bcf per year to facilities at Cove Point, Maryland and Elba Island, Georgia. An additional 20 Bcf is projected to be delivered to the Everett, Massachusetts facility. Exports are expected to remain steady at 50 Bcf per year. Whether or not these projections will reflect actual deliveries in 1980 and 1981 is uncertain. In April 1980, Algeria refused to ratify the El Paso contract because of a price dispute. Future deliveries of LNG will depend on negotiations between the United States and Algerian governments.

Over the next 2 years, imports may account for 8–10 percent of the total supply. Imports, coupled with the effects of the NGPA, should eliminate natural gas curtailments to firm service customers in the next 2 years.

Although the decline in domestic production, witnessed in the past few years, is projected to

continue through the end of 1981, no real shortages are forecasted. Currently, no shortage is apparent in the intrastate market because excess intrastate gas is still being sold in the interstate market. As this flow between markets declines, the supply will be augmented by imports of Mexican and Canadian gas.

In the base case, natural gas consumption is expected to be 20.6 Tcf in 1980 and 20.1 Tcf in 1981. (See Table 3.21.) The projected slight decline in consumption during the forecast period reflects the continuing decline in domestic production.

The natural gas market will continue to involve a level of uncertainty because of the startup of new, coal electric utility plants, the postponement of nuclear, electric utility plants, and fuel switching and conservation plans by large industrial users.

## COAL

### Production

Historically, demand has been the constraining factor in limiting production in the coal industry. Expectations of continued low growth in coal

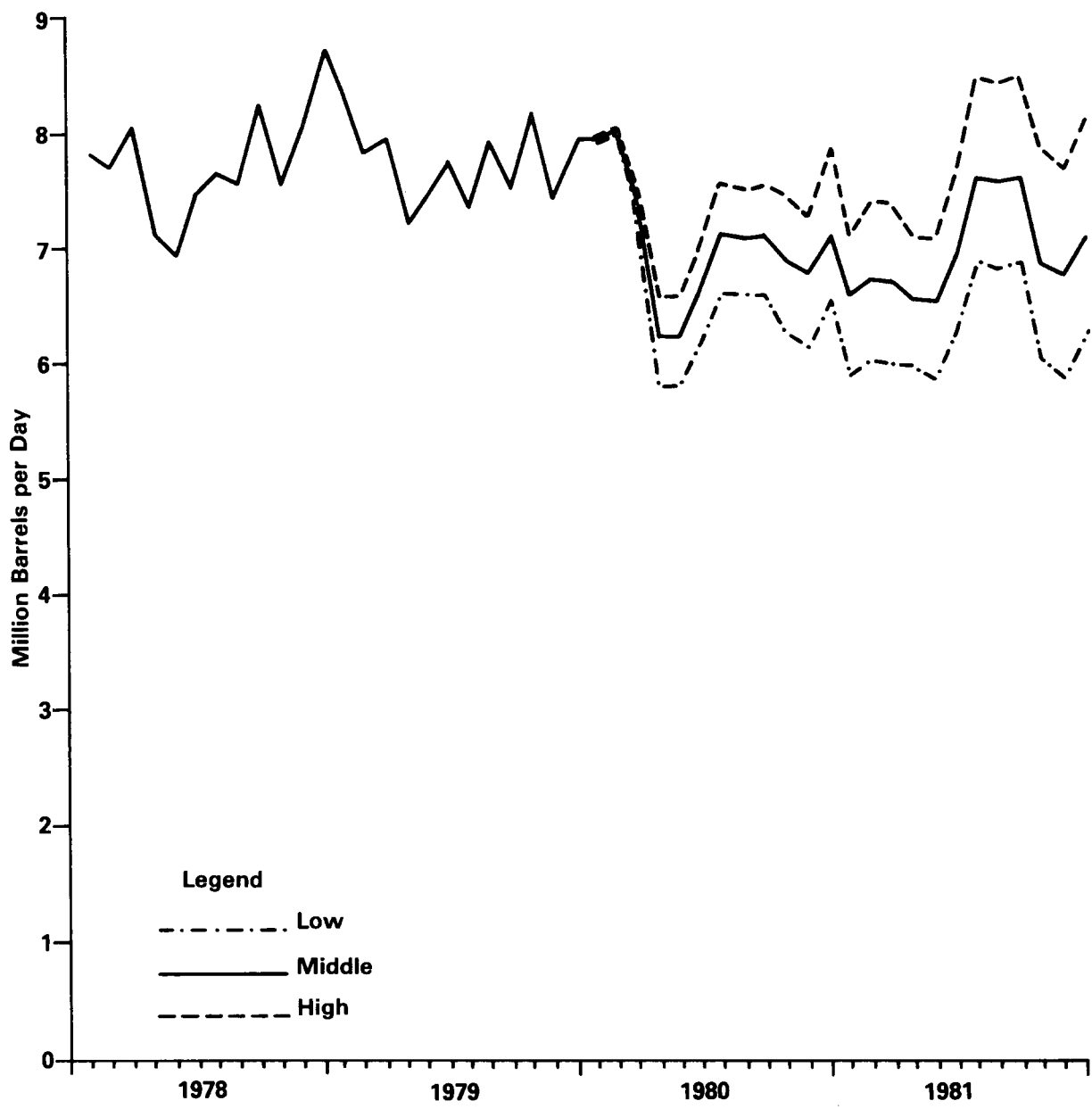

Figure 3.6 U.S. Net Imports of Petroleum Products

**Table 3.19 U.S. Gross Oil Imports by Volume and Cost: Actual and Projected for 1978, 1979, 1980, and 1981**  
(Million Barrels per Day and Current Dollars)

Imports by Volume and Cost	1978 Actual	1979					1980					1981				
		Quarter					Quarter					Quarter				
		1st	2nd	3rd	4th	Year	1st	2nd	3rd	4th	Year	1st	2nd	3rd	4th	Year
50 States Gross Imports (excluding SPR) .....	8.20	8.56	7.93	8.07	8.28	8.21	8.26	6.81	7.56	7.38	7.50	7.13	7.13	8.05	7.37	7.42
Plus SPR .....	0.16	0.17	0.08	0.03	0	0.07	0	0	0	0	0	0	0	0	0	0
Subtotal .....	8.36	8.73	8.01	8.10	8.28	8.28	8.26	6.81	7.56	7.38	7.50	7.13	7.13	8.05	7.37	7.42
Plus Puerto Rico, Territories <sup>a</sup> (Net Imports/Demand) .....	0.36	0.54	0.70	0.52	0.37	0.53	0.50	0.50	0.50	0.50	0.50	0.50	0.50	0.50	0.50	0.50
Balance of Payments <sup>b</sup> Imports (50 States, Puerto Rico and Territories) .....	8.72	9.27	8.71	8.62	8.65	8.81	8.76	7.31	8.06	7.88	8.00	7.63	7.63	8.55	7.87	7.92
Free Alongside Ship Dollar Cost Per Barrel <sup>b</sup> (Crude Oil and Products) .....	13.29	13.95	16.29	20.96	23.68	18.66	28.21	29.10	29.78	30.49	29.38	31.20	31.94	32.69	33.46	32.36
Total Cost (billion dollars) <sup>b</sup> .....	42.31	11.64	12.91	16.62	18.85	60.01	22.49	19.36	22.08	22.10	86.04	21.43	22.18	25.71	24.22	93.54

<sup>a</sup>Difference between balance of payments imports and DOE data for 50 States. Data include net imports (apparent demand) of Puerto Rico, Virgin Islands, and Guam, less imports for military for own use (1978 average 13,000 barrels per day), annual reconciliations with Canada where applicable, and discrepancies between Customs/Census and DOE importing systems.

<sup>b</sup>Bureau of Economic Analysis, Commerce Department, from Census data (not seasonally adjusted).

SPR = Strategic Petroleum Reserve.

consumption has affected expansion. In turn, these expectations reflect limitations on coal consumption imposed by Federal, State, and local governments' regulatory processes. Among these constraints are the new source performance standards, Federal leasing regulations and resultant time lags between production planning and implementation, mine health and safety regulations, strip mining and reclamation policies, local and State zoning ordinances, State regulatory processes, State and Federal taxation policies, and transportation and electrical transmission limitations. All these constraints affect producer costs and consumer prices for coal and restrict access to consumer markets.

In spite of these limits on expansion, production should be sufficient to meet estimated coal demand through 1981. Current EIA estimates of domestic production capacity exceed 800 million tons annually.

The historical data from 1978 and 1979 reflect the effects of the United Mine Workers coal strike of 1977-78 and recovery from the strike on domestic coal production. The current United Mine Workers of America contract expires in March 1981. Observed data shows increased stockpiling at utilities prior to the contract expiration and a draw-down of these stocks afterward. The 1981 projections parallel this observed phenomenon by increasing stocks in the 3-month period preceding

the contract expiration and decreasing stocks in the following quarter. In the event of a coal strike, which is not factored into the projections, the effect on coal stocks could be greater than indicated. The industry's ability to utilize existing excess capacity and quickly expand production was demonstrated following the strike. Domestic production of bituminous, lignite, and anthracite coals exceeded domestic consumption by 100.2 million tons during the remainder of the year. During 1979, production exceeded domestic consumption by 94.8 million tons.

From December 1977 through March 1978, the strike reduced coal production by 56 percent compared with the preceding 4-month period. During the same time, domestic coal consumption decreased by only 4 percent. This moderate decrease in consumption was largely due to a near-stoppage of coal exports and to a 90 million ton decrease in coal stocks during the strike. During the 3-month period immediately preceding the coal strike, industrial consumers, retail dealers, and utilities had increased their stocks of coal to an historic high of 173 million tons in anticipation of a work stoppage.

The projected 5 million ton production decrease from 1979 to 1980 is due to the relatively mild fall and winter of 1979-80 and the unplanned stockpiling of coal in 1979 during this period of unexpectedly low consumption.

**Table 3.20 Effect of Different Scenarios upon Balance of Payments Cost for Oil Imports in 1980**  
(Volumes in Million Barrels per Day)

Scenario	50-State Imports (net)		Balance of Payments Imports (gross)		Average Cost (dollars per barrel, (f.a.s.))		Total Cost (billion dollars)	
	1980	1981	1980	1981	1980	1981	1980	1981
Base Case .....	7.03	6.94	8.00	7.92	29.38	32.36	86.04	93.54
High Economy .....	7.20	7.35	8.17	8.33	29.38	32.36	87.85	97.15
Low Economy .....	6.86	6.53	7.83	7.51	29.38	32.36	84.20	88.65
Favorable Weather .....	6.94	6.83	7.91	7.81	29.38	32.36	85.06	92.19
Adverse Weather .....	7.12	7.07	8.09	8.05	29.38	32.36	86.99	95.02
High Prices .....	6.72	6.40	7.70	7.38	32.34	35.55	91.14	95.76
Low Prices .....	7.28	7.57	8.25	8.55	27.66	27.77	83.52	86.66

f.a.s. = free alongside ship.

**Table 3.21 Quarterly Supply and Disposition of Natural Gas**  
(Trillion Cubic Feet)

Base Case	1978					1979				
	Quarter				Total	Quarter				Total
	1st	2nd	3rd	4th		1st	2nd	3rd	4th	
<b>Supply</b>										
Production (Dry Gas) .....	4.92	4.74	4.72	4.74	19.12	4.80	4.67	4.60	4.77	18.83
Net Imports (Dry Gas) .....	0.24	0.21	0.19	0.24	0.89	0.25	0.24	0.22	0.27	0.99
Net Imports of LNG .....	-0.01	0	0.01	0.03	0.02	0.04	0.06	0.06	0.03	0.19
SNG Production .....	0.08	0.05	0.05	0.07	0.25	0.07	0.04	0.04	0.06	0.22
<b>Total New Supply</b> .....	<b>5.23</b>	<b>5.00</b>	<b>4.97</b>	<b>5.07</b>	<b>20.28</b>	<b>5.16</b>	<b>5.01</b>	<b>4.92</b>	<b>5.13</b>	<b>20.23</b>
<b>Underground Storage</b>										
Opening .....	5.84	4.50	5.22	6.22	5.84	6.00	4.69	5.40	6.40	6.00
Closing .....	4.50	5.22	6.22	6.00	6.00	4.69	5.40	6.40	6.30	6.30
Net Withdrawals .....	1.35	-0.72	-1.01	0.23	-0.15	1.30	-0.70	-1.00	0.10	-0.30
<b>Total Primary Supply</b> .....	<b>6.58</b>	<b>4.28</b>	<b>3.97</b>	<b>5.30</b>	<b>20.13</b>	<b>6.47</b>	<b>4.31</b>	<b>3.92</b>	<b>5.23</b>	<b>19.93</b>
<b>Disposition</b>										
Electric Utilities .....	0.67	0.81	1.00	0.71	3.19	0.72	0.86	1.08	0.83	3.49
Refinery Fuel .....	0.19	0.20	0.21	0.21	0.81	0.20	0.20	0.21	0.21	0.82
All Other Uses* .....	5.65	3.22	2.70	4.31	15.88	5.51	3.16	2.58	4.14	15.39
Subtotal .....	6.52	4.22	3.91	5.23	19.87	6.43	4.22	3.87	5.19	19.71
Discrepancy .....	0.06	0.06	0.06	0.07	0.25	0.04	0.09	0.05	0.05	0.22
<b>Total Disposition</b> .....	<b>6.58</b>	<b>4.28</b>	<b>3.97</b>	<b>5.30</b>	<b>20.13</b>	<b>6.47</b>	<b>4.31</b>	<b>3.92</b>	<b>5.23</b>	<b>19.93</b>

\*Includes residential, commercial, industrial, and plant and pipeline fuel uses plus synthetic natural gas.

LNG = Liquefied Natural Gas.

SNG = Synthetic Natural Gas.

Note: Historical data in this table may differ from comparable data in Volume 2 due to rounding error in cumulating from monthly data.

During 1979, stocks increased by 34 million tons—20 million tons more than projected in the February 1980 *Short-Term Energy Outlook*. Consequently, stocks of coal are expected to show little change during 1980. In terms of days' supply, stocks are projected to remain relatively constant through 1981.

The EIA projection for western coal production capacity exceeds 285 million tons by the end of 1980.<sup>6</sup> Although the impact on total energy is somewhat less because western coal is generally lower in thermal content than eastern coal, the tonnage figures represent a 90 percent increase in western coal production capacity since 1977.

Several reasons for the relatively large increases in western coal production and production

capacity are found. First, demographic shifts reflect increasing western populations and consequent increased demand for regional coal-fired electrical generation. Second, mandated shifts to coal in the West are met by western production. Third, EPA and New Source Performance Standards restrictions on sulfur dioxide emissions from coal-burning electrical utilities and Major Fuel Burning Installations (MFBI) provide an incentive to use relatively clean-burning, low-sulfur western coal. This type of coal permits lower cost pollution control technology than is necessary for the clean burning of medium- and high-sulfur content eastern coal.

## Consumption

Total consumption in 1979 reached 677.7 million tons, a 5.2-percent annual increase over 1978. (See Table 3.22.) In 1980 and 1981, consumption is

<sup>6</sup> Division of Coal Production Technology, Energy Information Administration, U.S. Department of Energy, *Western Coal Development Monitoring System, A Survey of Coal Mining Capacity in the West*, (Washington, D.C.: U.S. Department of Energy, 1979).

1980					1981				
Quarter				Total	Quarter				Total
1st	2nd	3rd	4th		1st	2nd	3rd	4th	
4.82	4.62	4.59	4.62	18.65	4.68	4.60	4.49	4.67	18.43
0.34	0.33	0.32	0.35	1.34	0.36	0.33	0.33	0.35	1.38
0.05	0.07	0.07	0.07	0.26	0.08	0.08	0.08	0.08	0.33
0.06	0.04	0.04	0.05	0.18	0.05	0.03	0.03	0.04	0.15
5.27	5.06	5.02	5.09	20.44	5.17	5.05	4.93	5.15	20.29
6.30	5.21	5.66	6.66	6.30	6.15	5.19	5.78	6.83	6.15
5.21	5.66	6.66	6.15	6.15	5.19	5.78	6.83	6.32	6.32
1.08	-0.45	-1.00	0.51	0.15	0.96	-0.60	-1.05	0.51	-0.17
6.35	4.61	4.02	5.60	20.59	6.13	4.45	3.88	5.66	20.13
0.71	0.86	1.09	0.74	3.41	0.68	0.82	1.09	0.70	3.29
0.23	0.22	0.23	0.22	0.89	0.21	0.22	0.23	0.22	0.88
5.42	3.53	2.70	4.64	16.29	5.24	3.41	2.56	4.74	15.96
6.35	4.61	4.02	5.60	20.59	6.13	4.45	3.88	5.66	20.13
0	0	0	0	0	0	0	0	0	0
6.35	4.61	4.02	5.60	20.59	6.13	4.45	3.88	5.66	20.13

projected to increase at an annual rate of about 4.5 percent to 740.4 million tons by the end of 1981. The increase in total coal consumption for 1979 reflects increased coal-generating capacity. More significantly, it reflects recovery from the low levels of consumption because of supply shortage effects of the 1977-78 coal strike.

Coal consumed to generate electricity increased by 9.9 percent during 1979 to 528.8 million tons, and it is expected to increase 5.8 percent annually through 1980 and 1981 to 550.6 million tons and 592 million tons, respectively. Again, as viewed against the effects of, and recovery from, the 1978 strike, it is significant that the figure for 1979 represents a 10.8 percent increase over the 1977 consumption of coal by electric utilities, although coal consumption by electric utilities increased by less than 1 percent in 1978 relative to 1977. Moreover, the amount of coal required to produce 1 kWh of electricity increased from 0.95 pounds during the 1974-76 period to 0.99 pounds during 1978. This increase in coal weight per kWh is largely due to

increased use of western steam coals that have a lower heat content per pound than eastern coals. Low-Btu, low-sulfur western coal by weight as a percentage of total coal purchased by electric utilities, increased from 20.7 percent in 1975 to 31.4 percent in 1979.

Domestic consumption of coking coal increased by 6.6 percent to 76.1 million tons in 1979, as the industry recovered from the effects of the 1978 coal strike. However, because of the strong relationship between the demand for iron and steel and the production of coke, coke consumption is expected to decline by 1.4 percent in 1980 in response to the forecasted economic slowdown.

For the first time since 1964-65, consumption of coal by the retail and general industry sectors has increased—from 72.6 million tons in 1978 to 75.4 million tons in 1979. Higher prices for alternative fuels and the effects of recent legislation have acted to temporarily reverse the long-term declining trend that existed, uninterrupted, from 1964 through 1978. Higher petroleum prices and in-

**Table 3.22 Quarterly Supply and Disposition of Coal**  
(Million Short Tons)

Base Case	1978					1979				
	Quarter				Annual Total	Quarter				Annual Total
	1st	2nd	3rd	4th		1st	2nd	3rd	4th	
<b>Supply</b>										
Production .....	87.86	198.54	179.86	203.90	670.16	176.88	201.58	191.93	205.35	775.74
Imports .....	0.53	1.03	0.74	0.66	2.95	0.56	0.48	0.59	0.43	2.06
Exports .....	1.86	12.51	10.66	15.65	40.69	10.97	17.46	17.69	19.89	66.02
<b>Total New Domestic Supply .....</b>	<b>86.53</b>	<b>187.05</b>	<b>169.93</b>	<b>188.90</b>	<b>632.42</b>	<b>166.47</b>	<b>184.60</b>	<b>174.83</b>	<b>185.89</b>	<b>711.78</b>
<b>Secondary Stock Levels*</b>										
Opening .....	157.32	87.40	126.69	129.41	157.32	145.55	133.91	154.81	157.96	145.55
Closing .....	87.40	126.69	129.41	145.55	145.55	133.91	154.81	157.96	179.62	179.62
Net Withdrawals .....	69.91	-39.29	-2.71	-16.14	11.77	11.64	-20.90	-3.15	-21.66	-34.07
<b>Total Indicated Consumption .....</b>	<b>156.45</b>	<b>147.76</b>	<b>167.22</b>	<b>172.76</b>	<b>644.19</b>	<b>178.10</b>	<b>163.70</b>	<b>171.68</b>	<b>164.23</b>	<b>677.72</b>
<b>Disposition</b>										
Domestic Consumption										
Coke Plants .....	13.62	18.35	19.43	19.99	71.39	19.28	19.63	19.21	18.94	77.06
Electric Utilities .....	112.55	112.61	132.80	123.27	481.23	132.32	124.52	138.93	133.03	528.80
Retail and General Industry .....	16.92	17.53	17.05	21.10	72.60	20.83	17.63	17.73	19.16	75.35
Discrepancy .....	13.36	-0.73	-2.06	8.40	18.97	5.68	1.92	-4.20	-6.90	-3.50
<b>Total Disposition .....</b>	<b>156.45</b>	<b>147.76</b>	<b>167.22</b>	<b>172.76</b>	<b>644.19</b>	<b>178.10</b>	<b>163.70</b>	<b>171.68</b>	<b>164.23</b>	<b>677.72</b>

\*Primary stocks (mine, preparation plant, distribution point) are not currently accounted for in the projections.

Note: Historical data in this table may differ from comparable data in Volume 2 due to rounding error in cumulating from monthly data or to alternative methods of handling data on stocks.

creases in natural gas prices to the industrial sector under the provisions of the Natural Gas Policy Act of 1978 are expected to have significant continuing impact on industrial and retail coal consumption. Also, the Powerplant and Industrial Fuel Use Act of 1978 mandates the conversion of industrial boilers from petroleum and natural gas to coal and prohibits new utilization of oil- and gas-fired industrial boilers.

Nonetheless, because of the forecasted economic slowdown, coal consumption in the general industry and retail sectors is expected to decline slightly in 1980 and to remain constant at 1980 levels through 1981.

## COMPARISON WITH THE 1978 ANNUAL REPORT FORECAST

This section compares the forecasts that appear in this report with the forecasts that appeared in the Energy Information Administration's, *Annual Report to Congress, 1978, Volume Three*. Table 3.23 summarizes and compares the 1978 and 1979 *Annual Report* forecasts for 1980 and compares the 1978 *Annual Report* forecasts for 1979 with

recently published historical data from 1978 and 1979.

Domestic production of crude oil and lease condensate in 1980 is now expected to be slightly higher than had been anticipated in the 1978 *Annual Report*. This increase reflects the offsetting effects of slightly lower production estimated for sub-Arctic areas (Lower-48 States and south Alaska) and a higher flow rate from Alaska North Slope fields rising to 1.52 million barrels per day compared with an estimate of 1.1-1.4 million barrels per day in the 1978 *Annual Report*.

The new estimate of 1980 coal and natural gas production changed by less than 1 percent from the 1978 *Annual Report* production estimates.

The 1978 *Annual Report* estimate of 362 billion kWh generation from nuclear plants in 1980 did not anticipate the full effects of the moratorium on licensing and startup of new plants. The Nuclear Regulatory Commission imposed a licensing moratorium shortly after the Three Mile Island accident and the possibility still exists that the moratorium could continue through 1980. That extension would preclude the possibility of oil displacement by 4,300 MW of nuclear capacity scheduled to begin commercial service in 1980. The



1980					1981				
Quarter				Annual Total	Quarter				Annual Total
1st	2nd	3rd	4th		1st	2nd	3rd	4th	
174.60	192.56	188.21	215.35	770.71	191.04	149.15	221.43	241.42	803.04
0.54	0.73	0.67	0.69	2.63	0.59	0.78	0.72	0.74	2.84
12.23	20.89	18.16	18.84	70.11	13.25	18.00	19.57	20.38	71.21
162.92	172.39	170.72	197.20	703.23	178.38	131.92	202.59	221.78	734.66
179.62	172.33	176.54	165.08	179.62	183.93	183.93	138.77	147.31	183.93
172.33	176.54	165.08	183.93	183.93	183.93	138.77	147.31	178.21	178.21
7.28	-4.21	11.46	-18.85	-4.32	0	45.16	-8.54	-30.90	5.72
170.20	168.19	182.19	178.34	698.92	178.38	177.08	194.05	190.88	740.39
17.56	19.56	19.14	19.15	75.40	17.56	19.56	19.14	19.15	75.40
133.30	131.40	146.55	139.33	550.58	141.47	140.42	158.36	151.77	592.02
19.35	17.23	16.51	19.84	72.93	19.35	17.23	16.51	19.84	72.93
0	0	-0.01	0.02	0.01	0.01	-0.13	0.04	0.12	0.04
170.20	168.19	182.19	178.34	698.92	178.38	177.08	194.05	190.88	740.39

new forecast is for nuclear generation in 1980 to be 273 billion kWh, up 7 percent from the actual 1979 generation, but 25 percent below the estimate for 1980 in the 1978 *Annual Report*.

The coal-fired generation forecast remains the same for both the 1978 and 1979 *Annual Reports*, at 1,125 billion kWh. Two factors strongly affecting the coal-fired generation forecast are the trend in increased calendar time in commercial service of coal-fired units and expectations of an additional 16,000 MW of new capacity in 1980. Because many of these new units are being brought into service to meet an expected new load, a possibility exists that service dates will be delayed if that new load does not materialize.

### Demand Forecast

Detailed comparisons of demand forecasts for petroleum products are only presented for the base demand case. In general, the range of forecasts for the current report is lower than the range of demand forecasts for the 1978 *Annual Report*, although an overlap within the ranges prepared for the sensitivity analyses does occur.

Demand forecasts for motor gasoline are significantly lower in the 1979 *Annual Report*. This difference can be attributed mainly to forecasts of slower real economic activity and to higher prices, projected to average \$1.33 per gallon in 1980.

Higher prices also cause reductions in the forecasts for distillate fuel oil demand. Distillate demand in 1980 is now expected to be 3.19 million barrels per day, compared with the projection of 3.60 million barrels per day in the 1978 *Annual Report*, more than 11 percent lower. Wholesale prices for distillate are projected to average 89.1 cents per gallon during 1980.

Projections of residual fuel oil demand decrease from the 1978 *Annual Report* because of higher fuel prices for industrial use and reduced utility consumption caused by higher electricity generation from other sources. Demand forecasts for residual fuel oil are about 410,000 barrels per day lower in the current forecast compared with the 1978 *Annual Report*. Higher price forecasts (\$26.54 per barrel in 1980) together with fuel switching by electric utilities to other fuels are mainly responsible for the decline.

Total demand for petroleum products is projected to be as low as 17.11 million barrels per day in

**Table 3.23 Energy Supply and Demand: History and Alternative Projections, Mid-Demand/Mid-Supply, 1978–1980**

	1978	1979		1980	
	History	Forecast Annual Report 1978	History	Forecast Annual Report 1978	Forecast Annual Report 1979
<b>Total Energy</b>					
		(dollars per barrel)			
World Oil Prices*	14.57	16.55	21.54	18.53	33.51
		(quadrillion Btu)			
Domestic Production	61.59	<sup>a</sup> 62.65	63.24	<sup>b</sup> 63.46	63.14
Net Imports	16.85	<sup>b</sup> 17.04	16.07	<sup>b</sup> 17.94	14.84
Stock Withdrawals	0.36	NA	-0.54	NA	-0.04
Total Available	78.80	<sup>b</sup> 79.69	78.76	<sup>b</sup> 81.40	77.94
Petroleum	38.02	<sup>c</sup> 38.32	36.71	<sup>c</sup> 38.95	35.28
Natural Gas	20.30	<sup>c</sup> 19.87	20.13	<sup>c</sup> 19.65	20.84
Coal	14.61	<sup>c</sup> 14.96	15.29	<sup>c</sup> 15.72	15.61
Other <sup>d</sup>	6.04	<sup>e</sup> 6.49	5.82	<sup>e</sup> 7.03	6.08
		(million short tons)			
Coal					
Production	670	NA	776	766	771
Consumption	644	<sup>a</sup> 676	678	<sup>a</sup> 711	699
		(trillion cubic feet)			
Natural Gas					
Production	19.12	<sup>f</sup> 18.87	18.83	<sup>f</sup> 18.72	18.65
Consumption	19.87	<sup>f</sup> 19.74	19.71	<sup>f</sup> 19.53	20.59
		(billion kilowatt hours)			
Nuclear Generation	276	NA	255	<sup>g</sup> 362	273
Hydro Generation/Other	284	NA	284	<sup>g</sup> 292	291
		(million barrels per day)			
Petroleum					
Crude Oil Production	8.70	<sup>h</sup> 8.61	8.51	<sup>h</sup> 8.43	8.55
Other Liquids Supply	2.10	<sup>h</sup> 2.21	2.19	<sup>h</sup> 2.19	2.11
Total Domestic	10.80	<sup>h</sup> 10.82	10.70	<sup>h</sup> 10.62	10.66
Net Imports	7.84	<sup>h</sup> 8.36	7.74	<sup>h</sup> 8.88	7.03
Stock Withdrawals	0.26	NA	-0.10	NA	-0.10
Total Available	18.90	<sup>h</sup> 19.18	18.34	<sup>h</sup> 19.50	17.58
Products Supplied:					
Motor Gasoline	7.41	<sup>h</sup> 7.69	7.03	<sup>h</sup> 7.74	6.68
Distillate Fuel Oil	3.43	<sup>h</sup> 3.52	3.30	<sup>h</sup> 3.60	3.19
Residual Fuel Oil	3.02	<sup>h</sup> 2.91	2.79	<sup>h</sup> 2.95	2.54
Other	4.99	<sup>h</sup> 5.06	5.28	<sup>h</sup> 5.21	5.17

\*Current average U.S. refiners' acquisition cost of imported crude oil, U.S. dollars per barrel (42 gallons).

<sup>a</sup>Sum of components may not equal total due to independent rounding.

<sup>b</sup>Source: *Annual Report 1978*, p. 43, Table 3.3.

<sup>c</sup>Source: *Annual Report 1978*, p. 46, Table 3.7.

<sup>d</sup>Includes nuclear, geothermal, hydroelectric power, and other inputs into electrical generation.

<sup>e</sup>Source: *Annual Report 1978*, p. 46, Table 3.8.

<sup>f</sup>Source: *Annual Report 1978*, p. 240, Table 14.1.

<sup>g</sup>Source: *Annual Report 1978*, p. 251, Table 15.1.

<sup>h</sup>Source: *Annual Report 1978*, p. 265, Table 16.2.

**Table 3.24 Energy Supply and Demand: Mid Demand/Mid Supply, 1980; Comparisons with Other Forecasts**

Petroleum (million barrels per day)	EIA Annual Report 1979	EIA <sup>a</sup> Feb 1980	EIA <sup>b</sup> Oct 1979	DRI <sup>c</sup> Wntr 1980	IPAA <sup>d</sup> Oct 1979	OGJ <sup>e</sup> Jan 1980	Pace <sup>f</sup> Oct 1979	Shell <sup>g</sup> Jan 1980
<b>Supply</b>								
Domestic Production								
Crude Oil	8.55	8.58	8.63	8.55	8.56	8.55	8.80	8.50
NGL	1.60	1.60	1.70	1.70	1.67	1.70	—	1.70
Other Domestic Production <sup>h</sup>	0.52	0.51	0.52	—	0.56	0.53	—	0.50
Total Domestic Production	10.66	10.69	10.84	10.25	10.79	10.78	—	10.70
Imports								
Crude Oil	5.90	6.02	—	5.53	6.45	6.12	6.08	6.00
Products	1.61	1.60	—	1.79	1.67	1.60	1.64	1.70
Total Imports	7.50	7.62	—	7.42	8.12	7.72	—	7.70
Exports								
Crude Oil	0.25	0.38	—	—	0.24	—	—	—
Products	0.23	0.22	—	—	0.21	—	—	—
Total Exports	0.48	0.60	—	—	0.45	0.45	—	0.40
Net Imports	7.03	7.02	7.40	—	7.67	7.27	—	—
Net Stock Withdrawals	-0.10	-0.07	0	—	-0.08	-0.04	—	-0.10
Net Domestic Supply	17.58	17.64	18.24	—	18.38	18.01	—	17.90
<b>Consumption</b>								
Motor Gasoline	6.68	6.86	7.17	6.77	7.25	6.86	7.30	7.00
Distillate Fuel Oil	3.19	3.21	3.22	—	3.22	3.36	3.36	3.30
Residual Fuel Oil	2.54	2.40	2.71	—	2.64	2.59	3.52	2.60
Other Products	5.17	5.17	5.06	—	5.27	5.21	4.40	5.00
Total Domestic Consumption	17.58	17.64	18.15	—	18.38	18.01	18.58	17.90
<b>Natural Gas (trillion cubic feet)</b>								
	EIA Annual Report 1979	EIA Feb 1980	EIA Oct 1979	DRI Wntr 1980	IPAA Oct 1979	OGJ Jan 1980	Pace Oct 1979	Shell Jan 1980
<b>Supply</b>								
Domestic Production								
Marketed Dry Gas <sup>i</sup>	18.65	18.65	18.65	18.61	—	—	19.00	—
Synthetic Gas	0.18	0.18	0.18	—	—	—	—	—
Net Imports <sup>k</sup>	1.60	1.18	1.15	1.18	—	—	1.18	—
Net Stock Withdrawals	0.15	-0.14	-0.13	—	—	—	—	—
Net Domestic Supply	20.59	19.88	19.85	—	—	—	—	—
<b>Consumption</b>								
Electric Utilities	3.41	3.31	3.15	—	—	—	—	—
Refinery Fuel	0.89	0.89	0.90	—	—	—	—	—
Other	16.29	15.67	15.80	—	—	—	—	—
Total Domestic Consumption	20.59	19.88	19.85	—	—	—	—	—
<b>Coal (million tons)</b>								
	EIA Annual Report 1979	EIA Feb 1980	EIA Oct 1979	EIA Wntr 1980	DR Dec 1979	NCA <sup>m</sup> Nov 1979	C.O. <sup>l,n</sup> Oct 1979	Pace Jan 1980
<b>Supply</b>								
Domestic Production	770.7	801.9	752.0	754.0	776.0	842.4	815.9	—
Exports	70.1	65.0	50.2	69.5	—	60.0	—	—
Imports	2.6	3.3	3.4	2.4	—	—	—	—
Net Imports	-67.5	-61.8	-46.8	-67.1	—	—	-54.0	—
Net Stock Withdrawals	-4.3	-18.3	-5.6	-12.4	—	—	—	—
Net Domestic Supply	698.9	721.9	699.6	—	—	—	762.0	—
<b>Consumption</b>								
Electric Utilities	550.6	576.7	554.4	556.5	555.0	554.0	593.0	—
Coke Plants	75.4	75.1	75.2	72.1	75.0	76.0	—	—
Other	72.9	70.1	70.1	58.3	73.0	71.0	—	—
Total Domestic Consumption	698.9	721.9	699.7	686.9	—	701.0	762.0	—

**Table 3.24 Energy Supply and Demand: Mid Demand/Mid Supply, 1980; Comparisons with Other Forecasts (Continued)**

	EIA Annual Report	EIA Feb 1980	EIA Oct 1979	DRI Wntr 1980	EEP Apr 1979	EW <sup>a</sup> Sep 1980	Pace Oct	Shell Jan
Electrical Power (billion kilowatt hours)								
Generation by Fuel Type								
Petroleum .....	304.9	279.9	320.5	254.6	394.0	—	—	288.0
Coal .....	1,125.1	1,150.2	1,106.4	1,123.6	1,177.0	—	—	1,095.0
Natural Gas .....	326.2	317.0	301.3	387.4	240.3	—	—	345.0
Nuclear .....	273.4	274.2	326.7	303.6	364.8	—	288.5	272.0
Hydroelectric .....	286.5	286.5	283.1	292.4	247.9	—	—	275.0
Geothermal and Other .....	4.2	4.1	3.7	4.4	15.1	—	—	4.0
Total Generation .....	2,320.3	2,311.8	2,341.7	2,266.0	2,439.1	2,130.0	—	2,279.0
Net Imports .....	17.2	17.2	17.2	—	—	—	12.5	—
Total Domestic Supply .....	2,337.5	2,329.0	2,358.9	—	—	—	2,500.0	—
Conversion and Transmission Losses .....	208.8	208.1	210.8	—	—	—	—	—
Net Domestic Disposition .....	2,128.7	2,120.9	2,148.1	—	—	—	—	—

<sup>a</sup>U.S. Department of Energy, Energy Information Administration, Office of Integrative Analysis, *Short-Term Energy Outlook*, February 1980.

<sup>b</sup>U.S. Department of Energy, Energy Information Administration, Office of Integrative Analysis, *Short-Term Energy Outlook*, October 1979.

<sup>c</sup>Data Resources, Inc., *Energy Review—Winter 1980*, 1980.

<sup>d</sup>Independent Petroleum Association of America, *Report of the Supply and Demand Committee*, October 27, 1979.

<sup>e</sup>Petroleum Publishing Co., *Oil and Gas Journal*, Vol. 78, No. 4, January 28, 1980.

<sup>f</sup>The Pace Company, *The Pace Energy and Petrochemical Outlook to 2000*, October 1979.

<sup>g</sup>Scallop Corporation, *World Oil Outlook*, January 1980.

<sup>h</sup>Include processing gain.

<sup>i</sup>Includes strategic petroleum reserve imports.

<sup>j</sup>Excludes SNG.

<sup>k</sup>Includes LNG.

<sup>l</sup>Excludes anthracite.

<sup>m</sup>National Coal Association, "Coal Production Expected to Advance in West, Stay Level in East in 1980, NCA Says," Press Release, December 1979.

<sup>n</sup>Price, Joel, *The Coal Observer*, Dean Witter Reynolds, Inc., November 1979.

<sup>o</sup>Implied production.

<sup>p</sup>Edison Electric Institute, *1979 Annual Electric Power Survey*, April 1979.

<sup>q</sup>McGraw-Hill Inc., *Electrical World* Vol. 192, No. 6, September 15, 1979.

Note: Where blank spaces appear in the table, comparative data were not available or were presented in non-comparable standard units without conversion data sufficient for comparative analysis.

1980 (compared with a low of 18.05 million barrels per day projected in the 1978 *Annual Report*), and as high as 17.99 million barrels daily (compared with a high of 20.32 million barrels per day projected in the 1978 *Annual Report*).

### Comparison with Other Forecasts

Table 3.24 compares EIA's forecasts of demand for petroleum products, electric power, natural gas, and coal with various projections made by industry associations. With the information available, it has not been possible to compare the assumptions, structure, data base, or methodology underlying the various forecasts. Table 3.24 compares only their published results.

The first section of Table 3.24 shows EIA's current forecast of domestic petroleum production at about the same level as other forecasts. However, petroleum demand is projected lower than

other forecasts and EIA oil imports are next to the lowest of the eight analyses chosen for the petroleum forecast comparison. Total domestic production, forecast by EIA, in this table is nearly identical to the average of the other forecasts. Only DRI forecasts lower total imports for 1980 than does EIA, and EIA's current forecast for total domestic consumption is the lowest in the comparison.

Of significance in these comparisons is the closeness among several forecasts of the various items in the table. The differences in the high and low forecasts for total domestic production, total imports, and total domestic consumption are 5.4 percent, 8.6 percent, and 4.4 percent, respectively (i.e., the difference between the high and low figures, divided by the high figure). Only one of the forecasts in the sample data, the Pace Company's, is predicting an increase in 1980 total consumption, relative to preliminary figures for 1979

consumption. Note, however, that this and two other forecasts were issued prior to the notable reductions in demand because of warm weather and to an apparent cutback in gasoline use early in 1980.

Forecasts of electric power demand were made in several different forms—generation or output compared with electric utility sales and a 50-State versus a 48-State basis. The current forecast is for total electricity generation of 2.32 trillion kWh in 1980, an increase of 3.2 percent over 1979.

In September 1979, the trade magazine *Electrical World* forecasted that sales in 1979 would be 3.4 percent above 1978, with sales in 1980, 2 percent above 1979. Forecasts for 1980 by DRI and Shell are lower than EIA's, but the Edison Electric Institute forecasts a higher level.

The EIA's forecast of production of dry natural gas in the 50 States is now 18.7 Tcf in 1980, a decrease of 1 percent from 1979, which showed a 2 percent decrease from 1978.

The highest estimate for coal production in 1980 is that of the *Coal Observer*, which forecasts production of 842 million short tons of bituminous and lignite. The National Coal Association estimated 776 million tons and EIA 771 million tons (including anthracite).

The EIA is anticipating substantially more generation of electric power by coal, showing an increase in consumption by utilities of 22.0 million tons or 4.1 percent between 1979 and 1980.

In general, the forecasts selected for comparisons vary surprisingly little with only one forecast (Pace) considerably higher than the others on most items covered. On specific items, motor gasoline and residual fuel oil show very wide variations among petroleum products, and the high and low estimates of coal production vary by more than 12 percent.

## 4. Midterm Energy Supply and Demand: 1985-1995

### OVERVIEW

The rapidly increasing price of imported oil is the most significant influence on the midterm energy outlook. The forecasts presented in this chapter reflect revisions in energy price expectations that followed the OPEC oil price increases of 1979. The impact of the price increases are felt throughout the energy markets in a number of ways. Compared to stable prices, rising prices lower oil consumption and raise domestic oil production, causing oil imports to decline. Because reduced oil consumption is only partially offset by the substitution of other fuels for oil, rising oil prices reduce total energy consumption.

In some sectors, the decreased demand for oil is striking. In the industrial sector, where decisions are largely based on cost factors, there is a rapid shift from oil to alternative fuels, particularly coal, consumption of which more than doubles by 1990. For example, new industrial boilers, which can produce steam using either oil, coal, or gas, invariably choose coal or gas. Existing oil-fired industrial boilers either convert to coal or gas or are retired before the end of their physical life. In the electric utility sector, existing oil-fired generating plants are retired and replaced by coal and nuclear plants as quickly as noneconomic factors, such as the approval of public utility commissions, will permit. In the transportation sector, which depends almost exclusively on petroleum products, energy demand actually declines during part of the forecast period, due to the use of more efficient vehicles and reduced growth in automobile travel.

The residential and commercial sectors, however, show less response to high oil prices, because these sectors depend less heavily on oil than the transportation sector and have less fuel switching capability than the industrial sector. To the extent that fuel switching occurs in these sectors, natural gas (which is subsidized to residential and commercial customers) and electricity gradually substitute for oil.

On the supply side, the high price of oil encourages high levels of exploratory drilling in the United States. New oil discoveries on the Outer Continental Shelf and Alaska contribute a growing proportion of total oil production during the midterm. However, as the domestic resource base is depleted and exploration shifts to frontier areas, exploration costs rise and finding rates decline. Domestic production declines initially and remains at or below current levels. Similar trends occur in natural gas production. North Alaska gas production begins shortly after 1985 and reaches maximum pipeline capacity by 1990.

The increased demand for coal requires significant expansion of coal production, especially in the West. Coal production in the Eastern States also increases. Production of synthetic fuels such as coal liquids and coal gases becomes economically viable with higher oil prices, as do certain enhanced oil and gas recovery technologies.

The high price of oil is not the only driving force behind these forecasts. Several recent laws complement the effects of high oil prices and contribute to the trends toward higher domestic energy production and lower energy demand. This legislation includes the Natural Gas Policy Act (NGPA), the Powerplant and Industrial Fuel Use Act (PIFUA), conservation programs, and new technology subsidies. Some parts of this legislation stimulate domestic production, whereas others reduce demand and influence fuel choice.

On the supply side, the NGPA phases out most price controls on natural gas at the wellhead and thus stimulates domestic production through higher prices to producers. In addition, subsidies for new technologies stimulate the development of new sources of domestic fuels to replace foreign oil.

On the demand side, PIFUA forces industrial plants and, to a lesser extent, electric utility plants to substitute coal for oil and natural gas. Conservation programs such as the Building Energy Performance Standards (BEPS) and the Auto Efficiency Standards mandate improved energy

efficiency. However, at the forecast oil prices, which are higher than those projected at the time the programs were enacted, some of these programs, such as auto efficiency standards, achieve little more than would otherwise have occurred in response to the high prices.

Recent turbulence in the energy markets has created more uncertainty for consumers and investors about future energy prices and availability. Thus, energy consumers are willing to pay premiums for fuels for which supplies are relatively certain and to invest in facilities that will be capable of switching between alternative fuels as necessary. For example, companies are likely to build boilers that switch easily between oil and gas use and modify some boilers to handle additional fuels.

### The Forecast Period

The midterm forecast covers the decade 1985 to 1995. This time period allows U.S. energy producers and consumers to make substantial adjustments to the world oil price increases of 1973 and 1979. For example, consumers can obtain new equipment that uses less expensive fuels or uses fuel more efficiently. Such options are limited in the short term, when consumers have little choice but to pay higher prices or do with less, but they have a major impact on fuel demand in the midterm.

Similarly, energy producers are limited in their capacity to respond immediately to higher prices. Over the midterm, however, supply can expand as the result of additional resource exploration and emerging energy technologies, both of which are stimulated by the higher prices. At the same time, however, the midterm is short enough to exclude any significant impact on energy production by technologies not already under development.

Finally, existing energy legislation can cause significant changes in energy markets in the midterm that could not be achieved in a shorter period. For example, automobile efficiency standards could reduce energy consumption in the midterm, but in a shorter period, only such legislative remedies as gasoline rationing would be effective.

### The Forecast

The remainder of this chapter describes the midterm forecast in greater detail. The Nation's energy system consists of four major areas of

energy consumption (industrial, residential, commercial, and transportation) as well as activities which convert primary fuels into energy forms usable by consumers (i.e., electric utilities and oil refineries). It also includes activities which produce primary fuels (coal, oil, and natural gas). In addition, a variety of transportation modes link the entire system. The remainder of this chapter discusses the forecasts for each of these facets of the energy system and then discusses the impacts that the energy situation will have on the economic system at large. The narrative continues with a comparison of the present forecast with previous EIA forecasts and those made by other organizations. This chapter concludes with a discussion of the sensitivity of the forecasts to various underlying assumptions.

The analysis presents three forecasts differing only in their assumptions about the oil import price. These three oil price paths are presented below in two ways. The first is in real, or inflation-adjusted, dollars as of mid-1979. The second is in nominal dollars. The final line shows the implicit price deflators used to convert mid-1979 dollars to nominal dollars.

#### Oil Prices

Scenario	Oil Prices in Mid-1979 Dollars						
	1965	1973	1978	1979	1985	1990	1995
Low Price	—	—	—	—	27.00	27.00	27.00
Medium Price	6.00	6.50	15.50	28.90	32.00	37.00	41.00
High Price	—	—	—	—	39.00	44.00	56.00
	Oil Prices in Nominal Dollars						
Low Price	—	—	—	—	43.15	59.35	77.22
Medium Price	2.25	4.15	14.77	31.37	51.14	81.33	117.26
High Price	—	—	—	—	62.32	96.71	160.16
	Implicit Price Deflator (Mid-1979 = 1.0)						
Deflator	0.45	0.64	0.95	1.09	1.60	2.20	2.86

The remainder of this section outlines broad conclusions based on the midprice projection and a brief comparison among the three price scenarios. In general, the broad conclusions made about the midprice projection also apply to the high and low cases; the rates at which changes will occur differ, however.

Throughout the analysis, comparisons are made with two representative years—1965 and 1973—and to the last year for which definitive historical data are available—1978. Tables 4.1 and 4.2 summarize from the forecasts discussed in detail in this section.

**Table 4.1 U.S. Energy Supply/Demand Balance: History and Projections for Three Base Scenarios, 1965–1995**  
(Quadrillion Btu per Year)

	History <sup>a</sup>			Projections								
	1965	1973	1978	1985			1990			1995		
				Low	Mid	High	Low	Mid	High	Low	Mid	High
World Oil Price (1979 dollars per barrel)	6.00	6.50	15.50	27.00	32.00	39.00	27.00	37.00	44.00	27.00	41.00	56.00
<b>Domestic Energy Supply</b>												
Oil .....	18.4	22.1	20.7	18.5	18.7	19.0	18.1	19.6	20.3	16.5	19.4	21.0
Gas .....	15.8	22.2	19.5	18.1	18.2	18.2	18.3	18.7	18.7	17.0	17.8	18.1
Coal .....	13.4	14.4	15.0	24.9	25.0	24.9	28.5	29.3	29.5	34.3	36.7	36.8
Nuclear .....	<sup>b</sup>	0.9	3.0	5.6	5.6	5.6	8.1	8.2	8.1	9.6	9.6	9.6
Other .....	2.1	2.9	3.0	3.4	3.4	3.4	3.7	3.7	3.7	4.1	4.1	4.1
Subtotal, Domestic Production .....	49.7	62.4	61.2	70.6	70.9	71.1	76.7	79.4	80.3	81.5	87.6	89.5
Net Oil Imports .....	5.0	13.0	17.1	14.2	12.1	11.0	17.0	11.7	9.5	21.2	11.8	7.7
Net Gas Imports .....	0.5	1.0	0.9	0.8	0.8	0.8	1.8	0.8	0.8	2.5	0.8	0.8
Net Coal Imports .....	-1.4	-1.4	-0.9	-2.2	-2.2	-2.2	-2.8	-2.7	-2.7	-3.6	-3.6	-3.6
Subtotal, Net Imports <sup>c</sup> .....	4.1	12.6	17.2	12.8	10.7	9.6	16.0	9.7	7.6	20.1	9.0	4.9
<b>Total Supply .....</b>	<b>53.8</b>	<b>75.0</b>	<b>78.4</b>	<b>83.4</b>	<b>81.6</b>	<b>80.7</b>	<b>92.7</b>	<b>89.1</b>	<b>87.9</b>	<b>101.6</b>	<b>96.5</b>	<b>94.4</b>
<b>Energy Demand<sup>d</sup></b>												
Refined Petroleum Products ...	22.5	31.2	34.2	31.0	29.4	28.7	32.8	29.9	28.7	36.0	31.3	29.1
Natural Gas .....	13.4	18.8	16.7	16.6	16.2	16.1	17.7	16.8	16.7	18.3	17.3	17.4
Coal .....	6.1	4.6	3.7	6.8	6.9	6.9	7.4	7.6	7.6	7.9	8.2	7.7
Electricity .....	3.3	5.8	6.8	8.3	8.3	8.3	10.0	10.0	10.0	11.4	11.6	11.7
Total End-Use Consumption ...	45.2	60.4	61.4	62.7	60.9	60.0	67.9	64.3	63.0	73.7	68.3	65.9
Conversion Losses <sup>e</sup> .....	7.8	14.1	16.6	20.7	20.7	20.7	24.8	24.8	24.9	27.9	28.2	28.5
<b>Total Consumption .....</b>	<b>53.0</b>	<b>74.5</b>	<b>78.0</b>	<b>83.4</b>	<b>81.6</b>	<b>80.7</b>	<b>92.7</b>	<b>89.1</b>	<b>87.9</b>	<b>101.6</b>	<b>96.5</b>	<b>94.4</b>

<sup>a</sup>Source for historical data is Volume 2 of the EIA *Annual Report to Congress, 1979*.

<sup>b</sup>Less than .05 quadrillion Btu.

<sup>c</sup>Includes .05 quadrillion Btu of electricity imports in 1973 and .07 quadrillion Btu in 1978. Includes imports for the Strategic Petroleum Reserve which began in 1977.

<sup>d</sup>Includes refinery consumption of refined petroleum products and natural gas.

<sup>e</sup>Includes losses or gains from electricity generation, synthetics production, and petroleum refining.

Until the mid-1960's the energy efficiency in the U.S. economy increased during periods of both rising and falling real energy prices. This increase occurred despite rising automobile use and declining automobile fuel efficiency. Increases in the energy efficiency of the industrial sector and shifts in the composition of U.S. output away from very energy-intensive products, such as iron and steel, compensated for these trends.

The sharp rise in real energy prices that followed the OPEC oil price increase of 1973 accelerated this trend in increased energy efficiency. The energy intensity of GNP declined at an average annual rate of 1.66 percent between 1973 and 1978. The decline continues at a faster rate through the midterm. Higher energy prices cause less energy-intensive production and consumption, as shown by the range of 1995 energy/GNP forecasts of 27.0 to 27.6 thousand Btu per 1979 dollar.

Net energy consumption (the energy used by the end-user) grew 4.3 percent annually between

1965 and 1973. Consumption of gross energy, or energy used to produce the final form of energy, followed a similar pattern. After the 1973–1974 increases in world oil prices, the growth in total energy consumption slowed to 0.8 percent yearly until 1978. Despite higher prices and slower growth in energy consumption, however, U.S. dependence on oil imports has continued to grow. Net imports accounted for 7.6 percent of total supply in 1965, 16.8 percent in 1973, and 21.9 percent in 1978. (See Figure 4.1.)

The trend of an increasing dependence on imports reverses in the midprice forecast, which assumes moderate increases in the real price of oil from present levels. The midprice case shows a growing proportion of the total U.S. energy supply flowing from domestic sources, as a rapid shift from oil and gas toward coal and nuclear power takes place. Domestic coal production increases 67 percent by 1985 and doubles (to 29.3 quadrillion Btu) by 1990, whereas nuclear power rises from 3 quadrillion Btu in 1978 to 8.2 quadrillion Btu in



**Table 4.2 U.S. Energy Prices: History and Projections for Three Base Scenarios 1965–1995**  
(1979 Dollars)

	History <sup>a</sup>			Projections								
	1965	1973	1978	1985			1990			1995		
				Low	Mid	High	Low	Mid	High	Low	Mid	High
<b>World Oil Price</b> (dollars per barrel)	6.00	6.50	15.50	27.00	32.00	39.00	27.00	37.00	44.00	27.00	41.00	56.00
<b>Supply Prices</b>												
Oil (dollars per barrel)												
Domestic (wellhead) .....	6.37	6.09	9.80	26.35	31.35	37.89	26.29	35.71	43.14	26.37	39.81	54.79
Imported-Landed U.S. ....	5.95	6.39	15.86	27.04	32.07	38.57	27.01	36.54	44.07	27.02	40.58	55.63
Average Refinery Acquisition Cost .....	—	6.48	13.57	26.95	31.96	38.49	26.89	36.40	43.88	26.96	40.55	55.60
Natural Gas (dollars per million Btu)												
Marginal Price Southwest <sup>b</sup> .....	0.35	0.34	2.19	2.68	2.68	2.68	3.43	3.68	3.40	3.91	4.04	3.86
Coal (mine entrance, dollars per ton)												
High-Sulfur Bituminous, Northern Appalachia .....	—	—	—	31.55	31.55	31.55	34.92	34.92	35.79	38.36	38.40	38.44
Low-Sulfur Subbituminous, Northwestern Great Plains .....	—	—	—	9.40	9.40	9.40	9.40	9.40	9.40	9.40	9.40	9.51
National Average <sup>c</sup> .....	9.88	13.34	23.70	28.35	28.35	28.35	31.05	30.60	30.82	31.95	31.05	31.05
<b>Demand Prices</b>												
Residential												
Electricity (cents per kilowatt-hour) .....	5.10	3.80	4.30	5.40	5.40	5.50	5.50	5.70	5.70	5.40	5.50	5.50
Distillate (dollars per gallon) .....	0.34	0.35	0.54	0.82	0.92	1.08	0.83	1.04	1.24	0.84	1.13	1.51
Natural Gas (dollars per million Btu) .....	2.27	1.98	2.68	3.86	3.83	3.81	4.86	4.65	4.40	5.47	5.06	4.68
Transportation												
Distillate (dollars per gallon) .....	0.32	0.33	0.50	0.95	1.05	1.20	0.96	1.17	1.36	0.97	1.26	1.63
Gasoline (dollars per gallon) .....	0.69	0.61	0.71	1.22	1.36	1.53	1.23	1.48	1.65	1.22	1.59	1.95
Jet Fuel (dollars per gallon) .....	0.26	0.23	0.48	0.86	0.96	1.12	0.87	1.08	1.31	0.88	1.18	1.59
Industrial												
Electricity (cents per kilowatt-hour) .....	2.20	2.00	2.90	3.80	3.90	3.90	4.10	4.20	4.20	4.00	4.10	4.10
Residual Fuel Oil (dollars per barrel) .....	7.80	10.81	15.65	29.23	34.55	40.85	29.54	39.13	46.68	30.10	42.92	58.28
Coal (dollars per ton) .....	23.18	22.05	30.15	47.02	47.18	47.18	50.30	50.86	51.40	52.51	53.09	52.88
Natural Gas (dollars per million Btu) .....	0.76	0.75	1.56	3.36	3.47	3.56	4.06	4.85	4.91	4.42	5.40	5.79
Industrial Surcharge (dollars per million Btu) .....	NA	NA	NA	0.51	0.63	0.73	0.27	1.09	1.34	0	1.18	1.90
Raw Materials												
Natural Gas (dollars per million Btu) .....	0.76	0.75	1.56	2.82	2.79	2.75	3.74	3.73	3.49	4.39	4.20	3.85
Average Price (dollars per million Btu)												
All Fuels/All Demand Sectors .....	3.17	3.11	4.36	6.74	7.18	7.76	7.11	8.01	8.56	7.31	8.52	9.64

<sup>a</sup>Source for historical supply data is Volume Two of the EIA *Annual Report to Congress*, 1979; the source for historical demand price data is the State Energy Data System (See note a, Table 4.3).

<sup>b</sup>Historical natural gas price for 1965 and 1973 is the average domestic wellhead price; the source for the 1978 price is the EIA *Monthly Energy Review*, September 1979.

<sup>c</sup>National average price for bituminous coal and lignite.

Note: — indicates that these data are not available.

NA indicates that these data are not applicable.

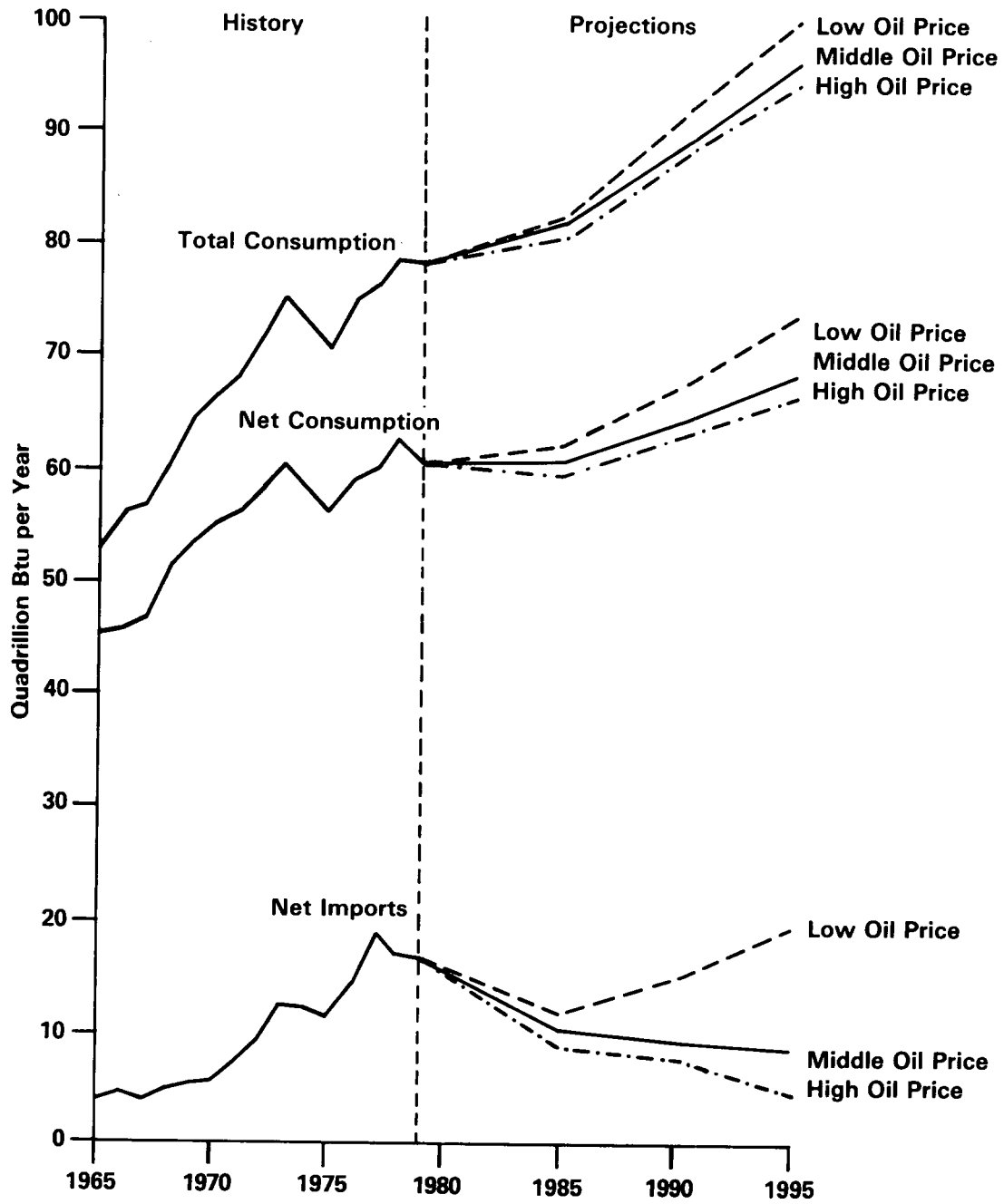

Figure 4.1 U.S. Energy Consumption and Imports

1990. Domestic production of oil and gas remains below historic levels; however, oil production increases slightly from 1985 to 1990 due to the development of onshore reserves in the Western States (including shale oil reserves).

Energy demand continues to grow slowly, averaging 0.7 percent annually between 1978 and 1985. After 1985, prices grow less quickly and demand growth returns to the postembargo rate of 1.7 percent annually between 1985 and 1995. Total consumption in 1990 is 89.1 quadrillion Btu, compared to 78.0 quadrillion Btu in 1978. The only end-use sectors that grow in the midterm are the industrial and utility sectors.

As a result of slower growth in energy demand and the rapid shift to coal and nuclear power caused by higher oil prices, net oil consumption drops from 34 quadrillion Btu in 1978 to only 29 quadrillion Btu in 1985 and remains almost constant thereafter. Eight percent of this decline is attributable to lower transportation demand and 92 percent to fuel switching in the other sectors. Thus, despite slowly decreasing domestic oil and gas production, the country shows increasing energy self-sufficiency. The ratio of oil imports to total domestic supply declines from 22 percent in 1978 to 15 percent in 1985, 13 percent in 1990, and 12 percent in 1995.

The average price of all fuels declined in real terms between 1965 and 1973 but rose, as a result of OPEC oil price increases, 40 percent between 1973 and 1978. (See Table 4.2.) In the midprice case, the average fuel price continues its postembargo 7 percent growth rate until 1985, when its growth rate slows to less than 2 percent yearly. This slowdown occurs because the world oil price grows more slowly, and because energy demand shifts to fuels that are less expensive. In fact, because of the shift to less expensive fuels, the average fuel price increases more slowly than the world oil price throughout the midterm. However, the 1995 average fuel price is almost double the 1978 price, even without incorporating the effects of inflation.

Due to deregulation, wellhead prices of domestic oil and gas increase faster than the prices of other fuels during the forecast period. Domestic gas prices increase rapidly between 1978 and 1985, as previously controlled prices reach free market levels. The average minemouth price of coal, which rose by more than 12 percent annually between 1973 and 1978 (as the coal industry adjusted to the environment and safety regulation of the 1970's),

grows by less than 2 percent yearly from 1978 to 1995.

Electricity prices exhibit the slowest price rise in the midterm and even decrease in real terms between 1990 and 1995. This decline occurs because lower capital investments by electric utilities during this period fail to offset the depreciation of the rate base on which electricity prices are calculated and because increasing amounts of less expensive coal and uranium are used to generate electricity.

Petroleum product prices rise faster than almost all other fuels. The exception is natural gas consumed by the industrial sector, which includes a surcharge related to the price of residual fuel oil. Gasoline prices rise by nearly 10 percent annually between 1978 and 1985, reaching \$1.36 per gallon in 1979 dollars in 1985. (This rate is equivalent to \$2.17 in 1985 dollars, assuming an inflation rate of 8.1 percent.)

Several results distinguish the forecasts under the three oil import price assumptions. First, high oil prices reduce the growth rate in energy demand from 1.6 percent annually between 1978 and 1995 in the low price case to 1.1 percent for the high price scenario. Second, the volume of net oil imports drops substantially between 1978 and 1985 in all three cases, but it rises again after 1985 (at a 4-percent annual rate) in the low case, while remaining constant or declining in the other two cases. Because there is little chance for capital stocks to respond to variations in oil prices before 1985, oil imports are almost the same for all scenarios in 1985. By 1995, however, declines in imports, induced by high oil prices, cause the annual cost of imported oil to be lower in the high case than in the low case. In the low case, the total expenditure for imported oil is \$82 billion; in the high case, it is \$58 billion. The effect on oil imports results from both the demand and the supply effects of the price assumptions. Constant real prices, in addition to stimulating energy demand, result in a much more rapid decline in domestic oil and gas production than do rising prices. Production in the low case is 86 percent of production in the high case in 1995.

Variations in the oil price assumption have a direct effect on the forecast prices of most other energy types, as shown in Table 4.2. The correlation between the world oil price and the retail prices of individual fuels is strongest for petroleum products in all sectors. For example, the forecast price of home heating oil in 1990 ranges from \$0.83

per gallon (1979 dollars) in the low case to \$1.24 in the high case. The projected price of gasoline in 1990 ranges from \$1.23 to \$1.65 per gallon.

The retail price of natural gas in the industrial sector is directly related to the price of oil, ranging from \$4.06 per million Btu in 1990 in the low case to \$4.85 in the midprice case and \$4.91 in the high case. These results are due to the incremental pricing provisions of the NGPA, which require industrial consumers to bear a major part of the burden of higher gas costs by paying a surcharge, which is limited by the price of fuel oil. (These projections assume that the surcharge is limited by the Btu-equivalent wholesale price of high-sulfur residual fuel oil.) The surcharge increases with the price of oil, thereby raising the price paid by industrial consumers.

The residential gas price follows the opposite pattern to the price in the industrial sector in 1990, ranging from \$4.86 in the low case to \$4.65 in the midprice case and \$4.40 in the high case. The price follows a similar pattern in 1995. This result is due to a combination of factors. First, the effects of incremental pricing to industrial consumers (via the surcharge) are stronger with higher oil prices. Thus, the subsidy to residential consumers is greater with higher oil prices. Second, the incremental pricing effects, as well as PIFUA regulations, work to reduce industrial consumption of natural gas as oil prices increase. This weakening of gas demand at high oil prices reduces the wellhead price of gas, which in turn reduces the residential price of gas. For example, in 1990, the wellhead price of gas is \$3.40 per million Btu in the high case and \$3.68 per million Btu in the middle case, while the residential price is \$4.40 per million Btu in the high case and \$4.65 per million Btu in the middle case.

Finally, electricity prices are not highly correlated with the price of oil. Electricity production in the forecast period relies more heavily on coal, which has relatively flat supply curves, and nuclear power, additions to which are insensitive to oil prices.

## ENERGY CONSUMPTION

The demand for energy is a derived demand, that is, consumers require energy not for energy alone but for its role in providing the goods and services they use. Examples of these goods and services include housing, transportation, and in-

dustrial products. Energy materials also provide goods and services when they are delivered in the form of products such as petrochemicals, synthetic fibers, and asphalt. Therefore, energy demand depends on the factors affecting the demand for services and industrial output. The major determinants of energy consumption considered in this analysis are population, gross national product (GNP) growth, and price.

Four distinct end-use sectors of the economy consume energy: industrial, residential, commercial, and transportation. (See Figure 4.2.) Because of their similarity, the residential and commercial sectors are grouped together in the discussion that follows. This section begins with a brief discussion of the macroeconomic forecasts on which the sectoral forecasts are based.

## Macroeconomic Forecast

The energy projections depend, in part, on macroeconomic forecasts for the U.S. economy which are variants of TRENDLONG2004 recently published by Data Resources Incorporated (DRI). The TRENDLONG2004 gross national product (GNP) continues to grow at about the post-1973 rate as shown in Figure 4.3. This forecast reflects a continued increase in labor force participation and a fairly strong outlook on capital formation. Real, fixed business investments as a share of real GNP rise from 10.0 percent in 1978 to 11.0 percent in 1990. Real Federal expenditures decline as a share of real GNP, dropping from 21.4 percent in 1978 to 20.5 percent in 1995. Monetary expansion (demand and time deposits) proceeds at a compound annual rate of 7.1 percent from 1978 to 1990, which is a lower rate than in the immediate past.

Values for macroeconomic variables, identified with each projection series, reflect the interactions of energy and economy. For example, GNP growth rate varies from 2.7 percent annually in the low case, 2.6 percent in the middle case, and 2.4 percent in the high case (over 1978-1995), reflecting the adverse effect of higher oil prices on the overall economy.

The population forecast used in these projections is the Bureau of the Census' Series II. Because of the relatively small uncertainty about population forecasts during the 1978 to 1995 period, the population projections underlying the energy demand forecasts given here do not vary across projection series. During that period, the

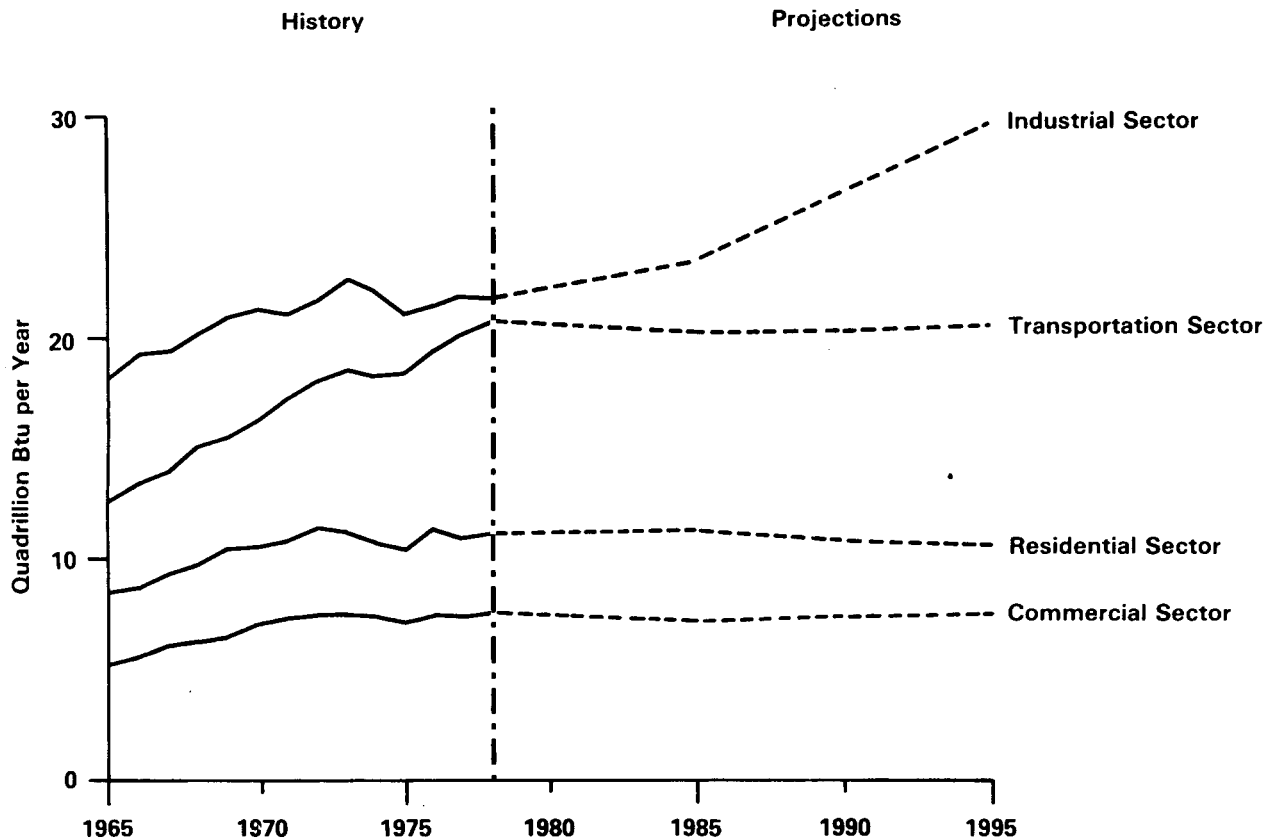

**Figure 4.2 Net Energy Consumption by Sector, 1965–1995: Middle World Oil Price**

U.S. population is assumed to grow at 0.8 percent annually, the same rate as between 1965 and 1978.

### Industrial Sector

The industrial sector is the largest consumer of energy in the economy, accounting for 36 percent of total domestic energy consumption in 1978. By 1990, in the midprice case, this share increases to 42 percent. The size of the sector is not the sole reason it plays such a critical role in national energy policy. As a consumer of a wide variety of fuels, the industrial sector is a focal point for government policies designed to reduce the Nation's reliance on imported oil. The result of these policies and of higher oil prices on the industrial fuel mix is a striking reversal of historical trends.

Total energy consumption in the industrial sector is closely related to the level of industrial output. Fuel-consuming industrial equipment converts thermal energy to mechanical energy. Boilers, for example, convert fossil fuels to steam

which is then used with other resources (labor, capital, materials) to produce final products. Increased production levels normally require increased levels of all inputs, including energy. Manufacturing value added increases 3.6 percent annually between 1978 and 1990; accordingly, total industrial energy consumption also grows, although at the substantially slower rate of 1.7 percent annually.

The overall energy intensity of industrial activity (as measured by the number of Btu consumed per constant dollar of manufacturing value added) continues to decline in the forecast period, as shown in Figure 4.4. Between 1965 and 1973, energy consumption grew 2.9 percent annually, which was about 60 percent as rapidly as value added in manufacturing. In the post-OPEC embargo period, 1973–1978, this decline rate of energy intensity accelerated: total energy consumption actually declined and value added grew 2.0 percent annually.

The forecasted decrease in industrial energy intensity is similar to the trend during the post-

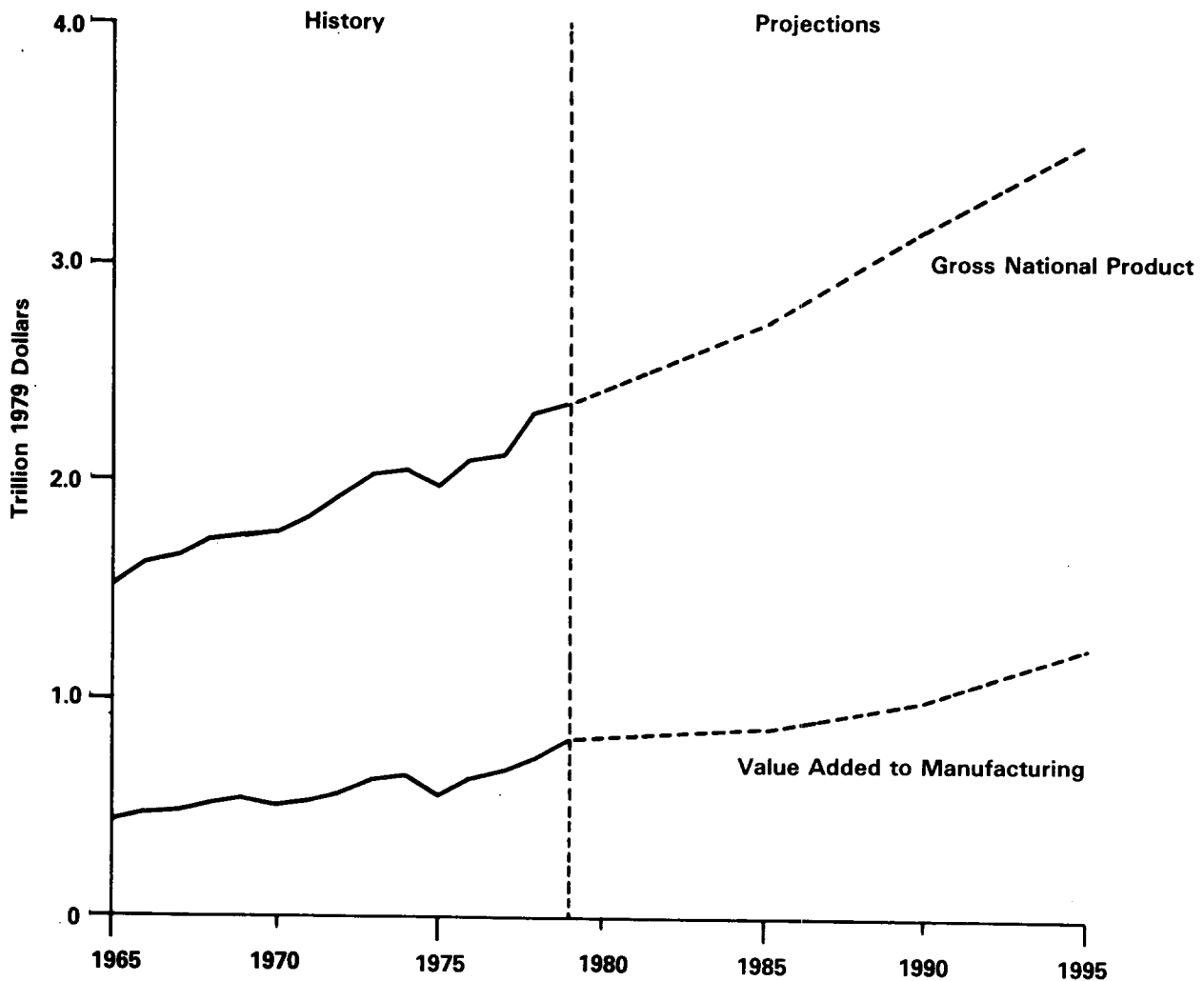

**Figure 4.3 U.S. Economic Activity in the Midterm: Middle World Oil Price**

OPEC embargo period. In the midprice case, net industrial energy consumption increases only 46 percent as rapidly as value added in manufacturing through 1990, implying that the energy intensity of industrial output declines about 2 percent annually.

Until the OPEC embargo and ensuing leap in world oil prices, the pattern of industrial energy use and industrial technology development had evolved during a time of ample supplies of oil, gas, and other fuels and generally stable real prices of energy. With low energy prices, process designs were more energy intensive than they would have been if sharply increasing real energy prices were widely anticipated.

Although these projections do not explicitly recognize energy savings from the changes in processes or the construction of more efficient

combusters, they are consistent with the theory that the reduction in energy use, which occurred in the industrial sector between 1973 and 1978, was largely of a housekeeping nature and that further energy savings must be achieved with substantial energy saving investments and process changes. Because such changes have not been systematically addressed, these forecasts are open to other interpretations.

The projected level of total industrial energy use depends only slightly on the world oil price. Higher world oil prices result in lower levels of economic growth, industrial output, and industrial energy consumption. In 1990, a 63-percent variation in world oil prices between the low and high scenarios leads to a 3.8 percent change in manufacturing value added and a 6.3 percent change in total consumption of industrial energy.

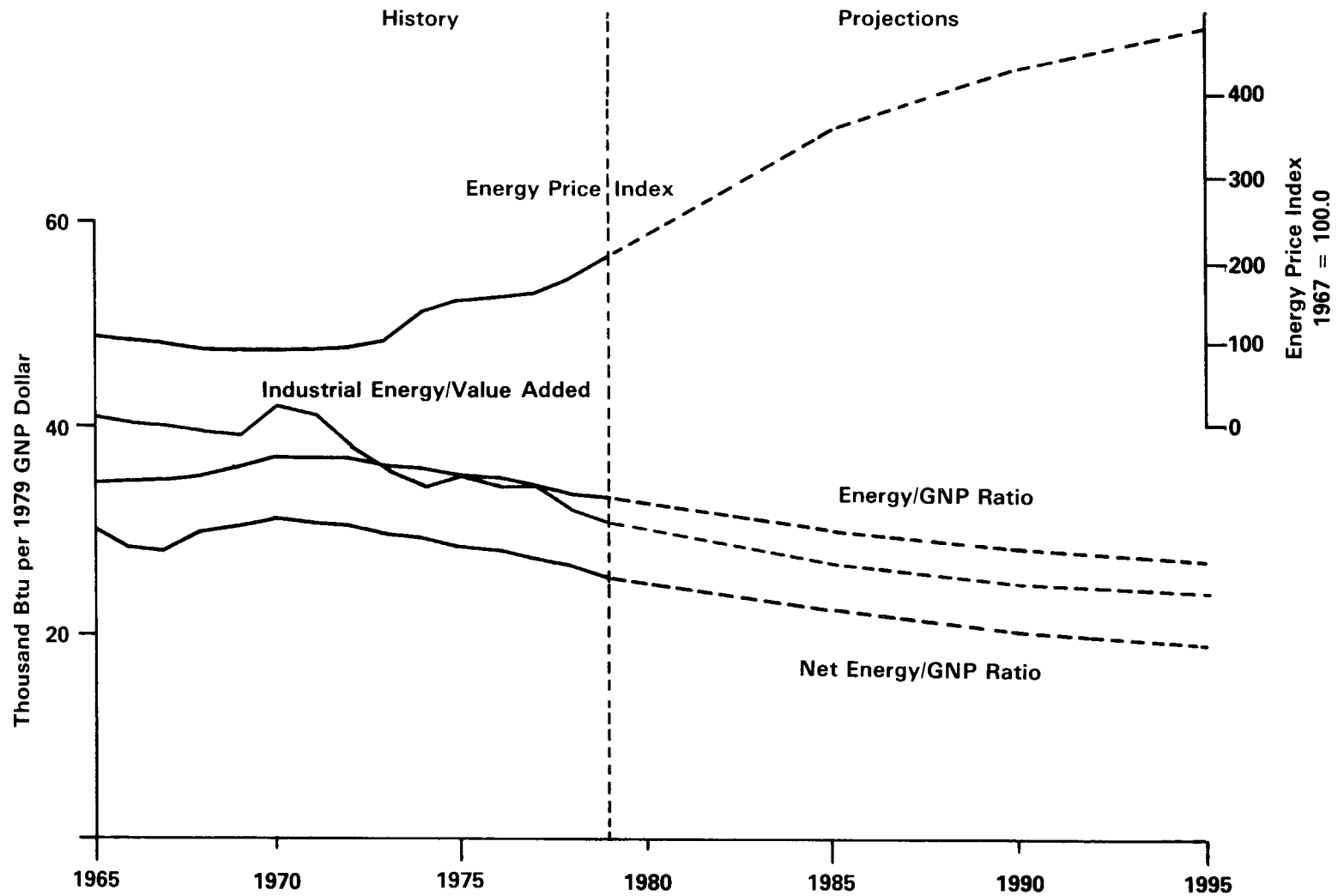

Figure 4.4 U.S. Energy-Economic Indicators in the Midterm: Middle World Oil Price

The industrial fuel mix in the midterm, as shown in Figure 4.5 and Tables 4.3 and 4.4, differs markedly from recent experience. Oil consumption declines over 20 percent annually through 1985. Recent legislation, described below, coupled with increases in the world oil price cause this shift. Residual oil prices to the industrial sector more than double between 1978 and 1985 in both the medium and high price cases. However, this analysis assumes the industrial sector responds promptly to these economic and regulatory pressures and does not reflect constraints on the availability of coal-fired equipment or uncertainty about environmental regulations.

Coal is currently the least expensive fossil fuel. In 1978, its price in energy equivalent terms was about 14 percent below that of natural gas and 46 percent below the price of residual oil. This fuel price advantage increases dramatically over the forecast period. By 1990, the national average price of coal delivered to the industrial sector is less than half the price of natural gas and an even smaller fraction of the projected price of residual oil. However, the capital costs associated with transporting and burning coal in an environmentally acceptable manner are high. A complete coal-fired boiler system, for example, can cost three to four times as much as a comparable gas-fired system. The required pollution control equipment alone can cost more than the total cost of the gas-fired unit. Nonetheless, in most settings, where coal is feasible, coal systems have the lowest life-cycle costs.

Several provisions of the National Energy Act of 1978 are designed to improve the competitiveness of coal through reducing its capital cost and increasing its fuel price advantage relative to other fossil fuel alternatives. In particular:

- The Natural Gas Policy Act of 1978 increases the price of natural gas to most industrial customers.
- The Powerplant and Industrial Fuel Use Act of 1978 prohibits the use of oil and gas in new boilers with a firing rate of 100 million Btu per hour or greater. Exemptions from this requirement can be granted for reasons of cost, environmental impact, or site restrictions.

The industrial fuel mix projections depend on a comparison of life cycle costs of equipment burning alternative fossil fuels: distillate fuel oil,

high- and low-sulfur residual fuel oil, natural gas, and various sulfur levels of coal. Several caveats must be observed in interpreting these results.

- The analysis assumes that capital is available to invest in energy cost-reducing projects. This assumption may be unrealistic in view of current business practices, under which energy investments are evaluated with respect to a wider variety of investment alternatives than have been considered here.
- The analysis assumes that the supply of coal boilers and coal-handling equipment is sufficient to permit the rapid switch from oil and gas to coal that is forecast.
- Conventional coal use is the single "alternative fuel" considered. As such, it increasingly represents a proxy for the penetration of all nonconventional technologies in the latter years of the projection period.

In 1978, distillate and residual fuel oil provided nearly 12 percent of the total energy consumed by industry. By 1985, it accounts for no more than 2 percent of industrial fuel use in all of the scenarios. This declining reliance on oil is the most outstanding feature of the current industrial forecasts.

In contrast, industrial coal consumption, which declined over the last few decades, increases significantly in the midterm, more than offsetting the decline in oil consumption. By 1990, coal accounts for nearly 27 percent of industrial energy, compared to 15 percent in 1978. Most of this projected increase in coal consumption is in conventional boilers, where coal use is not limited by technical problems. The remainder of the increase is in process heat applications.

Natural gas use in process heaters and boilers declines between 1978 and 1985 and increases slightly thereafter. The earlier decline corresponds to a decrease in natural gas use as a boiler fuel. Beyond 1985, increases in the process heat use of natural gas outweigh this decline; by 1990 natural gas use is almost at the 1978 level, although its market share declines. By 1985, it accounts for less than 31 percent of industrial energy requirements, compared to 36 percent in 1978. The raw material and feedstock use of natural gas increases throughout the midterm.

Electricity use increases significantly during the forecast period, accounting for 19 percent of the industrial market by 1995 in the middle series,



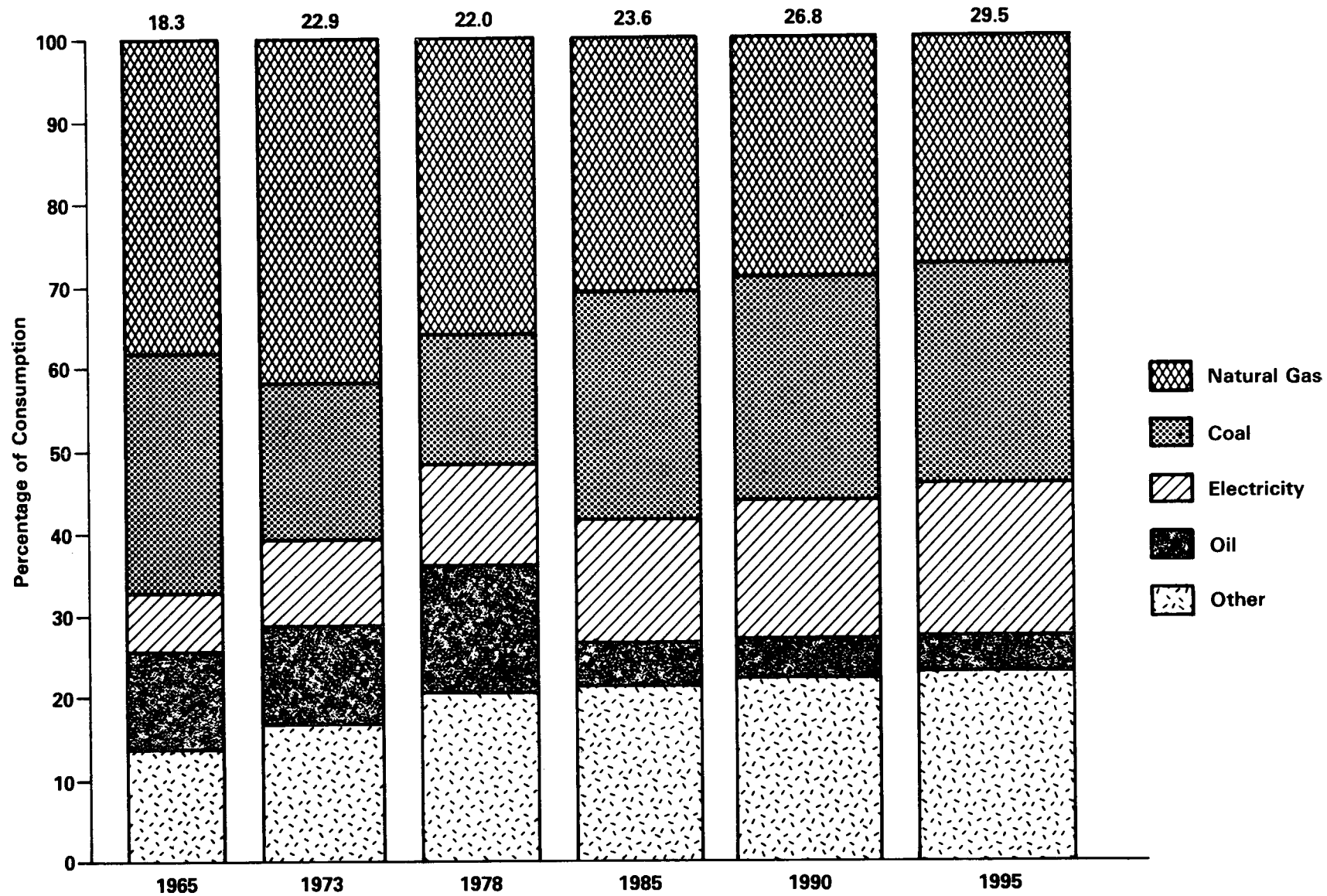

**Figure 4.5 Industrial Energy Fuel Shares by Source: Middle World Oil Price, 1965–1995**

**Table 4.3 Industrial Energy Consumption and Prices: History and Projections for Three Base Scenarios, 1965-1995**  
(Quadrillion Btu and 1979 Dollars per Million Btu)

Fuel	History <sup>a</sup>			Projections								
	1965	1973	1978	1985			1990			1995		
				Low	Mid	High	Low	Mid	High	Low	Mid	High
Electricity.....	1.50	2.30	2.70	3.60	3.60	3.60	4.50	4.60	4.60	5.30	5.50	5.60
Price.....	6.41	5.96	8.34	11.27	11.32	11.48	11.88	12.18	12.26	11.76	11.96	12.00
Distillate <sup>b</sup> .....	0.70	0.90	1.20	0.30	0.30	0.30	0.40	0.40	0.40	0.50	0.40	0.40
Price.....	2.29	2.33	3.60	5.62	6.34	7.46	5.66	7.18	8.62	5.76	7.85	10.55
Residual <sup>b</sup> .....	1.20	1.30	1.50	0.20	0.10	0.10	0.20	0.10	0.10	0.50	0.20	0.10
Price.....	1.24	1.72	2.49	4.65	5.49	6.50	4.70	6.22	7.42	4.79	6.83	9.27
Liquid Gas.....	0.30	0.60	0.80	0.70	0.70	0.60	0.80	0.70	0.60	0.90	0.80	0.60
Price.....	1.90	2.37	3.42	6.71	7.45	9.56	6.71	8.83	10.80	6.71	9.56	13.30
Coal.....	5.40	4.40	3.40	6.50	6.50	6.50	7.10	7.30	7.20	7.70	7.90	7.40
Price.....	1.03	0.98	1.34	2.09	2.10	2.10	2.24	2.26	2.28	2.33	2.36	2.35
Natural Gas <sup>b</sup> .....	6.80	9.60	7.90	7.60	7.20	7.10	8.70	7.80	7.50	9.30	8.10	8.00
Price.....	0.76	0.75	1.56	3.36	3.47	3.56	4.06	4.85	4.91	4.42	5.40	5.79
Other <sup>c</sup> .....	2.50	3.80	4.50	5.20	5.10	5.10	6.20	6.00	5.90	7.10	6.70	6.50
Total Consumption.....	18.30	22.90	22.00	24.00	23.60	23.30	28.00	26.80	26.30	31.30	29.50	28.70
Average Price.....	1.61	1.73	2.98	4.86	4.97	5.13	5.40	5.90	5.97	5.71	6.26	6.64

<sup>a</sup>Sources of historical data are (1) *State Energy Fuel Prices by Major Economic Sector 1960 to 1977, Preliminary Report and Documentation*, July 1979, DOE/EIA-0190 and (2) *State Energy Data Report, Statistical Tables and Technical Documentation 1960-1978*, DOE/EIA -214(78).

<sup>b</sup>Includes refinery consumption, excluding raw materials.

<sup>c</sup>Include feedstocks, raw materials, and refinery consumption of still gas and oil.

Note: The analysis of industrial energy consumption treated the following four components separately: process heaters and small boilers, major boilers, refineries and raw materials. The text discusses some of the different trends in these areas.

compared to 12 percent in 1978. Over this period, the price of electricity increases at an average rate of only 2.1 percent, compared to the weighted average price increase for all industrial fuels of 4.5 percent.

Finally, although the overall fuel mix excluding raw materials and feedstocks in the industrial sector is sensitive to changes in the world oil price, due to the substitutability of gas for oil in process heaters, the fuel mix for industrial boilers alone is not. Because of high distillate and residual oil prices (even in the low scenario), it is far more economical to burn gas or coal in industrial boilers. The Powerplant and Industrial Fuel Use Act restricts the use of gas in boilers with capacities greater than 100 million Btu per hour, making coal the primary boiler fuel.

## Transportation Sector

The transportation sector uses energy to move people or commodities by five modes of travel:

highway, air, rail, marine, and pipeline. In 1978, the transportation sector consumed one-third of the net energy and 53 percent of all the petroleum used in the United States. Petroleum represents over 97 percent of this sector's energy requirements. Thus, as the single largest consumer of petroleum, the U.S. transportation system is highly vulnerable to fluctuations in oil prices and petroleum supply uncertainties.

The most notable feature of the current transportation forecasts is the decline in the projected level of transportation energy consumption through 1985, shown in Table 4.5. Thereafter, transportation energy use increases slowly, approaching the 1978 level by 1995. This sector's share of total domestic consumption of energy follows a similar pattern, reversing the trend begun in 1965, when transportation energy use started growing at a higher rate than total energy use. By 1985, transportation's share of total net energy declines to the 1973 level of 32 percent and then remains near that share until 1995.

**Table 4.4 Industrial Energy Consumption and Prices: Compound Annual Growth Rates, Projections for Mid-World Oil Price Scenario, 1965-1995 (Percent)**

Fuel	History <sup>a</sup>		Projections			
	1965-1973	1973-1978	1978-1995	1978-1985	1985-1990	1990-1995
Electricity	6.1	3.1	4.2	4.0	4.9	3.8
Price	-0.9	7.0	2.1	4.5	1.5	-0.4
Distillate	3.7	5.1	-6.2	-16.2	1.6	1.5
Price	0.3	9.1	4.7	8.4	2.5	1.8
Residual	1.4	1.8	-11.9	-29.8	3.3	3.2
Price	4.1	7.7	6.1	12.0	2.5	1.9
Liquid Gas	9.3	5.7	-0.2	-2.5	1.5	1.6
Price	2.8	7.6	6.2	11.8	3.5	1.6
Coal	-2.6	-4.7	5.1	9.7	2.1	1.8
Price	-0.7	6.6	3.4	6.6	1.5	0.9
Natural Gas	4.4	-3.8	0.1	-1.3	1.5	0.7
Price	-0.2	15.8	7.6	12.1	6.9	2.2
Other	5.1	3.3	2.4	1.9	3.1	2.4
Total Consumption	2.9	-0.9	1.8	1.0	2.6	2.0
Average Price	0.9	11.5	4.5	7.6	3.2	1.5

<sup>a</sup>Sources of historical data are (1) *State Energy Fuel Prices by Major Economic Sector 1960 to 1977*, Preliminary Report and Documentation July 1979, DOE/EIA-0190, and (2) *State Energy Data Report*, Statistical Tables and Technical Documentation 1960-1978, DOE/EIA-214(78).

Note: The analysis of industrial energy consumption treated the following four components separately: process heaters and small boilers, major boilers, refineries and raw materials. The text discusses some of the different trends in these areas.

The transportation sector continues to be petroleum-dependent for 97 percent of its energy requirements throughout the projection period. (See Figure 4.6.) Petroleum use becomes more efficient however, due to higher fuel prices, which increase the demand for more fuel efficient new cars. A significant shift from gasoline to more efficient diesel engines enhances this efficiency improvement. In addition, higher fuel prices slow the growth of demand for transportation services.

#### Determinants of Transportation Energy Use

The majority of transportation energy is used in highway travel, as shown in the table below, with the greatest proportion in passenger cars. Air travel accounts for 10 percent of transportation

energy consumption, and trucks, which dominate freight transport, account for 25 percent.

#### Proportion of Transportation Energy Use by Mode of Travel in 1978

Travel Mode	Percent
Highway	
Passenger Car and Motorcycle	50.2
Bus	0.6
Truck	24.9
Nonhighway	
Rail	2.9
Air	10.3
Marine (U.S. purchased)	6.1
Pipeline	2.6
Other	2.4
Total	100.0

The demand for commercial transportation is heavily dependent on GNP, industrial production, and market location, whereas personal transportation energy use, which dominates the sector, is influenced more by the level of personal disposable income and population. The projected growth rates of these economic variables are lower than historical growth rates, as discussed previously. Energy prices and policies are also important determinants of both personal and commercial transportation activity. All these determinants affect transportation energy demand through the average efficiency of existing vehicles and the number of vehicle-miles traveled (VMT).

Although federally mandated, fuel-efficiency standards for automobiles are assumed to be in effect, higher fuel prices increase the demand for cars whose efficiency is even higher than the mandated standards. For example, the average new-car mileage expected by meeting the standards in 1985 is approximately 21.7 mpg, whereas the projection indicates that the average new car efficiency is 22.4 mpg. As more efficient, new cars are purchased and older, less efficient ones are scrapped, the average fleet efficiency improves. This trend to higher vehicle efficiency is reinforced by a switch to diesel-powered vehicles, which are assumed to account for 10 percent of the new auto and light-duty truck vehicles by 1985. Diesel-pow-

**Table 4.5 Transportation Energy Consumption and Prices: History and Projections for Three Base Scenarios, 1965–1995**  
(Quadrillion Btu and 1979 Dollars per Million Btu)

	History <sup>a</sup>			Projections									
	1965	1973	1978	1985			1990			1995			
				Low	Mid	High	Low	Mid	High	Low	Mid	High	
<b>Fuel</b>													
Distillate Price.....	1.10 2.28	2.10 2.34	2.60 3.61	3.30 6.85	3.10 7.56	3.00 8.68	4.10 6.89	3.80 8.41	3.50 9.84	4.70 6.99	4.20 9.08	3.70 11.77	
Gasoline <sup>b</sup> Price.....	9.20 5.53	13.10 4.89	14.50 5.64	12.50 9.78	12.00 10.90	11.40 12.21	12.60 9.82	11.40 11.86	10.70 13.17	13.80 9.78	11.80 12.76	10.70 15.59	
Jet Fuel Price.....	1.20 1.91	2.10 1.74	2.20 3.60	2.40 6.47	2.30 7.23	2.10 8.42	2.80 6.54	2.50 8.12	2.20 9.87	3.30 6.62	2.70 8.89	2.20 11.98	
Other .....	1.30	1.50	1.70	1.70	1.70	1.70	1.70	1.70	1.70	1.60	1.70	1.70	
Total Consumption.....	12.80	18.90	20.90	19.90	19.10	18.30	21.10	19.40	18.10	23.40	20.40	18.30	
Average Price .....	4.62	4.08	4.94	8.50	9.54	10.69	8.43	10.33	11.62	8.43	11.12	13.80	

<sup>a</sup>Sources of historical data are (1) *State Energy Fuel Prices by Major Economic Sector 1960 to 1977*, Preliminary Report and Documentation, July 1979, DOE/EIA-0190 and (2) *State Energy Data Report*, Statistical Tables and Technical Documentation 1960-1978, DOE/EIA-214(78).  
<sup>b</sup>Includes industrial and commercial consumption of motor gasoline.

ered cars are estimated to be 50 percent more efficient than gasoline-powered automobiles.

The total fleet, average fuel efficiency is forecast to improve over time as follows:

**Average Fleet On-the-Road Efficiency  
(Miles per Gallon)**

Highway Vehicles	1978	1985	1990	1995
Automobiles	14.3	17.3	21.1	23.4
Light-Duty Trucks	11.7	13.8	15.0	15.5
Total Trucks	8.6	9.2	9.7	9.9
Buses	6.0	6.5	7.0	7.5

Source: *Federal Highway Statistics, 1978*, Table VM1, Federal Highway Administration

In the non-highway modes of travel, significant fuel-efficiency improvements for jet aircraft occur at an annual rate of almost 2 percent. Efficiency improvements are assumed to be negligible in the rail, marine, and pipeline modes.

Vehicle-miles traveled (VMT) responds to changes in fuel prices and income. Despite substantial increases in gasoline prices through 1985, the effect of higher incomes dominates and automobile travel continues to grow, although at a slower rate than in recent years. Between 1973 and 1978, both gasoline prices and automobile travel grew by almost 3 percent annually.

Between 1978 and 1985, a 9.9 percent annual growth rate in gasoline prices is associated with a 1.4 percent increase in automobile travel. After 1985, gasoline prices increase moderately at 1.6 percent annually, which largely contributes to the higher automobile VMT growth rate of 3.7 percent annually through 1995. Estimates of VMT by transportation component are as follows:

**Transportation Activity Estimates**

	Year			
	1978	1985	1990	1995
Automobiles and motorcycles (billion vehicle-miles)	1194	1317	1601	1892
Trucks (billion vehicle-miles)	348	311	340	366
Air (billion passenger-miles)	219	277	322	379

Source: *Federal Highway Statistics, 1978*, Table VM1, Federal Highway Administration

Truck VMT drops by 37 billion miles from 1978 to 1985, largely in the light-duty truck subcomponent, because fuel prices increase almost 10 percent yearly. Thereafter, more moderate price increases encourage the 1.6 percent annual growth of total truck VMT through 1995. Freight truck VMT grows directly with GNP and industrial production through the projection period, but it is tempered by the fuel price increases.

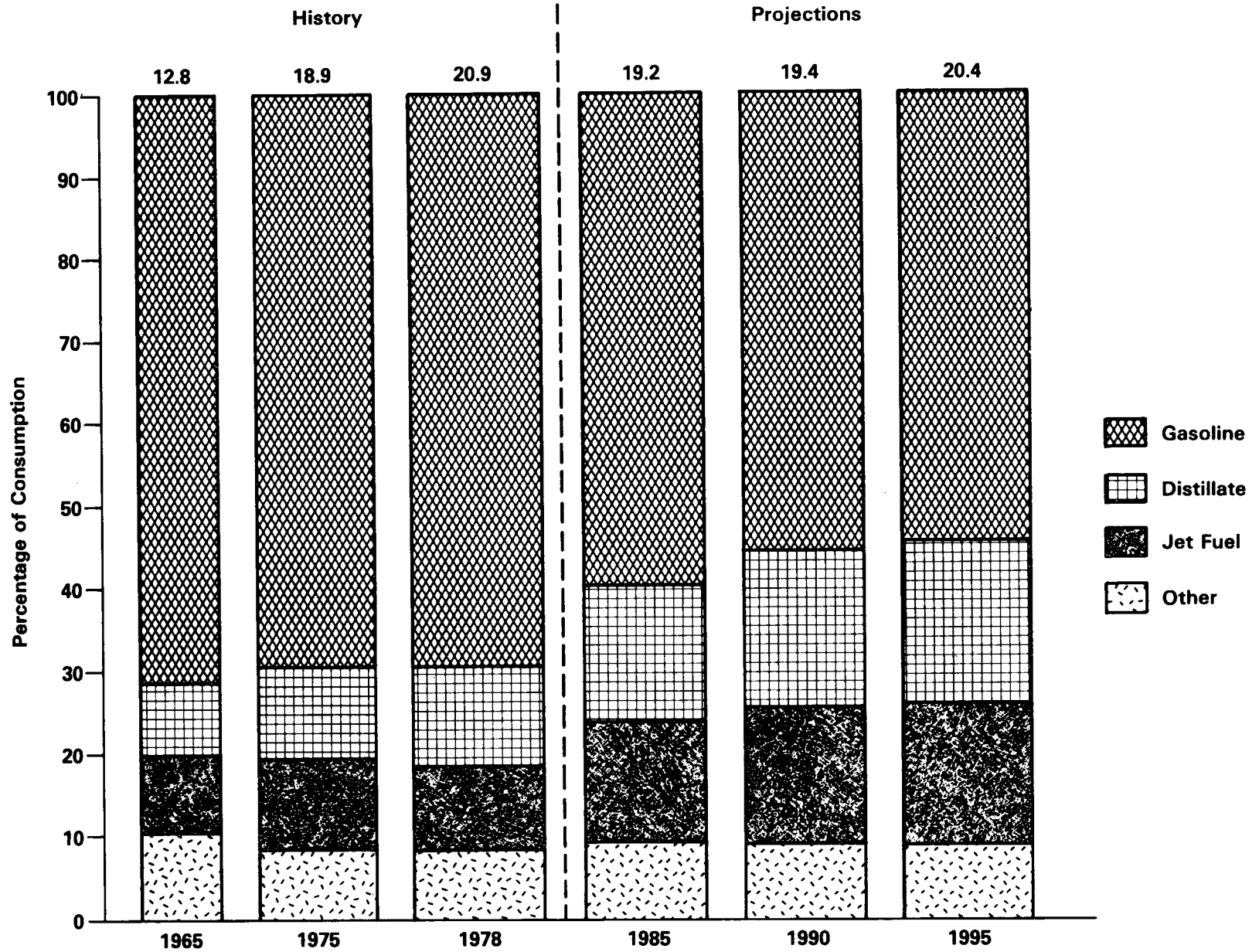

Figure 4.6 Transportation Energy Fuel Shares by Source: Middle World Oil Price, 1965–1995

Air passenger travel grows 3.3 percent annually between 1978 and 1995, primarily due to income growth. However, increasing jet fuel prices, which rise 10.5 percent yearly through 1985 and at a more moderate 2.1 percent thereafter, partially offset the income effect.

The potential for fuel substitution within a particular transportation mode is limited, given the stock of transport vehicles expected to be in use. Although increasing penetration of new diesel-fueled vehicles into the automobile and light-duty truck fleet continues to displace gasoline, new technologies such as electric and hydrogen-fueled vehicles do not penetrate the automobile market significantly during the the projection period. Gasohol is not distinguished from gasoline in the projections.

### Historical Perspective and Projected Trends

Changes in efficiency and transportation activity in the projections lead to dramatic departures from past trends in the sector's energy use. During the postembargo period, 1973-1978, when energy use declined or remained constant in all other sectors, transportation energy use continued to grow 2 percent annually. (See Table 4.6.) Between 1978 and 1985, however, transportation energy use

**Table 4.6 Transportation Energy Consumption and Prices: Compound Annual Growth Rates, Projections for Middle World Oil Price Scenario, 1965-1995**  
(Percent)

Fuel	History <sup>a</sup>		Projections			
	1965-1973	1973-1978	1978-1995	1978-1985	1985-1990	1990-1995
Distillate .....	8.7	4.2	2.9	2.7	3.8	2.2
Price.....	0.3	9.1	5.6	11.1	2.2	1.5
Gasoline .....	4.5	2.1	-1.2	-2.7	-1.0	0.7
Price.....	-1.5	2.9	4.9	9.9	1.7	1.5
Jet Fuel .....	7.4	<sup>b</sup>	1.4	0.9	1.7	1.8
Price.....	-1.1	15.6	5.5	10.5	2.4	1.8
Other .....	1.7	1.8	<sup>b</sup>	0.5	-0.2	-0.4
Total Consumption.	5.0	2.1	-0.1	-1.3	0.3	1.1
Average Price ...	-1.5	3.9	4.9	9.9	1.6	1.5

<sup>a</sup>Sources of historical data are (1) *State Energy Fuel Prices by Major Economic Sector 1960 to 1977, Preliminary Report and Documentation*, July 1979, DOE/EIA-0190 and (2) *State Energy Data Report, Statistical Tables and Technical Documentation 1960-1978*, DOE/EIA-214(78).

<sup>b</sup>Less than 0.05 percent.

declines more than any other sector. This reversal is primarily due to the dramatic 10-percent annual increase in fuel prices during the period, but it is also related to an assumed shift towards more efficient vehicles, including diesels.

The decreases in transportation energy use are almost entirely attributable to gasoline consumption, which dominates the sector's fuel use. Throughout the projection period, distillate and jet fuel consumption continue to grow, although at less than one-third of their preembargo (1965-73) rate. This increase occurs even though the price increases for distillate and jet fuel are slightly higher than those for gasoline. This difference in price response among the major transportation fuels is due to two factors. The first is the assumed shift into diesel-powered cars and light trucks, which increases distillate consumption and reduces gasoline use. The second is the nature of the use of different fuels. Gasoline is used more for personal transportation, which is more discretionary and has a greater range of efficiency options. These options, which may be partially a result of fuel-efficiency standards, make gasoline use more responsive to price changes. Distillate and jet fuel consumption are primarily used for freight movement and business travel, both of which are more rigidly tied to economic activity and are thus less responsive to price changes.

Between 1985 and 1990, the decline in gasoline use slows and is offset by increased growth of distillate and jet fuel, as shown in Figure 4.7. Thus, total transportation energy use increases slightly. This change is due to the decreased growth of the average fuel price to less than 2 percent annually in the middle case after 1985. After 1990, the consumption of major fuels by the transportation sector increases. By 1995, total transportation energy use returns almost to its 1978 level.

Average fuel prices for the transportation sector vary 32 percent in 1990. This variation causes a 14 percent variation in consumption. The low price case shows total transportation energy use exceeding its 1978 level in 1990, compared to the high price case which shows total consumption almost 10 percent below the 1978 level in 1995.

### Uncertainties

Two major uncertainties underlying these forecasts are the fuel efficiency of the new car fleet and the proportion of the vehicle fleet that is diesel-powered.

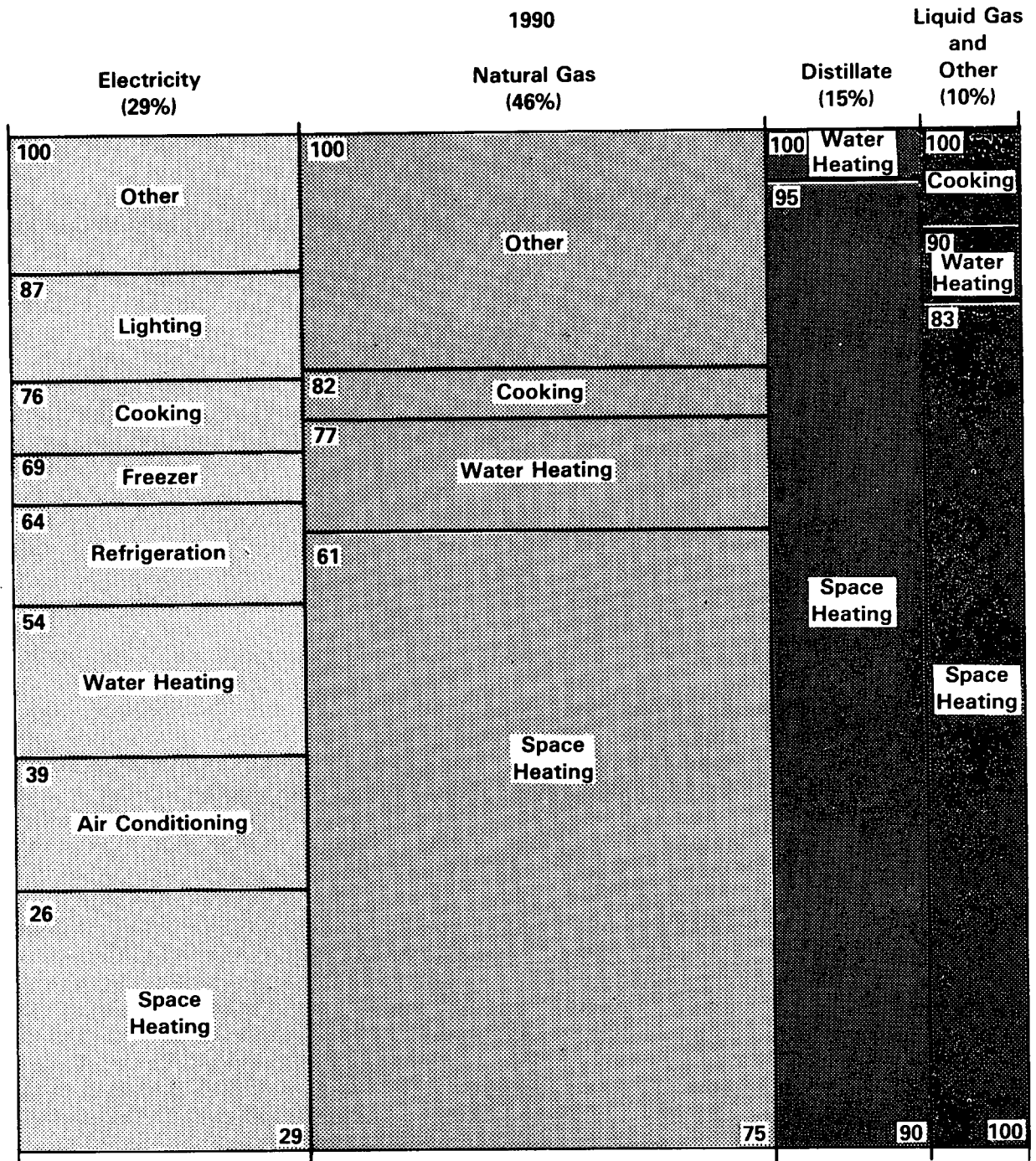

**Figure 4.7 Distribution of Net Energy by Fuel and End-Use in the Household Sector**

The results discussed above indicate that the consumer will react strongly to higher fuel prices by purchasing even more efficient vehicles than those mandated by Federal standards. It is assumed that the automobile industry is able to provide a mix of vehicles with the desired average efficiency. Because this assumption is questionable, a scenario was considered in which suppliers provide only the mandated fuel efficiencies through 1985. In this case, 1990 automobile fuel demand increased by 11 percent (or 1 quadrillion Btu) over the midprice case.

The forecast assumes that the diesel market share will not exceed 10 percent by 1985. An alternative scenario was considered in which the diesel share is 20 percent in 1985 and reaches 30 percent by 1990. In this case, fuel consumption is 0.3 quadrillion Btu lower in 1990 and 0.5 quadrillion Btu lower in 1995 than in the midprice case. In 1995, the total fleet fuel efficiency in the midprice case increases from 23.4 mpg to 24.6 mpg for automobiles and from 15.5 mpg to 16.1 mpg for light-duty trucks.

## **Residential and Commercial Energy Use**

The residential sector consists of approximately 80 million full-time residences in the United States. These include 53 million single-family homes, 23 million multifamily homes, and 4 million mobile homes. The commercial sector includes approximately 31 billion square feet of floor space, primarily composed of health services, educational facilities, retail-wholesale establishments, and office buildings. Together, these two sectors accounted for 31.2 percent of total net energy consumption in 1978. Natural gas provided 41 percent of the net energy consumed, electricity provided 22 percent, and oil provided 37 percent.

Figure 4.7 shows residential fuel use in 1990. Gas and oil are used primarily for space heating, which accounts for 60 percent of the energy used in this sector. The next largest end use, water heating, accounts for 15 percent. Space heating is also the major end use in the commercial sector, accounting for over 50 percent of commercial energy use.

End-use consumption remains almost constant in the midterm. As the fuel mix changes, electricity's share of the market grows at the expense of oil. (See Figures 4.8 and 4.9.) However, natural gas

consumption, in spite of a price advantage over electricity, remains constant because of the efficiency improvements associated with electric heat pumps and the lack of new gas hookups in many parts of the country.

### **Forces Driving Demand**

The primary factor driving historic and projected energy consumption in these two sectors is energy prices. Higher energy prices encourage individuals and firms to purchase more energy-efficient equipment, to improve the thermal integrity of their buildings, and to adjust their behavior patterns. These trends are reinforced by government programs designed to promote the efficient use of energy, including standards for new buildings and equipment, information programs, tax incentives to encourage the retrofit of existing buildings and the use of renewable resources, and grants to schools and hospitals. Also included is the Federal Energy Management Program, which encourages energy conservation in government buildings.

In the residential sector, improvements to both the shells of homes and the efficiency of appliances used for space heating, water heating, and air conditioning significantly reduce growth in energy consumption in the midterm. These reductions in energy use in existing homes offset the growth in new homes. Rising energy prices and government programs lead to the adoption of energy saving measures in both the residential and commercial sectors during the midterm.

Tables 4.7 and 4.8 show the comparative effectiveness of higher prices and conservation and renewable resource programs on residential and commercial energy consumption. For example, in the residential sector, the forecast energy consumption in 1990 is 11.0 quadrillion Btu, compared to the 13.5 quadrillion Btu that would have been consumed had prices remained constant from 1978 to 1990 and had the conservation and renewable resources programs not been in effect. The impacts of all three variables increase over time, except for the conservation programs in the commercial sector. Conservation impacts decline between 1990 and 1995 because retrofitting existing commercial structures is attributed to price effects in 1995, rather than to conservation programs that underlie commercial retrofits in 1985 and 1990.

In addition to energy prices, increases in personal income and the service component of total GNP influence energy demand in the commercial sector.



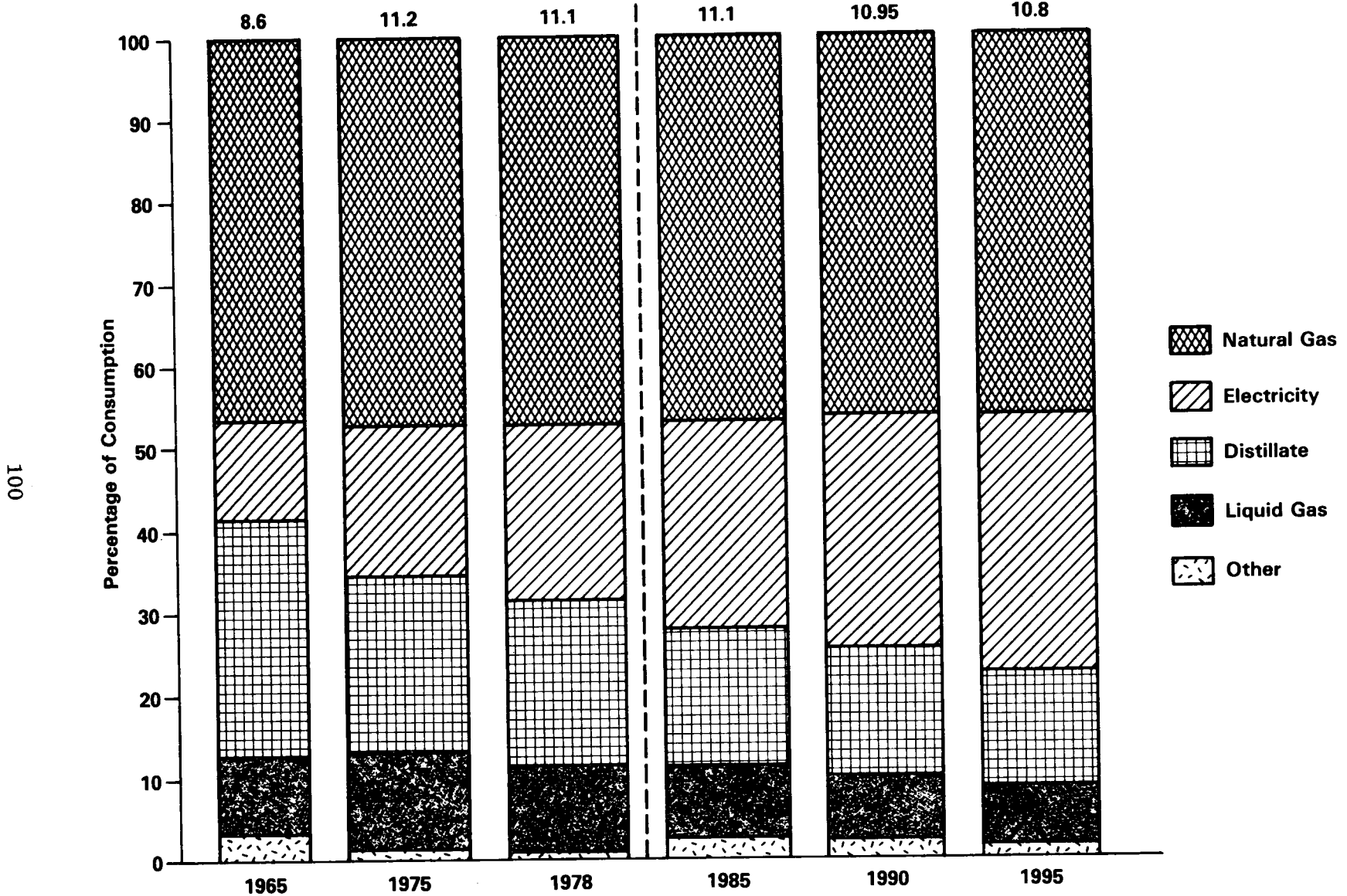

Figure 4.8 Residential Energy Fuel Shares by Source: Middle World Oil Price, 1965-1995

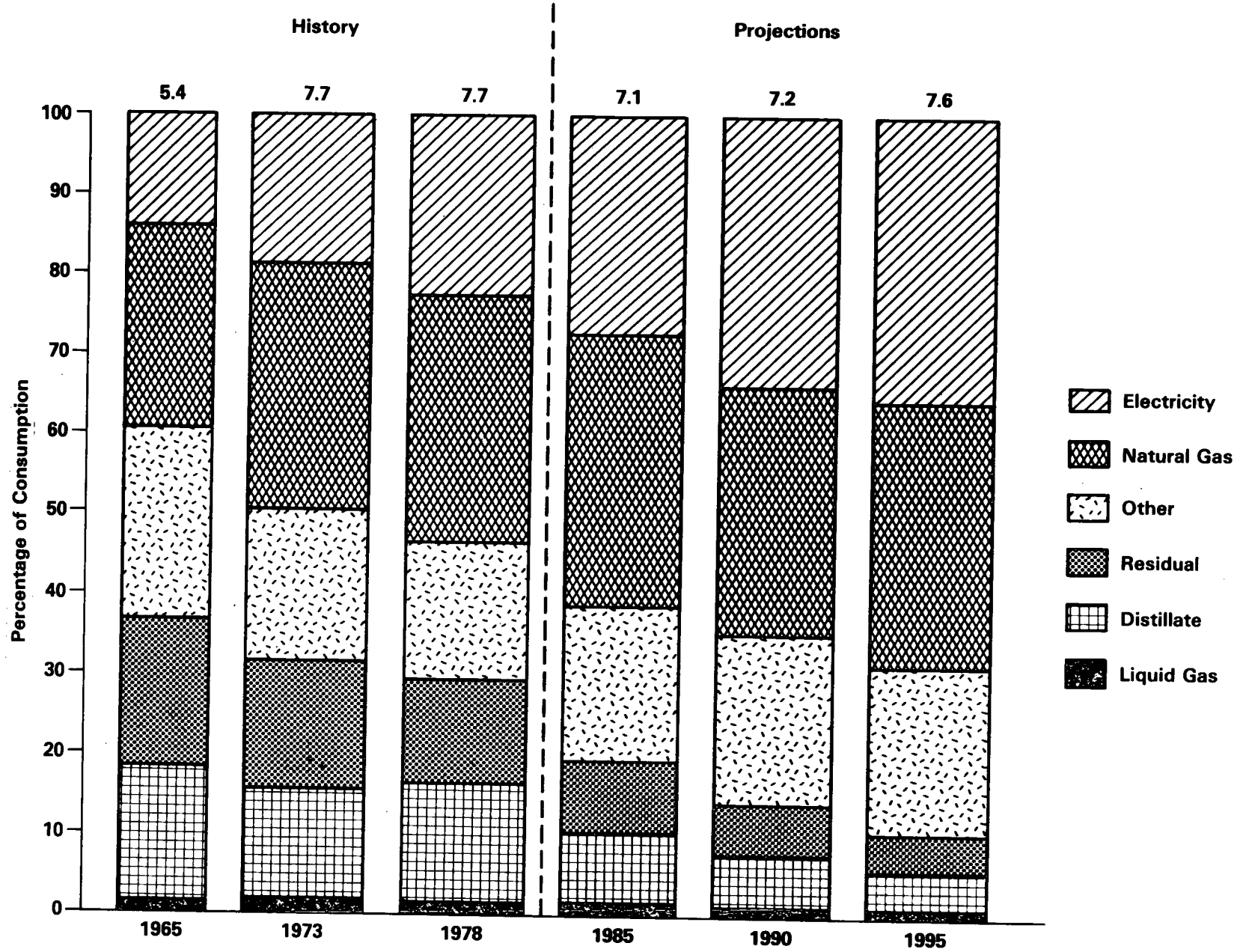

Figure 4.9 Commercial Energy Fuel Shares by Source: Middle World Oil Price, 1965-1995

**Table 4.7 Residential Sector: Impact of Energy Price Increases and the Energy Conservation and Renewable Resource Programs, Projections for Middle World Oil Price Scenario, 1985–1995 (Quadrillion Btu per Year)**

	1985	1990	1995
Base Level Consumption with 1978 Constant Prices .....	12.5	13.5	14.2
Impact of 1979 Annual Report Middle Price .....	-1.0	-1.8	-2.3
Impact of Conservation Programs .....	-0.3	-0.6	-0.7
Impact of Renewable Resource Programs .....	-0.0	-0.2	-0.4
1979 Annual Report Medium Projections .....	11.1	11.0	10.8

**Table 4.8 Commercial Sector: Impact of Energy Price Increases and the Energy Conservation and Renewable Resource Programs, Projections for Middle World Oil Price Scenario, 1985–1995 (Quadrillion Btu)**

	1985	1990	1995
Base Level Consumption with 1978 Constant Prices .....	8.2	9.1	9.9
Impact of 1979 Annual Report Medium Prices .....	-0.9	-1.3	-1.6
Impact of Conservation Programs .....	-0.2	-0.5	-0.5
Impact of Renewable Resource Programs .....	-0.1	-0.1	-0.2
1979 Annual Report Middle Projections .....	7.1	7.2	7.6

During the 25 years between 1950 and 1975, the output of the service component as a percentage of GNP increased from 35 to 43. During this same period, commercial energy consumption as a percentage of national energy use increased from 9.9 to 13.3. Several social changes contributed to this growth in GNP services. For example, growth in the number of secondary workers caused an increase in per capita income, and, at the same time, created an increase in demand for services formerly provided in the home. The growth of fast-food establishments is an example of this phenomenon. Increasing real family incomes also increased demand for commercial services such as recreation and lodging.

However, residential energy consumption is fairly insensitive to changes in income. Higher incomes increase the rate of growth in new housing and allow individuals to purchase larger homes with less sensitivity to higher energy prices; all tend to increase energy consumption. These

effects are partially offset, however, as individuals with higher incomes insulate their structures more effectively and purchase more efficient appliances. Population growth, which does influence energy consumption in this sector, has remained relatively constant historically and remains stable at 0.8 percent annually during the forecast period.

### History and Projections

For the reasons previously discussed, energy prices supplemented by government programs are the dominant influences on energy consumption in the residential and commercial sectors, both historically and in the midterm.

The rapid rate of growth in energy consumption (especially electricity) during the 1965 to 1973 period can be attributed to the decline in real energy prices and increased use of energy-using equipment, such as air conditioning. The situation changed dramatically after the 1973–1974 oil embargo. Net energy consumption actually declined in the residential sector and remained constant in the commercial sector between 1973 and 1978 because of the sharply rising oil and gas prices. (See Tables 4.9 and 4.10).

Commercial energy use declines between 1978 and 1985 and residential energy consumption remains almost constant in the midterm. Commercial use increases again after 1985 because price increases are not as sharp as in the past, and existing capital stocks have had more time to adjust to the price increases and no longer completely offset the growth from new starts. Homeowners and managers purchase more efficient equipment, insulate structures better, and change behavior patterns (for example by reducing average temperatures during heating periods.) Reduced energy consumption in existing buildings partially offsets the additional consumption from the 2 million new homes constructed each year and from the continued growth in commercial floor space (projected at 2.5 percent yearly). As energy-using equipment wears out, it is replaced by more energy-efficient equipment. Major improvements are expected in space heating such as:

- New commercial buildings built in 1990 will consume 50 to 75 percent less energy for space heating than will buildings constructed in 1977.
- Heat from lights, individuals, and the sun provide heat once provided by furnaces. Other end uses will also improve. On a national

**Table 4.9 Residential Energy Consumption and Prices: History and Projections for Three Base Scenarios, 1965–1995**  
(Quadrillion Btu, 1979 Dollars per Million Btu)

Fuel	History <sup>a</sup>			Projections								
	1965	1973	1978	1985			1990			1995		
				Low	Mid	High	Low	Mid	High	Low	Mid	High
Electricity.....	1.00	2.00	2.40	2.80	2.80	2.80	3.20	3.10	3.10	3.40	3.40	3.40
Price.....	14.86	11.09	12.69	15.71	15.80	16.01	16.22	16.56	16.70	15.90	16.14	16.23
Distillate <sup>b</sup> .....	2.30	2.40	2.20	1.90	1.90	1.80	1.90	1.70	1.50	1.80	1.50	1.30
Price.....	2.44	2.52	3.92	5.93	6.64	7.76	5.97	7.50	8.93	6.08	8.18	10.87
Liquid Gas.....	0.80	1.30	1.10	1.00	1.00	1.00	0.90	0.90	0.90	0.80	0.80	0.80
Price.....	2.19	2.51	3.61	6.98	7.72	9.82	6.98	9.10	11.07	6.98	9.82	13.57
Natural Gas.....	4.20	5.20	5.20	5.20	5.20	5.20	5.00	5.10	5.10	4.90	5.00	5.10
Price.....	2.27	1.98	2.68	3.86	3.83	3.81	4.86	4.65	4.40	5.47	5.06	4.68
Other.....	0.30	0.10	0.10	0.30	0.30	0.30	0.20	0.20	0.20	0.20	0.20	0.20
Total Consumption.....	8.60	11.20	11.10	11.20	11.10	11.00	11.10	11.00	10.90	11.00	10.80	10.70
Average Price.....	3.87	3.85	5.19	7.42	7.62	8.04	8.37	8.80	9.06	8.82	9.23	9.65

<sup>a</sup>Source of historical data is the State Energy Data System (see note a, Table 4.3).  
<sup>b</sup>Distillate includes kerosene consumption.

**Table 4.10 Commercial Energy Consumption and Prices: History and Projections for Three Base Scenarios, 1965–1995**  
(Quadrillion Btu and 1979 Dollars per Million Btu)

Fuel	History <sup>a</sup>			Projections								
	1965	1973	1978	1985			1990			1995		
				Low	Mid	High	Low	Mid	High	Low	Mid	High
Electricity.....	0.80	1.50	1.70	1.90	1.90	1.90	2.30	2.30	2.20	2.80	2.70	2.70
Price.....	13.77	10.58	12.84	16.13	16.24	16.45	16.61	16.92	17.06	16.26	16.49	16.56
Distillate.....	0.90	1.10	1.10	0.70	0.60	0.60	0.50	0.50	0.40	0.40	0.30	0.30
Price.....	2.15	2.21	3.63	5.61	6.32	7.44	5.64	7.16	8.60	5.73	7.82	10.51
Residual.....	1.00	1.20	1.00	0.70	0.60	0.60	0.50	0.50	0.40	0.40	0.40	0.30
Price.....	1.17	1.59	2.46	4.80	5.54	6.54	4.83	6.24	7.44	4.81	6.79	9.24
Liquid Gas.....	0.10	0.20	0.10	0.10	0.10	0.10	0.10	0.10	0.10	0.10	0.10	0.10
Price.....	2.19	2.51	3.61	6.95	7.70	9.80	6.94	9.06	11.04	6.93	9.79	13.53
Natural Gas.....	1.40	2.40	2.40	2.40	2.40	2.40	2.40	2.40	2.50	2.40	2.50	2.60
Price.....	1.55	1.41	2.31	3.37	3.33	3.31	4.37	4.19	3.93	4.97	4.60	4.21
Other.....	1.30	1.40	1.30	1.40	1.40	1.40	1.50	1.50	1.50	1.60	1.60	1.60
Total Consumption.....	5.40	7.70	7.70	7.20	7.10	7.00	7.40	7.20	7.10	7.80	7.60	7.50
Average Price.....	3.92	3.77	5.48	7.44	7.75	8.21	8.40	8.98	9.31	8.96	9.62	10.21

<sup>a</sup>Source of historical data is the State Energy Data System (see note a, Table 4.3).

average, energy used for air conditioning, water heating, and lighting per unit of floor space will decrease 20 to 40 percent.

Macroeconomic conditions also influence trends in commercial energy consumption during the midterm. The 1978 to 1985 decline in energy consumption is attributable to sharp price in-

creases coupled with low disposable income growth during 1973 to 1978. The growth in energy consumption resumes between 1985 and 1995, partially as a result of higher income growth.

The change in total energy consumption across the three scenarios of world oil prices is small, because electricity and natural gas prices are not significantly influenced by the changing oil prices.

In fact, the Natural Gas Policy Act subsidizes natural gas prices in these two sectors; gas prices, therefore, move in opposite directions from those of oil. (See the discussion on natural gas supply for a more thorough explanation of natural gas pricing.)

### Fuel Choice

The share of natural gas in total residential energy consumption remains relatively constant in spite of a low price relative to the price of electricity. The electricity market share increases while the market share of oil declines. Electricity's share in new housing increases for several reasons: one is the unavailability of natural gas in many parts of the country; another is that builders rather than homeowners select the fuel, weighing the decision more heavily toward electricity systems. Also, electric heat pumps are becoming more efficient for both heating and cooling. Heat pumps are from 75 to 150 percent more efficient than electric resistance heat and 150 to 250 percent more efficient than a gas furnace, depending on the region of the country. Today, newer heat pumps also operate much more effectively in the northern regions of the country, expanding the market for heat pumps. However, the development of using heat pumps may dampen the projected trend to electricity. (See Table 4.11.)

In the commercial sector, only electricity and petroleum products used in asphalt grow in the midterm. The natural gas market share increases slightly, while oil consumption declines dramatically. The use of petroleum fuels in the commercial sector declines significantly in the midterm, resulting in increased fuel shares for natural gas and electricity. (See Table 4.12.)

Electricity's increasing share, at the expense of oil, can be explained by several factors, but the primary force is the increasing price of oil as opposed to the almost constant price of electricity. In addition, during the last 10 years, electromechanical, cooling, and lighting energy use gained increasing shares of the commercial end-use market, while space heating and water heating shares declined. This trend continues into the future. Almost all of the oil used in the commercial sector is used for space heating. In the early 1970's, 40 to 50 percent of the new commercial buildings used oil for space heating. During the postembargo period, only 10 to 15 percent of the new commercial buildings used oil for space heat. Thus, oil is

**Table 4.11 Energy Consumption and Prices in the Residential Sector: Compound Annual Growth Rates, Projections for Middle World Oil Price Scenario, 1965–1995 (Percent)**

Fuel	History <sup>a</sup>		Projections			
	1965–1973	1973–1978	1978–1995	1978–1985	1985–1990	1990–1995
Electricity .....	9.0	2.9	2.1	2.5	2.3	1.4
Price .....	-3.6	2.7	1.4	3.2	0.9	-0.5
Distillate .....	0.6	-1.6	-2.3	-2.7	-2.0	-2.1
Price .....	0.4	9.3	4.4	7.8	2.5	1.8
Liquid Gas .....	6.4	-3.3	-2.3	-2.1	-2.3	-2.7
Price .....	1.8	7.5	6.1	11.5	3.3	1.5
Natural Gas .....	2.9	<sup>b</sup>	-0.3	<sup>b</sup>	-0.6	-0.2
Price .....	-1.7	6.3	3.8	5.2	4.0	1.7
Other .....	-9.8	-2.1	2.3	13.1	-3.1	-6.3
Total Consumption.	3.3	-0.1	-0.2	<sup>b</sup>	-0.3	-0.3
Average Price ...	-0.1	6.1	3.5	5.7	2.9	1.0

<sup>a</sup>Source of historical data is the State Energy Data System (see note a, Table 4.3).

<sup>b</sup>Less than .05 percent.

**Table 4.12 Energy Consumption and Prices in the Commercial Sector: Compound Annual Growth Rates, 1965–1995 (Percent)**

Fuel	History <sup>a</sup>		Projections			
	1965–1973	1973–1978	1978–1995	1978–1985	1985–1990	1990–1995
Electricity .....	8.4	3.4	2.7	1.6	3.3	3.6
Price .....	-3.2	4.0	1.5	3.4	0.8	-0.5
Distillate .....	2.4	1.2	-6.7	-8.3	-5.7	-5.4
Price .....	0.4	10.5	4.6	8.2	2.5	1.8
Residual .....	2.3	-3.1	-6.1	-7.0	-6.0	-4.8
Price .....	3.9	9.1	6.2	12.3	2.4	1.7
Liquid Gas .....	6.3	-3.3	-1.3	-0.8	-0.9	-2.3
Price .....	1.8	7.5	6.1	11.4	3.3	1.6
Natural Gas .....	7.5	-0.1	0.3	<sup>b</sup>	0.1	0.8
Price .....	-1.2	10.5	4.1	5.4	4.7	1.9
Other .....	1.4	-1.7	1.2	0.9	1.7	1.1
Total Consumption.	4.6	<sup>b</sup>	-0.1	-1.2	0.4	1.1
Average Price ...	-0.5	7.8	3.4	5.1	3.0	1.4

<sup>a</sup>Source of historical data is the State Energy Data System (see note a, Table 4.3).

<sup>b</sup>Less than .05 percent.

used in a smaller share of a declining space heating market.

These factors, combined with the emergence of the electric heat pump and the natural gas moratorium, have influenced the growth of electricity use in the commercial sector.

### Sensitivity Analysis

Sensitivity studies of the energy consumption forecasts are based on four alternative projections: low and high aggregate economic demand (reflected in variations in economic growth) and low and high energy supplies (reflected in varying assumptions about the domestic energy resource base).

The particular alternate supply assumptions that were analyzed lead to smaller swings in consumption than those that accompany the particular alternate demand assumptions on that were chosen. As shown in the table below, the low economic assumptions result in a 0.4 percent lower annual growth rate in real GNP between 1978 and 1990 than in the base case. High economic assumptions increase the growth rate in real GNP 0.4 percent annually over the same period. A change of 0.4 percent annually in the growth rate of GNP is associated with a 0.3-percent variation in energy consumption growth.

**1978-1990 Growth Rates  
(Compound Annual Rate of Change)**

	Real GNP	Net Energy Consumption	Gross Energy Consumption
Base Case	2.6	0.4	1.1
Low Demand	2.2	0.1	0.8
High Demand	3.0	0.7	1.4
Low Supply	2.6	0.3	1.0
High Supply	2.6	0.4	1.2

The total effects of alternative economic projections differ considerably by end-use sector. These differing sensitivities are shown in the table below; the relative percentage affects energy consumption from a 1-percent variation in real GNP, based on the low and high demand sensitivity projections for 1990. Residential energy use is less sensitive to changes in economic activity,

because that sector's use of energy is less directly related to the production and distribution of goods and services.

**Percentage Impacts of a 1-Percent  
Change in Real GNP**

Total Net Energy	0.8
Residential	0.1
Commercial	0.5
Industrial	0.9
Transportation	1.1

Energy consumption in the commercial sector is much more sensitive to rates of income growth than the residential sector, because the level of income significantly affects the growth in new commercial floor space. Industrial and transportation energy consumption are even more intimately tied to economic growth, because industrial expansion and discretionary travel depend on the level of income and growth.

Most of the impact of varying supply assumptions is on natural gas consumption. Greater natural gas supply causes the substitution of natural gas for coal in the industrial sector because natural gas prices fall. Falling natural gas prices also result in increased residential and commercial natural gas consumption, which accounts for nearly all of the total consumption effects of supply variations in these sectors.

## ENERGY CONVERSION

### Electric Utilities

The demand for electricity during the midterm continues to grow slowly as it has since 1973, when real electricity prices began to increase. Since that time, residential, commercial, and industrial consumers have initiated conservation measures and improved the efficiency of their electrical appliances in response to higher prices. Ongoing conservation and the low growth in industrial production result in only a 3.2 percent average annual growth rate in electricity sales from 1978 through 1995. This rate is identical to the 1973 to 1978 rate of 3.2 percent, but it is sharply reduced from the preem-bargo rate of over 7 percent.

## Electricity Production

Electric utilities shift from using oil and natural gas for producing electricity to coal and uranium, as shown in Figure 4.10. Oil consumption in the middle world oil price scenario decreases to 1.3 quadrillion Btu (34 percent of the 1978 oil consumption) by 1985. Consumption remains stable until 1990 and decreases to 0.2 quadrillion Btu by 1995. (See Table 4.13.) This reduction in oil consumption occurs because of the high price of imported oil, the low growth in projected electricity demand, and an assumption that natural gas continues to be available to utilities. In the past, utility planners projected demand growth rates of over 5 percent yearly and scheduled new coal-fired and nuclear powerplant construction to meet this demand. As a result, excess capacity exists by 1985, unless the planned coal-fired powerplants are delayed or cancelled due to lower demand or the unavailability of capital. This excess capacity is used to replace existing oil-fired powerplants. The high cost of building new plants for early replacement of the oil-fired powerplants is offset by the savings in generation costs that result from burning alternative fuels. Significant oil consumption continues until 1990 in New England and the West, because the new capacity currently planned for 1990 is not sufficient to displace all the oil required by utilities in those regions.

Natural gas consumption declines slowly until 1995, when additional coal capacity is available for its replacement. It is assumed that electric utilities receive 5-year exemptions to those provisions of the Powerplant and Industrial Fuel Use Act that require reduced natural gas consumption in existing facilities before 1990 and limit consumption to 20 percent of current usage by 1990.<sup>1</sup> Conversions of existing plants from oil to gas are assumed to be acceptable, although construction of new gas-fired powerplants is not permitted. In 1990, gas consumption is 89 percent of the 1978 level; in 1995, however, gas consumption decreases to 61 percent as new coal plants are built and existing gas plants are retired.

Coal and uranium consumption continues to increase through the midterm projections. Nuclear growth is slower than the historical trend because of the lower demand rate, financial constraints, and planning uncertainties following the accident

<sup>1</sup> The availability of these unlimited 5-year exemptions is open to interpretation. If the gas supply is as forecast here, they will likely be available. If gas supply is not as high, they may not be available.

at Three Mile Island. Coal growth is increasing, but is limited through 1990 to current utility plans. These plans reflect the uncertainty of obtaining financing for coal expansion and the limited capacity of the boiler industry for producing new boilers.

Variations in world oil price, as shown in the low and high price cases, yield a consumption change of less than 1 quadrillion Btu in any fuel for 1985 and 1990. Limited substitution of natural gas or coal for oil in response to the world oil price, is projected to occur in these years. In the low case, however, utilities continue to use oil-fired steam plants in 1995 for intermediate and peak demand. In the high case, all oil-fired steam plants are retired and oil is used only in distillate turbines to meet peak demands. Coal consumption is 1.6 quadrillion Btu higher in the high case than in the low case and replaces the oil consumption.

The projections of electric utility generation capacity by plant type represent existing and new capacity modified by the projected fuel conversions. (See Table 4.14.) The fuel conversion includes 14 gigawatts of existing oil and gas capacity that converts to coal in 1985 and an additional 7 gigawatts in 1990. The oil- and gas-fired steam capacity and combined cycle capacity do not increase in the midterm because of restrictions imposed by the Powerplant and Industrial Fuel Use Act, which prohibits the construction of most new oil and gas facilities, unless severe costs are incurred with alternatives. Reserve margins are high in 1985, because of the early retirements of existing oil and gas steam plants. These retired plants remain in the rate base and contribute to reserve capacity but produce no electricity. In 1990, the reserve margin decreases because the peak demand for electricity increases by 20 percent from 1985. In contrast, additions to total capacity increase only 15 percent because, by assumption, capacity additions in 1990 are limited to current utility plans or are restricted by Federal regulations. By 1995, enough coal, nuclear, and hydroelectric capacity is added to meet increased demand and retire most of the existing oil-fired steam plants.

Since the oil embargo in 1973 and the subsequent coal strike in 1974, the price of electricity has been rising in real terms due to increased fuel costs. (See Table 4.15.) The historical trend continues through 1990 because of rising oil prices and increased capital expenditures. Capital expenditures increase because of the longer leadtimes for construction of new facilities, increased costs of

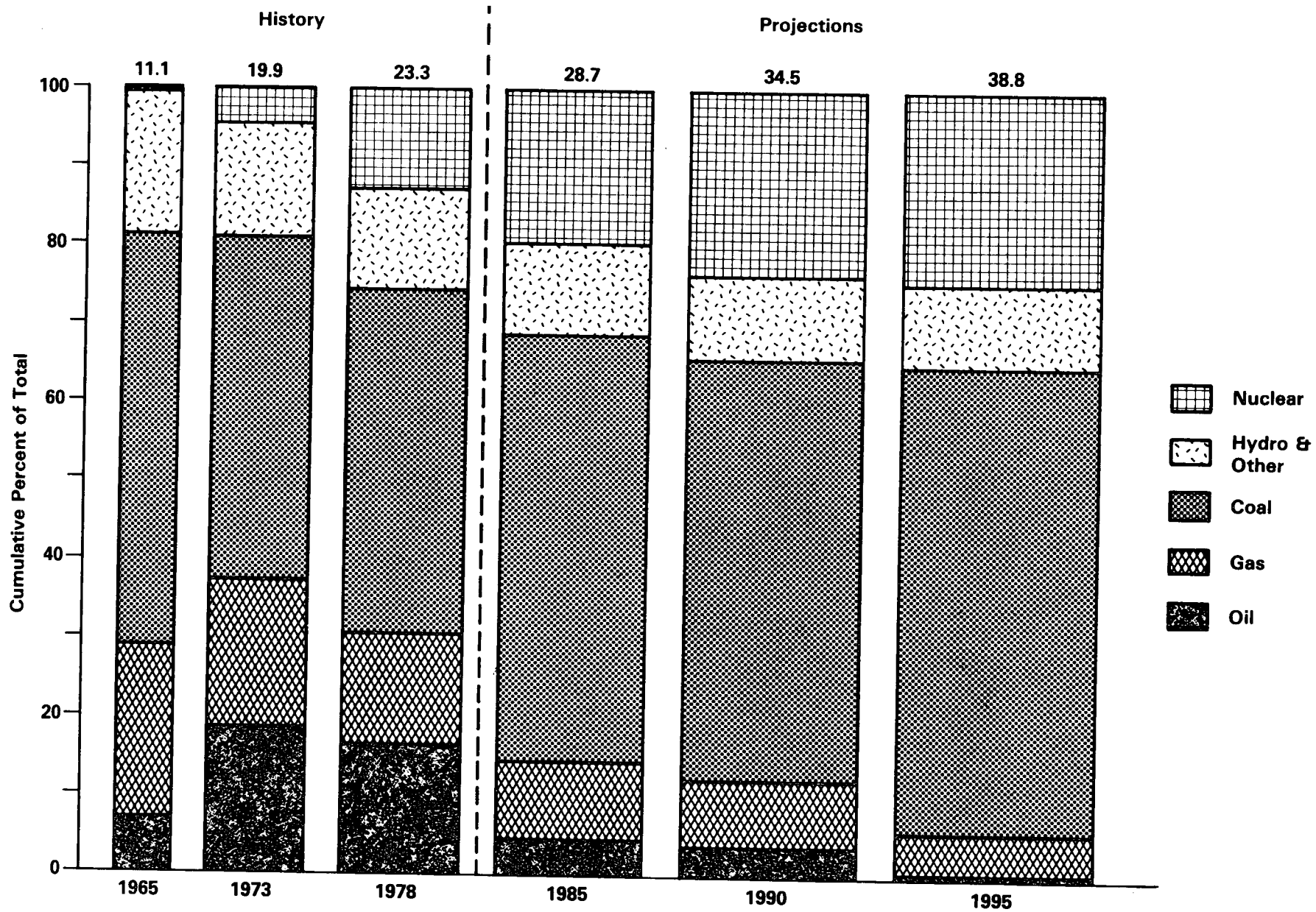

Figure 4.10 Distribution of Utility Fuel Consumption: Middle World Oil Price, 1965–1995



**Table 4.13 Electricity Fuel Consumption and Sales by Sector: History and Projections for Three Base Scenarios, 1965–1995**  
(Quadrillion Btu)

	History <sup>a</sup>			Projections								
	1965	1973	1978	1985			1990			1995		
				Low	Mid	High	Low	Mid	High	Low	Mid	High
<b>Fuel Consumption</b>												
<b>Fossil Fuels</b>												
Oil.....	0.8	3.6	3.8	1.6	1.3	1.2	2.1	1.3	1.1	1.6	0.2	0.1
Natural Gas.....	2.4	3.7	3.3	2.4	2.8	2.9	2.5	2.9	3.2	1.7	2.0	2.2
Coal.....	5.8	8.7	10.3	15.7	15.6	15.7	18.0	18.5	18.6	21.9	23.0	23.5
Subtotal.....	9.0	16.1	17.4	19.7	19.7	19.8	22.7	22.7	22.9	25.1	25.3	25.7
Nuclear.....	<sup>b</sup>	0.9	3.0	5.6	5.6	5.6	8.1	8.2	8.1	9.6	9.6	9.6
Hydroelectric.....	2.0	2.8	2.9	3.2	3.1	3.1	3.2	3.2	3.2	3.3	3.3	3.3
New Technologies.....	<sup>b</sup>	<sup>b</sup>	0.1	0.3	0.3	0.3	0.4	0.4	0.4	0.7	0.7	0.7
Total.....	11.1	19.9	23.3	28.7	28.7	28.8	34.5	34.5	34.7	38.7	39.0	39.4
Total Generation.....	3.6	6.4	7.5	9.2	9.2	9.2	11.0	11.0	11.1	12.6	12.8	12.9
<b>Sales</b>												
Residential.....	1.0	2.0	2.4	2.8	2.8	2.8	3.1	3.1	3.1	3.4	3.4	3.4
Commercial.....	0.8	1.5	1.7	1.9	1.9	1.9	2.3	2.3	2.2	2.8	2.7	2.7
Industrial.....	1.5	2.3	2.7	3.6	3.6	3.6	4.5	4.6	4.6	5.3	5.5	5.6
Total Sales.....	3.3	5.9	6.8	8.3	8.3	8.3	10.0	10.0	10.0	11.4	11.6	11.7

<sup>a</sup>Source of historical data is the State Energy Data System (See note a, table 4.3).

<sup>b</sup>Less than .05 quadrillion Btu.

Note: Sum of components may not equal due to rounding.

**Table 4.14 Electric Utility Generation Capacity and Reserve Margins: History and Projections for Three Base Scenarios, 1965–1995**  
(Gigawatts)

	History <sup>a</sup>			Projections								
	1965	1973	1978	1985			1990			1995		
				Low	Mid	High	Low	Mid	High	Low	Mid	High
<b>Plant Type</b>												
<b>Fossil Steam</b>												
Oil.....	—	—	—	81	81	81	76	75	74	80	73	73
Natural Gas.....	—	—	—	65	65	65	62	63	63	56	63	63
Coal.....	—	—	—	297	297	298	332	346	348	408	445	455
Subtotal.....	187	321	400	443	443	443	470	484	485	543	580	590
Nuclear.....	1	21	54	86	86	86	125	125	125	148	148	148
Hydroelectric.....	44	62	71	87	87	87	95	95	94	106	106	105
Combined Cycle.....	—	—	—	8	8	8	8	8	8	8	8	8
Combustion Turbine <sup>b</sup> .....	5	38	55	65	<sup>c</sup> 67	77	74	<sup>c</sup> 82	95	79	<sup>c</sup> 90	107
New Technologies.....	—	<sup>d</sup>	1	4	4	4	7	7	7	12	12	12
Total Capacity.....	236	442	579	693	695	706	780	801	815	896	944	970
Peak Demand <sup>e</sup> .....	186	344	408	498	492	493	589	590	592	676	683	690
Reserve Margin (percent).....	26.7	28.5	41.8	39.2	41.3	43.0	32.4	35.9	37.9	32.6	38.2	40.6

<sup>a</sup>Source of historical data is Volume 2 of the EIA *Annual Report to Congress*, 1979.

<sup>b</sup>Includes internal combustion capacity.

<sup>c</sup>Distillate to natural gas turbine conversions are limited to one-half the available capacity because of the assumption that natural gas turbines can only operate for six months each year due to a lack of gas availability. If distillate to natural gas conversion were assumed to be unlimited, turbine capacity would be reduced by approximately 6 gigawatts in 1985, 12 gigawatts in 1990, and 15 gigawatts in 1995.

<sup>d</sup>Less than .5 gigawatts.

<sup>e</sup>Edison Electric Institute, *Statistical Year Book of the Electric Utility Industry for 1978*, November 1979, p. 13.

Notes: Sum of components may not equal due to independent rounding.

— indicates data not available.

material and labor, and higher costs of capital. Expenditures also increase because capacity additions are made to retire the expensive, oil-fired powerplants before the end of their useful life. By 1995, the real price of electricity decreases because the consumption of expensive oil decreases to a negligible level and a considerable portion of the capital stock has been depreciated.

### Uncertainty

An important uncertainty relating to these midterm forecasts is the availability of capital at reasonable cost to finance the projected powerplant construction. Since the early 1970's, the financial health of the utility industry has been strained due to higher fuel costs and fixed charges relative to revenues. The revenues have been lower than anticipated because of the continuing low growth in electricity demand. The construction of new powerplants requires increased capital because of longer leadtimes, greater construction costs, and higher financing costs. For most utilities, the cost of construction work in progress does not generate a cash return. The poor financial status of utilities, which is reflected in declining bond ratings, prices on common stock below book value, and common dividends that exceed cash earnings has led to increased costs for financing new powerplants and postponements of planned facilities.

The availability of oil and natural gas to the electric utility industry is also uncertain in the midterm. The Powerplant and Industrial Fuel Use Act of 1978 prohibits the use of natural gas and oil for new powerplants and limits the use of natural gas by existing facilities. Exemptions can be granted based on a cost comparison with alternative sources of producing electricity. Implementation of these Government regulations as well as

potential fuel shortages caused by reduced imports and decreased domestic supply affect the amount of alternative powerplant capacity required in the midterm.

The National Environmental Policy Act and the Clean Air and Water Acts are recent regulations developed for environmental control. The approval of siting for new generating and transmission line facilities, the time required to obtain necessary permits, and the implementation of the air emission and solid waste disposal regulations are areas of uncertainty influencing the construction time for new powerplants in the midterm.

Finally, demand in the midterm is uncertain. Future ratemaking policies, such as time-of-use pricing (proposed in the Public Utility Regulatory Policy Act of 1978) may influence the levels and patterns of consumption. Capacity expansion plans for the midterm must be made on projections of future demand patterns with uncertain knowledge of both future conservation measures and economic growth.

### Sensitivity Analyses

Several sensitivity cases were analyzed to determine the impact of uncertainties faced by the electric utility industry on the projections. The studies varied one assumption at a time in the base case with middle world oil prices. Table 4.16 presents the results for the electricity generation by fuel in 1990.

The load management case assumes that time-of-use pricing for electricity is implemented, causing a shift in demand from the expensive peak hours of the day to offpeak hours. Generation from coal-fired powerplants increases in response to the increased demand in the base mode, and generation from oil- and gas-fired turbines decreases with the lower peak demand. The price

**Table 4.15 National Average Electricity Prices by Sector: History and Projections for Three Base Scenarios, 1965-1995**  
(1979 Mills per Kilowatt-hour)

Sector	History <sup>a</sup>			Projections								
	1965	1973	1978	1985			1990			1995		
				Low	Mid	High	Low	Mid	High	Low	Mid	High
Residential.....	50.1	37.2	43.9	53.6	53.9	54.6	55.3	56.5	57.0	54.3	55.1	55.4
Commercial.....	47.4	36.0	44.6	55.0	55.4	56.1	56.7	57.8	58.2	55.5	56.3	56.5
Industrial.....	20.0	18.3	28.2	38.4	38.6	39.2	40.5	41.6	41.8	40.1	40.8	40.9
National Average.....	35.4	29.1	37.7	47.4	47.7	48.3	48.9	50.0	50.2	48.0	48.6	48.6

<sup>a</sup>Source of historical data is Edison Electric Institute, *Statistical Year Book of the Electric Utility Industry for 1978*, November 1979, p. 53.

**Table 4.16 Electricity Consumption Fuel Mix: Sensitivity of Projections for 1990**  
(Quadrillion Btu)

Fuel Type	1990 Projections					
	1978 Actual	1979 Annual Report Middle	Load Management	Delayed Coal Capacity Expansion	Limit on Gas Consumption	Nuclear Moratorium
Coal.....	10.3	18.5	18.9	18.4	18.5	18.8
Oil.....	3.8	1.3	1.2	1.3	2.7	1.4
Natural Gas.....	3.3	2.9	2.6	3.0	0.6	3.1
Nuclear.....	3.0	8.2	8.2	8.2	8.1	7.6
Hydroelectric.....	2.9	3.2	3.2	3.2	3.2	3.2
New Technologies.....	0.1	0.4	0.4	0.4	0.4	0.4
Total.....	23.3	34.5	34.6	34.5	33.6	34.5

of electricity decreases 2 percent from the base case with the operation of more efficient plants and lower fuel costs resulting from the shift to coal. These cost savings more than offset the additional capital cost for changing meters to calibrate time-of-use rates.

The case for delayed coal capacity expansion assumes that coal-fired powerplants, scheduled to begin commercial operation by 1990, are delayed 2 years due to financial constraints and regulatory delays in obtaining permits. Only a small change occurs in the fuels used for electricity generation. Coal consumption declines slightly, while oil and gas consumption increase commensurately. New additions to the coal-fired capacity decrease only 2.3 gigawatts from the base case. The impact of this delay is minor because coal capacity additions of 114 gigawatts, projected in the base case, are already less than the current utility plans of 141 gigawatts nationally from January 1979 to December 1989.

The nuclear moratorium case assumes that plants currently less than 10 percent complete will be cancelled. As a result, nuclear capacity additions decrease by 4 gigawatts in 1990. Electricity generation from coal, oil, and natural gas increase by 1.7, 9.0, and 4.5 percent, respectively, over the base case. The impacts of this moratorium are greater in 1995, however, and are discussed in more detail in the nuclear section that follows.

The limit-on-gas consumption case assumes that the Powerplant and Industrial Fuel Use Act will be strictly enforced. The Act limits natural gas consumption in 1990 to 20 percent of the 1977 consumption, and, because utilities have fewer options, oil-fired powerplants that were retired before the end of their useful lives continue to

operate. The level of generation from oil-fired powerplants is double the base case projection. Oil consumption increases to 2.7 quadrillion Btu (71 percent of the 1978 level) in response to a limited gas consumption of 0.6 quadrillion Btu. The average price of electricity increases by 1.2 mills per kilowatt hour (kWh) over the base case because of increased fuel costs.

## Nuclear Power

### Current Status of the Domestic Nuclear Power Program

Nuclear power and coal are the two alternatives to oil and gas that can generate large amounts of electricity and support further expansion of electric generating capacity over the next few decades.

As of March 31, 1980, 69 investor-owned and 2 DOE-owned nuclear reactors totaling 52.2 gigawatts were operational. As shown in Table 4.17, 105 reactors totaling 116.5 gigawatts were in various stages of construction, under construction permit review, or on order.

During 1979, nuclear power provided 11.4 percent of all electricity generated domestically, down from 12.5 percent in 1978. Causes for the nuclear generation decline in 1979 include the following: (1) the Nuclear Regulatory Commission (NRC) shut down five reactors for an extended period to modify some nuclear components in compliance with revised seismic requirements; (2) in the aftermath of the Three Mile Island accident, eight comparable reactors manufactured by the Babcock and Wilcox Company were shut down to

**Table 4.17 Status of U.S. Nuclear Powerplants as of 31 March 1980**

Reactor Status	Boiling Water Reactors	Pressurized Water Reactors	Other <sup>a</sup>	Total Reactors	Net Megawatts Total Capacity
Operating <sup>b</sup> .....	26	42	3	71	52,200
Construction Permit Granted.....	28	60	0	88	96,700
10 Percent Complete or Better.....	19	42	0	61	66,900
Less Than 10 Percent Complete.....	6	11	0	17	19,300
No Construction.....	3	7	0	10	10,500
Under Construction Permit Review.....	7	6	1	14	16,300
Ordered.....	0	3	0	3	3,500
Announced.....	0	0	0	0	0
Totals.....	61	111	4	176	168,700

<sup>a</sup>Including one high-temperature gas-cooled reactor (Fort Saint Vrain), one liquid metal fast breeder reactor (Clinch River), and two DOE-owned reactors (Shippingport and Hanford N).

<sup>b</sup>Includes two DOE-owned reactors with a combined capacity of 940 MWe, Three Mile Island (906 MWe) which was shut down due to an accident in March 1979, and Humboldt Bay (65 MWe) which was shut down for seismic modifications.

<sup>c</sup>Including four units with Limited Work Authorizations, but for which no construction has been reported to date.

Based on *Program Summary Report*, U.S. Nuclear Regulatory Commission, NUREG-0380, Vol. 4, No. 4, March 1980.

determine the probability of a similar accident and to make required safety modifications.

Figure 4.11 illustrates the overall trend of historical and projected nuclear power growth through 1995. Throughout both the historical and projection periods, nuclear power increases in terms of generating capacity, actual production of electricity, and share of electricity generation. By 1995, nuclear capacity totals 148 gigawatts and generates 836 billion kWh of electricity, or 22 percent of total electricity. (See Tables 4.13 and 4.14.) Reactor capacity could reach 151 gigawatts by year-end 1995.

Units currently operating or under construction dominate the projected nuclear capacity in the 1980's. Approximately 57 percent of the 67 gigawatts of nuclear capacity now in advanced construction stages are completed by 1985. The major source of uncertainty in the 1985 forecast is the construction duration.

The major additional sources of uncertainty for 1990 include uncertainties in demand growth, accessibility to capital markets, and assessments by the electric utilities and State utility commissions of the risks and benefits of each nuclear power project. These factors primarily affect the amount of new nuclear capacity now under construction but less than 10 percent complete (19.3 gigawatts) and the capacity which is authorized but not yet under construction, for which the commitment to nuclear is revocable (10.5 gigawatts).

The same sources of uncertainty influence the deployment of nuclear power in 1995. In addition, nuclear plants not yet authorized for construction will be subject to uncertainty in the time required to process construction permit applications. Only 15 percent of reactors currently under construction permit review or on order will be completed by 1995 and no net increase in nuclear reactor orders is anticipated.

In general, the factors required for continued growth of nuclear power through the midterm include the following:

- A clear indication of increased demand for new electric generating capacity
- A major reassessment of utility financial practices and rate structures to relieve debt-equity and cash-flow burdens of new nuclear construction
- Resolution of uncertainties surrounding nuclear deployment, including the predictability of the licensing process, nuclear safety regulations, reactor siting, and long-term uranium availability
- Resolution of the nuclear waste disposal problem, particularly the construction of a Federal repository for the long-term disposition of highly radioactive wastes.

#### Sensitivities of Projected Nuclear Power Capacity

As suggested by Figure 4.11, nuclear power deployment throughout the midterm is affected

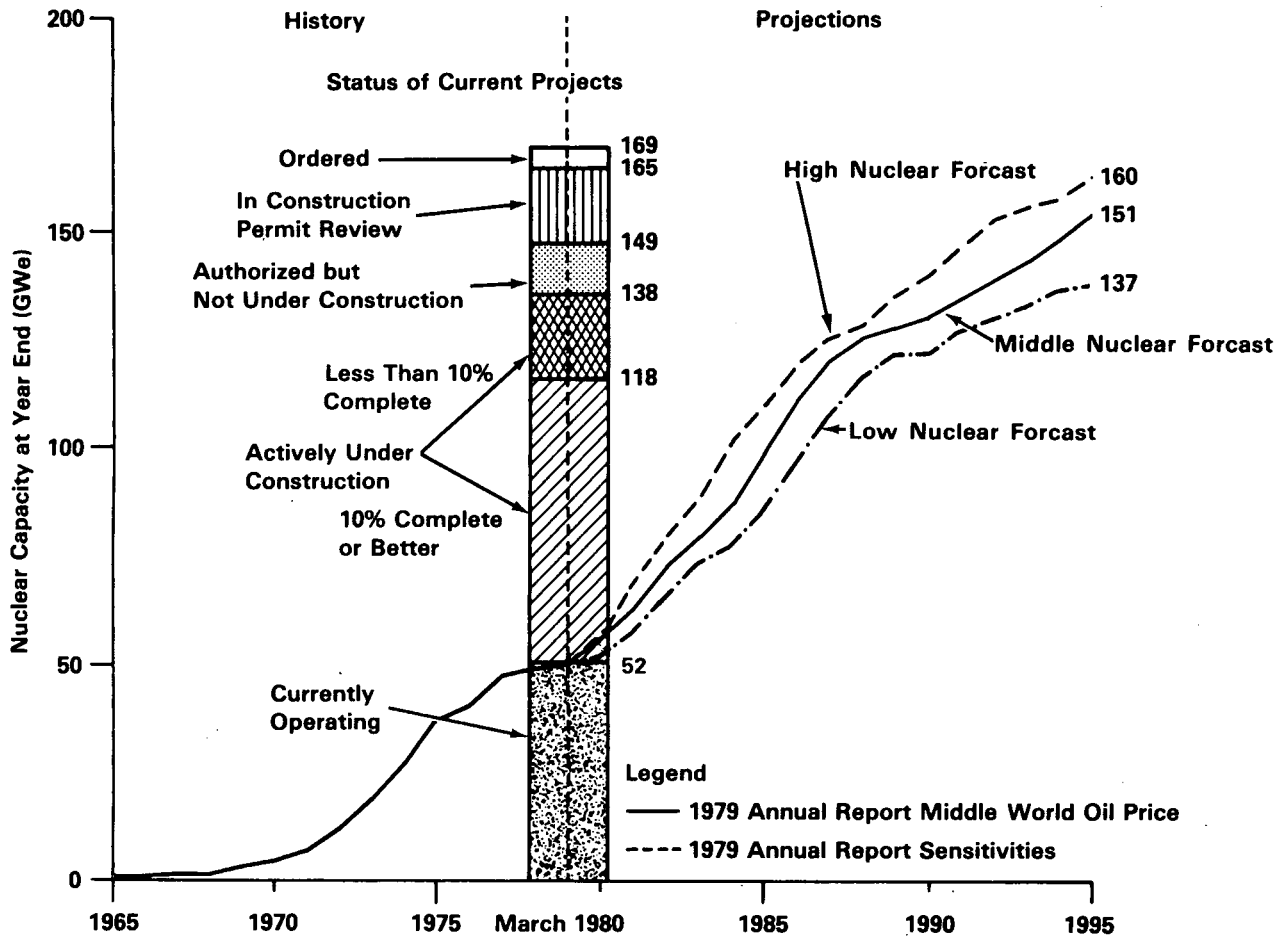

**Figure 4.11 Domestic Nuclear Power Capacity, 1965-1995**

most significantly by uncertainties associated with the time required for construction of a generating unit, followed in importance by uncertainties associated with the time required by the NRC to process and grant construction permits. Under today's conditions, a nuclear unit, if unhindered by financial or extraordinary regulatory factors, can be constructed in about 82 months following a licensing period of 32 months. These values were used to project the midprice case value of installed nuclear capacity through 1995. Shorter and longer leadtime assumptions provided the range about the medium case.

Real construction costs for nuclear reactors escalated approximately 100 percent from 1971 to 1978, primarily due to design changes for safety and environmental equipment, higher interest rates on borrowed capital, and increasing lead-times required to construct progressively larger reactor systems. As shown below, under the mid-price case assumptions for reactor licensing and

construction leadtimes, costs of new reactors beginning operation in 1995 increase 60 to 100 percent.

**Historical and Projected Nuclear Reactor Capital Costs (1979 Dollars per Kilowatt-Electric (1979 Installed Capacity))**

Operating Commercial Reactors (1/1/79)	Committed Reactors	Deferrable and New Reactors Operable by 1995		
		Low	Mid	High
660	990	1,065	1,185	1,420

The cost escalation results from several important factors. For example, some unresolved

safety issues could require appreciable changes in containment designs, reactor equipment, and control systems, with attendant cost escalation. Costs for plants entering service by 1985 are prepared from utility and architect-engineer estimates and do not consider the effects of such changes. However, the costs prepared by EIA for new reactors or those in earlier stages of design include assumptions for safety and design improvements of this nature. In addition, construction costs incorporate some real escalation of factor costs in recognition of recent trends. In all cases, however, these cost increases do not reflect the effects of other potential design changes that may result from the Three Mile Island accident. Evidence is mounting that new NRC requirements, related to that accident, could cost an additional \$25 to 30 million per reactor to implement.

The supply, demand, and price of nuclear fuel material and processing are sensitive to many factors other than the level of installed nuclear generating capacity or the generation of electricity from that installed capacity. For example, the demand for uranium is sensitive to both the operating mode of uranium enrichment plants and the efficiency of fuel utilization in the reactor. In addition, the supply and price of nuclear fuel are sensitive to miner productivity,

scarcity of uranium resources, costs of the temporary storage, and ultimate disposal of spent reactor fuel and radioactive wastes.

These forecasts are sensitive to the underlying assumptions regarding construction and licensing leadtimes and associated changes in capital costs. The high-nuclear supply case of Table 4.18 and Figure 4.11 shows that, under more optimistic assumptions for leadtimes and lower capital costs, nuclear capacity could rise to 167 plants and 160 gigawatts by 1995. From that nuclear capacity, 887 billion kWh would be generated or about 6 percent more electricity than the level produced by nuclear power in the midprice case. Expectations for longer leadtimes and higher capital costs in the low-nuclear supply case could reduce the nuclear contribution to 147 plants and 137 gigawatts producing about 761 billion kWh, approximately a 9 percent reduction from the midprice case forecast of 159 plants and 151 gigawatts.

A final sensitivity analysis for a construction moratorium on nuclear power assumed that only those reactors which were more than 10 percent complete would ultimately be completed and operated. These reactors constitute the "firm" base of capacity for which the financial commitment is too great to warrant cancellation. Under this assumption, by 1995, operating nuclear capacity is limited to 130 plants and 118 gigawatts

**Table 4.18 Midterm Nuclear Power Sensitivities: Domestic Projections for 1995**

	Middle	Nuclear Moratorium	Low Nuclear Supply	High Nuclear Supply
Installed Nuclear Capacity at Year End (gigawatt electric)	151	118	137	160
Total Busbar Generation, <sup>a</sup>				
Terawatt Hours Output	3,746	3,734	3,728	3,750
Quadrillion Btu Input	38.7	38.7	38.7	39.1
Nuclear				
Terawatt Hours	836	668	759	887
Quadrillion Btu	9.6	7.7	8.7	10.1
National Average Electricity Price <sup>b</sup> (mills per kilowatt-hour)	48.6	49.0	48.5	48.5
National Coal Demand				
Million Tons	1,570	1,663	1,603	1,553
Quadrillion Btu	33.1	34.6	33.7	32.6
Utility Coal Demand				
Million Tons	1,113	1,193	1,143	1,092
Quadrillion Btu	23.0	24.6	23.6	22.6
Imports Oil Demand				
Million Barrels per Calendar Day	5.7	5.7	5.7	5.7
Quadrillion Btu per Year	11.8	11.8	11.8	11.8
Utility Oil Demand				
Thousand Barrels per Calendar Day	110	110	110	110
Quadrillion Btu per Year	0.2	0.2	0.2	0.2

<sup>a</sup>Generation expressed in terawatt-hours (TWh) or billion kilowatt-hours.

<sup>b</sup>In constant (1979) dollars.

Note: Gigawatts installed capacity are year-end 1995 values, whereas Tables 4.14 and 4.15 represent beginning of the year values.

compared to 159 plants and 151 gigawatts in the midprice case. This reduced capacity produces about 668 billion kWh of electricity, about 20 percent less than in the midprice case. Total U.S. electricity demand is only slightly reduced, however, and electricity prices increase by less than 1 percent over those levels forecast in the midprice case.

## Refineries

During the midterm, demand for refined products declines sharply from 1978 levels due to higher prices and Government-mandated conservation programs. The quality and mix of products demanded change as the transportation sector becomes the major consumer of refined products while other sectors switch to alternate fuels. Tougher environmental standards force refiners to produce more unleaded gasoline and low sulfur fuel oil, while the quality of available crude oil declines as heavier and higher sulfur grades of crude oil are processed.

### The Refining Process

Crude oil is a complex mixture of hydrocarbons whose chemical properties vary widely. The individual components are separated at boiling point in a distillation tower. These components require further processing in order to meet the demands of consumers. Three of the major types of downstream units required are the following:

- Cracking and coking units which break up heavy hydrocarbons into lighter ones
- Reforming and alkylation units which produce high-octane blending stocks for gasoline
- Desulfurization units such as hydrotreaters.

Refinery utilization of distillation towers falls from close to 90 percent in the historical period to under 70 percent in 1985 because of sharply reduced demand, as shown in Table 4.19. This surplus capacity is concentrated in the Southwest, which currently ships much of its output to the East and Midwest. As demand declines and southwestern oil fields are depleted, southwestern refineries are at an increasing competitive disadvantage with eastern and midwestern refineries. Although the East and Midwest do not achieve self-sufficiency in refinery capacity (primarily because of environmental restrictions on new

construction), local refineries remain at high utilization levels and slowly expand their capacity. Therefore, total national refinery capacity increases despite falling demand. The analysis does not explicitly account for refinery retirements, although, given the large surplus in capacity, it is expected that some of the older refineries will be retired.

Although there is a surplus of distillation capacity in the midterm, new downstream units are required to process the available crude oil and meet tougher environmental standards on refined products. This requirement leads to a wider gap between the price of gasoline, which requires substantial downstream processing, and the price of distillate fuel oil, which requires relatively little processing, as presented in Table 4.20.

### Product Quantities and Prices

Gasoline demand declines from 1978 levels due to higher prices, Government fuel-efficiency standards, and the increasing market penetration of diesel-powered cars (discussed in the section on transportation demand).

Despite falling demand, little price relief is expected due to the higher costs of producing high-octane unleaded gasoline. The octane number of gasoline is a measure of its resistance to engine knock. Traditionally, lead has been used to boost the octane of gasoline. However, lead poisons the catalyst in pollution control equipment and is also thought to present a health hazard. The Environmental Protection Agency has therefore ordered a reduction of lead added to gasoline. In order to produce the extra unleaded gasoline, refiners must build new octane-boosting units. The cost of these units is passed on to consumers in the form of higher prices.

Middle distillate fuel oils are used in space heating, in utility and industrial boilers and process heaters, and as diesel fuel for cars, trucks, and buses. Demand for distillate declines sharply from 1978 levels in all sectors except transportation.

Distillate prices rose dramatically in 1979 because of the higher crude prices, the tight market, and the Government-ordered buildup of stocks to 240 million barrels in October 1979. The table below shows the increase in refiners' gross markup (not profit) on distillate heating oil over crude oil in 1979 over 1978. Local distributors also increased their markup during the shortages. This increase is not expected to be maintained in the midterm, due to a surplus in distillation capacity and an assumed

**Table 4.19 Petroleum Supply/Demand Balance: History and Projections for Three Base Scenarios, 1965–1995**  
(Million Barrels per Day)

	History <sup>a</sup>			Projections								
	1965	1973	1978	1985			1990			1995		
				Low	Mid	High	Low	Mid	High	Low	Mid	High
<b>Domestic Supply</b>												
Crude Oil <sup>b</sup> .....	7.8	9.2	8.7	8.0	8.1	8.2	7.9	8.3	8.5	7.2	8.1	8.5
Shale, Tar Sands and Synthetics.....	0	0	0	0	<sup>c</sup>	0.1	0	0.3	0.4	0	0.6	1.1
Natural Gas Plant Liquids.....	1.2	1.7	1.6	1.1	1.1	1.1	0.9	1.0	1.0	0.8	0.9	0.9
Refinery Gain.....	0.2	0.5	0.5	0.4	0.3	0.3	0.4	0.4	0.3	0.6	0.5	0.4
Other <sup>d</sup> .....	<sup>e</sup>	-0.1	0.1	NA	NA	NA	NA	NA	NA	NA	NA	NA
Subtotal.....	9.2	11.3	10.9	9.5	9.5	9.7	9.3	10.0	10.3	8.6	10.1	10.9
<b>Imports</b>												
Crude Oil <sup>b</sup> .....	1.2	3.2	6.4	5.7	4.8	4.3	7.0	4.6	3.7	8.3	4.7	2.9
Refined Products.....	1.3	3.0	2.0	1.1	1.1	1.0	1.2	1.1	1.0	1.9	1.1	0.9
Petroleum Exports.....	0.2	0.2	0.4	0.1	0.1	0.1	0.1	0.1	0.1	<sup>e</sup>	0.1	0.1
Net Imports.....	2.3	6.1	8.0	6.8	5.8	5.3	8.1	5.6	4.6	10.2	5.6	3.7
<b>Total Supply</b> .....	11.5	17.4	18.8	16.2	15.3	14.9	17.4	15.5	14.8	18.8	15.8	14.6
<b>Domestic Demand</b>												
Motor Gasoline.....	4.6	6.7	7.4	6.4	6.2	5.8	6.4	5.9	5.4	6.9	6.2	5.4
Distillate Fuel Oil <sup>f</sup> .....	2.4	3.3	3.6	3.1	2.9	2.8	3.4	3.1	2.9	3.7	3.1	2.7
Residual Fuel Oil.....	1.6	2.8	3.0	1.4	1.3	1.2	1.5	1.2	1.1	1.3	0.7	0.6
Jet Fuel.....	0.6	1.1	1.1	1.5	1.1	1.4	1.7	1.2	1.5	2.0	1.3	1.6
Other.....	2.3	3.4	3.8	3.9	3.9	3.8	4.5	4.2	4.0	4.9	4.6	4.4
<b>Total Domestic Demand<sup>g</sup></b> .....	11.5	17.3	18.9	16.3	15.4	15.0	17.5	15.6	14.9	18.8	15.9	14.7
<b>Total Domestic Demand</b> (quadrillion Btu per year).....	23.25	34.85	37.97	32.5	30.6	29.8	34.9	31.1	29.7	37.4	31.4	29.1
<b>Refinery Capacity</b> .....	10.4	13.7	17.1	19.3	19.3	19.3	19.8	19.8	19.8	20.2	20.2	20.2
Crude Runs.....	9.0	12.4	14.7	13.5	12.6	12.3	14.7	13.0	12.4	15.4	13.2	12.2
Percent Utilization.....	87	91	86	70	65	64	74	66	63	76	65	60

<sup>a</sup>Source for historical data is Volume 2 of the EIA *Annual Report to Congress*, 1979.

<sup>b</sup>Includes lease condensate.

<sup>c</sup>Less than .05 million barrels per day.

<sup>d</sup>Other refinery input, unaccounted for crude, change in stocks.

<sup>e</sup>Historical levels include imports from Strategic Petroleum Reserve, which began in 1977.

<sup>f</sup>Includes kerosene.

<sup>g</sup>Excludes exports, primarily to U.S. possessions in the Caribbean.

Note: NA indicates not applicable.

**Table 4.20 Refinery Product Wholesale Prices: History and Projections for Three Base Scenarios, 1965–1995**  
(1979 Dollars per Barrel)

	History <sup>a</sup>			Projections								
	1965	1973	1978	1985			1990			1995		
				Low	Mid	High	Low	Mid	High	Low	Mid	High
<b>World Oil Price</b>	6.00	6.50	15.50	27.00	32.00	39.00	27.00	37.00	44.00	27.00	41.00	56.00
Motor Gasoline.....	19.77	17.66	24.28	38.19	44.05	50.93	38.37	49.09	55.96	38.18	53.81	68.65
Distillate Fuel Oil.....	9.12	9.39	17.01	29.46	33.61	40.12	29.66	38.49	46.84	30.21	42.37	58.03
Residual Fuel Oil.....	7.01	8.20	12.71	27.76	32.38	38.64	28.06	36.93	44.42	28.26	40.59	55.89
Jet Fuel.....	11.03	9.10	17.97	30.97	35.21	41.85	31.32	40.10	49.88	31.71	44.38	61.59

<sup>a</sup>Source of historical data is the State Energy Data System (see note a, Table 4.3).



adequate supply of crude oil. Thus, distillate prices decline in real terms from their 1979 levels in the low case and rise more slowly than the price of crude oil in the middle and high cases.

**Gross Refiner Margin on Heating Oil  
(Cents per Gallon)**

	March	June	September	December
1978	6.4	5.4	5.5	7.3
1979	10.3	7.7	15.9	9.1

Source: Energy Data Reports, EIA-0018

Residual fuel oil is used in large utility and industrial boilers, in heating large buildings, and as bunker fuel in large ships. Because it does not flow easily, the transportation and burning of residual fuel oil requires special equipment. Although it competes with coal in many applications, its price will not fall to the Btu-equivalent price of coal because refiners can "crack" it into the more valuable lighter products. As a result, residual demand falls to less than half of its 1978 level during the midterm period, primarily due to industrial and utility conversions to coal.

Residual oil contains more Btu per barrel than crude oil, but because more heavy oil is usually produced by the distillation tower than can be sold, the lighter fractions are more valuable. The average price of residual remains below the crude oil price despite increasing production of low-sulfur residual oil.

**Uncertainties**

Gasoline-powered automobiles can also run on a mixture of gasoline and alcohol called gasohol. The alcohol can be either ethanol from agricultural products or methanol from coal or natural gas. Gasohol is exempt from Federal gasoline taxes and from State and local taxes in some areas. This analysis did not consider gasohol. Because alcohol raises the octane of gasoline, fewer octane boosting units would be required if gasohol were to become a major factor satisfying gasoline demand. However, a major expansion of alcohol production facilities would be necessary.

Small refineries currently receive a greater than proportional share of entitlements according to a sliding scale, based on the total capacity of the company owning the refinery. Large refiners who receive a lower share of entitlements pay for this small refiner bias. As currently established, the

program will expire with the end of domestic price controls on crude oil in 1981. Congress may decide to extend the program in some other form to encourage competition in the refinery industry. This analysis has assumed that the program is allowed to expire in 1981 and that the refinery industry is competitive without it.

In March 1980, President Carter imposed a \$4.62 per barrel tariff on imported oil which is allocated to gasoline through the entitlements mechanism. These projections do not include the tariff or any special tax on gasoline above historical levels.

**ENERGY SUPPLY—CRUDE OIL  
AND NATURAL GAS**

**Energy Supply**

Over 60 percent of the energy produced today in the United States comes from petroleum and natural gas. Petroleum is a mixture of hydrocarbon compounds with minor amounts of impurities, including nitrogen, oxygen, and sulfur. Petroleum occurs in the earth in reservoirs as a gas (natural gas), a liquid (crude oil), or a semisolid or solid (including asphalt and tar). Knowledge of its source is uncertain, but most geologists believe that petroleum is derived from marine organisms that accumulated on the bottom of ancient, shallow seas and were decomposed by bacteria, leaving residual hydrocarbons. Additional chemical changes resulted from subsequent burial by sediments. Eventually, the petroleum migrates into reservoirs. Variations in composition are attributed mainly to the temperature-pressure conditions during this process.

**Resource Base**

A fundamental uncertainty about future petroleum supply is the resource base—the amount of petroleum that remains in the ground. The resource base is classified according to its uncertainty and cost of extraction. Proved reserves refer to the amount of petroleum that is known with reasonable certainty to be producible under current economic conditions. In 1978, total U.S. proved reserves of crude oil as stated in a pre-release version of the replacement to circular 725 of the U.S. Geological Survey (USGS) are estimated to be 27.8 billion barrels (17.0, Lower-48 States onshore; 1.3, offshore; 9.6, north Alaska). Only about one-third of the total oil discovered is currently economically recoverable. Undiscovered

resources complete the oil resource base. Additionally, there are 200 trillion cubic feet (equivalent to 35 billion barrels of crude oil) of natural gas proved reserves.

In a recent partial revision of its estimate of undiscovered recoverable oil resources, the USGS lowered the mean values of the Lower-48 States onshore estimate by about 5 percent and the Lower-48 States offshore estimate by about 33 percent. The mean estimate for Alaska (including offshore) was up about 17 percent. This revision gives Alaska over 20 percent of these remaining oil resources.

## Exploration and Drilling

Undiscovered resources become proved reserves by the exploration process. Because no physical property of underground petroleum can be measured at the surface, the exploration process is risky and indirect. Geologic information is collected and analyzed by seismic measurement of subsurface geologic characteristics. The number of active seismic crews has been growing at an annual rate of 5.6 percent since 1973, and, today, use satellites to search for petroleum. The inferences from these processes lead to decisions to drill wells.

The actual location and size of a deposit can only be determined by drilling wells. The three basic types of exploratory wells are new field wildcat, new pool (reservoir) wildcat, and extension. A new field wildcat well, if successful, discovers a new field—one or more reservoirs located on a single geologic feature. Historically, only one in eight to ten new field wildcats finds oil in commercially producible quantities; the nonproducing wells are called dry holes. New pool wildcat wells find new reservoirs in existing fields, whereas extension wells extend the boundary of known fields. Although both extension and new pool wildcat wells involve risk, they are less risky than new field wildcats. The success ratio for all exploratory wells rose from 16 percent in 1971 to 29 percent in 1979, but this increase was not accompanied by a comparable increase in the amount discovered per successful well. This information raises questions concerning the composition of exploratory drilling activity. In this analysis, the composition of drilling patterns is assumed to remain constant over the forecast period.

Historically, total oil and gas footage drilled reached a peak in the mid-1950's, then declined to a

low in the early seventies. Since then, drilling footage has climbed steadily to a record high of 238 million feet in 1979. (See Figure 4.12.) In the low price case, drilling declines over the forecast period. In the midprice case, it peaks in 1990 and gradually declines thereafter. In the high price case, drilling climbs during the entire period, but its rate of growth declines after 1990. In all cases, Lower-48 States onshore drilling accounts for at least 90 percent of the footage.

## Reserve Additions

Successful exploratory drilling produces additions to proved reserves. Reserve additions are separated into crude oil and nonassociated natural gas. Reserve additions for crude oil peaked in the late 1960's and have been declining since. In all three price cases, the reserve additions increase until 1990 and decline thereafter. (See Figure 4.13.) Reserve additions for natural gas peaked in the late 1960's and declined to a low in the early 1970's. (See Figure 4.14.) In all three projections, the gas reserve additions increase through 1985 and decrease thereafter.

## Petroleum Liquids Production

The production process yields hydrocarbons that fall into three broad categories: natural gas, natural gas liquids (NGLs), and crude oil. Natural gas is found in the earth by itself (nonassociated) and associated with crude oils (dissolved). Natural gas liquids are separated from natural gas and used as refinery feedstock or consumed directly. Crude oil is broadly defined and ranges from a light volatile liquid to a dark viscous semisolid. Crude oil is brought to the surface by natural pressure in the reservoir or by artificial means. Recovery by natural forces or through the use of pumps is called primary. Artificial methods are of two kinds: secondary and tertiary. Secondary recovery includes the injection of water or natural gas into the reservoir to improve ultimate recovery. These methods are in wide use and have low associated risks. Tertiary methods (also called enhanced oil recovery) are newer technologies and have higher associated risks.

Figure 4.15 shows petroleum liquids production from various sources in the midprice case. In 1978, production from proved reserves was 8.4 million barrels per day. Production declines 11 percent annually to 1995 to 1.2 million barrels per day.

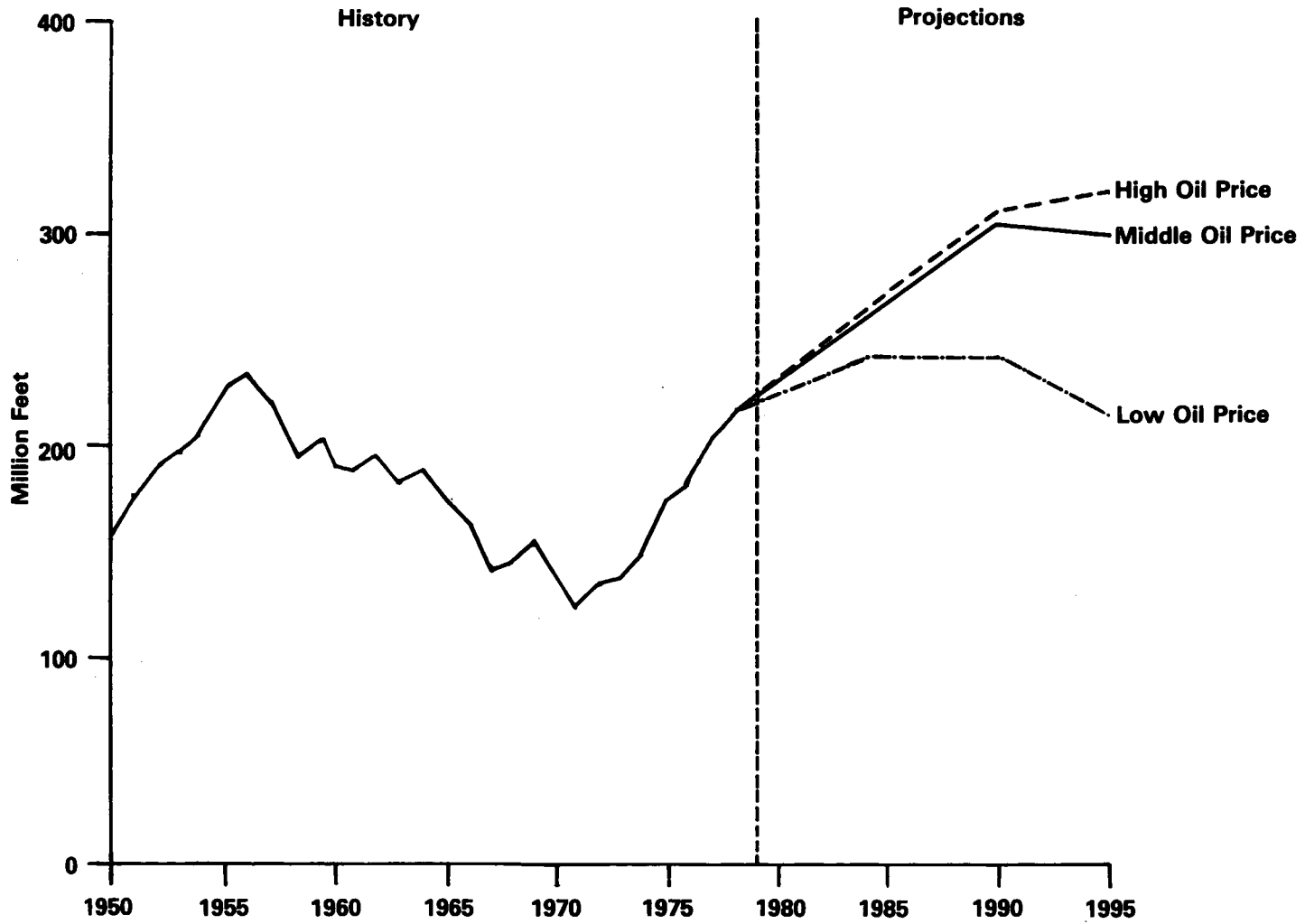

Figure 4.12 U.S. Oil and Gas Well Drilling, 1950-1995

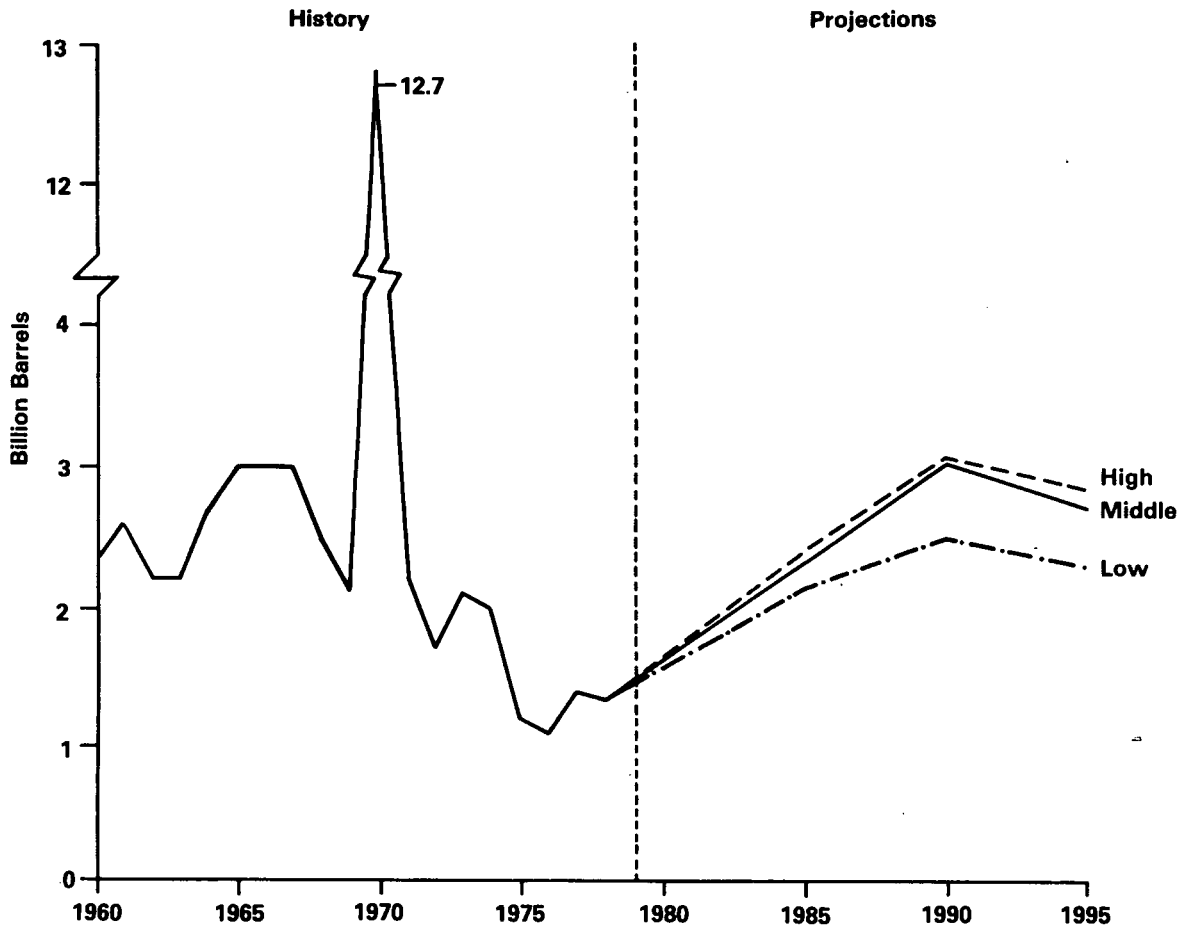

Figure 4.13 U.S. Oil Reserve Additions, 1960-1995

Indicated reserves are additional reserves that are expected to arise from future secondary recovery projects and account for 1.2 million barrels per day from 1985 through 1995. Production from new discoveries, which compensates for the declining production from current proved reserves, increases from 1.8 million barrels per day in 1985 to 4.8 million barrels per day in 1995. Enhanced oil recovery peaks in 1990 and declines thereafter, but production from oil shale, tar sands, and coal liquids, although negligible in 1985, increases to 7 percent of production in 1995.

### Lower-48 States Onshore Crude Oil Production

Table 4.21 presents a detailed breakdown of petroleum liquids production from principal sources and regions under the three price cases. Through the midterm the major source of domestic

production is the Lower-48 States onshore, the longest producing and most highly explored region in the world. Although drilling continues to increase in the middle and high cases, resource exhaustion results in declining production. The decline in production is assumed to be from proved and indicated reserves is unaffected by changing prices. This decline could be hastened by the addition of more development wells creating closer wellspacing. Production from new discoveries varies only 7 percent in the three price cases in 1985. Although there are reasonably large price variations by 1985, there is not enough time for significant production increases in response to higher prices. By 1990, the range over the three cases increases to 17 percent and, by 1995, it is 25 percent or 0.62 million barrels per day. Nevertheless, Lower-48 States production in all three cases declines through 1995. Lower-48 States production was 60 percent of total domestic production in 1978 but declines to about 40 percent in 1995.



Figure 4.14 U.S. Natural Gas Reserve Additions, 1960-1995

### Offshore Production

Production from the Outer Continental Shelf (OCS) introduces additional complexity into the exploration and production process. All offshore property is owned by Federal or State Governments, which lease to private interests for production. The Bureau of Land Management (BLM) designates the Federal offshore property to be leased each year. Leases are awarded to the highest bidder, who is then required to engage in drilling within a specified period of time. This year, the BLM's proposed acreage leasing schedule is approximately double that of previous years. Offshore drilling and production costs are higher than onshore; therefore, offshore fields must contain more oil in order for production to be economic. Offshore fields also have considerable time lags between discovery and production because of the difficulty and expense involved in constructing production and pipeline facilities offshore. For

frontier areas, the Atlantic, Pacific, and south Alaska, the lags are estimated to be 9 years. For the Gulf of Mexico, estimates are 5 years.

The recent pessimistic revisions of the USGS estimates of the offshore resource base are reflected in the offshore production projections in Table 4.21. The Gulf of Mexico accounts for 66 percent of the production in 1985 and 39 percent in 1995. With development lags, the effect of increasing prices on production is delayed. Consequently, the range of production from new discoveries due to price is negligible in 1985, 6 percent in 1990, and 12 percent in 1995. Over the midterm, the OCS contributes between 10 and 13 percent of the total liquids production.

### North Alaska

According to the most recent estimates by the USGS, an increasing share of the Nation's petrole-

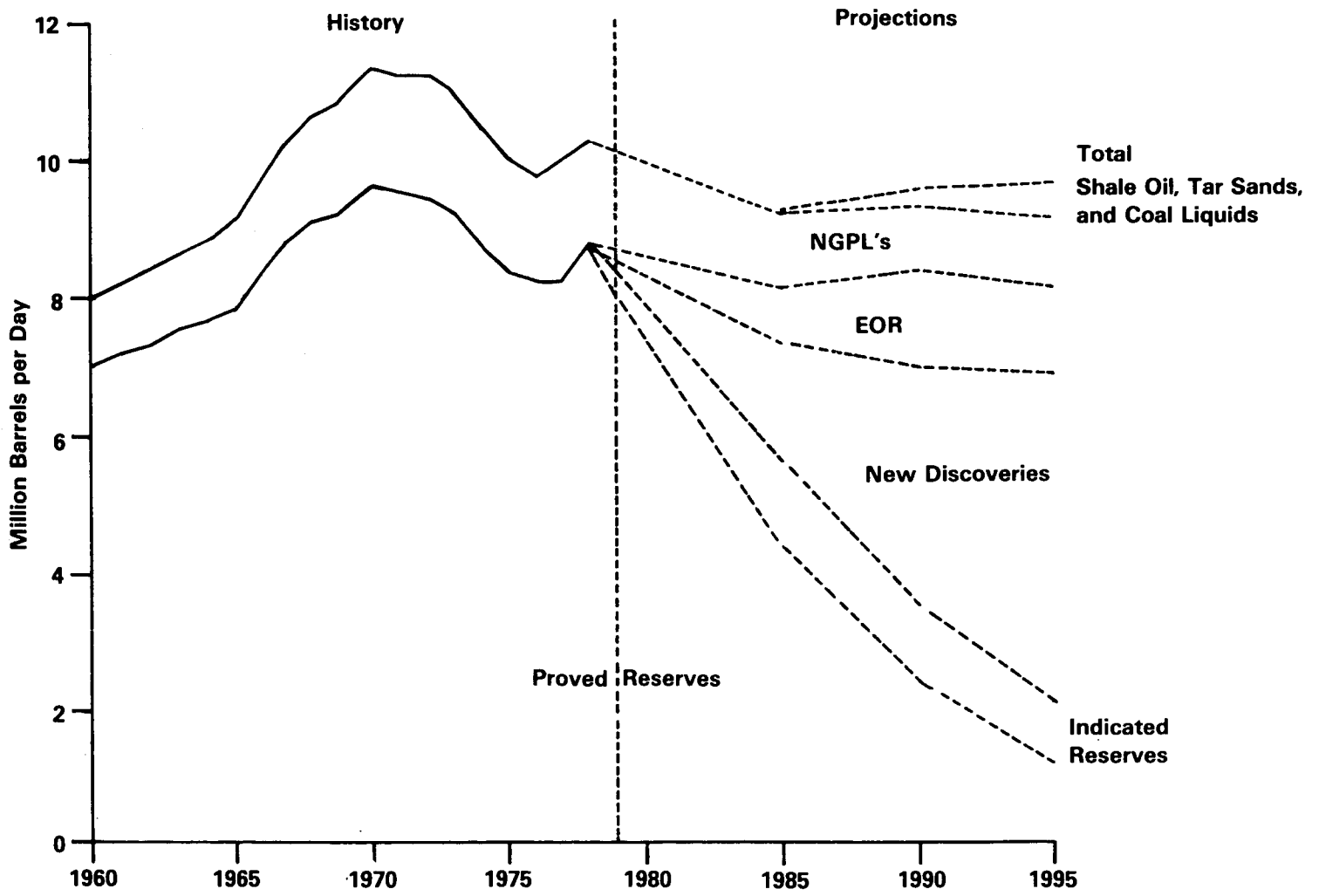

Figure 4.15 U.S. Petroleum Liquids Production by Source: Middle World Oil Price

**Table 4.21 Projections of Petroleum and Coal Liquids Production: History and Projections for Three Base Scenarios, 1965–1995**  
(Million Barrels per Day)

	History <sup>a</sup>			Projections								
	1965	1973	1978	1985			1990			1995		
				Low	Mid	High	Low	Mid	High	Low	Mid	High
World Oil Price (1979 dollars per barrel)	6.00	6.50	15.50	27.00	32.00	39.00	27.00	37.00	44.00	27.00	41.00	56.00
<b>Conventional Crude Oil Production<sup>b</sup></b>												
<b>Lower-48 States Onshore</b>												
From Proved Reserves .....	7.14	7.56	6.20	2.39	2.40	2.40	1.23	1.24	1.24	0.66	0.67	0.67
From Indicated Reserves .....	NA	NA	NA	0.88	0.88	0.88	0.88	0.88	0.88	0.75	0.75	0.75
From New Discoveries .....	NA	NA	NA	1.51	1.55	1.62	1.98	2.23	2.35	2.07	2.53	2.69
Subtotal .....	7.14	7.56	6.20	4.78	4.83	4.90	4.09	4.34	4.46	3.49	3.95	4.11
<b>Lower-48 States Offshore (Includes South Alaska)</b>												
From Proved Reserves .....	0.66	1.64	1.15	0.47	0.47	0.47	0.25	0.25	0.25	0.14	0.14	0.14
From Indicated Reserves .....	NA	NA	NA	0.28	0.28	0.28	0.22	0.22	0.22	0.17	0.17	0.17
From New Discoveries .....	NA	NA	NA	0.22	0.22	0.23	0.64	0.66	0.68	0.86	0.94	0.97
Subtotal .....	0.66	1.64	1.15	0.97	0.97	0.97	1.11	1.13	1.15	1.17	1.25	1.28
<b>Total, Lower-48 .....</b>	<b>7.80</b>	<b>9.20</b>	<b>7.38</b>	<b>5.75</b>	<b>5.80</b>	<b>5.87</b>	<b>5.20</b>	<b>5.47</b>	<b>5.61</b>	<b>4.66</b>	<b>5.20</b>	<b>5.39</b>
<b>North Alaska</b>												
From Proved Reserves .....	0	0	1.09	1.50	1.50	1.50	0.92	0.92	0.92	0.41	0.41	0.41
From Reserve Additions .....	NA	NA	NA	0.05	0.05	0.05	0.51	0.58	0.61	1.05	1.29	1.42
Subtotal .....	0	0	1.09	1.55	1.55	1.55	1.44	1.51	1.53	1.46	1.70	1.83
<b>Enhanced Oil Recovery<sup>c</sup></b>												
Steam Drive .....	—	—	0.15	0.50	0.53	0.53	0.81	0.88	0.88	0.63	0.71	0.73
Gas Flooding .....	—	—	0.11	0.14	0.14	0.14	0.31	0.32	0.32	0.31	0.35	0.36
Other .....	—	—	0.01	0.05	0.05	0.06	0.14	0.14	0.14	0.17	0.17	0.17
Subtotal .....	—	—	0.27	0.69	0.72	0.73	1.26	1.34	1.34	1.11	1.23	1.26
<b>Total, Conventional Sources .....</b>	<b>7.80</b>	<b>9.20</b>	<b>8.71</b>	<b>7.99</b>	<b>8.07</b>	<b>8.15</b>	<b>7.90</b>	<b>8.32</b>	<b>8.48</b>	<b>7.23</b>	<b>8.13</b>	<b>8.48</b>
<b>Unconventional Crude Oil Production</b>												
Shale Oil and Tar Sands .....	0	0	0	0	0.01	0.05	0	0.25	0.40	0	0.40	0.80
Coal Liquids .....	NA	NA	NA	0	0	0.03	0	0	0.03	0	0.23	0.26
<b>Natural Gas Liquids Production .....</b>	<b>1.21</b>	<b>1.74</b>	<b>1.57</b>	<b>1.11</b>	<b>1.11</b>	<b>1.11</b>	<b>0.94</b>	<b>0.99</b>	<b>1.00</b>	<b>0.80</b>	<b>0.89</b>	<b>0.90</b>
<b>Total Petroleum and Coal Liquids Production .....</b>	<b>9.01</b>	<b>10.95</b>	<b>10.27</b>	<b>9.10</b>	<b>9.19</b>	<b>9.34</b>	<b>8.84</b>	<b>9.56</b>	<b>9.91</b>	<b>8.03</b>	<b>9.65</b>	<b>10.44</b>

<sup>a</sup>Source for historical data is Volume 2 of the EIA Annual Report to Congress, 1979.

<sup>b</sup>Includes lease condensate.

<sup>c</sup>1978 Estimate from *Oil and Gas Journal*, March 27, 1978. The published estimate includes an additional .10 million barrels per day produced by Steam Soaking which is included in conventional oil production.

Notes: — indicates not available.

NA indicates not applicable.

um resources is located in Alaska. Preliminary revised estimates for undiscovered recoverable resources of Alaska, made too late to be used in this analysis, are 7 to 32 billion barrels and 30 to 97 trillion cubic feet of gas. The entire Outer Continental Shelf, including the Gulf of Mexico, contains an expected 12.5 to 38 billion barrels of oil and 61.5 to 139 trillion cubic feet of gas. This analysis used the mean estimates in USGS circular 725 for undiscovered recoverable resources in Alaska, which were 20 billion barrels of oil and 53

trillion cubic feet of gas. Over time, the share of U.S. resources located in Alaska has grown, due partially to the much lower rate of exploitation of resources in Alaska. Moderate levels of oil and gas have been produced in southern Alaska for years. Production of crude oil from northern Alaska was initiated in June 1977 with the opening of the Trans-Alaska Pipeline System (TAPS), which linked Prudhoe Bay on the Beaufort Sea with the southern port of Valdez on the Gulf of Alaska. Production of natural gas in northern Alaska for

commercial sales is not expected until late 1985 at the earliest.

Despite extremely adverse conditions, the production operations in these regions include all-weather facilities that allow production to occur throughout the year. TAPS itself operates on this basis. Until recently, the chief limit on production has been transportation capacity. By the beginning of 1979 pipeline capacity was 1.2 million barrels per day. Through the use of a drag reduction additive and expansion of facilities, flow had reached 1.5 million barrels per day by the end of the year. Additional construction can bring capacity to 2.0 million barrels per day if supply warrants. Litigation has stalled the recent efforts to sell leases for exploration and development of the offshore areas around Prudhoe Bay. Resolution of these difficulties is expected to occur in a timely fashion to permit further activity in the offshore areas. The Sadlerochit formation at Prudhoe Bay accounts for all production from proved reserves. (See Table 4.21.) Production from reserve additions is from the Kuparuk and Lisburne reservoirs at Prudhoe Bay in 1985 and includes the National Petroleum Reserve-Alaska and the Beaufort Sea in 1990 and 1995.

### **Enhanced Oil Recovery**

Enhanced oil recovery (EOR) techniques comprise three general categories:

- Thermal recovery, in which heat is applied to make the oil flow more easily
- Gas flooding, in which fluids are injected into the formation to dissolve the oil and form a liquid that flows more easily
- Chemical flooding, in which chemicals are injected into the formation to affect the interaction between the oil and its surroundings, allowing the oil to flow more easily.

Oil recovered using steam drive (a thermal technique) from shallow, heavy oil reservoirs in California contributes the bulk of EOR production through 1995. Production from these fields peaks around 1990 and then declines.

The use of gas flooding increases in importance and contributes 28 percent of EOR production in 1995, partially offsetting the decline in steam drive. The remaining production through 1995 comes from in-situ combustion, a thermal tech-

nique, and chemical flooding techniques, which include flooding with surfactant polymers and polymer-augmented waterflooding.

The actual timing of production from EOR is very uncertain. Delays in initiating projects will have a major impact on the schedule of production, because of the long leadtimes necessary for the study and development of EOR projects. Difficulties in meeting air quality standards for thermal projects and in developing adequate supplies of carbon dioxide for gas flooding are two areas that could potentially delay initiation of EOR projects and, consequently, production from these techniques through 1995.

### **Oil Shale and Tar Sands**

Two additional sources of petroleum are oil shale and tar sands. Massive formations of oil shale occur in Colorado and west of the Appalachian Mountains in the East. The eastern shales currently produce some natural gas, but are not likely to become a significant source of crude oil in the midterm. Environmental and commercial feasibility of large-scale production of crude oil from western shales pose key questions. Additionally, tar sands deposits, which occur mostly in Utah, do not contribute significantly to production in the midterm.

### **Natural Gas Liquids**

Natural gas liquids derive from both associated and nonassociated gas. Although natural gas production drops only 6 percent, natural gas liquids supply drops over 40 percent between 1978 and 1995. (See Table 4.24.) This larger decrease in natural gas liquids supply depends on several factors. Although associated natural gas accounts for only 12 to 16 percent of total natural gas production, the liquids from associated natural gas account for 44 to 49 percent of total natural gas liquids output. Thus, natural gas liquids supply is closely related to crude oil supply. In addition, associated natural gas liquids from north Alaska are mixed with crude oil and therefore not counted separately. Thus, reported natural gas liquids supply will follow Lower-48 States oil production more closely than gas production.



## Petroleum Imports

Imports of crude oil and refined petroleum products supplement domestic production of crude oil and natural gas liquids to meet total U.S. petroleum liquids demand. Chapter 2 details international petroleum supply capabilities. Table 4.19 and Figure 4.16 indicate the levels of petroleum imports required to balance projected domestic consumption levels. Projected import levels are highest for the low domestic supply and high domestic demand associated with low world oil price and are lowest for the high supply and low demand associated with high oil prices. In the midprice case, total imports decline to 5.9 million barrels per day in 1985 and to 5.7 million barrels per day in 1995. The relative mix of crude oil and product imports is fairly constant within each price case.

## Domestic Natural Gas Production

Production of natural gas by conventional techniques has exceeded the rate of reserve additions in recent years. This trend continues, although the gap between the two narrows. Consequently, conventional reserves continue their present decline and result in production declines as well. In the middle oil price case, yearly production of conventional gas declines roughly 1.5 to 2.0 trillion cubic feet every 5 years as shown in Table 4.22 and Figure 4.17. The production of associated and dissolved gas declines less rapidly than the production of nonassociated gas, due to the higher price incentives for crude oil.

The projections assume that the Alaskan Natural Gas Transportation System is not ready for operation until shortly after 1985. Projected demand for Alaskan gas is strong, however. The full initial capacity of the pipeline (2.4 billion cubic feet per day) is used in 1990 and expansion of capacity to 3.2 billion cubic feet per day is justified by 1995. Plans for financing and construction of the system, regulatory treatment, and cost estimates, however, are not final. Cost escalation resulting in tariffs for the system significantly above those published in the President's *Decision and Report to Congress on the Alaskan Natural Gas Transportation System* could lead to less demand for Alaskan gas than projected.

## Enhanced Gas Recovery

The projections consider two types of enhanced gas recovery. Production from western tight sands grows rapidly between 1985 and 1990 and increases further by 1995. Natural gas produced from Devonian shale located in the Appalachian region does not contribute as greatly to the Nation's supply, but it is developed aggressively and contributes 16.5 billion cubic feet in 1990. Production of methane from geopressured aquifers and coal seams has not been considered in the projections.

## Synthetic Gas

Production of high-Btu coal gas from two demonstration plants is included in the projections, accounting for less than 1 percent of gas production. Prices, however, do not rise sufficiently to justify the commercial production of high-Btu coal gas. Medium-Btu coal gas, manufactured close to the point of consumption, is economically attractive and contributes increasingly to the supply of gas in the next decade.

No synthetic natural gas is manufactured from liquid petroleum gases because of the high price of petroleum feedstocks, which make such gas too expensive to use even for satisfying peak demand. This development is in keeping with trends seen during the 1979-1980 heating season, when most synthetic natural gas plants were not operated.

## Imports of Natural Gas

The natural gas import situation is highly uncertain, primarily due to the discrepancy between prices for natural gas and alternative fuels in this country and the price of crude oil in world markets.

The pricing and supply of Canadian gas appears to be the most stable at the present time. The United States and Canada concluded an agreement in March 1980 that establishes a formula for escalating the price of Canadian imports, currently set at \$4.47 per million Btu. The formula prices Canadian gas at the Btu-equivalent price of Canadian crude oil imports, minus an adjustment that reflects savings to Canada of certain transportation costs. Moreover, the Canadian National Energy Board has recently approved increased exports to the United States.

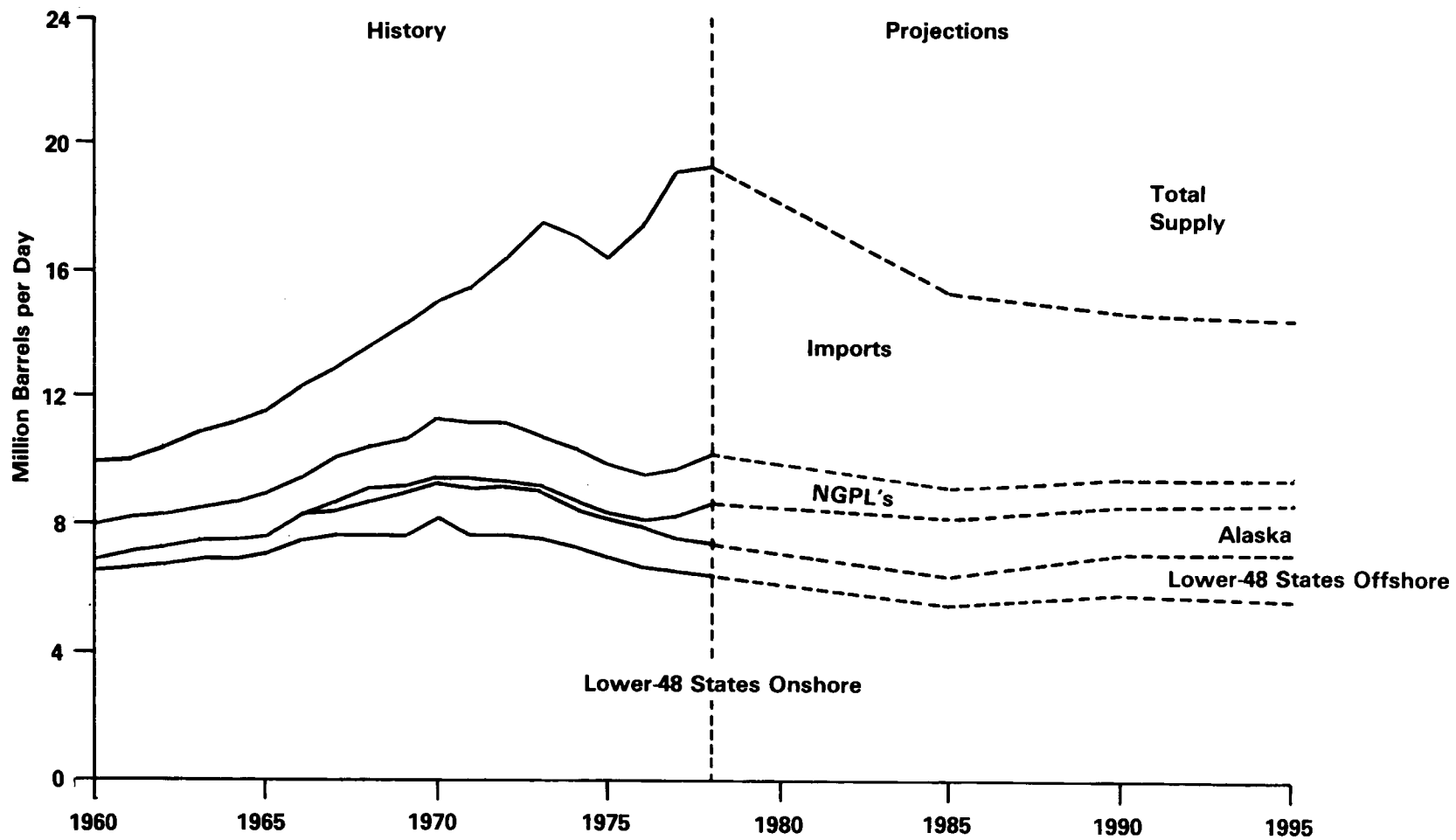

Figure 4.16 U.S. Petroleum Liquids Supply Including Imports: Middle World Oil Price

**Table 4.22 Natural Gas Production and Consumption: History and Projections for Three Base Scenarios, 1978–1995**  
(Quadrillion Btu per Year)

	History <sup>a</sup>			Projections									
	1965	1973	1978	1985			1990			1995			
				Low	Mid	High	Low	Mid	High	Low	Mid	High	
World Oil Price													
<b>Domestic Production</b>													
Conventional													
Associated and Dissolved...	—	—	—	1.9	1.9	1.9	1.7	1.8	1.9	1.6	1.8	1.8	
Nonassociated.....	—	—	—	14.4	14.4	14.4	12.6	13.0	12.9	10.3	10.9	11.1	
Subtotal.....	15.8	22.2	19.5	16.2	16.3	16.3	14.4	14.8	14.8	11.8	12.6	12.9	
North Alaska.....	0	0	0	0	0	0	0.9	0.9	0.9	1.2	1.2	1.2	
Enhanced Gas Recovery.....	b	b	b	1.9	1.9	1.9	3.0	3.0	3.0	4.0	4.0	4.0	
Synthetic Gas													
High-Btu Coal Gas.....	0	0	0	0.1	0.1	0.1	0.1	0.1	0.1	0.1	0.1	0.1	
Middle-Btu Coal Gas.....	0	0	0	0	0	0	0.1	0.2	0.3	0.4	0.6	0.6	
Synthetic Gas from Petroleum	0	c	0.3	0	0	0	0	0	0	0	0	0	
Total.....	15.8	22.2	19.7	18.2	18.2	18.3	18.5	19.0	19.1	17.5	18.6	18.8	
<b>Net Natural Gas Imports</b>													
Canadian Gas.....	0.4	1.0	0.9	0	0	0	c	0	0	0.8	0	0	
Mexican Gas.....	c	c	0	0	0	0	0.9	0	0	0.8	0	0	
Liquefied Natural Gas.....	0	c	c	0.8	0.8	0.8	0.8	0.8	0.8	0.9	0.8	0.8	
Total.....	0.4	1.0	0.9	0.8	0.8	0.8	1.8	0.8	0.8	2.5	0.8	0.8	
<b>Total Supply.....</b>	<b>16.2</b>	<b>23.2</b>	<b>20.6</b>	<b>19.0</b>	<b>19.0</b>	<b>19.0</b>	<b>20.2</b>	<b>19.8</b>	<b>19.9</b>	<b>20.0</b>	<b>19.4</b>	<b>19.6</b>	
<b>Consumption</b>													
Residential.....	4.2	5.2	5.2	5.2	5.2	5.2	5.0	5.1	5.1	4.9	5.0	5.1	
Commercial.....	1.4	2.4	2.4	2.4	2.4	2.4	2.4	2.4	2.5	2.4	2.5	2.6	
Raw Material.....	0.6	0.8	0.6	0.9	0.9	0.8	1.1	1.0	1.0	1.3	1.2	1.2	
Industrial, MFB <sup>d</sup> .....	e	e	e	0.4	0.2	0.2	0.5	0.2	0.2	0.6	0.2	0.2	
Industrial, Other.....	6.8	9.6	7.9	6.1	6.0	5.9	7.0	6.5	6.3	7.6	6.9	6.9	
Refinery.....	e	e	e	1.1	1.0	1.0	1.2	1.0	1.0	1.1	1.0	0.9	
Electric Utility.....	2.4	3.7	3.3	2.4	2.8	2.9	2.5	2.9	3.2	1.7	2.0	2.2	
Pipeline Fuel and Loss.....	0.5	0.7	0.5	0.5	0.5	0.5	0.5	0.6	0.6	0.5	0.6	0.6	
<b>Total Consumption.....</b>	<b>15.8</b>	<b>22.5</b>	<b>20.0</b>	<b>19.0</b>	<b>19.0</b>	<b>19.0</b>	<b>20.2</b>	<b>19.8</b>	<b>19.9</b>	<b>20.0</b>	<b>19.4</b>	<b>19.6</b>	

<sup>a</sup>Source for historical data is Volume 2 of the EIA Annual Report to Congress, 1979, and the following EIA Energy Data Reports: *Natural Gas Production and Consumption, 1978; United States Imports and Exports of Natural Gas, 1978; Natural and Synthetic Gas, 1978.*

<sup>b</sup>Included in conventional.

<sup>c</sup>Less than .05 quadrillion Btu.

<sup>d</sup>Major fuel-burning installations.

<sup>e</sup>Included in industrial, other.

Note: — indicates not available.

In September 1979, an agreement was also concluded between the United States and Mexico regarding the importation and pricing of natural gas. A price of \$3.62 per million Btu, effective January 1, 1980, was specified (to be escalated thereafter in proportion to the average price of five crude oils traded on the world market). The rapid increase in world oil prices between the time the agreement was concluded and the time the price escalation began, however, has resulted in the price of Mexican gas being substantially below the Btu-equivalent of world oil prices. Accordingly, Mexico may wish to invoke provisions in the agreement that would permit renegotiation of the formula.

In March 1980, Algeria announced that it is demanding \$6.00 per million Btu f.o.b. (free on board) for gas it exports to the United States under the El Paso I project and may discontinue these exports. The free on board price does not include transportation, terminal, and regasification costs, which are substantial. This change in Algerian export policy occurred too late to be incorporated into the forecasts. Because a reduction of gas imports by 1 quadrillion Btu is involved, the effect of the forecast would be significant, raising prices and production, reducing demand and the extent of incremental pricing, and, possibly, increasing imports from other sources.

All natural gas imports are assumed to be priced

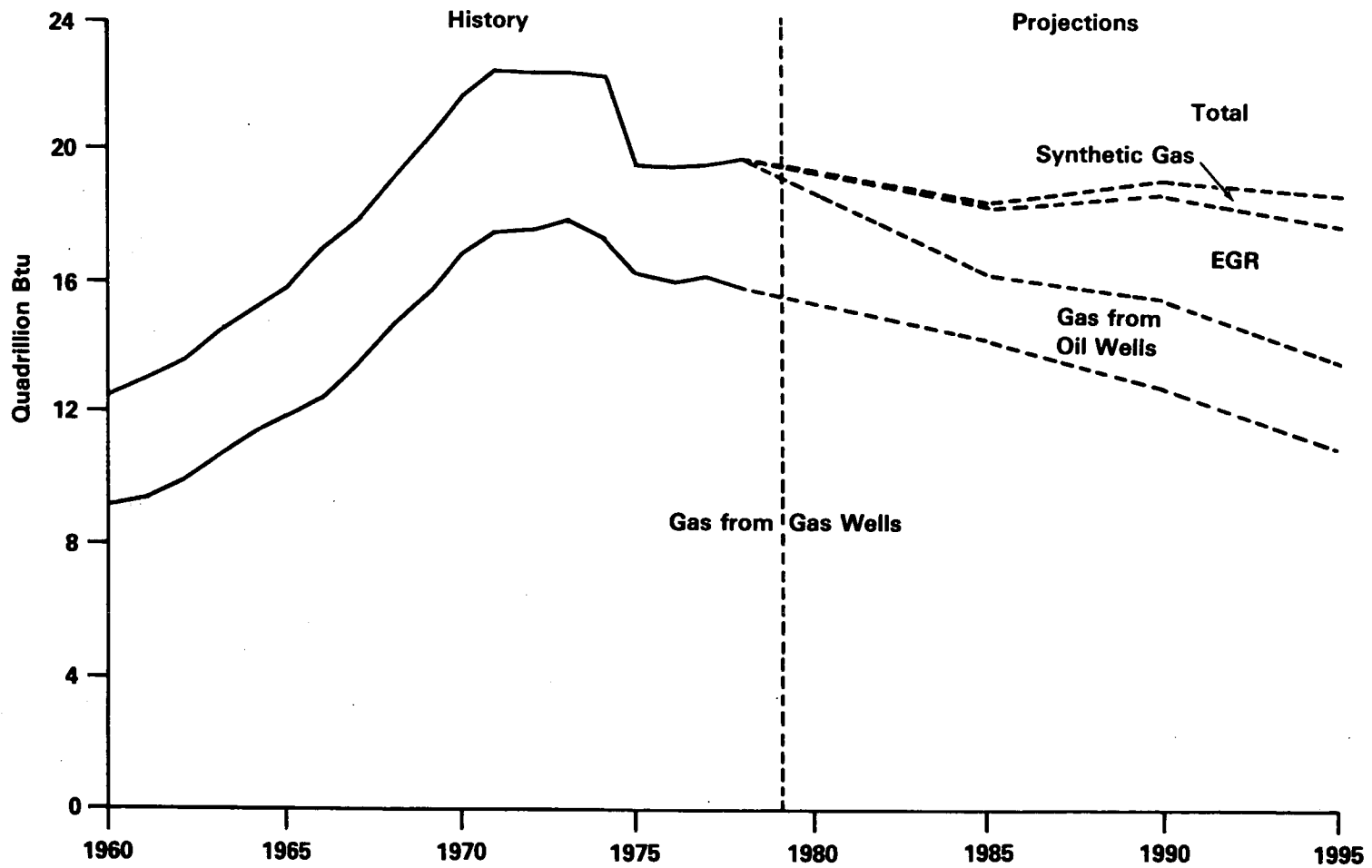

Figure 4.17 U.S. Natural Gas Production by Source: Middle World Oil Price

in accordance with the currently approved formulas (including \$1.59 per million Btu f.o.b. for El Paso I). Moreover, Canadian and Mexican imports were required to compete with domestic supplies, whereas LNG imports under the four projects currently approved were assumed to be purchased regardless of economic merit, due to long-term contracts that do not expire until the forecast period.

Under these assumptions, Canadian and Mexican gas imports are not competitive—a controversial conclusion. The California Public Utilities Commission, for example, announced in February 1980 that it expects Canadian gas imports to be needed at current levels throughout the 1980's, even at the price of \$4.47 per million Btu. An additional uncertainty concerns the willingness of Canada and/or Mexico to adjust their export prices downward if United States' domestic markets do clear at prices substantially below those of imported gas and if U.S. pipelines reduce or discontinue their purchase of imports.

### Natural Gas Prices

Under the Natural Gas Policy Act, wellhead prices are set by a combination of price ceilings and market competition. In the midterm, most gas production is decontrolled: very little new gas is subject to controls (mostly production from Prudhoe Bay); most old intrastate gas is decontrolled; and the quantity of old interstate gas (which remains controlled) declines rapidly over time.

The average price of interstate gas from old wells increases moderately over time. (See Table 4.23.) This price increase results from the price relief allowed some producers of old gas under the NGPA and the addition of some positive revisions, assumed to be priced at the maximum price allowed old gas. The average price of old intrastate gas increases more sharply due to the decontrol of most old intrastate gas in 1985. Production from new wells, whether sold to interstate or intrastate pipeline companies, is priced almost exclusively at the margin. In addition, the marginal price rises over time due to both depletion of gas resources and increases in demand due to growth in the economy and population.

The marginal price of gas in 1985 is below the ceiling price for new gas (\$2.95 per million Btu in 1985), indicating that the NGPA price ceilings would not be binding at the time of decontrol. In

1990 and 1995, the marginal wellhead price remains below the ceiling price (which would be \$3.63 per million Btu in 1990 and \$4.45 per million Btu in 1995), so that the NGPA price controls on new gas would not be binding even if they were extended through the forecast period.

The wellhead price of the Prudhoe Bay gas is limited under the NGPA to a maximum price of \$1.78 per million Btu, a ceiling that is binding in the projections. The increase in the national average wellhead price is due both to the increases in price for the various categories and to the decline in volume of the cheaper old gas.

The price of new gas is substantially below the Btu-equivalent price of oil due to a combination of factors. First, demand restraint measures, particularly the Powerplant and Industrial Fuel Use Act and the incremental pricing provisions of the NGPA, limit consumption of gas in the industrial and electric utility sectors. Second, in those sectors in which gas competes freely, oil consumption is declining as rapidly as rigidities in the economy will permit and gas is primarily competing with electricity and coal, the prices of which rise much less rapidly than the price of oil.

### Incremental Pricing

The Natural Gas Policy Act established a system of incremental pricing intended to protect the price of gas delivered to residential and other high priority users by allocating a disproportionate share of gas acquisition costs to industrial users.

Incremental pricing is effected by requiring interstate pipelines to divide their gas acquisition costs, at the point of first sale, into base costs and incremental costs. Base costs are then handled in the same manner as all gas acquisition costs were handled before implementation of the NGPA. Incremental costs are set aside to be passed on to industrial users in the form of a surcharge. However, the NGPA also established an "alternative fuel cost ceiling" that prohibits the incremental surcharge from pushing the total price of gas delivered to an industrial user above the Btu-equivalent price of an appropriate alternate fuel. Excess incremental costs not recoverable from industrial users, due to the alternative fuel cost ceiling, must then be recovered from all users in the same manner as the base costs.

The specific implementation of incremental pricing assumed for these projections approxi-

**Table 4.23 Natural Gas Prices: History and Projections for Three Base Scenarios, 1965–1985**  
(1979 Dollars per Million Btu)

	History <sup>a</sup>			Projections								
	1965	1973	1978	1985			1990			1995		
				Low	Mid	High	Low	Mid	High	Low	Mid	High
<b>World Oil Price</b>												
<b>Domestic Wellhead Prices</b>												
Old Interstate .....	—	—	0.90	0.84	0.84	0.84	0.98	0.98	0.98	1.10	1.10	1.10
New Interstate .....	—	—	—	2.71	2.71	2.71	3.39	3.65	3.38	3.84	3.99	3.81
Base Charge .....	NA	NA	NA	1.92	1.92	1.92	2.02	2.04	2.02	2.08	2.11	2.09
Incremental Charge .....	NA	NA	NA	0.79	0.78	0.78	1.38	1.61	1.37	1.75	1.88	1.72
Old Intrastate .....	—	—	—	1.86	1.87	1.87	2.76	2.92	2.75	3.11	3.20	3.09
New Intrastate .....	—	—	—	2.83	2.83	2.84	3.57	3.83	3.56	4.05	4.20	4.01
North Alaska .....	NA	NA	NA	NA	NA	NA	1.79	1.79	1.79	1.79	1.79	1.79
Average .....	0.35	0.34	0.99	2.10	2.09	2.09	2.93	3.15	2.93	3.50	3.63	3.49
<b>Synthetic Gas Prices</b>												
High-Btu Coal Gas .....	NA	NA	NA	6.10	6.10	6.10	6.21	6.21	6.24	6.32	6.33	6.33
Middle-Btu Coal Gas .....	NA	NA	NA	NA	NA	NA	4.37	5.64	6.73	4.46	6.02	7.51
Synthetic Gas From Petroleum	NA	—	—	6.93	8.15	9.46	6.92	8.94	10.47	6.98	9.72	12.87
<b>Imported Gas Prices</b>												
Canadian Gas .....	—	—	2.34	4.30	5.17	6.38	4.30	6.04	6.79	4.30	6.72	8.73
Mexican Gas .....	—	—	—	3.51	4.16	5.07	3.51	4.81	5.72	3.51	5.32	7.27
Liquefied Natural Gas .....	NA	NA	1.49	3.92	4.41	4.83	3.57	4.26	4.82	3.40	4.21	5.24
<b>Delivered Prices</b>												
Residential .....	2.27	1.98	2.68	3.86	3.83	3.81	4.85	4.65	4.40	5.47	5.06	4.68
Commercial .....	1.55	1.41	2.31	3.37	3.33	3.30	4.37	4.19	3.92	4.97	4.60	4.22
Raw Material .....	—	—	—	2.82	2.78	2.74	3.74	3.73	3.49	4.39	4.21	3.86
Industrial .....	0.76	0.75	1.56	3.36	3.47	3.56	4.06	4.85	4.90	4.42	5.40	5.78
Refineries .....	—	—	—	3.23	3.37	3.47	3.82	4.53	4.54	4.10	4.96	5.54
Electric Utilities .....	0.86	0.61	1.67	2.89	2.89	2.88	3.65	3.76	3.49	4.17	4.06	3.75
Alternative Fuel Cost .....	NA	NA	NA	4.31	5.05	6.06	4.36	5.79	6.93	4.32	6.41	8.79
<b>Interstate Industrial Price<sup>b</sup></b>												
Base Charge .....	NA	NA	1.68	3.98	4.23	4.44	4.38	5.75	6.19	4.55	6.38	7.29
Surcharge .....	NA	NA	NA	1.05	1.30	1.53	0.50	2.12	2.71	0	2.30	3.71
<b>Incremental Costs (million dollars per day)</b>												
NA	NA	NA	13.70	14.20	14.60	24.20	31.90	27.90	29.60	39.10	37.90	
<b>Surcharge (million dollars per day)</b>												
NA	NA	NA	9.80	12.40	14.40	5.30	21.20	25.00	0	22.40	34.70	
<b>Percent Passthrough of Surcharge</b>												
NA	NA	NA	72	87	98	22	67	90	0	57	91	

<sup>a</sup>Source for historical data is Volume 2 of the EIA *Annual Report to Congress, 1979*, and the following EIA Energy Data Reports: *Natural Gas Production and Consumption, 1978*; *United States Imports and Exports of Natural Gas, 1978*; *Natural and Synthetic Gas, 1978*.

<sup>b</sup>Average price to industrial users receiving interstate gas by assumption. These are all of the industrial uses in net consuming regions (which excludes DOE Regions 6 and 8).

Notes: — indicates not available.

NA indicates not applicable.

mates the regulations currently proposed by the Federal Energy Regulatory Commission (FERC). The alternative fuel cost ceiling is assumed to be the Btu-equivalent of the retail price of high-sulfur residual fuel oil, less \$0.10 per million Btu. All industrial users of natural gas, with the exception of electric utilities and those facilities that use natural gas as a feedstock, are subject to incremental surcharges.

The NGPA does not require that intrastate pipeline companies practice incremental pricing.

Because the projections are not based on an analysis conducted at the pipeline level, an approximation to distinguish between gas purchased by interstate pipelines and gas purchased by intrastate pipelines was developed. Consumption within a DOE region is assumed to be satisfied first by production within that region. Such gas is assumed to be intrastate and not subject to incremental pricing. Any consumption that cannot be satisfied by gas produced within the same region is then satisfied by gas produced in regions with an excess

supply. This gas is assumed to be interstate and subject to incremental pricing.

### Delivered Prices

Although natural gas wellhead prices are far below the Btu-equivalent prices of oil, incremental pricing pushes industrial prices to, or very near, the alternative fuel cost ceilings in those regions served by interstate gas. This projection, however, is only partially reflected in the national average industrial prices reported in Table 4.23. Because the major producing States satisfy their demand with intrastate gas, industrial users in these States are assumed to avoid incremental pricing altogether and pay a delivered price that is much less than the delivered price to industrial users in the net consuming States. This differential between the prices paid by industrial users receiving intrastate gas and those that must purchase incrementally priced gas is substantial and leads to a national average industrial price below the interstate industrial price obtained under incremental pricing. Moreover, this differential in industrial prices between the interstate and intrastate market yields a concentration of industrial gas consumption in the producing States, primarily in the Southwest (DOE Region 6).

Similarly, the national average delivered prices for the residential sector and other high priority sectors do not reflect the full extent of price protection afforded these users if they receive natural gas from the interstate pipeline system. Nevertheless, the effect of incremental pricing is evident, even in the national averages.

The effect of incremental pricing increases over time for three reasons:

- The amount of old interstate gas (which is too inexpensive to be incrementally priced) declines over time.
- The price of new interstate gas increases over time, so that incremental costs constitute a greater share of the acquisition cost.
- As the price of oil rises, the alternative fuel cost ceiling also rises, permitting a larger incremental surcharge to be passed on to industrial users.

The historical relationship between residential and industrial prices reverses during the forecast period, given this trend toward more extensive incremental pricing. Historically, residential delivered prices have been much higher than delivered

industrial prices, due to the higher distribution costs of serving residential customers. By 1990, the average industrial price is higher than the average residential price, and the differential grows in 1995 in the midprice case.

### Sensitivity of Natural Gas Forecasts to World Oil Price

Oil markets heavily influence gas markets, particularly the price of oil and the level of oil imports, due to several interrelationships between the two markets. Specifically:

- Oil and gas are coproducts; an increase in the price of oil will increase the production of both.
- Oil and gas are competitive fuels in many markets; an increase in the price of oil will increase the demand for gas in these markets.
- The PIFUA restricts the use of natural gas in the electric utility and major fuel-burning installation (MFBI) sectors. Because the test that permits or denies gas consumption is based on the price of residual fuel oil, an increase in the price of oil causes gas consumption in these sectors to decline.
- Under the incremental pricing of the NGPA, the extent of incremental pricing is limited by the alternative fuel cost ceiling; that is, by the price of residual fuel oil. Thus, if the ceiling is binding, an increase in the price of oil leads to higher gas prices and less consumption in the interstate industrial markets, together with lower gas prices and greater consumption in the residential, commercial, and electric utility sectors.
- In the refinery sector, the demand for fuel, including natural gas, is dependent upon the demand in other sectors for petroleum products.
- The macroeconomic impacts of a larger oil import bill will reduce demand for all fuels, including natural gas.
- The contracts for natural gas imports specify that the price is to be determined by formulas based on the world oil price.

The net effect of these mechanisms are shown in Tables 4.24 and 4.25. In 1985, the effects are small (in most cases less than 0.1 quadrillion Btu), but, by 1990, and especially by 1995, the effects are significant, due to both the higher differences in

the assumed world oil price in the three cases and to the longer period of time over which the price differences have acted.

The coproduct effect is strongest on a percentage basis for the Lower-48 States associated and dissolved gas (that is, gas produced from oil wells), but it is also present for the nonassociated gas because lease condensate and natural gas liquids produced along with the nonassociated gas receive prices comparable to crude oil. In 1990, the lower natural gas wellhead prices under the assumed high world oil price overwhelm the coproduct effect for nonassociated gas and lead to slightly lower production compared to the middle oil price case; in 1995, the reverse is true.

Alaskan North Slope gas production, which is constrained by pipeline capacity, does not respond

**Table 4.24 Sensitivity of Natural Gas Production and Consumption Projections in 1990 for the Middle World Oil Price Scenario**  
(Quadrillion Btu per Year)

	1990 Projections			
	1979 Annual Report Middle	High Geology	Low Geology	Low Finding Rate
<b>Domestic Production</b>				
Conventional				
Associated and Dissolved	1.8	1.9	1.7	1.6
Non-Associated	13.0	13.6	12.4	10.7
North Alaskan	0.9	0.9	0.9	0.9
Enhanced Gas Recovery	3.0	2.9	3.1	3.2
Synthetic Gas				
High-Btu Coal Gas	0.1	0.1	0.1	0.1
Middle-Btu Coal Gas	0.2	0.2	0.2	0.2
Synthetic Gas from Petroleum	0	0	0	0
Subtotal	19.0	19.6	18.5	16.8
<b>Net Natural Gas Imports</b>				
Canadian Gas	0	0	0	0
Mexican Gas	0	0	0	0.9
Liquefied Natural Gas	0.8	0.8	0.8	0.8
Subtotal	0.8	0.8	0.8	1.7
<b>Total Supply</b>	19.8	20.4	19.3	18.5
<b>Consumption</b>				
Residential	5.1	5.2	5.0	4.9
Commercial	2.4	2.5	2.3	2.3
Raw Material	1.0	1.0	1.0	1.0
Industrial, MFBI	0.2	0.3	0.1	0.1
Industrial, Other	6.5	6.7	6.4	6.2
Refinery	1.0	1.0	1.0	1.0
Electric Utility	2.9	3.0	2.8	2.6
Pipeline Fuel and Loss	0.6	0.6	0.6	0.5
<b>Total Consumption</b>	19.8	20.4	19.3	18.5

to oil price variations. Production of coproducts was not considered in the case for enhanced gas recovery.

Medium-Btu coal gas production responds to the price of crude oil because it competes with incrementally priced natural gas in interstate industrial markets. Accordingly, as the industrial price of gas in interstate markets rises due to incremental pricing, medium-Btu gas becomes more attractive to consumers. This stimulative effect of incremental pricing could be made available to high-Btu coal gas as well, if FERC authorizes the direct sale and transportation of such gas. Such an arrangement was not assumed in this analysis.

**Table 4.25 Sensitivity of Natural Gas Price Projections in 1990**  
(1979 Dollars per Million Btu)

	1990 Projections			
	1979 Annual Report Middle	High Geology	Low Geology	Low Finding Rate
<b>Domestic Wellhead Prices</b>				
Old Interstate	0.98	0.98	0.98	0.98
New Interstate	3.65	3.19	4.29	4.54
Base Charge	2.04	1.19	2.10	2.11
Incremental Charge	1.61	1.20	2.19	2.43
Old Intrastate	2.92	2.63	3.34	3.56
New Intrastate	3.83	3.35	4.51	4.86
North Alaska	1.79	1.79	1.79	1.79
Average	3.15	2.80	3.69	3.78
<b>Synthetic Gas Prices</b>				
High-Btu Coal Gas	6.21	6.21	6.21	6.21
Middle-Btu Coal Gas	5.64	5.40	5.58	5.83
Synthetic Gas from Petroleum	8.94	8.85	8.96	8.97
<b>Imported Gas Prices</b>				
Canadian Gas	6.04	5.99	5.99	5.99
Mexican Gas	4.81	4.81	4.81	4.81
Liquefied Natural Gas	4.26	4.26	4.26	4.26
<b>Delivered Prices</b>				
Residential	4.65	4.33	4.99	5.42
Commercial	4.19	3.85	4.53	4.97
Raw Material	3.73	3.37	4.07	4.54
Industrial	4.85	4.47	5.03	5.39
Refineries	4.53	4.11	4.79	5.27
Electric Utilities	3.76	3.34	4.15	4.67
<b>Alternative Fuel Cost</b>	5.79	5.71	5.82	6.00
<b>Interstate Industrial Price</b>	5.75	5.43	5.75	5.98
Base Charge	3.63	3.33	4.01	4.45
Surcharge	2.12	2.10	1.74	1.53
<b>Incremental Costs (million dollars per day)</b>	31.90	25.00	37.50	38.20
<b>Surcharge (million dollars per day)</b>	21.20	21.50	18.00	15.20
<b>Percent Passthrough of Surcharge</b>	67	86	48	40



Only in the scenario for a low world oil price, which assumes constant real world oil prices and thus constant prices for Mexican and Canadian gas, do pipeline imports become competitive by 1990. In the residential, commercial, and electric utility sectors, the interrelationships lead to increased gas consumption as oil prices increase, while in the other sectors the opposite is true.

The effect of incremental pricing depends greatly on the world oil price. In the low price case, the amount of incremental costs set aside at the point of first sale increases as the wellhead price of new interstate gas increases, but the capacity to pass these costs on as industrial surcharges declines. This decline in surcharge absorption capacity is due to two effects. First, the alternative fuel cost ceiling remains essentially unchanged. Second, the base charge, to which the surcharge must be added, rises over time because the proportion of cheaper old gas declines over time. As a result, by 1995 no incremental costs can be passed on in the form of surcharges.

In the middle and high cases, the rising alternative fuel costs ceiling allows higher pass on of surcharges in absolute terms, though the percentage pass on still declines. The general effect of incremental pricing, nevertheless, is to reduce gas prices to residential, commercial, and electric utility purchasers. Those sectors show increasing gas consumption as oil prices increase, while in other sectors the opposite is true.

These conflicting responses to oil prices cause a net decrease in consumption between the low and middle cases in 1990 and 1995 and a small net increase in consumption between the medium and high cases.

### Uncertainty in Domestic Petroleum Supply Projections

Five categories of uncertainties that surround crude oil and natural gas projections are the following:

- Amount and characterization of petroleum remaining to be discovered
- The difficulty of finding the undiscovered resources
- The profitability of production
- Technological progress
- Future environmental restrictions.

### Resource Uncertainty

The most critical uncertainties about future petroleum supply concern the amount, the characteristics, and the distribution of the remaining resources. All three aspects must be considered to properly address resource uncertainty. For example, one large reservoir with 1 million barrels is preferable to 100 reservoirs of 10,000 barrels each, and a reservoir producing light, low-sulfur crude oil is better than one producing the same amount of heavy, high-sulfur crude. The task of estimating these quantities is subject to high levels of uncertainty, partly due to the pool size distribution of discovered crude oil being highly skewed. For example, the 10 largest fields in the U.S. (out of hundreds) provide over 50 percent of the recoverable oil.

To examine the resource uncertainty, a Monte Carlo simulation of the USGS resource estimates was performed to incorporate the uncertain nature of the resource base. The high- and low-geology scenarios represent the 5th and 95th percentiles, respectively, of the simulation of the distribution of resource base. For crude oil, the difference in production between high and low geology is 5 percent in 1985, 13 percent in 1990, and 18 percent in 1995, as shown below. For natural gas, the difference is 11 percent in 1985, 15 percent in 1990, and 20 percent in 1995.

#### Resource Uncertainty

	Crude Oil (million barrels per day)					
	History			Projections		
	1965	1973	1978	1985	1990	1995
Low Geology	—	—	—	5.7	5.2	4.8
Medium Geology	7.8	9.2	7.4	5.8	5.5	5.2
High Geology	—	—	—	6.0	5.8	5.7

	Natural Gas (quadrillion Btu)					
	1965	1973	1978	1985	1990	1995
Low Geology	—	—	—	15.4	13.8	11.5
Medium Geology	15.8	22.2	19.5	16.3	14.8	12.6
High Geology	—	—	—	17.2	16.0	14.0

### Finding Rate Uncertainty

As the resource base is depleted, the remaining reservoirs become increasingly difficult to find.

The amount of petroleum found per exploratory foot drilled, the finding rate, diminishes as the resource base is depleted. For example, unless better interpretation methods are developed, geologic and geophysical information becomes harder to interpret, leading to more dry holes in new field exploratory drilling. Drilling efficiency, as measured by finding rates, also decreases with well depth and decreased reservoir size. The overall rate at which the efficiency diminishes is of critical importance in the midterm. Technological advances in geophysical data collection and analysis may slow the decrease in drilling efficiency.

In view of the long historical experience in exploring for oil and natural gas, one could assume that extrapolation from past experience to estimate future finding rates would be reliable. Finding rates, however, have fluctuated widely in the past.

Petroleum exploration tends to occur in plays: when oil or gas is discovered in a new area, drilling in that area intensifies, peaks, and later dies out. The rate at which new reserves are discovered per foot of drilling rises and falls as new plays begin and old plays die out. The initiation of new plays is governed by many factors, including the accumulation of geophysical and geological information and the availability of leases.

In addition, technology, prices, and regulatory environment can influence the division of drilling effort among competing prospects and thus indirectly affect the finding rate. Furthermore, the amount of recoverable resources is never known with certainty until production is complete. Estimates of proved reserves in previously discovered deposits are frequently adjusted, primarily on the basis of production history. These adjustments are reported as revisions, which may be either positive or negative.

Additional difficulties are associated with the reporting process itself. Reserves may not be reported at the time they are discovered. For example, oil reserves in Prudhoe Bay were reported in 1968, but the associated gas reserves were not reported until 1970. Also, incentives exist for operators not to report some wildcat drilling.

As a result of the above factors, the historical record of oil and gas discovery is difficult to interpret. The low level of oil and gas discoveries reported in the last decade, in particular, is a subject of much controversy.

This analysis is based on statistical regression over the history of drilling and discovery since the

1950's and assumes that finding rates decline in proportion to remaining undiscovered recoverable resources (using USGS estimates of original resources in place). The procedure leads to finding rates that are higher than those of the last decade and lower than those of earlier decades.

The effect of using the most recent year's finding rates was analyzed and produced a drop in liquids production of 880,000 barrels per day and a drop in natural gas production of 2.2 trillion cubic feet per year in 1990. Onshore crude oil production declined by 930,000 barrels per day, offshore crude oil production increased by 175,000 barrels per day, and natural gas production declined in all regions. For liquids, this difference was compensated for by an increase in imports.

The lower supply of natural gas resulted in significantly higher prices, both at the wellhead and delivered. Although the gas wellhead prices are still below the Btu-equivalent price of crude oil, they are sufficiently high to make Mexican gas imports competitive under the assumed pricing formula. Also, because wellhead prices for gas are closer to oil prices, the margin for incremental pricing is smaller, resulting in less pass on of incremental charges to industrial users. The extent of incremental pricing is still significant, however.

### **Drilling Cost Uncertainty**

Historically, drilling costs have been very sensitive to the balance between the supply and demand of drilling services. Although the response of drilling costs to the demand for drilling serves the useful purpose of allocating drilling services in an efficient manner, the resulting variations in the cost of drilling make it difficult to project those costs into the future. Also, as marginal drilling rigs are brought into production, rig productivity declines. A closely related uncertainty is the future availability of the various factors (such as drilling rigs, mud, tubular goods, and skilled manpower) that go into drilling.

## **ENERGY SUPPLY—COAL**

The United States increasingly turns to coal to meet its energy needs during the midterm, as a result of rapidly escalating prices for oil and natural gas and the depletion of domestic oil and gas resources. In 1978, the ratio of the delivered price of residual oil to the delivered price of coal

was 1.9; by 1995 this ratio increases to 2.9. This significant price advantage of coal over other fossil fuels, including the restrictions on oil and gas use imposed by the Powerplant and Industrial Fuel Use Act, are the primary reasons for the large penetration of coal in the midterm.

Coal is the most abundant energy resource in the United States and the U.S. coal reserve base is among the largest in the world. There are approximately 431 billion tons—the equivalent of 1666 billion barrels of oil—of demonstrated coal reserves in the contiguous United States and Alaska, compared to 61 billion barrels of demonstrated oil and gas reserves. In addition, less uncertainty is associated with these reserve estimates than is associated with other estimates of domestic energy resources. However, significant obstacles must be overcome in achieving more widespread use of coal. These obstacles include the use of coal in an environmentally acceptable manner, providing an adequate transportation system to move coal to domestic and export markets and ensuring that adequate production capacity is in place to satisfy rapidly growing demand.

## Coal Production

Coal production grows 6.0 percent yearly between 1978 and 1990, as derived from Table 4.26.

This rate, which is nearly 6 times the rate of growth in gross energy demand, represents a significant change from the slow growth in coal production that occurred prior to 1973. As a result, coal accounts for 30 percent of gross energy consumption in 1990 compared to 18 percent in 1978.

Coal production grows dramatically in the West and significantly in the East, as shown in Figure 4.18. By 1995, the West accounts for 47 percent of all U.S. coal production, compared to 25 percent in 1978. Most of this increased production takes place in the Northwest Great Plains region (Wyoming and Montana), where there exists vast reserves of low- and medium-sulfur subbituminous coal that is relatively inexpensive to mine. Production in this region increases about sixfold, reaching 560 million tons by 1995. These levels of western coal production imply a decrease in the average Btu content per ton of coal consumed in the future, because the bulk of the production in the West is subbituminous coal, and an increase in coal shipments from the West to coal markets in the East. In the East, coal expansions occur in Northern Appalachia and the Midwest. Midwest production alone increases 231 percent by 1995, causing increased consumption of high-sulfur bituminous coal, primarily by the electric utility industry. In the rest of the Appalachian region, production declines due to depletion effects and diseconomies

**Table 4.26 Coal Production by Region and Mining Method: History and Projections for Three Base Scenarios, 1965–1995**  
(Million Tons)

Region	Mining Method	History <sup>a</sup>			Projections								
		1965	1973	1978	1985			1990			1995		
					Low	Mid	High	Low	Mid	High	Low	Mid	High
East.....	Surface.....	168	235	269	266	266	266	138	139	139	78	78	78
	Deep.....	324	289	227	489	488	487	680	688	698	816	835	838
	Total <sup>b</sup> .....	492	524	496	755	754	753	818	826	837	894	913	917
West.....	Surface.....	11	57	154	348	347	348	440	468	467	624	726	725
	Deep.....	9	10	15	27	28	29	46	49	49	74	77	76
	Total <sup>b</sup> .....	20	68	169	375	376	376	487	517	516	698	802	801
National.....	Surface.....	189	298	427	614	613	614	579	607	606	702	803	803
	Deep.....	338	300	243	516	517	515	726	737	747	890	912	915
	Total <sup>b</sup> .....	527	599	670	1,129	1,130	1,129	1,305	1,343	1,353	1,592	1,715	1,718
Total Production (quadrillion Btu).		13.4	14.4	15.0	24.9	25.0	24.9	28.5	29.3	29.5	34.3	36.7	36.8

<sup>a</sup>Source of historical data is Volume 2 of the EIA *Annual Report to Congress*, 1979.

<sup>b</sup>Coal production includes only bituminous and lignite coal.

<sup>c</sup>The historical national total includes anthracite coal production, which is mined in the East, mostly in Pennsylvania.

Note: Data may not add to total shown due to independent rounding.

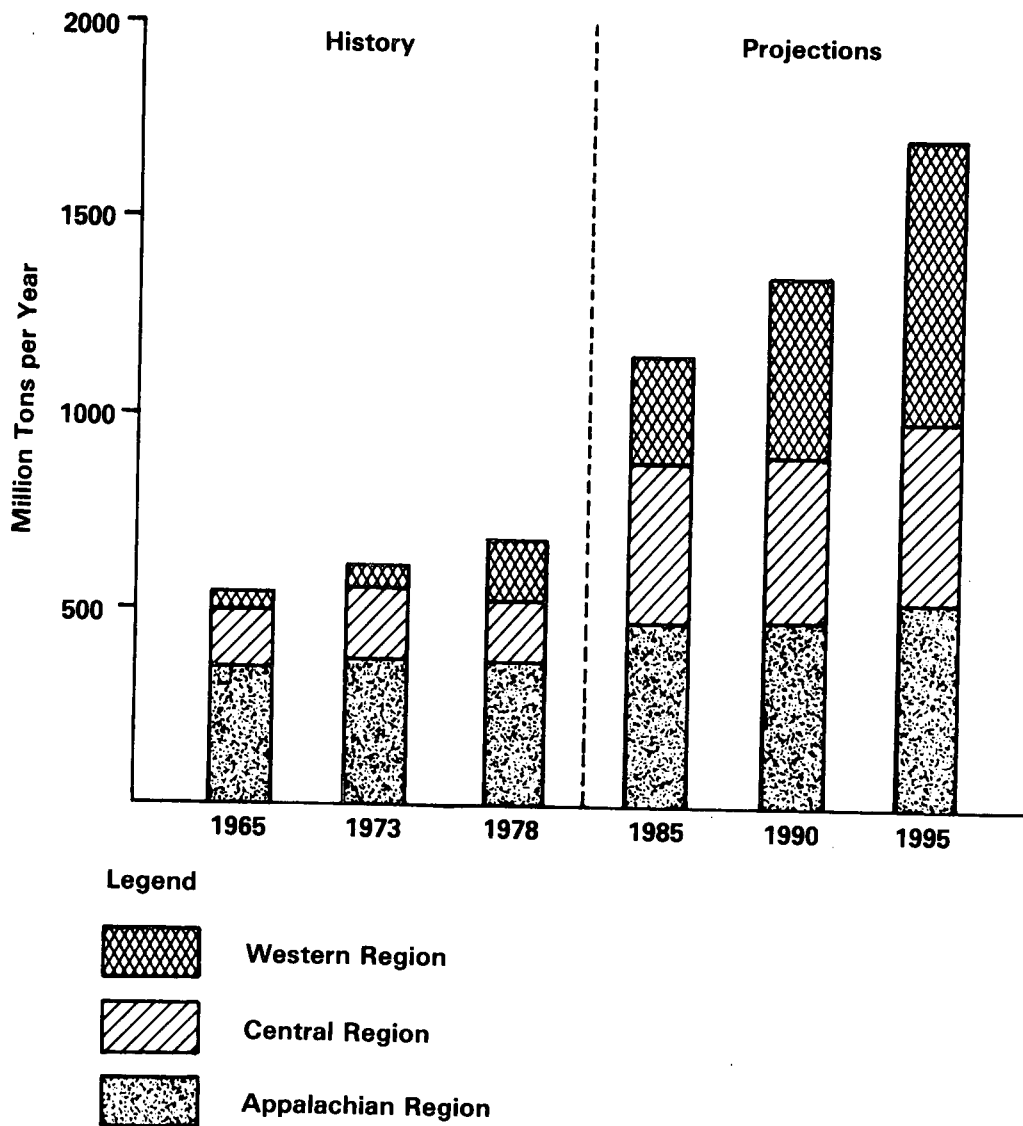

Figure 4.18 Production of Coal by Region

of production under the stringent land reclamation requirements imposed by the 1977 Surface Mining Control and Reclamation Act.

Coal production is relatively insensitive to the assumed price of foreign oil, because the economies associated with coal use are compelling even at the lowest projected world oil price. However, coal production in 1995 is over 120 million tons greater in the middle and high world oil price scenarios than in the low scenario. Medium-sulfur, subbituminous western coal accounts for much of this increase. This increased production satisfies additional requirements for coal-fired steam plants in the electric utility industry and allows a stronger

penetration of coal-based synthetic fuel technology.

The rapid growth in coal production could be limited by requirements to mine, transport, and consume coal in an environmentally acceptable manner and without undue risks to public health and safety. Mining of coal presents challenges in the areas of land disturbance, surface water contamination, and development of virgin lands, especially in the West. Existing mine safety and health legislation has been cited for significant declines in mine productivity and resulting higher prices for coal. Although these forecasts depend on the assumption that regulations would remain

constant, additional legislation or changes to existing regulations could adversely affect future productivity and result in higher prices.

Leasing of Federal lands in the West must be adequate to support the production forecasted, or significant changes in future coal production patterns and prices will occur. The projected production of coal requires increases in labor, equipment, and capital for investment in new mines. Skilled miners and mining engineers must be available to build and operate the new mines. In addition, mining equipment and mining technology must keep pace with the expansions in the West and the seams in the East, which are increasingly difficult to mine. In the East, local transportation of coal to the railhead becomes increasingly difficult as new mines open further away from existing rail lines. Investments in mine equipment for production, safety, and health will be required to support industry expansion.

The forecasted growth would require expansions in railroad capacity to move ever increasing quantities of coal, causing potential problems in both the East and the West. In the East, the existing rail system needs significant upgrading to handle the additional coal flows. In the West, new facilities will be required to move over 500 million tons of coal projected for the Northwest Great Plains by 1995. Concern exists about the railroads' ability to finance the required expansions and the rates that users will face for coal shipments. Escalation in coal shipping tariffs can significantly alter coal markets.

Increased transportation of coal increases noise pollution and air pollution in towns along the railroad's path. Significant capital expenditures are required if railroads must route lines around towns and build signaling and bypasses for local traffic.

The relative stability of coal prices over the forecast period largely motivates the shift of the domestic energy market toward coal. Between 1973 and 1978, the average national real price of coal increased rapidly, primarily because of the combined effects on mining production costs of mine safety and health legislation (MESA), water pollution regulations (promulgated under the Federal Water Pollution Control Act of 1972), lower labor productivity, and the gradual depletion of easily minable coal resources in the East. However, with a greater share of coal production coming from the West where coal production is less costly and no new health, safety, or environmental

regulations are assumed to be promulgated, the average price of coal in the midprice case (see Table 4.27) increases from \$1.06 in 1978 to only \$1.36 per million Btu by 1990. By contrast, the delivered price of residual oil increases from \$2.49 to \$6.22 per million Btu. The economies of low-sulfur, subbituminous western coal, which can be mined in very thick seams close to the surface, are even more dramatic because the minemouth price is only \$0.51 per million Btu throughout the forecast period. Even adding transportation costs, this coal is competitive in the midwestern and southwestern markets.

The price differential between high- and low-sulfur coal reflects the additional environmental control costs required to burn high-sulfur coal. Partly due to the increased stringency of the Revised New Source Performance Standards for sulfur dioxide, particulate, and nitrogen oxide emissions by electric utilities, the use of low sulfur coal by utilities gradually increases throughout the forecast period. From 29 percent of the total coal consumed by utilities in 1985, low-sulfur coal use increases to 38 percent by 1995. However, this relative increase in the use of low-sulfur coal by utilities varies substantially across regions, however, with midwestern and southwestern utilities (subbituminous, low-sulfur coal) accounting for most of the increase.

## Coal Consumption

The electric utility sector, which accounted for 77 percent of total U.S. coal consumption in 1978, continues to dominate coal consumption to 1995, as shown in Table 4.28. Although this share declines to 71 percent in 1995, the level of coal use by electric utilities increases by an amount nearly equal to the total domestic consumption of coal in 1978. This dramatic increase in coal use by utilities is influenced to a large degree by the restrictions on oil and gas use in new units imposed by the Powerplant and Industrial Fuel Use Act. Consequently, any relaxation of the provisions contained within the Act or any hesitancy on the part of existing oil and gas plants to convert to coal in spite of its economic advantage, could substantially reduce the rate at which coal use in the utility sector grows. This growth could further be dampened if more nuclear generating units are built than projected here. (See Table 4.17.)

**Table 4.27 Coal Prices by Region and Coal Type: History and Projections for Three Base Scenarios, 1965–1995**  
(1979 Dollars per Million Btu, FOB Mine)

Region	Coal Type by Rank and Sulfur Level <sup>b</sup>	History <sup>a</sup>			Projections								
		1965	1973	1978	1985			1990			1995		
					Low	Mid	High	Low	Mid	High	Low	Mid	High
Northern Appalachia.....	Bituminous/HS	—	—	—	1.33	1.33	1.33	1.47	1.47	1.50	1.61	1.61	1.62
Central Appalachia.....	Bituminous/LS	—	—	—	1.77	1.77	1.77	1.93	1.93	1.93	2.12	2.12	2.10
Midwest.....	Bituminous/HS	—	—	—	1.21	1.21	1.21	1.34	1.34	1.34	1.43	1.43	1.43
Great Plains.....	Subbituminous/LS	—	—	—	0.51	0.51	0.51	0.51	0.51	0.51	0.51	0.51	0.52
Rockies.....	Bituminous/LS	—	—	—	1.10	1.12	1.13	1.24	1.25	1.25	1.35	1.37	1.36
National Average.....	All Types	0.39	0.56	1.06	1.26	1.26	1.26	1.38	1.36	1.37	1.42	1.38	1.38

<sup>a</sup>Source for derived historical data is Volume 2 of the EIA *Annual Report to Congress*, 1979.

<sup>b</sup>LS denotes 0-0.67 pounds of sulfur per million Btu. HS denotes greater than 1.68 pounds per million Btu.

Notes: — indicates not available.

Coal prices for bituminous and lignite coal only.

**Table 4.28 Coal Consumption by End-Use Sector: History and Projections for Three Base Scenarios, 1965–1995**  
(Million Tons per Year)

Sector	History <sup>a</sup>			Projections								
	1965	1973	1978	1985			1990			1995		
				Low	Mid	High	Low	Mid	High	Low	Mid	High
Electric Utility.....	245	389	481	740	737	739	861	884	890	1,055	1,115	1,136
Industrial <sup>b</sup> .....	132	79	73	219	223	221	241	248	249	268	280	258
Synthetics.....	—	—	—	12	12	12	19	27	31	50	101	105
Domestic Coking.....	95	94	71	74	74	73	79	78	77	80	79	79
Total Domestic Consumption.....	472	563	625	1,045	1,046	1,045	1,199	1,237	1,247	1,452	1,575	1,577
Net Exports.....	52	54	38	85	85	85	108	108	108	143	143	143
Change in Stocks <sup>c</sup> .....	3	(18)	7	NA	NA	NA	NA	NA	NA	NA	NA	NA
Total Production.....	527	599	670	1,129	1,130	1,129	1,305	1,343	1,353	1,592	1,715	1,718
Total Btu (quadrillion).....	13.4	14.4	15.0	24.9	25.0	24.9	28.5	29.3	29.5	34.3	36.7	36.8

<sup>a</sup>Source of historical data is Volume 2 of the EIA *Annual Report to Congress*, 1979.

<sup>b</sup>Includes small amounts of coal used by the residential, commercial, and transportation sectors.

<sup>c</sup>Includes changes in stocks, imports, losses and unaccounted for.

Notes: NA indicates not applicable.

— indicates not available.

Coal consumption for bituminous, lignite, and anthracite coal.

Changes in the growth of electricity demand, regulations associated with PIFUA, implementation of the Revised New Source Performance Standards, and installations of new nuclear generating capacity all affect the coal consumption of electric utilities. Whereas environmental standards may affect the mix of coals consumed, the other uncertainties result in either increases or decreases in total coal consumption in the utilities sector. The ability of electric utilities to generate suffi-

cient capital to build additional coal-fired equipment depends on the responsiveness of public utility commissions and their willingness to permit the building of new, coal-fired generating capacity to replace expensive, existing, oil- and natural gas-fired steam equipment.

Industrial consumption of coal increases dramatically from 73 million tons in 1978 to 280 million tons in 1995. Much of this increase occurs early in the forecast period, as consumers convert

existing steam generators from oil and natural gas to coal. Coal is also the primary fuel for new boilers. Both of these projections result from the combined effects of rapidly escalating prices for refined oil products and natural gas and enforcement of the Powerplant and Industrial Fuel Use Act. Total coal use in the industrial (both process heat and boilers) sector grows at an annual rate of 10.7 percent between 1978 and 1990, while use of other fossil fuels declines. This rapid transition to coal is not significantly influenced by the world oil price, because even the lowest price projection for foreign oil is sufficiently high to encourage industrial decisionmakers to shift to coal. In both the electric utility and industrial sectors, the forecast coal penetration depends on how quickly capital changes are made to accommodate coal.

Finally, there exists considerable uncertainty in how rapidly consumers respond to higher oil and natural gas prices and switch from these fuels into coal. Consumption of coal in the industrial sector, for example, requires significantly greater capital expenditures than for other fuels, due to the land and equipment requirements for coal handling, coal storage, and pollution control. These costs, coupled with uncertainties about the economy and future governmental regulations, could easily slow down both the conversion of existing boilers to coal and the installation of new coal-fired boilers. In addition, uncertainties surrounding the implementation of the Natural Gas Policy Act, PIFUA, and the NSPS could slow the change to coal consumption in industrial steam generators.

Consumption of coal in direct combustion processes, such as steam boilers used in industry and electric utilities, results in emissions of particulates, sulfur oxide, nitrous oxide, and other contaminants. Environmental problems caused by these emissions as well as any difficulty in their control may restrict the use of coal. Uncertainties exist in both the standards that must be met for removal of these pollutants and the ability of the pollution control equipment to operate reliably and efficiently. Safeguards against climatological results such as acid rain and the "greenhouse effect" could slow the penetration of coal. Long-distance transport mechanisms for pollutants must be studied in order to determine how pollutants react to form acid rain and what safeguards will be needed to prevent further significant deleterious effects. The increased use of fossil fuels, especially coal, results in increased carbon dioxide levels in the upper atmosphere, as more heat from the earth is trapped by the carbon dioxide layers. This

"greenhouse effect" may constrain coal consumption patterns in the midterm.

A new market for coal also develops for synthetic fuels as production moves from the demonstration phase into commercial production, particularly in the 1990 to 1995 time horizon. Coal is used to produce medium-Btu gas in the Midwest and West and syncrude in the Northwest Great Plains by 1995. Coal use in synthetics grows from nearly zero in 1978 to about 100 million tons by 1995. Considerable uncertainty surrounds the development of the coal-based synthetic fuel industry, however, because the technologies are relatively new and their costs are uncertain.

During the midterm, the demand for coking coal grows only modestly, from 71 million tons in 1978 to 89 million tons by 1995, reflecting the relative stagnation of iron and steel production in the United States. Exports of coking coal and especially steam coal, however, are projected to increase to 143 million tons by 1995. U.S.-produced steam coal is expected to satisfy the increasing demands of both Western Europe and Japan over the next 15 years, as other sources available to those nations are either unable to satisfy the increased demand or are economically unattractive compared to U.S. coal.

## ENERGY-ECONOMY INTERACTIONS

As discussed earlier, macroeconomic activity substantially affects energy production and consumption within the United States. However, the opposite is also true. As an integral part of the U.S. economy, the energy sector both consumes the products produced by other sectors of the economy and produces products which are used as inputs into other production processes. On the demand side, this interaction between the energy sector and the rest of the economy affects the prices of goods and services produced in the United States and, thus, the demand for those goods and services. On the supply side, changes in the energy sector affect the productive capacity of the Nation.<sup>2</sup>

When the world price of a major energy resource, such as oil, changes, the price change is directly embodied in the prices of domestic and

<sup>2</sup> The results contained in the following sections are based on the use of the Data Resources, Inc. Macroeconomic Model of the U.S. economy. An alternative analysis currently under preparation by Edward Hudson and James Parrish using the Dynamic General Equilibrium Model is forthcoming.

imported goods and depends on the amount of energy used to produce these goods. Moreover, ripple effects from an initial price shock can persist in causing greater, or less, inflation even after the prices of all goods have been adjusted to reflect higher energy costs. The economy has certain built-in mechanisms, such as the tendency of wages, social security payments, and Government transfer payments to follow prices upward, that serve to transmit the initial shocks to later periods.

The depressing effect that higher prices have on aggregate demand leads to a lower growth rate for the economy. This effect is accentuated if total payments to foreign energy producers increase and the nominal trade balance deteriorates. These events, in turn, reduce both the purchasing power of the dollar and the total domestic production that is available for domestic consumption after foreign demand is satisfied. Conversely, if oil import payments decline as oil prices increase, the trade balance is positively affected and the purchasing power of the dollar increases.

In addition to depressing aggregate demand, higher world oil prices also reduce the effective stock of capital and, thus, affect the total productive capacity of the Nation; this latter occurrence in turn can lead to a permanently lower rate of growth in potential output.

### Key Macroeconomic Variables in the Middle World Oil Price Case

In the middle world oil price case, real GNP grows 2.6 percent annually from 1978 to 1995 or at approximately the same rate as between 1973 and 1978. (See Table 4.29.) Projected growth in real disposable income is comparable to that in real GNP. Between 1978 and 1995, industrial production increases at a higher rate (3.6 percent annually) than it did between 1973 and 1978 (2.5 percent annually); however, industrial production does not regain the strength that it exhibited between 1965 and 1973 when it grew at an annual rate of 4.7 percent.

Prices, as measured by the implicit price deflator for GNP, increase 6.9 percent annually from 1978 to 1995. The annual average unemployment rate projected for the 1978-95 period falls from a peak of 7.6 percent in 1981 to below 6.5 percent in 1986 and thereafter. Foreign and domestic new car sales average 12 million per year during 1985-95.

## Macroeconomic Interactions with Energy in the Three Projection Series

Throughout the midterm, world oil prices moderately affect income, output, and the general inflation rate and significantly affect the unemployment level.

### Price Effects

The growth rate of the producer price index for fuels and related products and power (the Bureau of Labor Statistics index of nominal energy prices at the wholesale level) varies between 1978 and 1995 from 15.4 percent in the high price case to 11.9 percent yearly in the low price case. This variation, which is most prevalent during the early years of the forecast, is reflected in the different values for producer prices, consumer prices, and the implicit GNP deflator shown in the table below:

Energy Price Effects on General Prices, 1978-95 World Oil Price

World Oil Price	Producer Price Index for Fuels and Related Products and Power	Producer Price Index	Consumer Price Index (CPI)	Implicit Price Deflator for GNP	(Annual Rates of Change)											
					High	Medium	Low	Low to Medium	Low to High							
					15.4	13.8	11.9	8.4	7.9	7.4	7.7	7.5	7.4	7.0	6.9	6.8
					(Inflation Rate Difference)											
					Low to Medium	Low to High		1.9	3.5	0.5	1.0	0.1	0.3	0.1	0.2	

Higher inflation rates are also accompanied by depressing effects on output and employment. Moreover, Government policies designed to neutralize employment effects of oil price changes would most likely accentuate the differences among the inflation rates for the three scenarios. That is, with a rapid rise in the world oil price, an attempt to maintain employment could add to the inflationary impetus from higher oil prices and in turn lead to higher price effects than those shown, for example, in the "High World Oil Price" case.



## Trade Balance Effects

The trade balance in the middle and low cases reflects a continuation of past trends with the total cost of energy imports rising throughout the forecast period (see the table below).

**Real Cost of Energy Imports at Forecast Import Prices<sup>3</sup>**  
(Billions of 1979 Dollars)

World Oil Price	1985	1990	1995
High	74	72	70
Medium	67	72	77
Low	66	80	99

In the low case, in which the real world oil price remains constant, the increase in the real import bill can be attributed entirely to the increasing quantity of energy imports between 1985 and 1995. (See Table 4.1.)

In the middle case, increases in the real world oil price more than offset a moderate decline in the quantity imported, again increasing the import bill. In the high price case, however, higher prices dampen the demand for energy imports to such an extent that the import bill in real terms actually declines over time.

In 1985, the import bill is largest in the high case. By 1990, however, higher energy prices have reduced imports to the extent that the energy imports bill in the high case is below that of the low case. This trend continues thereafter, so that, by 1995, the import bill for the high case is smaller than that of the medium case in real terms, while the import bill of the low case is the largest of the three.

This behavior of oil imports toward the end of the forecast period in the high case in the later years tends to spur domestic demand and reduce an otherwise negative impact of higher world oil prices. Conversely, the higher import bill in the low case tends to blunt an otherwise positive effect on the economy of lower energy prices.

<sup>3</sup> The figure presented for real cost of imports is not the same as a conventionally calculated "real imports" value which reflects only quantity variations (i.e., the quantities multiplied by constant 1979 prices of energy imports were not used). Rather, it reflects variations in both quantities and in "real prices," which have been converted from the MEMM model base year of 1975 to 1979 dollars by reflecting the change in the implicit GNP deflator between 1975 and 1979.

## Effects on Potential GNP

The change in energy prices across the three cases facilitates variations in total energy consumption from the low to high case by approximately 3.1 percent in 1985, 5.1 percent in 1990, and 7.0 percent in 1995. Accompanying this variation in energy consumption is a related variation in the productive potential of the economy. This variation in productive potential across the three scenarios, as measured by an index of potential output (potential GNP), is summarized below:

**Effects of Oil Prices on Energy Consumption and Other Supply-Side Variables**  
(Percentage Change from Low Price Case to High Price Case)

	Total Energy Consumption	Potential GNP	Capital Stock	Labor Force
1985	-3.1	-0.2	-1.4	-0.1
1990	-5.1	-0.7	-2.8	-0.1
1995	-7.0	-1.2	-3.7	-0.1

The potential output index measures the productive capacity of the economy provided that three basic productive factors—capital, labor, and energy—are applied to their maximum capacity. Because of factor substitution, this index of overall productive capacity crudely approximates variations in actual productive capacities at the industry level; however, the index does provide some estimate as to the sensitivity of the national production capability to changes in the energy market. Although it is not apparent from the table, the direct effect of energy prices on the effective productive capacity of the Nation is small. Most of the change in potential GNP can be attributed to both variations in investment activity and the growth of the effective capital stock. However, these variations are strongly influenced by changes in the energy market and its resulting effect on the general economy. Thus, by its effect on the growth of the effective capital stock, the price and availability of energy is an important determinant of aggregate national productive capacity.

In the long run, these cumulative changes in the capital stock have a greater effect upon economic growth than do the short-run changes in aggregate demand. Thus, the difference in economic impacts among the three scenarios increases over time for two reasons: (1) the difference in oil prices

**Table 4.29 Selected Macroeconomic Variables: 1965-1979 Historical and Final Values for Three Base Scenario Projections, 1985-1995<sup>a</sup>**

	History				Projections								
	1965	1973	1978	1979	1985			1990			1995		
					Low	Mid	High	Low	Mid	High	Low	Mid	High
World Oil Price (1979 dollars per barrel)	6.00	6.50	15.50		27.00	32.00	39.00	27.00	37.00	44.00	27.00	41.00	56.00
<b>Macroeconomic Variables</b>													
Real Gross National Product (billion 1979 dollars)	1,533	2,044	2,314	2,369	2,734	2,718	2,696	3,209	3,159	3,116	3,650	3,569	3,501
Real Disposable Per Capita Income (thousand 1979 dollars per person)	5.2	6.7	7.3	7.4	8.1	8.1	8.0	9.0	9.0	8.9	9.9	9.8	9.7
Compound Annual Rate of Growth in Real GNP (to/from 1978)	3.2	2.5	NA	2.3	2.4	2.3	2.2	2.8	2.6	2.5	2.7	2.6	2.5
Unemployment Rate, All Civilian Workers (percent)	4.5	4.9	6.0	5.8	7.0	7.1	7.4	5.6	6.0	6.4	5.3	5.9	6.4
Production Index for Manufacturing (1967 = 1.00)	0.90	1.30	1.47	1.53	1.87	1.86	1.84	2.34	2.28	2.24	2.72	2.66	2.61
Implicit Price Deflator for GNP (1972 = 1.00)	0.74	1.06	1.52	1.66	2.61	2.64	2.69	3.55	3.64	3.70	4.65	4.73	4.81
Rate of Increase in the Consumer Price Index (to/from 1978)	5.8	8.0	NA	11.3	8.6	8.8	9.2	7.8	8.1	8.3	7.4	7.5	7.7
Average Yield, New High-Grade Corporate Bonds (percent)	4.5	7.7	8.9	9.9	10.0	10.0	10.1	8.8	8.8	8.5	9.3	8.7	8.4
Population, Non-Institutional (millions of persons) <sup>b</sup>	194	210	218	220	232	232	232	243	243	243	251	251	251
<b>Energy Variables</b>													
Unit Value Index of U.S. Imports, Fuels and Lubricants (1967 = 1.00)	0.97	1.44	5.74	8.09	19.5	23.2	28.1	26.9	36.5	44.9	35.6	53.2	73.9
U.S. Imports of Fuels and Lubricants (billion 1967 dollars) <sup>c</sup>	2.27	5.73	7.48	7.56	6.44	5.54	5.05	7.81	5.31	4.38	9.74	5.34	3.61
Wholesale Price Index, Fuels and Related Products, and Power (1967 = 1.00)	0.95	1.34	3.23	4.08	10.8	12.2	14.2	15.9	19.9	23.1	21.7	28.9	37.0
Total Gross Energy Consumption (quadrillion Btu)	53.0	74.5	78.0	78.0	83.1	81.4	80.5	92.4	88.9	87.7	101.3	96.3	94.2
Energy/GNP Ratio (thousand Btu per 1979 GNP dollar)	34.6	36.4	33.7	32.9	30.4	29.9	29.9	28.8	28.2	28.1	27.7	27.0	26.9

<sup>a</sup>The statistics presented here represent the final result of iterations between EIA's energy models and the DRI macroeconomic model of the U.S. economy. Macroeconomic values underlying all energy projections stem from one iteration earlier than the values shown here. The values here represent the best estimate of macroeconomic impacts of projected energy values.

<sup>b</sup>Population values are assumed constant over all scenarios.

<sup>c</sup>As a model input, U.S. Imports of Fuels and Lubricants are given in the units used in the DRI model, that is, billions of constant 1967 dollars.

Notes: Source of historical data is *Data Research Incorporated Energy Review*, Winter 1980 and Volume 2 of the *EIA Annual Report to Congress*, 1979. NA indicates not applicable.

grows over time and (2) cumulative effects on the capital stock cause the difference in national productive capacity to grow.

### Macroeconomic Impacts in the Three Projection Series

The macroeconomic impact projections summarized in this section and in Table 4.29 suggest several important points:

- Energy, although a small component of total output in recent years, is currently attaining

increasing importance as a determinant of the overall economic picture.

- As the energy/GNP ratio declines over time, because of increased conservation efforts and improved energy efficiency, fewer opportunities remain for reducing energy consumption without adverse economic effects.
- The future price and availability of imported oil, both of greater uncertainty this year than ever before, are variables of great importance to the U.S. economic future.

## COMPARISON TO FORECASTS IN PREVIOUS EIA ANNUAL REPORTS AND ELSEWHERE

This midterm forecast is the third annual forecast presented in the Energy Information Administration (EIA) *Annual Report to Congress*. Each of these forecasts has differed to some extent from its predecessors and from other projections prepared by other forecasters. The fact that these forecasts differ from each other should not be surprising; as time progresses, new data become available, analytical procedures change, and new factors, such as price trends and legislation, are perceived in the energy market place which cause the assumptions on which the forecasts are based to change. In addition, assumptions and approaches used by other forecasters may be different from the outset.

A comparison of different forecasts should provide assurance that differences in forecasts are explicable in terms of the different data, approaches, or assumptions used. Differences between forecasts also provide a measure of the uncertainty associated with forecasting.

Four external forecasts were selected for comparison with the aggregate EIA results. In addition, other, more specialized forecasts were used in some specific supply comparisons. The four forecasts are:

- The middle energy price increase and low economic growth case from the recent National Research Council Study, *Energy in Transition 1985-2010*, also known as the CONAES Study (Committee on Nuclear and Alternative Energy Systems)
- The December 1979 energy forecasts from the Exxon Corporation
- The Winter 1980 energy forecast from Data Resources, Incorporated (DRI)
- The October 1979 energy forecast from the Pace Company.

Of these, only the DRI forecast is sufficiently recent to include the increases in the world price of oil experienced late in 1979. In addition, the CONAES forecast predates the accident at Three Mile Island. These limitations should be considered together with the fundamental problem that definitions, assumptions, and analytical techniques may differ greatly. In common with the EIA forecasts, all four of these studies were prepared under the assumption that current and pending

Government policies would continue. Other forecasts, such as the Council on Environmental Quality study and the Harvard Energy Study that are premised on substantial policy changes, have not been included in these comparisons.

## Comparison of Total Energy Balance

With each successive forecast, the present one included, EIA has reduced the estimate of total energy supply for 1990, which is the one year for which comparisons are possible. In the 1977 *Annual Report*, scenarios most comparable to this year's scenarios projected a total supply of 106.6 to 109 quadrillion Btu per year. (See Table 4.30.) By 1978, the estimates had fallen to 97 to 105 quadrillion Btu per year, whereas current estimates range between 88 and 93 quadrillion Btu yearly. The reduction from the 1977 forecast to the 1978 forecast is largely attributable to the assumptions of lower economic growth that were made in 1978. In addition, the greater reduction that occurred between the 1978 forecast and the current forecast is partially a result of further reduction in the estimate of the future economic growth rate and partially related to much higher oil import prices. Table 4.32 illustrates this latter effect by showing that crude oil prices were roughly equal for the 1977 and 1978 forecasts but range to much higher values in the current forecasts.

Since the 1978 forecast of 22 to 26 quadrillion Btu per year, EIA has significantly reduced its forecast, within the total balance, of domestic oil production to between 18 and 20 quadrillion Btu per year. Estimates of domestic natural gas production have increased, rising by 1 to 2 quadrillion Btu per year since 1977; these increases are due to the estimated impact of deregulation and higher oil price. Estimates of electricity generation have decreased. The estimates of nuclear contribution have declined more than 1 quadrillion Btu per year between each adjacent pair of EIA forecasts. Nonetheless, all of the EIA projections forecast higher nuclear capacity.

Comparison of projected oil import levels shows progressive decreases, falling from a range of 20 to 29 quadrillion Btu per year forecast in 1977, to between 8 and 25 in the 1978 forecast, and 9.5 and 17 in the current forecast. These decreases result mainly from revised assumptions about lower economic growth and higher prices.

**Table 4.30 U.S. Energy Supply: 1977, 1978, and 1979 Annual Report Projections for 1990**  
(Quadrillion Btu per Year, 1979 Dollars)

	1978 Actual	1990 Projections								
		1977 Annual Report		1978 Annual Report			1979 Annual Report			
		Series C	Series F	C Low	C Middle	C High	C Low	C Middle	C High	
World Oil Price (dollars per barrel)	15.50	17.00	27.00	16.00	20.00	26.00	27.00	37.00	44.00	
<b>Domestic Energy Supply</b>										
Oil	20.7	20.1	23.5	21.9	23.1	25.8	18.1	19.6	20.3	
Gas	19.5	16.7	17.4	16.7	17.4	18.3	18.3	18.7	18.7	
Coal	15.0	27.5	29.4	28.7	31.2	33.6	28.5	29.3	29.5	
Nuclear	3.0	10.3	10.4	9.5	9.4	9.5	8.1	8.2	8.1	
Other	3.0	5.0	5.0	3.5	3.5	3.5	3.6	3.7	3.6	
Subtotal, Domestic Production	61.2	79.6	85.7	80.3	84.6	90.7	76.7	79.5	80.3	
Oil Imports	17.1	28.8	20.5	24.5	17.0	7.8	17.0	11.7	9.5	
Gas Imports	0.9	2.6	2.5	2.1	2.0	0.95	1.8	0.8	0.8	
Coal Imports	-0.9	-2.1	-2.1	-2.1	-2.1	-2.1	-2.7	-2.7	-2.7	
Subtotal, Net Imports	17.2	29.3	20.9	24.5	16.9	6.65	16.1	9.8	7.6	
Total Supply	78.4	108.9	106.6	104.8	101.5	97.3	92.8	89.3	87.9	
<b>Supply Prices</b>										
Grude Oil (dollars per barrel)										
Domestic (wellhead)	9.80	15.32	22.76	15.54	18.92	24.33	26.29	35.71	43.14	
Imported-Landed U.S.	15.86	16.71	27.21	16.36	20.15	25.66	27.00	36.54	44.07	
Average Refinery Acquisition Cost	13.57	16.17	24.87	16.18	19.78	25.31	26.89	36.40	43.88	
Natural Gas (dollars per million Btu)										
Marginal Price Southwest	2.19	2.56	2.43	2.41	2.62	2.82	3.43	3.68	3.40	
Coal (mine entrance, dollars per ton)										
High-Sulfur Bituminous, Northern Appalachia	NA	27.63	28.26	31.34	32.49	33.72	34.92	34.92	35.79	
Low-Sulfur Subbituminous, Northwestern Great Plains	NA	10.20	10.80	10.40	10.40	10.40	9.40	9.40	9.40	
Rate of Growth in Real GNP <sup>a</sup>	NA	3.70	NA	3.60	3.50	3.40	2.80	2.60	2.50	

<sup>a</sup>Data represents compound rate growth in real GNP from the years preceding the date of the Annual Report to 1990.

Comparison with the DRI forecast is of some interest because it is the only other forecast to include the recent oil price increases. Its total energy supply case for \$44 per barrel oil in 1990 is within 1 quadrillion Btu per year of EIA's comparable case. However, within the detailed breakdown of supply, larger differences occur. (See Table 4.31.)

As Table 4.31 also shows, the Pace Study, with a lower oil price, projects a 6 quadrillion Btu per year higher supply than the comparable EIA case. However, the Exxon and CONAES studies, with lower oil prices, project lower supply. The reasons for the differences are not immediately obvious. Although the Exxon study projects only 15 quadrillion Btu per year of domestic oil supply, all the other studies are in the 18 to 21 quadrillion Btu annual range. Both the Pace and Exxon forecasts project substantially higher oil import levels than do the other forecasts, although this may be

partially a result of their assumptions of lower oil prices.

## Demand

Because of higher energy prices and lower GNP growth, projected total energy consumption is 5 quadrillion Btu lower in the current medium forecast than in last year's "C-High" forecast. Most of the reduction, 4 quadrillion Btu, is in the industrial sector. Table 4.32 details this comparison.

Comparison of EIA demand estimates with estimates from the other forecasts is complicated by differences in sectoral definitions and methods of accounting. Table 4.33 presents a summary of the EIA midprice case as well as the other three forecasts.

The current industrial sector forecasts are considerably different from those appearing in the

**Table 4.31 Comparison with Other Projections of 1990**

	1978 Actual	1990 Projections								
		1979 Annual Report			Other Recent Projections					
		Low	Mid	High	CONAES <sup>a</sup>			National Commit- ment		
					Business As Usual	Enhanced Supply	DRI <sup>b</sup>		Pace <sup>c</sup>	Exxon <sup>d</sup>
World Oil Price (dollars per barrel)	15.50	27.00	37.00	44.00						
<b>Domestic Energy Production</b>										
Oil .....	20.7	18.1	19.6	20.3	18.9	18.7	15.0	16.0	20.0	21.0
Natural Gas .....	19.5	18.3	18.7	18.7	17.5	17.8	15.9	10.3	15.8	18.0
Coal .....	15.0	28.5	29.3	29.5	24.6	23.0	23.9	25.0	26.6	32.5
Nuclear .....	3.0	8.1	8.2	8.1	8.0	7.6	8.5	10.0	13.0	12.0
Other .....	3.0	3.7	3.7	3.7	—	4.9	3.8	4.4	7.1	11.6
Subtotal, Domestic Production .....	61.2	76.7	79.4	80.3	—	72.0	86.8	65.7	82.5	95.1
Oil Imports .....	17.1	17.0	11.7	9.5	10.6	17.8	19.7	—	—	—
Gas Imports .....	0.9	1.8	0.8	0.8	2.1	2.0	2.7	3.7	5.0	6.3
Coal Imports .....	-0.9	-2.8	-2.7	-2.7	-2.1	—	—	—	—	—
Subtotal, Net Imports .....	17.2	16.0	9.8	7.6	10.6	—	—	—	—	—
Total Supply .....	78.4	92.7	89.1	87.9	—	—	—	—	—	—
<b>Supply Prices</b>										
Crude Oil (dollars per barrel)										
Domestic (wellhead) .....	9.80	26.29	35.71	43.14	41.4	27.88	—	—	—	—
Imported-Landed U.S. ....	15.86	27.01	36.56	44.09	42.8	—	—	—	—	—
Average Refinery Acquisition Cost ..	13.57	26.89	36.40	43.88	42.4	27.85	—	—	—	—
Natural Gas (dollars per million Btu)										
Marginal Price Southwest .....	2.19	3.43	3.68	3.40	—	—	—	—	—	—
Coal (mine entrance, dollars per ton)										
High-Sulfur Bituminous, Northern										
Appalachia .....	NA	34.92	34.92	35.79	—	—	—	—	—	—
Low-Sulfur Subbituminous, Northwest										
Great Plains .....	NA	9.40	9.40	9.40	—	—	—	—	—	—
Rate of Growth in Real GNP from 1978 to 1990 .....										
	NA	2.8	2.6	2.5	2.7	—	—	—	—	—

<sup>a</sup>National Academy of Sciences, Committee on Nuclear and Alternative Energy Systems (CONAES), *Energy In Transition 1985-2010*, December 1979.

<sup>b</sup>Data Resources, Inc., *Energy Review*, Spring 1980.

<sup>c</sup>The Pace Company Consultants and Engineers, Inc., *The Pace Energy and Petrochemical Outlook to 2000*, October 1979.

<sup>d</sup>Exxon Company, U.S.A., *Energy Outlook 1980-2000*, December 1979.

Note: — indicates not available.

1977 Annual Report to Congress. Total projected energy use in 1990 is 2.5 percent lower and projected prices are 28 percent higher; shifts in the projected fuel mix are equally significant. As discussed earlier, the most pronounced feature of the current industrial forecasts is the rapid decline of residual and distillate fuel oil as major industrial fuels. Such a decline was not projected in the 1977 Annual Report—a forecast that was made with lower oil prices and before the Powerplant and Industrial Fuel Use Act of 1978. In that report, the combined 1990 share of residual and distillate fuel oil was over 11 percent. This year that share is projected to be less than 2 percent.

As compared to the 1978 forecast, this year's

Annual Report discusses several factors that cause both the increase in coal consumption and the decrease in gas consumption in the industrial sector forecast. These include the industrial sector model used, the change of the substitute fuel price cap imposed by the NGPA for natural gas from distillate to residual fuel oil, and the higher oil prices and different representation of the PIFUA. New industrial boiler capital costs favor coal consumption compared to oil and gas consumption.

Because of high oil prices, the representation of the PIFUA is more stringent than that used for the 1978 Annual Report—it forces more boilers to use coal than would otherwise use oil or gas. Thus, this year, although natural gas is priced as if it

**Table 4.32 Comparison of 1977, 1978 and 1979 Annual Report Forecasts for 1990**  
(Quadrillion Btu per Year and 1979 Dollars per Million Btu)

	1978 Actual	Projections							
		1977 Annual Report		1978 Annual Report			1979 Annual Report		
		Series C 17.00	Series F 27.00	C Low 16.00	C Middle 20.00	C High 26.00	Low 27.00	Middle 37.00	High 44.00
World Oil Price (dollars per barrel)	15.50								
<b>Sector Quantities</b>									
Residential/Commercial Sector	17.5	20.9	19.2	18.7	19.2	18.6	18.3	19.0	18.0
Electricity	4.1	6.2	6.4	6.6	6.4	6.3	5.4	5.4	5.4
Refined Petroleum Products	5.5	7.9	6.7	4.1	5.0	4.4	5.2	5.9	4.7
Natural Gas	7.6	6.8	6.1	8.0	7.8	7.8	7.4	7.4	7.6
Coal	0.3	0.02	0.02	0.06	0.05	0.1	0.3	0.3	0.3
Industrial Sector	22.0	36.4	35.6	33.8	32.8	31.1	27.9	26.7	26.2
Electricity	2.7	5.2	5.2	5.0	5.0	5.0	4.5	4.6	4.6
Refined Petroleum Products <sup>a</sup>	3.5	5.7	5.4	6.1	3.7	2.6	1.4	1.2	1.1
Natural Gas <sup>b</sup>	7.9	10.1	11.1	9.2	10.0	9.6	8.7	7.7	7.5
Coal	3.4	5.7	5.3	5.8	6.6	6.7	7.1	7.2	7.2
Other <sup>c</sup>	4.5	8.7	8.6	7.7	7.5	7.2	6.2	6.0	5.8
Transportation Sector	19.2	22.9	22.3	22.3	21.4	19.7	20.9	18.8	18.1
Fuel Oil	2.6	3.3	3.1	5.8	5.6	5.3	5.2	4.9	4.7
Gasoline	14.5	17.2	16.9	13.9	13.2	12.0	12.2	11.4	10.4
Jet Fuel	2.1	2.4	2.3	2.6	2.6	2.4	3.5	2.5	3.0
Total End-Use Quantity	58.7	80.2	77.1	74.8	73.4	69.4	67.0	64.5	62.4
<b>Sector Prices</b>									
Residential/Sector	5.11	6.64	7.64	6.83	7.16	7.51	8.37	8.80	9.06
Electricity	12.75	13.08	12.73	13.58	13.88	14.11	16.22	16.5	16.70
Refined Petroleum Products	3.45	4.44	6.50	4.24	4.96	6.10	6.49	8.30	10.00
Natural Gas	2.50	4.10	4.88	4.03	4.20	4.24	4.86	4.65	4.40
Coal	1.34	2.09	2.13	1.98	2.02	2.07	1.89	1.89	1.90
Industrial Sector	2.98	4.62	5.33	4.36	4.59	4.93	5.40	5.82	5.97
Electricity	8.34	10.64	11.67	9.85	10.13	10.32	11.88	12.18	12.26
Refined Petroleum Products	3.17	3.92	5.79	3.75	4.36	5.37	5.30	7.41	8.95
Natural Gas	1.56	3.16	3.44	3.08	3.40	3.21	4.06	4.85	4.91
Coal	1.34	2.01	2.05	1.96	2.01	2.33	2.24	2.26	2.28
Transportation Sector	4.94	6.27	7.88	6.47	7.15	8.13	8.43	10.33	11.62
Fuel Oil	3.61	4.45	5.95	4.27	4.66	5.59	8.88	9.97	8.60
Gasoline	5.64	6.69	8.31	7.42	8.26	9.34	9.82	11.86	13.17
Jet Fuel	3.60	4.80	6.39	4.61	5.08	6.64	6.54	8.12	9.87
Average End-Use Price	4.57	5.66	6.77	5.70	6.11	6.67	7.11	8.01	8.56

<sup>a</sup>Includes distillate and residual fuel oils, liquid gas, and refinery consumption of distillate and residual fuel oils.

<sup>b</sup>Includes refinery natural gas consumption.

<sup>c</sup>Includes feedstocks and raw materials, and refinery consumption of still gas and oil.

were residual oil instead of distillate oil in the economic test imposed by the PIFUA, residual oil is so expensive that fewer natural gas plants pass the test.

Two opposing changes affect the substitute fuel cap: this year it is based on lower priced residual oil rather than distillate oil, but the level of oil prices is higher. In addition, the higher gas demand in the utility sector also raises the industrial gas price. The net effect of these changes is higher natural gas prices and lower demand.

Little variation is present among the external industrial sector forecasts. The DRI forecast is somewhat lower than the other forecasts. If generation losses are excluded, however, the differences are somewhat smaller. Among the three

studies that showed a breakdown of energy type, the EIA forecast shows the highest use of electricity. In addition, the EIA analysis shows greater coal use combined with a lower oil use.

With the exception of jet fuel, only minor changes have occurred between the 1978 and 1979 *Annual Reports* with respect to comparable oil price cases in the transportation sector. Significant oil price increases combined with higher automobile efficiency cause the slightly lower total consumption. Projected consumption of jet fuel is higher than was forecast last year because of changes in the forecasting methodology.

The range of variation among external residential and commercial forecasts is quite large. In general, this is because of different assumptions

**Table 4.33 Comparison of 1977, 1978 and 1979 Annual Report Forecasts for 1990**  
(Quadrillion Btu per Year and 1979 Dollars per Million Btu)

	1978 Actual	1990 Projections					
		1979 Annual Report			Other Recent Projections		
		Low 27.00	Mid 37.00	High 44.00	DRI <sup>a</sup>	Pace <sup>b</sup>	Exxon <sup>c</sup>
World Oil Price (dollars per barrel)	15.50						
<b>Sector Quantities</b>							
Residential/Commercial Sector	17.5	18.3	19.0	18.0	21.7	21.4	32.0
Electricity	4.1	5.4	5.4	5.4	6.0	6.5	—
Refined Petroleum Products	5.5	5.2	5.9	4.7	6.0	6.9	—
Natural Gas	7.6	7.4	7.4	7.6	9.4	7.9	—
Coal	0.3	0.3	0.3	0.3	0.3	0.1	—
Industrial Sector	22.0	27.9	26.7	26.3	24.8	26.0	31.4
Electricity	2.7	4.5	4.6	4.6	3.6	4.2	—
Refined Petroleum Products	13.5	11.4	11.2	11.1	13.4	18.5	—
Natural Gas	7.9	7.7	7.7	7.5	8.2	7.5	—
Coal	3.4	7.1	7.2	7.2	5.0	5.8	—
Other	4.5	6.2	6.0	6.5	4.4	3.8	NA
Transportation Sector	19.2	20.9	18.8	18.1	19.5	22.0	19.9
Fuel Oil	2.6	5.2	4.9	4.7	5.0	6.0	—
Gasoline	14.5	12.2	11.4	10.4	10.1	12.0	—
Jet Fuel	2.1	3.5	2.5	3.0	4.0	4.0	—
Total End-Use Quantity	58.7	67.0	64.5	62.4	66.0	69.4	83.3
<b>Sector Prices</b>							
Residential/Sector	—	—	—	—	—	—	—
Electricity	12.75	16.22	16.56	16.70	17.45	—	—
Natural Gas	2.50	4.86	4.65	4.40	8.05	—	—
Industrial Sector	—	—	—	—	—	—	—
Electricity	8.34	11.88	12.18	12.26	15.18	—	—
Natural Gas	1.56	4.06	4.85	4.91	7.05	—	—
Transportation Sector	—	—	—	—	—	—	—
Gasoline	5.64	7.82	11.86	13.17	11.84	—	—
Jet Fuel	3.60	6.54	8.12	7.87	8.28	—	—

<sup>a</sup>Data Resources, Inc., *Energy Review*, Winter 1980.

<sup>b</sup>The Pace Company Consultants and Engineers, Inc., *The Pace Energy and Petrochemical Outlook to 2000*, October 1975.

<sup>c</sup>Exxon Company, U.S.A., *Energy Outlook 1980-2000*, December 1979.

<sup>d</sup>Includes distillate and residual fuel oils, liquid gas, and refinery consumption of distillate and residual fuel oils.

<sup>e</sup>Includes gasoline, jet fuel, distillate, residual, liquefied gases, kerosene, still gas and petroleum coke.

<sup>f</sup>Includes gasoline, naphtha, kerosene, diesel, residual, residual products, and other.

<sup>g</sup>Includes feedstocks and raw materials and refinery consumption of still gas and oil.

<sup>h</sup>Includes the following listed as raw materials: petroleum coke, asphalt and road oil, special naphthas and petrochemicals.

<sup>i</sup>Includes petrochemicals.

Note: — indicates not available.

NA indicates not applicable.

concerning how well and how rapidly this sector, especially the residential part, responds to market forces. The lowest forecast, CONAES, assumes that decisions on new residential fuel use are based on life cycle costing. The CONAES result is in close agreement with the Exxon forecast. The EIA forecast is close to CONAES and Exxon, but the closeness to CONAES is deceiving because EIA assumes much higher energy prices. Both DRI and Pace are much higher, mostly because of increased electricity use.

In the residential and commercial sectors, the projected total energy use for both the absolute levels and the growth rates in the 1979 *Annual Report* are very similar to the projections in the 1978 *Annual Report*. However, the fuel mix differs because of changes in the database, on which these

projections are based, the methodology in projecting demand for asphalt, and higher energy prices.

Petroleum consumption for 1990 in the residential and commercial sectors is higher in the 1979 *Annual Report* than in the 1978 *Annual Report* despite higher oil prices. The primary reason for this is that significantly larger amounts of liquid gas have been included in the residential sector database. A different methodology results in greater growth in commercial asphalt consumption. The secondary reason for increased petroleum consumption is that electricity and natural gas prices are significantly higher than last year.

Projected electricity consumption is lower in the 1979 *Annual Report* as a result of higher prices and demand management programs. This reduction more than offsets the increase in the rate of

penetration of electricity in the residential sector, resulting from more new homes with electric space heating systems.

## Electric Utilities

The 1979 *Annual Report* projects lower electricity generation than does the 1978 "C-High" case because of the lower forecasted economic growth. (See Table 4.34.) As a result, coal-fired generation declines and is combined with lower estimates of available nuclear capacity. However, nuclear plants provide about 23 percent of total electricity in both forecasts.

The 1979 *Annual Report* projection for coal-fired generation in 1990 shows a dramatic decrease from the 1978 *Annual Report* forecast. The 1978 *Annual Report* assumed that no limits existed for constructing new coal-fired capacity by 1990. In contrast, the 1979 *Annual Report* assumptions limit the construction of new coal-fired plants between 1985 and 1990. To compensate for some of this decrease in the available capacity, existing oil- and gas-fired plants are forecast to produce more

electricity. Natural gas plants are used more heavily, because the 1979 *Annual Report* is based on the assumption that the Economic Regulatory Administration will grant unlimited PIFUA exemptions rather than restrict gas consumption to 20 percent of the 1978 level. Oil consumption also increases, because the retirement and replacement of existing oil-fired capacity by new coal-fired plants occurs at a slower rate than in the 1979 *Annual Report*.

Projections of total generation in the National Electric Reliability Council (NERC) and Electric Power Research Institute (EPRI) forecasts are 300 to 600 billion kilowatt hours higher than those in this *Annual Report*, largely because demand projections vary because of higher economic growth assumptions.

The EPRI forecasts 4.7 percent annual growth in electricity from 1977 to 2000 for the base case; this is compared to the 3.2 percent growth rate from 1979 to 1990 that is forecast in this report. Care must be used in comparing growth rates over different periods. The earlier EPRI study projects 191 gigawatts of nuclear capacity in 1990. The 1979 *Annual Report* projects only 125 gigawatts of

**Table 4.34 Electricity Generation by Type of Fuel: Comparison with Other Projections for 1990**  
(Billion Kilowatt-Hours)

Fuel Type	Projections						
	1978 Actual	1990			1988		
		1979 Annual Report Middle	1978 Annual Report C-High	EPRI <sup>a</sup>	DRI <sup>b</sup>	Pace <sup>c</sup>	EEl/ NERC <sup>d</sup>
<b>Fossil Fuels</b>							
Oil .....	365	122	43	*300	127	*671.6	447
Natural Gas .....	305	247	54		204		120
Coal .....	976	1,786	2,407	1,900	1,733	1,622.6	1,727
Subtotal .....	1,646	2,155	2,504	2,200	2,064	*2,341.1	2,294
Nuclear .....	276	709	829	1,240	745	757.3	959
Hydroelectric .....	280	325	314	450	294	396.7	265
New Technologies .....	3	41	34	—	12	17.5	25
<b>Total Generation .....</b>	<b>2,206</b>	<b>*3,233</b>	<b>3,661</b>	<b>3,890</b>	<b>3,115</b>	<b>3,512.6</b>	<b>3,543</b>

<sup>a</sup>Electric Power Research Institute, *Overview and Strategy*, July 1979, p. II-32.

<sup>b</sup>Data Resources Inc., *Energy Review*, Winter 1980, Vol. 4, Number 1, p. 146.

<sup>c</sup>The Pace Company, Consultants & Engineers, Inc., *The Pace Energy and Petrochemical Outlook to 2000*, October 1979.

<sup>d</sup>National Electric Reliability Council, *1979 Summary of Projected Peak Load, Generating Capability, and Fossil Fuel Requirements for the Regional Reliability Councils of NERC*, July 1979, pp. 28-31, projections for 1988.

\*This figure represents oil and natural gas generation.

<sup>f</sup>Fossil fuel subtotal includes electricity generation from internal combustion engines which was not specified by fuel type.

<sup>g</sup>Includes 3 billion kilowatt-hours of net Canadian imports.

Note: — indicates not available.



nuclear capacity by 1990, because of schedule delays. EPRI also assumes that natural gas is phased out as a boiler fuel by 1990 and that oil consumption is restricted. The EPRI hydroelectric and new technology generation forecasts are higher because they include gas turbines, multiple-fired units, and diesels.

The Pace study forecasts 4 percent growth in electricity consumption from 1978 through 1990. Nuclear capacity is constrained and therefore is similar to the 1979 *Annual Report* projection. The study assumes that oil and gas are available and are projected to continue generating electricity because of siting and environmental restrictions on coal-fired powerplants. Therefore, electricity generation from oil- and gas-fired powerplants is higher than in the 1979 *Annual Report* and generation from coal-fired powerplants is lower. By definition, new technology generation only includes geothermal generation and excludes generation from other demonstration plants.

The NERC forecast for 1988, rather than 1990, is based on a 4.9 percent growth in demand from 1978 through 1988. It assumes that all new generating units begin operation on the scheduled service dates currently reported by the utilities. This assumption accounts for the higher projection of electricity generation from nuclear powerplants, because the 1979 *Annual Report* incorporates projected schedule delays. Generation from gas-fired powerplants is reduced in response to the PIFUA regulation, which eliminates gas consumption by electric utilities and industry in 1990. As stated earlier, the 1979 *Annual Report* assumes that the exemptions to the regulation will continue to be granted. The NERC estimates of hydroelectric generation are based on adverse river flows and therefore are lower than the 1979 *Annual Report* projection, which assumes average river flows. More electricity is generated from oil because natural gas is not available and less coal capacity exists because the projection is for 1988 instead of 1990.

The nuclear forecasts (Table 4.35) are comparable except for the CONAES study, which forecasts almost 40 percent more nuclear energy. This is because the CONAES study is somewhat less recent than the other projections and, thus, does not reflect the additional problems of the nuclear power industry that resulted from the Three Mile Island incident. In addition, the CONAES forecast assumes an "enhanced supply" strategy for nuclear power that involves significant regulatory reform.

## Coal

Table 4.36 contains coal supply forecasts from five studies, including both this year's and last year's EIA *Annual Report*. The 1979 *Annual Report* forecast of coal production is lower than the 1978 *Annual Report* forecast because of reduced demand by the utility sector. This occurs because the electricity generation forecast is lower overall and because this year it is assumed that growth in coal-fired capacity is limited until 1990 to that already planned. Previously it was considered to be limited only until 1985. The current industrial coal consumption forecast is slightly higher than last year's. Coal exports have also increased because higher oil prices worldwide make the coal more attractive.

The 1979 *Annual Report* projections for electric utility consumption of coal fall between the higher National Coal Association (NCA) forecasts and the lower DRI projections. The NCA forecast assumes electricity generation growth will be 3.9 percent from 1980 to 1990, whereas the 1979 *Annual Report* forecasts 3.2 percent. In addition, the NCA forecasts a higher percentage consumption of lower Btu coal, which means more tons must be produced to obtain the same energy content.

In the industrial/retail sector, the 1979 *Annual Report* projections are approximately double those of NCA and DRI. This may be a result of the differences in the interpretation and implementation of PIFUA, particularly in the time phasing of the conversions. The 1979 *Annual Report* projections reflect a strict interpretation and implementation of the legislation.

In the synthetics sector, the 1979 *Annual Report* forecast falls between the NCA and DRI forecasts. DRI forecasts a large increase in demand for synthetics by 1990, whereas NCA expects a large increase after 1990.

## Natural Gas

Table 4.37 shows several natural gas supply forecasts for the year 1990. The current EIA middle world oil price forecast is compared to both last year's EIA "Series C-High" forecasts and five other forecasts prepared by the American Gas Association (AGA), Data Resources, Inc. (DRI), Pace, Inc., Tenneco, and Exxon.

The supply curves used for this year's forecast are actually a little less optimistic than last year's supply curves. The projected supply, however, is

**Table 4.35 Midterm Nuclear Power Capacity in Commercial Operation: Comparison of Forecasts, 1985–1995 (Gigawatts at Year-end)**

Source	1985	1990	1995
1979 Annual Report.....	86–109	121–139	137–160
1978 Annual Report.....	102–118	142–171	186–225
1977 Annual Report.....	100–122	157–192	—
DOE Utility Survey (January 1980).....	122	169	177
Data Resources, Inc. (December 1979).....	104	136	158
Pace (October 1979) <sup>a</sup> .....	82	133	185
Exxon (December 1979) <sup>b</sup> .....	123	146	177
National Electric Reliability Council (July 1979).....	134	—	—
CONAES (December 1979) <sup>c</sup> .....	—	128–192	—
Nuclear Regulatory Commission <sup>d</sup> .....	98	136	154
Westinghouse Corporation (March 1980).....	103	142	192
Babcock & Wilcox, McDermott Corp. (March 1980).....	105	133	137

<sup>a</sup>The Pace Company Consultants and Engineers, Inc., *The Pace Energy and Petrochemical Outlook to 2000*, October 1979.

<sup>b</sup>Exxon Company, U.S.A., *Energy Outlook 1980-2000*, December 1979.

<sup>c</sup>National Academy of Sciences, Committee on Nuclear and Alternative Energy Systems (CONAES), *Energy In Transition 1985-2010*, December 1979, Tables 11–17 through 11–24.

<sup>d</sup>"NRC Caseload—Planning Projections for Fiscal Years 1982-1986," Nuclear Regulatory Commission, March 1980.

Note: — indicates not available.

**Table 4.36 Coal Consumption by End-Use Sector: Comparison of Alternative Forecasts for 1990 (Million Tons per Year)**

Sector	1978 Actual	1990 Projections				
		1979 Annual Report Middle	1978 Annual Report C-High	National Coal Association <sup>a</sup>	DRI <sup>b</sup>	Pace <sup>c</sup>
Electric Utility.....	481	884	1,158	959	844	840
Industrial.....	73	248	208	125	137	153
Synthetics.....	0	27	41	12	68	34
Domestic Coking.....	71	78	90	75	93	103
Total Domestic Consumption.....	625	1,237	1,498	1,171	1,142	1,142
Net Exports.....	38	108	81	89	90	78
Total Production.....	670	1,343	1,578	1,250	1,260	1,220

<sup>a</sup>National Coal Association, Economics Committee Forecast, 1980.

<sup>b</sup>Data Resources, Inc., *Energy Review*, Winter 1980.

<sup>c</sup>The Pace Company Consultants and Engineers, Inc., *The Pace Energy and Petrochemical Outlook to 2000*, October 1979.

somewhat greater due to substantially higher projected prices for both gas and oil at the wellhead.

The EIA forecasts of conventional production, which include EGR, tight gas sands, and Devonian Shale, are the highest. The EIA forecast for the low-finding rate scenario of a conventional natural gas supply of 16 quadrillion Btu in 1990, however, is more comparable to the other forecasts of the GAO, Tenneco, and Exxon. Although the EIA middle supply forecast of conventional supplies is high, the EIA forecasts for supplies of gas from

supplemental sources are lower than most others. As a result, the forecast of total supply is in the middle of the supply forecast range.

## Oil Supply

EIA's forecasts of the domestic petroleum liquids supply were higher in 1978 than in either 1977 or the current forecast as shown in Table 4.32. In 1978, domestic oil supply was estimated to be 22 to 26 quadrillion Btu per year, whereas the current

**Table 4.37 Projections of Natural Gas Supply: Comparison of 1990 Forecasts**  
(Quadrillion Btu)

Units	1978 Actual	1990 Projections						
		1979 Annual Report Middle	1978 Annual Report C-High	AGA <sup>a</sup>	DRI <sup>b</sup>	Pace <sup>c</sup>	Exxon <sup>d</sup>	Tenneco <sup>e</sup>
<b>Domestic Production</b>								
Conventional .....	19.5	17.8	17.4	15.3-17.3	16.9	16.1	14.9	14.8
North Alaska .....	<sup>f</sup>	0.9	0.9	1.6	0.4	1.0	<sup>f</sup>	1.0
Synthetic Gas .....	0.2	0.3	0.5	1.1	0.6	0.8	0.6-1.0	1.5
Subtotal .....	19.7	19.0	18.8	19.9-21.9	18.0	18.0	15.5-15.9	17.3
<b>Net Imports</b>								
Pipeline .....	0.9	0	0.3	2.1	2.0	1.4	1.8	2.0
Liquefied Natural Gas .....	<sup>g</sup>	0.8	0.6	2.0	1.0	0.8	0.8	3.1
Subtotal .....	0.9	0.8	0.9	4.2	3.1	2.2	2.7	5.1
<b>Total Supply</b> .....	<b>20.6</b>	<b>19.8</b>	<b>19.7</b>	<b>24.1-26.1</b>	<b>21.0</b>	<b>20.2</b>	<b>18.2-18.6</b>	<b>22.4</b>

<sup>a</sup>American Gas Association, *The Future for Gas Energy in the United States*, June 1979.

<sup>b</sup>Data Resources, Inc., *Energy Review*, Winter 1980.

<sup>c</sup>The Pace Company Consultants and Engineers, Inc., *The Pace Energy and Petrochemical Outlook to 2000*, October 1979.

<sup>d</sup>Exxon Company, U.S.A., *Energy Outlook 1980-2010*, December 1979.

<sup>e</sup>Tenneco Oil Company, *Energy 1979-2000*, June 1979.

<sup>f</sup>Included in conventional production.

<sup>g</sup>Less than 0.5 quadrillion Btu.

Note: Non-EIA projections converted from trillion cubic feet with 1,020 Btu per cubic foot.

Numbers may not add to totals because of rounding.

forecast is for 18 to 20. Table 4.38 provides more detailed comparisons of domestic oil supply. The decrease in the forecast is due to a combination of revised oil resource data, changes in the forecasting methodology, revised estimates of drilling rig availability, and higher world oil prices. Without the higher prices, the projected oil production would have been even lower.

The revised oil resource data come from the United States Geological Survey, which, in 1979, revised its estimates of the undiscovered resource base in two out of ten onshore production regions and all four offshore production regions.

In 1977 and 1978, EIA used regional "Hubbert Factors" to estimate additions from indicated and inferred reserves to proven reserves. These factors provide a means of estimating secular additions to proven recoverable reserves from a given level of initially discovered proven reserves. For the 1979 forecast, EIA used revised "Hubbert Factors" only to estimate additions from indicated reserves only. The more uncertain inferred reserves, which consist primarily of new pools and extensions to existing reservoirs, are now estimated along with new fields on the basis of drilling activity within the category of new discoveries. Because this approach reduces the estimates of indicated reserves, it also translates into lower production estimates as Table 4.38 illustrates. Coupled with

the reduced estimates of undiscovered resources from which new discoveries are obtained, the overall impact is to reduce production forecasts.

These changes in the projection methodology and the resource base estimates account for about one-half of the difference between the 1978 *Annual Report* and 1979 *Annual Report* forecasts in relation to the Lower-48 States onshore oil production and for approximately three-quarters of the difference in the offshore production forecast. (See Table 4.38.) The remainder is due to minor data updates and methodology changes, including: restrictions on the growth rate of drilling and the assumption of longer development leadtimes for the offshore areas; a change in the projection methodology of tertiary oil; and, for north Alaska, delays in opening new areas. The overall negative effect is mitigated somewhat by the higher world oil price, which accounts for increases in Lower-48 onshore and offshore.

A principal difference between EIA forecasts and other forecasts is the difference in assumptions. Table 4.38 presents 1990 petroleum liquids forecasts by DRI, Pace, Shell, Exxon and Tenneco. EIA projections of Lower-48 onshore and offshore production from new discoveries are more optimistic than those of Shell and Exxon because those forecasters are pessimistic about remaining resources, accessibility, and finding rates. EIA's

**Table 4.38 Projections of Petroleum and Coal Liquids Production: Comparison of 1990 Forecasts  
(Million Barrels per Day)**

Units	1978 Actual	1990 Projections						
		1979 Annual Report Middle	1978 Annual Report C-High	Shell <sup>a</sup>	DRI <sup>b</sup>	Pace <sup>c</sup>	Exxon <sup>d</sup>	Tenneco <sup>e</sup>
<b>Conventional Crude Oil Production</b>								
Lower-48 States, Onshore								
From Proved Reserves .....	6.20	1.24	1.30	1.31	3.91	—	1.9	—
From Indicated Reserves .....	—	0.88	0.92	0.64	—	—	0.2	—
From New Discoveries .....	—	2.23	3.76	1.12	2.35	—	0.6	—
Subtotal .....	6.20	4.34	5.60	3.07	6.26	4.4	2.7	—
Lower-48 States, Offshore								
From Proved Reserves .....	1.15	0.25	0.20	0.19	—	—	0.4	—
From Indicated Reserves .....	—	0.22	0.30	0.22	—	—	0.2	—
From New Discoveries .....	—	0.66	1.73	0.38	—	—	0.5	—
Subtotal .....	1.15	1.13	2.23	0.79	—	1.0	1.1	—
Total Lower-48 States .....	7.35	5.47	7.83	3.86	6.26	5.4	3.8	8.2
North Alaska								
From Proved Reserves .....	1.09	0.92	0.99	1.37	—	—	1.1	—
From Reserve Additions .....	—	0.58	0.80	1.60	—	—	0.2	—
Subtotal .....	1.09	1.51	1.79	2.97	1.60	1.7	1.3	2.6
Enhanced Oil Recovery .....	0.27	1.34	1.47	0.84	0.47	0.7	0.6	—
<b>Unconventional Crude Oil Production</b>								
Shale Oil and Tar Sands .....	—	0.25	0.20	0.15	0.30	0.2	0.6	0.2
Coal Liquids .....	—	—	—	0.25	0.30	—	0.4	—
Natural Gas Liquids Production .....	1.57	0.99	1.26	1.13	1.51	1.0	0.4	—
Total Petroleum and Coal Liquids Production .....	10.27	9.56	12.54	9.20	10.44	9.0	7.1	11.0

<sup>a</sup>Shell Oil Co., *National Energy Outlook 1980-1990*, February 1980.

<sup>b</sup>Data Resources, Inc., *Energy Review*, Winter 1980.

<sup>c</sup>The Pace Company Consultants and Engineers, Inc., *The Pace Energy and Petrochemical Outlook to 2000*, October 1979.

<sup>d</sup>Exxon Company, U.S.A., *Energy Outlook 1980-2010*, December 1979.

<sup>e</sup>Tenneco Oil Company, *Energy 1979-2000*, June 1979. (Alaskan figure includes South Alaska.)

Note: — indicates not available.

Lower-48 south Alaska onshore and offshore projections are similar to those of DRI and Pace. All projections for north Alaska, including the Beaufort Sea, are similar except for Shell, whose forecasts are almost double those of EIA.

EIA reports gross production of enhanced oil recovery, assuming that the steam needed is produced using natural gas. Other projections appear to report net production, assuming that a fraction of the oil recovered is used to produce the steam. If a net forecast was used, it could reduce the EIA projection by about one-fourth or 20 percent. In addition, the EIA forecast reflects the cost advantages both to certain new EOR projects under the Economic Regulatory Administration's Tertiary Incentive Program and to all incremental EOR supply because of lower tax rates in the Windfall Profits Tax. The treatment of these factors by other forecasters is unknown.

All forecasts of natural gas liquids except Exxon's are similar. Exxon believes that more of the liquids will be shipped and counted with natural gas production. With the exception of the Exxon and Tenneco projections which bracket the other forecasts, the projection range of total liquids production is reasonably narrow.

## CONCLUSION

Although the three base case scenarios differ only in their assumption about the future price of imported oil, the forecasts are actually sensitive to other uncertain factors that will shape the U.S. energy future. A few of these uncertainties have been explored in the various sensitivity analyses reported throughout this chapter and have been summarized in Tables 4.39 and 4.40. The variations

**Table 4.39 1990 Energy Balance Impacts of Major Uncertainties**  
(Quadrillion Btu per Year)

	1979 Annual Report Middle	Low Demand	High Demand	Low Supply	High Supply	Low Oil Prices	High Oil Prices	Load Manage- ment	Shorter Coal Lead Times	Low Auto Effi- ciency	High Diesel Pene- tration
<b>Domestic Supply</b>											
Oil .....	19.6	19.5	19.7	18.9	20.2	18.1	20.3	19.6	19.5	19.6	19.6
Gas .....	18.7	18.2	19.2	18.2	19.3	18.2	18.7	18.5	18.1	18.7	18.7
Coal .....	29.3	28.3	30.4	29.4	29.2	28.5	29.5	29.8	31.1	29.4	29.3
Nuclear .....	8.2	8.1	8.1	8.1	8.1	8.1	8.1	8.2	8.1	8.2	8.2
Other .....	3.7	3.6	3.6	3.7	3.7	3.6	3.6	3.6	3.5	3.7	3.7
<b>Total Domestic Production .....</b>	<b>79.5</b>	<b>77.7</b>	<b>81.0</b>	<b>78.3</b>	<b>80.5</b>	<b>76.5</b>	<b>80.2</b>	<b>79.7</b>	<b>80.3</b>	<b>79.6</b>	<b>79.5</b>
<b>Imports</b>											
Net Oil Imports .....	11.7	10.3	13.3	12.5	11.1	17.0	9.5	11.6	10.8	12.6	11.4
Net Gas Imports .....	0.8	0.8	0.8	0.8	0.8	1.8	0.8	0.8	0.8	0.8	0.8
Net Coal Imports .....	-2.7	-2.7	-2.7	-2.7	-2.7	-2.7	-2.7	-2.7	-2.7	-2.7	-2.7
Net Total Imports .....	9.8	8.4	11.4	10.6	9.2	16.1	7.6	9.7	8.9	10.7	9.5
<b>Total Supply .....</b>	<b>89.3</b>	<b>86.1</b>	<b>92.4</b>	<b>88.9</b>	<b>89.7</b>	<b>92.6</b>	<b>87.8</b>	<b>89.4</b>	<b>89.2</b>	<b>90.3</b>	<b>89.0</b>
<b>End-Use Consumption</b>											
Refined Petroleum Products .....	29.9	28.7	31.2	29.9	30.0	32.7	28.8	29.9	29.9	30.9	29.6
Natural Gases .....	16.9	16.7	17.1	16.5	17.4	17.7	16.7	17.0	17.3	16.9	16.9
Coal .....	7.6	7.2	8.0	7.7	7.5	7.4	7.6	7.6	7.5	7.6	7.6
Electricity .....	10.0	9.6	10.3	10.0	10.0	10.0	10.0	10.0	10.0	10.0	10.0
Subtotal .....	64.4	62.2	66.6	64.1	64.9	67.8	63.1	64.5	64.7	65.4	64.1
<b>Conversion Losses .....</b>	<b>24.9</b>	<b>23.9</b>	<b>25.8</b>	<b>24.8</b>	<b>24.8</b>	<b>24.8</b>	<b>24.7</b>	<b>24.9</b>	<b>24.5</b>	<b>24.9</b>	<b>24.9</b>
<b>Total Consumption .....</b>	<b>89.3</b>	<b>86.1</b>	<b>92.4</b>	<b>88.9</b>	<b>89.7</b>	<b>92.6</b>	<b>87.8</b>	<b>89.4</b>	<b>89.2</b>	<b>90.3</b>	<b>89.0</b>

shown in each reflect the impact of only a single difference in assumption from the medium oil price base case. Greater variation would result from changing more than one assumption at a time. For example, combining the low imported oil price assumption with the low oil supply assumption would lead to higher oil imports than would occur with either assumption change alone.

Of the many energy aggregates addressed in the report, oil imports and delivered natural gas prices are the most sensitive to the underlying assumptions. Oil imports vary almost 100 percent between the low and high oil price import cases in 1990. The sensitivity of natural gas prices results from several factors, including the relative inelasticity of the natural gas supply curves and the provisions of incremental pricing in the Natural Gas Policy Act. For example, the wellhead price of natural gas varies 20 percent between the low and high supply scenario in response to a 5-percent change in production. As previously explained, incremental pricing results in an inverse variation between, (1) the residential and commercial natural gas prices and, (2) the imported oil price. In contrast, the industrial gas price varies with the price of oil.

Several generic sources of uncertainty presently exist and include:

- The price and availability of imports
- The size of the domestic resource base
- The health of the total economy
- The rate at which the capital stock changes in each section
- Changes in policy.

The instability in the Middle East and a changing world demand for oil makes it difficult to estimate both the price and availability of foreign oil. This uncertainty has been addressed by assessing how the U.S. energy market responds under a wide band of oil import prices. The remaining uncertainties are discussed below.

### Macroeconomic Conditions

The low and high demand scenarios represent a growth rate in GNP of 2.2 percent and 3.0 percent, respectively. This difference causes a 7-percent variation in domestic energy use in 1990. Most of this change is a result of increased oil and coal consumption in the transportation and industrial

**Table 4.40 U.S. Energy Prices: Comparison of Alternative Scenarios**

**for 1990  
(1979 Dollars)**

	1979 Annual Report Middle	Low Demand	High Demand	Low Supply	High Supply	Low Oil Prices	High Oil Prices	Load Manage- ment	Shorter Coal Lead Times	Low Auto Effi- ciency	High Diesel Pene- tration
<b>Supply Prices</b>											
Oil (dollars per barrel)											
Domestic (wellhead) .....	35.71	35.12	36.19	35.69	35.35	26.29	43.14	35.71	35.12	36.21	35.59
Imported-Landed U.S. ....	36.54	36.06	37.03	36.55	36.22	27.00	44.07	36.55	36.05	37.03	36.55
Average Refinery Acquisition Cost .....	36.40	35.85	36.86	36.38	36.06	26.89	43.88	36.40	35.85	36.89	36.33
Marginal Price Southwest .....	3.68	3.24	4.00	4.11	3.21	3.43	3.40	3.50	3.21	3.67	3.67
High-Sulfur Bituminous, N. Appalachia .....											
34.92	34.92	34.92	34.92	34.92	34.92	34.92	35.79	34.92	34.92	34.92	34.92
Low-Sulfur Subbituminous, N.W. Great Plains .....											
9.40	9.40	9.40	9.40	9.40	9.40	9.40	9.40	9.40	9.40	9.40	9.40
<b>Demand Prices</b>											
Residential											
Electricity (cents per kilowatt- hour) .....											
5.65	5.56	5.75	5.69	5.60	5.53	5.70	5.56	5.60	5.66	5.66	5.66
Distillate (dollars per gallon) .....											
1.04	1.02	1.07	1.04	1.03	0.83	1.24	1.04	1.02	1.05	1.06	1.06
Natural Gas (dollars per million Btu) .....											
4.65	4.34	4.91	5.01	4.33	4.86	4.40	4.47	4.32	4.63	4.65	4.65
Transportation											
Distillate (dollars per gallon) .....											
1.17	1.15	1.19	1.17	1.15	0.96	1.36	1.16	1.15	1.18	1.19	1.19
Gasoline (dollars per gallon) .....											
1.48	1.46	1.48	1.49	1.47	1.23	1.65	1.48	1.47	1.48	1.46	1.46
Jet Fuel (dollars per gallon) .....											
1.08	1.06	1.11	1.08	1.06	0.87	1.31	1.08	1.06	1.09	1.09	1.09
Industrial											
Electricity (cents per kilowatt-hour) .....											
4.16	4.06	4.26	4.20	4.11	4.05	4.18	4.06	4.11	4.16	4.16	4.16
Residual Fuel Oil (dollars per barrel) .....											
39.13	38.51	40.13	39.17	38.63	29.54	46.68	39.07	38.30	39.60	39.57	39.57
Coal (dollars per ton) .....											
50.86	50.35	51.13	50.96	50.85	50.35	51.40	51.21	51.01	50.98	50.94	50.94
Natural Gas (dollars per million Btu) .....											
4.85	4.50	5.09	5.06	4.47	4.06	4.91	4.74	4.48	4.88	4.85	4.85
Industrial Surcharge (dollars per million Btu) .....											
1.09	1.07	1.04	0.94	1.06	0.27	1.34	1.14	1.07	1.12	1.10	1.10
Raw Materials											
Natural Gas (dollars per million Btu) .....											
3.73	3.39	4.01	4.09	3.37	3.74	3.49	3.56	3.37	3.72	3.73	3.73
All Fuels, All Demand Sectors .....											
8.01	7.82	8.18	8.12	7.84	7.11	8.56	7.92	7.84	8.10	7.95	7.95

sectors, respectively. Activity levels in both of these sectors are quite sensitive to GNP.

### Resource Base

The high and low supply scenarios together illustrate the sensitivity of domestic energy supply to the amount of undiscovered oil and gas resources in the United States. Foremost, the domestic resource availability affects the balance be-

tween imports and domestic production. Natural gas prices also vary significantly, which in turn causes about a 4-percent variation in the end-use price of energy.

### Capital Penetration

The forecast depends on the availability of physical and financial capital in each of the supply and demand sectors. On the supply side, the

forecasts depend on the assumption that both the rail and water transportation systems have the necessary capacity to transport coal shipments in the Northeast, and from the West to the Midwest. For example, coal production in the Northwest Great Plains increases sixfold between 1978 and 1995 and most of this production is consumed outside the region. The rapid increase in coal production in the largely undeveloped West creates an immense demand for social services, such as schools and roads; this in turn places a heavy burden on State and local governments.

Similarly, the availability of oil and gas drilling rigs is uncertain. However, unlike the lack of representation of coal-related infrastructure needs, the building of new oil and gas drilling rigs is constrained in the forecast.

The electric utility construction forecast depends on the assumption that unlimited financial capital is available at a constant cost. As discussed, evidence exist that this assumption, although true in the past, will not be true in the future. Given the low growth forecast for electricity demand, however, the availability of financial capital for utilities is apparently not a constraining factor.

Physical limits on capital expansion by electric utilities, however, are recognized explicitly by assuming that no additional utility plants will be built by 1990 that are not already planned. The effects of relaxing this assumption are shown in the sensitivity case given in Tables 4.39 and 4.40. In this scenario, utilities build additional coal-fired powerplants for use by 1990 when they find it economically attractive and decisions are based upon a life-cycle analysis of capital, operating, and fuel costs. As expected, utilities use more coal and less oil and gas. As a result, residential gas and electricity prices drop. In contrast, coal plants that were originally planned to meet new load between 1980 and 1990 may now be canceled because load growth is smaller than expected. In this case,

utilities would use existing oil and gas plants more intensively.

The industrial sector projections, however, do not reflect any assumptions that constrain the turnover of capital stock. As a result, the forecasts show a dramatic switch to coal by 1985 resulting from high oil and gas prices and PIFUA. In reality, these new plants may not all be built by 1985. In addition, the conflicting nature of environmental and energy regulations can, in some instances, slow the conversion of oil and gas plants to coal. For example, under PIFUA, those plants that have been ordered to convert to coal have 5 years to meet the environmental restrictions, but those plants that voluntarily convert must meet the restrictions immediately. As a result, the rapid transition to coal forecast here for 1985 may not occur that soon.

Similar uncertainties about the rate of penetration of physical capital affect the other end-use sectors. In the transportation sector, the uncertainties center on the penetration of diesel engines and the efficiency of the automobile stock. These uncertainties, as shown in Tables 4.39 and 4.40, affect the level of imports. The residential and commercial sector forecasts depend on the assumption that natural gas consumption in new buildings is constrained by, (1) the availability of natural gas in certain areas and, (2) institutional constraints, such as builder resistance.

### **Policy Uncertainty**

Finally, these forecasts assume that Government policies do not change. In fact, many policies are currently under consideration that could significantly change the U.S. energy outlook. These could include the response to Three Mile Island, the repeal of incremental pricing, utility load management, and mandated utility oil and gas backout.

## 5. Long-Term Energy Supply and Demand: 2000–2020

### SUMMARY OF LONG-TERM PROJECTIONS

The long-term analysis explores the role of new technologies in the energy market for the post-2000 period, and it examines the interaction of new and conventional energy sources as oil and natural gas depletion ensues. This analysis is necessarily broader in outlook, less detailed in scope, and more conceptual in design than the preceding midterm analysis. The midterm projections are based on a detailed cross-sectional analysis of the interactions between regional economics and regulatory programs, and they are obtained considering the complex multifuel, multisector tradeoffs possible in the energy system. The long-term analysis, however, considers how trends in energy demand beyond the turn of the century may be met using available coal, nuclear, and nonconventional resources, and it examines the possible contributions from new technologies.

The sensitivity of new technologies as a group is considered in the long-term analysis. However, the relative role of any one technology is not examined in this chapter and is highly uncertain. The penetration of an individual technology depends on its actual cost (compared with its competitors), which could be much different from the levels assumed in this analysis. Shifts in projected contributions from the various new technologies are likely to occur as better cost information becomes available.

The long-term projections provide a consistent accounting framework to discuss these changes. Although the Nation is becoming measurably more efficient in its consumption of energy per dollar of the gross national product (GNP), energy consumption is projected to increase through 2020. Conventional oil and gas reserves decline throughout the forecast period, and coal, uranium, and renewable resources combine to satisfy U.S. energy demands. The Nation never reaches energy

self-sufficiency over the 40-year time frame considered, but in most of the long-term projections the quantity of imports decreases. As a result, the Nation's vulnerability to arbitrary curtailment of energy imports declines. (These results depend on the major assumption that a synthetic fuels program can be undertaken. However, the rate at which this technology will be developed and utilized remains uncertain.)

The long-term scenario presented in this chapter represents one possible way to meet energy requirements over the next 40 years. The projected levels of production may be difficult to achieve, may impose additional costs not represented in the model, and do not represent the only possible alternative. Several additional scenarios are provided to indicate the sensitivity of these results to changes in selected assumptions.

The long-term forecasts post-2000 are logical extensions of trends observed in the midterm forecast to 1995. Macroeconomic assumptions and world oil price assumptions for each of the three main scenarios, summarized in Table 5.1, drive the projections beyond 2000.

The first and most important assumption in this long-term analysis is that economic growth, measured by real GNP, will maintain a yearly 2-percent growth rate post-2000. This GNP growth rate is consistent with a decreasing population growth rate of 0.5 percent yearly post-2000 (compared to a rate of 0.8 percent yearly from 1978 to 2000), an increasing participation of the overall population in the labor force, and a moderate increase in productivity. In this analysis, average GNP growth rates decline to 2.8 percent yearly post-1980 and 2 percent yearly post-2000.

The second principal assumption is that world oil prices will increase to 2000 and remain constant (in constant dollars) thereafter. Prices are held constant after 2000 to examine more readily the approximate world oil prices at which a "backstop technology" will emerge. The middle and high



**Table 5.1 Key Economic Parameters: History and Projections**

	1955–1980	1980–2000	2000–2020
Average Real GNP Growth* (percent per year).....	3.4	2.8	2.0
Average Fuel Import Bill (percent of GNP).....	0.8	2.7	1.2
World Oil Price* (1979 dollars per barrel).....	Low	Middle	High
Year			
1960.....	—	7	—
1970.....	—	5	—
1975.....	—	16	—
1980.....	27	30	35
1985.....	27	34	40
1990.....	27	37	45
1995.....	27	40	55
2000.....	27	43	60
2010.....	27	43	60
2020.....	27	43	60

\*Assumptions.

price scenarios indicate that with import prices rising to as much as \$43 per barrel, backstop technologies (synthetic fuels) could be developed, and energy self-sufficiency in the United States could almost be achieved. However, if the costs of emerging technologies are higher than the base-case estimates, imports may remain high. With low world oil prices, the long-term energy future for the United States appears to be much like today, having a large demand for imported oil.

Natural gas imports are assumed to be priced at the energy equivalent of imported oil. Quantities of natural gas and oil imports at these prices are used to fill the gap between end-use consumption and domestic production.

Estimates of recoverable resources for conventional natural gas and oil are based on the statistical mean estimates of the U.S. Geological Survey (Circular 725), including recent revisions, estimates of potential, enhanced gas and oil recovery by the Department of Energy (DOE), and estimates of the coal reserve base by the U.S. Bureau of Mines. The Grand Junction office of DOE prepared the uranium reserve and resource estimates; the Nuclear Energy Analysis Division, Energy Information Administration (EIA), prepared the costs of finished uranium fuels.

New technologies costs have come from various studies and DOE organizations. One major assumption, particularly in regard to synthetics and shale oil, is that the rate of construction necessary

to meet the demand for these technologies can and will be achieved. Rates of new technology penetration and cost assumptions are discussed later in this chapter, along with the more detailed assumptions of the long-term forecast.

Table 5.1 shows the average fuel import bill for energy relative to GNP growth rate and world oil price assumptions. The large increase in the fuel import bill between 1955–1980 and 1980–2000 is the result of higher prices of world oil and a relatively large, but constant, level of imports. The decline during the forecast period is due to a decrease in the level of imports and the constant world oil price assumption post-2000.

The general trends in the long-term forecast are shown in Figures 5.1 to 5.3. Figure 5.1 shows the comparison of primary energy supply and end-use consumption. The difference between supply and end-use consumption represents conversion losses by electric utilities and synthetics technologies not counted against end-use energy demand.

Oil, coal, and natural gas provided the major portion of U.S. energy supply in 1978. Conventional oil and gas provide a decreasing proportion of total supply post-2000. Coal, nuclear, and renewable resources provide primary growth in supply.

The trends do not change dramatically in end-use consumption, however. Consumption of liquids and gases remains relatively constant over the 40-year time span. Coal, renewables, and electricity meet major growth in end-use consumption.

Trends in end-use consumption show that liquids and gas consumption in the midprice case declines from 65 percent of total end-use consumption in 2000 to 54 percent in 2020. (See Figure 5.2.) Because conventional oil and gas supplies (including imports) satisfy 92 percent of the total liquids and gas demand in 2000 and 55 percent in 2020 (midprice forecast), the result is a dramatic change in the energy industry, as shown by the forecasted use of synthetic oil and gas technologies.

Energy growth by sector occurs primarily in industry. (See Figure 5.3.) Before 1970, rapid expansion in industry, increases in the size and usage of automobiles, and the size and number of residences and commercial buildings led to growth in all sectors. After 2000, efficiency enhancements in all sectors dramatically slow the growth in energy demand, compared to the years before 1970. Industry, however, emerges as the dominant energy-consuming sector during the forecast period.

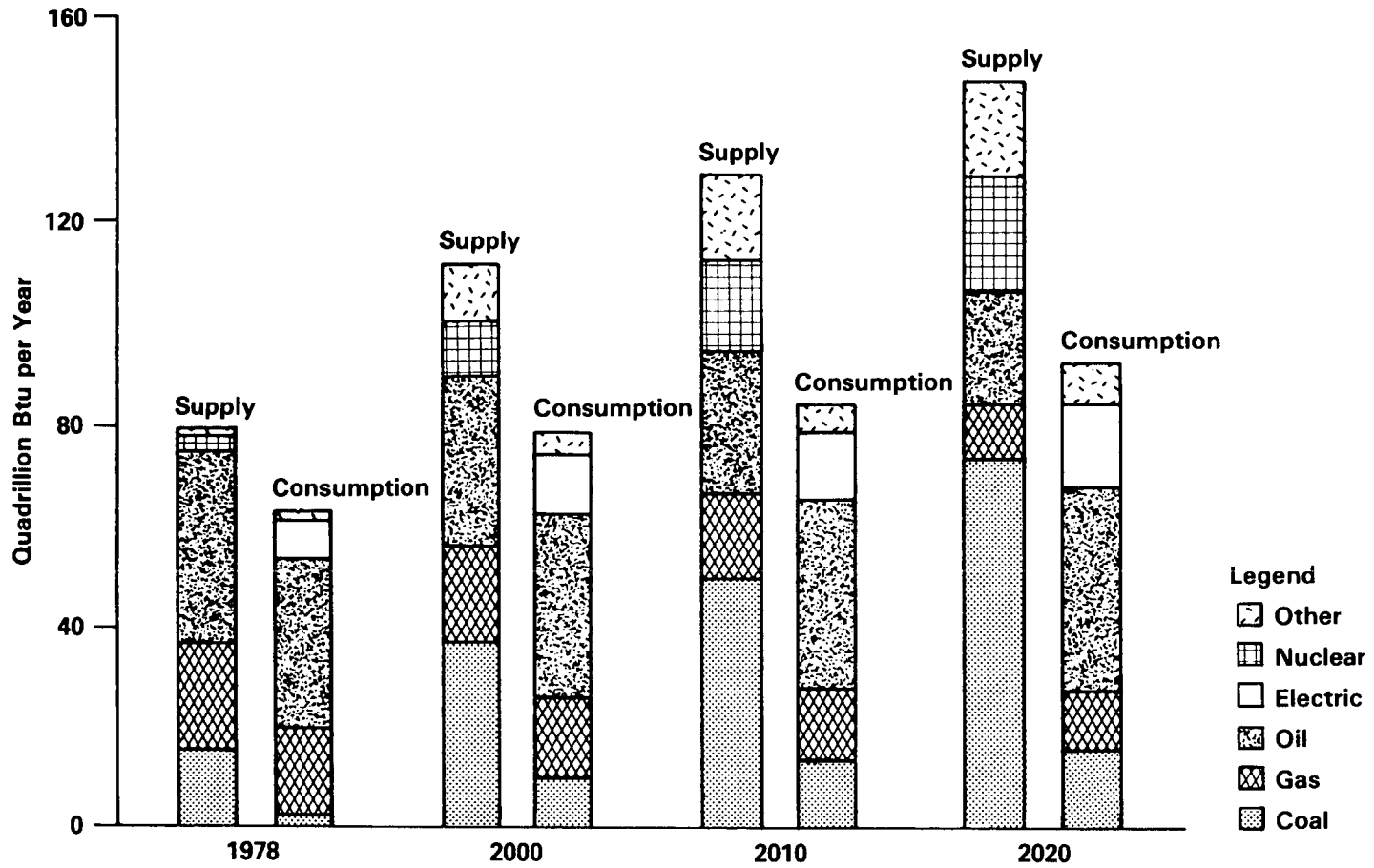

Figure 5.1 Comparison of Total Primary Energy Supply and End-Use Consumption

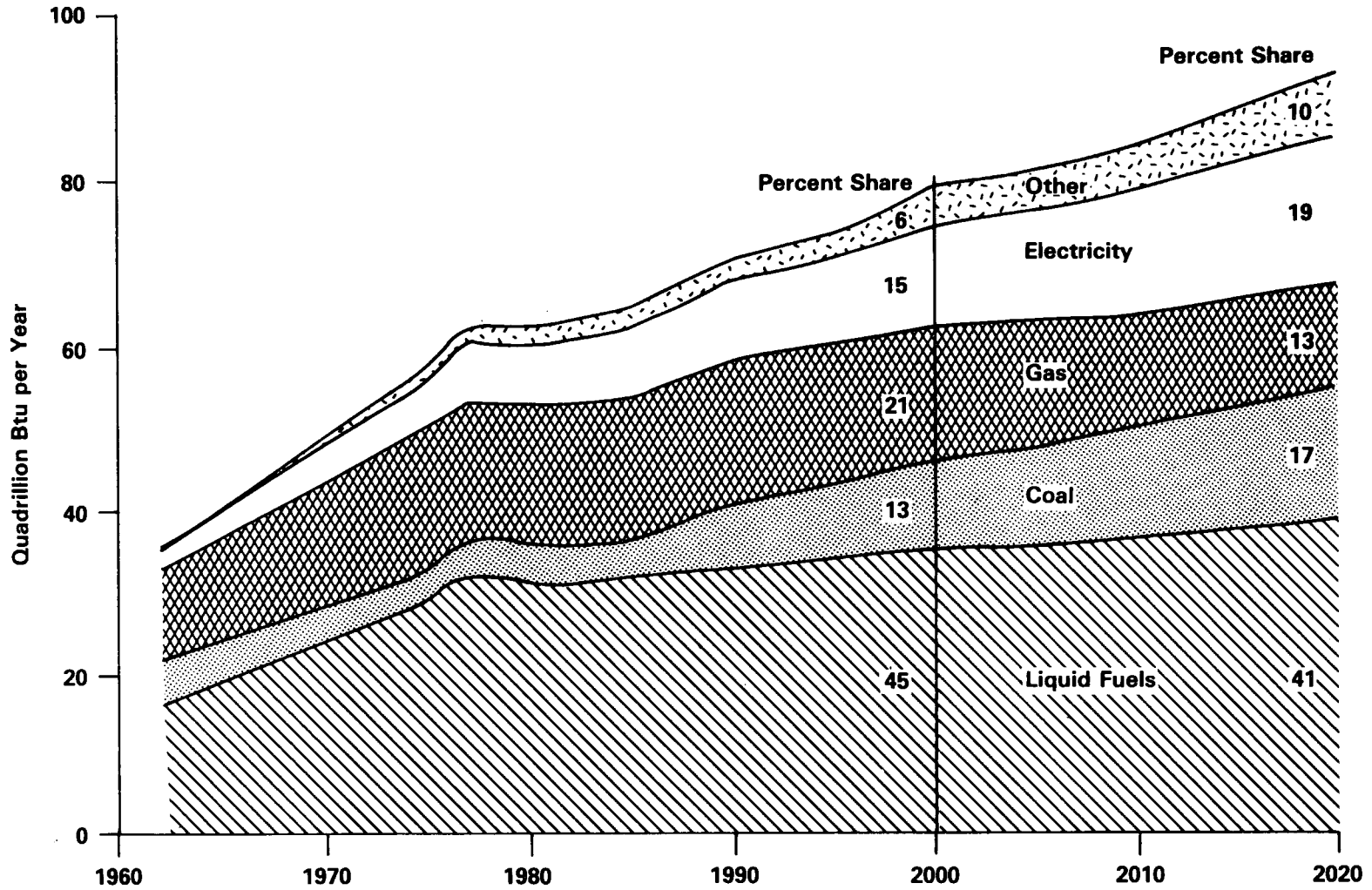

Figure 5.2 U.S. End-Use Energy Consumption by Fuel

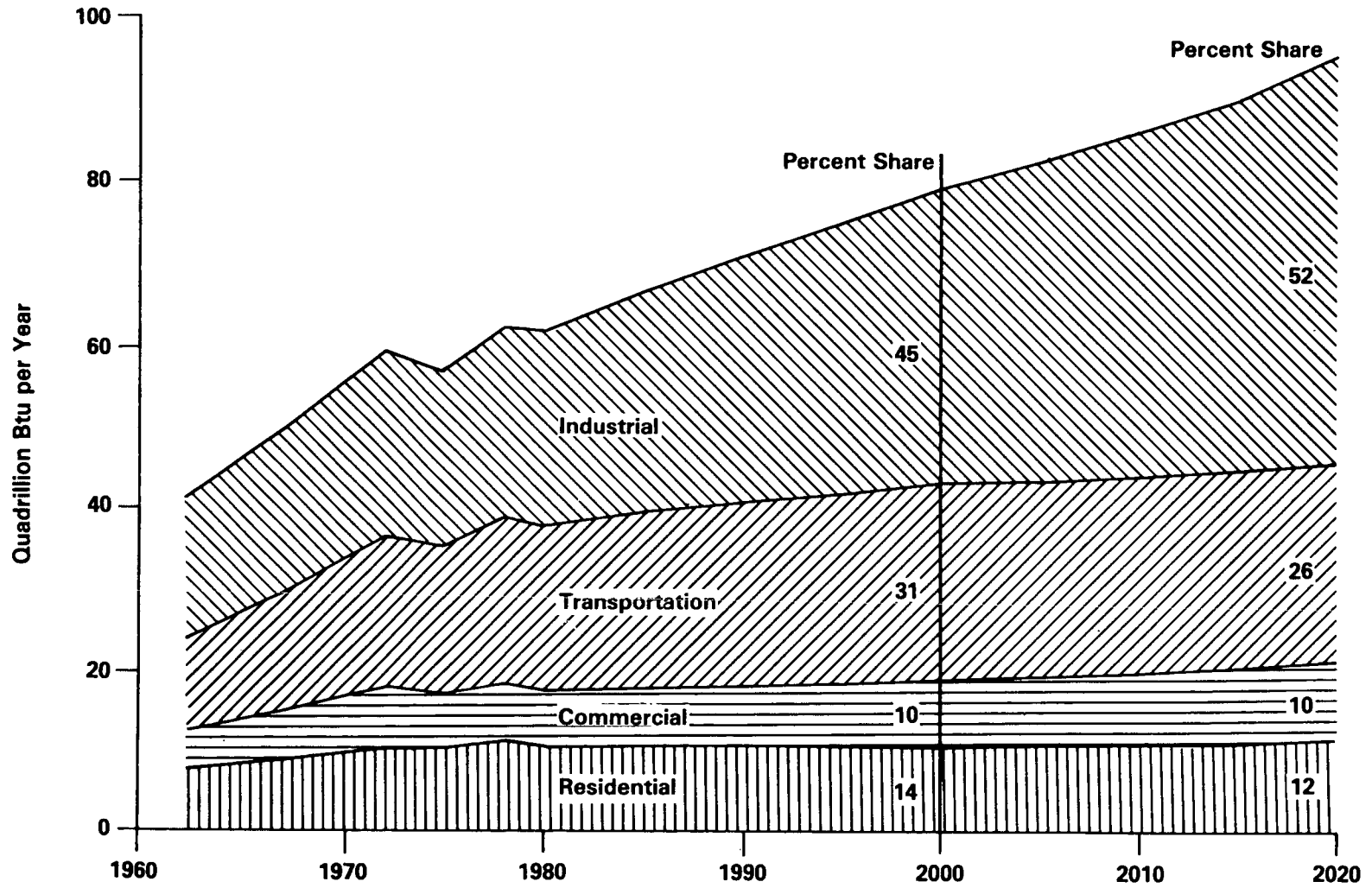

Figure 5.3 U.S. Energy Demand by Consuming Sector

## Comparison with Non-EIA Forecasts

Table 5.2 compares two EIA forecasts with two non-EIA forecasts for 2000 and one for 2010. The EIA forecasts are the result of two alternative assumptions from Table 5.1, coupled to the same macroeconomic assumption. Overall, the EIA scenario for high world oil prices has macroeconomic assumptions and world oil prices comparable to the Exxon and DRI forecasts.

Total primary energy at 105 quadrillion Btu, for the EIA high oil price case, compares with 111 quadrillion Btu for DRI and 102 quadrillion Btu for Exxon. Except for the "other" category, consisting of renewables, the distribution of primary fuel shares is similar for each of these three forecasts for the year 2000. Major differences are the EIA's sizable forecast for renewables (more than double the other forecasts) and negligible

syngas production. (DRI and Exxon forecast only existing renewable technologies: geothermal and hydropower.)

Total end-use consumption is similar for DRI and the EIA high case, with DRI forecasting lower industrial consumption and higher residential/commercial consumption than EIA. Because the Exxon forecast attributes conversion losses to the demand sectors, end-use comparisons with the EIA forecasts cannot be made.

The Committee on Nuclear and Alternative Energy Sources (CONAES) study completed in 1978, yet just recently published, assembles comparable energy balances only for 2010. The CONAES case III is shown for a 2 and 3 percent average GNP growth (labeled low and high GNP, respectively, in Table 5.2) and a \$64.50 world oil price.

Total primary energy ranges from 102 to 140 quadrillion Btu, which envelops the EIA cases at

**Table 5.2 Comparison of EIA, DRI, and Exxon Forecasts for 2000 and EIA and CONAES for 2010**  
(Quadrillion Btu per Year)

	2000				2010			
	EIA		DRI	Exxon	CONAES		EIA	
	Low World Oil Price	High World Oil Price			Case III Low GNP	Case III High GNP	Low World Oil Price	High World Oil Price
<b>Assumptions</b>								
Average Real GNP Growth Base Year 1978 (percent) .....	2.8	2.8	2.6	2.7	2	3	2.6	2.6
World Oil Price (1979 dollars per barrel) .....	27.00	60.00	55.50	NA	64.50	64.50	27.00	60.00
<b>Domestic Supply</b> .....	113	105	111	102	102	140	128	122
Coal <sup>a</sup> .....	34	34	38	33	38	60	43	47
Natural Gas .....	17	17	20	18	16	15	15	15
Syngas .....	( <sup>b</sup> )	( <sup>b</sup> )	(1)	(3)	(0)	(5)	( <sup>b</sup> )	( <sup>b</sup> )
Gas Imports .....	(2)	(1)	(2)	(3)	(2)	(1)	(1)	( <sup>b</sup> )
Crude Oil <sup>c</sup> .....	39	28	35	30	23	32	37	20
Oil Imports .....	(23)	(8)	(15)	(11)	(7)	(14)	(23)	(3)
Syncrude .....	(1)	(1)	(2)	(6)	(8)	(13)	(4)	(7)
Shale Oil .....	1	3	2	3	1	2	2	5
Nuclear .....	11	11	11	13	13	18	18	18
Other .....	11	12	5	5	11	13	14	17
<b>Disposition</b> .....	113	105	111	102	102	140	128	122
Residential/Commercial .....	20	18	25	<sup>d</sup> 35	15	20	21	19
Industrial .....	37	35	29	<sup>d</sup> 46	35	48	43	41
Transportation .....	27	22	22	<sup>d</sup> 20	21	30	26	22
Conversion Losses .....	29	30	35	NA	31	42	37	40
<b>Energy/GNP Ratio (1,000 Btu per dollars GNP)</b> .....	26.8	24.9	27.7	24.7	26.1	25.6	25.0	23.4

<sup>a</sup>Excludes exports.

<sup>b</sup>Less than 0.5 quadrillion Btu.

<sup>c</sup>Includes imports.

<sup>d</sup>Includes losses.

NA = Not Available.

Note: Numbers in parentheses are not included in totals.

Sources: DRI Energy Review (Winter 1980). Exxon Company U.S.A.'s Energy Outlook, 1980-2000 (December 1979). "Energy in Transition 1985-2010," Tables 11-21, 11-22, 11-31, and 11-32, Committee on Nuclear and Alternative Energy Systems, NRC 1979.

128 and 122 quadrillion Btu (low and high, respectively). The higher CONAES primary supply in the 3 percent growth case comes mainly from coal and crude oil imports, as does the additional supply in the EIA scenario for low world oil prices. The demand projections are very similar. Again, the CONAES cases envelop the EIA cases in total end-use consumption.

Finally, the comparison of energy per dollar of GNP shows the EIA forecasts comparable with the non-EIA forecasts for 2000 and the CONAES forecast for 2010.

### Guide to the Chapter

This chapter presents a detailed discussion of the midprice forecast. It begins with an overview and is followed by an analysis of end-use consumption, utility generation, and synthetic technologies. The chapter ends with forecasts of U.S. domestic production. All discussions refer to the midprice case unless otherwise specified. Sensitivity to world oil prices is measured by two alternative forecasts that assume lower and higher prices for world crude oil. (See Table 5.1.) These forecasts are discussed in each section, and a summary is given in the next section.

Additional sensitivity scenarios are also discussed. The two most detailed analyses are a nuclear phaseout case and a case that assumes the costs of building and operating new technologies will be much higher than the "best guess" estimates currently available. The nuclear phaseout case assumes that no new plants will be added post-1995 and that existing plants will be retired after a 30-year operating life. In addition, only nuclear plants currently under construction (and at least 10 percent complete) are allowed to be completed and enter service. The other sensitivity case assumes the cost of new technologies (capital and nonfuel operating) to be twice the base-case costs. The result of these assumptions is a much slower penetration of many technologies, an associated increased deployment of nuclear power, and a relatively high level of imported oil. The results of both these cases are discussed in detail in the Energy Conversion section. Other sensitivity cases are explained in the individual sections.

## OVERVIEW OF THE LOW, MIDDLE, AND HIGH LONG-TERM FORECASTS

### Base-Case Scenario (Middle World Oil Price)

The basic scenario assumptions of the midprice case are given in the previous section and summarized in Table 5.1. These assumptions include a yearly 2.0-percent average growth rate of real gross national product (GNP) after 2000 and a \$43 per barrel (1979 dollars) price for world oil during the forecast period.

Because the long-term forecast period is beyond the point to which 1979 trends can be safely extrapolated, assumptions of post-2000 demands for energy services were based on growth rates contained in the midterm projections. In some cases, demands for energy services were assumed to reach the point of saturation. Examples of such demands are feedstocks, such as synthetic rubber and carbon black in the industrial sector,<sup>1</sup> and refrigerators in the residential sector. In the latter case, the assumption is that each existing residential dwelling in the forecast period will have one or more refrigerators, not that the new housing market will be saturated.

The combined result of these assumptions shows primary energy supply rising from 81 quadrillion Btu in 1978 to 148 quadrillion Btu in 2020. The average annual growth rate from 2000 to 2020 is forecasted at 1.4 percent, down from 1.7 percent forecasted for the preceding 20 years.

Figure 5.1 compares primary energy production with end-use energy consumption for each forecast year. The differences between the two are losses that occur within the energy system. For instance, it takes approximately 3 Btu of coal to produce 1 Btu of electricity. Total conversion losses increase from 21 percent of total primary energy in 1978 to 26 percent in 2000 and to 34 percent in 2020. This results from an increase in demand for both

---

<sup>1</sup> Saturation here is defined as growth reduced to the growth rate in GNP by 2020. Historically, growth in feedstocks has been above this rate.

128 and 122 quadrillion Btu (low and high, respectively). The higher CONAES primary supply in the 3 percent growth case comes mainly from coal and crude oil imports, as does the additional supply in the EIA scenario for low world oil prices. The demand projections are very similar. Again, the CONAES cases envelop the EIA cases in total end-use consumption.

Finally, the comparison of energy per dollar of GNP shows the EIA forecasts comparable with the non-EIA forecasts for 2000 and the CONAES forecast for 2010.

### Guide to the Chapter

This chapter presents a detailed discussion of the midprice forecast. It begins with an overview and is followed by an analysis of end-use consumption, utility generation, and synthetic technologies. The chapter ends with forecasts of U.S. domestic production. All discussions refer to the midprice case unless otherwise specified. Sensitivity to world oil prices is measured by two alternative forecasts that assume lower and higher prices for world crude oil. (See Table 5.1.) These forecasts are discussed in each section, and a summary is given in the next section.

Additional sensitivity scenarios are also discussed. The two most detailed analyses are a nuclear phaseout case and a case that assumes the costs of building and operating new technologies will be much higher than the "best guess" estimates currently available. The nuclear phaseout case assumes that no new plants will be added post-1995 and that existing plants will be retired after a 30-year operating life. In addition, only nuclear plants currently under construction (and at least 10 percent complete) are allowed to be completed and enter service. The other sensitivity case assumes the cost of new technologies (capital and nonfuel operating) to be twice the base-case costs. The result of these assumptions is a much slower penetration of many technologies, an associated increased deployment of nuclear power, and a relatively high level of imported oil. The results of both these cases are discussed in detail in the Energy Conversion section. Other sensitivity cases are explained in the individual sections.

## OVERVIEW OF THE LOW, MIDDLE, AND HIGH LONG-TERM FORECASTS

### Base-Case Scenario (Middle World Oil Price)

The basic scenario assumptions of the midprice case are given in the previous section and summarized in Table 5.1. These assumptions include a yearly 2.0-percent average growth rate of real gross national product (GNP) after 2000 and a \$43 per barrel (1979 dollars) price for world oil during the forecast period.

Because the long-term forecast period is beyond the point to which 1979 trends can be safely extrapolated, assumptions of post-2000 demands for energy services were based on growth rates contained in the midterm projections. In some cases, demands for energy services were assumed to reach the point of saturation. Examples of such demands are feedstocks, such as synthetic rubber and carbon black in the industrial sector,<sup>1</sup> and refrigerators in the residential sector. In the latter case, the assumption is that each existing residential dwelling in the forecast period will have one or more refrigerators, not that the new housing market will be saturated.

The combined result of these assumptions shows primary energy supply rising from 81 quadrillion Btu in 1978 to 148 quadrillion Btu in 2020. The average annual growth rate from 2000 to 2020 is forecasted at 1.4 percent, down from 1.7 percent forecasted for the preceding 20 years.

Figure 5.1 compares primary energy production with end-use energy consumption for each forecast year. The differences between the two are losses that occur within the energy system. For instance, it takes approximately 3 Btu of coal to produce 1 Btu of electricity. Total conversion losses increase from 21 percent of total primary energy in 1978 to 26 percent in 2000 and to 34 percent in 2020. This results from an increase in demand for both

---

<sup>1</sup> Saturation here is defined as growth reduced to the growth rate in GNP by 2020. Historically, growth in feedstocks has been above this rate.

electricity and synthetic fuels having loss factors of approximately 0.67 (excluding line loss) and 0.35, respectively. Conversion losses within end-use sectors, such as energy losses in heaters and vehicles, are not included in the conversion losses here.

The growth in primary energy production is paced by the growth in final consumption, which increases from 63 quadrillion Btu in 1978 to 94 quadrillion Btu by 2020, at an annual growth rate of approximately 1 percent during the forecast period. Figures 5.2 and 5.3 show energy consumed by fuel and by end-use sector. In contrast to the decreasing supply of oil depicted in Figure 5.1, Figure 5.2 shows an increasing demand for liquid fuels in the end-use sectors satisfied by shale oil and synthetic liquids produced from coal and biomass.

End-use consumption of coal from 2000 to 2020 rises from 14 percent of the total consumption to 17 percent of total end-use consumption. Electricity increases from 15 percent to 19 percent over this period, with nuclear energy providing 29 percent of the electricity in 2000 and 38 percent in 2020. Coal dominates all fossil fuels in the utility market, providing 54 percent of the electricity in 2000 and 45 percent in 2020. Coal's decreasing share after 2000 is due to an increased contribution by nuclear and central renewables. Central renew-

ables account for 13 percent of total electricity in 2000 and 15 percent in 2020.

End-use consumption of gaseous fuels, including high-Btu gas from coal, falls from 21 percent to 14 percent of total consumption in this 20-year period. Liquid fuels, including synthetics, follow a similar trend, falling from 45 percent to 41 percent. Quantitatively, consumption of gaseous fuels declines only slightly, and liquid fuels rise, despite conventional resources of oil and gas being largely depleted over the period.

Coal is projected to become the primary source of energy supply beyond 2000, rising from 34 percent of domestic supply to 49 percent by 2020. Nuclear's share grows from 10 to 15 percent, a decrease from the *Annual Report to Congress, 1978*. In this year's forecast, the generation of electricity by coal exceeds that of nuclear throughout the forecast period.

Imports of petroleum and natural gas are forecasted to decrease steadily from 14 quadrillion Btu (6.5 million barrels of oil equivalent per day) in 2000 to 7 quadrillion Btu (3.3 million barrels of oil equivalent per day) in 2020.

Table 5.3 shows growth rates for both domestic supply and end-use disposition for the period 1960 to 2020. These forecasts imply a large growth in the demand for coal, both for direct industrial use and for conversion to electricity or to synthetic

**Table 5.3 Energy Production/Consumption Trends: History and Projections, Middle Case, 1960–2020**  
(Growth Rates per Year, Percent)

	History		Middle Case			
	1960–1973	1973–1978	1978–1990	1990–2000	2000–2010	2010–2020
<b>Domestic Production</b>						
Coal .....	2.0	0.9	5.1	3.4	2.7	3.7
Natural Gas .....	4.4	-2.6	-0.4	-1.3	-1.2	-1.9
Oil .....	2.3	-1.3	-0.5	0.5	0	-3.1
Nuclear .....	41.5	26.8	8.6	3.5	4.8	1.9
Other .....	*4.7	*8.2	4.9	4.4	3.3	2.2
Total Production .....	*3.1	**	2.2	1.9	2.0	1.7
<b>Domestic End-Use Consumption</b>						
Coal .....	-1.8	-4.2	6.1	3.2	2.4	1.7
Electricity <sup>b</sup> .....	7.3	3.2	2.8	2.3	2.1	1.9
Natural Gas <sup>c</sup> .....	4.5	-2.3	0.3	-0.6	-1.2	-1.2
Liquids .....	3.7	1.9	-0.3	0.6	0.2	0.6
Other .....	*	*	7.9	4.2	3.0	3.5
Total Consumption .....	*3.6	*0.7	1.0	1.1	0.8	0.9

\*Not comparable with rates after 1978 because industrial biomass data was not available in earlier years.

<sup>b</sup>Does not include industrial autogeneration, cogeneration, or residential photovoltaic electricity.

<sup>c</sup>Natural gas refers to all high-Btu gaseous fuels and excludes low- and medium-Btu gas.

\*Less than 0.05 quadrillion Btu.



liquids and gases. The 38 quadrillion Btu of coal production forecasted in 2000 is equivalent to 380 western surface mines producing 5 million tons of coal per year; the 72 quadrillion Btu in 2020 is equivalent to 720 mines.

In general, the midprice scenario shows an increased reliance on coal, nuclear, and renewables. It also shows a definite move to technologies that are expected to be available in the middle to late 1990's. These technologies become economically competitive because of higher prices forecasted for fossil fuels other than coal and because of major improvements expected in the efficiencies of these technologies over their present counterparts. Electric heat pumps, available now, and coal-fired boilers using fluidized bed technologies are examples of technologies showing a major penetration.

### Comparison of the Three Scenarios

Forecasts assuming lower and higher world oil prices relative to the midprice case are presented in this chapter. The world oil prices are given in Table 5.1 for each of these cases. The post-2000 world oil prices are \$27, \$43, and \$60 per barrel (1979 dollars) for the low, middle, and high cases, respectively.

Figure 5.4 displays the range of results for primary energy supply, end-use consumption, and net imports for each of the three cases. Table 5.4 summarizes energy supply and end-use disposition by fuel for the forecast period and for each scenario.

The major difference in the three cases is the level of gas and oil imports, which, in 2020, is 17 percent of primary energy supply for the low oil price case and 1 percent for the high oil price case. Coal, which is converted to synthetic liquids, primarily supplements the increasing demand for liquid fuels in the high case. In the low case, 3 percent of total liquids demand in 2000 and 21 percent in 2020 is composed of synthetic coal liquids. In the high case, these percentages are 5 and 48, respectively.

A basic assumption in the high oil price case is that, assuming a maximum growth rate for the industry, synthetic production can meet demand, and the capital and the raw materials required can be supplied. Synthetic liquids from coal and shale oil in the midprice case are calibrated to midterm levels. The assumptions on synthetic growth dur-

ing the forecast period result in a maximum average annual growth rate from 2000 to 2010 of 11.5 percent, decreasing to a lower annual growth rate from 2010 to 2020 of 8 percent.

The price of synthetic liquids is assumed to be the estimated minimum acceptable price. This assumption is made to analyze the impact of new synthetic technologies and to identify when their contribution is significant enough to displace imports as the marginal crude. As a result of this pricing assumption, the synthetic liquids price after 2000 falls below the price of domestic crude, which is equal to the price of imported oil. The average acquisition cost for a refinery is the quantity-weighted average of the synthetic liquids price and the assumed world oil price. This lower synthetic price could result due to Government subsidies or Government regulation of the synthetic fuel industry.

These assumptions cause the national average price of liquids to the end-use sectors to decrease over time as synthetics penetrate the market. The national average price of light and heavy oil to all sectors, except for transportation, is less than the assumed world oil price for crude oil in the high case for 2020. (See Table 5.5.) That is, the almost 50 percent penetration of synthetics to total liquids demand causes the price, including refining and transportation costs, to be less than the assumed world oil price.

U.S. oil imports decline significantly in the midprice case, although they are not entirely displaced by 2020 even in the high world oil price case. Although imports are currently the marginal crude, it is not clear from these results whether imports would still be the marginal crude in 2020. Synthetic crude in the long term could become the marginal source for meeting liquids demand.

The long-term forecast incorporates price differences based on geographical and other factors in its national projections of quantities and prices. These factors include plant location, transportation costs, and quality differences. Synthetic plants using western coal are assumed to be minemouth plants, so no coal transportation costs are involved. However, a shipping charge for water is added. A buyer's geographical location affects the price paid for energy, with buyers nearer the supply source (such as a coastal location for an oil importer) paying less than a buyer located farther away from a supply source. Different quality coal and synthetic liquids also result in price differences affecting the market price of oil.

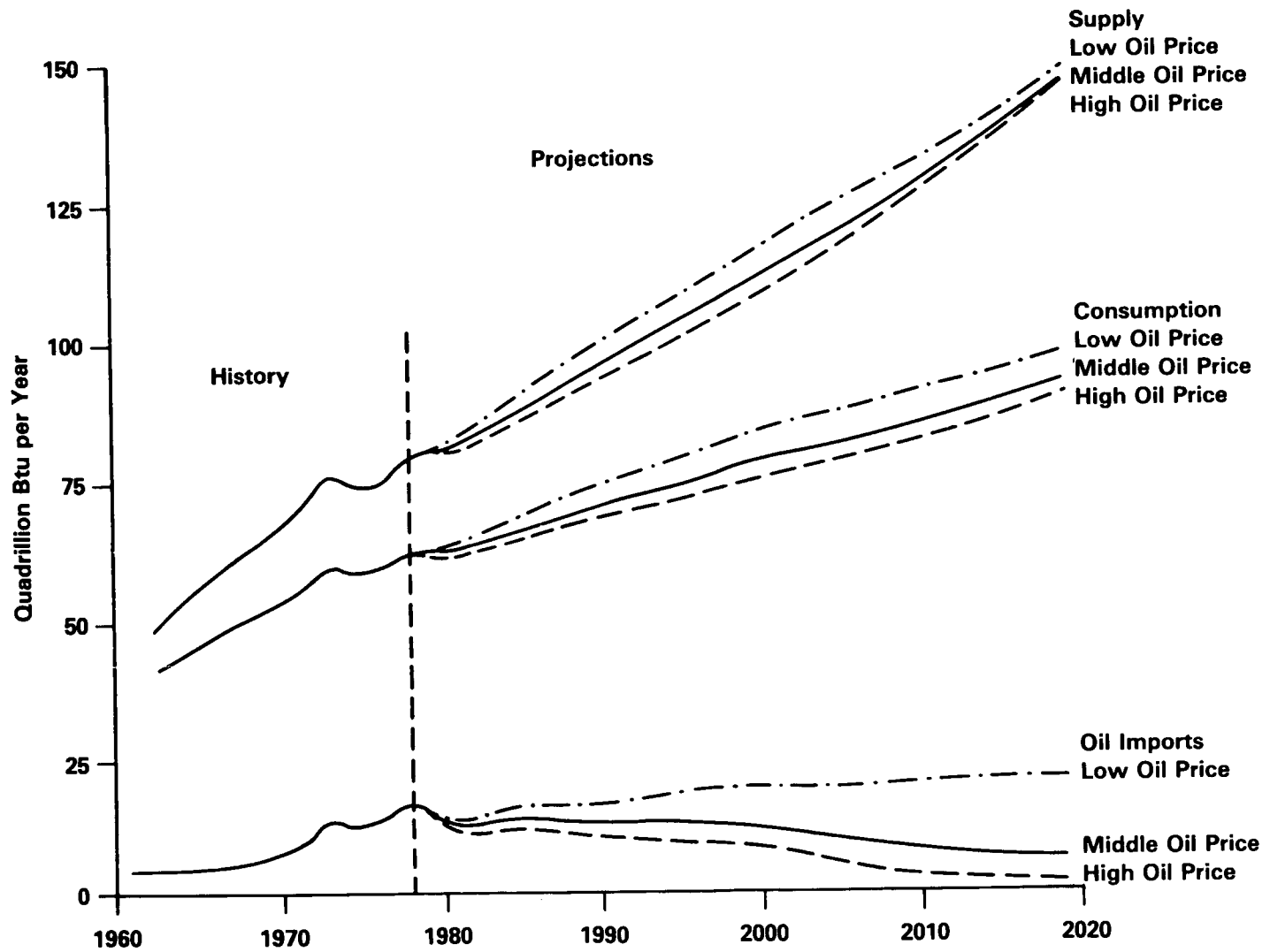

Figure 5.4 U.S. Primary Energy Supply and End-Use Consumption Sensitivity to World Oil Price

**Table 5.4 Energy Supply/Disposition Summary: Projection Series Low, Middle, High**  
(Quadrillion Btu per Year)

	1978	2000			2010			2020		
		Low	Mid	High	Low	Mid	High	Low	Mid	High
<b>Domestic Supply</b>										
Coal .....	15.0	37.3	38.2	37.9	46.4	49.7	50.8	61.4	71.6	74.8
Natural Gas .....	19.5	15.6	16.4	16.2	14.3	14.6	14.8	11.6	12.1	12.4
Oil .....	20.7	17.0	20.5	21.8	16.2	20.6	21.7	11.2	15.0	14.6
Nuclear .....	3.0	11.3	11.3	11.3	17.9	18.1	18.1	21.2	21.8	22.0
Other .....	4.3	10.7	11.7	12.0	13.9	16.2	16.7	18.5	20.1	21.5
<b>Total Domestic Supply .....</b>	<b>62.5</b>	<b>92.0</b>	<b>98.0</b>	<b>99.2</b>	<b>108.8</b>	<b>119.1</b>	<b>122.1</b>	<b>123.8</b>	<b>140.7</b>	<b>145.3</b>
Net Natural Gas Imports .....	0.9	1.7	0.7	0.6	0.8	0.2	0.2	1.1	0.1	*
Net Oil Imports .....	17.1	23.3	13.1	8.4	22.6	8.4	3.4	24.2	6.8	2.0
<b>Total Supply .....</b>	<b>80.5</b>	<b>117.0</b>	<b>111.8</b>	<b>108.2</b>	<b>132.1</b>	<b>127.8</b>	<b>125.6</b>	<b>149.2</b>	<b>147.6</b>	<b>147.3</b>
<b>End-Use Disposition</b>										
Liquids .....	34.2	40.9	35.4	32.3	42.6	36.2	33.5	44.7	38.3	36.4
Natural Gas* .....	16.7	16.4	16.2	15.9	14.6	14.4	14.5	12.8	12.7	12.7
Coal .....	3.6	10.1	10.5	10.2	12.7	13.3	13.2	14.7	15.7	16.4
Electricity .....	6.8	12.1	12.0	11.9	14.8	14.7	14.7	17.9	17.7	17.7
Other .....	1.3	4.8	4.9	5.1	6.6	6.6	6.5	9.2	9.3	8.2
<b>Total End-Use Consumption .....</b>	<b>62.6</b>	<b>84.3</b>	<b>79.0</b>	<b>75.4</b>	<b>91.3</b>	<b>85.3</b>	<b>82.4</b>	<b>99.3</b>	<b>93.7</b>	<b>91.4</b>
<b>Conversion Loss</b>										
Utility <sup>b</sup> .....	16.6	27.8	27.4	27.2	34.0	33.7	33.6	40.2	39.9	39.8
Synthetics .....	0.0	1.2	1.8	1.9	3.0	5.1	5.8	5.8	10.2	12.2
Stock Change <sup>c</sup> .....	0.4	—	—	—	—	—	—	—	—	—
Net Coal and Coke Exports .....	0.9	3.7	3.7	3.7	3.8	3.8	3.8	3.9	3.9	3.9
<b>Total Disposition .....</b>	<b>80.5</b>	<b>117.0</b>	<b>111.8</b>	<b>108.2</b>	<b>132.1</b>	<b>127.8</b>	<b>125.6</b>	<b>149.2</b>	<b>147.6</b>	<b>147.3</b>

\*Natural gas refers to all high-Btu gaseous fuels and excludes low- and medium-Btu gas.

<sup>a</sup>Includes distribution loss.

<sup>b</sup>Includes stock changes, losses, gains, miscellaneous blending compounds, unaccounted for supply, and shipments of anthracite to U.S. Armed Forces in Europe.

<sup>c</sup>Less than 0.05 quadrillion Btu.

Note: Totals may not add due to independent rounding.

In contrast to synthetic fuel technologies, renewable resources penetrate only slightly more in the high case (11 and 15 percent of primary energy supply in 2000 and 2020, respectively) than in the low case (9 and 12 percent, respectively). The reasons are twofold: Some renewable technologies are constrained due to availability and locality; others do not penetrate because their costs are still prohibitive compared to the costs of the alternative technologies. The largest increase in renewables is biomass for alcohol production because it satisfies a portion of the demand for liquids. The demand for biomass for conversion primarily to wood alcohol is higher by a factor of 6 from the low to the high price case in 2020 (0.8 quadrillion Btu for the low and 4.8 for the high). Slight increases occur in other renewables, such as solar and geothermal energy.

The transportation and industrial sectors are the most sensitive to high world oil prices. Consumption in the transportation sector is roughly 5 quadrillion Btu lower in 2000 and 3 quadrillion Btu in 2020, lower in the high price scenario than the low price scenario. Industrial demand is 2 quadrillion Btu lower in 2000 and 3 quadrillion Btu lower in 2020, showing a switch from oil to coal in the high price case. The other sectors show very little fuel switching. Their response is solely a decline in demand for petroleum products. (A more detailed discussion of end-use consumption is given later in this chapter.)

These forecasts show essentially no change in the demand for utility-generated electricity as a result of higher world oil prices. This is essentially due to coal and nuclear technologies dominating the utility industry in the post-2000 period, and

**Table 5.5 Summary of Energy Prices: Projection Series Low, Middle, High (1979 Dollars)**

	1978	2000			2010			2020		
		Low 27.00	Mid 43.00	High 60.00	Low 27.00	Mid 43.00	High 60.00	Low 27.00	Mid 43.00	High 60.00
<b>World Oil Price (dollars per barrel)</b>										
<b>Energy Prices by Sector</b>										
<b>Residential</b>										
Electricity (dollars per million Btu).....	12.69	16.23	16.37	16.42	15.84	15.97	15.97	15.99	16.25	16.28
(cents per kilowatt-hour).....	4.33	5.54	5.59	5.60	5.40	5.45	5.45	5.46	5.54	5.55
Light Oil (dollars per million Btu).....	3.82	5.93	8.61	11.18	6.04	8.49	10.32	6.21	8.29	9.23
Natural Gas (dollars per million Btu).....	2.68	4.46	4.67	4.72	4.92	5.23	5.22	5.46	5.90	5.90
<b>Commercial</b>										
Electricity (dollars per million Btu).....	12.84	16.56	16.71	16.76	16.18	16.31	16.31	16.33	16.59	16.62
(cents per kilowatt-hour).....	4.38	5.65	5.70	5.72	5.52	5.56	5.56	5.57	5.66	5.67
Light Oil (dollars per million Btu).....	3.63	5.56	8.24	10.81	5.67	8.13	9.95	5.84	7.93	8.86
Heavy Fuel Oil (dollars per million Btu).....	2.46	4.42	7.08	9.53	4.56	7.03	8.77	4.75	6.87	7.70
Natural Gas (dollars per million Btu).....	2.31	4.50	4.71	4.76	4.96	5.27	5.26	5.50	5.94	5.94
<b>Industrial</b>										
Electricity (dollars per million Btu).....	8.34	12.67	12.82	12.86	12.29	12.41	12.42	12.43	12.69	12.72
(cents per kilowatt-hour).....	2.85	4.32	4.38	4.39	4.19	4.23	4.24	4.24	4.33	4.34
Light Oil (dollars per million Btu).....	3.60	5.63	8.31	10.88	5.74	8.19	10.02	5.91	7.99	8.93
Heavy Fuel Oil (dollars per million Btu).....	2.49	4.49	7.15	9.59	4.62	7.09	8.84	4.82	6.93	7.76
Coal* (dollars per million Btu).....	1.34	2.40	2.43	2.44	2.53	2.58	2.59	2.79	2.94	2.98
(dollars per ton).....	30.15	54.00	54.68	54.90	56.93	58.05	58.28	62.78	66.15	67.05
Natural Gas (dollars per million Btu).....	1.56	4.75	4.96	5.01	5.21	5.52	5.51	5.74	6.18	6.19
<b>Transportation</b>										
Light Oil (dollars per million Btu).....	5.14	9.57	12.25	14.82	9.68	12.14	13.96	9.85	11.94	12.87
Heavy Fuel Oil (dollars per million Btu).....	2.33	4.42	7.08	9.53	4.56	7.03	8.77	4.75	6.87	7.70

\*Excludes metallurgical coal.

thus, the price of electricity changes only slightly with world oil price changes.

The short-term midprice forecast, given in Chapter 3, for the transportation sector shows the estimated price for gasoline in 1980 to be \$1.33 per gallon, in 1980 dollars. (See Table 3.3.) In 2000, the price per gallon of gasoline is forecasted for the midprice case to be \$1.53 in 1979 dollars and \$5.59 in 2000 dollars, the latter assuming an average annual inflation rate of 6.3 percent from 1980 to 2000.<sup>2</sup> (For the high case in 2000, the price per gallon of gasoline is \$6.76 in 2000 dollars.)

As drastic as these figures may seem, the impact of these prices on an individual budget are not that extreme. Assuming an average annual salary of \$15,000 (1980 dollars), an average of 10,000 vehicle-miles driven per year, and an average fleet efficiency of 15 miles per gallon, gasoline expenditures account for 6 percent of the average annual income in 1980. A \$15,000 salary in 1980

becomes approximately \$50,000 in 2000, under the above inflation rate assumptions. With the above assumptions, but using an average fleet efficiency of 25 miles per gallon, the midprice case shows gasoline expenditures to be 4 percent of average annual income in 2000. Growth in annual income above the inflation rate would further reduce the share of gasoline expenditures. (This example assumes no conservation, that is, no fewer miles driven per vehicle in response to higher gasoline prices.)

This trend in rising energy costs may be less rapid after 2000 if the United States becomes more energy-sufficient and, by that period, is well into synthetic liquids production. The relatively inexpensive price of coal can relieve the pressure of high oil prices on the U.S. economy. However, this assumes an average annual growth in the coal industry of 3.2 percent for the middle case and 3.5 percent for the high case, over a 2.5-percent growth rate in the low case where there is a heavy reliance on imports to satisfy liquids demand.

Comparisons of the low, middle, and high cases will be given throughout this chapter. In summary, high world oil prices do encourage conservation in all sectors and some fuel switching, principally in

<sup>2</sup> The long-term forecast only represents light oil in the transportation sector. The gasoline price should actually be higher by approximately 7 percent. Conversion factors used are 5.248 million Btu per barrel and 42 gallons per barrel.

the industrial sector. The United States can take measures by introducing more efficient technologies, by meeting liquids demand through synthetic liquids production from coal and renewable resources, and by encouraging the use of renewables throughout the energy system. These forecasts show one possible energy future, based on the assumptions discussed. In addition, this analysis identifies several important points for this Nation to consider:

- The ability to meet large growth rates in coal production and the associated environmental problems
- The issue of a sizable penetration of nuclear energy in the utility market and the associated nuclear waste problems
- The availability of capital and the ability to build large numbers of synthetic plants and other fuel conversion facilities
- The technical and engineering advances still necessary to make many of the new energy technologies feasible and economically attractive.

## COMPARISON WITH OTHER EIA FORECASTS

### Comparison with the 1978 Long-Term Forecast

Certain events in 1979 have altered the EIA interpretation of the long-term energy situation. Reactions to the Three Mile Island nuclear incident, assumptions of increased prices of world oil, and projections of lower GNP growth rates are now reflected in this year's forecasts. Figure 5.5 shows the combined effect of these changes. Expected domestic energy production between 2000 and 2020 is down an average of 13 percent for each of the target years, and total end-use consumption estimates are reduced an average of 9 percent over this period. (See Table 5.6.) Corresponding energy price forecasts, shown in Table 5.7, are generally higher in this year's forecast, resulting from higher assumptions of world oil price and less production of nuclear electricity.

Projected growth in total end-use consumption for 2000-2020 is about 1.0 percent annually in the two forecasts, although the actual levels of demand by sector are different. Total projected demand for residential energy in 2000 is lower by 1.0 quadrillion Btu in the 1979 forecast. The fuel

splits in this year's analysis show lower consumption of residential oil (distillate plus liquid petroleum gas) and higher natural gas demand. Projected electricity demand is much lower in the 1979 forecast because of the penetration of more efficient technologies, the contributions from alternative energy sources (solar, photoelectric, and geothermal), and the assumed lower GNP growth rate.

Commercial energy demand for 2000 in the 1979 forecast includes 1.7 quadrillion Btu of asphalt and road oil that appeared as industrial energy use in the 1978 forecast. Subtracting this quantity from the 1979 total shows that this year's commercial energy demand for 2000 has decreased by 1.4 quadrillion Btu. Commercial demand for electricity was projected to be higher in last year's analysis, because alternative technologies make a larger contribution in this year's analysis and because total commercial demand in 2000 was higher last year.

The transportation projections for the 1979 report show a higher projected transport demand in both 2000 and 2020 than the 1978 report because of higher projected levels of transportation demand over the forecast period. (See the Energy Consumption section.) Automobile miles per gallon for the fleet average are projected to increase rapidly in both cases, to approximately 35 miles per gallon by 2020.

The 1978 industrial demand forecast was 44 quadrillion Btu in 2000, which compares to 36 quadrillion Btu in this forecast. The major difference in fuel split is a significant contribution of the "other" category (primarily biomass) this year that replaces a portion of last year's industrial coal demand. Other forecasted trends in the industrial sector through 2020 are fairly similar for both years; actual levels, however, are markedly lower.

Demand for utility-generated electricity is down in this year's forecast, due to the assumed lower growth rate of GNP, the addition of cogeneration technologies, and the increased penetration of autogeneration in the industrial sector. (See the Industrial Energy Consumption section.) This year's forecast resembles last year's in its emphasis on coal and nuclear as primary fuels for electrical input, but it also shows a sizable penetration of renewable resources. The proportion of nuclear in the 1979 forecast, however, is much lower than the 1978 forecast. (See the Energy Conversion section.)

Projections of both domestic production of fossil fuels and imports of oil and gas are lower in the

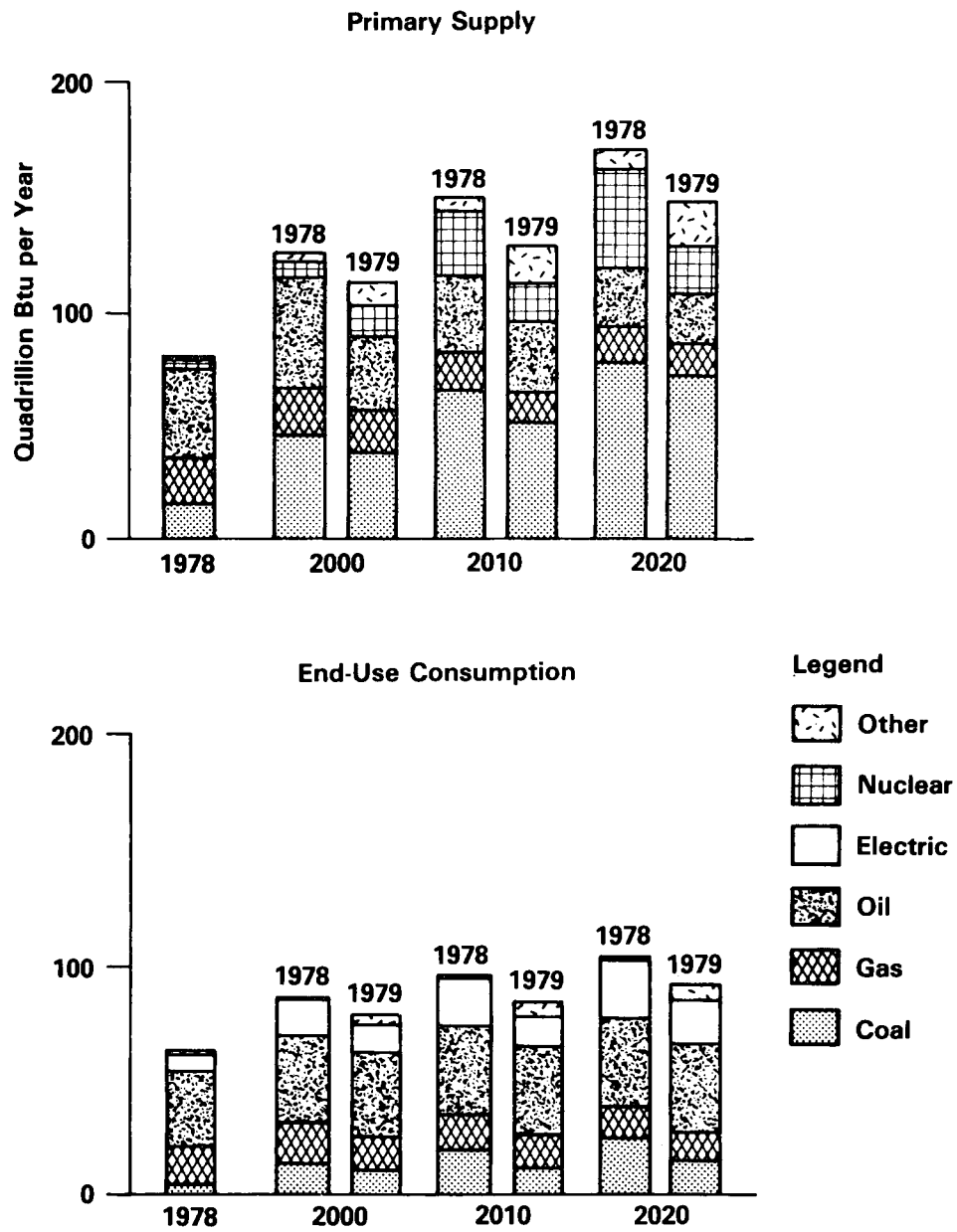

**Figure 5.5 Comparison of 1978 and 1979 Long-Term Projections**

**Table 5.6 Energy Supply and Disposition: Comparison of 1978 and 1979 Annual Report to Congress Projections (Quadrillion Btu per Year)**

	1978 Annual Report to Congress Middle Case			1979 Annual Report to Congress Middle Case		
	2000	2010	2020	2000	2010	2020
<b>Domestic Energy Supply</b>						
Coal .....	46.9	65.2	78.0	38.2	49.7	71.6
Natural Gas .....	19.3	15.3	11.4	16.4	14.6	12.1
Oil .....	24.9	23.2	20.3	20.5	20.6	15.0
Nuclear .....	16.9	29.2	43.6	11.3	18.1	21.8
Other .....	5.0	5.9	7.4	11.7	16.2	20.1
<b>Total Domestic Supply</b> .....	<b>113.0</b>	<b>138.8</b>	<b>160.7</b>	<b>98.0</b>	<b>119.1</b>	<b>140.7</b>
Net Natural Gas Imports .....	1.0	0.8	0.9	0.7	0.2	0.1
Net Oil Imports .....	11.0	8.6	7.4	13.1	8.4	6.8
<b>Total Imports</b> .....	<b>12.0</b>	<b>9.4</b>	<b>8.3</b>	<b>13.8</b>	<b>8.6</b>	<b>6.9</b>
<b>Total Supply</b> .....	<b>125.0</b>	<b>148.2</b>	<b>169.1</b>	<b>111.8</b>	<b>127.8</b>	<b>147.6</b>
<b>End-Use Disposition</b>						
Liquids .....	37.2	38.2	37.7	35.4	36.2	38.3
Natural Gas .....	18.8	16.4	14.4	16.2	14.4	12.7
Coal .....	13.8	20.0	25.4	10.5	13.3	15.7
Electricity .....	15.8	20.5	24.9	12.0	14.7	17.7
Other .....	0.2	0.6	1.2	4.9	6.6	9.3
<b>Total End-Use Consumption</b> .....	<b>85.7</b>	<b>95.7</b>	<b>103.6</b>	<b>79.0</b>	<b>85.3</b>	<b>93.7</b>
<b>Conversion Loss</b>						
Utility* .....	34.8	45.4	56.1	27.4	33.7	39.9
Synthetics .....	1.3	3.8	5.9	1.8	5.1	10.2
Coal Exports .....	3.1	3.3	3.5	3.7	3.8	3.9
<b>Total Disposition</b> .....	<b>124.9</b>	<b>148.2</b>	<b>169.1</b>	<b>111.8</b>	<b>127.8</b>	<b>147.6</b>

\*Includes distribution loss.

Note: Totals may not add due to independent rounding.

1979 forecast. The supply of "other" energy, which includes central renewables (biomass, solar, ocean thermal energy conversion, wind, geothermal, and hydropower) plus end-use renewables (solar space and water heat, solar cooling, biomass, and geothermal) has a much larger share in this year's forecast due to more explicit representations. (See Table 5.6.)

### Comparison with the 1979 Midterm Forecast

#### Comparison of Methodology

The midterm and long-term projections embody different philosophies that lead to intrinsic differences in the results. The midterm analysis emphasizes the detailed consideration of the more im-

mediate conditions of 1985, 1990, and 1995 when conventional technologies dominate, while the long-term analysis emphasizes the general effects of the decreasing availability of conventional fuels and the prospective roles of new technologies.

The following outlines key differences between the two methodologies. (1) The long term has an extended time horizon on financial investments. Financial calculations in the midterm use the conventional financial assumption of constant real prices in the future. In the long-term forecast, each investor is assumed to know the predicted price streams so that decisions on levels of production can be made based on these prices. (2) Midterm resource prices include royalty and similar payments currently made to resource owners. The long-term forecast includes these payments as the rent component of resource price. If the future worth of a resource is known, the owner can

**Table 5.7 Energy Prices: Comparison of 1978 and 1979 Annual Report to Congress Projections**  
(National Averages, 1979 Dollars)

	1978 Annual Report to Congress Middle Case			1979 Annual Report to Congress Middle Case		
	2000	2010	2020	2000	2010	2020
World Oil Price (1979 dollars per barrel)	32.50	32.50	32.50	43.00	43.00	43.00
<b>Energy Prices by Sector</b>						
<b>Residential</b>						
Electricity (cents per kilowatt-hour).....	5.03	5.10	5.20	5.59	5.45	5.54
Light Oil (dollars per gallon).....	1.01	1.11	1.21	1.07	1.05	1.03
Natural Gas*(dollars per million Btu).....	5.54	6.41	7.00	4.67	5.23	5.90
<b>Commercial</b>						
Electricity (cents per kilowatt-hour).....	5.04	5.10	5.23	5.70	5.56	5.67
Light Oil (dollars per gallon).....	.97	1.08	1.15	1.02	1.01	.98
Heavy Oil (dollars per barrel).....	37.55	42.20	46.10	42.50	42.18	41.17
Natural Gas* (dollars per million Btu).....	5.00	5.87	6.46	4.71	5.27	5.94
<b>Industrial</b>						
Electricity (cents per kilowatt-hour).....	3.77	3.83	3.95	4.38	4.23	4.33
Light Oil (dollars per gallon).....	.97	1.08	1.17	1.03	1.02	.99
Heavy Oil (dollars per barrel).....	37.38	42.02	45.94	42.89	42.58	41.56
Coal (dollars per ton) <sup>b</sup> .....	49.18	54.53	60.31	54.78	58.01	65.94
Natural Gas*(dollars per million Btu).....	5.11	5.98	6.56	4.96	5.52	6.18
<b>Transportation</b>						
Light Oil (dollars per gallon).....	1.14	1.24	1.34	1.52	1.51	1.48
Heavy Oil (dollars per barrel).....	36.75	41.39	45.30	42.50	42.18	41.17

\*Natural Gas refers to all high-Btu gaseous fuels, but excludes low-Btu and medium-Btu gas.  
<sup>b</sup>Excludes metallurgical coal.

extract a premium or scarcity rent equal to the maximum present value of delaying production to any future period. (3) Construction estimates for supply technologies largely govern technology penetration in the midterm. The long-term forecast incorporates a specific treatment of the way consumers evaluate alternative products or technologies that compete to satisfy various consumer needs. Because of regional differences in prices and different consumer valuations of energy, the technology with the lowest national average price need not capture the entire market. Each technology can expect a market share that increases as its price becomes relatively more competitive.

### Forecast Comparison

The long-term analysis uses the midterm results in 1995 as the basis for demand projections through 2020. These projections are essentially extensions of the midterm results. End-use consumption sectors represented are the same in both forecasts: residential, commercial, industry, and transportation. The long-term forecast includes

projections of both fuel use and the levels of final services provided (such as space heat or vehicle-miles). The basic fuel uses projected in the midterm are also those considered in the long term, although the correspondence is not exact because of different methods of analyzing and disaggregating fuel use by sector. A pictorial comparison of the two forecasts for 1995 is given in Figure 5.6.

The long-term projection of total 1995 industrial consumption of fuel is 32.7 quadrillion Btu, compared to the midterm projection of 29.7 quadrillion Btu. (See Table 5.8.) The primary reasons for this difference are (1) the long-term analysis includes industrial biomass consumption though midterm does not; (2) industrial electricity generation, which is explicitly represented in the long-term analysis, results in additional conversion losses; (3) more low- and medium-Btu gas in the long-term analysis results in additional conversion losses; (4) medium-Btu gas production projected in the midterm analysis must be adjusted to reflect input fuel used rather than gas output. Total adjusted industrial demand in the long term is about 29.7 quadrillion Btu, which matches the midterm pro-



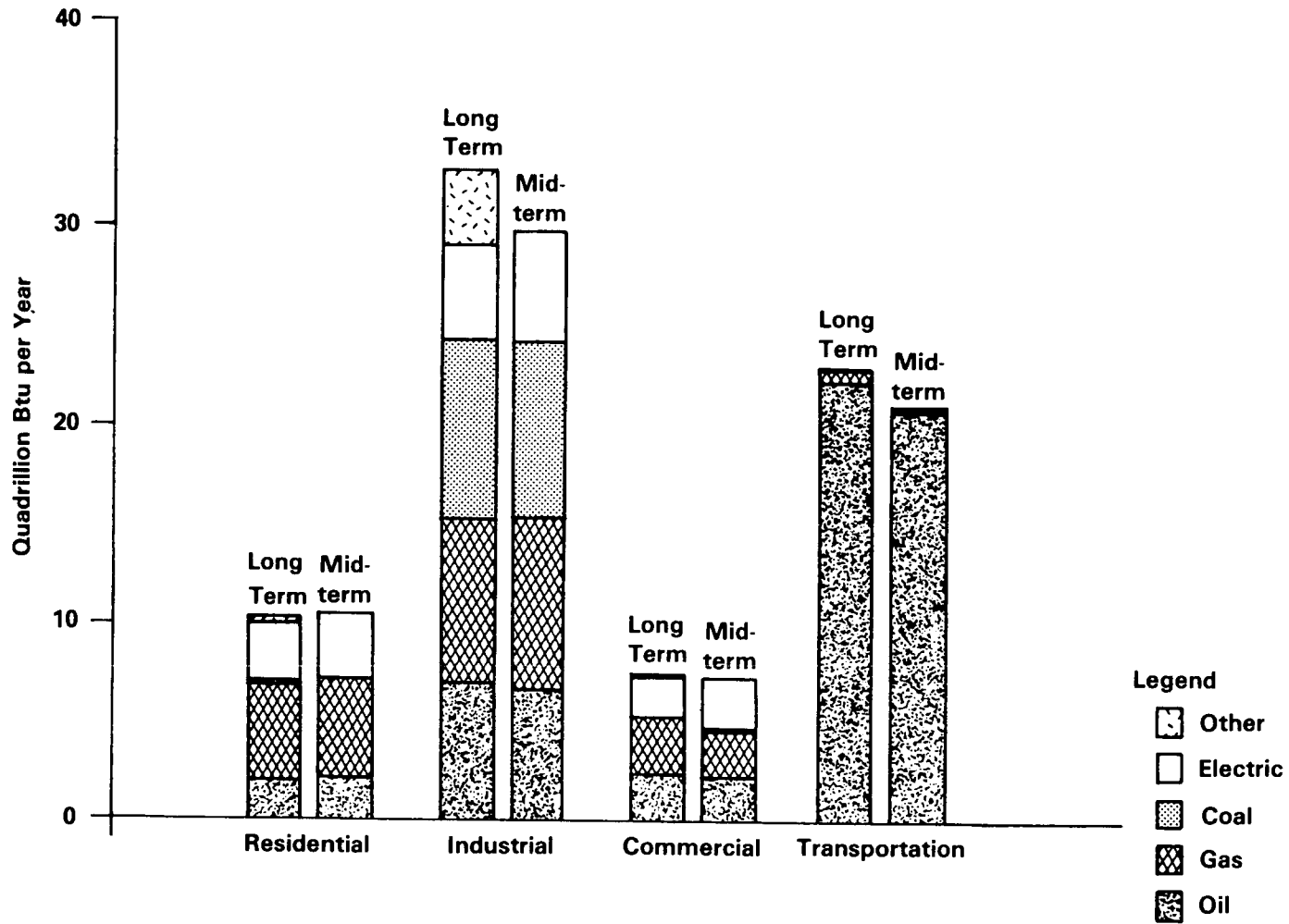

Figure 5.6 End-Use Fuel Consumption: Comparison of Long-Term and Midterm Midprice Scenario by Sector, 1995

**Table 5.8 End-Use Fuel Demand: Comparison of Long-Term and Midterm Midprice Case by Sector, 1995 (Quadrillion Btu per Year)**

Fuel Use by Sector	Long-Term	Mid-term <sup>a</sup>
<b>Residential</b>		
Electricity .....	3.3	3.4
Natural Gas .....	5.0	5.0
Light Oil .....	1.2	1.5
Coal .....	0.2	0.2
Liquid Petroleum Gas .....	0.8	0.8
Other .....	0.3	0
<b>Total .....</b>	<b>10.8</b>	<b>10.8</b>
<b>Commercial</b>		
Electricity .....	2.2	2.7
Natural Gas .....	2.8	2.5
Light Oil .....	0.5	0.4
Heavy Oil .....	0.6	0.4
Asphalt .....	1.5	1.5
Other .....	0.1	0
<b>Total .....</b>	<b>7.8</b>	<b>7.5</b>
<b>Industrial</b>		
Electricity .....	5.0	5.5
Natural Gas .....	8.0	8.6
Light Oil .....	4.4	4.4
Heavy Oil .....	2.1	1.6
Coal .....	8.8	8.7
Lubes, Waxes .....	0.9	0.9
Other .....	3.7	0
<b>Total .....</b>	<b>32.7</b>	<b>29.7</b>
<b>Transportation</b>		
Light Oil .....	20.7	18.8
Heavy Oil .....	1.5	1.1
Electricity .....	0.1	(*)
Pipeline Gas .....	0.6	0.6
<b>Total .....</b>	<b>23.0</b>	<b>20.4</b>
<b>Total Demand .....</b>	<b>74.5</b>	<b>68.4</b>

<sup>a</sup>The midterm industrial demand data are adjusted to include the coal input to midterm medium-Btu gas production of 0.8 quadrillion Btu, instead of the gas output of 0.6 quadrillion Btu.

\*Less than 0.05 quadrillion Btu.

jection for 1995 after these four adjustments are incorporated.<sup>3</sup>

Both the long-term and midterm projections of total fuel demand in the residential sector in 1995 are 10.8 quadrillion Btu. Fuel use splits between the projections are similar, with the exception of 0.3 quadrillion of "other" fuels in the long-term

<sup>3</sup> Details on these adjustments will be available in a supporting analysis report, *Long-term Energy Supply and Demand, 2000-2020*, to be published by the Energy Information Administration, Department of Energy, mid-1980.

forecast. The long-term residential projection explicitly includes several alternative energy sources that are only implicitly considered in the midterm analysis. The most important examples are solar technologies for space and water heating and air-conditioning, and photoelectric cells to produce electricity.

Commercial energy demand in 1995 is projected to be 7.8 quadrillion Btu in the long-term forecast, which is slightly higher than the midterm projection of 7.5 quadrillion Btu. The most important difference between these two commercial projections is the pace at which the commercial sector can be expected to move from oil and gas to electricity. The midterm forecast assumes a faster rate of electrification, with 2.7 quadrillion Btu of electricity demanded in 1995, compared to only 2.2 quadrillion Btu in the long-term forecast. This lower demand of electricity in the long term is counterbalanced by higher projected gas and oil demands.

Total consumption of transportation fuel is higher in the long-term forecast than the midterm projection by 2.6 quadrillion Btu. Most of this difference is in the light oil category, which includes diesel oil, gasoline, and jet fuel. Higher demand for light oil in the long-term forecast is the result of higher assumed growth rates in transportation demand than those used in the midterm forecast. Demand estimates are based on historical information, independent forecasts of service by mode, and assumptions about future personal and freight transportation trends.<sup>4</sup>

The long-term analysis assumes moderate growth in transportation demand through 1995, with equipment efficiency improvements determining fuel-use demand. Consumption of aircraft fuel is higher in the long-term forecast due to a higher expected demand for air passenger-miles. The higher projection of marine ton-miles results in more use of residual fuel for water transport. The long-term analysis also includes an increase in rail demand to support increasing requirements for coal transportation.

<sup>4</sup> Sources include *National Transportation Policies Through the Year 2000*, The National Transportation Policy Study Commission, 1979; *Projections of Direct Energy Consumption By Mode: 1975-2000 Baseline*, Argonne National Laboratory, 1979; *Transportation Energy Conservation Model*, by Jack Faucett Associates, Inc., 1978.

## ENERGY CONSUMPTION

This section presents projections of U.S. energy consumption through 2020 by four end-use sectors: industrial, transportation, residential, and commercial. All demands represent forecasts of national aggregates based on the general assumptions outlined in the previous section and specific sectoral assumptions discussed in the following section.

The presentation of the projections follows a similar outline for each sector. The first section summarizes the activities represented and reviews the major determinants of energy use in that sector. Next is a detailed presentation of the long-term projections, which includes a discussion of trends, changes in end-use technologies, and roles of new fuel sources. A review of renewable energy sources and new technologies is presented after the four sector discussions. The long-term analysis also includes an examination of the sensitivity of energy demand by sector to high and low world oil prices.

The long-term analysis explicitly covers demand by type of fuel in each sector, as well as the levels of end-use services implied by these energy demands. Examples of energy services are: maintaining the temperature inside a house at a given comfort level, steam for industry, and automobile vehicle-miles of travel. Conversion of fuels to final services requires equipment, such as a furnace to convert oil to space heat. This conversion usually results in energy losses, but some very efficient equipment can provide service levels above the energy level of the input fuel (such as heat pumps and solar equipment). End-use service demands thus can be translated into fuel demands, using the conversion efficiencies of the capital stock in each sector. Service demand estimates for 1995–2020 are based on midterm trends and expected growth in demand for that service relative to GNP growth.

Throughout this section, energy consumption refers to the quantity of energy entering the four end-use sectors to satisfy service demands. The figures differ from primary energy consumption by excluding losses incurred in electricity generation, transmission, and synthetic production.

Figure 5.3 shows U.S. energy demand by consuming sector as a share of total end-use consumption. The industrial sector is the largest and most rapidly growing energy consuming sector. (See

Figure 5.7.) Tables 5.9 and 5.10 disaggregate fuel consumption and fuel use by service demand for each sector. Fuel prices by sector are displayed in Table 5.5.

### Industrial Energy Consumption

Total industrial energy use and output are determined primarily by the demand for products of several major industries including manufacturing, mining, and agriculture. This demand, in turn, is driven by the general level of economic activity. The quantity of energy consumption depends both on the types of industrial services demanded and the efficiencies of the equipment supplying these services.

Basic industrial demands include direct and indirect heat, electric services, feedstock, metallurgical coal, lubes, and waxes. Direct heat is used in processes such as cement and brick kilns, glass melting, and steel reheat furnaces. Because the heat of combustion is applied directly to the raw material, the nature of the fuel can affect the quality of the product. In contrast, indirect heat is primarily applied in the form of steam, so the fuel choice is less constrained.

Because direct heat, indirect heat, and electric services are heat and power applications, these processes are only indirectly subject to the market forces of final demand for goods. Other fuels that are embodied in the final product, such as lubricating oils and petrochemical feedstocks, are directly responsive to end-product demands. Metallurgical coal, used for the chemical reduction of iron ore to iron, is responsive to the steel market. Refinery and field uses of gas and oil are driven by the demands for liquid fuels and natural gas.

Prices of energy sources purchased by the industrial sector affect the energy intensity of industrial output and trends in the relative prices of fuels influence the mix of fuels used. Switching from liquids and natural gas is anticipated in the future, in response to higher prices.

The efficiency of service-providing equipment is another important determinant of the level and type of fuel demand. Historical improvements in overall industrial efficiency are projected through the midterm period, as discussed in Chapter 4. This lower growth in industrial fuel consumption compared to the growth in the value of goods produced is also projected for the long term. The challenge

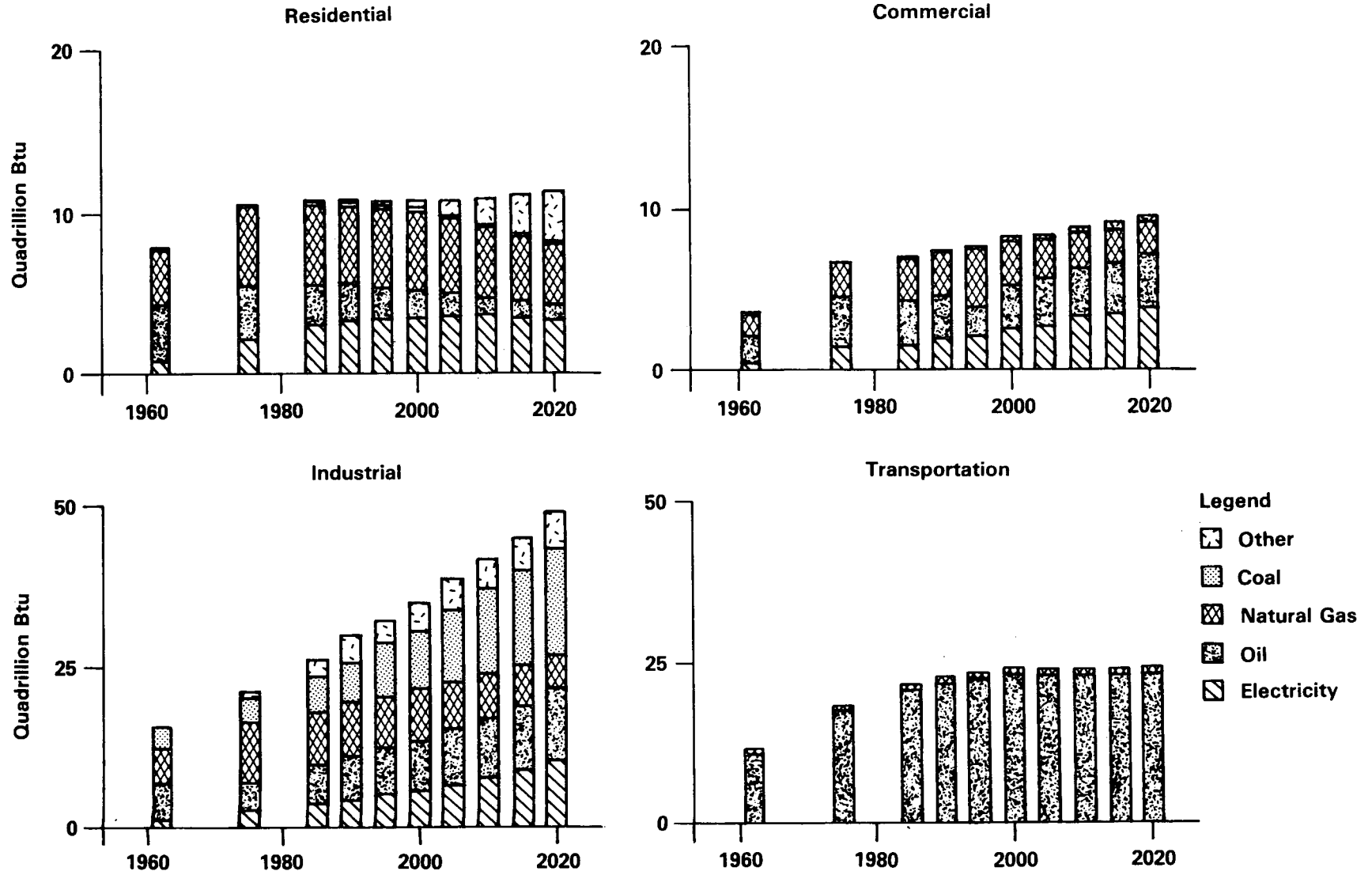

Figure 5.7. End-Use Energy Consumption by Sector and Fuel

**Table 5.9 Fuel Consumption by Sector: Projection Series Low, Middle, High**  
(Quadrillion Btu per Year)

Sector Fuel Use	1978	2000			2010			2020		
		Low	Mid	High	Low	Mid	High	Low	Mid	High
<b>Residential</b> .....	11.1	11.2	10.8	10.5	11.4	11.0	10.8	11.8	11.5	11.4
Electricity .....	2.4	3.5	3.4	3.4	3.6	3.5	3.5	3.4	3.3	3.3
Natural Gas .....	5.2	5.0	4.9	4.9	4.6	4.5	4.5	4.0	3.9	4.0
Light Oil.....	2.2	1.2	1.0	0.9	0.9	0.7	0.7	0.7	0.6	0.5
Coal.....	0.1	0.2	0.2	0.2	0.2	0.2	0.2	0.2	0.2	0.2
Liquefied Petroleum Gas (LPG).....	1.1	0.8	0.7	0.6	0.7	0.5	0.4	0.6	0.4	0.3
Geothermal.....	0	0.1	0.1	0.1	0.3	0.3	0.3	0.6	0.6	0.7
Solar/Other.....	0	0.4	0.4	0.4	0.8	0.9	0.9	1.5	1.5	1.6
Distributed Photovoltaic.....	0	0.1	0.1	0.1	0.4	0.4	0.4	0.9	0.9	0.9
<b>Commercial</b> .....	7.6	9.2	8.2	7.8	10.0	8.8	8.5	10.9	9.6	9.4
Electricity .....	1.7	2.5	2.5	2.5	3.1	3.2	3.2	3.8	3.9	3.9
Natural Gas.....	2.4	2.6	2.8	2.8	2.0	2.3	2.4	1.6	1.8	1.9
Light Oil.....	1.3	0.7	0.4	0.3	0.7	0.3	0.2	0.7	0.3	0.2
Heavy Fuel Oil.....	1.0	1.3	0.6	0.4	1.5	0.5	0.3	1.6	0.5	0.3
Asphalt, Road Oil.....	1.2	1.8	1.7	1.7	2.2	2.1	2.0	2.6	2.5	2.4
Geothermal.....	0	0.1	0.1	0.1	0.2	0.2	0.2	0.3	0.3	0.3
Solar.....	0	0.1	0.1	0.1	0.2	0.2	0.2	0.2	0.3	0.3
<b>Industrial</b> .....	23.3	37.0	35.9	35.1	43.5	41.6	40.9	50.3	48.6	47.6
Coal <sup>a</sup> .....	3.4	10.0	10.3	10.1	12.5	13.1	13.1	14.6	15.6	16.2
Electricity.....										
Utility.....	2.7	5.9	5.8	5.8	7.9	7.7	7.7	10.4	10.2	10.2
Autogeneration <sup>b</sup> .....	0.3	0.5	0.5	0.5	0.5	0.5	0.5	0.5	0.5	0.5
Cogeneration <sup>b</sup> .....	NA	0.4	0.4	0.4	0.5	0.7	0.7	0.7	0.9	1.0
Natural Gas.....	8.5	7.9	7.6	7.4	7.2	6.9	6.9	6.5	6.2	6.2
Light Oil.....	3.6	5.9	5.0	4.7	7.7	6.4	6.1	9.8	8.2	8.0
Heavy Fuel Oil.....	3.2	2.3	2.0	1.8	2.1	1.6	1.5	1.9	1.3	1.3
Geothermal.....	0	0.1	0.1	0.1	0.3	0.3	0.3	0.4	0.4	0.5
Lubes, Waxes.....	0.5	1.1	1.0	1.0	1.3	1.2	1.2	1.5	1.4	1.4
Biomass.....	1.3	4.0	4.0	4.2	4.5	4.5	4.2	5.2	5.2	3.9
Solar.....	0	*	0	0	*	*	*	*	*	*
<b>Transportation</b> .....	20.7	26.8	24.1	22.0	26.5	23.9	22.2	26.2	24.1	23.0
Electricity.....	*	0.2	0.2	0.2	0.3	0.3	0.3	0.3	0.3	0.3
Light Oil.....	19.2	23.7	21.1	19.3	23.0	20.6	19.2	22.5	20.6	19.7
Heavy Fuel Oil.....	1.1	2.1	1.9	1.7	2.5	2.2	2.0	2.8	2.5	2.3
Pipeline Gas <sup>c</sup> .....	0.5	0.8	0.9	0.8	0.8	0.8	0.8	0.7	0.7	0.7
<b>Total End-Use Consumption</b> .....	62.6	84.3	79.0	75.4	91.3	85.3	82.4	99.3	93.7	91.4

<sup>a</sup>Includes metallurgical coal.

<sup>b</sup>These categories are shown for informational purposes but are not included in the total. Fuel used by these processes is already included in the other industrial fuel demands.

<sup>c</sup>Gas transportation losses are included.

NA = Not available.

\*Less than 0.05 quadrillion Btu.

to industry is to continue to improve overall energy efficiency while shifting toward new energy sources. A fundamental assumption underlying the long-term projections is that industry meets these technological challenges.

Table 5.9 shows industrial energy consumption by fuel. Total industrial energy use in the midprice case increases at an average annual rate of 1.5 percent from 2000 to 2020, compared with a GNP growth rate of 2.0 percent. Continued improvement in energy efficiency is achieved despite the projected substitution of low- and medium-Btu gas from coal for natural gas and the increase in industrial electric generation. Both of these

changes shift a portion of the energy losses associated with coal conversion and electric generation to the industrial sector.

Industrial use of light oil, including liquid petroleum gas, is projected to grow at 2.5 percent annually from 2000 to 2020 because of the growth of feedstock requirements. The use of light oil to generate heat declines. Specialized uses, such as fuel for diesel mining equipment and crop drying in dispersed locations, prevent the elimination of light oil as an industrial fuel. The major demand for heavy oil is refinery use of petroleum coke and still gas. These are classified as heavy oil in the long-term analysis because they are byproducts of

**Table 5.10 Fuel Use by Service Demand and Sector, Projection Series Low, Middle, High**  
(Quadrillion Btu per Year)

Sector Fuel Use by Service Demand	1978	2000			2010			2020		
		Low	Mid	High	Low	Mid	High	Low	Mid	High
<b>Residential</b>										
Space Heat .....	6.8	5.8	5.5	5.2	5.5	5.2	5.0	5.4	5.2	5.1
Space Cool .....	0.3	0.6	0.6	0.6	0.7	0.7	0.7	0.7	0.6	0.6
Water Heat .....	1.5	1.8	1.7	1.7	2.0	1.9	1.9	2.2	2.1	2.1
Electric Light .....	0.3	0.4	0.4	0.4	0.5	0.5	0.5	0.5	0.5	0.5
Cooking .....	0.5	0.6	0.5	0.5	0.6	0.6	0.6	0.7	0.7	0.7
Refrigerator .....	0.3	0.3	0.3	0.3	0.3	0.3	0.3	0.4	0.3	0.3
Freezer .....	0.1	0.2	0.2	0.2	0.2	0.2	0.2	0.3	0.3	0.3
Other Gas and Electric .....	1.1	1.5	1.5	1.5	1.7	1.6	1.6	1.8	1.7	1.7
<b>Total Residential Fuel Use.....</b>	<b>11.0</b>	<b>11.2</b>	<b>10.8</b>	<b>10.5</b>	<b>11.4</b>	<b>11.0</b>	<b>10.8</b>	<b>11.8</b>	<b>11.5</b>	<b>11.4</b>
<b>Commercial</b>										
Space and Water Heat .....	4.5	4.5	3.7	3.3	4.4	3.4	3.2	4.4	3.3	3.2
Space Cool .....	0.6	0.8	0.8	0.8	1.0	0.9	0.9	1.1	1.1	1.1
Light .....	0.6	1.0	1.0	0.9	1.2	1.2	1.2	1.4	1.4	1.4
Other Electric .....	0.3	0.6	0.6	0.6	0.8	0.8	0.8	0.9	0.9	0.9
Other Gas .....	0.3	0.4	0.4	0.4	0.5	0.4	0.4	0.5	0.4	0.4
Asphalt, Road Oil .....	1.2	1.8	1.7	1.7	2.2	2.1	2.0	2.6	2.5	2.4
<b>Total Commercial Fuel Use.....</b>	<b>7.6</b>	<b>9.2</b>	<b>8.2</b>	<b>7.8</b>	<b>10.0</b>	<b>8.8</b>	<b>8.5</b>	<b>10.9</b>	<b>9.6</b>	<b>9.4</b>
<b>Industrial</b>										
Direct Heat .....	3.8	4.8	4.4	4.1	4.9	4.6	4.4	5.0	4.7	4.6
Indirect Heat .....	6.5	10.9	10.6	10.4	13.0	12.2	11.9	14.9	14.2	13.5
Electric Services .....	3.6	7.9	8.1	8.1	10.2	10.5	10.5	13.0	13.4	13.5
Feedstock .....	2.4	5.7	5.5	5.3	7.6	7.3	7.1	9.8	9.4	9.3
Met Coal .....	2.0	2.1	2.1	2.1	2.1	2.1	2.1	2.1	2.1	2.1
Lubes, Waxes .....	0.5	1.1	1.0	1.0	1.3	1.2	1.2	1.5	1.4	1.4
Refinery, gas plant, and field use .....	4.6	4.5	4.2	3.9	4.2	3.7	3.5	3.9	3.3	3.1
<b>Total Industrial Fuel Use.....</b>	<b>23.3</b>	<b>37.0</b>	<b>35.9</b>	<b>35.1</b>	<b>43.5</b>	<b>41.6</b>	<b>40.8</b>	<b>50.3</b>	<b>48.5</b>	<b>47.5</b>
<b>Transportation</b>										
Automobile (Oil) .....	10.4	8.9	8.1	7.5	7.7	7.2	6.8	7.0	6.6	6.4
Automobile (Electric) .....	0	0.2	0.2	0.2	0.3	0.3	0.3	0.3	0.3	0.3
Light Truck .....	2.9	3.1	2.8	2.5	2.9	2.6	2.4	2.7	2.5	2.4
Aircraft <sup>a</sup> .....	2.1	5.2	3.8	2.9	5.4	4.0	3.2	5.3	4.1	3.6
Bus .....	0.1	0.2	0.2	0.2	0.2	0.2	0.2	0.3	0.2	0.2
Heavy Truck .....	2.9	5.2	5.1	5.0	5.5	5.4	5.2	5.8	5.6	5.5
Rail .....	0.7	1.0	1.0	1.0	1.2	1.2	1.2	1.4	1.4	1.4
Marine .....	1.1	2.1	2.0	1.9	2.5	2.3	2.2	2.9	2.6	2.5
Pipeline Gas <sup>b</sup> .....	0.5	0.8	0.9	0.8	0.8	0.8	0.8	0.7	0.7	0.7
<b>Total Transportation Fuel Use.....</b>	<b>20.7</b>	<b>26.8</b>	<b>24.1</b>	<b>22.0</b>	<b>26.5</b>	<b>23.9</b>	<b>22.2</b>	<b>26.2</b>	<b>24.1</b>	<b>23.0</b>

<sup>a</sup>Does not include military fuel or international purchases.

<sup>b</sup>Gas transportation losses are included.

Note: Totals may not add due to independent rounding.

the crude oil input. Demand for heavy fuel oil also includes field use of crude oil. Both of these uses depend primarily on the activity level of the petroleum industry. Heavy fuel oil used by the rest of industry includes solid or liquid boiler-fuel made from coal and conventional residual fuel oil. These uses decline over the projection period because fuel oil is not economically competitive with coal. The growth in lubricating oils and other heavy oil industrial products (1.7 percent yearly from 2000 to 2020) falls below the growth rate of GNP, as the

growth rate in vehicle-miles decreases and product improvements reduce the quantities required.

Use of natural gas and synthetic gas from coal, collectively termed high-Btu gas, declines 1.0 percent per year from 2000 to 2020. This decline is largely the result of the use of low- and medium-Btu gases from coal in the direct heat category, where these fuels displace natural gas in meeting the environmental requirements for clean fuel. Gases from coal also are used for indirect heat and cogeneration. An extension of medium-Btu gas

technology could displace the use of natural gas in the production of ammonia for fertilizers, but this use of coal is not represented in the industrial fuel-use data in Table 5.9. The substitution of coal for the usual feedstock raw materials is represented only by the addition of coal-derived liquids to the industrial liquid fuel supply.

After 2000, the fuel mix used to satisfy the industrial service demands continues to shift toward coal in response to the spread between the price of coal and the prices of fuel oils and high-Btu gas. Table 5.5 shows that the difference between the price of heavy oil and the price of coal decreases from \$4.72 in 2000 to \$3.99 in 2020 as liquids from coal, oil shale, and biomass displace higher priced petroleum liquids. The price spread between coal and natural gas increases from 2000 to 2020, and the price of electricity is relatively stable.

Although coal appears to be economically competitive, its share as a percent of total industrial fuel use increases only slightly from 29 to 32 percent over the post-2000 period because the major opportunities for shifting toward coal have largely been exploited by 2000. (See Table 5.9.) Additional penetration of coal is based on new coal-using technologies such as advanced low- and medium-Btu gas production, fluidized-bed combustion, and electricity and steam cogeneration. Coal continues to penetrate the market as these technologies become more cost effective.

Total consumption of utility electricity in industry grows 2.9 percent yearly from 2000 to 2020, while total onsite generation, the sum of autogeneration and cogeneration, grows 2.2 percent annually. Autogeneration is constant over the projection period, while cogeneration grows at 4.1 percent annually.

Autogeneration uses conventional technologies similar to those of the electric utility industry. Because industries that use large amounts of electricity can locate their plants adjacent to utility plants and purchase their power directly, the relative amount of purchased utility electricity and autogeneration is not certain. However, this analysis indicates that onsite generation will be competitive for some major users of electric power.

A cogeneration facility produces both electricity and steam or other forms of useful energy, such as heat, that are used for industrial or commercial purposes. Steam or combustion gases are used

sequentially to produce the electricity and the other forms of energy. In contrast, conventional electricity generation extracts energy from the steam or combustion gases only to drive the generator, and the remaining energy is exhausted into the atmosphere.

Cogeneration results in increased efficiency in energy use, because the incremental fuel required to cogenerate a kilowatt-hour of electricity is typically less than in conventional generation facilities. Because the exhaust gases from one energy use provide the input for another use, total energy services derived from a given fuel input are higher than if both services were provided by separate conversion facilities. Also, the capital cost of adding cogeneration equipment to a new installation is often less than that required for the same generating capacity in conventional facilities.

Studies done in the 1970's have suggested that the potential for industrial cogeneration could be as large as 4 quadrillion Btu of electricity by 1985. A report written for the CONAES study settled on a figure of 2 quadrillion Btu as a provisional forecast for cogeneration in 2010.<sup>5</sup> The long-term analysis projects 0.4 quadrillion Btu in 2000, increasing to 0.9 quadrillion Btu by 2020.

Industrial use of geothermal heat more than triples from 2000 to 2020, based on the assumption that industries that can use geothermal heat will locate near geothermal sources. (See Table 5.9.)

The use of biomass for fuel grows at an annual rate of 1.3 percent from 2000 to 2020. Combustion of biomass is the burning of material, after minimal processing, in a boiler to produce steam. This process helps to satisfy the indirect heat demand in the industrial sector. The principal fuel used is wood or wood byproducts from the lumber and paper industries, as well as some municipal solid waste and agricultural residues in industry.

The projected industrial use of solar power for heat is minimal, largely because most potential industrial users would need a complete backup system. This investment in solar power, however, may be warranted in certain regions, such as the Southwest. Thus the industrial total for solar heat may be underestimated. Photovoltaic electricity generation for industry, which was not evaluated

---

<sup>5</sup> Committee on Nuclear and Alternative Energy Systems, *Alternative Energy Demand Futures to 2010* (Washington, D.C.: National Academy of Sciences, 1979).

for this report, is another new technology the potential contribution of which is uncertain.

The fuels that large plants use to convert coal and biomass to liquid and gaseous fuels for distribution to end users are included in the Energy Conversion section, rather than in Industrial Fuel Consumption in Table 5.9.

Table 5.10 shows fuel use by service demand in the industrial sector through 2020. Total direct and indirect heat grows from 2000 to 2020, at 1.2 percent yearly, which is well below the GNP growth rate. The potential for increased industrial energy efficiency is largest in these areas. Electric services are fueled by utility electricity. This category also includes the fuel used to generate electricity onsite, making the total fuel used to satisfy the demand for electric services greater than the total electricity use shown in Table 5.9.

Feedstocks grow at a annual rate of 2.7 percent from 2000 to 2020, which is substantially below the annual rate of 3.8 percent between 1978 and 2000. This slower increase is due to the relatively high cost of feedstock and the expected saturation of the markets for petrochemicals and other uses. (Saturation is defined as demand growth at or below the level of GNP growth.) One example is the demand for synthetic rubber, carbon black, and rubber processing oil for automobile tires, which is lowered by the production of smaller cars and a reduced growth rate in vehicle-miles. The expanding market for petrochemical insulation is also expected to saturate well before 2020. The market for metallurgical coal, which is used in steel production, remains constant as steel is used more efficiently and as automobile manufacturers use less steel to produce lighter and more energy-efficient cars.

Table 5.5 compares the prices of industrial fuels for the three cases of oil import prices. The largest price impact on liquid fuels occurs in 2000, when light oil prices vary by about \$5.20 per million Btu from the low to high case. These differentials are lower in 2010 and 2020 because of the larger share of synthetic liquids, which are relatively less expensive.

Table 5.10 shows industrial fuel consumption for each world oil price scenario. Differences between scenarios are larger in the later years as industry has more time to adjust to the higher prices. The light oil decreases in response to higher oil prices are roughly equal to the decrease in total industrial fuel use for 2000. (See Table 5.9.) Heavy oil and natural gas use also is lower as oil prices

increase, and electricity use is unchanged. By 2020, the decrease of 0.2 quadrillion Btu in light oil from the middle to the high case is accompanied by a 1.3 quadrillion Btu decrease in biomass. Biomass has shifted from industrial fuel to conversion to liquids used for transportation in response to the increased price of imported crude. Coal use is higher by 1.6 quadrillion Btu from the low to high oil price scenario, offsetting part of the reduction in biomass.

## Transportation Energy Consumption

Energy use in the transportation sector represents fuel consumed in activities associated with moving people and commodities from one location to another. The long-term analysis considers six modes: air, automobile, bus, truck, rail, and marine. Air transport includes passenger-miles for both air carrier and general aviation. (Military use of aircraft fuel was not considered in this year's analysis.) The automobile category covers internal combustion engines and electric vehicles. Bus mileage combines transit, school, and intercity vehicle-miles. Trucks are divided into light truck vehicle-miles for personal use and heavy truck ton-miles for freight movement. Rail transport is reported in ton-miles, although a small amount of the rail fuel use is for passenger service. Marine includes U.S.-purchased fuel consumed for water transport. Pipeline use of natural gas is a calculated percentage of the total gas supply transported from the oil and gas sector.

Demand for fuels is based on demand for transportation services. For example, an assumed demand for automobile vehicle-miles and an associated vehicle efficiency can be translated into a fuel demand. The fuels considered for transportation are light oil, heavy oil, and electricity. Light oil includes jet fuel, gasoline, and diesel fuel. The midterm analysis explicitly considers the split between gasoline and diesel use, while the long-term analysis incorporates the use of these fuels implicitly in efficiency changes. All transportation heavy oil is used by vessels for marine transportation. The small amount of electricity is used to power the electric vehicles that penetrate in the later years.

Potential fuel substitution within a particular transportation mode is limited, given that fuel use by mode is fairly specific. The use of such fuels as



hydrogen, gasohol, and stored electricity may promote fuel substitution, but development of these technologies is expected to occur at modest rates, even in the long term. Also, the amount of fuel consumed by the transportation sector is dominated by energy used in highway travel. Therefore, information on the size of the stock of vehicles and the energy-consuming characteristics of those vehicles is of primary importance.

Table 5.9 shows total energy consumption remaining fairly constant at about 24 quadrillion Btu between 2000 and 2020. However, the services provided by each mode are forecasted to increase. Improvements in transport equipment efficiencies, especially vehicle-miles per gallon and airplane fuel use, allow the same level of input fuel to satisfy increased levels of transportation demand.

Transportation remains the second largest sector of domestic energy consumption throughout the projection period; in all years it exceeds the combined demands for the residential and commercial sectors. Transportation consumes 66 percent of all petroleum liquids in 2000, decreasing to 60 percent in 2020. This share is higher than historical levels, mainly because alternative fuels satisfy other demands in the long term, and little fuel switching is possible in the transportation sector.

Oil, the fuel every mode uses except pipelines, remains a constant 96 percent of total transport fuel over the forecast period. (See Figure 5.7.) Gas used for pipeline transportation declines slightly as economywide fuel demand moves away from gas. Although electric cars are expected to account for nearly 13 percent of intracity vehicle-miles by 2020, electricity consumption is less than 2 percent of total transportation fuel.

Fuel use by service demand in the transportation sector through 2020 is displayed in Table 5.10. Light oil consumed by automobiles falls by 1.0 percent per year between 2000 and 2020. At the same time, vehicle-miles traveled continue to increase at 1.0 percent yearly. Accounting for this service demand level is the expected improvement in the efficiency of internal combustion vehicles. The efficiency for the fleet average increases from 13.8 miles per gallon in 1975 to 25 mpg in 2000 and 37.0 mpg in 2020. Higher penetration of fuel-efficient diesel vehicles allows even greater end-use service per unit of fuel input.

The rapid penetration of light truck use for personal transportation projected over the mid-term will continue, but at a lower rate after 2000,

with vehicle-miles increasing at an average annual rate of 0.8 percent. Efficiency improvements similar to those for automobiles are assumed for light trucks.

After a rapid increase in air passenger-miles before 2000, the rate of increase is projected to continue at 1.0 percent annually through 2020. Aircraft fuel efficiency is also expected to increase over the 2000–2020 period.

All three freight modes are expected to maintain annual growth rates between 1.0 to 2.0 percent from 2000 to 2020. Rail is expected to remain the dominant freight mode in terms of ton-miles to 2020. The reason for rail's continued position is the projected increase in coal traffic. Water transport is also projected to show an increase over this period. Heavy trucking shows absolute growth in ton-miles over time, but the rate is much lower because the commodities experiencing the highest growth are carried primarily by rail and water.

One area of growing emphasis in the transportation sector is the development of electric vehicles. This emphasis is based on the expectation that the net effect of their use would be a reduction in petroleum demand. Electric cars are represented in the long-term analysis as a possible competitor for urban vehicle-miles and are projected to provide 13 percent of those miles by 2020 in the midprice case. The relatively low penetration projected for electric cars reflects the current uncertainty of battery development. Currently, none of the commercially available battery technologies possesses the power or endurance that would enable battery-powered vehicles to match the performance of conventional automobiles. Higher capital costs are assumed for electric cars to reflect these uncertainties. If the capital costs of electric and conventional cars are assumed to be the same, penetration of electric cars increases to 18 percent of urban vehicle-miles by 2020.

A sensitivity analysis of the transportation energy demand to the price of imported oil is shown in Table 5.11. Because fuel consumption in this sector is almost entirely oil, changing prices result in noticeable shifts. The growth rates in service demands for the individual modes are the same for all scenarios, although the actual levels of demand are higher in the lower oil price case because less conservation is encouraged. Prices for light oil in the transportation sector vary widely between cases and lead to different energy conservation responses.

**Table 5.11 Sensitivity of Transportation Service Demand to World Oil Price, 2000–2020**  
(Services Provided per Year)

	1978	2000			2010			2020		
		Low	Mid	High	Low	Mid	High	Low	Mid	High
<b>Travel Mode</b>										
Automobile, Oil (billion vehicle-miles).....	1,194	1,795	1,647	1,520	1,918	1,788	1,693	2,057	1,954	1,899
Automobile, Electric (billion vehicle-miles).....	0	101	95	90	149	144	141	190	187	187
Light Truck (billion vehicle-miles).....	261	462	414	373	492	448	417	523	487	469
Aircraft (million passenger-miles).....	219	751	546	415	826	607	488	870	672	593
Bus (billion vehicle-miles).....	5	9	8	7	10	9	8	11	10	9
Heavy Truck (million ton-miles).....	497	1,085	1,063	1,044	1,199	1,168	1,143	1,314	1,278	1,254
Rail (million ton-miles).....	826	1,583	1,568	1,554	1,874	1,851	1,831	2,222	2,192	2,171
Marine (million ton-miles).....	607	1,445	1,356	1,286	1,696	1,560	1,465	1,939	1,770	1,673

## Residential Energy Consumption

The residential sector consists of single family, multifamily, and mobile homes. End-uses of energy in this sector include space heating, water heating, air-conditioning, cooking, refrigeration, freezing, household appliance operation, and lighting. Energy consumed to provide these services includes both conventional fuels (oil, natural gas, coal, and electricity) and solar energy (both distributed solar and photoelectricity). Other contributions from minor energy sources, such as wood and biomass, are assumed to be negligible in the residential sector over the long term. Energy consumed for personal transportation is included in the transportation sector.

Consumption of energy in the residential sector is determined by the interaction of:

- Energy prices and fuel availability
- Macroeconomic conditions, especially per capita income
- Population and the number and type of households
- The number and characteristics of energy-using equipment
- Energy-use habits
- Government energy policy and conservation programs.

The level of energy prices affects the absolute amount of energy consumed, while relative prices of different energy sources affect the mix among the various sources. Rising prices can result in reduced energy use as consumers adjust thermostats or reduce the amount of hot water used for household functions. Additionally, higher prices encourage consumers to purchase energy saving equipment, such as insulation or solar heating devices. The growth in heat pump installations

following the recent escalation of oil prices is a noteworthy example.

Changes in energy prices also influence future patterns of consumption as more economical fuel sources and more efficient technologies are incorporated in new housing. The types of building and capital stock composition change slowly, but the trends are especially important in the long term as newer houses assume a larger share of the total. The retrofitting of older homes to be more energy efficient as a response to higher fuel prices also influences the total demand for residential energy.

Efficiencies of energy-using equipment are also contributing factors to total energy demand. With efficiency improvements, a given level of service demand, such as that for space heat, can be satisfied with less energy input. It is expected that efficiencies of all major household equipment will improve throughout the forecast period.

Table 5.9 shows that fuel consumption in the residential sector increases at an average growth rate of 0.3 percent between 2000 and 2020. This rate is lower than the assumed growth in residential services and GNP due to more efficient equipment and improved thermal integrities of new homes.

The disaggregation of residential fuel use by fuel type shows the shift from conventional fuels to renewables over the 2000–2020 period, with the conventional electricity share remaining relatively constant. (See Figure 5.7.) Switching occurs both to conventional electric equipment and to more efficient electric technologies, such as heat pumps, as well as to new technologies including solar, geothermal, and distributed photoelectric sources. The light oil and liquified petroleum gas shares decline steadily over the entire projection period. Reasons for this include rapidly rising oil prices in earlier years, the relatively attractive capital costs

of all electric heating and cooling systems, the higher efficiencies of heat pumps using electricity and gas, and the penetration of alternative technologies that become economic as conventional fuels become more expensive. The steady increase in the price of residential natural gas over the projection period is accompanied by a 1.1 percent yearly decrease in natural gas consumption. (See Table 5.5.) Although coal prices remain low throughout the forecast period, distribution and handling constraints limit its use.

Renewable energy sources make significant contributions over the 2000–2020 period. Solar's share grows from 4 percent to 13 percent of total residential demand, while distributed photoelectric is expected to supply 8 percent of residential energy in 2020, up from a negligible quantity in 2000. Geothermal energy also is projected to contribute about 5 percent of total demand by 2020. (See Table 5.9.)

Table 5.10 shows a slight decline in consumption of energy for space heating between 2000 and 2020. The final space heat provided over that period, however, is projected to rise 0.4 percent annually. Increased energy demand resulting from rising income and net additions to the housing stock is balanced by efficiency changes in conventional equipment, adoption of new, more efficient space-heating technologies, and improved thermal integrity of homes. The long-term forecast considers changes in the integrity of homes, which results in more useful heating and cooling output supplied per unit of fuel input. Assumptions of more rapid efficiency changes, such as aggressive retrofitting programs and more stringent building standards, could result in decreasing fuel demands in the residential sector. A sensitivity analysis using the midprice assumptions shows that accelerating the thermal integrity of homes results in a fuel savings of about 2 quadrillion Btu in 2020.

The share of natural gas used in both conventional heaters and heat pumps for residential space heat declines from 41 to 26 percent between 2000 and 2020. Electricity for home heating, used in resistance heaters, heat pumps, and solar backup systems is projected to rise at 0.6 percent yearly from 2000 to 2020. Solar energy is expected to make an increasing contribution to space heating, up from 4 percent in 2000 to 16 percent in 2020. Energy use for central and room air-conditioning is projected to increase only slightly between 2000 and 2020, while space cooling service provided increases at 0.6 percent yearly. Increased air-condi-

tioning efficiency is the result of more efficient equipment and increased thermal integrity of homes. The major shift in residential water heating is away from natural gas, with the solar energy share increasing steadily to 34 percent (0.7 quadrillion Btu) by 2020.

In the high price case, total demand for residential energy is lower, with less oil use and more renewables demand. Total demand for residential energy increases at about the same rate in all cases between 2000 and 2020.

## Commercial Energy Demand

The commercial sector includes economic activity occurring in industries including finance, insurance, retail and wholesale trade, health and education services, office buildings, and other related commercial activities. Also included are all Government purchases of energy for nontransportation-related activities and the construction industry's use of asphalt and road oils for road building and roofing. The long-term representation does not analyze demands for the commercial activities separately, but it determines an aggregate level of demand for energy services in the sector. Energy used for personal and freight transportation is included in the transportation section.

Some of the major determinants of commercial fuel use are energy prices paid by consumers in the commercial sector, the availability of fuels, and economic conditions. Other important factors are net growth in the building stock, market penetration of more energy-efficient equipment in both new and existing buildings, and conservation programs and building standards. Efficiency changes tend to counterbalance the upward trend in demand for services. For a more detailed discussion of the determinants of energy use, see the Residential Energy Consumption section of this chapter.

The long-term representation of the commercial sector does not explicitly consider changes in the thermal integrity of buildings, as considered for homes in the residential sector. Changes in average efficiencies in the sector result from improvements in the efficiencies of energy-using equipment. However, note that the basis for the pre-1995 trends used in the midterm analysis does incorporate assumptions about improvements in building standards. The lower fuel-use demand resulting

from these assumptions is thus implicit in the midterm demand projection from which the post-2000 results are extrapolated.

Table 5.9 shows the 1978 historical energy consumption and the projections of fuel consumption in the commercial sector for 2000–2020. In the midprice case, total energy consumption is projected to increase at an average annual growth rate of 0.8 percent.

A disaggregation of commercial fuel use, by fuel type, shows a switch from oil and natural gas to electricity. (See Figure 5.7.) The midterm trends (Chapter 4) show a similar fuel shifting, although the move from gas occurs more rapidly than is projected by this forecast. This forecast presents an alternative view of the midterm situation. Shares of geothermal and solar energy are anticipated to be 3 percent of commercial energy by 2020.

The basic commercial services provided are space and water heating, air-conditioning, lighting, mechanical drive, and restaurant cooking. Fuel used for space and water heating declines between 2000 and 2020, but final services provided increase. As in the residential sector, efficiency changes more than compensate for the increase in demand. Demand for both space-cooling and lighting services is projected to increase at about 2 percent yearly from 2000 to 2020, keeping pace with the assumed GNP growth.

The fuel prices of energy for the commercial sector are shown in Table 5.5. The move from oil is due to the rapidly rising prices projected over the midterm and the relative inefficiency of oil-burning equipment compared to new electric and renewable technologies. The increase in oil prices is projected to taper off post-2000, owing to the contribution of oil from more economic synthetic technologies. However, switching in the commercial sector continues toward electricity.

With the assumption of high world oil prices, total commercial consumption is lower than the midprice case by 5 percent in 2000 and 2 percent in 2020. Fuel demand is higher than in the midprice case using low world oil prices, up by 12 percent in 2000 and 14 percent in 2020. The response to higher oil prices is mainly a drop in demand for oil (light oil, asphalt, and road oil) and a switch to natural gas and electricity in the mid-1980's.

## End-Use Technologies

This section discusses several new technologies expected to contribute energy to satisfy end-use

demands. A more detailed review of these technologies appears in a supporting analysis, *Long-term Energy Supply and Demand, 2000–2020*, to be published as an Analysis Report by the Energy Information Administration.

### Low- and Medium-Btu Gas Production

Low- and medium-Btu gas production is a conversion technology and is discussed in that section. However, it is treated as an end-use technology because the low energy density of the product gas requires siting at or near the consuming industrial plant. Low- and medium-Btu gas production is expected to be limited to the industrial and utility sectors because of the siting requirement and the poisonous nature of the gas. Its greatest use in this analysis is in cogeneration systems. Low- and medium-Btu gas is also used for direct heat where a clean fuel is required.

### Fluidized-Bed Combustion

Fluidized-bed combustion systems used to produce steam combine fuel desulfurization, combustion, and heat transfer processes in a single reactor and, thus, eliminate the need for a separate desulfurization unit. Because this process requires a smaller combustion chamber than that used in conventional boilers, it is better suited to industrial than utility needs. Fluidized-bed combustion boilers can be either atmospheric or pressurized. The pressurized system represents a more advanced technology with certain advantages, but it is more costly and less developed than atmospheric fluidized beds.

### Solar Industrial Heat

Industrial uses of solar energy include providing steam heat to the petroleum, chemical, and agricultural industries. Solar industrial heating systems may use some of the solar components developed for the residential and commercial sectors, although high-temperature applications require special equipment, such as the concentrating collectors used for thermal generation of electric power. Industrial uses and temperature requirements are varied, often requiring site-specific installations. Industrial loads are usually more predictable and constant than space-heating demands, thus reducing some of the uncertainty involved in efficient sizing of the system.

## Industrial Cogeneration

Cogeneration is the sequential use of steam or combustion gases for generation of electricity and other uses. It results in increased efficiency in the use of energy, because the incremental fuel required to cogenerate a kilowatt-hour of electricity is typically less than in conventional generation facilities. However, this advantage is partly offset by the need for backup power. Industries with cogeneration capability usually pay a demand charge to utilities for the right to purchase electricity during downtime.

The growth of industrial cogeneration may be inhibited for several reasons. Utilities generally have been reluctant to purchase electricity generated by industry at a price attractive to industry, because the generating equipment is not under the control of the utility or in its rate base. Utilities view electricity generated by industry mainly as a fuel saver, and the price offered to industry is likely to be no more than the cost of fuel saved from lower utility generation.

Also, utility regulators might be reluctant to encourage industrial generation, because the possible reduction in the baseload demand for electricity from utilities could tend to increase the price of electricity charged to other customers.

Another consideration is that industry may be reluctant to sell electricity if it is made subject to regulation as a utility as a result of power sales. This obstacle has been reduced by a recent ruling by the Federal Energy Regulatory Commission that industrial sellers of electricity to utilities should not be regulated as utilities.

## Geothermal Heat

Geothermal heat as hot water is currently being used in the residential, commercial, and industrial sectors. The technology is simply to drill, pump the fluid if necessary, and pipe it to the demand location. Temperature limits geothermal energy being used in the industrial sector, because about two-thirds of the indirect heat demand in that sector is for temperatures over 300°F. The amount of the geothermal resources available above that temperature is small. Transportation of the hottest fluid is limited to about 40–50 miles from a well.<sup>6</sup>

<sup>6</sup> L. Fassbender, Battelle Pacific NW Laboratories, Memorandum to Fred Able, U.S. Department of Energy, January 10, 1980.

This limits its use to industries located within range, which is currently about 15 percent of U.S. demand.<sup>7</sup> Location and temperature constraints limit the maximum industrial use of geothermal energy to 5 percent of indirect heat demand. Further increases will depend upon the willingness of industries to relocate to take advantage of the low-temperature, low-cost heat.

Residential and commercial geothermal use usually involves a district heating system, although some large institutional facilities may be able to justify an individual system. Geothermal use in these sectors is constrained by location, but high temperatures are not required.

## Electric Heat Pump

A heat pump in the industrial sector consists of a Rankine cycle system that upgrades an existing low-grade heat source, such as some waste stream. This heat source combined with a small temperature differential between source and demand results in a constant and fairly high coefficient of performance in the industrial sector.<sup>8</sup>

Residential heat pumps typically use ambient air as a heat source, with the efficiency depending upon the temperature differential between inside and outside air. During periods of colder weather, heat pumps must receive supplementary input, commonly from an electric resistance heater. For that reason, heat pump equipment is limited to the more moderate climates of the United States. Despite these limitations, significant penetration of residential heat pumps is expected because they are competing against the high-cost sources of oil and electric resistance heating.

## Distributed Solar Photovoltaics

A discussion of photovoltaic technology appears in the Energy Conversion section. The long-term forecast projects the highest photovoltaic penetration to be in the residential sector. The primary reason is that photovoltaic systems in the residential sector compete with the price of delivered electricity. In contrast, utility options include lower cost electricity generated by conventional

<sup>7</sup> *Ibid.*

<sup>8</sup> D. J. Carpenter, D. A. Thomas, "Low-Grade Refinery Heat Recovery Merits Attention," *Oil and Gas Journal* (January 1980) pp. 137–148.

sources. Also, utilities will not obtain the usual economies of scale for large systems with photovoltaics because cost is primarily a function of hardware requirements rather than plant size.

### **Solar Space Heating**

A solar-heating system collects incident solar radiation and converts it to thermal energy in a working fluid (liquid or gas) to be distributed to the desired demand or stored for later use. This process applies to both active and passive systems. With active systems, a secondary fluid is involved, and some auxiliary power is generally applied. Passive systems employ improved structural designs that allow natural heat transfer phenomena, such as air currents, radiation, conduction, and evaporation to bring about the desired temperature distribution. Many of these design improvements involve little or no cost.

Because of the intermittent availability of solar energy, it is desirable to maintain some level of storage to help match supply and demand. Storage mediums are and will probably continue to be water and rock beds, although some research is being done on advanced systems such as phase-change systems.

Backup systems will be required to serve that portion of the load not supplied by solar heat. Values for the proper proportions of the space-heating load to be supplied by solar energy are site- and system-specific, with the recommended solar contribution ranging from 30 to 100 percent. The principal factors affecting these values are climate, alternative fuel cost, and unit storage cost. The backup could be an independent furnace with a separate distribution system or a burner or coil that is integrated with and controlled by the solar system. Currently, retrofits are much less cost-effective than new installations, thus constraining growth of solar use to the rate of housing stock turnover.

### **Solar Space Cooling**

Solar-cooling systems use collected solar heat to operate a heat transfer device such as an absorption cooler or a Rankine engine. These types of active cooling systems are generally used in tandem with a heating system, thus increasing the load factor on the collectors. Cooling systems, however, require higher temperatures than normally used for space heating.

The most common type of cooling component is the absorption system, which uses the phase change of a refrigerant to extract heat from the occupied space. A Rankine cycle arrangement simply has a steam-driven turbine that powers an air-conditioner, heat pump, or absorption cooler. Most other components of a cooling system would correspond to those for a heating system.

### **Solar Hot Water Heating**

The simplest of solar applications is water heating for residential or commercial use. Temperature requirements are low and the need for a continuous supply is less critical than with space heating, cooling, or electricity. Solar equipment is frequently used to preheat water and is easy to retrofit to a standard water heating system. The basic system components, similar to those for space heating, often are used in combination. Yet, because solar energy is more attractive for water heating than for other demands, this use is more likely than others to be applied alone in a residential or commercial application.

## **ENERGY CONVERSION**

Over the long term, many new and specialized technologies will be used to convert primary fuels to usable secondary fuels. The conversion technologies that are most important in the long term can be divided into two classes: electricity generation and synthetic gas and liquids production. This section discusses the long-term projections for various existing and new technologies under these general classes and gives a brief description of the more significant new technologies.

Technological alternatives are not considered for most other conversion technologies in this analysis. Petroleum refining, which is analyzed in detail for the midterm projections, is considered as a single general process in the long term. The upgrading of shale oil to crude oil quality is also treated as a single processing stage. Two technologies for enrichment of uranium are represented in this analysis and are discussed in the Energy Supply section.

Other topics discussed in this section include: (1) midprice case projections and sensitivities of electricity demand to world oil prices and to high cost assumptions on new technologies, (2) forecasts resulting from a nuclear phaseout scenario that

assumes no additions to nuclear capacity after 1995, and (3) changes in market penetration of new synthetic technologies under high cost assumptions.

## Electricity Generation

Electricity is currently produced by coal-, oil-, and gas-fired generating plants, with major contributions from light-water nuclear reactors (LWR) and hydropower. Several new technologies could make a significant contribution in the long term. The emerging technologies included in this analysis are: the atmospheric fluidized-bed (AFB) boiler, fired by coal; low-Btu gas combined cycle; magnetohydrodynamics (MHD), fired by coal; fuel cell, supplied by coal gasifier; fuel cell, supplied by oil; fast breeder reactor (FBR); fusion; and several renewable technologies. In the latter category are ocean thermal energy conversion (OTEC), solar, biomass, and wind.

The primary reason for considering a variety of technologies is to explore the economic feasibility of new technologies in the long term. Another reason is that different engineering techniques are used to satisfy the continuing baseload and the fluctuating daily and seasonal demands for electricity. Some of the emerging technologies are suitable for baseload operation and others for peakload.

Prospects for electricity generation in the long term depend on broad economic, social, and environmental factors and on the continued availability of primary energy resources such as wind, water power, and fossil fuels. The need to reduce utility consumption of expensive oil and gas supplies and to recognize the limits of new hydroelectric generating sites requires long-term planning for electrification to focus primarily on the use of coal and nuclear fuels, at least until more exotic alternatives become available on a large enough scale. Greater use of these fuels will depend on their respective costs and benefits, adaptability to siting restrictions, and commercial prospects for developing cleaner and more efficient conversion technologies.

Regional limitations on the mining and transportation of large quantities of coal and air quality standards affecting the use of coal might result in higher coal costs and lower growth rates in the use of coal than those projected. Fuel-specific aspects of the outlook for nuclear power involve questions

on the extent of the domestic uranium resource base and the efficiency of current and potential nuclear technologies. In addition, the safety, environmental, and nonproliferation issues associated with nuclear technologies are of increasing domestic and international concern. Finally, the social acceptability of nuclear power, particularly in light of events at Three Mile Island, remains difficult to assess in objective and quantifiable terms. In view of these uncertainties, renewable energy resources could become even more significant than these projections show in satisfying the long-term demand for electricity generated by central utility plants.

## Factors in Long-Term Nuclear Development

This year's forecast shows an increasing demand for electricity, but at rates significantly below those of past projections. This analysis projects gradual changes in the structure of the national generating system. However, during the midterm and the long term, the potential exists for more profound changes. If, for example, rigorous conservation and greater real price increases for electricity, relative to other energy forms, characterize the long-term economic future, requirements for centrally located powerplants could be significantly reduced. In this case, there could be an increase in the use of smaller, dispersed cogenerating systems that might provide both heat and electricity to local areas more efficiently.

Such an increase may stimulate additional requirements for coal systems, such as fluidized-bed combustion boilers and coal gasifier-combined cycle systems. These technologies are expected to be suited to smaller scale operation (50-300 megawatt), and might be used locally, satisfying the environmental need to control noxious emissions. Nuclear power systems, however, may be noncompetitive in local settings, owing to the very high costs of constructing smaller (less than 600 megawatt) reactor plants and the severe criteria for reactor siting.

Taken collectively, factors of water competition, site geology, and population density may reduce the number of suitable nuclear sites. This situation has been intensified by the Three Mile Island accident, which revealed the need for improved civil preparedness and evacuation procedures during a nuclear emergency. These added uncertainties may imply that future reactors will be located primarily on existing nuclear sites, as more strin-

gent siting restrictions eliminate marginally acceptable sites.

### Midprice Case Projections

Demand for utility electricity grew at an average annual rate of 7.3 percent between 1960 and 1973, and 3.2 percent per year over the next 5 years. A lower growth rate for demand is projected after 1978, averaging 2.6 percent yearly before 2000 and 2.0 percent after 2000. This decrease reflects the lower growth in GNP, the increase in conservation, and the growth of dispersed generation.

Capacity expansion forecasts for the utility sector through 1995 project increased coal-fired and nuclear units. Over 80 percent of electricity supply will come from coal and uranium in 2000, with oil and natural gas used mainly to meet peak demand. These trends are illustrated in Figure 5.8. The "other" category in the figure represents hydro, geothermal, biomass, wind, solar, and OTEC.

Nuclear capacity could reach 180 gigawatts electric (GWe) in the midprice case by 2000 assuming reactors operated, on the average, at 65 percent of rated capacity. (See Table 5.12.) The sensitivity cases shown in this table are discussed in the Sensitivity Analysis section.) At this level of output, nuclear reactors would provide about 26 percent of all central-station electricity generated in 2000. Assuming that economic and technical prudence dictate that reactors remain in constant or baseload service at full capacity, this level of nuclear electricity would represent about 32 percent of total baseload generation in that year.

The share of central-station generation from nuclear power is forecasted to continue to increase after 2000. By 2010, approximately 265 GWe of nuclear capacity may produce over 35 percent of all electricity generated, or nearly 42 percent of all projected baseload service. The projected contribution of light-water reactors approaches 320 GWe of operating capacity in 2020. Considering that major portions of existing capacity will be reaching retirement age by 2005, this forecast implies that approximately 14 GWe of new capacity must be deployed annually after 2000 to achieve the 320 GWe level of total nuclear capacity in the national grid. These figures assume that the average capacity factor of the nuclear system increases to 70 percent after 2000.

Several sensitivity cases for nuclear power have been examined in this analysis. The long-term nuclear forecasts for the low and high oil prices (not shown in the tables) display little variance by 2020. A greater forecast range, as indicated by the low and high nuclear supply cases (shown in Table 5.12), results when additional assumptions are imposed on the midprice case. The low nuclear supply case assumes that through 1995 the lead-times to license and build plants are longer and the costs are higher than in the base case. (See the Sensitivities of Projected Nuclear Power Capacity section of Chapter 4.) In addition, it is assumed that a higher capacity factor for the nuclear system is realized in the 21st century. The high nuclear supply case is the opposite: shorter lead-times and lower costs are assumed through 1995, and no improvement in the system capacity factor is realized after 2000. That is, the 65 percent capacity factor used through the midterm is assumed to continue throughout the forecast period. Two additional projections, based on a nuclear phaseout scenario and a high nuclear supply/high capital cost scenario (shown in Table 5.12), are discussed later.

By 2020, generation by central utility stations totals 19 quadrillion Btu, while industrial generation contributes an additional 1.4 quadrillion Btu or about 12 percent of total industrial demand for electricity. The reduced demand for central-station fission systems results in a relatively stable price of uranium fuel, and little incentive is generated for advanced fission systems such as the Liquid Metal Fast Breeder Reactor (LMFBR). Characterized by high investment costs for reactors and supporting fuel cycle facilities, the LMFBR is first deployed by 2010 and rises to a capacity of about 4 GWe by 2020. However, the uranium supply analysis for this forecast only considers resources with a forward cost of up to \$50 per pound. New, lower grade resources currently under investigation and development may mitigate the breeder incentive entirely. Finally, under current research and development planning, the deployment of fusion generating stations may actually proceed at a faster rate than the LMFBR after its projected deployment in 2020.

Table 5.13 shows electricity generation by fuel and technology. In 1978, all utility coal was used directly by conventional boilers. Between 1978 and 1995, coal consumption by conventional boilers increases 3.0 percent annually, then decreases in



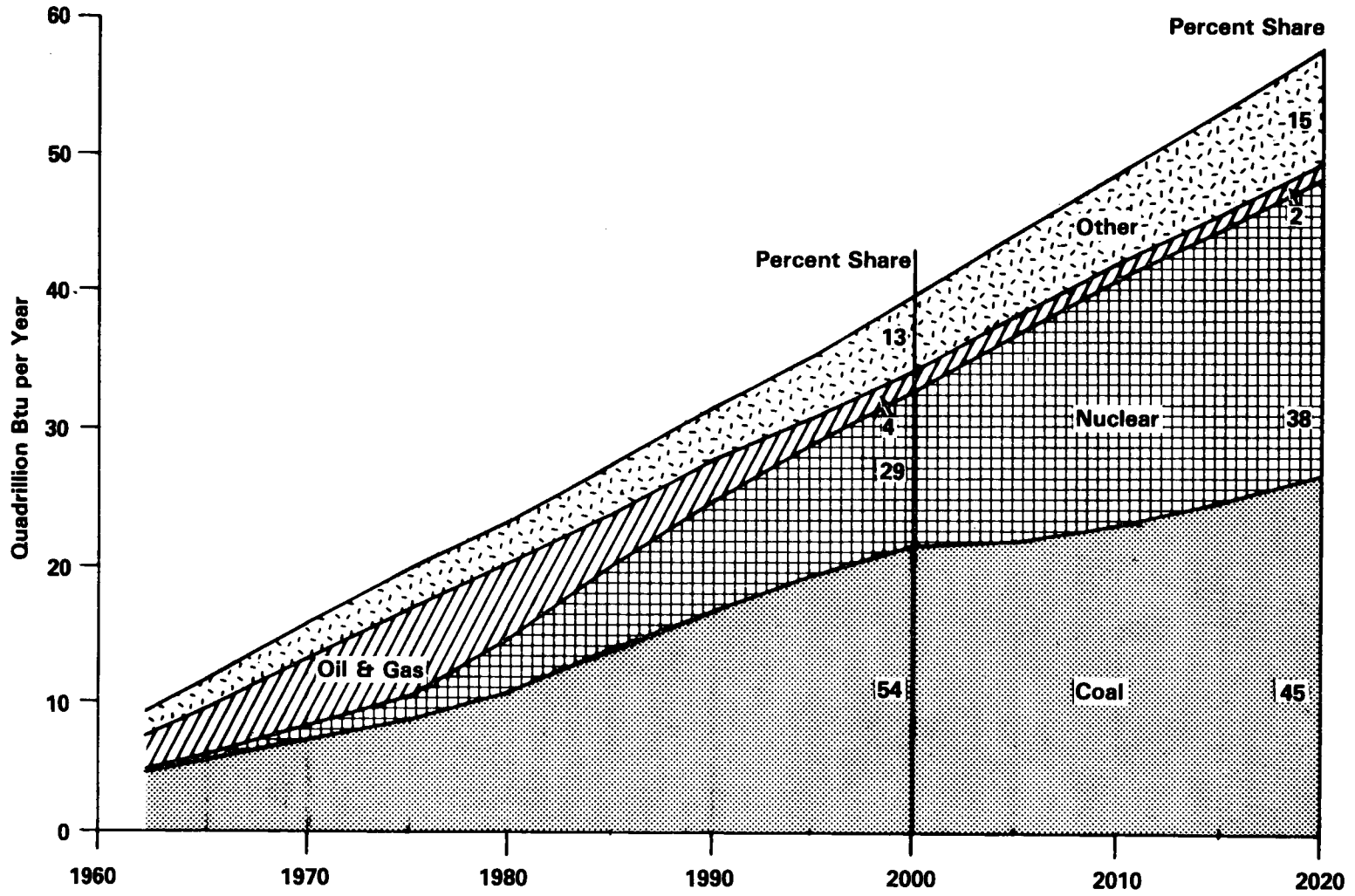

Figure 5.8 U.S. Utility Demand

later years as new coal-fired technologies emerge. By 2000, the new, more efficient coal technologies are estimated to produce 23 percent of total electricity generated from coal. This percentage increases to 60 percent in 2020. (In this analysis, it is assumed that technology advancements that solve current operational problems and reduce costs occur by the estimated date of commercial availability.)

Renewable technologies contribute 13 percent of total electricity generation by 2000 and 15 percent by 2020, with hydro and geothermal supplying approximately 77 percent of the total electricity generated by renewables in 2020. Solar and OTEC combine to contribute 19 percent of the renewable total. Wind and biomass provide the remainder. Both availability and siting affect the penetration of renewables. The facts that geothermal resources are available only in limited areas and that OTEC can be used efficiently only where large temperature differences exist between the upper and lower ocean waters limit their penetration in this analysis. The same is true for wind-generated and terrestrial solar power, which cannot be relied upon to consistently meet baseload demand.

### Sensitivity Analysis

The price of world oil has only a limited effect on the end-use demand for electricity. In the long term, nuclear, coal, and renewable technologies

supply most of the utility market and, as a result, high world oil prices do not affect its price and demand.

However, the nuclear phaseout scenario results in a lower demand for utility-generated electricity and a move to technologies fueled by coal and renewables. This sensitivity case assumes that light-water reactors will be phased out after a 30-year operating life and that only nuclear units currently under construction (and at least 10 percent complete) are allowed to complete construction and enter service. To satisfy electricity demand, coal supply must increase from 72 (medium case) to 83 (nuclear phaseout) quadrillion Btu in 2020, an annual growth rate from 2000 to 2020 of about 4 percent. This increase results in higher coal prices, which increase the cost of generating electricity. As Table 5.14 illustrates, the end-use price of electricity in the nuclear phaseout case is higher than the midprice case by nearly \$0.80 per million Btu in 2010 and, as a result, sales are lower by 0.7 quadrillion Btu in 2010 and 0.9 quadrillion Btu in 2020. Autogeneration and cogeneration supplement most of the decrease in utility-supplied electricity for the industrial sector.

In a second sensitivity case, assuming that the capital costs of new technologies will be twice the estimates currently available, the penetration of new technologies is slowed dramatically, and the requirement for conventional coal and nuclear technologies is enhanced. (For further explanation of the increased capital cost assumption, see the

**Table 5.12 Nuclear Power Forecasts Through the Long-Term  
(Gigawatts Electric)<sup>a</sup>**

Year	Middle Case Forecast and Sensitivities				
	Low Nuclear Supply	Middle Case	High Nuclear Supply	Nuclear Phaseout <sup>b</sup>	High-Nuclear High Capital Cost <sup>c</sup>
1978 .....	48	48	48	48	48
1985 .....	86	98	109	86	109
1990 .....	121	128	139	117	139
1995 .....	137	151	160	118	160
2000 .....	160	180	200	118	200
2010 .....	235	265	300	55	345
2020 .....	290	320	345	—	460

<sup>a</sup>Light water reactors operate in the middle case at 65 percent capacity factor through the year 2000, and at 70 percent capacity factor from 2010 to 2020. Heat rate is 11,000 Btu per kilowatt-hour. Capacity estimates are year-end.

<sup>b</sup>Reactors currently with less than 10 percent construction complete are cancelled—phased retirements are assumed after 30 years operating lifetime.

<sup>c</sup>New technology central station costs are doubled from the middle case values. High Nuclear Supply is assumed.

Synthetic Fuels section. Note that the capital costs for nuclear technologies are not increased.) In regard to coal technologies, the midprice scenario forecasts 77 percent of electricity generation to be produced by conventional boilers and 23 percent by new technologies in 2000. The comparable numbers in the high capital cost scenario are 98 percent conventional boiler and 2 percent new coal technologies. In 2020, conventional boilers retain 83 percent of the market in the high capital cost case, compared to 40 percent in the midprice case.

**Table 5.13 Electricity Generation by Fuel and Technology: History and Projections, Middle Case**  
(Quadrillion Btu per Year)

	1978	2000	2010	2020
<b>Coal</b>				
Conventional Boiler.....	3.3	5.8	4.7	3.8
AFB.....	0	1.2	1.9	2.6
Combined Cycle.....	0	0.5	0.9	1.3
MHD.....	0	*	0.2	1.1
Fuel Cells, Coal Gasifier....	0	0.1	0.3	0.8
Total Coal.....	3.3	7.5	8.0	9.6
<b>Oil</b>				
Oil Boiler.....	1.2	*	*	*
Oil Turbine.....	*	0.1	0.1	0.1
Fuel Cells, Oil.....	0	*	*	*
Total Oil.....	1.2	0.1	0.1	0.1
<b>Gas</b>				
Gas Boiler.....	0.9	0.2	0.1	*
Gas Turbine.....	0.1	0.1	0.1	0.2
Wind Back-up.....	0	*	*	*
Total Gas.....	1.0	0.3	0.2	0.2
<b>Nuclear</b>				
Conventional (LWR).....	0.9	3.5	5.6	6.7
Advanced (FBR).....	0	0	*	0.1
Fusion.....	0	0	0	*
Total Nuclear.....	0.9	3.5	5.6	6.8
<b>Renewables</b>				
Biomass.....	*	0.08	0.09	0.10
Solar.....	0	0.03	0.10	0.30
OTEC.....	0	0.01	0.05	0.23
Wind.....	0	0.03	0.03	0.03
Geothermal.....	0.01	0.53	0.80	1.05
Hydro.....	0.96	1.09	1.09	1.10
Total Renewables.....	0.97	1.76	2.16	2.81
<b>Total Gross Electrical Output</b>	<b>7.50</b>	<b>13.20</b>	<b>16.10</b>	<b>19.50</b>
<b>Line Loss.....</b>	<b>0.70</b>	<b>1.20</b>	<b>1.40</b>	<b>1.70</b>
<b>Total Electricity Available.....</b>	<b>6.80</b>	<b>12.00</b>	<b>14.70</b>	<b>17.70</b>

AFB = Atmospheric fluidized bed.

MHD = Magnetohydrodynamics.

LWR = Light water reactor.

FBR = Fast breeder reactor.

OTEC = Ocean thermal energy conversion.

\*Contribution is less than 0.05 quadrillion Btu.

Note: Totals may not add due to independent rounding.

The level of renewables also is lower in the high capital cost scenario. In 2020, they contribute 15 percent of total electrical generation inputs in the medium case, but only 11 percent in the high capital cost case. Because solar, OTEC, and wind have decreasing contributions, biomass, which shows a small contribution in 1975, takes a larger share of the renewable market. To compensate, nuclear takes a much larger share of the utility market (49 percent in 2020). Growth in nuclear fuel must increase at an annual rate of 5.4 percent from 2000 to 2020 in this scenario, compared to 3.4 percent in the midprice case.

A third sensitivity scenario combines the assumptions of the above scenarios, that nuclear reactors are phased out and that capital and operating costs are twice the midprice case value for new (utility and synthetic) technologies. This scenario results in higher end-use prices and a substantially lower demand for utility-generated electricity than the midprice case. In 2020, the end-use price of electricity is over 30 percent higher than the midprice case, resulting in an increase of approximately \$5.20 per million Btu. Electricity sales are lower for both the commercial sector (by 18 percent) and industrial sector (by 25 percent). Total residential demand for electricity is lower but purchases from utilities are slightly higher (0.2 quadrillion Btu) than in the midprice case, because less electricity is produced by distributed photovoltaics. This scenario results in substantially higher prices of electricity compared to the nuclear phaseout scenario because the new, more efficient coal technologies are no longer as economically competitive.

These results show that after 2000, electricity will be generated using a combination of coal, nuclear, and renewable resources. Because renewables cannot satisfy the entire demand for electricity, coal and nuclear technologies must be used to supply a major portion of that demand. To obtain the coal, the utility industry must compete with synthetic fuel processing plants and industrial users for available coal supplies.

These sensitivity cases, shown in Table 5.14, highlight an important result of the long-term analysis. Electricity consumers could tolerate a nuclear phaseout if the assumed capital costs in the midprice case prove accurate. If the higher capital cost estimates prove more correct, the resulting lower level of electricity generation from new technologies could be offset by an active nuclear program. Nuclear power thus appears to

**Table 5.14 Sensitivity of Electricity Fuel Consumption, Generation, and Sales Projections for 2000–2020**  
(Quadrillion Btu per Year)

	1978	Middle Case			Nuclear Phaseout			High Capital Costs	Nuclear Phaseout Plus High Capital Costs
		2000	2010	2020	2000	2010	2020	2020	2020
<b>Fuel Usage</b>									
Coal .....	10.3	21.4	22.6	26.2	23.1	30.3	36.1	22.6	36.5
Oil .....	3.9	0.4	0.3	0.3	0.2	0.1	0.2	0.3	0.3
Natural Gas .....	3.3	1.1	0.9	0.8	1.2	1.0	0.8	0.8	0.7
Nuclear .....	3.0	11.3	18.1	21.8	7.4	3.3	0.1	32.0	0.1
Renewables .....	3.0	5.3	6.5	8.4	5.6	8.1	11.8	7.1	7.5
<b>Electrical Generation by Fuel Type</b>									
Coal .....	3.3	7.50	8.04	9.59	8.27	11.34	14.23	7.94	13.37
Oil .....	1.2	0.11	0.09	0.09	0.06	0.04	0.06	0.09	0.09
Natural Gas .....	1.0	0.31	0.24	0.22	0.35	0.26	0.20	0.21	0.18
Nuclear .....	0.9	3.49	5.60	6.78	2.28	1.03	0.03	9.98	0.03
Hydro .....	1.0	1.09	1.09	1.10	1.07	1.06	1.06	1.11	1.06
Biomass .....	*	0.08	0.09	0.10	0.08	0.13	0.17	0.18	0.18
Solar .....	0	0.03	0.10	0.30	0.12	0.33	0.84	0.01	0.11
OTEC .....	0	0.01	0.05	0.23	0.04	0.35	0.79	0.01	0.09
Wind .....	0	0.03	0.03	0.03	0.04	0.04	0.03	0.01	0.02
Geothermal .....	0.01	0.53	0.80	1.05	0.53	0.80	1.05	1.05	1.05
<b>Sales</b>									
Residential .....	2.3	3.4	3.5	3.3	3.3	3.3	3.0	4.2	3.5
Commercial .....	1.8	2.5	3.2	3.9	2.5	3.1	3.7	3.9	3.2
Industrial .....	2.7	5.8	7.7	10.2	5.7	7.3	9.7	10.3	7.7
Transportation .....	*	0.2	0.3	0.3	0.2	0.3	0.3	0.3	0.3
Total Electricity Sales .....	6.8	12.0	14.7	17.7	11.7	14.0	16.8	18.7	14.7
<b>Price to End-Use Sectors</b> (1979 dollars per million Btu)									
Residential .....	12.69	16.38	15.96	16.25	16.86	16.77	17.02	17.46	21.44
Commercial .....	12.84	16.71	16.30	16.59	17.20	17.11	17.36	17.80	21.78
Industrial .....	8.34	12.82	12.41	12.69	13.31	13.22	13.46	13.91	17.89

\*Contribution is less than 0.005 quadrillion Btu.  
OTEC = Ocean thermal energy conversion.  
Note: Totals may not add due to independent rounding.

be insurance against the possibility of higher future costs of alternate technologies.

Table 5.14 shows that a nuclear phaseout results in a weighted average increase of only 5 percent in the price of electricity to the end-use sectors over the midprice level in 2020. This can be compared to an average increase in electricity prices of 26 percent when the nuclear phaseout assumption is added to the high capital cost assumption.

### New Utility Technologies

In the long term, renewable energy resources and advanced coal technologies will become significant sources of energy for electricity generation. The rising costs of conventional fuels encourage

the development of alternative, renewable energy resources, and environmental regulations encourage the development of cleaner, more efficient coal technologies. The following paragraphs describe new processes for electricity generation.

### Geothermal

Geothermal powerplants use the thermal energy generated within the Earth's core to produce electricity. Water may be naturally present or artificially injected into hot dry rocks. Only geothermal resources with water naturally present are currently being developed.

Dry-steam resources (superheated steam) in the United States are developed for electric power generation at The Geysers field in northern Cali-

fornia. The superheated geothermal steam directly drives turbine generators and is then condensed in cooling towers and reinjected into the field. Another dry-steam resource was recently discovered at Dixie Valley, Nevada.

In wet-steam geothermal wells, the steam is embodied in saturated brine under pressure. In the binary cycle process, the hot brine, with the pressure maintained, passes through an evaporator that boils a working fluid (water, isobutane, or freon). This working fluid drives the turbine, is condensed, and is recycled to the evaporators. The brine is reinjected into the geothermal field. An alternative procedure is to flash the steam from the brine by reducing the pressure over the brine and to drive a turbine with the steam. The flashed steam is condensed, remixed with the brine, and reinjected into the geothermal field. Wet-steam resources exist at the Imperial Valley, California; Raft River, Idaho; and Valles Caldera, New Mexico.

Geothermal powerplants will be reliable sources of baseload power. The main limitation of dry-steam geothermal technology is the restricted resource availability. The wet-steam resource is more widespread, but the entire binary cycle wet-steam technology remains unproven. Commercialization of wet steam is expected to begin between 1985 and 1990.

### **Solar Thermal**

The solar thermal powerplant consists of a field of heliostats (mirrors that can track the sun by rotating along two axes) that focus direct solar radiation onto a tower-mounted receiver. A central receiver uses a standard Rankine cycle system that uses radiation to produce steam to drive a generator. Several other conversion cycles are now being studied. Research by the Department of Energy also includes investigation of receivers using liquid metals, salts, or water as the heat-transfer medium.

Reduction of the cost of heliostats is crucial for achieving a competitive, mature technology. Also, the operating and maintenance costs are expected to be high owing to the large number of moving parts and the need to keep the heliostat surfaces free of dirt.

The solar thermal powerplants are designed for intermediate load generation and require a backup system for reliable electricity production. This technology should be commercially available by 1995.

### **Wind**

A wind-energy conversion system converts the energy of the wind to rotational forces, which are typically transferred by a shaft to a direct current electric generator. The direct current is converted into alternating current for distribution.

Four designs of large-scale wind systems are currently being developed for utilities: a vertical-axis wind turbine, with a rated capacity of 500 kilowatts in a 30-mph wind, and three horizontal-axis systems, with capacities of 1500–2500 kilowatts rated at wind speeds ranging from 19 to 28-mph. Research is directed toward developing large systems with competitive capital costs when produced in quantity.

Large systems for wind-energy conversion are designed for integration into an electric utility system, with appropriate backup capacity. The benefits include fuel savings as well as partial capacity displacement of conventional electrical generating technologies. Wind systems are expected to be available for commercial operation after 1988.

### **Ocean Thermal**

The ocean thermal energy conversion (OTEC) process takes energy from tropical surface waters to generate electricity and rejects waste heat to the colder subsurface waters. In one design, warm seawater heats ammonia in an evaporator, and the ammonia vapor is expanded in a turbine that is coupled with an a.c. or d.c. generator. Cold seawater cools the exhaust, which is pumped back to the evaporator to complete the cycle. Research on three versions of ocean thermal technologies is being federally funded.

The typical OTEC generating plant will be a floating ocean vessel containing modular components. The electricity produced will be transmitted to an onshore substation by standard underwater cable. Potential sites for this technology include the Gulf of Mexico, the Gulf Stream off the U.S. Atlantic Coast, the Caribbean Sea off Puerto Rico, and the Pacific Ocean off Hawaii. However, several major development problems remain to be solved.

### **Solar Photovoltaic**

Solar cells are semiconductor devices that generate a flow of electricity when exposed to sunlight. A solar array can consist of flatplate silicon

collectors supplemented by a tracking system. Direct-current cable interconnects the arrays in series to produce the d.c. output voltage required. The solar array equipment constitutes a significant part of the total cost.

The Department of Energy is currently sponsoring research to decrease the cost of the solar cells from the current range of \$12.40 to \$37.10 per peak watt output to a mature cost of \$0.74 per peak watt. Cleaning the array panels, which could account for 30 to 40 percent of the operating and maintenance costs, is required because power reductions of up to 35 percent may result if particulates accumulate over several months.

Weather conditions are a major factor in the design and performance of photovoltaic systems. Plants used for intermediate load are expected to be commercially available by 1995. Baseload plants with storage should be available later.

### **Atmospheric Fluidized-Bed Combustion**

In atmospheric fluidized-bed (AFB) boilers, ground coal is mixed with limestone and combusted with air at atmospheric pressure. The ratio of coal to limestone in the bed depends on the sulfur content of the coal. Sulfur oxides produced during combustion react with the limestone to produce dry calcium sulfate and sulfite, which are removed from the bed with the ash. An AFB boiler is expected to be more energy efficient than a standard coal boiler, with equivalent control of emissions.

AFB powerplants are designed to operate as baseload units, because operating below capacity causes a severe drop in efficiency. The technology should become commercially available by 1990.

### **Fuel Cells**

A fuel cell powerplant consists of a fuel processor, the fuel cell, and a power conditioner. In the fuel cell, which consists of electrodes connected by a solid or liquid electrolyte, chemical reactions occur that produce electricity. Hydrogen, processed from a hydrogen-rich fuel gas, reacts with oxygen, releasing electrons and a water byproduct. The d.c. electric power is converted to a.c. power by the power conditioning unit.

Three generations of fuel cells are currently under development: phosphoric acid fuel cells are being tested in a demonstration plant; molten-carbonate fuel cells are at the pilot-plant level; and

solid electrolyte fuel cells are now in a preliminary stage of development.

Fuel cells with gaseous or liquid fuels are best applied to peak- or intermediate-load applications because of their rapid startup, ease of varying their output by varying the fuel feed rate, and high efficiency independent of utilization rate. Fuel cells fueled by coal through a coal-gasification unit will be used for baseload demand because of their higher capital costs. Phosphoric-acid fuel cells are expected to be commercially available after 1985. The molten-carbonate fuel cells are projected to be commercially available after 1990. Fuel cells combined with a coal gasifier will have later commercial startup dates.

### **Magnetohydrodynamics**

Magnetohydrodynamics (MHD) is a process for direct generation of electricity from coal. In combination with a conventional steam powerplant, it offers substantially higher efficiency than other coal-fired technologies. The MHD generator produces electricity by the interaction of a high-velocity, electrically conducting gas with an intense magnetic field. This gas is produced by burning coal with preheated air and is made electrically conductive by adding a small amount of potassium salt. To extract power, the voltage differences induced in the gas are tapped by placing electrodes in contact with the gas. The heat content left after passing through the MHD generator is then used to fire a conventional steam powerplant.

The magnetohydrodynamic technology, if successfully developed, would be used for baseload operation because of its high efficiency and high capital cost. The air emissions from this system are comparable to those from a conventional coal-fired plant equipped with modern abatement technology. Also, about 220,000 tons of solid slag waste may be produced per year by a 1000-megawatt plant. This technology is not expected to become commercially available until 2005.

### **Biomass**

A powerplant using biomass fuel is similar to a conventional coal-fired steam electric plant with modifications in fuel handling and boiler design to compensate for the lower heating value and burning rate. Biomass consists of hogged wood, sawdust, mill waste, and agricultural field wastes.

Processes for compacting and pelletizing loose wood and waste material from agricultural cellulose to be burned in wood-fired boilers are being developed.

The major technical problem associated with wood-fired powerplants is the long-term reliability of wood supplies having a consistent quality. Several small facilities are projected to begin operation in the early 1980's. This technology is currently available for commercial orders.

## Synthetic Fuels

Synthetic fuels offer a long-term means to supplement diminishing oil and natural gas supplies. This section discusses synthetic liquids produced from coal and biomass, and synthetic high-Btu gas (synthetic "natural" gas) produced from coal. The use of low- and medium-Btu gas is discussed in the Electricity Generation and Industrial Demand sections.

It is assumed that currently proven and advanced technologies to produce synthetic coal liquids and high-Btu gas will cost over \$1.3 billion (1979 dollars) for a 250-billion Btu-per-day plant. These plants require approximately 8 years for planning and construction. A commercial high-Btu gas plant that is expected to have a volume of 125 million cubic feet per day, is being built by a consortium of companies in North Dakota and is expected to be in operation by 1985. Other commercial technology plants are assumed available in 1990, and advanced technology plants are assumed available in 1995. These are assumed to be mine-mouth plants; hence, no significant coal transportation cost is incurred. The assumed cost of bringing water to a western plant plus the cost of shipping synthetics from the plant to a demand center is similar to the cost of shipping the coal to a plant with an adequate water supply near a demand center.

Synthetic liquids production in this forecast includes synthetic crude oil, boiler fuel, methanol (all from coal), and alcohol (from biomass). A discussion of these technologies is given at the end of this section.

Demand for liquids increases slightly over the forecast period for each scenario (or world oil price): low, middle, and high, as previously mentioned. This increasing demand for liquids along with depletion of domestic oil reserves creates a void that can be filled by either imported oil or

synthetic liquids production. Except for the low oil price case, synthetic liquids production is more economical and, as a result, becomes the primary source of liquids supply.

Total synthetic liquids increase from 2.2 quadrillion Btu in 2000 to 16.7 quadrillion Btu in 2020, an annual growth rate of 10.6 percent (midprice case). In 2000, alcohol from biomass is 36 percent of synthetic liquids supply. By 2020, the biomass share is down to 7 percent because of the growth in liquids from coal. The use of biomass shifts toward direct combustion by industry.

The contributions from the various sources of liquids are sensitive to the assumed price of world oil. In terms of total liquids demand in 2020, imports are 18 percent in the midprice scenario as compared with 53 percent in the low price scenario. Synthetics, however, decrease from 43 percent (midprice case) to 22 percent (low price case), because they are not as economically competitive at the low world oil price. The contribution from shale oil also decreases from 15 to 6 percent from the midprice to the low price case.

An important result of this analysis is that the potential demand for synthetic coal liquids exceeds industry's maximum production capacity in 2000. Synthetics plants are needed to meet this demand, but construction rates are limited by planning and construction leadtimes. Also, maximum rates of growth are assumed in this analysis, but the actual rates could be higher or lower owing to uncertainties regarding development of the synfuels program. The synthetics industry is assumed to be well established by the post-2000 period. Projected high growth rates for coal liquids between 2000 and 2020 indicate that this fuel is economically attractive relative to other domestic liquids production and imported oil.

Table 5.15 shows a sensitivity case that assumes that the capital and nonfuel operating costs of many new technologies would be twice as expensive as the currently estimated base-case cost. Cost estimates for some of the technologies considered new are believed to be more certain and are not increased in this analysis. These include nuclear, geothermal, shale oil, and the direct combustion of biomass. The higher costs for the technologies noted on Table 5.15 inhibit the production of synthetics. Total synthetics production in 2020 is projected to be 16.7 quadrillion Btu in the middle case, compared to 8.4 quadrillion Btu in the high capital-cost case. Imported oil replaces the production of synthetic liquids.

Another sensitivity case shown below combines the assumptions used in the high world oil price case and the high capital cost case, as described above. The results indicate that synthetic fuels are economically attractive at double their assumed costs when high world oil prices are assumed, but they are not competitive in the high capital cost case when the middle world oil price is assumed.

### Sensitivity to High Capital Cost

Coal Synthetics Production (Quadrillion Btu per Year)	2000	2010	2020
High Capital Cost Case	0.3	1.1	4.0
High World Oil Price Case	1.5	6.8	17.5
High Capital Cost, High World Oil Price Case	1.4	4.9	12.9
Oil Imports (Quadrillion Btu per Year)			
High Capital Cost Case	15.0	13.7	18.0
High World Oil Price Case	8.4	3.4	2.0
High Capital Cost, High World Oil Price Case	8.1	3.9	3.6

The long-term projections of the market penetration of new technologies are based on estimates of the costs of mature technologies developed by qualified engineering firms, but without reference to specific sites. The estimated capital costs of pioneer plants are assumed to be 1.85 times the mature costs, with the costs of later plants decreasing over time to mature costs. However, this adjustment for the uncertainty concerning the cost of new technologies may be insufficient. The above sensitivity analysis is an attempt to bracket the effect of this uncertainty. In this analysis, pioneer plants are assumed to cost 3.7 times the estimated mature plant cost, and the costs of later plants are assumed to decrease over time to twice the estimated mature cost in the midprice case.

On the basis of a study of the final capital costs of pioneer plants relative to the initial engineering cost estimates, the sensitivity analysis considered here may be closer to reality than the midprice forecast.<sup>9</sup> The final costs of the plants studied were roughly two to four times the initial engineering

<sup>9</sup> Edward W. Merrow, Stephen W. Chapel, and Christopher Worthing, *A Review of Cost Estimation in New Technologies: Implications for Energy Process Plants* (Santa Monica, CA: The Rand Corporation, 1979), document R-2481-DOE.

cost estimates, after correcting for the effects of inflation. The average cost escalation multiplier was about three. The study only examined the capital cost of pioneer plants, so information is not available on the final mature cost of plants relative to the initial cost estimate for the pioneer plant.

That synthetic liquids penetrate more rapidly in these forecasts than syngas is directly related to the prices of their domestic and imported counterparts. High-Btu gas demand is satisfied primarily by domestic sources, so its price is based on domestic costs rather than the higher import prices. Imported oil, however, is the marginal source of liquids supply and its price dominates the crude oil price. If more gas were demanded than the projections show, natural gas production would increase. Such an increase would raise the price of gas and allow more syngas to penetrate the market.

Liquid fuel use continues to grow throughout the forecast period because alternative fuels can neither replace liquids in the transportation sector nor satisfy the demands for petrochemical feedstocks and lubricating oils. High-Btu gas, however, competes directly with coal and/or electricity in its primary applications. As a result, total demand for high-Btu gas decreases post-1995, despite its advantages in some uses. (See the Energy Supply section.) A simplified example of the relative efficiency of syncrude, syngas, and electricity follows.

A comparison of residential end-uses of coal converted to either electricity, syngas, or syncrude shows the first two to be more energy efficient. When one unit of coal is converted to either syncrude, syngas, or electricity and the output is used for space heat, approximately 0.55 units of heat result from syngas and electricity (considering a heat pump), while 0.42 units result from syncrude. In particular:

- One unit of coal produces 0.65 units of syncrude, which yields 0.42 units of space heat. (The efficiency for an oil space heater is assumed to be 0.64 in 2020.)
- One unit of coal produces 0.69 units of syngas, yielding 0.54 units of space heat. (The efficiency of a gas space heater is assumed to be 0.82 in 2020, and the transportation fuel and loss is approximately 4 percent.)
- One unit of coal produces 0.37 units of electricity, yielding 0.57 units of space heat.



**Table 5.15 Sensitivity of Energy Production to High Capital Equipment Costs of New Technologies, 2000–2020**  
(Quadrillion Btu per Year)

	1978	Middle Case			High Capital Costs		
		2000	2010	2020	2000	2010	2020
<b>Supply</b>							
Coal .....	15.0	38.2	49.7	71.6	36.9	39.5	48.2
Natural Gas .....	20.5	17.1	14.8	12.2	17.1	15.3	13.6
Domestic .....	19.5	16.4	14.6	12.1	16.3	15.1	13.3
Imports .....	1.0	0.7	0.2	0.1	0.8	0.2	0.3
Oil .....	38.5	33.6	29.0	21.9	35.6	35.6	34.9
Domestic .....	20.7	20.5	20.6	15.0	20.6	21.9	16.8
Imports .....	17.8	13.1	8.4	6.8	15.0	13.7	18.0
Nuclear Fuel .....	3.0	11.3	18.1	21.8	11.3	22.6	32.0
<b>Production from New Technologies</b>							
<b>Liquids</b>							
Synthetic Crude (Coal) <sup>a</sup> .....	0	1.00	3.50	8.00	0.26	0.97	1.70
Methanol (Coal) <sup>a</sup> .....	0	0.30	1.50	5.00	0.02	0.08	0.16
Boiler Fuel (Coal) <sup>a</sup> .....	0	0.11	0.93	2.48	0.01	0.05	2.09
Alcohol (Biomass) <sup>a</sup> .....	0	0.80	1.59	1.24	0.08	0.11	0.11
<b>Gases</b>							
High-Btu (Coal) <sup>a</sup> .....	0	0.14	0.50	1.27	*	0.02	0.10
<b>Utility Electricity</b>							
Combined Cycle <sup>a</sup> .....	0	0.49	0.89	1.34	0.05	0.11	0.28
AFB <sup>a</sup> .....	0	1.15	1.90	2.60	0.13	0.29	0.70
MHD <sup>a</sup> .....	0	0.01	0.20	1.09	0	0.02	0.24
Fuel Cells, Coal Gasifier <sup>a</sup> .....	0	0.08	0.31	0.75	0.01	0.03	0.13
Fuel Cells, Oil <sup>a</sup> .....	0	0.02	0.02	0.02	0.01	0.01	0.01
Fast Breeder Reactor .....	0	0	0.03	0.08	*	0.07	0.32
Biomass .....	*	0.08	0.09	0.10	0.08	0.13	0.18
Solar <sup>a</sup> .....	0	0.03	0.10	0.30	*	*	0.01
OTEC <sup>a</sup> .....	0	0.01	0.05	0.23	0	*	0.01
Wind <sup>a</sup> .....	*	0.03	0.03	0.03	*	0.01	0.01
<b>Decentralized Renewables</b>							
Solar .....	<sup>b</sup> 0.01	0.49	1.07	1.86	0.50	1.09	1.91
Geothermal .....	*	0.28	0.74	1.35	0.28	0.74	1.35
Biomass (Industrial) .....	<sup>b</sup> 1.3	3.98	4.46	5.18	3.98	4.53	5.18
Photovoltaic (Residential) <sup>a</sup> .....	0	0.11	0.38	0.93	*	*	0.02
<b>Industrial Electricity Generation</b>							
Autogeneration .....	0.27	0.49	0.51	0.52	0.49	0.53	0.62
Cogeneration .....	<sup>c</sup>	0.42	0.68	0.91	0.38	0.54	0.75

<sup>a</sup>Capital costs and non-fuel operating costs are doubled for the High Capital Costs scenario.

<sup>b</sup>Estimated.

<sup>c</sup>Included in autogeneration.

\*Less than 0.005 quadrillion Btu.

AFB = Atmospheric fluidized bed.

MHD = Magnetohydrodynamics.

OTEC = Ocean thermal energy conversion.

Note: Totals may not add due to independent rounding.

(The efficiency of an electric heater with heat pump is assumed to be 1.7 in 2020, and the transmission loss is approximately 10 percent.)

### Synthetic Coal Technologies

Conversion processes for changing coal into gaseous and liquid fuels are not new. The development of coal gasification led to the age of gaslight illumination in the nineteenth and early twentieth centuries, when every major city in Europe and North America had a gas manufacturing plant.

Coal liquefaction development began in 1913 when the German chemist, Friedrich Bergius, found that coal could be liquefied if treated with hydrogen at 800°F under a pressure of 100 atmospheres. It is reported that 18 Bergius plants produced 90,000 barrels of oil per day during World War II. These plants supplied Germany with 85 percent of its aviation fuel, as well as substantial quantities of diesel oil, lubricating oils, and motor gasoline.

In 1920, the Fisher-Tropsch liquefaction process was developed. In that process, coal is gasified to produce carbon monoxide and hydrogen, and then

the gas is catalytically converted to a mixture of organic chemicals. This process was used in Germany during World War II to produce a variety of chemicals including alcohols, oils, and waxes.

The major existing coal liquefaction facilities are in the Republic of South Africa, where a plant began commercial operation in 1956 using Lurgi gasifiers for coal conversion to gas, and Fischer-Tropsch synthesis units for gas conversion to fuels and chemicals. Since 1962, the original plant has been expanded to an integrated petrochemical complex that provides pipeline-quality gas. A second plant, much larger than the first, is now under construction and should begin operating this year. It is reported that the two plants will supply 40 percent of the Republic of South Africa's gasoline requirement.

### Gasification Techniques

Current coal gasification efforts are mostly extensions of the old producer gas and water gas processes, where gas is produced by passing air and steam through a bed of incandescent carbon to form hydrogen and carbon monoxide. These processes have had major refinements, such as the development of high-pressure reactors and the use of oxygen and catalysts to increase yields and the heat content of the gas.

Gasification products are categorized as low-Btu, medium-Btu, and high-Btu gases. Low-Btu gas, which has a heat content of from 100 to 250 Btu per cubic foot, results when air used in the gasification process produces a gas consisting mostly of carbon monoxide, hydrogen, and nitrogen. When oxygen is used rather than air, the resulting medium-Btu gas has a heat content of 300-500 Btu per cubic foot after the removal of carbon dioxide and water. An additional step, called methanation, by which the carbon monoxide and hydrogen in the gas are catalytically reacted to form methane, results in the production of high-Btu gas, or synthetic natural gas, with a heat content of 900-950 Btu per cubic foot.

Several gasification processes are now in commercial operation, including: the Lurgi, the Koppers-Totzek, the Winkler, and the Wellman-Galusha. Advanced processes under development include the Bi-gas, the CO<sub>2</sub> Acceptor, the Hygas, the Molten Salt Process, and processes for producing low- and medium-Btu gas for electric power generation.

Another method of coal gasification under development is in situ or underground gasification. The objective of underground gasification is to convert coal to a combustible gas by conducting the appropriate chemical processes underground. Like surface gasification processes, air injections produce a low-Btu product gas, whereas steam-oxygen injections can upgrade the gas to medium-Btu quality.

In this analysis, a representative commercial and a representative advanced process are considered. Both processes are assumed to be able to use any type of bituminous coal or lignite, other than coking coals, as feedstock.

### Liquefaction Techniques

The three basic approaches to coal liquefaction are pyrolysis, indirect conversion, and direct liquefaction. Each process can convert coal into a variety of liquids that can be used as fuel or chemical feedstocks. Processing techniques vary considerably, as do yields and characteristics of the end products.

The major use of pyrolysis is in coke ovens to produce metallurgical coke as the primary product as well as significant quantities of liquids.

In indirect conversion, such as in the Fisher-Tropsch process, coal is first gasified to produce synthesis gas. This gas is then purified and, in some instances, a shift reaction is performed to increase its hydrogen content. The resulting synthesis gas can then be chemically reacted to produce methanol or a number of chemical intermediates that can be further upgraded to gasoline.

Direct liquefaction, or hydroliquefaction, involves the direct processing of coal at high pressure and moderate temperature in the presence of hydrogen. All direct processes stem from the Bergius process previously mentioned. However, pressures and temperatures have been increased, and catalysts are used in some processes to speed the rate of reaction.

In direct liquefaction, characteristics of the products can be changed by varying temperatures, pressures, and residence time in the reactor. At low temperature, hydrogen pressure, and short residence time, the product mainly consists of heavy oils suitable for use as boiler fuel. At high temperature, pressure, and longer residence time, the heavier products are converted to lighter fractions.

Liquids derived from direct breakdown and hydrogenation of the coal molecule are principally aromatic hydrocarbons, but naphthenic and aliphatic compounds are also obtained.

The Fischer-Tropsch process is in commercial operation, and improvements are under development. Direct coal hydrogenation processes under development include the Solvent Refined Coal I and II (SRC I produces a solid and SRC II a liquid boiler fuel), the H-Coal, and the Donor Solvent. The production of methanol from medium-Btu gas is an established technology, and a process for converting methanol to gasoline has recently been developed.

The Fisher-Tropsch process, a representative direct hydrogenation process, and a methanol process—producing syncrude, boiler fuel, and methanol, respectively—are considered in this analysis. The production of ethanol from grain and methanol from wood and crop residues is also considered.

### Potential Plant Sitings

The establishment of a coal-based synthetic fuels plant requires not only a large reserve of suitable coals that will be available throughout the life of the plant, but also large supplies of water.

A synthetic natural gas plant, producing 250 million standard cubic feet per day of gas with a heat content of at least 900 Btu per cubic foot, requires between 5- and 10-million tons of coal per year, depending upon the quality. Water requirements also vary tremendously according to the process, and a plant of this size may require from 4 to 7 million gallons of water per day.<sup>10</sup> Such quantities of water can place a significant incremental demand on local sources, especially in water-scarce western regions where large-scale coal mining, gasification, and liquefaction developments are planned. Nonetheless, the combination of coal and water availabilities will determine the amount of synthetic fuels development in any area.

### Alcohols

Alcohols produced from biomass are expected to contribute directly to the supply of liquid fuels.

<sup>10</sup> R. F. Probst and H. Gold, *Water in Synthetic Fuel Production: The Technology and Alternatives* (Cambridge, Massachusetts: The Massachusetts Institute of Technology, 1978) pp. 244-277.

Ethanol (grain alcohol) is now being blended into gasohol, and methanol (wood alcohol) is likely to be used in the future.

Ethanol has an energy content by volume of about two-thirds that of gasoline. A 5- to 15-percent blend of ethanol in gasoline can be burned effectively in the current generation of automobiles without any modifications. The present and most likely future process for producing ethanol is the fermentation and distillation process. This process limits the feedstock material to those with a high sugar content, including small grains. The high cost of these materials is substantially offset by the value of the byproduct as animal feed. Plant capacities can range from 1 to nearly 70 million gallons of ethanol per year. There is some evidence that smaller, on-farm facilities may yield a lower cost product for farm use.

Methanol has an energy content about one-half that of gasoline by volume. Like ethanol, it can be blended with gasoline with about a 90 percent gasoline content. A disadvantage is that some minor modifications are required on automobile engines to allow methanol use. The major advantage of methanol is that the conversion process will accept wood, crop residues, and other lower grade feedstocks that make up the bulk of the biomass resource base.

Production of methanol from biomass is achieved in a two-step process similar to the coal-to-methanol procedure. Efficiencies for this process are somewhat higher than the ethanol process, ranging from 45 to 60 percent.

It is technically feasible to convert the cellulose in woody feedstocks to sugar through acid hydrolysis. The sugar can then be fermented to produce ethanol, but this process is not well developed and is costly.

## ENERGY SUPPLY

Projections of the supply of energy resources to 2000 and beyond depend upon estimates of availability and costs that are increasingly uncertain relative to those of the midterm projections. The nature and degree of this uncertainty varies substantially among kinds of resources.

The role of conventional oil and gas resources in total energy supply is projected to decline over the forecast period as depletion continues. In contrast, coal remains an abundant source of energy at

reasonable costs. Enormous resources of coal, many times more than the projected demand through 2020, have been identified by the U.S. Geological Survey.<sup>11</sup> Coal is, thus, an attractive alternative for future energy supplies. Estimates of development and mining costs used in this analysis are based on currently available technologies and costs, but future costs could be substantially higher. Factors for which costs are uncertain include environmental protection, mine health and safety, relative wage escalation, coal transportation, and improved technology benefits.

Both availability and cost of crude oil and natural gas are highly uncertain. By 2000, most of the projected production of conventional oil and gas will be from reservoirs that have not yet been found. The uncertainty of availability is shown by the ranges of the estimates of undiscovered, recoverable resources by the U.S. Geological Survey for 1975.<sup>12</sup> These ranges, from 95- to 5-percent probability, are 50 to 127 billion barrels of crude oil and 322 to 655 trillion cubic feet of natural gas. Production beyond 2000 will depend on how much actually exists and is found. If the lower estimates are correct, production would be substantially below the projected levels. Enhanced recovery of oil and enhanced recovery of natural gas from unconventional sources will depend on the development of recovery technologies, which are still largely experimental, and the quantity of the resources that can actually be economically recovered using these technologies.

Vast quantities of oil shale are known to exist in Colorado, Utah, and Wyoming, but the costs of mining, extraction, and upgrading this shale are high and uncertain enough to hold in abeyance the initiation of commercial production. Also, the future rate of shale oil production may be restricted because of environmental impacts and limited water availability.

Proved resources of uranium will probably have been exploited by the turn of the century. Production projected beyond 2000 is increasingly from estimated probable and possible resources.

Mean value estimates of cost and availability are used for the projections of energy supply to

2020, and several of these uncertainties are investigated through selected sensitivity analyses.

The estimated availability and cost of production of these resources, and their cumulative development to 2020, are summarized in Figure 5.9. These supply curves represent the marginal cost per million Btu of production associated with each quadrillion Btu of additional resources committed to production. Lower cost resources are assumed to be developed first. When a mine is opened, the entire future production of that mine is assumed to be committed. The horizontal scale represents the cumulative commitments of a resource in quadrillion Btu from 1975 to some future date.

The prices shown in Figure 5.9 do not include the rent payment. In the long-term analysis, an economic rent is added to the marginal cost of a depletable resource to compensate resource owners for starting production now instead of delaying production for higher future prices. Because a unit of a depletable resource can be produced only once, a resource owner is assumed to decide, on the basis of future prices, when production would be most advantageous. The rent paid to the resource owner is the difference between the present value of what he could receive during the most advantageous production period and what he can receive now.

Estimated production from mines or wells in operation in 1975 is excluded from the producible resources shown on the supply curves, which represent only the cost of additional development. The Prudhoe Bay field of Alaska is included, however, because production had not begun in 1975.

The cost of coal per million Btu of output rises relatively slowly over the expected range of development to 2020, while the cost of oil and gas rise much more sharply. (See Figure 5.9.) The producible resources of oil and gas are much smaller than those of coal, but the rate of development is higher, so the resources of oil and gas are projected to be substantially developed by 2020.

The shale oil supply curve is not shown because it is not strictly comparable to the others. Shale oil development in this analysis is limited to the relatively high-grade resources of the "mahogany zone," because of the possible environmental impact of large-scale development in a relatively limited area. An unrestricted supply curve would result in the projection of more production of shale oil and less of coal liquids after 2000, with the total of the two essentially unchanged.

<sup>11</sup> U.S. Geological Survey, Bulletin No. 1412, "Coal Resources of the United States, January 1, 1974," Reston, VA, 1975.

<sup>12</sup> U.S. Geological Survey, Circular 725, "Geological Estimates of Undiscovered Recoverable Oil and Gas Resources in the United States," Reston, VA, 1975.

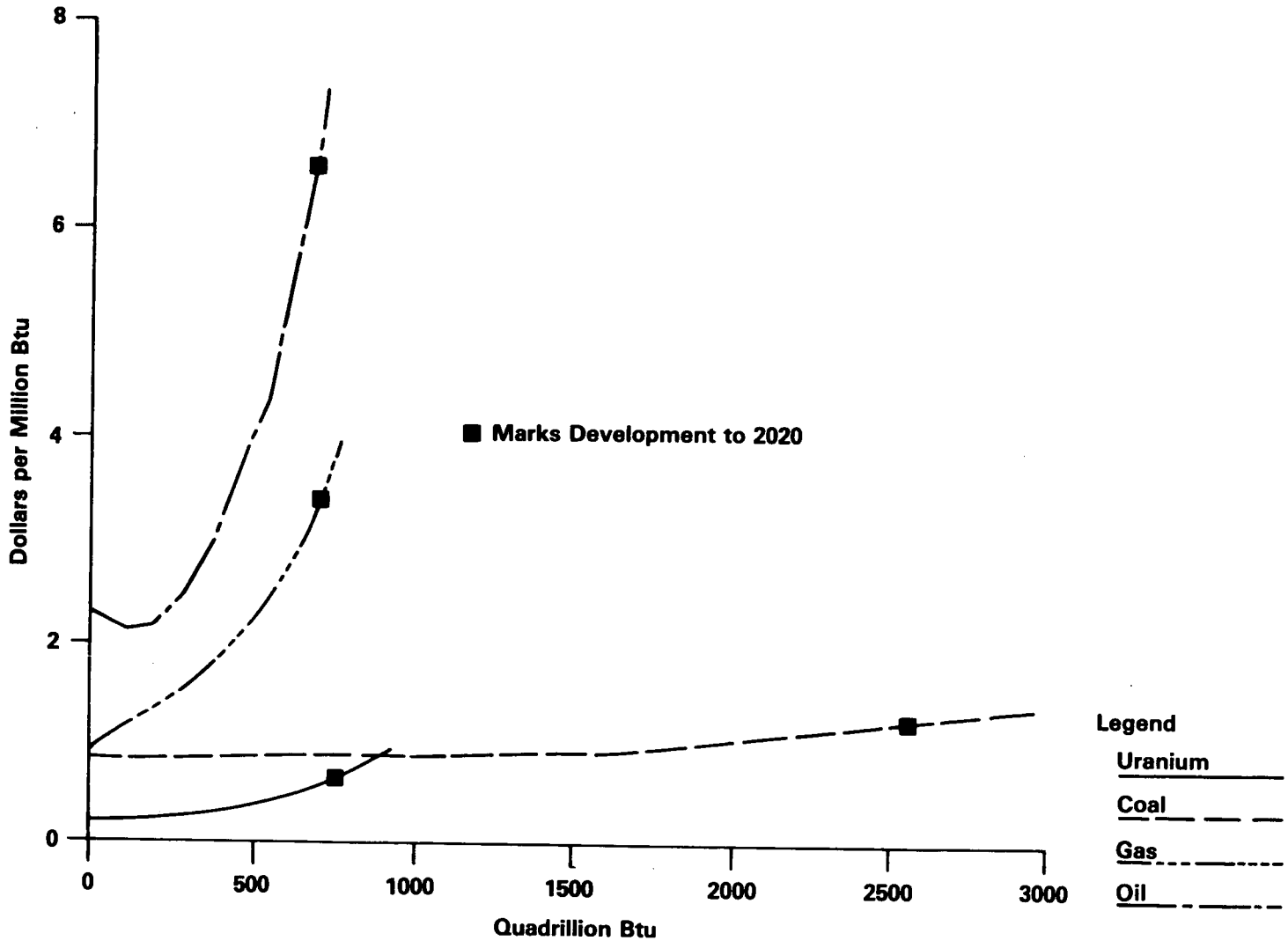

Figure 5.9 Prices of Primary Resources Increase with Cumulative Development (1979 Dollars)

The coal supply curve shown is a summation of seven coal supply curves that represent different types of coal from three geographic areas.

The analysis of crude oil supply is based on four supply curves, which are summed along their projected development paths. The price is the weighted average field cost of the production from newly committed resources. The curve dips initially when production from the giant Prudhoe Bay field on the Alaskan North Slope is initiated. The curve would increase throughout if it represented delivered costs of newly discovered crude rather than field costs. The costs of transporting North Slope crude makes its delivered cost similar to the cost of newly discovered crude from the other sources.

Natural gas supply is also based on four supply curves; three represent development in geographical areas and the fourth represents enhanced gas recovery. The curve for enhanced gas recovery represents the estimated recovery of natural gas from tight sands and Devonian shale.

The uranium supply curve shows the cost per million Btu of "yellow cake," the uranium oxide product of the ore-processing mills. The heat value assigned to this resource is the heat available to a current, light-water reactor from finished fuel made from this resource. Projected increases in the efficiency of reactor fuel utilization by 1995 are treated as increased enrichment efficiency rather than a change in the heat value of the resource used to define the supply curve.

## Coal Production and Disposition

Figure 5.10 and Table 5.16 show the projected growth of coal production. Total production increases 4.3 percent annually from 1978 to 2000 and 3.2 percent from 2000 to 2020. A large share of this growth occurs in the Western producing region, primarily because of greater resource availability. The higher cost of transportation to the major population centers partly offsets the lower mining cost in the Western region.

Western production of 34 quadrillion Btu in 2020 is equivalent to the output of about 340 surface mines, each producing 5 million tons per year. Combined Eastern and Midcontinent production of 25 quadrillion Btu is equivalent to the output of about 1100 1-million-ton per year underground mines.

The vertical bars on Figure 5.10 show the corresponding midterm projection for total coal production. The long-term projection is lower than the midterm primarily because of lower long-term electricity demand. This difference in electricity demand translates almost directly into lower coal demand.

The coal supply curves are derived primarily from midterm data, using its analytical method. The curves are extended to include resources of less certain location and quality to provide a long-term perspective. As a result of these modifications, the long-term, minemouth costs are lower than the midterm costs. To compensate, delivered costs have been increased to approximately the midterm levels.

Table 5.16 also shows coal disposition. Through 2000, coal is used primarily to satisfy industrial and utility demands. After 2000, however, coal-derived liquids and synthetic natural gas provide the major growth in coal use. Coal exports through 1995 correspond to the midterm projections, and moderate growth is assumed thereafter. The actu-

**Table 5.16 Coal Supply and Disposition, Middle Case**  
(Quadrillion Btu per Year)

	1978	2000	2010	2020
<b>Supply</b>				
Eastern.....	9.0	12.5	13.8	18.9
Midcontinent.....	2.9	12.1	14.4	18.7
<b>Western</b>				
Bituminous and Subbituminous.....	2.6	11.5	17.6	27.0
Lignite.....	0.5	2.1	3.9	7.0
<b>Total Coal Production.....</b>	<b>15.0</b>	<b>38.2</b>	<b>49.7</b>	<b>71.6</b>
<b>Disposition</b>				
<b>Direct Use<sup>a</sup></b>				
Industrial Coal.....	1.5	8.2	11.0	13.5
Industrial Met Coal <sup>b</sup> .....	1.9	2.1	2.1	2.1
Residential Coal.....	0.2	0.2	0.2	0.2
Electric Utility.....	10.2	21.4	22.6	26.2
<b>Synthetics</b>				
Liquids.....	0	2.4	9.3	23.9
Syngas.....	0	0.2	0.7	1.8
Net Coal and Coke Exports.....	0.9	3.7	3.8	3.9
Stock Change and Unaccounted Uses.....	0.2	—	—	—
<b>Total Disposition.....</b>	<b>15.0</b>	<b>38.2</b>	<b>49.7</b>	<b>71.6</b>

<sup>a</sup>A small amount of coal was used in the commercial sector in 1978.

<sup>b</sup>Metallurgical coal.

Note: Totals may not add due to independent rounding.

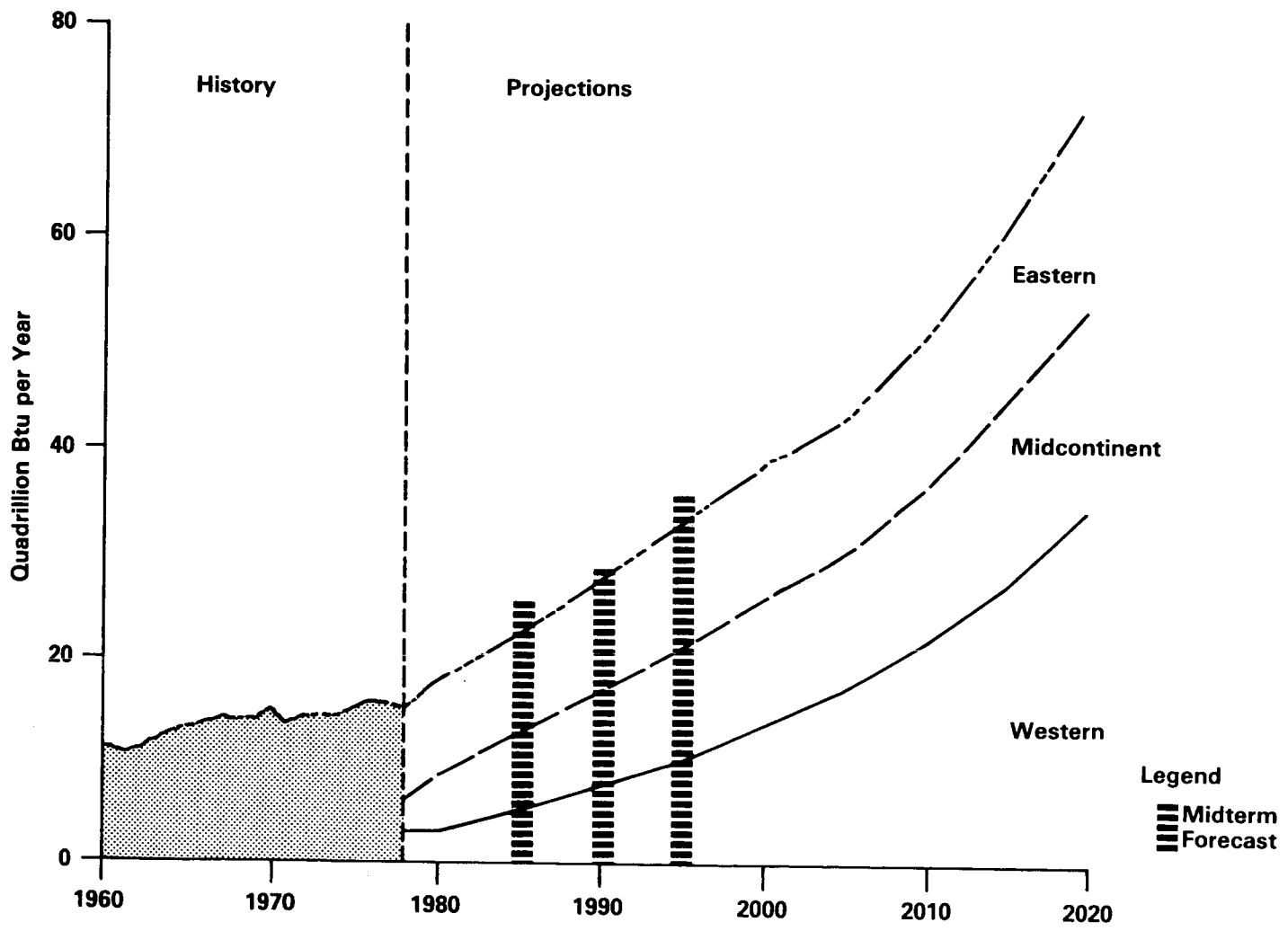

Figure 5.10 Total Coal Production by Source

al demand for coal exports could be several times higher.

Coal production in 2000 is largely insensitive to the price of imported oil. (See Table 5.17.) The shift toward coal by industry and utilities and the growth in synthetics output are fairly rapid in all three scenarios of world oil price. In the low price case from 2000 to 2020, growth in oil imports lowers the output of coal liquids below the mid-price case level. This reduces the growth of coal to 2.5 percent per year. The coal output is higher in the high price case than in the midprice case largely because of higher synthetics production.

Two-thirds of the 1.7 trillion tons of coal and lignite resources in place above 3000 feet, identified by the U.S. Geological Survey, are in the Western region, including Alaska.<sup>13</sup> The remainder is equally divided between the Midcontinent and Appalachian regions. In addition, hypothetical resources exceeding 1.7 trillion tons are surmised to exist. In comparison, the total production projected from 1975 through 2020 in the midprice case amounts to about 75 billion tons.

The identified lignite resource of 478 billion tons, largely in Montana and North Dakota, is 40 percent of identified resources in the Western region. Lignite is difficult to ship, so it will be used

primarily near the mine to produce electricity and synthetics that can be transported. The use of lignite might be limited because of the environmental impact of concentrated development in a localized area.

Development of western coal resources to the extent projected would require large investments in transportation facilities for the electricity, liquids, and synthetic natural gas produced near the mines. Also, a good portion of the western bituminous and subbituminous coal production will probably be shipped from the mining areas to avoid overly intensive development. If half of the projected production of 12 quadrillion Btu in 2000 were shipped, 12 coal slurry pipelines at 25 million tons per year each, or about 79-unit train shipments per day at 10,000 tons per shipment, would be required.

### Liquid Fuels

Figure 5.11 and Table 5.18 show the projected total supply of liquid fuels in the midprice case. The supply includes crude oil and natural gas liquids from the Lower-48 States and Alaska, crude oil from enhanced oil recovery, shale oil, crude oil and product imports, and synthetic liquids from coal and biomass. The preceding section discussed the supply of synthetic liquids; the liquid supplies from the other sources are discussed below.

<sup>13</sup> U.S. Geological Survey, Circular 1412, *op. cit.*, Table 23, p. 14.

**Table 5.17 Sensitivity of Coal Production to World Oil Price, 2000–2020**  
(Quadrillion Btu per Year)

	1978	2000			2010			2020		
		Low	Mid	High	Low	Mid	High	Low	Mid	High
<b>Supply</b>										
Eastern .....	9.0	12.3	12.5	12.4	13.2	13.8	14.0	16.5	18.9	19.6
Midcontinent .....	2.9	11.9	12.1	12.0	13.4	14.4	14.7	16.8	18.6	19.4
Western .....	3.1	13.1	13.5	13.5	19.8	21.5	22.1	28.1	34.0	35.9
Total Coal Production.....	15.0	37.3	38.2	37.9	46.4	49.7	50.8	61.4	71.6	74.8
<b>Disposition</b>										
<b>Direct Use<sup>a</sup></b>										
Industrial Coal.....	1.5	7.8	8.2	7.9	10.4	11.0	10.9	12.4	13.5	14.1
Industrial Met Coal <sup>b</sup> .....	1.9	2.1	2.1	2.1	2.1	2.1	2.1	2.1	2.1	2.1
Residential Coal.....	0.2	0.2	0.2	0.2	0.2	0.2	0.2	0.2	0.2	0.2
Electric Utility.....	10.2	21.4	21.4	21.2	22.7	22.6	22.5	26.7	26.2	26.0
Synthetics.....	0	2.2	2.6	2.8	7.3	10.1	11.2	16.1	25.8	28.6
Net Coal and Coke Exports, Stock Changes and Unaccounted Uses.....	1.1	3.7	3.7	3.7	3.8	3.8	3.8	3.9	3.9	3.9
Total Disposition.....	15.0	37.3	38.2	37.9	46.4	49.7	50.8	61.4	71.6	74.8

<sup>a</sup>A small amount of coal was used in the commercial sector in 1978.

<sup>b</sup>Metallurgical coal.

Note: Totals may not add due to independent rounding.



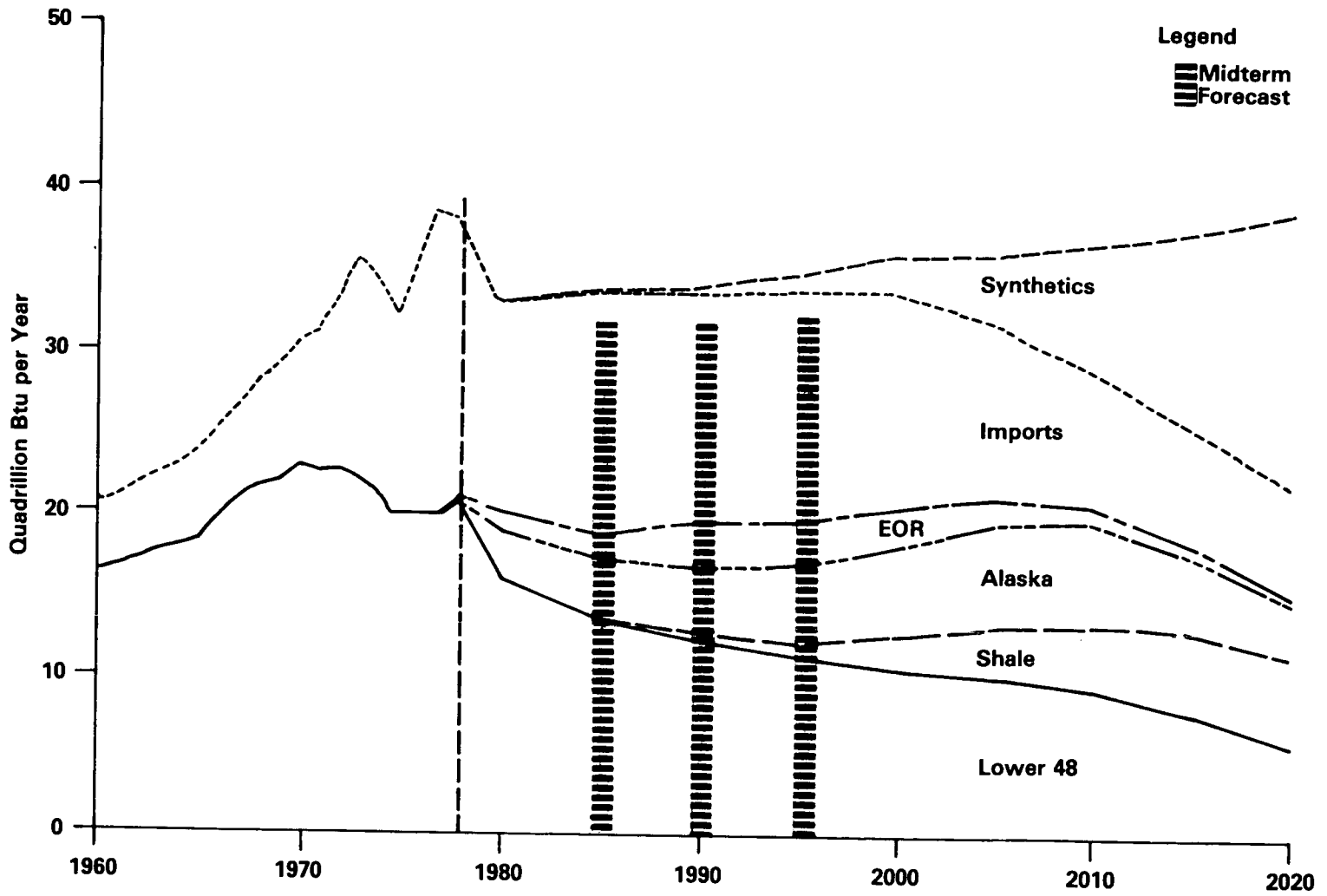

Figure 5.11 Petroleum Liquids Supply

**Table 5.18 Sources of Liquid Fuels: History and Projections, Middle Case**  
(Quadrillion Btu per Year)

	1978	2000	2010	2020
Conventional Oil and NGL				
Lower-48 States .....	17.5	10.5	9.3	5.7
Alaska .....	2.6	5.4	6.3	3.2
Enhanced Oil Recovery .....	0.6	2.5	1.0	0.5
Shale Oil .....	0	2.1	4.0	5.6
Synthetics				
Coal Liquids .....	0	1.4	5.9	15.5
Liquids from Biomass .....	0	0.8	1.6	1.2
Total Domestic Liquids Production .....	20.7	22.7	28.1	31.8
Net Oil Imports .....	17.1	13.1	8.4	6.8
Total Liquids Supply .....	37.8	35.8	36.5	38.6

NGL = Natural gas liquids.

Note: Totals may not add due to independent rounding.

The vertical bars in Figure 5.11 show the midterm liquids supply projections, which are lower than the long-term projection because of differences in the composition and level of the demand projections. The largest difference in demand for liquids is in the transportation sector.

The projected production of crude oil and natural gas liquids is shown in Figure 5.11. The long-term projections of crude oil and shale oil production have been adjusted to correspond to midterm levels. The growth and decline of Alaskan production and enhanced oil recovery combined with the steady decline of production from the contiguous United States results in a fairly slow decline rate of less than 1 percent annually from 1978 to 2010, followed by a rapid decline of over 5 percent annually to 2020.

The projection of Alaskan production is highly uncertain except for that from Cook Inlet and Prudhoe Bay. Much of the estimated, undiscovered oil is expected to be found in extremely inhospitable areas, such as the Beaufort Sea, where pack ice in the Arctic Ocean approaches the shore in winter. New production technologies may be required, and economics may limit production to exceptionally large and productive pools.

The four oil supply curves underlying these projections are largely derived from midterm data. Enhanced oil recovery, discussed below, primarily represents additional recovery from known, on-shore reservoirs of the Lower-48 States. Estimated enhanced recovery from new discoveries has been

added for the long-term analysis and contributes to production after 2000.

Enhanced oil recovery increases to 1990 and declines steadily thereafter, at about 8 percent yearly from 2000 to 2020. This rapid decrease occurs because the potential enhanced recovery from known fields is quickly exploited. Thermal recovery of heavy oil, an established technology, is a major component of enhanced oil recovery. The known heavy oil resources are expected to be largely depleted by 2000. The rate of decline is retarded only moderately by enhanced recovery from new fields and pools discovered after 1975, because these projected discoveries are small relative to the actual discoveries to date.

Shale oil production is projected to be 450,000 barrels per day in 1995, and to triple in the next 10 years to almost 1.5 million daily barrels. Thereafter, the growth is slower as the environmental limitation on shale development takes effect, and production reaches 2.6 million barrels a day in 2020. Growth in shale oil output above 600,000 barrels daily is based on the assumption that methods will be found to mitigate the impact of intensive development on air quality.

The limited, western water supply will affect shale oil production and the output of synthetic fuels from coal. The projection of high levels of Western production of these fuels is based on the assumption that water requirements will be satisfied at a cost not exceeding the estimated cost of supplying water from the upper Mississippi or Lake Superior.

From 2000 to 2020, imports decline as total demand for liquid fuels increases at the moderate rate of 0.4 percent annually, and synthetic liquids from coal and biomass more than compensate for the decline in crude oil production.

Most of the total liquids supply will be refined to produce the quantity and product mix of liquid fuels and nonfuel products demanded. Imported products, some synthetic products from coal, and alcohol fuels can be used directly or blended. Methanol from coal and woody biomass also can be converted into gasoline or other products as required. Crude oil and most of the heavy liquids produced from coal will be refined, although some crude oil and heavy coal liquids will probably be used directly as boiler fuel.

The product mix shifts toward light oil products, with light oil use increasing from about 73 percent in 1978 to 80 percent in 2000. The principal remaining fuel uses of heavy oil are for ships,

bunkers, and refinery fuel. (All refinery use of oil-derived fuels, including still gas and catalytic petroleum coke as well as liquid fuels, is classified as heavy oil in this analysis.) From 2000 to 2020, the share of light oil decreases to about 79 percent. Growth in the use of nonfuel, heavy oil products, such as asphalt and lubricating oil, increases the total demand for heavy oil products.

This shift toward light oil products after 1978, combined with the lower quality refinery inputs, results in increased intensity of refinery processing. (Each stage of processing becomes more intense as further stages of processing are added.) Much of the residual oil is reduced to petroleum coke, which can be gasified to produce the hydrogen required for hydrogenation or clean fuel gas. Raw shale oil and much of the liquids from some coal hydroliquefaction processes also will require intense processing, as will the heavy oil produced by steam soak and steam drive recovery methods.

Table 5.19 shows the estimated variation in liquids supply in response to changes in imported oil prices. In 2000, the supply of oil using conventional production methods is higher as the price of imports increases. After 2000, the supply of this oil in the low price case remains below the middle case supply and declines at about the same rate as in the middle case. In the high price case the production of conventional oil is accelerated to 2000, followed by a more rapid decline as resources are depleted.

Enhanced oil recovery in the low case is below that of the midprice case as higher cost production

is eliminated. The relation between the middle and high price cases is essentially the same as that shown by conventional oil. The higher price accelerates production in the earlier years at the expense of the later years. Cumulative production is only moderately higher by 2020 in the high price scenario.

Shale oil production is highly responsive to the price of imports, with output in the low case about half of the middle case from 2000 to 2020. Production in the high scenario exceeds that of the middle case by roughly 20 percent.

The largest changes in domestic supply are in the supply of synthetic liquids in the later years, which in 2020 in the middle case is over 60 percent greater than in the low case but is 20 percent less than in the high case.

## Natural Gas

Figure 5.12 and Table 5.20 depict the supply of natural gas and synthetic natural gas from coal, together referred to as high-Btu gas in this analysis. The synthetic natural gas is primarily methane, so it can be mixed with natural gas and distributed through the existing pipeline system. This gas can be manufactured in large, central plants producing 250 million cubic feet per day or more.

The three natural gas supply curves for conventional production in different regions are based on midterm data. The curve for enhanced gas recov-

**Table 5.19 Sensitivity of Petroleum and Synthetic Liquids Production to World Oil Price, 2000–2020**  
(Quadrillion Btu per Year)

	1978	2000			2010			2020		
		Low	Mid	High	Low	Mid	High	Low	Mid	High
<b>Conventional Oil</b>										
Lower-48 States .....	17.5	9.7	10.5	11.0	8.6	9.3	9.5	5.5	5.7	4.7
Alaska .....	2.6	4.8	5.4	5.6	5.1	6.3	6.2	2.8	3.2	2.8
Enhanced Oil Recovery .....	0.6	1.6	2.5	2.6	0.6	1.0	1.1	0.3	0.5	0.3
Shale Oil .....	0	1.0	2.1	2.7	2.0	4.0	4.9	2.5	5.6	6.7
<b>Synthetics</b>										
Coal Liquids .....	0	1.2	1.4	1.5	4.3	5.9	6.8	9.8	15.5	17.5
Alcohol (Biomass) .....	0	0.3	0.8	0.8	0.4	1.6	1.9	0.4	1.2	2.5
Total Domestic Production .....	20.7	18.5	22.7	24.2	20.9	28.1	30.3	21.3	31.8	34.6
Net Oil Imports .....	17.1	23.3	13.1	8.4	22.6	8.4	3.4	24.2	6.8	2.0
Total Liquids Supply .....	37.8	41.8	35.8	32.6	43.5	36.5	33.7	45.6	38.6	36.6

Note: Totals may not add due to independent rounding.

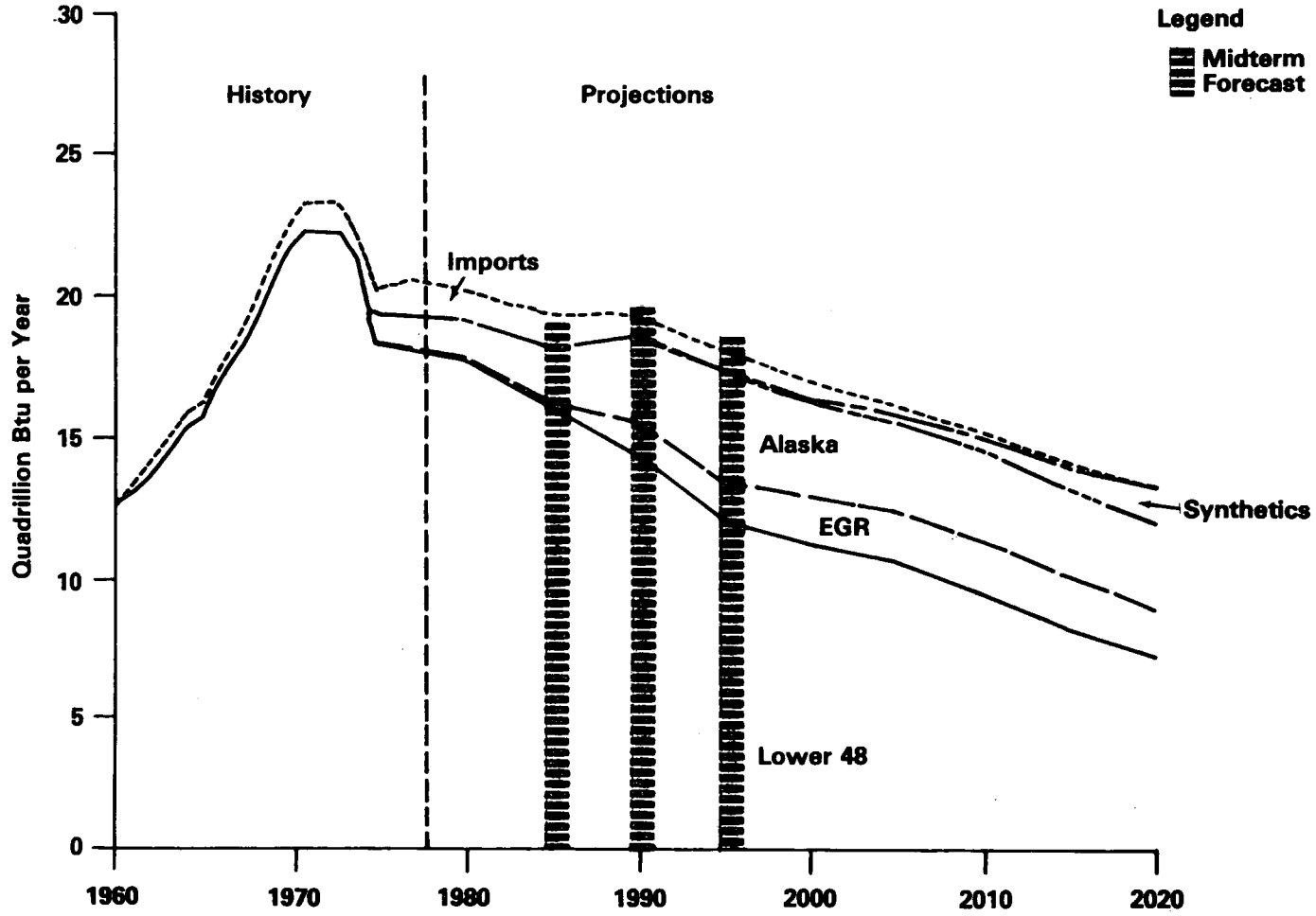

Figure 5.12 Natural Gas Supply by Source

**Table 5.20 Sources of Gaseous Fuels: History and Projections, Middle Case (Quadrillion Btu per Year)**

	1978	2000	2010	2020
Conventional Natural Gas				
Lower-48 States.....	18.4	11.3	9.5	7.3
Alaska.....	0.2	1.6	1.9	1.8
Enhanced Gas Recovery.....	0.9	3.4	3.2	3.1
Synthetic Gas, High-Btu.....	0	0.1	0.5	1.3
Total Domestic Gas Production	19.5	16.5	15.1	13.4
Net Gas Imports.....	0.9	0.7	0.2	0.1
Total Gas Supply.....	20.4	17.2	15.3	13.5

Note: Totals may not add due to independent rounding.

ery includes recovery from advanced technologies in addition to the midterm data for production using current technologies. Production of natural gas in 1995 has been adjusted to correspond to the midterm projections.

Total supply of high-Btu gas is relatively constant from 1978 to 1990, declines moderately to 2000, and then decreases 1.2 percent annually from 2000 to 2020. The decline of Lower-48 production is partially offset during the first 22 years by the growth of enhanced gas recovery. Production from Alaska, after the completion of the pipeline from the North Slope by 1990, also supports domestic output. After 2000, the growth of high-Btu gas from coal is the primary compensating factor.

After the Alaskan gas pipeline is completed, production from Alaska is projected to continue to increase until 2010 and then to decline. The projection of natural gas production from Alaska, in excess of that from Cook Inlet and Prudhoe Bay, is subject to the same uncertainties as that of Alaskan oil production. In addition, the higher cost of its transportation to the contiguous United States may limit production even further.

Enhanced recovery of natural gas trapped in tight sands and Devonian shale in major basins is represented in this analysis. Total, potential recovery that is assumed available from these resources by 2020 includes all of that which is estimated to be recoverable using current technologies and half of that using advanced technologies.

The remaining amount estimated to be recoverable as a result of the development of still more advanced technologies (gas recovered from coal seams and methane produced from geopressured aquifers) is not included. This conservative ap-

proach may result in underestimation of natural gas production by enhanced recovery methods after 2000.

Projected production to 2000, however, probably would be increased only moderately by including the omitted potential. The projected 6.2 percent growth rate of enhanced recovery production from 1978 to 2000 is quite high and requires a major drilling effort. Enhanced gas recovery is discussed in more detail below.

Natural gas imports in 1985 through 2000 include only the liquefied natural gas imports that are under contract, as explained in the midterm chapter.

The long-term projection of natural gas supply from domestic sources is lower than that of midterm because of the lower long-term projections of gas demand. Gas imports decrease to a minimal level of 0.1 quadrillion Btu in 2020.

Total supply of high-Btu gas is fairly insensitive to the price of imported oil, despite the price of imported natural gas being based on the crude oil price in this analysis. (See Table 5.21.) In part, this insensitivity is because imports are a relatively small part of total consumption and therefore the price of delivered gas is based primarily on domestic production costs.

In the low world oil price case, gas imports are higher than in the middle and high price cases. Because total gas demand remains relatively constant over the projection period, domestic production of gas is reduced slightly as imports increase.

## Nuclear Fuel

The nuclear fuel cycle for current and potential light-water reactor technology is shown in Figure 5.13. The "front end" of the cycle is comprised of the various chemical and physical processes needed to extract uranium ore from the ground, enrich its fissile (energy-producing) fraction, and fabricate the individual fuel elements for use in the reactor. The "back end" of the fuel cycle consists of steps required to manage the radioactive waste products.

Currently, discharged (or "spent") nuclear fuel is being temporarily stored, generally at the individual reactor sites, pending development of acceptable procedures for ultimate disposition of the radioactive wastes in the spent fuel.

The problem of ultimate disposal of nuclear waste must be resolved for nuclear power to

**Table 5.21 Sensitivity of Natural Gas Production to World Oil Price, 2000–2020**  
(Quadrillion Btu per Year)

	1978	2000			2010			2020		
		Low	Mid	High	Low	Mid	High	Low	Mid	High
Conventional Natural Gas										
Lower-48 States .....	18.4	10.9	11.3	11.2	9.6	9.5	9.7	7.3	7.3	7.5
Alaska .....	0.2	1.6	1.6	1.6	1.7	1.9	1.9	1.5	1.8	1.8
Enhanced Gas Recovery .....	0.9	3.2	3.4	3.3	3.0	3.2	3.2	2.8	3.1	3.1
Synthetic Gas, High-Btu .....	0	0.1	0.1	0.1	0.4	0.5	0.5	0.9	1.2	1.1
Total Domestic Production .....	19.5	15.7	16.5	16.3	14.7	15.1	15.2	12.5	13.3	13.5
Net Gas Imports .....	0.9	1.7	0.7	0.6	0.8	0.2	0.2	1.1	0.1	*
Total Gas Supply .....	20.4	17.4	17.2	16.9	15.4	15.3	15.4	13.6	13.5	13.6

\*Less than 0.05 quadrillion Btu.

Note: Totals may not add due to rounding.

continue even its present contribution to domestic energy supply. The long-term projections of nuclear power assume that this issue is resolved, that the light-water reactor “once-through” cycle is utilized, and that reprocessing occurs only for the breeder reactor technology.

The projections suggest two interesting results concerning the front end of the fuel cycle. First, a transition from the current “gaseous diffusion” enrichment technology, a very electricity-intensive process, to the more advanced and less energy-intensive “centrifuge” technology occurs by 1990, in response to rising electricity prices. This result supports the economic desirability of the Carter administration’s plans to introduce the first large centrifuge enrichment plant in 1989. (Uranium enrichment technologies more advanced than the centrifuge process are not considered in these projections.)

The second result is that known reserves plus estimated potential resources from conventional uranium deposits are largely committed by 2020. This resource depletion causes uranium price increases, as the costs of finding scarcer uranium and mining lower grade deposits increase.

Although there is a huge backstop of nonconventional uranium resources (Chattanooga shales, for example), the projected price of uranium by 2020 is not quite as high as the cost of unconventional production.

In the long-term projection of fabricated nuclear fuel supply, all the cost components of nuclear fuel are assumed to remain constant in real terms over the entire projection period, except for uranium oxide and enrichment services. (See Table

5.22.) Total nuclear fuel cost increases at about 1.7 percent annually after 2000 to 12.54 mills per kilowatt-hour in 2020, or \$1.14 per million Btu of heat input calculated at 11,000 Btu per kilowatt-hour.

Estimates of the domestic uranium resource base, from which this uranium supply is drawn, are shown below. These estimates, made on January 1, 1979, by the U.S. Department of Energy’s Grand Junction Office (GJO), reflect the “forward cost” categorization, in that costs shown (in 1979 dollars per pound of U<sub>3</sub>O<sub>8</sub>) are those yet to be expended and do not include sunk costs, taxes, profit, or amortization of existing capital stock. Thus, the forward cost does not represent the price at which uranium will be marketed. The original GJO estimates have been converted to quadrillion Btu of heat input by assuming an 85-percent recovery factor for the uranium mill and the fuel efficiency of the improved, once-through, light-water reactor.

#### Uranium Resource Estimates in Quadrillion Btu

(Cumulative Totals)

Forward Cost Category	Known Reserves	Potential Resources		
		Probable	Possible	Speculative
15	90	219	284	307
30	215	528	738	832
50	287	756	1121	1292

Note: Each estimate includes all lower cost and higher certainty estimates.

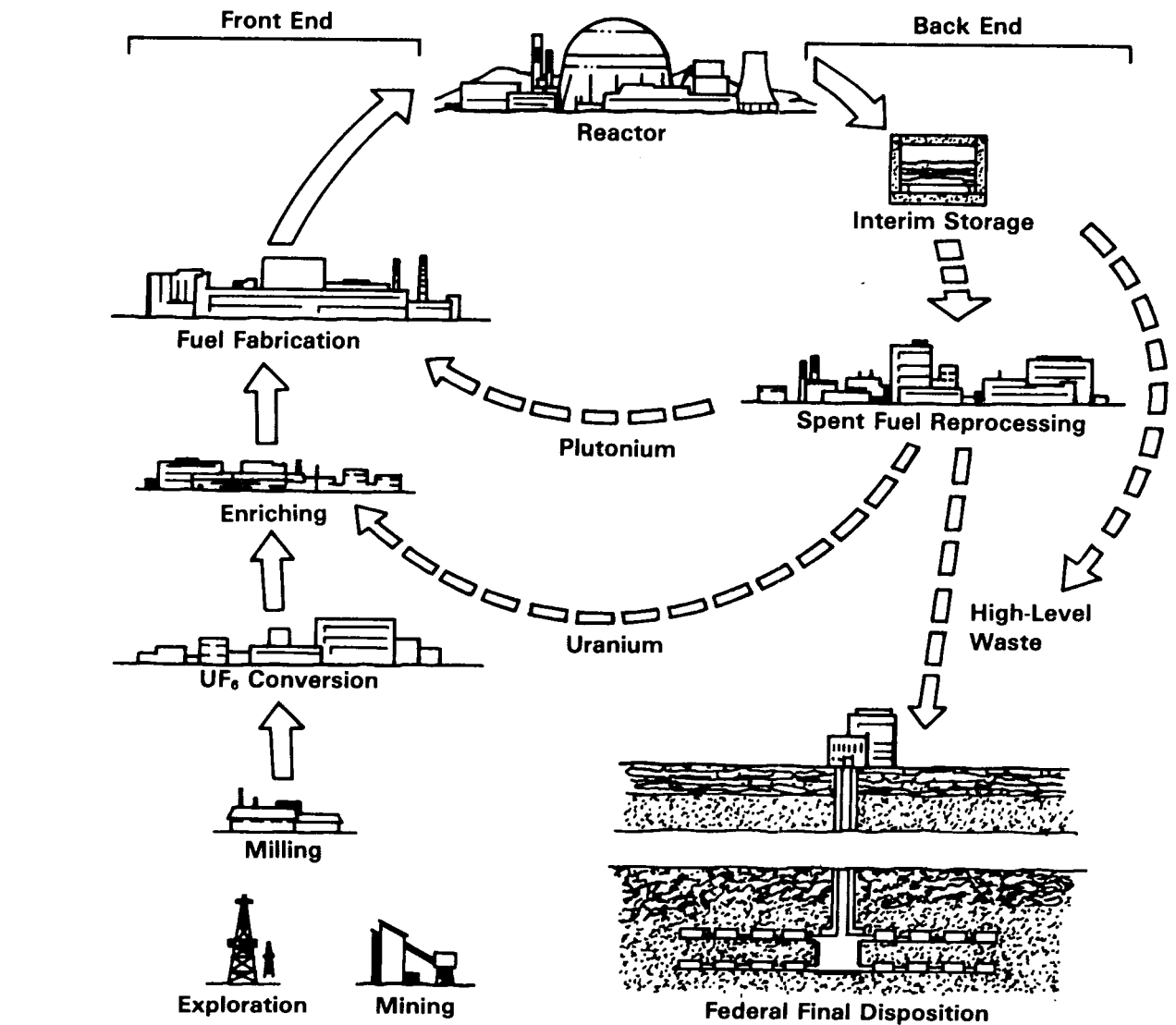

➡ Fuel cycle as it operates currently.

◻➡ Sectors affected by Carter Administration decision to indefinitely defer commercial reprocessing of spent nuclear fuel. Official policy in this area has not yet been formulated, but under alternative waste disposal schemes, spent fuel may be stored for possible reprocessing in the future, or placed in repositories for final disposition.

**Figure 5.13 Nuclear Fuel Cycle**

**Table 5.22 Average Nuclear Fuel Processing Cost Assumptions by Component (1979 Dollars)**

Processing Category	Unit Price		Contribution to Nuclear Generating Cost (mills per kilowatt-hour)	
	2000	2020	2000	2020
	Uranium Oxide (dollars per pound) .....	47.00	86.50	4.57
Conversion to Uranium Hexafluoride (dollars per pound) .....	2.20	2.20	0.14	0.14
Enrichment (dollars per SWU) .....	115.50	109.60	2.75	2.61
Fabrication (dollars per kilogram) .....	109.00	109.00	0.53	0.53
Spent Fuel Storage (dollars per kilogram per year) .....	6.50	6.50	0.22	0.22
Spent Fuel Transportation (dollars per kilogram) .....	17.40	17.40	0.05	0.05
Spent Fuel Disposal Fee (dollars per kilogram) .....	217.80	217.80	0.62	0.62
Total .....	—	—	8.88	12.54

SWU = Separative work units.

The GJO classifies its resource estimates according to a scale of increasing uncertainty. The most certain are reserves since the estimates are based on direct engineering data, such as cores from drill holes. The most uncertain are speculative resources, which are estimated to occur in promising, geological formations or provinces not previously productive. Probable and possible resources refer to intermediate degrees of uncertainty. (See the Glossary for definitions of these terms.)

The quantities of uranium oxide resources in the above table are cumulative. The amount available at a higher price includes the amounts available at lower prices. The 215 quadrillion Btu of reserves at \$30 per pound includes the 90 at \$15 per pound. Similarly, the amount available at a higher degree of uncertainty includes the amounts at lower uncertainty. The 528 quadrillion Btu of probable resources at \$30 per pound includes the reserves available at that price.

By the end of 2020, the nuclear power program is projected to have consumed about 500 quadrillion Btu of uranium, which is about equal to the reserves plus probable potential at less than \$30 per pound forward cost. More significantly, the lifetime (30-year) commitments for light-water reactors projected through 2020 are about 900 quadrillion Btu, which approaches the total resource base at the highest cost category. Thus, the expansion of the domestic nuclear power program, as projected in this report, depends on the existence and discovery of most of the estimated potential uranium resources.

## Emerging Supply Sources

Figure 5.14 illustrates the projected contribution of emerging sources of supply to the domestic production of liquid fuels and high-Btu gases. Production from these sources increases from 1.5 quadrillion Btu in 1978 to 10 quadrillion Btu in 2000 and to almost 27 quadrillion Btu in 2020. The average annual growth rate is over 9 percent to 2000 and almost 5 percent from 2000 to 2020. This projected growth is more than sufficient to compensate for declining production of petroleum liquids and gases from conventional methods.

The emerging technologies for oil and gas production, other than synthetics from coal and biomass that are described in the conversion section, are summarized below, followed by a discussion of domestic geothermal and biomass resources.

### Enhanced Oil Recovery

Enhanced oil recovery (EOR) refers to methods used to recover more crude oil from a petroleum reservoir than can be recovered using conventional primary or secondary recovery techniques. EOR technologies include thermal methods, gas flood, and chemical means.

Thermal processes apply heat to decrease the viscosity and increase the mobility of oil in the reservoir. Major thermal processes are steam injection and fire flood (insitu combustion). Steam injection is the most advanced and the most widely used EOR process. It constitutes 50 percent or



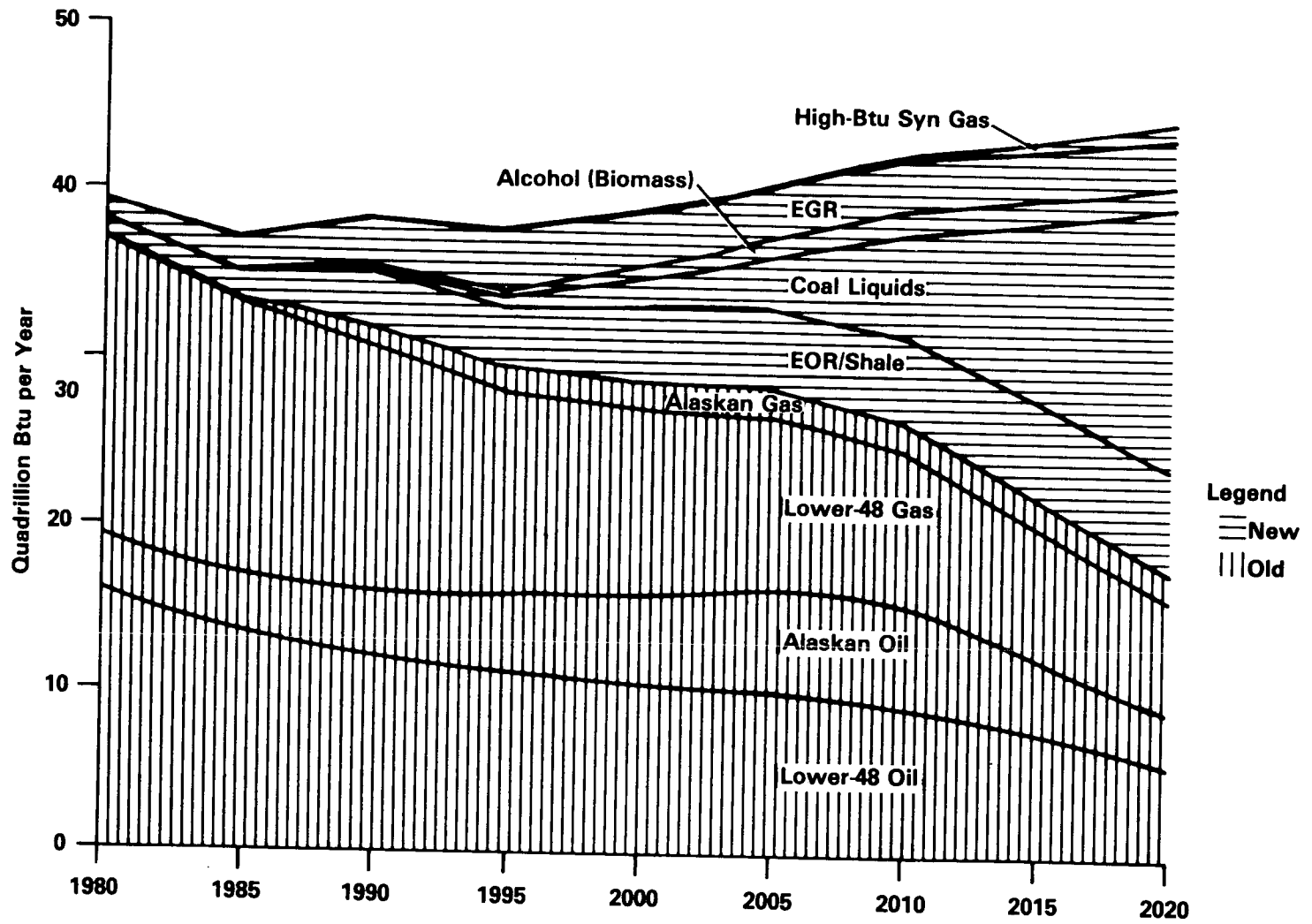

Figure 5.14 Comparison of Oil and Gas Production from Old and New Technologies

more of total EOR production and is concentrated in California where it has been successfully used since the mid-1960's.

The in situ combustion process injects hot air into a reservoir and ignites the oil it contains. Although some oil is lost by burning, the hot gases formed by the combustion process move ahead to reduce the viscosity of the oil and to push it toward producing wells. The method is theoretically applicable to a relatively wide range of crude oils, although it was originally conceived to apply to very viscous crude oil not susceptible to water flooding.

Gas flood refers to miscible flood processes, which inject fluids to dissolve the oil and form a single oillike liquid that is able to flow through the reservoir more easily than the original crude. A variety of such processes has been developed using different fluids that can mix with oil, including alcohols, carbon dioxide, and various natural gas liquids. Because of the high cost of hydrocarbons, the leading candidate is carbon dioxide, which is in limited commercial use.

Chemical processes involve injecting materials such as detergents, caustics, and polymers to modify the chemical and physical interaction of oil with its surroundings and increase the mobility of the oil. This process is the most complex and expensive of the EOR methods and has a large degree of uncertainty, but it has widespread applicability.

The major technical barrier to using EOR technologies is a lack of knowledge concerning reservoir characteristics and the inability to predict their performance in any given reservoir.

Several environmental impacts stem from enhanced oil recovery that may impose limitations on its use. Air emission control standards are delaying or shutting down thermal EOR facilities in California. Water quality standards are also a major concern. Chemical flooding through old wells has the potential of introducing chemicals into fresh water aquifers with potentially deleterious results. Concerns also exist over biocides, which are needed to protect polymers used in flooding operations.

## Oil Shale

Oil shale is a sedimentary rock that contains an organic polymer called kerogen, which decomposes when heated to produce shale oil. There are significant deposits throughout the world, although world production remains small.

The Department of Energy has estimated potentially recoverable oil from shale in the Western United States to be more than 360 billion barrels. About 80 percent of this amount is located on federally owned land in Colorado, Utah, and Wyoming.

Shale oil is extracted by a retorting process that heats the shale to 900–1,000°F and collects the hydrocarbon fraction that is emitted. Recovery methods can be roughly grouped into three categories: surface retorting, in situ, and modified in situ.

Surface retorting involves conventional open pit or room and pillar mining. The oil shale is then transported to the surface where it is retorted in large vessels to produce raw shale oil.

In situ operations involve hydraulic or explosive fracturing, followed by in place retorting and fluid drive through hot liquid injection, hot gas injection, or direct combustion of part of the hydrocarbons in the shale.

Modified in situ operations conventionally mine a fraction of the shale first. The remaining shale is then "rubblized" or caved into the created void, which should create the permeability and porosity necessary for effective in situ retorting.

Although the surface retorting technology is presently more advanced than in situ retorting, in situ methods are expected to be more important in the long term as they can be applied to lower yield shales, and therefore can be expected to recover a higher percentage of the total shale oil resource and to reduce the environmental impact of shale oil production.

Raw shale oil is of a much poorer quality than most crude oil, and it must be upgraded through a hydrotreating process to be competitive. Although not all existing refineries will be able to refine this upgraded product, a large number should be able to refine it to jet and diesel fuel.

Current air quality standards could place an upper limit on the ultimate size of the shale oil industry, which may be located in Colorado. Under current air quality regulations, the Federal class II standard for sulfur dioxide has been set at an annual average of 20 micrograms per cubic meter. This limit implies an estimated limit of shale oil production of about 500,000 to 600,000 barrels per day. In this analysis, technologies to meet this standard at higher levels of production are assumed to become available by 2000.

U.S. oil shale yields about three-quarters of a barrel of oil per ton of rock. Consequently, a commercial-scale plant produces an enormous amount of spent shale. Satisfactory disposal of this

material has been a concern to the Environmental Protection Agency and environmentalists, but it is assumed that this problem can be managed at a reasonable cost.

### Enhanced Gas

There are four unconventional geologic sources of natural gas: gas-bearing shale formations of the Eastern United States; low-permeability (tight) sandstone reservoirs of the Rocky Mountain region; free methane present in coalbeds; and high-pressure, methane-saturated aquifers of the Gulf Coast region (geopressured aquifers). Present estimates of the recoverable gas present in each resource vary considerably, as shown below.

Resource	Potentially Recoverable (trillion cubic feet)
Eastern Gas Shales	10-520
Tight Gas Sands	50-320
Methane from Coalbeds	16-500
Geopressured Aquifers	150-2000

The wide range in each estimate implies that accurate geological and engineering data are not available.

Eastern or Devonian shale is found in the Appalachian Basin. Historically, Devonian shales in eastern Kentucky have been a primary exploration and development target for natural gas. However, with the rise in energy prices, more exploration has begun in West Virginia and Ohio. As of December 1974, there were approximately 9500 Devonian shale wells in Kentucky, West Virginia, and Ohio. Considerable areas of poorer quality and deeper lying brown-black shale sequences have not yet been explored.

Small hydraulic fracturing has been successful in eastern Kentucky. Other technologies currently being tested for their effectiveness in recovering gas from Devonian shales include: massive hydraulic fracturing, cryogenic or gas fracturing, intensive explosive fracturing, and deviated well drilling.

For more than a quarter century, large quantities of natural gas have been known to exist in tight (low permeability), lenticular (discontinuous) sandstone formations where the gas flow is too low to support economic recovery under conventional technology. The basins containing these formations stretch westward from the Cotton Valley Trend in Louisiana, through Texas, to the Uinta

Basin of Utah, and north through the Northern Great Plains geological province, crossing the border into Canada.

Massive hydraulic fracturing has become a standard practice for extracting gas in low permeability, but otherwise favorable, geologic formations. It involves high-pressure injection of fluids into the well bore to fracture reservoir formation rock, and the use of proppants (usually sand) to keep the fractures open to the flow of gas.

Since the inception of underground coal mining, the release of methane from coalbeds has posed a safety hazard. Until recently, the major goal has been to dispose of rather than to capture the methane. However, if recovered, this currently vented methane could provide an important addition to local industry and household supply.

The recovery of methane would occur first in high-emission mines located in the Appalachian region. In addition, potential sources of methane in the deep, thin, and unminable western coal seams are located in Colorado, New Mexico, Utah, and Wyoming.

In the fourth source, geopressured aquifers, methane gas is trapped in large water-bearing reservoirs, characterized by significantly higher temperatures and pressures than their depth suggests. Aquifers are found beneath the Gulf of Mexico and the coastal regions of Texas and Louisiana. If it is possible to produce the formation water, extract the methane, and dispose of the spent water in an economically and environmentally sound way, these reservoirs could contribute to the Nation's gas supply. These aquifers are also a potential geothermal source.

The basic technology for recovering methane from the geopressured aquifers consists of drilling wells capable of producing vast quantities of gas-bearing water, installing facilities to capture the methane that comes out of the solution at atmospheric conditions, and disposing of the water once the gas is released. With improved extraction facilities, it is believed that up to 85 percent of the gas can be recovered from the produced water. However, only about 2 to 5 percent of the reservoir's water can be produced before exhausting the reservoir's drive mechanism.

Two environmental problems are associated with gas produced from geopressured aquifers. Production of this gas removes large volumes of brine, which increases tectonic activity along growth faults. Also, the disposal of corrosive brine under high pressure constitutes an engineering challenge.

## Geothermal Resources

Geothermal resources are defined as identified and undiscovered forms of heat stored in the earth, that are recoverable using current technology, regardless of cost. These resources can be tapped by drilling, and the heat can be brought to the surface in a fluid for electricity generation or for direct thermal use. The resource base includes vast amounts of energy dispersed throughout large volumes of rock and fluids. Three major categories of resources are hydrothermal convection; geopressured; and hot, dry rock. For the long-term analysis, only the hydrothermal resource has been considered. Geopressured and hot, dry rock resources are difficult to evaluate, given the uncertainties of cost and availability of the necessary technologies. For this reason, the future use of geothermal energy may be underestimated.

Hydrothermal resources consist of water and steam trapped in fractured rocks or sediments. These resources are the best understood of all geothermal resources and are currently used for electric production and direct thermal applications. The quantity of energy in this resource category, estimated by the U.S. Geological Survey, is 370 to 440 quadrillion Btu.<sup>14</sup> The maximum amount estimated for energy use is 18 quadrillion Btu. These quantities are distributed over the western half of the United States, with the greatest amount located in California.

Geopressured resources are mentioned as geopressured aquifers under enhanced gas recovery. In addition to the dissolved methane, these resources contain thermal energy that might be used. Estimates for the amount of energy eventually available from this resource range from one-third to three times the quantity available from hydrothermal sources. These quantities include the dissolved methane, which is roughly 70 percent of this resource.<sup>15</sup>

Hot, dry rock resources consist of hot rocks at accessible depths that are relatively unfractured and contain little or no water. To extract usable power, these resources require fracturing to intro-

duce and circulate a heat transfer fluid. The estimates of energy that could be available from this resource are approximately four times that which is available from hydrothermal resources.<sup>16</sup> These resources are found primarily in the Western States, with some unknown amount of low-grade heat at considerable depths in the Eastern United States.

## Biomass Resources

The sources of biomass, or biological matter, are conveniently categorized as plant matter, animal waste, human waste, and refuse. Plant matter, constituting 80 to 90 percent of current resources, can be obtained from wood, land crops, and marine sources. Of these, wood comprises the largest amount of material. Currently, the wood forms most commonly used are mill residue by the lumber industry and black liquor and other wastes by the paper industry. Abundant amounts of logging residue left in the forest are available for energy use, but collection costs are a major impediment. Removal of this residue also would accelerate the rate of soil depletion.

The concept of a cultivated forest, or silviculture, has received increasing attention and may be a major source of biomass in the future. Experimentation on tree varieties and techniques for producing optimal yields is taking place. Also, yields on existing commercial forestlands can be improved. Either of these approaches could increase yields to two to three times current levels.

A second, general source of plant matter is agricultural residues such as straw, cornstalks, and cane stalks. Care must be taken in using these residues for energy purposes so that the soil is not deprived of needed organic mulch. It is uncertain how much excess plant matter can be used without depleting the soil. Grains and other high sugar content produce can be processed to produce ethanol for motor fuel. Some high-yield, high-energy content crops, such as sugar cane, sugarbeets, and sweet sorghum, may be grown especially for fuel.<sup>16</sup> A limitation on the use of cultivated crops for energy, whether it be forests or agricultural crops, is that it competes with food and fiber crops for farming resources such as land, water, and fertilizer.

A possible third source of plant material is marine growth. Two principle plants that have

<sup>14</sup> U.S. Geological Survey, Circular No. 790, "Assessment of Geothermal Resources of the United States—1970," Reston, VA, 1979.

<sup>15</sup> Interagency Geothermal Coordinating Council, *Geothermal Energy Research, Development and Demonstration Program*, U.S. Department of Energy (Washington, D.C., March 1979) p. 12.

<sup>16</sup> *Ibid.*

received consideration are ocean kelp and water hyacinths. The kelp would be farmed on large artificial grids floated at sea. The hyacinth grows in shallow inland fresh water bodies. Both produce abundant yields but costs are currently prohibitive.

A form of biomass that currently is being used is animal manure, which is collected from feedlots and processed to produce methane. A high-quality fertilizer is a byproduct of this process. Use of this resource, the amount of which is roughly comparable to the quantity available from crop residues, is expected to increase rapidly.

Other limited but currently viable sources of biomass are municipal solid waste and municipal sewage. Municipal solid waste can be burned directly or further processed to liquid or gaseous fuels. Some separation of noncombustibles is desirable. Sewage treatment plants can utilize collected solids to produce methane. These uses have the advantage of disposing of what otherwise is a costly nuisance.

A wide range of assessments of the total quality of biomass available for energy use might be expected, because of the variety of sources and uses. Nevertheless, the estimate of total long-term U.S. resources reported in three studies were surprisingly close, at 8<sup>7</sup>, 10.5<sup>7</sup>, and 12.8 quadrillion Btu.<sup>17,18,19</sup> Woody crops and residues comprise the major portion of the resource. Other crops grown specifically for energy use are expected to play a minor role because of competing demands for food and fiber crops.

## CONCLUDING REMARKS

Although the long-term projections of end-use fuel consumption are similar to current patterns, the projected sources of energy supply are vastly

<sup>17</sup> U.S. Energy Research and Development Administration, *Solar Program Assessment: Environmental Factors, Fuels from Biomass* (Washington, D.C., March 1977) pp. 12-13.

<sup>18</sup> Schooley, F.A. et al., *Mission Analysis of the Federal Fuels from Biomass Program* (Menlo Park, CA: Stanford Research Institute International, December 1979), p. 20.

<sup>19</sup> J. R. Benemann, "Biomass Energy Economics," *The Energy Journal*, Vol. 1 No. 1 (January 1980) p. 111.

different. Coal and biomass will produce synthetic liquids; nuclear and coal will compete for the utility market; new and improved technologies will make more efficient use of energy; and renewables will supply a sizeable portion of total energy requirements. This transformation in energy supply can result in less dependence on oil imports. However, this shift in supply will require major capital expenditures and a high rate of growth in coal production.

Table 5.23 shows the market penetration of new technologies for the low, middle, and high world oil price scenarios. New oil technologies satisfy the majority of the liquids demand in the forecast period. A major finding in this analysis is that, under the assumption of relatively high world oil prices (middle and high oil price scenarios), a long-term energy supply equilibrium is approached in 2020 with synthetic liquids becoming the "backstop technology."

New, more energy-efficient, coal-fired technologies make a sizeable penetration in the utility market, as do central renewables. These technologies, along with nuclear-fueled generation plants (light-water reactor, fast-breeder reactor, and fusion) not only replace oil and gas plants but are the supply sources for the increasing demand for utility-generated electricity. Other emerging technologies such as industrial cogeneration reduce energy consumption through increased efficiencies.

This long-term forecast outlines a possible energy future for the United States and identifies many important energy issues. In these projections, the ability to decrease U.S. dependence on imported energy is found to depend primarily on the rate at which shale oil and coal liquefaction plants can be built in order to satisfy the demand for hydrocarbon liquids. Despite the higher development rates assumed after 1995, the Nation does not become energy self-sufficient by 2020. A basic conclusion is that the date at which an energy market free of shortages might be achieved depends on how soon and how rigorously the development of alternative energy sources can be pursued. Intensive effort should be undertaken in several areas including:

- development of synthetic conversion plants
- support of nuclear power development
- increased research into renewable sources
- effective conservation programs.

**Table 5.23 Emerging Technology Summary: Projection Series Low, Middle, High  
(Quadrillion Btu per Year)**

	1978	2000			2010			2020		
		Low	Mid	High	Low	Mid	High	Low	Mid	High
<b>Oil</b>										
Enhanced Recovery.....	0.60	1.56	2.52	2.57	0.56	1.03	1.07	0.25	0.46	0.29
Shale.....	0	1.01	2.09	2.66	1.98	4.00	4.92	2.52	5.61	6.70
Synthetic Crude (Coal).....	0	1.00	1.00	1.05	3.50	3.50	3.68	8.00	8.00	8.40
Methanol (Coal).....	0	0.15	0.30	0.32	0.59	1.50	1.58	0.81	5.00	5.25
Boiler Fuel (Coal).....	0	0.03	0.11	0.18	0.22	0.93	1.51	0.99	2.48	3.87
Alcohol (Biomass).....	0	0.31	0.80	0.84	0.38	1.59	1.89	0.40	1.24	2.49
<b>Gas</b>										
Enhanced Recovery.....	0.90	3.18	3.39	3.34	2.97	3.18	3.19	2.81	3.09	3.14
High-Btu (Coal).....	0	0.10	0.13	0.14	0.34	0.49	0.45	0.83	1.22	1.09
Low-Btu (Industrial).....	NA	0.32	0.29	0.27	0.43	0.39	0.38	0.49	0.44	0.44
<b>Utility Electricity</b>										
Combined Cycle.....	0	0.48	0.49	0.48	0.89	0.89	0.89	1.38	1.34	1.33
Atmospheric Fluidized Bed (AFB).....	0	1.13	1.15	1.14	1.91	1.90	1.90	2.69	2.60	2.57
Magneto hydrodynamic (MHD).....	0	0.01	0.01	0.01	0.20	0.20	0.20	1.12	1.09	1.08
Fuel Cells, Coal Gasifier.....	0	0.08	0.08	0.08	0.31	0.31	0.31	0.77	0.75	0.75
Fuel Cells, Oil.....	0	0.07	0.02	0.01	0.08	0.02	0.01	0.09	0.02	0.01
Biomass.....	*	0.08	0.08	0.08	0.13	0.09	0.09	0.18	0.10	0.09
Solar.....	0	0.03	0.03	0.03	0.10	0.10	0.10	0.28	0.30	0.30
Ocean Thermal Energy Conversion (OTEC).....	0	0.01	0.01	0.01	0.05	0.05	0.05	0.21	0.23	0.24
Wind.....	0	0.03	0.03	0.03	0.03	0.03	0.03	0.03	0.03	0.03
Geothermal.....	0.01	0.53	0.53	0.56	0.80	0.80	0.84	1.05	1.05	1.10
Fast Breeder Reactor.....	0	0	0	0	0.02	0.03	0.03	0.07	0.08	0.08
Fusion.....	0	0	0	0	0	0	0	0.01	0.01	0.01
<b>Decentralized Renewables</b>										
<b>Solar</b>										
Residential.....	*	0.37	0.39	0.39	0.83	0.87	0.88	1.47	1.54	1.56
Commercial.....	*	0.09	0.10	0.11	0.16	0.20	0.21	0.25	0.32	0.34
Industrial.....	*	*	0	0	*	*	*	0.01	*	*
<b>Geothermal</b>										
Residential.....	*	0.06	0.06	0.06	0.30	0.30	0.32	0.63	0.63	0.66
Commercial.....	*	0.09	0.08	0.07	0.19	0.17	0.17	0.32	0.29	0.29
Industrial.....	*	0.14	0.14	0.15	0.27	0.27	0.28	0.44	0.44	0.46
Biomass (Industrial).....	*1.30	3.98	3.98	4.18	4.53	4.46	4.23	5.18	5.18	3.91
Photovoltaic (Residential).....	0	0.10	0.11	0.11	0.36	0.38	0.38	0.88	0.93	0.95
<b>End-Use Technologies</b>										
<b>Heat Pump</b>										
Residential <sup>b</sup> .....	NA	3.10	2.99	2.93	3.31	3.26	3.24	3.05	3.03	3.04
Industrial.....	0.01	0.06	0.05	0.04	0.13	0.08	0.08	0.22	0.12	0.15
AFB (Industrial Indirect Heat).....	0	0.40	0.34	0.31	0.60	0.37	0.38	0.69	0.36	0.42
<b>Cogeneration<sup>c</sup></b>										
Oil.....	NA	0.26	0.02	*	0.40	0.02	*	0.54	0.03	0.01
Low-Btu Gas (LBG).....	0	1.08	1.37	1.67	1.43	2.68	2.68	1.64	3.47	3.76
Atmospheric Fluidized Bed (AFB).....	0	0.83	0.84	0.84	1.34	1.34	1.34	2.06	2.06	2.06

\*Estimated.

<sup>b</sup>Oil and gas, heating and cooling.

<sup>c</sup>Electricity and steam production.

\*Less than 0.005 quadrillion Btu

## Glossary

- API:** American Petroleum Institute.
- ASTM:** American Society for Testing and Materials.
- C.I.F:** Cost, insurance, and freight.
- CPE:** Centrally Planned Economies.
- EEC:** European Economic Community.
- EIA:** Energy Information Administration.
- EPA:** Environmental Protection Agency.
- ERA:** Economic Regulatory Administration.
- ESECA:** Energy Supply and Environmental Coordination Act of 1974.
- FERC:** Federal Energy Regulatory Commission.
- FOB:** Free on board.
- GDP:** Gross Domestic Product.
- GNP:** Gross National Product.
- IEA:** International Energy Agency.
- LDC:** Lesser Developed Countries.
- LEAP:** Long-Term Energy Analysis Program.
- LMFBR:** Liquid Metal (sodium) Fast Breeder Reactor.
- LWR:** Light-Water Reactor.
- MEFS:** Midterm Energy Forecasting System.
- MEMM:** Midterm Energy Market Model.
- MMBD:** Million Barrels per Day.
- NASAP:** Nonproliferation Alternative Systems Assessment Program.
- NEA:** National Energy Act of 1978.
- NGPA:** Natural Gas Policy Act of 1978.
- PIFUA:** Powerplant and Industrial Fuel Use Act of 1978.
- SEDS:** State Energy Data Systems.
- STIFS:** Short-Term Integrated Forecasting System.
- USGS:** United States Geological Survey.
- Alaskan North Slope:** The Alaskan coastal plain between the Brooks Range and the Beaufort Sea.
- Alternative fuel cost ceiling:** The limit on the surcharges that can be passed on to low-priority natural gas users. This surcharge is limited by alternative fuel costs according to the Natural Gas Policy Act of 1978.
- API gravity:** An arbitrary scale expressing the gravity or density of liquid petroleum. The scale is expressed in degrees API (American Petroleum Institute) and is related to specific gravity at standard conditions by the following formula:  $\text{Deg. API} = (141.5/\text{sp gr}) - 131.5$ .
- Associated-dissolved natural gas:** Gas occurring in crude oil reservoirs either as free gas (associated) or as gas in solution with crude oil (dissolved).
- Autogeneration:** The generation of electricity by industry, using conventional technologies, which substitutes for electricity purchased from a utility.
- Back end of the fuel cycle:** Those activities involved in the processing or management of nuclear radioactive waste material.
- Backstop:** Once a resource is exhausted, either physically or economically, the market price for a commodity will be determined by the next best substitute, called the "backstop." This substitute represents a competing process that may eventually displace the resource through market interaction.
- Balance of payments area:** The 50 States, District of Columbia, and all U.S. territories and possessions.
- Baseload:** A subdivision of the total demand profile for electricity. This load category refers to those plants which operate continuously, except for maintenance requirements, to satisfy demand.
- Black liquor:** An organic, liquid byproduct of the pulping process burned in boilers by the paper industry.
- Biomass technology:** The conversion of organic matter to alcohol, and the fermentation or decomposition of organic byproduct materials to

- produce methane or other fuels. Raw materials for these processes include forest residues, crop residues, animal manures, and urban solid waste.
- British thermal unit (Btu):** The amount of heat required to raise the temperature of 1 pound of water 1°F.
- Capacity factor:** The ratio of actual output generated in a specific time period to maximum potential in the same period.
- Capitalized outlays:** Expenditures that, for accounting purposes, are not charged wholly in the time period incurred but allocated over future time periods.
- Ceiling price:** The maximum price permitted under regulations.
- Chemical flooding process:** An enhanced oil recovery technique using injection of water with added chemicals into a petroleum reservoir. In this assessment, two chemical types are considered: surfactants and polymers.
- Coal slurry:** A pulverized coal-liquid mixture transported by pipeline.
- Cogeneration:** The generation of both steam and electric energy in the same facility.
- Combined cycle plant:** A two-stage electricity generating plant with the first stage composed of combustion turbines and the second stage, a waste heat-steam generator system that operates with the exhaust heat of the first stage.
- Coke (coal):** Bituminous coal from which constituents have been driven off by heat so the fixed carbon and the ash are fused. Coke is used primarily in blast furnaces for smelting ores, especially iron ore.
- Concentrating collectors:** Devices for solar radiation collection that redirect sunlight received on an area to a much smaller area for heat transfer. They generally require tracking mechanisms and are more expensive than flat-plate collectors, but produce higher temperatures.
- Crude oil:** A mixture of hydrocarbons that exists in the liquid phase in natural underground reservoirs and remains liquid at atmospheric pressure after passing through surface separating facilities. Statistically, crude oil reported at refineries, in pipelines, at pipeline terminals, and on leases may include lease condensates.
- Crude Oil Entitlements Program:** A program designed to allocate the benefit of access to lower priced oil proportionally to all refiners, through a system of monetary transfers, as extended by the Energy Policy and Conservation Act, December 22, 1975.
- Crude runs:** Quantity of crude oil and petroleum liquids processed through a refinery's crude oil distillation units.
- Curtailement:** The difference between demand and consumption when there is a short supply.
- Decline rate:** The annual percentage decrease in production.
- Derated:** An order by the Nuclear Regulatory Commission to operate a nuclear plant at less than full capacity.
- Developmental well:** A well drilled within the presently known or proved productive area of a reservoir, as indicated by reasonable interpretation of data, with the objective of obtaining oil or gas from that reservoir.
- Devonian shale:** Geologic formations underlying an area of approximately 250,000 square miles in the middle and eastern sections of the United States. These organically rich shales are one target of enhanced gas recovery.
- Direct heat:** Processes in which the heat and products of combustion are applied directly to the raw material.
- Distillate Fuel oil:** A light fuel oil distilled off during the refining process. Included are products known as No. 1 and No. 2 heating oils, diesel fuels, and No. 4 fuel oil. These products are used primarily for space heating, on- and off-highway diesel engine fuel (including railroad engine fuel), and electric power generation.
- Distrigas:** A private corporation that operates a project to import liquefied natural gas into the Eastern United States from Algeria.
- Dry hole:** A well that does not yield oil or gas in commercially marketable quantities.
- Economic rent:** The difference between the marginal cost and the price of a depletable resource. Rent provides the incentive for the resource owner to produce today rather than postponing investment and production in anticipation of higher prices.



**Elasticity:** The rate of change in the quantity demanded of a good divided by the rate of change in an economic variable, such as price or income. An elasticity can be used to estimate the impact of a change in an economic variable on the quantity demanded. For example, a price elasticity of -0.2 indicates a 10-percent increase in prices will result in a 2-percent decrease in demand.

- *Price elasticity.* The economic variable is price.
- *Income elasticity.* The economic variable is income.
- *Short-term elasticity.* An elasticity, usually a price elasticity, reflecting the change in demand for a good that occurs over a time span so short as not to allow changes in capital stock.
- *Long-term elasticity.* An elasticity, usually a price elasticity, reflecting the changes in demand for a good occurring over a time span long enough to allow for adjustments in capital stocks. Usually, long-term elasticities are larger in absolute value than short-term elasticities.
- *Feedback elasticity.* A long-term elasticity, in this report an oil-price elasticity, that has been estimated by a process reflecting the impacts on economic growth.
- *System elasticity.* A price elasticity derived from an alternative equilibrium energy model that allows all energy prices to change, with all other exogenous input variables, such as income, remaining unchanged.

**El Paso I:** A project to import liquefied natural gas into the Eastern United States from Algeria.

**End-use demand:** Energy consumption measured at the final consuming sectors—residential, commercial, industrial, transportation—consisting of marketed fuels.

**Energy balance:** An account of the quantities of energy supplied and consumed during a specified time period.

**Energy converters:** Industries that convert fuels from one form into another more usable form, such as refineries and electric utilities.

**Energy losses:** The difference between primary energy supply and final end-use demand. Losses result from conversion processes (such as electricity generation).

**Enhanced gas recovery (EGR):** Increased recovery of natural gas from a reservoir through the external application of physical or chemical processes. An example of an EGR process is hydraulic fracturing.

**Enhanced oil recovery (EOR):** The recovery of oil from a petroleum reservoir resulting from application of a recovery process beyond secondary oil recovery. An example of an EOR process is steam injection. Also, see chemical flooding process, miscible flooding process, and thermal recovery process.

**Enrichment:** A process whereby the percentage of a given uranium isotope ( $^{235}\text{U}$ ) present in a material is artificially increased to a higher percentage of that isotope naturally found in the material.

**Entitlement:** Subsidies of imported crude oil and imported petroleum products, paid for by refiners with access to a larger than average quantity of domestic crude oil that is subject to price controls. The entitlements program is administered by the Economic Regulatory Administration (ERA). This administration issues entitlements to importers of foreign crude oil and assigns them a value. A refiner obtains the right to process certain categories of low-cost domestic crude oil by purchasing entitlements for the amount of such crude he wishes to process.

**Exploratory well:** A well drilled to find oil or gas in an unproved area; to find a new reservoir in a field known to contain productive oil or gas reservoirs; or to extend the limit of a known oil or gas reservoir.

**Extraction loss:** The loss of energy occurring in processing natural gas to remove some of its constituents. These constituents include the natural gas plant liquids such as ethane, propane, butane, natural gasoline, and undesirable gases such as hydrogen sulfide.

**Feedstock:** A raw material in production. For example, petroleum distillates used for producing petrochemicals are referred to as petrochemical feedstocks.

**Fissile material:** Capable of being fissioned (split into several parts) by neutrons, resulting in the release of energy. The only naturally occurring fissile material is  $^{235}\text{U}$ , an isotope of uranium with an atomic mass of 235.

- Fleet average efficiency:** The average efficiency, measured in miles per gallon, of the entire vehicle stock.
- Flue gas:** Gaseous combustion products.
- Fluidized-bed combustion boiler:** A furnace design in which the fuel is buoyed up by air. It offers advantages in the removal of sulfur during combustion.
- Forced outage:** The unexpected shutdown of electrical generating facilities because of failures in the equipment.
- Fossil fuel:** Any naturally occurring fuel such as coal, oil, and natural gas, derived from the remains of ancient plants and animals. These sometimes are called conventional fuels or conventional energy sources (as compared with nuclear power, solar, and wind energy) because they provide the bulk of today's energy for most of the world's industrial economies.
- Front end of the fuel cycle:** Those activities involving the preparation of nuclear fuel, encompassing the range from exploration for natural uranium to the fabrication of nuclear fuel assemblies.
- Fuel cell:** A device that produces electrical energy directly from the controlled electrochemical oxidation of the fuel. It does not contain an intermediate heat cycle, as do most other electrical generation techniques.
- Fuel efficiency degradation relationship:** A quantitative statement defining the achieved, on-road fuel economy as compared to the EPA-rated fuel economy, based on standardized tests for a specific model car or model year.
- Fusion:** The combining of atomic nuclei of very light elements by high-speed collision to form new and heavier elements, the result being the release of energy.
- Gas flaring:** The burning of excess or undeliverable gases. Natural gas produced in conjunction with crude oil is sometimes flared at the wellhead.
- Gasohol:** A mixture of gasoline and alcohol. Ratios may vary but typically it is 90 percent gasoline and 10 percent alcohol.
- Gasoline tilt:** A regulatory program that is part of the price controls placed on petroleum produced. The program allows for the allocation of increased refiner costs to be placed on gasoline.
- Geologic province:** Any large area or region considered as a whole. All parts are characterized by similar features or by a history differing significantly from that of adjacent areas.
- Geothermal energy:** Energy from the internal heat of the earth, which may be residual heat, friction heat, or a result of radioactive decay. The heat is found in rocks and fluids at various depths and can be extracted by drilling and/or pumping.
- Gigawatts electric (GWe):** One million kilowatts of electricity.
- Grid:** The network of electric power transmission and distribution lines of a utility. Where applicable, grid refers to interconnected networks of two or more utilities.
- Gross withdrawals of natural gas:** Total amount of natural gas extracted from both oil and natural gas wells.
- Heat Pump:** A mechanically driven device that uses a refrigeration cycle to raise a low-grade heat source to a higher temperature. (The heat pump may also provide air cooling, dehumidifying, circulating, and air cleaning.)
- Heavy crude oil:** Crude oil containing a weighted average gravity of 20.0 degrees API or less, corrected to 60°F.
- Heavy fuel oil:** A liquid product produced in refining crude oil that is used as fuel, rather than as asphalt for road building or tar for roofing. (See Residual fuel oil.)
- Heliostats:** A steering mechanism attached to a solar reflecting mirror. This mechanism is part of a solar-thermal power system that drives the mirror to track the sun and simultaneously reflects the light to a central location.
- High-Btu gas:** High-Btu gas is predominantly methane and has a heat content greater than 800 Btu per cubic foot. High-Btu gas can be produced from coal through chemical reactions (coal gasification). Natural gas, a high-Btu gas, has a heat content in the range of 900–1100 Btu per cubic foot.
- Hook-up moratorium:** A temporary halt in providing new homes with natural gas service. This moratorium occurred in the mid-1970's and was regional, not nationwide. It came about because the utilities were unsure of their ability to obtain enough natural gas for new customers.

- Hubbert Factor:** A method used to estimate the growth of ultimate recovery over time from known oil and gas fields. Estimation method is based on average growth curves for those fields, derived from historical changes in estimates of ultimate oil and gas recovery with time, since those fields were discovered.
- Hydropower:** Electricity generation using water flow to drive a turbine.
- Implicit GNP deflator:** A measure of the change in U.S. price levels, which is the ratio of the current value of goods and services to the base-year value for the same goods and services.
- Income elasticity:** (See Elasticity.)
- Indicated reserves:** (See Reserves.)
- Indirect heat:** Processes in which the material being heated is separated from the combustion process by a heat transmitting barrier or by an intermediate transfer material such as steam.
- In-situ combustion:** Combustion of unmined material at its natural site. The basic procedure involves drilling boreholes into a seam of the earth's strata. Ignition of the seam follows in the presence of either air or oxygen.
- Intermediate load:** A subdivision of the total demand profile for electricity. It represents load characteristics that affect dispatching decisions. This load category defines the demand range between the continual baseload and daily and seasonal peakloads. It represents approximately 15 to 25 percent of total electricity demand.
- International Energy Evaluation System (IEES):** An international energy forecasting system the Energy Information Administration uses to provide forecasts of energy prices, supplies, demands, and conversion activities.
- Interstate gas:** Natural gas that entered interstate commerce and was hence subject to Federal controls under the Natural Gas Act.
- Intrastate gas:** Natural gas that is both produced and consumed within the same State. (Before the Natural Gas Policy Act became law, intrastate gas was not regulated by the Federal Government.)
- Lease condensate:** Natural gas liquids recovered from wells (including those associated with crude oil reservoirs) in lease separators or field facilities. Lease condensates consist primarily of pentanes and heavier hydrocarbons and are comingled with crude oil in shipment to refining facilities. In this analysis, production of crude oil is defined to include lease condensate with crude oil for refining.
- Linear programming:** A mathematical technique for solving constrained optimization problems in which all functional relations are linear.
- Light truck:** The truck class size of gross vehicle weight of 10,000 pounds or less. This category includes vans and light utility vehicles used for personal transportation.
- Light-water reactor (LWR):** A nuclear reactor in which water is the primary coolant-moderator, with slightly enriched uranium fuel.
- Lignite:** A brownish-black coal in which the alteration of vegetal materials has proceeded further than peat, but not as far as subbituminous coal. The heat value of lignite is below 8300 Btu per pound.
- Liquefied natural gas (LNG):** Natural gas that has been cooled to about -160°C for storage or shipment as a liquid in high pressure cryogenic containers.
- Liquefied petroleum gas (LPG):** A gas containing certain specific hydrocarbons that are gaseous under normal atmospheric conditions, but can be liquefied under moderate pressure at normal temperatures. The principal examples of LPG are propane and butane.
- Load factor:** The ratio of average electricity demand to the highest, or "peak," demand.
- Long-term Energy Analysis Program (LEAP):** The long-term energy model developed by EIA: a multisector, multifuel, multiyear energy model of U.S. energy markets.
- Low-Btu gas:** A fuel gas with a heat content in the range of 100–250 Btu per cubic foot. A gaseous fuel produced from coal or other material.
- Low-priority user:** FERC establishes priorities for different classes of users of natural gas. When natural gas shortages occur, the low-priority users are curtailed. Gas curtailment to low-priority users can be expected during real demand periods such as those caused by severe winters. The Natural Gas Policy Act of 1978 requires that FERC pass on some of the costs of expensive natural gas, first, to low-priority users.
- Lump-sum tax:** A tax paid in a single installment. An example of this is the gas guzzler tax mandated by the Energy Tax Act of 1978 (PL

95-618), which places a tax on the purchase of new passenger cars with fuel economies below specified levels.

**Magnetohydrodynamics (MHD):** An advanced power generation system that operates by forcing a hot ionized gas through a magnetic field to induce an electric voltage. This system is analogous to a typical generator that passes a conductor through a magnetic field. Direct current is produced and therefore must be passed through an inverter. The exhaust gas is used in a conventional steam-turbine cycle.

**Market-clearing price:** The estimated price of a commodity at which its demand equals its supply.

**Measured reserves:** (See Reserves.)

**Medium-Btu gas:** Gas with a heat content of 300-750 Btu per cubic foot. A gaseous fuel produced from coal or biomass that can be used in boilers or direct heat applications.

**Metallurgical coal:** Coal used to produce metallurgical coke, a primary input in steel production.

**Metallurgical coke:** A porous, carbonaceous material produced from coal and used in the steel industry.

**Microlevel:** Refers to analysis or data collection that is collected and analyzed at the individual, household, or firm level.

**Microsimulation:** A modeling technique in which the activities in individuals, households, and firms are directly represented in the model.

**Minemouth:** The location where a mined fuel, such as coal, is extracted from the earth. The term can refer to the location of a conversion facility, such as a minemouth gasification plant, or to a point of measurement, such as the minemouth costs of uranium.

**Miscible:** Capable of mixing at any ratio, without separation into components.

**Miscible flooding process:** An enhanced oil recovery technique using injection into a petroleum reservoir, of a material that is miscible with the oil in the reservoir. In this report, carbon dioxide (CO<sub>2</sub>) is the only such material considered.

**Monte Carlo technique:** A probabilistic approximation method, using random sampling techniques, to determine the characteristics of a system given the presence of uncertainty.

**National Energy Act of 1978:** A package of five bills affecting the U.S. energy markets. The five acts are:

- The National Energy Conservation Policy Act
- The Powerplant and Industrial Fuel Use Act
- The Public Utilities Regulatory Policy Act
- The Natural Gas Policy Act
- The Energy Tax Act

**Natural gas liquids:** Those portions of reservoir gas that are liquefied at the surface in lease separators, field facilities, or gas-processing plants—natural gas plant liquids (NGPL). Includes ethanes, propanes, butanes, pentanes, and natural gasoline.

**Natural gas production, dry:** The natural gas remaining after the natural gas liquids have been removed. It represents the amount of domestic natural gas production that is available to be marketed and consumed.

**Nominal prices:** Those prices actually observed in the marketplace at any point in time. Nominal prices are sometimes referred to as market prices.

**Nonassociated natural gas:** Natural gas not in contact with crude oil in the reservoir.

**Nuclear fuel cycle:** The term for all stages of nuclear fuel processing from uranium exploration through disposition of radioactive waste disposal.

**Nuclear fuel reprocessing:** The chemical separation of spent (used) nuclear fuel into salvageable fuel material and radioactive waste.

**Ocean thermal energy conversion (OTEC):** A solar electric technology, where a central station powerplant makes use of the temperature differences between surface and deep ocean waters to produce electricity.

**Oil shale:** A range of shale materials containing organic matter (kerogen) that can be converted into crude shale oil, gas, and carbonaceous residue by destructive distillation.

**Organization for Economic Cooperation and Development (OECD):** A 24-member body composed of the United States, Canada, Japan, the Western European countries, Australia, and New Zealand. The organization's purpose is to promote mutual economic development, and contribute to the development of the world economy.

**Organization of Petroleum Exporting Countries (OPEC):** A cartel of oil exporting nations consisting of Venezuela, Ecuador, Indonesia, Algeria, Libya, Nigeria, Gabon, Iran, Kuwait, Saudi Arabia, Iraq, the United Arab Emirates, Qatar, and the Neutral Zone.

**Passive solar heating:** Systems that use heat flows, evaporation, or other natural processes to collect and transfer heat. (South-facing windows and greenhouses are two examples.)

**Peakload:** A subdivision of the total demand profile for electricity. This load category requires intermittent operation of plants designed to respond to the highest levels of demand.

**Petrochemical:** Any chemical derived from petroleum or natural gas, such as polyethylene.

**Phase-change system:** A system for storing heat that utilizes the heat of fusion, or heat absorbed or released as a material melts or solidifies. Because such changes occur at a constant temperature and involve a large amount of heat, the thermal storage capacity per unit of volume is very high.

**Photovoltaics:** Devices that directly generate electrical current when exposed to sunlight. They are constructed of semiconductor materials that react to light or heat energy by allowing electrons to be accelerated across a junction.

**Present value:** A measure of today's worth of a future income stream, discounted at a given interest rate.

**Pressurized-water reactor:** A light-water reactor design in which water in the nuclear fuel core is pressurized to prevent boiling. Heat is transferred from the core by circulating the pressurized water to a steam generator, in order to fuel a turbine for electricity generation.

**Price elasticity:** (See Elasticity.)

**Price path:** A specified annual sequence of prices from the current year.

**Price tier:** Classes of crude oil production established for purposes of Government price controls.

**Primary oil production:** Crude oil production from a reservoir where the flow of oil into the well is due to natural pressure in the reservoir.

**Product mix (refined):** Combination of products resulting from the refinery process.

**Proved reserves:** (See Reserves.)

**Pyrolysis:** A process for conversion of coal and other materials that applies heat in the absence of oxygen. The products are coke, liquids, and gases.

**Rankine cycle system:** The theoretical cycle that describes the conversion of heat energy to work and uses vapor as the working medium. It is the cycle employed in the typical steam-turbine generating plant and may be considered an external combustion engine cycle.

**Real disposable income:** The figure, which is expressed in dollars of constant value within the National Income Accounting framework, is obtained by subtracting corporate earnings not paid out as dividends, depreciation, or taxes from gross national product. Transfer payments and Government interest payments are then added. This figure is intended to represent the income that the public has available for making purchases.

**Real prices:** Nominal prices adjusted for the effects of inflation on the purchasing power of the dollar. These prices are always referenced by a particular year, such as real 1979 dollars, and sometimes are referred to as constant prices. In this report, the implied price deflator for GNP is used to measure the impact of inflation.

**Real oil price:** The nominal price of oil, C.I.F. U.S. East Coast, deflated by the U.S. GDP index of prices.

**Refiner's acquisition cost:** The cost of crude oil to the refiner, including transportation and fees. It is the average of domestic and imported crude oil costs which, in turn, a refiner can pass on to its customers under petroleum price control regulations, in force until October 1981.

**Refinery utilization rate:** The percent of total crude oil throughput capacity at which a refinery is operated.

**Renewable resources:** Sources of energy not subject to exhaustion, such as wood, solar, hydro, and wind.

**Replacement cost price:** The cost of energy material to replace the last unit used. When applied to natural gas, this means the marginal wellhead price plus the fully allocated transportation and distribution costs.

**Reserve extensions:** (See Reserves.)

**Reserve margins:** A measure of excess electric generating capacity for meeting peak demand. The ratio of total capacity minus peak demand to peak demand.

**Reserve revisions:** (See Reserves.)

**Reserves:** Identified deposits of minerals known to be recoverable using current technology and under present economic conditions. Categories of reserves are:

- *Extensions.* Reserves credited to a reservoir because of enlargement of its proved area, generally due to additional drilling activity.
- *Indicated reserves.* Reserves that include additional recoveries in known reservoirs (in excess of the measured reserves), which engineering knowledge and judgment indicate will be economically available by application of fluid injection, whether or not such a program is currently installed (API, 1974).
- *Inferred reserves.* Reserves based on broad geological research for which quantitative measurements are not available. Such reserves are estimated to be recoverable in future years as a result of extensions, revisions, and additional drilling in known fields.
- *Measured reserves (or proved reserves).* Identified sources from which an energy commodity can be economically extracted with existing technology, and whose location, quality, and quantity are known on the basis of geologic evidence supported by engineering evidence.
- *Revisions.* Changes in earlier proved reserve estimates, either upward or downward, resulting from new information, not necessarily from additional drilling.

**Residual fuel oil:** Topped crude oil obtained in refinery operations, includes ASTM grades No. 5 and No. 6, heavy diesel, Navy Special, and Bunker C oils used for generation of heat and/or power.

**Resources:** Concentration of economically valuable materials occurring in or on the Earth's crust in forms that economic extraction is currently or potentially possible. Categories of resources are:

- *Identified resources.* Specific bodies of materials whose location, quality, and quantity are known from geologic evidence supported by exploratory probes into the deposits. This category of resources is frequently subdivided based on the estimated cost of recovery or

the certainty of supporting evidence of existence of the deposits. (See Reserves.)

- *Undiscovered resources:* Unspecified bodies of materials surmised to exist on the basis of broad geologic knowledge and theory, but which have not been identified by drilling. (Through exploration resources, they are moved into reserves.) In classifying uranium resources, this category is further subdivided into the following categories:

- *Probable resources.* Uranium estimated to occur in known productive areas, which are either extensions of known deposits or in undiscovered deposits within known geologic trends or areas of mineralization.
- *Possible resources.* Uranium estimated to occur in undiscovered or partly defined deposits in formations or geologic settings that are productive elsewhere within the same geologic province or subprovince.
- *Speculative resources.* Uranium estimated to occur in undiscovered or partly defined deposits in formations or geologic settings not previously productive.

**Royalty:** Payment to the owner of mineral rights by the producer, in compensation for the extraction of the mineral.

**Saturation:** A market is assumed to be saturated if demand is growing at or below the rate of GNP growth.

**Scenario:** Specification of assumptions pertaining to states of nature (e.g., size of resource base), economics (e.g., gross national product), and Government policy (e.g., price controls), used in making projections.

**Scrubber:** Equipment used to remove sulfur from flue gas emissions.

**Secondary oil production:** A method of recovery in which part of the energy employed to move hydrocarbons through the reservoir into the production wells is obtained by injecting liquids or gases into the reservoir.

**Separative work unit (SWU):** The measure of the physical effort expended in an enrichment plant to separate a quantity of uranium (of a given fissile concentration) into two components—one having a higher and one having a lower fissile concentration.

**Service demand:** The demand for end-use services, such as vehicle-miles of travel or levels of space heat, provided by equipment that uses energy.

**Shale oil:** A liquid similar to conventional crude oil but obtained by processing an organic mineral (kerogen) in oil shale.

**Shift reaction:** A chemical reaction through which the ratio of hydrogen to carbon monoxide, as obtained from a coal (or wood) gasification process, is adjusted to the proportion desired for production of a specific product, such as methane.

**Small-refiner bias:** A provision in the Entitlements Program that allocates additional entitlements to small refiners.

**Softness (in markets):** Refers to an economic market situation characterized by excess supply.

**Solar flatplate collectors:** Equipment used to capture solar energy. A collector is usually a black absorber surface in an insulated frame, and is attached to pipes through which a fluid circulates to carry the heat to a storage tank.

**Space heat:** Heat generated to warm an enclosed space, such as the interior of a house.

**Spot market:** Sales available for immediate delivery, not generally recurring under fixed-term contracts.

**Spot prices:** The price of a commodity (such as coal) applying to immediate delivery, as distinguished from future delivery under a long-term contract.

**Standard deviation:** A measure of dispersion in a frequency distribution. It equals the square root of the mean of the squared deviations from the arithmetic mean of the distribution.

**Substitute fuel cap:** The limit to the price of natural gas that can be charged to low-priority users and still have a surcharge. The alternate fuel price defines the substitute fuel cap. (See alternative fuel cost ceiling.)

**Subbituminous coal:** Coal with a heat content of 7500 to 10,000 Btu per pound.

**Syncrude:** The liquid hydrocarbons produced from organic deposits, such as shale, tar sands, and coal.

**Syngas:** A High-Btu gas resulting from the manufacture, conversion, or reforming of petroleum hydrocarbons or coal. Syngas may be easily substituted for, or interchanged with, pipeline-quality natural gas. (See High-Btu gas.)

**Synthetic Natural Gas (SNG):** Gas manufactured from coal, petroleum, or biomass. SNG from naphtha is the most common today. (See High-Btu gas.)

**Tar sands:** Consolidated or unconsolidated rocks with interstices containing bitumen that ranges from very viscous to solid. In its natural state, tar sands cannot be recovered through primary methods of petroleum production.

**Tertiary recovery:** Enhanced recovery of crude oil from a reservoir, through the external application of heat or chemical processes that supplement naturally occurring or simple-fluid injection processes. (See Enhanced oil recovery.)

**Thermal integrity:** The ability of the shell of a building to prevent passage of heat (either unwanted gain or loss) by conduction through the walls, infiltration through cracks, or radiation through windows.

**Thermal recovery process:** An enhanced oil recovery technique using injection of steam into a petroleum reservoir (steam drive), or propagation of a combustion zone (in-situ combustion) through a reservoir by air injection into the reservoir.

**Thermonuclear resource:** The aggregate of energy derivable through fusion conversion processes.

**Tight formations:** Sandstone deposits containing natural gas, most commonly found in the Western United States. (Prospective reservoirs generally have low porosities and permeabilities not amenable to conventional completion techniques.)

**TRENDLONG2004:** A Data Resources, Inc. projection of the U.S. economy extending to the year 2004. This projection, made by DRI in December 1979, is one of relatively moderate GNP growth. EIA has adjusted this projection to be consistent with its low, middle, and high forecasts of world oil prices. The adjusted macroeconomic projections are used in making the midterm energy demand projections.

**Trunkline:** A project to import liquefied natural gas into the Southeastern United States from Algeria.

**Undiscovered recoverable resources:** (See Resources.)

**U<sub>3</sub> O<sub>8</sub>:** Uranium oxide, or yellowcake, is the international standard for the form in which uranium concentrate is marketed. Conversion and enrichment of U<sub>3</sub> O<sub>8</sub> results in fuel for the light-water reactor.

**Uranium milling:** The process of crushing, grinding, and chemically treating uranium ore to remove the uranium oxide.

**Waterflooding:** Pressured water injected into reservoirs to provide energy to drive the oil and gas into producing wells, a secondary recovery method.

**Wellhead:** The point at which oil or natural gas is transferred from the well to pipeline or other nonwell facility. This term is used to refer to "wellhead price," which is the price producers of oil and natural gas receive.

**Windfall profits tax:** An excise or severance tax on domestically produced oil, paid by producers

and royalty owners. It is tax on the difference in the price paid for domestically produced oil and the price that would have been paid to produce under oil price controls.

**Yellowcake:** An oxide of uranium used to make nuclear fuel rods after further refinement. Approximately 520 tons of ore must be milled to obtain 1 ton of yellowcake. (See  $U_3O_8$ .)



# Bibliography

## International

Association of Shipbrokers and Agents. *Worldwide Tanker Nominal Freight Scale: Worldscale*. London, England: Association of Shipbrokers and Agents (Worldscale), Inc., July 1978.

This publication provides reference freight rates ("worldscale" rates) for each trade route in the world. These rates include approximately 5000 ports.

Bonner and Moore Associates. *Refinery and Petrochemical Modeling System (RPMS)*. Houston, Tex.: Bonner and Moore Associates Inc., September 1977.

This document describes the database used by the Refinery and Petrochemical Modeling System, which was used to simulate refinery operations.

Brookhaven National Laboratory, National Center for Analysis of Energy Systems. Policy Analysis Division. *Energy Needs, Uses, and Resources in Developing Countries*. Upton, N.Y.: Brookhaven National Laboratory, March 1978.

This report discusses the development and estimation of an econometric model by Brookhaven National Laboratory to be used to forecast the demand for oil, coal, and natural gas by the Organization of Petroleum Exporting Countries (OPEC) and the non-OPEC developing countries for the period 1976 through 1990.

Data Resources, Inc. *World Data*. Lexington, Mass.: Data Resources, Inc., January 1979.

This report provides: (1) data on housing stocks, steel production, and vehicle registrations for OECD member countries for the years 1960 through 1977 (data on housing stocks is only available for selected years); and (2) data on gross domestic product, currency exchange rates, and population for non-OECD International Monetary Fund member countries for the years 1960 through 1975.

Drewery, H.P. *Shipping Statistics and Economics*. London, England: H.P. Drewery (Shipping Consultants) Ltd., August 1979.

This journal provides Average Freight Rate Assessment (AFRA) rates for each tanker size. The costs of transporting crude oil and petroleum products are based on "worldscale" and AFRA rates, and are used in the transportation model.

Gordian Associates. *Special Data for International Supply and Demand Analysis for the National Energy Outlook, Task 2—Liquefied Natural Gas*. New York, N.Y.: Gordian Associates, January 1977.

This report provides data on the costs associated with movement of natural gas by LNG carriers, including liquefaction, stripping, and regasification, as well as distribution charges.

I.C.F., Inc. *Coal Production and Export Projections for Selected Countries—1980, 1985, and 1990*. Washington, D.C.: I.C.F., Inc., September 1979.

This report provides preliminary data on the potential levels of coal production and exports for selected countries. These estimates have been broken down into steam, metallurgical coal, and brown coal for the years 1980, 1985, and 1990.

I.C.F., Inc. *Coal Production and Export Projections for Selected Countries—Rough Estimates for 1995*. Washington, D.C.: I.C.F., Inc., September 1979.

This report provides estimates of coal production and export estimates for 1995. These estimates are based primarily on the assumption that the trends projected for the late 1980's will continue during the 1990–1995 period.

International Bank of Reconstruction and Development. *World Development Report, 1979*. Washington, D.C.: International Bank of Reconstruction and Development, August 1979.

This report provides economic growth projections for the non-OECD countries through 1990.

International Road Federation. *Road and Motor Vehicles Statistics*. Washington, D.C.: International Road Federation, various annual issues.

These reports provide data on vehicle statistics for the years 1973 through 1978.

Logistics Management Institute. *The International Energy Evaluation System*, Volume Two. Washington, D.C.: Logistics Management Institute.

This technical documentation describes the components of IEES and contains several appendices that pertain to some of the more technical aspects of the model.

Nordhaus, William D. "The Demand for Energy: An International Perspective." Cowles Foundation Discussion Paper Number 405, Yale University, September 1975.

This paper reports on the preliminary results of a study of energy demand from an international perspective. This study differs from earlier studies for two reasons: (1) it attempts to estimate the demand for *net* energy in four major sectors of the economy, without regard for the breakdown of the different fuels, and (2) it attempts to compare the energy demand functions of seven Western countries over the period 1952 through 1972, in both individual country estimates and by pooling the data.

Organization for Economic Cooperation and Development. *Basic Energy Statistics*. Data Tape. Paris, France: Organization for Economic Cooperation and Development, 1978.

This data tape provides production and sectoral consumption data on hard coal, patent fuel, coke-oven coke, gas coke, brown coal, bkb, natural gas, manufactured gas (including gas-works gas, coke-oven gas, oil-refinery gas, and blast-furnace gas), crude petroleum, liquefied gases, aviation gasoline, motor gasoline, jet fuel, kerosene, gas/diesel oil, residual fuel oil, naphtha, other nonfuel petroleum products, and electricity for OECD member countries for the years 1960 through 1974.

Organization for Economic Cooperation and Development. *Energy Statistics, 1975-1977*. Paris, France: Organization for Economic Cooperation and Development, 1979.

This report provides production and sectoral consumption data on hard coal, patent fuel, coke-oven coke, gas coke, brown coal, bkb, natural gas, manufactured gas (including gas-works gas, coke-oven gas, oil-refinery gas, and

blast-furnace gas), crude petroleum, liquefied gases, aviation gasoline, motor gasoline, jet fuel, kerosene, gas/diesel oil, residual fuel oil, naphtha, other nonfuel petroleum products, and electricity for OECD member countries for the years 1975 through 1977.

Organization for Economic Cooperation and Development. *Indicators of Industrial Activity*. Paris, France: Organization for Economic Cooperation and Development, various quarterly issues.

These reports provide data on the index of industrial production for selected OECD member countries for the years 1960 through 1977.

Organization for Economic Cooperation and Development. *Main Economic Indicators, 1960-1975*. Paris, France: Organization for Economic Cooperation and Development, October 1976.

This report provides data on disposable income and the index of industrial production for OECD member countries for the years 1960 through 1975.

Organization for Economic Cooperation and Development. *Main Economic Indicators*. Paris, France: Organization for Economic Cooperation and Development, various monthly issues.

These reports provide data on disposable income and the index of industrial production for OECD member countries for the years 1976 and 1977.

Organization for Economic Cooperation and Development. *Oil Statistics, Supply and Disposal*. Paris, France: Organization for Economic Cooperation and Development, annual issues of 1965 through 1977.

These reports provide data on petroleum product trade and sectoral consumption of nonfuel petroleum products for OECD member countries for the years 1965 through 1977.

Organization for Economic Cooperation and Development. *Quarterly Oil Statistics, Third Quarter 1979*. Paris, France: Organization for Economic Cooperation and Development, 1979.

This publication provides data on crude oil and petroleum product imports for all OECD countries. The trade flow for 1978 was used in the transportation sector of the IEES.

Overseas Electrical Industry Survey Institute, Inc. *Electric Power Industry in Japan, 1976*. Tokyo, Japan: Overseas Electrical Industry Survey Institute, Inc., December 1976.

- This publication analyzes the current situation of the electric utility industry in Japan.
- Resource Planning Associates, Inc. *Estimated Impacts of Nonprice Energy Conservation Policies in OECD Countries*. Cambridge, Mass.: Resource Planning Associates, Inc., 1978. (Prepared under contract for U.S. Department of Energy, Energy Information Administration.)
- This report provides conservation savings estimates for OECD member countries for the years 1985 and 1990.
- Statistical Office of the European Communities. *Electrical Energy Statistics, 1976*. Luxembourg: Statistical Office of the European Communities, November 1977.
- This publication provides data on the electrical energy situation in the EEC.
- Statistics Canada. *Electric Power Statistics*. Vol. II, 1976. Ottawa, Canada: Statistics Canada, 1978.
- This report provides annual statistics for the electric power industry and establishments with generating facilities.
- U.S. Department of Energy. Energy Information Administration. *An Analysis of the World Oil Market, 1974-1979*. DOE/EIA-0184/9. Washington, D.C.: U.S. Department of Energy, July 1979.
- This report examines some of the suggested reasons for the petroleum shortfall in 1979 and the degree to which proposed explanations are supported by existing data. Estimates of monthly petroleum production over the last quarter of 1978 and the first quarter of 1979 provide some indication as to the effect of the Iranian disruption on world oil supplies.
- U.S. Department of Energy. Energy Information Administration. *Annual Report to Congress, 1978*, Volume Two. Washington, D.C.: U.S. Department of Energy, April 1979.
- This report provides energy production and aggregate consumption data for the United States for the years 1955 through 1978.
- U.S. Department of Energy. Energy Information Administration. *Energy Data Reports: Supply, Disposition, and Stocks of All Oils by PAD Districts and Imports into the United States by Country*. December 1978. Washington, D.C.: U.S. Department of Energy, April 1979.
- This report provides data on imports of crude oil and petroleum products into the United States by exporting countries in 1978.
- U.S. Department of Energy. Energy Information Administration. *Energy Demand in the Developing Countries*. DOE/EIA-0183/10. Washington, D.C.: U.S. Department of Energy, April 1979.
- This EIA Technical Report documents the non-OECD Demand Model, an econometric model originally developed and estimated by Brookhaven National Laboratory to forecast oil, coal, and natural gas demands of the Organization of Petroleum Exporting Countries (OPEC) and the non-OPEC developing countries for the period 1976 through 1990.
- U.S. Department of Energy. Energy Information Administration. *Energy Demand in the OECD Countries*. Draft. Washington, D.C.: U.S. Department of Energy.
- This EIA Technical Report provides background documentation for the OECD Demand Model used in developing the forecasts of annual energy demand for the non-U.S. member countries of the Organization for Economic Cooperation and Development (OECD) used in the Energy Information Administration's *Annual Report to Congress, 1979*. The report includes an analysis of historical data, a description of the theoretical model, model parameter estimates and statistics, and elasticity matrices.
- U.S. Department of Energy. Energy Information Administration. *Energy Interrelationships*. Washington, D.C.: U.S. Department of Energy, June 1977.
- This report provides conversion factors for refined petroleum products.
- U.S. Department of Energy. Energy Information Administration. *International Energy Prices*. Draft. Washington, D.C.: U.S. Department of Energy.
- This report provides retail prices for gasoline, diesel fuel, kerosene, light fuel oil, heavy fuel oil, gas, coal, and electricity for OECD member countries for the years 1955 through 1977.
- U.S. Department of Energy. Energy Information Administration. *International Petroleum Annual*. 1976 and 1977 editions. Washington, D.C.: U.S. Department of Energy.
- These reports provide retail prices for refined petroleum products including gasoline, kerosene, lubricants, bunker fuel, and distillate fuel oil for selected countries in 1976 and 1977.
- U.S. Department of Energy. Energy Information Administration. *National Energy Outlook*.

Washington, D.C.: U.S. Department of Energy, 1977.

This report provides energy forecasts, including the data on refinery costs used to calculate blending relationships.

U.S. Department of Energy. Energy Information Administration. *Weekly Petroleum Status Report*. DOE/EPC-0041. Washington, D.C.: U.S. Department of Energy, January 1980.

This weekly report provides various statistics for crude oil and petroleum products. The international crude oil prices as of January 1, 1980, were used from this report to generate supply functions in the supply sector of the IEES.

U.S. Department of Energy. Office of International Affairs. *Non-OPEC Oil Supply Projections Through 1995*. Washington, D.C.: U.S. Department of Energy, August 1979.

This report provides projections of free world non-OPEC oil production for 1985, 1990, and 1995 for three cases: low, middle, and high.

U.S. Department of Energy. Office of International Affairs. *OPEC Production Possibilities, 1985-1995*. DOE/IA-31. Washington, D.C.: U.S. Department of Energy, June 1979.

This report provides updated assessments of OPEC production possibilities for the years 1985, 1990, and 1995. These projections are for each OPEC country in three cases: low, middle, and high.

U.S. Department of Energy. Office of International Affairs. *OPEC: Sustained Production Possibilities and Estimated Maximum Sustainable Productive Capacity*. Washington, D.C.: U.S. Department of Energy, February 1980.

This report estimates crude oil and natural gas production possibilities and productive capacities for the years 1985, 1990, and 1995. The data are compiled individually for each OPEC country for three cases: low, middle, and high.

U.S. Department of the Interior. Bureau of Mines. *International Petroleum Annual*. Washington, D.C.: U.S. Department of the Interior, annual issues for 1960-1975.

These reports provide (1) data on retail prices for refined petroleum products including gasoline, kerosene, lubricants, bunker fuel, and distillate fuel oil for selected countries for the years 1963 through 1965 and 1970 through 1975, and (2) data on domestic demand for refined

petroleum products in selected countries for the years 1960 through 1975. Product categories included are gasoline (total including motor and aviation), kerosene and jet fuel, distillate fuel oil, residual fuel oil, lubricants (including grease), other refined products, and refinery fuel and loss.

United Nations. *World Energy Supplies, 1970-1976*. Data Tape. New York, N.Y.: United Nations, 1978.

This data tape provides data on production, imports, exports, additions to stocks, and bunkers for gasoline, kerosene, distillate fuel oil, residual fuel oil, lubricants, other nonfuel petroleum products, refinery fuel and losses, natural gas, coal, lignite, hydroelectricity, and nuclear electricity for United Nations member countries for the years 1970 through 1976.

United Nations. *World Population Outlook*. (Data communicated in a letter of July 22, 1979 to Derriell B. Cato of EIA's Office of Applied Analysis from Alice Hecht of the United Nations.)

This communication provides population forecasts for the OECD member countries for 1980, 1985, 1990, and 1995.

United Nations. *World Population Prospects*. New York, N.Y.: United Nations, 1973.

This report provides data on population growth rates for non-OECD United Nations member countries for the 5-year intervals 1970-1975, 1975-1980, 1980-1985, 1985-1990, and 1990-1995.

Wharton Econometric Forecasting Associates, Inc./SRI International. *World Economic Data Base*. Computer Listing. Philadelphia, Pa.: Wharton EFA, Fall 1979.

This report provides data on gross domestic product, national income exchange rates, population, and price deflators for OECD member countries for the years 1956 through 1978.

## Short Term

Collins, Dwight E., Barcella, Mary L., and Shaw, Michael L. *Short Term Integrated Forecasting System (STIFS) Methodology and Model Descriptions*. Washington, D.C.: Logistics Management Institute, December 1979.

This documentation report provides model descriptions and methodology for the Short-Term Integrated Forecasting System (STIFS).

Data Resources, Inc. *Energy Review—Winter 1980*. Lexington, Mass.: Data Resources, Inc., 1980.

This publication provides comparative forecasts on oil, natural gas, coal, and electric power for the analysis of the short-term supply and demand forecasts.

Data Resources, Inc. *U.S. Forecast Summary*. Lexington, Mass.: Data Resources, Inc., February 25, 1980.

Forecasts of key price and income indicators were taken from DRI national forecasts entitled CONTROL022280, modified by inputting EIA world crude oil price forecasts to the DRI model. Forecasts of the number of autos in the United States were taken from CONTROL032280.

Edison Electric Institute. *1979 Annual Electric Power Survey*. Washington, D.C.: Edison Electric Institute, April 1979.

Forecasts of electric power generation by energy source from this publication are used in comparisons with the 1979 *Annual Report* short-term supply and demand forecasts and similar forecasts by other organizations.

Independent Petroleum Association of America. *Report of the Supply and Demand Committee*. Washington, D.C.: Independent Petroleum Association of America, October 27, 1979.

This publication provides comprehensive petroleum forecasts used in compiling data for comparisons with other forecasts and those in the short-term chapter.

McGraw-Hill, Inc. *Electrical World*. Vol. 192, No. 6. New York, N.Y.: McGraw-Hill, Inc., September 15, 1979.

The *Electrical World* forecast of electric power generations provides a basis for comparative analysis with similar forecasts by EIA and other organizations.

McGraw-Hill Inc. *Keystone Coal Industry Manual 1979*. New York, N.Y.: McGraw-Hill, Inc., 1979.

The "Keystone Manual" provides information concerning current and projected production, production capacity, regional supply patterns, and supply concentrations in the coal industry.

National Energy Reliability Council. *1979 Summary of Projected Peak Load Generating Capability and Fossil Fuel Requirements*. Princeton, N.J.: National Energy Reliability Council, July 1979.

The NERC forecast provides a general reference in the analysis of current and

projected electrical generating capacity and fossil fuel requirements of electrical utilities.

The Pace Company. *The Pace Energy and Petrochemical Outlook to 2000*. Pittsburgh, Pa.: The Pace Company, October 1979.

Forecasts of petroleum, natural gas, coal, and electricity by the Pace Company are used in comparative analysis with forecasts by EIA and other organizations.

Petroleum Publishing Company. *Oil and Gas Journal*. Vol. 78, No. 4. Tulsa, Okla.: Petroleum Publishing Co., January 28, 1980.

The most recent annual petroleum forecasts appearing in the *Oil and Gas Journal* are compared with forecasts of petroleum by other organizations.

Price, Joel. *The Coal Observer*. RI 1433/03-09. New York, N.Y.: Dean Witter Reynolds, Inc., November 1979.

The *Coal Observer* is used to compile data for the short-term coal supply and demand forecast comparison.

Scallop Corporation. *World Oil Outlook*. (Unpublished Report). Houston, Tex.: Royal Dutch/Shell Oil, January 1980.

This unpublished report is used in the comparative analysis of the short-term gasoline and electrical power forecasts.

U.S. Department of Commerce. National Oceanic and Atmospheric Administration. *Monthly State, Regional Heating Degree Days Weighted By Population*. Form 47-318. Washington, D.C.: U.S. Department of Commerce.

This document provides data on regional average heating and cooling degree days used in estimating demand for electricity, residual fuel oil, distillate fuel oil, and motor gasoline.

U.S. Department of Energy. Energy Information Administration. *Energy Data Reports*. Washington, D.C.: U.S. Department of Energy.

The *Energy Data Reports* (EDR) are a series of periodicals documenting energy supply and demand information for the United States. A complete listing and description of EDR's available from the Energy Information Administration is contained in the *EIA Publications Directory*. The following EDR's were used in compiling the databases for the Short-Term Integrated Forecasting System demand models.

"Coke and Coal Chemicals." DOE/EIA-0121.

"Cost and Quality of Fuels for Electric Utility Plants." DOE/EIA-0075.

"Crude Petroleum, Petroleum Products, and Natural Gas Liquids." DOE/EIA-0109.

"EIA Report on Preliminary Power Production, Fuel Consumption, and Installed Capacity." DOE/EIA-0005.

"Natural and Synthetic Gas." DOE/EIA-0130.

"Pennsylvania Anthracite Weekly Production." DOE/EIA-0127.

"Supply, Disposition, and Stocks of All Oils by P. A. D. Districts and Imports into the United States by Country." DOE/EIA-0134.

"Weekly Coal Production." DOE/EIA-0218.

U.S. Department of Energy. Energy Information Administration. *Short-Term Integrated Forecasting System (STIFS) Forecast Validation Procedures*. TR/IA/80-3. Washington, D.C.: U.S. Department of Energy, March 1980.

This report outlines the structure, input data, output variables, and forecast validation procedures of the Short-Term Integrated Forecasting System.

U.S. Department of Energy. Energy Information Administration. *Monthly Energy Review*. DOE/EIA-0035. Washington, D.C.: U.S. Department of Energy, Published Monthly.

This EIA periodical is used as a source for historical data on prices and quantities used to project supply, demand and prices of fuels in the short-term analysis.

U.S. Department of Energy. Energy Information Administration. Petroleum Reporting System. Forms EIA-87, EIA-88, EIA-89, EIA-90, ERA-60, FEA-P133, and FEA-124. Washington, D.C.: U.S. Department of Energy.

These forms are used to determine consumption of distillate and residual fuel oil and motor gasoline.

U.S. Department of Energy. Energy Information Administration. *Short-Term Energy Outlook*. DOE/EIA-0202/1. October 1979. Washington, D.C.: U.S. Department of Energy, October 1979.

U.S. Department of Energy. Energy Information Administration. *Short-Term Energy Outlook*. DOE/EIA-0202/2. February 1980. Washington, D.C.: U.S. Department of Energy, February 1980.

The "Short-Term Outlook" reports provides the data for comparing the 1979 ARC short-term

energy forecasts with EIA projections from October 1979 and February 1980. These reports also contain sections on short-term forecasting methodology used within EIA.

U.S. Department of Energy. Energy Information Administration. *Weekly Petroleum Status Report*. DOE/EIA-0208. Washington, D.C.: U.S. Department of Energy. Published weekly.

This publication provides stock and stock change data for crude oil, motor gasoline, jet fuel, distillate fuel oil, and residual fuel oil.

U.S. Department of Energy. Energy Information Administration. *Western Coal Development Monitoring System, A Survey of Coal Mining Capacity in the West*. Washington, D.C.: U.S. Department of Energy, December 1979.

This report provides historical data and short-term projections of production and production capacity for coal mines west of the Mississippi River. It is used in assessing the effects of production capacity on the coal industry in the short-term analysis.

## Midterm

American Petroleum Institute, American Gas Association, and Canadian Petroleum Institute. *Reserves of Crude Oil, Natural Gas Liquids, and Natural Gas in the United States and Canada as of December 31, 1978*, Volume 33. Washington, D.C.: American Petroleum Institute, June 1979.

The document contains reserves and production data that are used in compiling the databases for both the Midterm Oil and Gas Supply Model and the Short-Term Oil and Gas Supply Model.

Arthur D. Little, Inc. *Energy Conservation in New Building Design, An Impact Assessment of ASHRAE Standard 90-75*. Cambridge, Mass.: Arthur D. Little, Inc.

This report explores the implications of widespread adoption of ASHRAE 90-75. This includes the effects on building energy consumption for a variety of building types and geographical locations, the effect on initial (capital) and operating costs of new buildings, the possible influence on building habitability, the reduction in the Nation's annual energy requirements, and the potential economic impact on selected sectors within the construction industry.

Bonner and Moore Associates. *RPMS Data Base*.

Houston, Tex.: Bonner and Moore Associates, September 1977.

This document describes the database used by the Refinery and Petrochemical Modeling System, which is used to simulate refinery operations for the midterm forecasts.

Energy and Environmental Analysis, Inc. *Industrial Fuel Choice Analysis Model*. Energy and Environmental Analysis, Inc., January 1979.

This report provides a detailed description of the logic and data sources of the Industrial Fuel Choice Analysis Model. The model, which represents industrial fuel choice decisions for conventional technologies, provides midterm forecasts for small boiler and nonboiler fuel use.

Energy and Environmental Analysis, Inc. *Light-Duty Vehicle Fuel Consumption Model, 1975-1986*. Energy and Environmental Analysis, Inc., April 1978.

This summary description of the Light-Duty Vehicle Fuel Consumption Model and the accompanying database.

Federal Highway Administration. *Highway Statistics*. Various annual editions. Washington, D.C.: U.S. Department of Transportation.

This annual report provides the data on the stock of highway vehicles, vehicle use, fuel consumption, and revenues and expenditures associated with highway transportation in the United States that was used in the estimation of gasoline demand. The data used cover the 1960-1978 period.

Federal Power Commission. *Hydroelectric Power Resources of the United States: Developed and Undeveloped*. FPC-P43. Washington, D.C.: Federal Power Commission, January 1976.

This publication lists hydroelectric generating units currently installed, under construction, and planned or projected. Capacity and average annual generation are given for each plant. This information is used to derive average hydroelectric capacity factors and estimates of new hydroelectric generating capacity by DOE region.

Greenberg, H. J. and Murphy, F. H. "Modeling the National Energy Plan," in *Energy Modeling and New Energy Analysis*. Chicago, Ill.: Institute of Gas Technology, August 1978.

This paper documents aspects of the first efforts to analyze the National Energy Plan during its formation, from January to April

1977. The presentation includes both the modeling and the modeling process.

I.C.F., Inc. *Coal and Electric Utilities Model Documentation*. Washington, D.C.: I.C.F., Inc., July 1977.

This report describes the methodology underlying electric resource allocation and mine costing.

Kilkeary, Scott and Associates, Inc. *Documentation of Volume Three of the 1978 Energy Information Administration Annual Report to Congress*, February 1979.

This report documents the analytical process used by the EIA Office of Applied Analysis to develop the economic and energy forecasts published in Volume Three of EIA's *Annual Report to Congress, 1978*. In particular, this document addresses the methodologies underlying the forecasts. It is based on extensive interviews with EIA personnel who prepared the projections and relies on existing detailed model documentation, especially in the midterm chapters.

Lewin and Associates. *Research and Development in Enhanced Oil Recovery: Methodology*, Final Report, Volume 3. HCP/T2294-01/3. Washington, D.C.: U.S. Department of Energy, December 1976.

This report documents the methodology used in the Enhanced Oil Recovery (EOR) Model and includes information on the collection of reservoir data, the economic and technological feasibility of different EOR methods, and the costs of EOR.

Logistics Management Institute. *The Integrating Model of the Project Independence Evaluation System*, Vols. I-VI. DOE Contract No. CR-03-70045-00. Washington, D.C.: Logistics Management Institute, July 1978.

This documents the Midterm Energy Market Model (MEMM), formerly called the Project Independence Evaluation System (PIES). The seven volumes are:

Volume I: Executive Summary

Volume II: Primer

Volume III: User Guide

Volume IV: Model Structure

Volume V: System (Code) Manual

Volume VI: Data Tables

Volume VII: Supplement on the EIA Annual Report to Congress, 1978, Volume Three.

Oak Ridge National Laboratory. *An Econometric-Engineering Analysis of Federal Energy Conservation Programs in the Commercial Sector*. ORNL/CON-30. Oak Ridge, Tenn.: Oak Ridge National Laboratory, January 1979.

This report provides a discussion of the structure of the ORNL Commercial Energy Use Model. The report's primary purpose is to assess various conservation programs.

Oak Ridge National Laboratory. *Commercial Energy Use: A Disaggregation by Fuel, Building Type, and End Use*. ORNL/CON-14. Oak Ridge, Tenn.: Oak Ridge National Laboratory, February 1978.

This report describes the development of detailed estimates of energy use in the commercial sector. Three distinct tasks are performed: (1) data on commercial energy use are reviewed, analyzed, and interpreted to reflect consistent commercial sector coverage; (2) floor space stock estimates are developed; (3) information on relative energy use by building type is synthesized from studies of individual buildings and used, along with aggregate fuel and floor space estimates, to calculate detailed energy use by subsector and year.

Oak Ridge National Laboratory. *Distribution of Energy Use by Mode of Travel: Transportation Energy Conservation Data Book*, Edition 3. ORNL-5493. Oak Ridge, Tenn.: Oak Ridge National Laboratory, February 1979.

This report describes statistics on transportation characteristics by mode.

Oak Ridge National Laboratory. *The Commercial Demand for Energy: A Disaggregated Approach*. ORNL/CON-15. Oak Ridge, Tenn.: Oak Ridge National Laboratory, April 1978.

This report describes the structure and forecasting accuracy of the ORNL Commercial Energy Use Model. The model forecasts annual commercial energy use by 10 building types, 5 end uses, and 4 fuel types. Both economic factors (utilization rate, fuel choice, capital energy substitution) and technological factors (equipment efficiency, thermal characteristics of buildings) are explicitly represented in the model.

Oak Ridge National Laboratory. *Procedure for Estimating Non-fuel Operating and Maintenance Costs for Large Steam-Electric Powerplants*. ORNL/TM-6467. Oak Ridge, Tenn.: Oak Ridge National Laboratory.

This model estimates detailed nonfuel operation and maintenance costs for fossil fuel-fired generating plants. An engineering estimate is produced using detailed labor and material costs. The output of this model was used to develop operation and maintenance costs for coal-fired powerplants.

Oak Ridge National Laboratory. *The ORNL Engineering-Economic Model of Residential Energy Use*. ORNL/CON-24. Oak Ridge, Tenn.: Oak Ridge National Laboratory, July 1978.

This report describes the methodology used to simulate energy use in the residential sector from 1970 through 2000. The present version of the model deals with four fuels, eight end uses and three housing types. Each of these fuel-use components is calculated each year as a function of stocks of occupied housing units and new construction, average housing size, equipment ownership by fuel and end use, thermal performance of housing units, average unit energy requirements for each equipment type, and usage factors that reflect household behavior. This report summarizes structure, inputs, validation, and operation of the model.

Synergy, Inc. *Final Documentation Report on the Demand Analysis System*. December 1979.

This is a three-volume set describing the Demand Analysis System as it was used for the EIA's *Annual Report to Congress, 1978*, Volume Three.

Teknekron Research, Inc. *Data Notebook, Generating Technology Assessment*. DOE Contract No. EI 10480. Berkeley, Calif.: Teknekron Research, Inc., January 1980.

This document contains cost and engineering data for conventional and nonconventional technologies. The information was used to provide capital costs, operation and maintenance costs, and heat rates for the MEFS electric utility dispatch model.

Texas Energy Advisory Council. *Texas National Energy Modeling Project: An Experience in Large-scale Model Transfer and Evaluation*. Draft. Texas Energy Advisory Council, March 1979.

This report provides an independent evaluation of the Energy Information Administration's MEFS model. The evaluation provides guidance to users of MEFS, and suggests improvements in the model structure and in the procedures used by EIA for increasing model credibility.

U.S. Department of Energy. Energy Information



Administration. *A Sensitivity Analysis of World Oil Prices*. AR/IA/79-47. Washington, D.C.: U.S. Department of Energy, September 1979.

This EIA Analysis Report presents a sensitivity analysis of the impact of the supply disruption in Iran on the world oil market. The analysis focuses on two critical factors in the oil market: the world oil price and the level of OPEC oil production in the short term and midterm. The assumptions were provided by the Central Intelligence Agency. This report also presents a detailed comparison of forecasting models of world oil prices used by the Central Intelligence Agency and the Energy Information Administration.

U.S. Department of Energy. Energy Information Administration. *Alaskan Hydrocarbon Supply Model: Data Documentation*. MDM/ES/79. Washington, D.C.: U.S. Department of Energy, June 1979.

This document explains the resource and cost data used to compile the database for the Alaskan Hydrocarbon Model, which was used to generate midterm supply forecasts for that portion of Alaska north of the Brooks Range. Included are resource data, field costs for onshore oil, field costs for onshore gas, field costs for offshore oil and gas drilling and production, oil pipeline costs, gas pipeline costs, and terminal and transshipment costs.

U.S. Department of Energy. Energy Information Administration. *Alaskan Hydrocarbons Supply Models: Installation Manual*. Washington, D.C.: U.S. Department of Energy, January 1980.

This manual provides information on installing the Alaskan Hydrocarbons Supply Model (AHSM) on an IBM 360 or 370 computer. A magnetic tape containing the necessary job control language (JCL) statements and data normally accompanies this document.

U.S. Department of Energy. Energy Information Administration. *Alaskan Hydrocarbon Supply Model: Methodology Description*. DOE/EIA - 0103/22. Washington, D.C.: U.S. Department of Energy, January 1979.

This document explains the methodology of the Alaskan Hydrocarbon Model, which was used to generate midterm supply forecasts for that portion of Alaska north of the Brooks Range. Included are detailed descriptions of the modeling strategies used to simulate the Alaskan oil and gas resource base, including the

undiscovered portion; to forecast production from that base under differing economic conditions; and to simulate the construction of pipeline links for the delivery of oil and gas produced in remote regions.

U.S. Department of Energy. Energy Information Administration. *Alaskan Hydrocarbons Supply Model: User's Guide*. Draft. Washington, D.C.: U.S. Department of Energy.

This report describes the operating procedures for the Alaskan Hydrocarbons Supply Model. It includes the names and locations of data files and programs and describes the job control statements required to run the model. Additionally, it provides an annotated program listing of the key segments of the model.

U.S. Department of Energy. Energy Information Administration. *An Evaluation of Natural Gas Pricing Proposals*. DOE/EIA-0102/10. Washington, D.C.: U.S. Department of Energy, June 1978.

This EIA Analysis Report presents the results of analysis of several natural gas pricing proposals. It also illustrates how the Midterm Energy Market Model (MEMM) represents regulatory structures and how it is used for analysis.

U.S. Department of Energy. Energy Information Administration. *An Ex-Post Comparison of the Performance of the 1973 Version of the Project Independence Evaluation System*. TR/EUA/79-33. Washington, D.C.: U.S. Department of Energy, December 1979.

This report examines the performance of the 1973 version of the Project Independence Evaluation System (PIES) model in predicting actual energy production and consumption for 1977. This examination consists of an ex-post comparison of actual and forecasted energy consumption and production; a comparison of the forecast with those produced by other models, including judgmental models; and a discussion of the PIES forecast in light of published shortcomings of this model.

U.S. Department of Energy. Energy Information Administration. *Enhanced Oil Recovery Model: Model Description*. Draft. Washington, D.C.: U.S. Department of Energy.

This report is one of a series documenting the Enhanced Oil Recovery Model. The methodology and model description provide an understanding of the approach used to develop

midterm projections of the domestic supply potential from enhanced oil recovery methods. The computer-based model projects on an annual basis U.S. tertiary production potential for five enhanced oil recovery methods under various scenarios and economic conditions.

U.S. Department of Energy. Energy Information Administration. *Enhanced Oil Recovery Model: System Guide*. Washington, D.C.: U.S. Department of Energy, January 1980.

This document describes the computer implementation of the Enhanced Oil Recovery Model for use in installing the model on a user's computer. All appropriate Job Control Language (JCL) and operating procedures information are included for installing, testing, and utilizing the model on IBM 360/370 computers. To introduce the new user to the model's operational functions, a section describing the overall flow of model processing is included. Details of model functioning and input and output formats are not described; they are covered in other model documentation.

U.S. Department of Energy. Energy Information Administration. *Enhanced Oil Recovery Model: User Guide*. Draft. Washington, D.C.: U.S. Department of Energy.

This report constitutes a detailed description of the Enhanced Oil Recovery Model's operating procedures, including names and locations of input files and computer programs, naming conventions and required job control statements. It is intended for the use of staff who actually operate the model on the computer.

U.S. Department of Energy. Energy Information Administration. *Estimates of Energy Non-Resource Costs: Energy Taxes and Subsidies*. AR/EUR/79-45. Washington, D.C.: U.S. Department of Energy, December 1979.

This EIA Analysis Report provides quantitative estimates of selected tax and subsidy programs that affect the marginal costs of producing and consuming different energy sources. Estimates are presented for each major fuel for the years 1979, 1985, 1990, and 1995. The tax and subsidy programs selected for study are unrelated to any direct valuation of resources used in the production or consumption of major fuels. The estimates of tax and subsidy impacts can be used with the Analysis Reports, *Projecting Marginal Energy Costs Using the Midterm Energy Forecasting System*, AR/EUA/79-43,

and *Marginal Costs of Energy in 1979: Estimates by Economic Sector and Fuel Type*, AR/EUA/79-44, to isolate the direct resource costs of alternative energy sources.

U.S. Department of Energy. Energy Information Administration. *Estimates of the Electric Utility Industry's Capital Requirements for Construction Work in Progress, 1980-1990*. SR/ES/79-20. Washington, D.C.: U.S. Department of Energy, 1979.

This EIA Service Report was prepared at the request of the Energy and Mineral Division of the General Accounting Office. It provides estimates of the capital expenditures related to the projected construction work in progress for the electric utility industry during the next 10 years. The report presents the results of computer runs using the Capital Requirements Estimating Model (CREMOD) interfaced with projections of the electric utility industry's capacity expansion from the Midterm Energy Forecasting System (MEFS) for Scenario C-High of the Energy Information Administration's *Annual Report to Congress, 1978*.

U.S. Department of Energy. Energy Information Administration. *State Energy Data Report*. DOE/EIA-0214(78). Washington, D.C.: U.S. Department of Energy, April 1980.

This report provides estimated State-level economic consumption data by fuel and by economic sector. It also explains the data sources and construction methodology.

U.S. Department of Energy. Energy Information Administration. *Marginal Costs of Energy in 1979: Estimates by Economic Sector and Fuel Type*. AR/EUA/79-44. Washington, D.C.: U.S. Department of Energy, December 1979.

This EIA Analysis Report provides national estimates of marginal energy costs in 1979, for each economic sector and major fuel type. An introduction to marginal energy costs and energy replacement costs, as well as a description of the procedures for obtaining estimates of 1979 marginal energy costs are presented. This report can be used with the Analysis Report, *Projecting Marginal Energy Costs Using the Midterm Energy Forecasting System*, AR/EUA/79-43, to obtain a time series of marginal costs estimates over the 1979 to 1995 period.

U.S. Department of Energy. Energy Information Administration. *Midterm Oil and Gas Supply*

*Modeling System: Methodology Description.* DOE/EIA-0103/17. Washington, D.C.: U.S. Department of Energy, November 1978.

This document explains the methodology used by the Midterm Oil and Gas Supply Modeling System, which was used to forecast midterm supply of oil and gas for the Lower-48 States and South Alaska. It contains a description of the oil and gas resource base and the economic and technological factors pertinent to the development of this base. It shows how the supply model simulates such processes through submodels that translate the resource base into production estimates, calculate minimum acceptable prices for development and production to occur, and simulate drilling activity.

U.S. Department of Energy. Energy Information Administration. *Midterm Oil And Gas Supply Model: System Guide.* MDR/ES/79-01. Washington, D.C.: U.S. Department of Energy, November 1979.

This report is one in a series documenting the Midterm Oil and Gas Supply Model. This system guide provides an overview of the model organization and computer implementation. It also contains detailed instructions for installing the model on another computer. The Midterm Oil and Gas Supply Model is a computer-based model that projects domestic oil and natural gas production for 30 years, based on economic and engineering factors that affect oil and gas supply.

U.S. Department of Energy. Energy Information Administration. *Midterm Oil and Gas Supply Model: User Guide.* Draft. Washington, D.C.: U.S. Department of Energy.

This report constitutes a detailed description of the Midterm Oil and Gas Model's operating procedures, including names and locations of input files and computer programs, naming conventions, and required job control statements. It is intended for the use of staff who actually operate the model on the computer.

U.S. Department of Energy. Energy Information Administration. *Oil and Gas Model, 1977 Data Update.* RM/78-015. Washington, D.C.: U.S. Department of Energy, December 1977.

This document describes a major updating of the database for the Midterm Oil and Gas Modeling System.

U.S. Department of Energy. Energy Information

Administration. *Oil and Gas Supply Curves for the Administrator's Annual Report.* TM/ES/78-17. Washington, D.C.: U.S. Department of Energy, September 1978.

This document provides examples of the output of the Midterm Oil and Gas Modeling System when used to forecast supply possibilities as input for the Midterm Energy Market Model (MEMM).

U.S. Department of Energy. Energy Information Administration. *Pricing Provisions of the Natural Gas Policy Act Of 1978.* AR/EA/79-46. Washington, D.C.: U.S. Department of Energy, December 1979.

This EIA Analysis Report examines the wellhead and incremental pricing provisions of the Natural Gas Policy Act. It provides a qualitative assessment of how the market is displaced in a relatively unregulated market.

U.S. Department of Energy. Energy Information Administration. *Projecting Marginal Energy Costs Using the Midterm Energy Forecasting System.* AR/EUA/79-43. Washington, D.C.: U.S. Department of Energy, December 1979.

This EIA Analysis Report describes procedures incorporated into the Midterm Energy Forecasting System (MEFS) for projecting the marginal costs of producing, processing, converting, and distributing various forms of energy to users in each economic sector and Department of Energy region. It also provides samples results consistent with the Projection Series in the EIA's *Annual Report to Congress, 1979, Volume Three.*

U.S. Department of Energy. Energy Information Administration. *Projections of Enhanced Oil Recovery, 1985-1995.* TR/ES/79-30. Washington, D.C.: U.S. Department of Energy, September 1979.

This report provides estimates of the potential production from enhanced oil recovery methods for the 1985-1995 period that were used in the EIA *Annual Report to Congress, 1978.* These estimates are developed for five scenarios on alternative crude oil prices, assuming that current enhanced oil recovery techniques will attain commercial application and command a rate of return consistent with that for conventional techniques. Estimates of production are provided for thermal recovery methods, gas flooding, and chemical flooding.

U.S. Department of Energy. *International Coal*

*Trade Analysis Forecast*. Washington, D.C.: U.S. Department of Energy, January 1979.

This publication was used to estimate coal exports in 1985, 1990, and 1995.

U.S. Department of Energy. *Trends in Refinery Capacity and Utilization*. DOE/RA-0010. Washington, D.C.: U.S. Department of Energy, September 1978.

This document details, at both the regional and national levels, the trends in the expansion and utilization of domestic refinery capacity. It was the basis for capacity projections used by the Refinery and Petrochemical Modeling System to forecast domestic refinery operations in the midterm.

U.S. Geological Survey. *Geological Estimates of Undiscovered Recoverable Oil and Gas Resources in the United States*. USGS Circular 725. Reston, Va.: U.S. Department of Interior, 1975.

This circular presents the resource assessments that were the basis for estimates of undiscovered recoverable oil and gas resources used in the Midterm Oil and Gas Modeling System.

U.S. Geological Survey. Interim revised estimates of undiscovered recoverable oil and gas resources of the United States. Memorandum from Charles D. Masters, Chief, Office of Energy Resources to Lincoln Moses, Administrator, Energy Information Administration. December 21, 1979.

This memo updates for certain regions of the country estimates of undiscovered recoverable oil and gas resources that had been published in the USGS Circular 725. These are interim estimates only pending completion of the study.

## Long Term

Adler, R. J., Cazalet, E. G., Hass, S. M., Marshalla, R. A., Nesbitt, D. M., and Phillips, R. L. *The DFI Energy-Economy Modeling System*. Palo Alto, Calif.: Decision Focus Inc., December 1978.

This report documents the DFI modeling system, which is the basis for the EIA Long-term Energy Analysis Program (LEAP). LEAP consists of a series of process models and an iterative solution procedure that gives equilibrium prices and quantities.

Aerospace Corporation. *High Temperature Industrial Process Heat, Technology Assessment and Introduction Rationale*. E(04-3)-1101. El

Segundo, Calif.: U.S. Department of Energy, March 1978.

This report makes an assessment of the demand for high-temperature process heat in U.S. industry and the possible role of solar thermal power in satisfying that demand.

Argonne National Laboratory. *Energy Impacts of OTP Programs, Edition I*. Chicago, Ill.: Argonne National Laboratory, 1979.

This report summarizes the conservation activities of the Department of Energy, Office of Transportation Programs, and presents projections of anticipated energy savings associated with those programs. Activities covered include hardware programs, operating strategies, and regulatory intervention.

Argonne National Laboratory. *Projections of Direct Energy Consumption By Mode: 1975-2000 Baseline*. Chicago, Ill.: Argonne National Laboratory, 1979.

This report is in the Transportation Projection Book Series sponsored by the Department of Energy to develop a comprehensive and consistent set of projections for use in the analysis of programs sponsored by the Office of Transportation Programs. The research conducted for the volume emphasizes projections of energy use by mode of transportation.

BDM Corporation. *Photovoltaics Incentives Options, Preliminary Report*. Contract No. DAAK-70-77-D-0023. McLean, Va.: Department of Energy, August 1978.

This report is the source of the photovoltaic plant block diagram used in the Teknekron Research Inc. draft report, "A Guide for the Assessment of Electric Generating Technologies."

Bennemann, J. R. "Biomass Energy Economics." *The Energy Journal*, Vol. 1, Number 1. January 1980.

This article is a general discussion of the economics of biomass production and conversion and includes a comparison of U.S. and foreign experience.

Bhagat, N., Beller, M., Hermelee, A., Wagner, J., and Lamontagne, J. *Evaluation of Technological Data in the DFI and PIES Models*. BNL 50949. Upton, N.Y.: Brookhaven National Laboratory, April 1979.

This report evaluates the PIES and SRI-Gulf conversion data, offering alternative data,

reasons for the different estimates, and a list of references. This report was used in preparing the LEAP database for the EIA long-term forecast.

Bonneville Power Administration. *MOD-2: New Sources of Power for the Pacific Northwest*. Washington, D.C.: U.S. Department of Energy, January 1980.

This report is the source of the MOD-2 power curve used in the Teknekron Research Inc. draft report, "A Guide for the Assessment of Electric Generating Technologies."

Carlson, R., Center for the Biology of Natural Systems. *Preliminary Analysis of Economics of Scale in Grain Alcohol Production*. CBNS-AEP-2. St. Louis, Mo.: Washington University, March 1979.

This report presents an analysis of the economics of alcohol production facilities. It concludes that alcohol production is currently competitive, especially for farm use, and that small-scale plants are at least as economical as large-scale plants.

Carpenter, D. J. and Thomas, D. A. "Low-grade Refinery Heat Recovery Merits Attention." *Oil and Gas Journal*, January 28, 1980.

This article discusses methods for recovery of low-grade process heat. Particular attention is given to the use of industrial heat pumps.

Cazalet, E. G. *Generalized Equilibrium Modeling: The Methodology of the SRI-Gulf Energy Model*. Menlo Park, Calif.: Stanford Research Institute, May 1977.

This report provides an overview of the SRI-Gulf methodology, which is the basis for the DFI modeling system.

Cohen, R. *An Overview of the U.S. OTEC Development Program*. Washington, D.C.: U.S. Department of Energy, 1978. Invited paper for ASME 1978 Energy Technology Conference, Houston, Texas, November 1978, reprinted from American Society of Mechanical Engineers publication *OED - Volume 5*.

This paper describes the status of engineering development and future commercial prospects of Ocean Thermal Energy Conversion (OTEC). It summarizes the U.S. program for development and testing of system hardware, with emphasis on heat exchangers.

Data Resources, Inc. *Energy Review*. Vol. 4, Number 1. Lexington, Mass.: Data Resources, Inc., Winter 1980.

This is the reference document used to obtain the DRI forecast for the comparison in Chapter 5.

Exxon Company, U.S.A. *Energy Outlook 1980-2000*. New York, N.Y.: Exxon Company, December 1979.

This is the reference document used to obtain the Exxon forecast for the comparison in Chapter 5.

Fassbender, L., Battelle Pacific Northwest Laboratories. Personal communication to Dr. Fred Able, January 1980.

The letter is a response to an EIA request, through DOE's Assistant Secretary for Resource Applications, to provide geothermal direct heat data. Included were a resource curve and basic parameters for residential, commercial, and industrial end-use sectors.

Jack Faucett Associates, Inc. *TEC: Transportation Energy Conservation Model*. Submitted to the Division of Transportation Energy Conservation, DOE. Chevy Chase, Md., 1978.

This report presents a detailed description of the Transportation Energy Conservation Model, which can compute estimates of petroleum product savings resulting from technological shifts and policy directions. Baseline projections by mode through 2025 appear in the Appendix.

Freeman, J. R. *Gross Cost Estimates, Relative and Cost Uncertainty Estimates for Synfuels Production Facilities*. Draft. Vienna, Va.: Evaluation Research Corporation, February 15, 1980.

This unpublished paper investigates the factors involved in making cost estimates of synthetic oil and gas and shale oil production facilities. The cost escalation factors used for new technologies have been developed by E. W. Merrow, who is cited in this bibliography. The study suggests that cost uncertainties are larger than cost differences among processes.

General Electric Company, Space Division. *Wind Energy Mission Analysis*. Valley Forge, Pa.: U.S. Energy Research and Development Administration, February 1977.

This report provides a broad overview of issues relating to wind energy utilization. It contains information on wind availability, conversion technology, and costs in several types of application. It discusses impacts of and barriers to implementation.

Interagency Geothermal Coordinating Council.

*Third Annual Report, Geothermal Energy Research Development and Demonstration Program.* Washington, D.C.: U.S. Department of Energy, March 1979.

This report describes activities of Federal, State, and local governments in stimulating geothermal development. It includes a resource assessment, utilization estimates, and a discussion of programs and activities.

Lewin and Associates Inc. *Enhanced Recovery of Unconventional Gas*, Volume I. HCP/T270501. Washington, D.C.: U.S. Department of Energy, October 1978.

This document was the basis for the long-term estimates of undeveloped recoverable resources for enhanced gas recovery.

Lord, N., Curto, P., and True, S. *Solar Thermal Repowering, Utility Industry Market Potential in the Southwest.* McLean, Va.: The MITRE Corporation, December 1978.

This study analyzes the potential for retrofitting solar thermal units as fuel savers for utility oil- and gas-using steam turbines and industrial process heat sites. The economics of and industry's reaction to this application of solar energy are presented.

Marrow, E. W. "Cost Estimation Errors in Energy Process Plants," July 16, 1979. Statement delivered to Subcommittee on Oversight and Investigations; to Subcommittee on Energy and Power, House Committee on Interstate and Foreign Commerce; and to Subcommittee on Energy Development and Application, House Committee on Science and Technology.

This statement summarizes the conclusions of the Rand report by the same author entitled, *A Review of Cost Estimation in New Technologies: Implications for Energy Process Plants*. A transcript of a question and answer period that followed the presentation is included.

Marrow, E. W., Chapel, S. W., and Worthing, C. A. *A Review of Cost Estimation in New Technologies: Implications for Energy Process Plants.* R-2481-DOE. Santa Monica, Calif.: The Rand Corporation.

This report reviews the literature and data on cost estimation in several areas involving major capital expenditure programs, including energy projects. The study investigates past industry experience, the factors associated with errors in estimation, and the implications of this information for DOE planning. It shows that

final costs of projects in constant dollars are generally about three times initial estimates, with an uncertainty of about one.

Miller, B. M., Thomsen, H. L., Dolton, G. L., Coury, A. B., Hendricks, T. A., Lennartz, F. E., Powers, R. B., Sable, E. G., and Varnes, K. L. *Geological Estimates of Undiscovered Recoverable Oil and Gas Resources in the United States.* Circular 725. Reston, Va.: U.S. Geological Survey, 1975.

This report provides detailed estimates of U.S. oil and gas resources. Low, high, and mean values are summarized for the various provinces and groups of provinces or regions.

MITRE Corporation. *Comparative Economic Assessment of Ethanol from Biomass.* HCP/ET-2854. Washington, D.C.: U.S. Department of Energy, September 1978.

This report contains a review of 14 studies and reports evaluating the economics of ethanol production. Using information contained in these reports, the METREK Full Life Cycle Cost model, and the METREK SPURR model, life cycle costs of ethanol production were computed.

MITRE Corporation. *Near Term Potential of Wood as a Fuel.* HCP/C-4101. Washington, D.C.: U.S. Department of Energy, January 1979.

This report evaluates the resources, technology, and economics of deriving useful energy from wood.

National Academy of Sciences. National Research Council. Committee on Nuclear and Alternative Energy Systems. *Energy in Transition 1985-2010.* Washington, D.C.: National Academy of Sciences, December 1979.

This is the reference document used to obtain the CONAES forecast for the comparison in Chapter 5.

National Transportation Policy Study Commission. *National Transportation Policies through the Year 2000.* Washington, D.C.: National Transportation Policy Study Commission, 1979.

This report analyzes the transportation needs, resources, requirements, and policies of the United States through the year 2000. The report covers transportation activity and institutions, forecasts to 2000, emerging transportation issues, policy recommendations, and the implications of these recommendations.

Oak Ridge National Laboratory. *Transportation Energy Conservation Data Book: Edition 2.* Oak

Ridge, Tenn.: Oak Ridge National Laboratory, 1977.

This report is a compilation of transportation data, such as (1) modal characteristics; (2) current energy use, efficiency, and conservation; (3) projections of modal energy use; (4) supply and cost of energy; and (5) impact of Government activities. A wide variety of sources is represented for comparison.

Poor, R. H., and Hobbs, R. B. *The General Electric MOD-1 Wind Turbine Generation Program*. Valley Forge, Pa.: General Electric Company, Space Division.

This report was the source of the MOD-1 power curve used in the Teknekron Research Inc. draft report, "A Guide for the Assessment of Electric Generating Technologies."

Probstein, R. F., and Gold, H. *Water in Synthetic Fuel Production, the Technology and Alternatives*. Cambridge, Mass.: The MIT Press, 1978.

This volume provides a thorough discussion of synthetic fuels technologies, with special attention to how synthetic parameters affect their demands for water. It was a primary source for the long-term water resource curve.

Schroder, G. U.S. Department of Energy. "Economies of Small-scale Alcohol Production," *The Energy Consumer*. Washington, D.C.: U.S. Department of Energy, January 1980.

This article by a small-scale alcohol producer outlines some reasons why farm-based alcohol production plants may be more economical than larger scale plants.

Schooley, F. A., Dickenson, R. L., Kohan, S. M., Jones, J. L., SRI International. *Mission Analysis for the Federal Fuels from Biomass Programs*, Volume I. Menlo Park, Calif.: U.S. Department of Energy, December 1978.

This study describes an analysis of the market penetration of various biomass "missions" or conversion routes from feedstock, through conversion, and final product. Using SRI's supply-demand equilibrium model, projections of product output were obtained through 2020. Assumptions of resource availability and technological parameters were included.

Stanford Research Institute. *Fuel and Energy Price Forecasts*, Volume II. EPRI EA-433. Palo Alto, Calif.: Electric Power Research Institute, February 1977.

This report gives a detailed documentation of

the SRI-Gulf database, which served as an initial database for the LEAP forecast.

Teknekron Research, Inc. *A Guide for the Assessment of Electric Generating Technologies*. Draft Report. 79EI-10480. Berkeley, Calif.: U.S. Department of Energy, February 1980.

This is a contracted report done for the Office of Applied Analysis, Energy Information Administration. It covers both conventional and new electric generating technologies and includes the following types of information: general description, history, engineering and cost specifications, and technical and institutional considerations for market penetration.

U.S. Bureau of Mines. *Demonstrated Coal Reserve Base of the United States on January 1, 1976*. Washington, D.C.: U.S. Department of the Interior, August 1977.

This report evaluates the Geological Survey data on identified coal deposits at depths of less than 3000 feet. A determination is made of the quantity of coal in relatively thick beds and near enough to the surface to be mined by conventional surface or underground methods.

U.S. Department of Energy. *Commercialization Strategy Report for Large Wind Systems*. TID-28843. Washington, D.C.: U.S. Department of Energy.

This report was the source of the ALCOA vertical-axis wind turbine power curve as used in the Teknekron Research Inc. draft report, "A Guide for the Assessment of Electric Generating Technologies."

U.S. Department of Energy. Energy Information Administration. *Research into the Methodology of the LEAP Model*. DOE/EIA-451887. Washington, D.C.: U.S. Department of Energy, December 1979.

This report investigates mathematical programming and related aspects of the LEAP methodology. Of specific interest are two questions: (1) does the LEAP algorithm have an equivalent mathematical programming problem (MPP) that is deterministic; and (2) can any related MPP algorithms or concepts accelerate convergence or prove the stability of the LEAP solution. The results of the report show why LEAP has no deterministic equivalent MPP and that the procedure's only analog is the solution of simultaneous nonlinear equations. Several results are established, and a series of solution algorithms are proposed and evaluated.

U.S. Department of Energy. *Geothermal Progress Monitor*. Washington, D.C.: U.S. Department of Energy, December 1979.

This periodical monitors and reports commercialization activities in the geothermal industry.

U.S. Department of Energy. Office of the Assistant Secretary for Environment. *An Assessment of National Consequences of Increased Coal Utilization*, Executive Summary. TID 29425. Washington, D.C.: U.S. Department of Energy, February 1979.

This report provides information on the effects of increased coal utilization, including the effects on water resources. A tabulation is included of the available quantities of and demands for water in each of 101 regions in the United States.

U.S. Department of Energy. *Photovoltaics Program Multi-Year Plan*, Draft. Washington, D.C.: U.S. Department of Energy, May 7, 1979.

This document outlines the U.S. Department of Energy Photovoltaic Systems Program. It describes the technology, component costs, and various stages of the Department's programs for fostering wider use of photovoltaics.

U.S. Department of Energy. Energy Information Administration. *Solar Collector Manufacturing Activity, January through June 1979*. Washington, D.C.: U.S. Department of Energy, October 1979.

This report presents the results of a survey of solar equipment manufacturers. It contains information on the square feet of collectors shipped, with disaggregations by temperature, application, and headquarters location of the companies.

U.S. Energy Research and Development Administration. *Solar Program Assessment: Environmental Factors, Fuels from Biomass*. Washington, D.C.: U.S. Energy Research and Development Administration, March 1977.

This report provides a review of the basic concepts of biomass technology and biomass resource requirements, as well as an assessment of the environmental impacts of increased production.

U.S. Geological Survey. *Assessment of Geothermal Resources of the United States—1978*. Circular 790, L. J. P. Muffler, ed. Arlington, Va.: U.S. Department of the Interior, 1979.

This Volume presents the Survey's geothermal resource assessment data and is a refinement and updating of USGS Circular 726. It discusses five categories of geothermal energy and includes three colored maps showing geothermal resource locations.

U.S. Geological Survey. *Coal Resources of the United States, January 1, 1974*. Bulletin 1412. Washington D.C.: U.S. Department of the Interior, 1975.

This report provides a detailed estimate of U.S. coal resources by State, rank, and amount of overburden.

Williams, J. R. *Solar Energy, Technology and Applications*. Ann Arbor, Mich.: Ann Arbor Science Publishers, Inc., 1974.

This is a general text on solar energy, which covers solar availability and the range of conversion technologies. Some economic information is included.



# Appendix A: Methodology

## METHODOLOGY OVERVIEW

This appendix provides an overview of the basic modeling systems used in developing the energy projections presented in this year's *Annual Report to Congress*. The material is divided into four sections, corresponding to the principal sections of the report:

- A.1 The International Energy Evaluation System (IEES)
- A.2 The Short-Term Integrated Forecasting System (STIFS)
- A.3 The Midrange Energy Forecasting System (MEFS)
- A.4 The Long-Range Energy Analysis Program (LEAP)

Each section provides a general summary overview of the methodology. A more detailed description is available from reports indicated in the Bibliography. The IEES, MEFS, and LEAP methodologies used in this year's *Annual Report to Congress* are conceptually similar to those used in earlier work. However, important improvements have been incorporated to reflect the changing energy markets that the modeling systems represent. The STIFS methodology is completely different from previously used methods, and provides a comprehensive new modeling framework for both this year's *Annual Report to Congress* and the quarterly *Short-Term Energy Outlook*.

### A.1 THE INTERNATIONAL ENERGY ANALYSIS METHODOLOGY

#### Introduction

The methodology for international energy analysis centers around two basic modeling systems: the International Energy Evaluation System (IEES) and the Oil Market Simulation (OMS) model. The IEES is an international energy fore-

casting model used by the Energy Information Administration's (EIA) Office of Applied Analysis to provide alternative forecasts of energy prices, supplies, demands, and conversion activities. For selected years—currently 1985, 1990, and 1995—the IEES provides forecasts of consumption levels and market prices for major fuels in the Organization for Economic Cooperation and Development (OECD) countries and patterns of activity in each of the major energy industries, including electric utilities, oil and gas production, coal mining, and refineries. The OMS model is discussed under the section entitled, "World Oil Prices."

The IEES framework consists of three major components: demand models, supply models, and an integration model that balances supply and demand by adjusting prices and quantities until a multiproduct-multiregion equilibrium is reached. The overall relationship of these major components is depicted in Figure A.1a.

The demand model consists of several component models that estimate consumer demands for fuels and energy as functions of prices and economic growth for OECD countries (except the United States) and non-OECD countries. Inputs for the United States are taken from the Midrange Energy Forecasting System (MEFS). The supply network specifies numerous supply options for the energy products needed to satisfy demands. The network is formed from several models that represent extraction, conversion, and transportation activities.

Demand is governed by the general level of economic activity, the nature and extent of conservation programs, and other demand-related scenario assumptions. Demands for refined petroleum products, natural gas, coal, and electricity are estimated for each of the 33 IEES regions.

The IEES supply component is represented by a network that models the flow of fuels from production through conversion to points of consumption. Figure A.1b is a schematic of these material flows. In establishing the supply representation, a set of models is used for primary fuel

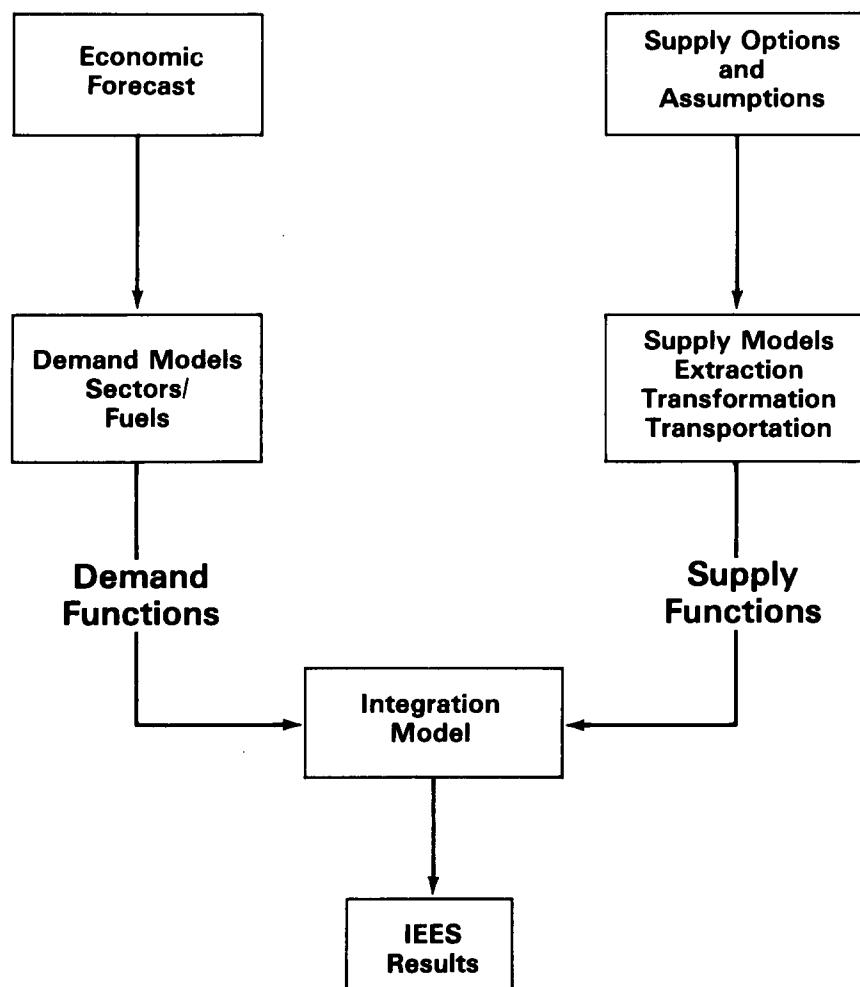

**Figure A.1a Schematic of the IEES Integrating Framework**

supply, refineries, electricity, synthetic fuel production, and transportation. These models form the integrated supply network and simulate the response of the specific industries to price changes. The various parts of IEES are linked by distribution networks that represent the movement of raw materials or products from the points of production or conversion to the points of consumption.

The principal economic assumptions that are implicit in the IEES model structure follow:

- Market equilibrium conditions govern the purchase prices and quantities of fuels in the OECD countries (other than the United States) in such a way that the sum of consumers' and producers' surpluses is maximized across all OECD countries (except the United States) and across all energy industry sectors.
- Similar conditions govern prices and quanti-

ties in the United States, although it is considered to be a separate entity.

- Energy demands in the non-OECD countries are functions of factors such as gross domestic product, population, and the ability of each country to finance the purchase of imports.
- In the OECD countries, consumers are prepared to substitute fuels on the basis of their relative prices.
- No resource constraints exist other than those for fuels (i.e., no restrictions exist on the availability of capital, manpower, cooling water, steel, concrete, etc.).
- All products are purchased and all investments are made on the basis of the marginal prices of the products (except for electricity, which is sold at an average-cost price).

The use of alternative scenarios permits evaluation and analysis of specific issues. Essentially,

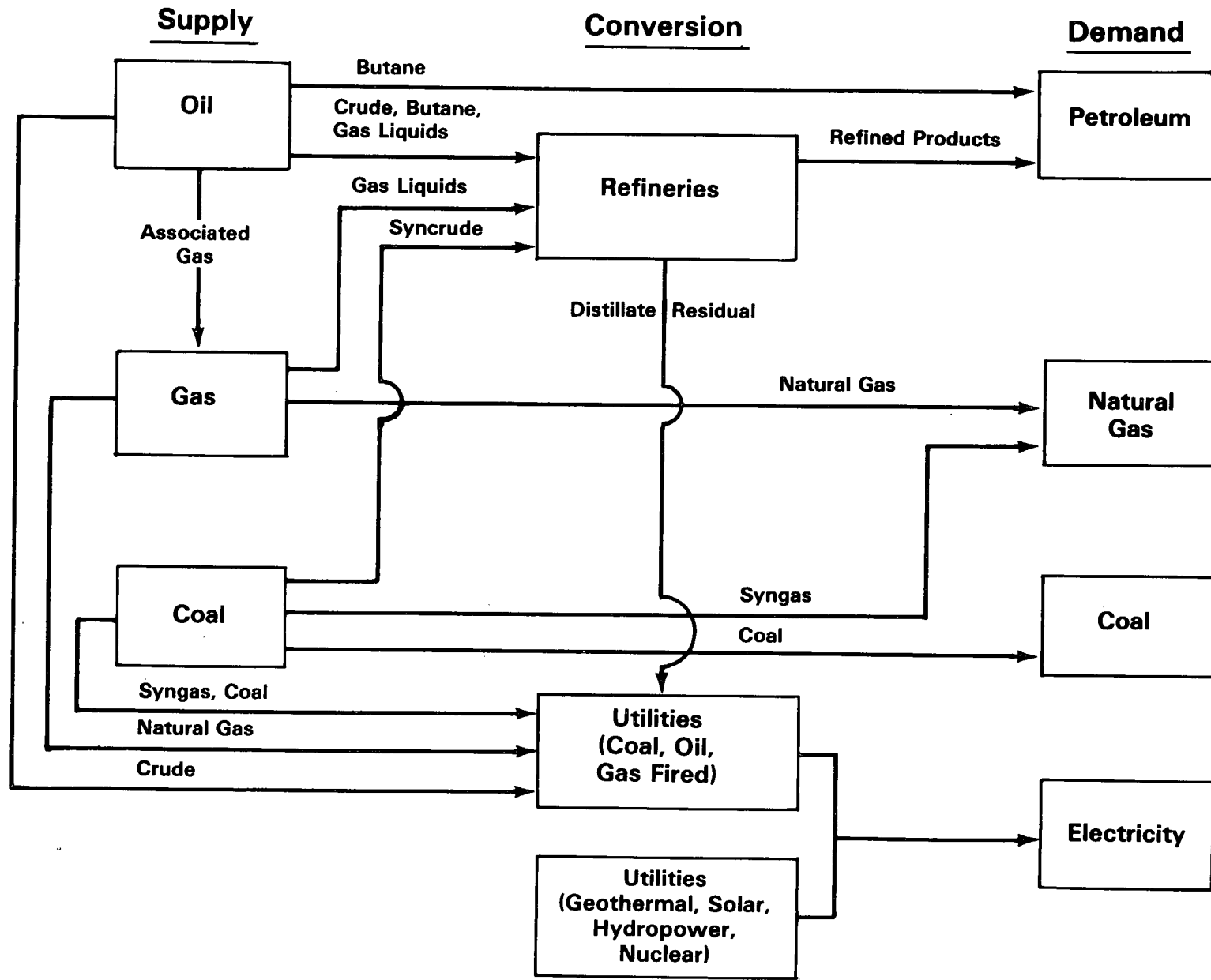

245

Figure A.1b Flow of Materials

scenarios are represented by sets of data that either select specific modeling structures (such as implementation of a new tax program) or change the value of certain model parameters to examine the sensitivity of results to specific data elements. Usually one scenario that contains the data and assumptions thought most likely to exist in the future is developed and used as a reference for analyzing alternative scenarios. These alternative scenarios permit the model to be used comparatively in order to observe the impact of changing the scenario assumptions.

## Components of IEES

### World Regions

In IEES the world is divided into 33 regions (see Figure A.1c). Each energy activity occurs in one or more of these regions. In the "other regions" category, Africa and Asia include the countries on those continents that do not otherwise appear in the table. The same method applies to Latin America. The Sino-Soviet region includes the Communist bloc countries in Europe and Asia as well as Cuba. The region consisting of the

Suez-Mediterranean and Lebanon pipelines is included only for the purposes of the transportation network.

## Energy Consumption

To develop estimates for future energy and fuel demands, assumptions are made about the historical relationships between energy consumption and the economic and demographic characteristics that have influenced consumption levels. Within IEES, two distinct demand models are used: one that provides estimates for OECD countries except the United States, and another that provides estimates for non-OECD countries, except for the Communist bloc countries, which are considered in IEES only to the extent of their net trade with the free world. Estimates for the United States are obtained from equilibrium solutions of the Midrange Energy Forecasting System (MEFS) in which MEFS was operated using scenario assumptions similar to those of IEES.

### OECD Model

The OECD model provides annual demand estimates for 23 fuels through 1995: coal, liquefied

#### U.S. (3)

U.S. East Coast  
U.S. Gulf Coast  
U.S. West Coast

#### Other OECD (excluding U.S.) (12)

Canada  
Japan  
Australia, New Zealand  
Norway, Sweden, Finland,  
Iceland  
United Kingdom, Ireland  
Belgium, Luxembourg,  
Netherlands, Denmark  
West Germany  
France  
Austria, Switzerland  
Spain, Portugal  
Italy  
Greece, Turkey

#### Transshipment Region (1)

Pipelines: Suez-Mediterranean  
Lebanon

#### OPEC (6)

Venezuela, Ecuador  
Libya, Algeria  
Nigeria, Gabon  
Indonesia  
Iran  
Persian Gulf (Iraq, Kuwait,  
Neutral Zone, Qatar,  
Saudi Arabia, United  
Arab Emirates)

#### LDC\* Oil Exporters (4)

Bolivia, Peru  
Egypt, Syria, Bahrain  
Angola, Congo, Zaire  
Asian Exporters

#### Other Regions (7)

Puerto Rico, Virgin Islands  
Mexico  
Other Caribbean  
Latin America  
Africa  
Asia  
Sino-Soviet

\*Lesser Developed Countries

Figure A.1c IEES Regions

gases, kerosene, residual fuel oil, electricity, natural gas, aviation gasoline, motor gasoline, diesel oil, jet fuel, coke, coke-oven gas, blast furnace gas, distillate fuel oil, briquettes, lignite, naphtha, petroleum coke, lubes, waxes, asphalt, and white spirits. These, as well as nonfuel categories, are presented in six user sectors (transportation, iron and steel industry, other manufacturing, residential-commercial-agriculture-government, nonenergy petroleum, and energy) for 22 OECD countries (Canada, Japan, Finland-Norway-Sweden, United Kingdom-Ireland, Belgium-the Netherlands-Luxembourg, Denmark, West Germany, France, Austria-Switzerland, Spain-Portugal, Italy, Greece-Turkey, and Australia-New Zealand). In all, 50 specific product-sector demand combinations are estimated. Quantity forecasts are accompanied by associated price forecasts, as well as by own-price, cross-price, and income elasticity estimates. Demand estimates are combined into 12 OECD country groups for use in IEES. The OECD energy demands are estimated by using multiple regression techniques. Estimated relationships are specified in terms of elasticities; that is, a percentage change in quantity demanded given a percentage change in price, or income, all other things being constant. All prices are expressed in 1975 constant dollars.

Relationships are derived by using data from EIA, OECD, the United Nations, and other sources covering the 1960-77 period. Included are historical data on fuel prices, foreign price deflators, foreign exchange rates, national income, gross domestic product, population, steel production, and car registrations. Forecasts of gross domestic product, population, steel production, and car registrations are also used. Price forecasts are determined by the model.

The OECD model structure considers substitution effects and output (budget) effects resulting from price and income changes. It also considers the influence of existing stocks on the speed with which demands change over time.

Three general model types are used in combination with the six user sectors mentioned previously. The iron and steel industry, other manufacturing, and residential-commercial sectors utilize a budget-substitution model. A total energy (Btu) budget is determined on the basis of energy prices, incomes, and past behavior. Then, given the Btu budget, specific fuels are chosen on the basis of relative prices and past behavior.

The same three user sectors, as well as the transportation and energy sectors, utilize a minor

fuels model when fuel substitution is not considered appropriate. Demands for these unique fuel uses are related to real income or to other relevant economic variables, such as production.

A major fuels model also determines unique fuel use demands, such as gasoline demand, in the transportation and nonenergy petroleum sectors. This model relates fuel demands to own-price, income, and previous consumption without allowances for fuel substitution. A "speed of adjustment" coefficient associated with the variable representing quantity consumed in the previous period provides an indication of the sensitivity of capital stock adjustments to income and price changes.

The minor fuels models use the ordinary least squares (OLS) regression technique; the major fuels and budget-substitution models use the random coefficient regression (RCR) technique. The OLS estimates are derived from individual country samples; RCR estimates are obtained from a pool of country samples. The RCR technique utilizes estimates that are assumed to vary randomly by country to determine a single, more precise estimate of the underlying relationship in question.

Short- and long-run price and income elasticities are derived by using these econometric techniques. Own- and cross-price elasticities describe the shape of the demand function at specific points in time for use in IEES. Nonprice savings in energy consumption that result from specified conservation programs are computed in the OECD model in terms of percentage differences from reference-case demands.

### Non-OECD Model

The non-OECD, or developing country, model utilizes econometric techniques developed by the Brookhaven National Laboratory. The model estimates per capita demand for fossil fuels as a function of fuel prices and per capita income. All values are expressed in 1975 constant dollars. Coefficients (elasticities) relating demands to income and prices are based on estimates developed by the World Bank. Total quantities are determined by multiplying the per capita results by estimates of population. Demands are estimated for oil, coal, and natural gas. Estimates of hydroelectric and nuclear generation are made outside the model and then added to the fossil fuels estimates to arrive at an estimate of total energy requirements.

For analysis purposes, countries are divided into six groups: industrialized, oil exporters (non-OPEC), balanced growth economies, primary (commodity) exporters, agricultural exporters, and other agricultural countries. Three sets of income coefficients are used to reflect different sensitivities in these countries: (1) industrial and oil exporting countries (non-OPEC), (2) balanced economies and primary exporter countries, and (3) agricultural countries. The coefficients are assigned on a country-by-country basis. Thus, results can be grouped into any configuration. For the OPEC countries, an income elasticity of unity for each fuel is assumed. One price elasticity, estimated by the World Bank, is used for all countries except members of OPEC, where zero elasticity is assumed.

The historical data (consumption, prices, gross domestic product, and population) and projections (gross domestic product and population) used in combination with the income and price coefficients are obtained primarily from the World Bank, the International Monetary Fund, and the United Nations. Price forecasts are determined by IEES. The model is calibrated to replicate base year (1975) consumption data.

### Resource Production

The most important factor affecting energy supply modeling is the character and extent of the depletable resource base. The data necessary to compute the fuel supply functions are supplied exogenously to IEES, although the functions themselves are computed within the model. This method is preferable to extrapolation of historical data or other statistical techniques in predicting raw material and product availability.

For coal, lignite, and natural gas, the method of determining the supply functions is to provide a starting price and quantity estimate, a price-supply elasticity, a price increment at which supply quantities will be calculated, and a minimum selling price. The data needed for these calculations are collected from a variety of sources and are derived from assessments of the investment required to increase supplies beyond current levels.

Crude oil production is handled somewhat differently. Three categories of producers are considered:

- Full production countries (mostly the smaller OPEC members), which will produce at their

maximum capacity whatever the world price of oil.

- Price-sensitive producers, which vary their production in accordance with market conditions.
- Swing producers (or marginal producers), which prorate their production to maintain the world oil price. These countries are the major OPEC producers.

Potential production rates and prices outside the United States are currently determined primarily on the basis of expert opinion and supply studies that are conducted outside the IEES framework.

### Electricity Generation

The electric utilities conversion model embedded in IEES simulates operation and planning behavior of electricity generation facilities. The model chooses the types and mix of capacity required to meet load demands, which vary both daily and seasonally. In so doing, IEES models the consumption of fuels (coal, residual, distillate, natural gas, and uranium) that are transported from producing and importing regions to utilities. It models conversion of fuels to electricity with appropriate energy losses and then models the release of that energy through the transmission and distribution network to satisfy demands for electricity. The key to modeling electric utilities is that they cannot inventory their product and must produce electricity on demand. This means that utilities must own some equipment that runs most of the time and some that runs only during peak demand periods. The demand levels for electricity during the year are represented by regional annual load duration curves of the form shown in Figure A.1d.

The types of generation equipment that can be used include nuclear power, conventional steam (using coal, natural gas, and residual oil), simple-cycle turbines, combined-cycle distillate turbines, and hydroelectric power. Each type of generation plant has its own cost and load factor characteristics.

In most cases, baseload generation is provided by either hydro, coal, residual oil, natural gas, or nuclear plants; intermediate load by hydro, coal, residual oil, or combined-cycle plants; and peak-load by hydro or turbines. In general, equipment

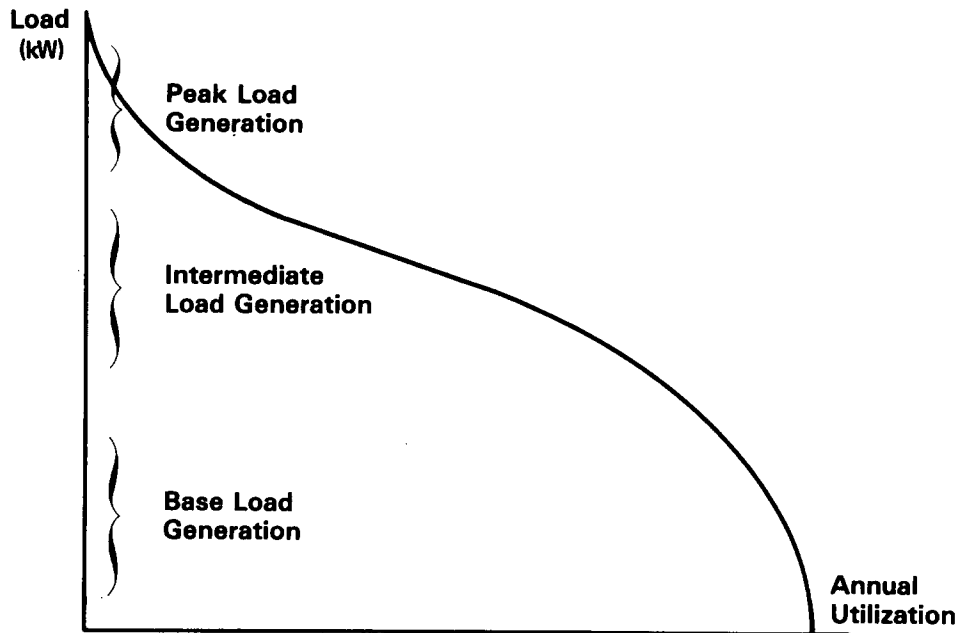

**Figure A.1d Typical Electric Utility Load Duration Curve Showing Relationship of Load to Peak Load as a Function of Time**

with higher capital costs and lower operating costs is best suited for baseload demand, whereas equipment with low capital costs but relatively high operating costs is better for satisfying peakload.

The IEES is provided with exogenous estimates of the capacity of each type of generating plant that will be commissioned in each of the OECD countries between now and the target years. The IEES assumes that these plants will be built first, and only makes investment decisions on the types of plant that are needed in addition to the committed plants.

Because the rates that electric utilities can charge are regulated, customers are charged the average cost of electricity based on actual costs of equipment rather than on replacement costs. Thus, IEES has consumers responding on the basis of average prices while utility investment decisions are made on the basis of margin production costs.

## Refineries

The simplified aggregate refinery planning model embedded in IEES represents the conversion of crude oils (both domestic and imported) to the six major refined products: gasoline, jet fuel, distillate fuel oil, residual fuel oil, liquefied petro-

leum gases, and other). Because crude oils processed by refineries differ in their physical and chemical characteristics, each type must be processed differently, with processing costs varying slightly among crudes and each operating mode producing a different mix of products. The IEES refineries model differentiates crude oils by their specific gravity and sulfur content and can distinguish approximately 50 different crude oil types.

The refineries model captures the characteristics of the world's existing refinery capacity by calibrating and adjusting the model off-line to simulate recent performance of the industry. Provision is also made for modeling expansion of the refinery industry by providing a spectrum of choices for construction of new capacity. As with utilities, the inclusion of new capacity requires that capital expenditures be made. In IEES, these costs are reflected by including annualized capital charges in the costs of operating new refinery modes.

Consistent with the overall IEES approach, the refineries simulation selects specific crude types for each refinery region, chooses specific operating modes, specifies necessary types of capacity for expansion, and produces and transports refined products to consumers in a way that minimizes the refiner's costs.

## Synthetics

Three major conversions of fossil fuels to alternative hydrocarbon forms are modeled as part of the IEES conversion model:

- Metallurgical coal is used in blast furnaces to produce steel, and produces blast furnace gas and coke as a byproduct.
- Steam coal is used in gasworks and coke ovens to produce blast-furnace gas and coke.
- Lignite is made into briquettes.

The model assumes that unlimited quantities of these conversions can take place at constant costs.

## Transportation

The transportation model in IEES simulates interregional movements of energy resources among the 33 IEES regions. Although intraregional movements are not considered explicitly, estimates of their costs are included in the product and refinery costs.

A total of 11 material-transport modes are considered: coal movements by rail, barge, and bulk carrier; natural gas movements by pipeline and liquefied natural gas (LNG) carrier; crude oil movements by medium and large tanker, very large crude carrier (VLCC), and pipeline; and petroleum product movements by product tanker and pipeline. For each of these transport modes, possible route networks, shipping costs, maximum numbers of transport vehicles, and maximum quantities of energy products transported daily are modeled. The transshipment of crude oil between the Suez-Mediterranean and Lebanon pipelines and tankers carrying the crude oil to European ports is also modeled.

The material-transport modes involve several classes of shipping differentiated by size, category, and type of cargo handled. Several sizes of oil tankers are specified to reflect the differing economies of the various ships and to represent physical restrictions on canal passage and port access. For instance, VLCC's require "superports" to unload their cargo and can transit the Suez Canal only when sailing in ballast. A feature of the IEES transportation model is the dynamic adjustment of shipping rates as a function of the price of bunker fuel. The transportation costs of each route are adjusted on the basis of the price and usage of bunker fuel for each type of ship. These adjust-

ments are a function of both the routing and the efficiency of the ships.

## United States Representation

The representation of the United States used most frequently in IEES utilizes a schedule of U.S. oil and natural gas imports and coal exports from the Midrange Energy Forecasting System (MEFS). This incorporates the MEFS levels of total U.S. imports and exports into IEES for the appropriate scenario. The United States is divided into three regions in this representation primarily to model transportation.

## World Oil Prices

The Oil Market Simulation (OMS) model is the primary system used by the EIA for forecasting midterm world oil prices. The model is run iteratively with the IEES in order to equilibrate world energy supply and demand at a forecasted world oil price. The OMS is a reduced-form representation of more detailed energy and macroeconomic models used by the EIA. It is an econometric model that is calibrated to the Midterm Energy Forecasting System and the Data Resources, Inc. (DRI) macroeconomic model for U.S. economic response. For non-U.S. economic response, OMS is calibrated to the IEES and the Wharton Econometric Forecasting Associates, Inc./SRI International (WEFA/SRI) world macroeconomic model.

The estimation of world oil prices depends upon:

- A set of world oil demands and non-OPEC oil supplies estimated at some reference price path
- The responsiveness of these demands and supplies to a change in the world oil price
- The impact upon economic growth (feedback effect) resulting from a change in the world oil price
- An assumption regarding OPEC pricing behavior that defines a relationship between OPEC price changes and OPEC capacity utilization
- A set of maximum sustainable OPEC production capacities estimated over the forecast period.

The rate of OPEC price increase or decrease is specified as an exponential function of the percent



utilization of OPEC maximum sustainable production capacity. This function is of the form  $y = a + b/(1-x)$ , where the constants  $a$  and  $b$  were calibrated by fitting a least squares curve through historical data points. The relationship was derived from an analysis of postembargo OPEC price changes (see Figure A.1e). The estimates of maximum sustainable OPEC production capacity are based upon country-by-country analyses provided by the DOE Office of International Affairs.

The OMS model solution algorithm is illustrated in Figure A.1f. The model output includes a forecasted price path and its corresponding world oil supply-demand balance. A technical description of the OMS methodology can be found in the EIA Analysis Report, *A Sensitivity Analysis of World Oil Prices AR/IA/79-47*. Complete documentation of the OMS model is forthcoming in late fiscal year 1980.

## Solution Procedure

The IEES methodology is designed to balance supply, conservation, and demand forecasts by computing equilibrium quantities in a partially regulated market.

Underlying the procedure is the assumption that consumers and suppliers act in their own self-interest, subject to the constraints imposed by government policies. It is assumed that consumers seek to maximize their benefits and that producers maximize profits. Under this assumption, demands will increase as prices decrease and supplies will increase as prices increase. Accordingly, the supply and demand functions are of the general form depicted in Figure A.1g, and market equilibrium exists where the supply and demand curves intersect. This occurs in IEES when fuels are purchased by consumers in a cost-conscious manner, substi-

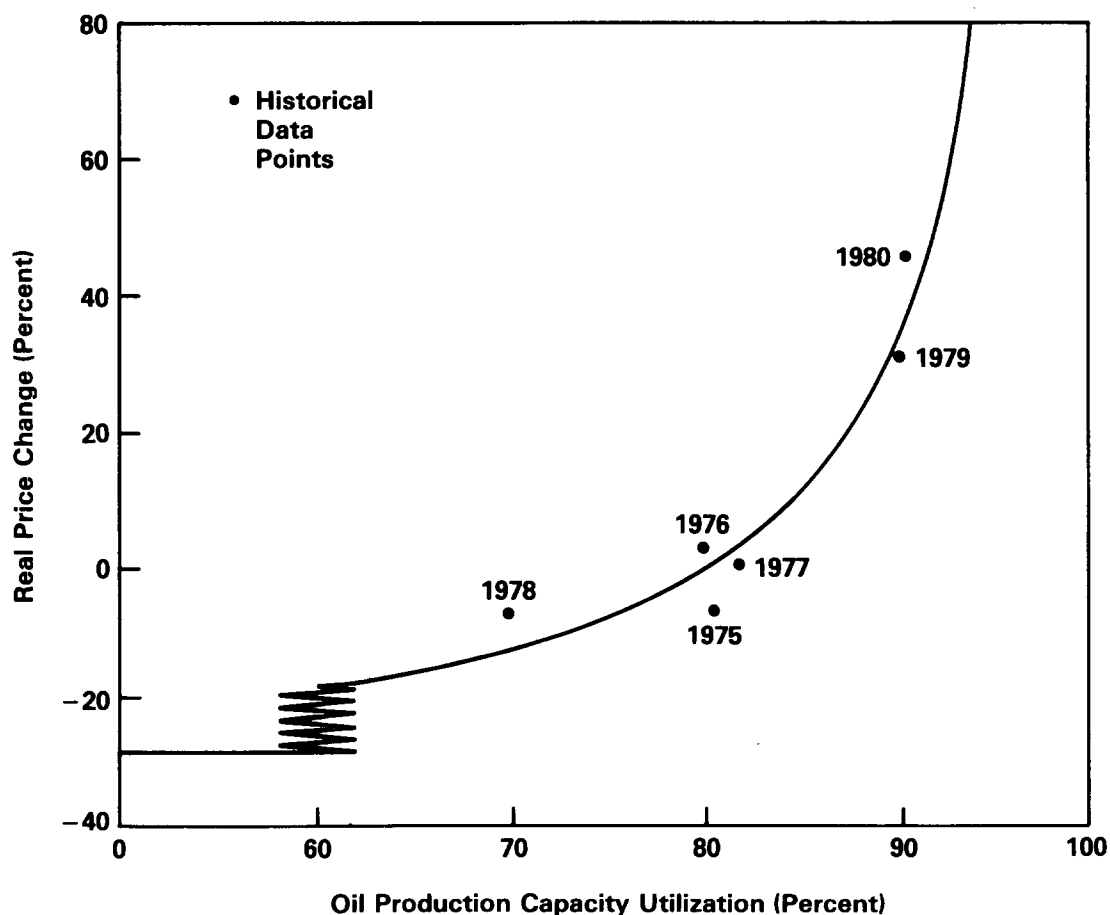

Figure A.1e OPEC Pricing Behavior

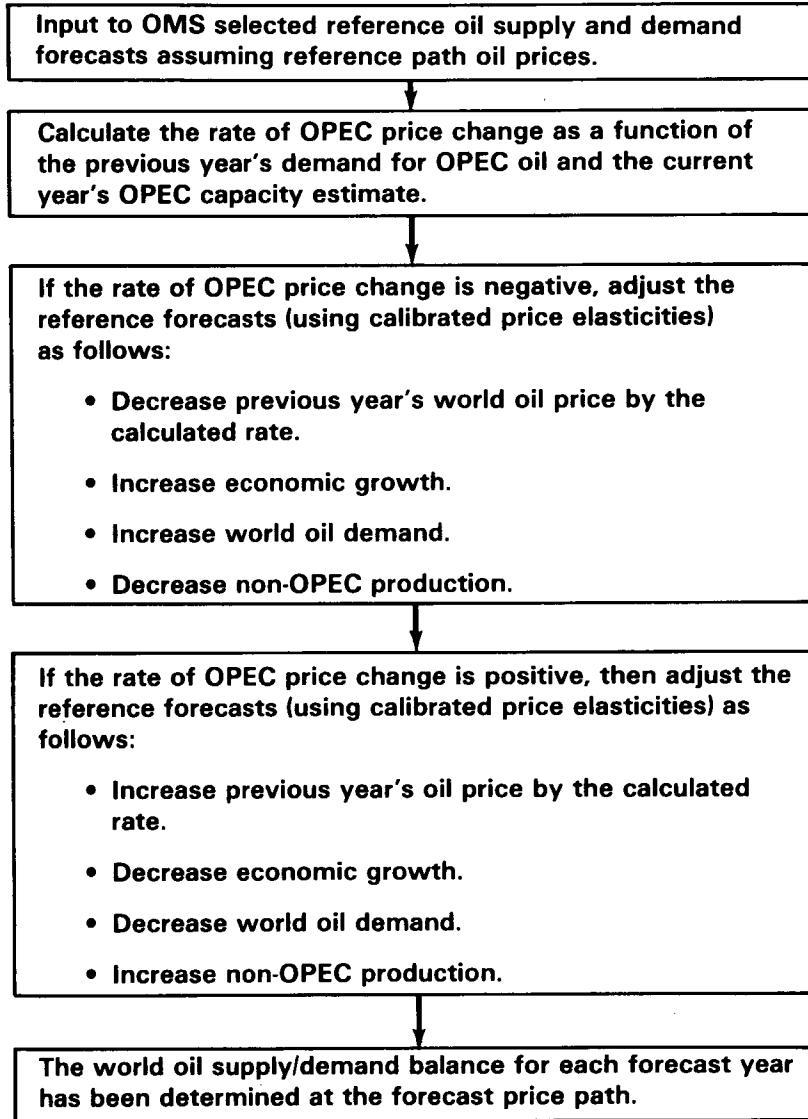

Figure A.1f OMS Pricing Algorithm

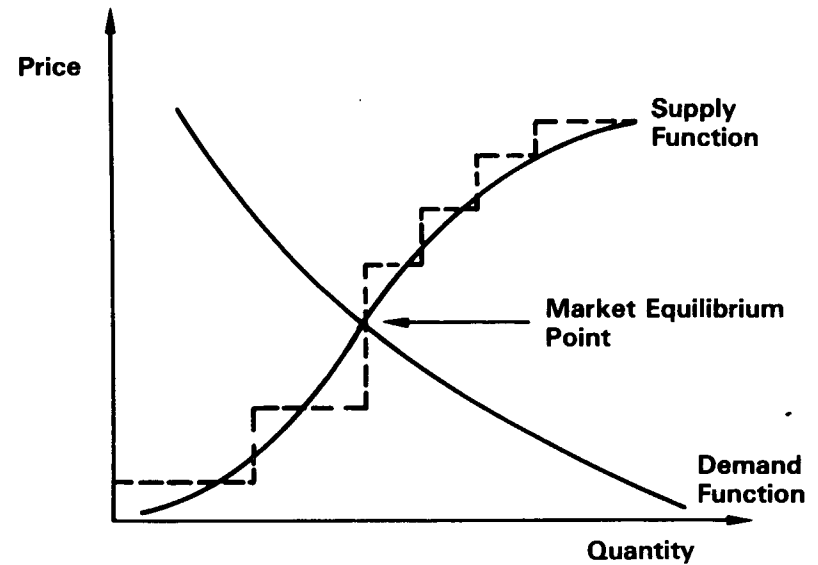

Figure A.1g Typical Supply and Demand Curves

tuting one fuel for another on the basis of relative price changes and the tendency of industry to maximize its return across the international energy market. Because perfect market conditions do not occur in the real world, the IEES representation is clearly an approximation to reality. An equilibrium determined by IEES represents a solution to the overall problem of energy supply and demand in a partially regulated market. The IEES is not solely a model of price behavior, because the energy system has restrictions on resource availability and other constraining regulatory assumptions imposed upon it.

To obtain a market equilibrium point, supply must equal demand. The IEES does this by formulating a linear program that optimizes consumers' and producers' self-interests and forces supplies to equal demands. To solve the problem with linear programming techniques, step-like approximations to the supply and demand curves are generated (see Figure A.1g). The step-function approximation to the demand curve is obtained by using the estimates from the demand models; the integrated supply network represents the supply approximation. By incorporating the step functions and initial levels of demand estimates into the linear program and optimizing on prices, the levels of demand and energy industry activity are obtained. This solution to the linear program is not automatically in equilibrium; the linear program can only provide directly for fuel substitution effects in the electric utilities sector. To handle this problem, several iterations of the solution procedure are performed, and a revised set of demand estimates are used on each iteration. These demand estimates are calculated with the use of a continuous demand curve, which is based on the initial prices and quantities, and the own- and cross-price elasticities obtained from the demand models.

When, on a particular solution of the linear program, the set of prices and associated quantities are within specified tolerance limits of the previous solution, the model has converged to the equilibrium solution. If an equilibrium is not obtained, new levels of product demand in each region are calculated from the previous solution, and the cross-price elasticity effects of fuel products are taken into account. The new levels of product demand and a new demand approximation are entered into the linear program, which is solved again. The process is continued until an equilibrium solution is obtained. Several iterations

may be required. Calculations are also performed between various solutions of the linear program that force the model to accept an average input price for OPEC crude oil received on the east coast of the United States. This price was determined exogenously to the IEES system with the use of the Oil Market Simulation (OMS) model.

## A.2 THE SHORT-TERM INTEGRATED FORECASTING SYSTEM (STIFS)

### Introduction

The Energy Information Administration's Short-Term Integrated Forecasting System (STIFS) is a comprehensive, automated software system and data base that simulates the network of national energy supplies, inventories, imports, conversion processes, and demands. Its purpose is to produce automated monthly, quarterly, and annual forecasts of integrated energy supply-demand balances, including stock changes over the short term (e.g., 12 to 36 months). Figure A.2a represents the energy accounting structure of the STIFS, portrayed as a network. The primary energy types forecasted correspond to the historical energy data published in EIA's *Monthly Energy Review* (MER). Those data include national production, supply, demand, stocks, and surplus-shortage for motor gasoline, distillate fuel oil, residual fuel oil, jet fuel, natural gas, coal, and electricity. Regional forecasts are not currently provided.

The STIFS consists primarily of two processes. First, a set of computations known as a "closing routine" operates in conjunction with the historical data base to balance historical energy supplies and demands, isolating data discrepancies in the process. Second, more than 100 network flow-variables are forecasted by means of statistical and econometric procedures, while another closing routine balances forecasted energy accounts and isolates implied shortages or surpluses by energy type. Figure A.2b illustrates this process for the case of motor gasoline production, imports, stocks, and deliveries.

The STIFS also incorporates a capability to simulate supply crises for specific fuel types. This is done by altering various system inputs. For example, the energy impact of embargoes or

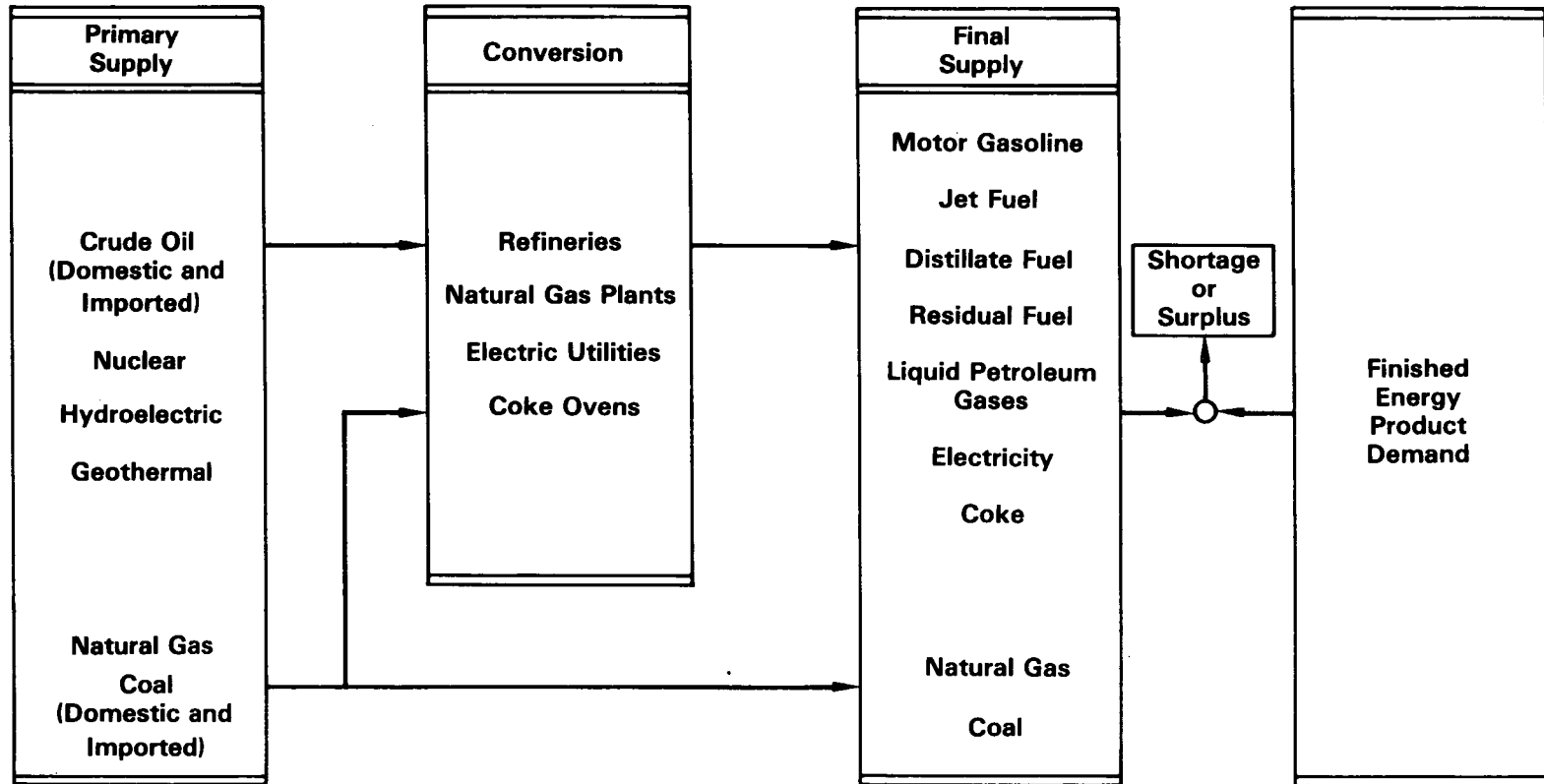

Figure A.2a STIFS Reference Network (Summary Version)

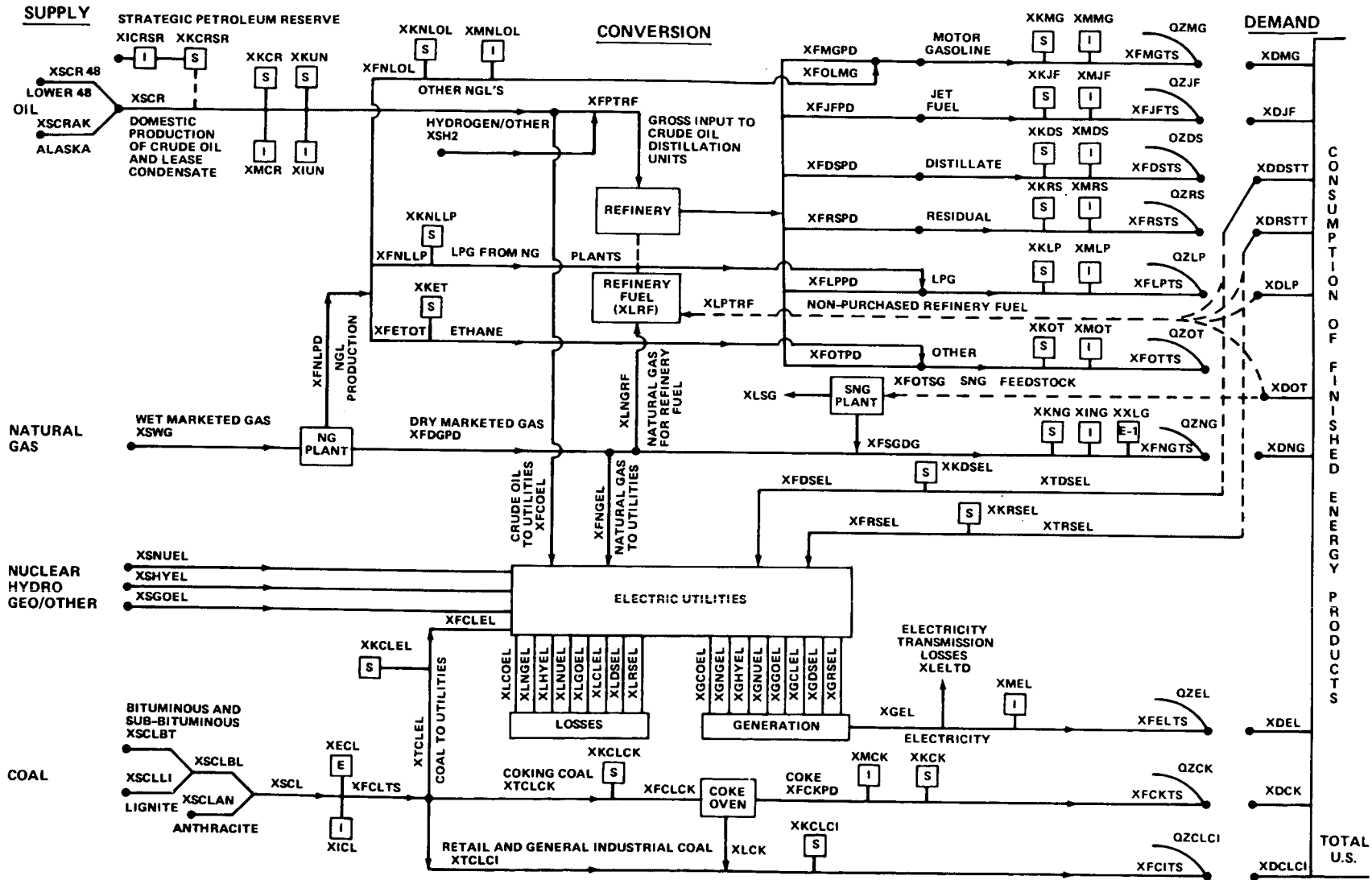

Figure A.2a Interim Short-Term Integrated Forecasting System Reference Network and Variable Names (Detailed Version)

political upheavals can be simulated by imposing a limit on the level of total petroleum imports allowed. Nuclear powerplant outages can be reflected by lower forecasts of nuclear power supply. An extremely harsh winter is reflected by increasing the number of heating degree-days input to various submodels of fuel-specific demand. In these and other ways, a variety of crisis scenarios can be simulated and measures for relieving these crises can be analyzed.

The software system consists of five elements: (1) several exogenous models for supply and demand of major fuels, (2) macroeconomic impacts, (3) data base maintenance software, (4) the integration closure routines, and (5) a comprehensive set of report writers and graphic display software. Figure A.2c illustrates the system from the standpoint of software. The numbers in the diagrams represent the approximate number of card images in each program component.

### **Historical Data Base and Closure Routine**

The historical data base is used as an input to the closing routine and provides the basis for many of the STIFS forecasts. The data base provides information on all significant elements within the Nation's energy network on a monthly basis. The historical closing routine is a computerized double-entry energy accounting system that calculates total supplies for each fuel in quadrillion Btu, compares total supplies with demands, and calculates a balancing or discrepancy item. Where possible, internally derived values are cross-checked with reported values to identify possible data errors.

#### **Electric Utilities**

The data closure routine begins by checking data for the electric utilities sector. A problem arises because data on utility consumption of petroleum are not reported in the form required for the network and must, therefore, be converted. Utility receipts of fuels are covered by a reporting system with a smaller reporting universe than the generation and fuel consumption data series. Until recently, consumption of petroleum has not been differentiated among No. 2 distillate, heavier oils, and crude oil. Instead, petroleum used for electricity generation has been reported for "steam" plants and for "nonsteam" plants (primarily gas turbines and internal combustion engines).

The petroleum receipts estimates for the STIFS network are derived from the reported data by assuming that 96 percent of all petroleum used in steam plants is residual fuel oil, 3.5 percent is distillate fuel oil, and 0.5 percent is crude oil. Also, it is assumed that 98 percent of the petroleum used in other nonsteam types of generating plants is distillate fuel oil and 2 percent is residual fuel oil.

In applying these percentages to the reported data on utility consumption, stocks and generation attributable to petroleum are broken out into distillate, residual, and crude oil. All values are then converted to quadrillion Btu. Finally, implied heat rates (fuel consumed per kilowatt-hour of electricity generated) are calculated for each fuel and then compared with reported heat rates as a cross-check.

The procedure for calculating coal and natural gas flows to utilities is more straightforward, because reported data correspond more closely to the STIFS network definitions. Total shipments of coal to utilities is derived from coal consumed at utilities and net utility coal stock change. Because the market share of western subbituminous coal has been increasing, the national average thermal content of coal has been declining. Values for natural gas used by utilities are reported directly to the Department of Energy. Reported values for coal and natural gas consumed by utilities are converted to quadrillion Btu, and cross-checked by multiplying the reported values of generation (in kilowatt-hours) from coal and natural gas by the reported heat rates of coal and gas plants. Finally, conversion losses are calculated as the difference between the quadrillion Btu of coal and natural gas consumed by utilities and the quadrillion Btu of electricity generated from those fuels.

Total flows of hydroelectric power, nuclear power, and geothermal energy to the electric utility sector are calculated in quadrillion Btu as the product of electricity generated from each source and the appropriate heat rate. Losses are calculated as the difference between the total supply of the fuel in quadrillion Btu and the equivalent quadrillion Btu of electricity generated by nuclear, hydroelectric, or geothermal energy.

The components of electrical generation are summed, and this value of total generation is then compared with the reported generation as a cross-check. Transmission and distribution losses are estimated as a fixed percentage of total generation. The total electricity "available for sale" is then calculated as the sum of total generation and net imports of electricity, less the transmission and

## ① Historic Closure

August 1979 Motor Gasoline:

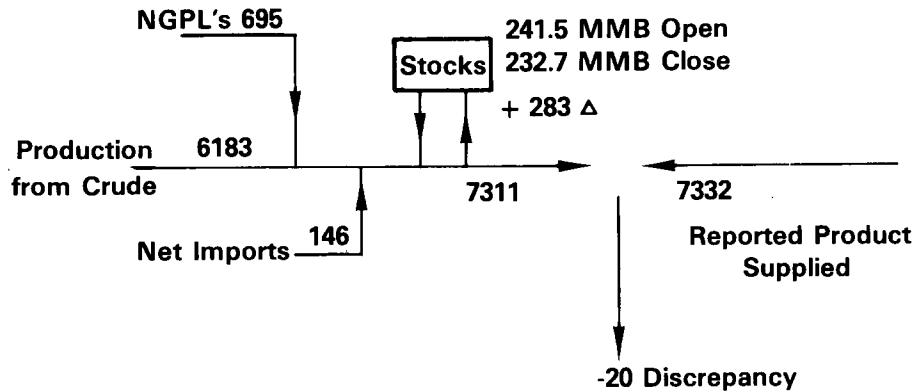

## ② Forecasting

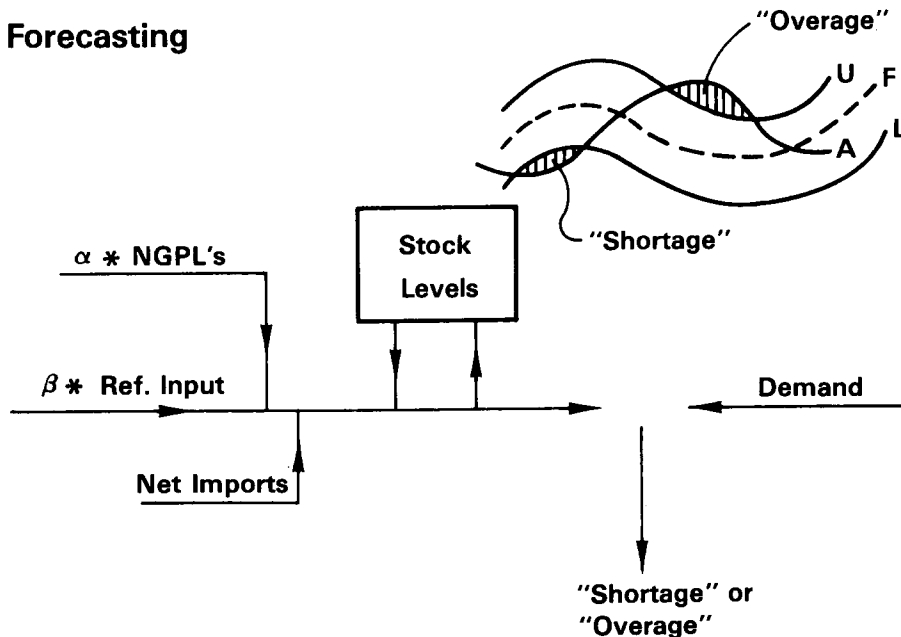

Figure A.2b STIFS Functions

distribution loss. Finally, total electric utility sector discrepancy is calculated as the difference between reported electricity sales and the amount of electricity "available for sale" as calculated by the procedure described above.

### Oil and Refining

Following the checks of electric utility data, STIFS proceeds to the oil and refining data (crude oil, natural gas liquids, and refined petroleum products). Natural gas liquids extracted from

"wet" natural gas at gas processing plants are split into three streams: ethane, which is added to the supply of "other" petroleum products downstream from the refinery; liquefied petroleum gases (LPG), which are added to downstream supplies of LPG's; and motor gasoline blendstock, 35 percent of which is input to distillation units at the refinery and the remainder blended into motor gasoline downstream from the primary distillation units. In accordance with past practice, all of the last category is considered to end up in the gasoline pool. It is split up mainly to attribute a

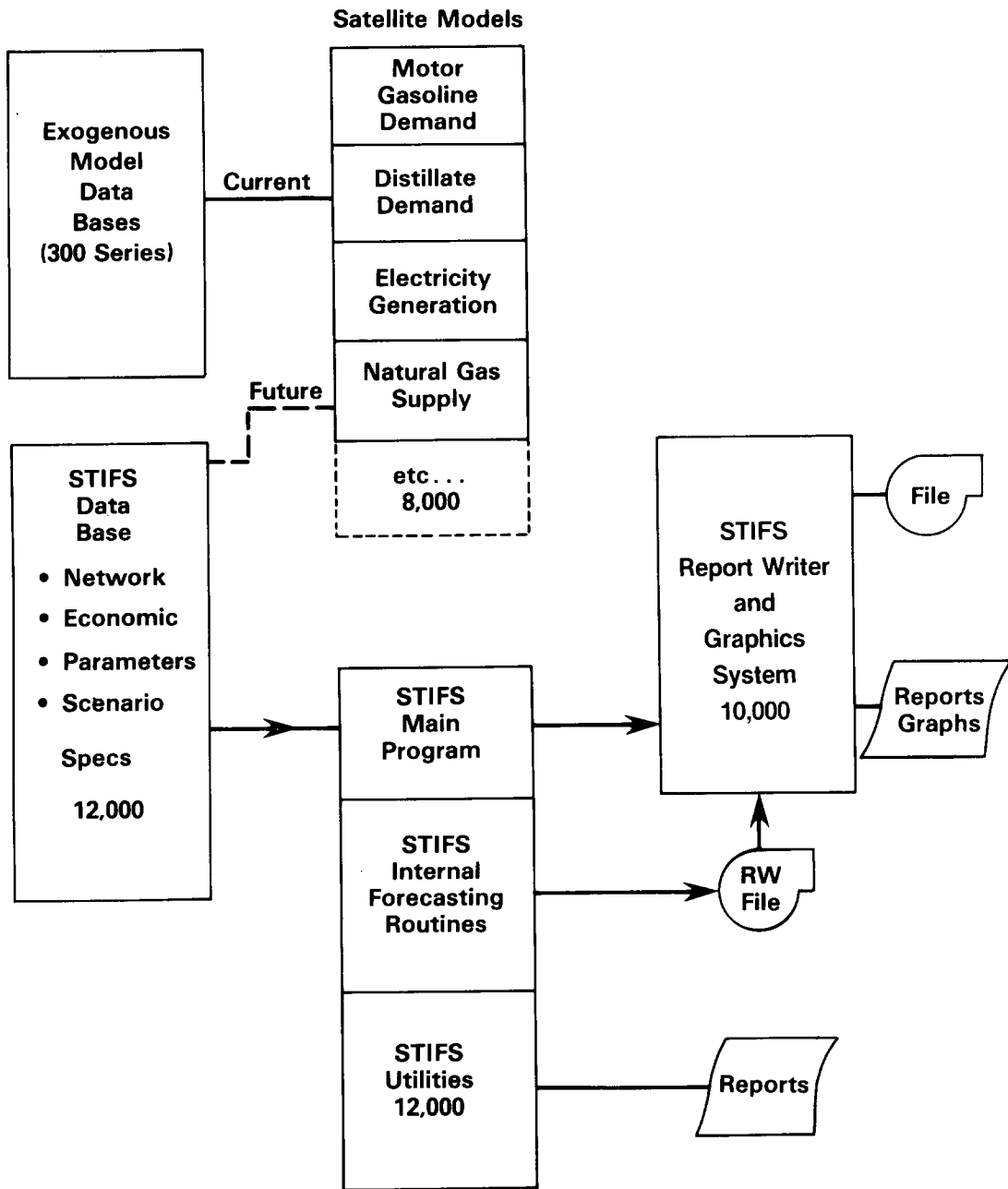

Figure A.2c STIFS Software—May 1980



portion of the quantity to primary distillation feedstock for use in capacity utilization and limitation analyses.

Total refinery input is calculated in both barrels per day and quadrillion Btu and compared with reported data on total refinery input as a cross-check. In this calculation for total refinery input, allowance must be made for definitional differences because the STIFS data base excludes "unaccounted-for crude oil," transfers, and losses. As another check, refinery outputs are totalled and compared with total input. Total supplies of finished petroleum products are calculated in barrels and quadrillion Btu as the sum of refinery output, stock change, and net imports, while calculated thermal contents are compared with the thermal contents that serve as STIFS' parameter values. Total supplies are compared with total demands, and balances are then calculated. Balancing items are checked to see that they do not exceed a user-specified tolerance (about 1 percent) of the final demand.

### **Natural Gas**

Natural gas supply is calculated in both quadrillion Btu and cubic feet as the sum of dry gas production, synthetic natural gas (SNG) production, net imports, and stock drawdown, less natural gas used by refineries and electric utilities. The discrepancy term is calculated as the difference between that total supply and reported demand. The calculation is then checked to see that it is within a prespecified tolerance (currently 1.5 percent) of reported demand.

### **Coal and Coke**

Coal supplies are split into three streams: electric utility coal, coking coal for metallurgical purposes, and coal for all other uses.

Coke-oven losses (approximately 32 percent by weights) are calculated in tons as the difference between coking coal consumption and coke production, with the ratio of coke production to coking coal consumption compared with the efficiency factor for coke ovens as a cross-check. Total coke supply is then calculated as the sum of coke production, net imports, and stock drawdown, with a discrepancy term calculated and checked against the final demand.

Total supply of retail and general industrial coal is calculated from total shipments and stock drawdown in tons and quadrillion Btu. The ther-

mal content is calculated as the ratio of total supply measured in quadrillion Btu to total supply measured in tons; this ratio is compared with the thermal content in the STIFS data base. The discrepancy term is then calculated and checked against the final demand. The overall coal balance is calculated as the difference between total coal supply (utility coal, coking coal, and retail-industrial coal) and reported coal demand; it is then checked against demand.

## **STIFS Forecasting Procedure**

The forecasting system represents future energy flows under a variety of scenarios, simulating energy supply-demand responses to such circumstances as alternative levels of petroleum imports, a coal strike, or droughts. The present forecasting system is primarily oriented to petroleum imports scenarios; future development of the system will allow a wider range of scenario variations in modeling.

Operation of the simulation programs of the STIFS system can be viewed conceptually as having five steps.

1. Network variables for which historical data exist have been initialized and the historical closure routine has been executed; i.e., all remaining network variables have been computed, discrepancies at network nodes have been noted, and corrections or adjustments to data base values have been made as necessary. The historical closure guarantees that the historical version of the network is internally consistent and sufficiently accurate to forecast future series.
2. Network parameters and independent variables to be input to peripheral econometric models are preset and based on the scenario to be simulated by the system. The Phase I version of STIFS permits the user to specify alternative macroeconomic scenarios (e.g., alternative prices, incomes, etc.), constrained imports scenarios, stock level scenarios, and certain electric utility supply interruption scenarios.
3. The major network variables are forecast internally or externally, as appropriate. In the Phase I system, most scenario-specific variables are forecast externally, whereas most nonscenario-specific variables are forecast internally by using the STIFS data base and simple time-series forecasting techniques. Ex-

tended forecasts are generated by special peripheral models, industry estimates, or special analyses.

4. The forecast closure is executed, i.e., forecast period values are computed for all remaining network variables as a function of those variables already forecast. All variables are converted from input units to standard STIFS physical units and to quadrillion Btu. Discrepancies between supplies and demands are recorded as surpluses or shortages, as appropriate.
5. Inputs to and outputs from the above computations are filed for display by a variety of STIFS report-writing and graphic output routines.

### Internal Forecasts

Of the approximately 120 major variables in the network, about 75 to 80 of these variables are forecast internally by the STIFS integration model. These internal forecasts are generated primarily from historical series in the STIFS data base and may be used in one of three ways: (1) as the final forecast series for network closure in the case of a nonscenario-specific forecast variable, or a "driving" variable for which a good external forecasting model is not available or has been shown to be unsatisfactory; (2) as a means of checking the reasonableness of the value of a variable that has been computed as a function of other forecast variables; or (3) as a means to fill in "holes" in a data series for which there are no near-term data, but for which a forecast is to be made. As mentioned previously, most stock levels throughout the network are in the first category. For most major network variables, an internal forecast is generated simply as a fallback forecast and immediately overlaid by an external model forecast.

For each variable forecast internally, simple curve-fitting procedures were chosen to generate a forecast series. While the STIFS internal forecasting subroutine currently uses only two "exogenous" variables (heating and cooling degree-days), it is being expanded so that it will be able to support more elaborate econometric equations.

### Externally Forecast Variables

The simulation of a given scenario may be decomposed into six areas: import targets, fuel shares of electricity generation, petroleum refin-

ery operations, natural gas, coal, and energy network balancing. The simulation begins with a user-input preliminary estimate of world supplies of crude oil and refined products during the forecast period. It is assumed that no "shortages" will occur for petroleum products if exportable oil is available, except for cases in which special refining may be necessary (e.g., unleaded motor gasoline or low-sulfur residual fuel oil). If initial import limits produce surplus stocks of crude oil, the import limits are lowered and the simulation is then rerun. If a surplus of residual fuel oil is foreseen, a preselected fraction is taken from imports; the rest of the oversupply is corrected by adjusting domestic refinery yields. If concurrent shortages and surpluses occur in two products, then refinery product yields are automatically adjusted to redistribute the product. In an unconstrained import environment, stocks may build at any rate; the final stock level for petroleum is arrived at by case study, judgment, and industry projections and then input as a scenario assumption.

Major network variables, including primary energy sources and final demands, are forecast externally as a function of numerous exogenous variables. Those variables include various price-related variables, seasonal dummy variables, heating and cooling degree-days, time, population variables, income variables, and vehicle-travel variables. By projecting these exogenous, independent variables (upon which the major network variables depend) under varying assumptions, a variety of scenarios dealing with future economic conditions, weather behavior, and other similar subjects may be formulated. Accordingly, STIFS may be solved under alternative assumptions to anticipate fuel requirements up to 3 years in the future.

### Electric Utilities

Generation estimates of new and existing coal and nuclear-fired steam-electric plants are made off-line by using data on startups from various sources, as well as estimates of startup year capacity-utilization factors. Hydroelectric power is currently forecast by using simple time-series analysis. Amounts of residual and distillate fuel oil, crude oil, and natural gas used by electric utilities are then calculated econometrically as a function of relative prices and generation efficiencies for these fuels. Amounts of distillate and residual fuel oil shipped to the electric utility

sector are then calculated from both the above amounts and the internally forecast change in utility stocks for these two fuels (the difference between successive stock targets) for the period. Nonutility demand for the two fuels is forecast with econometric models. Total nationwide demands for distillate and residual fuel oil are the sum of utility shipments and nonutility demand.

Several checks on the above computations are made to verify that the fuel-flows to the electric utility sector are within a reasonable range in relation to historical values. Electricity generation losses are computed for each of the five utility fossil fuels as the difference between the calculated amount of fuel used and forecast generation share.

Required supplies of coal, nuclear, hydroelectric, and geothermal fuels are calculated from forecast amounts of generation by these fuels, and each fuel's accepted heat rates and thermal content. In the case of coal, nationwide thermal content is forecast as a time series based on estimates of the penetration rate of western subbituminous coal, which has been lowering the national thermal content of steam coal in recent years. Generation losses are calculated in the same manner as fossil fuels. Several checks are also made to verify that the calculated quantities for the utility sector are reasonable. Among these are total electricity transmission and distribution losses, total utility conversion losses, total conversion efficiency (quadrillion Btu in-quadrillion Btu out), and average heat rate of fossil fuel.

## Oil and Refining

Refinery capacity forecasts for primary distillation units are based on DOE estimates of future growth in capacity. Target values of refinery utilization are forecast as a function of the historical utilization data. Stocks of natural gas plant liquids (NGPL) used at refineries are set at their internally generated forecast targets. Stocks of liquefied petroleum gases (LPG) at refineries are calculated to be the total stocks of LPG's (forecast from historical stock data) less the stocks of LPG's at natural gas processing plants (also forecast). Strategic Petroleum Reserve (SPR) stocks are changed from the stock level of the previous forecast period by using a scenario-specified fill rate. Forecast values of ethane and LPG's produced at natural gas processing plants are computed by multiplying the appropriate fractional pa-

rameters by the forecast value of the total NGPL production. The forecast value of NGPL production that is considered to be shipped to refineries is set equal to the amount of total NGPL production that remains. The total consumption of NGPL's at refineries is calculated as the amount of production from NGPL's that is shipped to refineries less the stock change from the previous forecast period plus imports.

For unconstrained import scenarios, the forecast simulation looks ahead and calculates, for each quarter of the year, the indicated imports that are needed to balance supply and demand, thus keeping stocks at their target levels. Imports are shared among fuels according to historical fractions and specified to months according to historical seasonal patterns.

Gross input to distillation units is calculated as a function of the forecast supply, imports, and stock change in crude oils, unfinished oils, and NGPL's; this calculation is conditioned by whether or not crude stocks can be maintained within an acceptable range. First, the change in crude stocks that is implied by forecast values for the following is calculated: crude supply, supply of hydrogen and other hydrocarbons, imports of crude and unfinished oils, target stock change of unfinished oils, flows of crude to utilities, flows of NGPL's to refineries, refinery capacity, and refinery utilization. If the resulting crude stock level is above the upper end of a specified range, then imports must be reduced. This is done by reducing target imports of crude and unfinished oils, in proportion to their relative amounts, until the implied crude stock level falls within the accepted range. If the crude stock level begins to fall below the lower end of its accepted range, then refinery input must be reduced. Gross input to distillation units is diminished to where crude stocks follow the lower boundary of the accepted range; the (lower) refinery utilization rate implied by this level of input is then recomputed. If the crude stock level is within the accepted range, the gross input to distillation units is simply set equal to the product of forecast utilization and capacity levels.

Motor gasoline production is defined as a pre-specified percentage of NGPL's blended plus refinery production. The amount of production for the remaining five refined products (distillate fuel oil, residual fuel oil, jet fuel, LPG's, and "other" products) is defined as the product of a similarly forecast yield fraction and the adjusted input of crude oil plus unfinished oil reruns.

A surplus or shortage for each refined product is calculated as a function of forecast domestic production, imports, and demand for the product; this surplus-shortage function is conditioned by the final stock change that is implied by the values of the refined product falling within a given stock range. Should concurrent shortages and surpluses of separate products occur in a given time period, the simulation will attempt to alleviate this condition by shifting yields up to a prespecified maximum.

The remainder of the forecast closure for the oil and refining subnetwork involves the development of cross-checks, the conversion of all variables from standard units to quadrillion Btu, and the computation of various aggregate quantities for reporting purposes. Among the quantities checked for reasonableness are the thermal content of refinery input and the volume of refinery output.

### **Natural Gas**

The natural gas subnetwork deals primarily with dry gas, because the three components of NGPL's—ethane, LPG's (butane, propane, and isobutane), and "other NGPL's"—are dealt with in the oil and refining subnetwork.

Supply of dry gas production is forecast externally. The final level of consumption implied by the forecast values is calculated from the following: dry gas production, natural gas used as refinery fuel, natural gas required by utilities, SNG production, target stock levels, imports of dry gas, and exports of liquefied natural gas (LNG). No surplus-shortage is allowed.

If scenarios were constructed in which severe natural gas shortages might result, the subnetwork would be restructured to adjust stock levels as a function of supply and demand. However, natural gas has been curtailed to certain users during cold weather, therefore "demand" must be implied from available supplies.

### **Coal and Coke**

Coal flows to four major uses in the STIFS network: coal exports, coal consumed by electric utilities, coking coal for metallurgical purposes, and coal for all other retail and industrial uses. Coal used by utilities is calculated in the utility subnetwork closure. Only the coking and retail-industrial coal portions of the forecast sub-

network are handled in the final stage of the simulation.

The amount of coal charged to coke ovens is forecast from historical values. Coke production is set equal to coke-oven consumption of coal, multiplied by a fraction reflecting losses (approximately 32 percent by tonnage). The amount of coal flowing to coke ovens is set equal to consumption by coke ovens plus the target increase in coking coal stocks. Tonnage of coke-oven losses is then computed. Next, final coke supply is calculated as the sum of computed coke production, target coke imports, and drawdown of coke stocks as computed from the beginning and the ending stocks. Demand for coke is set equal to final supply, i.e., no shortage of coke is allowed.

The key driving variable for the retail and industrial portion of the subnetwork is final demand. Retail and industrial coal production is set equal to the forecast demand, plus target increase in retail and industrial final stocks because shortages are not allowed. The total coal supply is defined as the sum of the utility supply, coking coal supply, and retail and industrial coal supply. Total coal production is defined as the total computed supply, plus the forecast exports, less the forecast imports. At the present time, the anthracite, bituminous, subbituminous, and lignite categories are not distinguished in the network.

### **Forecast Closure**

In regard to the forecast period as well as the historical period, the STIFS network maintains a consistency and an accountability for all energy inputs to the economy. A final balance is made in quadrillion Btu for months, quarters, and years; then the results are compiled. A "shortage" is indicated if stocks fall below a specified, acceptable, minimum monthly level. The importance of the implied "shortage" depends on the individual fuel and must be interpreted in the broader framework of the entire network, because certain policies that are not implicit in the STIFS scenario assumptions might be used to alleviate the problem. The STIFS indicates a fuel surplus if inventories have accumulated at a higher rate than expected and have exceeded a prespecified upper limit. In the case of petroleum, the network is rerun with a lower import level or shifted refinery yields; in other fuels, forecast production may be curtailed.

### A.3 THE MIDRANGE ENERGY FORECASTING SYSTEM (MEFS)

#### Introduction

The MEFS is a national energy-forecasting system used by the Energy Information Administration to analyze energy prices, supplies, demands, and conversion activities. For selected years—currently 1985, 1990, and 1995—the MEFS provides projections of fuel import levels and patterns of activity for each of the major energy industries, including electric utilities and oil and gas producers and refiners, as well as detailed projections for energy use in the principal consum-

ing sectors. The MEFS framework consists of three major components: demand models, supply models, and an equilibrating mechanism that balances supply and demand to achieve a multiproduct, multiregion equilibrium. The relationship between these components is depicted in Figure A.3a.

The demand models are econometric and structural representations of the end-use sectors that estimate consumer demands for fuels and energy as functions of prices, the general level of economic activity, value added in manufacturing, demographic trends, the nature and extent of conservation programs, and other demand-related scenario conventions. Demands are calculated in MEFS for

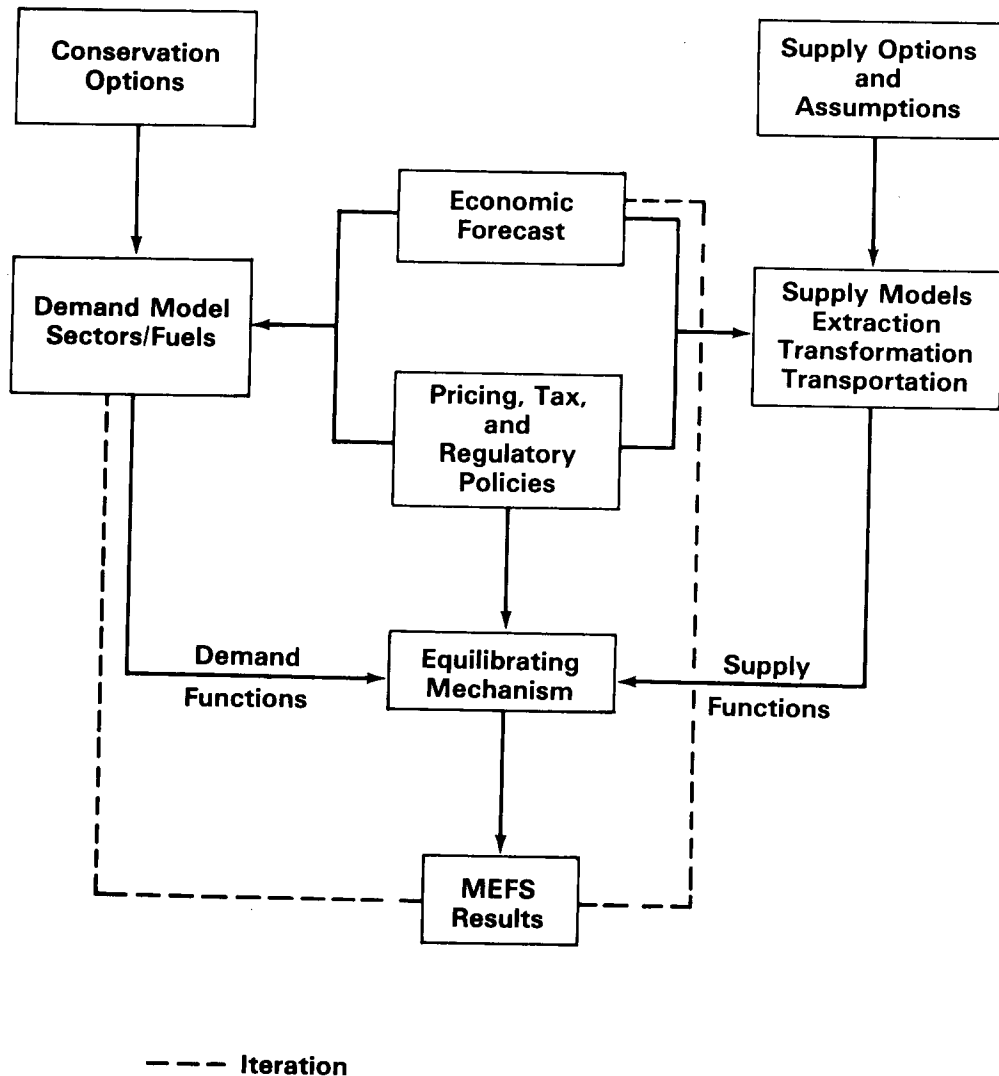

Figure A.3a Schematic of the Integrating Framework

refined petroleum products, natural gas, coal, electricity, and other fuels for each of the 10 DOE regions and for each of the major consuming sectors: residential, commercial, transportation, and industrial (including use of energy materials as raw materials).

The MEFS supply system is a detailed representation of U.S. energy resources and includes importation, production, conversion, and transpor-

tation activities. The integrated network of MEFS can be viewed as a set of energy sources that are called upon to satisfy demands. A simplified flow of fuels from production through conversion (by refineries or electric utilities) to points of demand is depicted in Figure A.3b. A set of satellite models is used to represent the supply for each of the major raw materials: coal, oil, natural gas, and uranium. The satellite models are built to simulate

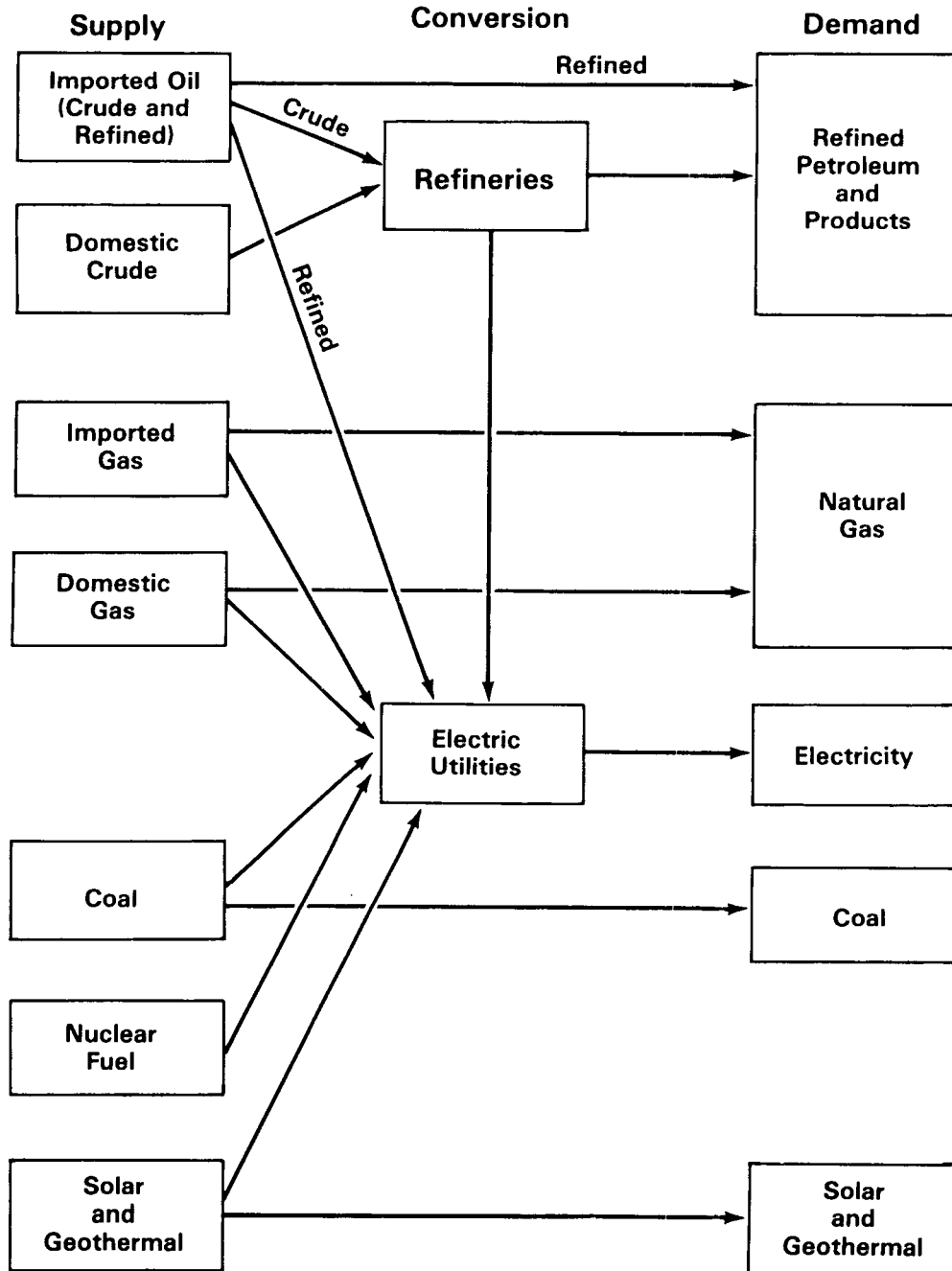

Figure A.3b Simplified Flow of Materials in the MEFS Integrating Model

the response of the specific industries to price changes. The supply representation also includes process models to represent U.S. refineries, electric utilities, and synthetic fuel plants, all of which convert raw materials into consumable forms of energy. The satellite models are depicted in Figure A.3c.

The various sectors of MEFS are linked by a distribution network that represents the movement of raw materials or products from the points of production, import, or conversion to the locations at which they are converted or consumed.

The principal economic assumptions implicit in the MEFS model structure are the following:

- Market equilibrium conditions govern the purchase prices and quantities of fuel consumed subject to the constraints introduced by government regulations.
- Consumers substitute fuels on the basis of their relative prices.
- Suppliers are competitive and produce if the market price is at or above the minimum acceptable selling price.
- The prices paid by energy consumers are marginal fuel prices, except for electricity and natural gas, which are sold at average prices.

The use of alternative scenarios in MEFS permits the evaluation and analysis of specific energy-related issues. Essentially, scenarios are implemented by variations of specific model structures or model parameters. For example, a scenario may represent the implementation of a new tax program. Changes of the value of certain model parameters or input data are made to examine the sensitivity of results to specific data elements.

With the exception of imported oil prices, the three *Annual Report* base forecasts contain the data and assumptions that are thought most likely to exist in the future if current Federal policies remain in effect. Alternative scenarios, called sensitivity analyses, show the impact of changing the principal assumptions.

## Components of MEFS

### Regional Structure

Regional structure in MEFS details production, distribution, conversion and consumption of energy. The primary purpose of the regional detail is not to provide results for regional analyses, but

rather to develop more representative national figures. Throughout MEFS, the choice of regional structure is governed largely by the availability of data for that segment of the energy system. Specific regional details are included in the following descriptions of each MEFS submodel.

### Demand Models

The sectoral demand models are satellites of the MEFS integrating model, as depicted in Figure A.3c. Given initial fuel price projections, the demand models determine fuel quantities consumed, as well as own- and cross-price elasticities for 30 sector-specific products in each of the 10 demand regions for each target year. These quantities, elasticities, and the corresponding price assumptions serve as principal inputs to the integrating model. The demand regions are coincident with the 10 DOE regions depicted in Figure A.3d.

### Residential

The MEFS residential energy-use submodel is an economic-engineering simulation of energy use in the residential sector. It is used to forecast residential demand for energy by fuel (electricity, oil, natural gas, and liquid gas) and for eight end-use functions (space heating, water heating, refrigeration, freezing, cooking, air-conditioning, lighting, and other) in three types of housing (single-family units, apartments, and mobile homes).

Major submodels in the simulation include the housing, market-share, and technology models, as well as various econometric models to estimate price and income elasticities. Energy use for a given year is determined by the individual end-use as a function of the household number and size forecasts, individual fuel-market penetrations, equipment efficiencies, and utilization intensities. Energy prices are exogenous and thus drive the other factors. Moreover, the configuration of energy use changes over time in response to incremental changes of stock for energy-using equipment.

### Commercial

The MEFS commercial submodel is an economic-engineering simulation of commercial energy use. It provides forecasts of energy demand for five end-uses (space heating, water heating, cooling, lighting, and other) and four fuel types (gas, electricity, oil, and liquid gas) in 10 commercial

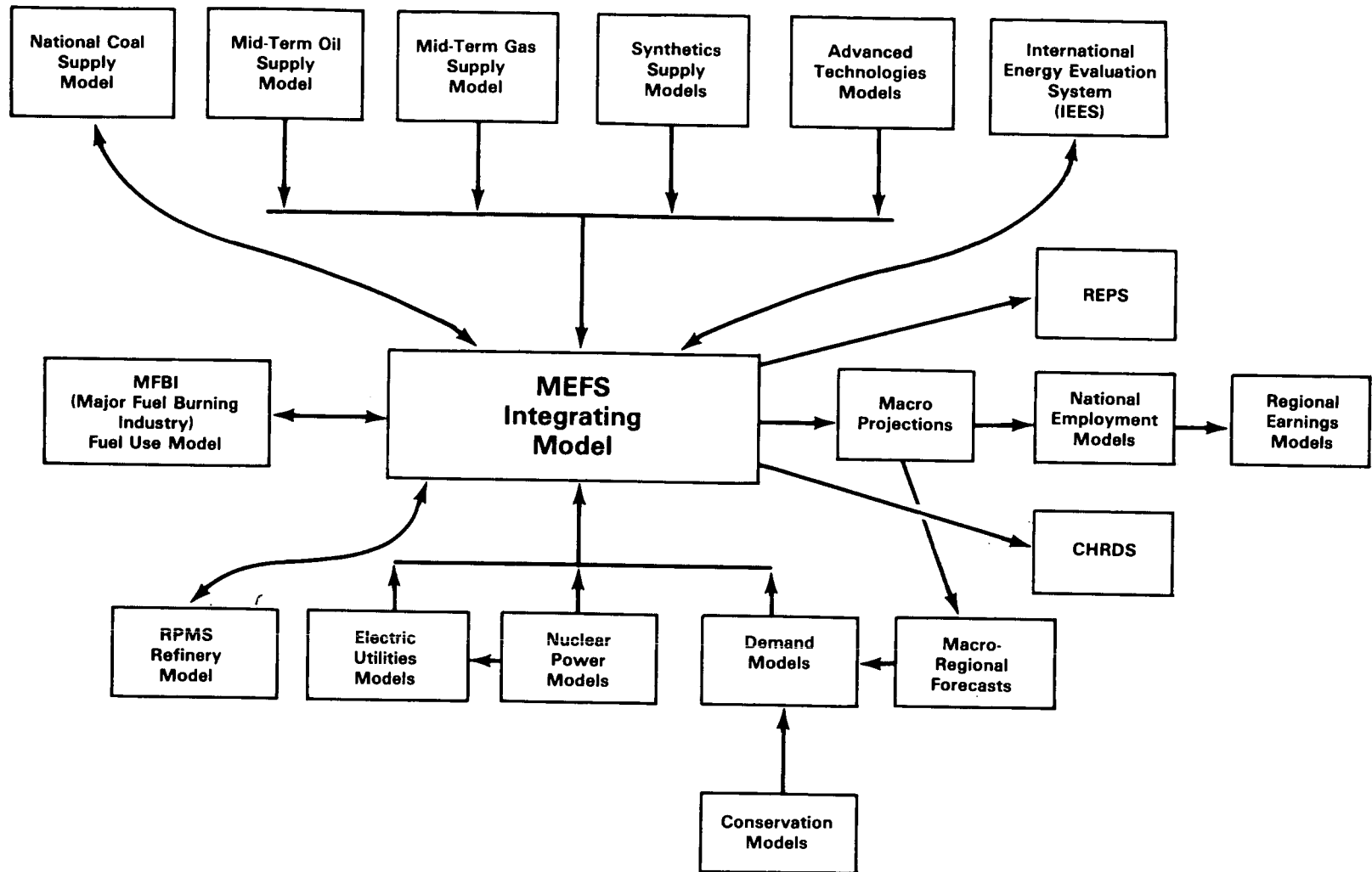

Figure A.3c MEFS Satellite Models



tent of the resource base. For this reason, the production models within MEFS simulate expected production capabilities, given the resource base of the energy sector under consideration and the assumption that producers individually seek to maximize their profits. Each of the supply sub-models is formulated by using a microeconomic perspective that is based on investment planning in which life-cycle costing techniques are used to predict future raw material and product availability.

## Coal

The national coal model provides supply functions for 11 categories of coal in 12 coal supply regions. These regions, depicted in Figure A.3e, correspond to the traditional mining regions defined by the U.S. Bureau of Mines. Each region is relatively compact and contains only a few categories of steam coal or steam and metallurgical coal. Coal is differentiated within MEFS by both sulfur and Btu content.

Transportation costs constitute a substantial part of the total cost of coal. Consequently, within MEFS, the more compact the coal region is, the better the estimate of transportation costs. Thus, even though some regions such as central and southern Appalachia produce the same categories of coal, the two regions are modeled separately to provide better estimates of coal transportation costs.

As with all supply functions in MEFS, step functions approximate the individual coal-supply curves. For each type of coal, the steps of the supply curve represent the development of a specific mine type. Deep mine type is differentiated by depth, seam thickness, and annual capacity. Surface mine type is differentiated by an overburden ratio and an annual capacity. The lowest cost step on the coal supply-curves generally corresponds to existing mines or mines that are about to be opened. In such instances, capital costs are sunk (or mostly sunk), and mines would operate as long as the marginal revenue is at least equal to the operating costs. The higher cost steps reflect the capital recovery necessary to open new mines.

The production capacity of new mines is the maximum annual production that the former Bureau of Mines estimated a reserve base could sustain for 30 years, including the effect of mine closings. Reserves that are not committed to existing mines are allocated to categories of new mines, thus reflecting different costs for different

types of surface and deep mines. The amount of coal in each cost category is estimated by statistical distributions appropriate to the specific region and coal type. The cost of coal is determined by an income-statement simulation that has four major cost determinants: capital cost, labor cost, and productivity, power and supplies cost, and rate of return. Preparation costs, reclamation costs, and State severance taxes that also affect the cost of coal are included in the simulation.

## Oil and Gas

Oil production is modeled for 13 regions: 8 regions onshore in the lower-48 States, 3 regions in the Outer Continental Shelf (OCS), the Alaskan North Slope, and southern Alaska. These regions are based on the National Petroleum Council's (NPC) classification in which Alaska is split into two regions, and NPC regions 8, 9, and 10 are aggregated. The regions are depicted in Figure A.3f.

Fourteen natural gas regions are modeled; they are identical to the oil regions, except that NPC regions 8 and 9 are combined into a single natural gas region, as shown in Figure A.3g.

Satellite oil-supply models provide supply functions for domestic crude oils, in addition to associated natural gas and coproducts, in the appropriate oil production regions. In MEFS, the crude oils are differentiated by sulfur content and American Petroleum Institute (API) gravity. Satellite gas-supply models provide supply functions for natural gas and coproducts for each of the gas-producing regions. The oil and gas submodels use similar methodologies to derive the supply functions. The estimated resource base is obtained from updated United States Geological Survey (USGS) data for each NPC region.

New oil in a region is partitioned into primary and secondary reserves according to historical regional recovery factors. An exponential curve represents declining production over time, with secondary production beginning several years after the oil has been added to the reserves. The discounted cash flow for a barrel (or thousand cubic feet) of reserves is calculated for each oil (or gas) price on the supply curve. An initial finding rate is established by examining the recent history of barrels of oil (or cubic feet of gas) added to reserves-per-foot-drilled. All wells are considered for natural gas and only exploratory wells for oil.

Once the value of a new unit of reserves and the cost of discovering those reserves have been

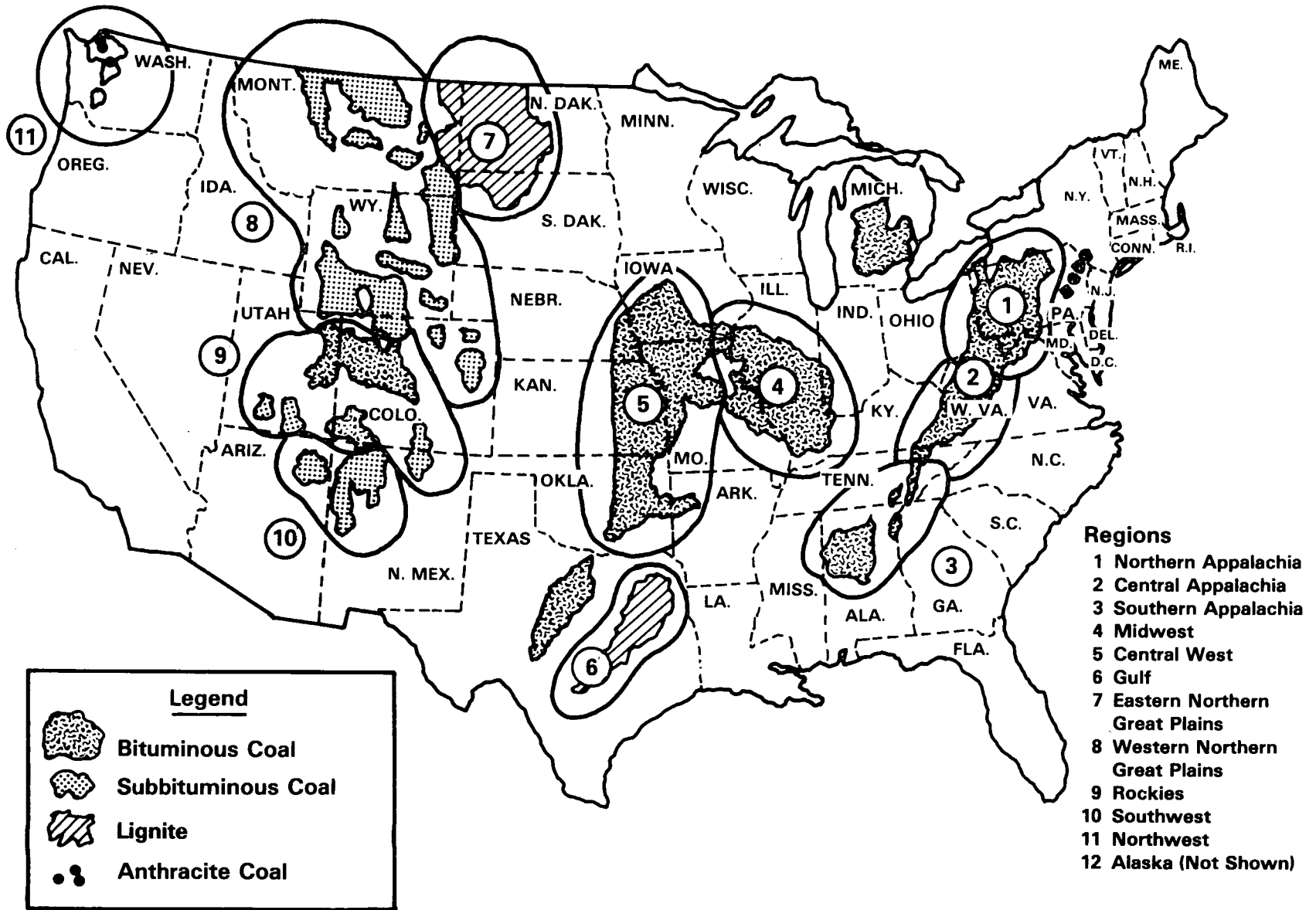

Figure A.3e MEFS Coal Regions

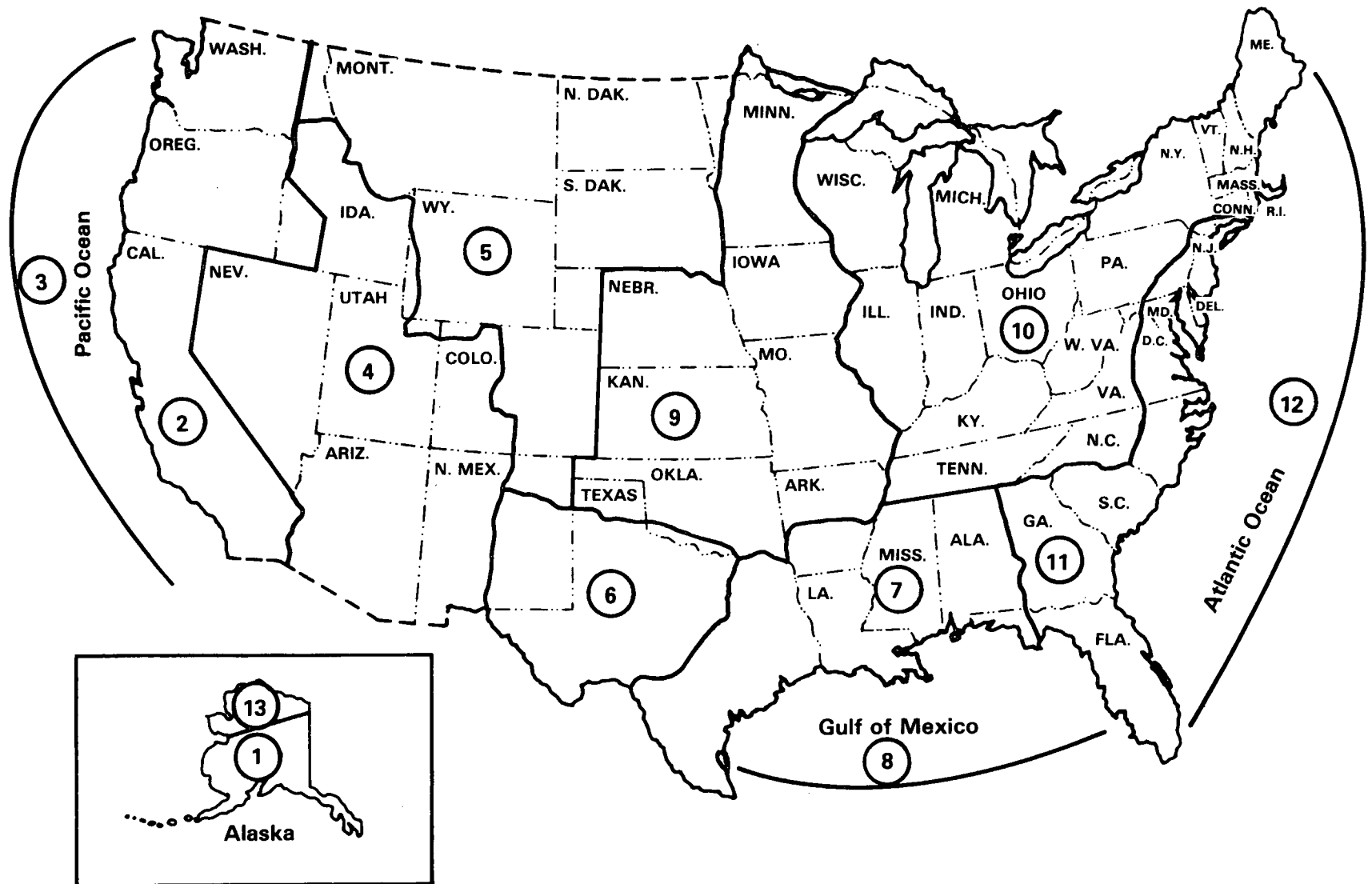

Figure A.3f MEFS Oil Regions

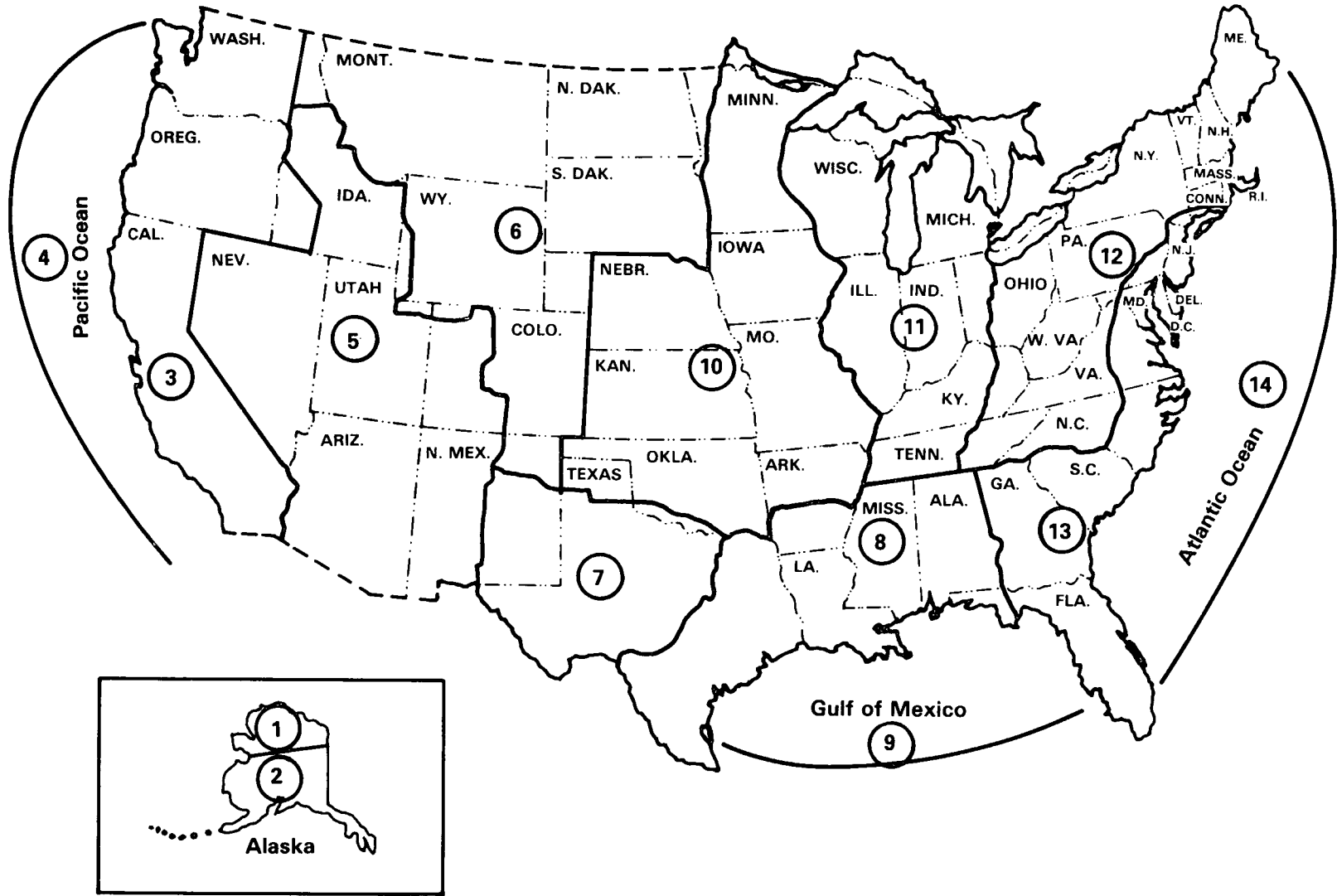

Figure A.3g MEFS Natural Gas Regions

established, the cumulative feet worth drilling for each price level are determined. The drilling effort begins with the current rate or activity, is increased, and then decreased to reflect the growth and subsequent decline of activity. During the simulation, the initial surge of activity becomes greater as the price rises; however, the surge does not occur if there is a price decline. As the yield-per-foot-drilled declines, the net rate of activity also declines and eventually decreases to zero when profitable opportunity disappears. As new drilling occurs and reserves are added, production from the added reserves occurs every year. The production from reserves is added to determine the amount of supply in any given year at a given price.

Tertiary oil production and Alaskan oil and natural gas output are estimated separately. Estimates of enhanced natural gas recovery, shale oil, tar sands, and the Naval Petroleum Reserve are developed outside the modeling framework.

### **Electric Utilities**

The MEFS electric utilities submodel simulates planning decisions for construction and operation of electricity generation facilities. The MEFS chooses the number and type of generating plants required to meet load demands that vary both daily and seasonally. In so doing, it models the consumption of fuels (coal, residual oil, distillate oil, natural gas, and uranium) that are transported from domestic producing regions and importing regions to the utilities. The MEFS also models the conversion of fuels to electricity, and takes into account the energy losses and the release of that energy through the transmission and distribution network to satisfy demand for electricity in the end-use sectors.

The MEFS utility regions correspond to the 10 DOE regions (MEFS demand regions) depicted in Figure A.3d. The model allows electricity demand to be satisfied only by generation in its coincident utility region. The model does not explicitly include power dispatched from one region to another, except by physically locating the plant in another region.

The key factor in modeling the behavior of utilities is that electricity cannot be stored; it must be produced on demand. Therefore, utilities must own some equipment that operates most of the time, and some that runs only during peak demand periods. The yearly demand levels for electricity

are represented by regional, annual-load duration curves (see Figure A.3h).

The MEFS simulates baseload, cycling, daily peak operations, and seasonal peak operations. Baseload is characterized by a constant level of customer demand. Cycling load provides electricity for a demand that varies by time of day. Daily peakloads must be met during a few peak hours of the day and seasonal peakloads during extremely hot or cold weather.

The major types of generation equipment include coal-fired steam (with or without scrubbers), residual-fired steam, gas-fired steam, simple-cycle turbines, combined-cycle turbines, hydroelectric power, and nuclear power. Each type of generating plant has its own cost and engineering characteristics.

In most cases, baseload capacity is provided by hydroelectric power, coal, or nuclear plants. Cycling-load capacity is provided by hydroelectric power, coal, residual-fired steam, gas-fired steam, or combined-cycle plants, and peakload capacity is provided by hydroelectric power or turbines. In general, equipment with higher capital costs and lower operating costs is best suited for baseload capacity, and equipment with lower capital costs but relatively higher operating costs is better suited to satisfying peakload demand.

The regulated rates that electric utilities charge customers are the average cost of electricity. These rates are based on actual costs of equipment rather than on marginal costs. Thus, in MEFS, prices to consumers are average prices, but utilities base their investment decisions on marginal production costs.

### **Refineries**

The MEFS refineries submodel is a simplified, aggregate-planning simulation that represents the conversion of crude oils (both domestic and imported) into seven major refined products: naphtha, gasoline, jet fuel, distillate, residual, liquefied petroleum gases, and other. Crude oils processed by refineries differ in physical and chemical characteristics, and consequently must be processed differently; processing costs vary among crudes and each crude produces a different mix of products. The MEFS refineries submodel differentiates crude oils by characteristics such as specific gravity and sulfur content. The refineries submodel can also distinguish approximately 25 different domestic and imported types of crude oil.

The MEFS refinery submodel represents the characteristics of existing refinery capacity by calibrating and adjusting the model off-line to simulate the refinery configuration that is necessary to meet demand. Provision is also made for modeling the expansion of refinery capacity by providing for construction of new facilities. As with utilities, the inclusion of new capacity requires that capital expenditures be made. In MEFS, these costs are annualized capital charges for constructing new refinery capacity.

The MEFS' simulation selects and transports specific crude types to refinery regions, specifies necessary capacity expansion, and produces and transports refined products to the consumers in a way that minimizes the refiner's costs. Final product prices are determined by iteration with a detailed process model as demand levels fluctuate in response to prices. The refinery regions used by MEFS are the five Petroleum Administration for Defense Districts (PADDs), with PADD's 1 and 2 divided into two regions, as depicted in Figure A.3i. Within MEFS, crude oil is transported into the refinery regions from the oil production or import regions, and refined products are transported from the refinery regions to the utility or demand regions by pipeline, barge, or tanker.

### Transportation

All production, conversion, and consumption activities within MEFS are linked by a transportation network. The transportation submodel provides interregional links to model the transportation of coal by barge and rail, the transportation of natural gas by pipeline, and the transportation of crude oil and refined products by tanker, barge, and pipeline. The cost of shipping each material by each mode for each link is calculated in the submodel, with the least costly mode being selected. In general, there is no capacity constraint for quantities that may flow through any given link. There are, however, pipeline constraints for transportation from Alaska and the northern tier.

### Solution Procedure

The solution methodology in MEFS balances supply, conversion, and demand forecasts by computing equilibrated quantities and prices in a partially regulated market. Underlying the procedure is the assumption that energy consumers and suppliers, subject to the constraints imposed by Government policies, will act in their own best

interest. Consumers act rationally to maximize their benefits, and producers act rationally to maximize their profits. With this assumption, demand increases with decreasing price, and supply increases with increasing price. Accordingly, the supply and demand functions are the general form depicted in Figure A.3j; market equilibrium is found at the intersection of the curves. Because perfect market conditions do not exist in the real world, the MEFS representation approximates reality.

The MEFS finds a market equilibrium point at which supply equals demand through an equilibrating algorithm. Demands are estimated by first generating a macroeconomic forecast that uses energy prices taken from a previous MEFS solution. The macroeconomic forecast is then regionalized, and the econometric and structural demand models are provided key values that develop the demand curves used in MEFS. Because the demand curves are computed by using expected energy prices, several iterations may be necessary to pass the prices from MEFS and the new demand curves back to MEFS to obtain estimates near the equilibrated prices.

To represent the supply set with a linear program, steplike approximations to the supply curves are generated as indicated in Figure A.3j. After incorporating these step-function approximations and the initial demand estimates into the linear program and solving it, MEFS obtains a set of prices, demands, and a candidate equilibrium solution containing activity levels. This solution to the linear program is not automatically in equilibrium, because the linear program cannot directly provide for fuel substitution effects (except in the electric utilities sector). To handle this problem, the linear program is solved several times, and a revised set of demand estimates is provided for each iteration. These demand estimates are calculated by using a continuous demand curve derived from the initial prices, quantities, and own- and cross-elasticities obtained from the demand models.

When the prices and associated quantities for a particular solution of the linear program are within the set tolerance limits of the previous solution, an equilibrium is obtained. If an equilibrium is not obtained, new levels of demand are calculated from the previous solution by taking into account cross-elasticity effects for fuels. The linear program is revised to reflect the new demand levels and then solved again. This iterative process continues until an equilibrium solution is

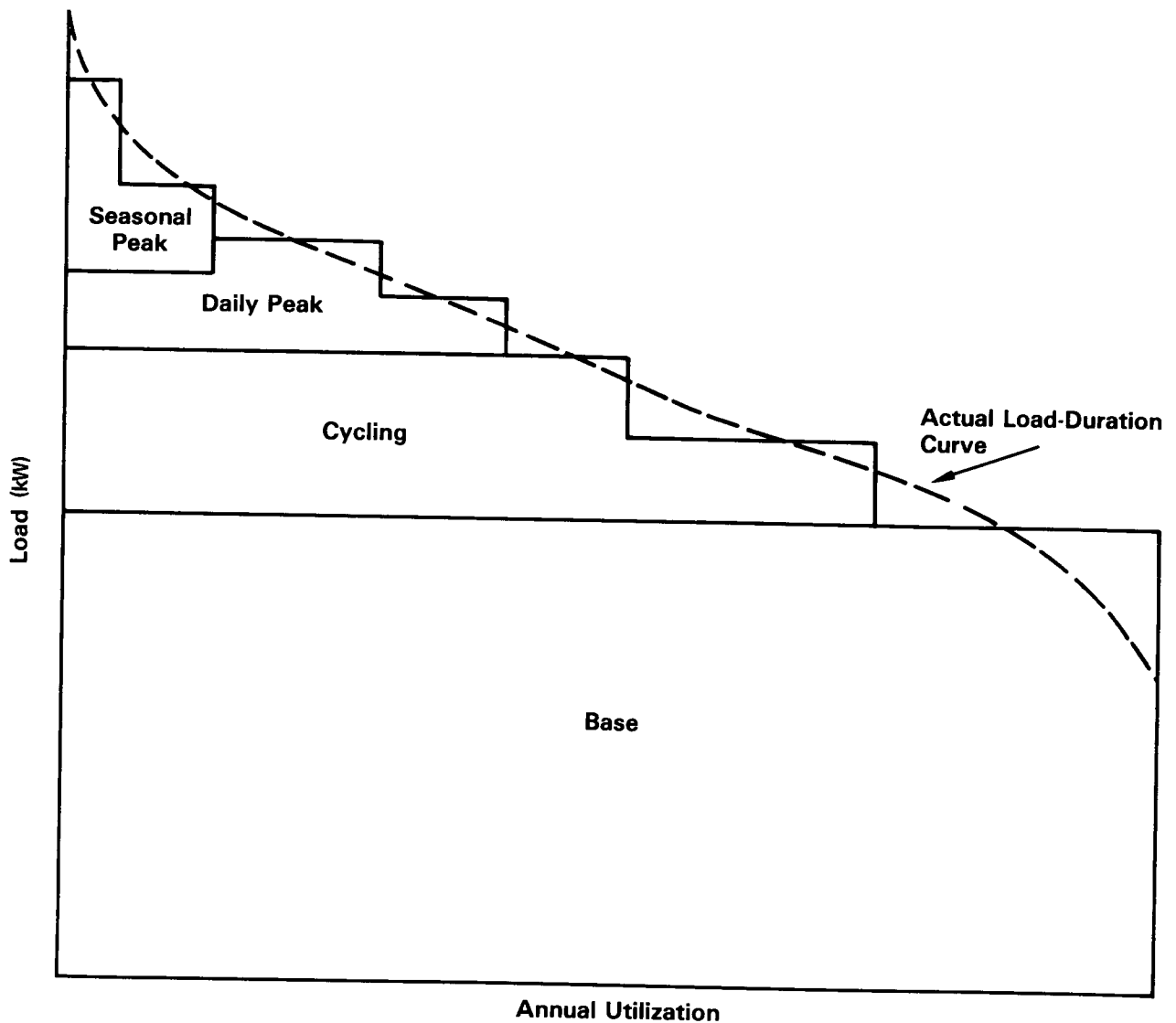

**Figure A.3h Representative MEFS Electric Utility Load Duration Curve—Linear Approximation**

obtained within the prescribed tolerance limits. By convention, an equilibrium solution in MEFS is reached when the absolute value of the change in each price and the change in each quantity between two successive iterations is less than or equal to 2 percent.

#### **A.4 THE LONG-TERM ENERGY ANALYSIS PROGRAM**

##### **Introduction**

The Energy Information Administration uses the Long-Term Energy Analysis Program's (LEAP) modeling framework to develop long-term

energy supply, conversion, and demand forecasts. Currently, national level projections are developed for the period 2000–2020 in 5-year intervals beginning with 1975. The methodology utilizes a dynamic, partial equilibrium representation of the multitime period supply–demand situation.

The LEAP model does not impose one universal goal in which the allocation of resources and demand is determined by optimization of a single objective function. Rather, equilibrium operates through market or decentralized decisionmaking so that the optimizing behavior can occur within each activity. The LEAP model does not immediately switch between alternatives based on small changes in price. The relative price advantage only determines an ultimate market share. Then a

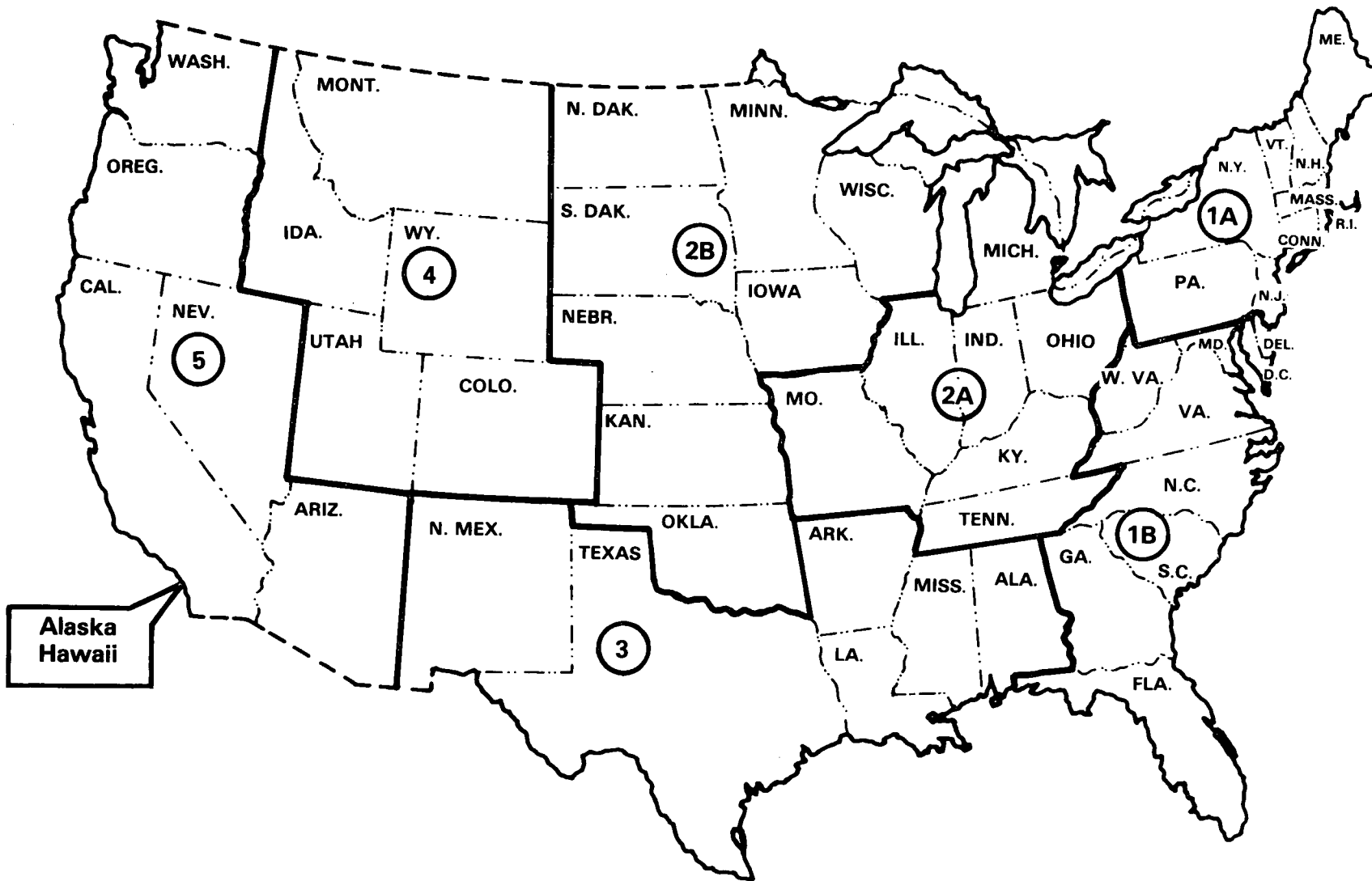
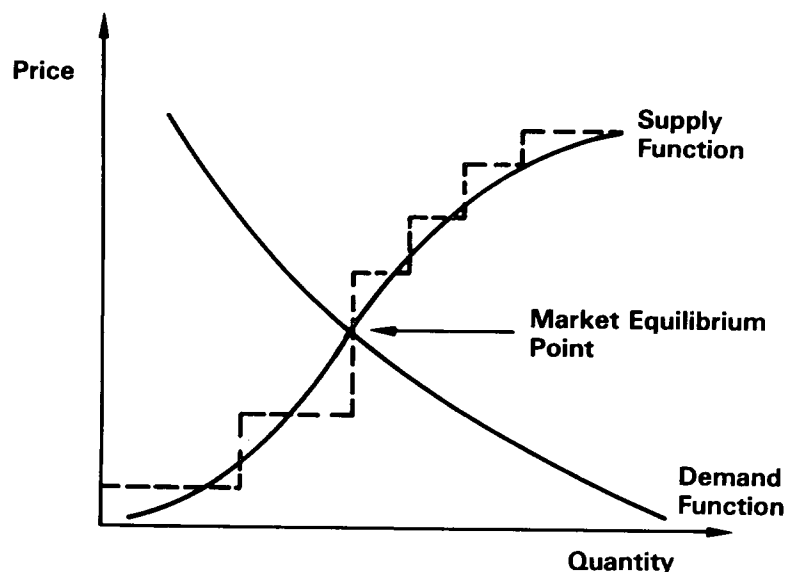

Figure A.3i PADD Regions (MEFS Refinery Regions)





**Figure A.3j Typical Supply and Demand Curves**

lagged adjustment based on a distribution of perceived prices smooths the switching behavior. For example, a new technology captures an increasing share of the market as its price advantage increases, as opposed to capturing the entire market as soon as it becomes economically competitive.

The structure of LEAP can be displayed in a network format to describe the flow of energy among sectors from source to destination. There are nine sectors in the LEAP structure used in the *Annual Report to Congress, 1979*; each sector represents a major area of energy activity (such as coal production or industrial demand). Activities within each sector represent a technology, supply source, or end-use process in the energy system. These activities are described by mathematical relations that use quantity and price information to connect the activity to the rest of the energy system. The mathematical relations are expressed in the form of process models, which describe supply, demand, conversion, allocation, and transportation activities in the network.

Thus, the LEAP modeling system is constructed from the following:

- A generic set of standard energy process simulations
- Specific data for each application of a generic simulation
- A network defining how these simulations are connected to form the energy model.

## Process Models

The basic components of the LEAP model are the individual process models that describe activities within the system. These generic processes are based on structures that are common to a given class of activities. The mathematical relations that characterize each process can be economic (derived statistically from historic data), subjective (based on expert judgment), or some combination of these two. These relations are both physical, describing how physical flows interact over time, and behavioral, describing human choices; thus a great deal of flexibility is permitted.

### Demand Processes

The end-use processes represent demands for various types of energy services, such as space heat or vehicle-miles. Unlike many energy models that regard fuel demand as final demand, LEAP represents final demand in terms of the demand for services, which is derived from projections of end-use activity. Thus, the end-use demand model is not concerned with fuel or technology competition; these are treated in conversion and allocation processes elsewhere in the end-use sectors.

The demand modules are characterizations of the growth of end-use service demand as a function of sectoral economic activity. Demand for a service in any period is dependent upon demand in the preceding period, the current price of the

service, and the economic growth index for that sector.

### Supply Processes

The supply processes describe the technology and economics of representative resource production activities (such as oil production and coal mining). Production of primary energy resources is disaggregated into appropriate supply regions: Alaskan and Lower-48 States oil and gas; Eastern, Western, and midcontinent coal. The LEAP model uses two types of supply process models, representing different assumptions concerning the production profile of a well or mine. The process model used for coal and uranium production assumes a constant level of output over the life of the facility (mine) until the resource is exhausted. In the oil and gas process model, output declines exponentially to exhaustion.

The geologic potential of a region is represented by a long-term relationship between minimum acceptable price and cumulative recovery effort (such as oil drilling). These curves characterize the marginal minimum acceptable price for the next unit of cumulative commitment for the resource and are upward-sloping to capture the effect of resource depletion. However, developments in production technology and learning effects on production and operating costs can partially offset depletion-based cost increases. Given the resource assessments, a financial submodel computes the minimum acceptable price of production. Future resource calculations are based upon perfect expectations of future prices (rather than on constant real prices, for example).

The current price incorporates an economic rent component, which represents the maximum present value of the benefit of deferring production to any future time period. The problem facing a depletable resource producer is how to allocate a fixed amount of resource over time. Supplying a unit at any one time carries with it the opportunity cost of not being able to supply that unit at some other time. The price of a resource in LEAP is equal to the current cost per unit plus a scarcity rent. Production decisions are thus based on each producer maximizing the present value of future profits.

### Conversion Processes

The basic conversion process describes the technology and economics that relate energy inputs to

outputs via efficiencies. Examples of conversion processes include the refining of crude oil into petroleum products and the conversion of natural gas into space heat (using a furnace). Model parameters account for technological change, thermal efficiency, and capital and operating cost changes. A capital cost premium is incurred for use of a technology before the date of commercial availability. The relations for a basic conversion process are straightforward, physical accounting flows of one or more inputs being converted to a single output. In each period, production capacity needed to meet the quantity demanded is evaluated by determining the contribution from prior capacity additions and retirements. Capacity requirement is a function of utilization factors, which are dependent on plant vintages and current prices of the product. New capacity is added as required.

A more complex version of this process model is the electric power conversion process, which represents the technologies that generate electricity (e.g., nuclear, coal, gas, and oil-fired powerplants). The electric power process is distinguished from the basic conversion process by the need to represent the fluctuating demand for electric power. Each electricity conversion process is characterized by three loading categories: base, intermediate, and peak.

As fuel prices change and new technologies are introduced, utility plants are loaded to minimize the cost of producing electricity. The model considers the fluctuating demand for electricity, the high cost of storing electricity, and the cost and efficiencies of the different technologies that are available to generate electricity. The subnetwork used is composed of an electric power load disaggregation process, an allocation process for each load category, and several electric power conversion processes.

### Allocation Processes

The allocation process represents the allocation of demand among competing sources of supply, such as the allocation of gas demand among alternative sources. A continuous market share function is used to represent market penetration as a function of competing fuels or technologies. In addition, this function contains parameters to capture intrinsic (nonprice) discrimination among sellers on the part of buyers and a behavioral lag term to reflect the rate of market penetration.

The market share captured by each technology is a function of the price of the energy product produced by each technology. The prices of different sources of supply are represented by Weibull probability density functions. Each supply technology ultimately captures the percent of the market corresponding to the probability that it is the cheapest source. The market process is assumed to be stochastic and to represent price uncertainty caused by the geographic diversity of prices occurring in the market and the variations in decision rules and conditions perceived by different buyers. A result of this characterization is that markets do not equilibrate price, because a probability always exists that a more expensive supply is perceived to be cheaper in a market and thus have a small market share.

The market share that a technology captures in a particular period is related to its share in the preceding period by a behavioral lag term. A separate lag is specified for (1) new demand, in which additional capacity is needed to satisfy increased requirements; and (2) old demand, in which a portion of the market is already captured by a specific source or technology. In the latter case, new capacity may be needed to replace retired or obsolete capacity.

### Transportation Processes

The transportation process represents the costs incurred in transporting energy materials between sources of supply and demand. Losses incurred in shipping are also represented in this process. For example, a transportation cost differential is added to the cost of Alaskan natural gas to reflect the cost of moving the energy from the production location to the point of use. Losses incurred in gas shipments are subtracted from the total gas shipped.

### Network Structure

Figure A.4a is an overview of the total LEAP energy system, with the links expressing flows of prices and quantities of energy products between the sectors. At the bottom of the network are processes describing primary resource supply: oil, gas, coal, and uranium. Processes at the top of the network represent end-use demands for energy by sector: residential, commercial, industrial, and transportation. In between are other processes describing market behavior, energy conversion,

and the transportation of energy. The two remaining sectors between supply and demand are the electrical utilities sector and the energy distribution sector.

The nine sectors represented in the LEAP model are: residential, commercial, industrial, transportation, distribution, electric utilities, oil and gas, coal-synthetics, and uranium. A detailed network of each sector is shown in Figures A.4a through A.4j. The activities contained within each sector are described below.

- Residential Sector—The residential sector covers the demand for services by three housing types: single family, multifamily, and mobile homes. End-use services for this sector include space and water heating, space cooling, lighting, refrigeration, cooking, and other gas and electric services. Technologies represented include conventional equipment (furnaces, air-conditioners) as well as newer technologies, such as gas and electric heat pumps and solar technologies. Photovoltaic generation of electricity for residential use is also represented.
- Commercial Sector—The commercial sector covers economic activity in financial, retail and wholesale industries, health and education services, and office buildings. The LEAP model determines an aggregate level of demand for each of the following services: space and water heating, space cooling, lighting, and other gas and electric services.
- Industrial Sector—The industrial sector includes the demand for services from several major industrial groups, including manufacturing, mining, and agriculture. The service demands in this sector are for direct and indirect heat, electric services, feedstocks, metallurgical coal, and lubes and waxes. Transportation services by rail, heavy truck, and water vessels are also included as industrial demands, although the fuel use is attributed to the transportation sector. Fuel used includes both conventional sources (oil, gas, coal, electricity) and renewable sources (biomass, solar). Industrial cogeneration and autogeneration of electricity are represented.
- Transportation Sector—The transportation sector consists of six modes: air, automobile, bus, truck, rail, and marine. The services demanded in this sector are expressed as passenger-miles, vehicle-miles, and ton-miles. The truck category is disaggregated into

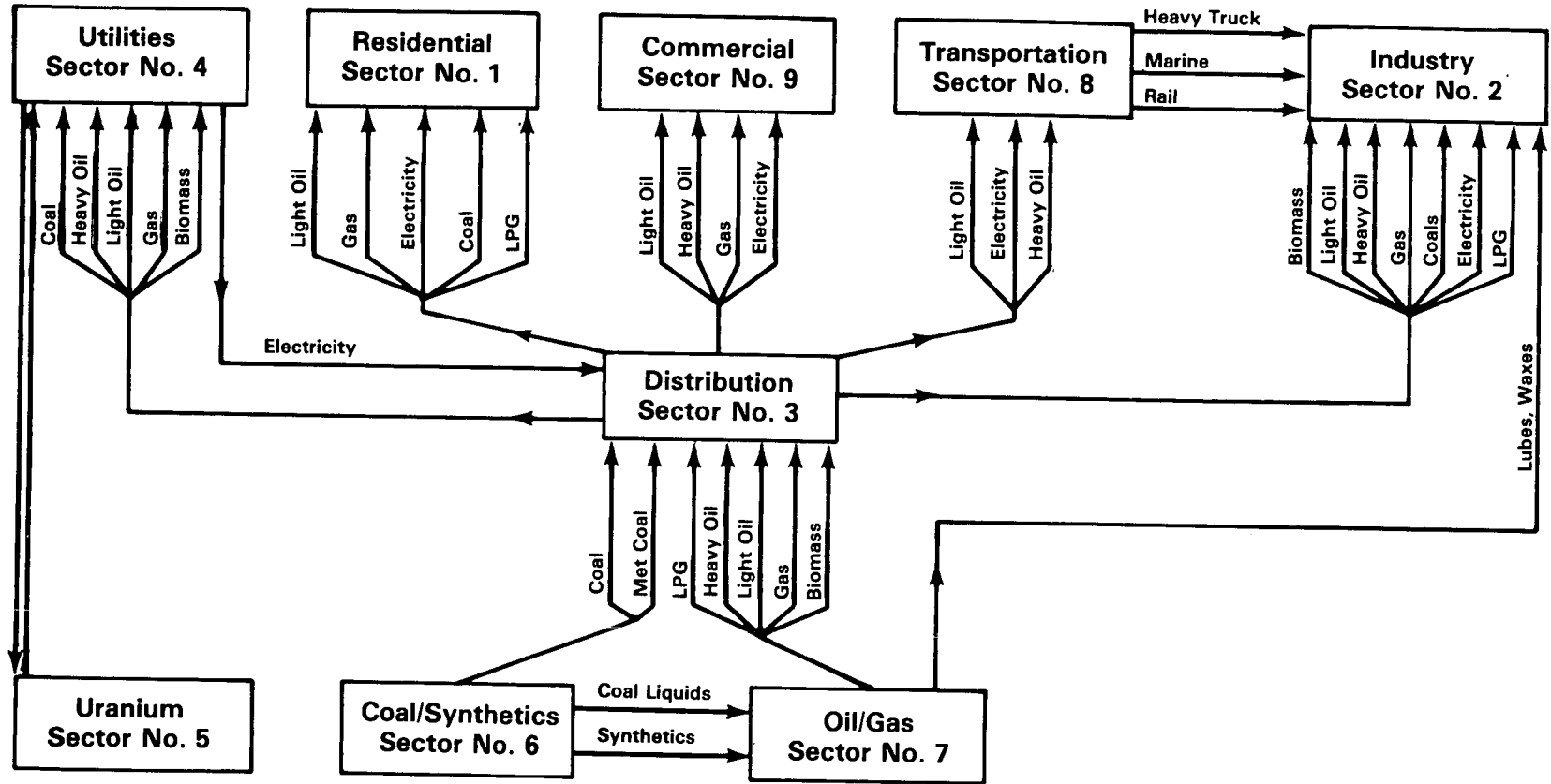

Figure A.4a LEAP Network



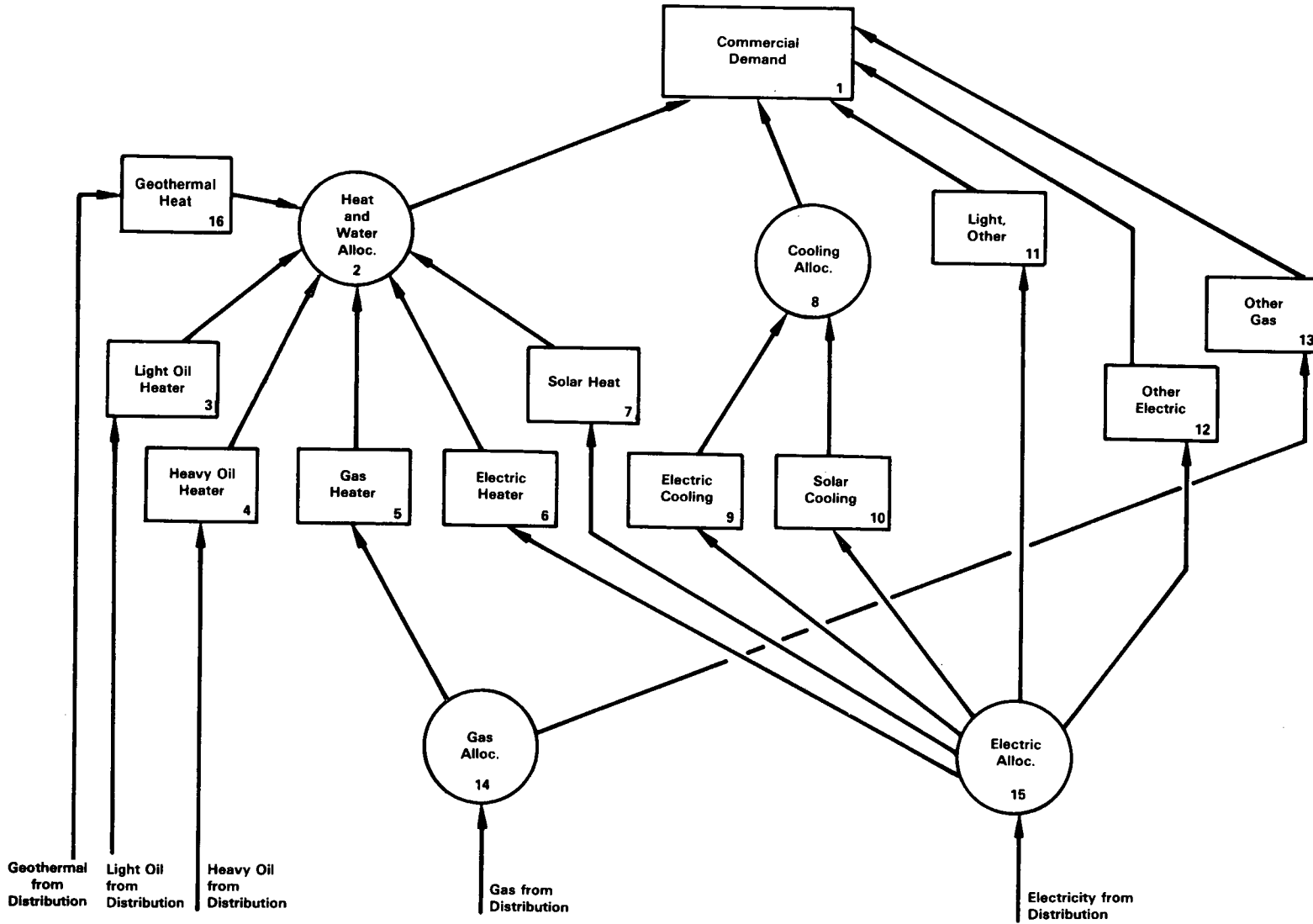

Figure A.4c Commercial Sector

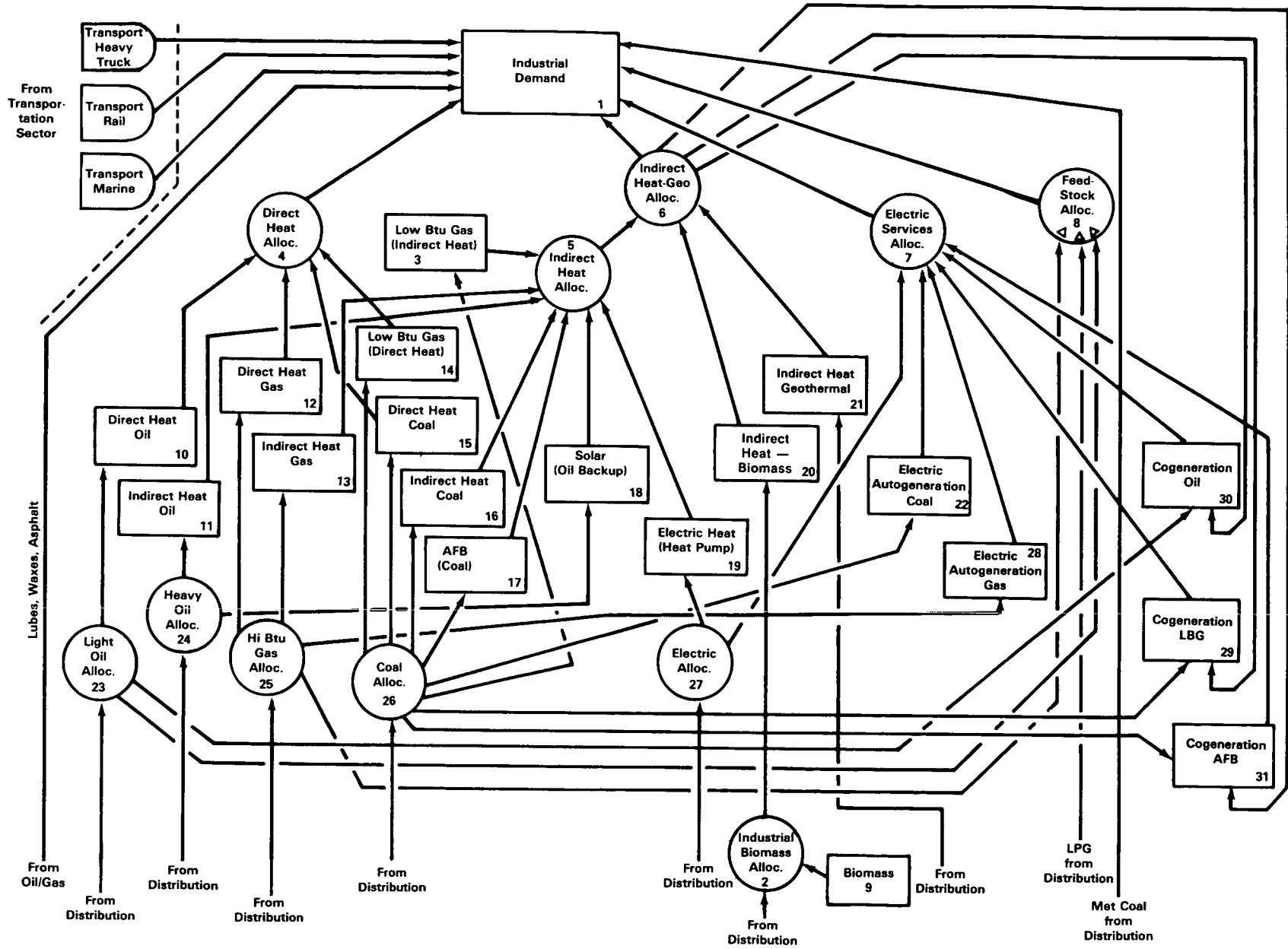

Figure A.4d Industrial Sector

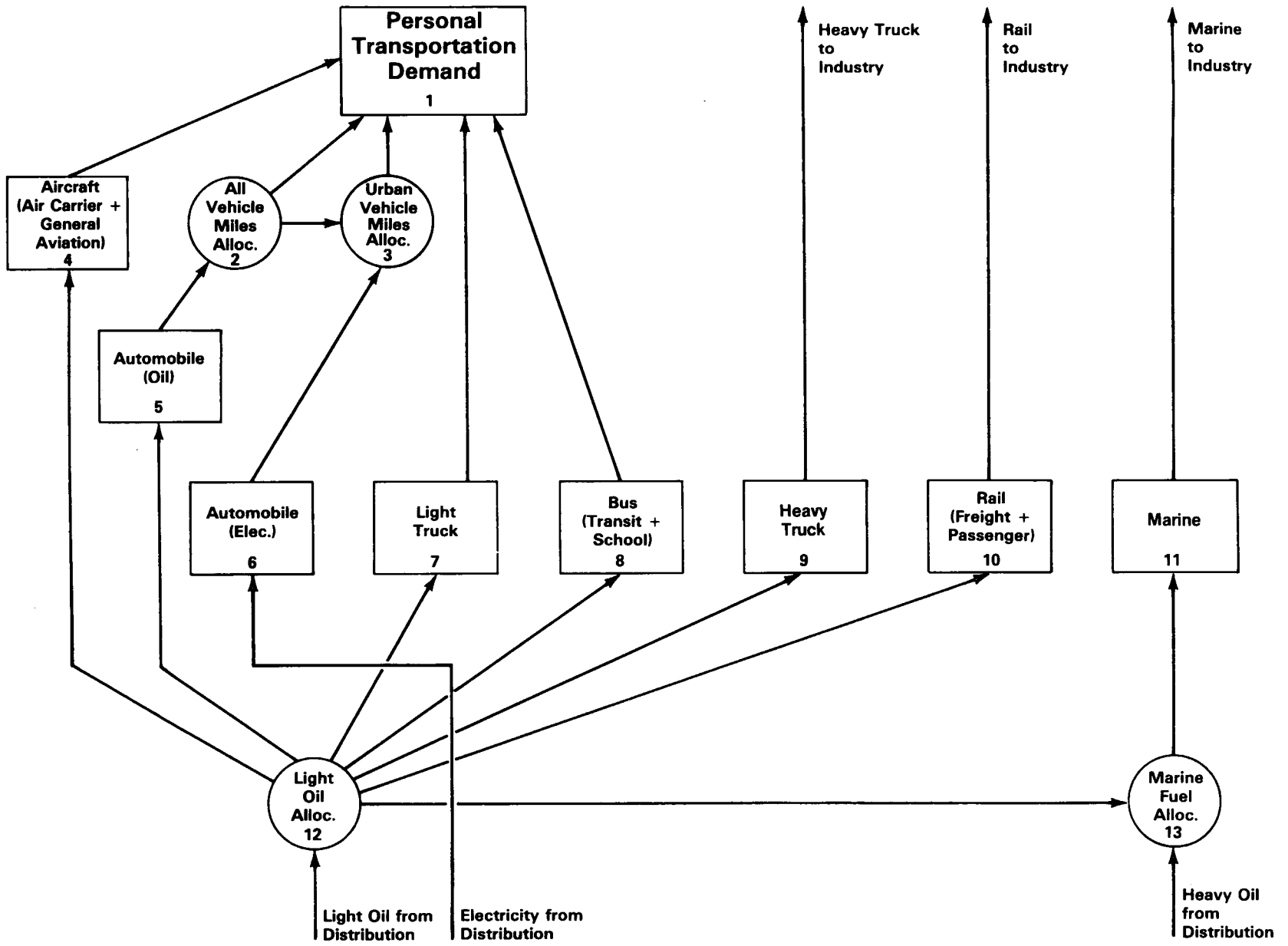

Figure A.4e Transportation Sector



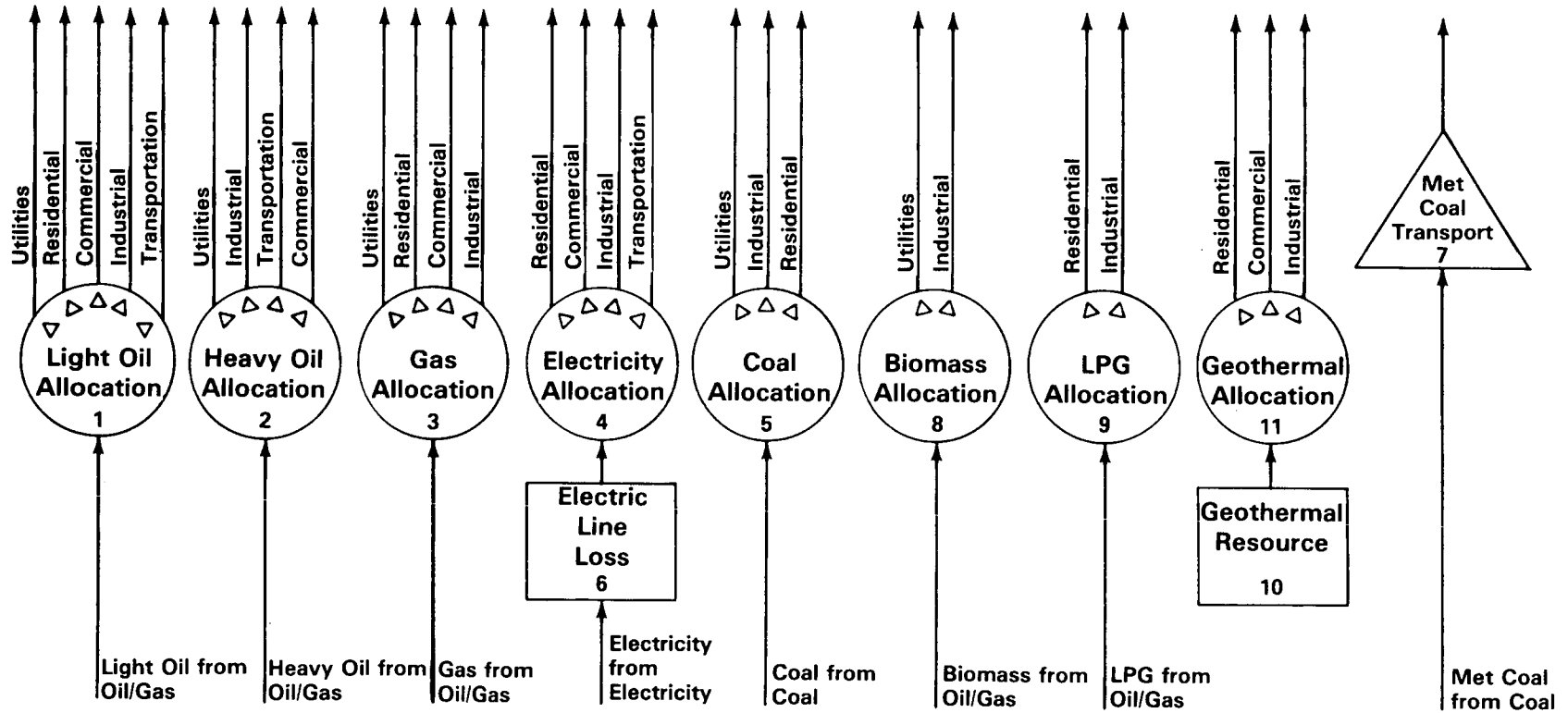

Figure A.4f Distribution Sector

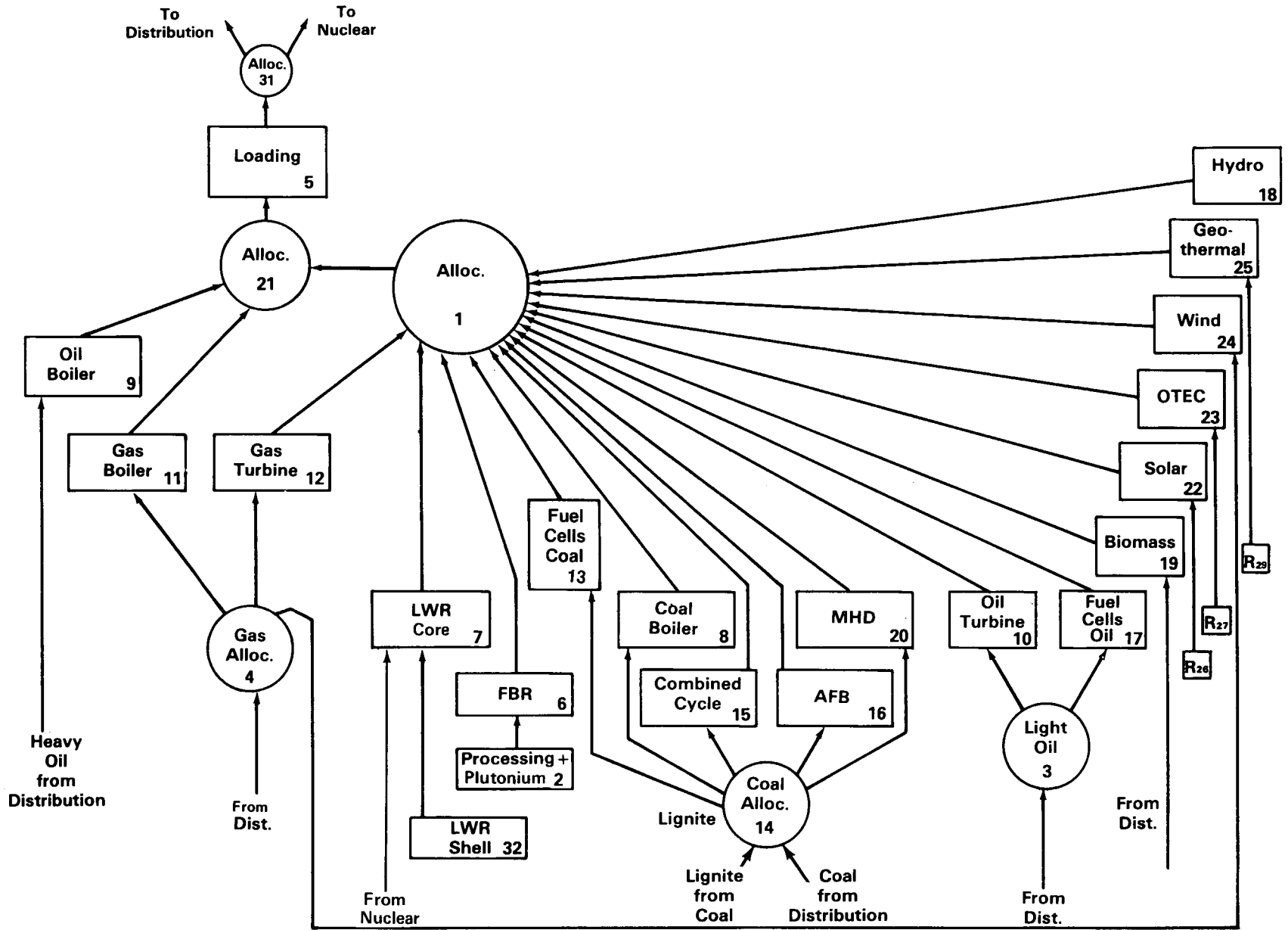

Figure A.4g Electricity Sector

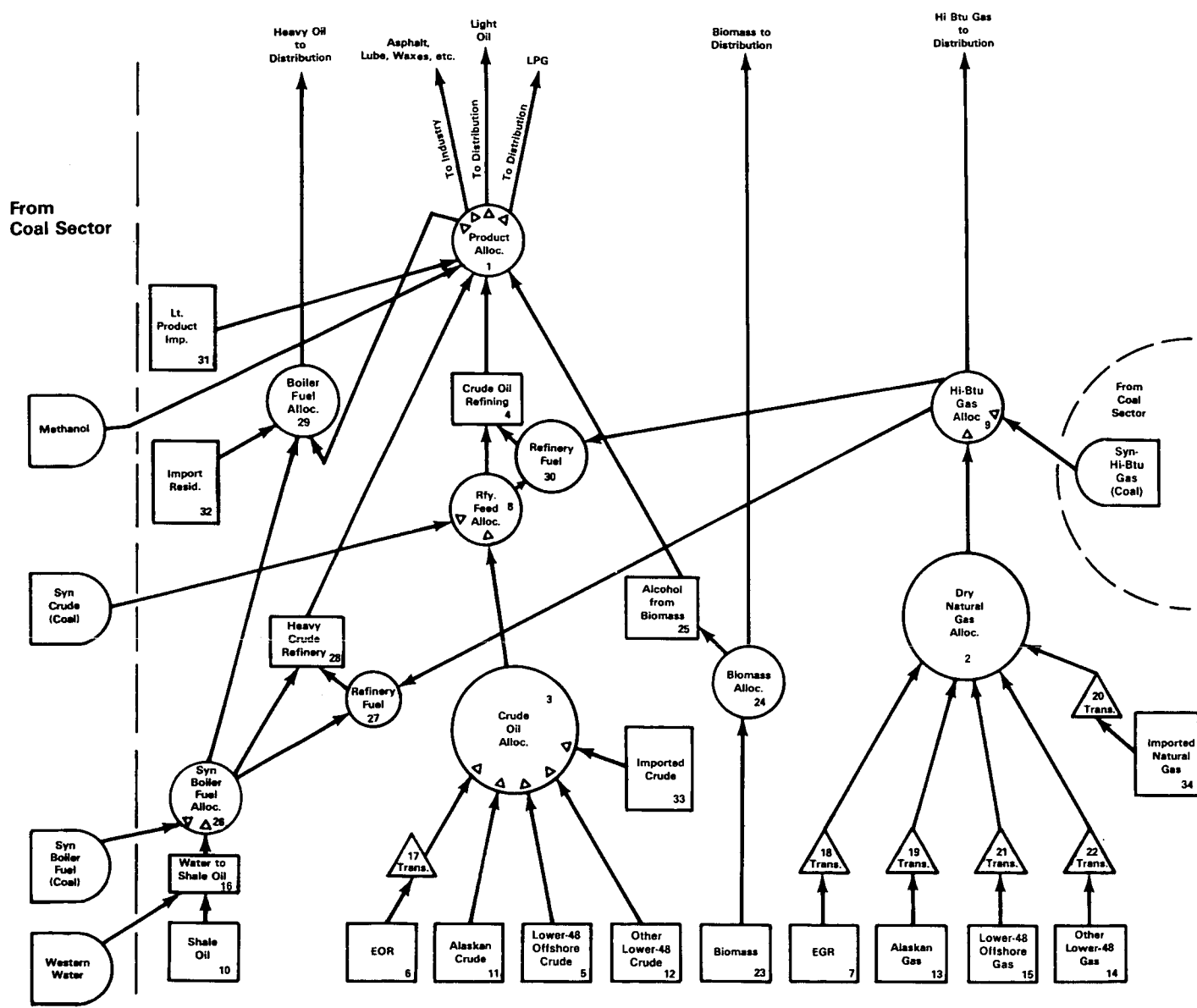

Figure A.4h Oil/Gas Sector

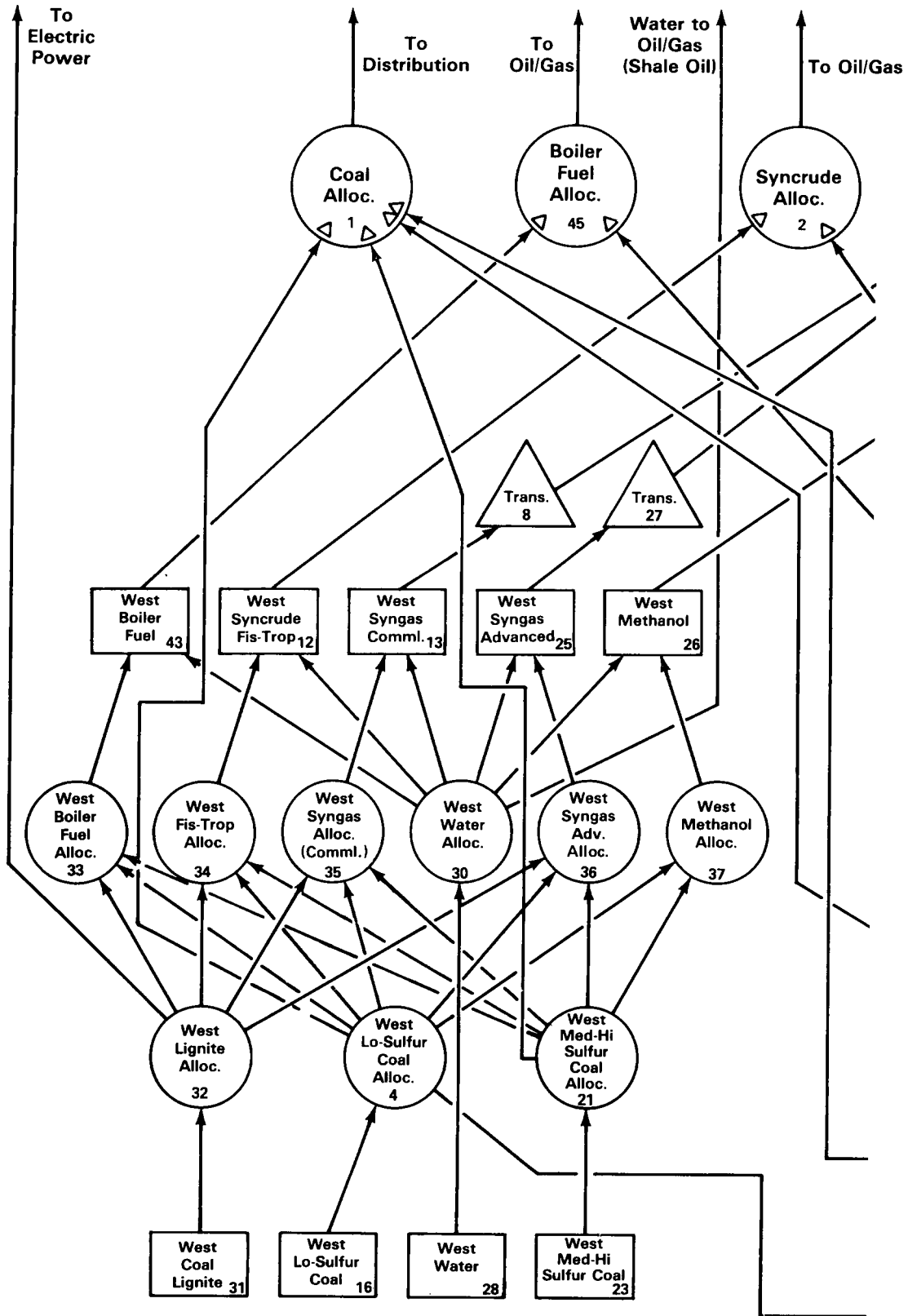

Figure A.4i Coal Sector

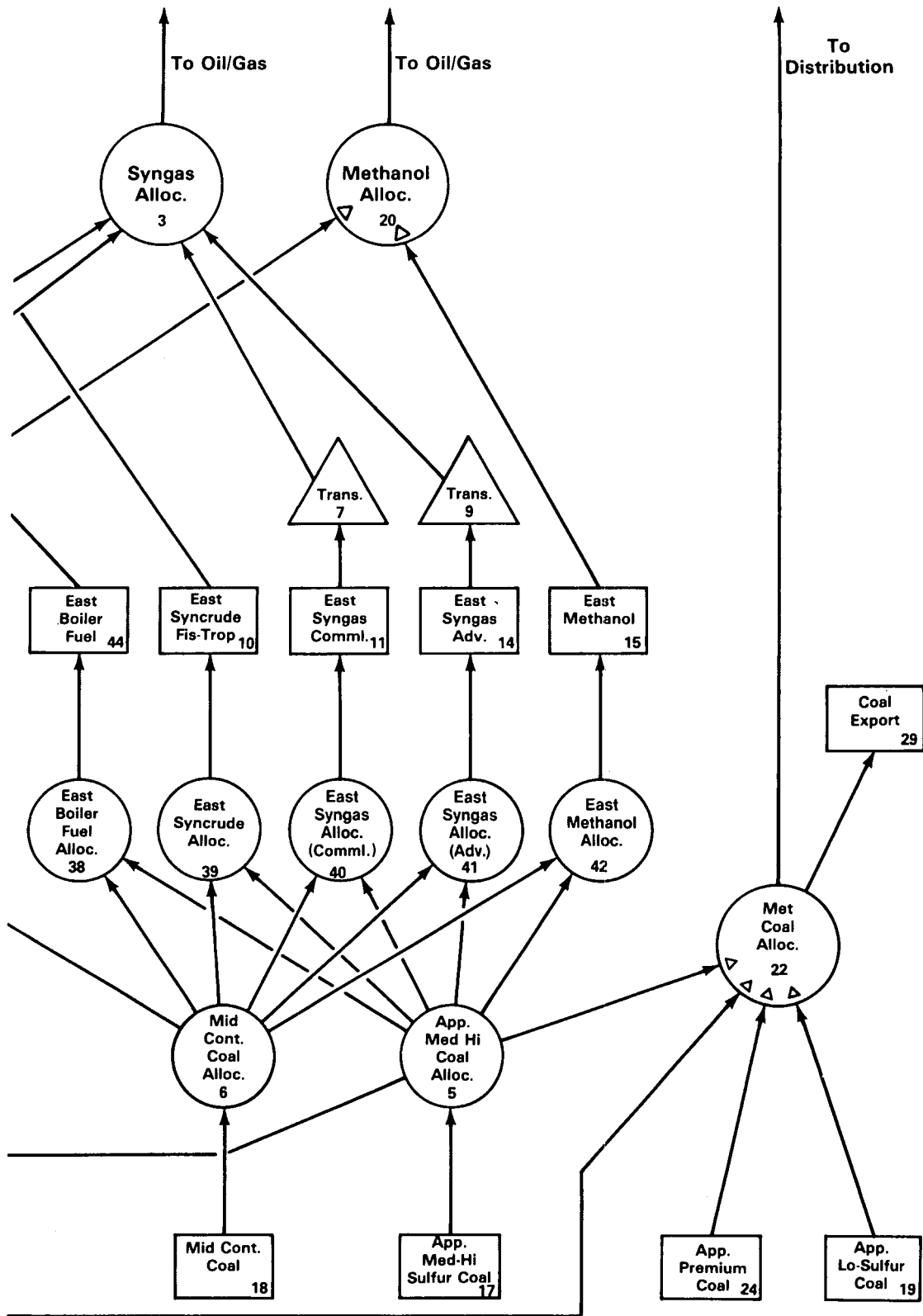
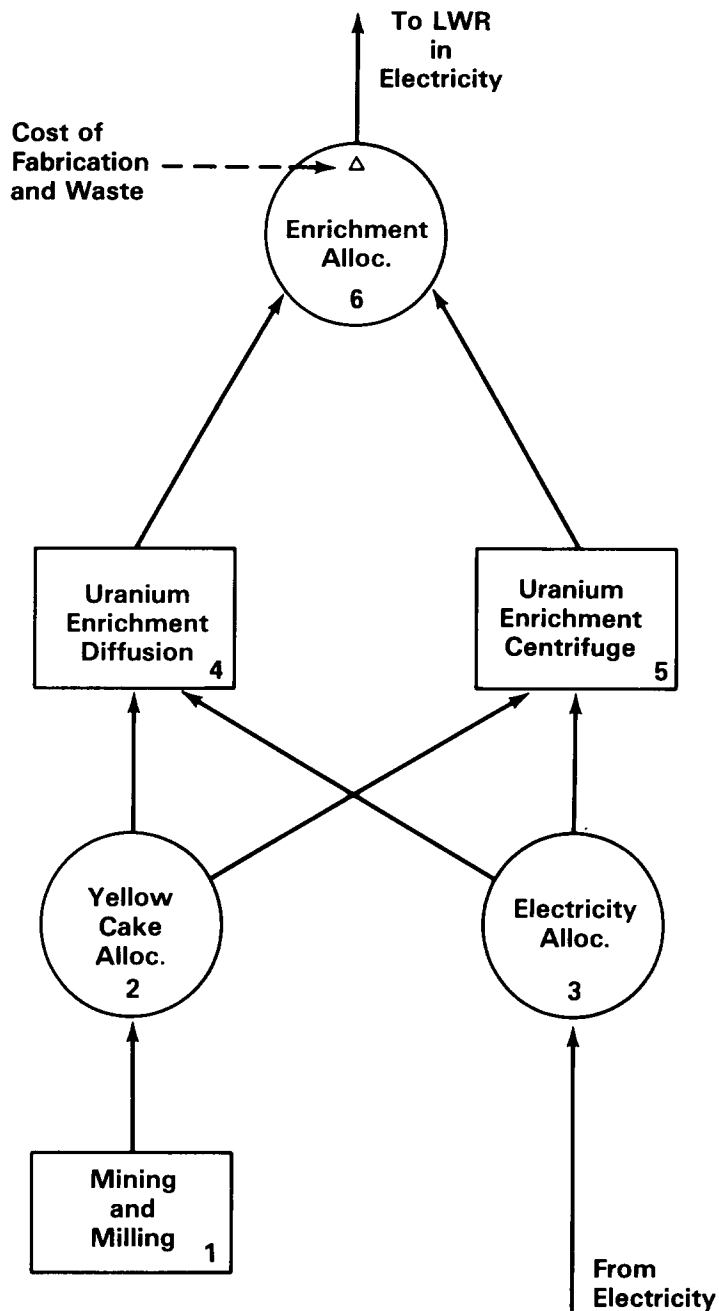

Figure A.4i Coal Sector (Continued)



**Figure A.4j Nuclear Sector**

light trucks for personal transportation and heavy trucks for freight movements. Electric vehicles and conventional automobiles are considered individually.

- **Distribution Sector**—The distribution sector describes the distribution of primary energy supply to the four end-use consumption sectors listed above and to the electric utilities sector. The fuels entering this sector are light oil, heavy oil, liquefied petroleum gas, natural

gas, electricity, coal, metallurgical coal, biomass, and geothermal energy.

- **Electric Utilities Sector**—This sector represents the generation of electricity from nuclear fuel, coal, oil, and gas, as well as renewable sources including solar, wind, ocean thermal energy conversion (OTEC), biomass, and geothermal. Because electricity usage fluctuates, three load categories are represented. Total demand for electricity is disaggregated to the

various load categories in the electric power loading process at the top of this sector. For each load category, the electric allocation process allocates electric demand to the various technologies. Because the economics of each technology are different for each load category, the allocation of demand will also differ by load category.

- **Oil and Gas Sector**—In the oil and gas sector, synthetics and imports are combined with Alaskan and domestic (Lower-48 States) oil and gas sources. Other sources include shale oil and biomass, as well as enhanced recovery of both oil and gas. Crude oil from various sources is processed at either a light oil or heavy oil refinery and transported to the place of distribution. Refinery losses are considered in this structure. Each oil input represents a range of crude oils differing by quality and source. Refined products, classified as light and heavy oil, are gasoline, jet fuel, distillate, and residual fuel oil.
- **Coal-Synthetics Sector**—The coal sector describes the production of coal in various regions of the country (Western, Appalachian, Midcontinent). Two levels of sulfur content (low sulfur and medium-high sulfur) are modeled in LEAP. Lignite and metallurgical coals are also shown. The coal sector represents the production of both liquid and gaseous synthetic fuels. Coal can be liquefied into a synthetic crude oil or gasified into a product (methane) that is very similar to gas from natural sources. Because coal, oil, and gas transportation costs are quite different from the costs of liquefaction and gasification processes (depending on technology and coal used), separate conversion and transportation processes are provided.
- **Uranium Sector**—The uranium sector consists of the mining, milling, and upgrading of yellow cake nuclear fuel by one of two enrichment processes: diffusion or centrifuge. The use of electricity by enrichment plants is modeled endogenously. Fabrication and waste costs are also represented in this sector.

### **LEAP Algorithm**

The algorithm used to solve the generalized equilibrium model finds the set of prices and quantities that satisfies the physical and behavioral relations embodied in the processes and linkages

defined by the network. Because an explicit solution of the model is usually not possible, iterative techniques are used to adjust prices and quantities successively until a solution is found. Starting with initial estimates of prices and quantities for all energy processes, the LEAP algorithm makes two basic sweeps through the entire network. Tentative prices are computed on the upward sweep (holding quantities constant), and tentative quantities are computed on the downward sweep (holding prices constant). Revised quantities and prices are estimated, and the process is repeated until satisfactory convergence is reached. The resulting equilibrium solution reflects the market imperfections and human behavior that are built into the processes.

### **Other Structural Features**

Additional features of the LEAP process models are listed below.

- Plant capacity is distinguished from actual production. Thus, excess or insufficient capacity can occur in a given industry or throughout a given sector.
- Capacity expansion decisions depend on future prices, current capacity, and financial costs. Forecasts of future prices can be based on various forecasting schemes, which may vary from complete myopia to perfect information. Perfect foresight is assumed in LEAP.
- Capacity of different ages and technologies is distinguished, and technological change depending on time of construction, operation, and age of plant is modeled.
- Plant retirement is modeled as an economic decision based on costs rather than as the result of an arbitrarily fixed plant life.
- A detailed treatment is provided for debt and equity financial flows, income taxes, investment tax credits, property taxes, and depreciation. Profits to equity holders are also calculated.
- The ability to constrain quantities is designed into the system. Constraints are needed to represent regional availability, maximum rates of resource production, financial considerations, and technological availability.
- Load patterns of electric power demand are represented. Powerplants are allocated to various load categories, governed by their technological limitations and costs of genera-

tion. As fuel prices change and new technologies are introduced, electric plants are loaded in a way that tends to minimize the cost of producing electricity.

- Resource depletability is modeled both in

terms of reduced production of existing wells or mines and in terms of increased cost of extraction from new wells or mines as the resource base is committed to production.



# Appendix B

## Assumptions and Intermediate Values

This appendix provides a description of the assumptions and intermediate values used in developing the energy projections presented in this *Annual Report to Congress, 1979*. The material is divided into the following three sections:

- B.1 International Chapter Assumptions
- B.2 Midterm Chapter Assumptions
- B.3 Long-term Chapter Assumptions

A section covering the short-term chapter is not included because the material is presented within that chapter as well as in specific data series and reports referenced in the Bibliography.

The midterm section is divided into two parts. The first part describes the principal assumptions and conventions used in developing this year's *Annual Report*. The assumptions made for last year's report are also presented to facilitate comparison of the two reports. The second part of the midterm section contains an enumeration of the detailed assumptions, parameters, and intermediate values used in developing this year's report. Comparable information for last year's report can be found in the *Annual Report to Congress, 1978*, Volume Three.

The long-term section is divided into three parts, the first consists of more general assumptions, the second includes sectoral assumptions, and the third enumerates the detailed information.

The format of the sections and parts of this Appendix is different from Appendix A; an outline structure has been adopted to facilitate locating specific items of information. For example, midterm assumptions concerning macroeconomic variables can be found in the detailed assumptions part of the midterm section. A section guide to the outline is provided at the beginning of each section to further aid in locating specific items.

### B.1 INTERNATIONAL CHAPTER ASSUMPTIONS

#### Section Guide

World Economic Growth Rates .....	294
World Oil Prices.....	294
OPEC Production Capacity.....	295
U.S. Production, Consumption, and Imports....	295
Policy-Induced Conservation Savings .....	296
Demand Price and Income Elasticities .....	296
Energy Supplies and Supply Elasticities.....	298
Transportation Costs.....	299
Trade Flow Constraints .....	300
Refineries .....	300
Electric Utilities .....	302

## World Economic Growth Rates

World economic growth rates are based on projections of gross domestic product, valued in 1975 dollars at 1975 exchange rates. The U.S. rates are based on economic forecasts developed for EIA by Data Resources, Incorporated (DRI). The non-U.S. Organization for Economic Cooperation and Development (OECD) growth rates are based on the long-term projection TRACKSOL, which was developed using the WEFA/SRI world model. The TRACKSOL projections were adjusted to take into account recent hikes in world oil prices. Rates for the non-OECD countries are from the International Bank for Reconstruction and Development publication, *World Development Report*, 1979.

Growth rates for the midprice scenario, which is also the middle demand scenario, are determined first. Rates for the high-price (demand) case are then determined by increasing the middle-range rates 0.4 percentage points per year for the industrial countries and 0.6 percentage points per year for the developing countries. Similarly, low-price (demand) scenario growth rates are determined by decreasing the middle-range rates for

industrialized and developing countries by 0.4 and 0.2 percentage points per year, respectively. These initial growth rates for all scenarios are then modified by the EIA energy models to take into account the feedback effects of changes in world oil prices on economic growth.

### World Economic Growth Rates: 1977–1995 (Annual Percentage Rate)

Region or Country	World Oil Price and Demand Projection Series		
	High	Middle	Low
OECD			
United States .....	2.6	2.7	2.8
Canada .....	3.7	3.4	3.2
OECD Europe .....	2.8	2.5	2.4
Japan .....	4.5	4.3	4.2
Australia/New Zealand .....	3.6	3.4	3.2
Total OECD .....	3.0	2.9	2.8
OPEC (1975–1995) .....	6.4	5.9	5.8
Other (1975–1995) .....	5.5	5.1	5.1
Free World (1975–1995) .....	3.7	3.6	3.5

## World Oil Prices

World oil price forecasts for the various projection series are expressed in real and in nominal dollars. These prices are derived by using the Oil Market Simulation (OMS) model and are used as input assumptions for the IEES model.

### Projected World Oil Prices (Dollars per Barrel)

Year	Real 1979 Dollars		
	High	Middle	Low
1979 .....	21.53	21.53	21.53
1985 .....	39.00	32.00	27.00
1990 .....	44.00	37.00	27.00
1995 .....	56.00	41.00	27.00
	Nominal Dollars		
1979 .....	21.53	21.53	21.53
1985 .....	64.50	54.50	43.50
1990 .....	102.50	84.00	61.50
1995 .....	170.00	123.50	83.50

## OPEC Production Capacity

Projections of OPEC crude oil and production capacities of natural gas liquids are obtained from the U. S. Department of Energy, International Affairs. A low capacity path is based on the assumption that OPEC will not, or cannot, maintain current capacity levels. Administrative con-

straints are currently being applied by Abu Dhabi, Kuwait, Iran, and Saudi Arabia. The middle case has capacities remaining at about current sustainable levels through 1995. The high-capacity case reflects a production expansion rate approaching limits considered technically feasible.

### OPEC Production Capacity (Million Barrels per Day)

Product and Country	1985			1990			1995		
	Low	Middle	High	Low	Middle	High	Low	Middle	High
Crude Oil									
Algeria.....	0.8	0.8	1.0	0.6	0.7	0.9	0.5	0.6	0.7
Ecuador.....	0.2	0.2	0.2	0.2	0.2	0.2	0.1	0.2	0.2
Gabon.....	0.2	0.2	0.2	0.2	0.2	0.2	0.1	0.2	0.2
Indonesia.....	1.5	1.5	1.9	1.4	1.6	1.8	1.1	1.3	1.5
Iran.....	3.5	4.0	4.5	3.0	4.0	4.5	3.0	4.0	4.5
Iraq.....	3.5	3.8	4.5	3.5	4.0	5.0	3.5	4.5	5.0
Kuwait.....	2.5	2.5	2.8	2.5	2.5	2.7	2.5	2.5	2.7
Libya.....	1.8	2.0	2.3	1.5	2.0	2.3	1.2	1.7	2.3
Nigeria.....	2.0	2.1	2.5	1.8	2.0	2.3	1.8	2.0	2.3
Qatar.....	0.5	0.5	0.5	0.4	0.4	0.5	0.2	0.3	0.4
Saudi Arabia.....	9.5	10.5	12.5	9.5	11.0	12.5	9.5	11.0	12.5
United Arab Emirates.....	2.5	2.5	2.8	2.5	2.5	2.8	2.5	2.5	2.8
Venezuela.....	2.0	2.0	2.3	1.7	2.0	2.3	2.0	2.3	2.5
Total.....	30.5	32.6	38.0	28.8	33.1	38.0	28.0	33.1	37.6
Natural Gas Liquids.....	1.5	1.5	1.8	1.5	1.5	1.8	1.7	1.7	2.2
Grand Total.....	32.0	34.1	39.8	30.3	34.6	39.8	29.7	34.8	39.8

## U.S. Production, Consumption, and Imports

The forecasted production, consumption, and import estimates from the Midterm Energy Fore-

casting System (MEFS) have been used to represent the U.S. energy situation in the IEES.

## Policy-Induced Conservation Savings

Estimates of policy-induced, or nonprice, conservation savings for 1985 and 1990 are based on an analysis prepared for EIA by Resource Planning Associates, Incorporated. The 1995 estimates are derived through extrapolation of the earlier year

estimates. Nonprice savings in energy consumption resulting from specified conservation programs are computed in percentage differences from reference case demands.

### Policy-Induced Final Consumption Savings: Middle Scenario (Trillion Btu)

Sector	Canada			Japan			Western Europe		
	1985	1990	1995	1985	1990	1995	1985	1990	1995
Transportation.....	232	316	465	209	269	371	377	465	608
Industrial.....	63	0	0	397	543	811	576	854	1,332
Residential/Commercial..	324	467	608	383	790	1,494	685	931	1,331
Total Savings .....	619	783	1,073	989	1,602	2,676	1,638	2,250	3,271
Total Final Consumption	7,400	8,100	9,100	14,900	17,900	22,200	41,300	43,800	48,400

## Demand Price and Income Elasticities

Quantity forecasts, generated by the OECD energy demand model, are accompanied by associated own-price, cross-price, and income elasticity estimates. These elasticities help define the demand element of the IEES supply-demand integrating mechanism. Elasticities measure the percentage change in the quantity of the energy product demanded, with a percentage change only

in price or income. Cross-price elasticities indicate the percent change in the quantity demanded of one fuel given a percent change in the price of another fuel. The cross-price elasticities presented for Western Europe are representative of those for other industrialized countries. Elasticities are assumed to be relatively constant across scenarios.

### Own-Price Elasticities

OECD Region	Gasoline			Distillate			Residual		
	1985	1990	1995	1985	1990	1995	1985	1990	1995
Austria/Switzerland .....	-0.3	-0.4	-0.6	-0.5	-0.5	-0.5	-0.3	-0.4	-0.4
Benelux/Denmark .....	-0.3	-0.4	-0.6	-0.5	-0.6	-0.6	-0.6	-0.7	-0.7
Canada .....	-0.3	-0.6	-0.7	-0.4	-0.5	-0.5	-0.4	-0.5	-0.5
Finland/Norway/Sweden .....	-0.3	-0.4	-0.6	-0.3	-0.4	-0.4	-0.4	-0.4	-0.4
France .....	-0.3	-0.4	-0.5	-0.5	-0.6	-0.6	-0.4	-0.5	-0.5
Greece/Turkey .....	-0.4	-0.6	-0.7	-0.1	-0.2	-0.2	-0.1	-0.2	-0.2
Italy .....	-0.2	-0.3	-0.4	-0.2	-0.3	-0.3	-0.2	-0.2	-0.2
Japan .....	-0.3	-0.4	-0.5	-0.3	-0.3	-0.4	-0.5	-0.5	-0.5
Spain/Portugal .....	-0.2	-0.4	-0.5	-0.1	-0.1	-0.2	-0.1	-0.2	-0.2
United Kingdom/Ireland .....	-0.4	-0.5	-0.6	-0.4	-0.4	-0.5	-0.4	-0.5	-0.5
West Germany .....	-0.3	-0.5	-0.6	-0.4	-0.5	-0.5	-0.4	-0.4	-0.4

**West European Own-Price and Cross-Price Elasticities  
(Percent)**

Energy Source	Coal	Residual	LPG	Gas	Electricity
<b>Manufacturing Sector</b>					
<b>1978</b>					
Coal.....	-1.22	0.24	0.05	0.15	0.52
Residual.....	0	-0.12	0.00	0.01	0.02
LPG.....	0	0.06	-0.14	0.01	0.07
Gas.....	0	0.02	0.00	-0.16	0.06
Electricity.....	0	0.03	0.00	0.02	-0.13
<b>1985</b>					
Coal.....	-1.14	0.24	0.06	0.15	0.51
Residual.....	0.01	-0.30	0.01	0.03	0.10
LPG.....	0.03	0.12	-0.32	0.04	0.22
Gas.....	0.02	0.06	0.01	-0.38	0.17
Electricity.....	0.02	0.08	0.02	0.05	-0.28
<b>1990</b>					
Coal.....	-1.15	0.24	0.08	0.15	0.52
Residual.....	0.01	-0.34	0.02	0.04	0.13
LPG.....	0.04	0.11	-0.34	0.05	0.23
Gas.....	0.02	0.07	0.02	-0.44	0.20
Electricity.....	0.02	0.09	0.03	0.06	-0.31
<b>1995</b>					
Coal.....	-1.16	0.24	0.09	0.15	0.53
Residual.....	0.01	-0.36	0.02	0.04	0.14
LPG.....	0.04	0.10	-0.38	0.06	0.23
Gas.....	0.02	0.08	0.03	-0.46	0.22
Electricity.....	0.02	0.10	0.03	0.06	-0.32
<b>Residential and Commercial Sector</b>					
<b>1978</b>					
Coal.....	-0.56	0.24	0.02	0.10	0.46
Distillate.....	0	-0.21	0	0.02	0.07
LPG.....	0	0.14	-0.36	0.03	0.15
Gas.....	0	0.02	0	-0.11	0.04
Electricity.....	0	0.06	0	0.02	-0.17
<b>1985</b>					
Coal.....	-0.56	0.22	0.01	0.13	0.47
Distillate.....	0.01	-0.57	0.02	0.05	0.22
LPG.....	0.01	0.32	-0.74	0.07	0.32
Gas.....	0.02	0.13	0.01	-0.38	0.16
Electricity.....	0.01	0.13	0.01	0.04	-0.33
<b>1990</b>					
Coal.....	-0.56	0.22	0.01	0.12	0.48
Distillate.....	0.02	-0.66	0.03	0.07	0.27
LPG.....	0.02	0.36	-0.88	0.09	0.36
Gas.....	0.02	0.21	0.02	-0.50	0.21
Electricity.....	0.01	0.14	0.01	0.04	-0.36
<b>1995</b>					
Coal.....	-0.56	0.22	0.02	0.12	0.48
Distillate.....	0.02	-0.71	0.04	0.08	0.29
LPG.....	0.02	0.39	-0.99	0.10	0.37
Gas.....	0.02	0.26	0.03	-0.58	0.23
Electricity.....	0.01	0.15	0.01	0.05	-0.38

## Income Elasticities

Sector	Canada				Japan				Western Europe			
	1978	1985	1990	1995	1978	1985	1990	1995	1978	1985	1990	1995
Transportation.....	0.66	1.00	1.12	1.21	1.00	1.01	1.07	1.12	0.70	0.79	0.86	0.92
Gasoline.....	0.52	0.84	0.93	0.98	0.52	0.84	0.93	0.98	0.52	0.84	0.93	0.98
Iron and Steel.....	0.57	0.67	0.68	0.68	0.83	0.92	0.94	0.96	0.77	0.87	0.89	0.89
Manufacturing.....	0.16	0.48	0.57	0.61	0.17	0.50	0.58	0.62	0.45	0.80	0.85	0.90
Residential/Commercial.....	0.89	0.96	0.97	0.98	0.59	0.97	1.04	1.09	0.51	0.92	0.99	1.07
Total Final Demand.....	0.63	0.83	0.88	0.91	0.57	0.82	0.90	0.96	0.58	0.85	0.91	0.96

## Energy Supplies and Supply Elasticities

### Crude Oil and Natural Gas Liquids

Supply estimates for crude oil and natural gas liquids are provided at constant world prices by the U.S. Department of Energy's Office of Interna-

tional Affairs. These estimates are the latest projections of free world oil production. The estimates are modified by EIA to reflect higher price scenarios.

### Production of Crude Oil and Natural Gas Liquids (Million Barrels per Day)

Region or Country	1985			1990			1995		
	Low	Middle	High	Low	Middle	High	Low	Middle	High
<b>Non-OPEC</b>									
Mexico.....	3.0	3.5	4.0	3.5	4.0	5.0	4.0	5.0	6.0
Other South America.....	1.7	1.9	2.1	2.0	2.3	2.5	2.5	3.0	3.5
Africa.....	1.5	1.7	1.9	1.6	1.8	3.0	2.0	2.3	3.5
Asia/ Middle East.....	1.6	1.9	2.3	1.7	2.2	2.4	2.4	2.7	3.0
Canada.....	1.4	1.5	1.6	1.5	1.6	1.7	1.6	1.7	1.8
North Sea.....	2.7	3.2	3.6	3.0	3.5	4.0	2.5	3.4	3.8
Other Europe.....	0.4	0.4	0.5	0.4	0.5	0.6	0.3	0.5	0.7
Australia/Japan.....	0.4	0.5	0.5	0.4	0.5	0.6	0.3	0.5	0.7
<b>OPEC</b> .....	29.9	33.0	36.8	28.8	33.1	38.4	28.9	33.7	38.7
<b>Total Free World</b> .....	42.6	47.6	53.3	42.9	49.5	58.2	44.5	52.8	61.7

### Coal

Coal production/export projections are estimates compiled by ICF, Incorporated for selected countries for 1985, 1990, and 1995. These estimates have been categorized into steam and metallurgical coal. The estimates pertaining to the period beyond 1985 are quite uncertain, because of a lack of specific plans on mine development and various political factors in individual countries.

### Supply-Price Elasticities

Insufficient data are available with which to calculate the price elasticity of oil. An elasticity of 0.1 has been used for 1985 in all scenarios and 0.2

for 1990 and 1995 in all scenarios. For oil supplies, price increments in the step of \$1.00 have been used in calculating the supply function.

For coal and natural gas, an elasticity of 0.1 has been assumed for all years and all scenarios. Price increments used to calculate the supply functions are different for natural gas and various types of coal.

Fuel	Price Increments
Natural gas OECD	\$ 0.25
Natural gas non-OECD	0.10
Hard coal	10.00
Brown coal	5.00
Metallurgical coal	10.00

## Transportation Costs

### Crude Oil and Refined Products

The costs of transportation of crude oil and refined products are based on "Average Freight Rate Assessments" (AFRA), determined for each size category of tankers. The AFRA rates are compiled by H. P. Drewry Ltd. and are expressed as a percentage of the "worldscale" rates for each trade route in the world. The "worldscale" rate, compiled by the Association of Ship Brokers and Agents, represents the ratio of the current spot rate on a particular route to the base rate on that route, expressed as a percentage.

The transportation charges of imported crudes

to the United States are based on a weighted mix generated from various tanker sizes. (Tanker size is dependent on the capacity of the ports of origin and destination.) The charges for the east, gulf, and west coasts are calculated on port-to-port distances and other associated costs. The weighted average to the United States is derived from the actual import volumes at these coasts.

### Coal

The transportation costs associated with shipments of coal on oceangoing vessels are estimated by EIA based on Bureau of Mines data.

**Transportation Charges of Imported Crudes to the United States**  
(1979 U.S. Dollars per Barrel)

Originating Country	Type of Crude and API Gravity	East Coast	Gulf Coast	West Coast	Weighted U.S. Average
Algeria .....	Saharan 44°	0.906	1.356	2.216	1.190
Brunei.....	Seria 36.5°	3.203	3.613	2.272	2.936
Canada .....	Canada Heavy 22°	0.660	1.121	2.065	1.030
Ecuador .....	Oriente 30°	1.019	0.904	0.868	0.910
Gabon .....	Mandji 29.6°	1.249	1.634	2.319	1.507
Indonesia .....	Minas 34°	2.759	3.046	1.498	2.113
Iran .....	Iranian Light 34°	2.179	2.731	2.270	2.499
Iraq .....	Basrah Light 35°	2.200	2.755	2.289	2.755
Kuwait .....	Kuwait Blend 31°	2.200	2.755	2.289	2.755
Libya.....	Es Sider 37°	1.132	1.605	2.419	1.449
Malaysia .....	Miri 38°	3.203	3.613	2.272	2.936
Mexico.....	Isthmus 34°	0.776	0.437	1.695	0.440
Nigeria .....	Bonny Light 37°	1.249	1.634	2.319	1.507
Norway .....	Ekofisk 42°	0.788	1.238	2.252	1.139
Oman .....	Oman 36°	3.203	3.613	2.272	2.936
Qatar .....	Dukhan 40°	2.160	2.711	2.253	2.535
Saudi Arabia .....	Arabian Light 34°	2.175	2.727	2.266	2.540
Saudi Arabia .....	Saudi Berri 39°	2.175	2.727	2.266	2.540
Syria .....	Suwaidiyah 25°	1.269	1.757	2.543	1.757
U.A.E.....	Murban 39°	2.160	2.711	2.253	2.535
United Kingdom .....	Forties 36.5°	0.788	1.238	2.252	1.139
U.S.S.R. ....	Kinskaya 32.4°	1.698	2.110	2.963	2.110
Venezuela .....	Tia Juana 26°	0.763	0.806	1.486	0.768
Weighted Average Transportation Cost of All Imported Crudes to United States:					1.610

## Trade Flow Constraints

### Crude Oil

No constraints are imposed on crude oil flows between IEES regions, with the exception of pipeline capacities.

### Refined Products

Refined products trade is constrained not to exceed the actual 1978 trade shares between any two countries or regions.

### Liquefied Natural Gas (LNG)

The LNG trade is constrained to equal existing long-term contracts and not to exceed current proposed contracts, with the exception of LNG

trade originating in the Persian Gulf, which is unconstrained.

### Coal

Minimum and maximum export constraints by country were provided by ICF, Incorporated under contract to EIA.

### Communist Trade

A range of net export and import assumptions have been used across the various projection scenarios to constrain free world trade with Communist nations.

## Refineries

### Refining Crudes to Petroleum Products

The conversion of specific types of crudes is modeled by the IEES refineries model. This conversion results in six petroleum products: gasoline, residual fuel oil, distillate oil, jet fuel, liquefied gases, and other petroleum products. IEES models refineries in 19 of its 32 regions. These 19 refineries are further categorized into eight regional groupings: northern Europe, southern Europe, Canada, Japan, the Caribbean, Australia/New Zealand, OPEC, and the less developed countries (LDC's). All the refineries in each of the broader regional groups are assumed to have the same characteristics.

The operation of a refinery is expressed in yield vectors. These vectors identify the conversion of crude oil into refined products by indicating the quantity of each product that can be obtained from a barrel of crude. Average yield relationships are provided for each crude type.

### Refined Product Yields as Fraction of Total Yield

Product	N. Europe	S. Europe	Canada	Japan
Liquefied Gases.....	0.030	0.036	0.077	0.022
Gasoline.....	0.152	0.134	0.332	0.099
Jet Fuel.....	0.038	0.051	0.076	0.094
Distillate.....	0.318	0.235	0.255	0.132
Residual.....	0.296	0.395	0.190	0.437
"Other" Product.....	0.113	0.094	0.011	0.175
Losses.....	0.053	0.055	0.059	0.041
		Australia/ New Zealand	OPEC	LDCs
	Caribbean			
Liquefied Gases.....	0.001	0.001	0.001	0.001
Gasoline.....	0.112	0.370	0.143	0.193
Jet Fuel.....	0.078	0.063	0.086	0.098
Distillate.....	0.103	0.214	0.151	0.225
Residual.....	0.566	0.181	0.453	0.332
"Other" Product.....	0.091	0.088	0.133	0.100
Losses.....	0.050	0.083	0.033	0.051



## Refinery Capacities

Region-specific refinery capacities are aggregated from country-specific capacities found in the "Petroleum Times Survey of Refinery Construction." Capacities take into account existing, under construction, and proposed refineries. All values are factored by 0.93 because capacity typically can achieve a utilization factor of 93 percent. It is assumed that no limit exists for the construction of desulfurization facilities.

## Operating and Construction Costs

Regional, crude-specific costs of operating, constructing new equipment, and blending products are used in the model. Per barrel capital costs for refinery facilities are based on construction-cost estimates and amortization rates.

## Limits on Refinery Capacity (Thousand Barrels per Day)

Region or Country	Crude Distillation	Catalytic Cracker	Reformer
Asian Exporters .....	1,336	34	43
Australia .....	760	147	181
Austria/Switzerland .....	417	17	46
Benelux/Denmark .....	3,352	141	342
Canada .....	2,126	489	393
Caribbean .....	1,777	66	44
France .....	3,517	185	447
Greece/Turkey .....	733	28	48
Iran .....	781	36	60
Italy .....	4,259	243	390
Japan .....	5,552	311	559
Mexico .....	935	149	65
Persian Gulf/Arabic .....	1,457	8	46
Puerto Rico/Virgin Islands .....	1,012	128	226
Scandinavia .....	1,030	11	162
Spain/Portugal .....	1,468	12	193
U.K./Ireland .....	3,070	203	436
Venezuela .....	1,487	50	19
West Germany .....	3,075	139	390

## Refinery Costs (U.S. Dollars per Barrel)

Region or Country	Distillation	Catalytic Crackers	Reformer	Desulfurization	Operating Costs
Asian Exporters .....	0.734	0.920	1.075	2.080	0.450
Australia/New Zealand .....	0.734	0.920	1.075	2.080	0.490
Austria/Switzerland .....	0.680	0.852	0.996	2.080	0.520
Benelux/Denmark .....	0.680	0.852	0.996	2.080	0.520
Canada .....	0.819	1.026	1.200	2.080	0.590
Caribbean .....	0.788	0.987	1.155	2.080	0.570
Iran .....	0.611	0.765	0.894	2.080	0.500
Italy/Greece/Turkey .....	0.699	0.649	0.813	0.951	0.530
Japan .....	0.580	0.726	0.849	2.080	0.530
Mexico .....	0.734	0.920	1.075	2.080	0.490
Persian Gulf/Arabic .....	0.611	0.765	0.894	2.080	0.450
Puerto Rico/Virgin Islands .....	0.788	0.987	1.155	2.080	0.500
Scandinavia .....	0.680	0.852	0.996	2.080	0.570
Spain/Portugal .....	0.649	0.813	0.951	2.080	0.530
U.K./Ireland .....	0.680	0.852	0.996	2.080	0.520
Venezuela .....	0.611	0.765	0.894	2.080	0.500
West Germany/France .....	0.680	0.852	0.996	2.080	0.520

## Blending Relationship

The conversion of one refined product to another allows the flexibility needed to meet demands. The cost involved in this process is assumed to be the difference in product prices plus \$0.05 per barrel. One barrel of product A converts to X barrels of product B, where X is the ratio of the per-unit Btu content of the two products.

## Data for Blending Calculations

Product	Btu Content per Barrel (10 <sup>6</sup> Btu)	Assumed Product Price (U.S. dollars)
Liquefied Gas .....	4.010	\$10.75
Gasoline .....	5.248	16.40
Jet Fuel .....	4.318	14.42
Distillate .....	5.825	14.17
Residual .....	6.287	11.94
Other .....	5.000	15.25

## Electric Utilities

### Capacity

Existing capacities for conventional thermal, hydroelectric, and nuclear generation are obtained from various sources published by the Organization for Economic Cooperation and Development, the European Economic Community (EEC), and individual countries. Planned capacity additions for conventional thermal and hydroelectric plants are obtained from OECD and EEC data as well as individual country data. Nuclear capacity expansion estimates are EIA forecasts.

### Existing Utility Capacity in OECD (Megawatts)

Country	Thermal Capacity	Nuclear Capacity	Hydro Capacity
Australia .....	15,528	—	9,860
Austria .....	3,723	—	6,501
Belgium .....	7,754	11	462
Canada .....	23,910	3,466	39,511
Denmark .....	5,430	—	8
Finland .....	5,670	—	2,100
France .....	24,000	2,900	15,900
Greece .....	3,490	—	1,563
Iceland .....	107.5	—	381.3
Ireland .....	1,511	—	385
Italy .....	20,754	552	14,779
Japan .....	80,817	6,615	24,853
Luxembourg .....	275	—	972
Netherlands .....	11,930	550	—
Norway .....	160	—	16,940
Portugal .....	1,272	—	2,337
Spain .....	19,518	1,079	7,714
Sweden .....	7,763	3,182	13,062
Switzerland .....	590	1,010	10,560
Turkey .....	2,489	—	1,872
United Kingdom .....	67,300	4,300	2,100
United States .....	403,717	39,299	70,830
West Germany .....	53,970	2,290	4,770

## Utilization Rates

Utilization rates are derived from the historical capacity and production data published by the OECD and the EEC.

### Historical Utilization Rates

Country	Thermal			Hydro			Nuclear <sup>a</sup>
	Base	Inter-mediate	Peak	Base	Inter-mediate	Peak	Base
Australia	0.562	0.226	0.086	0.445	0.179	0.068	0.65
Austria	0.535	0.215	0.082	0.424	0.170	0.065	0.65
Belgium	0.589	0.237	0.091	0.029	0.012	0.005	0.65
Canada	0.359	0.144	0.055	0.724	0.291	0.111	0.75
Denmark	0.430	0.173	0.066	0.224	0.090	0.034	0.65
Finland	0.466	0.187	0.072	0.606	0.243	0.093	0.65
France	0.643	0.258	0.099	0.360	0.145	0.055	0.65
Greece	0.615	0.247	0.095	0.161	0.065	0.025	0.65
Iceland	0.069	0.028	0.011	0.647	0.260	0.100	0.65
Ireland	0.560	0.225	0.086	0.150	0.060	0.023	0.65
Italy	0.597	0.240	0.092	0.344	0.138	0.053	0.65
Japan	0.647	0.260	0.100	0.478	0.192	0.073	0.65
Luxembourg	0.606	0.243	0.093	0.005	0.002	0.001	0.65
Netherlands	0.483	0.194	0.074	0	0	0	0.65
Norway	0.078	0.031	0.012	0.651	0.261	0.100	0.65
Portugal	0.553	0.222	0.085	0.281	0.113	0.043	0.65
Spain	0.418	0.168	0.064	0.392	0.157	0.060	0.65
Sweden	0.273	0.110	0.042	0.564	0.227	0.087	0.65
Switzerland	0.502	0.202	0.077	0.342	0.137	0.053	0.65
Turkey	0.535	0.215	0.082	0.601	0.241	0.092	0.65
United States <sup>b</sup>	0.65	0.375	0.100	—	—	—	—
United Kingdom	0.458	0.184	0.071	0.205	0.082	0.032	0.65
West Germany	0.571	0.229	0.088	0.286	0.115	0.044	0.65

<sup>a</sup>Nuclear utilization rates are assumed.

<sup>b</sup>Used as a default value where data not available.

### Historical Utility Production

(Gigawatt Hours)

Country	Thermal Production	Nuclear Production	Hydro Production
Australia	64,945	—	32,655
Austria	14,816	—	20,515
Belgium	38,642	45	800
Canada	63,873	16,430	213,108
Denmark	20,775	—	25
Finland	19,671	—	9,470
France	101,800	13,000	56,200
Greece	15,982	—	1,879
Iceland	55	—	1,838
Ireland	6,581	—	713
Italy	92,010	3,840	44,750
Japan	389,320	34,080	88,370
Luxembourg	1,600	—	1,150
Netherlands	47,600	1,400	—
Norway	93	—	82,107
Portugal	5,234	—	4,884
Spain	60,758	7,555	22,508
Sweden	15,802	16,012	54,879
Switzerland	2,206	7,916	26,915
Turkey	9,906	—	8,371
United Kingdom	236,600	28,100	4,600
United States	1,825,007	203,302	294,086
West Germany	248,500	14,300	16,200

## Operating and Construction Costs

Where available, country-specific costs from OECD and EEC data are used. Otherwise, domestic costs obtained from the MEFS are used.

### Utility Costs, by Plant Fuel

Country	At Existing Utilities 1976		For Planned Construction, 1976-1979	
	Operating and Management (mills/kWh)	Capital (annual dollars/kW)	Operating and Management (mills/kWh)	Capital (annual dollars/kW)
Coal				
Australia .....	2.20	52.71	2.20	105.42
Austria .....	3.57	54.34	3.57	108.67
Belgium .....	2.30	53.42	2.30	106.84
Canada .....	1.71	47.58	1.71	95.16
Denmark .....	2.30	53.42	2.30	106.84
Finland .....	2.40	54.12	2.40	108.24
France .....	4.04	56.12	4.04	112.23
Greece .....	2.78	52.82	2.78	105.64
Iceland .....	2.40	54.12	2.40	108.24
Ireland .....	2.29	54.29	2.29	108.58
Italy .....	3.10	52.54	3.10	105.09
Japan .....	2.50	51.98	2.50	103.97
Luxembourg .....	2.30	53.42	2.30	106.84
Netherlands .....	2.30	53.42	2.30	106.84
Norway .....	2.40	54.12	2.40	108.24
Portugal .....	2.78	52.82	2.78	105.64
Spain .....	2.78	52.82	2.78	105.64
Sweden .....	2.40	54.12	2.40	108.24
Switzerland .....	3.57	54.34	3.57	108.67
Turkey .....	2.78	52.82	2.78	105.64
United Kingdom .....	2.29	54.29	2.29	108.58
West Germany .....	1.80	54.35	1.80	108.71
Lignite				
Australia .....	2.18	49.95	2.18	99.90
Austria .....	3.57	50.19	3.57	100.38
Belgium .....	2.29	49.98	2.29	99.96
Canada .....	1.71	44.43	1.71	88.85
Denmark .....	2.29	49.98	2.29	99.96
Finland .....	2.40	50.01	2.40	100.02
France .....	4.04	51.90	4.04	103.79
Greece .....	1.88	50.04	1.88	100.08
Iceland .....	2.40	50.01	2.40	100.02
Ireland .....	2.29	50.12	2.29	100.24
Italy .....	3.10	48.48	3.10	96.96
Japan .....	2.50	47.94	2.50	95.87
Luxembourg .....	2.29	49.98	2.29	99.96
Netherlands .....	2.29	49.98	2.29	99.96
Norway .....	2.40	50.01	2.40	100.02
Portugal .....	1.88	50.04	1.88	100.08
Spain .....	1.88	50.04	1.88	100.08
Sweden .....	2.40	50.01	2.40	100.02
Switzerland .....	3.57	50.19	3.57	100.38
Turkey .....	1.88	50.04	1.88	100.08
United Kingdom .....	2.29	50.12	2.29	100.24
West Germany .....	1.70	57.31	1.70	114.62

### Utility Costs, by Plant Fuel (Continued)

Country	At Existing Utilities 1976		For Planned Construction, 1976-1979	
	Operating and Management (mills/kWh)	Capital (annual dollars/kW)	Operating and Management (mills/kWh)	Capital (annual dollars/kW)
Residual Fuel Oil				
Australia .....	1.46	43.96	1.46	87.92
Austria .....	2.14	38.33	2.14	76.65
Belgium .....	1.60	45.14	1.60	90.28
Canada .....	1.32	41.57	1.32	83.13
Denmark .....	1.60	45.14	1.60	90.28
Finland .....	1.73	46.32	1.73	92.64
France .....	2.42	39.82	2.42	79.63
Greece .....	1.66	39.96	1.66	79.92
Iceland .....	1.73	46.32	1.73	92.64
Ireland .....	1.95	54.33	1.95	108.67
Italy .....	1.86	36.84	1.86	73.67
Japan .....	1.18	36.90	1.18	73.80
Luxembourg .....	1.60	45.14	1.60	90.28
Netherlands .....	1.60	45.14	1.60	90.28
Norway .....	1.73	46.32	1.73	92.64
Portugal .....	1.66	39.96	1.66	79.92
Spain .....	1.66	39.96	1.66	79.92
Sweden .....	1.73	46.32	1.73	92.64
Switzerland .....	2.14	38.33	2.14	76.65
Turkey .....	1.66	39.96	1.66	79.92
United Kingdom .....	1.95	54.33	1.95	108.67
West Germany .....	1.08	46.34	1.08	92.68
Crude Oil				
Australia .....	1.46	43.96	1.46	87.92
Austria .....	2.14	38.33	2.14	76.65
Belgium .....	1.60	45.14	1.60	90.28
Canada .....	1.32	41.57	1.32	83.13
Denmark .....	1.60	45.14	1.60	90.28
Finland .....	1.73	46.32	1.73	92.64
France .....	2.42	39.82	2.42	79.63
Greece .....	1.66	39.96	1.66	79.92
Iceland .....	1.73	46.32	1.73	92.64
Ireland .....	1.95	54.33	1.95	108.67
Italy .....	1.86	36.84	1.86	73.67
Japan .....	1.18	36.90	1.18	73.80
Luxembourg .....	1.60	45.14	1.60	90.28
Netherlands .....	1.60	45.14	1.60	90.28
Norway .....	1.73	46.32	1.73	92.64
Portugal .....	1.66	39.96	1.66	79.92
Spain .....	1.66	39.96	1.66	79.92
Sweden .....	1.73	46.32	1.73	92.64
Switzerland .....	2.14	38.33	2.14	76.65
Turkey .....	1.66	39.96	1.66	79.92
United Kingdom .....	1.95	54.33	1.95	108.67
West Germany .....	1.08	46.34	1.08	92.68

### Utility Costs, by Plant Fuel (Continued)

Country	At Existing Utilities 1976		For Planned Construction, 1976-1979	
	Operating and Management (mills/kWh)	Capital (annual dollars/kW)	Operating and Management (mills/kWh)	Capital (annual dollars/kW)
<b>Natural Gas</b>				
Australia .....	0.71	39.05	0.71	78.09
Austria .....	0.72	38.33	0.72	76.65
Belgium .....	0.60	38.53	0.60	77.05
Canada .....	0.50	39.17	0.50	78.34
Denmark .....	0.60	38.53	0.60	77.05
Finland .....	0.50	38.00	0.50	75.99
France .....	0.81	39.82	0.81	79.63
Greece .....	0.81	39.20	0.81	78.41
Iceland .....	0.50	38.00	0.50	75.99
Ireland .....	0.50	37.69	0.50	75.38
Italy .....	0.62	36.84	0.62	73.67
Japan .....	1.18	35.23	1.18	70.46
Luxembourg .....	0.60	38.53	0.60	77.05
Netherlands .....	0.60	38.53	0.60	77.05
Norway .....	0.50	38.00	0.50	75.99
Portugal .....	0.81	39.20	0.81	78.41
Spain .....	0.81	39.20	0.81	78.41
Sweden .....	0.50	38.00	0.50	75.99
Switzerland .....	0.72	38.33	0.72	76.65
Turkey .....	0.81	39.20	0.81	78.41
United Kingdom .....	0.50	37.69	0.50	75.38
West Germany .....	1.04	45.89	1.04	91.78
<b>Blast Furnace Gas</b>				
Australia .....	0.71	39.05	0.71	78.09
Austria .....	0.72	38.33	0.72	76.65
Belgium .....	0.60	38.53	0.60	77.05
Canada .....	0.50	39.17	0.50	78.34
Denmark .....	0.60	38.53	0.60	77.05
Finland .....	0.50	38.00	0.50	75.99
France .....	0.81	39.82	0.81	79.63
Greece .....	0.81	39.21	0.81	78.41
Iceland .....	0.50	38.00	0.50	75.99
Ireland .....	0.50	37.69	0.50	75.38
Italy .....	0.62	36.84	0.62	73.67
Japan .....	0.50	35.23	0.50	70.46
Luxembourg .....	0.60	38.53	0.60	77.05
Netherlands .....	0.60	38.53	0.60	77.05
Norway .....	0.50	38.00	0.50	75.99
Portugal .....	0.81	39.21	0.81	78.41
Spain .....	0.81	39.21	0.81	78.41
Sweden .....	0.50	38.00	0.50	75.99
Switzerland .....	0.72	38.33	0.72	76.65
Turkey .....	0.81	39.21	0.81	78.41
United Kingdom .....	0.50	37.69	0.50	75.38
West Germany .....	1.04	45.89	1.04	91.78

### Utility Costs, by Plant Fuel (Continued)

Country	At Existing Utilities 1976		For Planned Construction, 1976-1979	
	Operating and Management (mills/kWh)	Capital (annual dollars/kW)	Operating and Management (mills/kWh)	Capital (annual dollars/kW)
<b>Distillate Fuel Oil</b>				
Australia .....	2.68	30.87	2.68	61.74
Austria .....	3.92	28.40	3.92	56.81
Belgium .....	2.92	31.38	2.92	62.76
Canada .....	2.03	30.50	2.03	61.00
Denmark .....	2.92	31.38	2.92	62.76
Finland .....	3.17	31.89	3.17	63.77
France .....	4.44	29.71	4.44	59.42
Greece .....	3.05	14.56	3.05	29.13
Iceland .....	3.17	31.89	3.17	63.77
Ireland .....	2.91	35.17	2.91	70.33
Italy .....	3.41	27.10	3.41	54.19
Japan .....	2.16	26.78	2.16	53.56
Luxembourg .....	2.92	31.38	2.92	62.76
Netherlands .....	2.92	31.38	2.92	62.76
Norway .....	3.17	31.89	3.17	63.77
Portugal .....	3.05	14.56	3.05	29.13
Spain .....	3.05	14.56	3.05	29.13
Sweden .....	3.17	31.89	3.17	63.77
Switzerland .....	3.92	28.41	3.92	56.81
Turkey .....	3.05	14.56	3.05	29.13
United Kingdom .....	2.91	35.16	2.91	70.33
West Germany .....	2.31	32.19	2.31	64.37
<b>Nuclear</b>				
Australia .....	—	—	—	—
Austria .....	—	—	8.0	156.8
Belgium .....	—	—	8.2	147.7
Canada .....	—	—	4.3	164.7
Denmark .....	—	—	8.2	147.7
Finland .....	—	—	8.0	173.5
France .....	—	—	8.2	150.5
Greece .....	—	—	—	—
Iceland .....	—	—	8.0	132.3
Ireland .....	—	—	5.0	136.8
Italy .....	—	—	8.3	211.2
Japan .....	—	—	9.5	187.4
Luxembourg .....	—	—	8.2	147.7
Netherlands .....	—	—	8.2	147.7
Norway .....	—	—	8.0	132.3
Portugal .....	—	—	8.2	173.5
Spain .....	—	—	8.2	173.5
Sweden .....	—	—	8.0	132.3
Switzerland .....	—	—	8.0	156.8
Turkey .....	—	—	—	—
United Kingdom .....	—	—	5.0	136.8
West Germany .....	—	—	8.0	171.8

### U.S. Utility Rates<sup>a</sup>

Energy Source	At Existing Utilities 1976		For Planned Construction 1976-79	
	Operating and Management (mills/kWh)	Capital (annual dollars/kWh)	Operating and Management (mills/kWh)	Capital (annual dollars/kWh)
Coal.....	2.5	54.0	2.5	107.9
Lignite.....	2.1	49.9	2.5	99.8
Residual Fuel Oil..	0.9	38.8	0.9	76.6
Crude Oil.....	0.9	38.8	0.9	76.6
Natural Gas.....	0.5	38.8	0.5	76.6
Blast Furnace Gas	0.5	38.8	0.5	76.6
Distillate Fuel Oil..	2.75	28.6	2.75	57.2
Nuclear.....	4.4	58.5	7.3	117.0
Hydro.....	0.80	35.5	0.80	71.0
Geothermal.....	0.80	35.5	0.80	71.0
Thermal (for Multi-fuel Plants).....		54.0	—	107.9

<sup>a</sup>Used as default where data not available.

### U.S. Utility Cost, New Construction

Energy Source	Operation and Management (mills/kWh)		Capital (dollars kW/yr)
	1985		
Nuclear.....	7.50	118.00	
Residual Fuel Oil.....	1.50	76.60	
Crude Oil.....	1.50	76.60	
Coal.....	2.50	107.90	
Lignite.....	2.50	99.80	
Natural Gas.....	0.50	76.60	
Hydro.....	1.55	72.60	
Distillate Fuel Oil.....	2.75	58.40	
1990			
Nuclear.....	7.50	122.40	
Residual Fuel Oil.....	1.50	79.30	
Crude Oil.....	1.50	79.30	
Coal.....	2.50	113.10	
Lignite.....	2.50	104.40	
Natural Gas.....	0.50	79.30	
Hydro.....	1.55	86.20	
Distillate Fuel Oil.....	2.75	59.60	
1995			
Nuclear.....	7.50	122.40	
Residual Fuel Oil.....	1.50	79.30	
Crude Oil.....	1.50	79.30	
Coal.....	2.50	113.10	
Lignite.....	2.50	104.40	
Natural Gas.....	0.50	79.30	
Hydro.....	1.55	86.20	
Distillate Fuel Oil.....	2.75	59.60	

**Relative Utility Cost Factors**  
**(Factor Equals 1, if Cost is Equal to U.S. Cost)**

IEES Region	Thermal		Nuclear		Hydro	
	Operating and Management	Capital	Operating and Management	Capital	Operating and Management	Capital
1985						
C.....	0.86	1.05	0.57	1.40	0.86	1.05
J.....	1.16	0.97	1.27	1.59	1.16	0.97
A.....	1.11	1.11	—	—	1.11	1.11
1.....	1.03	1.15	1.07	1.12	1.03	1.15
2.....	1.08	1.13	0.88	1.37	1.08	1.13
3.....	1.07	1.13	1.09	1.25	1.07	1.13
4.....	1.23	1.20	1.07	1.46	1.23	1.20
5.....	1.76	1.08	1.09	1.28	1.76	1.08
6.....	1.43	1.08	1.07	1.33	1.43	1.08
7.....	1.31	1.07	1.09	1.47	1.31	1.07
8.....	1.25	1.04	1.11	1.79	1.25	1.04
9.....	1.31	1.09	—	—	1.31	1.09
1990						
C.....	0.85	0.97	0.64	1.33	0.85	0.97
J.....	1.13	1.00	1.55	1.82	1.13	1.00
A.....	1.14	1.12	—	—	1.14	1.12
1.....	1.09	1.09	1.33	1.18	1.09	1.09
2.....	1.12	1.25	1.01	1.14	1.12	1.25
3.....	1.12	1.11	1.35	1.39	1.12	1.11
4.....	1.31	1.52	1.33	1.77	1.31	1.52
5.....	1.90	1.13	1.35	1.42	1.90	1.13
6.....	1.59	1.20	1.33	1.49	1.59	1.20
7.....	1.39	1.12	1.35	1.89	1.39	1.12
8.....	1.46	1.16	1.37	2.01	1.46	1.16
9.....	1.48	1.12	—	—	1.48	1.12
1995						
C.....	0.85	0.97	0.67	1.47	0.85	0.97
J.....	1.13	1.00	1.65	2.09	1.13	1.00
A.....	1.14	1.12	1.55	1.61	1.14	1.12
1.....	1.09	1.09	1.48	1.48	1.09	1.09
2.....	1.12	1.25	1.08	1.76	1.12	1.25
3.....	1.12	1.11	1.44	1.63	1.12	1.11
4.....	1.31	1.52	1.48	2.12	1.31	1.52
5.....	1.90	1.13	1.44	1.59	1.90	1.13
6.....	1.59	1.20	1.48	1.69	1.59	1.20
7.....	1.39	1.12	1.44	1.96	1.39	1.12
8.....	1.46	1.16	1.47	1.94	1.46	1.16
9.....	1.48	1.12	1.47	2.28	1.48	1.12

## Thermal Profiles

Thermal profiles project incremental fossil fuel electrical generating capacity in the OECD by IEES region. The source of data is *Steam Coal Prospects to 2000*, International Energy Agency, Paris, 1978. Data represent an average of fossil fuel use in the low- and high-nuclear scenarios for the respective years, 1985, 1990, and 1995 minus an estimate for 1979 use.

### Thermal Profiles

(Million Tons of Coal Equivalent)\*

IEES Region	Hard Coal	Lignite	Residual Fuel Oil	Natural Gas	Crude Oil
1985					
C.....	9.1	—	4.4	2.0	—
J.....	11.7	—	29.8	29.9	29.8
A.....	13.4	—	0.4	2.8	—
1.....	0.4	—	2.3	—	—
2.....	16.3	—	2.6	1.4	—
3.....	7.6	—	8.4	0.7	—
4.....	14.1	3.5	8.1	7.6	—
5.....	0.1	—	0.1	0.1	—
6.....	0.1	—	2.2	1.1	—
7.....	3.3	2.8	1.5	—	—
8.....	4.6	—	29.4	—	—
9.....	0.4	9.2	0.6	—	—
1990					
C.....	17.6	—	4.4	3.2	—
J.....	33.6	—	36.3	48.6	36.3
A.....	22.9	—	0.4	4.1	—
1.....	0.7	—	2.3	—	—
2.....	25.2	—	6.7	1.7	—
3.....	19.1	—	15.4	0.7	—
4.....	29.4	7.3	8.1	9.3	—
5.....	3.6	—	0.1	0.1	—
6.....	0.4	—	4.0	1.7	—
7.....	6.0	5.1	2.4	—	—
8.....	9.7	—	43.0	—	—
9.....	0.9	20.4	3.7	—	—
1995					
C.....	25.5	—	5.0	3.9	—
J.....	51.1	—	36.3	52.3	36.3
A.....	39.6	—	0.5	4.4	—
1.....	3.0	—	3.5	0.1	—
2.....	34.5	—	11.4	1.7	—
3.....	31.1	—	15.7	0.7	—
4.....	46.8	11.7	8.1	9.3	—
5.....	13.5	—	0.1	0.1	—
6.....	0.9	—	4.0	2.2	—
7.....	8.1	6.9	2.4	—	—
8.....	13.1	—	43.0	—	—
9.....	1.2	28.5	7.0	—	—

\*The incremental new builds are in proportion to these numbers.

## B.2 MIDTERM CHAPTER ASSUMPTIONS

### Section Guide

<b>Principal Midterm Assumptions</b> .....	309
All sectors .....	309
Oil .....	310
Gas .....	309
Coal .....	310
Nuclear .....	312
Electric Power .....	313
Residential Sector .....	313
Commercial Sector .....	314
Industrial Sector .....	314
Transportation Sector .....	316
<b>Detailed Midterm Assumptions and Intermediate Values</b> .....	316
Macroeconomic Forecasts .....	316
Estimates of Resources: Oil and Gas .....	319
Outer Continental Shelf (Offshore Lease Sales) .....	320
New Natural Gas: Incremental Pricing .....	320
Old Domestic Natural Gas .....	320
Natural Gas Imports .....	320
Synthetic Natural Gas from Naptha .....	321
International Oil Price .....	321
Oil Industry Costs .....	322
Oil and Gas Transportation Facilities .....	322
Oil, Gas, and Coal Transportation Tariffs .....	322
Mandated Conversions from Oil and Gas .....	323
Coal Supply .....	324
Coal-Fired Powerplant Building Limits .....	324
Electric Generating Plant Capital Costs for New Plants .....	325
Environmental Standards: Scrubbing for Coal-Fired Plants .....	326
Electric Utility Load Factors .....	326
Nuclear Power .....	327
Conservation Programs .....	328
Residential/Commercial Dispersed Technology Program .....	330
Advanced Technology: Maximum Electricity Produced .....	330
Synthetic Fuels: Maximum Quantities .....	331
Price Markups for Major Energy Products .....	331
Price Elasticities (Aggregate) .....	332
Units of Measure .....	333



## Principal Midterm Assumptions

### All Sectors

#### Price Expectations

1978 and 1979 *Annual Report* assumptions:

- Oil Producers—Domestic producers' foresight concerning future price increases is assumed to be quite limited. Producers are assumed not to initiate new projects until they are economically feasible. Rig builders project price growth for the next 6 years based on price increases during the past year; capacity is expanded on that basis.
- Electric Utilities—No price foresight.
- Refineries—No price foresight.

1978 *Annual Report* assumption:

- Industrial decisionmaker has foresight for one-half the life of the project, with constant prices thereafter.

1979 *Annual Report* assumption:

- Industrial decisionmaker has foresight for increases of fuel price over the full life of the project.

#### Depletable Resource Rents

1978 and 1979 *Annual Report* assumption:

- No rents.

#### Financial Costs of Capital

	1978 Annual Report assumption:	1979 Annual Report assumption:
	(percent)	
Industrial Sector	8.00	8.0
Utility Sector	4.28	4.3
Refinery Sector	8.00	8.0
Oil & Gas Drilling	8.00	8.0
Alaskan Oil & Gas	8.00	8.0
Coal	8.00	8.0
New Technologies	8.00	12.0
Enhanced Oil Recovery:		
Steam Drive	10.00	10.0
CO <sub>2</sub> Flooding	10.00	10.0
Surfactant Polymers	10.00	10.0
In-Situ Combustion	20.00	20.0
Polymer Augmented Water Flooding	20.00	20.0

## Oil

### Windfall Profits Tax

1978 *Annual Report* assumption:

- No tax.

1979 *Annual Report* assumptions:

- The law includes a definition for each category of oil, a base price to which tax does not apply, and a tax rate to be applied above the base price.

#### Old Oil (Tier 1 & Tier 2)

- Production of old oil is assumed to be unaffected by the tax.

#### Newly Discovered Oil, Incremental Tertiary, and Heavy Oil

Rate: 30 percent.

Base: \$16.40 plus inflation since second quarter 1979, plus 2-percent real increase per year.

#### Alaskan Oil

- Sadlerochit

Rate: 70 percent.

Base: \$13 plus inflation since second quarter 1979.

- All other oil discovered after 1979 is exempt from Windfall Profits Tax.

### Oil Decontrol

1978 *Annual Report* assumption:

- Abrupt decontrol in 1981.

1979 *Annual Report* assumptions:<sup>1</sup>

- Production from "heavy oil properties" and newly discovered oil on or after June 1, 1979, receives the world market price for crude oil.
- Incremental, new production of crude oil from tertiary recovery projects after June 1, 1979, may receive the world market price.
- Eighty percent of "marginal" crude oil production shifts from the lower-tier to the upper-tier price category on June 1, 1979. The remaining marginal production of crude oil goes to upper-tier on January 1, 1980.

<sup>1</sup> These assumptions are used only to project oil prices in the short-term forecast.

- Lower-tier crude oil is put on a decline rate of 1.5 percent per month, calculated over the 12 months of 1979, and a 3-percent-per-month decline rate starting in January 1980. This allows much of the lower-tier production to receive the higher, upper-tier price and provides for the gradual conversion of most lower-tier crude oil to upper-tier before complete deregulation on October 1, 1981.
- Upper-tier crude oil will also be gradually decontrolled by decreasing a specified percentage of the crude oil production from a property subject to upper-tier price ceilings. From January 1980 to October 1981, 4.6 percent of the amount of crude oil subject to the upper-tier ceiling price would be permitted to be sold in cumulative amounts each month at market prices. To calculate the amount of crude oil subject to the upper-tier ceiling price for a particular month, the volume of crude oil converted from lower-tier status to upper-tier status for the particular month would be included.

### Trans-Alaskan Pipeline

1978 and 1979 *Annual Report* assumption:

- Volume can be expanded to 1.6 million barrels per day by 1985 and to 2.2 million barrels per day by 1990.

### Oil Exports

1978 and 1979 *Annual Report* assumption:

- No oil exports.

### Product Imports

1978 and 1979 *Annual Report* assumption:

- Constrained to encourage domestic refining.

### Pipelines

1978 *Annual Report* assumption:

- PACTEX is the only oil pipeline that connects the West Coast with the midwestern and southwestern pipeline networks.

1979 *Annual Report* assumptions:

- No PACTEX pipeline because SOHIO cancelled the project.

- A Northern-tier pipeline in 1990.
- Ignore the existing small pipeline between California and Texas.

### Refinery Acquisition Cost

1978 and 1979 *Annual Report* assumption:

- Refinery acquisition costs are set at the International Oil Price (IOP) in 1981 with 100-percent cost pass-through.

### West Coast Oil Glut

1978 *Annual Report* assumption:

- No mechanism to eliminate a West Coast oil glut.

1979 *Annual Report* assumption:

- All oil producers of Sadlerochit reservoir continue to ship east at least the same quantities they are now shipping. This assumes that producers on the North Slope desire a secure supply for their own refineries and are willing to forego the increased returns for their oil if it were sold on the West Coast.

## Gas

### Imported Natural Gas

1978 *Annual Report* assumptions:

- Canadian and Mexican imports are priced by a formula that is tied to the IOP. The Canadian price is  $0.155 \times \text{IOP}$  and the Mexican price is  $0.176 \times \text{IOP}$  (dollars per MCF). The delivered price of liquid natural gas (LNG) includes transportation and gasification costs. The estimates are tied to the international oil prices and are based on existing contracts or proposals. Following are the freight-on-board price formulas in 1979 dollars for LNG by project: Distrigas, Trunkline, Tenneco, and El Paso II =  $0.0994 \times \text{IOP} + 0.31$ ; El Paso I =  $0.56 \times \text{IOP}$ ; Pacific Indonesia =  $0.0532 \times \text{IOP} + 1.02$ ; and Columbia =  $0.0545 \times \text{IOP} + .74$ .
- Canadian gas imports lower-bounded at 0.9 Bcf per day in 1985, 0.3 Bcf per day in 1990, and 0.07 Bcf per day in 1995. Distrigas, El Paso II, and Trunkline lower-bounded at capacity.

1979 *Annual Report* assumptions:

- The Columbia and Tenneco LNG projects are deleted. The price formulas were revised as follows. The adjustments are specified in 1979 dollars per Mcf.
- Mexican Gas Border Price Formula:  $0.134 \times \text{IOP}$ .
- Canadian Gas Border Price Formula:  $0.177 \times \text{IOP} - 0.33$ .
- El Paso I Gas FOB Price Formula:  $0.0628 \times \text{IOP} + 0.20$ .
- No lower-bound on Canadian imports. Distri-gas, El Paso I, Trunkline, and Pacific/Indonesia lower-bounded at capacity.

**Alaskan Natural Gas Pipeline**

1978 *Annual Report* assumption:

- Completed by 1985.

1979 *Annual Report* assumption:

- Completed by 1990.

**Incremental Pricing**

1978 *Annual Report* assumptions:

- New, interstate natural gas is incrementally priced above the incremental pricing threshold.
- LNG projects currently operating or pending are not incrementally priced if they are in operation by 1985. Canadian imports beyond 2,750 MMcf per day are incrementally priced. Also, incremental pricing of Canadian and Mexican gas begins at the section 102 ceiling price.
- The alternate fuel cap is set at the Btu-equivalent wholesale distillate price.
- High-priority users: residential, commercial, raw material.
- Low-priority users: industrial.
- Electric utilities and refiners receive marginally priced gas.

	1985	1990	1995
	(1979 dollars per Mcf)		
New Gas Trendline	2.70	3.32	4.07
Incremental Pricing Threshold	1.65	1.67	1.68

1979 *Annual Report* assumptions:

- The assumed treatment of gas purchased by interstate pipelines is the same as in the 1978 *Annual Report*, except that the El Paso I LNG project is incrementally priced.
- High-priority users: residential, commercial, electric utility, raw material.
- Low-priority users: industrial, refinery.
- Utilities in the Southwest pay the marginal cost of gas. All others receive interstate gas at the high-priority price.
- Refineries in the Southwest and on the West Coast pay the marginal cost for gas. All other refineries receive incrementally priced interstate gas.
- Alternate fuel cap is \$0.13 per million Btu (1979 dollars) below the industrial retail price of high-sulfur residual oil in the demand region.

**Coal**

**Rail Rates for Utility Coal**

1978 *Annual Report* assumption:

- All rail rates assume unit-train operations. The 1985 middle case is 15 percent over 1978 rates, but constant thereafter. High and low cases are one standard deviation from the mean. Higher tariffs are used for routes over the Rocky Mountains and in the Northeast Corridor.

1979 *Annual Report* assumption:

- The same as the medium case in the 1978 *Annual Report*.

**Mine-Life and Productivity**

1978 and 1979 *Annual Report* assumption:

- Productivity remains constant for a given set of seam conditions. Assumed life for new mines is 30 years. Assumed life for existing mines is 30 years for both western and eastern mines.

**Industrial Coal Prices**

1978 *Annual Report* assumption:

- Delivered cost of coal is assumed to be \$8.65 per ton (1979 dollars) higher than utility coal in the same demand region.

1979 *Annual Report* assumptions:

- A charge of \$2.60 per ton (1979 dollars) for preparation is added to the cost of all industrial coal.
- Coal supply curves in all regions include adjustments that increase the cost of coal to the industrial market. These adjustments are made to reflect the fact that industrial coal consumers follow different contracting procedures than utilities.
- The rail transportation costs of industrial coal incorporate multicar rates rather than the unit-train rates used for utility coal.

### President's Synfuels Program

1978 and 1979 *Annual Report* assumptions:

- No impact.

## Nuclear

1978 *Annual Report* assumption:

### a. Build Limits

- An industry-average construction time of 82 months is assumed for nuclear generating units not undergoing delays or deferrals. Capacity additions in the middle case through 1995 are limited to 151 GWe above the 48 GWe for existing capacity that will still operate in that year. Some units, which are currently deferred indefinitely, will be reactivated and brought on line by January 1, 1995. In addition, the nuclear industry will receive approximately five net new orders for the next 4 years.

### b. Construction Costs

- Costs for "committed" reactors are taken from EIA data base of utility, architect-engineer, and public utility commission estimates for applicable reactor projects. Costs for "deferrable" and "new" reactors are calculated by the CONCEPT cost accounting code and assume some direct and indirect cost escalation due to resolution of outstanding safety-related issues and more stringent quality-assurance requirements. Costs for midlife repairs and reactor decommissioning by entombment mode are not included in the

baseline capital costs; instead, they are accounted for in the investment decision for new capacity.

### c. Nuclear Fuel Cycle

- The U.S. Government provides adequate enrichment services and spent fuel storage at prices reflective of the Government's cost. All other fuel-cycle services are provided by the private sector at prices determined by prevailing market conditions. The domestic endowment of uranium resources, which is recoverable with current technology, is 3.3 million tons of uranium oxide.

1979 *Annual Report* assumptions:

### a. Build Limits

- An industry-average construction time of 82 months is assumed for nuclear generating units not undergoing delays or deferrals. Capacity additions in the middle case through 1995 are limited to 103 GWe above the 48 GWe for existing capacity that will still operate in that year. Units that are currently deferred indefinitely will not be reactivated and brought on line by January 1, 1995. The nuclear industry will have no net new orders for the next 4 years.

### b. Construction Costs

- Costs for "committed" reactors are taken from EIA data base of utility, architect-engineer, and public utility commission estimates for the applicable reactor projects. Costs for "deferrable" and "new" reactors are calculated by the CONCEPT cost accounting code and assume significant direct and indirect cost escalation because of resolution of outstanding safety-related issues and more stringent quality-assurance requirements. Costs for midlife repairs and reactor decommissioning by dismantlement mode are not included in the baseline capital costs; instead, they are accounted for in the investment decision for new capacity.

### c. Nuclear Fuel Cycle

- These assumptions are the same in the 1979 *Annual Report*, Volume Three, as those in the 1978 *Annual Report*.

## Electric Power

### Environmental Standards

1978 (Series C) and 1979 *Annual Report* assumptions:

- Existing plants are assumed to be in compliance with State Implementation Plans (SIP). Plants currently under construction are assumed to meet the New Source Performance Standards (NSPS) of 1.2 lbs. of sulfur dioxide per million Btu. Plants not currently under construction must meet a revised NSPS of 90-percent sulfur dioxide removal down to 0.6 pounds of sulfur dioxide per million Btu (i.e., partial scrubbing—DOE proposal).
- A scrubbing cost of \$2.45 (1979 dollars) is assumed for each barrel of oil produced through enhanced recovery methods using crude-fired steam generation. Plants are constrained not to increase the current level of sulfur dioxide emissions.

### Load Management

1978 *Annual Report* assumption:

- The base period assumes no impacts from time-of-day pricing. The 1985, 1990, and 1995 estimates include time-of-day pricing impacts at the rate of 0, 1, and 3 percent for the low case; 1, 3, and 5 percent for the middle case; and 2, 4, and 5 percent for the high case.

1979 *Annual Report* assumption:

- No load improvement over the base period is assumed.

### Early Economic Retirements

1978 *Annual Report* assumption:

- Oil plants can be retired before the end of their useful lives and replaced by coal plants if the lifecycle cost comparison indicates that this is economically optimum.

1979 *Annual Report* assumption:

- Capacity expansion in 1985 and 1990 is limited to announced utility plans. Capacity expansion in 1995 is based on economic considerations.

## System Compliance Option

1978 *Annual Report* assumption:

- Utility plants take the systems compliance option. Utility gas use in 1990 is limited to 20 percent of the gas use in the base period (1977), with no use of conventional natural gas by 1995. Docket 600 of the Texas Railroad Commission limits natural gas consumption in Region 6.

1979 *Annual Report* assumption:

- Utilities are permitted unlimited exemptions to burn natural gas. Docket 600 of the Texas Railroad Commission is inoperative. In regions with winter peaks, only half of the existing distillate turbines are allowed to convert to natural gas; no new natural gas turbines can be constructed.

## Residential Sector

### Weatherization Program

1978 *Annual Report* assumption:

- Almost \$500 million in grants are awarded by 1980 as part of the Energy Conservation and Production Act (ECPA) and the National Energy Act (NEA).

1979 *Annual Report* assumption:

- Similar to the 1978 *Annual Report* assumption, except that funding for the program is assumed to continue through 1985 at \$200 million per year.

### Building Standards

1978 *Annual Report* assumption:

- The development of these building standards was legislated under ECPA. Standards that were chosen were estimates of what was thought to be economically and technically feasible.

1979 *Annual Report* assumption:

- Draft standards were promulgated by DOE and published in the *Federal Register* (November 28, 1979). Standards chosen are based on the pending rule and are set by region and building type.

## Appliance Standards

1978 *Annual Report* assumption:

- The development of these standards was legislated by the NEA. The standards that were chosen were estimates of what was thought to be economically and technically feasible.

1979 *Annual Report* assumption:

- The standards that were chosen are based on the energy-efficiency improvement targets published in the *Federal Register* on April 11, 1978, and October 12, 1978.

## Residential Tax Credit and Residential Retrofit Service

1978 *Annual Report* assumption:

- Two million homeowners per year for 8 years participate in these programs. Each homeowner is expected to save 15 million Btu per year.

1979 *Annual Report* assumption:

- It is assumed that between 1978 and 1985, 4 million residents retrofit their homes each year and that between 1986 and 1995, an additional 2 million homeowners retrofit their homes each year. All of the retrofitted homes will increase thermal integrity 10 percent from that in 1970.

## Commercial Sector

### Building Standards

(See Residential Sector.)

### Federal Energy Management Program (FEMP)

1978 and 1979 *Annual Report* assumptions:

- Executive Order 12003 establishes energy-reduction goals of 45 percent for all new buildings and 20 percent for existing building by 1985. These reductions are derived from average levels of consumption per gross square foot of space in 1975.

## Schools and Hospitals

1978 and 1979 *Annual Report* assumptions:

- The NEA establishes a matching grant program of \$900 million for a 3-year period to help public and nonprofit schools and hospitals conserve energy. The funds support preliminary energy audits, detailed energy surveys, and energy-conserving retrofits to existing school and hospital buildings.

## Industrial Sector

### Environmental

1978 *Annual Report* assumptions:

- Post-1981 for boilers greater than 100 million Btu per hour:
  - Low- and high-sulfur coal—Flue Gas Desulfurization (FGD) and Electrostatic Precipitation (ESP)
  - High-sulfur residual oil—FGD and ESP
  - Low-sulfur residual oil—ESP.
- Pre-1982 for boilers greater than 250 million Btu per hour:
  - High-sulfur coal—FGD
  - Low-sulfur coal—ESP
  - High-sulfur residual oil—FGD
  - Low-sulfur residual oil—no control.

1979 *Annual Report* assumptions:

#### a. Existing Plants

- Assumptions cover all plants in the base year (1977). These plants, including all converting units, are subject to the State Implementation Plans (SIP). All existing plants are assumed to be in compliance.

#### b. New Source Performance Standards

- Standards apply to all plants greater than 250 million Btu per hour that commence operation between the base year (1977) and 1985. Any unit constructed between 1972 (the actual year in which NSPS were implemented)

and the base year is assumed to be in compliance with the relevant NSPS:

	Coal	Oil/Gas
	(pounds per million Btu)	
SO <sub>2</sub>	1.20	0.80
TSP	0.10	0.10
NO <sub>x</sub>	0.70	0.70

- All MFBI's greater than or equal to 100 million Btu per hour, but less than 250 million Btu per hour are subject to SIP.
- c. Revised New Source Performance Standards
- Standards will apply to all MFBI's that begin operation after 1985. The actual regulations have not yet been promulgated by the Environmental Protection Agency (EPA) (as of mid-1980). Therefore, the assumptions reflect regulations of RNSPS promulgated in 1978 for electric utilities with less stringent standards for oil and gas boilers.

	Coal	Oil/Gas
	(pounds per million Btu)	
SO <sub>2</sub>	1.2 lbs and 90-percent reduction. If emissions are less than 0.6, a maximum of 70-percent reduction is required.	0.35
TSP	0.03	0.03
NO <sub>x</sub>	0.5/0.6 <sup>a</sup>	0.3/0.15 <sup>c</sup>

<sup>a</sup> 0.5 for subbituminous and 0.6 for bituminous.

<sup>b</sup> 0.35 for residual oil and 0.20 for distillate and natural gas.

<sup>c</sup> 0.30 for residual oil and 0.15 for distillate and natural gas.

### Pollution Control Equipment Assumptions

- a. Sulfur Dioxide (SO<sub>2</sub>)
- Sulfur dioxide is controlled with a limestone wet scrubber. The FGD is assumed to be 90-percent effective with 90-percent reliability.

Thus, overall efficiency for SO<sub>2</sub> control is assumed to be 80 percent. Partial scrubbing is allowed with less than full control met by installing equipment on a portion of the boiler system (i.e., scrubbing a fraction of the total flue gas stream). The FGD unit is also assumed to be capable of removing 90 percent of the coal-fired particulates and 80 percent of the oil-fired particulates when the reliability is 100 percent. Thus, at 90-percent reliability, overall removal efficiencies are 80 percent for coal and 70 percent for oil-fired units.

### b. Total Suspended Particulates (TSP)

- Total Suspended Particulates are controlled by using either an FGD or Baghouse. Baghouses are assumed to have a removal efficiency of 99.5 percent and a reliability factor of 100 percent.

### c. Nitrogen Oxide (NO<sub>x</sub>)

- Oxides of nitrogen are assumed to be controlled through combustion modifications to the boiler (e.g., staged combustion, ammonia injection, or catalytic combustion). The costs for these modifications are assumed to be included in the capital costs of the boiler.

### Powerplant and Industrial Fuel Use Act

1978 and 1979 *Annual Report* assumptions:

- Applicable only to new boilers and existing coal-capable boilers greater than 100 million Btu per hour.
- Environmental exemption: No new coal-fired units can be built in nonattainment areas.

1978 *Annual Report* assumption:

- Economic test: 1.3 ratio with current prices. Exemption permits burning gas or distillate and residual fuels. The "Cost of imported oil" = the least-cost alternative:

a) distillate: capital, O&M, and fuel.

b) residual: capital and O&M (with ESP) and low-sulfur residual fuel.

c) residual: capital, O&M (with FGD and ESP) and high-sulfur residual fuel.

1979 *Annual Report* assumption:

- Economic test: \$2.00 (1979 dollars) premium for oil based on an annuity computed at 7.7 percent from a trajectory in which prices increase annually as follows:

		Oil	Coal
		(percent of increase)	
1981-1990	3	1.5	
1991-2000	1	1.2	
2000-		0.5	1.0

Exemption permits the burning of a non-coal fuel if the cost of that fuel is less than the cost of coal. Cost = the annualized capital + O&M + fuel. Fuel cost for natural gas is treated as if it were the cost of medium-sulfur residual oil.

### Transportation Sector

1978 *Annual Report* assumptions:

- Automotive Fuel Demand: New car fleet efficiency standards are those specified in the Energy Policy and Conservation Act (EPCA) through 1985 and are constant thereafter. Gas-guzzler taxes are those specified in EPCA through 1986. Diesel penetration is assumed to achieve a level of 10 percent of new cars by 1985 and is constant thereafter.
- Light-Duty Truck Fuel Demand: Fuel-efficiency standards are those specified under EPCA through 1981. Efficiency improvements between 1982 and 1985 are trended. Efficiency standards are assumed to be constant after 1985. Diesel penetration is assumed to achieve a level of 10 percent by 1985 and remain constant thereafter.

1979 *Annual Report* assumptions:

- New car efficiency standards remain constant after 1985.
- New light-truck efficiency standards are extrapolated beyond 1982 to 1985.
- New car and light-duty truck efficiencies can exceed standards in response to fuel prices.
- Diesel penetration grows to 10 percent of all new automobile sales and light-duty truck sales in 1985 and remains constant thereafter.

- Diesel on-road efficiency for automobiles is 50 percent greater than gasoline.
- Diesel on-road efficiency for light-duty trucks is 30 percent greater than gasoline.

## DETAILED MIDTERM ASSUMPTIONS AND INTERMEDIATE VALUES

### Macroeconomic Forecasts

The macroeconomic forecasts used for EIA's analysis are all derived from a set of three long-range forecasts for the U.S. economy, which were published by Data Resources, Inc. (DRI) and released in December 1979. The following chart shows their key interrelationships:

DRI Forecasts (December 1979)	Intermediate Forecasts	Final Scenario Impacts	Demand Sensitivity Forecasts
TRENDLONG2004	MEDIOP1	MEDIOPF	—
TRENDLONG2004	HIGHIOP1	HIGHIOPF	—
TRENDLONG2004	LOWIOP1	LOWIOPF	—
HIGHTREND2004	—	—	HIGHDEMAND
LOWTREND2004	—	—	LOWDEMAND

The DRI forecast TRENDLONG2004 was the starting point for each of the three oil price scenarios. This forecast represented DRI's best-informed judgment, at the time of release, as to the likely patterns of U.S. economic activity extended to the year 2004. Initial Midterm Energy Forecasting Systems (MEFS) forecasts for the three cases were based on energy demands that were driven by this forecast. These MEFS solutions were used to create intermediate macroeconomic impact forecasts, MEDIOP1, HIGHIOP1, and LOWIOP1. The intermediate macroeconomic forecasts were, in turn, used to drive the final MEFS runs for middle-, high-, and low-price cases. To conclude the sequence, these MEFS runs were used to create the final macroeconomic impact forecasts, MEDIOPF, HIGHIOPF, and LOWIOPF. This procedure permitted the capture of energy-economy feedbacks. Data are shown in this section of Appendix B for both intermediate and final macroeconomic impact forecasts. Volume Three shows final macroeconomic impact data only.



HIGHDEMAND and LOWDEMAND macroeconomic forecasts were used for the demand sensitivity analysis pertaining to the MEDIOPF case. These forecasts represent modifications of DRI's optimistic and pessimistic economic growth forecasts of December 1979, called HIGHTREND2004 and LOWTREND2004. The original DRI forecasts were essentially variations of TRENDLONG2004 (which projected economic growth to be slightly higher, or lower, over the interval to 2004) with the variation in potential Gross National Product (GNP) (potential output given the supply of productive factors) in these DRI projections reaching plus, or minus, 6.4 percent by 1995. The modifications made by EIA to these forecasts incorporated EIA's energy forecast of the final MEFS run for the middle oil price scenario into these two DRI forecasts.

In all cases where DRI's published forecasts were modified to reflect MEFS results (i.e., for MEDIOP1, HIGHIO1, LOWIO1, MEDIOPF, HIGHIOF, LOWIOF, HIGHDEMAND, and LOWDEMAND forecasts), the procedure was to exogenize all energy variables in the DRI macroeconomic model of the United States so that it would reflect MEFS projections and, then, make any other changes to non-energy variables in the model that were required by the assumptions of any particular scenario or sensitivity run.

Initial assumptions for three scenarios (driven by TRENDLONG2004) and assumptions for demand sensitivity runs (driven by HIGHDEMAND and LOWDEMAND) are presented below followed by data for all forecasts:

#### DRI Forecast TRENDLONG2004

##### Assumptions:

- Real Federal expenditures (NIA basis) rise at a compound annual rate of 2.4 percent (1978–95).
- Money supply increases at a compound annual rate of 7.1 percent (1978–95).
- The yield on new high-grade corporate bond issues rises from 8.9 percent (1978) to 10.4 percent (1980) and remains high for several years, not falling below 9.5 percent until late in the forecast (1990–95).
- The Consumer Price Index (CPIU) increases at a compound annual rate of 8.0 percent (1978–95).

- The labor force increases at a compound annual rate of 1.3 percent (1978–95).
- Real fixed business capital stock increases at a compound annual rate of 3.2 percent (1978–95).
- Productivity increases at a compound annual rate of 1.7 percent (1978–95).
- The GNP deflator increases at a compound annual rate of 7.4 percent (1978–95).

Variables	Growth Rates (compound annual rates of change)			
	1978–80	1980–85	1985–90	1990–95
Real GNP	0.3	3.2	3.2	2.2
Industrial Production				
Index for Total				
Manufacturing	-0.4	5.0	4.2	3.1
Real Disposable				
Personal Income	0.7	3.0	3.3	2.3

#### DRI Model Forecast HIGHDEMAND

##### Assumptions:

- Real Federal expenditures (NIA basis) rise at a compound annual rate of 2.6 percent (1978–95).
- Money supply increases at a compound annual rate of 5.8 percent (1978–95).
- The yield on new high-grade corporate bond issues rises from 9.1 percent (1978) to 10.4 percent (1980) and remains above 9.5 percent for several years (1981–85), before falling to around 8.0 percent (1990–95).
- The CPIU increases at a compound annual rate of 6.9 percent (1978–95).
- The labor force increases at a compound annual rate of 1.5 percent (1978–95).
- Real fixed business capital stock increases at a compound annual rate of 3.8 percent (1978–95).
- Productivity increases at a compound annual rate of 2.0 percent (1978–95).
- The GNP deflator increases at a compound annual rate of 6.2 percent (1978–95).

Variables	Growth Rates (compound annual rate of change)			
	1978-80	1980-85	1985-90	1990-95
Real GNP	0.4	3.5	3.5	2.9
Industrial Production Index for Total Manufacturing	-0.6	5.4	4.8	3.7
Real Disposable Personal Income	0.9	3.5	3.4	2.7

### DRI Model Forecast LOWDEMAND

#### Assumptions:

- Real Federal expenditures (NIA basis) rise at a compound annual rate of 2.1 percent (1978-95).
- Money supply increases at a compound annual rate of 6.6 percent (1978-95).
- The yield on new high-grade corporate bond issues rises from 8.9 percent (1978) to 10.5 percent (1980) and remains above 9.5 for several years (1981-88), before falling to around 9.0 percent (1990-95).
- The CPIU increases at a compound annual rate of 8.0 percent (1978-95).
- The labor force increases at a compound annual rate of 1.2 percent (1978-95).
- Real fixed business capital stock increases at a compound annual rate of 2.8 percent (1978-95). Productivity increases at a compound annual rate of 1.4 percent (1978-95).
- The GNP deflator increases at a compound annual rate of 7.5 percent (1978-95).

Variables	Growth Rates (compound annual rate of change)			
	1978-80	1980-85	1985-90	1990-95
Real GNP	0.3	2.7	2.6	2.1
Industrial Production Index for Total Manufacturing	-0.3	4.3	3.6	2.5
Real Disposable Personal Income	0.7	2.7	2.6	2.0

#### Summary of Macroeconomic Values: Initial Assumptions and Final Scenario Values

The GNP price deflator was used to inflate the GNP estimates from 1972 to 1979 dollars. The

personal consumption price deflator was used to inflate the disposable income estimates from 1972 to 1979 dollars.

	Gross National Product (billions of 1979 dollars)			Industrial Production for Total Manufacturing (1967=1)		
	1985	1990	1995	1985	1990	1995
<b>Initial Assumptions</b>						
TRENDLONG2004	2728	3194	3569	1.860	2.289	2.663
HIGHDEMAND	2775	3296	3797	1.903	2.411	2.886
LOWDEMAND	2660	3022	3346	1.804	2.158	2.440
<b>Intermediate Forecasts (final MEFS assumptions)</b>						
MEDIOP1	2720	3158	3542	1.857	2.281	2.624
HIGHIOP1	2700	3116	3476	1.837	2.239	2.567
LOWIOP1	2737	3202	3627	1.873	2.329	2.996
<b>Final Scenario Values (macroeconomic impacts)</b>						
MEDIOPF	2718	3159	3569	1.855	2.284	2.660
HIGHIOPF	2696	3116	3501	1.835	2.244	2.607
LOWIOPF	2734	3209	3650	1.873	2.344	2.720

	Real (per capita) Disposable Income (thousand 1979 dollars)			Population (annual percent of growth in previous 5 years)		
	1985	1990	1995	1985	1990	1995
<b>Initial Assumptions</b>						
TRENDLONG2004	8.1	9.1	9.8	0.95	0.90	0.69
HIGHDEMAND	8.3	9.3	10.3	0.95	0.90	0.69
LOWDEMAND	7.9	8.6	9.2	0.95	0.90	0.69
<b>Intermediate Forecasts (final MEFS assumptions)</b>						
MEDIOP1	8.1	9.0	9.7	0.95	0.90	0.69
HIGHIOP1	8.0	8.9	9.6	0.95	0.90	0.69
LOWIOP1	8.1	9.0	9.8	0.95	0.90	0.69
<b>Final Scenario Values</b>						
MEDIOPF	8.1	9.0	9.8	0.95	0.90	0.69
HIGHIOPF	8.0	8.9	9.7	0.95	0.90	0.69
LOWIOPF	8.1	9.0	9.9	0.95	0.90	0.69

#### GNP Deflator (1972=1.000), and Conversion Factors for 1975 and 1979 Dollars

All conversions to 1975 and 1979 dollars were based on the relative values of the GNP deflator (1972=1.000) for the appropriate years. All MEFS input values not already in 1975 dollars were converted to 1975 dollars by using appropriate conversion factors. Similarly, MEFS estimates were converted to 1979 dollars for reporting purposes by using the conversion factor 1.302.

Year	GNP Deflator (1972=1.000)	Conversion Factors from 1975 Dollars to Dollars of Year	Conversion Factors from 1979 Dollars to Dollars of Year
1972	1.000	0.787	0.604
1973	1.058	0.832	—
1974	1.160	0.913	—
1975	1.271	1.000	0.768
1976	1.337	1.052	—
1977	1.417	1.115	—
1978	1.520	1.196	—
1979	1.655	1.302	—

### Estimates of Resources: Oil and Gas

#### Oil and Gas Resources (Excluding Enhanced Oil and Gas Recovery and Special Regions)

The U.S. Geological Survey (USGS) estimates of oil and gas undiscovered recoverable resources (Circular 725, with preliminary updates for Alaska, Outer Continental Shelf, and two onshore regions, available January 1980).

Proved reserves are those reported in the API/AGA "Reserves of Crude Oil, Natural Gas Liquids, and Natural Gas in the United States and Canada as of December 31, 1978."

Crude oil reserves are 27.8 billion barrels, natural gas reserves are 200 Tcf, and natural gas liquid reserves are 5.9 billion barrels. Indicated additional crude oil reserves from known reservoirs are 4.3 billion barrels. Inferred reserves of crude oil and natural gas were estimated by using Circular 725, API/AGA data; methodology was developed by M. King Hubbert.

#### Enhanced Oil Recovery

Resource levels input to the Enhanced Oil Recovery Model are estimates (from a sample) of remaining oil-in-place for known oil fields. The sample includes 835 reservoirs selected for their size and applicability of tested or potential recovery method. Estimates include incremental oil recovered by the following methods: steam drive, in situ combustion, chemical flooding, and

gas flooding. The estimates assume that prices are set comparable to the international oil price.

Steam-drive production assumes that lease crude may be burned as fuel. This net production may be increased by burning either distillate fuel oil or incrementally priced natural gas in lieu of lease crude (thereby avoiding scrubbing costs).

A scrubbing cost of \$2.45 (1979 dollars) is assumed for each barrel of oil produced through enhanced recovery methods that use crude-fired steam generation.

#### Special Oil and Gas Regions (Maximum Potential Production)

	1985	1990	1995
Naval Petroleum Reserve (thousands of barrels per day)	175	150	150

Source: DOE Naval Petroleum Reserves Group

**Shale Oil Production.** It is assumed that the low-price scenario is not sufficiently high to generate shale oil production. The medium- and high-price scenarios render shale oil economically feasible, but environmental, technical, and legal obstacles diminish the response of shale oil production to price. Production projections for the middle- and high-price scenarios are judgmentally derived and are based on existing production plans and constraints.

Case	1985	1990	1995
	(thousand barrels per day)		
Low IOP	0	0	0
Medium IOP	9	250	400
High IOP	50	400	600

**Tar Sands (thousands of barrels per day).** Assumes construction decisions will not be made until the IOP reaches \$29.00 per barrel (1979 dollars).

### North Alaska: Production from Prudhoe Bay

	1985	1990	1995
Oil (thousand barrels per day)			
Sadlerochit	1500	923	411
Kuparuk	41	68	57
Lisburne	11	34	34
Total	1552	1025	502
Gas (billion cubic feet per day)	0	2.5	2.5

### Outer Continental Shelf (Offshore Lease Sales)

The 1979-81 values are based on the June 1979 Department of Interior proposed 5-year lease schedule. Estimates thereafter are "best-guess" estimates of DOE's leasing office.

	1979-81	1982-85	1986-90	1991-95
Lower-48 States and Southern Alaska	(acres leased—million acres)			
	5.92	12.70	14.00	13.50
North Alaska (Beaufort Sea)	(number of sales per time interval)			
	1	2	1	1
North Alaska (Chukki Sea)	0	1	1	2

### New Natural Gas: Incremental Pricing

For purposes of incremental pricing, the class of low-priority users is defined to include all industrial users, but excludes those in the raw materials sector. All residential and commercial users, electric utilities, and raw-material feedstock plants are classified as "high priority".

The Distrigas, Trunkline, and Pacific-Indonesian LNG projects are not incrementally priced. However, the El Paso I LNG project is incrementally priced.

	1985	1990	1995
	(1979 dollars per thousand cubic feet)		
Incremental Pricing Threshold	1.81	1.83	1.84

### Old Domestic Natural Gas

The estimates are for old wells that include revisions, but exclude deregulated gas. Interstate prices and quantities are extrapolations of estimates made through 1985 by Foster Associates. Intrastate prices were extrapolated from a report by the Texas Comptroller's Office.

	1985	1990	1995
Interstate			
Price (1979 dollars per thousand cubic feet)	0.87	1.01	1.14
Quantity (trillion cubic feet per year)	4.7	2.5	1.3
Intrastate			
Price (1979 dollars per thousand cubic feet)	1.34	1.51	1.65
Quantity (trillion cubic feet per year)	0.9	0.3	0.2

### Natural Gas Imports

Canadian and Mexican imports are priced by formula and tied to the IOP. The Canadian price is  $0.177 \times \text{IOP} - 0.33$  and the Mexican price is  $0.134 \times \text{IOP}$  (dollars/MCF). The delivered price of LNG includes transportation and regasification costs. Estimates are tied to international oil prices (IOP) based on existing contracts or proposals. The following are the freight-on-board price formulas for LNG by project (dollars/MCF): Distrigas, Trunkline, and El Paso II are  $0.0994 \times \text{IOP} + 0.31$ ; El Paso I is  $0.56 \times \text{IOP}$ ; and Pacific-Indonesia is  $0.0582 \times \text{IOP} + 1.02$ .

### Lower Bound/Upper Bound

	1985	1990	1995
	(trillion cubic feet per year)		
Canadian	0/1.3	0/1.3	0/1.3
Mexican			
High	0/1.2	0/1.2	0/1.2
Middle	0/0.9	0/0.9	0/0.9
Low	0/0.9	0/0.9	0/0.8
LNG	0.8/1.1	0.8/1.1	0.8/1.1

### Transportation, Regasification, and Spur-Pipeline Costs for LNG

Cost estimates are based on submissions to the Economic Regulatory Administration by each respective company.

LNG Project Costs	1985	1990	1995
	(1979 dollars per thousand cubic feet)		
Distrigas	1.60	1.23	0.86
El Paso I	1.44	1.17	0.94
Pacific Indonesia	1.81	1.49	1.26
Trunkline	2.10	1.49	1.08
El Paso II	2.31	1.79	1.43

### Synthetic Natural Gas from Naphtha

Use of synthetic natural gas from naphtha is not economical, even for satisfying peak gas demands. It is assumed that existing plants will produce only insignificant amounts of this fuel.

### International Oil Price (Landed U.S. Price in 1979 Dollars)

International oil prices (IOP) were derived from a general equilibrated representation of world oil markets and world economies with the assumption that OPEC would not be able to produce oil in sufficient quantity to satisfy demand. Prices are therefore increased until the market is cleared.

The domestic wellhead price for newly discovered oil was set at the IOP after January 1, 1979. New enhanced oil recovery is set at the IOP after January 1, 1978. Domestic producer foresight concerning future price increases is assumed to be quite limited. Producers are assumed not to initiate projects until they are economically feasible. Rig builders project price growth for the next 3 years based on price increase during the past year; capacity is expanded on that basis. The IOP for the high, middle, and low scenarios is given in midyear 1979 dollars.

Series	1985	1990	1995
HIGH	39.00	44.00	56.00
MED	32.00	37.00	41.00
LOW	27.00	27.00	27.00

The IOP was derived from the following import supply curves, which were estimated by using EIA's Oil Market Simulation (OMS) Model.

### Response of World Oil Price to the Level of U.S. Crude Oil Imports 1985

Midprice Series		High-Price Series	
Price (1979 dollars)	Imports (MMB/D)	Price (1979 dollars)	Imports (MMB/D)
29.50	0.735	34.50	0.263
30.00	1.469	35.00	0.876
30.50	2.173	35.50	1.470
31.00	2.857	36.00	2.083
31.50	3.531	36.50	2.586
32.00	4.185	37.00	3.119
32.50	4.819	37.50	3.634
33.00	5.444	38.00	4.127
33.50	6.059	38.50	4.610
34.00	6.653	39.00	5.083
34.50	7.237	39.50	5.546
35.00	7.812	40.00	5.997
35.50	8.366	40.50	6.433
36.00	8.921	41.00	6.864
—	—	41.50	7.279
—	—	42.00	7.693
—	—	42.50	8.096
—	—	43.00	8.491

### Response of World Oil Price to the Level of U.S. Crude Oil Imports 1990

Midprice Series		High-Price Series	
Price (1979 dollars)	Imports (MMB/D)	Price (1979 dollars)	Imports (MMB/D)
32.50	0.329	40.00	0.249
33.00	0.930	40.50	0.750
33.50	1.535	41.00	1.240
34.00	2.110	41.50	1.721
34.50	2.695	42.00	2.191
35.00	3.249	42.50	2.640
35.50	3.805	43.00	3.080
36.00	4.349	43.50	3.520
36.50	4.885	44.00	3.940
37.00	5.401	44.50	4.360
37.50	5.925	45.00	4.760
38.00	6.430	45.50	5.161
38.50	6.925	46.00	5.550
39.00	7.421	46.50	5.940
39.50	7.905	47.00	6.315
40.00	8.390	47.50	6.691
40.50	8.513	48.00	7.050
—	—	48.50	7.410
—	—	49.00	7.760
—	—	49.50	8.110
—	—	50.00	8.388

## Response of World Oil Price to the Level of U.S. Crude Oil Imports 1995

Midprice Series		High-Price Series	
Price (1979 dollars)	Imports (MMB/D)	Price (1979 dollars)	Imports (MMB/D)
36.00	0.340	52.00	0.353
36.50	0.858	52.50	0.756
37.00	1.359	53.00	1.149
37.50	1.857	53.50	1.541
38.00	2.347	54.00	1.924
38.50	2.837	54.50	2.297
39.00	3.316	55.00	2.670
39.50	3.786	55.50	3.033
40.00	4.245	56.00	3.383
40.50	4.704	56.50	3.738
41.00	5.153	57.00	4.091
41.50	5.603	57.50	4.429
42.00	6.042	58.00	4.767
42.50	6.482	58.50	5.100
43.00	6.911	59.00	5.423
43.50	7.340	59.50	5.747
44.00	7.760	60.00	6.068
—	—	60.50	6.381
—	—	61.00	6.695
—	—	61.50	6.997
—	—	62.00	7.300
—	—	62.50	7.408

## Oil Industry Costs

Refinery acquisition costs are set at the IOP in 1981 with 100-percent cost passthrough. Refinery fuel cost is determined endogenously.

Heavy crude oil refining cost penalties (1979 dollars) are set at \$0.03 per degree API gravity above 20 degrees and \$0.06 per degree API gravity below 20 degrees.

Assumes no new West-to-East oil or product pipelines, other than the Northern-Tier crude oil pipeline.

### Refinery Investment Costs (1979 Dollars per Barrel per Day of Capacity): \$3,500

### Well Drilling and Equipping Costs

	(1979 dollars per foot)
Oil	48
Gas	67

## Oil and Gas Transportation Facilities (Maximum Potential Flows)

	1985	1990	1995
Trans-Alaska Pipeline (million barrels per day)	1.6	2.2	2.2
Northern-Tier Pipeline (million barrels per day)	0	0.7	0.9
Alaska Natural Gas Transportation System Deliveries of Alaskan Gas (billion cubic feet per day)	0	2.4	2.4

Note: Total shipments of Canadian Gas are handled separately.

## Minimum Deliveries of Alaskan Oil to the East Coast (Thousand Barrels Per Day)

Year	DOE Refinery Region		
1985	25	125	25
1990	25	125	25
1995	25	125	25

## Oil, Gas, and Coal Transportation Tariffs

Tariffs are regionalized to account for variation in transportation costs between regions. The tariffs are adjusted to the target years.

### Pipelines

	1985	1990	1995
	(middle case)		
Trans-Alaskan Pipeline (1979 dollars per barrel)	4.62	4.62	4.62
Alaska Gas Pipeline (1979 dollars per MCF)	—	—	—

Year	DOE Demand Regions									
	1	2	3	4	5	6	7	8	9	10
1985	—	—	—	—	—	—	—	—	—	—
1990	1.85	1.78	1.73	1.58	1.69	1.43	1.69	1.55	1.56	1.33
1995	1.32	1.25	1.20	1.04	1.16	0.90	1.16	1.02	0.92	0.79

	DOE Refinery Region (for all years)		
	2	4	7
Northern-Tier Pipeline (1979 dollars per barrel)	1.21	0.74	0.92

### Railroads

The base case is 15 percent over 1978 rates by 1985, but constant thereafter. Higher tariffs are used for routes over the Rocky Mountains and in the Northeast Corridor.

Fixed Charge	Mileage Charge
(1979 dollars per ton) 2.39	(1979 dollars per ton-mile) 0.0141

### Conversion from Gas to Coal, 1979-84 (Megawatts)

DOE Region	Low-Sulfur Bituminous Unscrubbed
1	—
2	—
3	—
4	—
5	—
6	—
7	240
8	257
9	—
10	—
Total	497

## Mandated Conversions from Oil and Gas (Megawatts)

### 1. Mandated and Proposed Plant Conversions from Oil and Gas to Coal (Megawatts) Pursuant to Authority under the Powerplant and Industrial Fuel Use Act of 1978 (PIFUA)

#### Conversion from Oil to Coal, 1979-84 (Megawatts)

DOE Region	High-Sulfur Bituminous		Low-Sulfur Bituminous
	Scrubbed	Unscrubbed	Unscrubbed
1	400	1756	—
2	2360	1209	1559
3	—	2074	1220
4	—	1758	—
5	—	557	1010
6	—	—	—
7	—	—	—
8	—	—	—
9	—	—	—
10	—	—	—
Total	2760	7354	3789

#### Conversion from Oil to Coal, 1985-89 (Megawatts)

DOE Region	High-Sulfur Bituminous		Low-Sulfur Bituminous	
	Scrubbed	Unscrubbed	Scrubbed	Unscrubbed
1	947	—	442	834
2	1133	—	518	—
3	201	553	166	—
4	—	—	—	—
5	—	—	—	—
6	—	—	—	812
7	—	—	—	—
8	—	—	—	—
9	—	—	—	—
10	—	—	—	—
Total	2281	553	1126	1646

**Conversion from Gas to Coal, 1985-89  
(Megawatts)**

DOE Region	Low-Sulfur Bituminous Unscrubbed
1	—
2	—
3	—
4	—
5	—
6	753
7	85
8	—
9	—
10	—
Total	838

**Oil and Gas to Coal Conversion Capital  
Costs, 1985-90**

These values represent the capital costs associated with expected capacity conversions and are based, in part, on data provided by Teknekron Research, Inc.

DOE Region	High-Sulfur Bituminous		Low-Sulfur Bituminous	
	Scrubbed	Unscrubbed	Scrubbed	Unscrubbed
	(1979 dollars per kilowatt)			
1	329	195	285	195
2	329	195	285	195
3	329	195	285	195
4	344	195	285	195
5	328	195	285	195
6	344	195	284	195
7	344	195	284	195
8	344	195	284	195
9	344	195	284	195
10	344	195	283	195

**Coal Supply**

Productivity remains constant for a given set of seam conditions. The assumed life for new mines is 30 years and the assumed life for existing mines is 30 years for both Western and Eastern mines. The

Federal Surface-Mine Reclamation Act costs are included. Severance taxes are assumed to vary according to current State laws.

The source of this data is the Energy Information Administration's Demonstrated Reserve Base. The midterm supply case excludes unknown quality estimates. Long-term supply case includes unknown quality estimates, which are based on regional average distribution.

**Geology Reserves**

(billion tons)	
Long Term	425
Midterm	322

**Operator Efficiency Factor for Deep Mines**

Efficiency factors are constant over time. These factors relate to the rated capacity as developed by NUS Inc. in the Deep Mines Costing Model developed for the Electric Power Research Institute.

Appalachia	0.65 percent
Midwest	0.75 percent
West	0.85 percent

**Coal Exports**

Year	(million tons per year)		
1985	60	25	85
1990	70	38	108
1995	85	58	143

**Coal-Fired Powerplant Building  
Limits (Megawatts)**

These estimates include committed, deferrable, and new plants. The primary sources for these data are the Federal Power Commission (FPC) 383 reports. No build limits are assumed for 1995.



### Total Coal-Fired Powerplant Built Limit

DOE Region	1979-June 1985	1979-89
	(megawatts)	
1	0	568
2	1,550	2,700
3	5,837	10,562
4	20,877	31,386
5	17,487	24,425
6	25,242	31,172
7	8,986	11,376
8	14,305	21,845
9	3,308	6,720
10	645	645
<b>Total</b>	<b>98,237</b>	<b>141,399</b>

### Electric Generating-Plant Capital Costs for New Plants (1979 Dollars per Kilowatt of Electricity)

The values for coal-fired powerplants are the 1985 national average values and are assumed to be the same as DOE Region V (Chicago-Midwest). The estimates are designed to reflect the cost of the average powerplant for each type delivered on December 31, 1984, and include AFUDC. No real cost escalation in powerplant costs has been assumed for the 1985-95 period. However, the values for nuclear powerplants are developed for each DOE Region and vary by specific MEFS powerplant category. Because of long planning and construction leadtimes, the costs for new reactors are developed as a range of values for operation in the year 1995.

### Fossil-Fueled Powerplants

Fossil-Fueled Powerplants  
(1979 Dollars Per Kilowatt of Electricity)

	Facilities	
	Currently Under Construction	New
Bituminous Coal with Scrubber		
High-sulfur	970	1000
Medium-sulfur	875	940
Low-sulfur	—	930
Bituminous Coal without Scrubber		
Low-sulfur	805	—
Subbituminous Coal with Scrubber		
Medium-sulfur	960	1025
Low-sulfur	—	1015
Subbituminous Coal without Scrubber		
Low-sulfur	885	—
Lignite with Scrubber		
Medium-sulfur	—	1050
Low-sulfur	—	1010
Lignite without Scrubber		
Low-sulfur	885	—
Combined Cycle: distillate	405	405
Simple-Cycle Turbine	175	175
Oil (baseload)	600	600

### Nuclear-Fueled Powerplants

These costs are for committed, deferrable, and new reactors expected to be in commercial operation by 1995.

Committed reactors have 10 percent or more of the construction currently completed. Deferrable reactors are defined as those reactors currently with construction permits, but with less than 10 percent of the construction completed. New reactors are those reactors on order that have currently been docketed for construction permit review with the Nuclear Regulatory Commission and will be potentially available for commercial operation by 1995.

Region 8 has one reactor of small capacity and unique design which is scheduled for commercial operation in 1980. No other new reactors are currently being constructed, are on order, or are planned for Region 8.

The costs anticipated for reactor refurbishment, cleaning, and decommissioning are not included in these figures; they are accounted for in the

MEMM investment calculations for new generating capacity.

Costs for committed reactors are taken from the EIA data base of historic utility, architect/engineer, and public utility commission estimates for applicable reactor projects.

Costs for deferrable and new reactors are derived from the CONCEPT cost-accounting code, which is programmed with the most current data for reactor costs, labor and material rates, and financial assumptions. Additional cost assumptions for each case are as follows:

- Low case—Some basic cost increases are experienced in the future, but construction leadtimes are shortened to 74 months, on average.
- Middle case—Resolution of outstanding safety-related issues and related design uncertainties translate into direct and indirect cost escalation. Construction leadtimes average 82 months.
- High case—Resolution of outstanding safety-related issues translates into significant direct and indirect cost escalation. Construction leadtimes average 96 months.

#### Nuclear Powerplant Capital Costs

MEFS Demand Region	Committed Reactors	1995		
		Deferrable and New Reactors		
		Low	Mid	High
		(1979 dollars per kilowatt-electric of installed capacity)		
1	1290	1155	1285	1505
2	1340	1150	1280	(*)
3	1030	1250	1385	(*)
4	780	945	1045	1275
5	1070	1175	1295	1620
6	795	1030	1150	1415
7	1060	1235	1370	(*)
8	1275	—	—	(*)
9	940	990	1100	1290
10	1400	1305	1570	1985
U.S. Average	990	1065	1185	1420

\*Under assumptions for low supply and associated high costs, no new or deferrable nuclear capacity is forecast for these Regions.

#### Real Cost of Finance (Percent Rate of Return Above Inflation)

The financial structure is assumed to be constant across scenarios at 50 percent for debt, 15 percent for preferred equity, and 35 percent for common equity.

	Base (percent)
Debt	3.0
Preferred Equity	3.5
Common Equity	6.5

#### Environmental Standards: Scrubbing for Coal-fired Powerplants

Existing powerplants are assumed to be in compliance with State Implementation Plans (SIP). Plants currently under construction are assumed to meet the New Source Performance Standards (NSPS) of 1.2 lbs. of sulfur dioxide per million Btu. Powerplants not currently under construction must meet a revised NSPS of 90 percent sulfur dioxide per million Btu removal, unless the emission level is less than 0.6 lbs. of sulfur dioxide per million Btu.

A scrubbing cost of \$2.45 (1979 dollars) is assumed per barrel of oil produced through enhanced recovery methods by using crude-fired steam generation. Powerplants are constrained not to increase their current level of sulfur dioxide emissions.

#### Electric Utility Load Factors: National Average

The 1985, 1990, and 1995 estimates assume no impacts from time-of-day pricing.

Year	Percent
1985	0.626
1990	0.626
1995	0.626

## Nuclear Power: Maximum Addition to Capacity (Gigawatts)

1985 High assumes that (1) utilities perceive an increasing demand for baseload generating capacity; (2) no financial or regulatory difficulties are experienced; and (3) optimistic but not unreasonable construction and licensing leadtimes are assumed (74 months for construction).

1985 Middle assumes that (1) utilities perceive an increasing demand for baseload generating capacity; (2) no financial or regulatory difficulties are experienced; and (3) reactors with construction permits are constructed within 82 months, while second units are completed according to utility assumptions for reactor sequencing.

1985 Low assumes that (1) at the present time, reactors without construction permits will not be in operation in 1985; (2) reactors with construction permits require at least 96 months to construct, while second units are completed according to utility assumptions for reactor sequencing; and (3) a few selected utilities experience financial and/or regulatory difficulties.

1990 High assumes that (1) utilities perceive an increasing demand for baseload generating capacity; (2) no financial or regulatory difficulties are experienced; (3) optimistic but not unreasonable licensing and construction leadtimes are assumed (74 months for construction); (4) capital costs for deferrable and new reactors stabilize by the mid-1980's; and (5) dismantlement decommissioning mode is assumed in the investment decision for deferrable and new reactors.

1990 Middle assumes that (1) utilities perceive an increasing demand for baseload generating capacity; (2) no financial or regulatory difficulties are experienced; (3) at least 82 months are required to construct first units, while second units are completed according to utility assumptions for reactor sequencing; (4) reactors with little or no construction to date experience some additional cost escalation that is attributable to safety-related retrofits and/or design changes; and (5) dismantlement decommissioning mode is assumed in the investment decision for deferrable and new reactors.

1990 Low assumes that (1) only reactors well into the construction-licensing process will be in operation in 1990; (2) at least 96 months are required to construct first units, while second units

are completed according to utility assumptions for reactor sequencing; (3) a few selected utilities experience financial and/or regulatory difficulties; (4) reactors with little or no construction to date experience significant cost escalation that is attributable to safety-related retrofits and/or changes; and (5) dismantlement decommissioning mode is assumed in the investment decision for deferrable and new reactors.

1995 High assumes that (1) no financial or regulatory difficulties are experienced; (2) licensing and construction leadtimes stabilize at pre-1990 levels: first-unit construction leadtime remains at 74 months, while second units are completed according to utility assumptions for reactor sequencing; (3) capital costs for new reactors stabilize during the late 1980's; and (4) dismantlement decommissioning mode is assumed in the investment decision for new reactors.

1995 Middle assumes that (1) few financial or regulatory difficulties are experienced; (2) licensing and construction leadtimes stabilize at pre-1990 levels: first-unit construction leadtime remains at 82 months, while second units are completed according to utility assumptions for reactor sequencing; (3) capital costs for new reactors stabilize during the late 1980's; and (4) dismantlement decommissioning mode is assumed in the investment decision for new reactors.

1995 Low assumes that (1) selected utilities experience licensing and/or regulatory delays; (2) licensing and construction leadtimes continue at pessimistic pre-1990 levels (96 months for construction); (3) significant cost escalation occurs for new reactors as a result of safety-related design changes; and (4) dismantlement decommissioning mode is assumed in the investment decision for new reactors.

These values represent maximum levels of generating capacity to be built by the forecast years. These values are added to the existing 48.11 GWe of capacity as of January 1, 1979, which will not be retired before January 1, of 1985, 1990, or 1995 to determine total capacity by the forecast years.

Case	1985	1990	1995
	(gigawatts of electricity)		
High	51.48	86.53	111.73
Middle	38.35	77.34	102.81
Low	28.99	73.34	87.77

## Conservation Programs

### Residential Sector

**Residential Weatherization.** Almost \$500 million in grants will be awarded by 1980 as part of the National Energy Act (NEA) and the Energy Conservation and Production Act (ECPA). Analysis assumes that funding will continue for 5 additional years, 1981-85, at \$200 million per year.

**Residential Building and Appliance Standards.** These estimates are based on DOE's proposed energy-performance standards for new construction and appliances, as part of the ECPA and the National Energy Conservation Policy Act (NECPA). The appliance improvements are assumed to be implemented by 1985 and impact 100 percent of the covered appliances sold. The standards that have been chosen are based on conversations with representatives of the Office of Conservation and Solar Energy and on to the energy-efficiency improvement targets that were published in the *Federal Register* on April 11, 1978, and on October 12, 1978.

The improvements to new structures are provided by region for each building category. It is assumed that 25 percent, 50 percent, and 100 percent of the buildings built in 1980, 1985, and 1990, respectively, comply with the standards. The standards that have been chosen were based on those in the "Proposed Rule: Energy Performance Standards for New Buildings" published in the *Federal Register* on November 28, 1979.

**Residential Tax Credit and Residential Retrofit Service.** Based on the historical level of retrofitting, the capabilities of the insulation industry, the availability of raw materials needed to allow insulation manufacturers to meet the performance standards and the remaining market for conservation measures, it is assumed that 4 million residents retrofit their homes each year between 1978 and 1985 as a result of these programs and market forces. An additional 2 million individuals retrofit their homes each year between 1986 and 1995 as a result of market forces. Each retrofitted home will improve its thermal integrity by 10 percent, relative to 1970.

### Residential Housing Inventory (Million Units)

Housing	1985	1990	1995
Single family	57.8	61.8	64.9
Multifamily	26.1	28.7	30.4
Mobile home	5.2	6.3	7.2
Total	89.1	96.8	102.5

### Commercial Sector

**Commercial Building Standards.** These estimates are based on DOE's proposed energy performance standards for new construction, as part of ECPA. The assumptions are the same as those for the residential building standards.

**Federal Energy Management Program (FEMP).** Executive Order 12003 establishes energy-reduction goals of 45 percent for all new buildings and 20 percent for existing buildings in 1985. These reductions are from average levels of consumption per gross square foot of space in 1975.

**Schools and Hospitals.** The NEA establishes a 3-year, \$900-million matching grant program to assist public and nonprofit schools and hospitals in the conservation of energy. The funds from this matching-grant program would support four kinds of actions: preliminary energy audits, energy audits, technical assistance (detailed energy surveys), and energy conservation measures (capital investments).

### Commercial Inventory.

Category	1985	1990	1995
	(billion square feet)		
Retail and wholesale	6.6	7.7	8.7
Automotive repair	1.0	1.0	1.1
Office	5.5	6.8	8.2
Warehouse activities	3.6	4.2	4.7
Public administration	1.3	1.4	1.5
Educational services	7.6	8.3	8.9
Hospital and health	2.5	2.7	3.0
Religious	1.6	1.8	1.9
Hotels and motels	2.3	2.7	3.0
Miscellaneous commercial	4.2	4.8	5.4
Total	36.2	41.4	46.4

## Industrial Sector

Three models were used to generate industrial energy-demand forecasts: the industrial sector of the Demand Analysis System (DAS), the Boiler Model integrated within MEFS, and the Industrial Fuel-Choice Analysis Model (IFCAM). Total energy demand, electricity, liquid gas, and feedstocks were determined by the DAS industrial sector. Industrial policy impacts and fuel choice for large (over 100 million Btu per hour) boilers were determined by the integrated MEFS Boiler Model. Policy impacts and fuel choice for small boilers and process heaters were determined by using IFCAM.

**Environmental.** Covers all existing powerplants in base year (1977). These powerplants, including all converting units, are subject to the SIP. All existing units are assumed to be in compliance with SIP.

**New Source Performance Standards.** These standards apply to all powerplants greater than 250 million Btu per hour that commence operation between the base year and 1985. Any unit constructed between 1972 (the actual year NSPS were implemented) and the base year is assumed to be in compliance with the relevant NSPS:

	Coal	Oil/Gas
	(pounds per million Btu)	
SO <sub>2</sub>	1.20	0.80
TSP	0.10	0.10
NO <sub>x</sub>	0.70	0.70

All major fuel burning installations (MFBI) greater than or equal to 100 million Btu per hour, but less than 250 million Btu per hour are subject to SIP.

**Revised New Source Performance Standards (RNSPS).** The revised standards will apply to all MFBI that begin operation after 1985. The actual regulations have not yet been promulgated by EPA (as of mid-1980). Therefore, the assumptions reflect the revised new source performance standards promulgated in 1978 for electric utilities, with somewhat more lax standards for oil and gas boilers.

	Coal	Oil/Gas
	(pounds per million Btu)	
SO <sub>2</sub>	1.2 lbs and 90-percent-reduction. If emissions are less than 0.6, a maximum of 70-percent reduction is required	0.35/0.2 <sup>a</sup>
TSP	0.03	0.03
NO <sub>x</sub>	0.5/0.6 <sup>b</sup>	0.3/0.15 <sup>c</sup>

<sup>a</sup>0.35 for residual oil, 0.20 for distillate and natural gas.

<sup>b</sup>0.5 for subbituminous, 0.6 for bituminous.

<sup>c</sup>0.30 for residual oil, 0.15 for distillate and natural gas.

**Pollution Control Equipment Assumptions.** Sulfur dioxide (SO<sub>2</sub>) is controlled by using a limestone wet scrubber. Flue gas desulfurization (FGD) is assumed to be 90 percent effective with 90 percent reliability. Therefore, overall efficiency for SO<sub>2</sub> control is assumed to be 80 percent. Partial scrubbing is allowed with less than full control met by installing equipment on a portion of the boiler system (i.e., scrubbing a fraction of the total flue gas stream). The FGD unit is also assumed to be capable of removing 90 percent of coal-fired particulates and 80 percent of oil-fired particulates when the reliability is 100 percent. Thus, at 90-percent reliability, overall removal efficiencies are 80 percent and 70 percent for coal and oil-fired units, respectively.

Total Suspended Particulates (TSP) are controlled by using either an FGD or Baghouse. Baghouses are assumed to have a removal efficiency of 99.5 percent and a reliability factor of 100 percent.

Oxides of nitrogen (NO<sub>x</sub>) are assumed to be controlled through combustion modifications (such as, staged combustion, ammonia injection, or catalytic combustion) to the boiler. The costs of these modifications are assumed to be included in the boiler capital costs.

**Powerplant and Industrial Fuel-Use Act.** Applicable only to new boilers and existing coal-capable boilers greater than 100 million Btu per hour. Environmental exemption is included which pro-

hibits construction of new coal-fired units in nonattainment areas.

Economic test: \$2.00 (1979 dollars) premium on oil based on an annuity computed at 7.7 percent from a trajectory in which prices increase annually as follows:

	Oil	Coal
	(percent)	
1981-1990	3.0	1.5
1991-2000	1.0	1.2
2000-	0.5	1.0

An exemption permits the burning of a noncoal fuel if the cost of that fuel is less than the cost of coal. Cost is annualized capital plus operations and maintenance plus fuel. Natural gas fuel cost is treated as if it were the cost of medium-sulfur residual oil.

### Transportation Sector

**Models Used.** The effects of automobile efficiency standards were assessed in the automobile model of the DAS. The effects of light-duty truck efficiency standards and the penetration of diesel engines into both automobiles and light-duty trucks were evaluated with the Light-Duty Vehicle Fuel-Consumption Model. The impacts were then introduced as shifts to DAS results for gasoline and diesel consumption in the transportation sector.

**Automobile.** New car-fleet efficiency standards (EPA measured) are enforced through 1985, as specified in the EPCA. Beyond 1985, efficiency standards would be enforced at 1985 levels. Efficiency may exceed the standards at any time during the forecast period in response to price increases. On-the-road, new-car fuel efficiency is based on air analysis performed by DOE's Policy and Evaluation Office. Purchases of new cars are based on DRI forecasts. Diesel penetration grows to 10 percent of the new automobiles that are sold by 1985 and remains constant thereafter. Diesel on-the-road efficiency is estimated to be 50 percent greater than gasoline.

**Trucks.** Light-duty-truck fuel efficiency standards are in effect, as specified by EPCA, through 1981, and are assumed to grow at a 2.2-percent annual rate until 1985. The 1985 standards are enforced beyond 1985; however, they may be exceeded at any time in response to prices. Light-duty-truck diesel penetration rates reach 10 percent of the new light-duty trucks in 1985 and remain constant thereafter. Diesel on-the-road efficiency is estimated to be 30 percent greater than gasoline for light trucks.

### Residential/Commercial Dispersed Technology Program

Estimates are reductions in demand that are derived from dispersed applications of wind conversion systems, geothermal installation, and solar heating (including hot water) and cooling of buildings. The impacts were based on the research, development, and demonstration, as well as the financial incentive programs of the Federal Government. The financial incentives include the Energy Tax Act of 1978, which provides tax credits to residential and business purchasers of renewable resource systems.

Estimates were derived from penetration rates provided by A. D. Little, Inc., MITRE Corporation, and Science Resources, Inc.

### Advanced Technology: Maximum Electricity Produced (Trillion Btu per Year)

Values represent the level of possible supply available in the target year for the different world oil prices. Private sector capacity and significant Federal Demonstration Projects are included.

	1985		
	High	Middle	Low
Central Electric: AFB	0	0	0
Low- and Medium-Btu Gas:			
Combined-Cycle Baseload	0	0	0
Hydrothermal	71.6	71.6	71.6
Solar	0.9	0.9	0.9
Photovoltaics	0.9	0.9	0.9
Wind	0.9	0.9	0.9
Biomass	11.8	11.8	8.8
Ocean Thermal	0.9	0.9	0.9

	1990		
	High	Middle	Low
Central Electric: AFB	0	0	0
Low- and Medium-Btu Gas:			
Combined-Cycle Baseload	250	0	0
Hydrothermal	98.8	98.8	98.8
Solar	6.8	6.8	6.8
Photovoltaics	6.8	6.8	6.8
Wind	6.8	6.8	6.8
Biomass	29.6	23.7	17.8
Ocean Thermal	5.9	5.9	5.9

	1995		
	High	Middle	Low
Central Electric: AFB	200	100	0
Low- and Medium-Btu Gas:			
Combined-Cycle Baseload	500	250	36
Hydrothermal	119.7	119.7	119.7
Solar	61.4	54.6	44.4
Photovoltaics	54.6	47.8	37.5
Wind	78.5	68.2	54.6
Biomass	53.4	44.5	35.6
Ocean Thermal	38.9	32.8	26.9

### Synthetic Fuels: Maximum Quantities (Trillion Btu)

Values represent the level of possible supply that would be available in the target year for the different international oil prices. Capacity of the private sector and significant Federal Demonstration Projects are included.

	1985		
	High	Middle	Low
Coal Liquids	68	68	68
High-Btu Gas	91	91	91
Medium-Btu Gas	0	0	0
Methanol	0	0	0
Solid Waste Conversion	0	0	0

	1990		
	High	Middle	Low
Coal Liquids	272	68	68
High-Btu Gas	365	365	365
Medium-Btu Gas	340	340	340
Methanol	33	0	0
Solid Waste Conversion	400	266	133

	1995		
	High	Middle	Low
Coal Liquids	952	551	68
High-Btu Gas	913	913	913
Medium-Btu Gas	1328	1182	988
Methanol	130	66	66
Solid Waste Conversion	533	400	266

### Price Markups for Major Energy Products (1979 Dollars per Standard Physical Unit)

The price markups are based on 1975 data and are assumed to increase over time with the rate of inflation. These markups are added to the average fuel prices computed in MEFS to approximate sector-specific fuel prices. The magnitude of the markups reflects differing distribution channels for the delivery of products to final users, as well as any differences in the fuel taxes imposed for each sector.

Fuel/Sector	Demand Region				
	1	2	3	4	5
Natural Gas	(dollars per thousand cubic feet)				
Residential	1.79	1.86	1.40	1.47	1.13
Commercial	1.04	1.17	0.86	0.90	0.75
Industrial	0.38	0.38	0.38	0.38	0.38

	Demand Region				
	6	7	8	9	10
	(dollars per thousand cubic feet)				
Residential	1.33	1.26	1.18	1.42	1.84
Commercial	0.72	0.79	0.93	0.82	1.16
Industrial	0.38	0.38	0.38	0.38	0.38

Distillate	Demand Region				
	1	2	3	4	5
	(dollars per barrel)				
Residential	4.20	4.91	6.05	6.70	3.70
Commercial	2.68	3.25	3.50	3.70	2.48
Industrial	2.61	3.12	4.15	4.20	2.48
Transportation	10.01	10.48	11.48	11.53	9.75

	Demand Region				
	6	7	8	9	10
	(dollars per barrel)				
Residential	4.91	3.38	4.27	4.91	4.91
Commercial	3.25	2.23	2.80	3.06	3.06
Industrial	3.06	3.23	3.00	3.06	3.06
Transportation	10.45	9.56	10.38	10.38	10.38

	Demand Region				
	1	2	3	4	5
Residual	(dollars per barrel)				
Commercial	1.30	1.93	4.06	1.44	2.20
Industrial	1.65	2.61	3.51	1.30	1.99
Transportation	1.65	2.61	3.51	1.30	1.99

	Demand Region				
	6	7	8	9	10
	(dollars per barrel)				
Commercial	1.93	2.34	1.65	1.78	1.30
Industrial	1.93	2.20	1.30	1.72	2.13
Transportation	1.93	2.20	1.30	1.72	2.13

	Demand Region				
	1	2	3	4	5
Liquid Gas	(dollars per barrel)				
Residential	2.72	3.25	4.65	4.65	2.16
Industrial	1.71	2.07	2.99	3.07	1.44

	Demand Region				
	6	7	8	9	10
	(dollars per barrel)				
Residential	2.90	1.97	2.64	2.94	2.94
Industrial	1.93	1.27	1.66	1.84	1.84

	Demand Region				
	1	2	3	4	5
Gasoline	(dollars per barrel)				
Transportation	13.15	14.53	13.15	12.80	12.92

	Demand Region				
	6	7	8	9	10
	(dollars per barrel)				
Transportation	11.83	12.52	12.46	14.02	14.07

	Demand Region				
	1	2	3	4	5
Jet Fuel	(dollars per barrel)				
Transportation	4.15	4.81	6.40	6.83	3.65

	Demand Region				
	6	7	8	9	10
	(dollars per barrel)				
Transportation	4.81	3.29	4.39	4.81	4.81

	Demand Region				
	1	2	3	4	5
Electricity	(mills per kilowatt-hour)				
Residential	5.63	10.04	8.73	4.47	8.67
Commercial	3.93	11.20	4.78	5.34	7.06
Industrial*	-11.28	-21.05	-9.10	-6.24	-9.10

	Demand Region				
	6	7	8	9	10
	(mills per kilowatt-hour)				
Residential	8.59	6.35	7.95	5.19	5.19
Commercial	3.17	3.28	1.30	1.42	5.48
Industrial*	-8.70	10.04	8.40	9.70	6.64

\*Negative values indicate markdowns for industrial users.

### Price Elasticities (Aggregate)

The DAS uses historical data to estimate future fuel demands and the sensitivity of those demands to price changes to develop the appropriate demand curves for use in MEFS. The price elasticities are assumed to be relatively constant across scenarios. The values in a column of the elasticity table indicate the percent change in the quantities consumed for each row fuel in response to a 1-percent change in the price of the column fuel.

Sector/Fuel	1985		
	Electricity	Natural Gas	Distillate
Residential			
Electricity	-0.3266	0.0724	0.0360
Natural Gas	0.0364	-0.2722	0.0032
Distillate	0.0490	0.0078	-0.3688
Sector/Fuel	1990		
	Electricity	Natural Gas	Distillate
Electricity	-0.3664	0.0988	0.0514
Natural Gas	0.0548	-0.3020	0.0044
Distillate	0.0768	0.0108	-0.4574
Sector/Fuel	1995		
	Electricity	Natural Gas	Distillate
Electricity	-0.3826	0.1180	0.0598
Natural Gas	0.0678	-0.3268	0.0058
Distillate	0.0966	0.0146	-0.5340



	1985		
	Electricity	Natural Gas	Oil
Commercial			
Electricity	-0.4424	0.0204	0.0075
Natural Gas	0.0481	-0.3838	0.0183
Oil	0.0306	0.0319	0.4125
	1990		
	Electricity	Natural Gas	Oil
Electricity	-0.4584	0.0245	0.0093
Natural Gas	0.0631	-0.4046	0.0236
Oil	0.0534	0.0548	-0.4483
	1995		
	Electricity	Natural Gas	Oil
Electricity	-0.4760	0.0295	0.0108
Natural Gas	0.0820	-0.4254	0.0286
Oil	0.0931	0.0925	-0.5274

	1985						
	Electricity	Natural Gas	Distillate Fuel Oil	Residual Fuel Oil	Liquid Gas	Coal	
Industrial							
Electricity	-0.3731	0.0431	0.0486	0.0306	0.0353	0.0103	
Natural Gas	0.1032	-0.3890	0.0315	0.0201	0.0211	0.0059	
Distillate Oil	0.2146	0.0425	-0.5336	0.0295	0.0334	0.0084	
Residual Oil	0.0845	-0.0064	0.0345	-0.3556	0.0276	0.0084	
Liquid Gas	0.1518	0.0205	0.0376	0.0233	-0.4485	0.0085	
Coal	0.0793	0.0118	0.0185	0.0130	0.0160	-0.3463	

	1990						
	Electricity	Natural Gas	Distillate Fuel Oil	Residual Fuel Oil	Liquid Gas	Coal	
Electricity	-0.4495	0.0775	0.0579	0.0382	0.0432	0.0124	
Natural Gas	0.1272	-0.4429	0.0367	0.0251	0.0233	0.0066	
Distillate Oil	0.2529	-0.0765	-0.6369	0.0379	0.0397	0.0093	
Residual Oil	0.1289	0.0087	0.0459	-0.4544	0.0358	0.0110	
Liquid Gas	0.1900	0.0457	0.0464	0.0310	-0.5460	0.0105	
Coal	0.0960	0.0243	0.0207	0.0152	0.0184	-0.4000	

	1995						
	Electricity	Natural Gas	Distillate Fuel Oil	Residual Fuel Oil	Liquid Gas	Coal	
Electricity	-0.4882	0.1006	0.0632	0.0408	0.0449	0.0136	
Natural Gas	0.1387	-0.4645	0.0393	0.0260	0.0231	0.0070	
Distillate Oil	0.2702	0.1008	-0.6889	0.0412	0.0412	0.0102	
Residual Oil	0.1587	0.0233	0.0521	-0.5146	0.0384	0.0125	
Liquid Gas	0.2123	0.0632	0.0508	-0.0338	-0.5998	0.0116	
Coal	0.1060	0.0314	0.0216	0.0154	0.0184	-0.4253	

	1985			
	Gasoline	Distillate Oil	Residual Oil	Jet Fuel
Transportation				
Gasoline	-0.2882	0.3722	0	0
Distillate Oil	0.2795	-0.6562	0	0
Residual Oil	0	0.1417	-0.0950	0
Jet Fuel	0	0	0	-0.4205

	1990			
	Gasoline	Distillate Oil	Residual Oil	Jet Fuel
Gasoline	-0.4512	0.2976	0	0
Distillate Oil	0.4467	-0.8887	0	0
Residual Oil	0	0.1406	-0.0914	0
Jet Fuel	0	0	0	-0.5179

	1995			
	Gasoline	Distillate Oil	Residual Oil	Jet Fuel
Gasoline	-0.5578	0.2877	0	0
Distillate Oil	0.5912	-1.0954	0	0
Residual Oil	0	0.1400	-0.0936	0
Jet Fuel	0	0	0	-0.6022

## Units of Measure

### Weight

1 long ton..... contains 1.120 short tons

### Conversion Factors for Crude Oil (Average Gravity) and Natural Gas

1 barrel..... contains 42 gallons

1 barrel..... weighs 0.136 metric tons (0.150 short tons)

1 Mcf..... contains 1,000 cubic feet of gaseous material at standard conditions (14.7 psi and 60°F.)

### Aggregate Heat Content of Petroleum

Crude Oil ..... 5.820 million Btu per barrel

Gasoline..... 5.248 million Btu per barrel

Jet Fuel ..... 5.572 million Btu per barrel

Distillate Fuel Oil..... 5.825 million Btu per barrel

Residual Oil ..... 6.287 million Btu per barrel

### Aggregated Heat Content of Natural Gas

Natural Gas Liquids.... 4.011 million Btu per barrel

Natural Gas..... 1.032 million Btu per Mcf

## Aggregated Heat Content of Coal

Steam coal, average consumption.....	22.5 million Btu per short ton
Steam coal production by rank:	
Bituminous .....	23.80 million Btu per short ton
Midbituminous...	21.80 million Btu per short ton
Subbituminous...	18.33 million Btu per short ton
Lignite.....	13.00 million Btu per short ton
Metallurgical coal, production and consumption.....	27.00 million Btu per short ton
Electricity consumption .....	3,412 Btu per kilowatt-hour

## Electricity Conversion Heat Rates for Existing Plants in Base Mode

Bituminous Coal .....	8,900-12,300 Btu per kilowatt-hour
Subbituminous and Lignite.....	10,400-13,980 Btu per kilowatt-hour
Gas.....	9,800-12,200 Btu per kilowatt-hour
Oil.....	9,700-14,000 Btu per kilowatt-hour
Nuclear Steam-Electric ...	11,000 Btu per kilowatt-hour
Hydroelectric.....	10,389 Btu per kilowatt-hour

Industry Assumptions .....	337
Transportation Assumptions .....	337
Residential Assumptions .....	339
Commercial Assumptions .....	339
Sensitivity Case Assumptions.....	339
<b>Detailed Assumptions</b> .....	340
Financial Assumptions .....	340
Fuel Price Elasticity Assumptions .....	340
Service Demand Elasticity Assumptions.....	340
Coal Export Assumptions.....	341
Electric Generating Plant Specifications .....	341
Synthetic Gas and Liquids Technology Specifications.....	342
End-Use Technology Specifications—Residential .....	342
End-Use Technology Specifications—Commerical .....	343
End-Use Technology Specifications—Industrial.....	343
End-Use Technology Specifications—Transportation .....	344
Upper Bounds on Electricity Generating Output .....	344
Upper Bounds on Synthetic Fuels Production.....	344
Upper Bounds on End-Use Demands .....	344
Upper Bounds on Lignite Coal to Electricity .....	345

## B.3 LONG-TERM CHAPTER ASSUMPTIONS

### Section Guide

<b>General Assumptions</b> .....	334
Concept of the Energy Sector.....	334
Demand for Energy Services.....	335
Resource Supply .....	335
Upper Bounds .....	335
Equilibrium .....	335
Pricing of a Product or Service .....	335
Market Price.....	335
Market Penetration .....	335
Conversion Facility Life.....	336
<b>Sectoral Assumptions</b> .....	336
Utility Electricity Assumptions.....	336
Nuclear Assumptions .....	336
Resource Assumptions.....	337
Transportation and Distribution Costs.....	337

### General Assumptions

#### Concept of the Energy Sector

The energy sector in the long-term analysis is perceived to be a series of national markets for energy products and services, starting with raw materials and ending with energy services provided to final consumers. A market is assumed to exist where significant decisions regarding the source of raw material or choice of technology are made (e.g., a consumer who decides to heat his home with an electric heat pump instead of an oil furnace adds to the demand for electricity). The electric utility decides on the generation technology to provide this electricity, which results in a demand for fuels. The fuel market then must decide what sources of primary energy will be

used. In each market, the decision is based on the cost of obtaining the energy service from alternative sources.

### **Demand for Energy Services**

The long-term projection of the demand for energy services in the middle world oil price case involves several steps:

- The GNP growth rates assumed for the midterm projection are used through 1995; 2.38 percent annually is assumed from 1995 to 2000, and 2 percent annually is assumed from 2000 to 2020.
- The rates of growth of service demands relative to the growth in the GNP are projected in the form of elasticities. These elasticities are applied to the GNP growth rates from 1975 (the base year) to 2000 to yield projected service demands. After 2000, the relationship between service demand and GNP growth can be adjusted based on specific assumptions, which are listed below.
- An assumed long-term price elasticity and a behavioral lag are applied to obtain final long-term service demand projections.
- These projections are adjusted for 1995 to correspond to the midterm projections.

### **Resource Supply**

- **Depletable Resources**—The cost and availability of depletable resources are represented by long-term supply curves. The marginal cost of extraction increases with cumulative commitments to production. The sources and examples of these curves are given in Chapter 5.
- **Renewable Resources**—The cost and availability of these resources are represented by short-term supply curves, in which the costs increase with total annual demand. These curves are based largely on data obtained from various U.S. Department of Energy sources.

### **Upper Bounds**

Maximum production limits for certain activities are assumed for several reasons. Geographically restricted resources are limited to the maximum share of the national market they

can serve. Maximum outputs of crude oil, shale oil, natural gas, synthetics from coal, and new electrical generation technologies are set approximately at the levels projected in the midterm analysis through 1995. Thereafter, outputs are limited by assumed maximum growth rates.

### **Equilibrium**

Simultaneous equilibrium of all energy prices and quantities from 1975 through 2020 in 5-year intervals is obtained, with all markets satisfied at projected prices.

### **Pricing of a Product or Service**

- **Incremental Pricing**—All prices are determined endogenously, based on the long-term incremental cost of new capacity, which is calculated by using the return on equity method of financial analysis.
- **Foresight**—In the calculation of the long-term incremental cost (minimum acceptable price in each year of operation), the present value of future revenues is used, based on the endogenously determined future prices. Therefore, “perfect foresight” of future prices is assumed.
- **Rent**—When new capacity for a depletable resource is required, the owners are assumed to be paid a premium or scarcity rent equal to the present value of the potential gain from delaying production to any future time. The price of the output is increased above the long-term incremental cost to reflect this rent.

### **Market Price**

The national market price is the quantity weighted average price of all the products or services supplying a particular market. (An exception is the market price for crude oil, which is set at the world oil price for all domestic conventional oil.)

### **Market Penetration**

The market process is assumed to be stochastic and represents the uncertainty of actual prices, the diversity of prices in a national market, and the

variations in decision rules used by different buyers.

Differing sources of supply are assumed to have uncertain prices approximated by the Weibull probability density functions. Each supply or technology ultimately captures that percentage of the market corresponding to the probability that it is the cheapest source.

- **Price Dispersion**—The measure of price uncertainty used in this analysis is the dispersion, which is the ratio of the standard deviation to the mean of the price density function. To develop estimates of the dispersion, national distributions of prices have been examined (e.g., the distribution of coal prices to utilities by State). Because, in most cases, a single measure of uncertainty for a market is required, the dispersion is estimated to be the quantity weighted average of the prices of the fuels supplied to the market. The price dispersions developed for the residential market by this procedure average about 0.2, and those of the industrial market are lower, averaging about 0.13. This trend is substantiated by the fact that energy-intensive industries locate near low-cost sources of supply. Colocation flexibility is not feasible for most homeowners.
- **Penetration Rate**—The market share of a product or technology for the current period changes from that of the previous period toward the calculated ultimate share with a specific lag. For continued demand, which is the portion of demand equal to that of the previous period, the lag is related to the capital stock turnover period. For markets that decide on the use of capital intensive technologies, such as electric generation, the lag is significant. For flexible markets, such as the crude oil market, the lag is short. For a new demand, the difference between present and past demand, the lag is generally set at one-third of the continued demand lag. This smaller lag represents the increased flexibility in the choice of new capital stock.

### **Conversion Facility Life**

Energy conversion facilities can range from residential air conditioners to coal conversion plants. Initial production is equal to total capacity times the percent availability of the facility. (The

load factor for electricity generation reduces output further.) Maximum output decreases over time as the ratio of operating cost to the price of output increases. Operating costs are assumed to increase as the facility ages and utilization factors are assumed to depend on the ratio of output product price to operating cost.

## **Sectoral Assumptions**

### **Utility Electricity Assumptions (Excluding Nuclear)**

- No imports or exports are assumed.
- Load factors are equal to the 1995 factors used in the midterm analysis.
- Oil and gas boiler generation is phased out according to midterm assumptions.
- All new, conventional, coal-fired boilers use stack gas scrubbers or the equivalent.
- The new technologies considered are: low-Btu gas (from coal) combined cycle, fuel cells supplied by oil and coal gasifiers, atmospheric fluidized-bed combustion, magnetohydrodynamics (MDH), geothermal (regionally bounded), wind (gas turbine backup), solar thermal and photovoltaic, biomass, and ocean thermal energy conversion (OTEC) (regionally bounded).
- Supply curves for four renewable resource technologies represent the costs of increased use of biomass and geothermal resources and the limited regional availability of solar and OTEC.
- Utility use of lignite is regionally bounded to reflect the difficulties of transportation.

### **Nuclear Assumptions**

- Midterm light-water reactor (LWR) build limits are used through 1995 and are smoothed beyond 2000.
- The fast-breeder reactor (FBR) is assumed available in 2010.
- The output from fusion reactors is assumed nominal for 2020.
- Satisfactory solution to ultimate disposal of nuclear waste problems is assumed. (Fabrication and waste costs are assumed to be \$0.14 per million Btu in 1979 dollars.)
- The once-through LWR fuel cycle becomes more efficient after 1990.

- Centrifuge enrichment is available in 1985.
- Cost of electric power for enrichment is endogenously determined.
- Plutonium for FBR is valued at the cost of recovery from spent fuel.

### Resource Assumptions

- No price regulations are assumed.
- Domestic crude oil price is set equal to the price of imported crude at the refinery. Synthetic liquids are priced at the long-term minimum acceptable price. The price of refinery inputs is the weighted average of the prices of imported oil and synthetic crude oil.
- The market price of high-Btu gas is the weighted average price (including transmission costs) of gas from all sources including imports.
- Rent (defined above) is added to the calculated minimum acceptable price.
- Production from a mine or well is at the maximum permissible rate, if demanded. Maximum production for coal and uranium is constant over the life of the mine and then ceases. Production from oil and gas wells declines exponentially.
- The amount of coal exports is set at midterm levels through 1995 and is assumed to increase slowly thereafter.
- Metallurgical use of western coal is bounded at the 1975 market share.
- Lignite consumption is bounded in all uses.
- Refining of boiler fuel from coal and shale oil costs 50 percent more than crude oil refining and requires 50 percent more fuel.
- A maximum of 50 percent of refinery fuel is natural gas, with the rest derived from the crude input to the refinery.
- Direct consumption of boiler fuel from coal is bounded to assure a market for residual fuel oil from refineries.

### Transportation and Distribution Costs

- Transportation costs, derived from midterm data, are added to the cost of production of resources and synthetic fuels before the market prices are calculated. These costs differ among the producing regions.
- Distribution costs, which differ by fuel and consuming sector, are added to determine the delivered costs. The distribution costs of coal,

oil products, and electricity are calculated to set the 1995 delivered prices equal to those of midterm.

### Industry Assumptions

- Refinery fuel and plant and field use of oil and gas are endogenously determined.
- Electricity for uranium enrichment is endogenously determined.
- Other industrial demands in 1995 are adjusted to the midterm levels.
- After 2000, the growth rate of demand relative to that of GNP decreases to one-half of the 1995-2000 rate, representing improvements in energy efficiency beyond those incorporated in the analysis through 2000. The exception is the relative growth rate of asphalt and road oil, which is reduced to that of automotive vehicle-miles.
- All cogenerated output is used by industry.
- In cogeneration, the price of steam is determined by the weighted average price of steam from all other sources, and the price of electricity is based on the total cost less the value of the steam.
- Cogenerated output is bounded. The steam component is limited to be no more than 50 percent of total indirect heat.
- Industrial use of geothermal heat is bounded.
- The cost of biomass is derived from a biomass resource curve.
- The direct heat use of coal is bounded, restricting it to uses not requiring clean fuel.
- New technologies represented in the industrial sector are: low- or medium-Btu gas from coal, atmospheric fluidized-bed combustion (AFB), geothermal, solar (oil backup), cogeneration using AFB and low- or medium-Btu gas, and electric heat pump to upgrade waste heat.

### Transportation Assumptions

#### Automobile.

- A 1975 new car efficiency of 14.4 mpg is assumed to increase at about 3 percent yearly (meeting the legislated efficiency standards through 1985) to 50.0 mpg by 2020. Because this is the average new-car mileage, the fleet average for any year would be somewhat lower. (In 2020, the fleet average is 37 mpg.)

- Electric vehicles are assumed to be about 2.6 times more efficient than conventional automobiles in 2000.
- Vehicle-miles of travel (VMT) are assumed to increase from 1,051 billion in 1975 to about 2,141 billion by 2020, at a yearly rate of 1.6 percent, based on projections from Jack Faucett Associates, Inc. (See Long-Term section of Bibliography.) The intracity-intercity mileage split of 43/57 percent in 1975 changes to about 35/65 percent by 2000 and is assumed to remain at that ratio through 2020. (Estimates through 1995 are from the Argonne National Laboratory.) An intercity trip in the Argonne analysis corresponds to the National Travel Survey definition of a round trip greater than 100 miles.
- Diesel penetration is considered implicitly via improvements in fuel standards. The input fuel to automobiles is light oil, which includes gasoline, gasohol, and diesel.
- Annual miles traveled per automobile is assumed to increase from about 10,800 to 14,000 miles per year in 2000. The Faucett and Argonne projections use this assumption.
- Fleet cars, used mainly for government and commercial business, are included in this analysis. These fleet autos comprise about 11 percent of the total auto stock and are operated more intensively (22,000 miles per year).

#### **Light Truck.**

- The efficiency of new light trucks is assumed to increase from 10.8 mpg in 1975 to 16.8 mpg in 1985 and 26 mpg in 2020. Light truck travel is estimated to increase from 212 billion vehicle-miles in 1975 to 487 billion vehicle-miles in 2020, based on estimates from Jack Faucett Associates, Inc.
- A light truck is defined as any truck under 10,000 pounds. This category includes pickups, vans, utility vehicles, and jeeps.
- Annual miles traveled per light truck are assumed constant at 11,000 miles per vehicle over the projection period.
- The light truck category includes trucks used for personal transportation and commercial and government uses.

#### **Bus.**

- Bus energy efficiency is assumed to remain at 1975 levels over the projection period. No shift to different sized vehicles is assumed.
- The vehicle-miles per gallon figure is a weighted average of school, transit, and intercity buses, based on the percentage of total vehicle-miles traveled.
- Bus travel is assumed to increase from 5 billion vehicle-miles in 1975 to 10 billion vehicle-miles in 2020.
- No dramatic public interventions in transit policy are assumed.

#### **Aircraft.**

- New aircraft efficiency is assumed to increase at a rate of 1.5 percent per year, based on an average of projected efficiencies of new equipment.
- Total revenue passenger-miles are assumed to increase from 173 million in 1975 to 672 million in 2020. The air category includes both domestic and international (U.S. carrier activity only) passenger-miles and fuel use.
- General aviation, which is usually measured in vehicle-miles rather than passenger-miles, is not explicitly included because its share is relatively minor. Fuel consumption in later years may be slightly higher than the levels assumed to allow for the projected growth in this category (0.5 quads by 2000).
- Military use of aircraft fuel is not considered.

#### **Heavy Truck.**

- The efficiency of heavy trucks is assumed to increase about 0.9 percent per year, measured in ton-miles per gallon.
- The ton-mile estimates, based on intercity freight movement only, are projected to increase from 454 million ton-miles in 1975 to 1,278 million ton-miles by 2020.

#### **Rail.**

- Rail ton-mile figures are based on projections from the Argonne National Laboratory through 2000. The data cover all commodity movements, including energy shipments. Ton-miles of rail transportation are assumed to increase at a yearly rate of 1.7 percent from 2000 to 2020.

- Rail efficiency is assumed to increase at a rate of 10 percent per year through 2000 and remain constant from 2000 to 2020. Increased rail movements of coal are considered in this analysis.

#### **Marine.**

- Marine transport covers domestic ton-miles only—including inland waterways, Great Lakes, and domestic ocean. A 1.3 percent per year growth rate is assumed for marine transportation post-2000.

#### **Residential Assumptions**

- The basic structure and data for the residential sector are from the HIRST residential demand model, developed by Oak Ridge National Laboratory (ORNL). The major source of information is a Residential Energy Use Simulation 1970-95, version 5, without the exogeneous conservation shifts, (February 1980). This report supplies fuel use by type and end-use function. Projections of specific types of equipment (e.g., space heaters, refrigerators) including fuel use, equipment price, equipment market shares, and efficiency changes are also available. All estimates beyond 1995 are extrapolations of HIRST trends.
- 1975 input data on fuel use by sector is from the State Energy Data System (SEDS) data base.
- The HIRST Model covers only conventional end-use technologies. LEAP also includes:
  1. Electric heat pump—available in 1975, with an efficiency of about 1.7. Heat pumps are assumed to supply both space heating and cooling.
  2. Gas heat pump—available 1990, with an efficiency of 1.5.
  3. Solar space heating—the system assumed is a liquid space heating system with 500 square feet of flat plate collectors and includes a minimum amount of storage and an electric resistance backup. The cooling system is represented as a separate unit. (See solar space cooling.)
  4. Solar space cooling—typically solar cooling systems are combined with solar heating systems, sharing some of the components.

To allocate the costs of separate systems, the fixed cost component of a similar solar space heating system is deducted from the total cost of a combined solar heating and cooling system. Cooling loads are assumed to be a U.S. average, and system capacity is set at 2 tons.

5. Photovoltaics—assumed available for residential electricity generation after 1990. Capital costs are assumed to decrease at a rate of 5 percent per year. An average availability of 0.2 is assumed for each system.
  6. Solar water heating—system size is based on an average household demand of 80 gallons per day of 140° F water. Half of the systems now being installed are assumed to be on new homes; half are retrofits. Capital costs are expected to decrease over time.
- Three housing types are represented—single, multifamily, and mobile homes. New homes are assumed to be more energy efficient than existing homes, although the thermal integrity of all homes is expected to improve over the projection period.

#### **Commercial Assumptions**

- The commercial sector disaggregates the demand for energy into five end uses: space and water heating, cooling, lighting, other electric services, and other gas services. Data inputs are from the Jackson Model (also from ORNL) through 1995. Demands by specific commercial activities (such as, retail-wholesale and hospitals) are not considered individually.
- Photovoltaics are not included in the commercial analysis.
- Space and water heating demands are considered together because the energy used for commercial water heating is a small fraction of total energy demanded for the sector.

#### **Sensitivity Cases Assumptions**

- Thermal Integrity—This scenario assumes the thermal integrity of homes to improve five times as fast as the rate assumed in the midprice case. (See glossary for definition of thermal integrity.)

- **Electric Car**—This scenario assumes that the initial capital cost of purchasing an electric car is approximately equal to that assumed for a conventional automobile in the midprice case.
- **High capital costs for new technologies**—The capital costs for new technologies (synthetic liquid and gas, new coal utility technologies, fuel cells, solar, OTEC, wind, and residential photovoltaic) assumed in the midprice case are doubled. The capital costs of new technologies in the midprice case are raised by a factor of 1.86 to reflect pioneer plant costs, which are assumed to decline rapidly to the best estimates of mature plant costs. Thus, the resulting factor used for the high capital cost scenario is 3.72, declining to 2 to represent the transition from pioneer to full-scale commercial plants. (Edward Merrow, of the RAND Corp., determined that the final costs of projects are approximately 3 times the initial estimates, with a standard deviation of one. See Long-Term section of Bibliography.)
- **Nuclear Phaseout**—This scenario assumes that light-water reactors will be phased out after a 30-year operating life, that only nuclear units currently under construction and at least 10 percent complete will be allowed to complete construction and enter service, and that no new nuclear plants will be added after 1995. Build limits used are consistent with those used in the midterm analysis. The fast breeder reactor is not allowed to be deployed.
- **High Capital Cost and Nuclear Phaseout**—This scenario combines the assumptions of the previous two scenarios.
- **Low Nuclear Supply**—This scenario is an extension of the low nuclear supply case from the midterm analysis. Limits (upper bounds) on electrical output produced by the light-water reactor in the midterm are:

Year	Quadrillion Btu per Year
1985	1.68
1990	2.36
1995	2.66

Light-Water reactors are assumed to operate at 65 percent of capacity through 2000 and at 75 percent of capacity from 2000 to 2020.

- **High Nuclear Supply**—This scenario is an

extension of the high nuclear supply case from the midterm analysis. Limits (upper bounds) used in the midterm for electrical output produced by the light-water reactor are:

Year	Quadrillion Btu per Year
1985	2.11
1990	2.71
1995	3.10

Reactors are assumed to operate at 65 percent of capacity throughout the projection period.

## Detailed Assumptions

### Financial Assumptions

Activity	Return on equity (percent)	Return on debt (percent)	Percent equity
Resource production	0.10	0.04	0.65
Electric power generation	0.10	0.04	0.45
Synthetic liquids production	0.10	0.04	0.60
Synthetic gas production	0.10	0.04	0.45
Industrial end-use	0.10	0.04	0.60
Commercial end-use	0.10	0.04	0.20

### Fuel Price Elasticity Assumptions

These assumptions are used for the low- and high-world oil price scenarios.

Residential sector	
All fuels	-0.35
Commercial sector	
All fuels	-0.89
Industrial sector	
All fuels	-0.54
Transportation sector	
Jet fuel	-0.975
All other fuels	-0.376

Derived from midterm results for 1995.

### Service Demand Elasticity Assumptions

These assumptions are used for the low- and high-world oil price scenarios.



Residential sector

All services -0.96

Commercial sector

All services -1.18

Industrial sector

Direct heat -0.43

Indirect heat -0.43

Electric services 0.13

Feedstock -0.11

Metallurgical coal -0.11

Lubes, waxes -0.11

Transportation sector

Automobile (oil) -0.84

Automobile (electric) -2.32

Light truck -1.727

Aircraft -1.486

Bus -0.58

Coal Export Assumptions

Year	Quadrillion Btu per Year
1980	2.00
1985	2.16
1990	2.72
1995	3.59
2000	3.65
2005	3.70
2010	3.75
2015	3.80
2020	3.85

Electric Generating Plant Specifications

Plant Type	Capital Costs <sup>a</sup> (1975 dollars/ KW/year)	Capital O&M Costs (1975 mills/ kWh)	Thermal Efficiency	Year Commercially Available	Capacity Factor <sup>b</sup>	Facility Life	Planning Lead Time <sup>c</sup>
Coal Boiler <sup>d</sup>	671	4.9	0.35	1930	0.59 (B)	30	12
Oil Boiler	433	1.0	0.35	1930	0.61 (B)	30	12
Oil Turbine	133	2.3	0.25	1950	0.45 (I)	30	4
Gas Boiler	433	0.9	0.35	1945	0.61 (B)	30	12
Gas Turbine	123	2.3	0.25	1950	0.08 (P)	30	4
Fuel Cell, Coal-to-Gas <sup>e</sup>	800	2.6	0.44	2000	0.73 (B)	30	10
Fuel Cell, Oil <sup>e</sup>	350	2.6	0.38	1990	0.34 (I)	30	4
Combined Cycle <sup>e,f</sup>	630	3.4	0.37	1995	0.70 (B)	30	10
AFB <sup>g</sup>	485	3.3	0.35	1995	0.70 (B)	30	10
Geothermal <sup>h</sup>	577	1.3	1.0	1975	0.70 (B)	30	12
Biomass	1,338	4.5	0.24	1975	0.70 (B)	30	8
MHD <sup>i</sup>	565	1.9	0.45	2005	0.66 (B)	30	18
Solar <sup>h</sup>	735	2.3	1.0	1990	0.26 (B)	30	12
OTEC <sup>j</sup>	1,982	5.7	1.0	1995	0.78 (B)	30	10
Wind/Gas Turbine <sup>l</sup>	956	4.9	0.41	1985	0.35 (B)	20	10
LWR <sup>m</sup>	910	1.8	0.31	1970	0.70 (B)	30	13
FBR <sup>k</sup>	1,425	3.3	0.365	2010	0.62 (B)	30	15

<sup>a</sup>Excludes interest costs during construction.

<sup>b</sup>Value is for the load factor category with the highest capacity factor in which the technology operates, as indicated in parenthesis: (B) = base, (I) = intermediate, (P) = peak.

<sup>c</sup>The time lapse from the initial decision to build to full-scale operation of the plant.

<sup>d</sup>Bituminous medium sulfur coal, with scrubber. Costs are increased over time to reflect the effect of stricter air quality standards.

<sup>e</sup>Capital costs are raised by a factor of 1.86 to reflect pioneer plant costs and decline rapidly to the indicated mature costs.

<sup>f</sup>Medium-Btu gas from coal, Texaco gasification.

<sup>g</sup>Dry steam.

<sup>h</sup>Photovoltaics as representative technology.

<sup>i</sup>Wind provides 40 percent of the output, and this portion of total capital costs has been inflated by a factor of 1.73 to reflect pioneer plant costs.

<sup>j</sup>The reactor core has a life of 15 years.

<sup>k</sup>Capital costs for breeder reactors decline ultimately to 90 percent of initial costs.

## Synthetic Gas and Liquids Technology Specifications

Process	Capital Costs*	O&M Costs (1975 dol- lars/ million Btu)	Conversion Efficiency	Year	Capacity Factor	Facility Life	Planning Lead Time
	(1975 dol- lars/ million Btu/year)			Commercially Available			
<b>Syncrude</b>							
Eastern.....	13.79	0.84	0.50	1990	0.9	30	8
Western.....	13.79	0.84	0.50	1990	0.9	30	8
<b>Methanol</b>							
Eastern.....	16.67	1.68	0.60	1995	0.9	20	8
Western.....	16.67	1.68	0.60	1995	0.9	20	8
<b>Boiler Fuel</b>							
Eastern.....	13.79	0.84	0.70	1995	0.9	20	8
Western.....	13.79	0.84	0.70	1995	0.9	20	8
Alcohol from Biomass.....	26.90	2.00	0.52	1980	0.9	20	8
<b>High-Btu Gas</b>							
<b>Commercial Technology</b>							
Eastern.....	14.27	1.09	0.47	1990	0.9	30	8
Western.....	13.29	0.93	0.67	1985	0.9	30	8
<b>Advanced Technology</b>							
Eastern.....	12.02	1.23	0.72	1995	0.9	20	8
Western.....	10.90	0.93	0.75	1995	0.9	20	8

\*Excludes interest during construction. Except for alcohol from biomass, capital costs are raised by a factor of 1.86 to reflect pioneer plant costs, and decline rapidly to the indicated mature costs.

## End-Use Technology Specifications—Residential

Application and Fuel	Capital Costs*	O&M Costs (1975 dollars/ million Btu)	Efficiency <sup>b</sup> or C.O.P.	Year	Capacity Factor	Facility Life
	(1975 dol- lars/ million Btu/ year)			Commercially Available		
<b>Space Heat</b>						
Oil.....	31.37	0.74	0.60	1930	0.9	15
Gas.....	23.13	0.62	0.65	1930	0.9	15
Electric Resistance.....	13.59	0.59	0.98	1930	0.9	15
Electric Heat Pump.....	45.00	1.41	1.70	1975	0.9	15
Gas Heat Pump.....	73.35	1.75	1.50	1990	0.9	15
Coal, LPG.....	11.45	0.20	0.40	1930	0.9	10
Solar.....	92.60	1.80	2.50	1980	0.9	20
Geothermal.....	18.26	2.22	1.00	1980	0.9	20
<b>Space Cool</b>						
Electric.....	24.17	0.39	2.18	1950	0.9	15
Solar.....	494.00	2.00	2.00	1985	0.9	20
<b>Water Heat</b>						
Oil.....	16.92	0	0.60	1930	0.9	12
Gas.....	15.38	0	0.70	1930	0.9	12
Electric.....	9.23	0	0.98	1930	0.9	12
Solar.....	80.00	1.60	4.00	1980	0.9	17
Lighting.....	7.96	0	1.00	1930	0.9	10
Refrigerator.....	87.99	0	0.91	1930	0.9	13
Freezer.....	67.81	0	0.94	1940	0.9	18
<b>Cooking</b>						
Electric.....	65.02	0	1.00	1930	0.9	13
Gas.....	78.70	0	.65	1930	0.9	13
Other Gas <sup>e</sup> .....	11.34	0	0.65	1930	0.9	13
Other Electric <sup>d</sup> .....	14.57	0	1.00	1950	0.9	10
Photovoltaic Electricity.....	50.00	0.35	4.00	1990	0.2	20

\*Capital costs of most technologies increase to reflect the cost of technical improvements. The capital cost of solar technologies decrease because of manufacturing improvements and economies of scale.

<sup>b</sup>Efficiencies improve over time because of design improvements.

<sup>c</sup>Includes clothes driers, air conditioners, and refrigerators.

<sup>d</sup>Includes televisions, small appliances, clothes driers, and dishwashers.

C.O.P. = coefficient of performance.

## End-Use Technology Specifications—Commercial

Application and Fuel	Capital Costs <sup>a</sup> (1975 dollars/ million Btu/ year)	O&M Costs (1975 dollars/ million Btu)	Efficiency or C.O.P. <sup>b</sup>	Year Commercially Available	Capacity Factor	Facility Life
<b>Space and Water Heat</b>						
Light Oil.....	30.35	0.71	0.60	1930	0.9	20
Heavy Oil.....	30.35	0.71	0.60	1930	0.9	20
Gas.....	22.90	0.57	0.65	1930	0.9	20
Electric.....	12.98	0.30	1.05	1930	0.9	20
Solar.....	85.67	2.00	2.50	1980	0.9	20
Geothermal.....	18.10	2.24	1.00	1980	0.9	20
<b>Space Cool</b>						
Electric.....	32.00	0.34	1.00	1950	0.9	20
Solar.....	85.67	2.00	2.50	1985	0.9	20
<b>Lighting</b>						
Lighting.....	3.00	0	1.00	1930	0.9	10
Other Electric <sup>c</sup> .....	19.80	0	1.00	1930	0.9	20
Other Gas <sup>d</sup> .....	11.34	0	0.65	1930	0.9	20

<sup>a</sup>Except for solar, capital costs increase to reflect technology improvements.

<sup>b</sup>Efficiencies are assumed to improve over time.

<sup>c</sup>Elevators, computers, and machine drive.

<sup>d</sup>Mostly restaurant cooking.

C.O.P. = coefficient of performance.

## End-Use Technology Specifications—Industrial

Application and Fuel	Capital Costs (1975 dol- lars/ million Btu/ year)	O&M Costs (1975 dollars/ million Btu)	Efficiency	Year Commercially Available	Capacity Factor	Facility Life
<b>Direct Heat</b>						
Oil <sup>a</sup> .....	2.31	0.12	0.29	1930	0.9	25
Gas <sup>a</sup> .....	1.60	0.08	0.30	1930	0.9	25
Low-Btu Gas <sup>a</sup> .....	8.69	0.58	0.23	1985	0.9	20
Coal <sup>a</sup> .....	3.85	0.31	0.30	1930	0.9	25
<b>Indirect Heat</b>						
Oil Boiler.....	3.20	0.23	0.75	1930	0.9	25
Gas Boiler.....	2.86	0.18	0.75	1930	0.9	25
Low-Btu Gas Boiler <sup>a</sup> .....	9.75	0.94	0.61	1985	0.9	20
Coal Boiler.....	6.85	0.38	0.70	1930	0.9	25
AFB (Coal) Boiler.....	8.56	0.75	0.82	1985	0.9	25
Electric Heat Pump <sup>a</sup> .....	8.43	0.69	2.00	1960	0.9	15
Biomass Boiler.....	5.38	0.85	0.60	1975	0.9	20
Geothermal.....	2.79	1.19	1.00	1980	0.9	25
Solar Thermal (Oil Backup) <sup>b</sup> .....	52.00	1.57	3.00	1980	0.9	20
<b>Coal Autogeneration</b>						
Coal Autogeneration	44.70	2.20	0.32	1930	0.9	25
<b>Gas Autogeneration</b>						
Gas Autogeneration	19.50	0.91	0.33	1930	0.9	25
<b>Oil Cogeneration<sup>c</sup></b>						
Oil Cogeneration <sup>c</sup>	29.20	1.11	0.23	1980	0.9	25
<b>Low-Btu Gas Cogeneration<sup>c</sup></b>						
Low-Btu Gas Cogeneration <sup>c</sup>	66.00	5.56	0.13	1980	0.9	25
<b>AFB Cogeneration<sup>c</sup></b>						
AFB Cogeneration <sup>c</sup>	102.00	8.35	0.08	1980	0.9	25

<sup>a</sup>Efficiencies improve gradually over the projection period.

<sup>b</sup>Capital costs decrease over the projection period.

<sup>c</sup>Efficiencies represent electricity/fuel ratio.

Process steam/electricity ratios are: Oil—2.5

LBG—4.0

AFB—9.0

## End-Use Technology Specifications— Transportation

Application and Fuel	Capital Costs (1975 dollars/1,000 miles/year) <sup>a</sup>	O&M Costs (1975 dollars/1,000 miles)	Commercially Available	Capacity Factor	Facility Life
Aircraft <sup>b</sup> .....	144.8	12.8	1950	0.9	15
Automobile—					
Oil <sup>c</sup> .....	470.0	100.7	1930	0.9	10
Automobile—					
Electric <sup>c</sup> .....	690.0	191.0	1990	0.9	10
Light Truck <sup>c</sup> .....	470.0	100.7	1930	0.9	10
Heavy Truck <sup>d</sup> .....	1,082.0	2.0	1930	0.9	15
Bus <sup>c</sup> .....	132.0	80.0	1930	0.9	15
Rail <sup>d</sup> .....	81.0	20.7	1930	0.9	20
Marine <sup>d</sup> .....	23.4	5.0	1930	0.9	20

<sup>a</sup>Capital costs are assumed to increase for autos, light trucks, and aircraft.

<sup>b</sup>Passenger-miles.

<sup>c</sup>Vehicle-miles.

<sup>d</sup>Ton-miles.

Note: Efficiency assumptions are given in the sectoral assumption section.

## Upper Bounds on Electricity-Generating Output

(Quadrillion Btu per Year)

Year	Technology						
	Hydro	LWR	Wind	Biomass	Solar	OTEC	Geothermal
1975.....	1.005	0.580	0	0.001	0.001	0	0.010
1980.....	1.032	1.250	0	0.003	0.002	0	0.014
1985.....	1.065	1.910	0.002	0.012	0.002	0.001	0.063
1990.....	1.065	2.480	0.006	0.025	0.011	0.007	0.147
1995.....	1.065	2.930	0.048	0.048	0.077	0.038	0.295
2000.....	1.065	3.490	0.077	0.068	0.124	0.144	0.530
2005.....	1.065	4.900	0.125	0.100	0.200	0.480	0.670
2010.....	1.065	6.800	0.200	0.120	0.320	0.720	0.800
2015.....	1.065	*	0.320	0.140	0.520	1.440	0.926
2020.....	1.065	*	0.520	0.170	0.830	2.000	1.050

\*Not bounded.

Note: Bounds may not be binding.

## Upper Bounds on Synthetic Fuels Production

(Quadrillion Btu per Year)

Year	Products from				
	Heavy Crude (Coal & Shale)	Methanol from Coal	Alcohol from Biomass	Syncrude from Coal	Syngas from Coal
1975.....	0.0	0.0	0.0	0.0	0.0
1980.....	0.0	0.0	0.05	0.0	0.0
1985.....	0.06	0.0	0.12	0.0	0.04
1990.....	0.42	0.03	0.25	0.12	0.16
1995.....	0.90	0.13	0.45	0.40	0.41
2000.....	1.90	0.30	0.80	1.00	1.00
2005.....	3.00	0.70	1.20	2.00	2.00
2010.....	4.50	1.50	1.80	3.50	3.50
2015.....	6.50	3.00	2.50	5.50	5.50
2020.....	7.50	5.00	3.00	8.00	8.00

Note: Bounds may not be binding.

## Upper Bounds on End-Use Demands

(Quadrillion Btu per Year)

Year	Geothermal			Biomass	
	Residential	Commercial <sup>a</sup>	Industrial	Industrial Heat	Paper Industry Wastes
1975.....	0	0	0.001	1.000	0.877
1980.....	0	0	0.002	1.270	1.092
1985.....	0.001	0	0.004	1.550	1.477
1990.....	0.005	0.003	0.041	1.850	1.741
1995.....	0.020	0.010	0.085	2.150	1.879
2000.....	0.060	0.025	0.139	2.390	2.014
2005.....	0.150	0.040	0.197	2.610	2.230
2010.....	0.300	0.050	0.265	2.720	2.400
2015.....	0.450	0.063	0.344	2.920	2.550
2020.....	0.630	0.075	0.435	3.110	2.690

<sup>a</sup>Percent of the space and water heat market. Upper bound is determined by multiplying these percentages by the total space and water heat demand in the indicated year.

Note: Bounds may not be binding.

**Upper Bounds on Lignite Coal to Electricity**  
**(Quadrillion Btu per Year)**

---

Year	Electricity Generation
1975 .....	0.220
1980 .....	0.480
1985 .....	1.050
1990 .....	1.130
1995 .....	1.310
2000 .....	1.530
2005 .....	1.770
2010 .....	2.000
2015 .....	2.220
2020 .....	2.420

---

Note: Bounds may not be binding.

# Index

- Acid rain, 138**  
SEE ALSO Coal: environmental aspects.
- Air conditioners, 181; TABLE, 176**
- Air emissions:**  
fossil fuels, 138  
SEE ALSO entries under specific types of air emissions.
- Air quality, 138**
- Aircraft:**  
energy consumption, 94, 172, 179  
fuel efficiency, 95  
passenger miles traveled, 95, 97, 179; TABLE, 180
- Alaskan natural gas, 122, 128**  
prices, TABLE, 129, 131  
production, 131; TABLE, 150, 207, 208
- Alaskan Natural Gas Pipeline, 5, 124, 207**  
capacity, 67, 131
- Alaskan petroleum, 120-122, 200**  
production, 51, 74, 131, 151, 204; FIGURE, 120, 211; TABLE, 54-55, 122, 151, 204, 205  
SEE ALSO Trans-Alaskan Pipeline.
- Alcohol fuels, 193, 197; TABLE, 195, 216**  
production, 165; FIGURE, 211; TABLE, 205  
SEE ALSO Ethanol; Gasohol; Methanol.
- Algeria:**  
natural gas exports, 68  
natural gas liquids production, TABLE, 19  
petroleum production, TABLE, 19
- Alternative fuel cost ceiling**  
SEE Natural gas: substitute fuel cap.
- American Gas Association forecast, 148; TABLE, 150**
- Appliances:**  
energy consumption, 99; TABLE, 176  
energy efficiency standards, 99, 105
- Arab oil embargo, 102, 106**
- Asphalt:**  
consumption, 104; TABLE, 175  
demand, TABLE, 172, 176  
production, 116
- Atmospheric fluidized-bed (AFB), 182**  
electric power generation, 192; TABLE, 189, 195, 216
- Australia/New Zealand:**  
economics, TABLE, 9, 23  
energy consumption, TABLE, 26, 27, 28, 29, 30  
energy production, TABLE, 30  
fuel shares, TABLE, 26, 27, 28  
nuclear power, TABLE, 31  
petroleum consumption, TABLE, 22, 29  
petroleum import payments, TABLE, 23  
petroleum production, TABLE, 22
- Autogeneration**  
SEE Industrial sector: electric power generation.
- Automobiles:**  
diesel-fueled, 94, 97, 99  
energy efficiency standards, 81-82, 94, 97  
fuel consumption, 36, 94, 116, 179; TABLE, 176, 180  
fuel efficiency, 83, 94-95, 97-99, 145, 167, 179  
sales, 139  
vehicle miles traveled, 95, 179; TABLE, 180  
SEE ALSO Transportation sector.
- Babcock & Wilcox, McDermitt Corp. forecast, TABLE, 149**
- Biomass, 165, 177, 192-193, 197, 214-215; TABLE, 175**
- Bituminous coal, TABLE, 200**  
prices, TABLE, 84, 137, 143, 144, 153  
SEE ALSO Coal.
- Boilers, 88, 91**  
fuel switching, 138  
fuel use, 91, 93, 114, 116, 144
- Buildings:**  
energy conservation, 99, 102-103  
energy consumption, 102-103  
energy performance standards, 81-82, 99  
SEE ALSO Residential buildings.
- Bunker oils**  
SEE Residual fuels.
- Bureau of the Census population forecast, 87-88**
- Buses:**  
energy consumption, 94; TABLE, 176, 180  
fuel efficiency, 95
- Canada:**  
economics, TABLE, 9, 23  
energy consumption, 9; TABLE, 26, 27, 28, 29, 30  
energy production, TABLE, 30  
fuel shares, TABLE, 26, 27, 28  
natural gas exports, 67, 68, 128; TABLE, 126, 129, 131  
natural gas production, 124  
nuclear power, TABLE, 31  
petroleum consumption, 15; FIGURE, 17; TABLE, 16, 22, 29  
petroleum import payments, TABLE, 23  
petroleum production, TABLE, 20, 22
- Carbon dioxide emissions, 138**
- Cars**  
SEE Automobiles.
- Centrally planned economies**  
SEE Communist countries.
- Coal:**  
consumption, coke plants, 138; TABLE, 74-75, 77-78, 137  
consumption, commercial sector, TABLE, 145, 146  
consumption, domestic, 30, 37, 71, 72-73; FIGURE, 157, 158, 168, 171, 174; TABLE, 36, 74-75, 76, 77-78, 137, 152, 162  
consumption, electric utilities, 73, 75, 79, 106, 137; TABLE, 36, 46-47, 74-75, 77-78, 137, 200  
consumption, industrial sector, 74, 91, 116, 137-138, 144, 152-153, 177, 178; FIGURE, 92; TABLE, 93, 137, 175, 200, 202  
consumption, international, 24, 31  
consumption rates, 73; TABLE, 26, 27, 28  
consumption, residential sector, 194-195; TABLE, 175, 200, 202  
consumption, transportation sector, 152-153  
demand, domestic, 162-163, 177; TABLE, 74-75, 83, 172  
demand, international, 24  
disposition, 200, 202; TABLE, 46-47, 74-75, 165, 169, 200, 202  
electric power generation, 106, 110, 154, 162; FIGURE, 107, 187; TABLE, 108, 110, 113, 147, 149, 189, 190  
environmental aspects, 72, 91, 134, 135-136, 138, 148

- Coal (Con't.)
- exports, 15, 138, 148, 200, 202; TABLE, 74-75, 77-78, 137, 165, 169, 200
  - imports, TABLE, 46-47, 74-75, 77-78, 83, 143, 144, 152
  - new technology, 186, 188; TABLE, 189
  - prices, 86, 91, 133-134, 135-136, 166, 198, 200; FIGURE, 199; TABLE, 40-41, 84, 137, 143, 153, 166, 170
  - prices, retail, 71
  - production, domestic, 37, 44, 68, 71-72, 74, 79, 81, 134, 163, 200, 202; FIGURE, 135, 201; TABLE, 46-47, 74-75, 76, 77-78, 83, 134, 137, 144, 162
  - reserves, 198, 202
  - resources, 134, 136
  - stock withdrawals, TABLE, 74-75
  - stocks, 71; TABLE, 74-75
  - supply, domestic, 162, 200; FIGURE, 157, 168; TABLE, 36, 74-75, 76, 83, 143, 152, 160, 165, 169, 195, 200, 202
  - transportation, 134, 136, 154
  - SEE ALSO Bituminous coal; Coal gasification; Coal liquefaction; Lignite; Metallurgical coal; Subbituminous coal; Western coal.
- Coal-based synthetic fuels
- SEE Coal gas; Coal liquids; Synthetic fuels.
- Coal gas, 196
- consumption, 162
  - high-Btu gas, 176, 193; TABLE, 207, 208, 216
  - low-Btu gas, 176, 182
  - medium-Btu gas, 176-177, 182
  - SEE ALSO Synthetic natural gas.
- Coal gasification, 193, 194, 195-197, 200; TABLE, 195, 200, 202, 216
- bi-gas process, 196
  - CO<sub>2</sub> acceptor process, 196
  - hygas process, 196
  - in-situ process, 196
  - Lurgi process, 196
  - molten salt process, 196
  - production, FIGURE, 211
- Coal industry:
- capital expenditures, 136
  - growth rate, 166
  - regulation, 71
  - strikes, 71
- Coal liquefaction, 177, 193, 194, 195-197, 200; TABLE, 195, 200, 205, 216
- environmental aspects, 197
  - Fischer-Tropsch synthetic process, 196, 197
- Coal liquefaction (Con't.)
- hydroliquefaction, 196, 205
  - production, FIGURE, 211; TABLE, 195, 200
  - pyrolysis, 196
  - Solvent Refined Coal Process I, 197
  - Solvent Refined Coal Process II, 197
- Coal liquids:
- production, 119; TABLE, 122, 151, 195, 200, 204, 205, 216
  - SEE ALSO Coal liquefaction; Synthetic fuels.
- Coal mining, 136; TABLE, 134
- legislation, 135-136
  - SEE ALSO Coal industry.
- Coal projection series:
- long-term, 162-163, 177, 200, 202
  - long-term, Series High, TABLE, 202, 216
  - long-term, Series Low, TABLE, 202, 216
  - long-term, Series Middle, TABLE, 195, 200, 202, 216
  - midterm, 91, 133-135, 136, 138, 145, 148, 200; FIGURE, 135; TABLE, 83, 84, 149
  - midterm, Series High, 135; TABLE, 83, 84, 93, 134, 137
  - midterm, Series Low, 135; TABLE, 83, 84, 93, 134, 137
  - midterm, Series Middle, 86, 135; TABLE, 83, 84, 93, 134, 137
  - short-term, 136
- Cogeneration
- SEE Industrial sector: electric power generation.
- Coke:
- consumption, 73
  - exports, TABLE, 165
  - imports, TABLE, 46-47
- Commercial sector, TABLE, 104
- coal consumption, TABLE, 145, 146
  - distillate consumption, FIGURE, 101
  - distillate prices, TABLE, 104
  - electric power consumption, 26, 99, 104; FIGURE, 101; TABLE, 103, 104, 108, 145, 146, 175, 190
  - electric power prices, TABLE, 103, 104, 109
  - energy conservation, 99; TABLE, 102
  - energy consumption, 26, 99-102, 103, 105, 167, 182; FIGURE, 90, 171, 174; TABLE, 102, 103, 104, 145, 146, 160, 216
  - energy consumption rates, TABLE, 104
- Commercial sector (Con't.)
- energy demand, 26, 167, 172, 181; FIGURE, 159; TABLE, 172
  - energy efficiency, 181
  - energy prices, 132; TABLE, 103, 145, 146, 166, 170, 190
  - fuel consumption, 182; TABLE, 175
  - fuel prices, 182; TABLE, 145, 146
  - fuel use, 81, 172, 181-182, 184; FIGURE, 101; TABLE, 176
  - geothermal energy consumption, 182, 183
  - heavy oil consumption, TABLE, 172, 175
  - heavy oil prices, TABLE, 166, 170
  - light oil consumption, TABLE, 172, 175
  - light oil prices, TABLE, 166, 170
  - liquid gas consumption, FIGURE, 101; TABLE, 104
  - liquid gas prices, TABLE, 104
  - natural gas consumption, 99, 105, 130, 132, 154; FIGURE, 101; TABLE, 103, 104, 145, 146, 175
  - natural gas prices, TABLE, 103, 104, 166, 170
  - petroleum consumption, 99, 146
  - petroleum products consumption, 104; TABLE, 145, 146
  - residual fuel consumption, FIGURE, 101; TABLE, 104
  - residual fuel prices, TABLE, 104
  - solar energy consumption, 182
- Commercial sector energy projection series:
- assumptions, 181
  - comparisons, TABLE, 166, 170, 172
  - long-term, 181; TABLE, 166, 170, 172, 176
  - long-term, Series High, TABLE, 166, 176
  - long-term, Series Low, TABLE, 166, 176
  - long-term, Series Middle, TABLE, 166, 170, 172, 176, 190
  - midterm, 81, 102, 146; TABLE, 172
  - midterm, Series High, TABLE, 103
  - midterm, Series Low, TABLE, 103
  - midterm, Series Middle, FIGURE, 101; TABLE, 102, 103, 104, 172
  - variables, 181
- Committee on Nuclear and Alternative Energy Systems
- forecast, 142, 143, 146, 148, 160-161, 177; TABLE, 144, 149, 160

- Communist countries:  
 net energy trade, 10, 15, 16, 18;  
 TABLE, 18, 22, 30, 33, 34  
 petroleum consumption, 99  
 petroleum production, 16, 18
- CONAES  
 SEE Committee on Nuclear and  
 Alternative Energy Systems.
- Crude oil  
 SEE Petroleum.
- Crude oil entitlements program  
 SEE Petroleum: entitlements.
- Curtailments  
 SEE Natural gas: curtailments.
- Data Resources, Inc. (DRI):  
 economic forecasts, 37, 87  
 energy forecasts, 78, 79, 142, 143,  
 145, 148, 150, 160; TABLE,  
 77-78, 144, 146, 147, 149, 150,  
 151, 160
- Department of Energy utility survey,  
 TABLE, 149
- Developing countries:  
 economic growth, 8  
 energy consumption, 25, 27-28  
 petroleum consumption, 15, 18,  
 21; FIGURE, 17; TABLE, 16,  
 22  
 petroleum production, 21;  
 TABLE, 22
- Diesel fuel  
 SEE Distillate.
- Direct heat processes  
 SEE Industrial sector: direct  
 heat processes.
- Disposable personal income, 38-40, 43,  
 139; TABLE, 38-39
- Distillate, 178  
 consumption, 36, 57-58, 114, 175,  
 179; TABLE, 54-55, 64-65, 76,  
 77-78, 93, 94, 95, 103, 104, 175  
 consumption rates, TABLE, 94,  
 97, 104  
 demand, 58, 75, 114, 172;  
 FIGURE, 62; TABLE, 64, 115,  
 172  
 disposition, TABLE, 54-55, 64-65  
 exports, TABLE, 64-65  
 imports, TABLE, 64-65  
 prices, 75, 114-116, 144-145;  
 TABLE, 38-39, 84, 93, 94, 95,  
 97, 103, 104, 166, 170  
 prices, retail, 43, 86-87; TABLE,  
 115  
 primary stocks, TABLE, 64-65  
 production, TABLE, 64-65  
 refinery output, TABLE, 64-65  
 supply, TABLE, 36, 64-65
- Distillate projection series:  
 midterm, 86-87, 97, 114-116
- Distillate projection series (Con't.)  
 midterm, Series High, 114-116;  
 TABLE, 93, 95, 103  
 midterm, Series Low, 116;  
 TABLE, 93, 95, 103  
 midterm, Series Middle, 116;  
 TABLE, 93, 94, 95, 97, 103,  
 104  
 short-term, TABLE, 64
- Domestic energy supplies  
 SEE Energy supplies: domestic.
- DPI  
 SEE Disposable personal income.
- DRI  
 SEE Data Resources, Inc. (DRI).
- Economic projections, 139, 140, 141  
 economic growth, 7, 8, 14, 24, 33,  
 37, 43, 52, 139, 142, 155;  
 FIGURE, 88; TABLE, 9, 33-39  
 inflation, 139
- Economic Regulatory Administration,  
 147
- Ecuador:  
 natural gas liquids production,  
 TABLE, 19  
 petroleum production, TABLE, 19
- Electric power:  
 conservation, 105  
 consumption, commercial sector,  
 26, 99, 104; FIGURE, 101;  
 TABLE, 103, 104, 108, 145,  
 146, 175, 190  
 consumption, domestic, FIGURE,  
 157, 158, 168, 171, 174;  
 TABLE, 83, 152, 162  
 consumption, industrial sector, 91,  
 105, 177, 178; FIGURE, 92;  
 TABLE, 93, 94, 108, 175, 190  
 consumption rates, 162; TABLE,  
 94, 104  
 consumption, residential sector,  
 26, 146-147, 181; FIGURE, 98,  
 100; TABLE, 103, 104, 108,  
 175, 190  
 consumption, transportation  
 sector, 99, 179; TABLE, 175,  
 190  
 conversion losses, TABLE, 44,  
 46-47, 52-53, 77-78, 83, 165,  
 169  
 demand, 49, 79, 106, 109, 167,  
 186, 189; TABLE, 50, 83, 108,  
 172, 176  
 disposition, TABLE, 46-47, 77-78,  
 165, 169  
 generation, 25, 45, 49, 79, 104,  
 106, 142, 147, 177, 182, 185,  
 190; FIGURE, 50, 157, 168;  
 TABLE, 48, 52-53, 77-78, 108,  
 189, 195
- Electric power (Con't.)  
 generation, by energy source,  
 147, 148, 186, 188; TABLE,  
 46-47, 48, 77-78, 147, 189, 190,  
 195, 216  
 imports, TABLE, 46-47, 48, 77-78  
 peakload pricing, 109  
 prices, 86, 87, 93, 104-106, 109,  
 110, 146, 154, 190; TABLE,  
 40-41, 93, 94, 103, 104, 190  
 prices, by sector, TABLE, 84,  
 104, 109, 113, 166, 170  
 sales, 79; TABLE, 48, 190  
 sales, by sector, TABLE, 84, 108,  
 190  
 supply and demand, 25-26;  
 FIGURE, 157, 168; TABLE,  
 77-78  
 transmission losses, TABLE, 48,  
 77-78, 189  
 SEE ALSO Hydroelectric power;  
 Nuclear power.
- Electric power industry  
 SEE Electric utilities.
- Electric power projection series, 137  
 assumptions, 106, 154  
 long-term, 162, 172, 188;  
 FIGURE, 187  
 long-term, Series High, TABLE,  
 216  
 long-term, Series Low, TABLE,  
 216  
 long-term, Series Middle, 186;  
 TABLE, 94, 188, 189, 190, 195,  
 216  
 midterm, 81, 87, 91, 99, 104,  
 105-109, 111, 145, 148, 154;  
 TABLE, 147  
 midterm, Series High, 106;  
 TABLE, 93, 103, 108, 109  
 midterm, Series Low, 106;  
 TABLE, 93, 103, 108, 109  
 midterm, Series Middle, 86, 109;  
 TABLE, 93, 103, 104, 108, 109,  
 113  
 short-term, TABLE, 50  
 variables, 109
- Electric Power Research Institute  
 forecast, 147, 148; TABLE, 147
- Electric utilities:  
 capital expenditures, 45, 106, 109,  
 154  
 coal consumption, 37, 45, 73, 75,  
 79, 116, 184-185, 136, 137, 138,  
 147, 154; TABLE, 36, 52-53,  
 77-78, 149, 202  
 construction costs, 106, 137  
 energy consumption, 25, 86;  
 TABLE, 52-53  
 energy demand, FIGURE, 187  
 finance, 109



## Electric utilities (Con't.)

- fuel consumption, 49, 145;  
FIGURE, 112; TABLE, 52-53,  
64-65, 66-67, 108
- fuel prices, 132; TABLE, 40-41
- fuel stocks, 109; TABLE, 52-53
- fuel switching, 106, 154
- fuel use, 29, 30, 44, 45, 49, 81,  
87, 106; FIGURE, 107;  
TABLE, 46-47, 48, 52-53, 172,  
189, 190
- generating capacity, 45, 75, 106,  
177, 186; TABLE, 108, 189
- natural gas consumption, 45, 128,  
130, 132, 147, 148; TABLE, 36,  
46-47, 52-53, 72-73, 77-78, 126,  
131
- petroleum consumption, 45, 147;  
TABLE, 46-47, 52-53
- regulation, 72, 73-74, 106, 109
- reserve capacity, TABLE, 108
- SEE ALSO Geothermal  
powerplants; Hydroelectric  
powerplants; Nuclear  
powerplants; Solar powerplants.
- Electric vehicles, 97, 179; TABLE,  
176, 180
- Emerging technology  
SEE New energy technology.
- Employment, 139; TABLE, 141
- End use energy consumption  
SEE Energy consumption: end-  
use sector.
- Energy conservation:  
commercial sector, 99; TABLE,  
102
- industrial sector, 89, 105
- residential sector, 37, 99, 180;  
FIGURE, 98
- SEE ALSO World: energy  
conservation, and entries under  
specific energy sources.
- Energy consumption, 173  
Australia/New Zealand, TABLE,  
26, 27, 28, 29, 30
- by energy source, 173; TABLE,  
26, 27, 28
- Canada, 9; TABLE, 26, 27, 28,  
29, 30
- commercial sector, 26, 99, 102,  
103, 105, 167, 182; FIGURE,  
90, 171, 174; TABLE, 102, 103,  
104, 145, 146, 160, 216
- domestic, 83, 86, 140, 179;  
TABLE, 26, 27, 28, 30, 33, 44,  
46-47, 83
- electric utilities, 25, 86; TABLE,  
52-53
- end-use sector, 81, 83, 99, 156,  
161-162, 167, 173; FIGURE,  
157, 158, 164, 168, 174;  
TABLE, 83, 145, 162, 169

## Energy consumption (Con't.)

- free world, 7, 24, 25, 31-32;  
TABLE, 26, 27, 28, 29, 33, 34
- growth rates, 25-28, 102, 105;  
TABLE, 44
- industrial sector, 26-27, 86, 88,  
91, 105, 143, 156, 165, 170, 173,  
175; FIGURE, 90, 96, 171, 174;  
TABLE, 93, 94, 216
- Japan, 9, 25; TABLE, 26, 27, 28,  
29, 30, 33
- Organization for Economic  
Cooperation and Development  
countries, 8, 21, 22, 24, 25-26,  
27, 30; TABLE, 9, 23
- Organization of Petroleum  
Exporting Countries, 24, 27;  
TABLE, 30, 33
- residential sector, 26, 99, 102,  
105, 167, 180; FIGURE, 90, 98,  
171, 174; TABLE, 103, 104,  
145, 146, 216
- transportation sector, 26, 88,  
93-94, 99, 105, 165, 167, 172,  
178-179, 180; FIGURE, 90, 171,  
174; TABLE, 95, 97
- Western Europe, TABLE, 26, 27,  
28, 29, 30
- SEE ALSO World: energy  
consumption, and entries under  
specific energy sources.
- Energy consumption projection series:  
long-term, 162, 173; FIGURE,  
168
- long-term, Series High, 160
- long-term, Series Middle, 163
- midterm, 81, 87, 89, 93, 105, 140;  
TABLE, 83
- midterm, Series High, 103;  
FIGURE, 85; TABLE, 83, 93,  
95, 103, 141
- midterm, Series Low, 103;  
FIGURE, 85; TABLE, 83, 93,  
95, 103, 141
- midterm, Series Middle, 86, 103,  
143; FIGURE, 85, 90; TABLE,  
83, 93, 94, 95, 97, 102, 103, 104,  
141
- short-term, TABLE, 40-41
- SEE ALSO World energy  
projection series.
- Energy conversion, 161-162, 184,  
194-195; TABLE, 165, 169
- SEE ALSO Coal gasification;  
Coal liquefaction; Petroleum  
refineries.
- Energy demand:  
domestic, 43, 45, 86, 87, 99;  
TABLE, 48, 83, 84
- SEE ALSO World: energy  
demand.

## Energy demand projection series:

- long-term, 167; TABLE, 165, 169,  
172
- long-term, Series High, TABLE,  
165
- long-term, Series Low, TABLE,  
165
- long-term, Series Middle,  
TABLE, 162, 165, 172
- midterm, 22-23, 99; TABLE, 83,  
84, 115, 162, 172
- midterm, Series High, 86;  
TABLE, 83, 84
- midterm, Series Low, 86;  
TABLE, 83, 84
- midterm, Series Middle, 83, 86;  
TABLE, 83, 84, 162, 172
- short-term, TABLE, 48
- Energy exports  
SEE entries under specific  
energy sources.
- Energy/GDP ratio, 25; TABLE, 29
- Energy/GNP ratio, 44, 83, 105;  
FIGURE, 88, 89; TABLE, 44
- SEE ALSO Macroeconomic  
projections.
- Energy imports, 37, 44, 155, 156, 178;  
FIGURE, 164; TABLE, 36, 83, 115,  
141
- prices, 140
- SEE ALSO entries under specific  
energy sources.
- Energy imports projection series:  
long-term, 155, 156, 178
- midterm, TABLE, 83
- midterm, Series High, FIGURE,  
85; TABLE, 83, 141
- midterm, Series Low, FIGURE,  
85; TABLE, 83, 141
- midterm, Series Middle, FIGURE,  
85; TABLE, 83, 141
- short-term, TABLE, 36
- Energy industry:  
energy consumption, 138
- energy conversion losses, 161-162
- energy production, 138, 155
- SEE ALSO Coal industry;  
Electric utilities; Nuclear  
power industry; Synthetic fuels  
industry.
- Energy legislation, 4, 81, 82, 91, 135,  
138, 154
- SEE ALSO National Energy Act.
- Energy models, 3
- Energy price index, FIGURE, 89
- Energy price projection series:  
long-term, 163, 166-167; TABLE,  
166, 170
- long-term, Series High, TABLE,  
166
- long-term, Series Low, TABLE,  
166

- Energy price projection series (Con't.)  
 long-term, Series Middle, TABLE, 166, 170  
 midterm, 83, 146, 153; FIGURE, 89; TABLE, 84, 153  
 midterm, Series High, TABLE, 84, 93, 95, 103  
 midterm, Series Low, TABLE, 84, 93, 95, 103  
 midterm, Series Middle, 86; FIGURE, 89; TABLE, 84, 93, 94, 95, 97, 103, 104  
 short-term, 42; TABLE, 40-41  
 Energy prices, 29-30, 86, 139, 153; TABLE, 84, 153  
 commercial sector, 132; TABLE, 103, 145, 146, 166, 170, 190  
 consumer behavior, 82, 99, 102; TABLE, 102  
 industrial sector, 128, 130, 173, 178; TABLE, 84, 93, 94, 145, 153, 166, 170, 190  
 producer behavior, 82, 99, 169-170  
 residential sector, 130, 132, 180; TABLE, 40-41, 84, 103, 104, 145, 146, 153, 166, 170, 190  
 transportation sector, 179, 180; TABLE, 84, 95, 97, 166, 170  
 SEE ALSO World: energy prices; World oil prices.
- Energy production, 161-162, 194  
 domestic, 45, 86, 116, 167; TABLE, 30, 36, 76, 83, 144  
 Organization for Economic Cooperation and Development countries, 27; TABLE, 30  
 Organization of Petroleum Exporting Countries, TABLE, 30  
 SEE ALSO World: energy production.
- Energy projection series:  
 comparisons, 2, 5  
 methodology, 3  
 variables, 2  
 SEE ALSO Long-Term energy projection series; Midterm energy projection series; Short-Term energy projection series.
- Energy regulation, 43, 81-82  
 entitlements, 116  
 gasoline tilt, 43  
 price controls, 61-65
- Energy resources  
 SEE Energy supplies.
- Energy sector  
 SEE Energy industry.
- Energy supplies:  
 domestic, 44, 45, 153, 156, 197-198, 200; TABLE, 36, 46-47, 143, 152
- Energy supplies (Con't.)  
 long-term, 156, 161, 162; FIGURE, 157, 164, 168  
 midterm, 142, 149; FIGURE, 164; TABLE, 83, 143  
 short-term, 44, 45; TABLE, 36, 46-47
- Energy supply and demand:  
 long-term, 156, 160; FIGURE, 157; TABLE, 165, 169  
 midterm, TABLE, 83  
 short-term, TABLE, 46-47
- Energy Tax Act, 4
- Energy technology  
 SEE New energy technology.
- Enhanced recovery  
 SEE Natural gas: enhanced recovery; Petroleum: enhanced recovery.
- Environmental legislation, 109
- Environmental Protection Agency  
 New Source Performance Standards, 136, 138
- Ethanol, 197
- Europe:  
 nuclear power, 28-29  
 petroleum consumption, 15-16; FIGURE, 17; TABLE, 16  
 SEE ALSO Western Europe.
- Exxon forecast, 32, 33, 142, 143, 146, 148, 149, 150, 160; TABLE, 34, 144, 146, 149, 150, 151, 160
- Federal Energy Management Program, 99
- Federal Energy Regulatory Commission, 128
- Federal Water Pollution Control Act, 136
- Fluidized-bed combustion, 182  
 SEE ALSO Atmospheric fluidized-bed (AFB).
- Fossil fuels:  
 air emissions, 138
- France:  
 nuclear power, 28-29; TABLE, 31  
 petroleum consumption, TABLE, 22
- Free World:  
 economic growth, 8  
 economics, 21-22  
 energy consumption, 7, 24-25, 31-32; TABLE, 26, 27, 28, 29, 33, 34  
 energy forecasts, 21, 24, 32  
 energy imports, 22  
 petroleum consumption, 7, 15-16, 21, 24, 31-32; FIGURE, 17; TABLE, 16, 29, 33, 34
- Free World (Con't.)  
 petroleum import prices, 21-22  
 petroleum production, 21, 31-32; FIGURE, 20; TABLE, 18, 20, 33, 34  
 SEE ALSO World.
- Freezers  
 SEE Appliances.
- Fuel cells, 192; TABLE, 189, 195, 216
- Fuel consumption:  
 commercial sector, 182; TABLE, 175  
 electric utilities, 49, 144; FIGURE, 107; TABLE, 52-53, 64-65, 66-67, 108  
 industrial sector, 81, 178; TABLE, 175  
 residential sector, 180; FIGURE, 98; TABLE, 175  
 transportation sector, 97, 114; TABLE, 145, 175
- Fuel cycle  
 SEE Nuclear fuel cycle.
- Fuel oils  
 SEE Distillate; Residual fuels.
- Fuel shares:  
 Australia/New Zealand, TABLE, 26, 27, 28  
 Canada, TABLE, 26, 27, 28  
 commercial sector, 104; FIGURE, 101  
 free world, TABLE, 26, 27, 28  
 industrial sector, FIGURE, 92  
 Japan, TABLE, 26, 27, 28  
 Organization for Economic Cooperation and Development countries, TABLE, 26, 27, 28  
 residential sector, 104; FIGURE, 100  
 transportation sector, FIGURE, 96  
 United States, TABLE, 26, 27, 28  
 Western Europe, TABLE, 26, 27, 28
- Fuel use, FIGURE, 158  
 commercial sector, 81, 172, 181-182, 184; FIGURE, 101; TABLE, 176  
 electric utilities, 29-31, 44, 45, 49, 81, 87, 106; FIGURE, 107; TABLE, 46-47, 48, 52-53, 172, 189, 190  
 industrial sector, 5, 27, 29-30, 88, 91, 93, 173, 175, 177, 178; FIGURE, 92; TABLE, 176  
 residential sector, 81, 99, 146, 172, 180, 184; FIGURE, 98, 100; TABLE, 176  
 transportation sector, 97, 178-179; FIGURE, 98; TABLE, 176

- Gabon:  
 natural gas liquids production,  
 TABLE, 19  
 petroleum production, TABLE, 19
- GAO forecast  
 SEE General Accounting Office  
 forecast.
- Gas  
 SEE Gasoline; Natural gas.
- Gaseous fuels  
 SEE Coal gas; Natural gas;  
 Synthetic natural gas.
- Gasohol, 116  
 prices, 116  
 SEE ALSO Alcohol fuels.
- Gasoline:  
 consumption, 29-30, 36, 53, 97;  
 TABLE, 54-55, 58-59, 76,  
 77-78, 95  
 consumption rates, TABLE, 97  
 demand, 49, 56, 75; FIGURE, 58;  
 TABLE, 58-59, 60, 115  
 disposition, TABLE, 54-55, 58-59  
 exports, TABLE, 58-59  
 imports, TABLE, 58-59  
 leaded, 56-57, 114; TABLE,  
 58-59  
 prices, 40, 42, 43, 52, 56, 75, 86,  
 87, 95, 114, 166; TABLE,  
 40-41, 84, 95, 97, 115  
 primary stocks, TABLE, 58-59  
 production, TABLE, 58-59  
 regulation, 43  
 supply, 56; TABLE, 36, 58-59  
 unleaded, 57, 114; TABLE, 58-59
- Gasoline projection series:  
 long-term, 166  
 midterm, 87, 97, 114  
 midterm, Series High, TABLE,  
 95  
 midterm, Series Low, TABLE, 95  
 midterm, Series Middle, 86;  
 TABLE, 95, 97  
 short-term, TABLE, 60  
 SEE ALSO Petroleum products  
 projection series.
- Gasoline tilt  
 SEE Energy regulation: gasoline  
 tilt.
- GDP  
 SEE Gross Domestic Product.
- General Accounting Office forecast,  
 149
- Geothermal energy, 214  
 consumption, 177, 182, 183;  
 TABLE, 46-47, 175, 216  
 production, TABLE, 52-53
- Geothermal powerplants, 190-191;  
 TABLE, 189  
 generation, TABLE, 48, 77-78,  
 190, 195, 216
- German Federated Republic  
 SEE West Germany.
- GNP  
 SEE Gross National Product.
- Greenhouse effect, 138
- SEE ALSO Coal: environmental  
 aspects.
- Gross Domestic Product, 21-22  
 growth rates, 8, 24
- Gross National Product, 83, 87,  
 105, 139; FIGURE, 88;  
 TABLE, 38-39, 44  
 growth rates, 33, 105, 155, 156,  
 160-161, 167, 173, 175, 176,  
 180; TABLE, 44, 141, 143, 144,  
 156, 160  
 projections, 33, 37, 155, 161;  
 TABLE, 44, 141
- Heat pumps, 99, 104, 183; TABLE,  
 216
- Heating, 99, 102, 104, 181
- Heating oils  
 SEE Distillate.
- High-Btu gas, 194, 205, 207  
 consumption, 162  
 prices, 124, 131; TABLE, 129,  
 131  
 production, 124; TABLE, 126,  
 131, 207, 208, 216
- Household sector  
 SEE Residential sector.
- Hydroelectric power:  
 consumption, TABLE, 46-47  
 production, FIGURE, 107;  
 TABLE, 46-47, 52-53, 108, 147
- Hydroelectric powerplants:  
 capacity, 106; TABLE, 189  
 generation, TABLE, 36, 48, 76,  
 77-78, 108, 190
- Hydroliquefaction  
 SEE Coal liquefaction:  
 hydroliquefaction.
- Imports  
 SEE Energy imports.
- Income  
 See Disposable personal income;  
 Real disposable income.
- Incremental pricing of natural gas  
 SEE Natural gas: incremental  
 pricing.
- Indirect heat processes  
 SEE Industrial sector: indirect  
 heat processes.
- Indonesia, TABLE, 19, 20
- Industrial sector:  
 biomass energy consumption, 177,  
 178  
 capital expenditures, 138
- Industrial sector (Con't.)  
 coal consumption, 73, 81, 91, 116,  
 137-138, 144, 152-153, 177, 178;  
 FIGURE, 92; TABLE, 93, 137,  
 145, 146, 149, 175, 200, 202  
 coal prices, 91; TABLE, 84  
 direct heat processes, 173, 178;  
 TABLE, 176  
 distillate consumption, 91;  
 TABLE, 93, 94  
 distillate prices, TABLE, 93, 94  
 electric power consumption,  
 91-93, 105, 177, 178; FIGURE,  
 92; TABLE, 93, 94, 108, 145,  
 146, 175, 190  
 electric power generation, 177,  
 182-183; TABLE, 175, 195, 216  
 electric power prices, 91-93;  
 TABLE, 84, 93, 94, 109  
 energy conservation, 89, 105  
 energy consumption, 26-27, 86,  
 88-89, 91, 105, 143, 156, 165,  
 170, 173, 175; FIGURE, 90, 92,  
 171, 174; TABLE, 93, 94, 216  
 energy consumption rates,  
 TABLE, 94  
 energy demand, 167, 170, 172;  
 FIGURE, 159; TABLE, 160,  
 172  
 energy efficiency, 83, 173, 175  
 energy intensity, 88-89  
 energy prices, 128, 130, 173, 178;  
 TABLE, 84, 93, 94, 145, 146,  
 153, 166, 170, 190  
 fuel consumption, 81, 178;  
 TABLE, 175  
 fuel prices, 93, 145; TABLE, 84,  
 145, 146, 153  
 fuel switching, 81, 93, 105  
 fuel use, 5, 27, 29, 88, 91, 93,  
 173, 175, 177, 178; FIGURE,  
 92; TABLE, 176  
 geothermal energy consumption,  
 177  
 heavy oil consumption, 175;  
 TABLE, 172, 175  
 heavy oil prices, TABLE, 166,  
 170  
 indirect heat processes, 173, 178;  
 TABLE, 176  
 light oil consumption, 175;  
 TABLE, 172, 175  
 light oil prices, TABLE, 166, 170  
 liquid gas consumption, TABLE,  
 93, 94  
 liquid gas prices, TABLE, 93, 94  
 natural gas consumption, 87, 91,  
 128, 130, 144, 148, 176, 178;  
 FIGURE, 92; TABLE, 93, 94,  
 126, 131, 145, 146, 175  
 natural gas prices, 86, 87  
 petroleum consumption, 81, 91,  
 152-153; FIGURE, 92

- Industrial sector (Con't.)  
 petroleum products consumption, TABLE, 145, 146  
 residual fuels consumption, 29-30, 91; TABLE, 94  
 residual fuel prices, 91; TABLE, 84, 94  
 solar energy consumption, 177  
 synthetic fuels consumption, 176-177  
 SEE ALSO Energy industry.
- Industrial sector energy projection series:  
 assumptions, 91  
 comparisons, TABLE, 166, 170, 172  
 long-term, TABLE, 166, 170, 172, 175, 176  
 long-term, Series High, TABLE, 166, 175, 176  
 long-term, Series Low, TABLE, 166, 175, 176  
 long-term, Series Middle, TABLE, 166, 170, 172, 175, 176, 190  
 midterm, 81, 88, 89, 91, 139, 148, 154; TABLE, 84, 172  
 midterm, Series High, 87; TABLE, 84, 93  
 midterm, Series Low, 87; TABLE, 84, 93  
 midterm, Series Middle, 87, 88, 89, 93; FIGURE, 92; TABLE, 84, 93, 97, 172  
 variables, 91
- Industry  
 SEE Industrial sector.
- Inflation, 139  
 projections, 139  
 SEE ALSO Economic projections.
- International  
 SEE entries under World.
- Iran, TABLE, 18, 19, 20  
 Iraq, TABLE, 19  
 Italy, TABLE, 22
- Japan:  
 coal imports, 138  
 economics, 21; TABLE, 9, 23  
 energy consumption, 9, 25; TABLE, 26, 27, 28, 29, 30, 33  
 energy production, TABLE, 30  
 fuel shares, TABLE, 26, 27, 28  
 nuclear power, 28; TABLE, 31  
 petroleum consumption, 15-16, 21, 25; FIGURE, 17; TABLE, 16, 22, 33  
 petroleum import payments, 21-22; TABLE, 23
- Jet fuels:  
 consumption, 97, 145, 172; TABLE, 95  
 demand, TABLE, 115  
 prices, 97; TABLE, 40-41, 84, 95, 97, 115
- Kuwait, TABLE, 19
- LDC's  
 SEE Developing countries.
- Lease condensate:  
 prices, 131
- Libya, TABLE, 19  
 Lighting, TABLE, 176  
 Lignite, 202; TABLE, 200  
 Liquefied natural gas:  
 imports, 68, 126-128, 207; TABLE, 46-47, 72-73, 129, 150  
 production, TABLE, 126, 131
- Liquefied petroleum gases:  
 consumption, TABLE, 175  
 demand, TABLE, 172  
 prices, 163
- Liquid gas  
 SEE Liquefied natural gas;  
 Liquefied petroleum gases;  
 Natural gas liquids.
- Liquid natural gas  
 SEE Natural gas liquids.
- Liquid petroleum gas (LPG)  
 SEE Liquefied petroleum gases.
- LNG  
 SEE Liquefied natural gas.
- Long-Term energy projection series, 155, 156, 183; TABLE, 162, 204  
 assumptions, 155-156, 160, 163, 166-167, 172-173, 175, 178, 181; TABLE, 3, 160  
 comparisons, 155, 160, 167, 169-170, 172, 178; FIGURE, 157, 158, 168, 171; TABLE, 156, 160, 172  
 methodology, 4, 169-170  
 Series High, 155-156, 163, 166, 181; FIGURE, 164; TABLE, 175, 176, 180  
 Series Low, FIGURE, 164; TABLE, 175, 176, 180  
 Series Middle, 155-156, 161, 163, 166; FIGURE, 164; TABLE, 162, 172, 175, 176, 180, 189, 190  
 Series Middle, High Capital Costs, TABLE, 190  
 Series Middle, Nuclear Phase-out, 161
- Low-Btu gas, 182
- LP-Gas  
 SEE Liquefied petroleum gases.  
 Lubricating oils, 173; TABLE, 172, 175, 176
- Macroeconomic projections:  
 methodology, 87  
 midterm, 87, 138, 141, 155; TABLE, 141
- Macroeconomic variables, 87, 103, 160
- Magnetohydrodynamics (MHD):  
 electric power generation, 192; TABLE, 189, 195, 216
- Major fuel burning installations:  
 coal consumption, 72
- Manufacturing value added, 88, 89; FIGURE, 88
- Marine transportation:  
 energy consumption, 94, 172, 179; TABLE, 176, 180
- Massachusetts Institute of Technology  
 SEE MIT forecast.
- Medium-Btu gas:  
 prices, 124, 131; TABLE, 129, 131  
 production, 124, 131, 138, 176-177, 182; TABLE, 126, 131
- Metallurgical coal, 173, 178; TABLE, 176, 200, 202
- Methane, 124  
 Methanol, 197
- Mexico:  
 natural gas exports, 67, 68; TABLE, 126, 129, 131  
 natural gas prices, 133  
 natural gas production, 126  
 petroleum production, 19; TABLE, 20, 33
- MFBI  
 SEE Major fuel burning installations.
- Middle distillate fuel oils  
 SEE Distillate; Distillate projection series.
- Midterm energy projection series, 104, 114  
 assumptions, 2-3, 82, 86, 99, 142, 161, 172; TABLE, 3  
 comparisons, 31-34, 142-148, 155, 161, 169-170, 172, 173, 178, 182; FIGURE, 168; TABLE, 144, 145, 147, 151, 156, 172  
 methodology, 4, 32, 81, 82, 169  
 Series High, 82, 86, 151, 152; FIGURE, 85, 118, 164; TABLE, 83, 84, 93, 95, 103, 115, 144, 145  
 Series Low, 82, 86, 151, 152; FIGURE, 85, 118, 164; TABLE, 83, 84, 93, 95, 103, 115, 144, 145

### Midterm energy projection series (Con't.)

Series Middle, 82, 86, 151;  
FIGURE, 85, 88, 118, 164, 171;  
TABLE, 83, 84, 93, 94, 95, 97,  
102, 103, 104, 115, 144, 145, 172  
variables, 99, 138, 152

MIT forecast, 33; TABLE, 34

Motor gasoline  
SEE Gasoline.

National Coal Association forecast,  
79, 148; TABLE, 149

National Electric Reliability Council  
forecast, 147; TABLE, 147, 149

National Energy Act, 91

SEE ALSO Energy Tax Act;  
Natural Gas Policy Act;  
Powerplant and Industrial  
Fuel Use Act; Public Utilities  
Regulatory Policy Act.

National Environmental Policy Act,  
109

### Natural gas:

consumption, 24, 30-31, 68, 129,  
132, 162; FIGURE, 157, 158,  
168, 171, 174; TABLE, 46-47,  
72-73, 76, 77-78, 152, 162

consumption, commercial sector,  
99, 105, 130, 132, 154;  
FIGURE, 101; TABLE, 103,  
104, 126, 131, 145, 146, 175

consumption, electric utilities, 45,  
128, 132, 147, 148; TABLE,  
46-47, 52-53, 72-73, 77-78, 126,  
131

consumption, industrial sector, 87,  
91, 128, 130, 144, 148, 176-177,  
178; FIGURE, 92; TABLE, 93,  
94, 126, 131, 145, 146, 175

consumption rates, TABLE, 26,  
27, 28, 94, 104

consumption, refineries, TABLE,  
126, 131

consumption, residential sector,  
99, 104, 105, 130, 132, 154, 181;  
FIGURE, 98, 100; TABLE, 103,  
104, 126, 131, 145, 146, 175

consumption, transportation  
sector, 99, 179; TABLE, 175  
curtailments, 65, 68

demand, 24; TABLE, 72-73, 83,  
172

disposition, TABLE, 46-47, 72-73,  
165, 169

electric power generation, 106,  
110, 154; FIGURE, 107, 187;  
TABLE, 108, 110, 147, 189, 190

enhanced recovery, 149, 198, 207,  
213; FIGURE, 127, 211;  
TABLE, 131, 207, 208, 216

### Natural gas (Con't.)

imports, 67, 68, 124, 126, 132,  
162, 163, 207; TABLE, 46-47,  
72-73, 77-78, 83, 131, 143, 144,  
150, 152, 160, 165, 169, 195,  
207, 208

imports, prices, 124-128, 130, 156;  
TABLE, 129

incremental pricing, 65, 66, 87,  
128, 129, 130, 131, 132, 133,  
152, 154; TABLE, 129, 131

industrial surcharge, 87; TABLE,  
84, 129, 131

pipelines, 66-67, 124, 128;  
TABLE, 150

price controls, 61, 126-128

prices, 103, 124, 128-129, 130,  
133, 138, 144, 146, 152, 198;  
FIGURE, 199; TABLE, 40-41,  
84, 104, 129, 131, 143, 144, 153,  
166, 170

prices, commercial sector,  
TABLE, 103, 104, 129, 131,  
166, 170

prices, industrial sector, 65, 87,  
130; TABLE, 84, 93, 94, 129,  
131, 166, 170

prices, new interstate, 130, 132;  
TABLE, 129, 131

prices, new intrastate, TABLE,  
129, 131

prices, old interstate, 128, 130;  
TABLE, 129, 131

prices, old intrastate, 128;  
TABLE, 129, 131

prices, petroleum refineries,  
TABLE, 129, 131

prices, raw materials, TABLE,  
84, 153

prices, residential sector, 87;  
TABLE, 84, 103, 129, 131, 166,  
170

prices, retail, 87

production, domestic, 68, 74, 79,  
81, 86, 116, 124, 128, 130, 131,  
132, 133, 142, 205; FIGURE,  
127, 211; TABLE, 46-47, 72-73,  
76, 77-78, 83, 126, 131, 144,  
150, 162, 207, 208

refinery fuel, TABLE, 72-73,  
77-78

regulation, 61-65  
reserves, 117, 124, 132, 138;  
FIGURE, 125

resources, 134, 153; FIGURE, 125

stocks, TABLE 77-78

storage, TABLE 72-73

substitute fuel cap, 128, 130, 132,  
144; TABLE, 129, 131

supply, 156, 198, 200, 205, 207;  
FIGURE, 157, 168, 206;

TABLE, 36, 72-73, 76, 77-78,  
83, 143, 150, 152, 160, 165, 169,  
195, 207, 208

### Natural gas (Con't.)

supply and demand, TABLE, 83  
tight gas sands, 124, 149  
wellhead prices, 65-66, 86, 87,  
128, 131, 133, 148-149, 152;  
TABLE, 131

SEE ALSO Alaskan natural gas;  
Coal gasification; Liquefied  
natural gas; Natural Gas  
Policy Act; Powerplant and  
Industrial Fuel Use Act;  
Synthetic natural gas.

### Natural gas liquids:

prices, 131; TABLE, 131

production, 117, 123, 151, 204;  
FIGURE, 120, 121; TABLE, 19,  
54-55, 77-78, 122, 151, 204  
supply, 123; TABLE, 115

Natural Gas Policy Act, 61-67, 74,  
81, 91, 104, 128, 138

### Natural gas projection series:

long-term, Series High, 154;  
TABLE, 93, 208, 216

long-term, Series Low, 154;  
TABLE, 93, 208, 216

long-term, Series Middle,  
TABLE, 93, 195, 207, 208, 216  
midterm, 81, 91, 99, 128, 130,  
149; TABLE, 83, 84, 126, 129,  
150

midterm, Series High, 86-87, 131;  
FIGURE, 125; TABLE, 83, 84,  
103, 126, 129

midterm, Series Low, 86-87;  
FIGURE, 125; TABLE, 83, 84,  
103, 126, 129

midterm, Series Middle, 86, 87,  
131; FIGURE, 125, 127;  
TABLE, 83, 84, 94, 103, 104,  
126, 129

short-term, 128

variables, 105, 132

### Natural gas wells:

drilling, 133; FIGURE, 118

drilling rigs, 154

production, FIGURE, 127

Net energy/GNP ratio, 83

New energy technology, 180-181, 182,  
186, 188, 190-193; TABLE, 147,  
189, 216

economic aspects, 155, 156, 161,  
163, 170, 188-189, 194

legislation, 81

SEE ALSO entries under specific  
energy technologies.

### New Zealand

SEE Australia/New Zealand.

### NGPA

SEE Natural Gas Policy Act.

Nigeria, TABLE, 19

Nitrous oxide emissions, 138

Non-Communist countries

SEE Free World.

- Non-OECD countries, 24, 25; TABLE, 31
- North slope oil  
SEE Alaskan petroleum.
- Norway:  
petroleum production, TABLE, 22
- Nuclear fuel cycle, 207-208;  
FIGURE, 209
- Nuclear fuel storage  
SEE Spent fuel storage.
- Nuclear fuels, 207-208, 210  
consumption, 210  
costs, 113, 208; TABLE, 210  
supply, 113; TABLE, 160, 165,  
195 SEE ALSO Spent fuel  
storage; Uranium.
- Nuclear fusion, TABLE, 216
- Nuclear power, 185; TABLE, 188  
consumption, FIGURE, 157, 168;  
TABLE, 46-47  
demand, 24  
generation, 28, 29, 37, 45-49, 74,  
106, 110, 111, 142, 147, 162;  
FIGURE, 107, 187; TABLE, 31,  
36, 48, 76, 77-78, 108, 110, 143,  
147, 190  
international, 28-29; TABLE, 31  
production, 83-86, 111; TABLE,  
46-47, 52-53, 83, 144, 162  
supply, 162; FIGURE, 157, 168;  
TABLE, 169
- Nuclear power industry, 148  
capital expenditures, 111, 112  
economics, TABLE, 210
- Nuclear power projections series:  
assumptions, 113  
international, 29  
long-term, 161, 162  
long-term, Series High, 186  
long-term, Series Low, 186  
long-term, Series Middle,  
TABLE, 188, 189  
midterm, 29, 106, 111, 147-148;  
TABLE, 110, 149  
midterm, Series High, 112, 113;  
FIGURE, 112  
midterm, Series Low, 112, 113;  
FIGURE, 112  
midterm, Series Middle, 83,  
112-114; FIGURE, 112;  
TABLE, 113  
nuclear phaseout, 110, 113, 188,  
189; TABLE, 110, 113, 188, 190  
variables, 111
- Nuclear powerplants, 41, 112;  
TABLE, 111  
capacity, 28, 45, 186; TABLE,  
113, 152, 188,  
safety, 28, 74, 106, 110, 111,  
112-113
- Nuclear Regulatory Commission, 110,  
112, 113  
forecast, TABLE, 149
- Nuclear waste, 207-208  
disposal, 111, 113  
SEE ALSO Spent fuel storage.
- Ocean thermal energy conversion  
(OTEC):  
electric power generation, 191;  
TABLE, 189, 190, 195, 216
- OECD  
SEE Organization for Economic  
Cooperation and Development  
countries.
- Oil  
SEE Petroleum.
- Oil embargo  
SEE Arab oil embargo.
- Oil fields:  
leasing, 120, 133
- Oil shale, 123  
production, 119, 124, 212-213;  
FIGURE, 121; TABLE, 122,  
151  
supply, 198; TABLE, 115
- Oil wells, 120  
drilling, 117, 120, 133; FIGURE,  
118  
drilling rigs, 150, 154  
production, 131, 132-133;  
FIGURE, 127
- OPEC  
SEE Organization of Petroleum  
Exporting Countries.
- Organization for Economic  
Cooperation and Development  
countries:  
economics, 8, 21-22, 24-26, 27,  
29-30; TABLE, 9, 23  
energy conservation, 9  
energy consumption, 24-27, 30,  
31; TABLE, 26, 27, 28, 29, 30,  
33  
energy imports, 15, 21  
energy production, 27; TABLE,  
30  
fuel shares, TABLE, 26, 27, 28  
net energy trade, 21  
nuclear power, 28-29; TABLE, 31  
petroleum consumption, 21, 25,  
30-32; TABLE, 22, 29, 33  
petroleum import payments,  
21-22; TABLE, 23  
petroleum production, 18-19;  
TABLE, 20, 22
- Organization of Petroleum Exporting  
Countries:  
economics, 8, 24; TABLE, 9  
energy consumption, 24, 27;  
TABLE, 30, 33  
energy production, TABLE, 30  
net energy trade, 21
- Organization of Petroleum Exporting  
Countries (Con't.)  
petroleum consumption, 15, 21;  
FIGURE, 17; TABLE, 16, 22,  
33  
petroleum demand, 14, 30, 33-34  
petroleum production, 14-15, 16,  
18-19, 21, 32; FIGURE, 12, 20;  
TABLE, 18, 19, 20, 22, 33, 34  
price increases, 10-11, 33, 42, 81,  
83, 86; FIGURE, 12  
pricing behavior assumptions, 9,  
11, 14  
SEE ALSO Arab oil embargo.
- Pace forecast, 33, 78-79, 142, 143,  
146, 148, 150; TABLE, 34, 77-78,  
144, 146, 147, 149, 150, 151
- Petrochemical feedstocks, 173, 178  
demand, 91, 178; TABLE, 176  
prices, TABLE, 153
- Petroleum:  
consumption, Canada, 15;  
FIGURE, 17; TABLE, 16, 22, 29  
consumption, commercial  
sector, 99, 146  
consumption, developing  
countries, 15, 18, 21; FIGURE,  
17; TABLE, 16, 22  
consumption, domestic, 15-16, 21,  
30-32, 78, 86; FIGURE, 17,  
157, 158, 168, 171, 174;  
TABLE, 16, 33, 77-78  
consumption, electric utilities, 45,  
147; TABLE, 46-47, 52-53  
consumption, free world, 7,  
15-16, 21, 24, 31-32; FIGURE,  
17; TABLE, 16, 29, 33, 34  
consumption, industrial sector, 81,  
91, 152-153; FIGURE, 92  
consumption, international, 15,  
21, 24, 33-34; FIGURE, 17;  
TABLE, 16, 22  
consumption, Japan, 15-16, 21,  
25; FIGURE, 17; TABLE, 16,  
22, 33  
consumption, OECD, 21, 25,  
31-32; TABLE, 22, 29, 33  
consumption, OPEC, 15-16, 21;  
FIGURE, 17; TABLE, 16, 22,  
33  
consumption rates, 15; TABLE,  
26, 27, 28, 29  
consumption, residential sector,  
99, 146  
consumption, transportation  
sector, 86, 93, 99, 152-153, 179  
consumption, Western Europe,  
15-16; TABLE, 16, 22, 29  
decontrol, 51, 86  
demand, 24, 56, 114

## Petroleum (Con't.)

demand, domestic, 37, 51, 52, 56, 116, 124; FIGURE, 57; TABLE, 54-55, 56, 83  
demand, international, 152  
deregulation, 42  
disposition, TABLE, 46-47, 54-55, 165, 169  
electric power generation, 106, 109, 110, 154; FIGURE, 107, 187; TABLE, 108, 113, 147, 189, 190  
enhanced recovery, 117, 123, 150-151, 198, 204-205, 210, 212; FIGURE, 121, 211; TABLE, 122, 151, 204, 205  
entitlements, 116  
exploration, 81, 117  
exports, TABLE, 54-55, 77-78, 115  
import tariffs, 42, 116  
imports, 15, 21, 22, 37, 60-61, 78, 83, 86, 124, 142, 143, 152, 162, 163; TABLE, 36, 46-47, 54-55, 68, 70, 71, 76, 77-78, 83, 84, 115, 143, 144, 152, 160, 165, 169, 195, 204, 205  
imports, prices, 82, 86, 106, 155-156; TABLE, 143, 153  
price regulation, 43, 116  
prices, domestic, 37, 130, 133, 142, 143, 145, 198; FIGURE, 199; TABLE, 84, 143, 144, 153  
prices, international, 1-2, 5, 10-11, 14-16, 37, 40, 51-52, 130, 152, 179, 198; FIGURE, 13; TABLE, 38-39, 70, 71  
processing, 114  
production, domestic, 51, 74, 78, 81, 86, 116, 123, 130, 132, 133, 142, 150, 204; FIGURE, 211; TABLE, 20, 36, 46-47, 54-55, 76, 77-78, 83, 122, 144, 162, 204, 205  
production, international, 16, 18, 21, 32; FIGURE, 20; TABLE, 18, 19, 20, 22, 33, 34  
refiner's acquisition cost, 42, 43; TABLE, 38-39, 84, 143, 144, 153  
regulation, 43  
reserves, domestic, 116, 117, 132, 133, 150; FIGURE, 119; TABLE, 122, 151  
resources, 116-117, 120, 132-133, 134, 150, 153; FIGURE, 119; TABLE, 122, 151  
stock withdrawals, TABLE, 54-55, 76, 77-78  
stocks, 51; TABLE, 54-55  
supply, 7, 32, 35, 37, 51, 81, 156, 198; FIGURE, 157, 168, 203; TABLE, 36, 54-55, 76, 77-78, 115, 143, 152, 160, 165, 169, 195

## Petroleum (Con't.)

supply and demand, TABLE, 54-55, 83  
supply disruptions, 7, 10-11, 15-16  
wellhead prices, 86, 148-149; TABLE, 84, 143, 144, 153  
SEE ALSO Alaskan petroleum; Arab oil embargo; Oil fields; Oil shale; Oil wells; Petroleum products; Synthetic petroleum; Tar sands; World oil prices.  
Petroleum industry:  
windfall profits tax, 151  
Petroleum liquids:  
consumption, 179; TABLE, 162  
imports, 133  
production, 51, 117, 119, 133; FIGURE, 121; TABLE, 36, 76  
supply, FIGURE, 120  
SEE ALSO Oil shale; Petroleum; Petroleum products; Synthetic petroleum; Tar sands.  
Petroleum products, 204-205  
consumption, 36, 51, 91, 104, 178; TABLE, 54-55, 77-78, 152  
demand, 51, 75-78, 130; FIGURE, 57; TABLE, 83  
disposition, TABLE, 54-55  
exports, TABLE, 54-55, 77-78  
imports, 15, 61, 124; FIGURE, 69; TABLE, 46-47, 54-55, 77-78, 115  
prices, 42-43, 51, 86-87, 138; TABLE, 115, 166  
production, TABLE, 77-78  
regulation, 43  
SEE ALSO entries under specific petroleum products.  
Petroleum products projection series:  
long-term, 194, 204-205; TABLE, 172  
long-term, Series High, TABLE, 166  
long-term, Series Low, TABLE, 166  
long-term, Series Middle, TABLE, 166, 170, 204  
midterm, 86-87, 91, 114, 119; TABLE, 83  
midterm, Series High, TABLE, 83, 115  
midterm, Series Low, TABLE, 83, 115  
midterm, Series Middle, FIGURE, 120; TABLE, 83, 115  
short-term, 51-56  
SEE ALSO entries under specific petroleum products projections.  
Petroleum projection series, 150  
assumptions, 83, 86, 133, 150, 154  
comparisons, 149-150  
long-term, Series High, 163; TABLE, 205, 216

## Petroleum projection series (Con't.)

long-term, Series Low, TABLE, 205, 216  
long-term, Series Middle, 163; TABLE, 204, 205, 216  
methodology, 150  
midterm, 81, 94, 120, 123, 124, 145-146, 149, 150-151, 152-154; TABLE, 83, 151  
midterm, Series High, 82, 86, 117; FIGURE, 119; TABLE, 83, 115  
midterm, Series Low, 82, 86, 117; FIGURE, 119; TABLE, 83, 115  
midterm, Series Middle, 82, 86, 117; FIGURE, 119; TABLE, 83, 115  
short-term, TABLE, 56, 68  
variables, 132  
Petroleum refineries:  
capacity, 57, 114  
energy consumption, TABLE, 176  
feedstock, 117, 124  
gross margins, 116  
processes, 114  
processing gain, TABLE, 115  
production, 114  
Photovoltaics, 183-184; TABLE, 175, 195, 216  
SEE ALSO Solar energy.  
PIFUA  
SEE Powerplant and Industrial Fuel Use Act.  
Pipelines:  
energy consumption, 94; TABLE, 172, 175, 176  
SEE ALSO Alaskan Natural Gas Pipeline; Trans-Alaskan Pipeline.  
Population forecast, 24, 25, 87-88, 102, 155; TABLE, 141  
Power generation  
SEE Electric power: generation.  
Powerplant and Industrial Fuel Use Act, 4-5, 74, 81-82, 87, 91, 93, 106, 109, 110, 128, 134, 136, 138, 144-145, 147, 148  
Powerplants  
SEE Electric utilities; Geothermal powerplants; Hydroelectric powerplants; Nuclear powerplants; Solar - powerplants.  
Prices  
SEE Energy prices.  
Production  
SEE Energy production.  
Public Utilities Regulatory Policy Act, 109

Qatar, TABLE, 19

- Radioactive waste  
SEE Nuclear waste; Spent fuel storage.
- Rail transportation:  
energy consumption, 94, 172, 179;  
TABLE, 176, 180
- Rankine cycle engine, 184, 191
- Reactor fuels  
SEE Nuclear fuels.
- Reactors  
SEE Nuclear powerplants.
- Real disposable income, 139; TABLE, 141
- Refineries  
SEE Petroleum refineries.
- Refinery acquisition cost  
SEE Petroleum: refiner's acquisition cost.
- Refrigerators  
SEE Appliances.
- Regulation  
SEE Energy regulation.
- Renewable energy sources, 99, 188, 189, 190, 192-193; TABLE, 189, 190, 195, 216  
consumption, 162, 181  
economic factors, 189  
production, 162, 181  
supply, 165  
SEE ALSO Biomass; Geothermal energy; Hydroelectric power; Ocean thermal energy conversion (OTEC); Solar energy; Wind power; Wood.
- Reserves  
SEE Energy supplies; also entries under specific fuels.
- Residential buildings:  
energy conservation, 102, 181-182
- Residential sector:  
coal consumption, 194-195;  
TABLE, 145, 146, 175, 200, 202  
cooling, 181; FIGURE, 98;  
TABLE, 176  
distillate consumption, 180;  
FIGURE, 98, 100; TABLE, 103, 104  
distillate prices, TABLE, 84, 103, 104  
electric power consumption, 26, 146-147, 181; FIGURE, 98, 100; TABLE, 103, 104, 108, 145, 146, 175, 190  
electric power prices, TABLE, 84, 103, 104, 109  
energy conservation, 36-37, 99, 180  
energy consumption, 26, 99, 102, 105, 167, 180; FIGURE, 90, 98, 171, 174; TABLE, 103, 104, 145, 146, 216  
energy consumption rates, TABLE, 104
- Residential sector (Con't.)  
energy demand, 172, 181;  
FIGURE, 159; TABLE, 160, 172  
energy efficiency, 180-181  
energy prices, 130, 132, 180;  
TABLE, 40, 41, 84, 103, 104, 145, 146, 153, 166, 170, 190  
fuel consumption, 180; FIGURE, 98; TABLE, 175  
fuel prices, TABLE, 145, 146, 153  
fuel use, 81, 99, 145-146, 172, 180, 184; FIGURE, 98, 100;  
TABLE, 176  
geothermal energy consumption, 181, 183  
heating, 5, 181; FIGURE, 98  
light oil consumption, TABLE, 172, 175  
light oil prices, TABLE, 166, 170  
liquid gas consumption, 180;  
FIGURE, 98, 100; TABLE, 103, 104  
liquid gas prices, TABLE, 103, 104  
natural gas consumption, 99, 104, 105, 130, 132, 154, 181;  
FIGURE, 98, 100; TABLE, 103, 104, 126, 131, 145, 146, 175  
natural gas prices, TABLE, 84, 103, 104  
petroleum consumption, 99, 146  
petroleum products consumption, TABLE, 145, 146  
solar energy consumption, 181
- Residential sector energy projection series:  
assumptions, 180, 182  
comparisons, TABLE, 102, 166, 170, 172  
long-term, 180; TABLE, 166, 170, 172, 175, 176  
long-term, Series High, TABLE, 166, 175, 176  
long-term, Series Low, TABLE, 166, 175, 176  
long-term, Series Middle, TABLE, 166, 170, 172, 175, 176, 190  
midterm, 81, 99, 102, 105, 146;  
TABLE, 84, 172  
midterm, Series High, 87;  
TABLE, 84, 103  
midterm, Series Low, 87;  
TABLE, 84, 103  
midterm, Series Middle, 87;  
FIGURE, 100; TABLE, 84, 102, 103, 104, 172
- Residual fuels, 178  
consumption, 29-30, 37, 58, 116, 175; FIGURE, 101; TABLE, 66-67, 77-78, 93, 103, 104, 175  
consumption rates, 58; TABLE, 94, 104
- Residual fuels (Con't.)  
demand, 37, 60, 75, 116, 176;  
FIGURE, 63; TABLE, 115, 172  
disposition, TABLE, 54-55, 66-67  
exports, TABLE, 66-67  
imports, TABLE, 66-67  
prices, 42, 43, 60, 75, 91, 116, 130, 136, 144-145; TABLE, 93, 94, 103, 104, 115, 166, 170  
primary stocks, TABLE, 66-67  
production, TABLE, 66-67  
refinery output, TABLE, 66-67  
supply, 60; TABLE, 36, 66-67
- Residual fuels projection series:  
midterm, 116  
midterm, Series High, 91;  
TABLE, 93, 103  
midterm, Series Low, TABLE, 93, 103  
midterm, Series Middle, 91;  
TABLE, 93, 94, 103  
short-term, TABLE, 66
- Resources, renewable  
SEE Renewable energy sources.
- Saudi Arabia, TABLE, 19, 20
- Shale oil, 212-213  
environmental aspects, 204, 212-213  
production, 204, 205; TABLE, 204, 205, 216  
supply, TABLE, 160
- Shell Oil forecast, 33, 79, 150-151;  
TABLE, 34, 77-78, 151
- Short-Term energy projection series, 2  
assumptions, 35, 37; TABLE, 3, 38-39  
comparisons, 74, 78-79, 166;  
TABLE, 76, 77-78  
methodology, 3, 41  
variables, 35, 37; TABLE, 38-39
- SNG  
SEE Synthetic natural gas.
- Solar energy:  
consumption, 177-178, 181, 182;  
TABLE, 175  
power generation, 184, 191, 192;  
TABLE, 189, 195, 216  
Solar heating and cooling, 182, 183-184  
Solar hot water heating, 184  
Solar powerplants:  
generation, TABLE, 189, 190  
Space heaters, 99, 181; TABLE, 176  
SEE ALSO Residential sector: heating.
- Spent fuel storage, 113; TABLE, 210  
SEE ALSO Nuclear waste.
- Standard Oil forecast, 33; TABLE, 34
- Stanford Research Institute forecast, 33; TABLE, 34



Stoves  
 SEE Appliances.  
 Strategic Petroleum Reserve, TABLE, 70  
 Subbituminous coal, TABLE, 200  
 prices, TABLE, 84, 137, 143, 144, 153  
 production, 134  
 Substitute fuel cap  
 SEE Natural Gas: substitute fuel cap.  
 Sulfur oxide emissions, 72, 138  
 Surface Mining Control and Reclamation Act, 134-135  
 Syncrude  
 SEE Synthetic petroleum.  
 Synthetic fuels, 138, 148, 193-196; TABLE, 216  
 production, 81, 138  
 SEE ALSO Coal gasification;  
 Coal liquefaction; Oil shale;  
 Synthetic natural gas;  
 Synthetic petroleum.  
 Synthetic fuels industry, 124  
 coal consumption, TABLE, 149  
 economic aspects, 163, 193-194  
 Synthetic natural gas, 200, 205, 207; TABLE, 207, 208, 216  
 consumption, 162  
 prices, TABLE, 129, 131  
 production, FIGURE, 127; TABLE, 72-73, 77-78, 150  
 supply, TABLE, 160  
 SEE ALSO Coal gasification.  
 Synthetic petroleum, 193, 194, 200, 202, 204, 205  
 prices, 163, 165  
 production, 138, 163; TABLE, 126, 131, 195, 204  
 supply, TABLE, 160  
 SEE ALSO Coal liquefaction.

Tar:  
 production, 116  
 Tar sands, 123  
 production, 119; FIGURE, 121; TABLE, 122, 151  
 supply, TABLE, 115  
 Tenneco forecast, 148; TABLE, 150, 151  
 Three Mile Island, 106, 110-111, 113, 154, 167  
 SEE ALSO Nuclear powerplants: safety.  
 Tight sands  
 SEE Natural gas: tight gas sands.  
 Trans-Alaskan pipeline, 122-123

Transportation sector:  
 coal consumption, 152-153  
 distillate consumption, 94; FIGURE, 98; TABLE, 95, 97, 145, 146  
 distillate prices, TABLE, 84, 95, 97  
 electric power consumption, 99, 179; TABLE, 175, 190  
 energy consumption, 26, 81, 93, 94, 99, 105, 165-166, 167, 172, 178-179; FIGURE, 90, 171, 174; TABLE, 95, 97  
 energy consumption rates, TABLE, 97  
 energy demand, 167, 179; FIGURE, 159; TABLE, 172, 180  
 energy prices, 179, 180; TABLE, 84, 95, 97, 166, 170  
 fuel consumption, 97, 114; TABLE, 145, 175  
 fuel efficiency, 99, 179  
 fuel prices, 95, 97, 145; TABLE, 145, 146, 153  
 fuel use, 97, 178-179; FIGURE, 98; TABLE, 176  
 gasoline consumption, 94; FIGURE, 96; TABLE, 95, 97, 145, 146  
 gasoline prices, 95; TABLE, 84, 95, 97  
 heavy oil consumption, TABLE, 172, 175  
 heavy oil prices, TABLE, 166, 170  
 jet fuel consumption, 179; FIGURE, 96; TABLE, 95, 97, 145, 146  
 jet fuel prices, TABLE, 84, 95, 97  
 light oil consumption, TABLE, 172, 175  
 light oil prices, TABLE, 166, 170  
 natural gas consumption, 99, 179  
 petroleum consumption, 86, 93, 99, 152-153, 179

Transportation sector energy  
 projection series:  
 assumptions, 94  
 comparisons, TABLE, 170, 172  
 long-term, TABLE, 166, 170, 172, 175, 176, 180  
 long-term, Series High, TABLE, 166, 175, 176, 180  
 long-term, Series Low, TABLE, 166, 175, 176, 180  
 long-term, Series Middle, TABLE, 166, 170, 172, 175, 176, 180, 190  
 midterm, 81, 93, 94-95, 97, 99, 114, 145, 154; TABLE, 84, 172

Transportation sector energy (Con't.)  
 midterm, Series High, 97; TABLE, 84, 95  
 midterm, Series Low, 97; TABLE, 84, 95  
 midterm, Series Middle, 97; FIGURE, 96; TABLE, 84, 95, 97, 172  
 variables, 94

Trucks:  
 diesel-fueled, 97  
 energy consumption, 94, 179; TABLE, 176, 180  
 fuel efficiency, 95  
 vehicle miles traveled, 95, 179

United Arab Emirates, TABLE, 19

United Kingdom:  
 nuclear forecasts, TABLE, 31  
 petroleum consumption, TABLE, 22  
 petroleum production, TABLE, 22

United States of America:  
 economics, 21, 61, 87; TABLE, 9, 23, 70, 71  
 energy consumption, 83, 86, 134, 173; FIGURE, 85, 88; TABLE, 26, 27, 28, 29, 30, 33, 44, 46-47, 83  
 energy efficiency, 44, 83  
 energy imports, 15, 21-22, 44-45, 60-61, 86; TABLE, 36, 76, 83  
 energy production, 45, 83, 116, 167; TABLE, 30, 36, 76, 83, 144  
 energy supply, 45, 83, 86, 116; TABLE, 36, 46-47, 76, 83  
 fuel shares, TABLE, 26, 27, 28  
 Gross Domestic Product, 21-22  
 Gross National Product, 83, 87; TABLE, 38-39, 44  
 natural gas demand, 116; TABLE, 83  
 natural gas supply, 68; TABLE, 72-73, 77-78, 83  
 petroleum consumption, 15-16, 21, 30, 31-32, 78; FIGURE, 17, 157, 158, 168, 171, 174; TABLE, 16, 22, 29, 33, 46-47, 54-55, 77-78  
 petroleum demand, 52, 56, 75-78, 116; FIGURE, 57; TABLE, 54-55, 56, 83  
 petroleum import prices, 61, 86, 156; TABLE, 23, 70, 71

- United States of America (Con't.)  
 petroleum imports, 15, 21-22, 37, 60-61, 78, 83, 86, 124, 142, 143, 152, 162, 163; TABLE, 36, 46-47, 54-55, 68, 70, 71, 76, 77-78, 83, 84, 115, 143, 144, 152, 160, 165, 169, 195, 204, 205  
 petroleum production, 21, 44, 51, 74, 78; TABLE, 20, 22, 33, 36, 46-47, 54-55, 76, 77-78, 83
- Unleaded gasoline  
 SEE Gasoline: unleaded.
- Uranium, FIGURE, 199  
 consumption, 106  
 demand, 113, 210  
 electric power generation, 106  
 enrichment, 208; TABLE, 210  
 reserves, 198, 208, 210  
 supplies, 200, 208  
 SEE ALSO Nuclear fuels.
- USA  
 SEE United States of America.
- Utilities  
 SEE Electric utilities.
- Venezuela, TABLE, 19
- Water heaters  
 SEE Appliances.
- Waxes, TABLE, 172, 175, 176
- Weather, 37, 38, 43, 49, 53, 58, 60; TABLE, 38-39, 48, 50, 56, 60, 64, 66, 68, 71
- Well drilling  
 SEE Natural gas wells: drilling;  
 Oil wells: drilling.
- West Germany:  
 petroleum consumption, TABLE, 22
- Western coal, 136  
 environmental aspects, 72, 73, 135  
 prices, 136  
 production, 72, 134, 154, 200, 202; FIGURE, 135, 201; TABLE, 137, 200, 202  
 transportation, 154
- Western Europe:  
 coal imports, 138  
 economics, 21-22  
 energy consumption, TABLE, 26, 27, 28, 29, 30  
 energy production, TABLE, 30  
 fuel shares, TABLE, 26, 27, 28  
 nuclear power, TABLE, 31  
 petroleum consumption, 15-16; TABLE, 16, 22, 29  
 petroleum import payments, 21-22; TABLE, 23  
 petroleum production, TABLE, 20, 22
- Westinghouse forecast, TABLE, 149
- Wind power:  
 electric power generation, 191; TABLE, 189, 190, 195, 216
- Windfall profits tax  
 SEE Petroleum industry:  
 windfall profits tax.
- Wood, 177
- World:  
 economics, 7, 21-22, 32, 33  
 energy conservation, 9  
 energy consumption, 24, 32; TABLE, 26, 27, 28, 29, 30, 33  
 energy demand, 22-23  
 energy prices, 155-156  
 energy production, TABLE, 30  
 petroleum consumption, 15, 21, 24, 31-32; FIGURE, 17; TABLE, 16, 22, 29, 33, 34  
 petroleum import payments, TABLE, 23
- World (Con't.)  
 petroleum production, 19; FIGURE, 20; TABLE, 18, 22, 33
- World energy projection series, 7  
 assumptions, 7-8, 9-10, 87, 89  
 comparisons, TABLE, 33, 34  
 methodology, 10, 87  
 variables, 87
- World oil prices, 106, 124, 130, 135, 142, 150  
 economic impact, 87, 106, 126, 139, 141, 148, 151-152  
 energy market impact, 81, 82, 87, 166-167, 178; TABLE, 94, 97, 102, 104  
 forecasts, 10-11, 14-15, 32, 33-34, 37, 82, 86, 155-156, 160, 161, 163, 182; FIGURE, 13; TABLE, 10, 23, 33, 156, 160, 166, 170  
 scenario, 2-3, 5, 155-156, 160, 178; TABLE, 10  
 sensitivity analysis, 14-15, 29-31, 130, 165, 179; FIGURE, 164; TABLE, 14, 32, 180
- World petroleum projection series:  
 assumptions, 11, 132; TABLE, 10  
 comparisons, 31-34; TABLE, 33  
 methodology, 11, 32, 42  
 midterm, 132, 139  
 midterm, Series High, 132, 139, 140  
 midterm, Series Low, 132, 139, 140  
 midterm, Series Middle, 132, 139, 140, 148  
 variables, 42
- World regions  
 SEE Communist countries;  
 Developing countries; free world; Non-OECD countries; Organization for Economic Cooperation and Development countries; Organization of Petroleum Exporting Countries.

**U.S. Department of Energy  
Energy Information Administration  
Office of Energy Information Services  
1726 M St., N.W.  
Washington, D.C. 20461**

**OFFICIAL BUSINESS  
PENALTY FOR PRIVATE USE, \$300**

**FIRST-CLASS MAIL  
POSTAGE & FEES PAID  
U.S. DEPT. OF ENERGY  
PERMIT NO. G 20**

**FIRST CLASS MAIL**