

# Fact Sheet 1.5: Roadway Lights, Poles, and Signage

The mitigation objective of this Fact Sheet is to keep critical transportation networks working that are needed to move public safety resources and supplies during and after a disaster by reducing damage to roadway lights, poles, traffic signals, and signs, all of which help to control traffic on roadways.

Table 1.5.1 identifies some common mitigation strategies that can help improve the performance of these structures during hurricanes and floods.

**Table 1.5.1. Common Mitigation Strategies for Various Types of Damage**

| <b>Solutions and Options</b>   | <b>Wind</b> | <b>Erosion and Scour</b> | <b>Flooding and Washout</b> | <b>Debris Impact</b> |
|--|-------------|--------------------------|-----------------------------|----------------------|
| <b>Mitigation Solution: Traffic Signal Controllers</b>                       |             |                          |                             |                      |
| Option 1: Elevate Controller Housing   |             | ✓                        | ✓                           |                      |
| Option 2: Provide Backup Power Supply  | ✓           |                          |                             |                      |
| <b>Mitigation Solution: Traffic Signal Support Structures and Luminaires</b> |             |                          |                             |                      |
| Option 1: Install Mast Arm Poles   | ✓           |                          |                             |                      |
| Option 2: Strengthen Poles and Improve Foundations                           | ✓           |                          |                             | ✓                    |
| Option 3: Install Vibration Dampers  | ✓           |                          |                             |                      |
| <b>Mitigation Solution: Roadway Sign Support Structures</b>                  |             |                          |                             |                      |
| Option 1: Strengthen Roadside Signs  | ✓           | ✓                        |                             | ✓                    |
| Option 2: Increase Foundation Installation Depth                             | ✓           | ✓                        |                             |                      |
| Option 3: Improve Foundations  | ✓           | ✓                        |                             |                      |



## Mitigation Solution: Traffic Signal Controllers

Traffic signal controllers are electrical systems that run traffic signals. Typically, they are installed in a controller cabinet that is mounted on the ground on a concrete pad or on a pole mount off the ground. Traffic signal controllers may be damaged by flooding or erosion. In fact, storm surge or flooding over an electrical signal controller can destroy the controller, shutting down the function of the traffic signal.

### Option 1: Elevate Controller Cabinets

Raising ground-level and pole-mounted traffic signal controller cabinets above the estimated level of the design flood elevation will reduce contact with floodwaters (Figure 1.5.1), keeping the traffic signal working during and after a hurricane or flood.

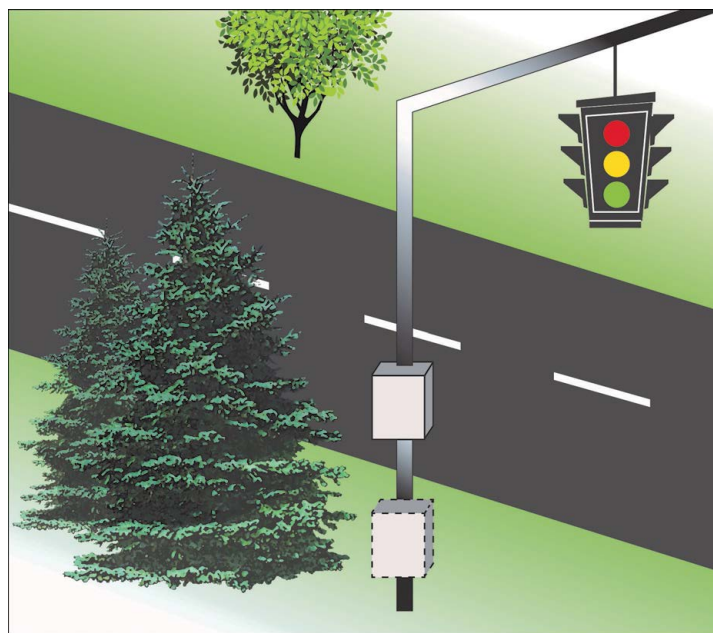
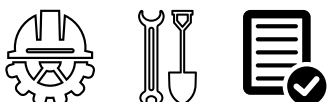

**Figure 1.5.1. Elevating signal controller cabinets protects them against flooding.**

When evaluating this option, keep these considerations in mind:

- A pole-mounted cabinet is easily removed and reattached to the pole at a higher position.
- Ground-level signal controller cabinets may be raised and anchored on a concrete pedestal or steel post.
- State or local departments of transportation may have height restrictions on cabinets. Verify if height restrictions are in place and, if so, what the restrictions are.

### CONSIDERATIONS:



## Option 2: Provide Backup Power Supply

Loss of a traffic signal due to a power outage can result in a potentially dangerous situation, causing traffic accidents, gridlock, and blocked routes for emergency vehicles. Taking steps to provide backup power to traffic signals can help to mitigate these potential problems.

When evaluating this option, keep these considerations in mind:

- Installing an uninterruptible power supply (UPS) at intersections with traffic signals will allow signals to continue operating when electrical power is lost from high wind gusts or storm surge. A UPS system provides emergency power to the traffic signal controller cabinet from a backup battery, enabling continued operation.
- Because a UPS is battery powered, this solution is short term, providing power only for a few hours to 24 hours, depending on the system and the battery.
- Installing quick-connects allows a portable generator to be installed to power traffic signals.
- Generators used to power traffic signals must be refueled regularly. When they are, they can provide power for several days to weeks until electricity is restored.

### CONSIDERATIONS:

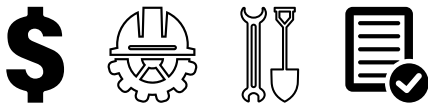

## Mitigation Solution: Traffic Signal Support Structures and Luminaires

Traffic signals may include traffic lights, crosswalk signals, etc. They may be mounted in several different ways, including:

- Luminaires are overhead lights mounted in combination on traffic signal poles or mounted on individual poles.
- Traffic signal support structures and luminaires may be cantilevered (a single pole with a truss or steel arm that extends horizontally over the roadway) or non-cantilevered (a truss or strain cable that spans over the roadway and is supported by one strain pole on each side).
- Signals also may be mounted to bridge structures and overhead sign trusses.
- Traffic signal support structures are sensitive to vibration and forces caused by high winds.
- Damage from high wind pressure and windborne debris strikes can be reduced by strengthening poles to increase resistance.
- Damping or installing lighter-weight signals and lights will reduce vibration.

### Option 1: Install Mast Arm Poles

Strain poles can be made from wood, steel or concrete. Strain poles that support overhead traffic signals on suspended cables are especially prone to damage because hangers and other connections are subjected to greatly increased wind. Replacing strain cables and strain poles with a cantilevered mast arm pole will reduce damage from hurricane-force winds (Figure 1.5.2).

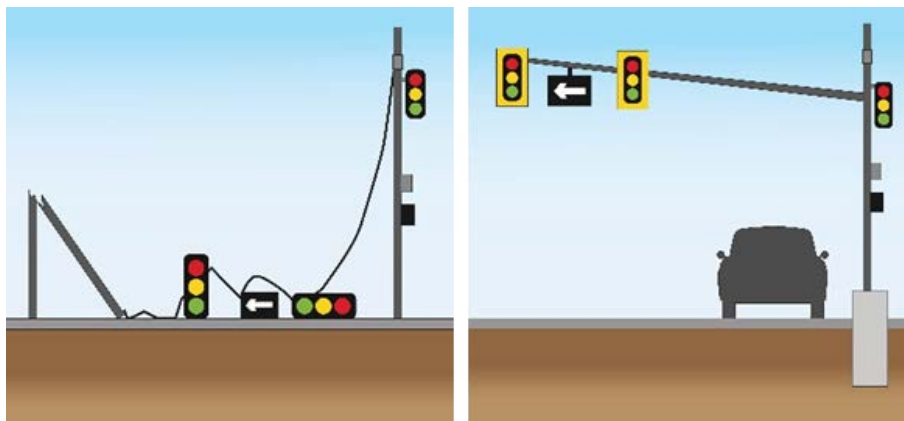
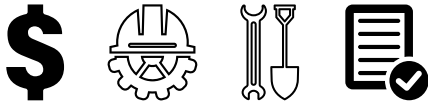

**Figure 1.5.2. Mast arm poles protect traffic signals against wind damage.**

When evaluating this option, keep these considerations in mind:

- When designed and constructed correctly, mast arm poles are an effective form of mitigation for strain poles.
- The success of this option can be increased when combined with other measures, such as improving pole foundations.

#### CONSIDERATIONS:



### Option 2: Strengthen Poles and Improve Foundations

Strengthening poles can be done either by replacing a damaged pole with one of a similar material having a higher-class rating or by using a pole with a higher strength for the same class rating. A well-supported pole must be anchored to a properly designed and constructed foundation.

When evaluating this option, keep these considerations in mind:

- Instead of replacing damaged strain poles with the same pole, a stronger pole should be chosen.
- The foundation of the pole should be designed to avoid blowing down in the wind or collapsing when the ground is saturated.
- Wind pressure causes uplift and drag forces on the foundation and the pole anchors. Make sure that the foundation will not be lifted out of the ground and the pole is securely anchored to the foundation.
- Adding resistance into the design of the foundation reduces the chance of pole failure.

#### CONSIDERATIONS:



### Option 3: Install Vibration Dampers

Vibration dampers, such as a damping plate, can be installed on the cantilever arm to reduce mast arm sway (Figure 1.5.3).

- Vibration occurs due to the pole's signal loading and wind pressure.
- Determine the appropriate size and location for the dampening plate for each assembly.

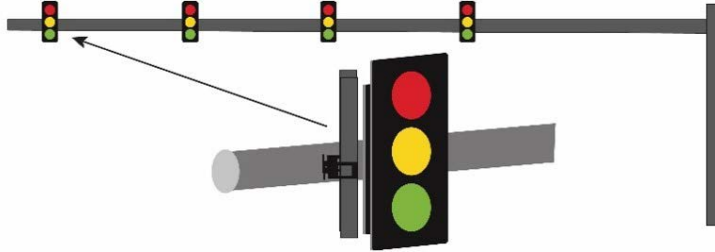

**Figure 1.5.3. Vibration dampers can protect poles and signals against wind vibration damage.**

#### CONSIDERATIONS:

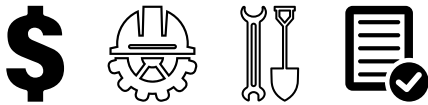

## Mitigation Solution: Roadway Sign Support Structures

High wind pressures and impact forces from windborne debris cause breakage or blow-off of roadside signs and supports. Reduce the risk of damage from high winds and windborne debris by reinforcing or strengthening roadside signs and supports to increase their resistance to these forces.

### Option 1: Strengthen Roadside Signs

Strengthen overhead and roadside signs by replacing panels and supports with a stronger system including:

- Use improved sign construction materials such as aluminum and high-strength plastics.
- Use multiple support posts or adding structural framing behind the sign to reduce sign failure.
- Use stronger panels and fasteners.
- Increase the size and number of connectors and fasteners.
- Employ redundant, strong, corrosion-resistant connections and fasteners to support overhead and roadside signs to prevent blow-off.
- Consider designing for higher wind speeds.

#### CONSIDERATIONS:

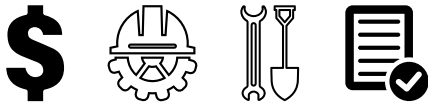

## Option 2: Increase Foundation Installation Depth

Increasing pole embedment will better protect sign poles from erosion and failure (Figure 1.5.4).

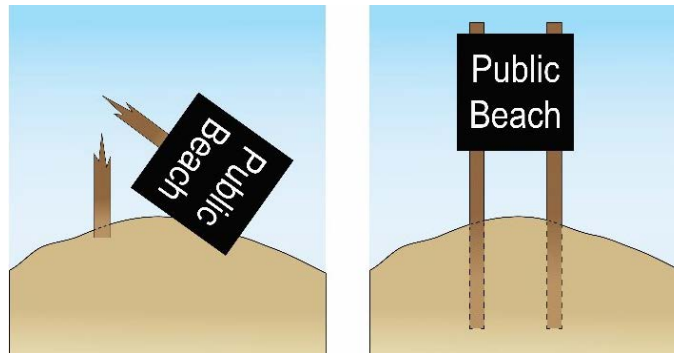

**Figure 1.5.4. Increase sign connectors and pole embedment depth. Left image is before mitigation occurs. Right image is after mitigation occurs.**

- Sign poles must be properly embedded or supported on engineered foundations to avoid overturning or collapse.
- Depth of embedment will vary based on sign height, width, and type of material. State DOT regulations and state building codes should include additional information about requirements.

### CONSIDERATIONS:





### Option 3: Improve Foundations

Engineered sign foundations should be appropriate for the design load for the sign.

- Types of concrete foundations that might be used include drilled shafts and piles (deep foundations) or spread footings (shallow foundations).
- Typically, deep foundations could be used for large signs, critical signs, or signs expected to be subject to heavy wind or debris loads.
- Screw-in helical anchors consist of a pipe or tube shaft and round helix plates typically made from galvanized steel (Figure 1.5.5).
  - They are screwed into the ground at a specified angle using rotary equipment until the design depth is reached.
  - Helical anchors are typically used for light poles, pole top-mount traffic signal supports and other small structures.
  - Helical anchors may provide a more cost-effective option to concrete drilled shafts and piles.

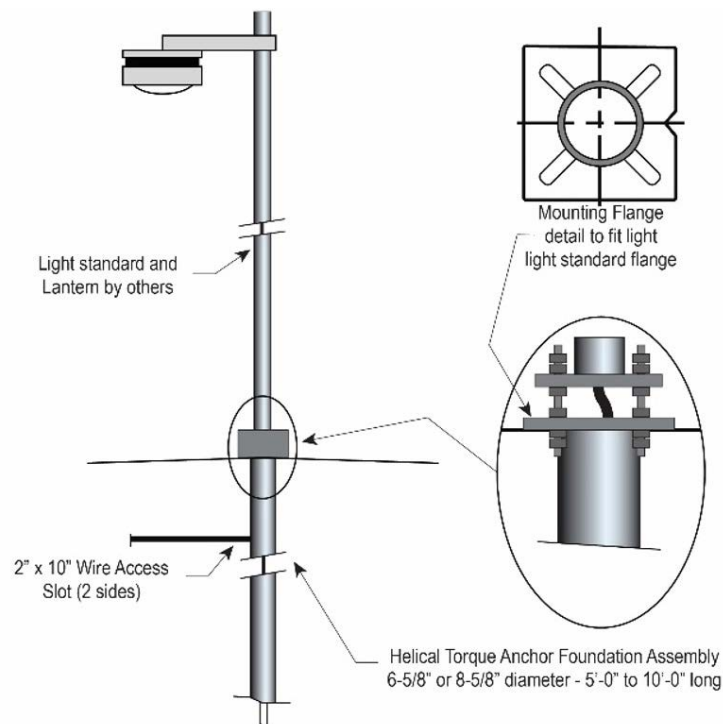

**Figure 1.5.5. Helical anchors can be used as foundation support for street signs and light poles.**

#### CONSIDERATIONS:



**REFERENCES:**

AASHTO LRFDLTS, *Standard Specifications for Structural Supports for Highway Signs, Luminaries, and Traffic Signals* (current edition).

Federal Emergency Management Agency. 2007. FEMA P-543, *Design Guide for Improving Critical Facility Safety from Flooding and High Winds: Providing Protection to People and Buildings*. Available at: [https://www.fema.gov/sites/default/files/2020-08/fema543\\_design\\_guide\\_complete.pdf](https://www.fema.gov/sites/default/files/2020-08/fema543_design_guide_complete.pdf)

State Building Codes.

State Department of Transportation Geotechnical Manuals.

State Department of Transportation Traffic Sign Design Manuals.