

~~December 2017~~ September 2020
CMDh/069/1999, Rev. ~~5~~6

Extension applications in Mutual Recognition and Decentralised Procedures

Member states recommendations

This document was produced by the CMDh in order to facilitate and harmonise the regulatory issues for submission of applications under Annex I of Regulation (EC) No 1234/2008.

1. Extracts from European Legislation: Commission Regulation (EC) No 1234/2008

The changes to an existing marketing authorisation listed in Annex I of Regulation (EC) No 1234/2008 will be regarded as an extension application as referred to in Article 2 of Regulation (EC) No 1234/2008.

According to Article 19 of the Regulation (EC) No 1234/2008, the extensions of marketing authorisations which fulfil the conditions set out in Annex I to this Regulation shall be evaluated in accordance with the same procedure as for the initial marketing authorisation to which it relates.

An extension shall either be granted a marketing authorisation in accordance with the same procedure as for the granting of the initial marketing authorisation to which it relates or be included in that marketing authorisation.

Prerequisite: The marketing authorisation holder (MAH) is the same as the MAH of the existing marketing authorisation.

More information about extension applications can be found in the following communications from the European Commission:

- Communication from the Commission — Guideline on the operation of the procedures laid down in Chapters II, III and IV of Commission Regulation (EC) No 1234/2008 concerning the examination of variations to the terms of marketing authorisations for medicinal products for human use and veterinary medicinal products (2009/C 323/04) of 31 December 2009 (see Section 2.4),
 - Commission communication on the Community marketing authorisation procedures for medicinal products (98/C 229/03) of 22 July 1998 (see Section E9).
-

2. General principles

- An extension of the existing marketing authorisation will have to be granted by the national competent authority. The name of the medicinal product will be the same for the extension as it is for the existing marketing authorisation of the medicinal product.
- The existing marketing authorisation referred to is authorised in the Member state(s) where the application is submitted (so reference to a product authorised in another member state is not possible for a line extension).
- When a medicinal product has been granted an initial marketing authorisation, any extension shall be considered as belonging to the same global marketing authorisation, in particular for the purpose of the rules on data and market protection.
- The first authorised medicinal product in the particular line, so-called "originator product" for the purpose of this document, is defined as the first product for which a marketing authorisation was granted to a given marketing authorisation holder (MAH) for a given active substance. The marketing authorisation of an originator product could be based on any legal basis according to Directive 2001/83/EC, i.e. stand-alone applications according to article 8.3 and articles 10, 10a, 10b or 10c.
- The changes mentioned in the Annex I of the Regulation (EC) No 1234/2008 are considered as extensions of an existing marketing authorisation and defined by an originator product. Without prejudice of the provisions of this Annex, a new application for an extension should be made in accordance with the provisions of article 8.3 and articles 10, 10a, 10b or 10c of Directive 2001/83/EC. The extension application has to have the same legal basis as the original product (see also Paragraph IV).
- Where a marketing authorisation has been granted to an orphan designated medicinal product by the Community (through the centralised procedure) or by all Member States (through the mutual recognition procedure), the Member States shall not, for a period of 10 years after the granting of this marketing authorisation, accept an application to extend an existing marketing authorisation, for the same therapeutic indication, in respect of a similar medicinal product (Article 8(1) - Regulation (EC) No 141/2000).
- The provisions of the mutual recognition or the decentralised procedure can be applied to extension applications. This is the choice of the MAH either to submit an extension application through a national procedure and afterwards to start a mutual recognition procedure or to submit directly an extension application through a decentralised procedure for a medicinal product already authorised through MRP/DCP. The RMS for the extension application will be the same as for the already approved product unless there is a good rationale for the applicant to change.
- When the applicant chooses the mutual recognition or the decentralised procedure for an extension application, there is no longer the possibility to resubmit a national procedure after withdrawal of this application.
- For medicinal products approved through purely national marketing authorisation procedures, the MAH will have to harmonise the whole dossier and the product information (SmPC, PL, Labelling) in all concerned Member States before submitting an extension application through a mutual recognition or decentralised procedure.
- Changes to the active substance(s) which will lead to consider the active substance as a new active substance will not be considered as an extension (see also definition of a new active substance in

Notice to Applicants, Volume 2A, Chapter 1- Appendix III). In these cases, a new dossier should be provided. The consequences are the following:

- For those changes considered as extensions of marketing authorisations granted through a national procedure, national procedure and mutual recognition/decentralised procedure are acceptable;
- For those changes of marketing authorisations which are not considered as extensions but as new marketing authorisation applications (i.e. new active substances), the mutual recognition/decentralised procedure only is acceptable.
- Applications for new pharmaceutical forms and new routes of administration for products protected either by a supplementary protection certificate (SPC) or by a patent which qualified for the granting of the SPC, shall only be considered valid if they include the results of a Paediatric Investigation Plan or a decision of the EMA granting a product-specific or class waiver or deferral.
- Applicants are advised to consult their Reference Member State for general recommendations.

3. Grouping of Variations and Worksharing

- MAHs can submit one or several extensions together with other variations for the same medicinal product into one application provided that the variations concerned fall within one of the cases listed in Annex III of Regulation (EC) No 1234/2008 or when this grouping has been agreed with the Reference Member State.
- Due to the fact that the type of variation as well the timetable of the grouped variation is dependent on the “highest” type of the single changes, a grouped variation including at least one extension will be assessed as an extension application.
- Extension applications are excluded from the scope of worksharing procedures.

4. Extension applications according to the legal basis

- **A complete application according to Art. 8.3 of Dir. 2001/83/EC:**

1) When the extension is a change to a product which was granted a marketing authorisation, referring to a **complete** dossier (e.g. new strength, pharmaceutical form...).

Example 1:

**A 5mg
MAH X**

Extension

**A' 10mg
MAH X**

A is a complete dossier
A' is an extension of A (change to the originator Product A = different strength). The application for A' is considered as to be based on a complete dossier, even if the application contains references to parts of the dossier for A instead of a re-submission of those data.

- **An application according to Art. 10c of Dir. 2001/83/EC (informed consent application)**

When the extension is a change to a product which was granted a marketing authorisation according to Art. 10c.

Example 2:

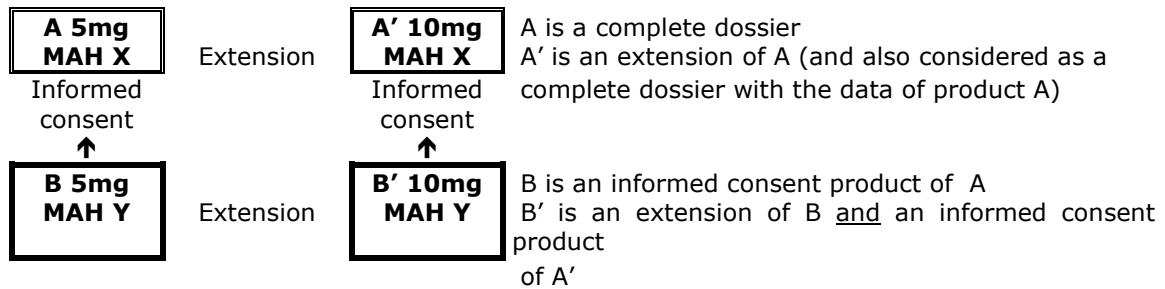

- **An application according to Art. 10a of Dir. 2001/83/EC (bibliographical application)**

When the extension is a change to a product which was granted a marketing authorisation according to Art. 10a.

Example 3:

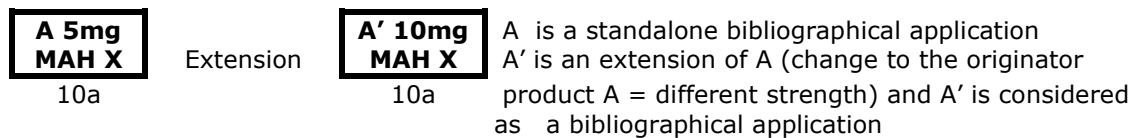

- **An application in accordance to Art. 10.1 of Dir. 2001/83/EC (generic application)**

When the extension is a change to a generic product as defined in article 10(2)(b).

Example 4:

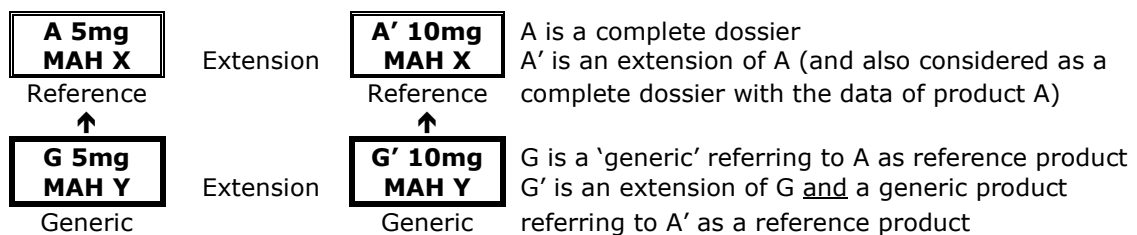

- **An application in accordance to Art. 10.3 of Dir. 2001/83/EC (hybrid application)**

When the extension is a change to a product referring to a reference medicinal product (e.g. new strength, pharmaceutical form...)

Example 5:

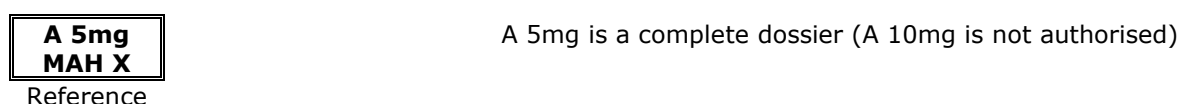

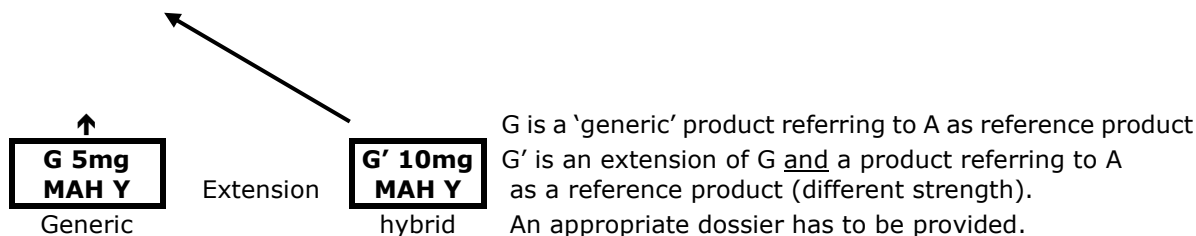

- **An application according to Art. 10b of Dir. 2001/83/EC (new fixed combination)**

When the extension is a change to a product which was granted a marketing authorisation according to Art. 10b.

Example 6:

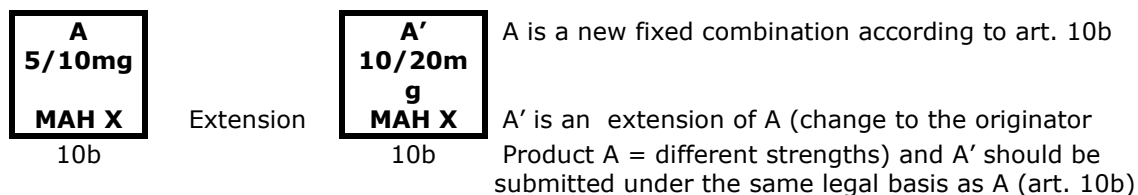

5. Specific situations

In practice, three different situations could be envisaged depending on the procedure that was used for granting a marketing authorisation to the originator product.

5.1. Situations where the originator product was granted marketing authorisations through mutual recognition/decentralised procedures

Regulation (EC) No 1234/2008 is applicable to changes to existing marketing authorisations of medicinal products which have been granted a marketing authorisation to a marketing authorisation holder through a national or a European procedure.

When fundamental changes require a new application, pursuant to Annex I of this Regulation, the mutual recognition or decentralised procedure must be used, as foreseen in Article 28 to 39 of Directive 2001/83/EC. In other terms, after one Member State has granted a marketing authorisation for an extension of a marketing authorisation granted through mutual recognition/decentralised procedure, any submission of a national application for the same extension should be considered as invalid.

Note: the Member State chosen to act as Reference Member State for MRP/DCP should remain the same unless there is a good rationale for the applicant to change.

Submission of an extension application nationally in the particular Concerned Member State (CMS) in an existing marketing authorisation of medicinal products granted through MRP/DCP is not possible. A line extension to a MRP/DCP product can only be submitted nationally in the RMS. A submission in a CMS has to follow a European procedure (MRP following authorisation of the line extension in the RMS or DCP with the RMS of the initial procedure).

5.2. Situations where the originator product was granted marketing authorisations through national procedures

Extensions of a national marketing authorisation granted in a Member State can be submitted through mutual recognition or decentralised procedures in order to obtain new authorisations in other Member

States. Therefore, for situations where the originator product was granted marketing authorisations through independent national procedures only, national and mutual recognition/decentralised procedures are acceptable on a voluntary basis of the applicant.

To allow more flexibility, the Member States reached an agreement that parallel national and mutual recognition/decentralised procedures are acceptable for the same product and that parallel mutual recognition/decentralised procedures are also acceptable. This is also applicable if the application is submitted as a stand-alone application instead of as an extension, e.g. if the originator product is not harmonised across the Member States.

Two options are possible for the applicant, national procedures (option 1) or a mutual recognition/decentralised procedure (option 2).

Option 1: national procedures

The originator product was granted marketing authorisations through independent national procedures only. The applicant wishes to apply for an extension application through national procedures.

Option 2: mutual recognition or decentralised procedure

The originator product was granted marketing authorisations through independent national procedures only. The applicant was granted/applied for a marketing authorisation for an extension in the Reference Member State and wishes to use a mutual recognition/decentralised procedure of the first authorisation in another Concerned Member States. In accordance with the Commission communication 98/C229: "prior to any mutual recognition/decentralised procedure for extensions, the applicant will have to harmonise the already approved national SmPC, PL and labelling (product information) in order to support his applications in all the Concerned Member States with the same dossier".

❶ Three different scenarios are acceptable to harmonise the product information of the nationally approved originator product:

- **either by national variation procedures:** the applicant should indicate that the purpose of the variation is harmonisation of the SmPC, PL and labelling prior to a mutual recognition/decentralised procedure for an extension and should provide relevant information on the licensed status in other Member States. The applicant should also testify that the same relevant information was (i) included in the previous dossier submitted, (ii) updated subsequently, in all CMSs involved in the procedure. The applicant is responsible for any necessary co-ordination with the national authorities during the national variation phase. When the relevant parts of the dossiers of the originator product (including product information) are the same in all concerned Member States, then the mutual recognition/decentralised procedure of the first authorisation granted in the RMS can start for the extension.

Example 1: Originator product A, Marketing Holder (MAH) X, 3 independent national MAs in 3 different Member States with 3 different dossiers D and 3 different product information (PI). National variations are submitted in the Member States in order to harmonise the dossiers and the product information.

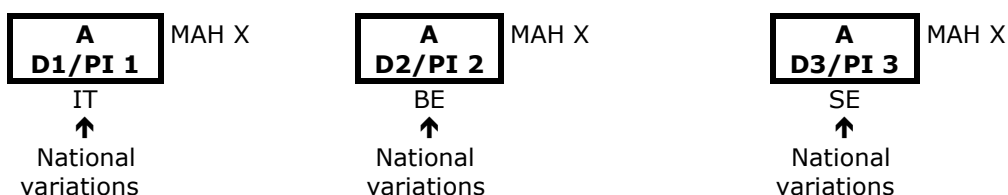

Where the relevant parts of the dossiers D of product A including product information are the same, then the mutual recognition or the decentralised procedure of the first authorisation granted in the RMS can start for the extension (A') of product A.

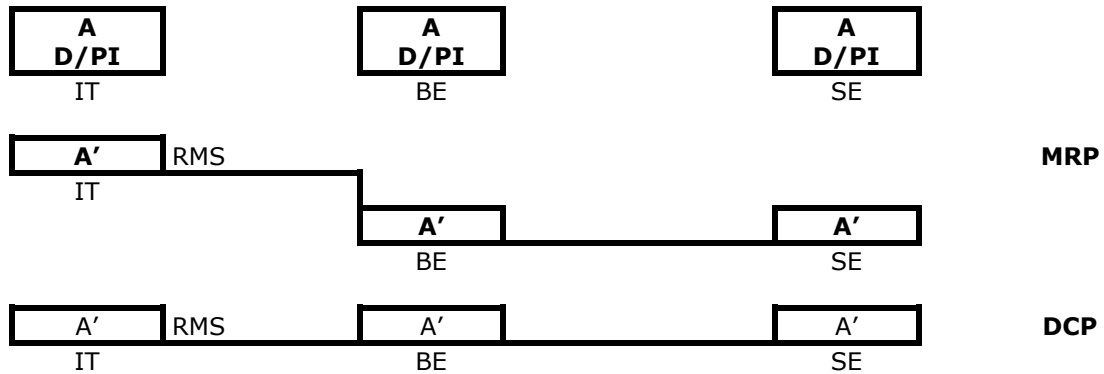

Note: in that scenario, the originator product A remains national.

Line Extension A' is granted authorisation through a mutual recognition/decentralised procedure. Any subsequent variations of A' are assessed through mutual recognition variation procedures according to Commission Regulation (EC) No 1234/2008.

However, as soon as line extension A' is granted a marketing authorisation, it is strongly recommended that harmonisation between marketing authorisations of originator product (A) and extension (A') is maintained; therefore it is recommended that subsequent variations are submitted via worksharing procedure.

- **or by a worksharing (WS) variation application:**

MAHs are encouraged to make use of the WS procedure in case of harmonisation of different products nationally approved, stand alone, of the same MAH.

This WS application should be submitted as a single type II variation under the scope C.I.4. of the classification guideline of the variation Commission regulation (EC) 1234/2008.

This WS application should fulfil all the conditions detailed in the CMDh Q/A document – List for the submission of variations according to Commission regulation (EC) 1234/2008 (Q/A 4.21) (<http://www.hma.eu/20.html>)

- **or by referral under Article 30 of Directive 2001/83/EC:**

Example 2: Originator product A, Marketing Holder (MAH) X, 3 independent national MA in 3 different Member States with 3 different dossiers D and 3 different product information. A referral under Article 30 of Directive 2001/83/EC is made on a voluntary basis by the applicant in order to harmonise the originator product.

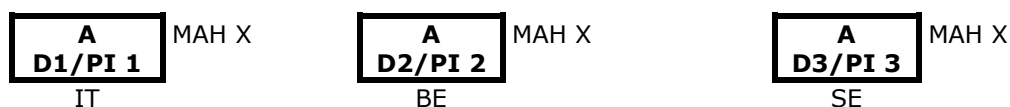

At the end of the referral procedure, dossiers D of product A are the same including the same product information, then the mutual recognition or decentralised procedure of the first authorisation granted in the RMS can start for the extension of product A (A').

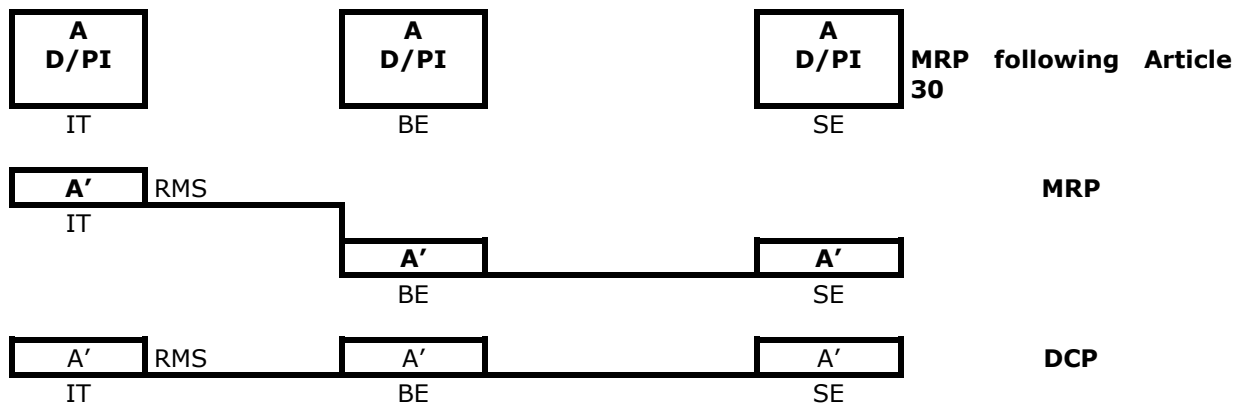

Note: in that scenario, for the originator product A as well as the extension A', any subsequent variations of A' are assessed through mutual recognition variation procedures according to Regulation (EC) No 1234/2008.

⊗ Another scenario: submission of a complete application

When the MAH of the originator product is in possession of all the information required (complete dossier), an alternative could be to complete the dossier of the extension application with data previously submitted in order to apply for a complete application in accordance with Article 8.3 of Directive 2001/83/EC instead. The procedure described in Articles 28 to 39 of Directive 2001/83/EC could then be used.

5.3. Situations where the originator product was granted marketing authorisations through a mixture of national and mutual recognition/decentralised procedures

For extensions of originator products authorised through a mixture of national and mutual recognition/decentralised procedures depending on the Member States:

- The mutual recognition or the decentralised procedure has to be followed for extensions of originator products authorised through the mutual recognition or the decentralised procedure;
- National, mutual recognition or decentralised procedures are acceptable for extensions of products authorised nationally, meaning that parallel procedures (national and mutual recognition/decentralised procedure) are acceptable in that particular case. This is also applicable if the application is submitted as a stand-alone application instead of as an extension, e.g. if the originator product is not harmonised across the Member States.