



GAPGUARD™

FIRE DOOR ACCESSORIES





GAPGUARD™ INDEX:

	Page
Cylindrical Hardware Prep Filler	GAP13
End Caps	GAP16
Fire Door Bottom Gap Solution.....	GAP9-GAP10
Fire Door Head and Jamb Gap Solution	GAP5
Fire Door Head and Jamb Gap Solution for Narrow Soffit.....	GAP6
Fire Door Top Gap Solution	GAP7
Flush Bolt Hardware Prep Filler	GAP11
GAPGUARD™ 90 Minute Strike Shims	GAP15
GAPGUARD™ 90 Minute Thru-Bolts.....	GAP15
GAPGUARD™ FIRE CAULK	GAP14
GAP90-ME Meeting Edge Gap Solution	GAP8
Hardware Prep Fillers.....	GAP14
Mortise Hardware Prep Filler	GAP12
Steel Hinge Shims	GAP16

NUMERICAL INDEX:

FDTB	GAP15	GAP90NW™	GAP6	9225.....	GAP15
GAPGUARD™		GAP90W™	GAP5	9275.....	GAP15
FIRE CAULK	GAP14	HP90	GAP14	9590.....	GAP9
GAP90™	GAP5	HP90-CYL	GAP13	9595.....	GAP10
GAP90DKB™	GAP5	HP90-FB	GAP11	9990.....	GAP7
GAP90-ME.....	GAP8	HP90-MORT.....	GAP12	9945EC.....	GAP16
GAP90N™.....	GAP6	HS-1.....	GAP16	9945NEC.....	GAP16
GAP90NDKB™.....	GAP6	5075.....	GAP5-GAP6		

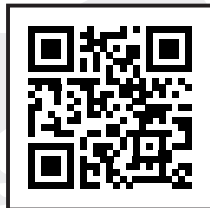

For the complete list of GapGuard™ Fire Door Accessories, the most up-to-date product information and installation instructions, scan the QR code or **visit ngp.com**.

RATINGS AND LEED

RATING SYMBOLS LEGEND



POSITIVE PRESSURE - CERTIFIED by UL to ANSI/UL10C; complies with IBC, NFPA 80 and NFPA 252 for application to Hollow Metal fire doors rated up to 3 hrs., and Wood fire doors rated up to 90 minutes (some ratings vary as noted).



CERTIFIED by UL to CAN/ULC-S104 and ANSI/UL10B, complies with NFPA 80 and NFPA 252 for application to Hollow Metal fire doors rated up to 3 Hrs., and Wood fire doors rated up to 90 minutes (some ratings vary as noted).



SMOKE & DRAFT CONTROL GASKETING, Certified by UL to ANSI/UL10C and ANSI/UL1784 Category 'H'; complies with IBC and NFPA 105 for use on 'S' labeled Positive Pressure Hollow Metal fire doors rated up to 3 hours, and Wood fire doors rated up to 90 minutes (some ratings vary as noted).



ACOUSTICAL TESTED to ASTM E90 Standard Test Method for Laboratory Measurement of Airborne Sound Transmission Loss of Building Partitions and Elements, and ASTM E2235 Standard Test Method for Determination of Decay Rates for use in Sound Insulation Test Methods. Refer to information on pages G4 and G5 of our full catalog for test result data.



AIR INFILTRATION TESTED to ASTM E283, Standard Test Method for Determining Rate of Air Leakage Through Exterior Windows, Curtain Walls, and Doors.



ANSI/BHMA CERTIFIED Certified gasketing complies with American National Standard for Door Gasketing and Edge Seal Systems ANSI/BHMA A156.22, and is listed in the BHMA Certified Products Directory.



Online product listings: ul.com/database



LEED GREEN BUILDING

The LEED (Leadership in Energy and Environmental Design) Green Building Rating System® is a national standard for developing high-performance, sustainable buildings developed by the U. S. Green Building Council.

Our current LEED letter containing LEED qualification information for all our products is available at ngp.com

Environmental Product Declarations (EPD) prepared and certified by an Independent Laboratory based on Life Cycle Assessments (LCA) of our products may be viewed on our website, ngp.com

Health Product Declarations (HPD) may be viewed on our website, ngp.com

National Guard Products sustainability report may be viewed on our website, ngp.com/report/

Contact us regarding our end of use product recycling program.



GAPGUARD™

FIRE DOOR ACCESSORIES

LIFE-SAVING MEET COST-SAVING

NGP's UL Certified 90-minute Fire Door Accessories will help you avoid the cost, labor and disruption of replacing existing doors and/or structures to achieve compliance. Whether it's an excessive gap along the perimeter of the door or a hardware revision that jeopardizes the integrity of the door itself, GapGuard™ Fire Door Accessories has a solution to get you back into compliance with ease.



Certified and stamped
for use in the US
and Canada



Eliminate the cost and
downtime of replacing existing
doors and/or structures.



Simple to install, non-handed
and in-field modifiable to
accommodate existing hardware.



Provides options that allow for
concealed installation. See the
door, not the hardware.

FIRE DOOR COMPLIANCE MADE EASY!

...AND SMARTER, MORE VERSATILE, LESS VISIBLE, MORE
COST-EFFECTIVE, SIMPLER TO INSTALL AND ORDER.

IT IS ALL OF THE THINGS!

GapGuard™ Fire Door Accessories provide you a one-stop, get your facility BACK INTO compliance, solution. Whether you have Excessive Gaps at the Head, Jamb, Meeting Edge and/or Bottom — or want to modify the hardware on an existing door while retaining compliance, we've got a solution to fit your needs.

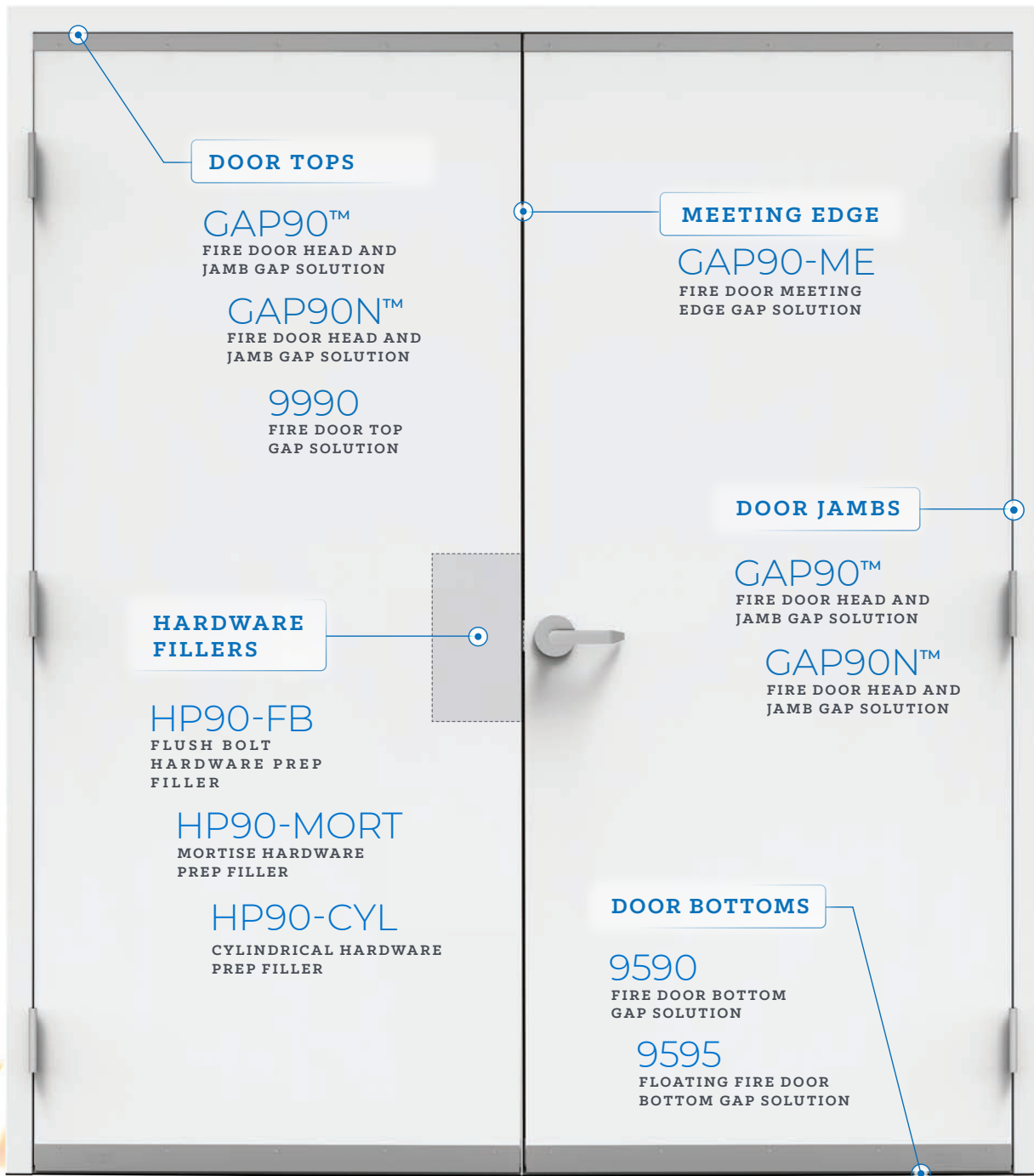

GAP90™

FIRE DOOR HEAD AND JAMB GAP SOLUTION



UL CERTIFIED FOR USE IN
THE US AND CANADA

UL Certified Solution for Fire Doors with Excessive
Clearance Between Door and Frame Over $\frac{1}{8}$ ", up to $\frac{3}{8}$ ".

INSTALLED
VIEW

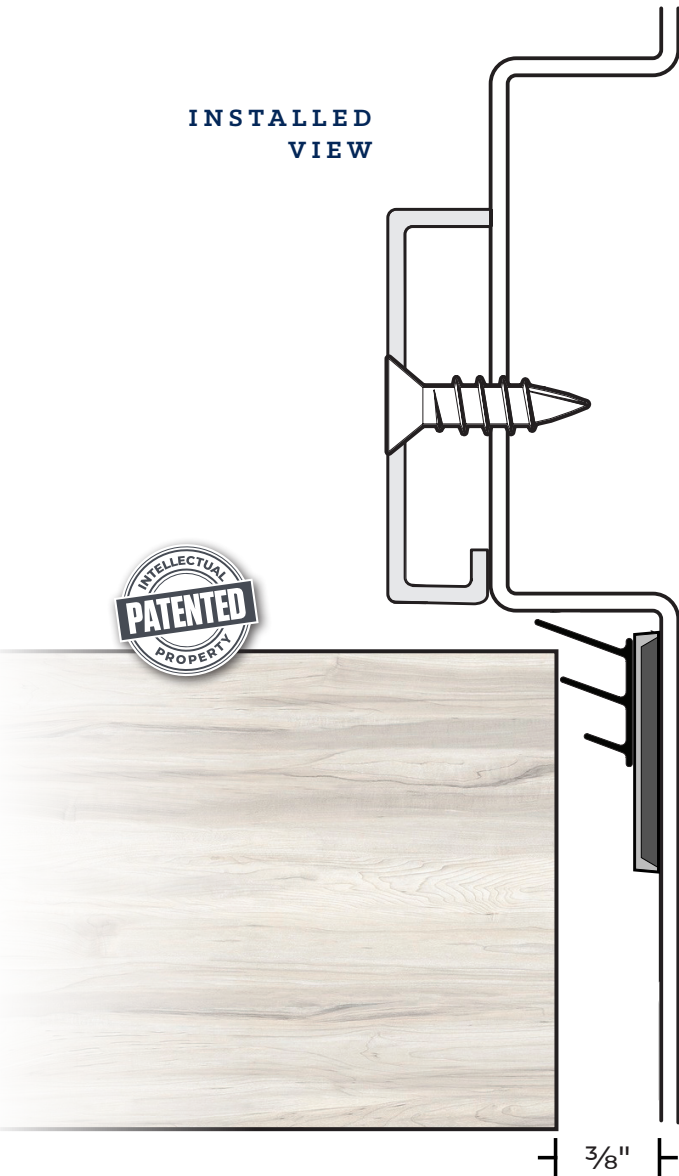

PRODUCT CONSISTS OF:

9945

Steel Stop Extender

- ◆ 16-Gauge, Gray Primer Finish
- ◆ Furnished with #10 X 1" TEK SMS
- ◆ Embossed with **UL Mark**
- ◆ Patented: US Patent 9,273,510 B2

5075

Self-Adhesive Silicone Seal

5075C CHARCOAL

5075CL CLEAR

9400

NGP-Edge® Intumescent
Seal with PVC Cover

9400GR GRAY

9400C CHARCOAL



POSITIVE PRESSURE TESTED
MISCELLANEOUS FIRE DOOR
ACCESSORY

90-Minute Rated UL Certified Miscellaneous Fire Door Accessory
on UL10B and UL10C Wood or Hollow Metal Fire Doors.

An NGP Strike Shim 9275 or 9225 may also be Required for
Proper Latchbolt Engagement.

Doors with Parallel Arm Closers — Use 9990 Fire Door Top
Gap Solution.

GAP90™ INCLUDES 9945, 9400GR, 5075CL

GAP90DKB™ INCLUDES 9945, 9400C, 5075C

Available in 36", 48", 84" and 96" Lengths

GAP90N™

FIRE DOOR HEAD AND JAMB GAP SOLUTION FOR NARROW SOFFIT



UL CERTIFIED FOR USE IN THE US AND CANADA

UL Certified Solution for Fire Doors with Excessive Clearance Between Door and Frame Over $\frac{1}{8}$ ", up to $\frac{3}{8}$ " and a Soffit Measuring $\frac{1}{2}$ " to $1\frac{3}{8}$ ".

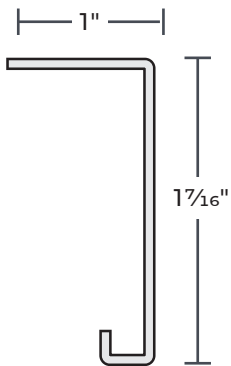

PRODUCT CONSISTS OF:

9945N

Steel Stop Extender

- ▶ 16-Gauge, Gray Primer Finish
- ▶ Furnished with #10 X 1" TEK SMS
- ▶ Embossed with **UL Mark**
- ▶ Patented: US Patent 9,273,510 B2

5075

Self-Adhesive Silicone Seal

5075C CHARCOAL

5075CL CLEAR

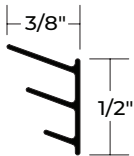

9400

NGP-Edge® Intumescent Seal with PVC Cover

9400GR GRAY

9400C CHARCOAL

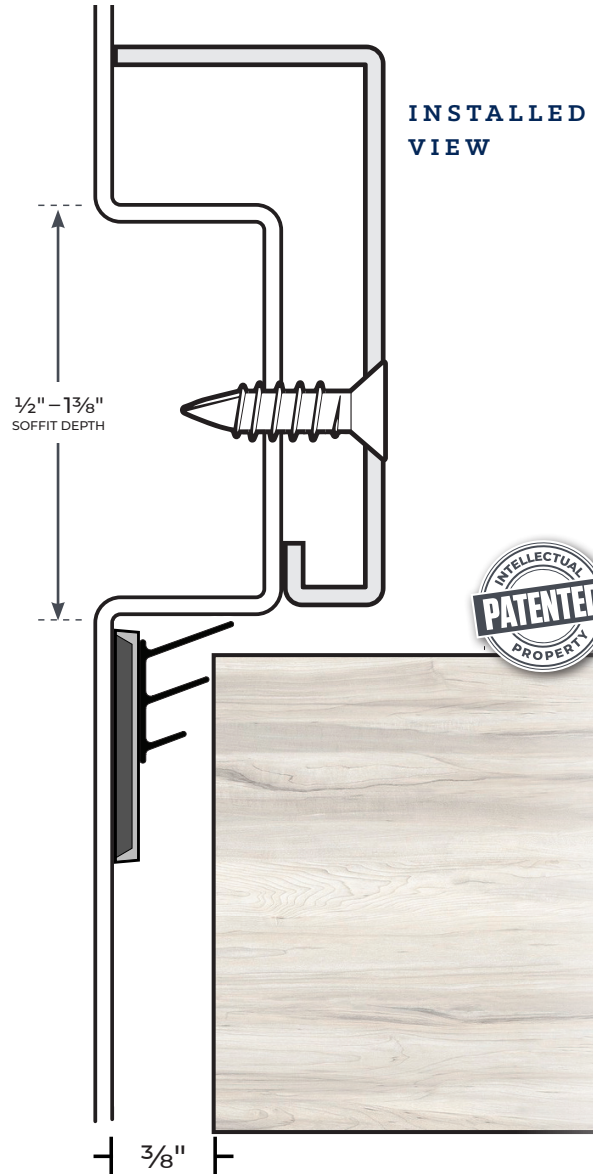
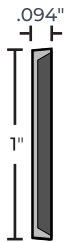

POSITIVE PRESSURE TESTED
MISCELLANEOUS FIRE DOOR
ACCESSORY

90-Minute Rated UL Certified Miscellaneous Fire Door Accessory on UL10B and UL10C Wood or Hollow Metal Fire Doors.

An NGP Strike Shim 9275 or 9225 may also be Required for Proper Latchbolt Engagement.

Doors with Parallel Arm Closers — Use 9990 Fire Door Top Gap Solution.

GAP90N™ INCLUDES 9945N, 9400GR, 5075CL

GAP90NDKB™ INCLUDES 9945N, 9400C, 5075C

Available in 36", 48", 84" and 96" Lengths

9990

FIRE DOOR TOP GAP SOLUTION



UL CERTIFIED FOR USE IN
THE US AND CANADA

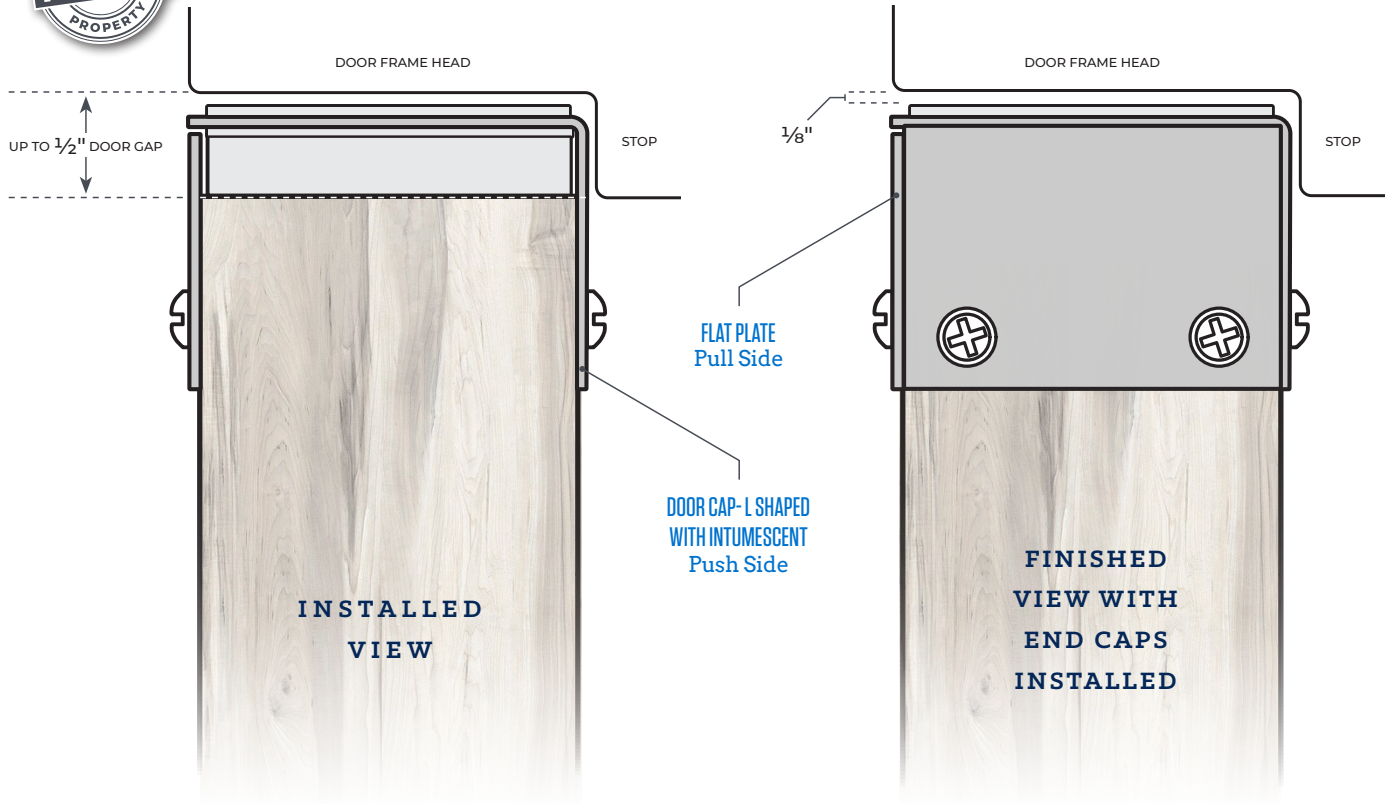

PRODUCT INFORMATION

UL Certified for Door Top Gaps — Measuring up to 1/2".

- ▶ 90-Minute Rated — for Use on UL10B and UL10C Wood or Hollow Metal Fire Doors
- ▶ Recommended for Doors with Parallel Arm Closers
- ▶ Available in 36" and 48" Lengths
- ▶ Brushed Stainless Steel
- ▶ Non-Handed
- ▶ Patented: US Patent US 11,261,653 B2

PRODUCT CONSISTS OF:

- + #304 Brushed Stainless Steel Flat Plate - Pull Side
- + #304 Brushed Stainless Steel Intumescent Cap — Push Side
- + #304 Brushed Stainless Steel End Caps
- + #6 x 3/4" Stainless Steel SMS Furnished



POSITIVE PRESSURE TESTED
MISCELLANEOUS FIRE DOOR
ACCESSORY

GAP90-ME

MEETING EDGE GAP SOLUTION



UL CERTIFIED FOR USE IN
THE US AND CANADA

**UL Certified Solution for Fire Doors
with Excessive Clearance Between
the Meeting Edges of a Pair of Doors,
up to $\frac{3}{8}$ ".**

- ▶ Application Certified on both Hollow Metal and Wood Fire-Rated Doors, up to 90-Minute
- ▶ Non-Handed
- ▶ Certified for use on Doors with Surface/ Concealed Vertical Rod Exit Devices or Manual/Automatic Flush Bolts (see *Installation Instructions*)
- ▶ Can be Installed with the Door on the Hinges
- ▶ Can be Field-Modified to Match-Fit Varying Width Gap Along Height of the Door (see *installation instructions*)
- ▶ Patented: US Patent US 11,885,175 B2

PRODUCT CONSISTS OF:

- + Formed Metal Edge, 20-Gauge Steel, Embossed With UL Mark
- + Powder Coated, Primer Gray
- + Hardware Pack
 - #10 x $\frac{3}{4}$ " FHPH SS TEK
 - #10 x 2 $\frac{1}{2}$ " FHPH SS SMS
- + GapGuard™ Fire Caulk (see *Installation Instructions*)



POSITIVE PRESSURE TESTED
MISCELLANEOUS FIRE DOOR
ACCESSORY



SPECIAL NOTES:

- 90-Minute Rated UL Certified Miscellaneous Fire Door Accessory on UL10B and UL10C Wood or Hollow Metal Fire Doors.
- An NGP Strike Shim 9275 or 9225 may also be Required for Proper Latchbolt Engagement.
- Certified for On-site Modifications Around Strike Location.
- If Fire Pins are used, it is Recommended to Apply Metal Edge to Door with Fire Pin Receiver, Ensuring Receiver is Flush with Metal Edge.
- To Retain UL Certification, the Gap90-ME must be Installed using GapGuard™ Fire Caulk.

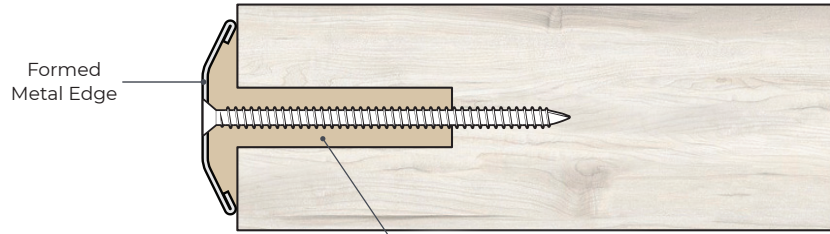

Formed
Metal Edge

$\frac{1}{2}$ " x $1\frac{1}{2}$ " Cylindrical
Anchoring Bore Filled With
Gapguard™ Fire Caulk
(wood door application only)

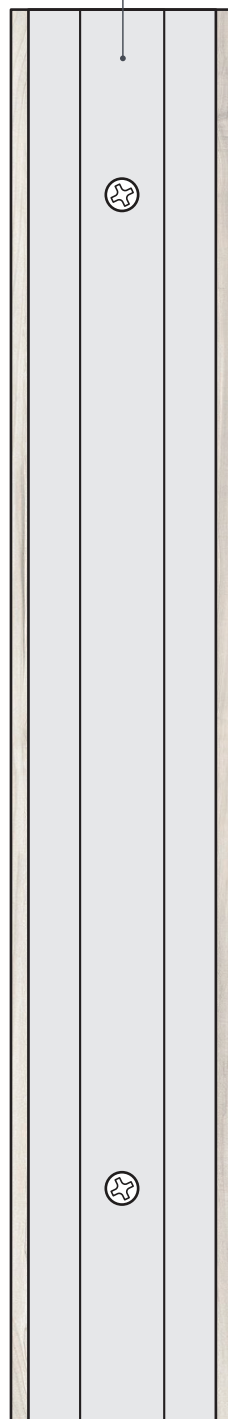

Formed
Metal Edge

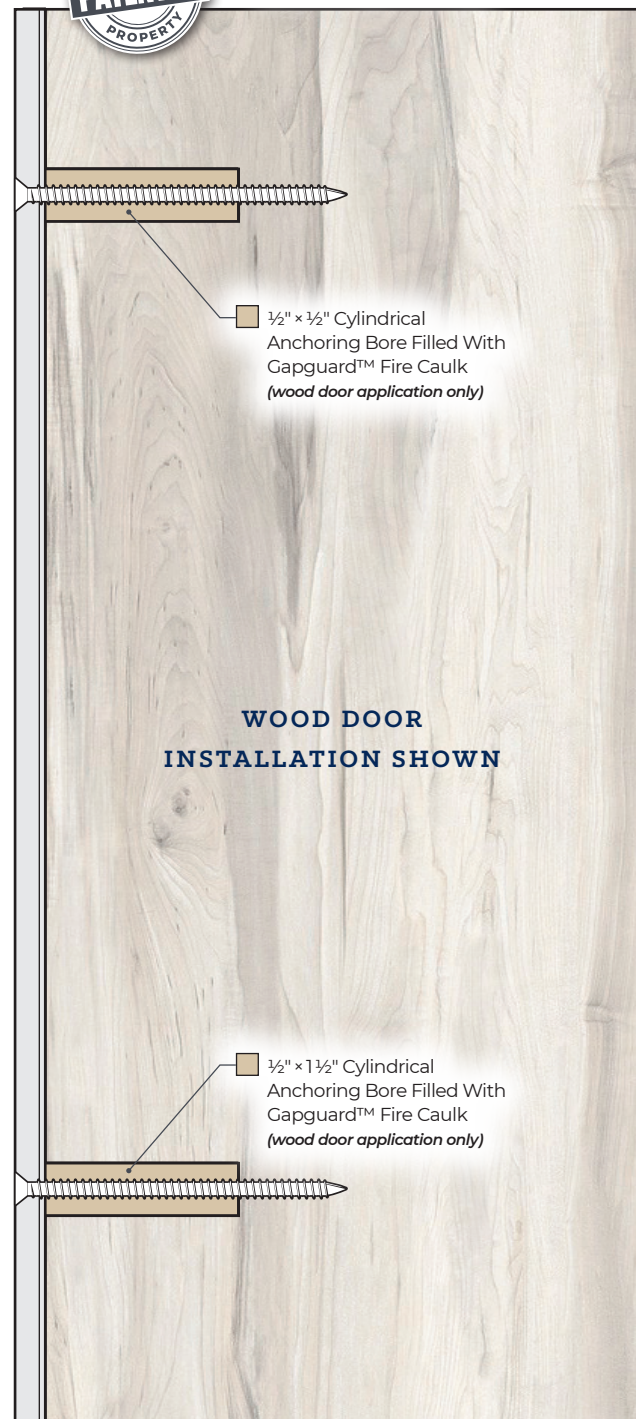

$\frac{1}{2}$ " x $\frac{1}{2}$ " Cylindrical
Anchoring Bore Filled With
Gapguard™ Fire Caulk
(wood door application only)

**WOOD DOOR
INSTALLATION SHOWN**

$\frac{1}{2}$ " x $1\frac{1}{2}$ " Cylindrical
Anchoring Bore Filled With
Gapguard™ Fire Caulk
(wood door application only)

9590

DOOR BOTTOM GAP SOLUTION



UL CERTIFIED FOR USE IN
THE US AND CANADA

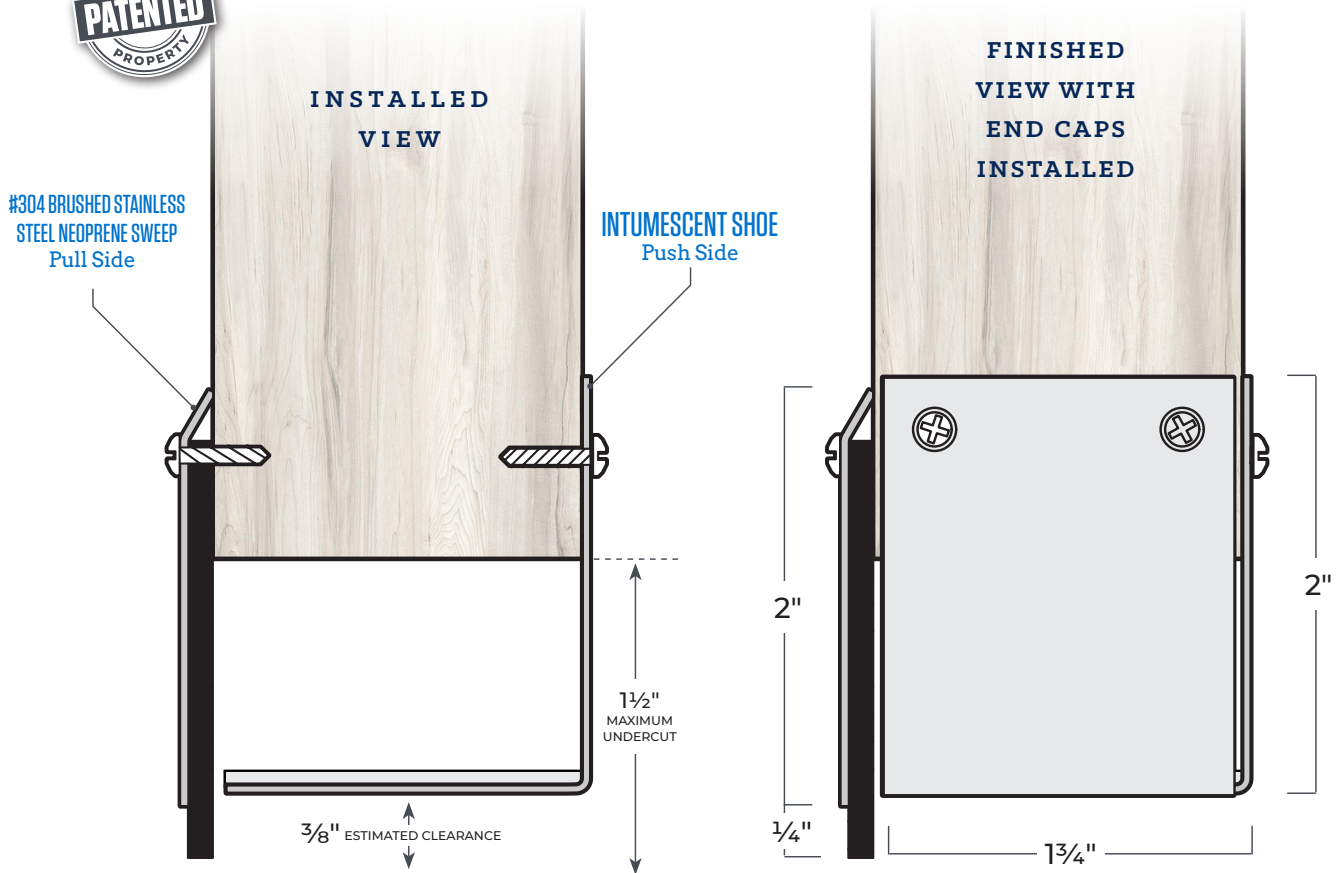

PRODUCT INFORMATION

UL Certified for Door Bottom Gaps — Measuring up to 1 1/2".

- Restricts the Passage of Smoke
- 90-Minute Rated — for Use on UL10B and UL10C Wood or Hollow Metal Fire Doors
- Available in 36" and 48" Lengths
- Non-Handed
- Patented: US Patent US 11,873,679 B2

PRODUCT CONSISTS OF:

- + #304 Brushed Stainless Steel Neoprene Sweep — Pull Side
 - + #304 Brushed Stainless Steel Intumescent Shoe — Push Side
 - + #304 Brushed Stainless Steel End Caps
 - + #6 × 3/4" Stainless Steel SMS Furnished
- Brushed stainless steel
Neoprene is black*



POSITIVE PRESSURE TESTED
MISCELLANEOUS FIRE DOOR
ACCESSORY

9595DKB

DOOR BOTTOM GAP SOLUTION



UL CERTIFIED FOR USE IN
THE US AND CANADA

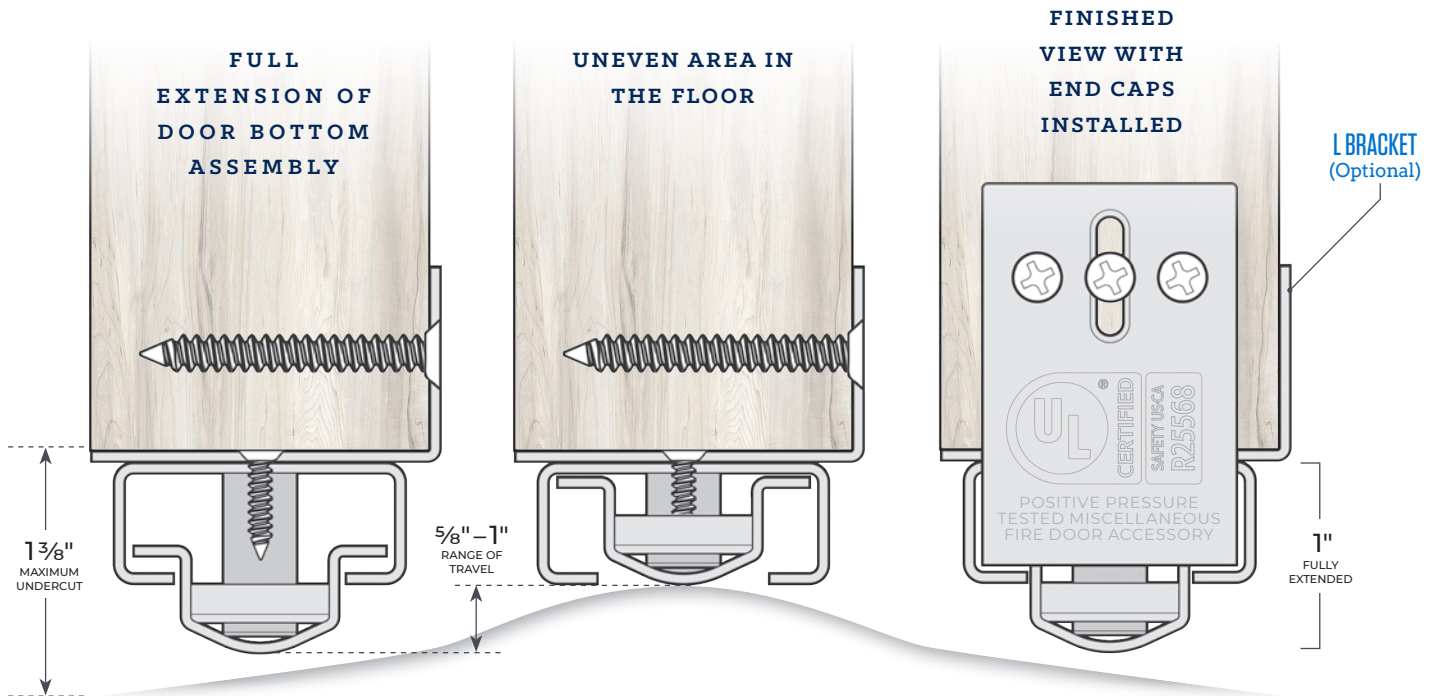

PRODUCT INFORMATION



UL Certified Solution for Fire Doors With Excessive Clearance Between the Bottom of the Door and Finished Floor, up to 1 3/8".

- ▶ Application Certified on both Hollow Metal and Wood Fire-Rated Doors, up to 90-Minutes
- ▶ Non-Handed
- ▶ L-bracket Allows Installation while Door Remains on Hinges
- ▶ Field Trim to Fit: up to 1 1/2" per side, 3" Total
- ▶ Designed to Travel Over Uneven Floors, with a Range of 3/8"
- ▶ May be Fastened to the Underside of the Door's Bottom Rail to Minimize Visibility.
- ▶ End Caps Set Height Position and Provide a Finished Look
- ▶ Sizes: 36", 42" and 48"
- ▶ Patented: US Patent US 11,761,262 B2

PRODUCT CONSISTS OF:

- + L-Bracket, 16-Gauge Steel, Embossed with UL Mark
- + Door Bottom Assembly, 18-Gauge Steel
- + End Caps, 18-Gauge Steel, Embossed With UL Mark
- + Hardware Pack
 - #10 x 1 1/2" PHPH SS SMS (DKB)
 - #8-32 x 1 3/4" PHP SS Thru-Bolt (DKB)
 - #6 x 3/8" SS TEK
 - #10 x 2" PHPH SS SMS
 - #6 x 3/4" FHPH SS SMS (DKB)

Powder Coated, DKB



POSITIVE PRESSURE TESTED
MISCELLANEOUS FIRE DOOR
ACCESSORY

HP90-FB

FLUSH BOLT HARDWARE PREP FILLER



UL CERTIFIED FOR USE IN
THE US AND CANADA

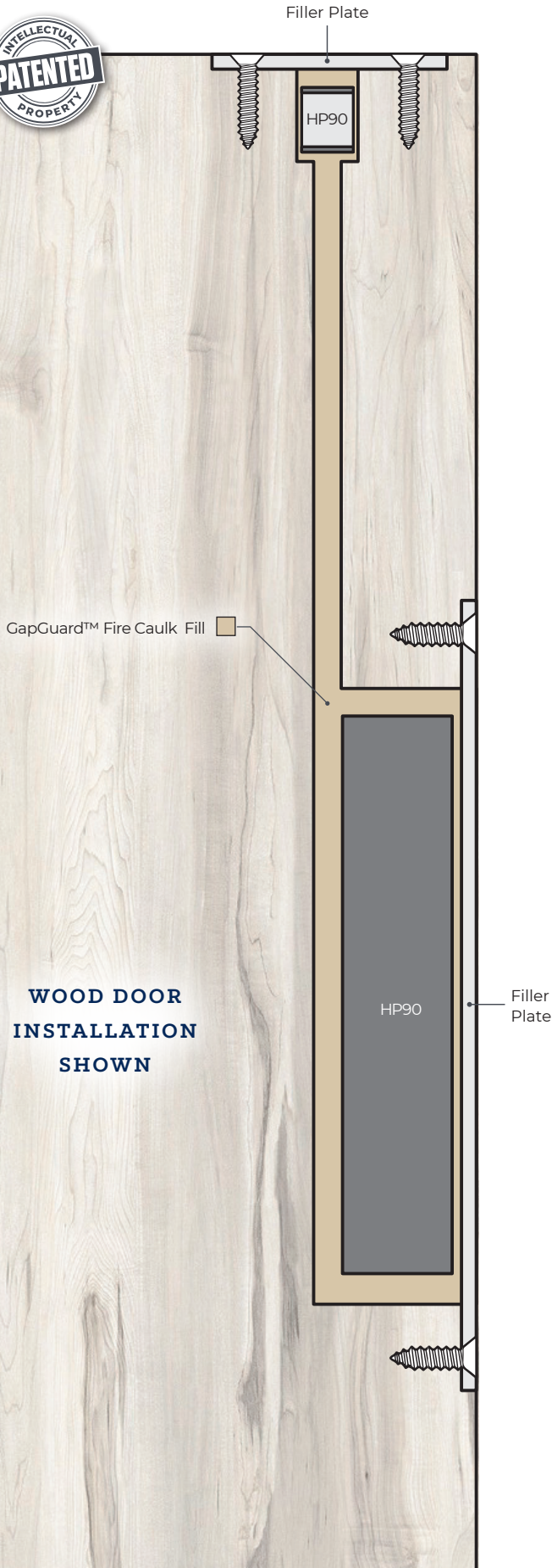

UL Certified Solution for Fire Doors When Either Removing Existing Hardware and/or Using a New Hardware Type Over Existing Hardware Prep's.

PRODUCT INFORMATION

- Application Certified On Both Hollow Metal And Wood Fire-Rated Doors Up To 90-Minutes
- Certified for Filling Manual or Automatic Flush Bolt Cavities
- Patented: US Patent US 11,959,332 B2

PRODUCT CONSISTS OF:

- + HP90 – 2" x 6" Rectangular Fire-Rated Panel
- + HP90 – 0.5 Cylindrical Fire-Rated Panel
- + Steel Filler Plates: *(Powder Coated Primer Gray, Embossed With UL Mark)*
 - HP90-FBE6750, Edge Filler Plate
 - HP90-FBE8500, Edge Filler Plate
 - HP90-FBL2000, Latch Bolt Filler Plate
 - HP90-FBL2500, Latch Bolt Filler Plate
 - HP90-FBL3875, Latch Bolt Filler Plate
 - HP90-SF2250, Strike Filler Plate
- + Hardware Pack
 - #10-32 x 1-3/4" FHPH SS machine screw
 - #8 x 3/4" FHPH SS combo screw
 - #12 x 1" FHPH SS combo screw
 - #8 x 3/4" FHPH SS SMS
 - #12 x 1" FHPH SS SMS
- + GapGuard™ Fire Caulk *(see Installation Instructions)*



POSITIVE PRESSURE TESTED
MISCELLANEOUS FIRE DOOR
ACCESSORY



SPECIAL NOTES:

- 90-Minute Rated UL Certified Miscellaneous Fire Door Accessory on UL10B and UL10C Wood or Hollow Metal Fire Doors
- To Retain UL Certification, the HP90-MORT must be Installed using GapGuard™ Fire Caulk

HP90-MORT

MORTISE HARDWARE PREP FILLER



UL CERTIFIED FOR USE IN
THE US AND CANADA



**UL Certified Solution for Fire Doors When
Either Removing Existing Hardware and/or
Using a New Hardware Type Over Existing
Hardware Prep's.**

PRODUCT INFORMATION

- ▶ Application Certified on Both Hollow Metal and Wood Fire-Rated Doors – up to 90-Minute
- ▶ Certified for Filling Mortise Lockset Cavities
- ▶ Patented: US Patent US11,959,332 B2

PRODUCT CONSISTS OF:

- + HP90 – 4" x 6" Fire-Rated Panel
- + Steel Filler Plates: *(Powder Coated Primer Gray, Embossed With UL Mark)*
 - HP90-MEF1258, Edge Filler Plate
 - HP90-SF4875, Strike Filler Plate
- + Hardware Pack
 - #10-32 x 1-3/4" FHPH SS machine screw
 - #8 x 3/4" FHPH SS combo screw
 - #12 x 1" FHPH SS combo screw
 - #8 x 3/4" FHPH SS SMS
 - #12 x 1" FHPH SS SMS
- + GapGuard™ Fire Caulk
(see Installation Instructions)



POSITIVE PRESSURE TESTED
MISCELLANEOUS FIRE DOOR
ACCESSORY



SPECIAL NOTES:

· 90-Minute Rated UL Certified
Miscellaneous Fire Door Accessory
on UL10B and UL10C Wood or Hollow
Metal Fire Doors

· To Retain UL Certification, the HP90-MORT must
be installed using GapGuard™ Fire Caulk

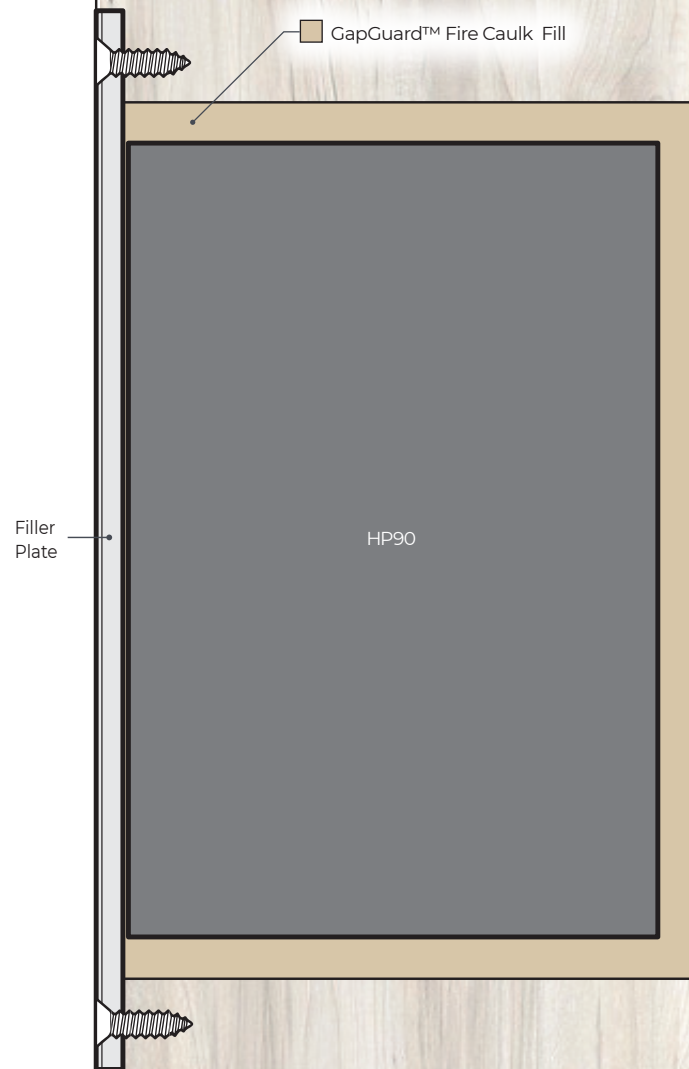

**WOOD DOOR
INSTALLATION
SHOWN**

HP90-CYL

CYLINDRICAL HARDWARE PREP FILLER



UL CERTIFIED FOR USE IN
THE US AND CANADA

**UL Certified Solution for Fire Doors When
Either Removing Existing Hardware and/or
Using a New Hardware Type Over Existing
Hardware Prep's.**

- ▶ Application Certified on both Hollow Metal and Wood Fire-Rated Doors, up to 90 Minutes
- ▶ Certified for Filling Cylindrical Lockset Cavities
- ▶ Patented: US Patent 11,959,332 B2



WOOD DOOR: INSTALLED VIEW



■ GapGuard™ Fire Caulk Fill

STEEL DOOR: INSTALLED VIEW

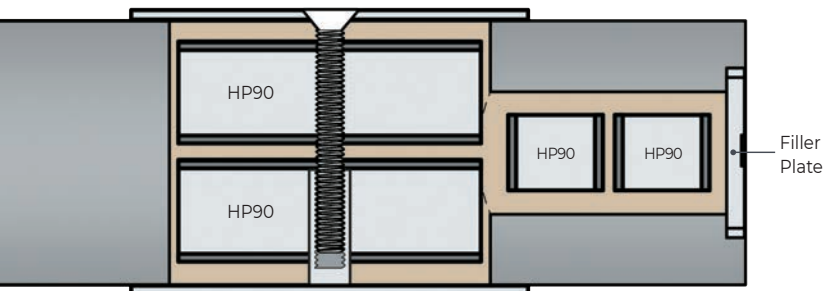

■ GapGuard™ Fire Caulk Fill

PRODUCT CONSISTS OF:

- + Fire-Rated Panels:
 - HP90 – 2.0
 - HP90 – 1.0
 - HP90 – 0.5
- + Steel Filler Plates, Powder Coated, Primer Gray, Embossed with UL Mark
 - HP90-RDCP, Filler Plate
 - HP90-CEF1000, Edge Filler Plate
 - HP90-SF2750, Strike Filler Plate
 - HP90-SF4875, Strike Filler Plate
- + Hardware Pack
 - #10-32 x 1 3/4" FHPH SS Machine Screw
 - #8 x 3/4" FHPH SS Combo Screw
 - #12 x 1" FHPH SS Combo Screw
 - #8 x 3/4" FHPH SS SMS
 - #12 x 1" FHPH SS SMS
- + GapGuard™ Fire Caulk
(see *Installation Instructions*)



POSITIVE PRESSURE TESTED
MISCELLANEOUS FIRE DOOR
ACCESSORY



SPECIAL NOTES:

- 90-Minute Rated UL Certified Miscellaneous Fire Door Accessory on UL10B and UL10C Wood or Hollow Metal Fire Doors
- To Retain UL Certification, the HP90-MORT must be Installed using GapGuard™ Fire Caulk

HP90

HARDWARE PREP FILLERS



UL CERTIFIED FOR USE IN
THE US AND CANADA

UL Certified Solution for Fire Doors When Either Removing Existing Hardware and/or Using a New Hardware Type Over Existing Hardware Prep's.

- ▶ Application Certified on both Hollow Metal and Wood Fire-Rated Doors, up to 90 Minutes
- ▶ Certified for Use in Combination With Gap Guard™ Fire Caulk to Fill Thru-Holes Between ½" Diameter and 2 ½" Diameter



PART NO.	DESCRIPTION
HP90 - 0.5	½" Diameter Hardware Prep Filler (10 Pack)
HP90 - 1.0	1" Diameter Hardware Prep Filler (10 Pack)
HP90 - 1.5	1½" Diameter Hardware Prep Filler (10 Pack)
HP90 - 2.0	2" Diameter Hardware Prep Filler (10 Pack)



POSITIVE PRESSURE TESTED
MISCELLANEOUS FIRE DOOR
ACCESSORY

GAPGUARD™ FIRE CAULK



UL CERTIFIED FOR USE IN
THE US AND CANADA

UL Certified Solution for Fire Doors and Frames to Seal Thru-Holes as well as in Combination With Other Hardware Prep Filler Solutions.

PRODUCT INFORMATION

- ▶ Application Certified on both Hollow Metal and Wood Fire-Rated Doors, up to 90-Minutes
- ▶ Can be Used to Fill up to a ½" Diameter Thru-Hole
- ▶ Fully Cured in 24 Hours
- ▶ Can be Sanded and Painted after Full Cure
- ▶ Indoor Use Only
- ▶ Shelf Life is 12 Months
- ▶ 10.3 fl. oz. Cartridge
- ▶ 10 Tubes per Box

Color: Tan



POSITIVE PRESSURE TESTED
MISCELLANEOUS FIRE DOOR
ACCESSORY

GAPGUARD™ STRIKES

90 MINUTE STRIKE SHIMS



UL Certified Miscellaneous GAPGUARD™ for Excessive Door and Frame Clearances, Measuring up to 5/16".

9275 - Fits 4 7/8" 'ASA' Strike Plate

9225 - Fits 2 3/4" 'T' Strike Plate

UL Certified Miscellaneous Fire Door Accessory for Excessive Door and Frame Clearances, Measuring Up To 5/16"

Required for Proper Latchbolt Engagement
90-Minute Rated UL10B and UL10C Wood or Hollow Metal Fire Doors

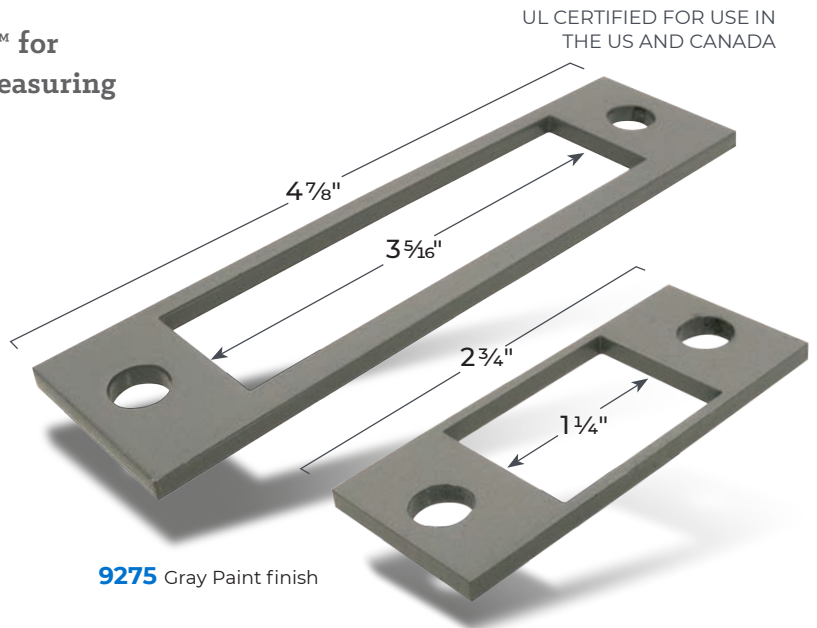

9275 Gray Paint finish

9225 Gray, Paint finish



POSITIVE PRESSURE TESTED
MISCELLANEOUS FIRE DOOR
ACCESSORY

GAPGUARD™ THRU-BOLTS

90 MINUTE THRU-BOLTS



- ▶ Fits 1 3/4" to 2" Thick Doors
- ▶ Zinc-Plated Steel Sleeve with Machine Screws
- ▶ Meets Requirements of NFPA 80 for Use on Fire Doors
- ▶ Use to Fill Holes in Wood or Steel Fire Doors to Protect Label Compliance
- ▶ Available in Boxes of Twenty

UL CERTIFIED FOR USE IN THE US AND CANADA



POSITIVE PRESSURE TESTED
MISCELLANEOUS FIRE DOOR
ACCESSORY

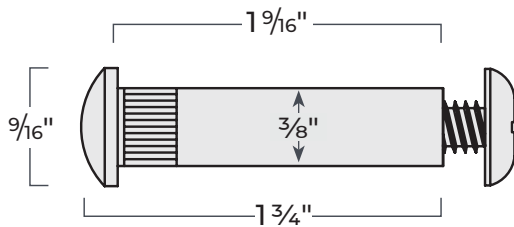

FDTB 3/8"
Thread Size 1/4-20

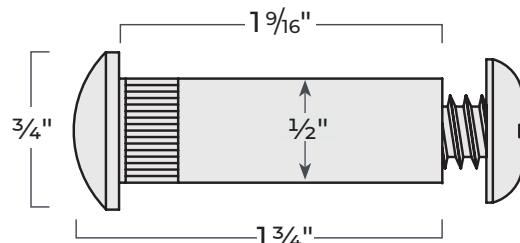

FDTB 1/2"
Thread Size 5/16-18

STEEL HINGE SHIMS



UL CERTIFIED FOR USE IN THE US AND CANADA

HS-1

- Use to Shim Hinges to Achieve Required Clearances Between Door and Frame
- Dual Purpose Shim
 - Use Full 42" Length for Continuous Hinges
 - Break-Off 3 1/2" Sections for Butt Hinges
- Steel Fire-Rated Shims
- Pressure Sensitive Adhesive Pads Included for Holding in Place During Installation
- Removable, Re-Stickable, and Stackable
- Available in Boxes of Ten

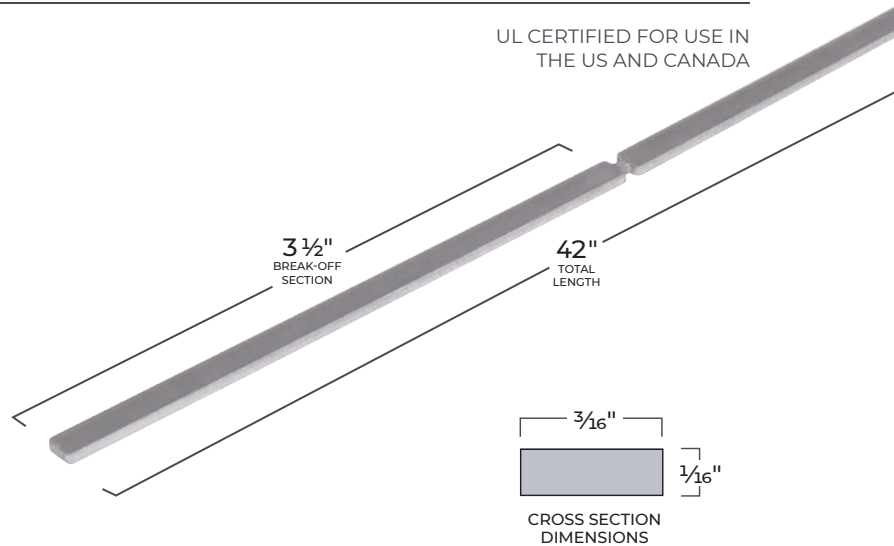

POSITIVE PRESSURE TESTED
MISCELLANEOUS FIRE DOOR
ACCESSORY

9945EC & 9945NEC

END CAPS

UL CERTIFIED FOR USE IN THE US AND CANADA

For Use on GAP90 and GAP90N Steel Stop Extender Components 9945 and 9945N.

- Use to Cap the Exposed Open End of the Steel Stop Extender When Cut at Rim Panic Strike or Other Hardware
- Sold in 10 Packs
- Sold Flat, Tabs Must be Formed Prior to Use

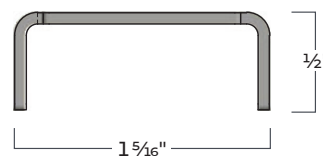

9945EC

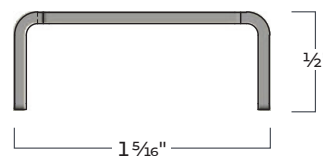

9945NEC



POSITIVE PRESSURE TESTED
MISCELLANEOUS FIRE DOOR
ACCESSORY

NOTES



A PURSUIT OF PERFECTION:

The Product Development Team continues to innovate and test new products - a constant state of improvement.

A SMALL GAP IS A BIG DEAL

UNDERSTANDING THE PROBLEM

A Fire Door "Gap" is the space between the door and the door frame head, jamb or floor. When this space exceeds tolerances (defined by NFPA 80 and enforced by The Joint Commission), it is considered "excessive". The problem with an excessive gap is that it can allow the smoke and/or fire to pass through the opening and jeopardizes the integrity of the door. An excessive gap leads to failed code inspections that will cost your organization thousands of dollars in penalties.

Most importantly, they cause a fire door to fail, putting lives at risk!

IDENTIFY "EXCESSIVE" GAPS

(As specified by NFPA 80, 2010)

AT THE DOOR HEAD, JAMB AND MEETING EDGE



DOOR HEAD



DOOR JAMB

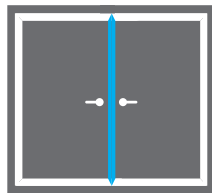

MEETING EDGE

**HOLLOW
METAL
DOORS**

$\frac{1}{8}'' \pm \frac{1}{16}''$

**FIRE-RATED
WOOD
DOORS**

UP TO $\frac{1}{8}''$

AT THE DOOR BOTTOM



DOOR BOTTOM

**WOOD &
METAL
DOORS**

$\frac{3}{4}''$



For the most up-to-date
GapGuard™ Fire Door
Accessories Catalog
scan the QR code
or visit ngp.com.



ngp.com
1-800-NGP-RUSH

FAX: (800) 255-7874
QUOTES: quotes@ngp.com
ORDERS: orders@ngp.com

NGP MEMPHIS
4985 East Raines Road
Memphis, TN 38118

CARSON CITY
3689 Arrowhead Drive
Carson City, NV 89706