



Activities for  
Students to Learn  
about Prehistoric  
Mound Builders

Deborah Buco, M.Ed.

# POVERTY POINT

E X P E D I T I O N S

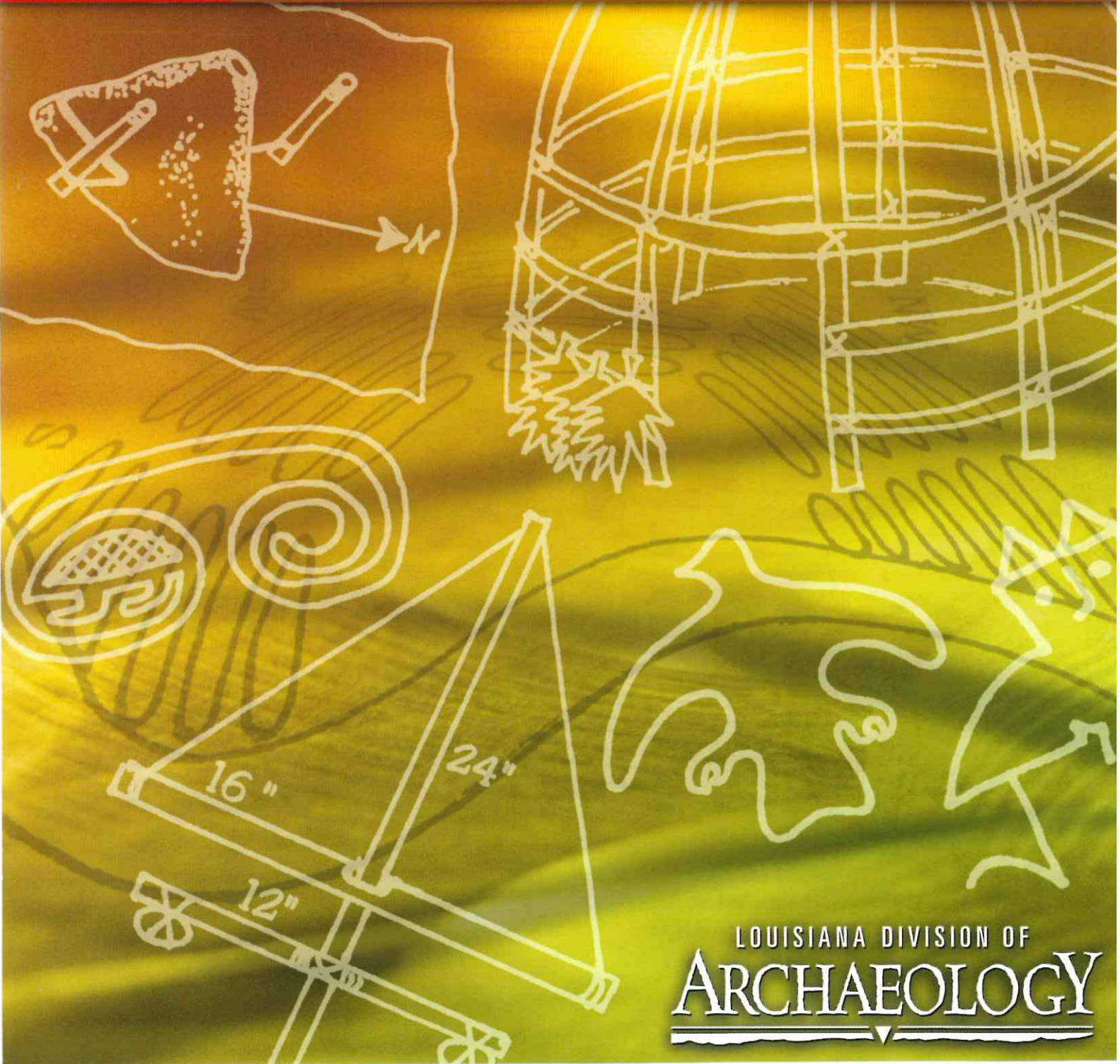

LOUISIANA DIVISION OF  
**ARCHAEOLOGY**



# Poverty Point Expeditions

Deborah Buco, M.Ed.

1999

Division of Archaeology  
Office of Cultural Development  
Department of Culture, Recreation and Tourism  
State of Louisiana

Copyright © State of Louisiana  
All rights reserved

Deborah Buco  
*Poverty Point Expeditions*  
1999  
Division of Archaeology  
State of Louisiana  
Baton Rouge

This publication is available from:  
Division of Archaeology  
P.O. Box 44247  
Baton Rouge, LA 70804  
1-225-342-8170

Text, Design, Photos, and Graphic Artwork by Deborah Buco  
Other Artwork, as noted, by Jon Gibson and Clarence H. Webb, used with permission  
Map Production Assistance by Thomas Eubanks  
Editing by Nancy Hawkins  
Cover by Zoom Design, Inc.  
Printing by Moran Printing, Inc.

This public document was published at a total cost of \$23,700.00. Four thousand (4,000) copies of this public document were published in this second printing at a cost of \$9,550.00. The total cost of all printings of this document including reprints is \$23,700.00. This document was published for the Division of Archaeology by Moran Printing, Inc., 5425 Florida Blvd., Baton Rouge, LA 70806, to make available to citizens of Louisiana information about prehistoric and historic archaeology under authorization of La. R.S. 41:1601-1614. This material was printed in accordance with standards for printing by state agencies established pursuant to R.S. 43:31. Printing of this material was purchased in accordance with the provisions of Title 43 of the Louisiana Revised Statutes.



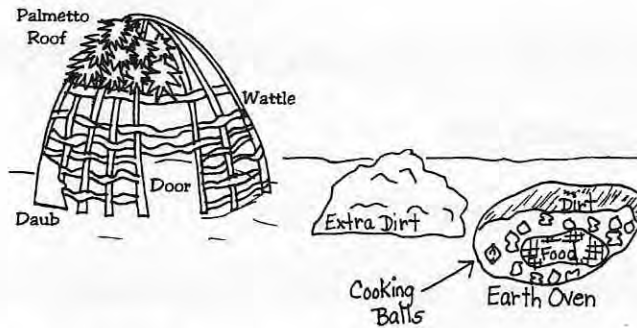

## Table of Contents

---



---

Visit the Poverty Point State Commemorative Area!	v
Acknowledgments	vii
About the Author and About the Division of Archaeology	viii
Introduction	ix

### Activities

An Overview of Poverty Point	1
Time Line of History	6
Our Poverty Point Addresses	11
Topography Training	16
Building a Mound for the Birds!	24
The Run for the Ridges	30
Home, Home on the Ridge	33
Wattle You Build Next?	40
Atlatl Antics	45
The "Do It Yourself" Atlatl	54
Poverty Point Cooking Balls	60
Cooking in an Earth Oven	64

Poverty Point Ovens: Getting the Temperature Right!	69
Prehistoric Pump Drills	80
Perplexing Poverty Point Figurines	87
Bird Gods? Fox Man? Long Tail? Too Good to Myth!	92
Artifacts All Over the Place	97

## Appendixes

Appendix A: Suggestions for Authentic Assessment	127
Appendix B: Correlation to Louisiana State Standards for Curriculum Development Grades K-4	129
Appendix C: Correlation to Louisiana State Standards for Curriculum Development Grades 5-8	137
Appendix D: Resources	143

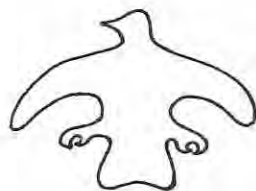
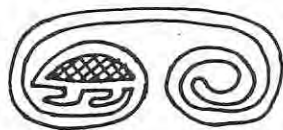

# Visit the Poverty Point State Commemorative Area!



Much of the Poverty Point site is owned by the state of Louisiana and is operated by the Office of State Parks. The Poverty Point State Commemorative Area is in West Carroll Parish, east of Monroe on LA 577. From Monroe, go east on I-20 approximately 35 miles to the Delhi exit. Travel north on LA 17 to Epps, east on LA 134, and north on LA 577.

Poverty Point State Commemorative Area has a museum with an audio-visual presentation and displays of artifacts found at the site. Picnic areas, an observation tower, restrooms, and tours are also available to visitors.

Poverty Point State Commemorative Area is open to the public 9 a.m. to 5 p.m. daily, except New Year's Day, Thanksgiving, and Christmas. Admission is \$2.00 for visitors ages 13-61; school groups are free. Call 1-888-926-5492, toll-free, for more information, or to schedule group visits. To receive a brochure about the Poverty Point State Commemorative Area, contact the Office of State Parks, P.O. Box 44426, Baton Rouge, LA 70804-4426; 1-225-342-8111 or 1-888-677-1400.





# Acknowledgments

Nancy Hawkins, the Outreach Coordinator for the Division of Archaeology, has been of invaluable assistance in developing and editing these activities. She has helped by explaining archaeological concepts, reading for clarity, and making marvelous suggestions for improving the activities.

Robert Connolly, the Station Archaeologist at the Poverty Point State Commemorative Area, is a teacher's dream come true! Dr. Connolly has answered countless questions, provided resources for activities, and given presentations to my classes. He has corresponded by e-mail with my students, answering their questions in language they could understand and providing them with an "on line" expert.

Both Ms. Hawkins and Dr. Connolly are outstanding educators who have done a marvelous job of promoting archaeological education in Louisiana. They are to be commended for their tireless efforts on behalf of the children of Louisiana.

Drawings of artifacts, graphs, and maps used in some activities were enlarged from those found in *The Poverty Point Culture* by Clarence Webb. This monograph was published in 1982 by the Department of Geography and Anthropology at Louisiana State University in Baton Rouge. Drawings from Jon L. Gibson's *Poverty Point: A Terminal Archaic Culture of the Lower Mississippi Valley* were used as well. That booklet was published by the Louisiana Department of Culture, Recreation and Tourism in 1996. All of these drawings are used with permission and many thanks. The original drawings done in pen and ink and the photographs of students were created by the author.

Help on atlatl construction was provided by Richard VanderHoek. Drawings of an atlatl and pump drill from the Poverty Point State Commemorative Area provided the inspiration for the adaptations of them included here. Staff at the Poverty Point Commemorative Area also demonstrated and explained earth oven cooking and throwing a spear with an atlatl. Staff at the Marksville State Commemorative Area are to be credited with demonstrating palmetto hut construction.

Thanks to the students at Buchanan Elementary, G.W. Carver Primary, and Gonzales Middle School, some of whom are pictured in the activities. Their enthusiasm for learning about Poverty Point led to the development of these activities.

The Ascension Parish School Board has been gracious in granting me a semester's leave in order to complete this project. I appreciate their understanding and cooperation because this could never have been a weekends and evenings project.

Thanks to the Kelly G. Cook Foundation for the materials and computer equipment they provided for a multimedia HyperStudio classroom project which in turn sparked the idea for this project.

There could never be enough love and appreciation for Steve and the Buco children.

## About the Author

Deborah Buco has been teaching elementary and middle school for over 17 years. She holds a B.S. in Elementary Education, a Master's degree in Guidance and Counseling, and certification in gifted education. Deborah is currently teaching in Ascension Parish. Deborah has taught the Poverty Point unit with elementary and middle school students. Deborah and Nancy Hawkins have presented these activities at several teacher workshops and conferences, always to an enthusiastic audience.



## About the Division of Archaeology

The Division of Archaeology is a state agency that works to record and protect Louisiana's irreplaceable archaeological sites. It also promotes an understanding of these sites by providing information to the public, and especially to educators, through publications, exhibits, and classroom activities. Contact the Division of Archaeology to receive these free materials about Louisiana archaeology:

- classroom suitcase exhibit about Poverty Point or *El Nuevo Constante*, a Spanish shipwreck

- Poverty Point: A Terminal Archaic Culture of the Lower Mississippi Valley* booklet

- Indians of Louisiana*, a lower elementary picture book

- Classroom Archaeology*, a middle school activity guide

- Adventures in Classroom Archaeology*, a K-12 activity guide

- a schedule of Louisiana Archaeology Week activities

- lists of videos and books about Louisiana archaeology

- a list of regional and station archaeologists, who can provide information about sites

- summaries of laws protecting archaeological sites

The Division of Archaeology, which is a part of the Office of Cultural Development in the Department of Culture, Recreation and Tourism, can be contacted in the following ways:

Division of Archaeology

P.O. Box 44247

Baton Rouge, LA 70804

Telephone: 1-225-342-8170

E-mail: [arch@crt.state.la.us](mailto:arch@crt.state.la.us)

Internet: <http://www.crt.state.la.us/>

# Introduction

These activities were developed to help students learn about the prehistoric mound builders who constructed the massive earthworks at the Poverty Point site near Epps, Louisiana and throughout the Mississippi River delta region. This unit is designed to teach archaeological concepts and aspects of the Poverty Point Culture through "hands on" activities which integrate basic curriculum areas and higher level thinking skills. Children will use reading, language, math, science, social studies, art, drama, and physical education skills in meaningful and creative ways as they develop problem solving skills. While doing so, they will also learn about an important part of American history which occurred before Columbus "discovered" these shores.

The activities are also designed to be fun! Students get to act as archaeologists while analyzing artifacts and actual data from Poverty Point. They will make Poverty Point cooking balls for earth oven cooking just as the Poverty Point people did over 3,000 years ago and then experiment to determine if different shapes were used to regulate the amount of heat in the ovens. Students will also be given the opportunity to build pump drills and an ancient spear throwing device called an atlatl. After creating original stories and myths about Poverty Point figurines and ancient carved images, students can dramatize their stories for others. Each of the activities is interdisciplinary and focuses on multiple areas of the curriculum, as well as addressing the requirements of the Louisiana Curriculum Standards.

Enjoy this unit! Try to squeeze in as many activities as you can, but feel free to skip around if you have a limited amount of time. Some of the activities are interrelated, but they will all stand alone if necessary. Information for the teacher, student handouts, and overhead transparency masters are included with each lesson. Each lesson plan includes the following components:

**Subject Areas:** a list of curriculum areas addressed by the activity.

**Objectives:** a description of concepts or skills developed by the activity.

**Time:** the amount of time needed for the activity.

**Materials:** a list of all items needed to conduct the activity.

**Must Know Info:** background information on the activity's content area.

**Procedures:** instructions for conducting the activity with students.

After completing each activity, evaluation of student performance may be based on achievement of objectives, student participation, and the completion of student products. Suggestions for authentic assessment are included in an appendix. Checklists and criteria based evaluation scales have proven to be effective evaluation tools focused on "process" thinking skills rather than a completed "product." Further extensions of activities may be suggested. These could develop into additional activities for your class room or independent projects.





# An Overview of Poverty Point

Poverty Point is not the only mound building site in Louisiana. Our state and nation are gifted with an abundance of ancient earthworks constructed by the original inhabitants of our land. There are many different types of mounds which were built for various reasons by many different cultures of Native American peoples. Many of these are found along the Mississippi River and its connecting waterways and in the southeast region of the country.

The Poverty Point site is enormous in size, has unusual artifacts, and once was a major regional cultural center. Indians built the mounds and ridges there about 3,500 years ago. It is the largest earthworks site found in Louisiana, as well as one of the most fascinating. Poverty Point is an extremely important archaeological site which is still being excavated. At the current time, only about 1% of the site has been scientifically excavated, and many questions about ancient life at the site remain unanswered. The earthworks at Poverty Point are truly one of the state's most precious non-renewable resources.

The site was not called Poverty Point by its builders. We do not know what the mound builders called their home because they had no written language to tell us. The site was named after the Poverty Point plantation which occupied the same land at a much later time. The archaeological site at Poverty Point was the largest and most outstanding example of a group of sites. All of the sites having the same characteristics became known as Poverty Point Culture sites. Thus, the name Poverty Point may refer to either the Poverty Point site or the Poverty Point Culture.

The Poverty Point site is located in West Carroll Parish near the present day town of Epps, Louisiana. This is slightly northeast of Monroe, Louisiana.

The ridges and mounds composing the site were constructed on the Macon (mā sən) Ridge overlooking Bayou Macon (mā sən). The earthworks at Poverty Point include six concentric rings of ridges which border on the bayou, forming a C-shaped design around an enormous



plaza. The outer ridges are over 3/4 mile apart and currently range from about one to six feet high. More than 30 million basket loads of earth were needed to construct the mounds and ridges at the Poverty Point site. Each basket of soil would have weighed about 50 pounds. This adds up to a total of .75 million cubic yards of soil.

## The Mounds

Mound A is the tallest earthen structure at the Poverty Point site. This amazing mound is located along the western edge of the concentric rings of ridges and is thought by some to resemble a bird in flight. This is why some people call it the Bird Mound. It measures over 70 feet tall, 640 feet between the wing tips, and 710 feet from head to tail. Archaeologists have found evidence of basket loading construction on Mound A. This means that the mound was built by having basket loads of soil dumped on top of each other.

Several other mounds were built at the Poverty Point site. Motley Mound is located 1.5 miles north of the ridges. Its shape is similar to that of Mound A, but it is smaller. Motley Mound is oriented in a north/south position with a ramp-like "tail" extending to the south. Like Mound A, Motley Mound is sometimes called a bird effigy mound.

Mound B is a conical mound located .4 mile north of Mound A. It is shaped like a dome or the top of a cupcake. Mound B is 180 feet in diameter and 20 feet tall. Archaeologists in the 1950s partially excavated Mound B. They reported that Mound B was constructed in stages and that remains of baskets filled with soil were found on the upper surface.

Mound C (Dunbar Mound) is reported to have nine different stages of building in the bottom, rectangular part. There is also a dome of earth on top of the rectangular base. Evidence of wooden structures has been found in the nine basal levels. Archaeologists have discovered post holes there. A post hole is the hole where a wooden support post for a building once stood.

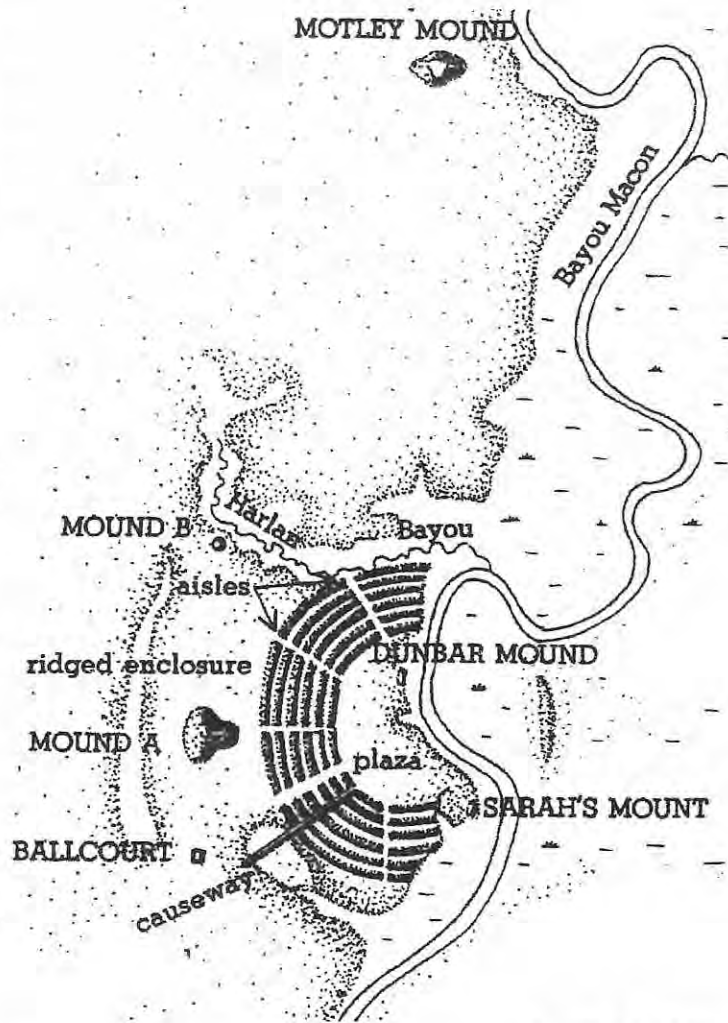

*drawing by Jon Gibson*

Mound D (Sarah's Mount) is a rectangular mound with a flat top. During recent historic times, this mound has served as a cemetery. Archaeologists have found Indian pottery at Mound D made 2,000 years later than most artifacts found at the site. It is possible that Indians built Mound D long after people constructed the other mounds at Poverty Point.

Mound E (Ballcourt Mound) is another platform structure at the site. It is a square shaped mound with sides measuring about 300 feet. The mound is called the Ballcourt because of its shape, but there is no evidence that the Poverty Point people used the mound for games.

### Characteristics of the Poverty Point Culture

All of the Poverty Point Culture sites share similar characteristics. These characteristics help us to understand how the Poverty Point people lived and worked. Archaeologists have identified these common ways of life in areas as far north as where the Mississippi and Arkansas rivers join, and south all the way to the Gulf coast. This includes parts of Louisiana, Mississippi, and Arkansas. Poverty Point tools and ornaments have also been found as far away as Tennessee and Missouri, along the Mississippi River, and as far east as Florida and Georgia. This is one indication that the Poverty Point people had an extensive trading network.

- Source Areas of Poverty Point Trade Materials**
- (A) Copper
  - (B) Gray Northern Flint
  - (C) Galena, Crescent Hills Chert
  - (D) Novaculite, Hematite, Magnetite, Quartz Crystal
  - (E) Citronelle Gravel
  - (F) Catahoula Sandstone
  - (G) Soapstone, Schist
  - (H) Tallahatta Quartzite
  - (I) Pickwick Chert
- Drawing by Denise A. Malter



*courtesy of Jon Gibson*

## Poverty Point Artifacts



Stone Point



Stone Hoe



Plummets



Microlith



Steatite Bowl

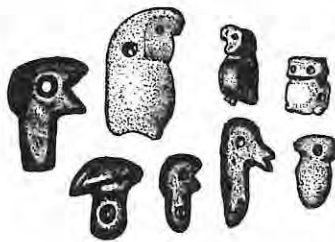

Stone Beads



Figurines

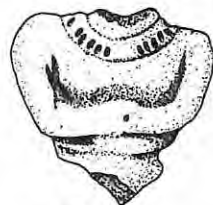

The Poverty Point Culture is primarily identified by its artifacts and the imported rocks used to make them. Rocks such as cherts, flints, soapstone, hematite, magnetite, and galena were brought in to be used in making tools and ornaments. Some of these rocks came from as far away as the Great Lakes and the Appalachian Mountains. The people trading these stones were linked by either streams or rivers connected to the Mississippi River. These streams and rivers formed a watery highway which was used to carry materials up to 1,400 miles.

Poverty Point people can also be identified by the many unique objects which they made. Rocks were used to make spear points, axes, hoes, and microliths. Microliths are small stone tools used as perforators or drill bits on pump drills.

Stones were also used to make other artifacts. These include large bowls carved from steatite, plummets used as weights on fishing nets, atlatl weights, beads, and pendants. Beads carved in the form of birds or small owls are also found at the site.

Cooking balls were hand formed from the local soil and used in earth ovens to help cook the food. In fact, archaeologists have found so many of these cooking balls that they are called Poverty Point Objects, or PPOs for short. Several different shapes of PPOs have been identified.

Clay figurines also have been found at the site. Models of females were formed by hand before being baked in a fire. Most of these clay figurines have had their heads knocked off. Archaeologists are uncertain of the reason, but hypothesize that the heads may have been removed at some important life event.

The activity handouts will provide more detailed information about these Poverty Point artifacts.

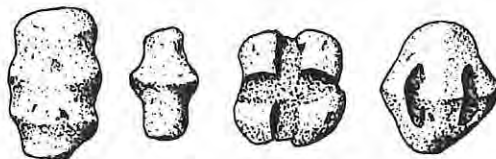

Cooking Balls or PPOs

Clarence H. Webb (1982)  
courtesy of LSU Dept. of  
Geography and Anthropology



## **Mounds throughout Prehistory**

The earthworks and mounds were built at Poverty Point around 1500 B.C. This was not the only era during which Louisiana Indians built mounds. Different types of mound building occurred before and after this time. Indians built round-top mounds as much as 2,500 years before the mounds and ridges were constructed at Poverty Point. At the Watson Brake site in Louisiana, archaeologists have found 11 mounds and ridges which connect them. These earthworks were built 2,000 years before Poverty Point. The mounds at Louisiana State University also predate Poverty Point.

Other types of mounds were built after Poverty Point. Later cultures constructed burial mounds and flat-topped temple mounds. The mounds at the Marksville State Commemorative Area are an excellent example of later mound building in Louisiana. There are other noteworthy mound sites in the southeastern and central regions of the United States. Studies of these mounds and cultures would surely intrigue students and provide outlets for independent research.

## **Site Protection**

All archaeological sites and artifacts on state and federal property are protected by law. Visitors to Poverty Point or other archaeological sites on public land should leave all artifacts and remains exactly as they were found. Even small broken artifacts and stains in the soil can give important clues about the people who once lived there. Help preserve Louisiana's heritage by reporting artifacts and possible sites to archaeologists. To contact an archaeologist, or to find out how to protect a site on private property, call the Division of Archaeology at 1-225-342-8170.

# Time Line of History

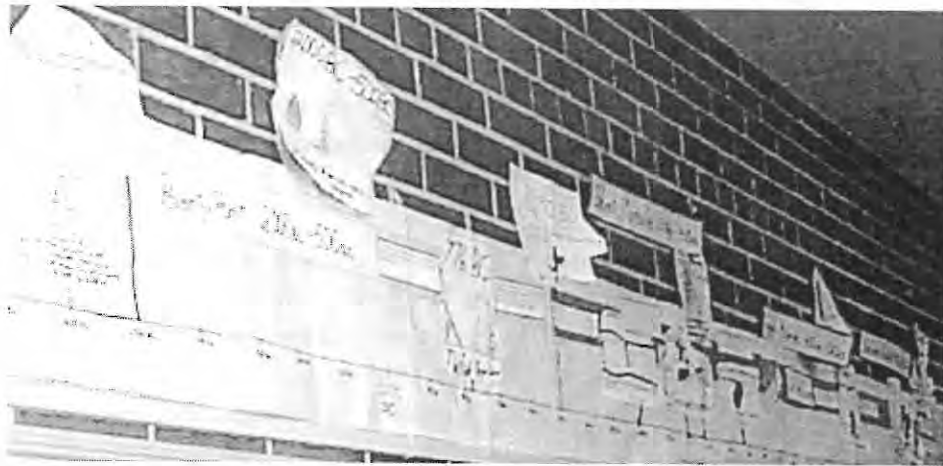

## Subject Areas:

Art, Language Arts, Math, Social Studies

## Objectives:

The student will:

1. Use the metric system to construct a time line.
2. Identify an important event in history through research, illustrate it, and determine its placement on the time line.
3. Use math skills to answer questions about time line events.

## Time:

Three one-hour class periods

## Materials:

Bulletin board paper

Glue

Metric rulers and meter sticks

Thin black markers

Markers

Paper

Scissors

Prehistory posters from Division of Archaeology (1-225-342-8170)

Reference materials: encyclopedias, time line books, computer software, etc.

## **Must Know Info:**

The earthworks at Poverty Point were built around 1500 B.C. Creating a time line of history will help students recognize the age of the Poverty Point earthworks and become aware of the other world history events occurring either before, during, or after Poverty Point was constructed. The Bering Strait land bridge was probably used by people to cross into North America around 30,000 B.C. to 12,000 B.C. Your time line could begin at this date or around 10,000 B.C., by which time Indians were in Louisiana. As students add events to the time line, they will notice that few events are noted during prehistory. Remind them that history begins when people have a written account of events.

The Division of Archaeology distributes a free set of prehistory posters which you can obtain for your classroom. These posters are excellent sources of information about the Paleo-Indian, Meso-Indian, Poverty Point, Early Neo-Indian, and Late Neo-Indian eras in Louisiana. The posters have illustrations of the artifacts, foods, and tools from each era. You will probably want to include information from these posters on your time line so that students will be aware of the Native Americans who lived in Louisiana both before and after the Poverty Point people. The prehistory posters could be hung next to the appropriate sections of the finished time line.

The Latin term "Anno Domini" means "in the year of our Lord." It does not mean after death, as many students believe. Introduce the term C.E. This stands for "common era" and is being used more frequently. Explain that our culture uses this system of dating, but that other cultures mark time by different calendars. Students may be interested in researching the Islamic, Hebrew, or other calendars and adding these comparisons to the time line.

## **Procedures:**

1. Before class, cut 12 sections of bulletin board paper with a length of 1.25 meters and a height of 40 centimeters. Each section will represent 1,000 years on the time line. This scale will result in a 12-meter time line if you begin your time line when Native Americans first entered Louisiana.
2. Introduce the concept of a time line and instruct students on the method of numbering before and after the zero on the time line.

Review the terms B.C., A.D., and C.E. Demonstrate ways of determining the amount of time between events on a time line by using arithmetic or by counting the years on the time line. It is important that students understand how to read a time line, especially when figuring out the amount of time between events in B.C. and A.D. Practice computing the amount of time between two B.C. events or two A.D. events by subtracting. Show student that they must add to find the amount of time between a B.C. event and an A.D. one.

3. Tell students that they will work together to construct a time line of history and illustrate it with pictures of events which have occurred throughout time. If research materials are limited, some students may work on marking the time line while others use the computer and/or reference materials.

4. Assign two or three students to each section of the time line and tell them which thousand year period to construct. For example, one group may be responsible for 2000 B.C. to 1000 B.C. Another group will have from zero to A.D. 1000.

5. Students will measure and draw a straight line 10 centimeters from the bottom edge of the paper. Next, students will measure and mark 100 centimeters on the time line. Every multiple of 10 centimeters should be drawn taller to help with counting. For example, the 10, 20, 30, etc. centimeter marks would be taller than the marks in between. After students have marked 100 centimeters, or one meter, they will have enough marks to represent 1,000 years on the time line.

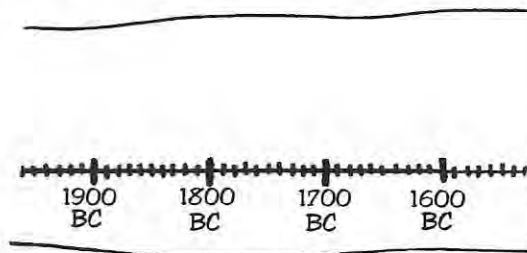

6. Students should label their large marks on the time line. Each 10 centimeter distance will equal 100 years. Caution students who are working on the B.C. sections of the time line to be careful when dating their time line. Of course, the B.C. sections are



numbered with the larger numbers to the left, but this may be unusual for many students.

7. When all sections of the time line have been completed, overlap the sections in order and glue them together.

8. Students will need to conduct research in various sources to find events to illustrate and place on the time line. Computer references, time table books, and history books are excellent. Each student should find one event to illustrate and place on the time line. The following events are examples of fun ones to use:

8500 B.C.	First pet dog
2717 B.C.	Zoser's step pyramid in Egypt
2000 B.C.	Ice cream invented in China
1343 B.C.	King Tut
776 B.C.	First Olympic games
A.D. 1492	Columbus reached North America
A.D. 1607	Pilgrims settled Jamestown
A.D. 1945	Explosion of the atomic bomb
A.D. 1969	Apollo moon landing

9. Be sure to include the following mound building dates:

3000 B.C.	Watson Brake Mounds in northeast LA
3000 B.C.	Campus Mounds at Louisiana State University in Baton Rouge, LA
A.D. 50	Mounds at Marksville State Commemorative Area in Marksville, LA
A.D. 1200	Mounds at Grand Village of the Natchez in Natchez, MS

10. Make up time line math problems which correlate with the events. Either present these orally to the class or make up individual worksheets. This will assist you in evaluating whether the students understand the concepts presented. Some examples follow:

1. Find the picture of the first ice cream. When was it first invented?
2. What letters are used with the dates that come after the year zero?

3. It is now the year \_\_\_\_\_. Our school was built in \_\_\_\_\_. How old is our school?
4. Circle the one which happened the longest ago.  
Atomic bomb OR the first pet dog?
5. How many years have passed between the building of Zoser's step pyramid in 2717 B.C. and the eruption of Mt. Vesuvius in A.D. 79? (Tricky because one date is B.C. and the other is A.D.)

11. Leave your time line up and gradually add to it as you study additional cultures.

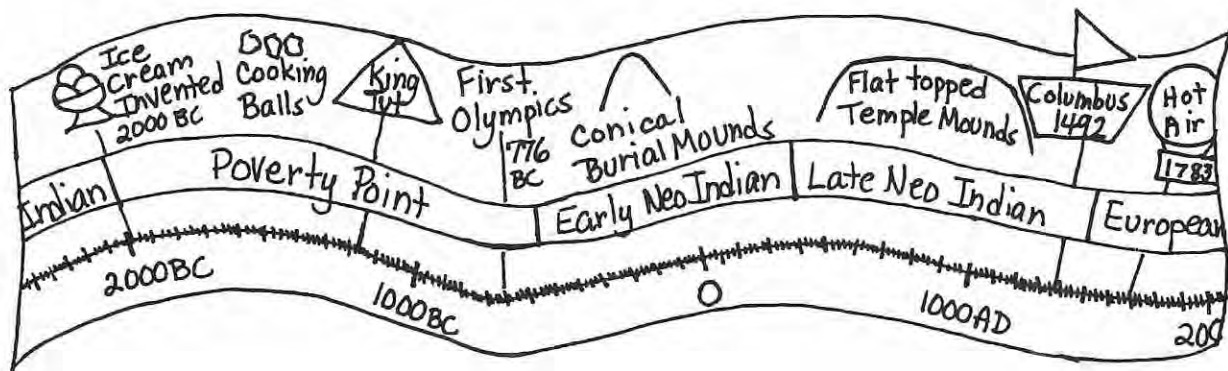

# Our Poverty Point Addresses

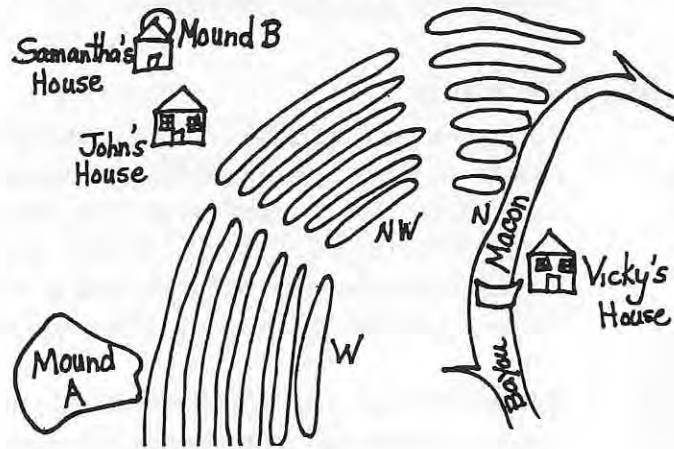

## Subject Areas:

Art, Language Arts, Math, Social Studies

## Objectives:

The student will:

1. Utilize mapping skills to locate addresses on a community map and an overlay map of the Poverty Point ridges.
2. Use a map scale to determine the distances between locations at Poverty Point and between student addresses.
3. Superimpose the Poverty Point site map on a neighborhood map to determine the relative size of Poverty Point compared to the neighborhood.
4. Practice using different scales to determine distances on a map and to discover that the distance between two places remains the same even when the scale changes.

## Time:

One hour to trace neighborhood map  
Two hours to complete student activity

## Materials:

Overhead projector  
*Map of Poverty Point* overhead transparency  
Map of local neighborhood with map scale given in miles  
Large sheet of white paper  
Blank overhead transparency sheet for neighborhood map

Marker that writes on plastic  
18 inch square of clear plastic for Poverty Point overlay map  
Small round label for each student

### Must Know Info:

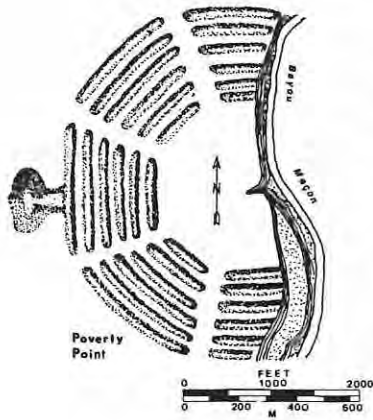

Clarence H. Webb (1982)  
courtesy of LSU Dept. of Geography and Anthropology

The man-made earthworks at the Poverty Point site near Epps are enormous. The six earthen ridges are arranged in concentric arcs surrounding a large central plaza. The ends of the outermost ridges are 3,950 feet apart, or almost 3/4 mile. The distance across the plaza between the inner ridges is about 1,950 feet. The earthworks form a C-shaped pattern which ends at the bluffs of Bayou Macon.

The semicircular ridge which is closest to the central plaza is called Ridge 1. The ridges are numbered going outwards so that the longest outer ridge is called Ridge 6. The site is also divided into sections by aisles which crosscut through the ridges. These sections are known as the north, northwest, west, southwest, and south sections of the Poverty Point site. The dividing aisles do not divide the earthworks into sections of equal size. The aisles are from 35 to 160 feet wide.

In order to give students a better understanding of the immense size of the site, superimpose a clear plastic Poverty Point map on top of a neighborhood map and let the students determine where they would live. Poverty Point addresses may be formed by naming the section and the ridge number, for example, a student might live in the Southwest Section on Ridge 3. Once students have discovered each others' Poverty Point addresses, the immense size of the site will be clear as they ride their bicycles through the neighborhood!

### Procedures:

1. Make an overhead transparency of the Poverty Point map included in this lesson.
2. Make an overhead transparency of the neighborhood map with a scale in miles.
3. Tape the clear plastic sheet to a wall, project the Poverty Point map on it, and trace in permanent marker. Be sure to include the map scale and compass directions.

4. Project the neighborhood map so that it shines on top of the Poverty Point clear plastic. Move your projector forward or backward until both map scales are the same. When the map scales are the same, do not move your projector.
5. Do not move the projector as you take the plastic down and put up white paper to draw the neighborhood map.
6. Trace the neighborhood map onto the white paper. Label a few major streets to provide points of reference for the students.
7. Students will enjoy labeling the streets, bayous, major landmarks (Burger King, McDonalds), and the location of the school. Students will need to create a map key and color code highways, interstate systems, rivers, railroads, etc.
8. Students should use round labels to find and mark the location of their homes. This is an excellent opportunity for map skills review and instruction in compass directions, map scale, and giving directions from one location to another. Make up questions similar to those below or let students quiz each other:
  1. What bayou is north of our school?
  2. If you leave Chase's house and travel south on Hwy. 44, how many miles is it to Airline Hwy?
  3. Use the map scale to find the distance from Lauren's house to Stephanie's house as the crow flies.
9. Place the plastic map of Poverty Point on top of the neighborhood map and adjust it so that the school is on a ridge and that as many children's houses as possible are covered by the plastic. Keep the directional orientation so that North is still North, etc.
10. Students will look for their labels on the neighborhood map and determine which ridge and section they would live on at Poverty Point. Each student will identify his Poverty Point address and mark it on the clear plastic map of the site.
11. Students will enjoy making little huts from card stock to put on the Poverty Point plastic map. Tape or hot glue the huts on the plastic overlay above the labels on the neighborhood map. The students really enjoy knowing who lives in what section of the Poverty Point site! Since many students are able to ride bicycles or



walk around their neighborhood, this activity will give them a clearer picture of the immense size of the Poverty Point site.

12. Use the overhead transparency of the Poverty Point map to help teach map scale. Project the map of Poverty Point on the wall and have students use a string to determine the distance between two locations on the map. Use the map scale to measure the string, finding the actual distance between the locations. Next, move the projector so that the map scale becomes either larger or smaller. Use the string to once again measure the distance between the same two locations. The measurement on the string will be different. Ask students if the distance between the places has changed. They should figure out that the scale will have changed along with the projected map. Students should check this out by measuring the string on the altered map scale. Compare the two projections of the Poverty Point map and inquire about the advantages of one or the other. Students should notice that a map scale covering less distance results in a close up picture of the same area.



# Map of Poverty Point

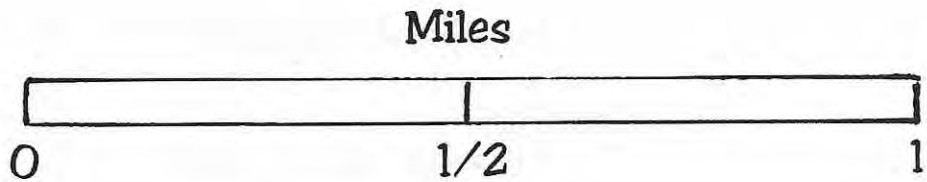
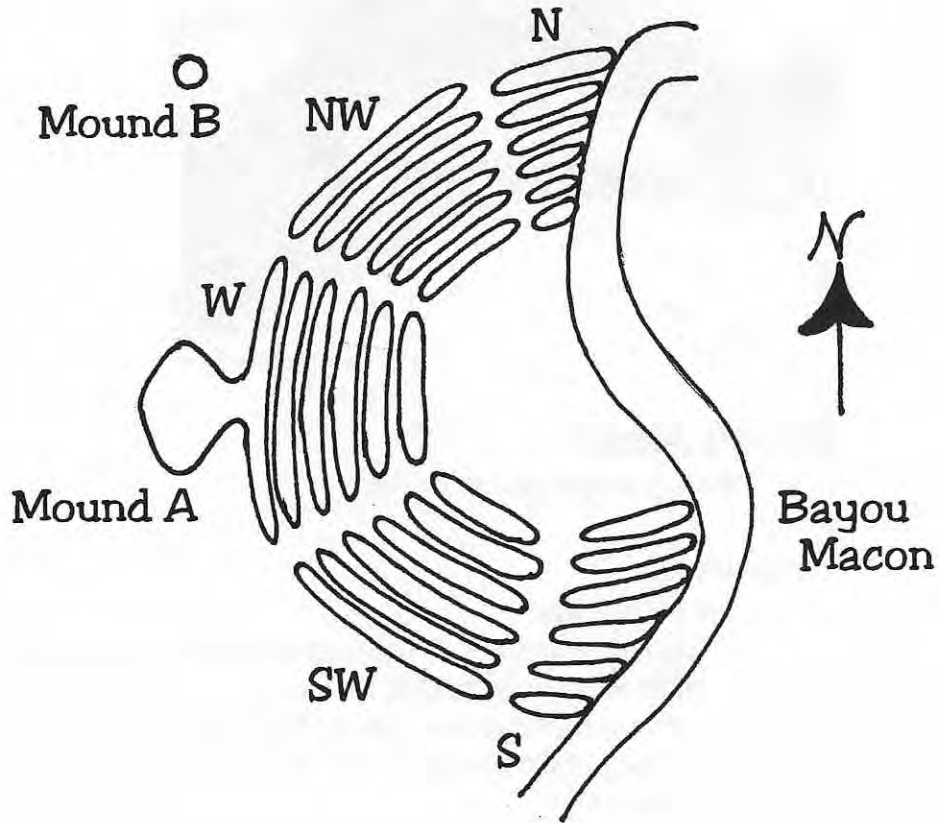

# Topography Training

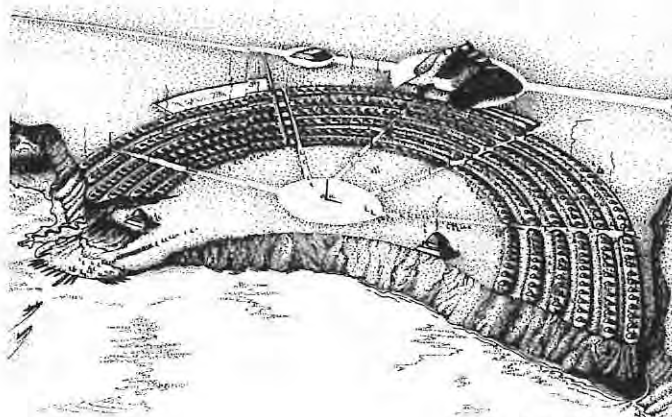

*drawing by Jon Gibson*

## Subject Areas:

Math, Science, Social Studies

## Objectives:

The student will:

1. Explore mapping techniques to construct a topographic map of a simple mound constructed from clay.
2. Analyze a map of Mound A to find information about the topography of the site and to conclude if the mound's shape does resemble a bird.

## Time:

Two one-hour class periods

## Materials:

*Topography Training* handout  
Clay, play dough, or homemade recipe of dough  
Ruler  
Dental floss  
Pencils  
Card stock or poster board  
Scissors

## Must Know Info:

*Topography Training* is the first of three lesson plans designed to teach students about topography and to demonstrate the immense size of the Poverty Point site. *Topography Training* will allow students to create their own topographic map from a clay model after learning topography basics. The second lesson, *Building a Mound for the Birds!*, will result in the construction of a cardboard model of Mound A based on a topographic map of the site. A final activity is *The Run for the Ridges* in which students run a 50-yard dash and use the map scale to determine what this distance would be on the model.

A topographic map is a type of physical geography map which shows the elevation of the land by connecting points with the same elevation to form a line. These curvy lines are superimposed upon a two-dimensional map to give a three-dimensional view of the landscape. Students will be able to determine the height of the land as well as distances from east to west, etc.

Look carefully at the Mound A topographic map. Notice that there are elevation lines given for every five feet, beginning with an elevation of 100 feet. The highest elevation for the mound according to the map is 165 feet. These measurements do not indicate elevations above sea level. Notice that the caption for the map states that "the reference point was given an assumed elevation of 100 feet." This point became the "benchmark" for the surveyors. They simply measured the elevation above or below this arbitrary point. The elevation of the land around Mound A is 95 feet or lower.

Mound A is the tallest earthen structure at the Poverty Point site. This amazing mound is located along the western edge of the concentric rings of ridges and is thought by some to resemble a bird in flight. This is why some people call it the "Bird" Mound. It measures over 70 feet tall, 640 feet between the wing tips, and 710 feet from head to tail. Over 30 million basket loads of earth were needed to construct the mounds and ridges at the Poverty Point site. Each basket of soil would have weighed about 50 pounds. This adds up to a total of .75 million cubic yards of soil used to construct the mounds and ridges at the site.

## Procedures:

1. Assign students to cooperative groups for the *Topography Training*. Have students analyze the student handout of the Mound A topographic map. Remind students that this is a kind of physical map called a topographic map. Determine prior knowledge by asking students what the curvy lines and numbers on the map mean. If necessary, explain that this kind of map depicts changes in elevation. The curvy line connects points on the map which are at the same elevation and the numbers tell the elevation.
2. Ask students to look carefully at the map of the "Bird" Mound and to share their observations. What lines on the map would support the idea that this mound was built in the shape of a bird? Where is the highest point on the mound located? Are the wings of the bird at a similar elevation? What about the tail?
3. Each group will begin an exploration of topographic mapping techniques by building a small mound from clay. Limit student building to a simple mound that resembles an upside down cone for this introductory activity. Students should save more complicated mountains for later.
4. Distribute a *Topography Training* handout to each cooperative group. Students will follow the directions to build their own mound and draw a topographic map of it.
5. After the topographic maps are completed, groups may reassemble their mounds and display these next to their maps. Remind students that their mounds will never be exactly the same after being cut up for mapping. The same thing holds true for archaeological excavations. Once the mound has been excavated, it can never be returned to exactly what it was before. This is why mounds are called "nonrenewable" resources. They can't be replaced.



# Topography Training

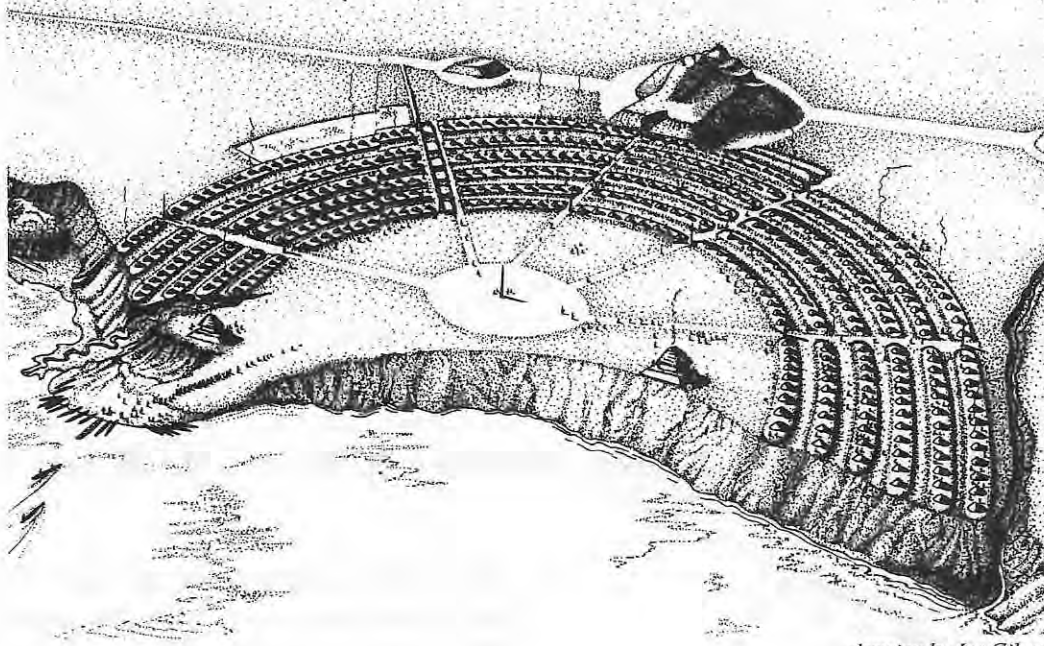

Imagine that it is some time between 2000 B.C. and 1000 B.C.! You are living with your family at the Poverty Point settlement in what will later become northeastern Louisiana. Halfway across the world, King Tut is a little boy playing by the banks of the Nile. Stonehenge is being built in England and Hammurabi is thinking about the first laws for ancient Babylon. Construction has begun at Poverty Point on the sacred "Bird" Mound and you are hoping to be chosen to help. Every day you watch the workers as they make countless trips up the side of the growing mound, tossing basketfuls of soil on the top of the pile and stomping the dirt down with their bare feet.

Of course, we aren't really living in the distant past and we won't be moving the 30 million basket loads of earth which would be needed to construct the mounds and ridges at Poverty Point. But you can construct a scale model of the mound so that you can see just how BIG the "Bird" Mound and ridges at Poverty Point really are!

Before you are allowed to become a sacred "Bird" Mound builder, you must complete topography training by building and mapping a conical mound. A conical mound has a circular base and sides which slope up to a narrow top. Mound B is a prominent mound found at Poverty Point which is called a conical mound. It is really more the shape of an upside down cereal bowl

because it is about 180 feet in diameter and only 20 feet tall. Your mound will not be scaled to the same size as Mound B because you are just practicing the basics of topography! Do your best and qualify to be a sacred "Bird" Mound Builder!

### Materials:

- Clay
- Ruler
- Dental floss
- Pencils
- Card stock or white paper
- Scissors
- Cardboard base for clay mound

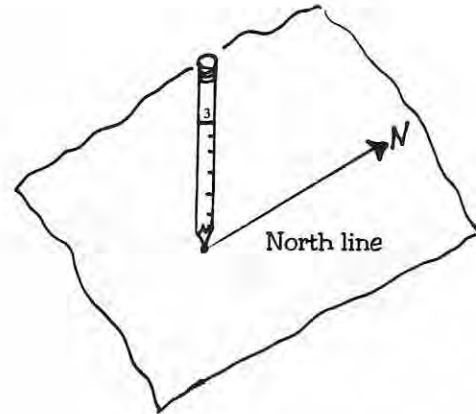

### Directions:

1. Place a large dot in the center of a piece of card stock or white paper. This will be the location of the tallest part of your mound.

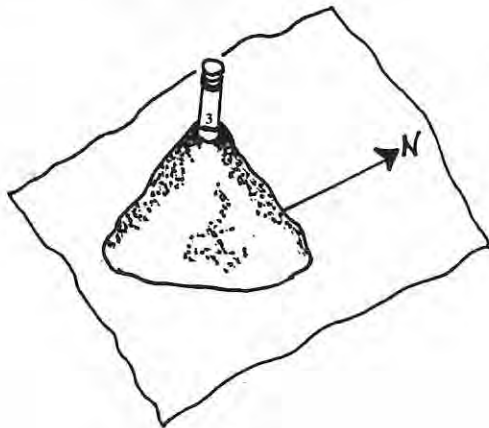

2. Use a ruler to draw a straight line from the dot to the edge of the paper. Label the end of the line North. You may add the other compass directions if you like.

3. Measure three inches up the pencil from its tip and mark it with a pen. The mark will be the tallest part of your mound.

4. Hold the marked pencil straight up and down (vertically) on top of the dot while another group member surrounds the pencil with clay to build your mound. Make sure to keep the pencil right on top of the dot. Keep adding clay until the top of the mound reaches the three-inch mark on the pencil.

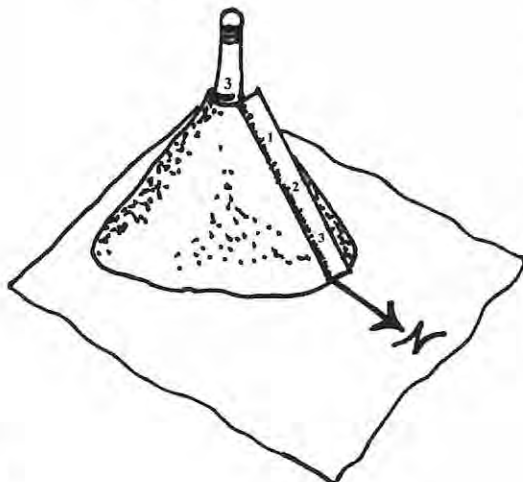

5. Lean a ruler along the side of the mound to connect the North line on the paper and the pencil in the top of the mound. Draw a light line in the clay from the top of the mound to the

North mark. Remove the vertical pencil from the center hole. Do not cover the hole because you will need it later.

6. Trace around the base of the mound and label this paper as ground level elevation.

7. Get two unsharpened pencils. Use a ruler to measure one half inch from the ends of the two pencils. Make marks on the pencils. Tie a six inch piece of dental floss between the two pencils at the marks. Hold the pencils straight up and down so that the floss is stretched tightly between them. Slide the tips of the pencils along the surface, slicing horizontally through the clay mound at a height of one half inch.

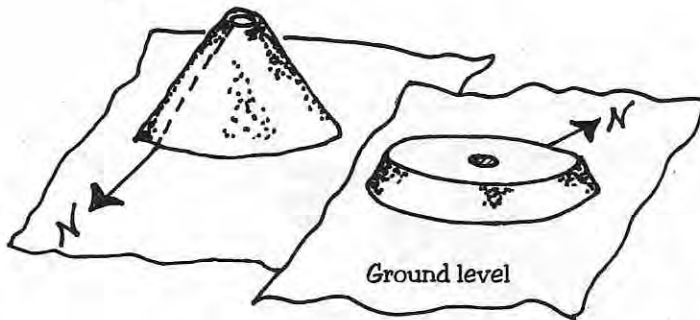
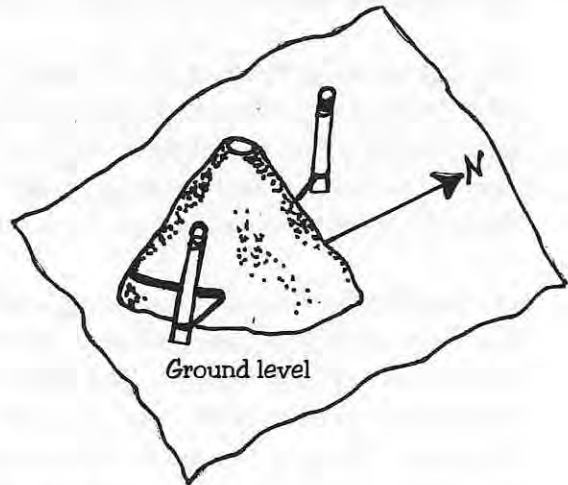

8. Gently pick up the top section of the mound and place it on a different piece of paper. Trace around the bottom edge of the clay and mark North on the paper next to the North line cut into the clay.

9. Stick a pencil down in the hole to make a dot at this location. Do not skip this step because you will need the pencil dot later to help you line up all of the levels on your map. All of the map levels will be lined up to match at the

middle pencil dots and the North direction lines. Label this part of the topographic map as Level One (one half inch above ground level.)

10. Hold the pencils tightly apart and slice through the mound again. Remove the top section of the mound and leave the slice. Place the mound on a new piece of paper. Once again, trace the outline at the bottom of the mound slice and mark North. Stick a pencil down the vertical hole and mark a dot on the paper. Label this part of your map as Level Two (one inch above ground level.)

11. Continue measuring, slicing, and tracing your mound slices at elevations of one and ½ inches, two, and two and ½ inches above ground level. The pencil hole at the three inches above ground level elevation will be the highest point displayed on your map. You should have six map circles drawn on different pieces of paper.



12. Carefully remove the clay slices from the paper.
13. Cut out all of the map layers which you traced on paper. Place the map layers on top of each other in ascending order from ground level to three inches above ground level. Line up the map layers so the center pencil point marks and the marks for north are right on top of each other. Draw a line around the hole to show the elevation of your mound at three inches above ground level. Glue the pieces of the map down to form a topographic map of your group's mound.
14. Reassemble your mound, taking care to match the center holes and the North marks. Display your topographic map next to your mound. Because your clay mound can never really be put back together exactly like it was before cutting, it is like a real earthen mound after an archaeological excavation. Once the mound has been excavated, it will never be the same again. Because of this, archaeologists called mounds "nonrenewable" resources. Archaeologists are careful to record everything they do, so that the information about the mounds can be saved forever.

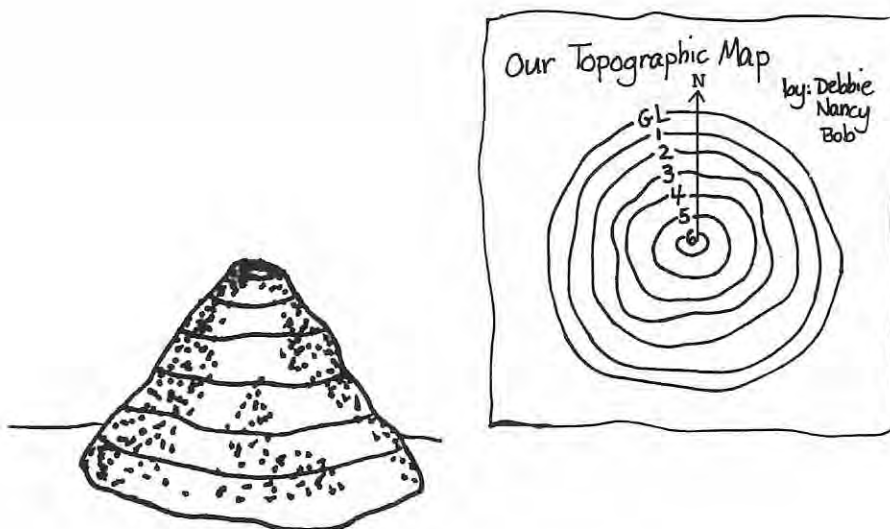

## Mound A Topographic Map

Look carefully at the topographic map of Mound A below. Notice that there are elevation lines given for every five feet, beginning with an elevation of 100 feet. These measurements do not indicate elevations above sea level. Notice that the caption for the map states that "the reference point was given an assumed elevation of 100 feet." This point became the "benchmark" for the surveyors. They simply measured elevation above or below this arbitrary point.

Some people think that the topography of Mound A looks like a bird shape. That's why Mound A is sometimes called the "Bird" Mound! What do you think? Is this nickname justified?

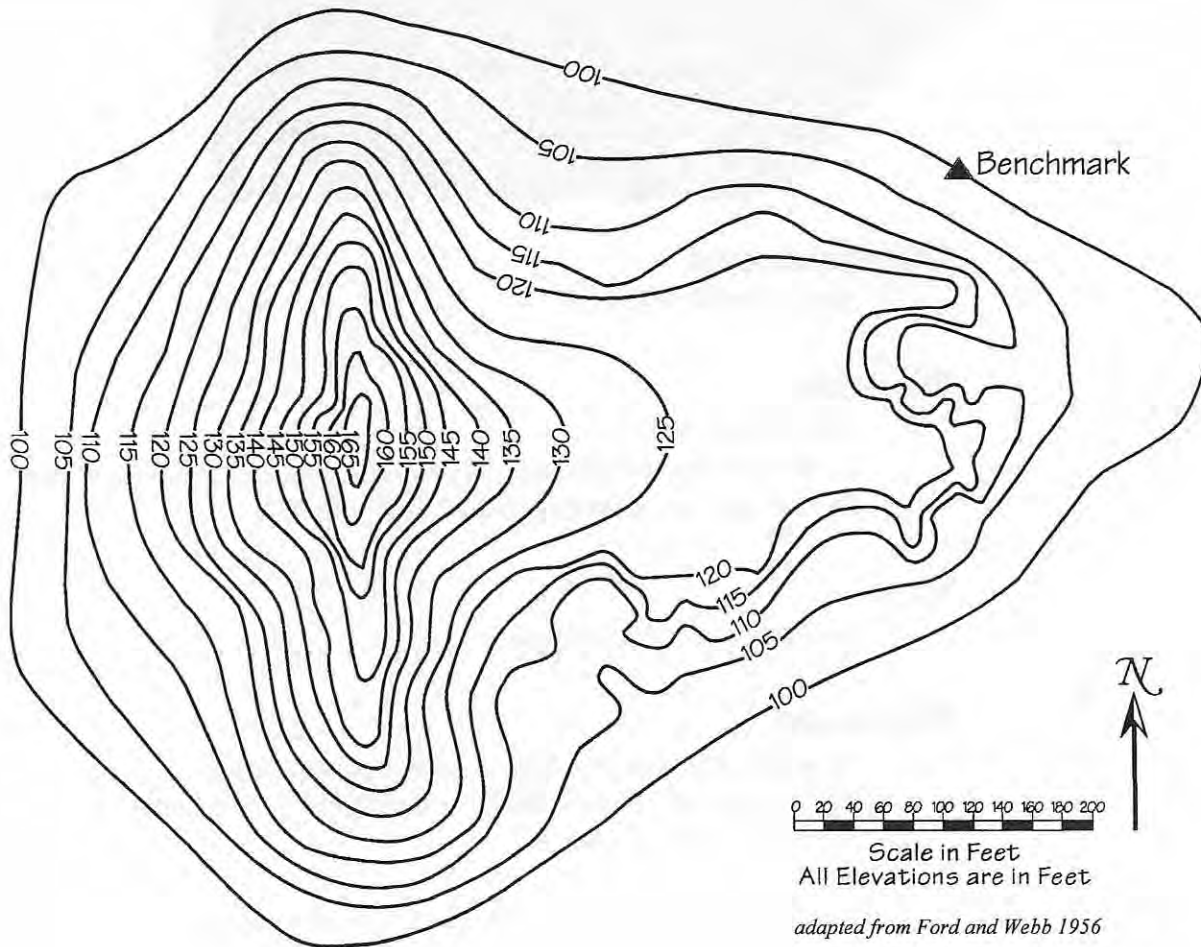

Contour map of Poverty Point Mound. The reference point was given an assumed elevation of 100 feet.



# Building a Mound for the Birds!



## Subject Areas:

Math, Social Studies

## Objective:

The student will:

1. Use the topographic map of Mound A to construct an accurate three-dimensional model of the "Bird" Mound.

## Time:

Two one-hour class periods

## Materials:

*Mound A Topographic Map* overhead transparency  
Eight pieces of 1/8 inch thick cardboard (18 x 24 inches)  
Scissors or exacto knife  
Glue  
Cardboard base for model (at least 24 inches square)  
Tape for the classroom floor  
Matchsticks, tiny beads, or other objects which are 1/8 inch tall

## Must Know Info:

This lesson is the second of three related activities on topography and creating a model of the Poverty Point site. *Topography Training*, the first lesson, was designed to teach students about topographic maps. The second lesson, *Building a Mound for the Birds!*, will result in the construction of a cardboard model of Mound A based on a topographic map of the site. A final activity will be *The Run for the Ridges* in which students run a 50-yard dash and use the map scale to determine what this distance would be on the model.

A topographic map is a type of physical geography map which shows the elevation of the land by connecting points with the same elevation to form a line. These curvy lines are superimposed upon a two-dimensional map to give a three-dimensional view of the landscape. Students will be able to determine the height of the land as well as distances from east to west, etc.

Look carefully at the Mound A topographic map. Notice that there are elevation lines given for every five feet, beginning with an elevation of 100 feet. These measurements do not indicate elevations above sea level. Notice that the caption for the map states that "the reference point was given an assumed elevation of 100 feet." This point became the "benchmark" for the surveyors. They simply measured the elevation above or below this arbitrary point. The elevation of the land around Mound A is 95 feet or lower.

Mound A is the tallest earthen structure at Poverty Point. This amazing mound is located along the western edge of the concentric rings of ridges and is thought by some to resemble a bird in flight. This is why some people call it the "Bird" Mound. It measures over 70 feet tall, 640 feet between the wing tips, and 710 feet from head to tail. Over 30 million basket loads of earth were needed to construct the mounds and ridges at the Poverty Point site. Each basket of soil would have weighed about 50 pounds. This adds up to a total of .75 million cubic yards of soil used to construct the mounds and ridges at the site.

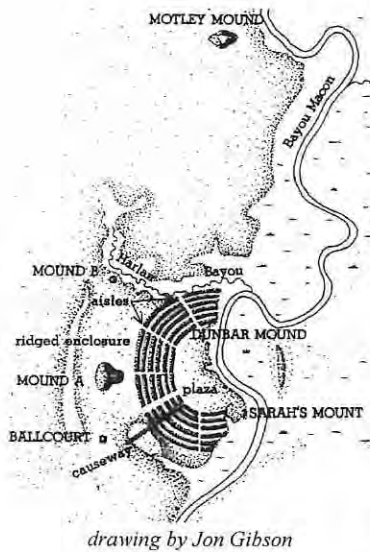

Several other mounds were built at the Poverty Point site. Mound B is a conical mound located .4 mile north of the "Bird" Mound. It is shaped like a dome or the top of a cupcake. Mound B is 180 feet in diameter and 20 feet tall. Motley Mound is located 1.5 miles north of the ridges. It seems to be in the shape of a bird, but it is smaller than Mound A. Motley Mound is oriented in a north/south position with a ramp-like "tail" extending to the south. Other mounds at the site include Mound D (Sarah's Mount), which is located next to the southern ridge section, and Mound E (Ballcourt Mound), a flat-topped structure about 300 feet square. Students might enjoy researching these mounds and constructing models of them to add to the class display.

Building an accurate model of the "Bird" Mound will enhance student understanding of the immense size of the site when compared with the height of a person. A scaled version of a five foot tall Poverty Point person will demonstrate the relative size of humans to the site because the person would only be 1/8 inch tall. The scaled model will be about 20 inches long and 15 inches wide. This is approximately 800 feet in length and 625 feet in width according to the scale.

The size of the Poverty Point site will be illustrated by adding tape to the floor to show the six concentric ridges at the site. The outermost edges of the ridges are 3,950 feet apart (nearly 3/4 of a mile.) The ends of the inner ridges are 1,950 feet apart. The ridges now are about one to six feet high and over 100 feet broad. The Poverty Point site, shown on this scale, would measure over eight feet across the outer ridges (98.7 inches) while a person would be proportionally scaled to 1/8 inch tall, the width of a match stick cut into little cubes or a small bead. These items may be added to the display to simulate people. This amazing difference should really demonstrate the enormous size of the archaeological site.

### Procedures:

1. Students will work in pairs to construct a three-dimensional cardboard model of the "Bird" Mound at Poverty Point using a topographic map as a guide. Each pair of students will build one elevation level of the topographic map and combine it with others to construct a class model of the "Bird" Mound. There are 14

elevation levels. Assign a pair of students to each elevation level such as 100, 105, 110, etc.

2. Tape the transparency of the Mound A Topographic Map on the overhead projector and adjust the size of the picture as follows. Using 1/8 inch thick cardboard to make this model, 200 feet on the scale should be enlarged to equal five inches on the projected image. In this way, 1/8 inch on the scale equals five feet on the model. Use a ruler to measure the projection of the scale on the wall and move the projector either closer or farther away until the scaled distance for 200 feet is five inches. This is the scale used to compute the distances given for the ridges and the 1/8 inch scaled person.

3. Student groups will need to take turns tracing their elevation levels from the overhead projection. Instruct students to hold or tape a piece of cardboard to the wall so that the map is projected on it. The students will need to trace both their assigned elevation and the elevation above it. Tracing the next elevation level will create a pattern to show where the next elevation level should go when students are assembling the model. Caution students to avoid jiggling the overhead projector as this will mess up the scale.

4. Tell students to cut out their piece of cardboard on the lines for their elevation. When all students have traced and cut out their pieces of cardboard, they will need to glue the levels together to form Mound A. Each upper elevation level piece will be glued to fit in the lines on the lower level. Glue the model on the cardboard base which would have an elevation level of 95 feet. Be sure to mark the direction north and draw in the map scale key.

5. After the "Bird" Mound has been constructed, challenge students to use the same scale to construct a two-dimensional model of the entire Poverty Point site on the floor of the classroom. The location of the ridges could be measured and marked with tape or a cardboard model could be built. Let students compute the scaled distances by themselves. Students could make a "compass" from a piece of string and a pencil to draw the outer ridges with a diameter of 3,950 feet. Remember that the ends of the inner edge ridges are 1,950 feet apart.

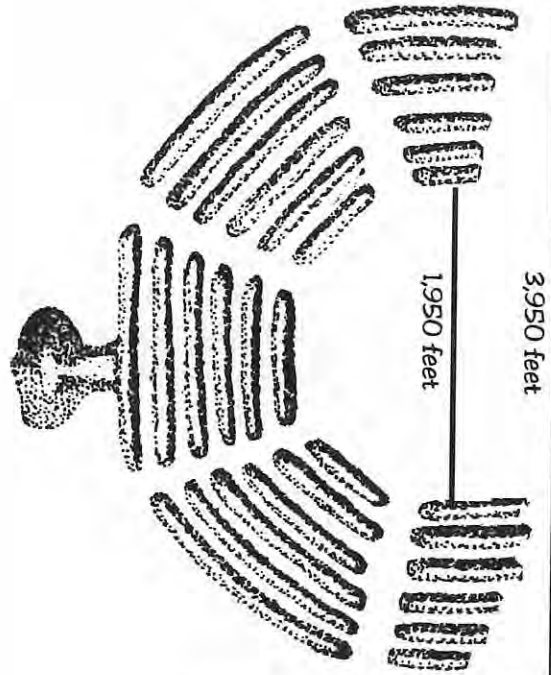

*adapted from Clarence H. Webb (1982) map*

Information for the 1/8 inch cardboard model is provided below for checking student work:

1/8 inch = 5 feet

1 inch = 40 feet

The "compass" should have a radius of about 49 inches to make the outer ridges and 24 inches to make the inner ridges. The ridges made to scale would stand about 1/8 inch tall. Poverty Point people drawn to scale would be about 1/8 inch tall. Find objects which are about 1/8 inch tall to simulate people. The width of a matchstick or a tiny bead would be about the correct size. Using this scale, the model will take up about eight feet of your classroom floor.

6. Some students may enjoy researching Mound B, Mound C (Dunbar Mound), Mound D (Sarah's Mount), and Mound E (Ballcourt Mound) before adding these to the display.



# Mound A Topographic Map

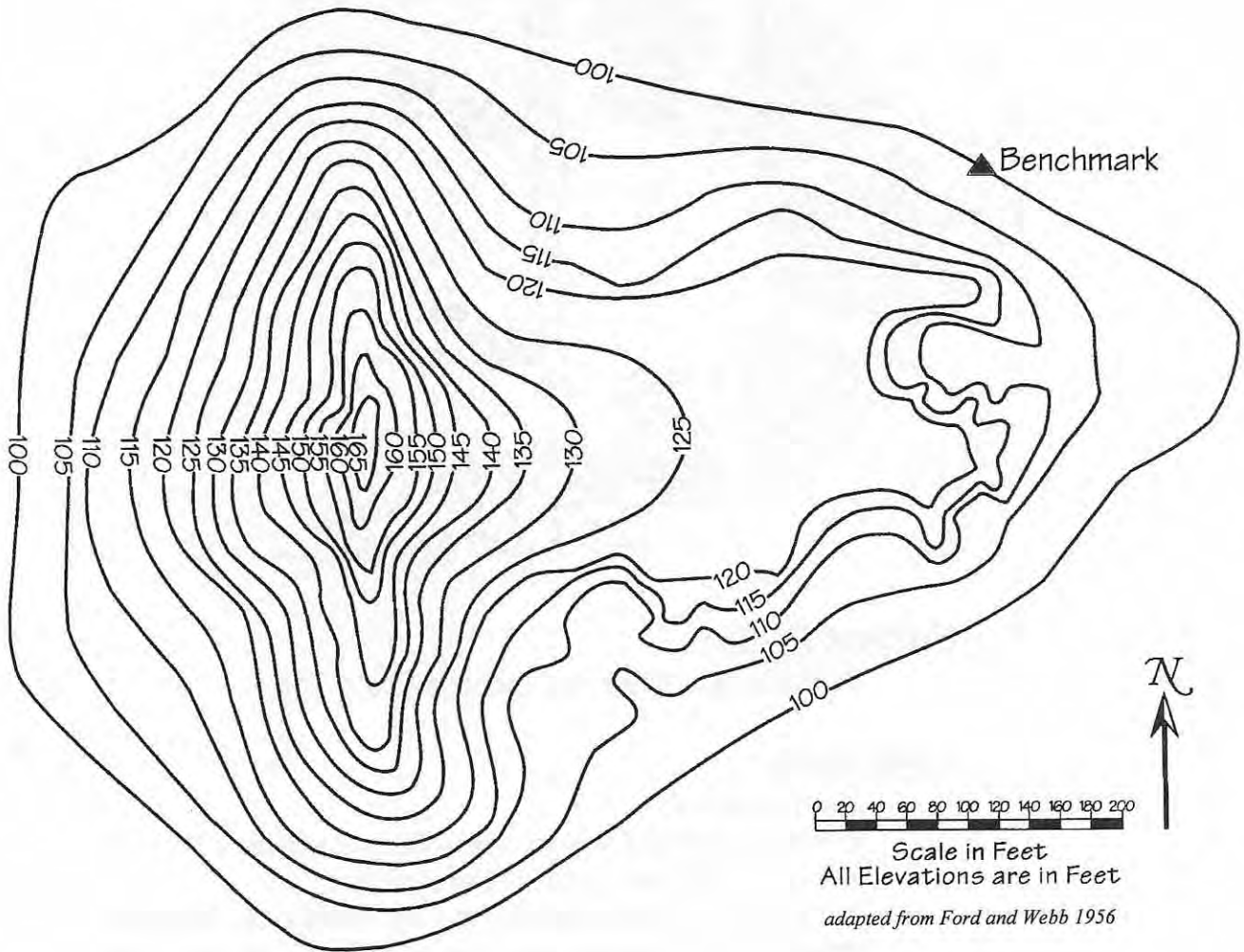

Contour map of Poverty Point Mound. The reference point was given an assumed elevation of 100 feet.

# The Run for the Ridges

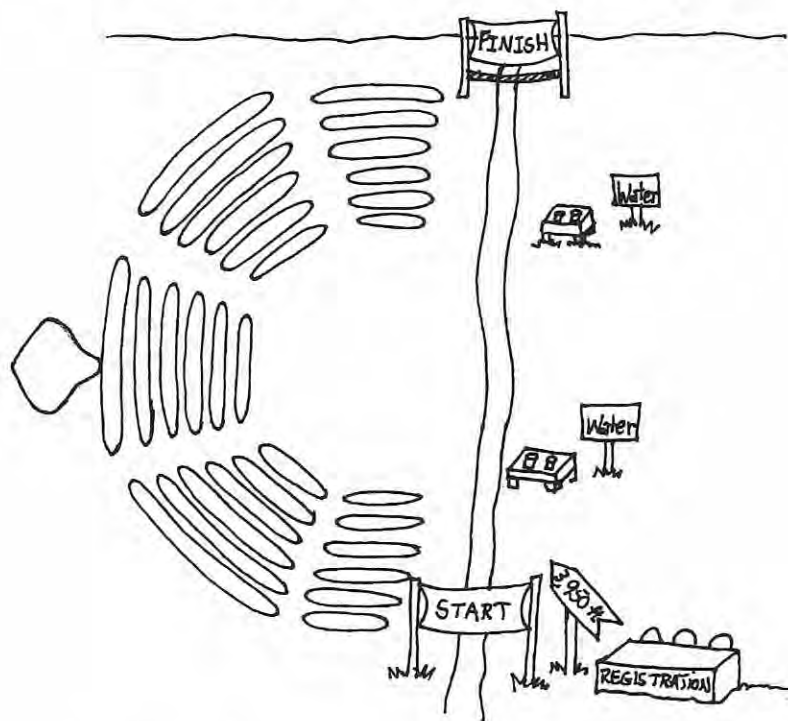

## Subject Areas:

Math, Physical Education, Social Studies

## Objectives:

The student will:

1. Utilize math and map reading skills to determine a 50-yard distance on the scale model of Poverty Point.
2. Use math and problem solving skills to calculate the amount of time it would take to run across the ridges based on the student's race time in the 50-yard dash.

## Time:

Two one-hour class periods

## Materials:

50-yard measuring tape  
Stop watch  
Paper and pencil for recording times

## Must Know Info:

This lesson is the third of three related activities on topography and creating a model of the Poverty Point site. *Topography Training*, the first lesson, was designed to teach students about topography. The second lesson, *Building a Mound for the Birds!*, resulted in the construction of a cardboard model of Mound A based on a topographic map of the site. This final activity will challenge students to do *The Run for the Ridges* in which they will run a 50-yard dash and then use the results to determine the amount of time it would take to run the diameter of the ridges at this speed. Students will also use the map scale to determine what this distance would be scaled to on the model.

## Procedures:

1. Measure and mark a 50-yard race course on the playground or an open area. Look for obstacles like holes, ant piles, etc. before marking your course.
2. Introduce *The Run for the Ridges* to students as a fun way for them to see just how big the Poverty Point site really is! Tell students that they will be timed while they run the 50-yard dash and that later they will use their race time to find out how long it would take them to run from the southernmost ridge to the most northern one at Poverty Point.
3. Use a stop watch to measure and record student times for the 50-yard dash. If possible, obtain more than one stop watch and run multiple students at the same time. Students who know how to operate a stop watch may serve as timers.
4. After the races, brainstorm with the class to find how long the 50-yard dash would be on the scaled version of the Poverty Point model from the *Building a Mound for the Birds!* activity. If  $\frac{1}{8}$  inch cardboard was used in that activity, then  $\frac{1}{8}$  inch equals 5 feet on the scale,  $\frac{1}{4}$  inch equals 10 feet,  $\frac{1}{2}$  inch equals 20 feet, 1 inch equals 40 feet, etc. Students can continue in this manner or use division. In either case, the answer is 3.75 inches. Remind the class that the scaled distance across the outermost ridges is 98.7 inches and listen to the groans when you suggest that they run the entire distance!

5. Tell students that they may use math to determine how long it would take them to run the entire ridge race, assuming that they didn't get tired, take water breaks, or slow down one little bit! Challenge students to figure out how to solve for the amount of time in hours and minutes that it would take to travel the entire distance across the ridges. Remind students that the distance between the outermost ridges is 3,950 feet and that they have a race time for the 50-yard dash. If necessary, guide students to the discovery that 50 yards is equivalent to 150 feet. This is a very complex problem involving several steps. It may also be successfully solved in a number of ways. Let students attempt this on their own in order to develop thinking and problem solving skills.

6. For checking purposes, the following information may be helpful. Dividing 3,950 feet by 150 feet (50 yards) equals 26.33. Therefore, the student may take his race time for the 50-yard dash and multiply it by 26.33 to get an approximate time for *The Run for the Ridges*. Students would need to take that time in seconds and convert it to hours and minutes. To convert from seconds to minutes, the student will need to divide the number of seconds by 60 to get the number of minutes. To convert from minutes to hours, the student would need to divide the number of minutes by 60 to get the number of hours. In both cases, left over seconds and minutes should not be ignored. This is a terrific multi-step math problem which requires thought to determine which math operation is called for and a working knowledge of time concepts. If necessary, give students some hints, but do try to let them struggle to success with it. Another option would be to allow students to work with a partner or a cooperative group to solve the math problems.

# Home, Home on the Ridge



## Subject Areas:

Art, Math, Social Studies

## Objectives:

The student will:

1. Work cooperatively in a small group to construct a life-sized palmetto hut similar to those the Poverty Point people may have built.
2. Create and subdivide a large circular base for a hut using a compass and concepts of fractions and geometry.
3. Use the natural resources available in the lower Mississippi Delta to construct a simple dwelling.

## Time:

Approximately five-one hour class periods

## Materials:

*Home, Home on the Ridge* student handout

Approximately 16 willow branches (8 to 10 feet tall)

Bark peeled off of the willow branches in thin strips or string

Lots and lots of palmetto leaves



Indoor hut: A large piece of cardboard, at least 8 feet in diameter,  
glue gun, exacto knife  
Outdoor hut: Post hole digger or digging sticks

### Must Know Info:

Although many students may think that all Indians lived in teepees, this is not true of the Louisiana Native Americans. The Poverty Point people used the natural resources available to them to construct their dwellings. Some of these natural resources were the trees, **palmetto** branches, and the soil around them. These same resources are still available today in many places throughout Louisiana. At the present time, no archaeological remains of houses have been found at the Poverty Point site. This may be due to the extensive amount of farming which has taken place at the site.

**palmetto:**  
a kind of palm with fan-shaped leaves; common in southeast USA

Other Poverty Point Culture sites exist throughout Louisiana, Mississippi, and Arkansas. The remains of dwellings have been found at one of these sites. **Post holes** were excavated at Jaketown, a Poverty Point Culture site in Mississippi. Archaeologists recognized the post holes by the different color of the soil. The post holes at Jaketown formed a circular shape which was about 12 to 14 feet in diameter. This indicated that the building there was about 12 to 14 feet across.

**post hole:**  
an archaeological feature; the hole where a wood post once stood

Archaeologists think that the people probably lived on top of the six concentric ridges at Poverty Point. These C-shaped, hill-like ridges are thought to have been about twice as high when they were constructed. Today, they have been worn down to heights of one to six feet due to erosion and years of plowing.

We can not be sure what Poverty Point dwellings really looked like, but the palmetto hut in this lesson was common among the descendants of the Poverty Point people. The size of the hut which the students will build is smaller than the one found at Jaketown, but it is big enough for students to enjoy because they can go inside. Four or five students can sit comfortably in a palmetto hut with a diameter of seven to eight feet. The hut may be constructed either inside or outside your classroom. To build the hut indoors, place it on a cardboard base and use the cardboard "corners" that protect furniture during shipping and hot glue to hold your willow branches in place. A visit to the trash bin of your local furniture

**wattle and daub:**

wattle refers to woven branches forming the framework of a wall; daub is the mud covering the wattle

store may be necessary. The willow poles can be stuck into the ground if you build your hut outside.

The model of a **wattle and daub** hut in the *Wattle You Build Next?* activity uses similar building techniques, but uses mud for walls instead of palmetto.

### Procedures:

1. Ask students what kinds of homes were built by Louisiana Native Americans. (No teepees) Ask students what kinds of natural resources would have been available to the Louisiana Indians to use as building materials. (Trees, palmetto, grasses, soil.) Ask students to think of natural resources they could find today to build a survival hut in the Louisiana woods. (Same resources - palmetto, trees, grasses, soil.)

2. Tell students that no archaeological remains of houses have been found at the Poverty Point site. This may be due to the extensive amount of farming which took place at the site. However, post holes have been found at another Poverty Point era site at Jaketown, Mississippi. The post molds at Jaketown form a circular shape which is about 12 to 14 feet in diameter.

3. Review information in the *Home, Home on the Ridge* handout. Students may work together to build a palmetto hut as a class project or work in small groups to construct a wattle and daub model hut described in *Wattle You Build Next?* The palmetto hut in *Home, Home on the Ridge* may be built either inside or outside of the classroom.

**diameter:**

measurement through the center of a circle

**radius:**

a line going straight from the center of a circle to the outside of a circle

4. Teach students how to use a compass to draw a circle and let them practice on scratch paper. Discuss the terms **diameter** and **radius** and make sure that all students understand the terms. Use a piece of string tied to a thumbtack on one end and a pencil on the other to make a gigantic compass. Let students practice using this gigantic compass to draw circles on a piece of cardboard. This will form the pattern for the palmetto hut.

5. Follow directions in the handout to build a palmetto hut about seven feet in diameter.

**circumference:**  
distance around a circle

6. As students begin to build the palmetto hut, have them estimate the number of palmetto leaves they will need. In order to do this, they may want to figure the **circumference** of the circle using the following formula:  $circumference = 2 \pi r$ . Students could check out the formula by measuring the distance around the circle with a piece of string.

7. A fun follow-up activity would be to have students draw a circle 12 feet in diameter and try to fit their family's belongings in the "hut." Students could draw life-sized beds, chairs, TVs, etc. within the boundaries of the hut. As all of their stuff will probably not fit into the available space, this may lead to an evaluation of which things are essential and which could be eliminated. Students may also begin to question how much time ancient people spent inside their dwellings compared to our own culture.

8. When the hut is finished, students will enjoy using the inside as a work space for other projects.

## Home, Home on the Ridge



Poverty Point people were at "home on the ridge" because their dwellings were probably built on top of the ridges at the site. There are six concentric circular earth ridges at Poverty Point. These C-shaped, hill-like ridges are thought to have been about twice as high when they were first built. Today, they are only about one to six feet high because of years of erosion and plowing.

No archaeological evidence of houses has been uncovered at Poverty Point. This does not mean that the people living there failed to construct dwellings. Louisiana's wet climate may have decayed the remains which archaeologists are seeking. Other sites have the remains of buildings. Post holes have been found at Jaketown, a Poverty Point site in Mississippi. The house there was in the shape of a circle about 12 to 14 feet in diameter.

The people living at Poverty Point would have used the materials in their environment to build their homes. Louisiana has an abundant supply of willow trees, river cane, palmetto leaves, grass, and mud. These natural resources are excellent materials for building simple but effective homes.

A "life-sized" palmetto hut can be made from a framework of willow branches covered with palmetto leaves. This hut will be smaller than the one at Jaketown, but large enough to be an actual home. You may build your hut either inside or outside. If you build your hut inside, you will need to construct it on top of a large piece of cardboard and use cardboard corner scraps and hot glue to hold your willow poles. If you build your hut outside, dig holes in the ground and stick your willow poles in them. Follow these simple directions to build a life-sized palmetto hut!

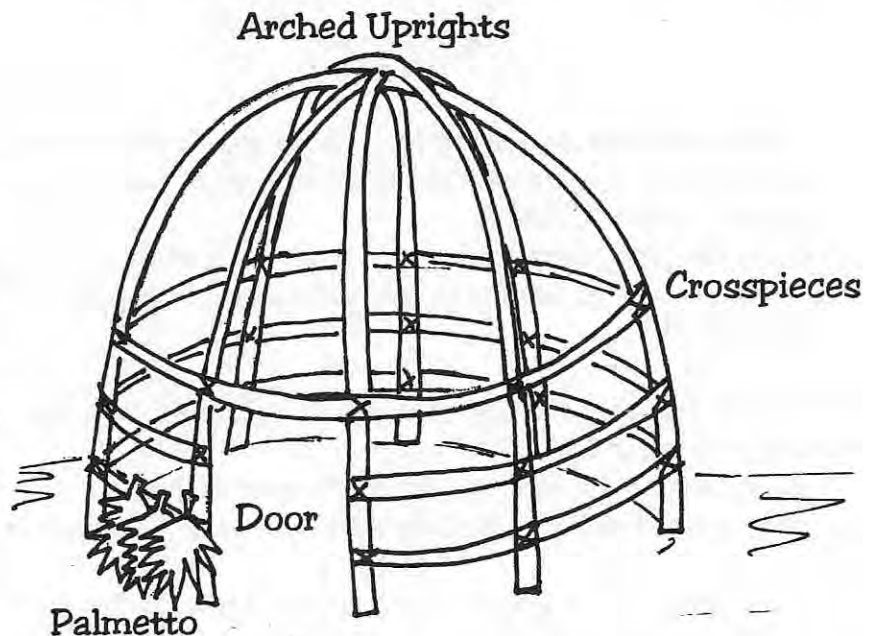

## Materials:

Eight willow branches, each 10 feet tall, for the uprights

About eight willow branches for the crosspieces

Bark from the willow branches or string

Lots of palmetto leaves

Indoor hut: a large piece of cardboard for the base, cardboard corner scraps to secure the framework, hot glue gun, and exacto knife

Outdoor hut: post hole digger or a digging stick to dig holes for the framework

## Directions:

1. Use a string and a pencil as a large compass. Draw a circle on either the cardboard (inside) or the dirt (outside.) The diameter of the hut can be as big as you like. Experiment with the different diameters because a larger diameter will result in a shorter hut. All of your willow poles will need to be the same length.
2. Divide your circle into eight equal parts by marking halves, fourths, and eighths.



Marks for Post Holes

3. Dig eight holes for your upright poles along the circumference of the circle.

Outside: Use a digging stick just like the Poverty Point people may have done or use a post hole digger to make your holes.

Inside: Hot glue a cardboard corner square scrap along the diameter of the circle where you want the "hole." Ask an adult to use an exacto knife to "dig" the hole by cutting into the scrap piece of cardboard.

4. Build the upright section of your hut by placing two willow branches in the holes on opposite sides of the circle.

Outside: Stomp dirt back into the hole around the pole.

Inside: Squirt hot glue in the hole before you place the branch in it.

5. Bend the two opposing branches so that they form an arch. Overlap the branches and tie them together at the top with a strip of willow bark or string. Continue with steps 4 and 5 until you have connected all four pairs. Tie the pairs together at the top of the house.



6. Add horizontal crosspieces around the sides of the hut by tying branches to your uprights. The distance between the crosspieces will be determined by the size of your palmetto leaves. The palmetto leaves should overlap each other, so the distance between the layers of crosspieces should be slightly less than the measurement of the palmetto leaves from the stem to the tip. This will probably be about one foot.

7. Leave room between two of the uprights for a door into your hut.

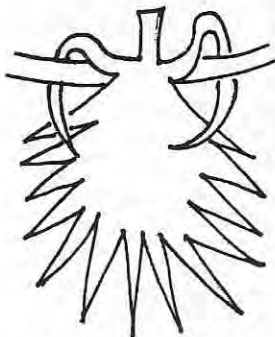

Loop ends over crosspiece



Tie a square knot



8. Tie a palmetto leaf to the bottom crosspiece. Use the end spikes on the palmetto as string by tearing them all the way to the stem (if they break off, just use the next spike.) Put both palmetto spikes over the crosspiece and then bring them back to the front of the palmetto leaf. Tie the spikes together in a square knot (right over left, then left over right) on top of the palmetto leaf.

9. Continue tying palmetto leaves on the crosspieces, overlapping them so the rain won't get in your house. Each palmetto leaf acts like a little umbrella. When you get all around the bottom level of the house, begin tying leaves on the next level up, making sure that the top leaves overlap the ones on the lower level. Continue adding levels of crosspieces and palmetto leaves until you get to the top!

10. Leave a smoke hole at the top of your house, but DO NOT build a fire in your hut! Remember that the real huts were 12 to 14 feet in diameter.

# Wattle You Build Next?



## Subject Areas:

Art, Math, Social Studies

## Objectives:

The student will:

1. Work cooperatively in a small group to construct a model wattle and daub hut similar to those the Poverty Point people may have built.
2. Use the natural resources available in the lower Mississippi Delta to construct a simple dwelling.

## Time:

One hour

## Materials:

*Wattle You Build Next?* student handout

Wire basket from the garden center or other framework material

4 inch grapevine wreath to be taken apart or collected vines

8 inch square of foam board or thick cardboard for a base

Mud or clay

4 inch squares of green printer paper or construction paper

Glue gun or craft glue

Scissors and stapler

Wire cutters

## Must Know Info:

This activity works well in conjunction with the *Home, Home on the Ridge* activity of building a full sized palmetto hut. Students may work in cooperative groups to build the wattle and daub model from this activity while a few students at a time work on the palmetto building.

**palmetto:**

a kind of palm with fan-shaped leaves; common in the southeast USA

Although many students may think that all Indians lived in teepees, this is not true of the Louisiana Native Americans. The Poverty Point people used the natural resources available to them to construct their dwellings. Some of these natural resources were the trees, **palmetto** branches, and the soil around them. These same resources are still available today in many places throughout Louisiana. At the present time, no archaeological remains of houses have been found at the Poverty Point site. This may be due to the extensive amount of farming which has taken place at the site.

**post hole:**

the hole where a wood post once stood

Other Poverty Point Culture sites exist throughout Louisiana, Mississippi, and Arkansas. The remains of dwellings have been found at one of these sites. **Post holes** were excavated at Jaketown, a Poverty Point Culture site in Mississippi.

Archaeologists recognized the post holes by the different color of the soil. The post holes at Jaketown formed a circular shape which was about 12 to 14 feet in diameter. This indicated that the building there was about 12 to 14 feet across.

Archaeologists think that the Poverty Point people probably lived on top of the six concentric ridges at the site. These C-shaped, hill-like ridges are thought to have been about twice as high when they were constructed. Today, they have been worn down to heights of one to six feet due to erosion and years of plowing.

**wattle and daub:**

wattle refers to woven branches forming the framework of a wall; daub is the mud covering the wattle

A full sized **wattle and daub** hut would use the same construction techniques as the palmetto hut described in the *Home, Home on the Ridge* activity. However, in a wattle and daub hut the wall would be made by weaving limbs, grass, or moss into the uprights of the house before caking it with mud. The mud covering is called daub. It may help your students discriminate between wattle and daub if you remind them of the dirt dauber, a familiar insect, who builds her nest with mud. The mud daub would have insulated the house

and kept the people living there warm during the winter. The roof of a wattle and daub house would most likely have been made of either woven grass mats or palmetto leaves.

The model wattle and daub hut is being constructed from a wire flower basket which is usually sold to hold a moss lining. This works well because it provides the basic framework needed for the model hut, but allows students the opportunity to weave grapevine wattle between the wires. Other purchased frameworks such as Easter baskets or colanders will work. Students may also create a framework using flexible willow branches or vines. Clay or real mud may be used for the daub. The roof of the model is made from green paper folded into palmetto leaves.

### **Procedures:**

1. If your class is not working on the *Home, Home on the Ridge* activity in conjunction with this one, the following introduction will be necessary.
2. Ask students what kinds of homes were built by Louisiana Native Americans. (No teepees) Ask students what kinds of natural resources would have been available to the Louisiana Indians to use as building materials. (Trees, palmetto, grasses, soil.) Ask students to think of natural resources they could find today to build a survival hut in the Louisiana woods. (Same resources - palmetto, trees, soil, grasses)
3. Tell students that no archaeological remains of houses have been found at the Poverty Point site. This may be due to the extensive amount of farming which took place at the site. However, post holes have been found at another Poverty Point era site at Jaketown, Mississippi. The post molds at Jaketown form a circular shape which is about 12 to 14 feet in diameter.
4. Place students in cooperative groups and distribute materials and *Wattle You Build Next?* handouts. Review directions given on handout for constructing the model of a wattle and daub hut.
5. Monitor student progress. Some students may want to make a roof from woven grass mats. Encourage them to develop a technique of weaving thatch and to research thatched roofs.

## Wattle You Build Next?



Wattle and daub huts were constructed from a framework of flexible branches covered with a mud mixture to form the walls. Branches were woven into the sides of the house before it was covered with mud. The mud would have insulated the house and kept the people living there warm during the winter. The word “wattle” refers to the woven branches and the word “daub” means the mud plastered around the wattle. Think of the dirt dauber, a familiar insect which builds its home from mud.

A model of a wattle and daub hut can be constructed using a wire flower basket, thin grapevine, mud or clay, and green paper. Follow these directions to see “wattle” you build!

### Materials:

- Wire basket from the garden center
- 4 inch grapevine wreath to be taken apart
- 8 inch square of foam board or thick cardboard for a base
- Mud or clay
- 4 inch squares of green printer paper or construction paper
- Craft glue
- Scissors
- Stapler
- Wire cutters

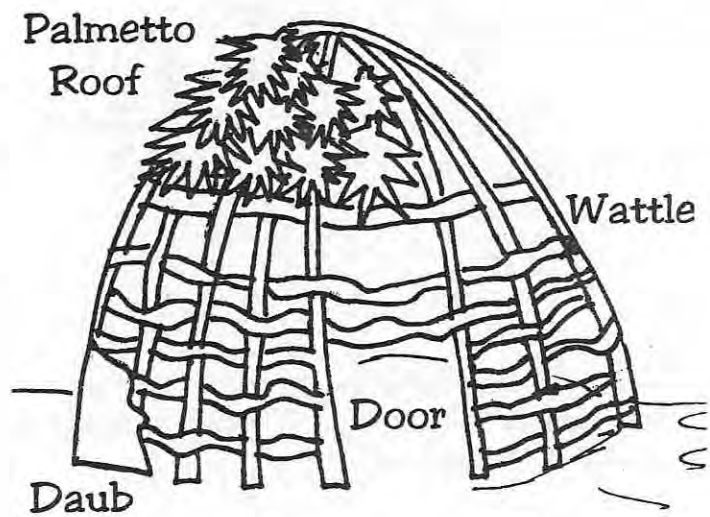

### Directions:

1. Ask an adult to use wire cutters to cut a doorway for your hut.
2. Turn the wire basket upside down. Push the wires into the foam board or cardboard so that it will not move.
3. Unravel the grapevine wreath. Use the thin vines from the wreath to weave between the vertical wires on the basket frame. Use a simple over and under weave to cover the empty spaces between the uprights.
4. Cover the sides of the hut with mud or clay. This will keep the hut warm and block out cold breezes.



5. Make paper palmetto leaves to go on your roof. First, cut out a square of green paper about four inches on each side. Fold the paper accordion style like a paper fan. Use little folds. Staple the fan at the top. Leave the paper folded for now. Now take your scissors and cut diagonally across the bottom from one side to the other. When you open the fan, you should have a palmetto leaf. Make lots of these for your roof.

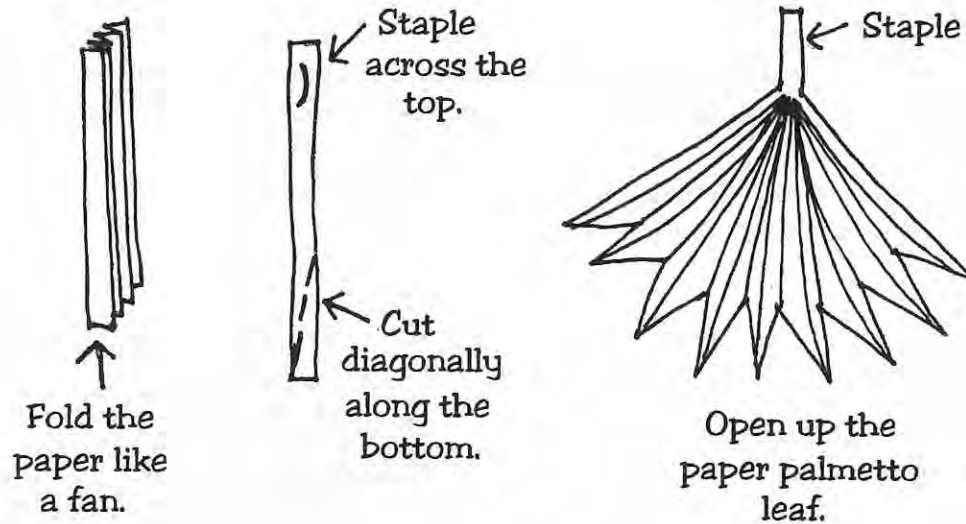

6. Use craft glue to attach the paper palmetto leaves to the roof of the hut. These need to overlap so that the rain won't come in. Overlap the sides of the palmetto leaves and overlap each top layer over the bottom ones.

7. The roof of the hut could also be made out of woven grass mats. Try these instead if you like and then write directions to show a friend!

# Atlatl Antics



## Subject Areas:

Math, Science, Social Studies

## Objectives:

The student will:

1. Use the scientific method to experiment, gather and record data, analyze results, and draw conclusions about the effect that lengthening the throwing arm has on the distance that he can throw a clay disk.
2. Simulate the advantage of using an atlatl to achieve greater speed.

## Time:

Two one-hour class sessions

## Materials:

Clay disk thrower  
Clay disks  
Measuring tape  
*Atlatl Antics* handout (one for each group of five)  
String or rope measuring 4 feet (one for each group of four)  
Overhead transparency of *Atlatl Antics* simulation

## Must Know Info:

Modern hunters still use a tool very much like one used by the Poverty Point people. A hand-held clay disk thrower can be found in the hunting department of many stores during the fall. This modern-day hunting tool is used to throw clay disks into the air for target practice. About 3,500 years ago, the Poverty Point people used a spear thrower called an **atlatl**. The atlatl started being used thousands of years before Poverty Point was built. It was still used around A.D. 400 when Louisiana Indians began adopting the bow and arrow.

**atlatl:** (at' la təl)  
a stick used to hold the end of a spear; used to throw spears

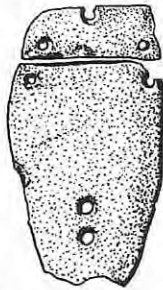
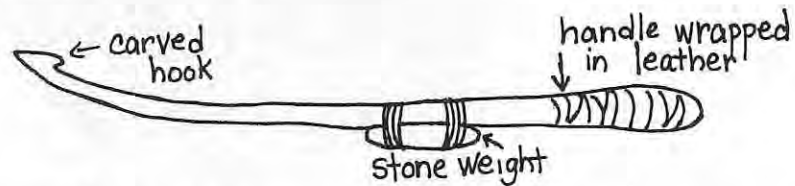

**Bannerstone  
or Atlatl  
Weight**

Clarence H. Webb (1982)  
courtesy of LSU Dept. of  
Geography and  
Anthropology

An atlatl helped the hunter throw his spear because it gave him a "longer" throwing arm and greater throwing speed. Atlatls have been described as shaped like "oversized crochet needles" because they were about two feet long with a hook at the spear end. The back end of the spear fit into the atlatl. Sometimes an atlatl hook was made of deer antler and attached to the wooden atlatl to hold the spear in place. Stone weights were attached to the middle of the atlatl to add more force to the throwing arm. These are called bannerstones or atlatl weights.

The hunter would hold the spear in place with his thumb and pointer finger, while the other fingers maintained a steady hold on the atlatl. The spear was thrown by using an overhand motion similar to casting a rod and reel or serving a tennis ball. At just the right time, the hunter would let go of the spear and send it toward its target. One of the trickiest things about using an atlatl is holding onto the atlatl when you let go of the spear.

## Procedures:

1. Tell students that hunters today are still using a tool that is very much like the one used by the Poverty Point people. Show them the clay disk thrower and ask if any of them have used it for target practice. Read and discuss the first four paragraphs of the *Atlatl Antics* handout to find out how the clay disk thrower is similar to the atlatl. Discuss when the atlatl was used by ancient peoples, what it looked like, and how the spear was thrown.

2. Divide students into groups of four to complete the atlatl simulation using a string or rope. Make sure the students understand their roles and the directions for the simulation. Each student should have a turn acting as the shoulder, the hand, the atlatl, and the observer.

3. Show students the overhead transparency of the atlatl simulation while reading or paraphrasing the following directions for the atlatl simulation.

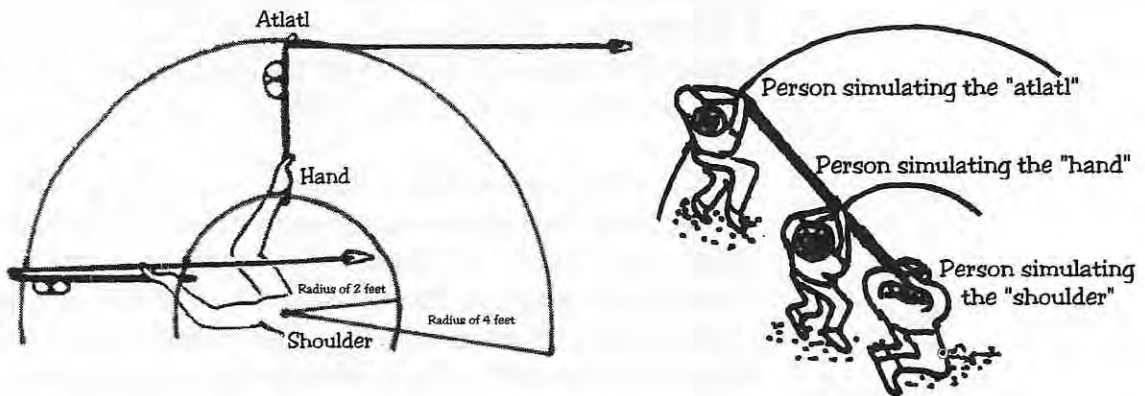

*Try this to feel the movement of the atlatl for yourself! You will work in a small group of four students to simulate the rotation of the hand and the atlatl around the shoulder joint. When the atlatl is thrown, its motion is in the shape of an arc pivoting around the shoulder joint. You will get to make the same kind of pivoting motion around a group member. One person will pretend to be the hand and observe how fast the spear would travel if the hand threw it. Another group member will pretend to be the atlatl and observe how fast the spear would travel if the atlatl threw it. Decide whether the hand or the atlatl throws the spear faster. Group members may take turns simulating the hand, atlatl, and shoulder. The fourth group member is the observer.*

*Measure and cut a piece of string or rope which is four feet long. Place a mark in the middle of the string, two feet from both ends. The "shoulder joint" member will kneel down while holding the tip of the string stationary on top of his head. The "hand" person will hold the string securely at the two foot measurement, and the "atlatl" person will hold the end of the string (four feet from the "shoulder joint" person.)*

*The "atlatl" person must keep the string taut at all times while walking in a circle around the "shoulder joint" person. The "hand" person must keep pace with the "atlatl" person. The observer will stand at the starting point on the circle and note which person is traveling faster. Go around several times to see who is traveling faster! Now trade places and try it again. Could you feel the difference?*

This demonstrates how throwing with an atlatl increases the speed of the dart as it is thrown. A dart which is thrown from an atlatl the length of your arm would travel approximately twice as fast as a dart thrown by the hand. For an even more vivid simulation, increase the length of the radius for the atlatl to about six feet. The larger the radius, the faster the "atlatl" will travel.

4. Form atlatl teams with five students on each team. Students will follow the instructions on the handout to compete in Atlatl Antics. Each student will throw two clay disks by hand. Teammates will measure the distance thrown and all students will record the data. Next each student will throw two clay disks using the clay disk thrower, again measuring and recording data. Students will compute the averages of each of the two kinds of throws.

5. Each student will create a horizontal bar graph to plot the team's results. A handout of the graph is on page 53. Each group will share its results and conclusions about the advantages of having a longer throwing arm. A whole class graph could be created by combining all of the group graphs on the bulletin board.



# Atlatl Antics Simulation

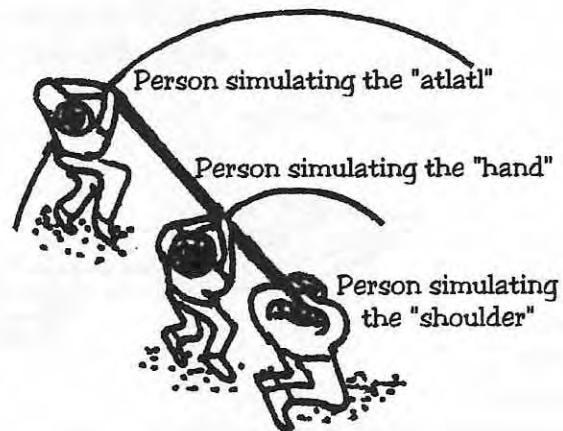
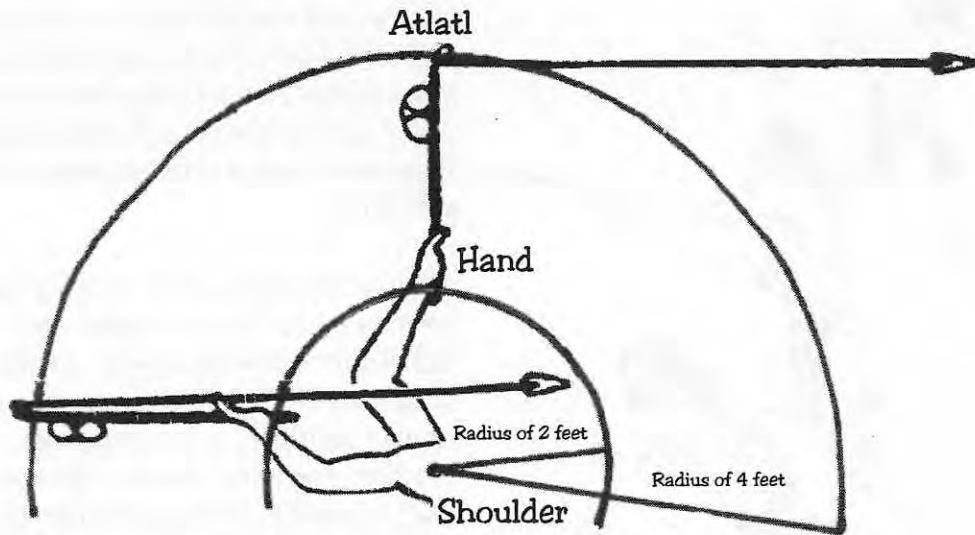

## Atlatl Antics

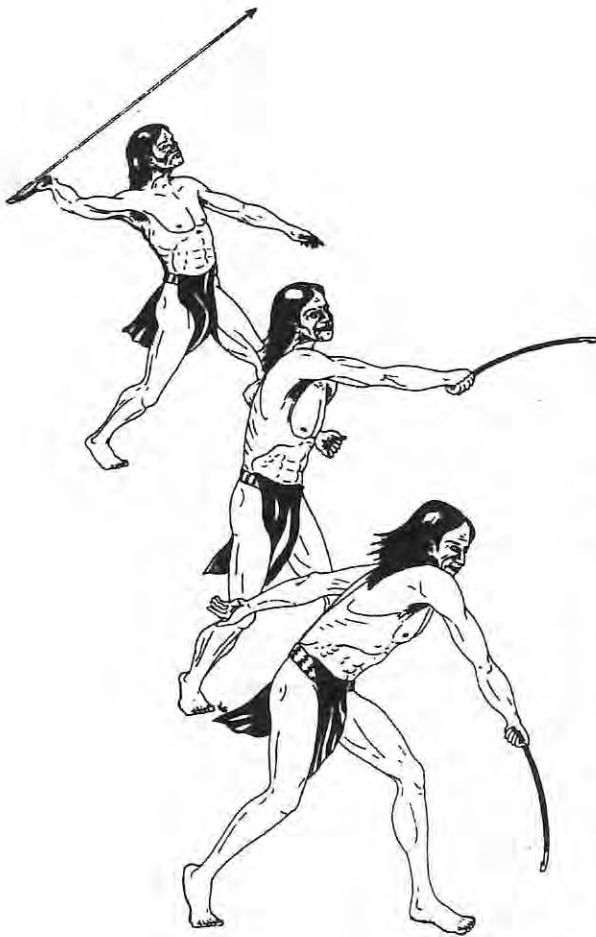

drawing by Jon Gibson

About 3,500 years ago, the Poverty Point people used a spear thrower called an **atlatl**. The atlatl started being used thousands of years before Poverty Point was even built. It was still used around A.D. 400 when Louisiana Indians began adopting the bow and arrow.

An atlatl helped the hunter throw his spear because it gave him a "longer" throwing arm and greater throwing power. Atlatls have been described as shaped like "oversized crochet needles" because they were about two feet long with a hook at the spear end. The back end of the spear fit into the atlatl. Sometimes an atlatl hook was made of deer antler and attached to the wooden atlatl to hold the spear in place. Stone weights were attached to the middle of the atlatl to add more force to the throwing arm. These are often called bannerstones or atlatl weights.

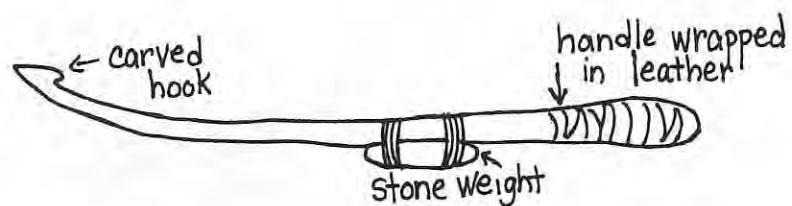

The hunter would hold the spear in place with his thumb and pointer finger, while the other fingers maintained a steady hold

on the atlatl. The spear was thrown by using an overhand motion similar to casting a rod and reel. At just the right time, the hunter would let go of the spear and send it toward its target. One of the trickiest things about using an atlatl is holding onto the atlatl when you let go of the spear.

Complete the following Atlatl Antics activities by using a modern day hunting tool known as a clay target thrower. Modern hunters use this tool to throw clay targets into the air to practice target shooting. See if you can hit the mark and determine why both ancient and modern man invented this kind of tool.

**Step 1:**

Each member of your team will begin the Atlatl Antics by throwing the clay disc as far as possible using only arm power. Use a tape measure to measure and record the distance each team member throws the target. Each team member will have two tries. NOTE: The clay targets are VERY FRAGILE and will break on impact. Plan to spend some time picking up the pieces!

**Throwing Distances Using Arm Power**

Team Member	Throw #1	Throw #2	Average

**Step 2:**

Next each team member will use the thrower to heave the clay target as far as possible. Measure and record these distances as well. Be sure to read the directions telling how to use the clay target thrower. There are different directions given for left and right handed people. You use the clay target thrower like a tennis racket, throwing from the side. This is different from the atlatl because the Indians used it to throw spears from an overhead position. This shouldn't make a difference in your results. The principle of adding arm length to increase the distance and speed of the thrown object is the same with the atlatl and the clay target thrower.

**Throwing Distances Using a Clay Target Thrower Atlatl**

Team member	Throw #1	Throw #2	Average

**Conclusions:**

Add each student's two throws together to get a sum and then divide by two. This will give you an average of each person's efforts for the free arm and atlatl throws. Does the distance change when the clay target thrower is used? Describe your results.

---

---

---

Why did ancient Indians use the atlatl spear thrower? What conclusions can you make based on your experiments with the clay target thrower?

---

---

---

---

**Create a Horizontal Bar Graph to Show Your Results!**

Each student will have two horizontal bars on the graph. The first bar will show how far the student threw the clay target using arm power. The second bar will show the distance thrown using the clay target thrower or atlatl. Color the bars showing arm power with one color and the clay target thrower bars a different color. Label the students' names along the left vertical side of the graph and label the distances thrown along the bottom horizontal axis of the graph.





# The "Do It Yourself" Atlatl

## Independent Project for Students

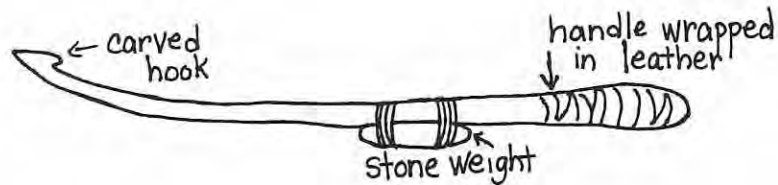

### Subject Areas:

Art, Language Arts, Math, Science, Social Studies

### Objectives:

The student will:

1. Follow directions to build an atlatl and spear similar to those used by prehistoric people.
2. Experiment with balance point, flexibility, atlatl weights, and fletching to determine what variables contribute to the "best" atlatl and spear.

### Time:

About five hours of independent work

### Materials:

River cane or dowel measuring 6 feet long and ½ inch in diameter  
Thick piece of rubber or foam rubber  
2-foot branch of straight or slightly curving hardwood  
Knife for carving wood  
Large rock for the atlatl weight  
Epoxy or wood glue  
Dental tape  
Feathers

### Must Know Info:

**atlatl:** (at' la tel)  
a stick used to hold the end  
of a spear; used to throw  
spears

Some students may express an interest in building their own **atlatl** and spear. These directions are probably best followed at home

under the close supervision of adults as they involve the use of hand tools to construct a realistic prehistoric hunting tool.

About 3,500 years ago, the Poverty Point people used a spear thrower called an **atlatl**. The atlatl started being used thousands of years before Poverty Point was even built. It was still used around A.D. 400 when Louisiana Indians began adopting the bow and arrow.

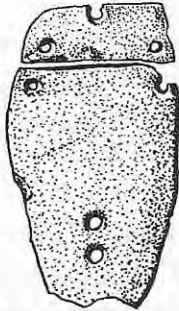

Clarence H. Webb (1982)  
courtesy of LSU Dept. of  
Geography and Anthropology

**bannerstone:**

a stone attached to an atlatl;  
also known as an atlatl  
weight

An atlatl helped the hunter throw his spear because it gave him a "longer" throwing arm and greater throwing speed. Atlatls have been described as shaped like "oversized crochet needles" because they were about two feet long with a hook at the spear end. The back end of the spear fit into the atlatl. Sometimes an atlatl hook was made of deer antler and attached to the wooden atlatl to hold the spear in place. Atlatl weights made from stones were attached to the middle of the atlatl to add more force to the throwing arm. These are also called **bannerstones**.

The hunter would hold the spear in place with his thumb and pointer finger, while the other fingers maintained a steady hold on the atlatl. The spear was thrown by using an overhand motion similar to casting a rod and reel or serving a tennis ball. At just the right time, the hunter would let go of the spear and send it toward its target. One of the trickiest things about using an atlatl is holding onto the atlatl when you let go of the spear.



**fletching:**

feathering, as on an arrow

Some atlatl enthusiasts are experimenting to find the best kind of spear. They think that the most important characteristics of a good spear are its balance point and flexibility. The effectiveness of the spear may also be influenced by the position of the stone weight, which is called an atlatl weight or bannerstone. **Fletching**, the feathers at the end of the spear, may also affect its flight. Students are encouraged to experiment to determine what characteristics make the "best" spear. This would be a really fun science fair experiment.

Caution students that they are building a replica of a prehistoric weapon used to kill animals for dinner and that they need to be careful when practicing with the atlatl. They will need lots of open space with no other people or animals near.

## Procedures:

1. Students should review atlatl information from the *Atlatl Antics* experiment. If this experiment was not completed in class, give students the handout with factual information.
2. Tell students that the hardest part about learning to throw a spear with an atlatl is trying to hold onto the atlatl while releasing the spear. Beginners usually let go of everything! It just takes practice!
3. Remind students that the atlatl is a hunting weapon. They should remember to use the atlatl carefully and not to aim it at people or animals. Atlatls should only be used in open areas where there are NO other living beings.
4. Just for fun! Students can conduct experiments to determine the effects of moving the atlatl weight to different spots on the atlatl. Students could also remove the weight to see if this affects the distance the spear is thrown. They may also alter the balance point of the spear or add fletching to the spear to see the effects. This would make a great science fair project.
5. Another fun activity would be to hold a Student Atlatl Competition for distance and accuracy. There are national competitions in atlatl throwing that your students may want to research on the Internet.

# The "Do It Yourself" Atlatl

## Independent Project for Students

Feeling a little prehistoric? Try these directions to build your own Native American atlatl and spear. Remember that this is an ancient weapon which was used to hunt and kill animals for dinner! Be careful when practicing with your atlatl and do not aim or throw in the direction of living beings! Adult supervision is a must.

The atlatl should be carved from a hardwood. Take a hike to find a straight or slightly curving branch of oak, hickory, or pecan which is about two feet long. If you are lucky, you may find a branch that already has a hook on the end or you may be able to trim an off shooting branch to easily make a hook. If not, you will have to carve one on the end. You could glue the tip of a deer antler on for an atlatl hook. The middle of the atlatl needs to be carved away so that it is flat and lower than the handle and the hook. This leaves room for the spear to fit into the hook and for your fingers to hold the spear. You may wrap your handle with leather to make it easier to hold, or you could just leave the bark on the limb. A smooth handle would be slippery.

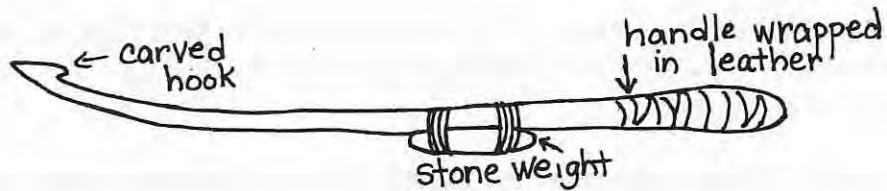

The Native Americans may have used river cane or willow for their spears because they are abundant and grow straight. River cane looks like bamboo and usually grows near water. It is easy to make river cane into a spear because it is hollow. Just cut a slit on the tip end to hold the stone point. The hole at the tail end of the river cane spear will fit into the atlatl hook. If you can't find river cane, a six foot dowel from the lumber store or a willow branch will do nicely. Some archaeologists suggest that the spear's length should be equal to your height. Find a spear length that is

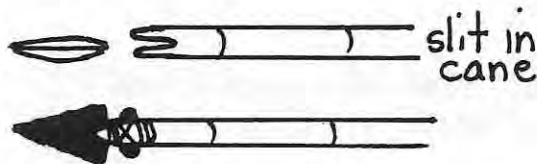

comfortable for you. An adult will need to help you make a hole to fit into the atlatl hook and cut a slit for the stone point.

You may cut a "stone" point from thick rubber or foam rubber. Draw a pattern for your stone point which looks like this one, only larger. Tape the pattern on the rubber and trace around it. With an adult's help, cut the shape out of the rubber. To attach your

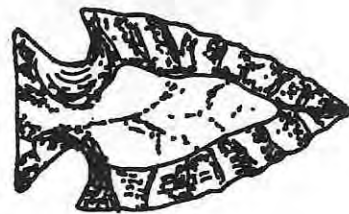

point, carefully cut a slit across the wood at the end of the spear. Slide the point into the slit and glue it with wood glue or epoxy. Now use dental floss to tie the point securely. Native American peoples used sinew from deer to attach stone points to their atlatl spears. Sinew is the long tough tissue which joins the muscle to the bone. Ask a deer hunter to save you some venison sinew and a deer antler. The tip of the antler may be used as an atlatl hook.

Some atlatl enthusiasts are experimenting to find the best kind of spear. They think that the most important characteristics of a good spear are its balance point and flexibility. The balance point of the spear is the location where you can balance the spear on your finger and it stays parallel to the ground. Flexibility means how much the spear will bend without breaking. Try this out to see what you think!

Some experts suggest that the spear needs to be at least six feet long and made from a tree which tapers naturally in thickness, like a willow tree. This would allow the spear to have a stiff front tip end with the first 18 inches too thick to bend. The spear tail should be flexible with most of the bend in the last 18 inches.

If you balance the spear on your finger so that it remains horizontal, the balance point of a good spear should be between 38% to 45% of the way from the tip to the tail. A balance point of about 40% is average.

Find the balance point of your spear! Place the spear on your finger and move it until it is balanced horizontally. Mark the balance point with a pencil. Measure the number of inches from the tip of your spear to the balance point. Now measure the entire length of your spear. Record your measurements below.

The balance point of my spear is \_\_\_\_\_ inches from the tip of the spear.

The entire length of my spear is \_\_\_\_\_.

Divide the balance point measurement by the entire length. Work until your answer is in hundredths. Percent refers to the number of parts out of a hundred, so when your answer is in hundredths, you have figured out the percentage.

My balance point is \_\_\_\_\_ percent of the distance from the tip to the tail of my spear. I hypothesize that my spear will fly \_\_\_\_\_.(terrifically, well, not so well, poorly)





Your spear may need fletching in order to help it fly properly. Fletching refers to feathers which are either glued or tied near the tail of the spear. Fletching can be attached near the tail of the spear or about 12 to 18 inches up the shaft. Experiment to find fletching that works best for your spear and atlatl.

Try attaching a weight in the middle of the atlatl to see if it adds to the distance you can throw your spear. Poverty Point people tied stones to the middle of their atlatls. Archaeologists call these atlatl weights or bannerstones. If you use a rock, be sure to tie it on very carefully so it doesn't fly off and hit you. Move the weight into different positions and determine the effect on your throwing distances.

After you have become an atlatl expert, have a contest in a cleared field or other "people free" area! See who can throw the longest distance or hit targets accurately! Be sure to have adults on hand for supervision!

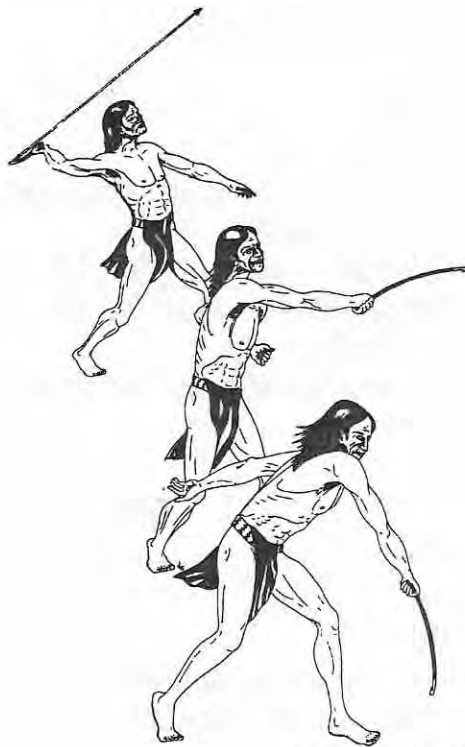

*drawing by Jon Gibson*

# Poverty Point Cooking Balls



## Subject Areas:

Science, Social Studies

## Objectives:

The student will:

1. Discover the types of cooking balls found most frequently at the Poverty Point site.
2. Attempt to replicate these shapes using various techniques.
3. Analyze clues to figure out the origin and purpose of the cooking balls.
4. Discuss specialization and division of labor in the production of cooking balls.

## Time:

One hour

## Materials:

*Poverty Point Cooking Balls* handout

Division of Archaeology Poverty Point suitcase (1-225-342-8170)

or overhead transparency of pictures of cooking balls

Brown play dough or loess soil

Water

Container for soil and water mixture

Paper towels

Geological map of Louisiana

## Must Know Info:

Because so many cooking balls were found at various Poverty Point sites, archaeologists named them Poverty Point Objects or PPOs. In fact, these small objects have become one way for archaeologists to identify a Poverty Point Culture site. Poverty Point people used the cooking balls to cook food in their earth ovens. A pit was dug in the ground and a fire heated the Poverty Point cooking balls. The food was placed in the middle of the PPOs and then the entire "oven" was covered with soil.

**loess:** (lō' is or lōes)  
a fine, yellowish-brown loam deposited by the wind. It consists of tiny mineral particles picked up by the wind from former glaciated areas and brought to the places where they are now found

The PPOs have been referred to as "clay balls," but they are actually made of a kind of soil known as **loess**. Loess soil is only found in certain areas of Louisiana because it is a glacial wind blown deposit. The loess soil was mixed with water to form a "mud pie" mixture which was then shaped with the hands and fingers to form one of several common shapes of cooking balls. Some of the cooking balls have small fingerprints in them. This might indicate that they were made by women or children. The cooking balls were probably dried by the side of the fire before being put into the earth oven. Exposing the cooking balls to fire gives them an orange or reddish appearance caused by oxidation.

Archaeologists have identified shapes of PPOs which are the most frequently found types at Poverty Point. These include two variations of cylindrical grooved, two variations of cross grooved, melon shaped, melon shaped with end grooves, biconical, and biconical grooved. Examples of these are shown on the student handout.

If you use loess soil, you may use these cooking balls in the *Cooking in an Earth Oven* or the *Poverty Point Earth Ovens: Getting the Temperature Right!* activities. If you intend to do these later activities, be sure to weigh the amount of loess/water mixture in each cooking ball. These activities require cooking balls with a wet weight of 60 grams.

## Procedures:

1. Show overhead transparency of pictures of cooking balls or show students an authentic PPO from the Division of Archaeology Poverty Point suitcase exhibit. Call 1-225-342-8170 to schedule this free display for your class.

2. Ask students to hypothesize about the objects' use. Record responses on the board as students brainstorm. Tell students that archaeologists follow this same deductive procedure when they find a new type of artifact. In fact, some archaeologists originally thought that PPOs may have been game pieces.
3. Tell students that some of the objects have small fingerprints imbedded in their surfaces. Ask students what this might indicate.
4. Tell students that PPOs are often found in the remains of fires and hearths at Poverty Point sites. Ask students how this new information changes their ideas about the objects' use. Each added piece of information helps archaeologists and students discover the origin and use of ancient objects.
5. Hand out the *Poverty Point Cooking Balls* sheet and ask students to hypothesize how the PPOs were made. What raw materials were used? Tell students that the PPOs were made from a kind of soil called "loess." Class members may use a Louisiana geological map to determine the soil type in their area and discuss the properties of a physical map.
6. Students will attempt to replicate the production of cooking balls with either loess or play dough. They may mix loess soil and water to make a thick mixture which can be rolled in the palms of the hands or use a golf ball sized piece of play dough. Students should try to make several of the different kinds of cooking balls, sharing their techniques with others in the class. If you plan to use these PPOs in the experiments which follow this activity, each PPO should weigh 60 grams while wet.
7. One or more students may become "cooking ball experts" while other students are still struggling with particular shapes. Suggest that specialization may have occurred in prehistory where people took on jobs at which they excelled. For instance, individuals may have become **flint knappers** or **atlatl** makers and traded these items for cooking balls made by a PPO expert! Children may also have made PPOs because it was a relatively easy job.
8. If the cooking balls are made from loess soil, dry them in a fire or let them air dry. If play dough is used, follow the directions for this material.

**Order a soil map:**  
 Call Wayne Hudnall  
 LSU Dept. of Agronomy  
 1-225-388-1344

**flint knapper:**  
 someone who shapes stone  
 by chipping it with another  
 stone or tool

**atlatl:** (at' la təl)  
 a spear throwing device

# Poverty Point Cooking Balls

Poverty Point cooking balls were made by mixing loess soil and water. Try different ways of rolling your hands to make the cylindrical and melon shaped balls. It may take practice to get a biconical or diamond shape. You can add grooves with your fingers if you would like. Your cooking ball should be a size that will fit comfortably in your hand. You could use your cooking balls in an earth oven to prepare dinner! Good luck!

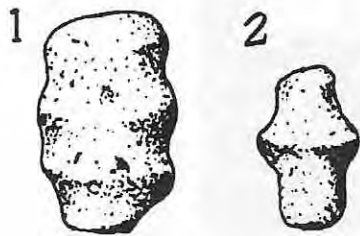

Cylindrical grooved

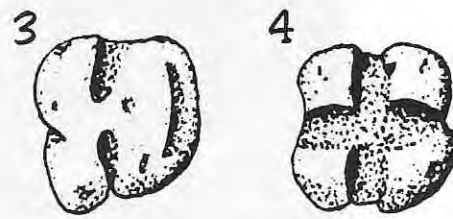

Cross grooved

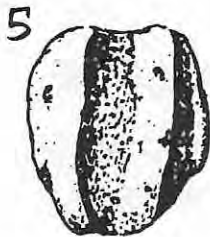

Melon shaped

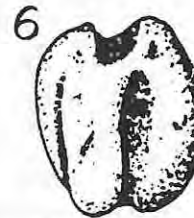

Melon shaped with end grooves

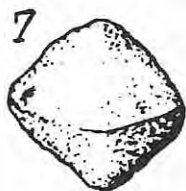

Biconical



Biconical grooved

*Clarence H. Webb (1982)  
courtesy of LSU Dept. of Geography and Anthropology*



# Cooking in an Earth Oven



## Subject Areas:

Language Arts, Math, Science, Social Studies

## Objectives:

The student will:

1. Cook using the earth oven techniques of the Poverty Point people.
2. Analyze the earth oven, compare it with a modern day oven, and evaluate the advantages of cooking this way during the Poverty Point era.
3. Become familiar with foods eaten by Poverty Point people.

## Time:

One hour to dig one earth oven for the whole class and to make cooking balls (You may use the ones from *Poverty Point Cooking Balls* activity if they are made from soil and water.)  
Approximately two hours for cooking and cleaning.

## Materials:

Poverty Point cooking balls  
Aluminum foil  
Bucket of water (for safety)

Shovel  
Firewood  
Oven mitts and tongs

Hot dogs, carrots, sweet potatoes, apples  
*Cooking in an Earth Oven* student handout

### **Must Know Info:**

The Poverty Point people developed a unique way of cooking their food in earth ovens. Archaeologists have discovered earth oven pits at numerous Poverty Point sites. They are usually 12 to 24 inches in diameter and nine to 20 inches deep. The ovens have been found to have from a dozen to over a hundred cooking balls. Sometimes the ovens also contain ash and burned wood fragments.

Some archaeologists have experimented with earth oven cooking. They have found that the cooking balls need to be made and air dried before using them in the earth oven. The cooking balls may be used over and over again in the earth ovens. The experimental cooking balls averaged about 10 "bakings" before they fell apart. Meat, fish, and potatoes were wrapped in leaves and then placed in the bottom of an earth oven pit on top of hot coals. Hot cooking balls were placed all around the food and the earth oven was covered with soil. The food cooked within a two hour time period. Other archaeologists have experimented with using various numbers and kinds of cooking balls to regulate the earth oven's temperatures. This hypothesis can be tested by students in the *Poverty Point Ovens: Getting the Temperature Right!* activity.

Students may use the cooking balls they made in the *Poverty Point Cooking Balls* activity to cook in an earth oven if they were made of soil and water. Do not attempt this activity with cooking balls made from play dough. Suggested foods for student earth oven cooking include "precooked" items such as hot dogs, or carrots, potatoes, and apples, which are delicious and safe when consumed only partially cooked. Be aware of safety concerns and do not let students consume partially cooked meat products from an earth oven.

Of course, the Poverty Point people did not cook hot dogs in their earth ovens. They were primarily hunters and gatherers. The most prominent sources of meat were various kinds of fish such as gar, bowfin, catfish, gaspergou, bass, and sunfish. Venison was the next most important meat source, along with rabbits, squirrels, raccoons, and opossums. Ducks, geese, coot, herons, and turkeys

were also eaten. Plants probably provided most of the Poverty Point people's food, but plants do not preserve well, so it is hard to tell exactly how much of these were eaten. The hard shells of nuts like pecans, hickory nuts, acorns, and walnuts have been found in campfires. Other plant remains which have been found are persimmons, wild grapes, hackberries, and seeds from the honey locust, goosefoot, knotweed, and doveweed. Goosefoot and knotweed are considered pests by today's farmers. A cooperative extension agent or horticultural expert may be able to show students examples of these plants. Do not eat them because they may have been sprayed with an insecticide.

Most other early peoples cooked by heating hot rocks and dropping them into containers of food to be cooked. This was not practical since the Poverty Point people lived in a river delta region where rocks were scarce.

### Procedures:

1. Tell students that the Poverty Point way of cooking differed from other prehistoric cooking methods. Most early people cooked by heating rocks and dropping the hot rocks into containers of the food to be cooked. Ask students why Poverty Point people may have developed a different way to cook. (Few available rocks)
2. We often think of ancient people roasting their meat on open campfires. How might earth ovens have been a better way to cook? (Vegetables don't fall off when done, saves firewood, chef doesn't have to watch constantly)
3. Tell students the kinds of foods which were eaten at Poverty Point. If possible, obtain examples or pictures of these foods to show students.
4. Follow the directions on the *Cooking in an Earth Oven* handout to build an earth oven and cook your dinner. Keep water nearby for emergencies! ADULT SUPERVISION IS A MUST!
5. Create a Venn diagram comparing the parts of a modern day oven to an earth oven. Think about heat sources, insulation, thermostats, and timers. Consider the similarities or differences.

# Cooking in an Earth Oven

Use the Poverty Point cooking balls you made earlier to cook your dinner! Here are directions for cooking the way the Poverty Point people did thousands of years ago.

## Materials:

Adult helpers

Metal rake

Firewood

Tongs

Aluminum foil

Hot dogs, apples, carrots, sweet potatoes, etc.

Cooking balls from *Poverty Point Cooking Balls*  
activity

Shovel

Measuring tape or yard stick

Matches or lighter

Hot pads or oven mitts

Bucket of water (for emergencies)

Kitchen timer or watch

## Directions:

1. Find an empty spot of ground away from buildings, trees, etc. to build your earth oven. Ask the owner for permission to build a fire and cook there. Move grass, leaves, and sticks away from your fire area.
2. Fill a bucket with water and have it standing close by for emergency purposes.
3. Use the ruler to measure and mark 24 inches in the dirt and draw a circle with this diameter. Dig a circular pit in the ground about 18 inches deep. Use your ruler to determine the correct depth. Save the earth from the hole because you will need it to cover the oven.
4. With adult supervision, place the firewood in the pit and start a fire using matches or a lighter.
5. Let the flames die down a little. Ask an adult to use tongs and to place the cooking balls in the middle to get hot. Let the cooking balls heat up.
6. While you are waiting, wrap your food in little packets of aluminum foil to keep it clean and to keep it from burning. Archaeologists say that a cooking fire reaches 1100 degrees Fahrenheit. The Poverty Point people probably used leaves or woven mats made from cat tail leaves to wrap their food. Today we use aluminum foil for the same purpose.

**ADULT SUPERVISION REQUIRED!**

7. When the fire has died down completely, use the rake to move some of the cooking balls to the side. Put the container of food on top of some cooking balls in the middle. Use the tongs to carefully put the remainder of the cooking balls on top of the package of food.
8. Use the rake to cover the pit with the dirt that was dug out of it.
9. Wait and check your dinner to see if it is done. The amount of cooking time will change depending on how many cooking balls you have and the amount of food you are preparing. Make sure that your food is done. It wouldn't be safe to eat something raw.
10. If you want to eat a truly authentic Poverty Point dinner, be sure to eat lots of hickory nuts, pecans, and muscadine grapes.
11. Be certain that **YOUR FIRE IS COMPLETELY OUT** before you leave the area. Pour water on your coals and put the dirt back in the hole. Clean up after yourself so that no one can tell you have been there. Thank the adults who helped with this activity.

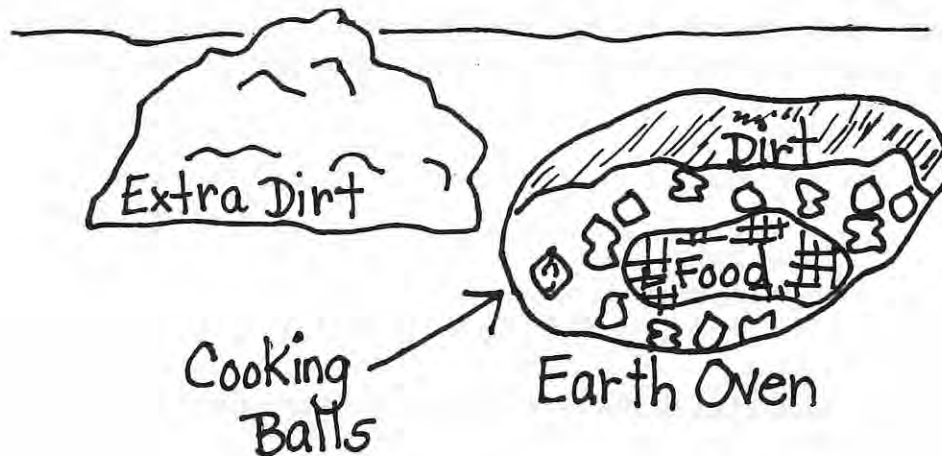



# Poverty Point Ovens: Getting the Temperature Right!



## Subject Areas:

Language Arts, Science, Social Studies, Math

## Objectives:

The student will:

1. Experiment to determine how various shapes of cooking balls retain heat in an earth oven.
2. Gather, record, and analyze data to draw conclusions about the impact the amount of surface area has on heat retention in Poverty Point objects.

## Time:

One hour to make cooking balls (60 gram PPOs from *Poverty Point Cooking Balls* activity may be used)

One hour to set up earth ovens in pots

Two one-hour class periods for experiment and conclusions

## Materials:

Loess soil and water or 60 gram cooking balls made during  
*Poverty Point Cooking Balls* activity  
Soil to fill terra cotta pots  
4 inch diameter terra cotta pot for each student group  
Measuring cups  
Heat safe thermometers  
Tongs for picking up hot cooking balls  
Thin colored markers  
*Poverty Point Cooking Balls* overhead transparency  
Digital watch or watch with minute hand  
Scales  
Tape  
Ruler  
Oven or toaster oven

## Must Know Info:

Earth oven cooking was an innovation created by the Poverty Point people. They made cooking balls by mixing the local soil with water and forming the mud into various shapes. These cooking balls were placed in the bottom of earth oven pits and heated with fire. Food items were probably wrapped in leaves or other material before being surrounded by the hot cooking balls. The earth oven and food were then covered by soil, sealing the oven shut. This cooking method is particular to the Poverty Point Culture.

Experiments have shown that the temperature inside an earth oven is influenced by the number and kind of cooking balls which are used. Experimenters could control how hot the oven got and how long the oven stayed hot by the cooking balls they used. Because of this, archaeologists hypothesize that the cooking balls may have been used as a type of thermostat by Poverty Point people.

The most frequently found cooking ball shapes are identified in the *Poverty Point Cooking Ball* activity. Cooking balls made during that activity may be used to complete this experiment if the mud for each wet cooking ball weighed 60 grams. Archaeologists note that most Poverty Point cooking balls weigh between 50 and 60 grams. Weigh the dried cooking balls and find samples of different kinds which have the same weight. This will insure that the cooking balls have the same amount of material or mass. Because

they have different shapes, each cooking ball will have a different amount of surface area. Students will be testing the hypothesis that the differing amounts of surface area account for the differences in heat retention. Line graphs of student data will show the rate at which different cooking balls release their heat energy. It is helpful to graph each cooking ball type in a different color for clarity. There is no "correct answer" for this activity. Students are using the scientific process just like archaeologists.

Divide your class into groups of three students each. Each group will work together to build one earth oven terra cotta pot and test one kind of cooking ball. Group members will work as a timer, a recorder, and a thermometer reader during data collection.

Because this activity involves very HOT cooking balls, you will want to supervise students closely! It may be advisable to work with a limited number of groups at one time when adding the hot cooking balls to the earth oven pots.

### **Procedures:**

1. Show students the transparency of Poverty Point cooking balls from *Poverty Point Cooking Balls* activity. Brainstorm ideas about why so many different shapes were made. Tell students that some archaeologists wonder if the Poverty Point people used the different shapes as thermostats in the same way that we use our microwave oven power levels. Each group should pick a different shape to test.
2. Go over *Poverty Point Ovens: Getting the Temperature Right!* handout with students prior to beginning the experiment. If you are using cooking balls constructed during the *Poverty Point Cooking Balls* activity, it is important that you find cooking balls of different shapes which have the same weight for this experiment. If you make the balls as a part of this activity, measure the mud mixture so that each ball has a "wet" weight of 60 grams. Weigh the balls again after they dry and compare the differences. Use different shapes of cooking balls with identical weights for this activity.
3. Proceed with steps in the handout to make the cooking balls and to set up the terra cotta pot earth ovens.

4. Heat the cooking balls in an oven or toaster oven on high for 30 minutes prior to continuing the experiment. An adult must pick up the cooking balls with tongs and place each one in a different group's earth oven. They will be very **hot!** You may want to heat several cooking balls at once in order to start several groups at the same time.
5. Students will immediately cover the hot cooking ball with dirt and record a beginning temperature for the earth oven. Students should read and record temperature data every minute after the cooking ball has been put into the oven for 30 minutes or as long as possible.
6. After each group has conducted the experiment, give groups an opportunity to share their data with the rest of the class. Each group will make a line graph showing their cooking ball data. Make a whole class line graph showing the results for all of the earth ovens. Students will draw conclusions from this graph about which cooking balls release heat very quickly or retain it over time.
7. Students will reach conclusions about which kind of cooking ball they would want to use to get a beginning high temperature in an earth oven or which kind of ball they might use to keep the oven hot over a longer period of time. Perceptive students will start hypothesizing about combinations of different kinds of cooking balls.

# Poverty Point Ovens: Getting the Temperature Right!

The people of the Poverty Point culture made cooking balls in many different shapes and designs. Archaeologists have identified eight major types of cooking balls found at Poverty Point, as well as lots of other shapes and designs. Why would people make all of these different shaped objects to be used for the basic task of cooking in earthen ovens?

Some archaeologists have suggested that the Poverty Point people used their earth ovens much as we use our microwave ovens today. Just as we change the power level on our microwaves from defrost to full power, Poverty Point people may have changed the number and shape of the cooking balls to control the amount of heat used to cook their food.

This experiment will let you cook up some scientific results to “taste test” this hypothesis! Get ready for some really HOT stuff!

## **Question:**

Does the shape of a cooking ball influence the way it gives off heat in an earth oven?

## **Materials:**

Loess soil and water or cooking balls made during <i>Poverty Point Cooking Balls</i> activity	
Soil to fill terra cotta pot	Scales
4 inch diameter terra cotta pot for each student group	Measuring cups
Heat safe thermometers	Tape
Tongs for picking up hot cooking balls	Ruler
Thin colored markers	Oven or toaster oven
<i>Poverty Point Cooking Balls</i> overhead transparency	
Digital watch or watch with minute hand	

## **Directions:**

1. Look at the *Poverty Point Cooking Balls* transparency and choose one type of cooking ball for your group to make. Each group should choose a shape which has a different amount of surface area. Surface area is the amount of the cooking ball’s outside layer that is exposed to air.

Our group will experiment with \_\_\_\_\_ shape of cooking balls.



**ADULT SUPERVISION REQUIRED!**

2. Add water to the soil until you have a thick "mud" mixture which can be rolled into balls. Use the scales to measure out 60 grams of mud for making each cooking ball. Each person in your group should make one cooking ball. Check your finished cooking balls by weighing them on the scales. Most cooking balls found by archaeologists weigh between 50 and 60 grams. *(If your class is using the cooking balls that you made in the Poverty Point Cooking Ball activity, skip this step.)*

3. Let the cooking balls dry and then weigh them again. What differences do you find in weight loss? Record your cooking balls' weights below.

4. Each group will write all of their cooking ball weights on the chalkboard. Look for a weight which all of the shapes have in common. For example, if each of the different shapes has a ball which weighs 57 grams, then this would be a good weight for everyone to use in the experiment.

Our class has decided to use cooking balls which weigh \_\_\_\_\_ grams for this experiment.

5. Use the terra cotta flower pot to make your earth oven. Measure the inside of the pot from the top to the bottom with a ruler. Make a dot with a marker halfway up the side of the pot. Add dirt to the pot so that it is filled up to your dot.

6. Place the heat-safe thermometer in the pot so that the tip touches the dirt. Tape your thermometer in a vertical position along the inside of the pot so that it will not move.

7. Look carefully at all of the different shapes of Poverty Point cooking balls to be tested. Rank them in order from the shape with the MOST surface area to the shape with the LEAST surface area. Remember that surface area is the amount of the cooking ball's outside layer which is exposed to air.

MOST SURFACE AREA:

---

---

---

LEAST SURFACE AREA:

---

**ADULT SUPERVISION REQUIRED!**

8. What is your "best guess" about what will happen in the experiment?

Which ball do you think will give off heat the fastest? \_\_\_\_\_

Which oven will stay the hottest for the longest amount of time? \_\_\_\_\_

How is the amount of surface area related to heat retention? \_\_\_\_\_

\_\_\_\_\_

9. Draw a simple sketch of the type of your group's cooking ball above the Oven column on the Data Sheet and label it.

10. Your group will need one member to measure the temperature on the thermometer, one member to record the data on the Data Sheet, and another member to be the Time Keeper and announce when each minute has passed. Write your job assignments below:

Thermometer Reader: \_\_\_\_\_

Data Recorder: \_\_\_\_\_

Time Keeper: \_\_\_\_\_

11. YOU WILL NEED AN ADULT'S HELP ON THIS STEP! Heat the cooking ball in a hot oven or toaster oven for 30 minutes. Ask the adult to use the tongs to pick up the cooking ball and place it in the middle of the dirt in the earth oven pot.

12. Quickly add soil to the terra cotta "earth oven" until the pot is full. Read the thermometer for the earth oven and record it on your data sheet. Wait one minute and check the temperature of the pot again. Keep checking and recording the temperature of the earth oven every minute. Do this for about 30 minutes if possible.

**ADULT SUPERVISION REQUIRED!**

### Data Sheet

Draw a picture of the shape cooking ball found in your earth oven. Write the name of this type below. You may record your observations during the experiment in the last column.

Type \_\_\_\_\_

<b>Time</b>	<b>Oven Temperature</b>	<b>Observations during Experiment</b>
1 minute =		
2 min. =		
3 min. =		
4 min. =		
5 min. =		
6 min. =		
7 min. =		
8 min. =		
9 min. =		
10 min. =		
11 min. =		
12 min. =		
13 min. =		
14 min. =		
15 min. =		
16 min. =		
17 min. =		

**ADULT SUPERVISION REQUIRED!**

<b>Time</b>	<b>Oven Temperature</b>	<b>Observations during Experiment</b>
18 min. =		
19 min. =		
20 min. =		
21 min. =		
22 min. =		
23 min. =		
24 min. =		
25 min. =		
26 min. =		
27 min. =		
28 min. =		
29 min. =		
30 min. =		

**Line Graph:**

Create a line graph to show your data. You will need to plot the data by making little dots with a colored pencil which show the temperatures and times. The temperatures should be written along the left vertical axis of the graph. The times you recorded data are written along the bottom horizontal axis of the graph as the number of minutes. When you finish, use a ruler to connect the dots. Showing your data in this way may help you see some interesting results. Work with other students in your class to create a class graph showing the results for all the earth ovens. Then answer the results and conclusions questions below.

**Results:**

Which oven reached the highest temperature? \_\_\_\_\_

Which oven kept its heat the longest? \_\_\_\_\_

**ADULT SUPERVISION REQUIRED!**

**Conclusions:**

If you wanted to cook something quickly, what shape balls would you put in the earth oven? \_\_\_\_\_

If you wanted to get a high temperature in your oven and keep it hot for a long time, what kinds of cooking balls would you put in your oven?

---

---

What is the effect of adding earth on top of the cooking balls and the food? What do you think would happen if you didn't cover the balls with dirt?

---

---

Is there any connection between the amount of surface area that a cooking ball has and the way that it gives off heat in the earth oven? If so, what is it?

---

---

---





# Prehistoric Pump Drills



## Subject Areas:

Math, Science, Social Studies

## Objective:

The student will:

1. Construct a prehistoric tool capable of drilling a hole in wood or stone.

## Time:

One hour to assemble if an adult has drilled the pieces ahead of time

## Materials:

16 inch length of 1 inch diameter dowel  
24 inch length of 5/8 inch diameter dowel  
12 inch length of 5/8 inch diameter dowel  
Stone "arrowhead" point from a rock shop  
Piece of river cane  
Two rocks or weights  
Heavy nylon string

Dental floss  
Safety goggles  
Electric drill  
Saw  
Epoxy or wood glue

## Must Know Info:

The directions for this drill were adapted from a diagram at the Poverty Point State Commemorative Area.

### **microlith:**

small stone tool that is usually at least twice as long as it is wide and has parallel sides; used as a perforator for making holes or as a blade for scraping and cutting

### **plummet:**

fishing weight or bola in teardrop shape, ground from heavy lumps of iron ore

### **bannerstone:**

stone weight attached to an atlatl; also known as an atlatl weight

### **steatite:** (stē' ə tīt)

a soft rock that has a soapy feel; also called soapstone

Archaeologists think that the pump drill may have been used by Native Americans to start fires. The pump drill produces heat through friction as it spins and this could have been used to ignite tinder or kindling. The pump drill also does a very good job of drilling, both in wood and stone! Poverty Point people were noted for their stone tools, especially the small **microliths** used for drilling, punching, and other work. The pump drill could have been used to make holes in beads, pendants, **plummet**s, and **bannerstones**. Broken bowls made from **steatite** were mended by drilling holes in the pieces and then tying them back together.

If you attach a one-inch-long "microlith-like" stone point to the end of a pump drill, you can drill a nice hole in very little time. Look at rock shops for replica stone "arrowheads" to use as microliths.

The pump drill may be constructed to drill through either wood or stone. If you want students to drill in wood, attach a stone point as a drill bit. A one-inch piece of river cane is a good bit for drilling a hole in stone, but you must sprinkle sand under the drill. The river cane is hollow and will slide right over the end of the 24 inch dowel. Choose a closely fitting piece so that the river cane doesn't slide around as the pump drill moves. Have extra drill bits handy because river cane splits when it dries.

To work the drill, twirl the horizontal hand piece in one direction to twist up the string. This should cause the hand piece to be pulled up toward the top of the drill. Put your hands on either end of the horizontal hand piece and gently push down. This will start the pump drill spinning! When it has spun all the way in one direction, it will reverse and spin in the opposite direction. As long

as you gently move your hands up and down, the pump drill will continue to drill.

Students should be careful NOT to push down too hard on the crosspiece which operates the drill. A gentle up and down motion on the crosspiece is sufficient. After the drill's momentum is established, it will almost operate on its own. If students try to push down really hard or try to make the drill spin very fast, the string holding things together may break. Pieces of drill flying through the air create a dangerous situation! Be careful. Students should wear safety goggles to guard against injury.

Students are fascinated by this hand-operated tool. They really enjoy drilling little holes all over the place. Be sure to set up drilling guidelines and to provide a large flat piece of wood for them.

### Procedures:

1. Gather all materials. Cut wood to the appropriate lengths. Drill holes in the dowels.
2. Review directions on *Prehistoric Pump Drills* handout. Follow directions to attach the stone point and to put the drill pieces together.
3. Students can experiment with using the drill without the weights on the crosspiece. Have them hypothesize what will happen before experimenting. What happens? Why? If students are not familiar with momentum, explain that this is the force which keeps the drill turning. Without the weights, the amount of momentum is reduced.
4. Students will probably comment on the similarity between the prehistoric pump drill and a modern electric drill. Have students create a Venn diagram to compare the two tools.

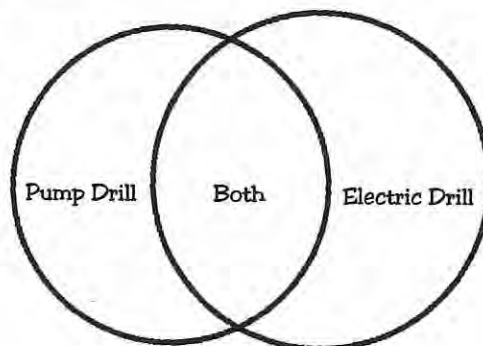

5. Students may want to conduct research to find out about other historic drills and the cultures which used them. How were drills operated before electricity? What kinds of drills are used today, especially oil drills in Louisiana?

6. What other modern technologies are descended from ancient times? Create a classroom chart which shows the tools of prehistoric and modern technology. As students discover more about mound building cultures, they will be able to fill in the chart with the kinds of tools and compare the various technologies.



# Prehistoric Pump Drills

Archaeologists think that the pump drill may have been used by Native Americans to start fires. The pump drill produces heat from friction as it spins. This could have been used to ignite tinder or kindling.

The pump drill also does a very good job of drilling, both in wood and stone! Poverty Point people were noted for their stone tools, especially the small microliths used for drilling, punching, and other work. The pump drill could have been used to make holes in beads, pendants, plummets, and bannerstones. Broken bowls made from steatite were mended by drilling holes in the pieces and then tying them back together.



Microlith



Plummet

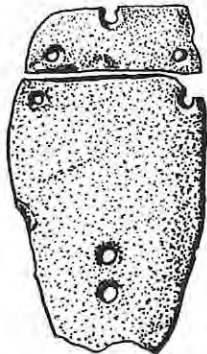

Bannerstone

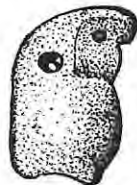

Owl Bead

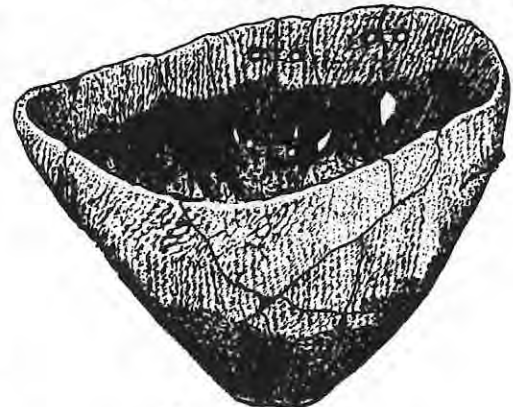

Steatite Bowl

*Clarence H. Webb (1982)  
courtesy of LSU Dept. of Geography and Anthropology*

If you attach a one-inch-long microlith-like stone point to the end of a pump drill, you can drill a nice hole in very little time. If you want to drill a hole in stone, use a piece of river cane for a drill bit. Sprinkle some sand where you are drilling to serve as grit between the stone and the drill.

To work the drill, twirl the horizontal hand piece in one direction to twist up the string. This should cause the hand piece to be pulled up toward the top of the drill. Put your hands on either end of the horizontal hand piece and gently push down. This will start the pump drill spinning! When it has spun all the way in one direction, it will reverse and spin in the opposite direction. As long as you gently move your hands up and down, the pump drill will continue to drill.

Be careful not to push down too hard on the hand piece which operates the drill. A gentle up and down motion is sufficient. After the drill's momentum is established, it will almost operate on its own. If you try to push down really hard or try to make the drill spin very fast, the string

holding things together may break. Pieces of drill flying through the air create a dangerous situation! Pump drills are fun to make and to use! Remember to be careful with your prehistoric pump drill and to always drill on scrap wood. Wear safety goggles to protect your eyes!

### Materials:

16 inch length of 1 inch diameter dowel for the hand piece

24 inch length of 5/8 inch diameter  
dowel for the upright piece

12 inch length of 5/8 inch diameter  
dowel for the crosspiece

Heavy nylon string

Dental floss

Two rocks that are the same weight  
and size or several large heavy  
washers with holes in the  
middle

Microlith stone point (get from rock  
shop)

Epoxy or wood glue

Electric drill

Safety goggles

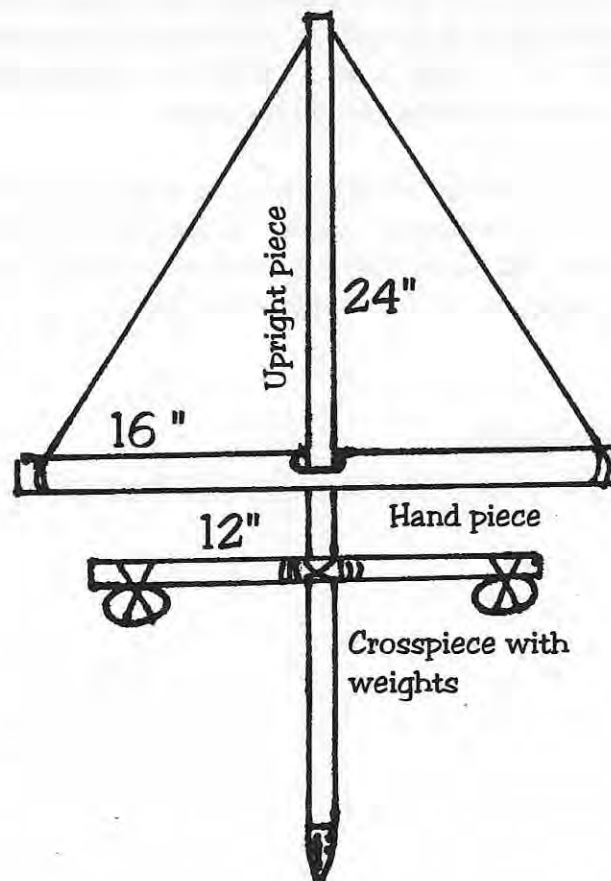

### Directions:

1. Drill a 3/4 inch round hole through the middle of the 16 inch hand piece as shown in the picture. The 24 inch upright piece will need to fit through the hole easily and be able to turn without sticking.

2. Drill a hole for the stone point in the bottom of the 24 inch upright piece. Insert the stone point into the hole and epoxy it into place.

3. Drill a horizontal hole through the top of the 24 inch upright piece so that a string can pass easily through it. Drill small holes through both sides of the 16 inch hand piece so the string will pass through both ends.

4. Put the 24 inch upright through the hole drilled in the 16 inch hand piece. Tie the string to one end of the 16 inch hand piece, run the string through the horizontal hole in the 24 inch

upright and then tie it through the other hole in the 16 inch hand piece. The sideways hand piece should hang freely, a little more than halfway down the drill.

5. Find the middle of the 12 inch crosspiece. This will need to be attached at right angles to the upright piece. Carve out one side of the 12 inch crosspiece so that it that it will fit snugly against the upright.

6. Tie the crosspiece onto the upright piece so that it is about three inches below the hand piece and at right angles to the upright. Glue the two pieces of wood together with wood glue. Then tie dental floss or string in a cross pattern to make sure the joint stays in place. This also looks like the sinew the Indians would have used.

7. Make your weights on the crosspiece by securing a weight to each end of the dowel. You may use stones or an equal number of large washers on each side. These will provide weight to give the drill the momentum it needs to stay in motion. Be sure these are attached securely so that they don't fly off in the middle of drilling!

### **Just for Fun!**

Try using the drill without the weights on the crosspiece! What happens? Why?

# Perplexing Poverty Point Figurines

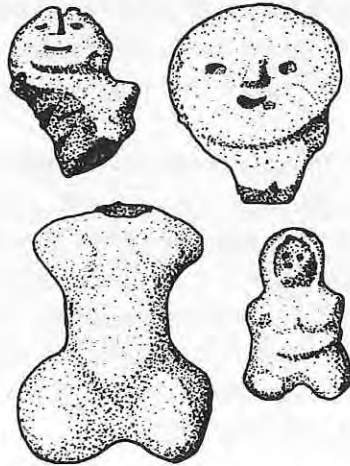

Clarence H. Webb (1982)  
courtesy of LSU Dept. of Geography and Anthropology

## Subject Areas:

Art, Language Arts, Social Studies

## Objectives:

The student will:

1. Create a fictional story explaining the mystery of a headless Poverty Point figurine.
2. Incorporate the elements of plot, character traits, and setting into a literary work.
3. Use self-hardening pottery clay to depict the figurine from the story.

## Time:

Two one-hour class sessions

## Materials:

Division of Archaeology Poverty Point suitcase (1-225-342-8170)  
Overhead transparency of *Perplexing Poverty Point Figurines*  
*Perplexing Poverty Point Figurines* handout  
Self-hardening pottery clay

## Must Know Info:

Archaeologists at Poverty Point have found molded clay figurines or fragments in the shapes of women. In a sample of 133 pieces,

there were 10 heads and 107 torsos, but only 16 whole figurines. Because so many heads are missing, archaeologists hypothesize that the heads may have been broken off intentionally, possibly for some religious or sacred reason. Most of the figurines are from one to 2.5 inches tall and from one to two inches wide.

The figurines are mostly of seated or kneeling women, some of whom appear to be pregnant. Legs and feet were not included on the figurines although some figurines have leg shapes which end before the knees. Arms are usually not shown, but are sometimes indicated by lines or markings. The figurines do not have hands or ears. The heads have eyes and mouths which were possibly carved with a fingernail or a stick. Some of the heads even have lines to show hair on the head.

### **Procedures:**

1. The purpose of the clay figurines is one of the many questions which archaeologists are attempting to answer. Read the first paragraph of the handout aloud to provide students with background information about the figurines.
2. Show *Perplexing Poverty Point Figurines* overhead transparency or the figurine from the Division of Archaeology suitcase.
3. Challenge students to brainstorm reasons why the figurines do not have their heads. Record student responses on the board or overhead. After a few minutes, encourage students to continue brainstorming individually. Remind students that the most original ideas are usually not the first ones generated during brainstorming.
4. After students have generated a list of ideas, encourage them to choose their favorite one to write a story. Now that they have created why the clay figurine was decapitated, a cause and effect relationship can be developed.
5. Instruct students to create a main character and supporting characters. Details about the character's appearance, personality, and feelings will make the character seem more real.
6. This is an excellent time for a mini-lesson on character traits. Present students with examples of character traits like loyalty,



honesty, mischievousness, etc. by either showing them a list of character traits or generating them in class. Instruct students to pick character traits which go along best with their idea of how the figurine became headless.

7. Students will create a character map by picking two or more character traits for the main character and writing these in the spaces on a character map. Under each trait, students need to jot down three things the character will do or say in the story which show this trait. For example, if a character is loyal, what things would she do or say that give evidence of this trait? A character map is an excellent way for students to bring life to their characters. See the example below.

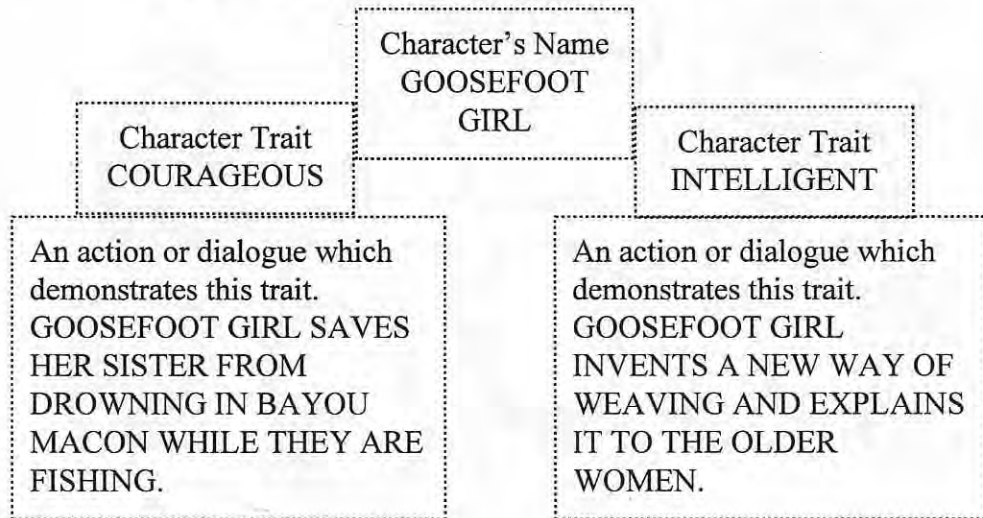

8. Students will complete the setting description and plot sequence on the handout before beginning to write a rough draft. Instruct students to be sure to have a beginning, a middle, and an end to their story. The story can be set up as a problem/solution plot, or a conflict between two characters, etc. Elicit examples of these kinds of plots from students as they begin to brainstorm ideas.

9. Students will write a rough draft on scratch paper and then follow the *Steps in Writing a Story* to check for understanding, spelling, punctuation, and grammar.

10. Students should use self-hardening pottery clay to make figurines to display next to the stories. Be sure they add details like eyes, mouth, hair, etc.

# Perplexing Poverty Point Figurines

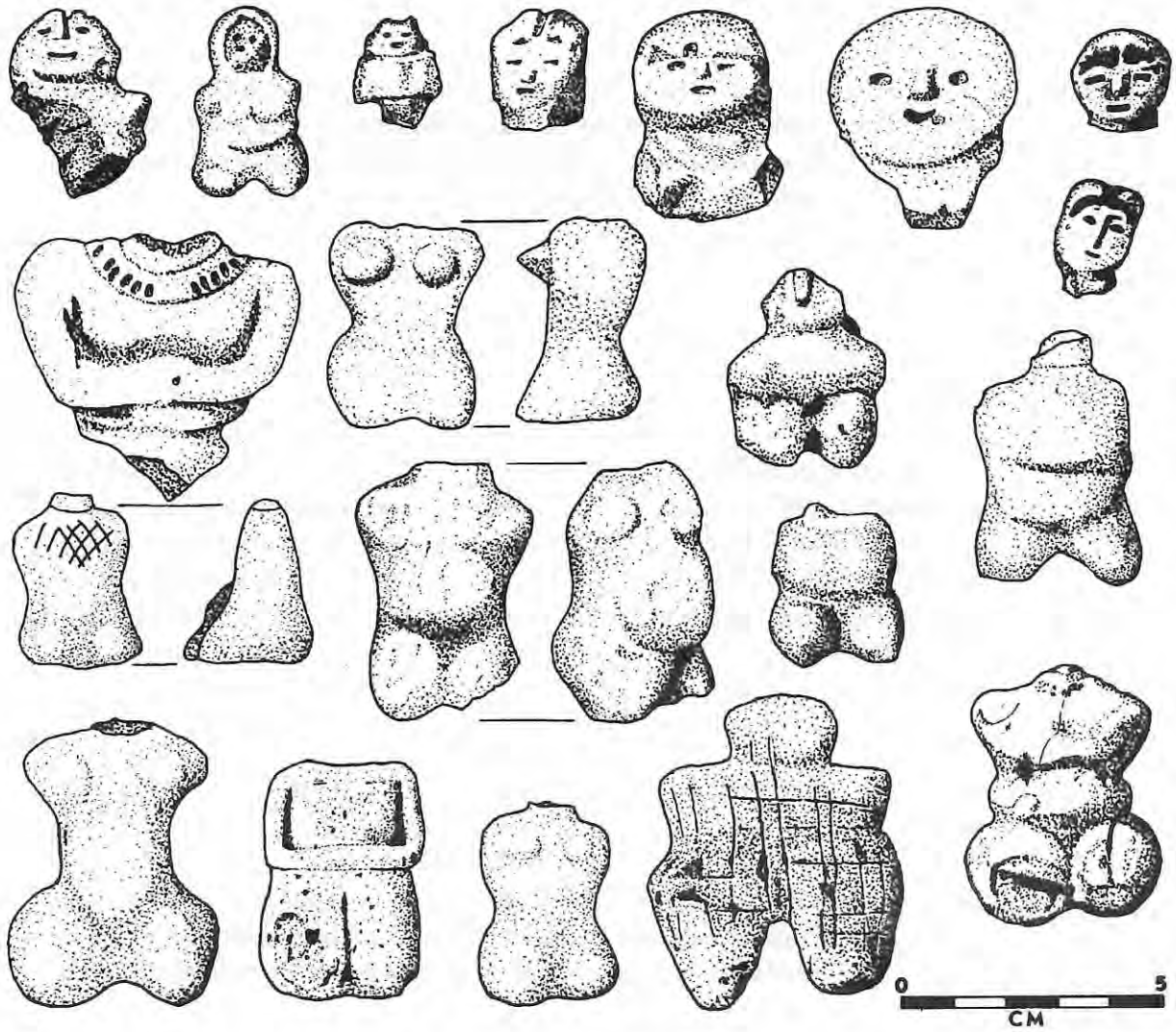

Clarence H. Webb (1982)  
courtesy of LSU Dept. of Geography and Anthropology

# Perplexing Poverty Point Figurines

Archaeologists have found over a hundred clay figurines at the Poverty Point site. They think that these statues may have been sacred or religious objects. The figurines are of seated or kneeling women who have no legs or arms. Some of the women appear to be pregnant. The heads of the figurines are almost always missing and archaeologists think the heads were snapped off on purpose. The figurine heads have details like eyes and mouths carved into them, perhaps with a fingernail or a stick. Some of the heads even have lines to show hair on the head.

Brainstorm and think of reasons for the missing heads!

Imagine what kind of ceremony might have accompanied the snapping off of the figurine's head. What do you think the Poverty Point people believed about the figurines? Why do you think they may have decapitated the figurines?

Write a short story telling about a woman and her sacred figurine. Give the woman a name and describe how she looks and what kind of clothes she wears. Give details about the setting. Where and when does your story take place? What kind of a house does she live in? Tell how and why the figurine was made. Tell how the figurine lost its head. Describe everything that happens and give details.

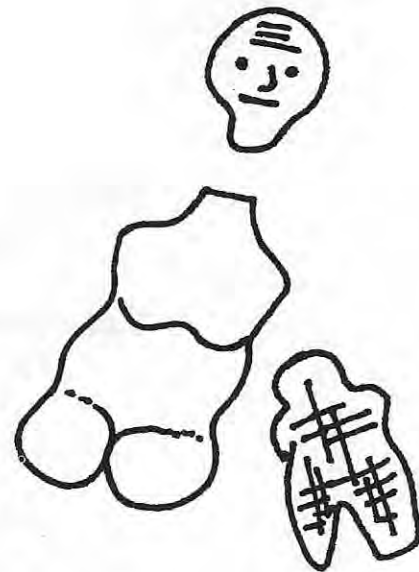

Jot down your ideas before you begin to write:

- Main characters:** Who is in the story?  
**Setting:** Where and when does the story take place?  
**Plot:** What happens in your story? List at least three to five events.

## Steps in Writing a Story

1. Write a rough draft of your story. Find any mistakes and fix them.
2. Have a friend read your story for understanding. Change things that don't make sense.
3. Ask the friend to check your story for misspelled words, capital letters, and grammar.
4. Proof read your story one more time.
5. Write a final draft of your story for the bulletin board or a class book.

After you write your story, make your own clay figurine out of self-hardening pottery clay. Be sure to add details like eyes, mouth, and hair.

# Bird Gods? Fox Man? Long Tail? Too Good to Myth!

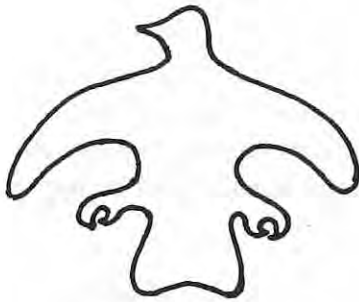

Bird



Fox Man

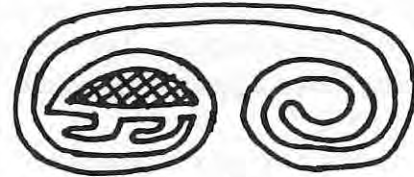

Long Tail

## Subject Areas:

Language Arts, Dramatic Arts, Social Studies

## Objectives:

The student will:

1. Write a creative story using one of the characters identified on Poverty Point artifacts.
2. Include details demonstrating literary aspects of character, setting, and plot in creative writing.
3. Utilize spelling, grammar, and punctuation effectively in the final draft of the story.
4. Collaborate with others to create and act in a dramatization of an original myth.

## Time:

Two hours to write rough draft and final copy of myth  
One hour to write dialogue for play  
Drama group work time will vary

## Materials:

*Bird Gods? Fox Man? Long Tail?* handout  
*Bird Gods? Fox Man? Long Tail?* overhead transparency

## Must Know Info:

**steatite:** (stē' ə tīt)  
a soft rock that has a soapy feel; also called soapstone

**Bird Mound:**  
nickname for Mound A at the Poverty Point State Commemorative Area

**plummet:**  
fishing weight or bola in a teardrop shape, ground from heavy lumps of iron ore

The Poverty Point people carved many unusual and interesting designs on objects such as **steatite** vessels, plummets, and beads. Archaeologists are not certain about the meaning of these designs, but it is fun to imagine about them.

One of the most common images at Poverty Point is that of a bird. Some people call the largest mound at the site the **Bird Mound** because they think it is in the shape of a bird. It may have been a place of ritual or worship because of its location and the earth ramp which is formed by the tail. Beads carved from red jasper are often in the shape of birds, mostly in the shape of little owls with big bellies. Animal claws, bird feet, and talons were also images carved into pendants and beads. Other designs were carved on **plummets** used as weights for fishing. Some archaeologists think that the Fox Man looks like a man with a fox head or hat. Others think that he looks like a horned owl. The Long Tail may be a picture of an opossum. All of the animals represented in Poverty Point engravings are important in the legends of the Southeastern Indians who came later. In later stories, these animals are usually connected with death, witchcraft, early warning, news, and stories of the Indians' beginnings.

## Procedures:

1. Show *Bird Gods? Fox Man? Long Tail?* overhead transparency. Archaeologists have found these images carved on beads, steatite bowls, and plummets found at the site. Plummets are shaped like teardrops and were probably used as fishing weights for nets. The images may have had religious or cultural significance for the Poverty Point people.
2. Distribute *Bird Gods? Fox Man? Long Tail?* handout and read through information with students.
3. Review the characteristics of a myth with students and elicit examples of familiar Greek and Roman myths. Be sure to distinguish between myths, legends, and tall tales.
4. Have students follow directions on handout to create a rough draft and final copy of an original myth.



5. Group students according to the main character in their myths (Bird God, Fox Man, or Long Tail) with three to four students in each group. Students will read their stories aloud and then collaborate to write dialogue for a group dramatization of one of the stories or a combination of plots. Students can devise simple props and costumes using readily available materials.

# Bird Gods? Fox Man? Long Tail? Images from Poverty Point Artifacts

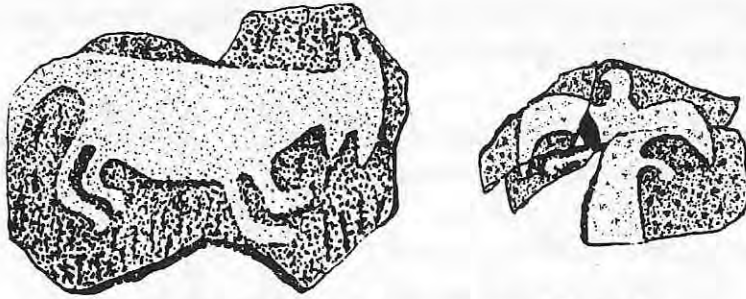

Panther and Bird Images on Steatite



Long Tail Designs  
on Plummets

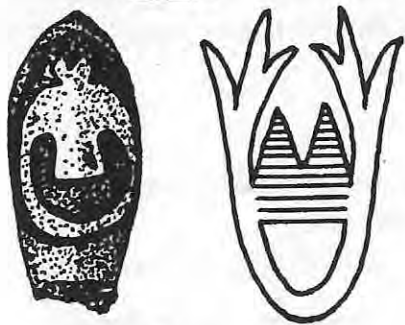
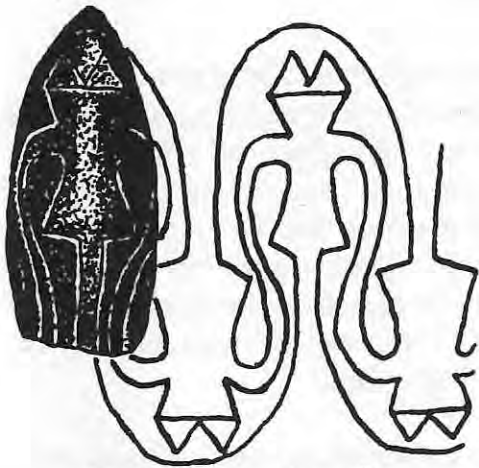

Fox Man Designs  
on Plummets



Bird Images on Beads

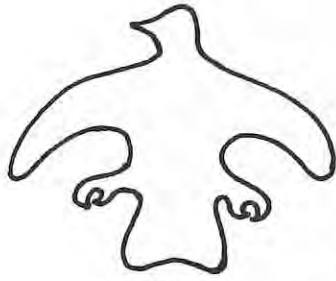

Bird

## Bird Gods? Fox Man? Long Tail? Too Good to Myth!

The Poverty Point people made many unusual and interesting objects. Archaeologists are not certain about the meaning of these objects, but it is fun to imagine about them.

One of the most common images at Poverty Point is that of a bird. The largest mound at the site is called the Bird Mound because some people think that it has a bird shape. It may have been a place of ritual or worship because of its location and the earth ramp which is formed by the tail. Beads carved from red jasper are often in the shape of birds, mostly in the shape of little owls with big bellies. Animal claws, bird feet, and talons were also images carved into pendants and beads.

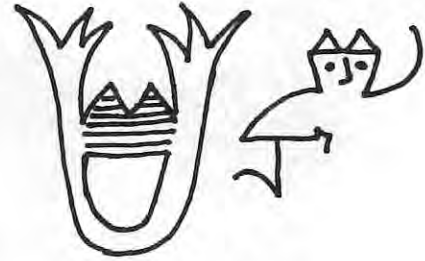

Fox Man

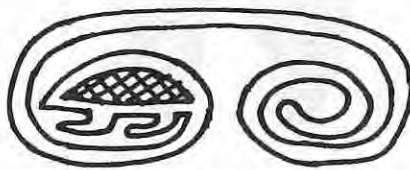

Long Tail

Other designs were carved on plummets used as weights for fishing. These are called the Fox Man and Long Tail designs. Some archaeologists call this design the Fox Man because it looks like a man with a fox head or hat. Others think that it is a horned owl. The Long Tail design may be a picture of an opossum. All of the animals represented in Poverty Point engravings are included in the legends of the Southeastern

Indians who came later. In these stories, the animals are usually connected with death, witchcraft, early warning, news, and stories of the Indians' beginnings.

Pick a character and write a Poverty Point myth. A myth is a story whose main character is a being with super powers. The myth usually explains why something in nature happens, like why we have winter or why the moon changes shape during the month.

Jot down your ideas before you begin to write:

- Main characters:** Who is in the myth? What super powers do they have?  
**Setting:** Where and when does the story take place?  
**Plot:** What happens in your story? List at least three to five events.

### Steps in Writing a Story

1. Write a rough draft of your story. Find any mistakes and fix them.
2. Have a friend read your story for understanding. Change things that don't make sense.
3. Ask the friend to check your story for misspelled words, capital letters, and grammar.
4. Proof read your story one more time.
5. Write a final draft of your story for the bulletin board or a class book.

# Artifacts All Over the Place



## Subject Areas:

Language Arts, Science, Social Studies, Math

## Objectives:

The student will:

1. Analyze life-sized pictures of **artifacts** to decide how they may have been used.
2. Create categories and sort the artifacts into hypothetical groups.
3. Work collaboratively to draw conclusions from the data, write a summary paragraph, and create a bar graph displaying the results of the analysis.
4. Make generalizations about the distribution of artifacts at Poverty Point.

**artifact:**  
any object made or  
modified by people

## Time:

Approximately five one-hour class periods

## Materials:

*Artifacts All Over the Place* handouts  
*Dr. Webb's Findings* handout for each group  
Large map of the Poverty Point site  
Card stock sets of Poverty Point artifacts in large envelopes  
Colored pencils

## Must Know Info:

Completing this simulation will allow students to work with actual archaeological data from Poverty Point. Students will analyze and categorize data and then determine the meaning of their findings through deductive reasoning. Since the students will probably never participate in the excavations at Poverty Point, working with real data and replicas of the artifacts will bring them closer to understanding and appreciating an archaeologist's work. This activity also gives students opportunities to practice writing and graphing skills while working effectively in cooperative groups.

### **Dr. Clarence Webb**

Dr. Webb was a Shreveport pediatrician and archaeologist who conducted research at Poverty Point and other sites. Many of his findings are included in *The Poverty Point Culture*. Dr. Webb has numerous other publications.

This activity is a simulation based on actual data reported by **Dr. Clarence Webb**. The sample sizes in the simulation are based on Dr. Webb's percentages. The following table will show the number of artifacts for each section of Poverty Point. Poverty Point is divided into sections by the aisles which cut through the six concentric rows of ridges. The sections are named North, Northwest, West, Southwest, and South according to their location. The artifacts represented by this simulation were recovered through surface collection rather than site excavation.

Dr. Webb grouped the artifacts into five different categories according to their use. Each section of Poverty Point has handout pages for the artifacts found in that section. Make one photocopy of each artifact page on card stock or heavy paper. This will allow the students to hold the artifacts in their hands and try to figure out what the Poverty Point people did with them. A quick reference guide to the types of artifacts found at Poverty Point is included on page 4 of this book.





Students will work in small groups to analyze and categorize the artifacts in one section. The students will try to determine the uses of the artifacts and generate categories similar to the ones on the table. You may choose to give a small group of students both the Northwest and West sections, since neither contains many artifacts.

In order to help students determine their use, the artifacts are shown in actual size. If a circle has been drawn around two pictures of an artifact, two different views of the same artifact are being shown. Caution students to cut around the circle and to only count the artifact one time when gathering data. Looking at the artifact from both sides will help students imagine how it was used.

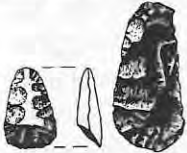

## *Artifacts All Over the Place Simulation Data*

### NUMBER OF ARTIFACTS IN EACH SECTION

KIND OF ARTIFACT	South	South-west	West	North-west	North	Totals
Cooking balls 	22	2	3	2	36	65
Microlith 	16	44	2	2	3	67
Domestic stone tools (hoes, axes) 	12	2	2	3	11	30
Hunting tools 	4	1	2	1	4	12
Clay figurines 	2	1	1	1	2	7
TOTALS	56	50	10	9	56	181

*Clarence H. Webb (1982)*  
courtesy of LSU Dept. of Geography and Anthropology

A handout highlighting Dr. Webb's major findings is included in the student handouts. Give the students the *Dr. Webb's Findings* sheet after they complete their own analysis. Dr. Clarence Webb completed a similar analysis of 18,727 artifacts found at Poverty Point. His results can be found in *The Poverty Point Culture*. Remind students that there are no correct answers at this time because archaeologists are continuing to explore Poverty Point.

Approximately 1% of the Poverty Point site has been excavated by archaeologists at the present time.

During group discussion, students will probably come up with categories similar to Dr. Webb's. This may not be the case, however. Teacher discretion should be used in deciding just how much to "guide" students into Dr. Webb's categories. The students' answers may vary from Dr. Webb's findings! As long as their conclusions are logically drawn from the data, they are following correct scientific method. It is important to keep the focus of this activity on the thinking process rather than the end product!

In addition to creating bar graphs, students could also determine what percentage of stone points, cooking balls, microliths, clay figurines, etc. were found in their section. For instance, out of a total of 56 artifacts found in the South region, 22 of the items were cooking balls. This means that 39% of the items were cooking balls. This compares with the Southwest region where only two cooking balls were found out of a total of 50 artifacts. This is a percentage of 4%. It would seem that the South region did more cooking than the Southwest region. Circle graphs could be created to display this information. Be careful not to compare the number of artifacts in a section with the total number of artifacts found because some regions had been explored more by archaeologists than others. The best way to compare numbers of artifacts is within the same region or to compare the percentage of an artifact found in one region against the percentage found in another region.

### **Procedures:**

1. Introduce the simulation with the scenario presented in the *Artifacts All Over the Place* handout. The class has supposedly received box loads of artifacts from the field archaeologists at Poverty Point. Each small group of students will receive an envelope with one section of Poverty Point artifacts. The West and Northwest sections may be given to the same small group because they have so few artifacts. If your class is large, two small groups may work independently on the same section.
2. Students will follow directions to go through the artifacts, sort them into similar categories according to use, and name the categories they have identified.

3. Each group will share its results by creating a bar graph displaying the artifact data for its section of Poverty Point. Students will analyze the data and draw conclusions about the kinds of activities going on in their section. Group members will collaborate to write a summary paragraph telling the kinds of activities occurring in their section.
4. Students will compare their results with other groups to gain an overall understanding of the activities at the Poverty Point site. For example, where was cooking occurring? Why? Where were microliths being produced? What else was going on in different areas?
5. Be sure to have students compare their graphs with the results reported by Dr. Webb. Hand out the *Dr. Webb's Findings* sheet after students have reported their own results.
6. Students may enjoy making circle graphs to show their results.
7. Student graphs and paragraphs should be displayed on the bulletin board so that students may compare and contrast all results. The overhead transparency on page 15 could be projected onto your bulletin board and traced to create a site map. Place student graphs and paragraphs over the appropriate sections of the map.

# Artifacts All Over the Place

Hundreds of artifacts from the Poverty Point site have just arrived at your lab, the \_\_\_\_\_ Archaeological Center. The artifacts are in cardboard boxes labeled with the location where they were discovered! You and the rest of your archaeological team will need to sort through the specimens, categorize them by type, and see if you can make any sense out of what the field archaeologists are finding. It's an enormous job, but you can do it! Use your extraordinary thinking skills to analyze, hypothesize, and reach conclusions about the data you've received. Follow these steps to organize the artifacts all over the place!

## Step 1:

Your envelope contains artifacts from one of the sections of the Poverty Point site. Find your section on the Poverty Point map.

We are studying the \_\_\_\_\_ section of Poverty Point.

## Step 2:

Cut out your artifacts. If a circle is drawn around two pictures, they are pictures of the same artifact from different sides. Cut on the line around the circle and count it as one artifact! Do not cut them apart!

Look carefully at the pictures of the artifacts to determine any similarities among them. Use what you know about the Poverty Point culture to analyze the uses of the artifacts. Discuss how the artifacts might have been used as you categorize them into several groups. Make up a name for each one of your groups. Record the names and numbers of each kind of artifact below.

Kind of Artifact What was the object used for?	Number Found

### Step 3:

Now you are ready to share your results with the scientific community. Begin by telling the other archaeologists at the \_\_\_\_\_ Archaeological Center about your findings. Share your categories with them and see if their results are similar. Discuss your category names and reach an agreement about which artifact category names to use for the entire study.

### Step 4:

Your group will create the bar graph on the next page to show the kinds of artifacts located in your section of Poverty Point. Write your category names on the left. The number of objects is given along the bottom of the graph. Draw and color the bars on the graph to show your results.

### Step 5:

Use your bar graph to reach some conclusions about the kinds of activities the Poverty Point people did MOST in your area of the settlement. Which activities were done LEAST? Was there a lot of cooking going on? Were hunting tools being made in your area? Were figurines and tools constructed there? Write a paragraph on the Summary of Archaeological Findings page telling about your findings. Be sure to sign your work as Dr. \_\_\_\_\_, because you are a world famous scientist with a Ph.D. in anthropology! Glue your graph and summary next to your section of the Poverty Point map.

### Step 6:

Discuss the finished map with the other archaeologists at the Center. What conclusions can you reach about the uses of different sections of the Poverty Point site? Were some sections used for specific activities? What hypotheses can you make based on the artifacts which were found? Brainstorm your ideas and write a paragraph telling the world about your findings. Publish your results in the *Archaeological Journal for Scientific Research* or the school news letter!

### Step 7:

Compare your results with another archaeologist's work. Dr. Clarence Webb completed a similar analysis of 18,727 artifacts found at Poverty Point. His results can be found in *The Poverty Point Culture*. Ask your teacher for a copy of Dr. Webb's findings at this time. Discuss Dr. Webb's analysis and compare his results with your own. How do your results compare with his?

Approximately 1% of the Poverty Point site has been excavated by archaeologists at the present time. Do you think your results might change as more artifacts are unearthed?



**Summary of Archaeological Findings  
in the \_\_\_\_\_ Section of Poverty Point**

Kind of Artifact	Number of Artifacts Found																								
	0	2	4	6	8	10	12	14	16	18	20	22	24	26	28	30	32	34	36	38	40	42	44	46	

What kind of artifacts did we examine? \_\_\_\_\_

---



---

How many artifacts were there in each group? \_\_\_\_\_

---



---

What are our conclusions? \_\_\_\_\_

---



---



---



---

## Dr. Webb's Findings

Dr. Webb examined and categorized 18,727 artifacts into groups when he completed his study. Here are some of Dr. Webb's major observations and explanations:



Cooking  
Ball

1. Group 1 contained objects used in cooking such as cooking balls. About 90 % of the cooking objects were found in the North and South sections of Poverty Point. Dr. Webb concluded that this indicated a lot of cooking and family habitation in these areas. He also believed that most people lived on the eastern side of the village near the water supplies.



Microlith

2. Group 2 included the tiny stone tools called microliths. These were found most often in the Southwest section. Dr. Webb concluded that the Southwest area was a special area for using this kind of tool. He thought that craftsmen worked there making things from bone, antlers, and wood.



Hoe

3. Group 3 included large stone chopping and cutting tools such as axes, hoes, and hand tools. Each section had some of these tools, showing they were used all over the site.



Stone  
Point

4. Stone spear points were in Group 4. These hunting tools were found in all sections. Dr. Webb called attention to the fact that the hunting tools were fairly evenly distributed, whereas the cooking tools were concentrated in certain areas. He concluded that this meant that different people were doing the two activities.



Figurine

5. Group 5 was made up of beads, pendants, and figurines. Some of these artifacts were found in each section. However, certain special artifacts were found more often in the north area, causing Dr. Webb to conclude that the leaders of Poverty Point lived in this section.

*Clarence H. Webb (1982)  
courtesy of LSU Dept. of  
Geography and Anthropology*

## Dr. Webb's Bar Graph of the Intrasite Distribution of Artifacts at Poverty Point

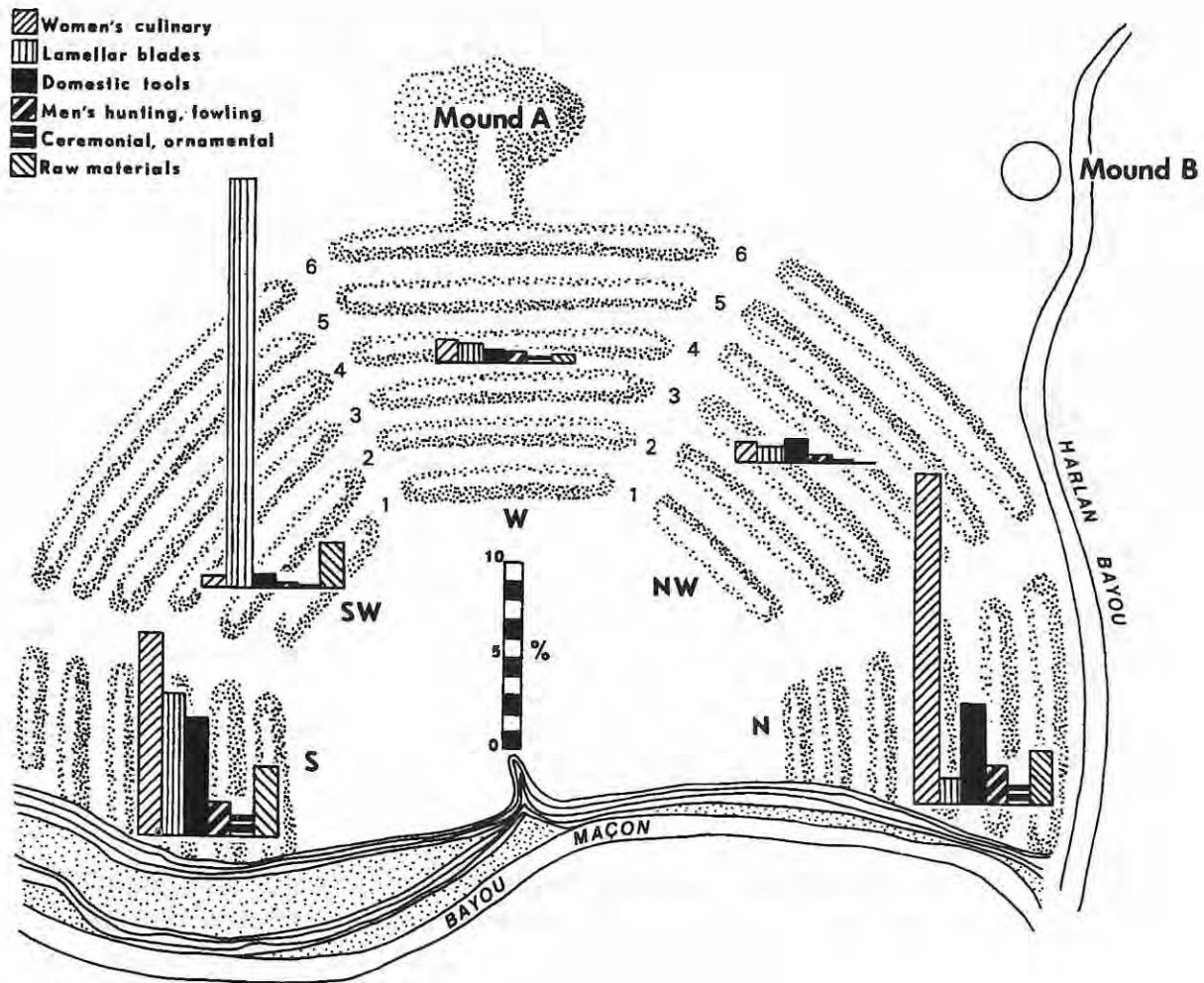

Clarence H. Webb (1982)  
courtesy of LSU Dept. of Geography and Anthropology

# Artifacts from the South Section

*Photocopy one copy on card stock*

*Clarence H. Webb (1982)  
courtesy of LSU Dept. of Geography and Anthropology*

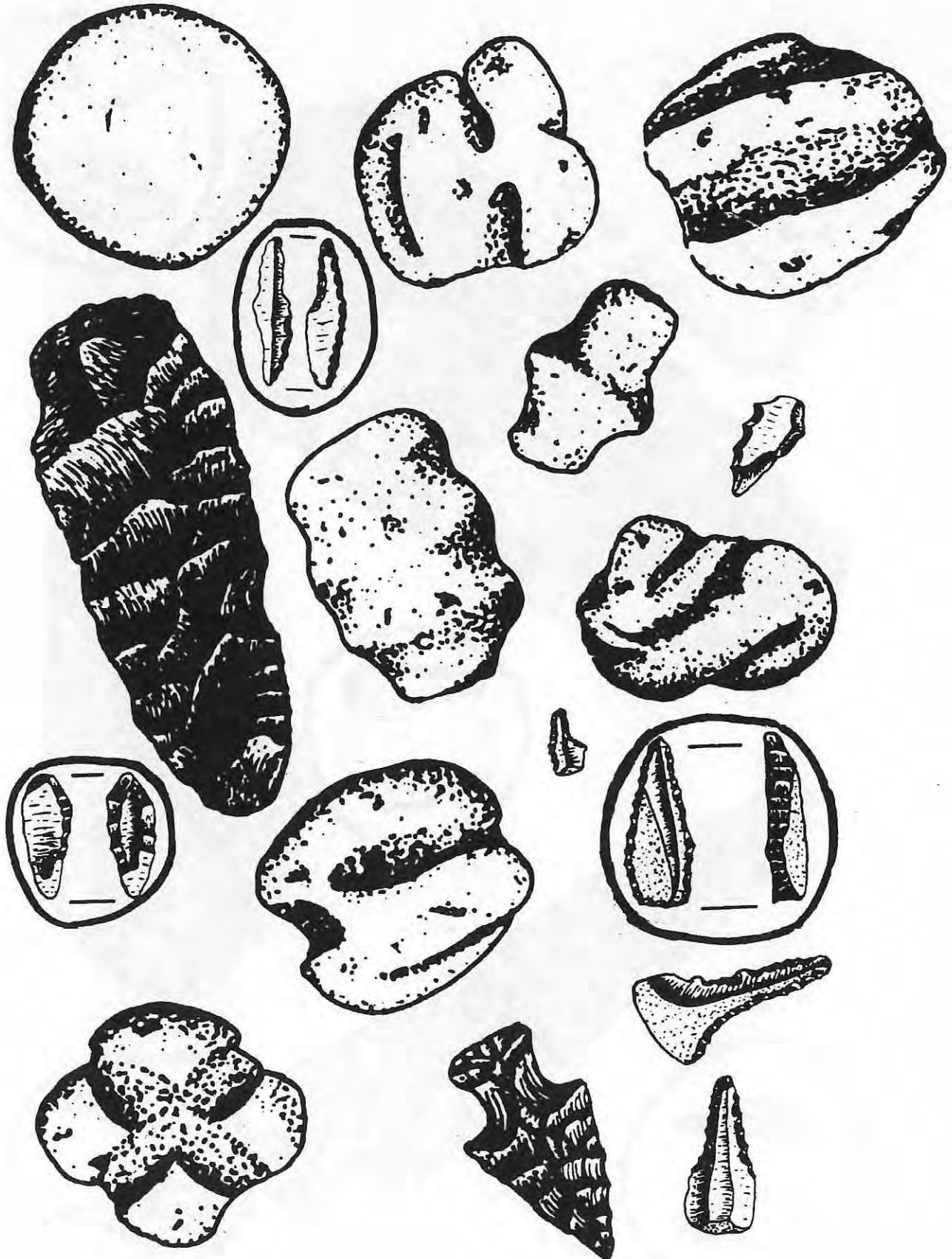

# Artifacts from the South Section

*Photocopy one copy on card stock*

*Clarence H. Webb (1982)*

*courtesy of LSU Dept. of Geography and Anthropology*

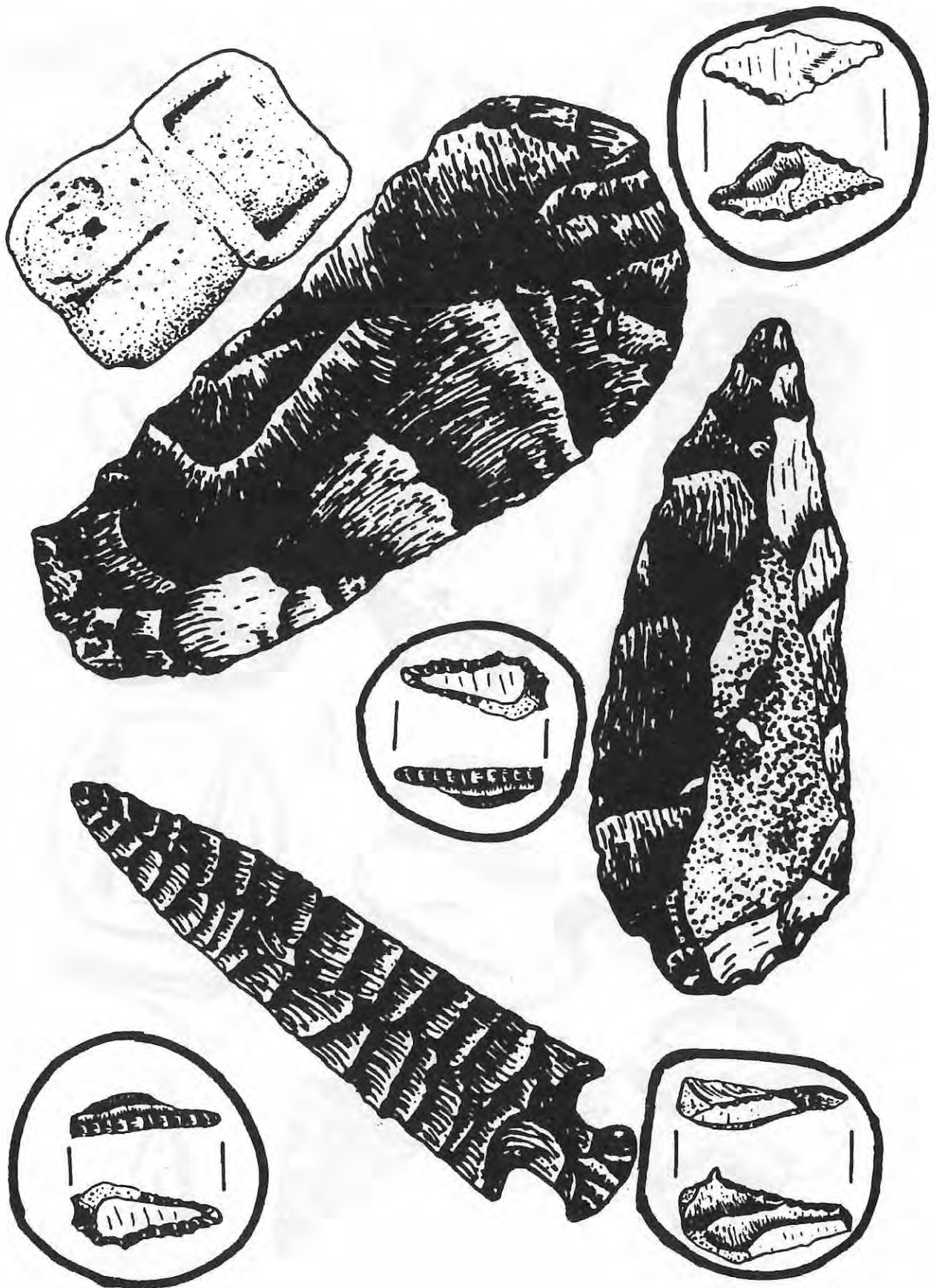



# Artifacts from the South Section

Photocopy one copy on card stock

Clarence H. Webb (1982)

courtesy of LSU Dept. of Geography and Anthropology



# Artifacts from the South Section

Photocopy one copy on card stock

Clarence H. Webb (1982)

courtesy of LSU Dept. of Geography and Anthropology

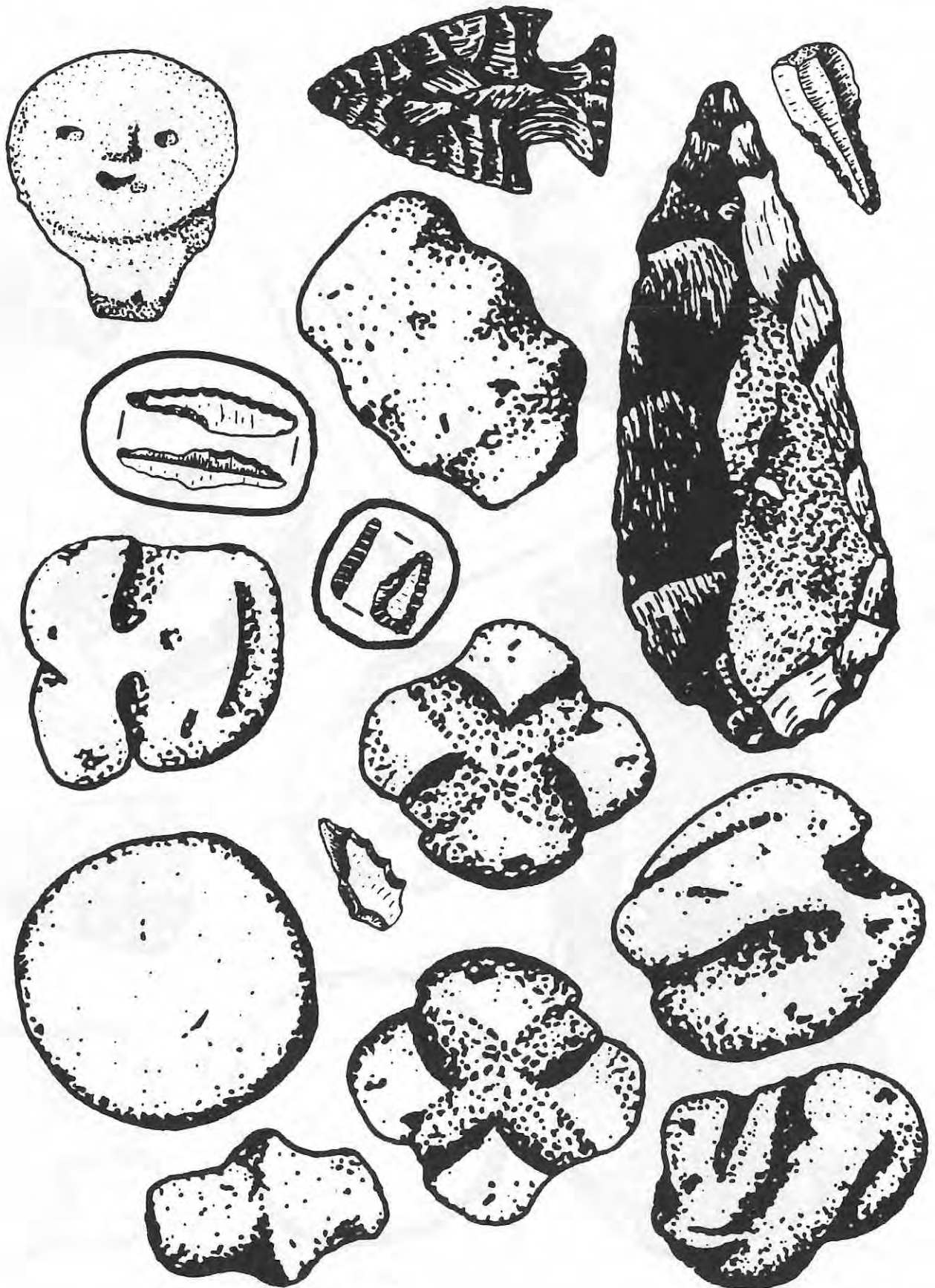

# Artifacts from the South Section

*Photocopy one copy on card stock*

*Clarence H. Webb (1982)*

*courtesy of LSU Dept. of Geography and Anthropology*

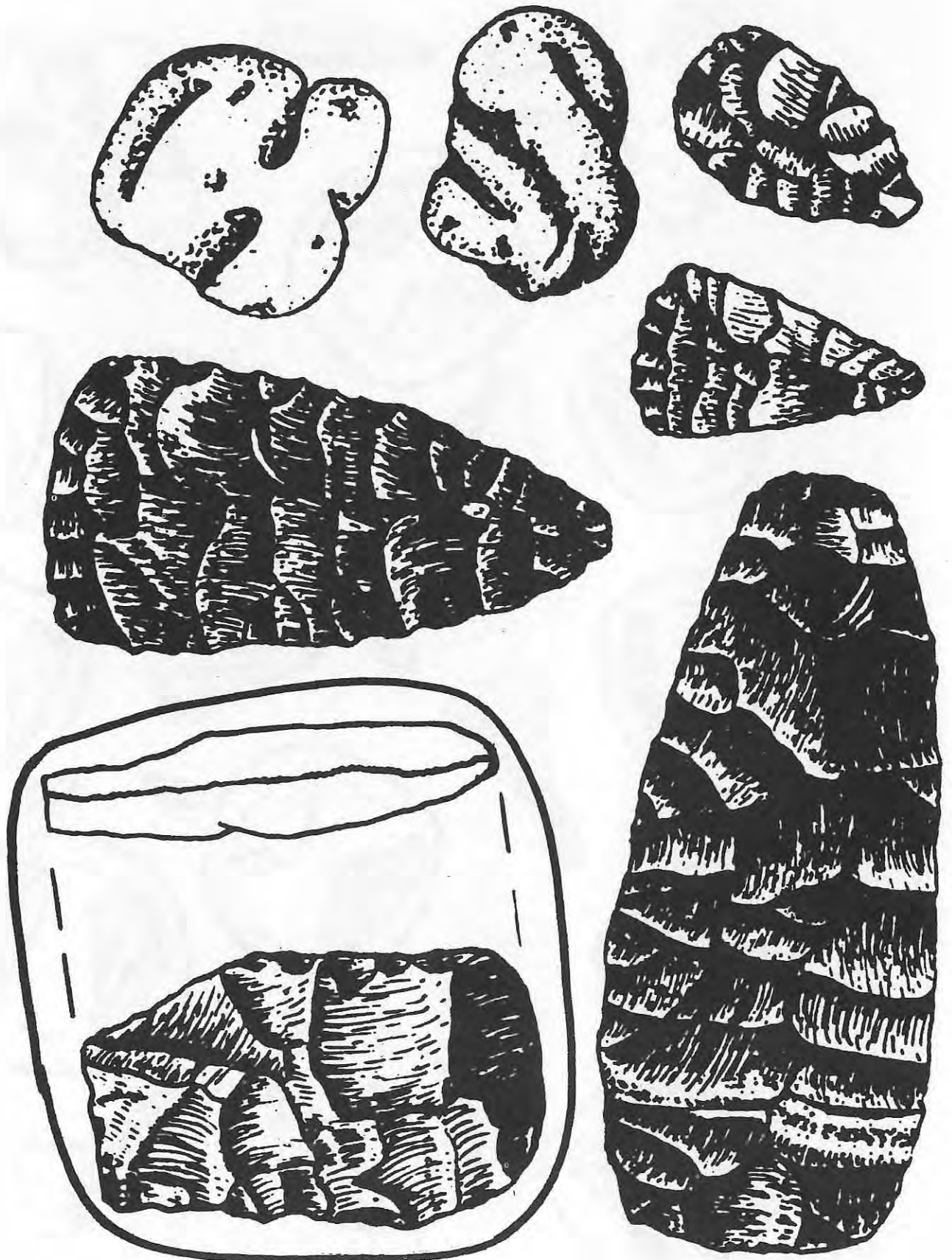



# Artifacts from the Southwest Section

*Photocopy one copy on card stock*

*Clarence H. Webb (1982)*

*courtesy of LSU Dept. of Geography and Anthropology*

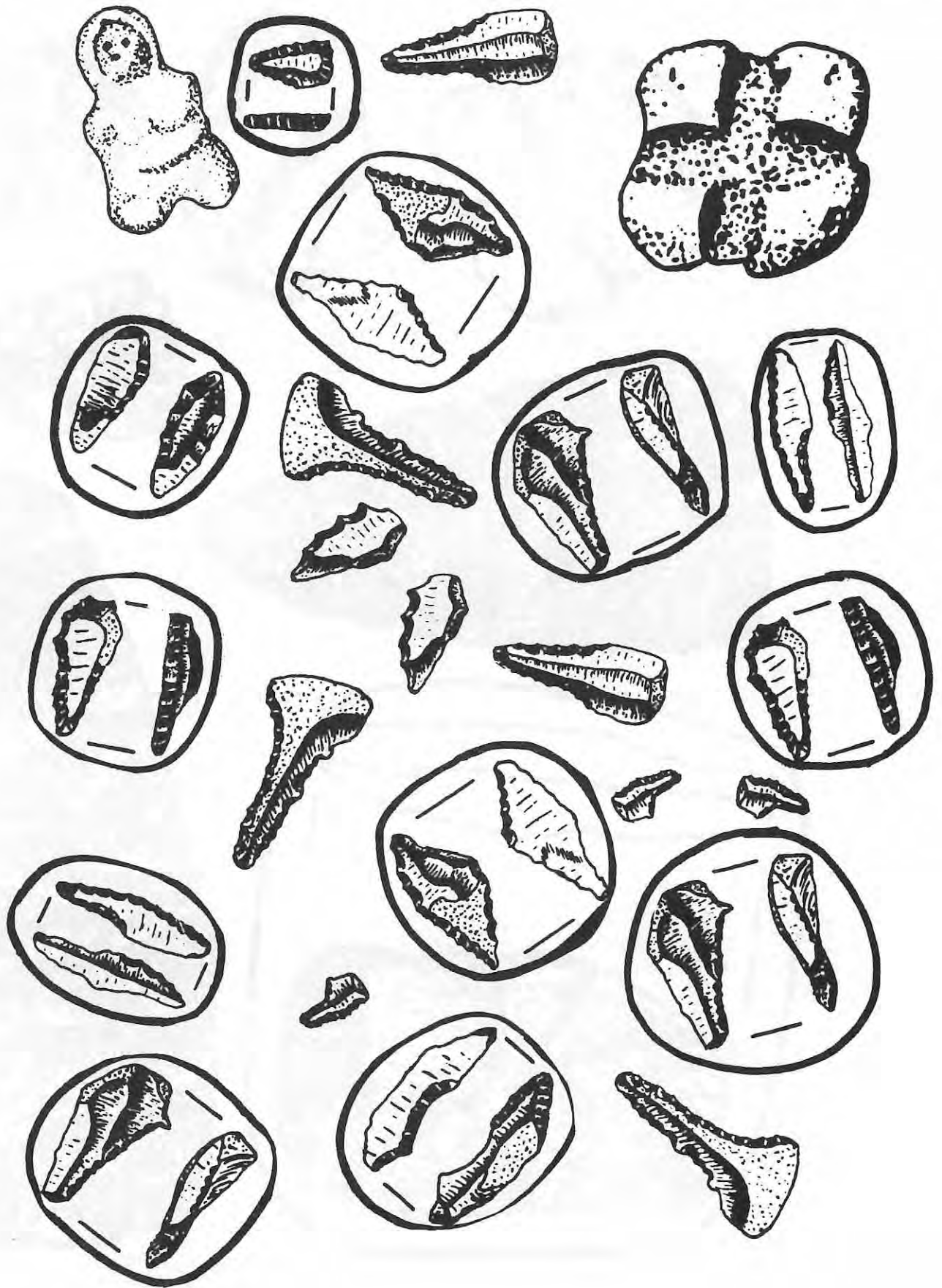

# Artifacts from the Southwest Section

*Photocopy one copy on card stock*

*Clarence H. Webb (1982)*

*courtesy of LSU Dept. of Geography and Anthropology*

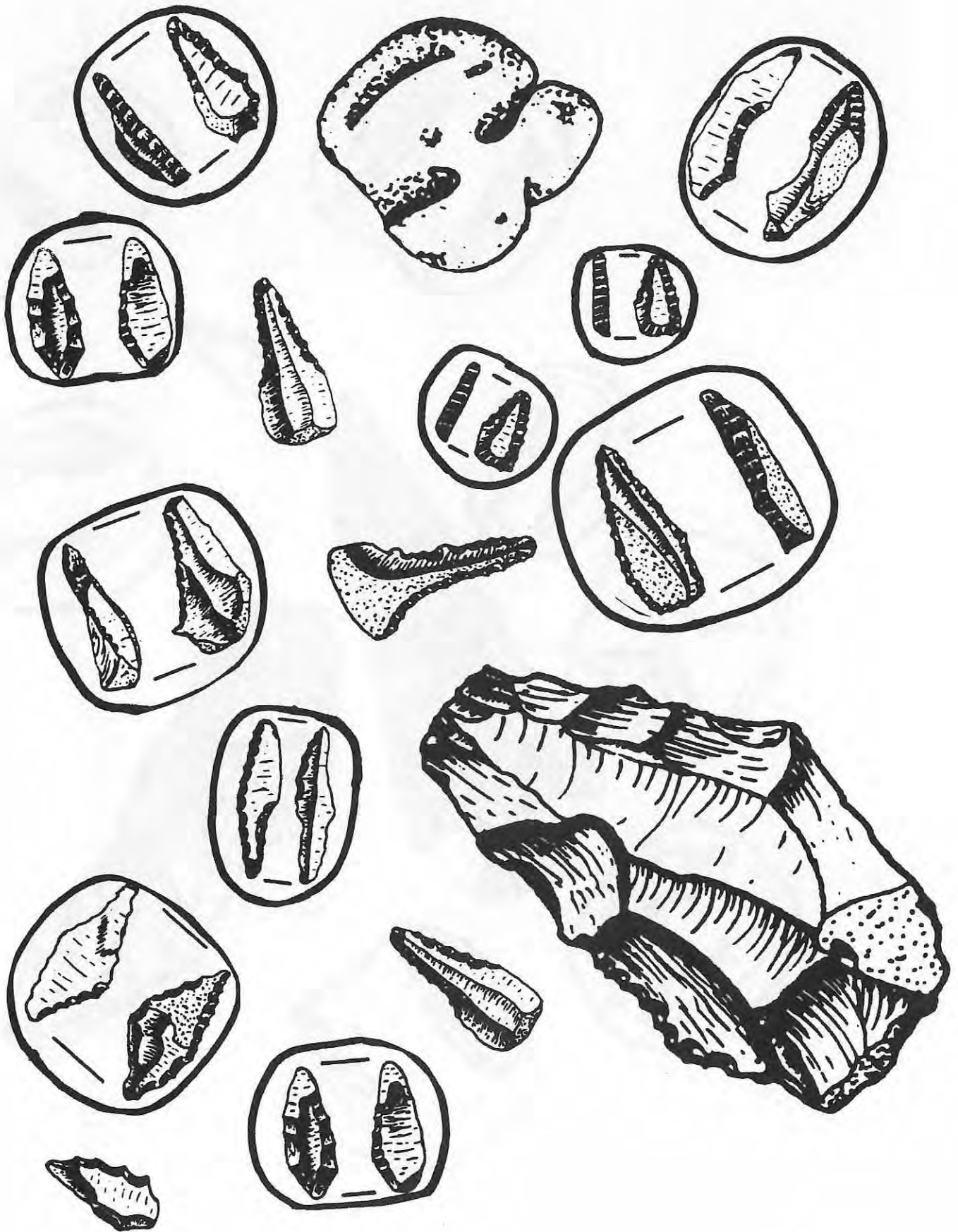



# Artifacts from the Southwest Section

*Photocopy one copy on card stock*

*Clarence H. Webb (1982)*

*courtesy of LSU Dept. of Geography and Anthropology*

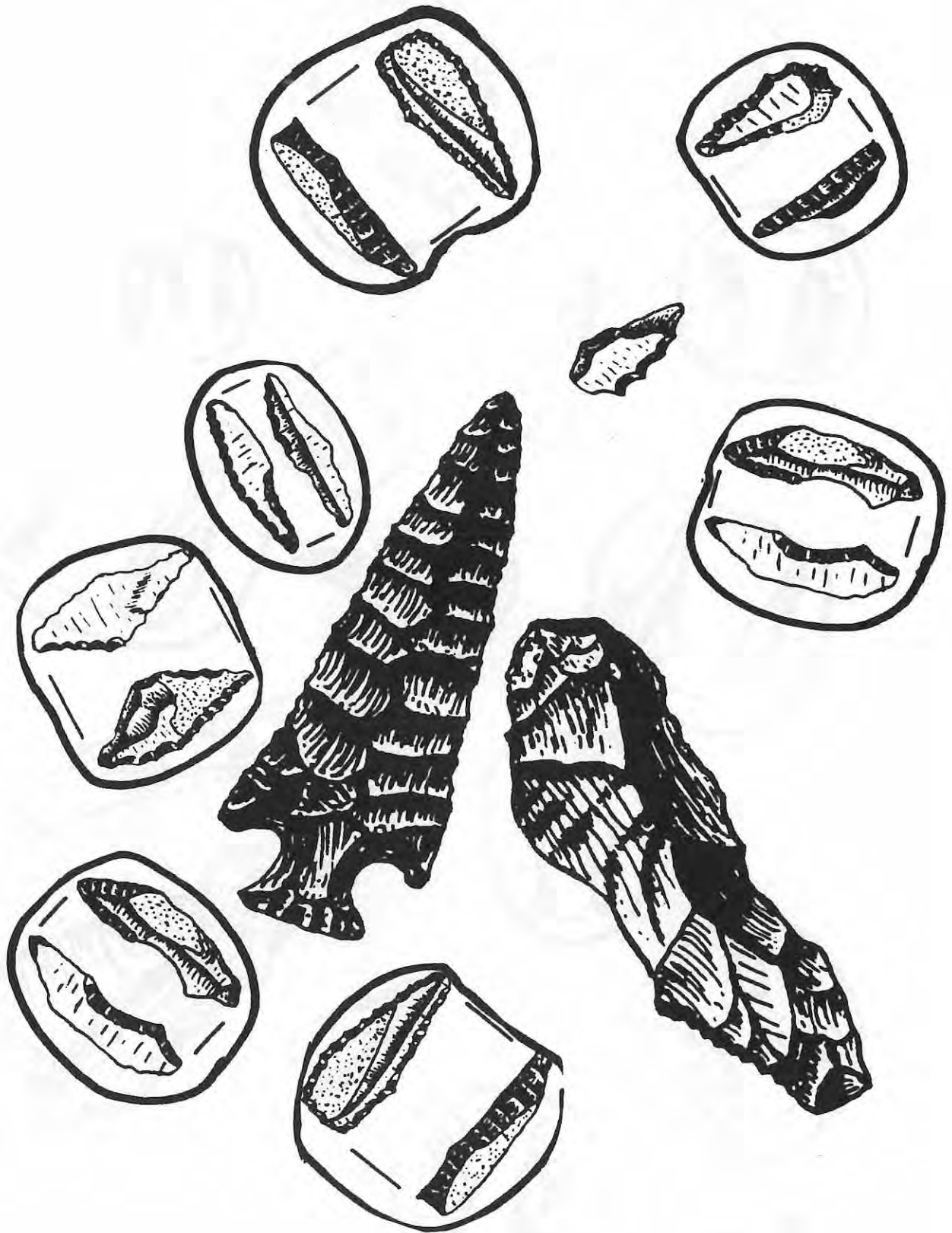

# Artifacts from the West Section

*Photocopy one copy on card stock*

*Clarence H. Webb (1982)*

*courtesy of LSU Dept. of Geography and Anthropology*

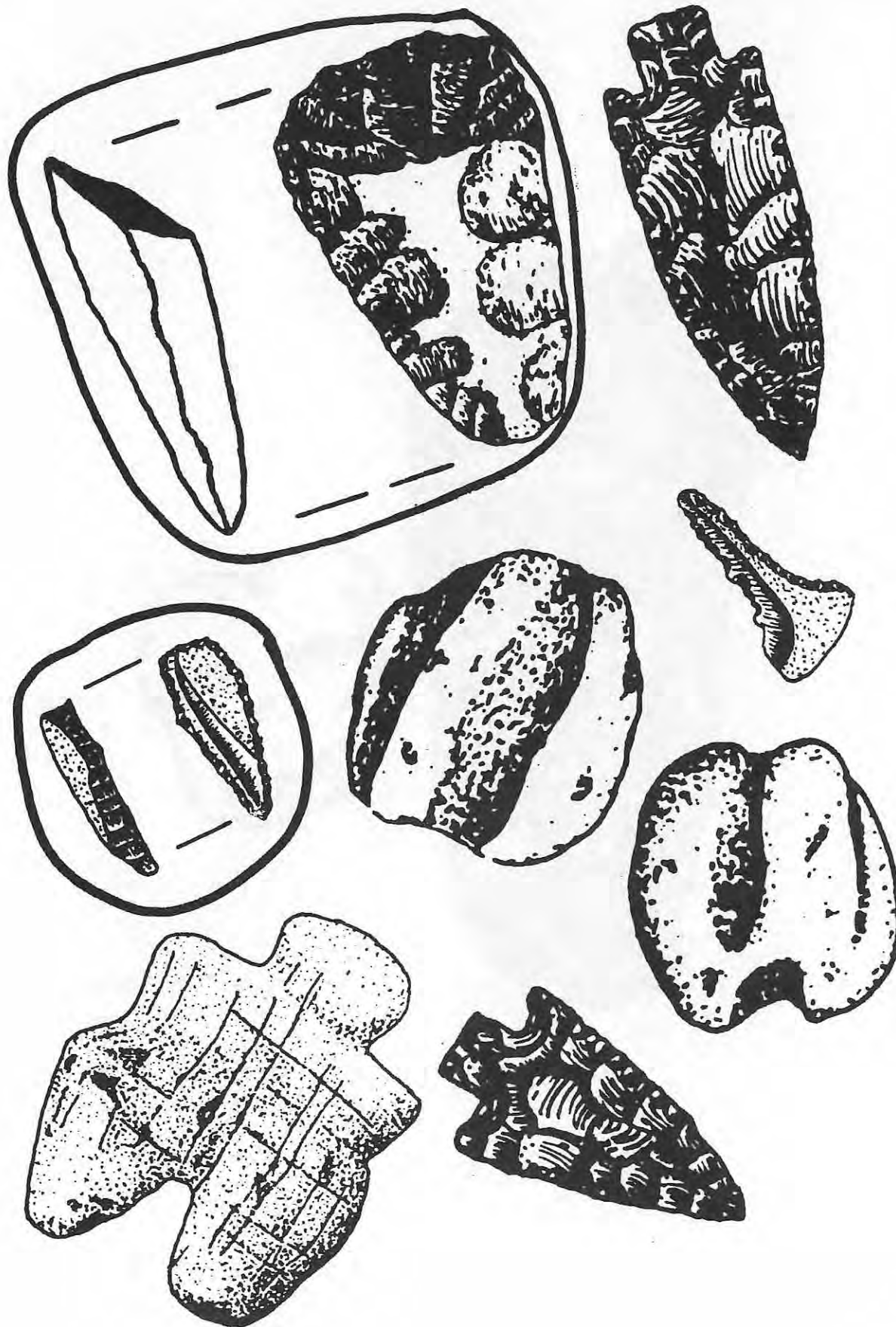

# Artifacts from the West Section

*Photocopy one copy on card stock*

*Clarence H. Webb (1982)*

*courtesy of LSU Dept. of Geography and Anthropology*

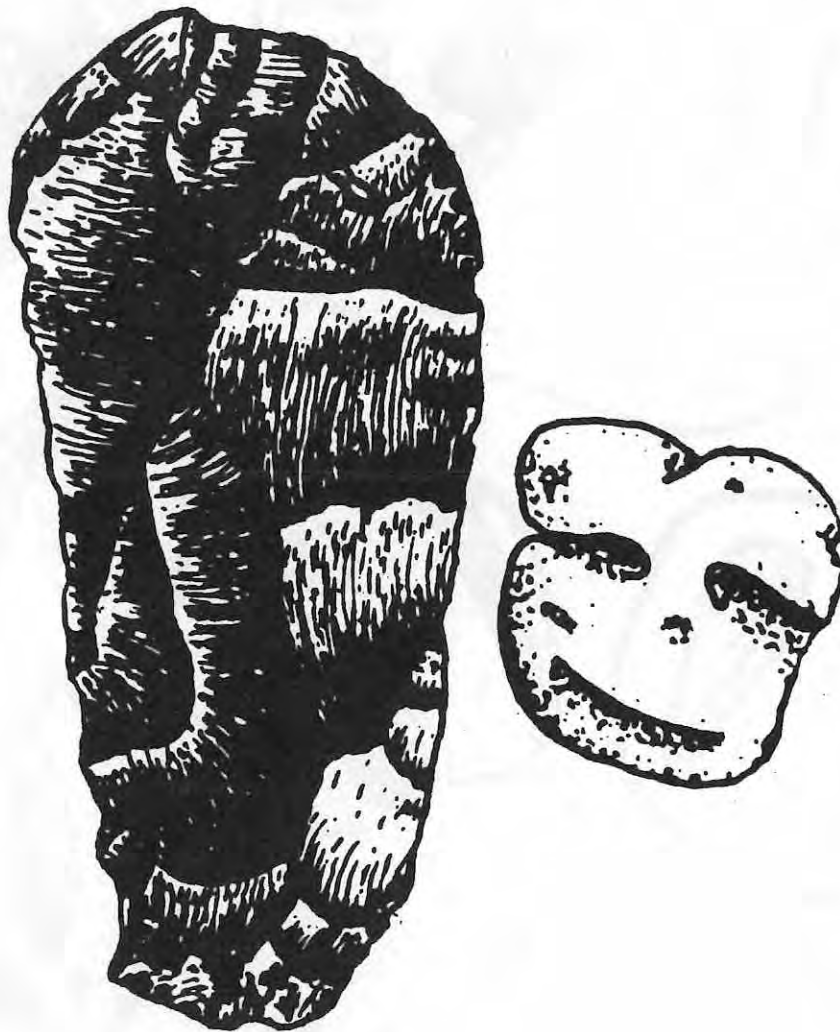

# Artifacts from the Northwest Section

*Photocopy one copy on card stock*

*Clarence H. Webb (1982)*

*courtesy of LSU Dept. of Geography and Anthropology*

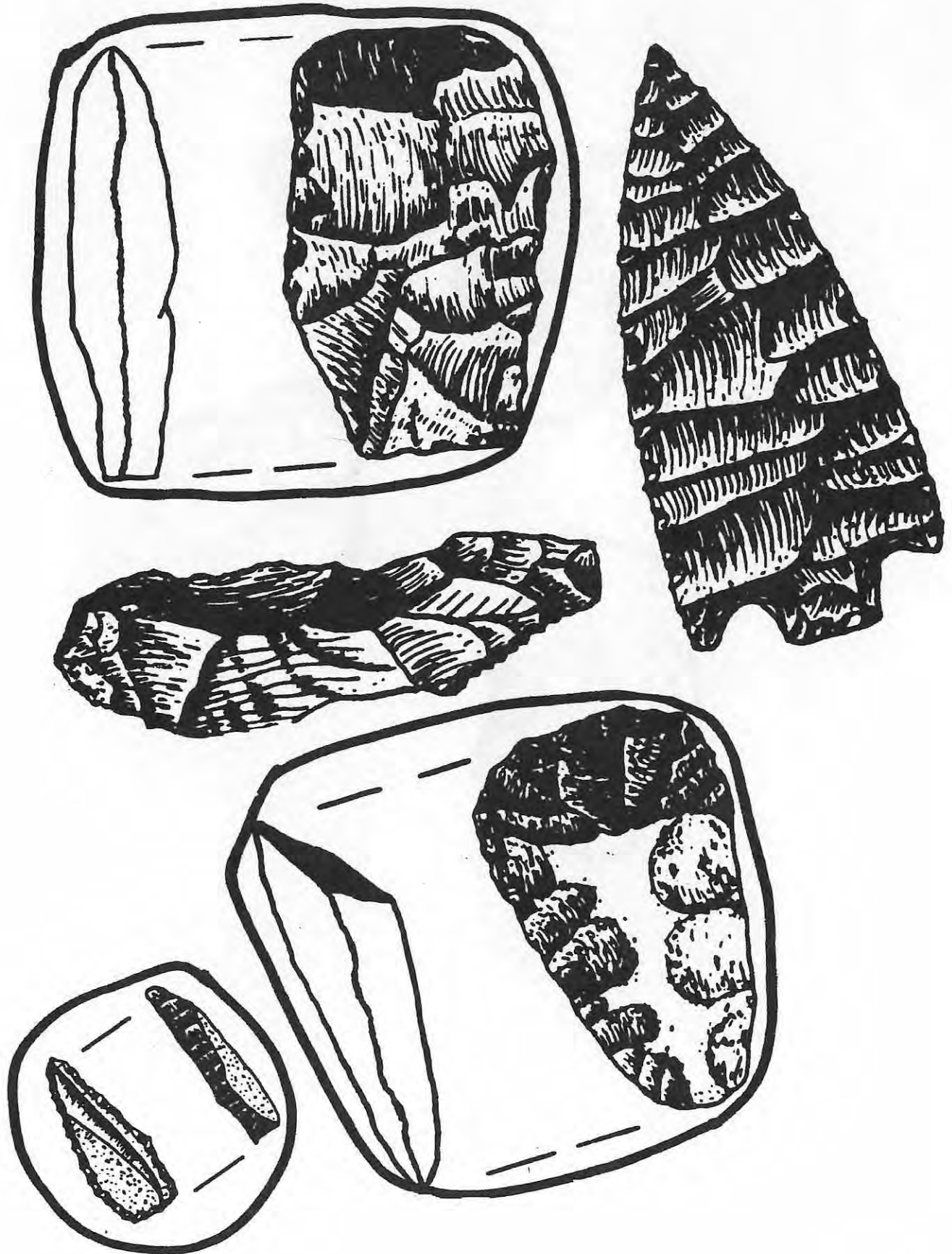

# Artifacts from the Northwest Section

*Photocopy one copy on card stock*

*Clarence H. Webb (1982)*

*courtesy of LSU Dept. of Geography and Anthropology*





# Artifacts from the North Section

Photocopy one copy on card stock

Clarence H. Webb (1982)

courtesy of LSU Dept. of Geography and Anthropology

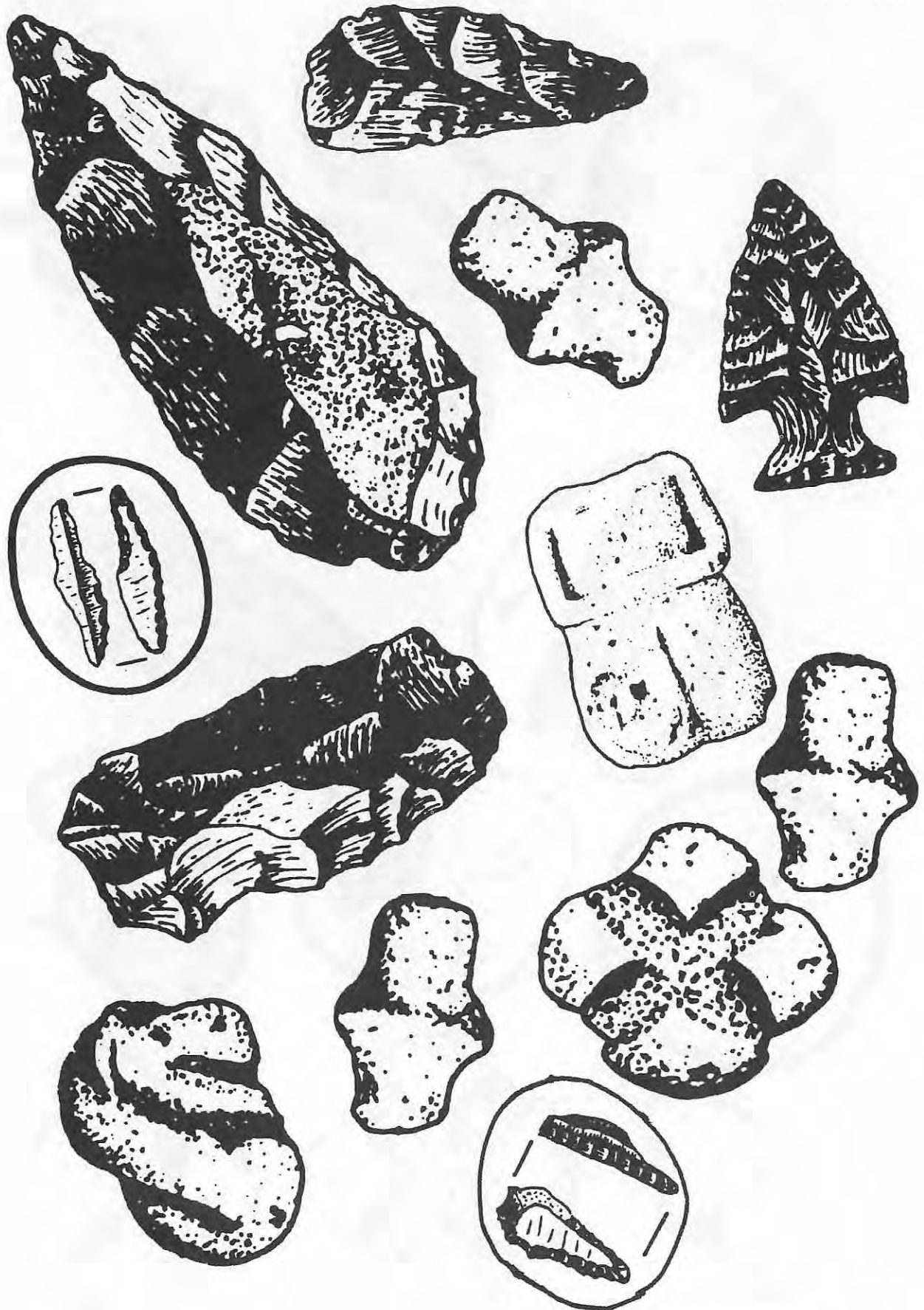

# Artifacts from the North Section

*Photocopy one copy on card stock*

*Clarence H. Webb (1982)*

*courtesy of LSU Dept. of Geography and Anthropology*

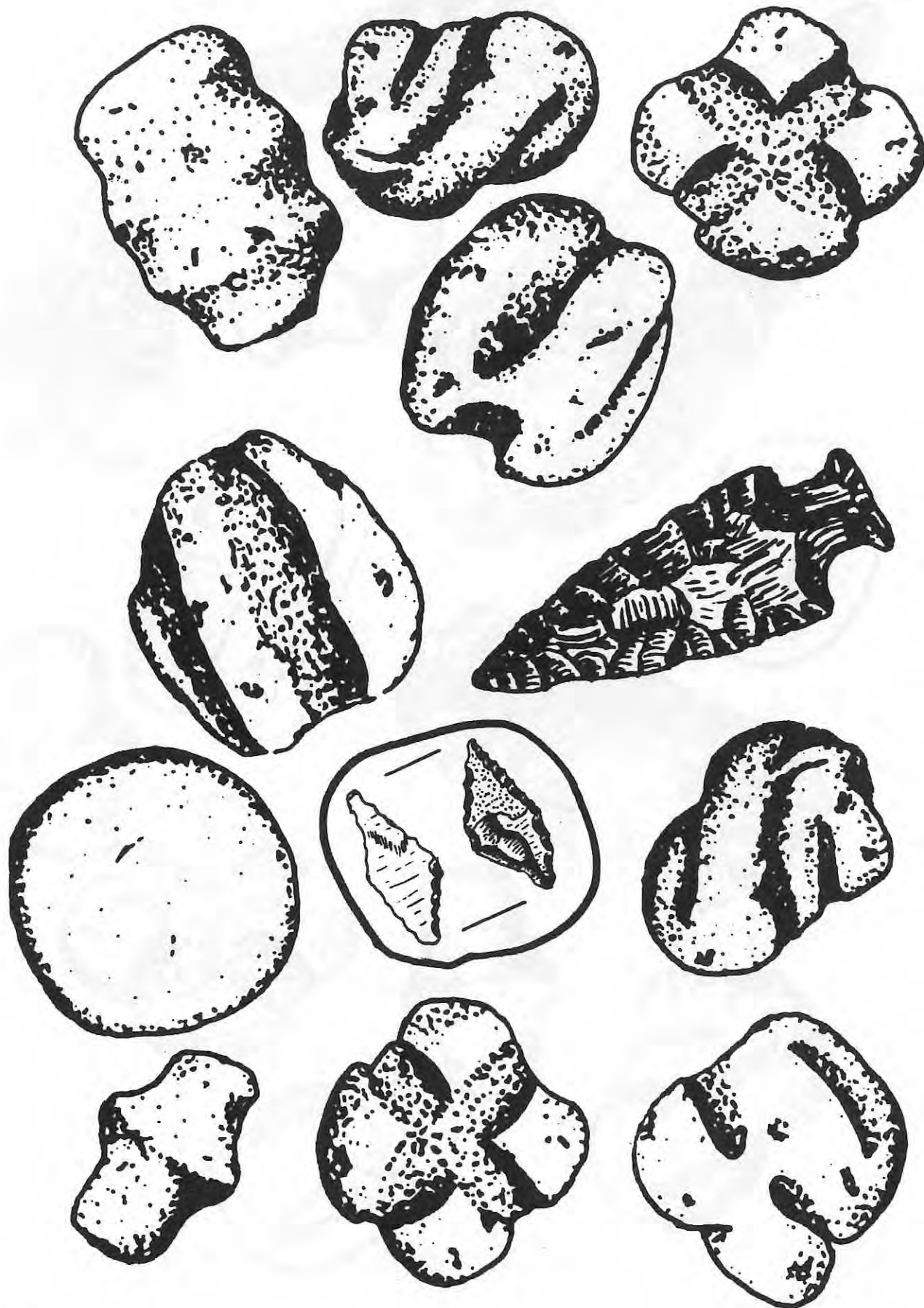

# Artifacts from the North Section

*Photocopy one copy on card stock*

*Clarence H. Webb (1982)*

*courtesy of LSU Dept. of Geography and Anthropology*

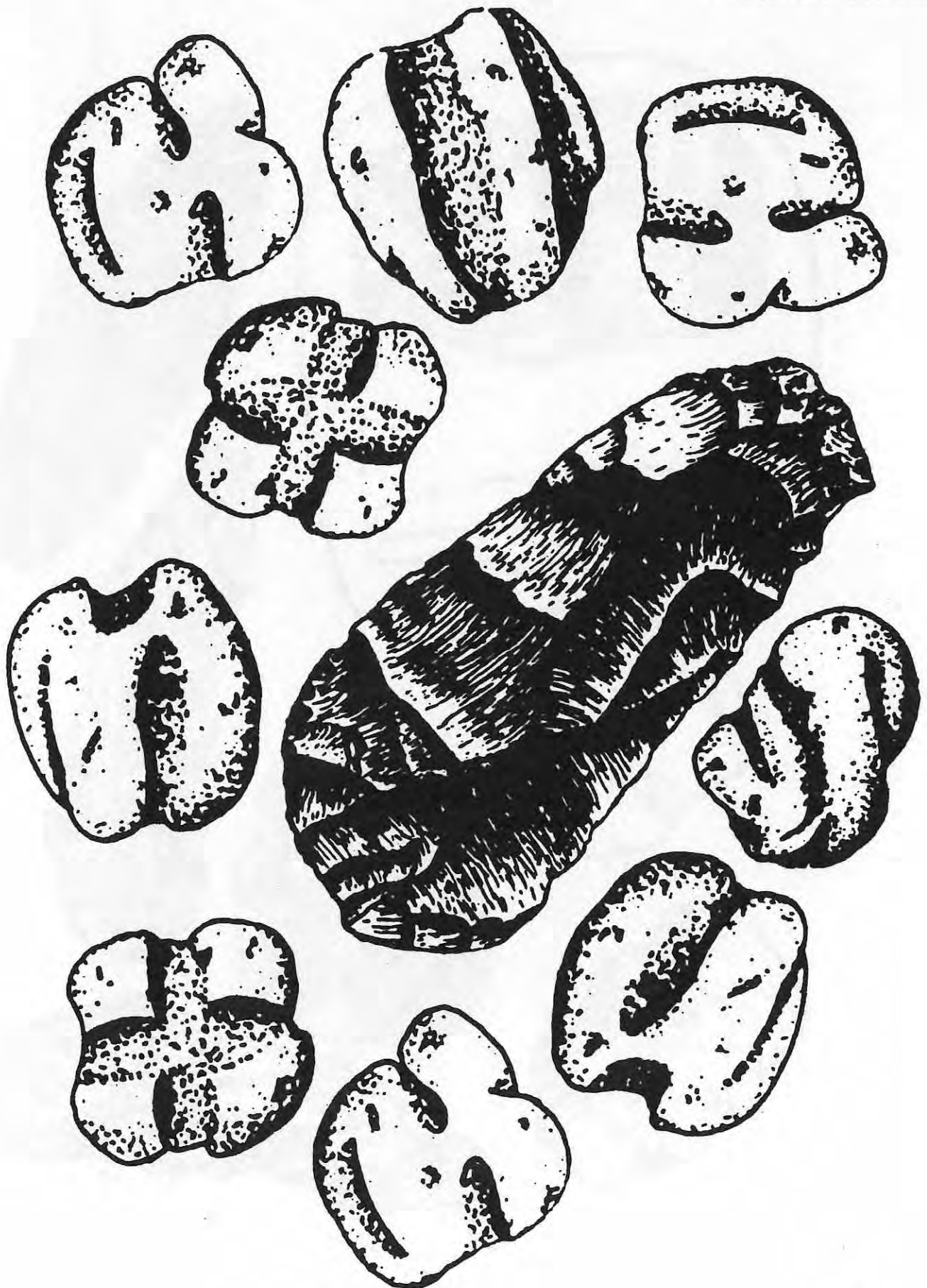

# Artifacts from the North Section

*Photocopy one copy on card stock*

*Clarence H. Webb (1982)*

*courtesy of LSU Dept. of Geography and Anthropology*

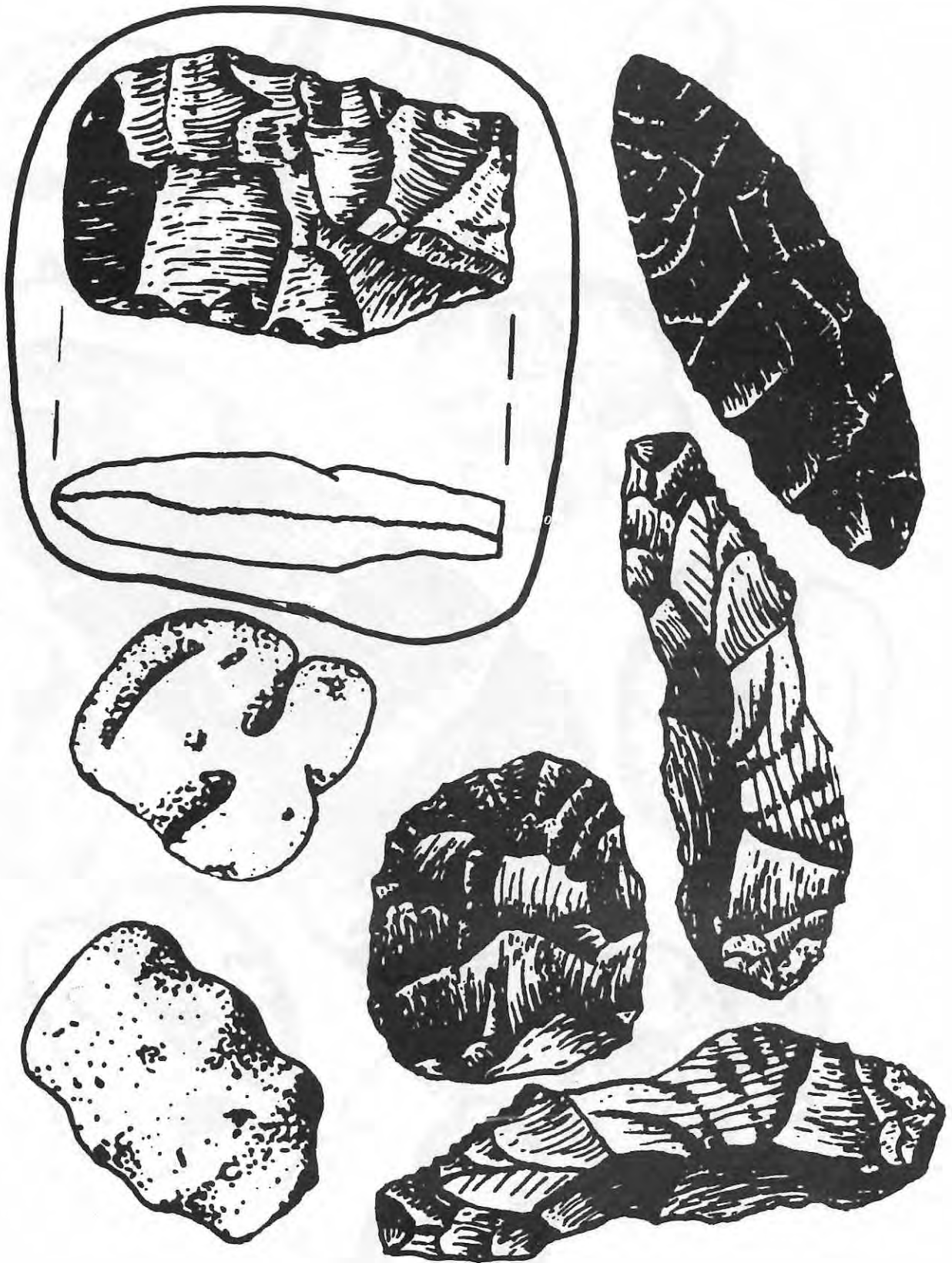



# Artifacts from the North Section

*Photocopy one copy on card stock*

*Clarence H. Webb (1982)*

*courtesy of LSU Dept. of Geography and Anthropology*

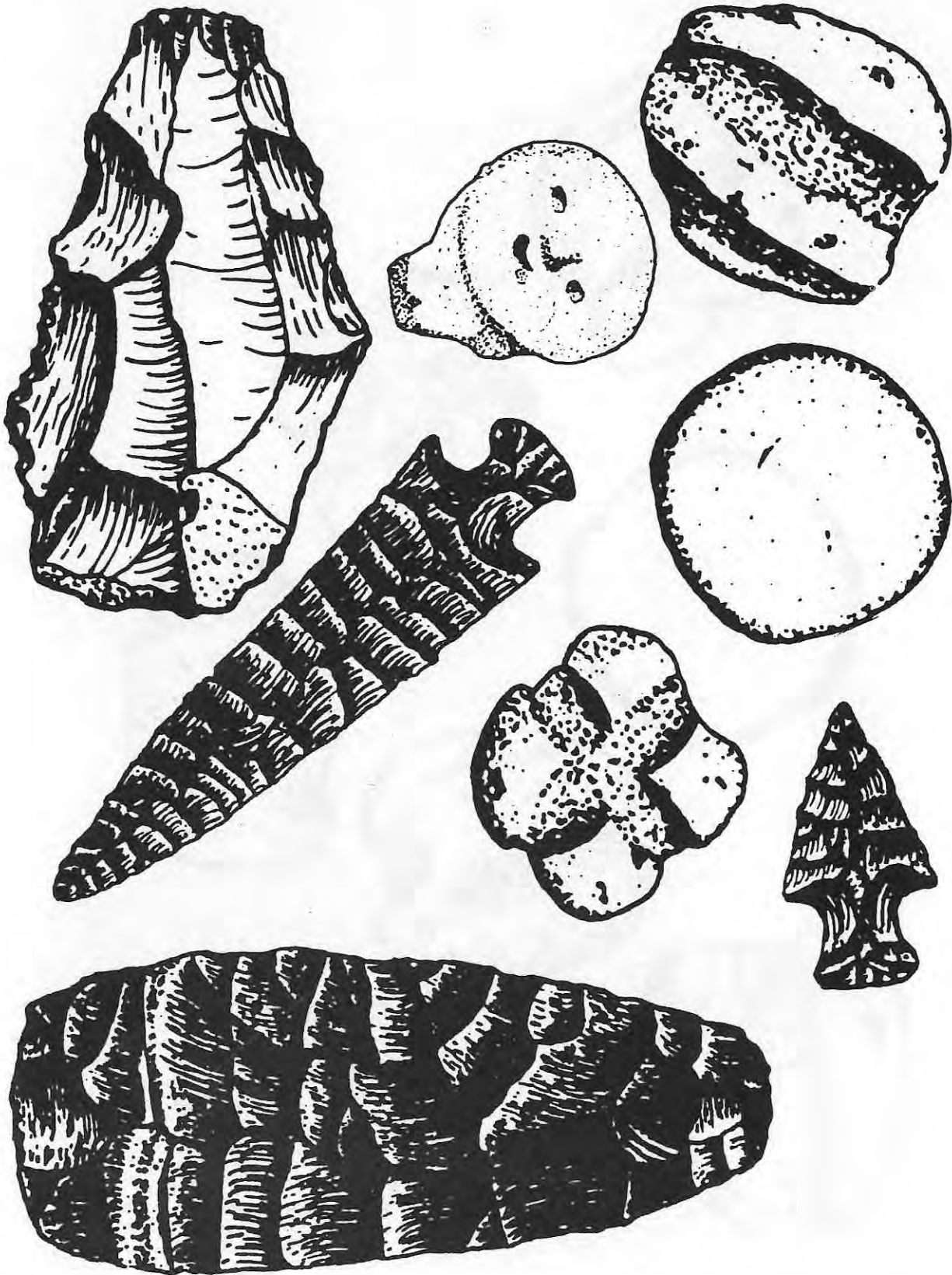



# Artifacts from the North Section

*Photocopy one copy on card stock*

*Clarence H. Webb (1982)*

*courtesy of LSU Dept. of Geography and Anthropology*



# Appendixes



# Appendix A

## Suggestions for Authentic Assessment

Assessment	Description	Activity
Project	Long term assignment	The “Do It Yourself” Atlatl Independent Project for Students  Independent Research Project as an optional extension of student interests
Presentation	Present completed project in oral or activity form	Presentation of cooperative group results for: The Run for the Ridges Atlatl Antics Poverty Point Ovens Artifacts All Over the Place  Dramatic presentation of Mythology play for Bird Gods? Fox Man? Long Tail?  Oral presentation of Perplexing Poverty Point Figurine stories
Cooperative Grouping	Work cooperatively to achieve a common goal	Create a cooperative group check list for group self evaluation following each activity: Building a Mound for the Birds! Wattle You Build Next? Atlatl Antics Poverty Point Ovens Artifacts All Over the Place
Peer Assessment	Collaboration on assignments, explaining concepts to peers, or questioning peers on how to proceed with an assignment	Create a peer evaluation checklist to be used at the end of collaborative activities: Building a Mound for the Birds! Home, Home on the Ridge Wattle You Build Next? Poverty Point Ovens Atlatl Antics Poverty Point Cooking Balls Cooking in an Earth Oven Artifacts All Over the Place
Self Assessment	Student evaluation of processing, action, and progress	Create a self evaluation checklist to be used at the end of activities

Class Work	Review of daily work	Teacher review of student data sheets, summaries, creative writing, and all other written work
Teacher Observation	Observe student performance	Informal observation or logging of student behaviors as needed



# Appendix B

## Correlation to Louisiana State Standards for Curriculum Development Grades K-4

### English/Language Arts Content Standards for K-4

Benchmark #	Description	Activity
ELA-1-E1	gaining meaning from print and building vocabulary using a full range of strategies	All activities
ELA-1-E2	using the conventions of print	All activities
ELA-1-E4	identifying story elements and literary devices within a selection	Bird Gods? Fox Man? Long Tail? Perplexing Poverty Point Figurines
ELA-1-E6	interpreting texts to generate connections to real-life situations	All activities
ELA-2-E1	dictating or writing a composition that clearly states or implies a central idea with supporting details in a logical, sequential order	Perplexing Poverty Point Figurines Bird Gods? Fox Man? Long Tail?
ELA-2-E3	creating written texts using the writing process	Perplexing Poverty Point Figurines Bird Gods? Fox Man? Long Tail?
ELA-3-E1	write legibly	Atlatl Antics Poverty Point Ovens Perplexing Poverty Point Figurines Bird Gods? Fox Man? Long Tail? Artifacts All Over the Place
ELA-3-E2	demonstrating use of punctuation, capitalization, and abbreviations in final drafts of writing assignments	Atlatl Antics Poverty Point Ovens Perplexing Poverty Point Figurines Bird Gods? Fox Man? Long Tail? Artifacts All Over the Place

ELA-3-E3	demonstrating standard English structure and usage	Atlatl Antics Poverty Point Ovens Perplexing Poverty Point Figurines Bird Gods? Fox Man? Long Tail? Artifacts All Over the Place
ELA-3-E4	using knowledge of the parts of speech to make choices for writing	Poverty Point Ovens Perplexing Poverty Point Figurines Bird Gods? Fox Man? Long Tail? Artifacts All Over the Place
ELA-3-E5	spelling accurately using strategies and resources when necessary	Poverty Point Ovens Perplexing Poverty Point Figurines Bird Gods? Fox Man? Long Tail? Artifacts All Over the Place
ELA-4-E1	speaking intelligibly, using standard English pronunciation	Bird Gods? Fox Man? Long Tail? Artifacts All Over the Place
ELA-4-E2	giving and following directions/procedures	All activities
ELA-4-E3	telling or retelling stories in sequence	Bird Gods? Fox Man? Long Tail?
ELA-4-E4	giving rehearsed or unrehearsed presentations	Bird Gods? Fox Man? Long Tail?
ELA-4-E7	participating in a variety of roles in group discussions	Topography Training Building a Mound for the Birds! The Run for the Ridges Home, Home on the Ridge Wattle You Build Next? Atlatl Antics Cooking in an Earth Oven Poverty Point Ovens Artifacts All Over the Place
ELA-6-E2	recognizing and responding to a variety of classic and contemporary literature from many genres (myths, folk tales, etc.)	Bird Gods? Fox Man? Long Tail?
ELA-7-E2	problem solving by using reasoning skills, life experiences, and available information	The Run for the Ridges Atlatl Antics Poverty Point Ovens Artifacts All Over the Place
ELA-7-E4	distinguishing fact from opinion, skimming, and scanning for facts, determining cause and effect, generating inquiry, and making connections with real-life situations	All activities

## Louisiana Science Framework for K-4

Benchmark #	Description	Activity
S1-E-A2	planning and/or designing and conducting a scientific investigation.	Atlatl Antics Poverty Point Ovens Artifacts All Over the Place
S1-E-A3	communicating that observations are made with one's senses	Atlatl Antics Poverty Point Ovens Artifacts All Over the Place
S1-E-A4	employing equipment and tools to gather data and extend the sensory observations	Atlatl Antics Poverty Point Ovens Artifacts All Over the Place
S1-E-A5	using data, including numbers and graphs, to explain observations and experiments	Atlatl Antics Poverty Point Ovens Artifacts All Over the Place
S1-E-A6	communicating observations and experiments in oral and written formats	Topography Training Atlatl Antics Poverty Point Ovens Artifacts All Over the Place
S1-E-A7	utilizing safety procedures during experiments	Atlatl Antics The "Do It Yourself" Atlatl Cooking in an Earth Oven Poverty Point Ovens Prehistoric Pump Drills
S1-E-B4	developing explanations by using observations and experiments	Atlatl Antics The "Do It Yourself" Atlatl Poverty Point Ovens Prehistoric Pump Drills Artifacts All Over the Place
S1-E-B5	presenting the results of experiments	Atlatl Antics Poverty Point Ovens Prehistoric Pump Drills
S1-E-B6	reviewing and asking questions about the results of investigations	Atlatl Antics Poverty Point Ovens Artifacts All Over the Place
PS-E-A1	observing, describing, and classifying objects by properties	Poverty Point Cooking Balls Artifacts All Over the Place
PS-E-B1	observing and describing the position of an object relative to another object or the background	Atlatl Antics

PS-E-B3	describing an object's motion by tracing and measuring its position over time	Atlatl Antics
PS-E-C3	investigating and describing different ways heat can be produced and moved from one object to another by conduction	Poverty Point Cooking Balls Cooking in an Earth Oven Poverty Point Ovens
ESS-E-A6	observing and describing variations in soil	Poverty Point Cooking Balls

# Louisiana Social Studies Content Standards for K-4

Benchmark #	Description	Activity
G-1A-E1	identifying and describing the characteristics and uses of geographic representations, such as various types of maps, globes, graphs, diagrams, photographs, and satellite-produced images	Our Poverty Point Addresses Topography Training Building a Mound for the Birds! Poverty Point Cooking Balls Artifacts All Over the Place
G-1A-E2	locating and interpreting geographic features and places on maps and globes	Our Poverty Point Addresses Topography Training Building a Mound for the Birds! Poverty Point Cooking Balls Artifacts All Over the Place
G-1A-E3	constructing maps, graphs, charts, and diagrams to describe geographical information and to solve problems	Our Poverty Point Addresses Topography Training Building a Mound for the Birds! Artifacts All Over the Place
G-1B-E1	describing and comparing the physical characteristics of places, including land forms, bodies of water, soil, vegetation, and climate	Our Poverty Point Addresses Poverty Point Cooking Balls
G-1C-E5	locating and explaining the spatial distribution of economic activities	Artifacts All Over the Place
G-1D-E1	identifying and explaining ways in which people depend upon and modify the physical environment	Home, Home on the Ridge Wattle You Build Next? Poverty Point Cooking Balls
G-1D-E2	describing how humans adapt to variations in the physical environment	Poverty Point Cooking Balls Cooking in an Earth Oven
G-1D-E4	describing use, distribution, and importance of natural resources	Home, Home on the Ridge Wattle You Build Next? Poverty Point Cooking Balls
E-1A-E7	describing how specialization affects productivity and contributes to the need for interdependence among producers and consumers	Poverty Point Cooking Balls Artifacts All Over the Place
H-1A-E1	demonstrating an understanding of the concepts of time and chronology	Time Line of History
H-1A-E3	identifying and using primary and secondary historical sources to learn about the past	All activities



H-1C-E4	recognizing how folklore and other cultural elements have contributed to our local, state, and national heritage	Perplexing Poverty Point Figurines Bird Gods? Fox Man? Long Tail?
H-1D-E1	identifying the characteristics and historical development of selected societies throughout the world	Time Line of History Building a Mound for the Birds! The "Do It Yourself" Atlatl Poverty Point Cooking Balls Prehistoric Pump Drills Artifacts All Over the Place
H-1D-E2	describing the social and economic impact of major scientific and technological advancements	Atlatl Antics Prehistoric Pump Drills

## Louisiana Mathematics Framework for K-4

Benchmark #	Description	Activity
N-4-E	demonstrating a conceptual understanding of the meaning of the basic arithmetic operations and their relationships to each other	Time Line of History The Run for the Ridges Home, Home on the Ridge Atlatl Antics Poverty Point Ovens Artifacts All Over the Place
N-5-E	selecting appropriate operation(s) for a given situation	The Run for the Ridges
N-6-E	applying a knowledge of basic math facts and arithmetic operations to real-life situations	Time Line of History The Run for the Ridges Home, Home on the Ridge Atlatl Antics Poverty Point Ovens Artifacts All Over the Place
N-7-E	constructing, using, and explaining procedures to compute and estimate with whole numbers	Time Line of History The Run for the Ridges Home, Home on the Ridge
M-1-E	applying the concepts of length, area, surface area, volume, capacity, weight, mass, money, time, temperature, and rate to real world experiences	Time Line of History The Run for the Ridges Our Poverty Point Addresses Cooking in an Earth Oven Poverty Point Ovens
M-4-E	converting from one unit of measurement to another within the same system	Time Line of History The Run for the Ridges
M-5-E	demonstrating the connection of measurement to the other strands and to real-life situations	Time Line of History Our Poverty Point Addresses Topography Training Building a Mound for the Birds! The Run for the Ridges Home, Home on the Ridge Atlatl Antics The “Do It Yourself” Atlatl Poverty Point Ovens Prehistoric Pump Drills
G-2-E	identifying, describing, comparing, constructing, and classifying geometric figures and concepts	Home, Home on the Ridge

G-4-E	drawing, constructing models, and comparing geometric shapes, with special attention to developing spatial sense	Our Poverty Point Addresses Topography Training Building a Mound for the Birds! Home, Home on the Ridge Wattle You Build Next?
G-6-E	demonstrating the connection of geometry to the other strands and to real-life situations	Home, Home on the Ridge
D-1-E	collecting, organizing, and describing data based on real-life situations	The Run for the Ridges Atlatl Antics Poverty Point Ovens Artifacts All Over the Place
D-2-E	constructing, reading, and interpreting data in charts, graphs, tables, etc.	Atlatl Antics Poverty Point Ovens Artifacts All Over the Place
D-3-E	formulating and solving problems that involve the use of data	The Run for the Ridges Atlatl Antics Poverty Point Ovens Artifacts All Over the Place
D-6-E	demonstrating the connection of data analysis, probability, and discrete math to other strands and to real-life situations	Atlatl Antics Poverty Point Ovens Artifacts All Over the Place

# Appendix C

## Correlation to Louisiana State Standards for Curriculum Development Grades 5-8

### English/Language Arts Content Standards for 5-8

Benchmark #	Description	Activity
ELA-1-M1	using knowledge of word meaning and developing basic and technical vocabulary using various strategies	All activities
ELA-1-M2	analyzing literary devices and story elements	Perplexing Poverty Point Figurines Bird Gods? Fox Man? Long Tail?
ELA-2-M1	writing a composition that clearly implies a central idea with supporting details in a logical, sequential order	Perplexing Poverty Point Figurines Bird Gods? Fox Man? Long Tail?
ELA-2-M3	applying the steps of the writing process	Perplexing Poverty Point Figurines Bird Gods? Fox Man? Long Tail?
ELA-3-M1	write legibly	Poverty Point Ovens Perplexing Poverty Point Figurines Bird Gods? Fox Man? Long Tail? Artifacts All Over the Place
ELA-3-M2	demonstrating use of punctuation, capitalization, and abbreviations	Poverty Point Ovens Perplexing Poverty Point Figurines Bird Gods? Fox Man? Long Tail? Artifacts All Over the Place
ELA-3-M3	demonstrating standard English structure and usage	Poverty Point Ovens Perplexing Poverty Point Figurines Bird Gods? Fox Man? Long Tail? Artifacts All Over the Place
ELA-3-M4	demonstrating understanding of the parts of speech to make choices for writing	Poverty Point Ovens Perplexing Poverty Point Figurines Bird Gods? Fox Man? Long Tail? Artifacts All Over the Place

ELA-3-M5	spelling accurately using strategies and resources when necessary	Poverty Point Ovens Perplexing Poverty Point Figurines Bird Gods? Fox Man? Long Tail? Artifacts All Over the Place
ELA-4-M1	speaking intelligibly, using standard English pronunciation and diction	Bird Gods? Fox Man? Long Tail? Artifacts All Over the Place
ELA-4-M2	giving and following directions/procedures	All activities
ELA-4-M4	speaking and listening for a variety of audiences and purposes	Bird Gods? Fox Man? Long Tail? and all small group work
ELA-4-M6	participating in a variety of roles in group discussions	Topography Training Building a Mound for the Birds! The Run for the Ridges Home, Home on the Ridge Wattle You Build Next? Atlatl Antics Cooking in an Earth Oven Poverty Point Ovens Artifacts All Over the Place
ELA-6-M2	identifying, comparing, and responding to a variety of classic and contemporary literature from many genres (myths, folk tales, etc.)	Bird Gods? Fox Man? Long Tail?
ELA-7-M2	problem solving by using reasoning skills, life experiences, accumulated knowledge, and relevant information	Atlatl Antics Poverty Point Ovens Artifacts All Over the Place
ELA-7-M4	distinguishing fact from opinion and probability, skimming and scanning for facts, determining cause and effect, inductive and deductive reasoning, generating inquiry, and making connections with real-life situations across texts.	All activities



## Louisiana Science Framework for 5-8

Benchmark #	Description	Activity
S1-M-A2	designing and conducting a scientific investigation.	Atlatl Antics Poverty Point Ovens Artifacts All Over the Place
S1-M-A3	using mathematics and appropriate tools and techniques to gather, analyze, and interpret data.	Atlatl Antics Poverty Point Ovens Artifacts All Over the Place
S1-M-A4	developing descriptions, explanations, predictions, and graphs using data.	Atlatl Antics Poverty Point Ovens Artifacts All Over the Place
S1-M-A5	developing models and predictions using the relationships between data and explanations	Atlatl Antics Poverty Point Ovens Artifacts All Over the Place
S1-M-A6	comparing alternative explanations and predictions	Poverty Point Ovens
S1-M-A7	communicating scientific procedures, information, and explanations	Atlatl Antics Poverty Point Ovens Artifacts All Over the Place
S1-M-A8	utilizing safety procedures during scientific investigations.	Atlatl Antics The “Do It Yourself” Atlatl Cooking in an Earth Oven Poverty Point Ovens Prehistoric Pump Drills
S1-M-B1	understanding that different kinds of questions guide different kinds of scientific investigations	Poverty Point Ovens
S1-M-B5	understanding that scientific knowledge is enhanced through peer review, alternative explanations, and constructive criticism	Artifacts All Over the Place
PS-M-B1	describing and graphing the motions of objects	Atlatl Antics
PS-M-C5	investigating and describing the movement of heat	Cooking in an Earth Oven Poverty Point Ovens
SE-M-A6	distinguishing between renewable and nonrenewable resources and understanding that nonrenewable resources are not replenished through the natural cycles and thus are strictly limited in quantity	Topography Training

## Louisiana Social Studies Content Standards for 5-8

Benchmark #	Description	Activity
G-1A-M1	identifying and describing the characteristics, functions, and applications of various types of maps and other geographic tools, and technologies.	Our Poverty Point Addresses Topography Training Building a Mound for the Birds! Poverty Point Cooking Balls
G-1A-M2	interpreting and developing maps, globes, graphs, charts, models, and databases to analyze spatial distributions and patterns.	Our Poverty Point Addresses Artifacts All Over the Place
G-1A-M3	organizing and displaying information about the location of geographic features and places by using mental mapping skills.	Our Poverty Point Addresses
G-1D-M2	explaining and giving examples of how characteristics of different physical environments affect human activities	Poverty Point Cooking Balls Artifacts All Over the Place
E-1A-M1	describing how the scarcity of resources necessitates decision making at both personal and societal levels.	Poverty Point Cooking Balls
E-1A-M4	analyzing the role of specialization in the economic process.	Poverty Point Cooking Balls
H-1A-M4	analyzing historical data using primary and secondary sources	Poverty Point Cooking Balls The “Do It Yourself” Atlatl Prehistoric Pump Drills Artifacts All Over the Place
H-1A-M6	conducting research in efforts to answer historical questions.	Time Line of History Atlatl Antics The “Do It Yourself” Atlatl Poverty Point Ovens Prehistoric Pump Drills
H-1C-M1	describing the earliest human communities	All activities
H-1D-M1	describing the contributions of people, events, movements, and ideas that have been significant in the history of Louisiana	All activities

# Louisiana Mathematics Framework for 5-8

Benchmark #	Description	Activity
N-2-M	demonstrating number sense and estimation skills to describe, order, and compare rational numbers	Time Line of History The Run for the Ridges Atlatl Antics Poverty Point Ovens
N-4-M	demonstrating a conceptual understanding of the meaning of the basic arithmetic operations and their relationships to each other	Time Line of History The Run for the Ridges Home, Home on the Ridge Atlatl Antics Poverty Point Ovens Artifacts All Over the Place
N-5-M	applying an understanding of rational numbers and arithmetic operations to real-life situations	Time Line of History The Run for the Ridges Home, Home on the Ridge Atlatl Antics Poverty Point Ovens Artifacts All Over the Place
N-7-M	selecting and using appropriate computational methods and tools for given situations . . .	Time Line of History The Run for the Ridges
M-1-M	applying the concepts of length, area, surface area, volume, capacity, weight, mass, money, time, temperature, and rate to real world experiences	Time Line of History The Run for the Ridges Our Poverty Point Addresses Cooking in an Earth Oven Poverty Point Ovens
M-3-M	selecting appropriate units and tools for tasks by considering the purpose for the measurement and the precision required for the task	The Run for the Ridges Atlatl Antics
M-5-M	converting from one unit of measurement to another within the same system	Time Line of History The Run for the Ridges
M-6-M	demonstrating the connection of measurement to the other strands and to real-life situations	Time Line of History Our Poverty Point Addresses Topography Training Building a Mound for the Birds! The Run for the Ridges Home, Home on the Ridge Atlatl Antics The “Do It Yourself” Atlatl Poverty Point Ovens Prehistoric Pump Drills

G-2-M	identifying, describing, comparing, constructing, and classifying geometric figures and concepts	Home, Home on the Ridge
G-4-M	constructing two- and three- dimensional models	Our Poverty Point Addresses Topography Training Building a Mound for the Birds! Home, Home on the Ridge Wattle You Build Next? The “Do It Yourself” Atlatl Prehistoric Pump Drills
G-7-M	demonstrating the connection of geometry to the other strands and to real-life situations	Home, Home on the Ridge
D-1-M	systematically collecting, organizing, describing, and displaying data in charts, tables, plots, graphs, and/or spread sheets	Time Line of History Atlatl Antics Poverty Point Ovens Artifacts All Over the Place
D-2-M	analyzing, interpreting, evaluating, drawing inferences, and making estimations, predictions, decisions, and convincing arguments based on organized data	The Run for the Ridges Atlatl Antics Poverty Point Ovens Artifacts All Over the Place
D-3-M	describing informal thinking procedures (e.g. solving elementary logic problems, using Venn diagrams. . .)	Cooking in an Earth Oven Prehistoric Pump Drills
D-6-M	demonstrating the connection of data analysis, probability, and discrete math to other strands and to real-life situations	Atlatl Antics Poverty Point Ovens Artifacts All Over the Place

# Appendix D

## Resources

### Books

- Brown, Dale M., ed. **Mound Builders and Cliff Dwellers (Lost Civilizations)**. New York: Time Life, 1992.
- Byrd, Kathleen M., ed. **The Poverty Point Culture: Local Manifestations, Subsistence Practices, and Trade Networks**. Geoscience and Man, vol. 29. Baton Rouge: Louisiana State University School of Geoscience, 1991.
- Duke, Kate **Archaeologists Dig for Clues**. New York: Harper Collins, 1997.
- Ford, James A. and Clarence H. Webb **Poverty Point, a Late Archaic Site in Louisiana**. Anthropological Papers, vol. 46, part 1. New York: American Museum of Natural History, 1956.
- Gibson, Jon L. **Poverty Point: A Terminal Archaic Culture of the Lower Mississippi Valley**. 2d ed. Anthropological Study Series #7. Baton Rouge: Department of Culture, Recreation, and Tourism, Louisiana Archaeological Survey and Antiquities Commission, 1996.
- Hawkins, Nancy W. **Classroom Archaeology: An Archaeology Activity Guide for Teachers**. 3d ed. Baton Rouge: Division of Archaeology, Office of Cultural Development, Department of Culture, Recreation, and Tourism, 1991.
- Kennedy, Roger G. **Hidden Cities: The Discovery and Loss of Ancient North American Civilization**. New York: Free Press, 1994.
- Kniffen, Fred B. **The Indians of Louisiana**. 2d ed. 1965. Reprint. Gretna: Pelican, 1985.
- Kniffen, Fred B., H. Gregory, and G. Stokes. **The Historic Indian Tribes of Louisiana: From 1542 to the Present**. Baton Rouge: Louisiana State University Press, 1987.
- Mainfort, Jr., Robert C. and Lynne P. Sullivan, eds. **Ancient Earthen Enclosures of the Eastern Woodlands**. Gainesville: University Press of Florida, 1998.
- Moore, Elizabeth and Alice Couvillon. **Louisiana Indian Tales**. Gretna: Pelican, 1990.



- Neuman, Robert W. **An Introduction to Louisiana Archaeology**. Baton Rouge: Louisiana State University Press, 1984.
- Neuman, Robert W. and Nancy W. Hawkins. **Louisiana Prehistory**. 2d ed. Anthropological Study Series #6. Baton Rouge: Department of Culture, Recreation, and Tourism, 1993.
- Nobles, Connie. **Adventures in Classroom Archaeology**. Baton Rouge: Division of Archaeology, Office of Cultural Development, Department of Culture, Recreation, and Tourism, 1992.
- Scheele, William E. **The Mound Builders**. Cleveland: World Publishing, 1960.
- Searcy, Margaret Z. **Ikwa of the Mound-Builder Indians**. Gretna: Pelican Publishing, 1989.
- Shemie, Bonnie. **Mounds of Earth and Shell**. Plattsburgh: Tundra Books, 1993.
- Silverberg, Robert. **The Mound Builders**. Greenwich: New York Graphic Society, 1970.
- Spearing, Darwin. **Roadside Geology of Louisiana**. Missoula: Mountain Press Publishing, 1995.
- Squier, E. G. and Davis, E. H., edited and with an introduction by David J. Meltzer. **Ancient Monuments of the Mississippi Valley: Comprising the Results of Extensive Original Surveys and Explorations**. 1848. Reprint. Washington D. C.: Smithsonian Institution Press, 1998.
- York, Linda. **Poverty Point State Commemorative Area: A Teacher's Guide**. Epps: Poverty Point SCA, 1998.
- Webb, Clarence. **The Poverty Point Culture**. 2d ed. Geoscience and Man, vol. XVII. Baton Rouge: Louisiana State University School of Geoscience, 1982.

## Videos

- INTERpark. **Flint Knapping with Bruce Bradley, PhD**. VHS tape. 1991.
- PBS Video. **Myths and Moundbuilders**. VHS tape. Odyssey series. 1980.
- Wombat Film and Video. **Lost in Time**. VHS tape. 1990.
- Mysteries of the Millenniums: Prehistoric Louisiana Archaeology**. VHS tape. 1998.

## Louisiana Public Broadcasting Programs

Check with your media specialist or the LPB channel nearest you for broadcast schedules and additional programming.

### **Gumbo Island, Program 1.**

**The First Louisianians.** At Epps, children learn that an ancient Louisiana people built a large ceremonial mound shaped like a bird, and they learn how the early Indians cooked their meals.

### **Louisiana Parade II, Program 1.**

**Poverty Point.** Poverty Point in Northeast Louisiana is a rich archaeological treasure that teaches visitors how Native Americans lived hundreds of years ago.

### **A Taste of Louisiana with Chef John Folse and Company, Program 303.**

Guest: Dennis LaBatt, Office of State Parks Commemorative Area Manager at Poverty Point

Menu: Casserole of venison and squash pot roast squab with kumquats, Melange of vegetable casserole

## Slide Presentation

A Poverty Point slide presentation with audio tape may be borrowed from the Division of Archaeology. There is no charge, but the borrower must pay for return postage. Call 1-225-342-8170 for additional information and scheduling.

## Poverty Point Suitcase Exhibit

The Poverty Point Suitcase Exhibit is also available from the Division of Archaeology. This exhibit contains authentic artifacts, reproductions of artifacts, and educational material for both the teacher and students. It may be reserved for one school week. The Division of Archaeology will pay for sending the exhibit to your school, but you must pay for its return. Call 1-225-342-8170 for scheduling information.

## Internet

The Internet provides a wealth of information for student research and allows students to work with the technology tools of the future. However, the Internet is not monitored for accuracy, so do caution students about choosing research sites carefully. Internet web addresses are constantly changing and searches will yield new web sites daily. Encourage students to search for Poverty Point, mound, mound building, mound builder, National Park Service, atlatl, and flint knapping. The following web sites are excellent sources of information:

Louisiana State Division of Archaeology  
[www.crt.state.la.us/crt/ocd/arch/homepage/index.htm](http://www.crt.state.la.us/crt/ocd/arch/homepage/index.htm)

Poverty Point State Commemorative Area  
[www.crt.state.la.us/crt/parks/pvertypt.htm](http://www.crt.state.la.us/crt/parks/pvertypt.htm)

Prehistoric Mounds in the Lower Mississippi Valley  
[www.cr.nps.gov/seac/folder.htm](http://www.cr.nps.gov/seac/folder.htm)

Nile of the New World  
[www.cr.nps.gov/delta/index.htm](http://www.cr.nps.gov/delta/index.htm)

Ancient Architects of the Mississippi  
[www.cr.nps.gov/aad/feature/feature.htm](http://www.cr.nps.gov/aad/feature/feature.htm)

## Free Posters

The Division of Archaeology offers free posters to educators. There is a five poster prehistory set which includes Paleo-Indian, Meso-Indian, Poverty Point, Early Neo-Indian, and Late Neo-Indian. There are also posters on Archaeology Week, an annual archaeological extravaganza which is held throughout Louisiana every fall. Contact the Division of Archaeology at 1-225-342-8170.

## Poverty Point State Commemorative Area

The Office of State Parks personnel and the Station Archaeologist sponsor many programs designed for school children of all ages. Tours of the mounds and demonstrations of ancient tools are among the many fascinating things students may experience while visiting. Contact the site for further information:

Poverty Point State Commemorative Area  
P.O. Box 276  
Epps, Louisiana 71237  
Phone: 1-318-926-5492  
1-888-926-5492 (toll free)



Mound A











Division of Archaeology  
Office of Cultural Development

Department of Culture,  
Recreation and Tourism

State of Louisiana