

High-precision multicomponent borehole deformation monitoring

Michael T. Gladwin

Department of Physics, University of Queensland, St. Lucia, 4067, Australia

(Received 22 February 1984; accepted for publication 28 August 1984)

An instrument capable of deep borehole measurement of vector plane strain to 0.3 nstrain and tilt to 1.0 nrad has been developed for deployment in crustal deformation and earthquake prediction studies. The instrument has been deployed in California where shear strains dominate the deformation. The 125-mm-diam package is grouted in 175-mm boreholes at depths of approximately 200 m. The wall thickness and the grout thickness are chosen to match instrument strength to expected rock parameters. The instrument is capable of flat response from dc to 10 Hz on any single channel. The electronics package is stable to three parts in 10^8 over the temperature range 10 to 45° C. Reliable shear strain data is available immediately on installation when simple volume strain meters show only bond curing effects or thermal recovery signals.

INTRODUCTION

To date, earthquake prediction programs have been based almost exclusively on seismicity studies supplemented by observation of the deformation of the surface of the earth. Because the deformations involved are relatively small, and occur over extended time scales (except during the catastrophic failure of an actual earthquake event), instrument design for solid earth deformation monitoring requires exceptionally high resolution and long term stability. The resolution or sensitivity of the instrument is usually specified in terms of its strain sensitivity, where strain is defined as a change in length per unit length.

A clear product of the past 15 years of deformation monitoring in California is that results observed using short base line instruments at or near the surface (less than 20 m deep) are often in conflict by as much as a factor of 50 with measurements over long base line (about 10 to 30 km). Extensive refinements on the long base line (geodetic type) techniques have produced data which provide very firm upper limits on the large scale deformations, and which have become the standard against which short base line instruments are evaluated. Long base line data to date has been of high reliability, but of low resolution (typically 0.3 μ strain), and its usefulness severely limited by the fact that it is highly manpower intensive, making continuous monitoring impracticable. An exception would be the multicolor laser system developed by Slater *et al.*¹ which is the first long base line instrument capable of providing continuous data.

Most of the conflict of data from short base line strain and tilt instrumentation has now been clearly demonstrated to be caused not by actual instrument problems but by local instabilities near to the instrument sites, including atmospherically induced noise, movement of water table, chemical aging of surrounding soils, and other artifacts of the surface. It is now considered that short base line instrumentation will be significant for long term, high-resolution monitoring only when located at substantial depths in sealed boreholes (perhaps below 150 m).

The most extensively tested continuous borehole strain monitor is the Sacks-Evertson volume strain meter which has been in use for over 10 years.^{2,3} Modeling studies of

earthquake related stress fields indicate that for many cases, knowledge of the volume strain is sufficient to determine changes in stress in the earth which could produce precursor signals. Geodetic strain measurements, however, indicate that a large proportion of the significant strain accumulation in California, for example, is in simple shear, so that it would appear that a borehole instrument located at 200–300-m depth which was capable of resolving the strain components in the horizontal plane could be a valuable contribution to the prediction effort. This paper describes such an instrument—the borehole capacitance strain monitor (BCSM) which has previously been used in strain monitoring of underground pillars in hard rock mining applications,^{4–6} and which has recently been developed to higher sensitivity and applied to solid earth deformation monitoring in earthquake prediction studies.⁷ The instrument has a useful sensitivity of about 0.3 nstrain and a tilt sensitivity of about 1.0 nrad. Dynamic range is approximately 10^{-4} and linearity better than 0.004%.⁸ After curing, bond stability at the level of 1–3 μ strain per year has been verified by the success of the Sacks-Evertson instrument. Similar expansive grout implantation has been used, and the instrument thus provides a new dimension in continuous borehole deformation, monitoring particularly in simple shear environments where volume strain is minimal.

Two other vector strain meters have been reported more recently. The first⁹ is essentially a modification of the Sacks-Evertson volume strain meter in which three separate sensing volumes are incorporated into a single instrument package. The annular shaped sensing volume of the Sacks-Evertson instrument is divided into three regions oriented at 120°. The second¹⁰ is based on capacitance micrometry and appears still in the initial trial stages. Both instruments have demonstrated the advantage of shear strain monitoring.

I. TECHNICAL DISCUSSION

In its normal configuration the instrument consists of seven independent components, illustrated in Fig. 1. Three of these measure strain in a plane perpendicular to the axis of the instrument. A further two components measure tilt from

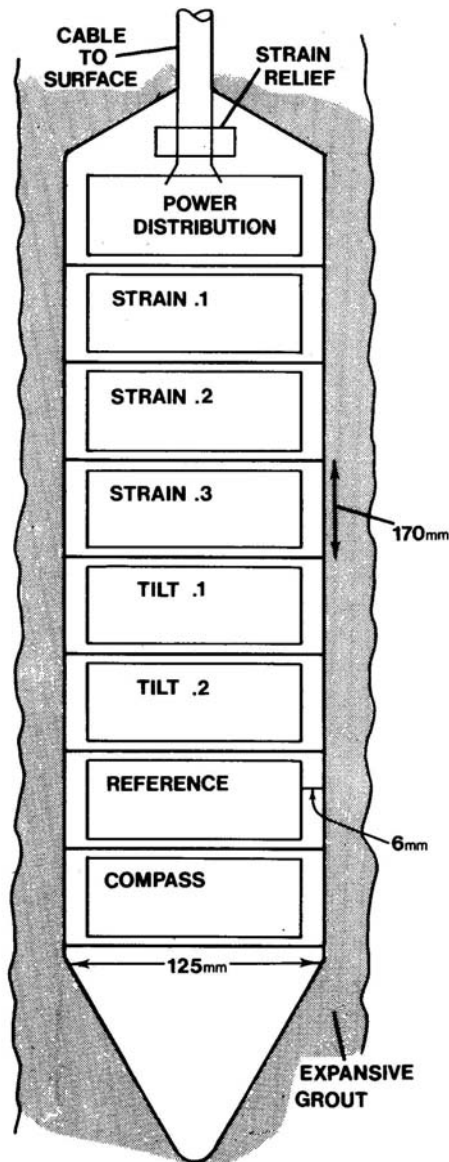

FIG. 1. Diagrammatic presentation of the complete downhole installation. Seven modules are included, three for plane strain, two for tilt, one for instrumentation monitoring, and one for orientation determination.

the axis of the instrument, one component measures the orientation of the instrument in the hole (either by magnetic or gyrocompass), and the final component is a nondeforming reference cell. Construction is modular, with each component approximately 170 mm in length. The modules are strain isolated by rigid bulkheads, and dimensioned such that within each module the strain field is transmitted to the transducer without perturbation. The outer diameter for all modules is 125 mm and the package is cemented into 175-mm-diam holes at a target depth of approximately 200 m using an expansive grout. The grout provides preload of the instrument to ensure that it remains in compression. Strain is monitored using the deformation of the instrument diameter; the three strain cells are aligned at 120° to each other. The nondeforming reference cell of identical layout and de-

sign is used to monitor the performance of the instrument cable and the surface electronics. At the level of precision and stability required, monitoring of the system itself becomes essential for long term precision. The final module contains the orientation device, which contains an optically encoded magnetic compass (optionally a gyrocompass) to determine the attained instrument orientation. It is not practical at the depths used to control the orientation of the device during deployment. An armoured cable (containing typically 12 twisted shielded pairs of conductors) is used as instrument support during deployment.

II. THE TRANSDUCERS

The sensing transducers are three element capacitances, with either a moving center plate (a pendulum or an equipotential surface) between two outer plates at fixed total separation (for tilt), or a moving outer plate with a fixed reference plate (for strain). The position of the moving plate can easily be monitored to 30 pm. Figure 2 shows a schematic drawing of a conceptual layout of a single strain component. Two plates of the three plate capacitor are mounted from one side of the instrument cylinder with a fixed and precisely ground interelectrode gap. The third plate, which in the case shown is the moving plate, is mounted from the opposite diameter. All plates are provided with fringing field guard rings and the reference gap is typically 0.5 mm. Thermal, mechanical, and electrostatic compensations are designed into the geometric configuration of the gauge sur-

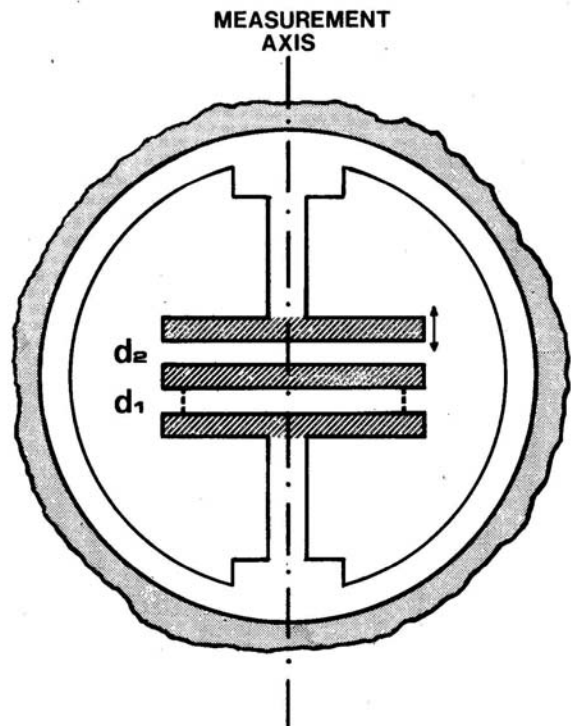

FIG. 2. Schematic cross section of a typical strain cell, which consists of a three element capacitance in which one plate gap is fixed as a system reference, and the other deforms with the cell walls. Wall thickness is usually in the range 3 to 6 mm. Tilt modules are configured with moving center plate.

faces. Three components of strain at 120° are monitored continuously on the assumption that along the axis of the instrument package (0.6 m) the strain ellipse is constant. This is achieved in practice by filling the hole with expanding grout for some meters above and below the instrument to produce a near homogenous inclusion. The device is normally designed to be "moderately hard" with an effective modulus of 0.6–0.8 of the host environment. The modulus of the instrument is determined by wall thickness and for most sites lies in the range of 1 to 10 GPa. Proper installation of a vector instrument requires core sampling of representative volumes to determine any anisotropy, to allow determination of *in situ* moduli, and to ensure that the instrument site is not contaminated by any local structural geologic features.

Deformations observed within the instrument are determined by its effective modulus (controlled by wall thickness and material), the moduli and thickness of the expansive grout, and the stress concentration around the borehole itself if the previous two control parameters are not exactly matched to the rock. A complete analysis allowing for the effects of the series of welded concentric rings of materials of different moduli following the techniques outlined by Savin,¹¹ Jaegar and Cook,¹² and Muskhelishvili¹³ shows that principal stress axes are preserved through the ring structure except in special cases, but the observed amplitudes can be perturbed significantly.¹⁴

For most applications, in particular where lack of information on the *in situ* moduli makes the more elegant solution irrelevant, an adequate analysis of the observed strains is obtained by assuming a single deforming ring welded to the rock. For three cells oriented at 120° from each other, and for the case of plane stress (as distinct from plane strain) here imposed by the lithostatic load along the borehole axis and the near free surface, the three gauges provide observed deformations of E_1, E_2, E_3 , which allow inversion of the three unknowns: change of hydrostatic strain (p), change of shear strain (s), and the angle from gauge 1 to the maximum principal strain axis (θ). It is shown¹⁴ that

$$p = A * (E_1 + E_2 + E_3) / 3, \quad (1)$$

$$\tan(2\theta) = \sqrt{3}(E_3 - E_2) / [(E_1 - E_2) + (E_1 - E_3)], \quad (2)$$

$$s = B * (E_3 - E_2) / (\sqrt{3} * \sin 2\theta), \quad (3)$$

TABLE I. Effective instrument scale factors for present design parameters in different host environments.

Rock Youngs Modulus (GPa)	A	B
1	10.00	0.50
3	3.57	0.43
6	1.92	0.41
10	1.30	0.40
15	0.99	0.39
30	0.67	0.36

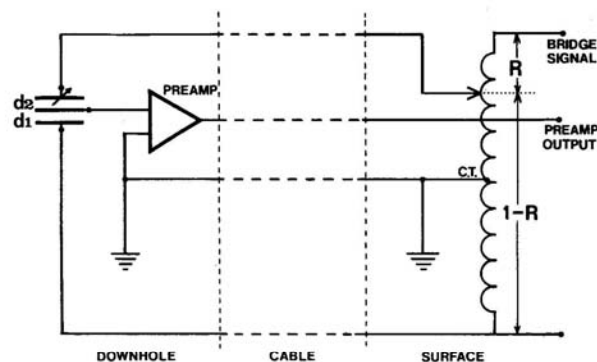

FIG. 3. The ratio transformer bridge is configured with the capacitance ratio components downhole, and the ratio transformer and all signal conditioning electronics at the surface.

where A (the hydrostatic strain scaling factor) and B (the shear strain scaling factor) are dimensionless constants for the gauge in its rock environment. The values of A and B are computed from the moduli of the rock and the instrument, and the wall thickness and radius of the instrument. Typical values are shown in Table I for the gauge parameters used. The requirement that the gauge be properly matched is obvious, and in particular, to retain optimal signal-to-noise ratios on the measured deformations, the value of A should not be too large. The values of A and B are not strongly dependant on the value of Poissons ratio. The coefficient B is relatively constant in this single ring approximation but is in fact strongly dependent on the moduli of the grout in a full analysis. When required, the hydrostatic stress change and the shear stress change can be computed from p and s using the elastic moduli of the rock.

Vector tilt of the instrument axis is determined by the use of two orthogonal components. Tilt components are also measured using three plate capacitors using either a mercury tilt meter of basic design used by Stacey *et al.*,¹⁵ miniaturized to 100-mm base line, or a simple pendulum. Either case includes a leveling device with dynamic range of 10° to permit the tilt meter to be leveled *in situ* after the grout has hardened, since boreholes are commonly several degrees from the vertical. The leveler is disabled after use, since all subsequent tilts are less than 100 μ rad, which is well within the linear range of the transducers.

A nondeforming cell of identical size as the strain cell transducers is included in the instrument to allow accurate monitoring of any spurious signals produced by changes in the physical properties of the cables or total measurement system. A further performance diagnostic is obtained by continuous monitoring of the temperature at various positions in the instrument.

A major consideration in the design of such an instrument is long-term stability. The stability of the mechanical components can be controlled by choice of materials, fabrication procedures, and thermal destressing of the completed transducer. The electronic stability of the instrument is achieved by the use of a ratio transformer bridge as developed by Thompson,¹⁶ Jones,¹⁷ Stacey *et al.*,¹⁵ and Gladwin and Wolfe.⁸ The measurement of differential capacitances with these techniques can be achieved to the stability of the

passive voltage division of the ratio transformer itself. To minimize the complexity of the nonretrievable downhole device, the capacitance bridge is divided in the manner illustrated in Fig. 3. For each component the downhole device consists only of a phase stable impedance matching preamplifier, and isolated regulated power supply. In the present instrument a five decade transformer is used, supplemented by three decade digits of out-of-balance analog-to-digital conversion. Stability and linearity at the 0.1% level is thus adequate at the final analog stage of the measurement. Environmental stability of the ratio transformer is better than 2 parts in 10^9 per degree Celsius. The total electronics is stable to 3 parts in 10^8 over the temperature range 10° to 45° C.

Referring to Fig. 3, for a five-digit decade transformer reading R (taken as a number between 0 and 0.5), the fraction of the bridge voltage which appears across the two downhole components $C1$ (with plate separation $D1$) and $C2$ (with plate separation $D2$, $D2 < D1$ in this configuration) is $(1 - R) \cdot C1$. $C1$ is a fixed capacitance used as a reference and $C2$ is deformation dependent. For this configuration with a moving outer plate and the transformer center-tap grounded, bridge balance occurs when

$$(0.5 - R) / 0.5 = D2 / D1, \quad (4)$$

or

$$D1 - D2 = \Delta D = R \cdot (D1 / 0.5). \quad (5)$$

Thus, the movement (ΔD) of the deforming plate from an image plane at $D1$, ($D1 - D2$), is monitored linearly by the ratio (measured to 1 in 10^5) R which, augmented by the analog measurement, can be resolved to 1 in 10^8 . The fixed distance $D1$ is approximately 0.5 mm so that changes of the absolute position of the moving plate are resolved to 10 μ m. In practice, amplifier short term drift between automatic recalibrations limits the measurement accuracy to 30 μ m. With an instrument diameter of 125 mm, the mechanical gain permits strain measurement at better than 0.3 nstrain. For the tilt case, a moving center plate is used, and reconfiguration of the bridge electronics also results in a linear response.

Operation of the instrument is controlled by a microprocessor (RCA 1802), which sequences the various trans-

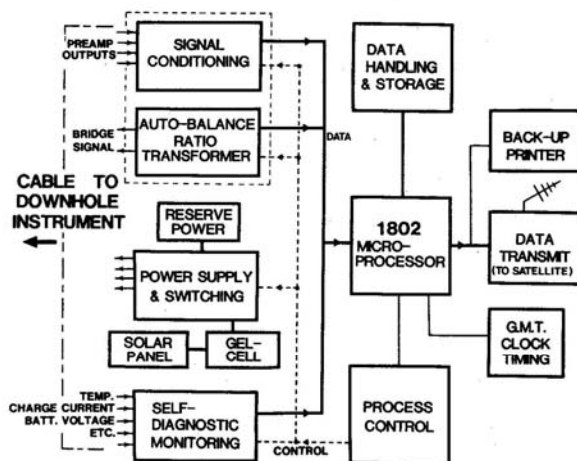

FIG. 4. Layout for the complete monitoring instrument. Control is from the microprocessor, and the data stream is rich in self-diagnostics. The prime data pathway is via a satellite link, but a backup printer is included.

ducers through electronics common to all sensors. After each sweep of displacement measurements, gain and dc offsets for each channel are measured separately. These parameters are then used in the production of a high-stability measurement of the position of each moving element. The system layout is illustrated in Fig. 4. The channel under sample is selected by the microprocessor and the previous balance condition is applied to the ratio transformer. The balance condition is then corrected as necessary for exact balance at the preselected gain and time constants. An eight digit balance value is produced and stored for later transmission. For each channel the dynamic gain is then measured by application to the ratio transformer of an applied and precisely known offset, which is then measured as if it were signal. Correction constants for dc amplifier drifts are checked and incorporated into the final measured value. After each group of readings a series of self-diagnostics are applied to the instrument package to monitor any variations of temperature, reference frequencies, and power supply voltages. These diagnostics, together with the dynamic gain coefficients and offset drift estimates, are included in the final

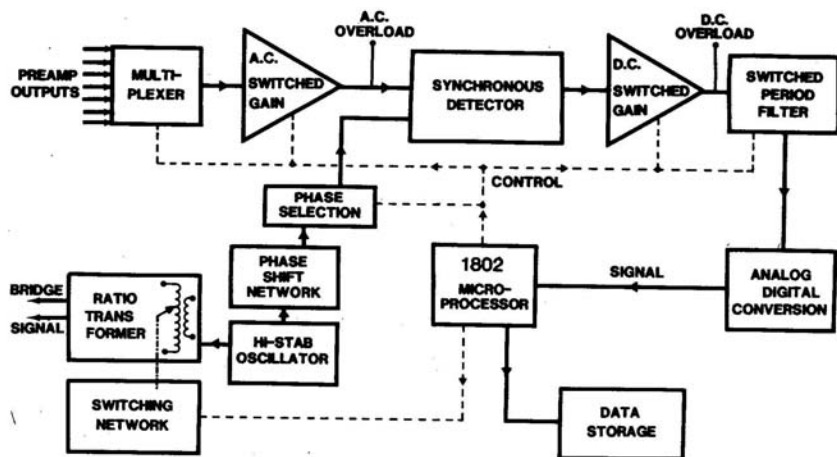

FIG. 5. Detail of the self-balancing bridge electronics. The various transducer modules are multiplexed into a switched-gain ac amplifier before measurement in a synchronous detector which used switched dc gain and controllable time constants. The out of balance signal is used to servo the ratio transformer for each channel using the previous balance reading as starting point. When proper balance is attained, the reading is corrected for variations in gain and dc offset, and stored for later transmission.

data stream which in California is transmitted every 3 h via a satellite link to a data retrieval center at Menlo Park, California. Selected data is also printed with an on site thermal printer. Design emphasis has been placed on low maintenance cycles, with diagnostics which provide an indication of potential instrument failure in sufficient time to allow repair before loss of data. The site operates on a single maintenance visit per year. Power is provided from a single 30-W solar panel, charging a gel cell (40 A H). Default shutdown procedures are programmed into the software in the event of shortage of reserve power. The instrument also has a set of 1000 A H Carbonaire cells, which can be used as reserve power for 3 to 4 months.

Figure 5 shows some detail of the auto balancing bridge electronics (the dotted region of Fig. 4), which is essentially a synchronous amplifier, with variable gain and variable integration time constants. Stability and performance of the electronics have been verified by measurements against standard ratio transformers, and the observed ratio is good to three parts in the eighth decade for the temperature range 10 to 45° C. This is equivalent to a strain stability of approximately 50 pstrain/°C. The internal offsets and calibration procedures allow correction for thermally induced errors. The strain monitoring system in its present configuration is multiplexed over seven channels. It is possible to operate any channel in a continuous mode in which response is flat from dc to 10 Hz where the dynamic range of the singles remains less than 60 dB. Tests of the instrument as a vector strain seismometer operating at a sensitivity of 10 pstrain are in progress.

III. RESULTS

An instrument was recently installed at the Pinon Flat Observatory of the University of California at San Diego. The instrument location was chosen for direct comparison of the strain measurements with both the long base line interferometer spanning the site,^{18,19} and with a group of three DTM Carnegie Institution of Washington Sacks-Everton strain meters within 300 m. Installation at depth 151 m in competent granite was completed 16 September 1983. Relative to true north, the axis of gauge 1 was at 5° west, with gauge 2 at 65° east, and gauge 3 at 125° east. The instrument hole was grouted to the surface to minimize thermoelastic contamination by circulation of groundwater. Installation procedures were essentially the same as developed by the DTM group for the volume strain meters, in particular, in the choice of grout. This permits direct comparison of performance between the instruments.

Figure 6 shows a typical sample of the data taken soon after installation when the whole instrument was undergoing volumetric compression due to the curing of the grout. It demonstrates excellent resolution of the solid earth tides which in this location have an amplitude of about 0.025 μ strain. A simple exponential compression caused by the curing of the grout has been removed from the data. The phase shown on G2 which is almost north south agrees well with that recorded on an adjacent long base line interferometer (Wyatt, private communication). In the absence of core

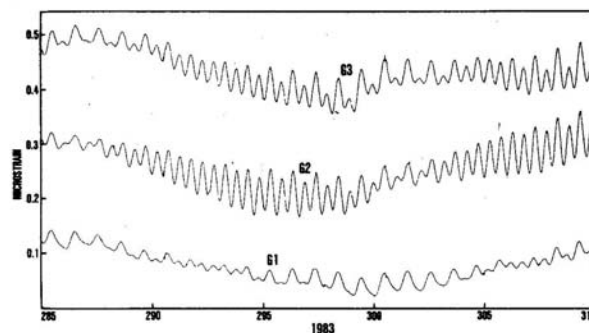

FIG. 6. Raw tidal records 4 weeks after installation at the Pinon Flat site. A simple exponential has been subtracted to detrend the data.

samples at the instrument site, it will be necessary to determine instrument calibration by direct reference to the IGPP instruments. This calibration will be carried out when the grout, which controls instrument mechanical gain, has stabilized in approximately 6 months. The scale on Fig. 6 is calculated from instrument geometry alone and indicate a tidal amplitude approximately 50% larger than the long base line interferometers, indicating that the instrument implant is somewhat softer than its surroundings. The calibration will permit an estimate of the modulus ratio for the instrument implant and the host rock.

The results presented here are intended only as an illustration of the potential significance of the present instrument in monitoring vector plane strain data. The instrument has a wide range of potential uses where high-resolution vector deformation monitoring is required. It is especially valuable in the isolation of geophysically significant signals in the presence of normal hydrostatic noise sources, such as fluctuations in water tables, atmospheric loadings, and seasonal thermoelastic effects, which cannot in principle be distinguished by simple volumetric instruments. Further, a pair of instruments at appropriate separation can be used in the manner outlined by Wyatt²⁰ for static determination of fault parameters. It can also be used in deep foundation monitoring, and it has already been used in high load structural monitoring. The excellent long-term stability, and the intrinsic redundancy of the instrument, in particular in its complete form with two axis tilt components, give it considerable appeal for downhole studies where much of the expense is involved in site preparation.

ACKNOWLEDGMENTS

Early developments of the instrument were supported by the Australian Research Grants Committee. The work described here was supported by the United States Department of the Interior, Geological Survey. Site preparation and logging was performed by Dr. J. Healy's group from the U.S.G.S, and the assistance of R. Mueller and D. Myren during the installation is gratefully acknowledged. Dr. F. Wyatt of IGPP provided valuable support at the Pinon installation and with information on performance of UCSD instrumentation. Dr. A. T. Linde contributed significantly by detailed information on the techniques used by DTM,

much of the support hardware, and well distilled insights on the problems of such installations. Data retrieval has been provided through Dr. M. Johnston, K. Breckenridge, and S. Silverman of the U.S.G.S. The equipment deployed in the USA was fabricated in Department of Physics mechanical workshops. The contribution of my own research staff, R. Hart, M. Francis, R. Gwyther, and F. Peters in the production of the instrument is acknowledged as particularly significant to the quality and reliability of the instrument. Components of the instrument are the subjects of various patents and applications.

¹L. E. Slater and G. R. Huggett, *J. Geophys. Res.* **81**, 6299 (1976).

²I. S. Sacks, S. Suyehiro, D. W. Evertson, and Y. Yamagishi, *Pap. Meteorol. Geophys.* **22**, 195 (1971).

³F. Wyatt, D. C. Agnew, A. Linde, and I. S. Sacks, *Carnegie Institution of Washington Year Book* **82**, pp. 533-38.

⁴M. T. Gladwin, *EOS (Trans.) A.G.U.* **54**, 1192 (1974).

⁵M. T. Gladwin, *Pure Appl. Geophys.* **115**, 267, (1977).

⁶M. T. Gladwin, *Int. J. Rock Mech. Min. Sci.* **19**, 221 (1982).

⁷M. T. Gladwin (submitted for publication).

⁸M. T. Gladwin and J. Wolfe, *J. Sci. Instrum.* **46**, 1099 (1975).

⁹S. Sakata, S. Shimada, and S. Moguchi (in press).

¹⁰Shun-liang Chi, *Acta. Seismol. Sinica* **4**, 98 (1982).

¹¹G. N. Savin, *Stress Concentration Around Holes* (Pergamon, New York, 1961), Chap. 5, translated by W. Johnson.

¹²J. C. Jaeger and N. G. W. Cook, *Fundamentals of Rock Mechanics*, 2nd ed. (Chapman and Hall, London, 1976), Sec. 10.4.

¹³N. I. Muskhelishvili, *Some Basic Problems of the Mathematical Theory of Elasticity* (P. Noordhoff, Groningen, Holland, 1953), translated by J. R. M. Radok.

¹⁴M. T. Gladwin (submitted for publication).

¹⁵F. D. Stacey, J. M. W. Rynn, E. C. Little, and C. Croskell, *J. Phys. E* **2**, 945 (1969).

¹⁶A. M. Thompson, *IRE Trans. Instrum.* **I-7**, 245 (1958).

¹⁷R. V. Jones, *Phys. Bull.* **18**, 325 (1967).

¹⁸F. Wyatt, *J. Geophys. Res.* **87**, 979 (1982).

¹⁹J. Berger and R. H. Lovberg, *Science* **170**, 296 (1970).

²⁰F. Wyatt, *Trans. Am. Geophys.* **61**, 221 (1980).