

CN 041

This document is made available electronically by the Minnesota Legislative Reference Library  
as part of an ongoing digital archiving project. <http://www.leg.state.mn.us/lrl/lrl.asp>

REGIONAL COPPER-NICKEL STUDY

PRELIMINARY  
SUBJECT TO REVIEW

Field Studies: Leaching, Metal Transport  
and Metal Pathways

Progress Report

February 1, 1977

Paul Eger  
Bruce Johnson  
Peder Otterson

This report presents the available data that have been collected by the leaching/pathways program. In all the areas discussed, additional sampling has been conducted, but results are not yet available. All conclusions and interpretations are to be considered preliminary. In an attempt to illustrate the approach and the models being considered, limited data have often been used to show trends and indicate possible mechanisms. It must be understood that statements made on the basis of limited data are subject to change.

Signed,

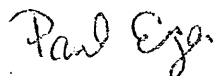
A handwritten signature in cursive script that reads "Paul Eger".

Paul Eger

## CONTENTS

	<u>Page</u>
Overview	1
Geology	2
Description of Study Area	2
Topography	8
Glacial Processes	8
Hydrogeology	10
Methods	11
Surface Water-Unnamed Creek	11
Surface Water-Bob Bay, Dunka Bay	11
Materials and Methods in Groundwater Sampling	11
Erie Wells	11
Piezometers	17
Surface Sampling Wells	17
Peat Samples	19
Results and Discussion	23
Erie Wells	23
Water Levels	23
Chemical Data	26
Bog Study	29
Unnamed Creek	33
Hydrology	33
Water Quality	37
General Discussion Unnamed Creek Chemistry	44
Seeps	44
EM-9	47
Plans	55
Seep 3	55
Seep 2	61
Seep 1	61
Summary-Seeps-Field Leaching	64
Transport	66
Metal Forms	85
Bob Bay-Dunka Bay	88
Interpretation of Data	89
Sediment Study	89
Water Chemistry	89
Bioassay	90
US Steel-Bulk Sample Site	93
Minnamax	97
Future Plans-Summary	100

## FIGURES

	<u>Page</u>
Fig. 1	3
Fig. 2	4
Fig. 3	5
Fig. 4	9
Fig. 5	12
Fig. 6	14
Fig. 7	15
Fig. 8	16
Fig. 9	18
Fig.10	21
Fig.11	22
Fig.12	25
Groundwater contours (ft,msl), Erie Mining Co., 8011 Waste Rock Stockpile, 18 October 1976.	25
Fig.13	31
Specific conductance & temperature, Erie Bog, 7 Oct. 1976	31
Fig.14	34
Representative stream hydrographs	34
Fig.15	36
Mean daily flow, EM-1 & EM-3, July-September, 1976	36
Fig.16	41
Hydrographs at time of sampling, July-August, 1976	41
Fig.17	42
Hydrographs at time of sampling, September, 1976	42
Fig.18	46
Streams receiving mine dewatering discharges	46
Fig.19	49
Generalized cross-section, 8011 Stockpile	49
Fig.20	50
Proposed groundwater flow conditions, 8011 Stockpile	50
Fig.21	52
Original drainage, 8011 Stockpile	52
Fig.22	53
Sulfate vs. 1/discharge EM-8	53
Fig.23	54
Nickel vs. 1/discharge EM-8	54
Fig.24	56
Gabbro Stockpile 8014	56
Fig.25	58
Gabbro Stockpile 8014	58
Fig.26	59
Gabbro Stockpile 8014; Waste Rock Stockpile 8011	59
Fig.27	60
EM Seep 3 discharge vs. time	60
Fig.28	62
Waste Rock Stockpile 8013	62
Fig.29	63
Original topography in vicinity of Seep 1	63
Fig.30	65
Nickel vs. time EM Seep 1	65
Fig.31	67
Copper loading	67
Fig.32	68
Nickel loading	68
Fig.33	69
Zinc loading	69
Fig.34	70
Input-output model	70
Fig.35	73
Nickel loading-Unnamed Creek, 7/15/76	73
Fig.36	74
Nickel loading-Unnamed Creek, 7/27/76	74
Fig.37	75
Nickel loading-Unnamed Creek, 8/12/76	75
Fig.38	76
Nickel loading-Unnamed Creek, 8/26/76	76
Fig.39	77
Nickel loading-Unnamed Creek, 9/8/76	77
Fig.40	78
Nickel loading-Unnamed Creek, 9/21/76	78
Fig.41	79
Calcium loads lbs/day-Unnamed Creek, 8/12/76	79
Fig.42	80
Chloride loads-Unnamed Creek, 8/12/76	80
Fig.43	81
Sulfate loads-Unnamed Creek, 8/12/76	81
Fig.43a	81a.
Copper load, 8/12/76	81a.
Fig.44	96
U.S. Steel Bulk Sample Pit	96
Fig.45	98
Multilevel well	98

## TABLES

		<u>Page</u>
Table I	Field study areas	6
Table II	Stockpile composition, area Eight-Dunka Pit	7
Table III	Average chemical concentrations: seepages	13
Table IV	Water table elevations (ft. ms1), Dunka Pit stockpile wells	26
Table V	Specific conductance of Erie Wells, Dunka Pit	27
Table VI	Well water chemistry, Erie Mining Co., Dunka Pit October 18, 1976	-
Table VII	Peat stratigraphy, location 3-4	30
Table VIII	Ultracentrifuge experiment (R.S. Rosich and P.H. Otterson, 1976)	32
Table IX	Mean daily flow, Unnamed Creek, September 11-15, 1976	35
Table X	Average concentrations 011, 012 discharge	38
Table XI	Water quality data, Unnamed Creek, Station EM-6	39
Table XII	Comparison of water quality; EM-6 & EM-1	43
Table XIII	Water quality comparison	45
Table XIV	Comparison of EM-8 & EM-9	51
Table XV	Stream loading of nickel as determined by segment	82
Table XVI	Stream loading, calcium, chloride, sulfate, 8/12/76	84
Table XVII	Copper complexing capacity & differential pulse polarographic analysis of Unnamed Creek samples	86
Table XVIII	Ultracentrifuge experiment (R.S. Rosich & P.H. Otterson, 1976)	86
Table XIX	Sample site: Dunka Bay; Bob Bay, 8/27/76	91
Table XX	Sample site: Dunka Bay; Bob Bay, 8/31/76	92
Table XXI	Water quality data, US Steel	94

The interrelationships between the various portions of this program are shown schematically in Figure 1. The individual field projects are listed in Table I and shown in Figure 2. The major effort this year has been at Erie Mining Company's Dunka Pit. This area will continue to receive a major emphasis, but more work will be conducted at AMAX and US Steel next year. Some work may be done at the Inco bulk sample site this spring. An outline of next season's field plans will be available by March 31.

### Erie Mining Company-Dunka Pit Study

#### GEOLOGY

##### Description of Study Area

The Dunka Pit (Erie Mining Company Area 8) is located in the northwest quarter of the USGS Babbitt NE Quadrangle, 7.5 minute series, 1969 (Figure 2). Immediately north of the pit lies Birch Lake. Dunka Pit is approximately 2.5 miles long, .25 mile wide and 350 feet deep. The pit follows the strike of the Iron Formation (N 30 E). The Iron Formation dips to the southeast underneath the basal mineralized zone of the Duluth Gabbro Complex.

Erie Mining Company mines taconite from the Iron Formation at the Dunka Pit and transports it to their Hoyt Lakes Plant where it is processed along with lower grade ore. The stripped overburden is segregated by rock type--lean ore, waste rock and mineralized gabbro (enriched in metal sulfides). Stockpiling of the sulfide-rich gabbro began in 1967. The combined weight of the three gabbro stockpiles now equals approximately six million tons. In addition, there are some 23 million tons of rock classified as "waste rock stockpiles" with an estimated composition of 70 percent gabbro (Figure 3, Table II).

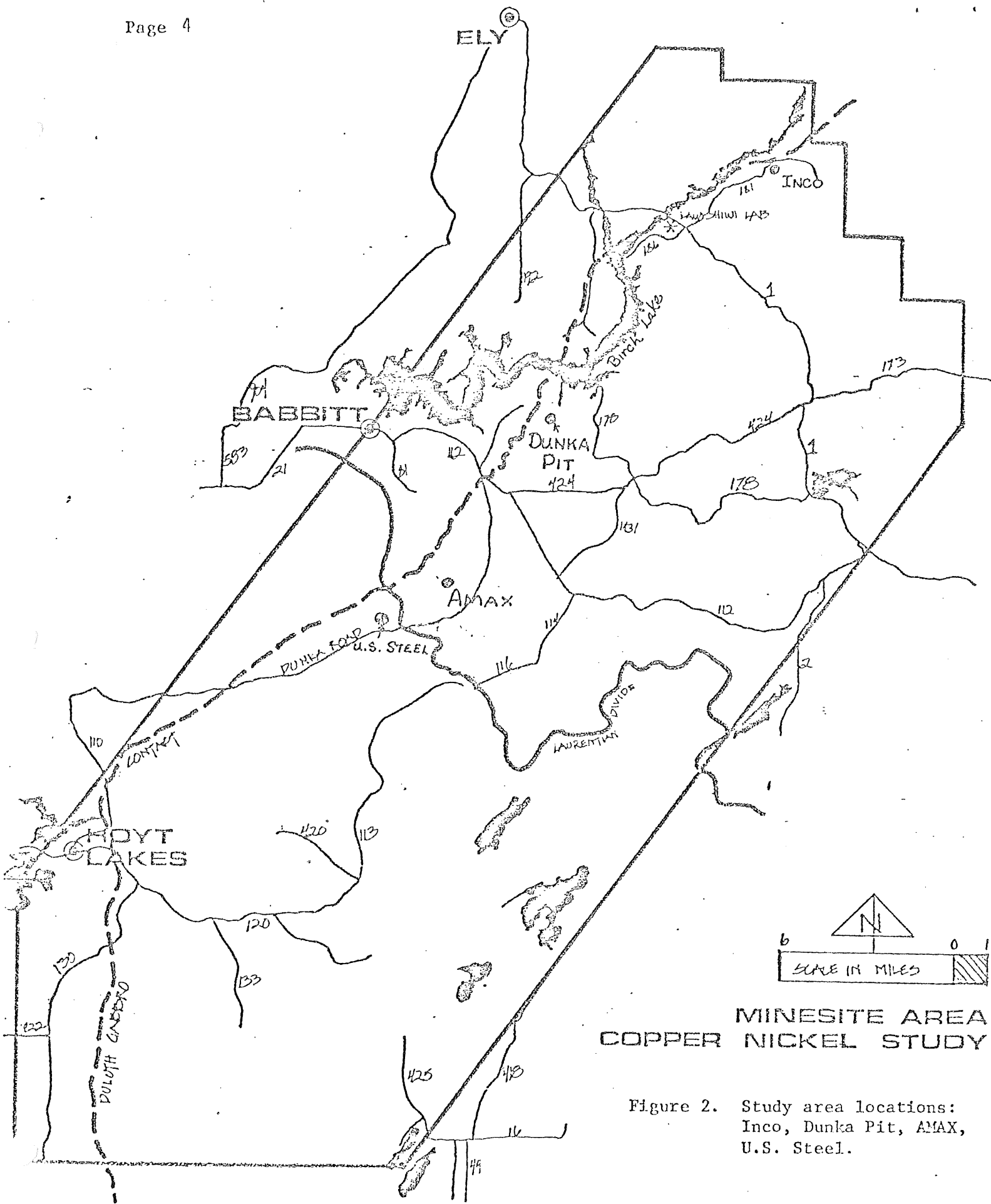

### MINESITE AREA COPPER NICKEL STUDY

Figure 2. Study area locations:  
Inco, Dunka Pit, AMAX,  
U.S. Steel.

Table I. Field study areas.

<u>Location</u>	<u>Study</u>	<u>Objective</u>	<u>Goal</u>	<u>Description</u>	<u>Plans</u>
1. Erie Mining Co. and Dunka Pit	a. Field Leaching	measure rates of metal release under actual field conditions	What is the extent & rate of release of heavy metals from stockpiles?	Three distinct seeps have been identified; measure quality and quantity as a function of time	intensify sampling to obtain better release information; attempt tracer studies to pinpoint seep sources
	b. Bog	measure transport of leachate through a bog	What is the rate and extent of heavy metal transport through a bog?	Leachate flows directly into a white cedar-alder bog. Measure loading into bog and concentration of metals in water and peat.	winter sampling of bog drainage to measure release analysis of peat core samples collected last summer intensive spring sampling to measure any flushing action
	c. Unnamed Creek	measure transport of heavy metals in a stream	What is the transport of heavy metals in a stream system?	Leachate enters Unnamed Creek in several areas measure quality and quantity as a function of time and location	winter sample under stable flow conditions intensive sampling for a short period of time during open water stable conditions
	d. Bob Bay	measure loading to bay, transport through bay and accumulation	What is the fate of heavy metals in the discharge?	Unnamed Creek is only major flow to Bob Bay. Measure input from creek concentration in water and sediment in bay.	winter sampling of bay sediment sampling this winter continue sampling this year
2. US Steel	Field Leaching	measure rates of metal release under actual field conditions	What is the extent & rate of release of heavy metals	small confined basin: inflow is from runoff & precipitation/ outflow due to evaporation & seepage; measure quality and depth as a function of time	intensify sampling to obtain release information
3. AMAX	a. Field Leaching	measure rates of metal release under actual field conditions	What is the extent & rate of release of heavy metals from stockpiles?	1. waste rock pad-multilevel well has been installed within the pad to determine leaching and movement of leachate	installed in November sampling has begun
				2. test piles-lean ore piles constructed on an impermeable base	sample intensively during runoff events
	b. Bog	measure transport of leachate through a bog	What is the rate & extent of heavy metal transport through a bog?	waste rock pile is built in a black spruce bog, all seepage from the settling basins and the site runoff flows into the bog	intensive spring sampling to determine flush



### Topography

The land rises southwest of Dunka Pit culminating in the topographic high known as the Giants Range. East of the pit, the landscape consists of a series of linear bedrock ridges striking N 30 E. This strike is the same as that of the bedrock outcrop in the pit and of a major fracture pattern in the bedrock.

Immediately south of the pit, a terminal moraine trends east-west. The moraine cuts across the northern quarter of a broad, flat, boggy depression. The Dunka River flows along the western margin of this depression, turns abruptly west where it encounters the moraine, and enters Birch Lake approximately one mile west of Dunka Pit.

### Glacial Processes

Glacial advances during the Pleistocene obliterated some bedrock features and enhanced others. Weak zones in the bedrock created by the fracture patterns were gouged out by the advancing wall of ice leaving a series of elongate valleys. Multiple glacial advances and retreats occurred. Rock debris picked up by the ice was either deposited at the terminus of the ice advance in a hilly terminal moraine or behind the terminus in rolling ground moraine. Meltwater from the wasting ice reworked some of the glacial drift, sorted it, and deposited it in broad aprons of outwash sands and gravels. Glacial drift and outwash filled in many of the bedrock depressions masking bedrock topography and creating buried valleys.

The terminal moraine south of Dunka Pit appears to lie upon a broad deposit of outwash that was formed during an earlier glacial retreat. A series of six test wells located around the 8011 Waste Rock Pile show that some of the bedrock valleys have been filled by this outwash deposit (Figure 4). Well 24

lies over a valley that is filled with outwash overlain by a thin veneer of till and peat. The trend of the valley is presumably that of the region (N 30 E). If so, at least some of the outwash extends beneath the stockpile. The outwash deposit is believed to be contiguous with the large outwash deposit that is found south of the moraine. Another tongue of this outwash deposit occurs in a buried valley that has been transected by the south pit of the Dunka Mine. The outwash appears to pinch out to the north where till replaces outwash in the valley fill (Wells 26 and 27). Wells 22 and 23 indicate that the valley west of Well 24 is filled with till.

Since the last glacial retreat approximately 10,000 years ago, insufficient time has occurred for the streams to adjust to the region. Drainage patterns are deranged and many enclosed or poorly-drained depressions exist. Stagnant or slow-moving water in these depressions has prevented the oxidation of organic plant debris allowing it to accumulate to form peat deposits.

#### Hydrogeology

Because of its massive, crystalline nature, the bedrock yields little water except where extensive joints and fractures exist. Test holes drilled into the bedrock occasionally yield highly saline water, but the yield is low and occurrence is rare. Except for the geochemical implications as to its origin, such water should be of little consequence to future mining operations.

Of the surface materials, only the outwash deposit is a good aquifer. Springs trickle from it on the south wall of Dunka Pit and form a pond at the base of the pit. Because of the close proximity of Dunka River to the pit, it is possible that the river may contribute to the flow in the springs via recharge into the outwash.

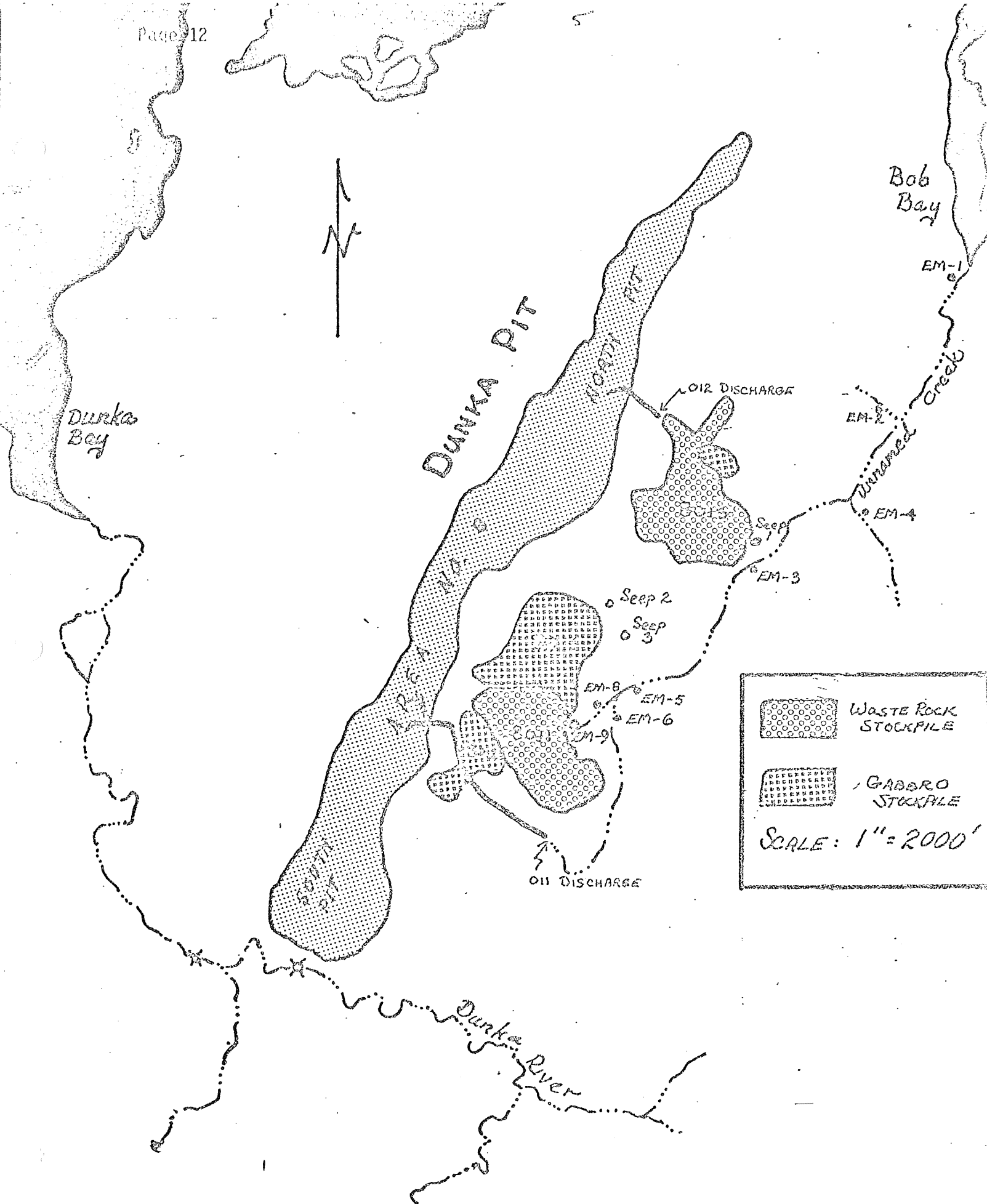
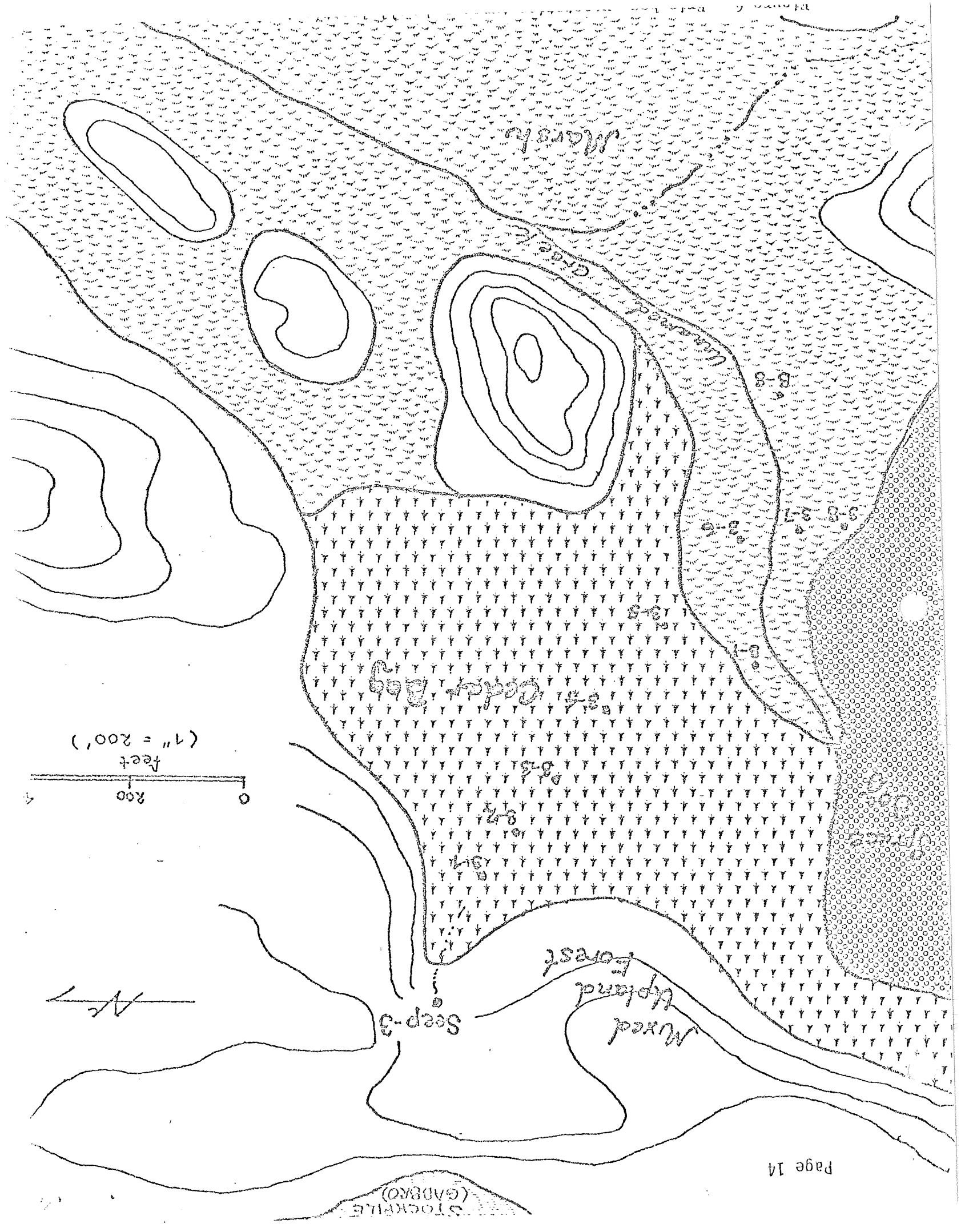

Figure 5. Location of seeps - Dunka Pit.



Marsh

Cedar Bog

Mixed Wood Forest

Seep-3

STOCKPILE (GABRO)

(1" = 200')

feet

200

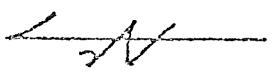

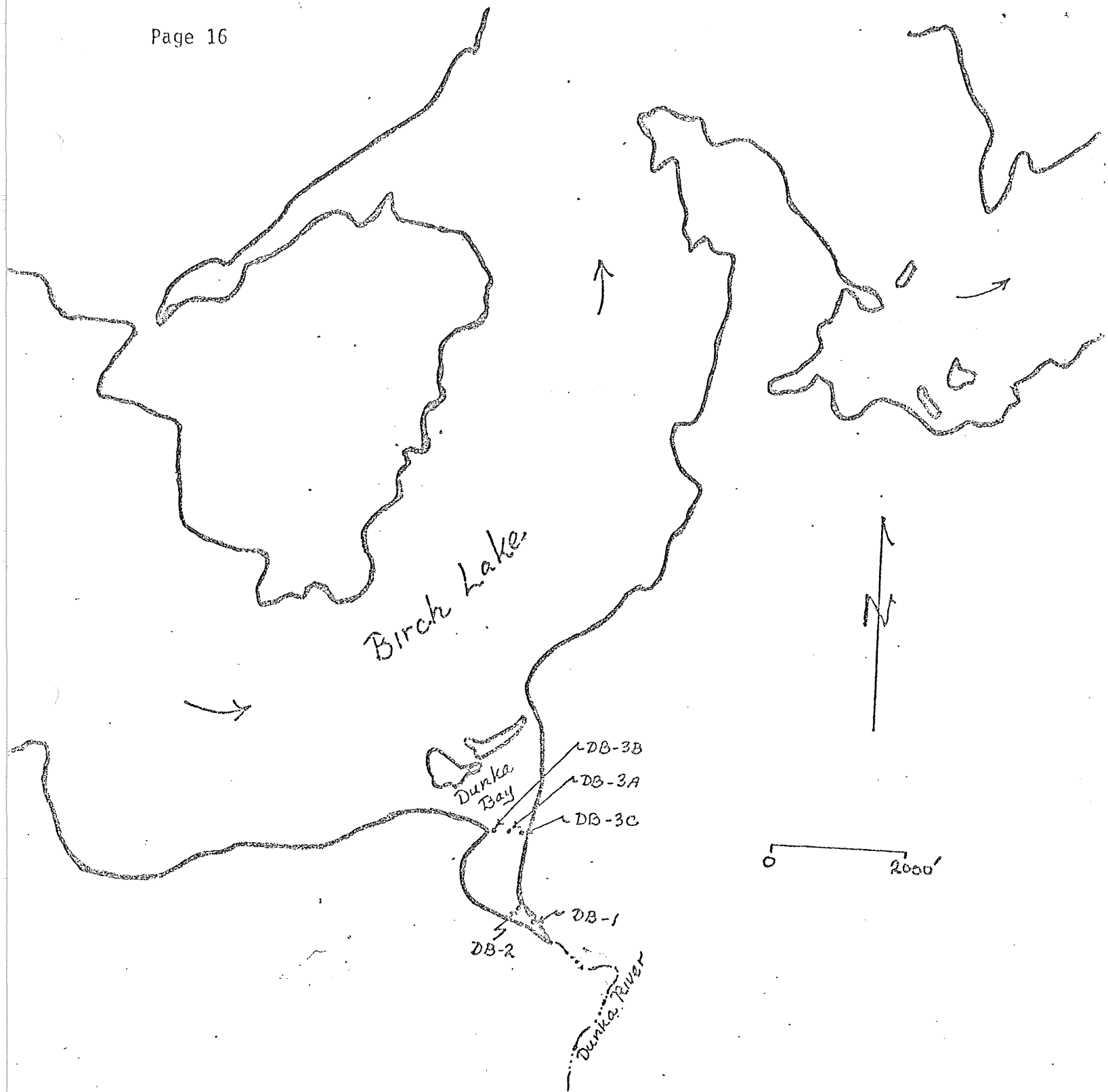

Figure 8. Dunka Bay sampling sites.

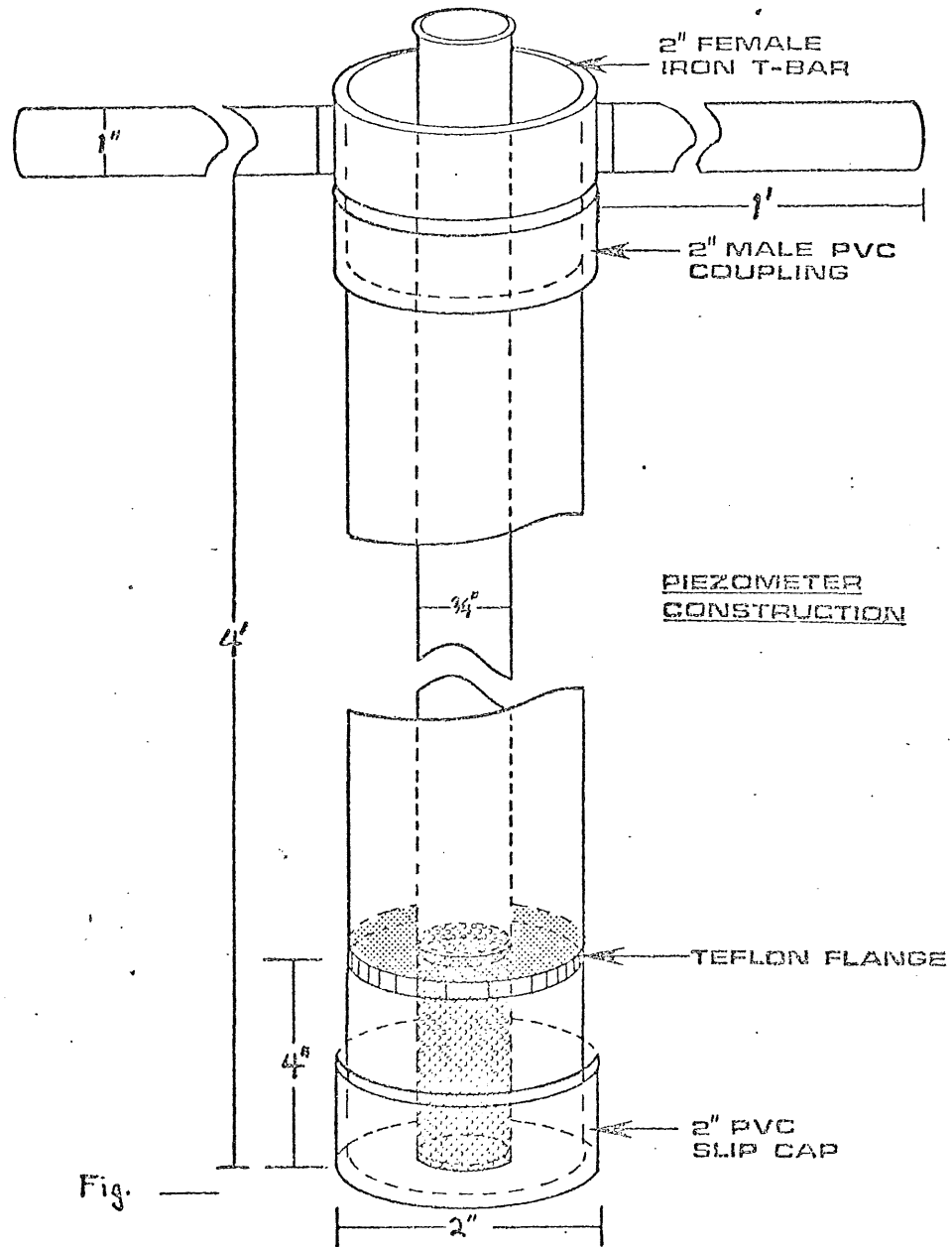

Figure 9. Piezometer construction.

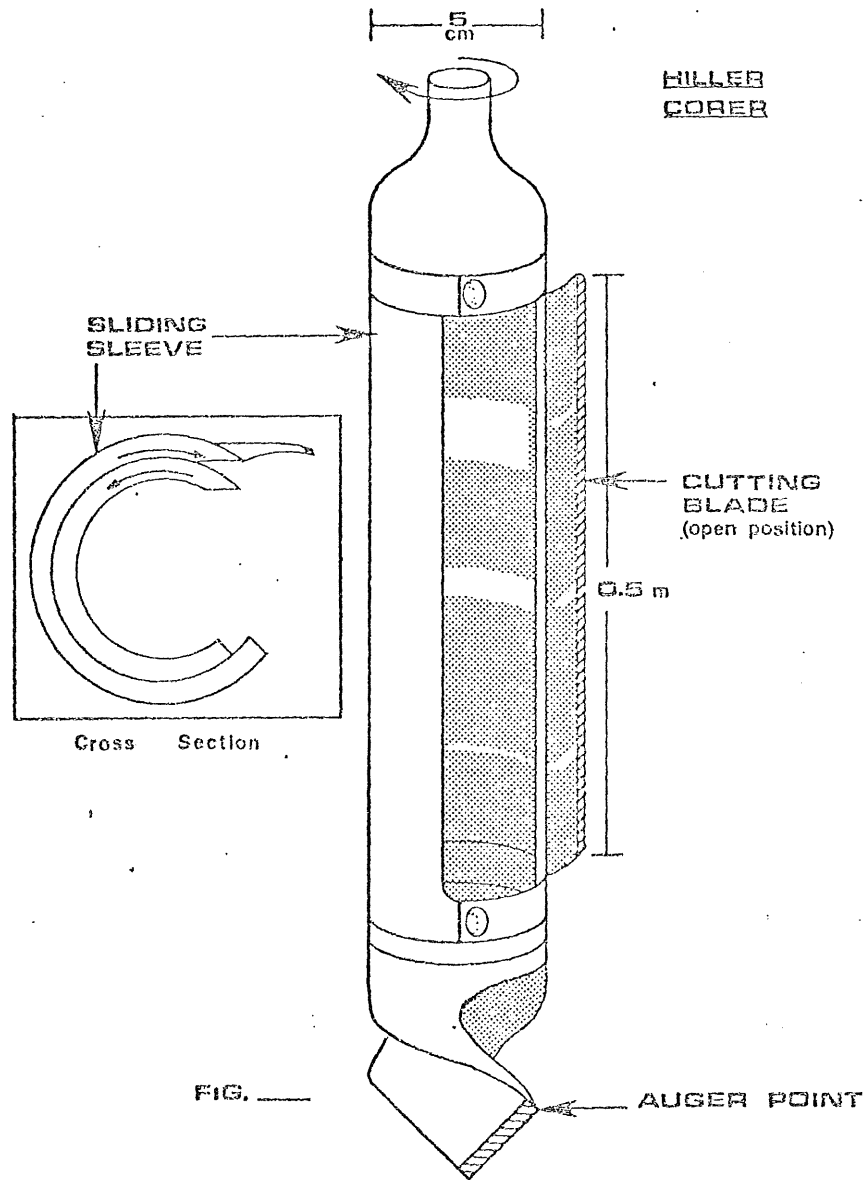

Figure 10. Hiller Corer.

The cores are preserved for later chemical analysis by sealing them in nitrogen/helium-purged packages of a special oxygen scavenging material that was supplied courtesy of American Can Company. The sealed cores are then stored in a vertical position in the cool room of the Bell Museum, University of Minnesota.

Special care has been taken to keep the cores at conditions as close to the field as possible so that changes in chemical speciation of metals will be minimized. The filtering and preparation of core samples will be done in a nitrogen atmosphere. Once provision has been made for core analysis, future samples will be prepared and analyzed as they are taken from the field. A few representative cores will be preserved for the archives.

## RESULTS AND DISCUSSION

### Erie Wells

Water Levels---Groundwater contour maps were constructed for each water level measurement taken in the wells. Figure 12 is a representative example. The groundwater flow is to the north. The closer spacing of the groundwater contours in the south may be due in part to a damming effect created by the 8011 stockpile. This effect is seen throughout the year. The groundwater contour crossing W-26 and W-27 appears to change little over time. However, the up gradient wells, especially W-24, show greater fluctuations.

Generally, the highest water levels occurred in March and the lowest levels occurred in August-September (Table IV). Most wells show a gradual



decline in water levels during the summer with a gentle rise beginning in the fall.

Table IV. Water table elevations (ft. msl), Dunka Pit stockpile wells (24/1, 24/2, 27/1, 27/3 are piezometers).

Well Number	Depth (ft.)	Correction (ft. abv. gd.)	Ground Elevation (ft.)	March 14, 1976	March 17, 1976	July 1, 1976	August 19, 1976	September 30, 1976	October 7, 1976	October 18, 1976	December 13, 1976
W-22	4.5	3.8	1491	1491	1491		1490.8			1490.9	
W-23	9.0	4.6	1499	1496	1497		1495.3	1493.7	1493.7	1494.7	1494.5
W-24	10.3	3.0	1502	1499.5	1498	1496	1494.7		1496.6	1494.1	1494.5
24/1	4.0	1.0	1502			1498.6	1499.1	-			
24/2	1.8	1.2	1502				1500.3				
W-25	10.8	4.0	1491	1491	1491		1487.1	1484.6	1487.7	1487.6	1487.4
W-26	13.7	2.4	1488	1485	1486		1485.7	1485.2	1486.1	1485.6	1485.5
W-27	14.2	3.0	1486		1485	1485.7	1484.7		1484.5	1484.5	1484.5
27/1	12.5	2.5	1486			1485.2	1485.0	1485.2			
27/2	9.0	1.2	1486			1479.6	1484.9	1484.3			
27/3	3.8	1.2	1486			1483.0	1484.8	1483.7			

Piezometers at W-24 and W-27 indicate that the vertical component of groundwater flow is downward at W-24 and upward at W-27. This tends to support the theory that the stockpile is acting as a partial dam to groundwater flow.

#### Chemical Data

To date, complete analyses are available only for October 18, 1976.

Monthly sampling will afford better interpretation, once the data are in.

Field specific conductances suggest that the six wells can be divided into two groups designated as upgradient and down gradient from the 8011

Stockpile

Table VI. Well water chemistry, Erie Mining Company, Dunka Pit, October 18, 1976.

	Specific Conductance ( $\mu\text{mho/cm}^2$ @25°C)	pH	Alkalinity mg/l as CaCO <sub>3</sub>	Cl mg/l	DOC mg/l	Mn $\mu\text{g/l}$	Fe $\mu\text{g/l}$	Zn $\mu\text{g/l}$	Ni $\mu\text{g/l}$	Cu $\mu\text{g/l}$	Ca mg/l	Mg mg/l	Si mg/l	NO <sub>3</sub> -N mg/l	SO <sub>4</sub> mg/l	Co $\mu\text{g/l}$
<u>Up gradient wells</u>																
W-22	130	6.88	84.6	1.4							16.4	29.7	24	.04	37	
W-23	120	6.90	38.9	0.8	6.0	340.	4100	2.5	2.1	5.7	10.0	24.0	35	.01	15	2.5
W-24	460	6.90	74.1	1.8	19.	570.	14000	1.9	12.	6.2	52.0	96.0	40	<.01	290	4.5
<u>Down gradient wells</u>																
W-25	270	7.85	134.	3.5	16.	360.	1900	8.9	2.2	6.0	19.2	48.6	20	<.01	7.	0.9
W-26	285	7.75	142.	1.7	14.	900.	11000	1.3	0.5	1.9	25.2	42.6	24	<.01	<1.	1.3
W-27	210	7.82	110.	3.3	11.		5440	9.5	1.2	0.9	18.8	30.0	22	<.01	2.	1.0
Outwash Springs, 230 South Pit		8.20	85.5	7.7	9.3	160.	710.	16.	1.7	1.6	19.2	36.6		<.01	16	<.05

It is possible that water from the 011 discharge pipe may be affecting water levels in this well. The 011 discharge operates intermittently. Hence, slugs of water may be periodically entering the outwash and affecting the water level at the well.

The 011 discharge has its source in the south pit. Water chemistry for the seep in the south pit does not resemble W-24. Unfortunately, water chemistry for the 011 discharge has not been measured. It appears that the chemistry at W-24 may be controlled by the waste rock stockpile. Although the 8011 stockpile is classified as waste rock, sulfide-bearing gabbro has been found on the pile immediately adjacent W-24. If groundwater mounding exists within the pile, a southerly component of flow should exist off this mound that is counter to the regional groundwater flow. This may be the source of the sulfate-rich water and high levels of nickel that have been measured at W-24.

Table VII. Peat stratigraphy, location 3-4.

<u>Depth (m)</u>	<u>Description</u>
0-1.3	woody peat, well-decomposed
1.3-1.4	sphagnum
1.4-1.5	reedy peat
1.5	silty clay, gray, some sand

A portable conductivity meter (Myron L, EP model) was used to determine the zone of influence of Seep 3. Surface water wells and piezometers (1m depth) were installed across the bog (Figure 6). Locations 3-7, 3-8 and B-1 and B-8 are situated outside the zone of high conductance.

An early fall freeze-up has hampered the sampling of bog wells. Temperatures and specific conductance on October 7 indicate that most of the contamination and flow occurs at the surface (Figure 13). Unnamed Creek provides an effective eastern barrier to the influence of the seep.

It appears that cold Seep 3 water may have reached the first two piezometers. However, only the first piezometer shows any increase in conductance. This suggests that changes in chemistry do occur as the water flows through the peat. The nature of these changes must await further monitoring and full chemical analysis.

An experiment conducted at the Duluth Environmental Research Lab in November, 1976 compared levels of Cu, Ni, Fe, and Mn from six separate stations using water filtered through 0.45  $\mu\text{m}$ , 0.10  $\mu\text{m}$  membrane filters, and unfiltered water centrifuged at 50,000 rpm (230,000 X G) for one hour (Table VIII). The data suggest that part of the copper and much of the iron exists in the form of finely-particulate matter. Nickel, on the other

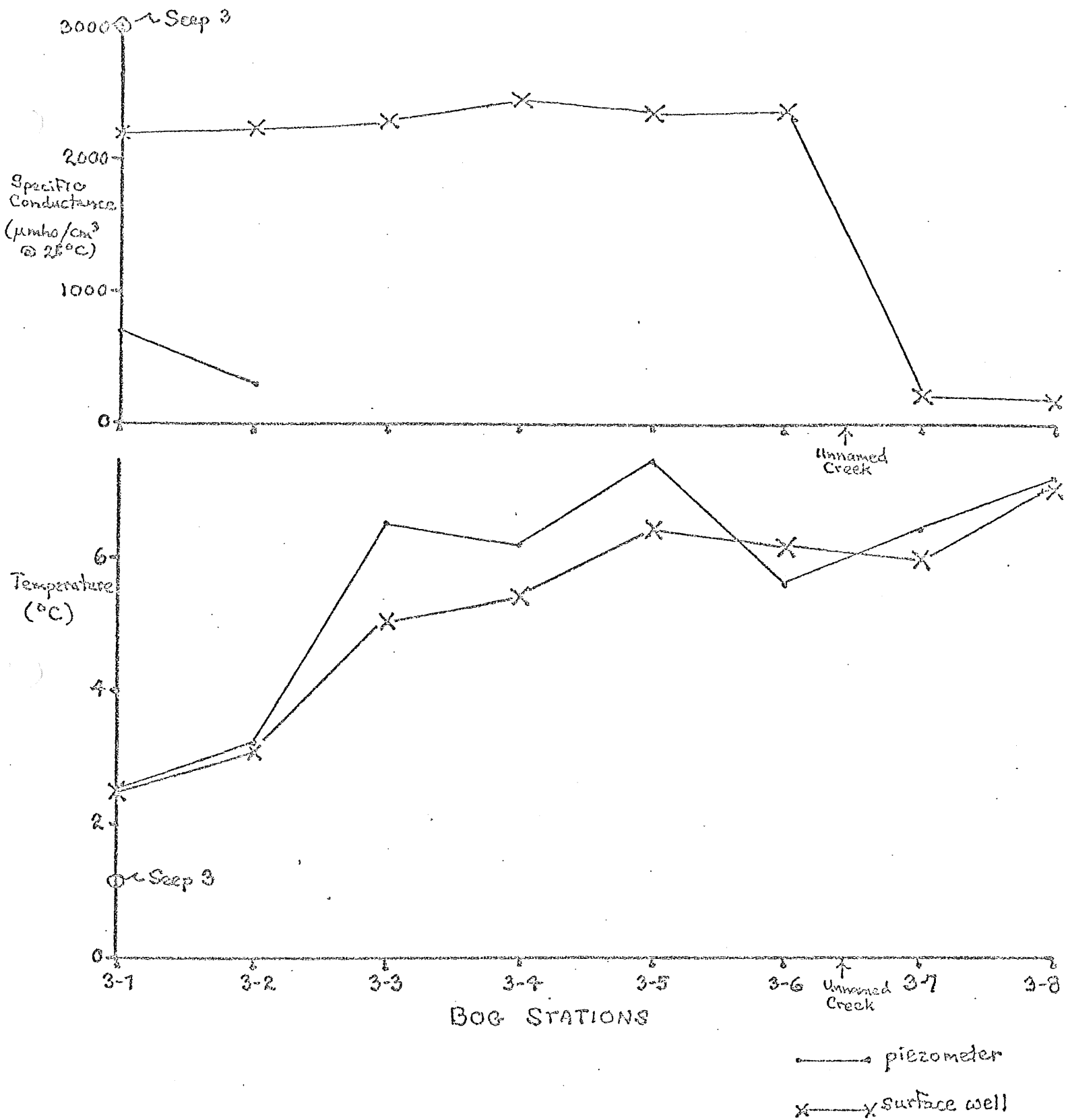

Figure 13. Specific Conductance and Temperature, Erie Bog, 7 October 1976.

UNNAMED CREEK

Hydrology

Unnamed Creek flow is dominated by mine dewatering discharges (Figure 5). The 011 discharge is the major source of water with an average flow of 4.1 cfs; the average flow of 012 discharge is 1.0 cfs. These discharges represent the large majority of Unnamed Creek flow. Water level recorders were installed by the USGS in late summer, 1976, at the following sites: EM-1, EM-3 and EM-8 (Figure 5). Rating curves were established for these sites, and mean daily flow rates (cfs) were calculated from the hydrographs. The results are tabulated in Appendix III, along with Erie Mining Company's estimated flows for the 011 and 012 mine water discharge pipes. Staff gages were installed at all other sites. Periodic discharge measurements were made and rating curves established. Rating curves for station 2 and 5 are presently classified as poor, especially at the higher end ( $\pm$  10 percent).

From data collected in July thru September, the 011 and 012 comprise 165 percent of the flow at EM-1. This discrepancy is believed to be due mainly to inaccuracies in the measurement of discharge at the pipe. The dewatering discharges are not continuous, rather, they fluctuate in a cyclical nature. This is particularly true of the 011 discharge. This fluctuating discharge produces oscillatory flow throughout the Creek. Typical hydrographs for station EM-3 and EM-1 are shown in Figure 14. The oscillatory nature of the flow is evident. At EM-1, the stage fluctuated 1.8 feet in a 24-hour period on October 14, 1976. The maximum rate of change during this period was 0.2 ft/hr.

Numerous beaver dams and constrictions also serve to complicate the inter-

pretation of flow data from Unnamed Creek. Note the date of September 12, 1976, from the following table (Table IX). On that date, the mean daily discharge at 011 was 7.4 cfs. However, downstream at EM-3 the flow was only 0.9 cfs while at the mouth (EM-1) it was 6.8 cfs.

Table IX. Mean daily flow, Unnamed Creek, September 11-15, 1976.

<u>Date</u>	<u>Discharge (cfs)</u>				
	<u>011</u>	<u>EM-8</u>	<u>EM-3</u>	<u>012</u>	<u>EM-1</u>
9/11/76	0.0	0.1	1.8	1.9	1.3
9/12/76	7.4	0.1	0.9	1.9	6.8
9/13/76	0.4	0.1	4.1	1.9	8.3
9/14/76	6.5	0.1	1.0	1.6	3.9
9/15/76	0.0	0.1	4.2	0.0	3.3

During the high flow, the marshes are completely flooded with water. This causes a delay in the crest of the flow and, like a capacitor, tends to shave off the tops of peak flows and fill in the valleys of low flows farther downstream. A comparison of flow data from EM-3 and EM-1 graphically shows this phenomenon (Figure 15).

Before an accurate model can be developed for the seep-bog-marsh-stream system, better flow information must be obtained. Beginning in the spring, the seeps will be gaged using Parshall flumes. Stream gaging will continue in order to refine the rating curves. An attempt will be made to obtain flow measurements at each time and point that a sample is taken.

A better method of measuring flow from the 011 and 012 discharges is needed before these data can be incorporated into our analyses. The feasibility of installing recording flow meters in the pipes is being investigated.

### Water Quality

Table X shows average concentrations for the 011 and 012 discharges. The data are restricted to only a few parameters. These discharges contain relatively low concentrations of copper and nickel. (Regional Water Quality data indicate, that, in general, background levels for copper and nickel in the study region are on the order of several  $\mu\text{g}/\text{l}.$ )

Table XI shows data for station EM-6. This station (Figure 5) is located approximately 3200 feet downstream of the 011. Two flow regimes are present. High flow corresponds to the dewatering discharge, while low flow represents water mainly from storage and some natural infiltration. (The change in stage between high and low flow is about one foot.) With the possible exception of total iron, there are no large concentration differences between high and low flow samples. High flow would transport more suspended material due to channel scouring. This additional material could account for the observed difference in total iron. In general, the water quality is typical of mine dewatering discharges for taconite operations (Oglebay-Norton EIS) and is characterized by a neutral to slightly basic pH, high alkalinity, high concentrations of dissolved solids, and generally low concentrations of heavy metals.

The type of flow fluctuations encountered in Unnamed Creek make the collection of a "representative" (average conditions) water quality sample difficult. The implicit assumption in most water quality programs is that the grab sample represents the true stream conditions for a specified time period (usually assumed to be the time between sample collections). For Unnamed Creek, these assumptions do not apply. Several possibilities for sampling schemes exist:

1. manipulate pumping to produce "stable" flow conditions (high or low);
2. sample at time of travel intervals; and
3. sample intensively over short periods of time.

Table XI. Water quality data, Unnamed Creek, Station EM-6.

Date	Low Flow			High Flow		
	<u>7/15/76</u>	<u>8/26/76</u>	<u>9/8/76</u>	<u>7/27/76</u>	<u>8/12/76</u>	<u>9/8/76</u>
Discharge (ft <sup>3</sup> /sec)	.32	.18	.68	6.09	7.10	6.18
pH	7.50	8.01	8.1	7.55	7.81	8.2
Alkalinity (mg/l as CaCO <sub>3</sub> )	86	88	99	95	92	104
Specific Conductance (µmhos/cm <sup>2</sup> )	521	329	346	500	347	390
Hardness (mg/l as CaCO <sub>3</sub> )	225	NA	NA	213	163	NA
Silica (mg/l)	11.4	NA	9.83	10.22	NA	11.0
Chloride (mg/l)	32.0	15.5	17.4	49.9	31.4	23.4
Sulfate (mg/l)	119	78	NA	123	74	32
Dissolved Organic Carbon (mg/l)	14.9	16.7	8.0	17.0	15.8	24.4
Dissolved Inorganic Carbon (mg/l)	12.0	7.2	23.5	15.5	12.9	7.2
Copper Total (mg/l)	.006	.007	.003	.016	.009	.006
Copper Filtered (mg/l)	.006	.005	.001	NT	.006	.006
Nickel Total (mg/l)	.024	.006	.004	.016	.009	.011
Nickel Filtered (mg/l)	.021	.008	.003	NT	.016	.011
Iron Total (mg/l)	.029	.122	.138	.594	.287	.207
Iron Filtered (mg/l)	.029	.058	.034	NT	.031	.034
Calcium (mg/l)	31.3	21.7	23.1	11.1	25.0	25.4



FIG. 16

HYDROGRAPHS AT TIME  
OF SAMPLING, JULY - AUGUST, 1976

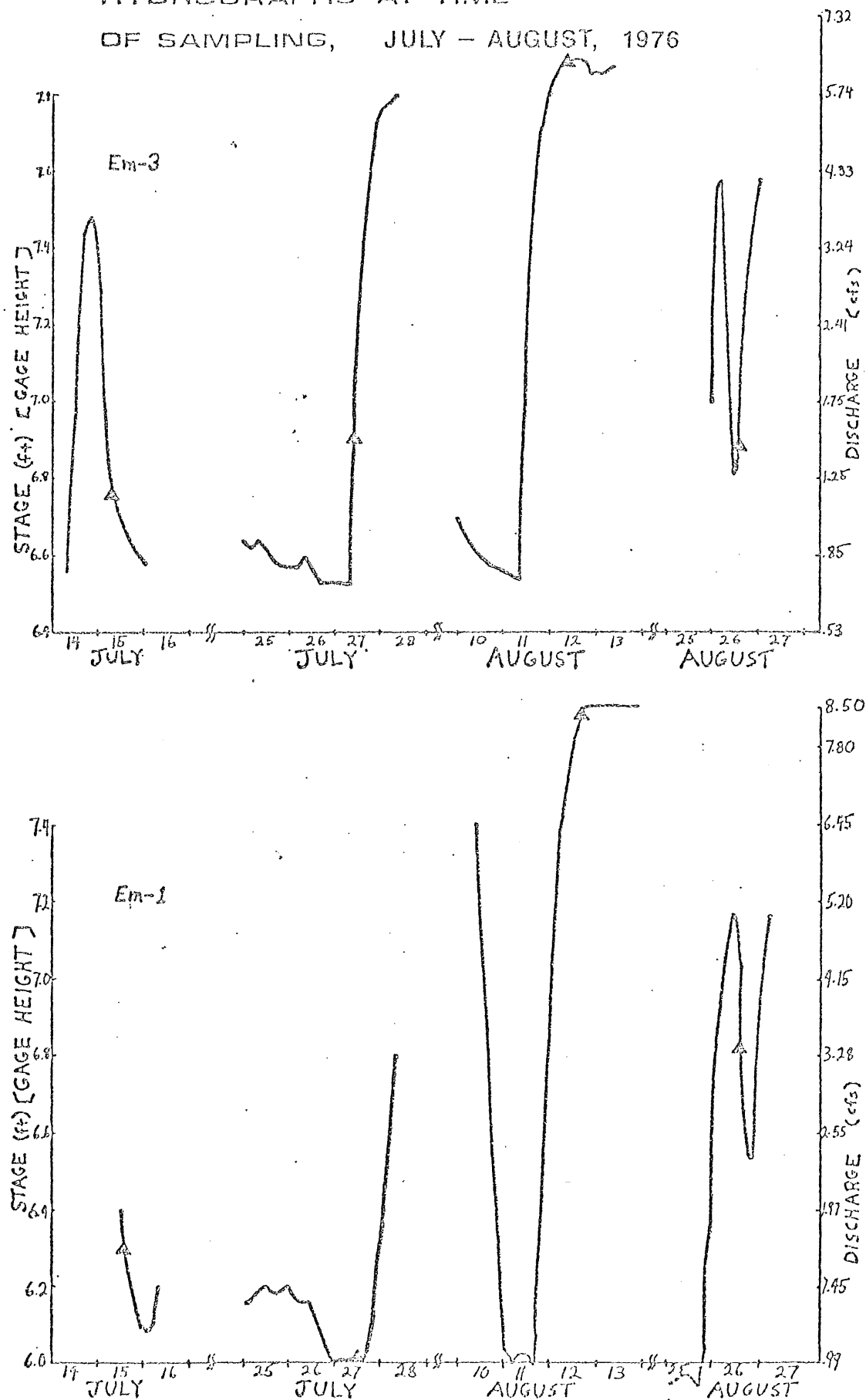

Table XII. Comparison of water quality; EM-6 & EM-1.

	Averages for period 7-1-76 to 9-21-76						8/12/76	
	EM-6			EM-1			EM-6	EM-1
	n	$\bar{X}$	S	n	$\bar{X}$	S		
pH	7	7.81	.30	7	7.63	.23	7.81	7.55
Alkalinity (mg/l as CaCO <sub>3</sub> )	7	93	7	7	101	14	92	97
Specific Conductance ( $\mu\text{mho}/\text{cm}^2$ )	7	387	91	7	680	166	347	604
Dissolved Oxygen mg/l	6	8.3	1.2	6	8.4	.4	8.1	7.9
Silica mg/l	5	10.46	.71	5	9.22	.48	---	---
Chloride mg/l	7	30.5	12.9	7	33.9	10.5	31.4	32.3
Sulfate mg/l	6	95	41	7	281	88	74	180
Dissolved Organic Carbon mg/l	7	14.8	5.9	7	19.2	6.9	15.8	27.4
Dissolved Inorganic Carbon mg/l	7	15.1	5.8	7	16.4	5.7	12.9	13.7
Copper								
Total mg/l	7	.008	.004	7	.004	.002	.009	.004
Filtered	6	.005	.002	7	.003	.002	.006	.003
Nickel								
Total mg/l	7	.010	.008	7	.123	.032	.009	.087
Filtered	6	.010	.008	7	.118	.033	.016	.082
Iron								
Total mg/l	7	.208	.190	7	.189	.046	.287	.171
Filtered	6	.043	.017	5	.141	.056	.031	.135
Calcium								
Total mg/l		23.2	6.1	7	48.4	10.1	25.0	41.2

n = number of samples     $\bar{X}$  = average value    S = standard deviation

Table XIII. Water quality comparison.

	Period of Record	Sample Number	Spec. Cond.	Alkalinity (mg/l as CaCO <sub>3</sub> )	mg/l Calcium	mg/l Copper Total	mg/l Nickel Total	pH
<u>Streams Receiving Mine Dewatering</u>								
Unnamed Creek (EM-1)	7/1 - 9/21/76	7	680	93	48.4	.004	.123	7.63
Unnamed Creek (EM-6)	7/1 - 9/21/76	7	387	101	23.2	.008	.010	7.81
Langley Creek (AMAX S-2)	7/76-8/76	3	445	91	(<5, 38) <sup>+</sup>	.001	.002	7.6
Dunka River (Regional D-1)	7/76-8/76	2	315	96*	35	data not yet available		7.4
<u>"Natural," Unimpacted Streams</u>								
Unnamed Creek (EM-4)	7/1 - 7/27/76	3	83	32	4.2	.002	<.001	6.7
Filson Creek (Regional F-1)	7/76	1	30	14	4	data not yet available		6.1
Dunka River (AMAX S-6)	7/76-8/76	2	77	30	10	.001	.002	6.6

\*August value.

+<5, July  
38, August

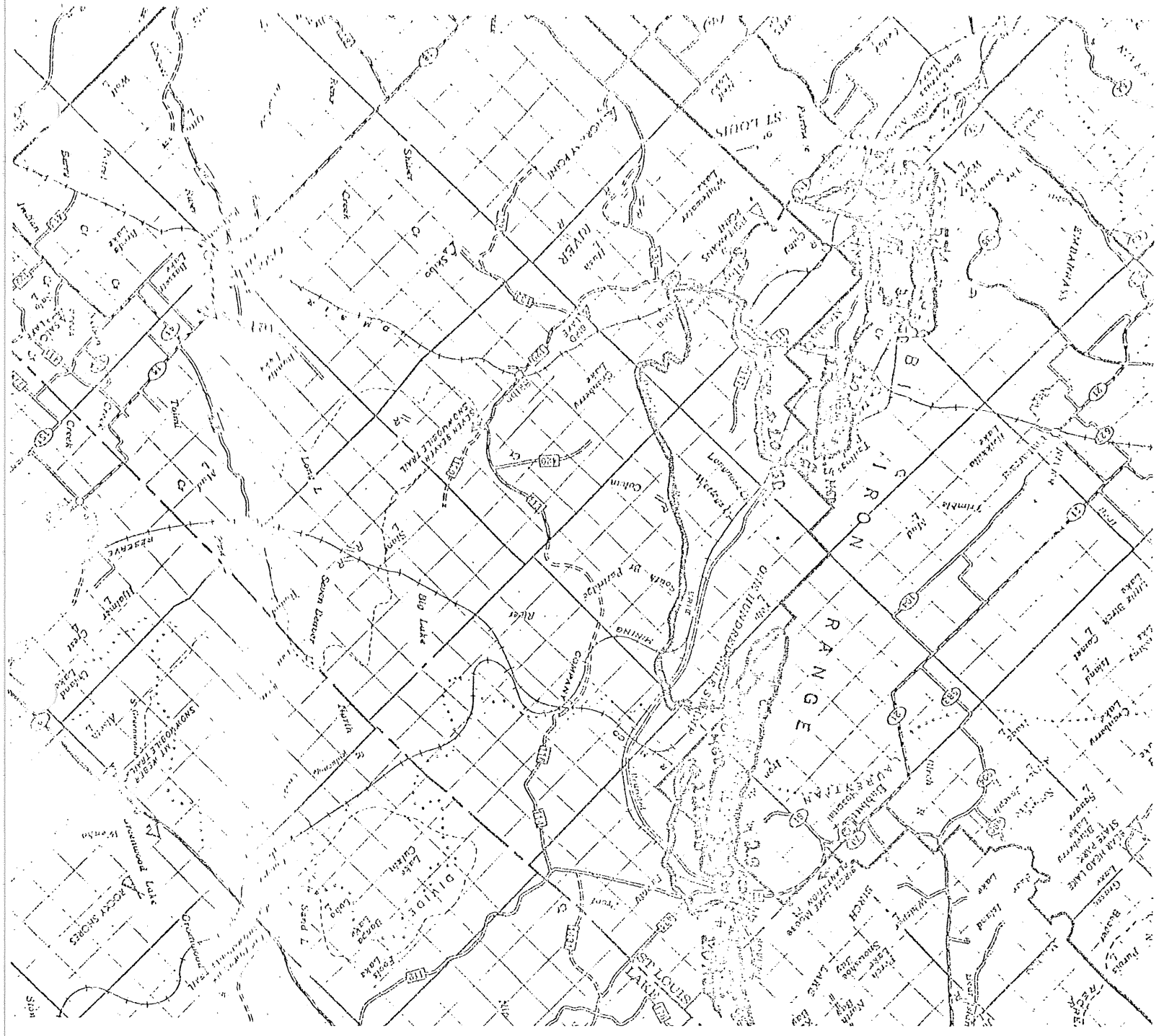

In general, the seeps are all characterized by high alkalinities (68-227 mg/l as  $\text{CaCO}_3$ ), neutral to basic pH, high sulfates (1000-2600 mg/l), high organic carbon (15-54 mg/l), and significant quantities of heavy metals, nickel (1-20 mg/l), copper (.02-1.8 mg/l), zinc (.03-.4 mg/l), cobalt (limited information: .130-.850 mg/l) and very low temperatures (.5-3.5°C). The water emanating from the piles is significantly lower in temperature than normal groundwater temperatures, which generally have a range of 10-12°C (Olcott, personal communication).

It is possible that ice lenses have formed in these stockpiles. These stockpiles are used during the fall and winter. The rock material would insulate ice and snow incorporated into the pile and prevent total melting during the summer. Some evidence of ice lenses in the 8014 were noticed during construction of drainage ways in 1975 (Erie Mining Company, personal communication).

Although the ratio of copper to nickel in the gabbro is 3-4:1, the ratio of these metals in the seepages is on the order of copper:nickel of 1:30 to 1:100. One of the classical problems associated with heavy metal sulfide mining has been the formation of acid mine drainage. This does not appear to be a problem for the gabbro material. Significant amounts of buffering capacity is being provided, probably through the weathering of the silicate minerals. Some of the material in these stockpiles is waste rock from the iron formation which may also contribute buffering capacity. The 8014 (origin of Seep 3) contains essentially all gabbro (Table II).

EM-9 - flow from the 8011 waste rock stockpile.

Chemical Data for EM-9 is shown in Table XIV. This is collected as far back into the pile as possible and is the best attainable representation of the condition of the water emerging from the stockpile. Figure 19 shows

Fig. 19.

# GENERALIZED CROSS-SECTION, 8011 STOCKPILE.

(vertical not to scale)

E

W

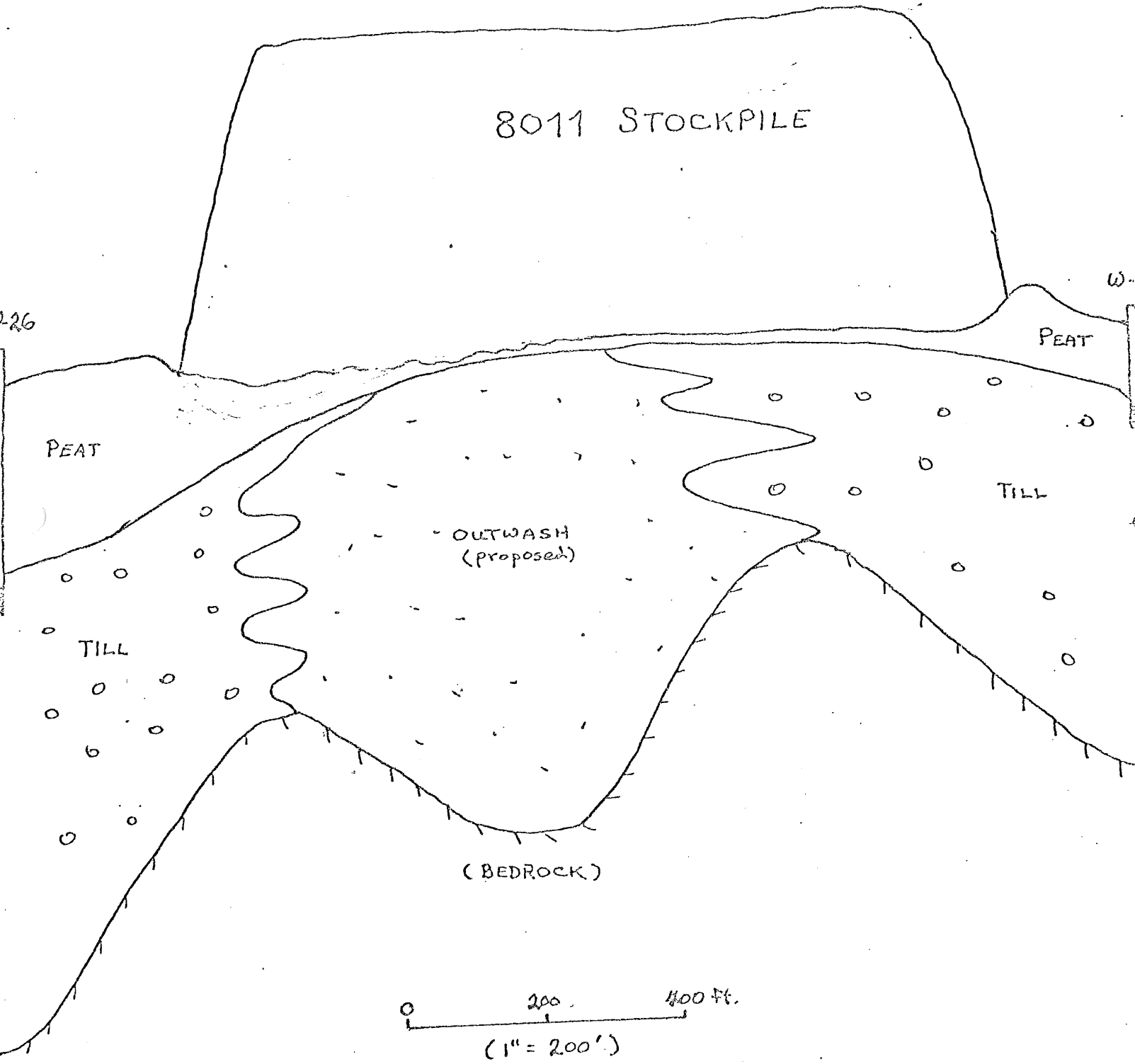
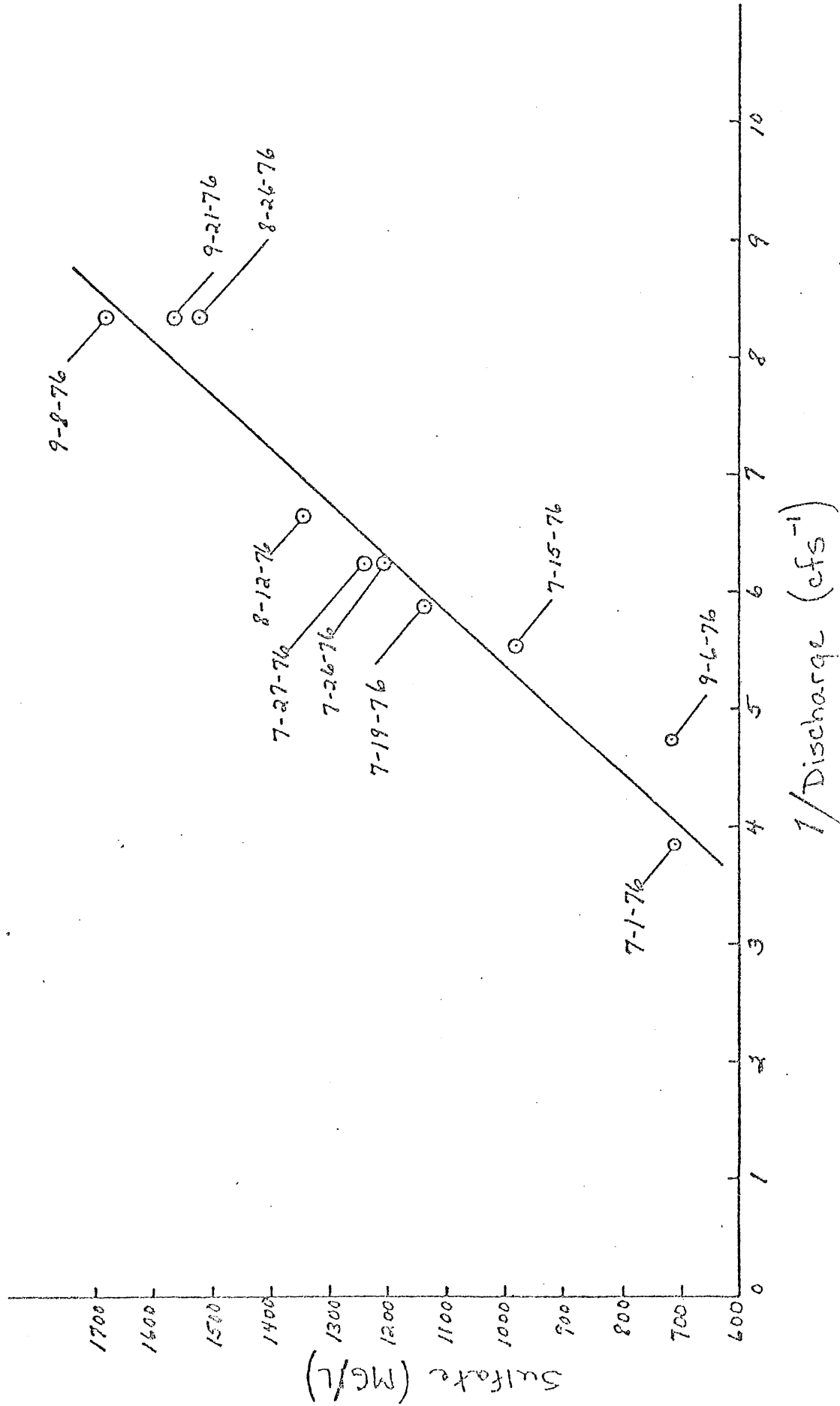

Table XIV. Comparison of EM-8 and EM-9.

Date	Sta.	D.O.	°C		Alk.	S.C.	Hardness (as CaCO <sub>3</sub> )	Hardness															
			Temp	pH				Si	Cl	SO <sub>4</sub>	DOC	DIC	Cu T	Cu F	Ni T	Ni F	Fe T	Fe F	Ca T	PO <sub>4</sub>	Zn T	Zn F	
7/1/76	EM-8			7.2	103	629	807	8.77	34.1	708	14.5	32.9	0.017	0.016	0.963	0.95	0.194	0.102	94.4				
	EM-9							STATION NOT SAMPLED															
7/6/76	EM-8	8.6 8.2	11.0	7.1	136		918	8.80	41.2	714	24.5	21.5	0.018	0.015	1.35	0.498	0.155	0.005	143				
	EM-9	<2.5	1.0	6.95	138		941		42.0	796	13.2	34.9	0.020	0.017	1.27	0.467	0.30	0.007	152				
7/15/76	EM-8	8.1	13.5	7.2	128 132	1695 1718	1134	9.99	39.1	980	26.0	15.7	0.020	0.018	1.60	1.56	0.166	0.058	64.9	0.019			
	EM-9	1.6	1.0	6.89	135	1811	1145	10.87	40.1	973	25.4	19.5	0.023	0.019	1.61	1.63	0.175	0.063	61.8	0.003			
7/19/76	EM-8	7.3	10.0	7.15	133	1850		9.61	40.7	1134	26.3	19.0	0.016	0.015	0.580	0.570	0.114	0.086	154				
	EM-9	1.2	0.5	7.1	138	1930			42.0	1144	26.2	19.8	0.022	0.020	1.67	1.60	0.131	0.074	163				
7/26/76	EM-8	6.6	10.0	7.09	130	1980	1195	9.34	43.9	1203	19.0	24.5	0.016	0.015	1.89	1.94	0.114	0.073	163				
	EM-9	1.3	0.5	6.83	131	1980	1238		41.4	1119	20.0	28.5	0.022	0.020	2.06	1.97	0.254	0.073	168				
7/27/76	EM-8	6.0 6.4	6.0	7.01	133	2080 1950	1348	9.89	45.3	1237	20.0	26.5	0.019	0.018	1.97	2.10	0.09	0.045	178				
	EM-9	1.4	0.5	7.0	130	2048	1348	10.26	42.0	1095	17.0	28.0	0.022	0.021	1.89	1.89	0.114	0.086	200				
8/12/76	EM-8	6.75	11.5	7.10	124	2250	1310		56.5	1346	21.4	17.4	0.021	0.020	2.40	2.40	0.134	0.045	214		0.035	0.031	
	EM-9			7.00	133	2305	1340		55.6	1381	28.2	13.4	0.026	0.023	2.38	2.36	0.150	0.056	228		0.029	0.034	
8/26/76	EM-8	7.3	8.8	7.4	130				29.2	1564	26.5	19.5	0.018	0.016	2.36	2.40	0.095	0.057	230		0.038	0.035	
	EM-9	1.0	0.9	7.32	136	2900			28.8	1619	24.9	19.8	0.018	0.016	2.36	2.32	0.126	0.063	241		0.035	0.032	
9/3/76	EM-8	NT	8.0	7.4	150	2600				1685	36.3	10.3	0.017	0.016	2.42	2.40	0.139	0.072	241		0.037	0.035	
	EM-9	NT	1.0	7.4	154	2060				1529	32.6	17.3	0.020	0.018	2.36	2.36	0.139	0.079	248		0.035	0.030	
9/21/76	EM-8	7.9	3.0	7.65	145	2740			13.0	38.0	1523	11.5	37.5	0.020	0.016	2.42	2.56	0.208	0.134	248		0.040	0.033
	EM-9	2.2	1.8	7.35	152	3018			9.65	38.0	1386	12.0	39.5	0.019	0.018	2.52	2.49	0.211	0.111	244		0.043	0.044

Units: Alk. mg/l as CaCO<sub>3</sub>  
 S.C. specific conductance umho/cm<sup>2</sup>  
 all other parameters in mg/l

Fig. 22 SULFATE vs. 1/DISCHARGE EM-8





that the data can be modelled by an expression of the form:

$$\text{Concentration} \times \text{Discharge} = \text{Constant}$$

$$\text{or} \quad \text{Loading} = \text{Constant}$$

For the period of time represented by this data, the rate of release of nickel and sulfate were constant. (Kinetically, this is known as a zero order process.) This type of release could be explained by a zero order chemical reaction or a diffusion reaction model, with diffusion as the controlling step. [The fact that the data fit a particular model does not prove the model's applicability, rather, it suggests a possible mechanism that can be compared with laboratory data.] The 8011 Stockpile was started in 1965; by the fall of 1972, the edge of the pile had reached the old drainage course (Figure 21). It is conceivable that the rock has had sufficient time to weather and develop an oxide coating.

### Plans

Additional groundwater samples will be collected to determine input conditions. Some of this water will be used in laboratory leaching tests for field-lab correlations. A groundwater tracer study through the pile will be attempted next year. This information, coupled with quality and flow information, will provide more data on actual field leaching rates.

### Seep 3

Seep 3 originates from gabbro pile 8014 (Figure 24). During 1975, in an effort to reduce leaching problems, Erie began to drain the area around the stockpile. At this time, a steel drain pipe was placed as shown. This was then covered with pad material. The actual sampling point occurs at the discharge point of the pipe which is about 1000 feet from the pile.

The chemical characteristics for this seep are shown in Table III. High concentrations of nickel, copper, zinc and cobalt (limited data) are evident. For copper, there is a significant difference in total versus filtered values. The filtered value (4 determinations) ranges from 68-95 percent of the total metal concentrations in the sample. This may be a result of copper precipitation or an artifact resulting from sampling the very low flows of the seep (bottom disturbance). This difference will be looked at in greater detail next year. The concentration of nickel remains relatively constant throughout the summer. Copper concentrations were higher in July, but stabilized in August and September. Sulfate concentrations fluctuated in the early samples, but leveled out toward the end of August.

Figure 25 is a cross section through the 8014, showing the original surface and the present stockpile. Bedrock slopes upward to the west in this area and there is no seepage into the pit. Surface and groundwater are moving toward Unnamed Creek. In the cross section, a large flat and possibly depressed area can be observed. Water may be trapped in this area. Figure 26 is a cross section through the 8011 and the 8014. There is a significant elevation drop between the two stockpiles and it is unlikely that the two seeps are connected. Recharge is possible for the 8014 from surface water runoff and the stockpile itself (Figure 24). The location where the water leaves the stockpile is also consistent with the trapped water model. The high levels of copper and nickel concentrations are also consistent with this model, being indicative of a more stagnant situation in contact with higher mineralization. If water is trapped and draining such that the level of water is decreasing, the flow would decrease in a linear fashion. Figure 27 is a plot of discharge versus time for seep 3. The relationship is approximately linear. (Heavy rainfall would complicate the interpretation since recharge would occur.)

FIG. 26.

# GABBRO STOCKPILE 8014

# WASTE ROCK STOCKPILE 8011

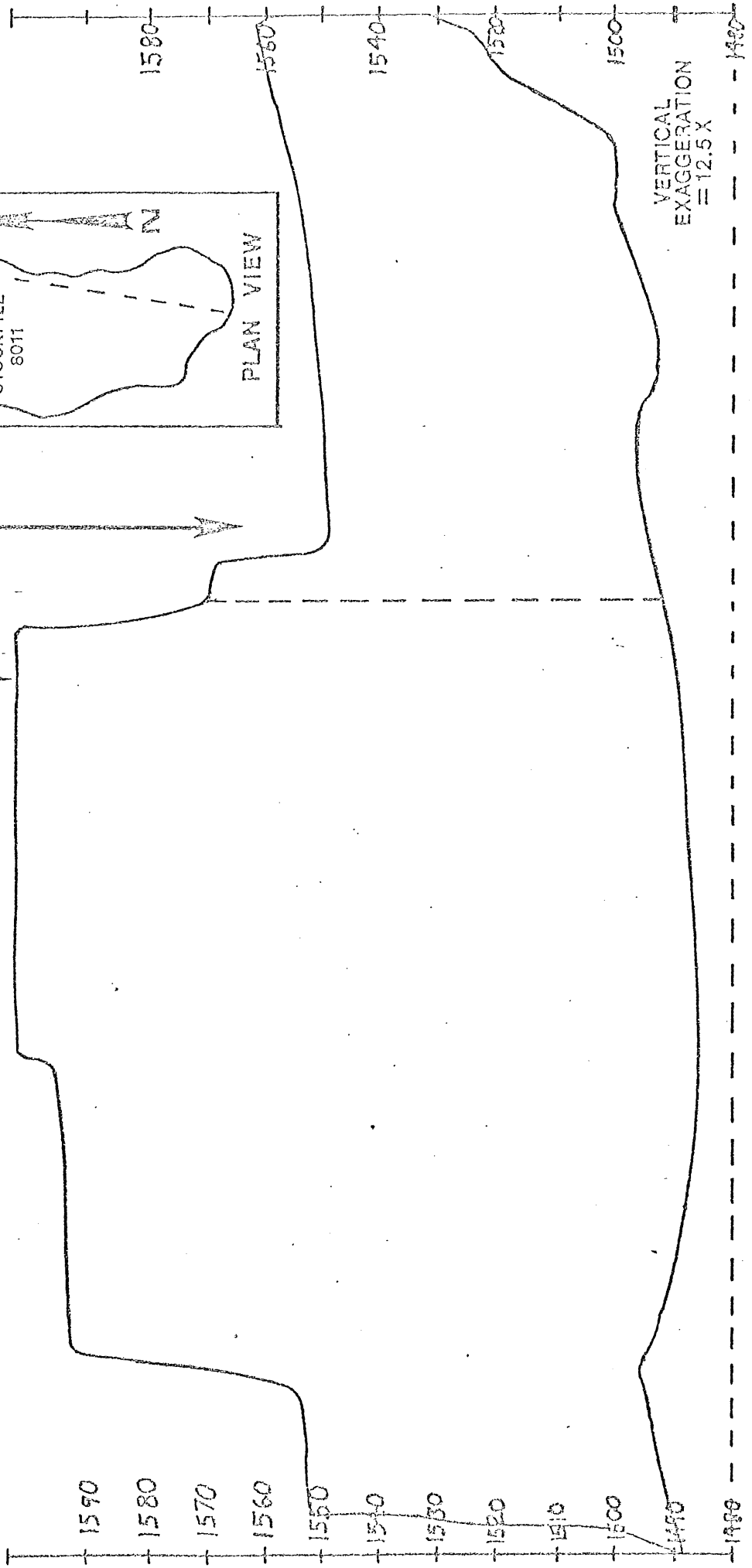
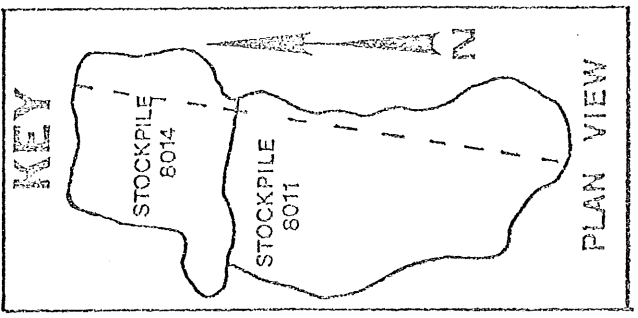

VERTICAL EXAGGERATION = 12.5 X

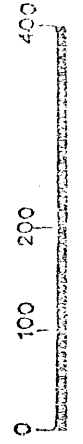

SCALE IN FEET

An approximate calculation (Appendix III) indicated that sufficient water to account for flow of this seep could be provided by seven inches of water in the stockpile.

The conclusions drawn are preliminary, but they are indicative of possible mechanisms. More detailed work will be conducted next spring and summer at Seep 3. A parshall flume will be installed to provide better flow data and sampling will be more intensive.

#### Seep 2

Seep 2 is related to Seep 3 (Figure 24). During periods of high runoff, seepage from the 8014 emerges via Seep 2 and 3. The Seep 2 samples that were collected this year were from stagnant pools. This seep will be examined in more detail in the spring.

#### Seep 1

Seep 1 originates from waste rock stockpile 8013 (Figure 29). The data are tabulated in Table III. Nickel concentrations generally decrease throughout the summer, while copper is essentially constant at levels comparable to EM-9. Iron concentrations, both total and filtered (limited data), and dissolved organic carbon are significantly greater than Seep 3 and EM-9 (Table III). Water from this seep has a tendency to foam when placed in a bottle and shaken. This is similar to the foam produced when water containing swamp drainage flows over a rapids. The high iron, organic carbon and foam behavior are all consistent with bog drainage. Figure 28 shows a cross section through the 8013 Stockpile. There is approximately a 14-foot elevation difference between the bog and the seep.

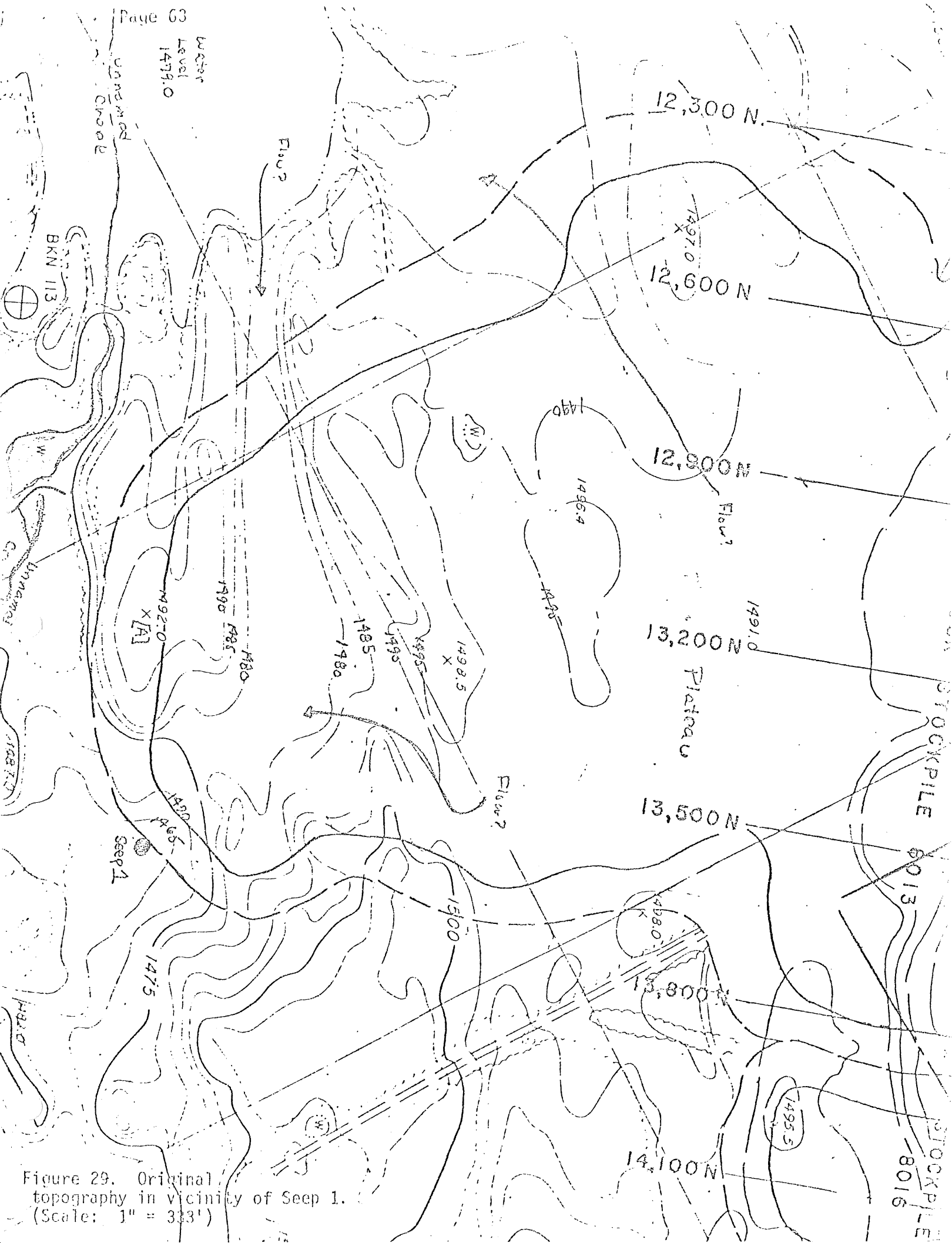
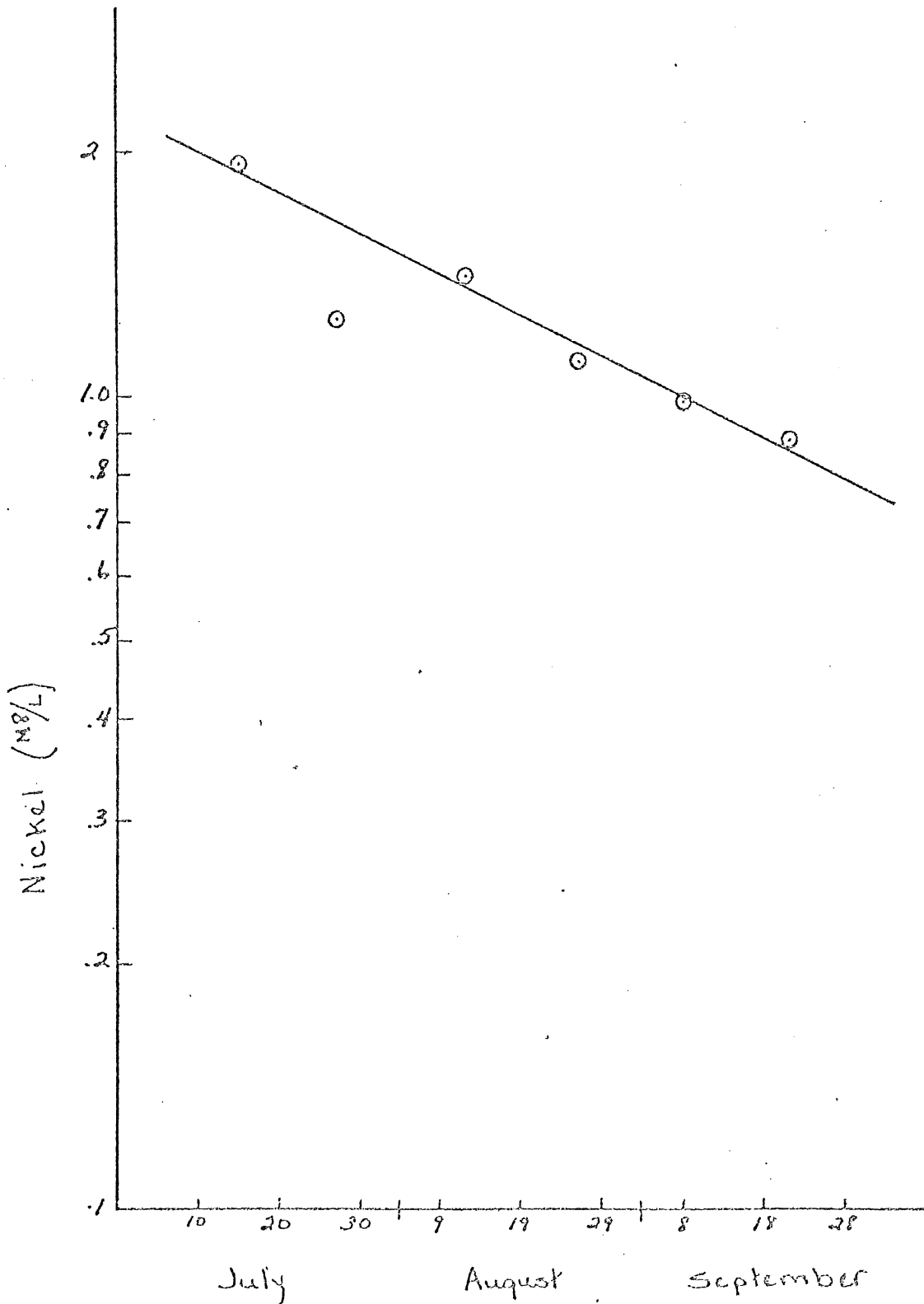
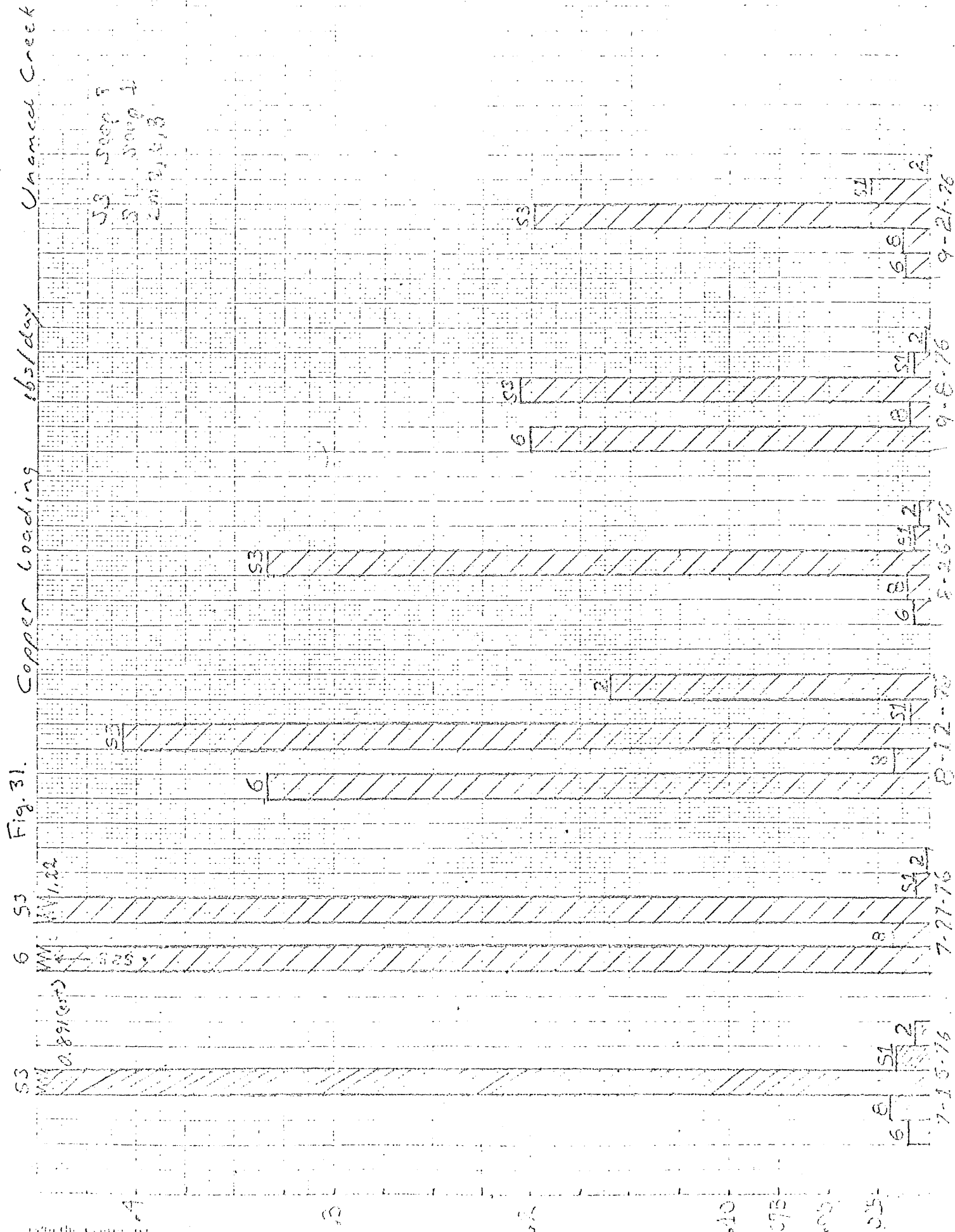

Figure 29. Original topography in vicinity of Seep 1. (Scale: 1" = 333')

Fig. 30. NICKEL vs. TIME EM SEEP 1





Unamed Creek

Fig. 33. Zinc Loading 16/day

S3 seep  
S1  
8

(no zinc data for 8/23/76)

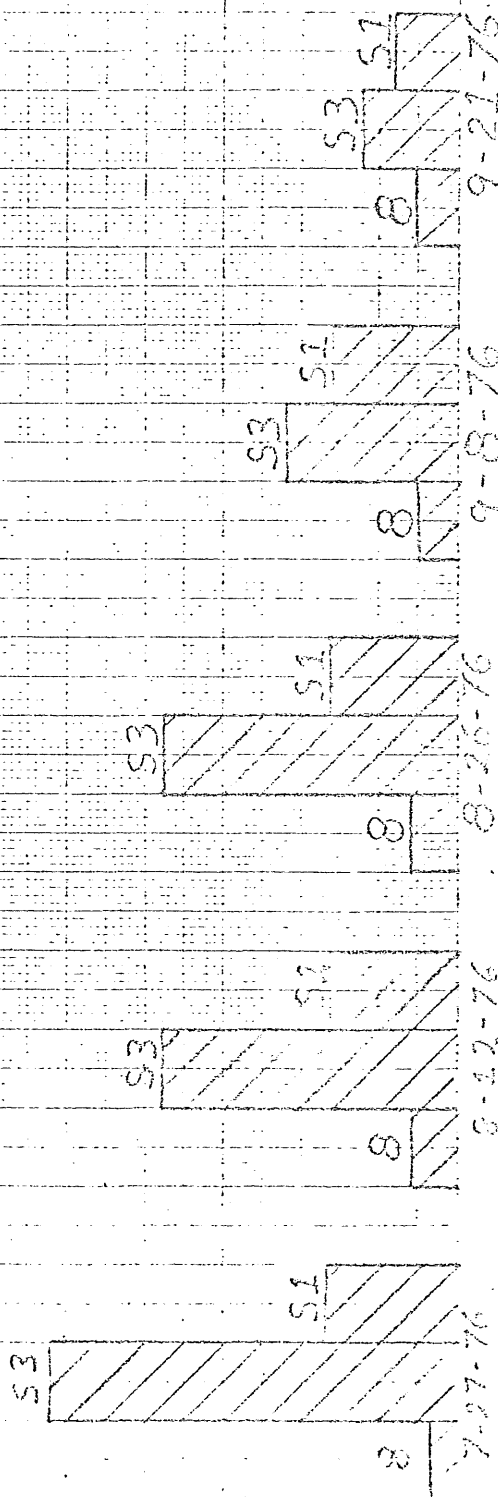



The "system" could represent any portion of the ecosystem, eg. a stream segment. The first approach is to assume a steady state situation, i.e., the accumulation within the system is zero. If the chemical constituent being considered is conservative (it does not undergo any reactions), then the mass balance becomes

$$\text{input} = \text{output}$$

For the Unnamed Creek situation, the dynamics of the system are complex. In addition to the fluctuating flow, field observations have identified other complicating factors. As mentioned previously, during high flow, the marsh near Seep 3 is partially flooded. This flooding action sweeps high conductivity and presumably elevated heavy metal water down stream.

The discharge from EM-8 and Seep 1 flows directly to the stream. Seep 3 flows into a white cedar-alder bog. The water level was at the surface throughout the summer, suggesting a saturated condition. If the bog was saturated, then any water flowing into the bog ("system") would be balanced by an equal amount of outflow. Some of this outflow could occur as discharge to the stream, but much of it is probably lost through evapotranspiration. If this is the case, the flow measured at Seep 3 would not represent the input to the stream.

The first approach is to assume that the loadings over a two-week period are constant. If the contribution of station 6 can be taken to be zero, the mass at any station, for a conservative substance, will be constant.

Dewatering discharge is treated as a variable volume of dilutant. The load is then determined on an instantaneous basis:  $\text{load} = \text{concentration} \times \text{discharge at time of sampling}$ . For parameters in which the load from station 6 cannot be neglected, the simple mass balance approach will only work for stable flow conditions or samples collected on a time of travel basis.

Fig. 3a Nickel bar of Unnamed Creek 7-15-77

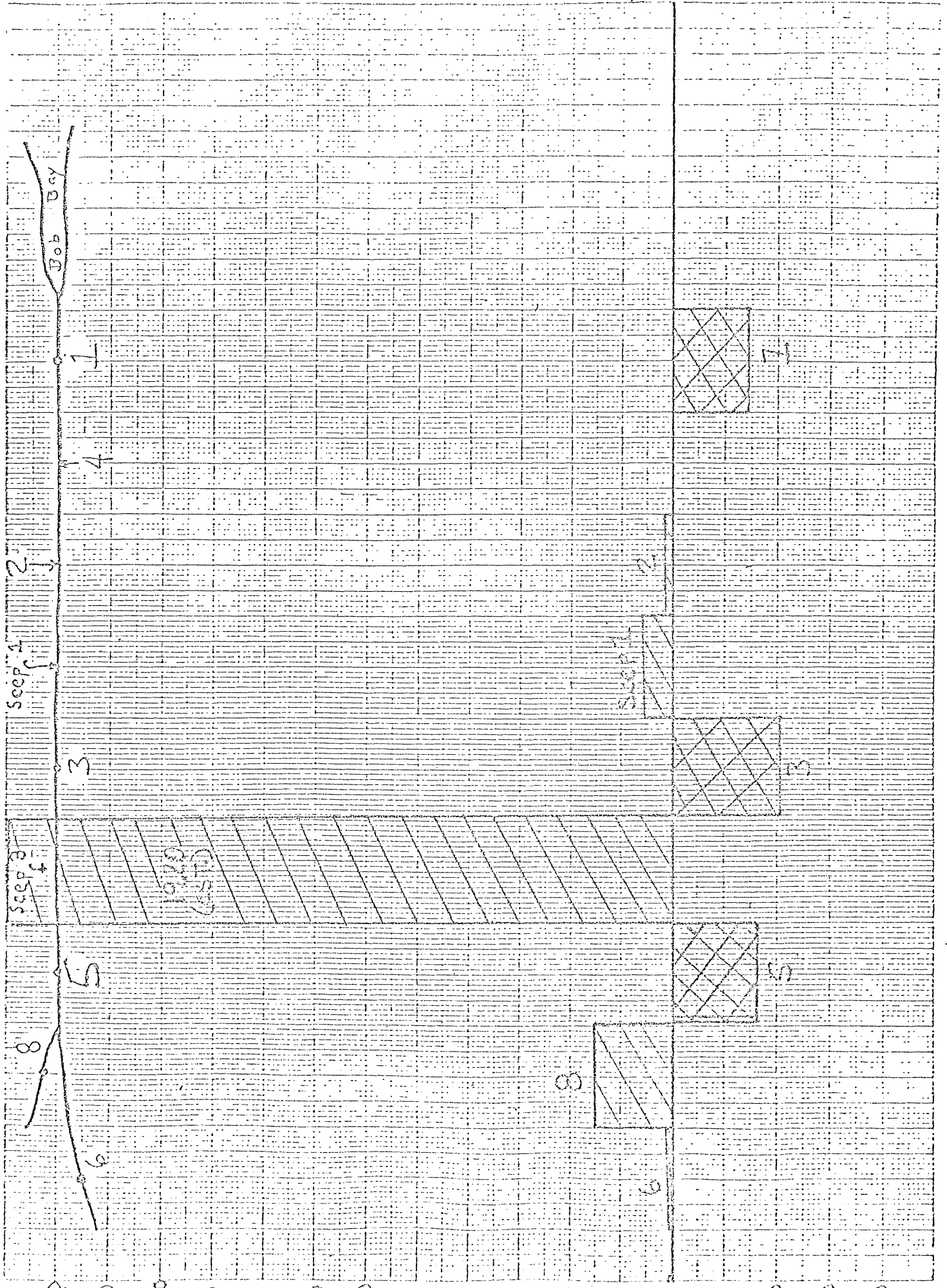

Fig. 37 Nickel Loading - Unnerd Creek - 8-12-76

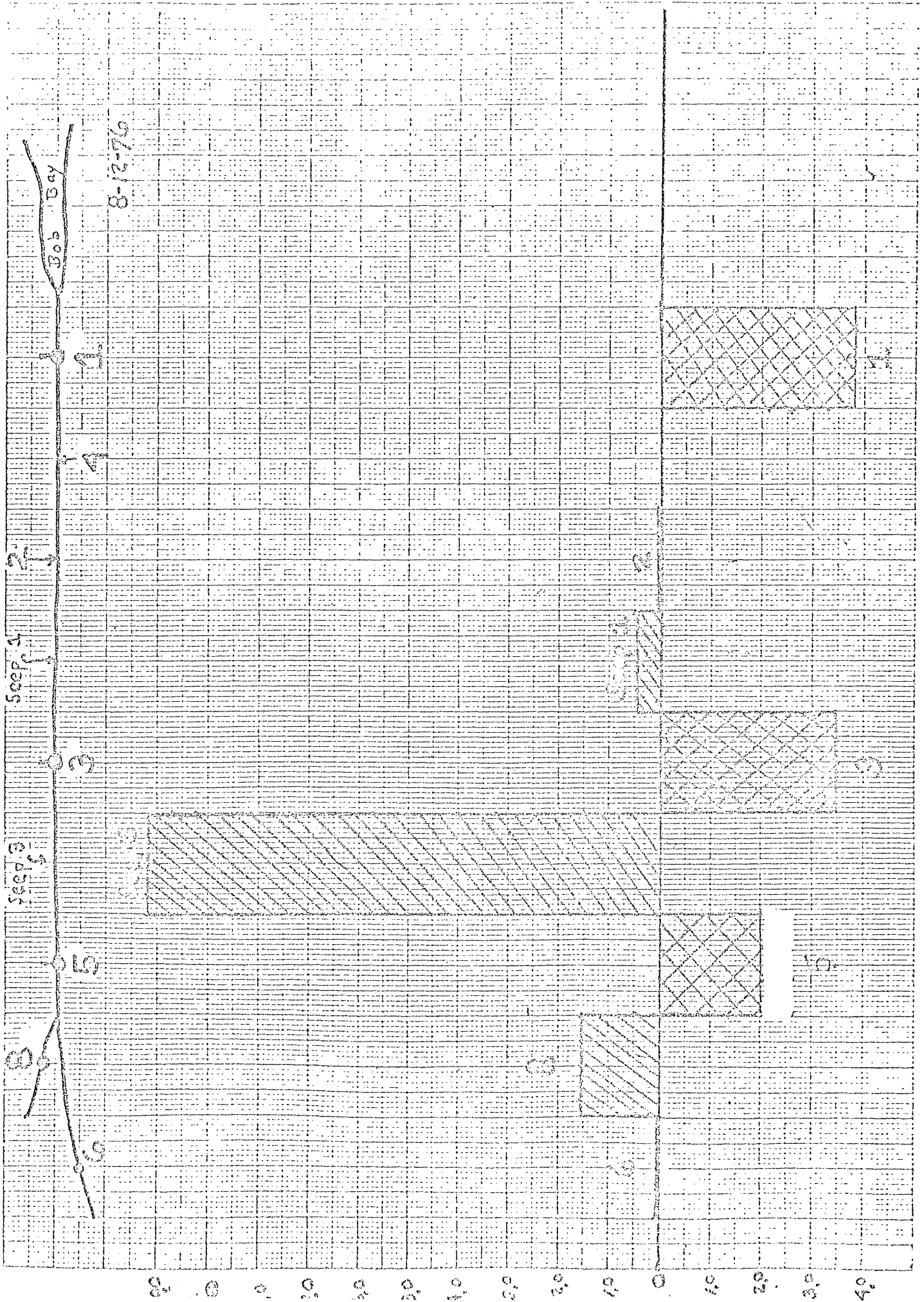
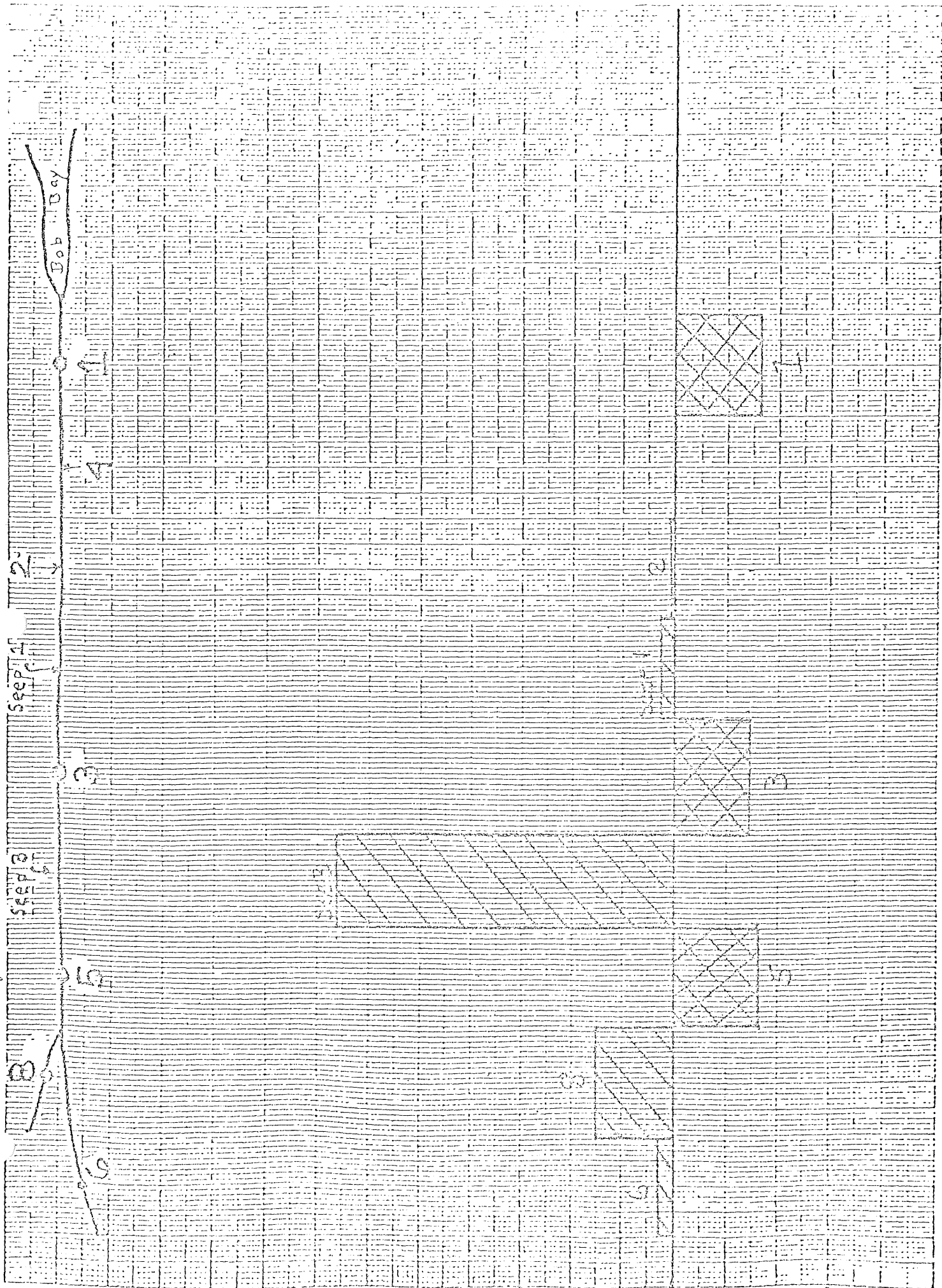
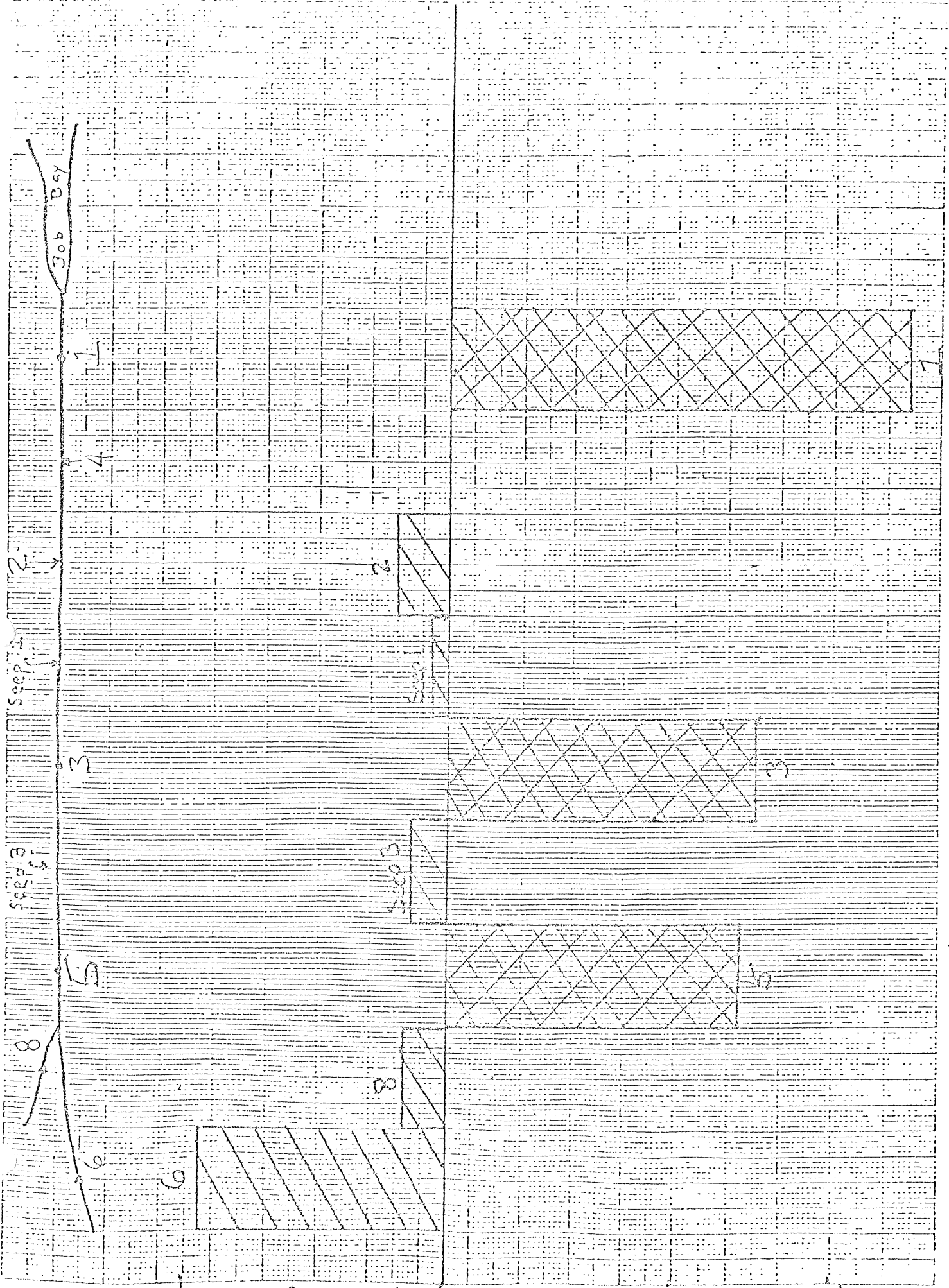

Fig. 27



7/27/2008  
CALCIUM WASTE 100/50/100  
SOP/100/100



10 8 6 4 2 0 2 4 6 8 10 12 14 9 8

Fig. 43. Siltstone loads - Unnamed Creek 8-12-70

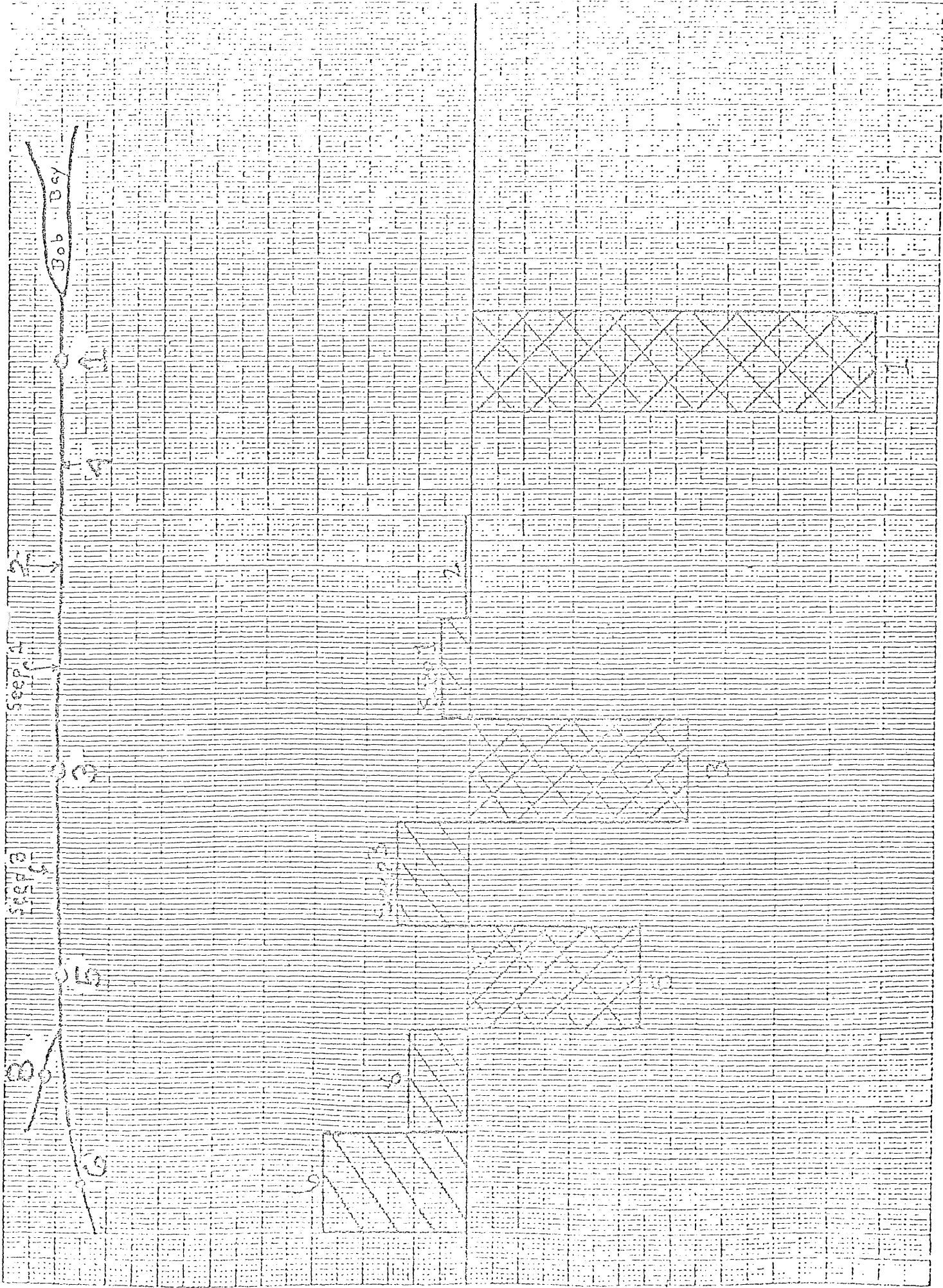

Table XV. Stream loading of nickel as determined by segment (lbs/day).

Transport Segment 1: EM-8 + EM-6 = EM-5

Date	Load EM-8	Load EM-6	Sum of EM-6 & EM-8	EM-5	EM-5 measured/ EM-5 calculated
7-1	1.34	ND	1.34	1.60	1.19
7-15	1.55	.04	1.59	2.12	1.33 *
7-27	1.70	.52	2.12	1.21	.57*
8-12	1.94	.34	2.28	2.06	.90
8-26	1.52	.006	1.53	1.28	.84
9-8	1.56	.37	1.93	1.73	.90
9-21	1.76	.01	1.77	1.49	.84

(ND = Nickel concentration not detectable)

Transport Segment 2: EM-5 + Seep 3 = EM-3

Date	Load EM-5	Load Seep 3	Sum of EM-5 & Seep 3	EM-3	EM-3 measured/ EM-3 calculated	EM-3 measured/ EM-5 measured
7-15	2.12	19.2	21.3	2.17	.102*	1.02
7-27	1.21	12.91	14.1	3.37	.24 *	2.79*
8-12	2.06	10.22	12.28	3.48	.28 *	1.69*
8-26	1.28	10.49	11.8	1.50	.13 *	1.17
9-8	1.73	6.65	8.4	1.43	.17 *	.83
9-21	1.49	5.25	6.75	2.56	.38 *	1.72*

Transport Segment 3: EM-3 + Seep 1 + EM-4 + EM-2 = EM-1

Date	Load EM-3	EM Seep 1	Load EM-4	Load EM-2	Calculated	EM-1 Measured	Measured/ Calculated
7-15	2.17	.62	0	.11	2.90	1.46	.50 *
7-27	3.37	.40	0	.02	3.79	.93	.25 *
8-12	3.48	.45	0	.13	4.06	3.78	.93
8-26	1.50	.36	0	.06	1.92	1.66	.87 *
9-8	1.43	.32	0	.03	1.78	1.74	.98
9-21	2.56	.29	0	.02	2.87	.53	.18 *

\*Error ranges for loads do not overlap, difference appears to be significant.

Table XVI. Stream loading, calcium, chloride, sulfate, 8/12/76.

Transport Segment 1		EM-6 + EM-8 = EM-5			
	Load EM-8	Load EM-6	Sum of EM-6 & EM-8	EM-5	<u>EM-5 measured</u> Sum 6 & 8
Calcium	172.7	955.0	1127.7	1158.5	1.03
Chloride	45.6	1199.4	1245	1259.4	1.01
Sulfate	1086.2	2826.6	3912	3366.1	.86

## Transport Segment 2

	EM-5	EM Seep 3	Sum of EM-5 & Seep 3	EM-3	<u>EM-3</u> Seep 3
Calcium	1158.5	139.9	1299.5	1213.7	.93
Chloride	1259.4	37.9	1297.3	1189.1	.92
Sulfate	3366.1	1400.4	4766.5	4279.5	.90

## Transport Segment 3

	EM-3	Seep 1	EM-1	EM-3 & Seep 1 EM-2	EM-1	<u>EM-1</u> Sum
Calcium	1213.7	75.2	201.8	1490.7	1791.0	1.20
Chloride	1189.1	27.2	156.3	1372.6	1404.1	1.02
Sulfate	4279.5	593.6	645.6	518.7	7824.7	1.42



METAL FORMS

The classical approach to metal measurements has been to consider total metals vs. an operationally defined dissolved metals (defined as those which pass through a .45 $\mu$  filter). This cutoff does not really separate metals which may be in particulate or colloidal form from those that are truly in solution. In an effort to better define the mode of occurrence of metals in the Unnamed Creek watershed, two pilot projects were undertaken. Table XVII is a summary of the complexing capacity and the results of differential pulse polarography on samples from Unnamed Creek. Several attempts were made to analyze samples from the seeps, but due to the high concentrations, analytical difficulties were encountered. These results are preliminary, but they do indicate: 1) significant copper complexing capacity exists; and 2) nickel can be measured by techniques which determine "free" nickel. (It is important to point out that these measurements are made at pH 6, and must be interpreted carefully. Changes in pH will effect metal speciation and complexation.) More work will be done to better define the metal speciation. Table XVIII is a summary of metal concentrations of different fractions of six samples collected from the Seep 3 area and Unnamed Creek. As was discussed previously, the data suggest that part of the copper and much of the iron exists either free in solution or as low molecular weight complex.

Table XVII. Copper complexing capacity and differential pulse polarographic analysis of Unnamed Creek samples.

Date	Station	Copper Complexing Capacity ( $\mu\text{g}/\text{l}$ )	Differential Pulse Polarography	
			Nickel ( $\mu\text{g}/\text{l}$ )	Cadmium ( $\mu\text{g}/\text{l}$ )
9/21/76	EM-1	108	294	< 24
	EM-1	95	NA	NA
11/8/76	EM-6	51	NA	NA
	EM-5	83	646	< 24

Samples analyzed by Tom Bydalek, UMD

filtered values). The percent does not agree exactly with the model prediction. More work will be done to examine this difference.

#### BOB BAY-DUNKA BAY

Unnamed Creek discharges into Bob Bay (Figure 3). A program to study the transport and effect of the elevated levels of heavy metals was established. Since no premining information is available for Bob Bay, it was necessary to choose control areas for comparison. The main body of Birch Lake is being sampled by the regional water quality program at four sites. Dunka Bay was chosen as an additional control area. The Dunka River receives mine dewatering discharge but does not have elevated heavy metal concentrations. The major concern was to choose an area that was impacted by mine dewatering, but did not have elevated metal concentrations. Dunka Bay is the best control for the purpose. The data from Birch Lake (background) will also be used for comparison

Both bays have an appropriate north-south orientation. At Bob Bay, the bedrock is of the Duluth Gabbro Complex whereas at Dunka Bay it consists of members of the Iron Formation. Shore line vegetation along both bays consists of second growth mixed conifer-hardwoods. Both bays are uniformly shallow with depths that vary between 1.0-1.5m. Dunka River enters Dunka Bay from the south. Each bay opens into Birch Lake along a steep slope that drops to approximately six meters in depth. Bob Bay is 4600 feet along and has a width that varies between 275 and 625 feet. Dunka Bay is 3000 feet along and has a width that varies between 650 and 1020 feet.

Sampling sites are shown in Figures 7 and 8.

show the highest elevations. Iron, on the other hand, may be somewhat higher in Dunka Bay.

The data suggest that Dunka Bay and Bob Bay may both have a bottom layer of water that is higher in conductance and alkalinity. The significance and duration of this phenomenon must await further analysis.

Future sampling will be aimed at better defining the transport of the discharge through the bay and documenting the levels of exposure to which the biological communities are subjected. A detailed chemical analysis of bay and lake sediments will begin this winter. Of particular interest is the content of metals in the organic layer of sediment. Sediment cores will be prepared for analysis quickly after they are taken. In order to analyze both the interstitial water and solids phase of the sediment methods, of core squeezing in a nitrogen atmosphere are being investigated. Detailed methods and analysis procedures will be worked out in the coming weeks.

#### Bioassay

Samples of various leachates (Erie and US Steel) have been tested by Bob Drummond, ERLD, using "cough response" techniques. Preliminary results have not been fully evaluated but some of the samples have produced measurable effects. The purpose of the initial set of samples was to scan various leachates and to indicate the magnitude of potential problems.

Table XX

SAMPLE SITE: Dunka Bay; Bob BayDATE: 8-31-76

	BB3	BB3	BB4	BB4	BB6	BB6		DB2	DB2	DB2	DB3	DB3	10						
Depth(m)	0.5	1.5	0.5	1.5	0.5	1.5		0.5	1.5	1.0	0.5	1.5							
pH	7.9	7.8		7.8	7.75	7.6		7.2	7.0	7.35	7.4	7.25							
ALK	42	45		34		22		26	40		26	26							
Spec. Cond.	209	220	179	190	99	90		121	145		114	91							
DRSi	2.58	3.46	2.58	6.43	1.82	--		--	5.06	--	1.36	1.49	ND						
Cl	10.0	10.7	8.3	10.2	6.2	--		8.3	12.6	--	7.4	7.2	ND						
SO <sub>4</sub>	105	108	92.7	96.1	92.1	125		6.4	16.7	--	6.3	7.2	ND						
DOC	17.0	15.8	16.8	17.6	15.2	16.7		13.6	10.5	--	15.4	18.8	0.5						
DIC	11.0	10.5	10.9	10.4	17.6	7.2		8.4	10.8	--	7.8	7.7	0.3						
Cu T F	.003	.002	.002	.002	.001	.004		.001	.001	.001	.001	.001	ND						
Ni T F	.022	.022	.021	.019	ND	0.46		ND	ND	ND	ND	ND	ND						
Fe T F	.313	.316	.285	.285	.253	.421		.443	.614	.997	.399	--	ND						
Zn T F	<.01	<.01	<.01	<.01	<.01	<.01		<.01	<.01	<.01	<.01	<.01	<.01						
Co T F																			
Pb T F																			
Mn T F																			
Ca T	12.2	12.6	11.0	11.5	6.9	23.1		6.6	9.4	6.4	6.0	7.2	1.5						
Mg T																			
Al T F																			
Cu T																			

Table XXI. Water quality data, US Steel.

	5/24/76			7/29/76			9/1/76			9/7/76		9/30/76	
	1	1	2	3	1	2	3	1	1	3			
pH	6.4	5.90	5.89		6.5	6.45		6.0					
Alkalinity (mg/l as CaCO <sub>3</sub> )	5	~1	~1		~1	~1		~1					
Specific Conductance (umhos/cm)	15	349	346		420	420		437					
Dissolved Oxygen		8.0	8.25		9.6			8.7					
Temperature (°C)		24			15.5			19					
Silica		13.9	13.9	ND									
Chloride	.59 <sup>+</sup>	1.23	1.32	ND									
Sulfate	100 <sup>+</sup>	240	241	ND	266	271	ND						
Dissolved Organic Carbon		ND	1.8	1.0				5.3	2.0	1.0			
Dissolved Inorganic Carbon		ND	ND	ND				8.0	.5	.5			
Copper, Total	1.29*	2.42	2.36	.001	3.07	3.07	ND	3.24					
Copper, Filtered		2.45	2.36	.001	3.05	3.05	ND	3.24	1.00	ND			
Nickel, Total	6.10*	6.70	6.60	ND	8.00	8.00	ND	8.38	9.45	ND			
Nickel, Filtered		6.70	6.60	ND	7.90	8.00	ND	8.58	10.0	ND			
Iron, Total		.038	.003	.008	.065	.058	ND	.134	.142	ND			
Iron, Filtered		.011	.004	.001	.014	.016	ND	.061	.065	ND			
Calcium, Total		17.0	16.9	.3	7.5	7.6	ND		26.0	ND			
Zinc, Total		ND	ND	ND	ND	ND	ND	.124	.140	ND			
Zinc, Filtered		ND	ND	ND	ND	ND	ND		.142	ND			
Cobalt, Total													
Discharge (ft <sup>3</sup> /sec)													
Other		Cd* 1.12ug/l Ag* .02 ug/l											
Hardness		173	180	ND									

+ = Analysis by USGS, Salt Lake City

\* = Analysis by ERLD

Blanks mean no analysis for that parameter performed.

Samples 1 and 2 are duplicates

Sample 3 is a blank

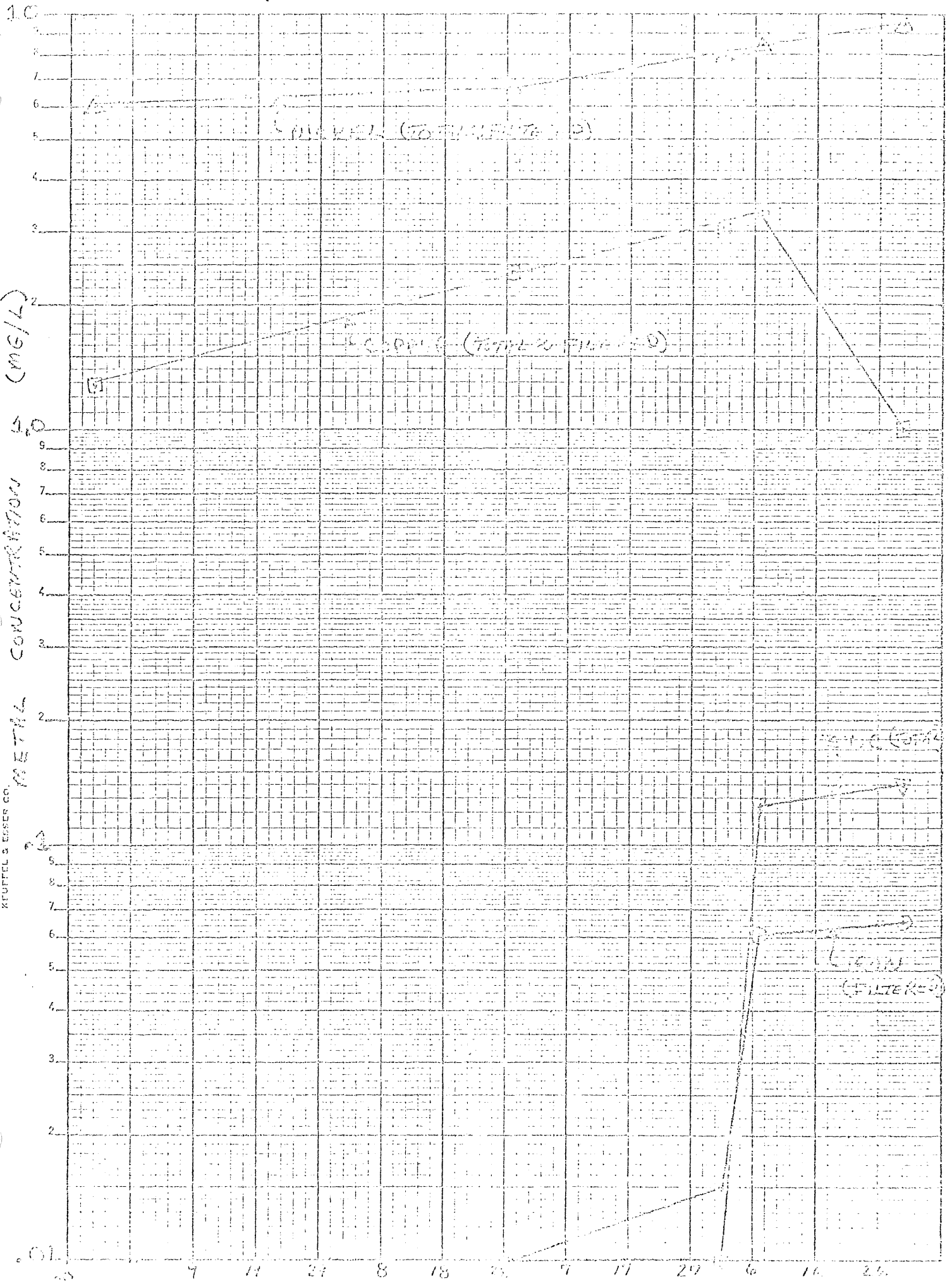

SEMI-LOGARITHMIC 40 5492  
 5 CYCLES X 10 DIVISIONS  
 KEUFFEL & ESSER CO.

METHANE CONCENTRATION (MG/L)

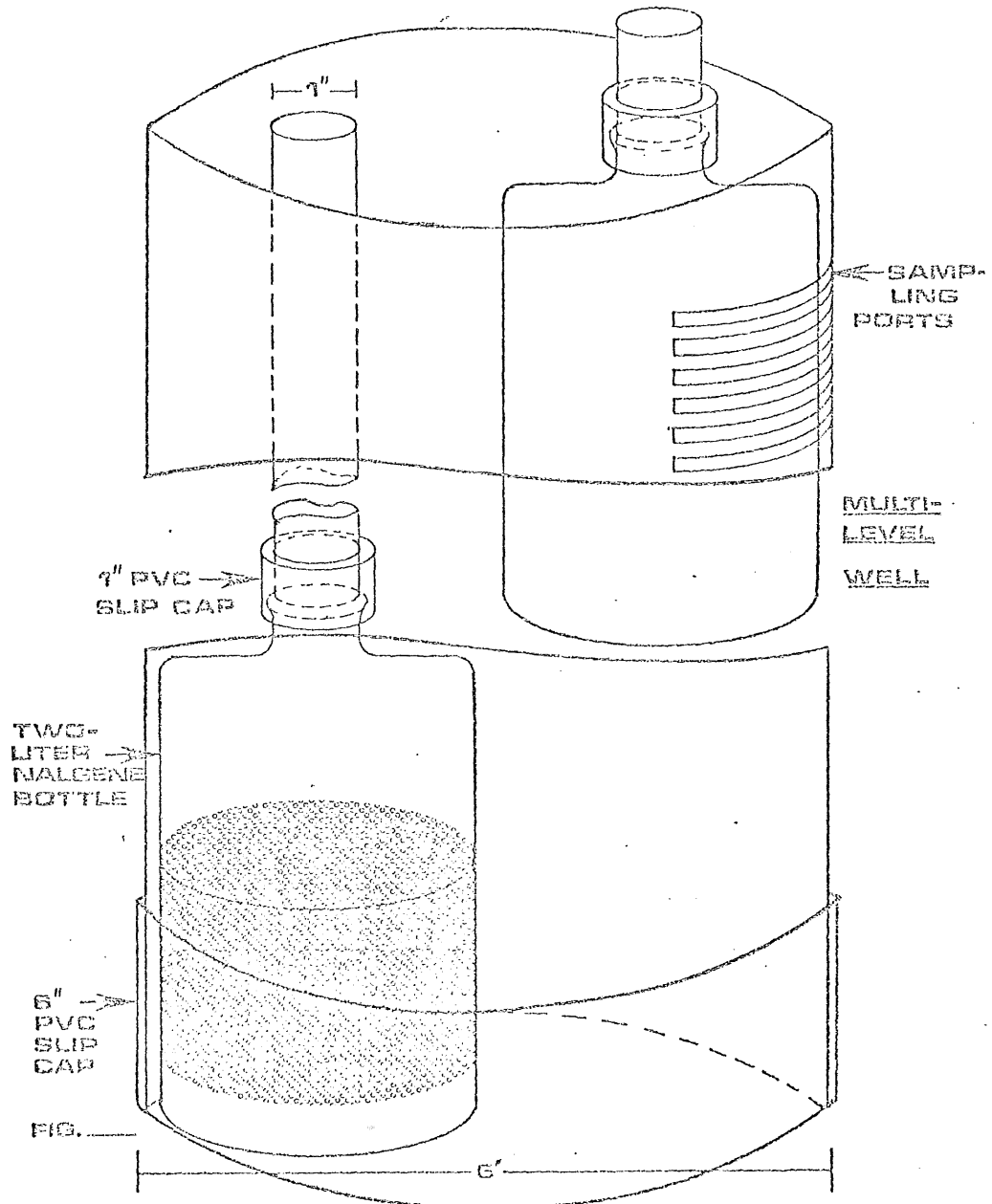

Figure 45. Multilevel well.

FUTURE PLANS - SUMMARY

To date, most activity has centered upon the Dunka Pit where active leaching is presently taking place. It remains to be seen whether sufficient time will exist for comparable levels of leaching to be observed at Minnamax before our study ends.

At Dunka Pit, plans are to install a water level recorder on W-24 to document changes in water level. Better methods are also needed for recording the flow of the O11 discharge.

Erie Mining Company will survey in the bog wells, assigning elevations to each. This will enable the construction of groundwater gradients similar to what is being done around the 8011 stockpile.

Erie Mining Company has indicated a desire to investigate the extent of the outwash aquifer by drilling a series of test holes. Wells placed in these holes will extend the groundwater flow net over a larger area and perhaps answer the questions of what role Dunka River and the O11 discharge play in recharging the aquifer. Stream gaging on the Dunka River may also shed light on this question. Summer field work will also include a detailed examination of the glacial stratigraphy in the vicinity of the Dunka Mine.

More cores will be taken along the line of wells outward from Seep-3. It is especially important here to obtain core samples over the entire peat thickness.

A laboratory is being sought to handle core analyses. Methods for core preparation and analysis will be worked out prior to the beginning of the spring field season.



APPENDIX I  
PROCEDURES

3. Unless otherwise noted, the samples were taken by the methods in this manual.
4. Any data marked "U" means unreliable.
5. In the Field notes, there are areas with blanks, ie. results for hardness. In this case, a line will be drawn through the sector, to indicate no comment, not applicable, etc.
6. All Barnstead correction factors are written directly below the conductance on the Field note sheet.
7. The EM-10 FM blanks were not filtered until 7/27/76. The procedure prior to this date was to pour deionized distilled water directly into the 60ml bottle, without filtration.

### Alkalinity Procedures

#### Preparation of Reagents:

1. Acid wash all glasswear.
2. Boil distilled deionized water for 15 minutes and let cool to room temperature.
3. After cooled, add 8.3 ml Conc HCl to 1 liter of this water; this will make a 0.1 N HCl solution.
4. To prepare .02 N HCl: add 200 mls of .1 N HCl to 1 liter of boiled deionized water. This must be standardized with .02 N  $\text{Na}_2\text{CO}_3$  prepared in the following fashion: dissolve 1.060g anhydrous  $\text{Na}_2\text{CO}_3$  oven dried into 1 liter of  $\text{CO}_2$  free distilled water.
5. Take a 100 ml sample of the  $\text{Na}_2\text{CO}_3$  solution and titrate with acid to pH 5.1-4.5-4.2; do this 3 times and average ( $\bar{X}$ ) out the mls of titrant to each respective pH.

#### 6. Calculation:

$$\text{Normality, N} = \frac{A \times B}{53.00 \times C}$$

Where; A = normality  $\text{Na}_2\text{CO}_3$

B = ml  $\text{Na}_2\text{CO}_3$   
sol. taken for titration

C = ml of acid used

7. The titrant should be standardized at a minimum of once every 7 days.

### Sampling Procedures

1. The sample will be taken in a 1 liter bottle that has been washed by the Minn. Dept. of Health. Rinse 3 times with the sample water.

a calibration curve with temperature as the variable. The probe should be re-platinized monthly.

Both instruments should be kept warm (above 0°C) before use. This may require putting them in insulated containers.

Methods for Chemical Analysis of Water and Wastes. 1976: viii, Table 2.

Standard Methods for the Examination of Water and Wastewater. 1971, 13th Ed: 323. Method 154.

### pH Procedure

1. pH measurements should be made insitu, if at all possible. If not, pH must be measured within 6 hours of collection, unless data, as to the shift for that specific site, show there is no significant shift problems (0.1 pH unit) in holding beyond 6 hours. The time and date of reading (if different from the sampling date) must be written in the field notes.
2. Use a 1 liter general parameter bottle; rinse the bottle 3 times with sample water. Take the sample mid-stream below the surface of the water. Fill the bottle as full as possible. Try to let as little air in the bottle as possible.
3. Store bottle at 4°C, but prevent from freezing.
4. Calibrate the pH meter with buffers of pH 4.0, 7.0 and 10.0.
5. Invert the sample bottle rapidly 20 times and rinse the beaker with the sample. Pour the sample in the beaker. Stir the sample slowly by hand or with a magnetic stirrer. Measure pH; make sure to let the meter equilibrate for at least 1 minute before taking reading.
6. Rinse beaker and electrode with deionized water.

### Insitu Readings

7. Calibrate pH meter as in step 4. Place probe in the stream at mid-stream; let equilibrate at least for 1 minute; read pH.

Standard Methods for the Examination of Water and Wastewater. 13th Ed. 276-279. Methods 144, 144A.

Methods for Chemical Analysis of Water and Wastes. 1976, Table 2: viii.

2. To wash used bottles; rinse with 50 percent  $\text{HNO}_3$ , soak bottles in 10 percent  $\text{HNO}_3$  for at least 1 day and rinse 3 times with 10 percent  $\text{HNO}_3$ .
3. After step 1 or 2, whichever is applicable; rinse the bottle 3 times with distilled deionized water. Place in ziplock or whirl-pac plastic bags until use.

#### Filter Unit Preparation

1. Rinse swinnex or aseptic unit with 10 percent  $\text{HNO}_3$  3 times; use at least 50 mls each rinse for all rinses.
2. Rinse units with deionized water 3 times.
3. Put a .45 $\mu$  Millipore Membrane Filter on the filter holder, rinse filter and unit with 0.2 percent  $\text{HNO}_3$  three times.
4. Rinse unit with distilled deionized water 3 times.
5. Put filter unit into a ziplock or whirl-pac plastic bag and keep in as clean an area as possible.

#### Use in Field - Field Filtration - Stream

1. At site\*; carefully place a prewashed 60 ml bottle into the bottom of the aseptic or swinnex unit. Filter approximately 40 mls of water through the unit.
2. Take off the unit and carefully put cap back on bottle; remove from unit and shake at least 20 seconds. Discard this water and repeat step 1. Taking a 60 ml sample.
3. Remove the bottle as described in step 3 and acidify the sample with 0.1 ml  $\text{HNO}_3$  to 60 mls of sample.
4. Cap sample and place in a sealed plastic bag until shipped.

\*Take all samples upstream from all nearby metal objects (ie. staff gages weirs, etc.) as close to mid-depth mid-stream as possible.

USEPA Method, by Dr. John Poldoski, 1976.

#### Total Metal Field Procedure

1. Place station date and the letters TM on a strip of masking tape. Then put the masking tape on the bottle; seal the bottle in a whirl-pac or ziplock plastic bag. Keep the bottles in as dustfree an area as possible.

8. Titrate as soon as possible.
9. Titrate with Hach PAO .0375 N until the solution turns a light straw color, add a few drops of starch solution, titrate to clear. mls of titrate = D.O. in mg/l.

Standard Methods for the Treatment of Water and Wastewater. 13th Ed.  
1971: 477.

YSI Model 54  
Calibration

1. The D.O. meter must be calibrated weekly prior to sampling. The membrane should remain wet in storage and during transport.

On Site

2. If in a moving stream, suspend the probe at mid-stream in such a way as to let water pass freely across the membrane.
3. Adjust zero and red line on the instrument and then put switch on D.O.; let the meter settle for at least 1 minute; read the D.O. directly.
4. In a lake, after putting the probe at a specific level, raise and lower it 10-12 cm slowly and smoothly. Take the reading as in step 3. The movement passes water across the membrane to increase the accuracy of the reading.

Calibration of Meter

Fill a 1 liter beaker with water, carefully pour off 300 mls into a BOD bottle and follow steps 4-9 on pages 46-47. After the DO is obtained, carefully place the probe and the remainder of the water into the beaker. Stir gently, calibrate the meter to read the winkler value. Repeat this procedure at least once more to double check calibration. The calibration should not vary more than 0.3 ppm from the first winkler.

APPENDIX II  
QUALITY CONTROL

program, the maximum shift acceptable is 0.1 pH unit or a 1.3 percent variation from the insitu reading. In order to evaluate the maximum holding time, data were collected at the EM-1 site. EM-1 was chosen because it is an "average" site in the Unnamed Creek drainage and represents the outflow of the watershed. To delineate the time involved for the shift, pH readings were taken on five separate samples with time intervals from 0 to 26 hours (Table 1). The results show that the time of  $>.1$  shift is between 5.6 and 26 hours. These data are not conclusive and further study is being done in the area, but for now it will be assumed that the maximum holding time is six hours for the Unnamed Creek drainage. This time is also within the recommended time given by the U.S. EPA in the Manual of Methods for Chemical Analysis of Water and Wastes, 1974.

Mention is made that EM-1 represents an "average"; water quality will vary somewhat from one tributary to another. To define this variation, both insitu pH readings and lab readings will be taken. These are being compiled in Table 2. As of yet, there is insufficient data to show any shifts occurring in  $<6$  hours. Data will continue to be collected and if a significant shift is found before 6 hours, the holding time for that site will be adjusted accordingly.

US Steel bulk sample site pH stability was also tested (Table 3). The mean percent variation for 45 minutes was 1.9 percent and mean unit variation of 1.1. This type of shift is not within acceptable tolerance limits. Therefore, all pH readings are taken insitu at this site.

Table 2. pH Stability

<u>Site</u>	<u>Date</u>	<u>Time</u>	<u>Hours</u>	<u>pH</u>	<u>Units Difference from Insitu</u>	<u>% Variation from Insitu</u>	
Em-1	8/12/76	1600	--	7.55	--	--	
	8/12/76	1645	.08	7.50	.05	.66	
	8/26/76	1500	---	7.36	--	---	
	8/27/76	0900	18	7.95	.59	.25	
	9/8/76	2030	---	EM-7	7.90	}doubles .10	---
				EM-1	7.90		
	9/9/76	0945	13	EM-7	7.90	}doubles .10	---
				"	7.80		
	9/16/76	1215	--	7.85	--	--	
	9/17/76	0830	21	7.98	.13	1.6	
Em-3	8/26/76	Insitu					
		1135	--	7.82	---	---	
	8/27/76	0910	16.7	8.09	.27	3.3	
	9/8/76	Insitu					
1245		--	8.30	---	---		
		1455	2.2	8.19	-.11	1.4	
Em-4	7/15/76	Insitu					
		0855	---	6.40	---	---	
		1600	7	6.62	.22	3.3	
	8/9/76	Insitu					
		1120	--	7.80	---	---	
		1400	2.7	7.55	-.25	3.2	
	8/26/76	Insitu					
1135		--	7.41	---	---		
8/27/76	0915	21	7.42	.01	1.3		
Em-5	7/2/76	0915	--	7.35	---	---	
	7/3/76	1440	31	7.40	.05	.60	
	8/26/76	Insitu					
		0920	--	7.80	---	---	
	8/27/76	0920	24	7.98	.18	2.2	
	9/8/76	Insitu					
		0830	--	8.10	---	---	
		1420	6	8.20	.10	1.2	
10/5/76	0940	---	7.70	---	---		
10/6/76	1330	28	7.96	.26	3.3		



### Alkalinity General

The Potentiometric method is used for determination of alkalinity. The pH is adjusted to an endpoint of 5.1 for total alkalinities  $\leq 30$  mg/l  $\text{CaCO}_3$ , to pH 4.5 for  $<150$  mg, to pH 4.2 for  $<500$ .

### Alkalinity Precision

Seven pairs of doubles were analyzed in the lab from Unnamed Creek on varying dates from July 1, 1976 through October 5, 1976 (Table 4). The variation ranged from 0 percent to 2.8 percent, the median being 1.7 percent and mean of 1.5 percent. A three percent variation in alkalinity between identical samples is expected. This variation is quite large, a more accurate buret will be used for this parameter soon, which will increase the precision of the titration; hopefully reducing the percent variation.

### Alkalinity Stability

Because of the extreme climate conditions in the Ely area, it is very difficult, if not impossible, to perform accurate titrations in the field on a routine basis. Therefore, it is extremely desirable to titrate in the laboratory. However, alkalinities are known to be somewhat unstable when stored. In order to determine stability for the US Steel and Unnamed Creek area, a stability test was performed.

EM-1 is considered an "average" representation of Unnamed Creek and represents the outflow of the watershed. A titration was made in the field immediately after sampling the site (EM-1 @1135) and the other titrations, from the same sample, were made in varying times up to 4.2 hours after first titration (Table 5, A). The percent variation from the first

Table 4. Alkalinity Precision.

Site	Date	Mg/l CaCO <sub>3</sub>	Total Variation	% Variation
Em-4	7/1	26.8 26.2	0.6	2.2
Em-9	7/15	132 135	3.0	2.2
Em-2	8/12	98.8 96	2.8	2.8
Em Seep 3	8/26	99 100	1.0	1.0
Em-1	9/8	117 119	2.0	1.7
Em Seep 1	9/21	220 220	0	0
Em Seep 1	10/5	213 214	1.0	0.4

Table 5. Alkalinities stability with time.

(A)	Site	Date/Time	Hours Titrated	mg/l CaCO <sub>3</sub>	Total Variation	% Variation
	Em-1	8-10-76/1135	Immediately	106	---	---
	"	" /1138	.05	103	-3	2
	"	" /1145	.12	105	-1	1
	"	" /1315	1.7	110	-4	4
	"	" /1324	1.8	107	1	1
	"	" /1330	1.9	104	-2	2
	"	" /1525	3.83	104	-2	2
	"	" /1535	4.0	104	-2	2
	"	" /1540	4.2	104	-2	2
(B)	USS	8-10-76/1035	Immediately	1.0	---	---
	"	/1045	.17	1.0	0	0
	"	/1050	.25	1.0	0	0
	"	/1500	4.42	1.0	0	0

Conductance variation with time.

EPA Barnstead.

<u>Location</u>	<u>Date/Time</u>	<u>Hours</u>	<u>Specific Conductance</u>	<u>Units Difference from Insitu</u>	<u>% Variation from Insitu</u>
Em-1	8-10-76/1210	--	566	---	---
	" /1215	.08	570	4	.70
	" /1216	.10	571	5	.87
	" /1217	.12	572	6	1.0
	8-11-76/1245	24.5	600	34	5.7
	" /1250	24.6	597	31	5.2
	" /1255	24.7	577	10	1.9
	8-27-76/1435	--	694	---	---
	" /1500	.42	694	1	1.0
US Steel	8-11-76/1230	--	366	---	---
	" /1233	.05	365	.27	1
	" /1235	.08	362	1.1	4
	" /1320	.83	342	6.6	24
	" /1322	.87	363	.82	3
	" /1323	.88	363	.82	3

Unnamed Creek conductance at site Em-1 varied from .70 percent to 5.7 percent in a maximum time period of 24.7 hours. However, the maximum variation did not occur at 24.7 hours, but at 24.5 hours. The variation here, assuming the Barnstead meter could vary up to  $\pm 7.0$  percent, is within the precision limits of the meter. Therefore, the assumption is made that up to 24 hours, Unnamed Creek specific conductance does not change measurably.

The US Steel data is, at present, insufficient to be statistically significant. More data will be collected.

Table 3.

<u>Station</u>	<u>Date</u>	<u>Specific Conductance Atmos/cm</u>	<u>Units Difference from Insitu</u>	<u>% Variation from Insitu</u>
Em-1	8/10/76	566 571	---	---
"	"	571 572	5	.87
"	9/8/76	655 651	---	---
Em-8	7/27/76	1811 1950	6.0	.91
Em-9	7/15/76	2079 1718	---	---
Em Seep 1	9/21/76	3809 3703	93	5.1
Em Seep 3	8/24/76	1945 2569	---	---
USS	7/29/76	349 346	624	24.0
USS	8/11/76	366 365	3	.86
			1	.27

DISSOLVED OXYGENGeneral

Dissolved oxygen is not a critical parameter. The objective for taking it is to determine the relative presence or absence of oxygen in the water as it relates to the abundance of aquatic life in the stream. There are two methods used, in the leaching program, to determine dissolved oxygen:

1. The Hach Chemical Company azide modification of the winkler method; and
2. Yellow Springs Instrument (YSI) model 54 dissolved oxygen meter.

To determine the precision of the Hach method, eight samples were taken from the US Steel pit between 0945-1005 on August 11, 1976 (Table 6). These were acidified in the field and titrated in the lab. The percent variation from the mean was .66 percent.

Since the YSI meter was obtained on September 1, 1976, it has been calibrated three times just prior to sampling the calibration. Check results were:

Date	Winkler mg/l dissolved oxygen	YSI Reading	% Variation
9/7/76	8.1	8.2	1.2
9/20/76	8.5	8.5	0
9/29/76	8.9	8.7	2.24

The method of calibration is described in the procedure section. These figures are not yet statistically significant. However, if the instrument performs as well in the field, the variation should be under five percent. Further study will be made this spring on the precision and accuracy of this instrument.

In summary, the acceptable variation for dissolved oxygen, for the leaching program, will be  $\pm 5$  percent. A precision below  $\pm 2$  percent with the Hach winkler method has been observed to date. This is well under the five percent limit. However, further data are being obtained on this method. The precision of the YSI meter is  $\pm 3$  percent; as of yet, this is not statistically significant and further study on this is being made.

APPENDIX III

FLOW DATA

UNITED STATES  
DEPARTMENT OF THE INTERIOR  
GEOLOGICAL SURVEY  
WATER RESOURCES DIVISION

1976

Station Number FM-1

Used rating table dated 7 Dec 76

Gage Read to Once a Day by Twice

Gage heights used to half tenths between \_\_\_\_\_ and \_\_\_\_\_ feet  
hundredths below and tenths above these limits.

APRIL		MAY		JUNE		JULY		AUGUST		SEPTEMBER		DAY	THIRD	FOURTH	Date
Gage height	Discharge	Gage height	Discharge	Gage height	Discharge	Gage height	Discharge	Gage height	Discharge	Gage height	Discharge				
								6.39	s	2.0		13			
								6.58	s	2.5		13			
								7.23	s	5.4		14			
								7.54	s	7.4		14			
								7.25	s	5.5		15			
								6.37	s	1.9		15			
								7.65	s	4.6		15			
								6.95	s	4.4		16			
								7.10	s	5.0		16			
								6.44	s	2.2		17			
								6.14	s	1.2		17			
								7.42	s	6.8		18			
								7.67	s	8.3		18			
								6.81	s	3.9		19			
								6.72	s	3.2	7.06	19			
						6.48	s	2.3	7.48	7.0	6.23	19			
						6.85	s	4.2	6.72	3.8	6.00	20			
						6.41	s	2.1	7.11	4.9	6.50	20			
						6.66	s	3.1	6.07	1.2	6.11	21			
						7.03	s	4.6	7.03	4.5	6.89	21			
						6.78	s	3.7	6.81	3.9	6.43	22			
						6.73	s	3.2	6.52	2.5	6.08	22			
						6.99	s	4.4	6.69	3.2	5.78	23			
						6.45	s	2.1	6.30	1.8	6.73	23			
						6.19	s	1.4	5.95	0.9	6.13	24			
						6.13	s	1.3	6.65	2.8	6.98	24			
						6.13	s	1.3	6.56	2.6	6.27	25			
						7.17	s	5.2	6.40	2.0	6.52	25			
						7.33	s	6.0	↑		6.61	26			
						7.50	s	7.1			5.75	26			
						6.48	s	2.4				27			
												28			
												29			
												30			
												31			

recorder inoperative (clock stopped)

Computed

Disch. applied

G. II. copied

PERIOD YEAR





MINE DEWATERING

Continuation with Line

RECEIVING SYSTEM

MONTH JUNE 1975

130

UNNAMED				CREEK				7-21-75	
AREA 8				AREA 8					
OH				012					0.5 ft Completed 8:40 PM
B-4				B-6					
GALLONS PER MINUTE	HOURS PER DAY RUN	TOTAL GALLONS PER DAY	CFS (mean daily)	GALLONS PER MINUTE	HOURS PER DAY RUN	TOTAL GALLONS PER DAY	CFS (mean daily)		
2242	9.5	1277940	2.0	368	22.5	422000	0.8		
472	2	56640	0.09						
3185	13.0	2679820	4.2	287	17.5	301350	0.5		
2714	11.5	1872660	2.9						
2242	9.5	1277940	2.0						
2360	10	1416000	2.2	49	3	8820	0.01		
2303	14	2774520	4.3	393	24	565920	0.9		
				225	24	324000	0.5		
1416	6	599760	0.8	150	16	144000	0.2		
3421	14.5	2976270	4.6	225	24	324000	0.5		
4719	20	5662200	8.9	169	18	182520	0.3		
				225	24	324000	0.5		
4601	19.5	5383170	8.3						
5545	23.5	7818450	12.1	89	9.5	50730	0.08		
5663	24	8154720	12.6						
63	24	8154720	12.6	150	16	144000	0.2		
663	24	8154720	12.6	225	24	324000	0.5		
3775	16	3624000	5.6	188	20	225600	0.3		
3775	16	3624000	5.6						
826	3.5	173460	0.3	225	24	324000	0.5		
5663	24	8154720	12.6	225	24	324000	0.5		
5663	24	8154720	12.6	225	24	324000	0.5		
708	3	127440	0.2						
2242	9.5	1277940	2.0	28	3	5040	0.008		
				169	18	182520	0.3		
2950	12.5	2212500	3.4	225	24	324000	0.5		
2832	12	2924040	3.2	188	20	225600	0.3		
		8745390				5124900			
		3613925	5.6			256245			

MINE DEWATERING  
RECEIVING SYSTEM

MONTH AUGUST 1976

UNNAMED				CREEK			
AREA				AREA B			
011				012			
8-4				8-6			
GAUGES PER MINUTE	HOURS PER DAY RUN	TOTAL GALLONS PER DAY	CF5 WAYS DAILY	GAUGES PER MINUTE	HOURS PER DAY RUN	TOTAL GALLONS PER DAY	CF5 MEDIAN DAILY
1	3,999	11	2,639,340				
2	3,999	24	5,758,560				
3	3,999	24	5,758,560	636	19	425,040	1.1
4	3,999	16.5	3,959,010	256	24	368,640	0.6
5	3,999	4	959,760	256	8	122,880	0.2
6	3,999	18	4,318,920				
7	3,999	15.5	3,719,070				
8	3,999	17	4,078,980				
9	3,999	5	1,199,700				
10							
11	3,999	23	5,518,620	256	24	368,640	0.6
12	3,999	24	5,758,560	256	14.5	222,720	0.4
13	3,999	12	2,878,260	256	24	368,640	0.6
14	3,999	9.5	2,279,430	256	24	368,640	0.6
15	3,999	24	5,758,560	256	24	368,640	0.6
16	3,999	6.5	1,559,610	256	24	368,640	0.6
17	3,999	20	4,798,800	256	24	368,640	0.6
18				256	14	215,040	0.3
19	3,999	20	4,798,800	256	16	245,760	0.4
20	3,999	13	3,119,220	256	24	368,640	0.6
21	3,999	11.5	3,599,210	256	24	368,640	0.6
22	3,999	8	1,919,520	171	24	246,240	0.4
23	3,999	8	1,919,520	171	24	246,240	0.4
24							
25	3,999	12.5	2,999,250	171	24	246,240	0.4
26	3,999	6	1,439,680	171	16	164,160	0.3
27	3,999	9.5	2,279,430	171	19	194,940	0.3
28				171	24	194,940	0.3
29	3,999	24	5,758,560	171	4	41,040	0.1
30							
31	3,999	15.5	3,719,070				
T		38.2	59,297,680	516.1	423	6,183,000	
AVE		14.7	3,432,988	245.7	20	294,429	0.5

APPENDIX IV  
ERROR ESTIMATES

Errors in flow are based on the experience and judgement of the person taking the measurement. A sample discharge sheet is shown in Figure 16. Each measurement is rated as to its reliability when it is taken. Additional work will be conducted to better define flow measurement error.

Table I. Errors in flow measurement (Percent error)

Station #	Flow Regime		
	Low	Midrange	High
EM-1	<-----	±8%	----->
EM-3	<-----	±8%	----->
EM-8	<-----	±5%	----->
EM-5	±8%		±10%
EM-2	±8%		±10%
Seep 3	±10%	±8%	±5%
Seep 1	<-----	±10%	----->

The error in the load is given by the error in the concentration plus the error in the flow measurement.

Table II

Parameter: Other (Cd-T)

Date	Station	$X_1$	$X_2$	Average $\bar{X}$	Difference $ X_1 - X_2 $	% Error $\frac{ X_1 - X_2 }{\bar{X}} \times 100$
9/21	Seep 1	.132	.136	.134	.004	±2.99

Table IV

Parameter: Zn T

Date	Station	X <sub>1</sub>	X <sub>2</sub>	Average $\bar{X}$	Difference $ X_1 - X_2 $	% Error $\frac{ X_1 - X_2 }{\bar{X}} \times 100$
7/19	EM-8	.020	.018	.019	.002	±10.53
8/26	Seep 3	.330	.335	.333	.005	±15.02
9/21	Seep 1	.125	.125	.125	0	0
						$\Sigma$ 25.55
						$\bar{e} = 8.52$

Table VI

Parameter: Fe F

Date	Station	X <sub>1</sub>	X <sub>2</sub>	Average X	Difference  X <sub>1</sub> - X <sub>2</sub>	% Error
						$\frac{ X_1 - X_2 }{X} \times 100$
7/1	EM-4	.535	.755	.645	0.22	±34.11
7/15	EM-9	.066	.063	.065	.003	±4.62
7/27	EM-8	.050	.045	.048	.005	±10.42
8/12	EM-2	.022	.022	.022	0	0
9/21	Seep 1	5.96	5.70	5.83	0.26	±4.46
						$\Sigma$ 53.61
						$\bar{e} = 10.72$



Table VIII

Parameter: Alkalinity

Date	Station	X <sub>1</sub>	X <sub>2</sub>	Average $\bar{X}$	Difference $ X_1 - X_2 $	% Error
						$\frac{ X_1 - X_2 }{\bar{X}} \times 100$
7/1	EM-4	26.8	26.2	26.50	0.6	±2.26
7/15	EM-9	132	135	133.50	3	±2.25
8/12	EM-2	98.8	96	97.40	2.8	±2.87
8/26	Seep 3	99	100	99.5	1.0	±1.01
9/8	EM-1	117	119	118	2	±1.69
9/21	Seep 1	220	220	220	0	0
10/5	?Seep 3	213	214	213.5	1	±0.47
						$\Sigma 10.55$
						$\bar{e} = 1.51$

Table X

Parameter: Hardness

Date	Station	X <sub>1</sub>	X <sub>2</sub>	Average $\bar{X}$	Difference $ X_1 - X_2 $	% Error
						$\frac{ X_1 - X_2 }{\bar{X}} \times 100$
7/1	EM-4	36	36	36	0	0
7/15	EM-9	1113	1052	1082.5	61	±5.64
7/27	EM-8	1348	1345	1346.50	3	±0.22
8/12	EM-2	505	505	505	0	0
						$\Sigma 5.68$
						$\bar{e} = 1.42$

Table XII

Parameter: Cl

Date	Station	X <sub>1</sub>	X <sub>2</sub>	Average $\bar{X}$	Difference $ X_1 - X_2 $	% Error
						$\frac{ X_1 - X_2 }{\bar{X}} \times 100$
7/1	EM-4	1.31	1.20	1.26	0.11	±8.73
7/15	EM-9	39.1	38.7	38.90	0.40	±1.03
7/27	EM-8	45.3	42.7	44.0	2.60	±5.91
8/12	EM-2	58.1	63.4	60.75	5.30	±8.72
8/26	Seep 3	38.5	36.0	37.25	2.5	±6.71
9/8	EM-1	29.5	29.5	29.5	0	0
9/21	Seep 1	36.3	35.5	35.90	0.80	±2.23
						$\Sigma$ 33.33
						$\bar{e} = 4.76$

Table XIV

Parameter: DOC

Date	Station	X <sub>1</sub>	X <sub>2</sub>	Average X	Difference  X <sub>1</sub> -X <sub>2</sub>	% Error
						$\frac{ X_1 - X_2 }{X} \times 100$
7/1	EM-4	27.7	28.0	27.85	0.3	±1.08
7/15	EM-9	26.0	27.7	26.85	1.7	±6.33
7/27	EM-8	20.0	19.5	19.75	0.5	±2.53
8/12	EM-2	16.4	20.9	18.65	4.50	±24.13
8/26	Seep 3	23.8	23.8	23.8	0	0
9/8	EM-1	28.1	27.7	27.90	0.40	±1.43
9/12	Seep 1	23.5	23.0	23.25	0.5	±2.15
						$\Sigma$ 37.65
						$\bar{e} = 5.38$

Table XVI

Parameter: Cu T

<u>Low Range</u>				% Error		
Date	Station	X <sub>1</sub>	X <sub>2</sub>	Average $\bar{X}$	Difference $ X_1 - X_2 $	$\frac{ X_1 - X_2 }{\bar{X}} \times 100$
7/1	EM-4	.005	.001	.003	.004	±133
7/15	EM-9	.014	.023	.019	.009	±47.37
7/27	EM-8	.019	.013	.016	.006	±37.5
8/12	EM-2	.007	.006	.0065	.001	±15.38
9/8	EM-1	.004	.004	.004	0	0
9/21	Seep 1	.091	.012	.051	.079	±155
						$\Sigma 387.5$
						$\bar{e} = 64.5$

High Range

8/26	Seep 3	.617	.617	.617	0	0
------	--------	------	------	------	---	---

Table XVIII

Parameter: NJ TLow Range

Date	Station	X <sub>1</sub>	X <sub>2</sub>	Average X	Difference  X <sub>1</sub> -X <sub>2</sub>	% Error
						$\frac{ X_1-X_2 }{X} \times 100$
8/12	EM-2	.044	.049	.0465	.005	±10.75
9/8	EM-1	.123	.130	0.1265	.007	±5.53

High Range

7/15	EM-9	1.66	1.61	1.64	.05	±3.05
7/27	EM-8	2.00	1.97	1.985	.03	±1.51
8/26	Seep 3	19.8	19.2	19.5	0.6	±3.08
9/21	Seep 1	.872	.884	.878	.012	±1.37
						$\Sigma 26.29$
						$\bar{e} = 4.38$

Table XX

Parameter: Fe T

Date	Station	X <sub>1</sub>	X <sub>2</sub>	Average $\bar{X}$	Difference $ X_1 - X_2 $	% Error
						$\frac{ X_1 - X_2 }{\bar{X}} \times 100$
7/1	EM-4	1.12	1.11	1.115	.01	±0.90
7/15	EM-9	.175	.179	0.177	.004	±2.26
7/27	EM-8	.090	.099	.0945	.009	±9.52
8/12	EM-2	.056	.066	.061	.01	±16.39
8/26	Seep 3	.733	.752	.7425	.019	±2.56
9/8	EM-1	.155	.174	0.1645	.0190	±11.55
9/21	Seep 1	7.07	7.20	7.1350	0.13	±1.82
						$\Sigma 45.0$
						$\bar{e} = 6.43$

APPENDIX V  
CALCULATIONS FOR WATER  
STORAGE IN STOCKPILE



APPENDIX . Seep 3 Calculation

Is there sufficient holding capacity in the stockpile to provide water for the flow at Seep 3?

Average discharge of  $\sim .1$  cfs  
time - 100 days

Total volume  $.1$  cfs  $\times$  100 days = 10 sfd

or  $(10 \text{ sfd}) \left(\frac{1}{2} \text{ acre ft/sfd}\right) = 5 \text{ acre feet}$

An estimate of the flat area in the stockpile is:

$$600' \times 600' = \frac{36 \times 10^4 \text{ ft}^2}{4.36 \times 10^4 \text{ ft}^2/\text{acre}} \approx 8.25 \text{ ft.}$$

or there would only have to be approximately 7 inches of water over this area to provide adequate water for flow.

APPENDIX VI  
WATER QUALITY DATA

WATER QUALITY DATA  
 Unnamed Creek Site EM-1

	7-1-76	7-15-76	7-27-76	8-12-76	8-26-76	9-8-76	9-21-76
pH	7.5	7.5	7.59	7.55	7.36	7.9	8.0
Alkalinity (mg/l as CaCO <sub>3</sub> )	76	92	113	97	105	117	109
Specific Conductance (umhos/cm)	393	905	787	604	694	775	600
Dissolved Oxygen	8.6		7.8	7.95	8.6	8.3	8.9
Temperature (°C)	18	20		17	19.1	12.2	8
Silica	8.63	9.04	9.24			9.22	9.95
Chloride	31.9	52.3	43.2	32.3	20.9	29.5	27.5
Sulfate	249	323	445	180	243	242	277
Dissolved Organic Carbon	12.7	17.0	18.5	27.4	21.0	28.1	10.0
Dissolved Inorganic Carbon	19.2	13.4	18.0	13.7	14.2	9.4	27.0
Copper, Total	.004	.006	.007	.004	.003	.004	.002
Copper, Filtered	.004	.005	.006	.003	.003	.004	.001
Nickel, Total	.106	.161	.171	.087	.105	.130	.100
Nickel, Filtered	.108	.158	.170	.082	.095	.105	.110
Iron, Total	.260	.161	.250	.171	.175	.155	.151
Iron, Filtered	.239	.121	.109	.135		.084	.101
Calcium, Total	40.7	47.9	69.5	41.2	42.3	51.3	45.8
Zinc, Total							
Zinc, Filtered							
Cobalt, Total							.001
Discharge (ft <sup>3</sup> /sec)		1.68	1.01	8.08	2.93	2.49	.97
Other							
Hardness	322	470	635	285	parameter deleted		

Blanks mean no analysis  
 All parameters in mg/l unless noted

WATER QUALITY DATA  
 Unnamed Creek Site EM-3

	7-1-76	7-15-76	7-27-76	8-12-76	8-26-76	9-8-76	9-21-76
pH	7.5	7.5	7.70	7.71	7.82	8.3	8.1
Alkalinity (mg/l as CaCO <sub>3</sub> )	84	93	97	88	104	102	106
Specific Conductance (umhos/cm)	410	910	847	500	725	467	617
Dissolved Oxygen	8.6	8.5	9.4	7.05	8.3		11.0
Temperature (°C)	16.5	16		19.5	17.5	16	9.3
Silica	9.17	10.1	10.33			9.35	9.10
Chloride		56.9	35.1	33.9	22.5	25.7	24.0
Sulfate	331	473	317	122	215	157	63.0
Dissolved Organic Carbon	10.5	20.3	16.5	17.4	21.0	24.6	7.5
Dissolved Inorganic Carbon	21.1	11.0	15.5	13.0	14.4	9.1	18.0
Copper, Total	.005	.006	.006	.003	.003	.003	.002
Copper, Filtered	.004	.007		.003	.003	.005	.003
Nickel, Total	.194	.360	.422	.099	.194	.110	.127
Nickel, Filtered	.081	.352		.095		.098	.154
Iron, Total	.120	.116	.268	.078	.098	.071	.097
Iron, Filtered	.082	.059		.035	.081	.038	.033
Calcium, Total	47.2	65.4	55.4	34.6	46.0	30.6	39.4
Zinc, Total							
Zinc, Filtered							
Cobalt, Total							.002
Discharge (ft <sup>3</sup> /sec)		1.12	1.48	6.52	1.43	2.41	3.74
Other							
Hardness	358	461	435	225	parameter deleted		

Blanks mean no analysis  
 All parameters in mg/l unless noted

WATER QUALITY DATA  
 Unnamed Creek Site EM-5

	7-1-76	7-15-76	7-27-76	8-12-76	8-26-76	9-8-76	9-21-76
pH	7.35	7.41	7.5	7.89	7.80	8.1	7.55
Alkalinity (mg/l as CaCO <sub>3</sub> )	103.2	101	97	92	108	105	107
Specific Conductance (umhos/cm)	496	1020	492	396	1280	529	760
Dissolved Oxygen	7.8	8.0	7.6	8.0	8.1		10.2
Temperature (°C)	14	14.0	16	17.0	14.1	15.2	8.0
Silica	5.24	9.72	10.36			11.2	10.1
Chloride	38.2	34.1	49.9	32.3	20.6	24.0	20.9
Sulfate	339	401	132	86.3		37.7	236
Dissolved Organic Carbon	9.7	18.3	15.5		17.3	24.1	8.5
Dissolved Inorganic Carbon	25.8	14.4	15.5		14.4	8.2	25.0
Copper, Total	.011	.012	.010	.006	.008	.006	.005
Copper, Filtered	.010	.010	.005	.004	.008	.004	.005
Nickel, Total	.425	.789	.036	.053	.791	.051	.346
Nickel, Filtered	.420	.663	.023	.046	.666	.049	.356
Iron, Total	.186	.078	.195	.286	.067	.163	.097
Iron, Filtered	.095	.025	.087	.034	.023	.034	.034
Calcium, Total	58.9	78.2	10.0	29.7	92.0	23.3	59.5
Zinc, Total			.010				
Zinc, Filtered			.010				
Cobalt, Total							.005
Discharge (ft <sup>3</sup> /sec)	.7	.5	6.25	7.25	.3	6.3	.8
Other							
Hardness	432	532	218	188	parameter deleted		

Blanks mean no analysis  
 All parameters in mg/l unless noted

WATER QUALITY DATA  
 Unnamed Creek Site EM-8

	7-1-76	7-6-76	7-15-76	7-19-76	7-26-76	7-27-76	8-12-76	8-26-76	9-8-76	9-21-76
pH	7.2	7.1	7.2	7.15	7.09	7.01	7.10	7.4	7.4	7.65
Alkalinity (mg/l as CaCO <sub>3</sub> )	103	136	128	133	129	133	124	130	150	145
Specific Conductance (microhm/cm)	629		1695	1846	1980	2080	2250	2680	2600	2740
Dissolved Oxygen		8.5 8.2	8.1	7.3	6.6	6.0 6.4	6.75	7.3	NT	7.9
Temperature (°C)		11.0	13.5	10.0	10.0	6.0	11.5	8.5	8.0	3.0
Silica	8.77	8.80	9.99	9.61	9.34	9.89				13.0
Chloride	34.1	41.2	39.1	40.7	43.9	45.3	56.5	29.2		38.0
Sulfate	708	714	980	1134	1203	1237	1346	1564	1685	1523
Dissolved Organic Carbon	14.5	24.5	26.0	26.3	19.0	20.0	21.4	26.5	36.3	11.5
Dissolved Inorganic Carbon	32.9	21.5	15.7	19.0	24.5	26.5	17.4	19.5	10.3	37.5
Copper, Total	.017	.018	.020	.016	.016	.109	.021	.018	.017	.020
Copper, Filtered	.016	.015	.018	.015	.015	.018	.020	.016	.016	.016
Nickel, Total	.963	1.35	1.60	.580	1.89	1.97	2.40	2.36	2.42	2.42
Nickel, Filtered	.950	.498	1.56	.570	1.94	2.10	2.40	2.40	2.40	2.56
Iron, Total	.194	.155	1.66	.114	.114	.090	.134	.095	.139	.203
Iron, Filtered	.102	.005	.058	.086	.073	.045	.045	.057	.072	.134
Calcium, Total	94.4	143	65.9	154	163	178	214	230	241	248
Zinc, Total					.020	.018	.035	.038	.037	.040
Zinc, Filtered					.020	.023	.031	.035	.035	.033
Cobalt, Total										.029
Discharge (ft <sup>3</sup> /sec)	.26	.21	.18	.17	.16	.16	.15	.12	.12	.12
Other			PO <sub>4</sub> -.019							
Hardness	807	918	1134		1195	1348	1310	parameter deleted		

All parameters in mg/l unless noted  
 Blanks mean no analysis

WATER QUALITY DATA  
 Unnamed Creek Site Secp 1

		7-1-76	7-15-76	7-27-76	8-12-76	8-26-76	9-8-76	9-21-76
pH			7.50	7.0	7.02	7.34	7.50	7.3
Alkalinity (mg/l as CaCO <sub>3</sub> )			161	184	190	188	227	220
Specific Conductance (umhos/cm)	D		3030	3330	2324	3818	3700	3810
Dissolved Oxygen	E		10.3	5.8	5.5			6.2
Temperature (°C)	L		.5		3.5	3.0	2.0	2.4
Silica	P		9.28	9.41			9.83	9.95
Chloride	N		48.6	49.8	84.3	29.3	40.7	36.3
Sulfate	A		2487	2555	1839	2190	2305	2004
Dissolved Organic Carbon	S		34.5	28.0	33.9	42.8	54.1	23.5
Dissolved Inorganic Carbon			20.7	35.5	27.6	25.2	23.4	56.0
Copper, Total	T		.050	.019	.029	.023	.022	.091
Copper, Filtered	O						.019	.009
Nickel, Total	N		1.92	1.24	1.40	1.10	0.98	.884
Nickel, Filtered							0.90	.845
Iron, Total	N		5.79	.710	3.15	3.8	3.65	7.07
Iron, Filtered	O						1.07	5.70
Calcium, Total	I			194	233		225	226
Zinc, Total	T			.258	.250	.250	.245	.125
Zinc, Filtered	A						.111	.101
Cobalt, Total	T							.132
Discharge (ft <sup>3</sup> /sec)	S		.06	.06	.06	.06	.06	.06
Other								
Hardness			3073	2998	1853	parameter deleted		

Blanks mean no analysis  
 All parameters in mg/l unless noted

WATER QUALITY DATA  
 Unnamed Creek Site Seep 3

	7-1-76	7-15-76	7-27-76	8-12-76	8-26-76	9-8-76	9-21-76
pH		6.91	6.80	7.1	7.50	7.55	7.25
Alkalinity (mg/l as CaCO <sub>3</sub> )		68	77	87	99	127	119
Specific Conductance (umhos/cm)		2400	2732	2610	3234	2800	2900
Dissolved Oxygen		11.9	11.9		11.2		9.6
Temperature (°C)		1.0		2.5	1.5	1.2	3.5
Silica		11.6	11.27			11.7	9.59
Chloride		62.0	58.9	70.4	38.5	57.5	50.1
Sulfate		1036	2001	2603	1539	1378	1628
Dissolved Organic Carbon		15.2	17.5	23.2	23.8	27.1	15.0
Dissolved Inorganic Carbon		9.0	10.0	27.0	13.7	12.1	31.0
Copper, Total		1.14		.753	.617	.637	.736
Copper, Filtered			1.88	.624	.588		.504
Nickel, Total		24.7		19.0	19.2	20.6	19.5
Nickel, Filtered			20.0	19.0	19.3		20.0
Iron, Total		.462		.605	.733	1.07	1.20
Iron, Filtered			.240	.139	.570		.346
Calcium, Total			226	260		242	253
Zinc, Total			.403	.350	.330	.338	.318
Zinc, Filtered				.385	.330		.329
Cobalt, Total							.857
Discharge (ft <sup>3</sup> /sec)		.145 e	0.12	.10	.10	.06	.05
Other							
Hardness		1280	2003	2865	parameter deleted		

e = estimate

All parameters in mg/l unless noted; blanks mean no analysis

Page 164



APPENDIX VII  
LOADING CALCULATIONS

## Zinc loads lbs/day

Date	EM-1	EM-3	EM-8	Seep 3	Seep 1	EM-2	EM-6
7-15							
7-27			0.016	0.261	0.083		
8-12			0.028	0.189	0.081		
8-26			0.024	0.178	0.081		
9-8			0.024	0.109	0.079		
9-21			0.026	0.086	0.040		
$\bar{x}$			0.024	0.165	0.073		

## Sulfate loads lbs/day

Date	EM-1	EM-3	EM-8	Seep 3	Seep 1	EM-2	EM-6
7-15	2924.83	2855.41	950.80	809.68	804.30	567.57	205.25
7-27	2476.97	2528.77	1066.79	1294.25	826.29	225.52	4037.49
8-12	7839.22	4287.42	1088.24	1403.02	594.73	646.80	2831.91
8-26	3837.63	1657.16	1011.60	829.52	708.25	416.54	75.68
9-8	3247.91	2039.41	1089.86	445.64	745.44	162.51	1065.93
9-21	1448.24	1269.99	985.08	438.75	648.09	123.32	
$\bar{x}$	3629.13	2439.69	1032.06	870.14	721.18	357.04	1643.25

APPENDIX VIII  
COMPUTER MODEL FOR 8/12/76

Figure VIII. EM-S, Inorganic Model

○	Cu(+2) 16.48	×	CuSO <sub>4</sub>	I	NiSO <sub>4</sub>
△	CuCO <sub>3</sub>	◇	Ni(+2) 4.39	.....	organic model
+	CuCO <sub>3</sub> S	↑	NiCO <sub>3</sub>	↓	Change due to introduction of organic ligands

(8-12-76)

⊠ measured pH

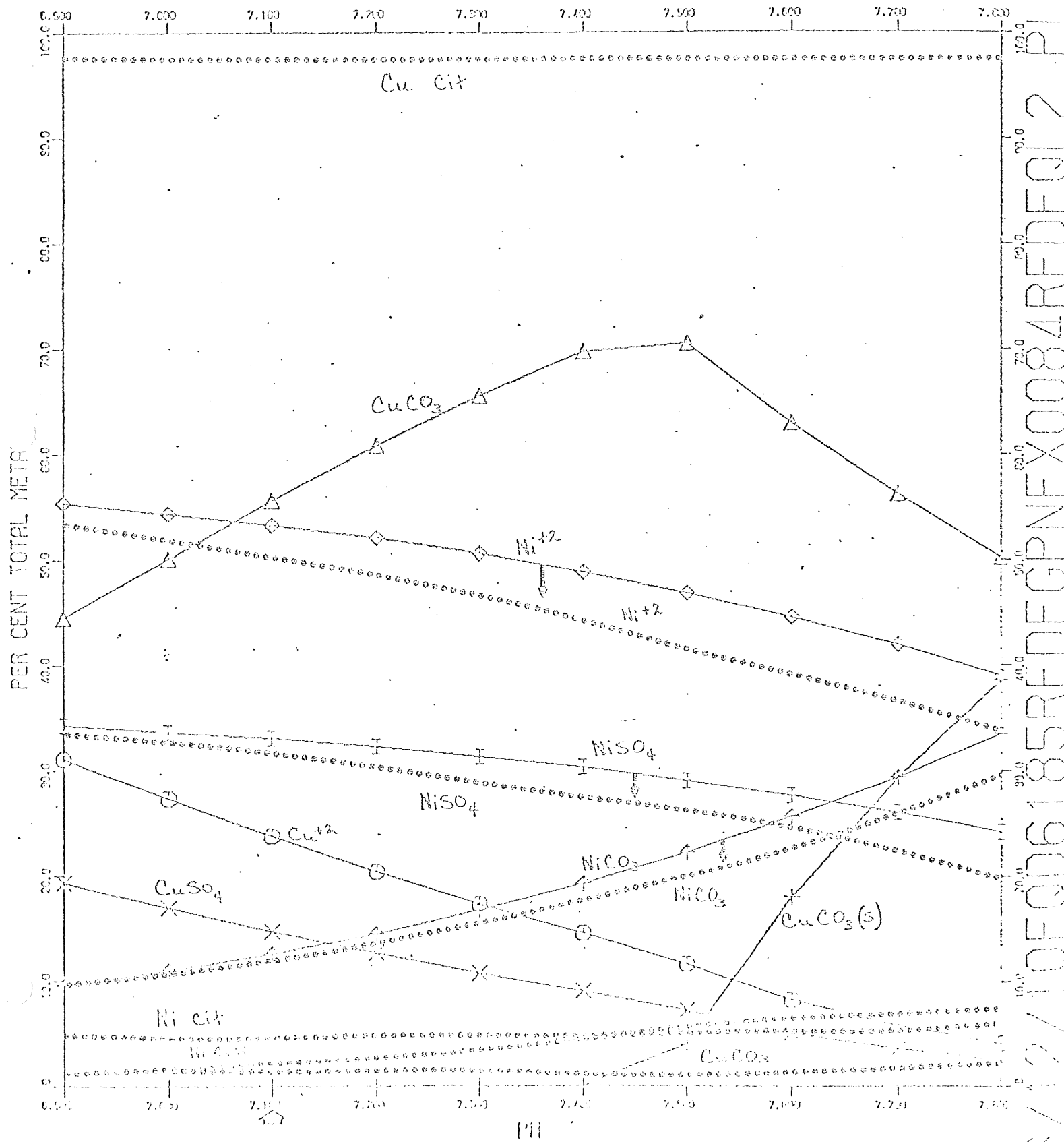

2/10F006185REDECPNEX0084REDEQL2 PLOTS EM-S

Figure 1X. IMS-3, Inorganic Model

- |   |                   |   |                     |
|---|-------------------|---|---------------------|
| ○ | Ni(+2) 3.49       | × | CuCO <sub>3</sub> S |
| △ | NiCO <sub>3</sub> | ◇ | CuCO <sub>3</sub>   |
| + | NiSO <sub>4</sub> | ↑ | Cu(+2) 4.93         |
- (8-12-76)

..... organic model  
 ↓ change due to introduction of organic ligands  
 ⊠ measured pH

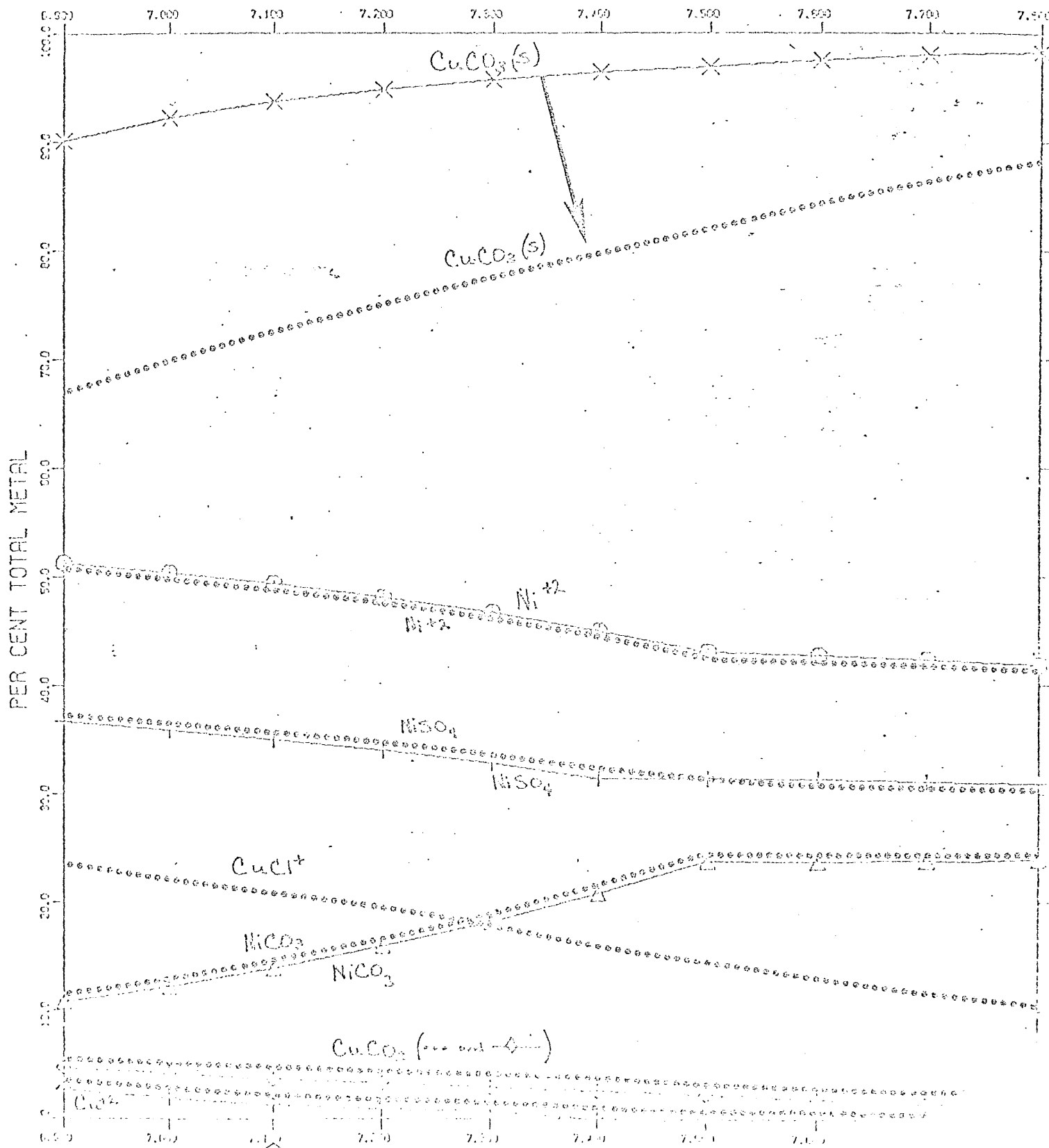

Figure X. EM-1, Inorganic Model

- $Cu^{+2}$  7.20 ×  $CuOH^+$  I  $NiSO_4$
  - △  $CuCO_3$  ◇  $Ni^{+2}$  5.83 ..... organic model
  - +  $CuSO_4$  ↑  $NiCO_3$  ↓ change due to introduction of organic ligands
- (8-12-76)
- ⊠ measured pH

