



TIMOTHY OULTON

A FRAME DINING TABLE 260X108CM ASSEMBLY INSTRUCTIONS

PARTS ENCLOSED :

- (A) [1] TABLETOP
- (B) [2] SIDE LEG

HARDWARE ENCLOSED :

NO.	ITEM	DESCRIPTION	QTY.
1		Bolt (M8 x 60mm)	8 pcs.
2		Spring Washer (10mm)	8 pcs.
3		Flat Washer (M8 x 18mm)	8 pcs.
4		Allen Key	1 pc.

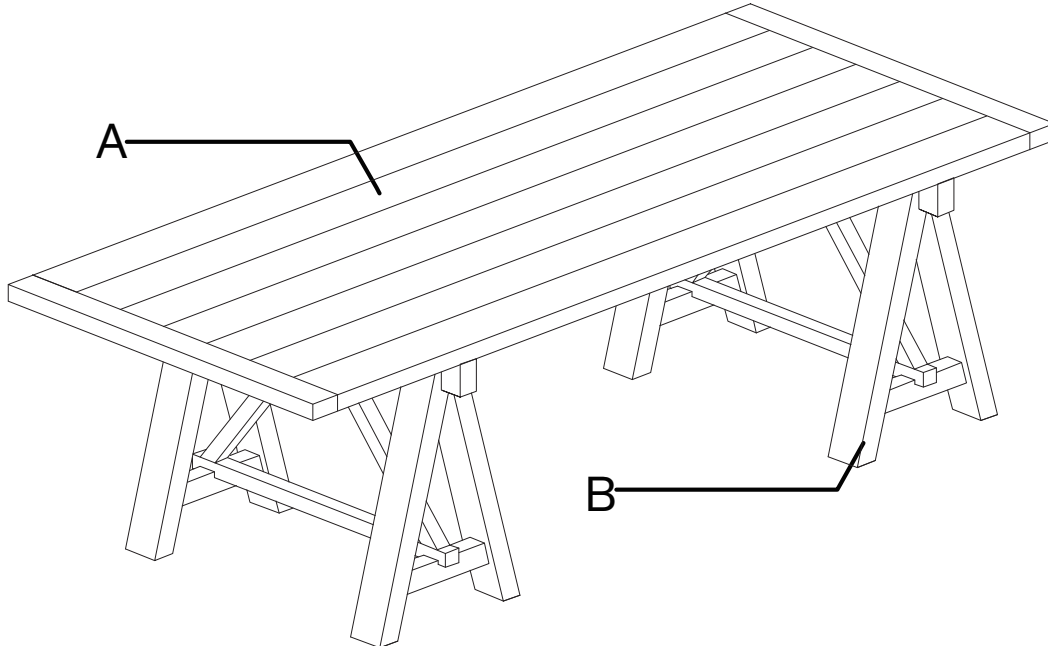



TIMOTHY OULTON

A FRAME DINING TABLE 260X108CM ASSEMBLY INSTRUCTIONS

Step 1:

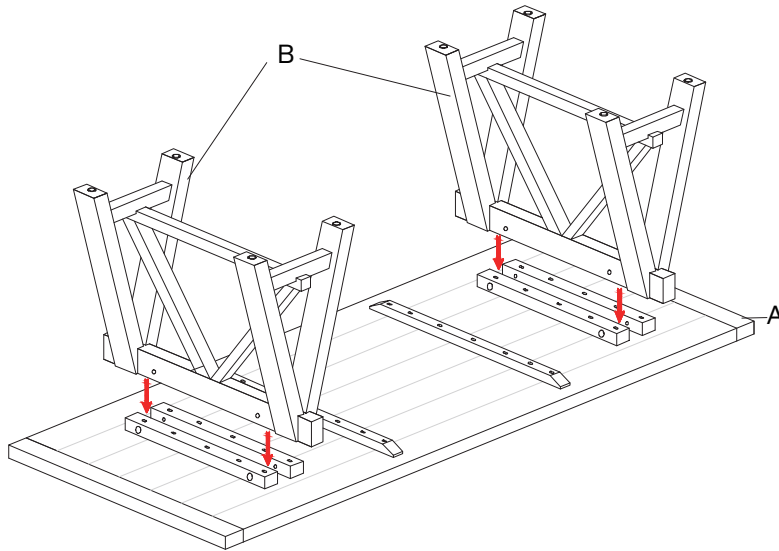

Step 2:

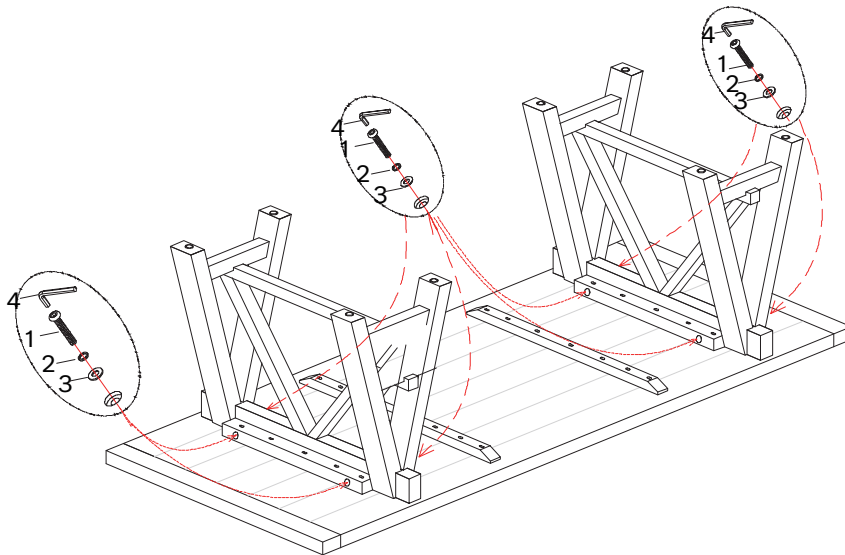

Step 2:

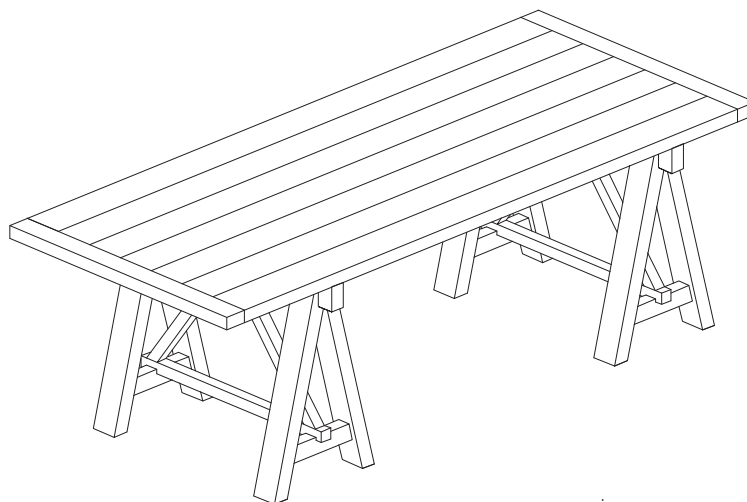



TIMOTHY OULTON

A FRAME DINING TABLE 260X108CM ASSEMBLY INSTRUCTIONS

IMPORTANT PLEASE READ

IMPORTANT SAFETY INSTRUCTIONS :

1. Exercise care and precaution when moving furniture as careless handling may cause injury and damage.
2. Never drag furniture. Always lift it.
3. Periodically check all fixtures to ensure none have come loose.
4. Re-tighten as and when necessary. Incorrect assembly of furniture can be dangerous. Re-tighten as and when necessary. Incorrect assembly of furniture can be dangerous.
5. Assembly should be carried out by competent personal.
6. No liability will be accepted for damage or injury caused by incorrect assembled furniture.
7. Heavy item warning.
8. Take care and seek assistance when lifting heavy furniture to avoid personal injury and or damage to product .

ASSEMBLY :

1. Carefully remove all parts from the box and remove all the plastic covering.
2. Please find the corresponding numbered parts before you assemble the table.
3. Upside down the tabletop (A) on a flat floor covered with protective material to prevent damage to tabletop (A).
4. Locate the side legs (B) to the tabletop (A) and secure using bolts (1), flat washers (3) and spring washers (2), then tighten with allen key (4) as illustration in step 1.
5. Adjust levelers if necessary and turn over the assembled table.
6. Assembly is complete.

CARE INSTRUCTIONS:

1. Use coasters or placemats to help prevent marks or stains.
2. Avoid mineral oil and red wine, as usage could discolor the wood.
3. Wipe the table clean with a soft, dry cloth after each use.

ENVIRONMENT:

1. Special waste handling may be required. Please contact your local authorities for more information.