

CARSONITE SUPPORT POST

CSP-XXXX-YY

This product is intended for use as an object marker and sign support post in sign applications requiring assured long-term outdoor durability, vandal resistance, and easy installation.

Ideal for signs up to 432 square inches (3 square feet).

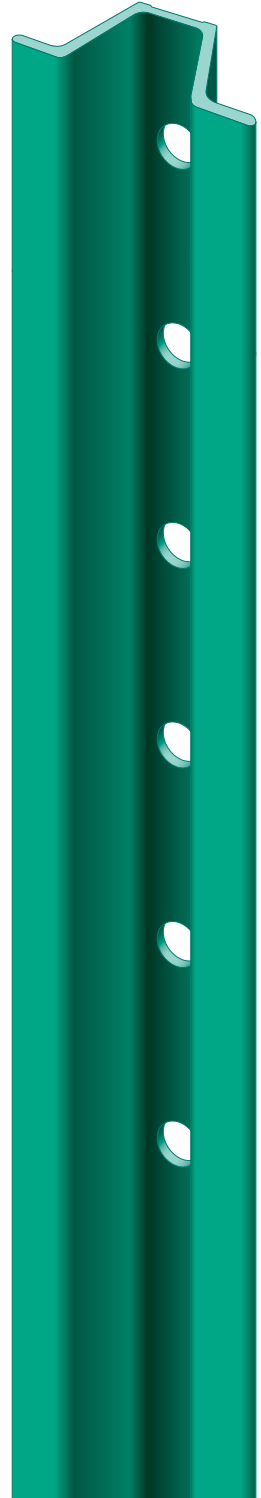

CSP-XXX-YY

PROPERTIES OF SUPPORT POST

PROPERTY	ASTM TEST METHOD	MINIMUM VALUE
Ultimate Tensile Strength	D-638	50,000 psi
Ultimate Compressive Strength	D-638	45,000 psi
Specific Gravity	D-792	1.7
Weight % Glass Reinforcement	D-2584	50%
Barcol Hardness	D-2583	47

Construction: Fiberglass Reinforced Composite

Weight: 0.95 lbs. per foot

Signage not included.

HOW TO ORDER:

CSP-	XXX-	YY
Product number	Length (in.)	Color (3 choices)

XXX	Length (in)	YY	Color
072	72	03	Brown
096	96	07	Green
120	120	09	Gray
144	144		



03 Brown



07 Green

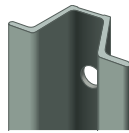

09 Gray

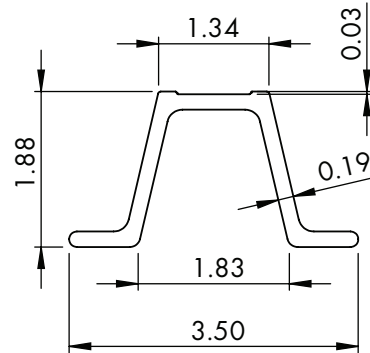

DETAIL A

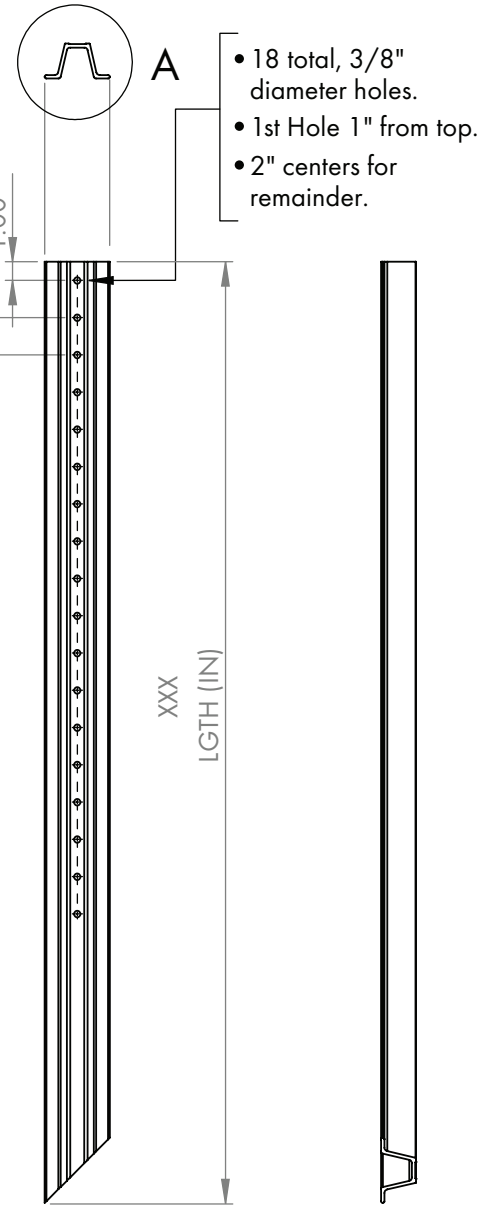

FASTENING DIAGRAM:

