



AcoustaShieldTM

SOUND BARRIER SYSTEM



Attractive, Durable **Composite Sound Walls**

*Sound-mitigation fencing with a
lightweight design for easy installation.*

*AcoustaShield sound barrier systems meet or exceed
AASHTO and DOT sound wall guidelines.*

AcoustaShield™

SOUND BARRIER SYSTEM

Carsonite AcoustaShield™ sound barrier systems provide highly effective noise abatement along transportation corridors. AcoustaShield is exceptionally lightweight compared to traditional sound walls. In fact, the fencing systems can be easily installed by a small crew without the use of heavy lifting equipment.

Designed and produced using fiberglass strands and mat, the composite material's maintenance-free construction saves time and money over the product's lifetime. In hot, humid environments, the AcoustaShield composite construction will never rust. Further the materials will not deteriorate in salt-air climates, desert heat, or harsh, high-traffic environments.

The attractive, graffiti-resistant design provides superb UV protection for long-term performance in the field.



AcoustaShield 12-inch high horizontal panels.

AcoustaShield Sound Barrier PRE-CONSTRUCTION BENEFITS

- Proven performance addresses sound absorption concerns in local communities
- Winner of Federal Highway Administration's Environmental Award of Excellence for Innovation
- Delivers remarkable decibel reduction per square foot per dollar performance
- Mitigation performance meets or exceeds AASHTO and many DOT sound wall guidelines
- No need for noisy, heavy equipment for wall installation
- Lightweight design reduces the number of delivery trucks needed and allows for easy storage near the job site
- Extremely fast installation
- Environmentally sound – no chemical preservatives, plus well suited for environmentally sensitive areas where heavy equipment may damage sensitive land



AcoustaShield 6-inch high horizontal panels.

- Valmont is a world leader in providing a variety of long-standing structures to commercial property owners, utilities, municipalities, transportation departments, and more.

See the AcoustaShield™ Difference

Layers of Innovation and Triple UV Protection for Long Lasting Durability

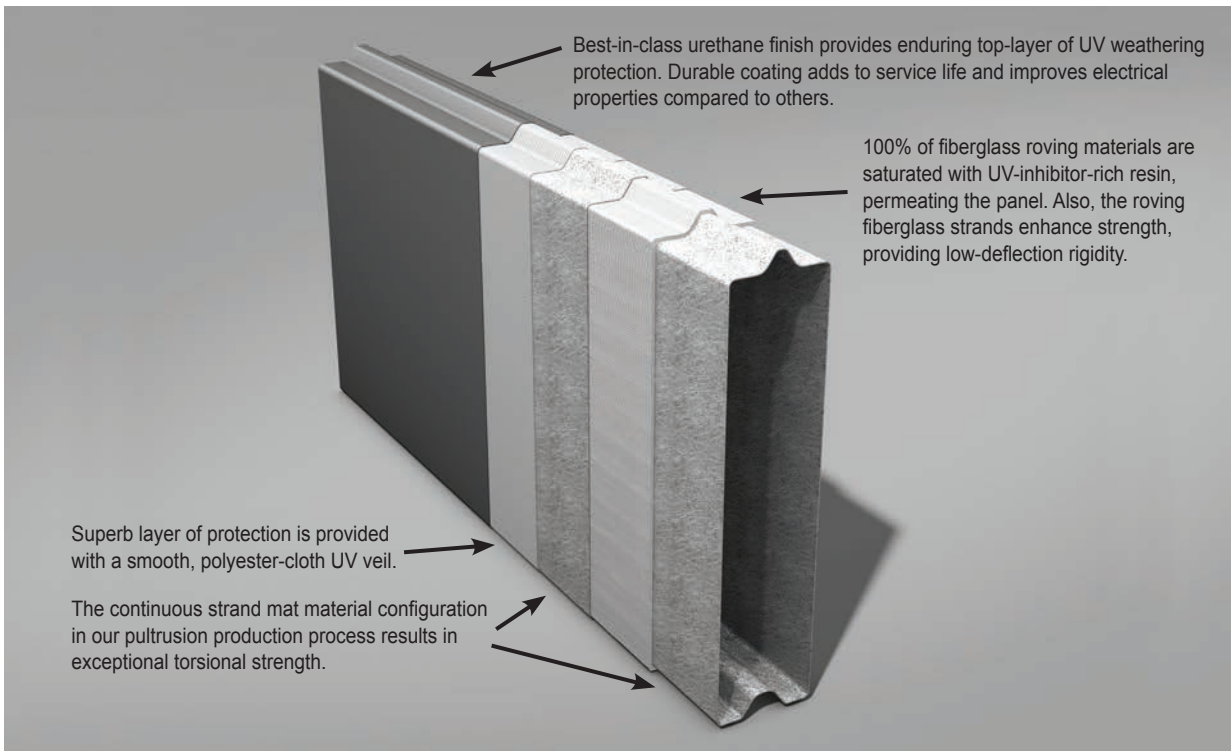

AcoustaShield™ Sound Barrier Construction Benefits



AcoustaShield sound barrier systems can be designed with below-grade, non-corroding, earth-retaining composite spans.

- Can be easily modified and cut in the field for on-site changes/ adjustments
- Spans up to 24-feet are available between either steel, concrete, or fiberglass posts.
- Remarkable durability to maintain attractive appearance during installation and for years to come.
- Lightweight, easily installed with minimal equipment and crew
- Easier and faster to install than concrete, wood, masonry, steel or aluminum
- Non-conductive properties add a measure of safety, security.

AcoustaShield™ is simple, fast and inexpensive to install.

Using a professional installation crew, the work may be completed in a fraction of the time required by masonry, concrete or other fence materials. Composite structures are easy to custom cut in the field to address uneven and steep terrain issues.

The composite planks and posts which comprise the AcoustaShield fencing systems are lightweight and can easily be hand-carried by installation professionals.



AcoustaShield 6-inch high horizontal panels.

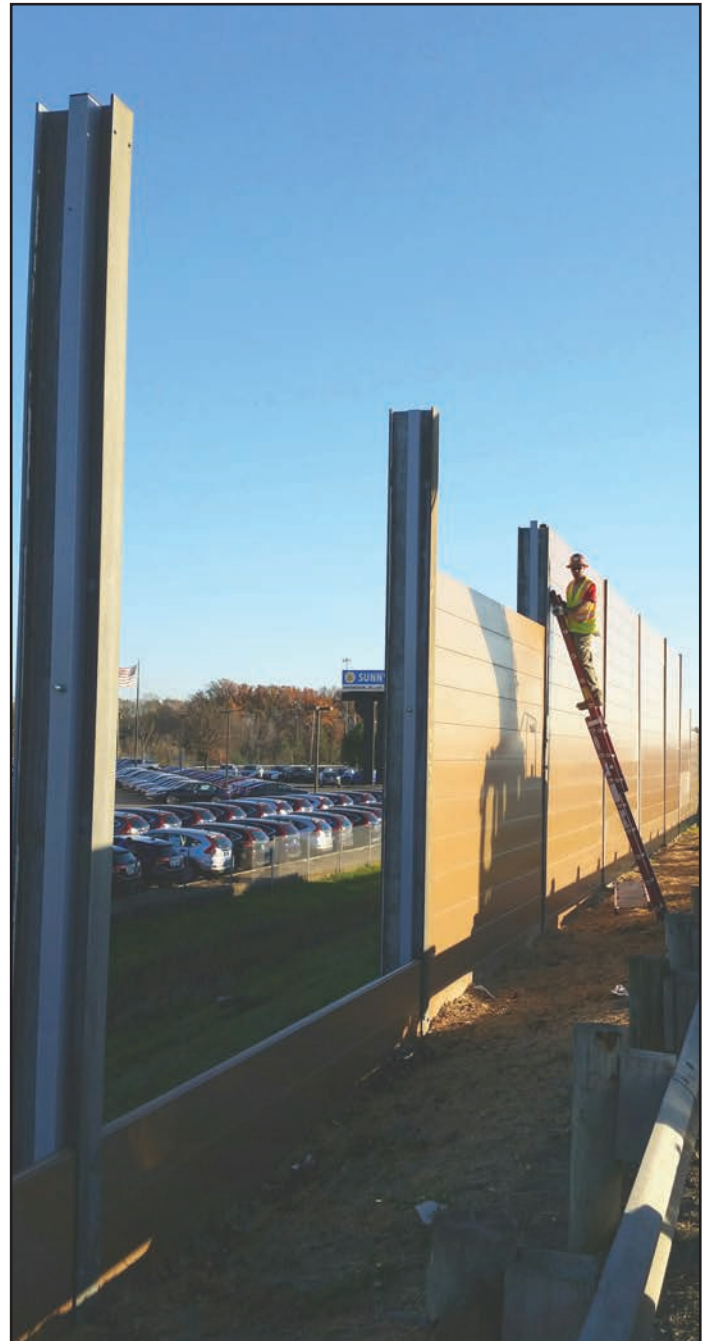

AcoustaShield 12-inch high horizontal panels.

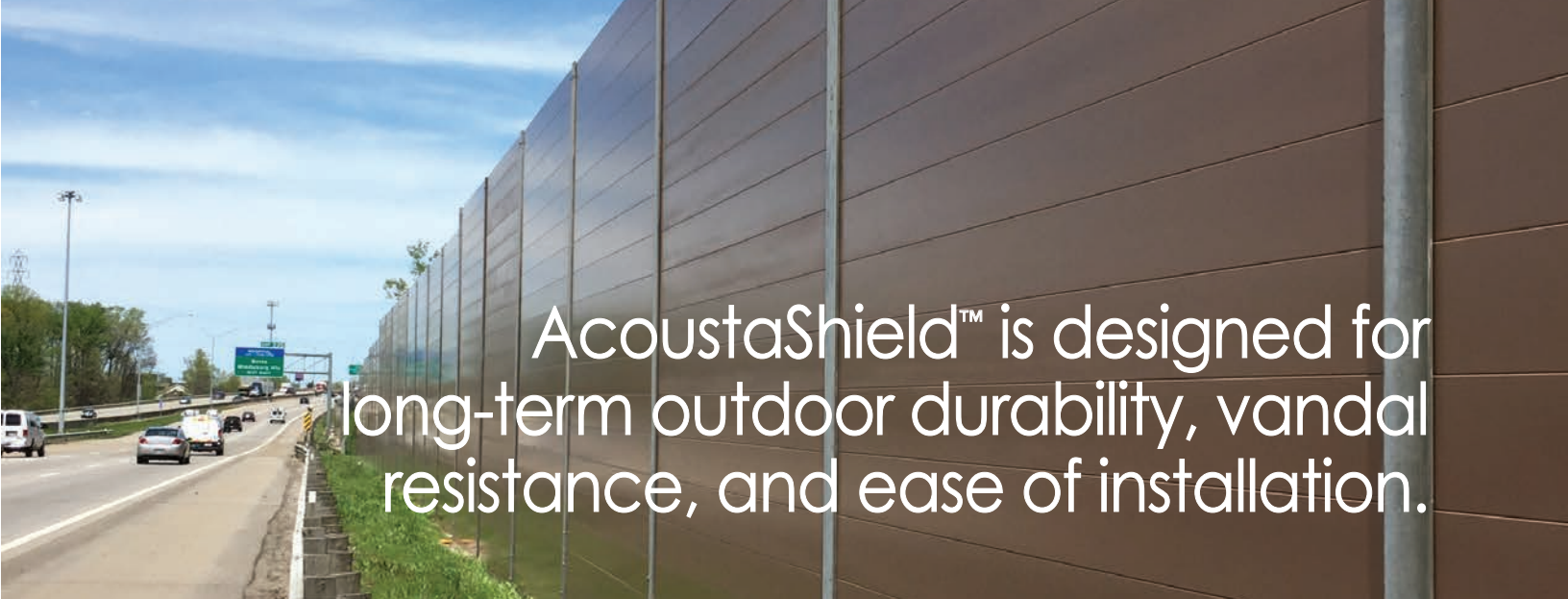

AcoustaShield™ is designed for long-term outdoor durability, vandal resistance, and ease of installation.

AcoustaShield Sound Barrier LONG-TERM BENEFITS

- Engineered fiberglass composite construction is built to last up to 50 years
- Durable construction is rust-proof and corrosion-resistant
- Extremely low maintenance over the product life saves time, money
- In the event of vehicle impact or other damage, the panels are easy to repair or replace
- Graffiti-resistant properties maintain the product's good looks
- A variety of Federal Standard 595B-compliant colors, and RAL colors available upon request
- Non-conductive properties add a measure of safety
- Excellent freeze/thaw resistance, moisture resistance, and fire resistance



12-inch high absorptive panels with traffic-facing view (left) and neighborhood-facing view (right).

Attractive and crafted for long-term durability, the AcoustaShield Sound Barrier System is designed for use in all climate types.

ACOUSTICAL RATING FACTOR

Key Terms

STC: Sound Transmission Class (Coefficient) is the measure of how well a material blocks sound.

NRC: Noise Reduction Coefficient is the measure of how sound is absorbed by an object.

AcoustaShield sound barrier systems are available in 12-inch high or 6-inch high horizontal composite panels.

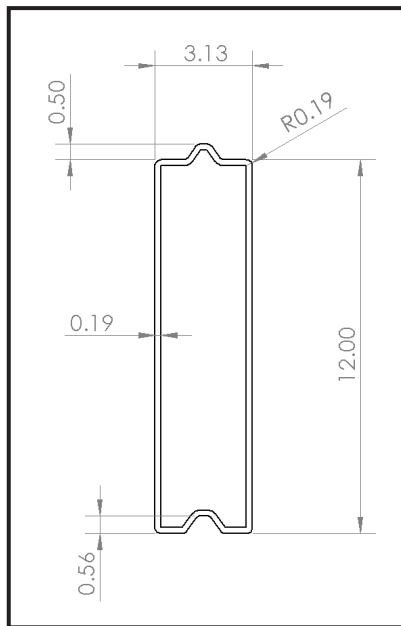

12-inch reflective panel

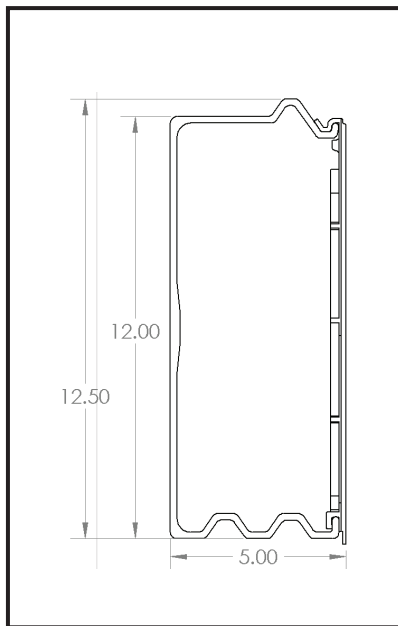

12-inch absorptive panel

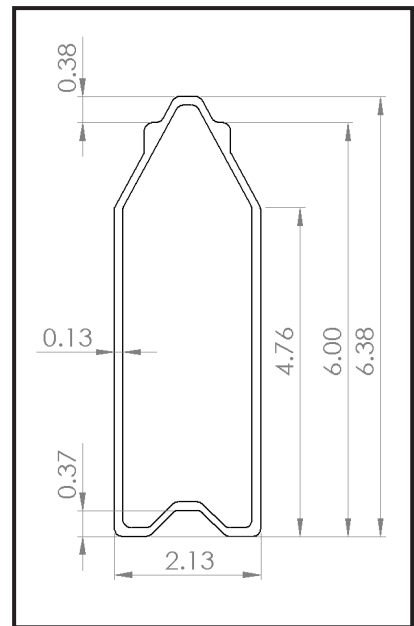

6-inch reflective panel

ACOUSTASHIELD RATING FACTORS			
TYPE OF SYSTEM	12" REFLECTIVE	12" ABSORPTIVE	6" REFLECTIVE
AVERAGE STC RATING	35	36	28
NRC VALUE	0.15	1.05	0.15

A 6-inch high panel, which is filled with recycled tire rubber, is available upon request.

See How AcoustaShield Compares To Other Fencing Materials

See the material comparison tables below for design and installation factors to consider when comparing AcoustaShield sound barrier fencing systems to concrete, wood, and metal fencing materials.

MATERIAL COMPARISON - DESIGN FACTORS				
	ACOUSTASHIELD	CONCRETE	WOOD	METAL
TYPE OF SYSTEM	POST & PANEL	POURED/POST & PANEL	POST & PANEL	POST & PANEL
MOISTURE RESISTANCE	EXCELLENT	GOOD	POOR	POOR
FREEZE-THAW RESISTANCE	EXCELLENT	FAIR	POOR	POOR
TYPICAL SERVICE LIFE	50+ YEARS	50 YEARS*	25 YEARS	25 YEARS
EASE OF INSTALLATION	EXCELLENT	FAIR	FAIR	FAIR
FIRE RESISTANCE	EXCELLENT	EXCELLENT	POOR	EXCELLENT
GRAFFITI RESISTANCE	EXCELLENT	POOR	POOR	POOR
WEIGHT PER SQUARE FOOT	5-8 lbs.	100-125 lbs.	30-45 lbs.	5-7 lbs.

*Compared to AcoustaShield sound barrier, concrete, wood, and metal products may have a much shorter service life in areas where de-icing road treatments are used for snow and ice.

MATERIAL COMPARISON - INSTALLATION FACTORS				
	ACOUSTASHIELD	CONCRETE	WOOD	METAL
HEAVY EQUIPMENT REQUIRED	NO	YES	NOT ALL	YES
CAN BE USED ON BRIDGES	YES	NO	NO	YES
CHALLENGING TERRAIN	YES	NO	NO	NO
ONSITE CHANGES/ADJUSTMENTS	YES	NO	YES	NO

AcoustaShield™

SOUND BARRIER SYSTEM

Precision crafted for outstanding performance

A time-proven performer, Carsonite is a leader in developing composite sound barriers, delineators, and markers for the transportation industry.

- **Environmentally friendly** - Winner of Federal Highway Administration's Environmental Award of Excellence for Innovation.
- **Ease of installation** - Our lightweight composite components save time, manpower, equipment, and money during installation.
- **Custom-fit adjustments in the field** - AcoustaShield can be easily modified and cut during installation for quick on-site changes/adjustments.
- **Built to last** - Fiberglass composite components will never rust and perform exceptionally well in high-traffic environments found in busy metropolitan areas, humidity and salt-air environments along coastlines, and in cold, snowy environments where deicing agents are frequently used.
- **US designed and built** - AcoustaShield is engineered and produced in Newberry, SC. The fence panels are manufactured from fiberglass reinforced thermoset material using a heated pultrusion process that delivers consistent quality and performance.
- **Safety** - Non-conductive design is ideal for installation in high-traffic and heavily populated areas.
- **Proven performance** - With thousands of miles of sound barrier installed, our composite fencing systems have been used for years along busy highways, railways, and other transportation corridors.



To learn more about the features and benefits of AcoustaShield Sound Barrier Systems, contact Carsonite.

19845 US Highway 76 | Newberry, SC 29108 USA | Phone 800.648.7916 | Fax 803.276.8940

www.carsonite.com

