

## Expand SAP® HANA® Server Memory at a Better TCO



Ultrastar DC ME200 Memory Extension Drive, NVMe™ 2.5-inch U.2 and AIC HH-HL form factors

### Total Cost of Ownership (TCO) Highlights

- Significantly reduces cost per GB of memory
- Improve memory density by overcoming the limitations of DIMM slots per server
- Enables server consolidation of multiple tenants
- Reduce overall data center footprint and power consumption

### Product Features

- Up to 24TiB software-defined memory per 2U server (U.2) and 96TiB in 4U servers
- Works transparently with existing Linux® distributions and SAP HANA application stack
- Available in increments of 1,2 or 4 TiBs

### Ultrastar® DC ME200 Memory Extension Drive Enables Plug-in Expansion for SAP HANA Server Memory

SAP HANA in-memory databases require the entire data set resides in memory. Customers using SAP HANA as one of their key IT components, see a growing demand and benefits for the ability to support a larger data set of multiple and even dozens of TBs in size, as it provides better business insight, enables consolidation of previously separate systems, and is an enabler for building new solutions.

### The Problems with Scaling System Memory

The requirement to have a system capable of holding multiple TiBs of system memory (and even dozens of TiBs) poses a problem, as modern server architectures are limited to 12 DIMMs per socket, and at the same time the DIMM capacity is also limited: the \$/GB sweet spot is the 32GiB DIMMs; 64GiB DIMMs come with a premium, and 128GiB DIMMs are more than double the cost per GB.

This results in a de facto limitation of 1.5TiB per dual socket server (3TiB per quad-socket, and 6TiB for an 8-socket server), where there is a significant overhead cost associated with adding more memory, since more sockets and/or proprietary servers are required

### The Drawbacks of Scaling Down

The high cost of such large memory servers may limit the ability to store all needed information for real-time access, and as a result leads to compromise, off load historical data, which falls short of reaching the full business potential of deploying SAP HANA.

In addition, for each production SAP landscape, SAP customers have a variety of non-production landscapes (i.e., QA, DEV, UAT, Production Support, Projects, sandboxes, etc.), where typically a compromise is made to scale down the amount of data for those systems (instead of having them as a similar snapshot to production), due to the cost of the underlying system hardware.

This may limit the ability to identify potential issues way before they reach the production system, and as a result increase the risk of identifying issues only in production, as well as higher support cost.

### Ultrastar DC ME200 Memory Extension Drive

Ultrastar memory drive combines one or more custom NVMe drives, tuned for performance, with a software layer that expands system DRAM onto them. Unmodified Linux operating systems can then use up to eight times<sup>1</sup> the capacity of the DRAM installed in a server with near-DRAM performance.

SAP HANA can utilize this extra system RAM without any changes. For example, a 1U server with 768 GiB installed can make use of up to 6 TiB of Ultrastar memory.

This cost-effective method of scaling system memory with DRAM-like performance makes it possible and affordable to run SAP HANA with as much memory as needed and benefit from all business and technical aspects of SAP HANA for production as well as non-production landscapes.

Implementing SAP HANA is a journey, and SAP HANA stakeholders can plan accordingly to accommodate future data growth patterns with Ultrastar memory drives.

<sup>1</sup> Suggested expansion of 8x DRAM based on internal performance testing across a variety of industry standard benchmarks.

Transform storage capacity...

...into system memory capacity

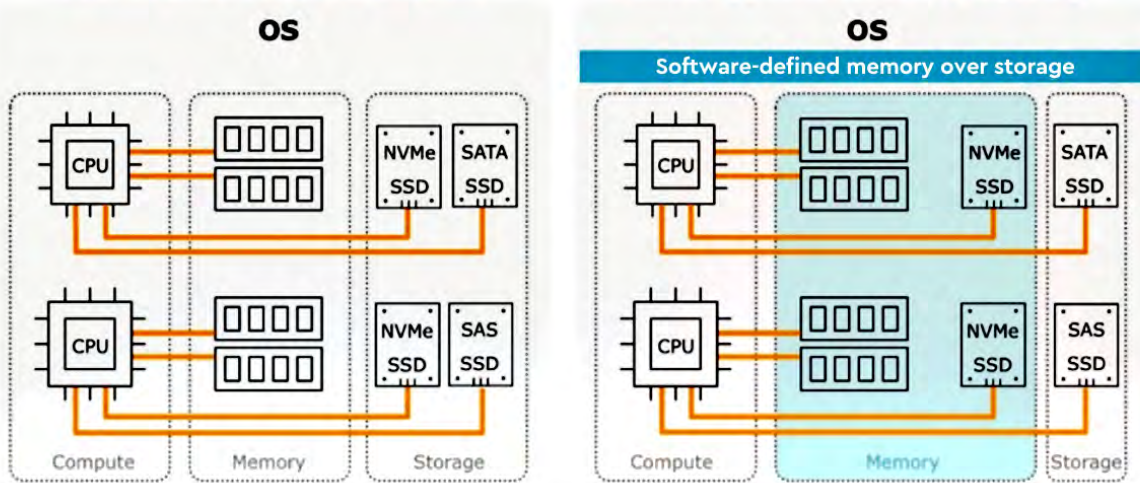
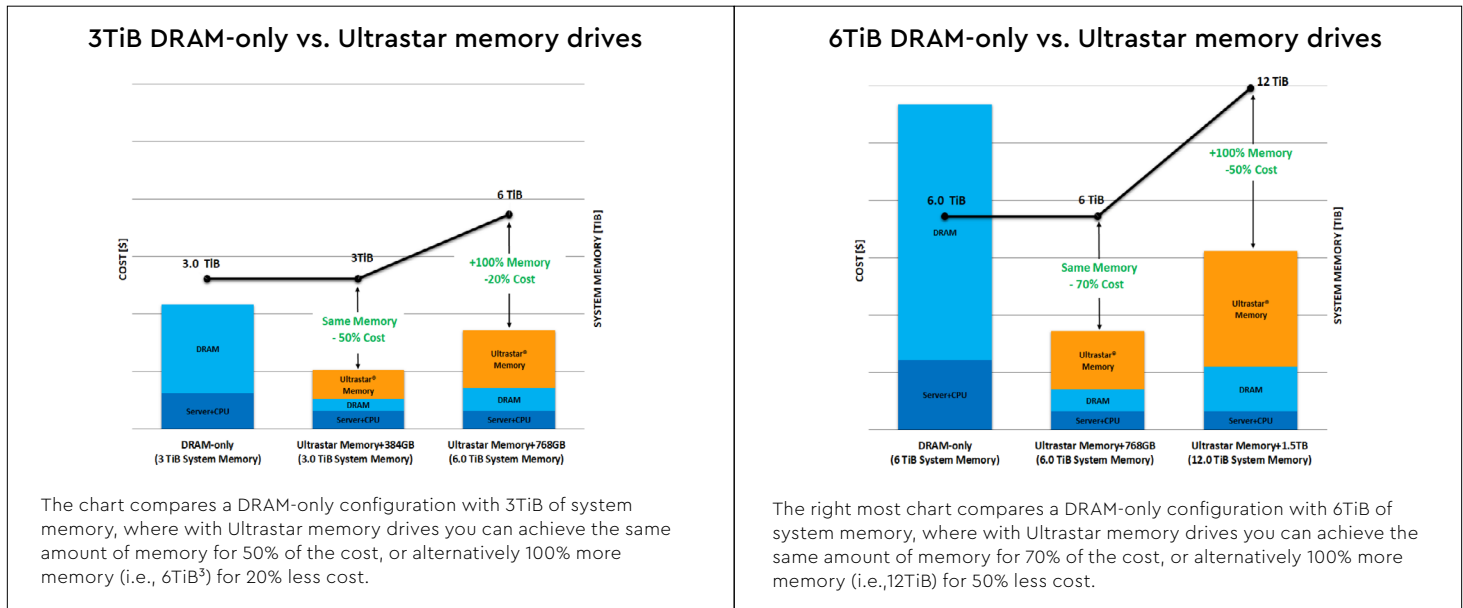

Figure – The left diagram depicts the traditional compute-memory-storage architecture. The right diagram depicts how database instance configurations can take advantage of Ultrastar® memory drives to augment server DRAM to create a virtualized memory pool to enable greater memory expansion.

Cost Savings

The following charts compare the cost and available system memory of several DRAM-only configurations to more cost-effective configurations with equal or higher amount of available system memory using Ultrastar memory drives.<sup>2</sup>



The ability to have much larger amount of memory in a cost-effective way, while maintaining DRAM-like performance, enables you to truly benefit from all HANA capabilities with no limitations, in addition to having production-like systems for your non-production landscape, without the need to compromise.

<sup>2</sup> Based on DRAM spot pricing (Feb. 2019)

<sup>3</sup> Memory capacity is indicated by GiB and TiB and based on binary values such that one gibibyte (GiB) is equal to 2<sup>30</sup> bytes and one tebibyte (TiB) is equal to 1024 GiB (2<sup>40</sup>) bytes. Accessible capacity can vary from stated capacity due to software, formatting, and other factors.

Western Digital

5601 Great Oaks Parkway  
 San Jose, CA 95119, USA  
 US (Toll-Free): 800.801.4618  
 International: 408.717.6000

©2019 Western Digital Corporation or its affiliates. All rights reserved. Western Digital, the Western Digital logo, and Ultrastar are registered trademarks or trademarks of Western Digital Corporation or its affiliates in the US and/or other countries. Linux® is the registered trademark of Linus Torvalds in the U.S. and other countries. SAP and HANA are the trademarks or registered trademarks of SAP SE in Germany and in several other countries.

All other marks are the property of their respective owners. References to any Western Digital product does not mean it will be available in all countries.

www.westerndigital.com