



# **Campus Sign Program**

## Signage Guidelines

Prepared for  
**University of California, Berkeley**

By  
**Skidmore, Owings & Merrill**

26 January 1995

# Acknowledgements

## **Skidmore, Owings & Merrill**

Lonny Israel, Associate  
Project Designer

John Kriken, Partner  
Planning Consultant

## **EDAW**

Phillip Enquist, Senior Associate  
Design Consultant

Richard Bender, Professor  
Planning Consultant

This project could not have been completed without the participation of the following individuals.

## **Sponsors**

Leroy E. Bean, FAIA  
Associate Vice Chancellor  
Business, Planning, Design and  
Construction

Daniel Boggan, Jr., Vice Chancellor  
Business and Administrative Services

## **Current Participants in the Signage Working Group**

Royce Brister, Senior Superintendent-  
Structural Trades Physical Plant-  
Campus Services

Judy Chess, Senior Planner  
Physical and Environmental Planning  
Planning, Design and Construction

Michael Dobbins, Director  
Physical and Environmental Planning  
Planning, Design and Construction

David Duncan, Senior Planner  
Physical and Environmental Planning  
Planning, Design and Construction

John Hickey, Design Director  
Berkeley Publications

Michael Huff, Assistant Athletic Director-  
Facilities Intercollegiate Athletics and  
Recreational Sports

Robert Jacobs, Assistant Director-  
Residence Hall Facilities  
Housing and Dining Services

William McDonald, Director  
Berkeley Publications

Robert Odermatt, FAIA, Member-  
Campus Design Review Committee  
The Odermatt Group

Nadesan Permaul, Director-  
Transportation and Emergency Planning  
Parking and Transportation

Corliss Watkins, Director  
Visitor Information Center

Ortha Zebroski,  
Campus Landscape Architect  
Design and Project Management  
Planning, Design and Construction

## **Contributors**

Darrell Carter, Assistant Dean  
School of Optometry

Steve Finacom, Administrative Analyst  
Physical and Environmental Planning  
Planning, Design and Construction

Richard Harwood,  
Superintendent of Physical Plant  
Intercollegiate Athletics and  
Recreational Sports

Mary Ann Hiserman,  
Senior Architectural Associate  
Design and Project Management  
Planning, Design and Construction

Thomas Koster, Director  
Space Management and  
Capital Programs

Sharon McConnell,  
Assistant Risk Manager  
Risk Management

## **Other Participants:**

Sharon Bonney, Director  
Transportation Services

Michael Chartock,  
Acting Head of Planning/Development  
Lawrence Berkeley Laboratory

Robert Cole, Director  
Cal Performances

Elizabeth Eubanks, Manager  
Parking and Transit Operations

Christopher McKee, Director  
Space Science Institute

George Rogers, Director  
Botanical Gardens

William Thurston, Director  
Mathematical Sciences Research  
Institute

Gregory Watty, Assistant Director  
Lawrence Hall of Science

# Introduction

The University of California, Berkeley has requested an exterior campus sign program be developed which will organize the multitude of informational, directional and regulatory signs on campus.

Skidmore, Owings & Merrill has proposed a sign program that is made up of diverse elements allowing variation of expression. The system is based on a clear hierarchy developed by a simple underlying principle that the Campus is the equivalent of a city of over 30,000 students, 70 city blocks in size, with over 200 buildings of various ages and styles. The system must be capable of being implemented over a number of years and, therefore, be adaptable to change.

This wayfinding system needs to be universally understandable for first-time visitors, students, faculty and alumni.

The 3 categories of signage are as follows:

## **Informational**

This type of signage is the first major introduction to the campus. It includes identification information such as street and path names, building identification and campus maps. This category could also include helpful information such as safety/protection tips, listing of facility hours, phone numbers and current events.

## **Directional**

Signage that directs you from surrounding areas to the campus, parking and campus shuttle bus. Also included is directional signage within the campus.

## **Regulatory**

Public and permit parking information is covered in this category, as well as accessible signage and regulatory signage.

Look to the following sections when you are ready to implement one of the above sign categories—

## **Guidelines**

Outlines the components that make up the basic sign types. Covers recommended layouts, typefaces and colors.

## **Sign Types**

Illustrates the guidelines applied to the 3 categories of signage; Informational, Directional and Regulatory. Covers dimensions, proportions and mounting specifications.

## **Case Study**

Implementation of the guidelines to signage and flyers for U.C. Berkeley Parking and Transportation Department.

# Informational Signage

This type of signage is the first major introduction to the campus. It includes identification information such as street and path names, building identification and campus maps. This category could also include helpful information such as, safety/protection tips, listing of facility hours, phone numbers and current events.

- I-1 West Gatehouse**
- I-2 Bus Shelters**
- I-3 BART Station,  
Welcome to the Campus**
- I-4 Campus Maps**
- I-5 Pathway Names**
- I-6 Building Names**
- I-7 On-Campus Building  
Identification**
- I-8 Primary Off-Campus  
Building Identification**
- I-8a Additional Off-Campus  
Building Identification**
- I-8b Property of the Regents  
Identification**
- I-9 Primary Tenant Name  
Identification**
- I-10 Interpretative**



# Informational Signage



## I-1

---

### Sign Type I-1

A key future component to the U.C. Berkeley Signage Program is a redesigned West Gatehouse. This facility is envisioned as a 24-hour staffed gatehouse which would provide parking and directional information for visitors, service vehicles, deliveries, etc. The gatehouse would provide safety for the operator and convenience for the user. It should be conceived of as part of the "civic" entry sequence for the campus and its design should be appropriate to the historic core of the campus.

---

### Message

University of California, Berkeley West Gate Information.

---

### Location

Between the west circle and the crescent on University Drive.

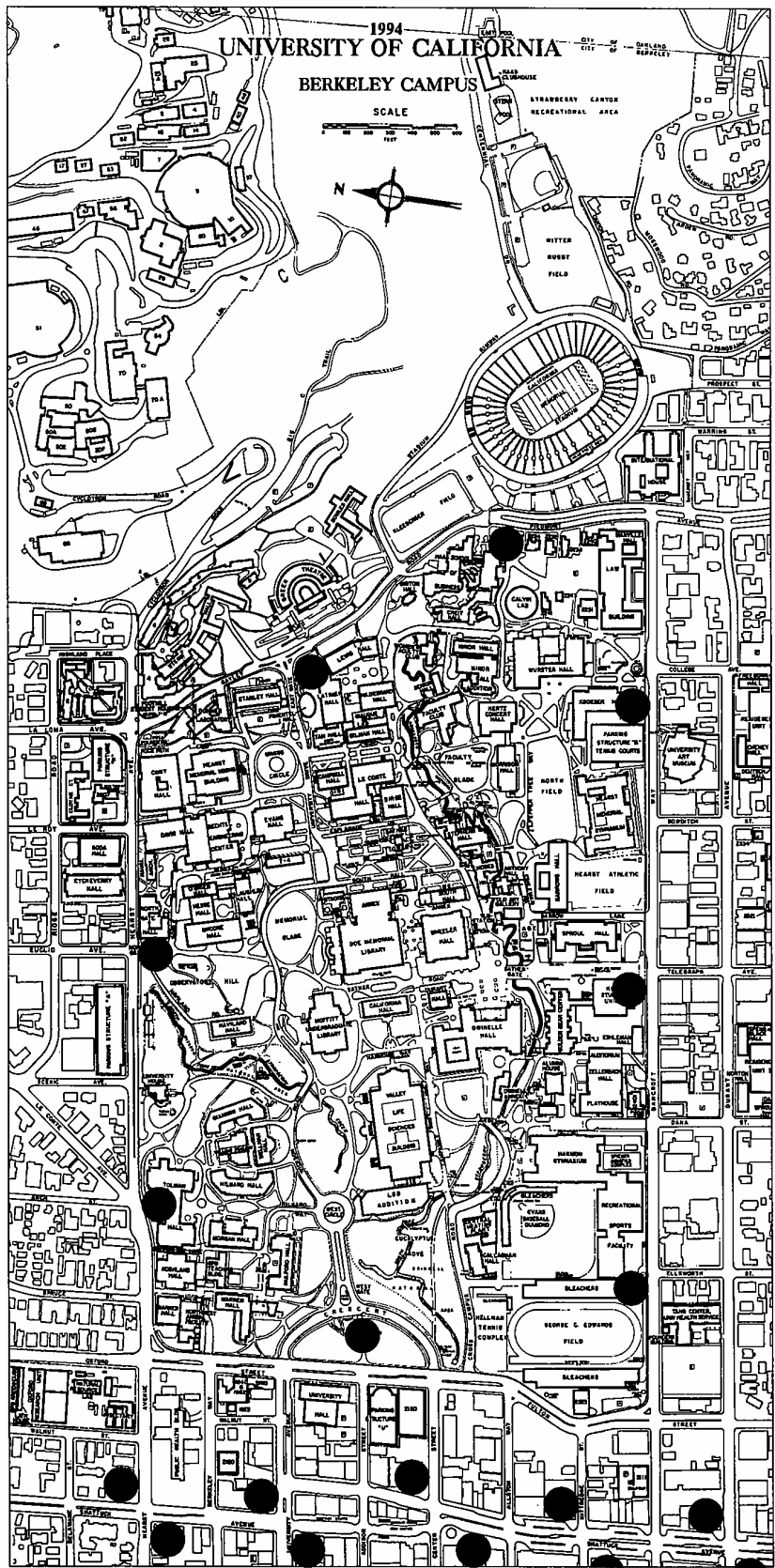

Sign Type I-2 Location Plan

# Informational Signage

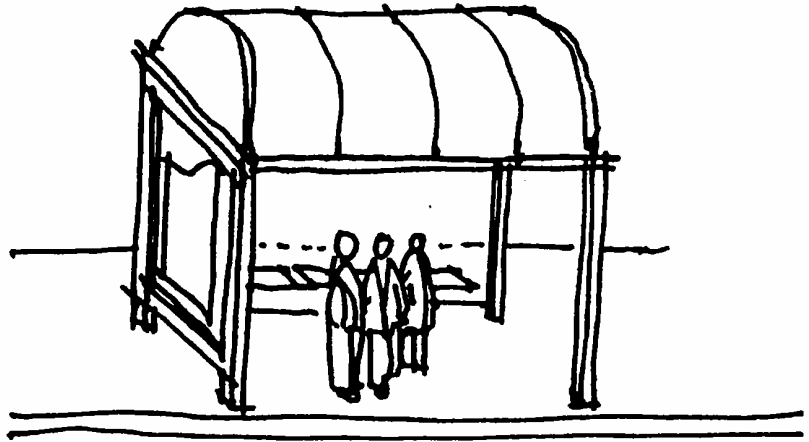

## I-2

---

### **Sign Type I-2**

Bus shelters/stops can be major places of orientation for a visitor or new student. Currently, bus stops convey the most minimal message—the bus schedule. A new generation of bus shelters should be considered which could integrate campus maps, current events, announcements, telephones, etc. This project should be coordinated with the City of Berkeley and AC Transit.

---

### **Message**

A minimal message would be a U.C. Berkeley campus map indicating the "you are here" location in addition to the bus schedules. The campus map should include City of Berkeley blocks surrounding the campus. Street names and building names should be included.

---

### **Location**

Perimeter of campus - major bus line stops that serve the campus.





# Informational Signage

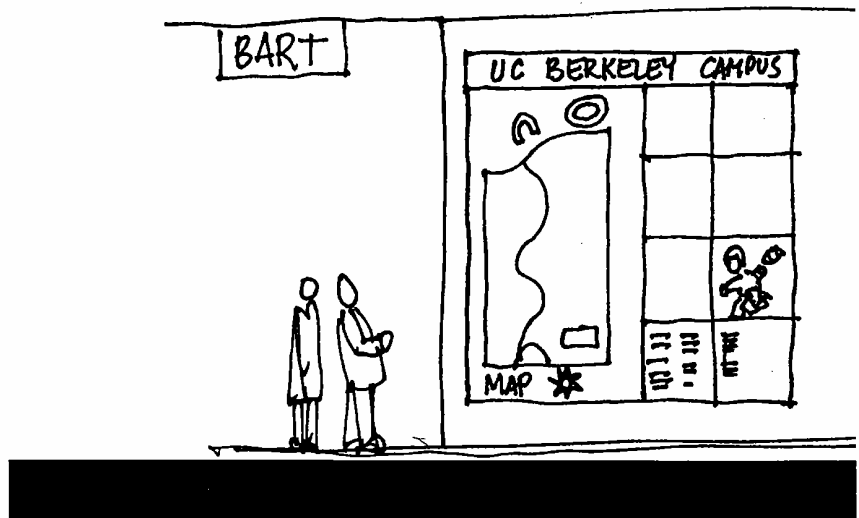

## I-3

---

### Sign Type I-3

At the Berkeley BART station, a "Welcome to U.C. Berkeley" sign graphic should be considered. Currently, no sign exists indicating that this is the U.C. Berkeley station. A suggestion is for the campus, in conjunction with the City, to use a wall within the station, close to the exit, that can display a U.C. Berkeley map and other points of interest related to the campus. A history of the campus, current events in theater and sports, and volunteer programs can all be incorporated into this sign wall.

---

### Message

A minimal message would be a U.C. Berkeley campus map indicating the "you are here" location. The map should include City of Berkeley blocks surrounding the campus. Street names and building names should be included.

---

### Location

Within the U.C. Berkeley BART station or immediately upon exiting.



# Informational Signage

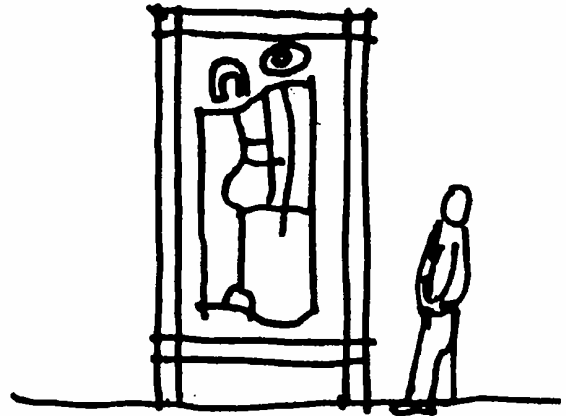

## I-4

---

### Sign Type I-4

The campus map. A very clear, legible map should be developed which communicates building names, pathway names and place names. This map should be incorporated within a frame, protected by glass or plexiglass, allowing the graphic to be updated over time. See Cartography in the Guidelines Section for style recommendations.

---

### Message

The map should include the following:

- all campus building names
- all major pathways
- all major places
- "you are here"
- accessible paths
- shuttle routes and stops
- emergency phones
- emergency phone numbers
- 24-hour West Gate location
- other information (defined by the campus)

---

### Location

The campus map should be located at all entry points to the campus, as well as at key pathway intersections. These maps can be added to the campus over time and should be able to be reproduced at a variety of scales, including a handout size.



# Informational Signage

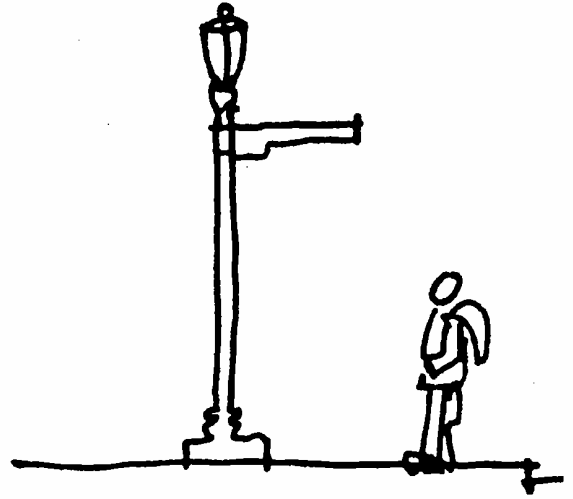

## I-5

---

### Sign Type I-5

Pathways on campus need to be signed in a simple and clear way that enables one to navigate through the campus. Naming and signing pathways are key components to the success of a well-designed campus sign system. Pathway names should be clearly marked on the campus map and then clearly signed on campus. These signs should be paired with existing light fixtures rather than using separate poles.

---

### Message

Path name.

---

### Location

These signs should be located on lamp posts at pathway intersections. Additional signs can be added over time in areas that are particularly complex or confusing. Keeping the number of path signs to a minimum is desirable. This sign system should be paired with the effort to improve lighting on the campus.

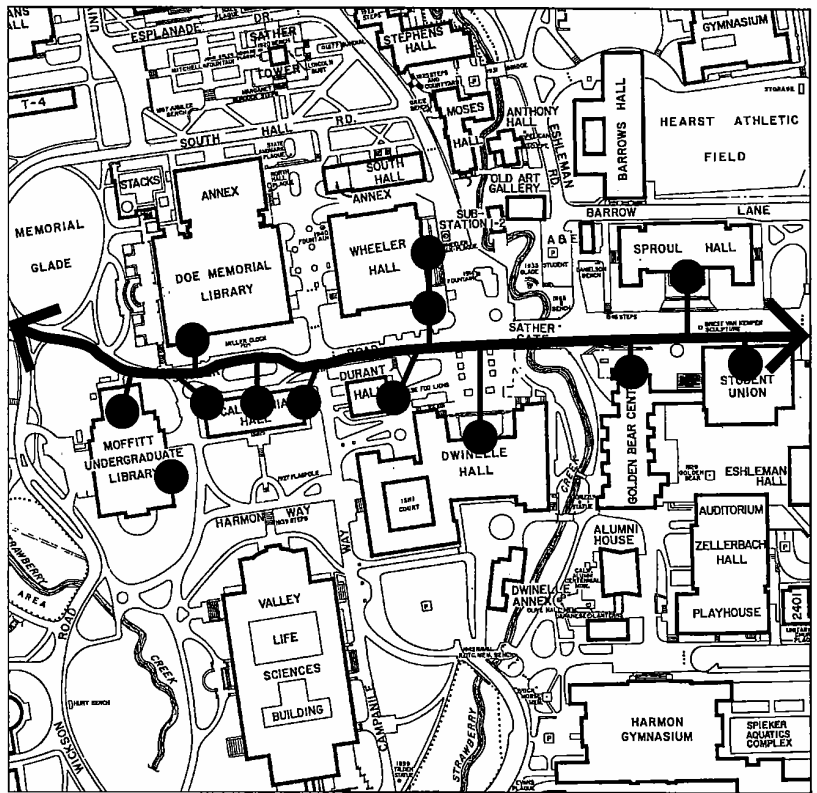

**Sign Type I-6 Location Plan**

# Informational Signage

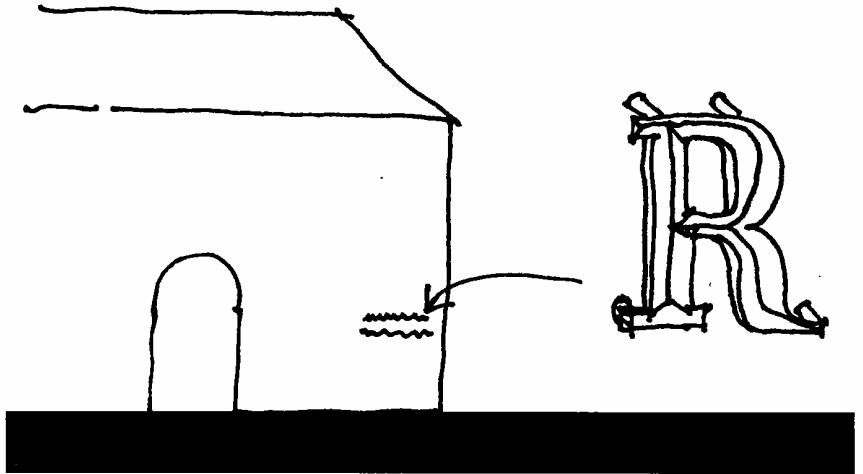

## I-6

---

### Sign Type I-6

On campus, the tradition for signing buildings is using raised metal letters mounted to the building, close to the entrance. Future buildings can apply the same method. Variation in letter style and type of metal is permissible, but should be appropriate to the style of architecture. All signs must meet the requirements set by the Americans with Disabilities Act.

---

### Message

Building name.

---

### Location

Currently, building signs tend to be associated only with the front door. This does not recognize the direction of a pedestrian's approach. For clear recognition, a building should be identified on all sides that face path and roadways.



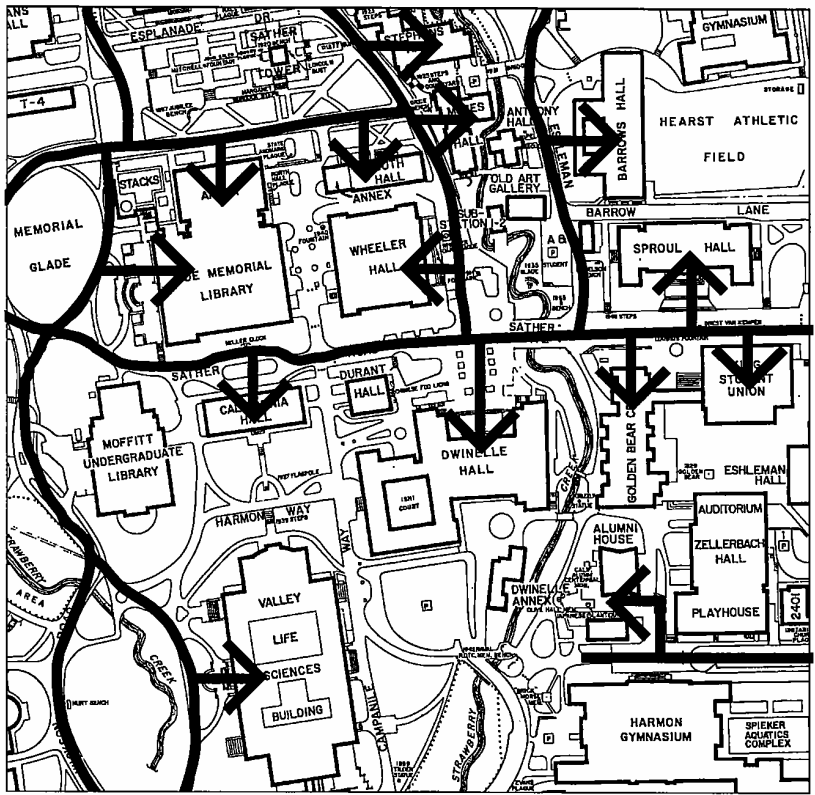

**Sign Type I-7 Location Plan**

# Informational Signage

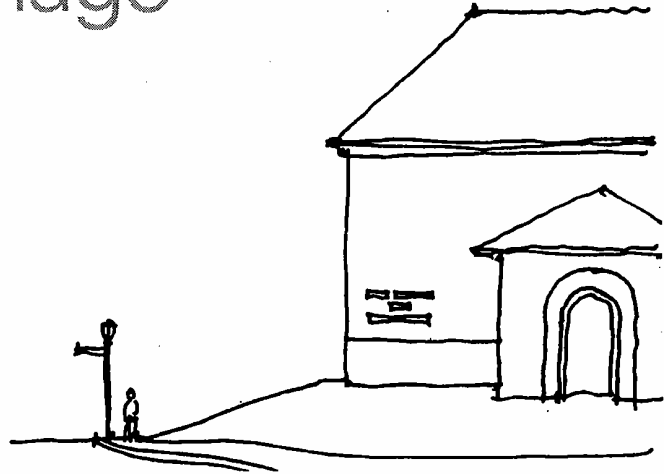

---

## I-7

---

### Sign Type I-7

It is possible for the campus to consider an addressing concept for its buildings which is similar to that of a city. Once pathways are named, each building can address its main entrance to the campus pathway it faces. This may be a complex concept to implement but, in the long run, may improve wayfinding on campus.

---

### Message

Building name, pathway name and numerical address.

---

### Location

On building facade close to building entrance and visible from the main pathway.

# Informational Signage

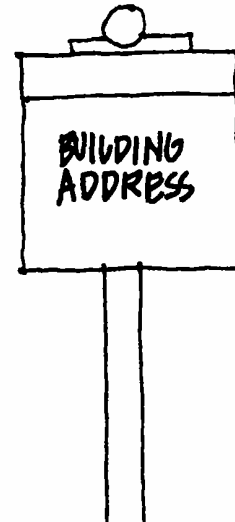

## I-8a

---

### Sign Type I-8a

This sign type is to be used to provide additional identification for off-campus properties which already have some signage. The intent is to clearly identify off-campus properties as part of the University and to clarify building address information.

---

### Message

Building name, tenant name or street address.

---

### Location

On a free-standing pole or wall mounted at or near the main approach to off-campus building entrances.

# Informational Signage



## I-8b

---

### Sign Type I-8b

This sign type is used to identify properties owned by the Regents of the University of California. The intent is to legally identify the property and grant permission to pass.

---

### Message

As provided by the University, "Property of the Regents of the University of California. Permission to pass over is revocable at any time. Peddling and vending of merchandise forbidden."

---

### Location

On free-standing pole or wall mounted at or near entries to the campus or off-campus properties.

# Informational Signage

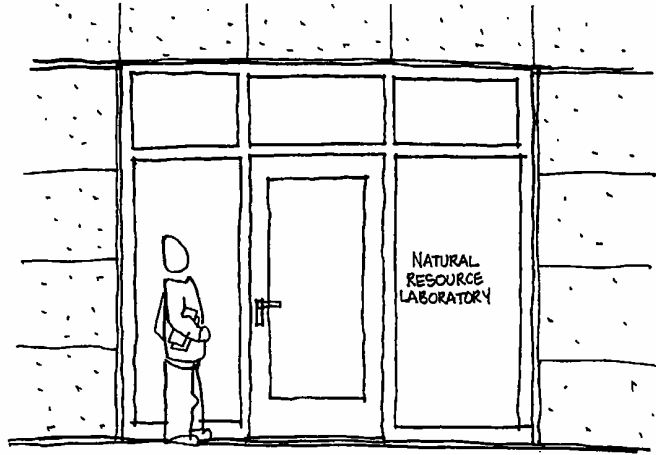

## I-9

---

### Sign Type I-9

Identification of tenants on the exterior of campus buildings should be kept to a minimum. Indicated in the drawing is a primary tenant name located on a glass side light. The name is to be silk-screened, vinyl die-cut, or metal leaf applied to the inside surface of the glass. Building directories should be utilized to provide tenant identification and location within buildings.

---

### Message

Primary tenant's name.

---

### Location

Sign I-9 is to be located at the building entry doors on a glass side light panel as required.

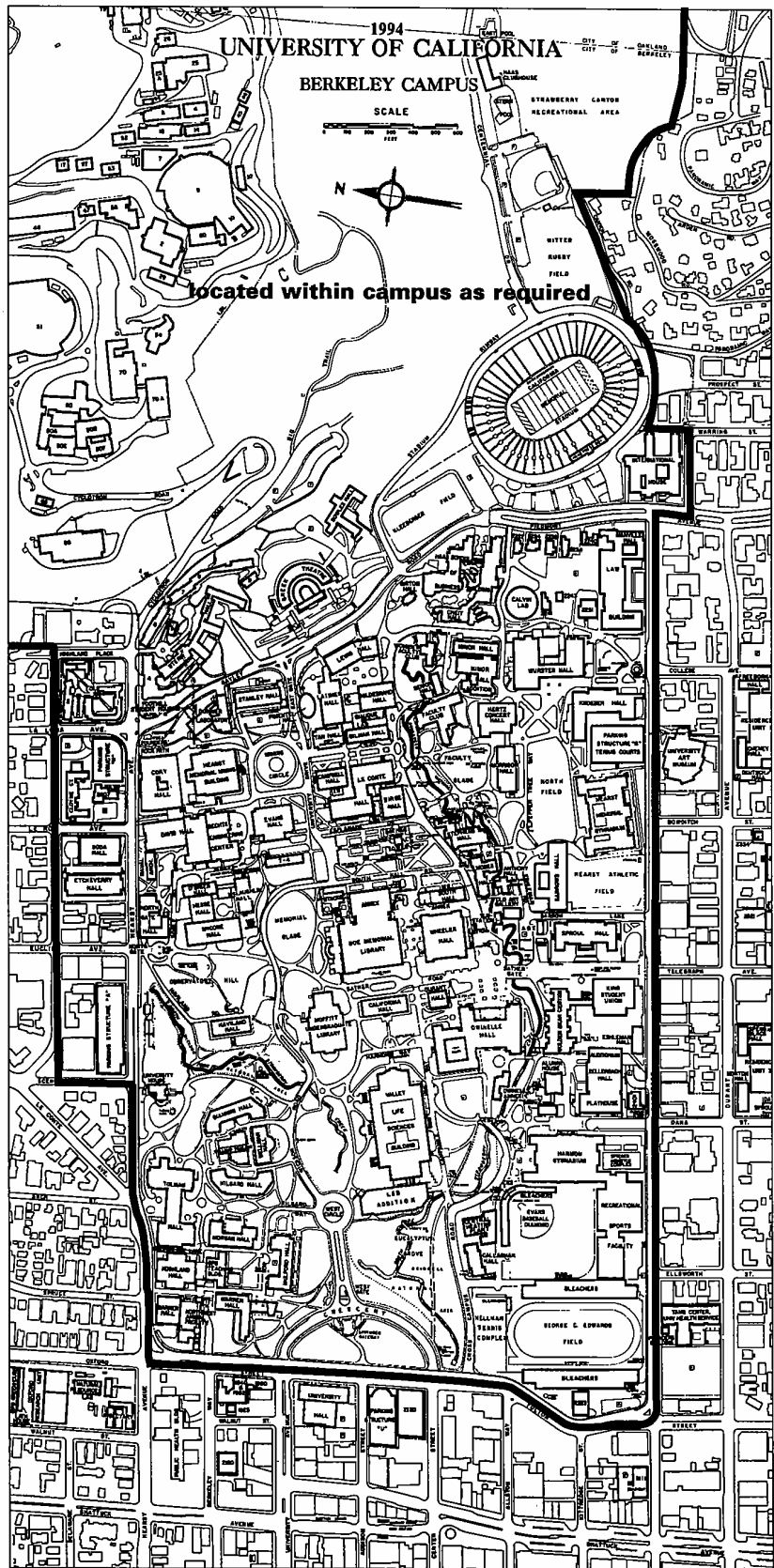

**Sign Type I-10 Location Plan**

# Informational Signage

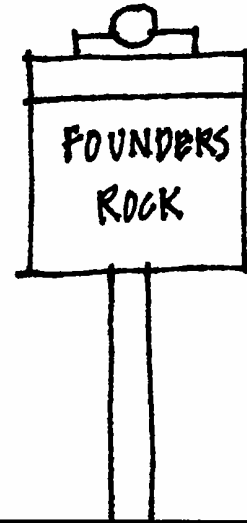

## I-10

---

### **Sign Type I-10**

The campus has many places of interest and historical significance. These places could be identified by interpretive signs that explain the importance of these sites. This type of signage would add to the park-like setting of the campus.

---

### **Message**

Identification of a place or object with a description of its significance.

---

### **Location**

On a free-standing pole at locations within the campus.

# Directional Signage

Signage that directs you from surrounding areas to the campus, parking and campus shuttle bus. Also included is directional signage within the campus.

**D-1 Campus Direction from Freeway Off-Ramps**

**D-2 Parking Location Address**

**D-3 Parking Identification & Shuttle Bus information**

**D-4 Campus Shuttle Stop Signs**

**D-5 Hill Area Destinations**

**D-6 Hill Area Map**

**D-7 Hill Area Directional Signs**



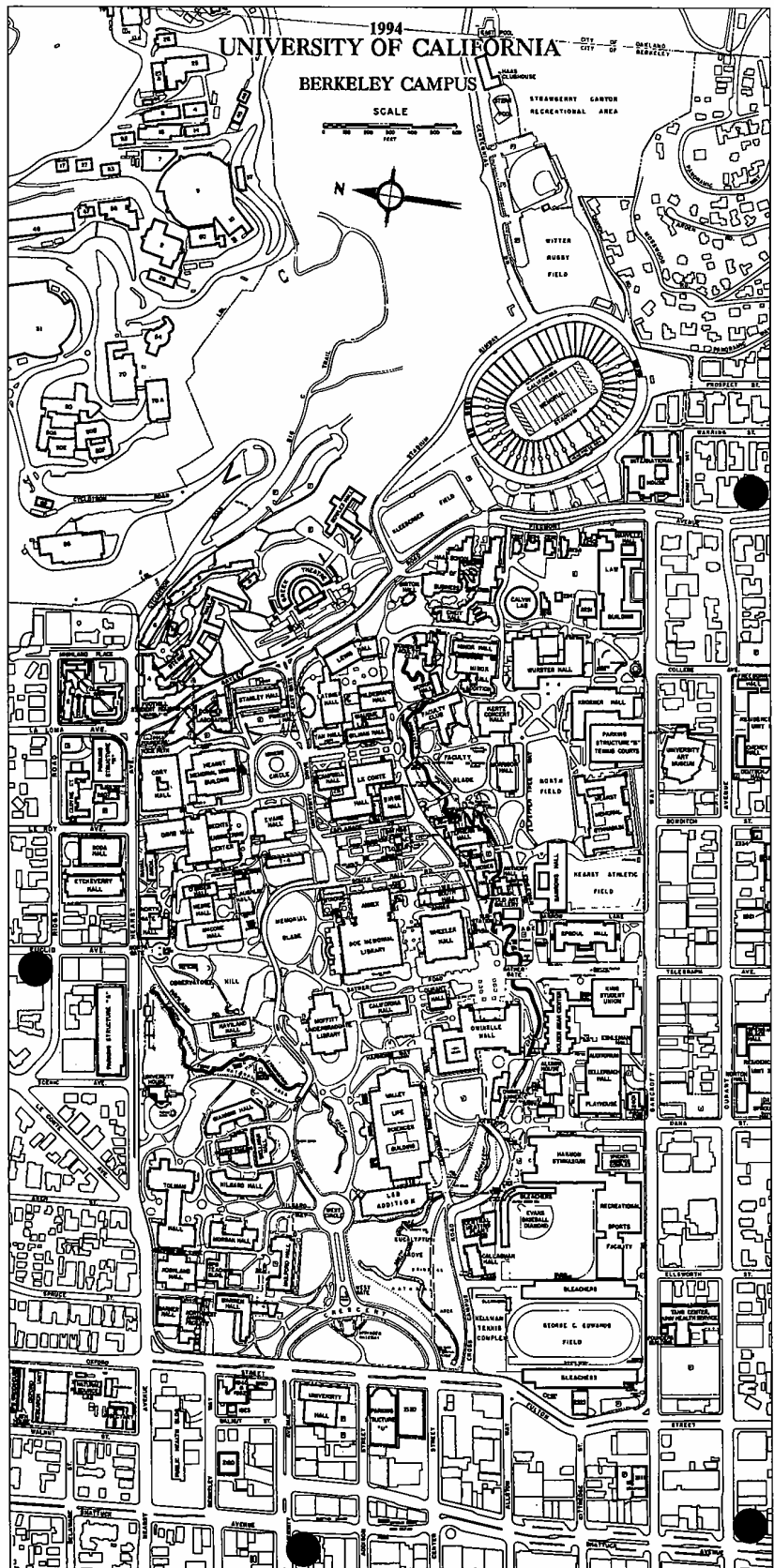

**Sign Type D-1 Location Plan**

This map indicates a few of the signs required. Signs would be located from surrounding freeways to the perimeter of the University.

# Directional Signage

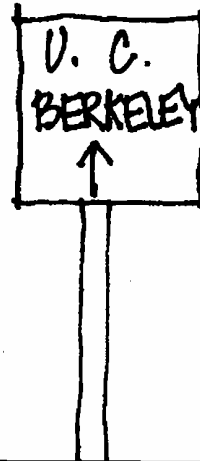

## D-1

---

### Sign Type D-1

This sign type is intended to be located within the City of Berkeley and City of Oakland. The intent is to help guide people from the off-ramps of the surrounding freeways to the campus. The signs can be in the U.C. Berkeley graphic style or can meet each City's sign standards.

---

### Message

University of California, Berkeley, with an arrow pointing toward the campus.

---

### Location

Between I-80 off-ramps (Ashby, University, Gilman) and campus. Between I-24 off-ramps (Claremont, College) and campus. Between Warren freeway and campus. Specific city locations to be determined with the City's planners.

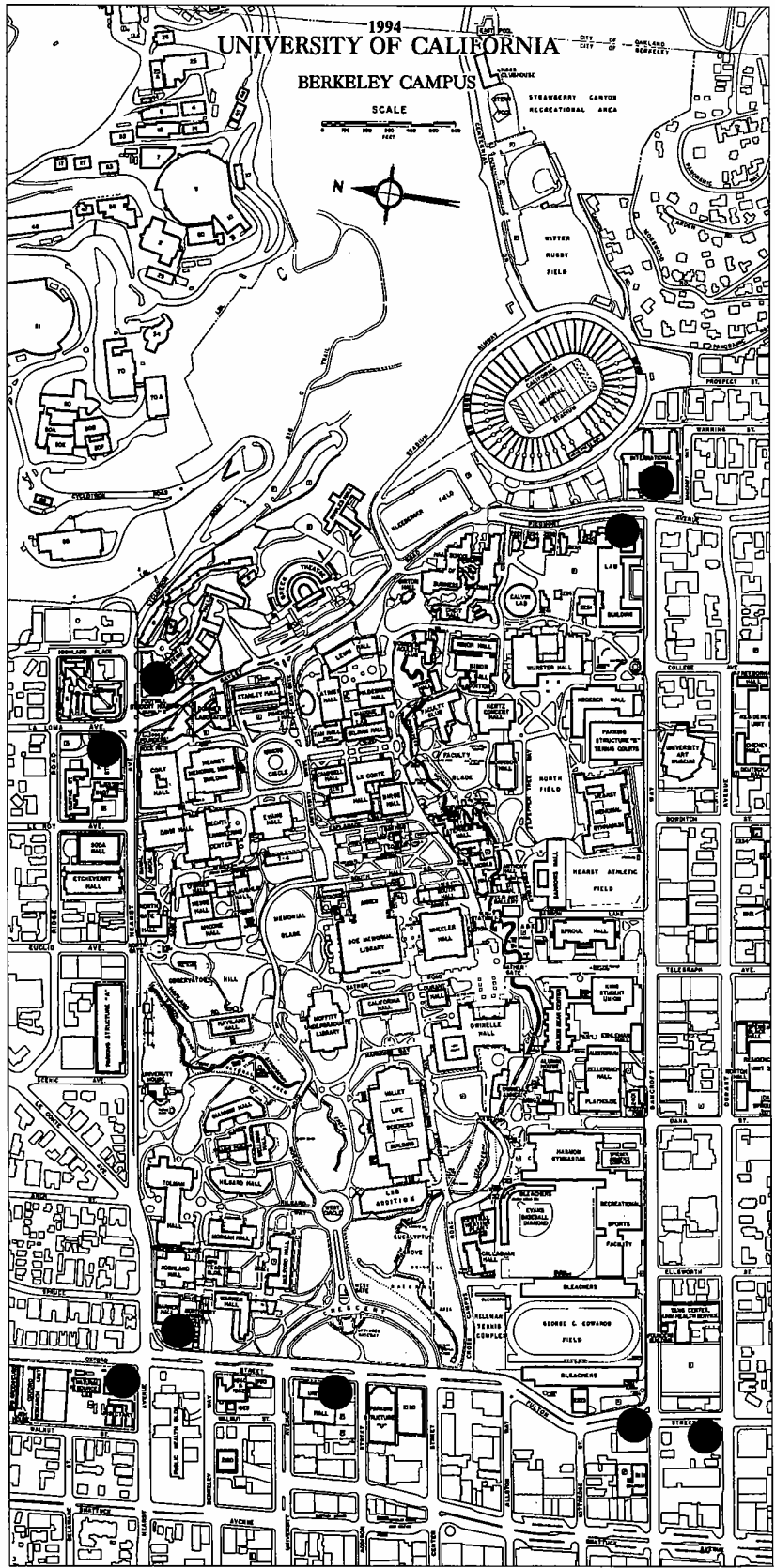

Sign Type D-2 Location Plan

# Directional Signage

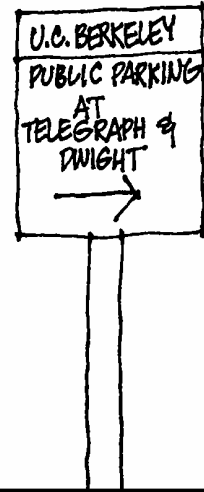

---

## D-2

---

### Sign Type D-2

Once at the campus, this sign can help to direct one to a public parking area or structure. This may be developed in conjunction with the City of Berkeley using City parking facilities as well as those on or near the campus.

---

### Message

University of California, Berkeley, public parking at (specific address).

---

### Location

On major streets close to campus, for example: University, College, Shattuck, Bancroft, Durant, Hearst, and Gayley.

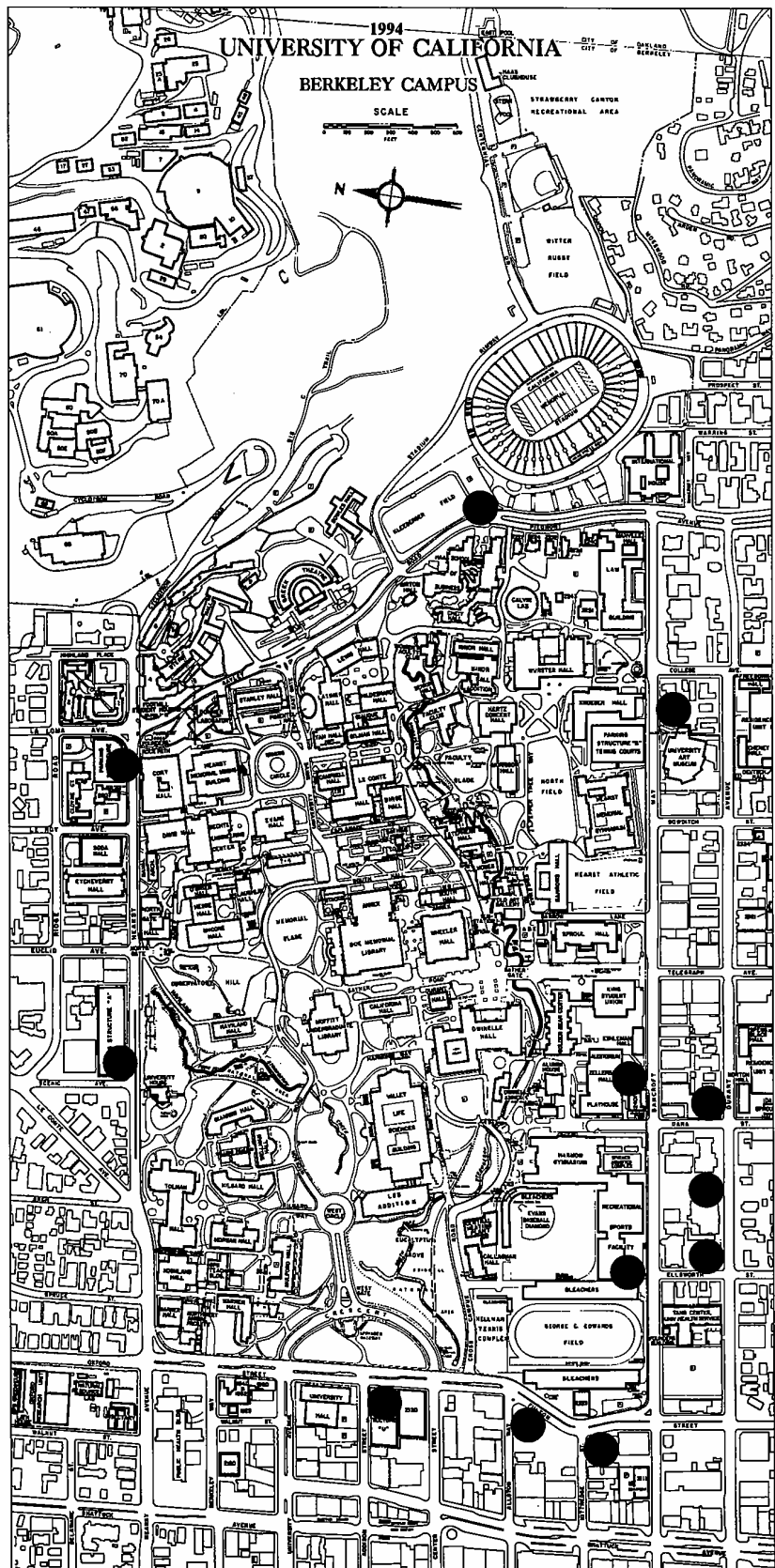

**Sign Type D-3 Location Plan**

This map indicates a few of the signs required.

# Directional Signage

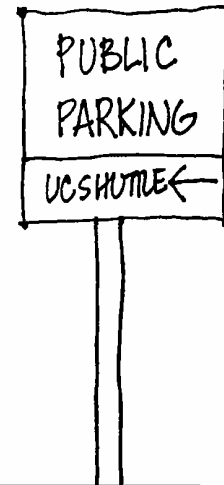

---

## D-3

---

### Sign Type D-3

Public parking areas should be clearly identified. As part of the identifying message, a shuttle bus stop can be identified as well for the benefit of a driver who is leaving his/her car and heading toward the campus.

---

### Message

Public parking - lot or structure identification. Shuttle bus stop information.

---

### Location

At public parking lots/structures.

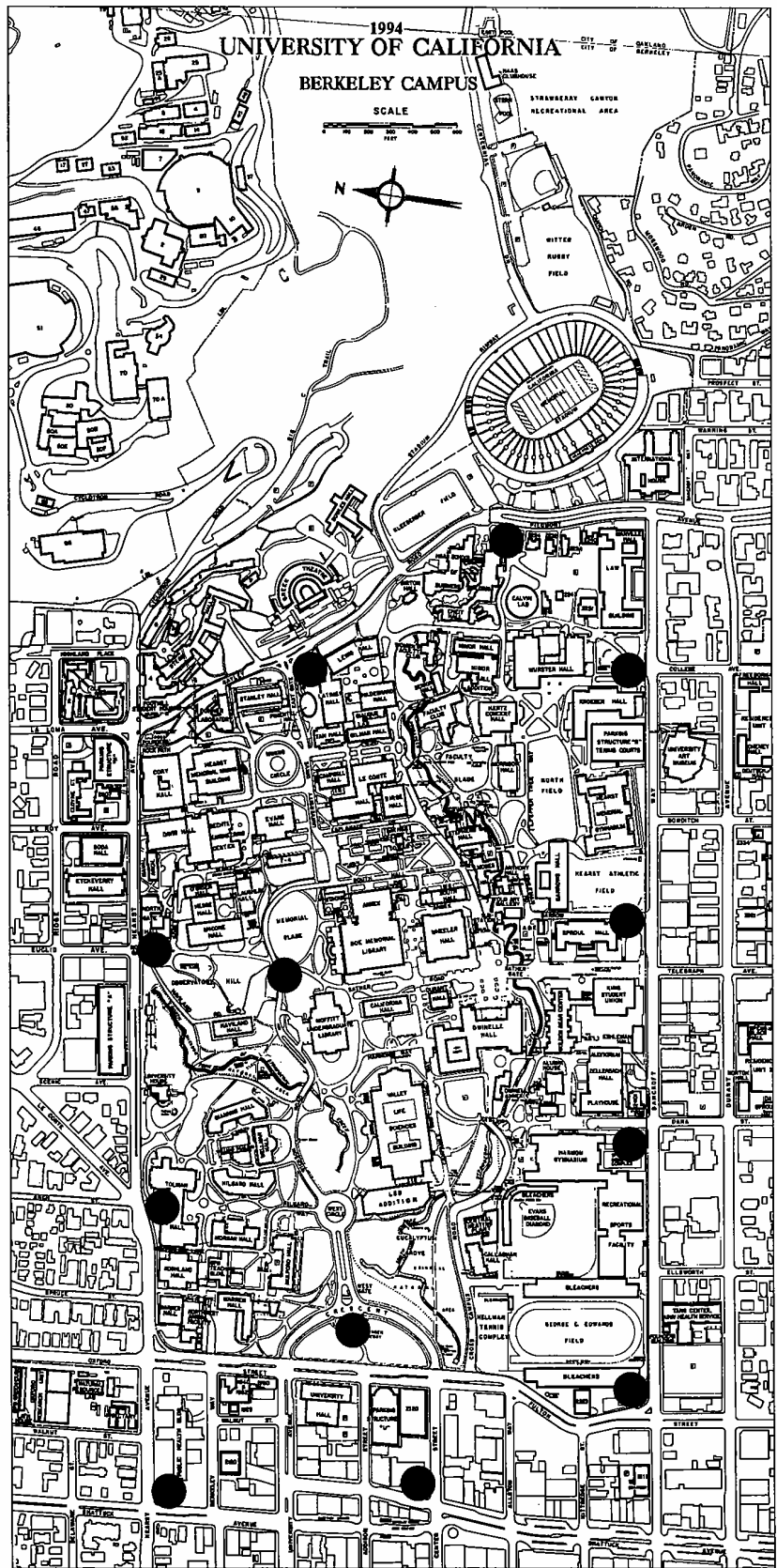

**Sign Type D-4 Location Plan**

# Directional Signage

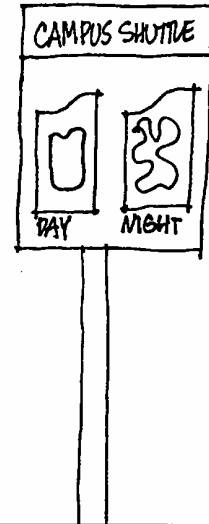

---

## D-4

---

### Sign Type D-4

Campus shuttle stop sign. This sign should convey the current day and night time shuttle routes, stops and frequency. This sign should be clearly visible and easy to identify from a distance.

---

### Message

Campus shuttle routes, times, stops for both day and night.

---

### Location

Periphery of campus along shuttle routes (Bancroft, Oxford, Hearst, Gayley, etc.).



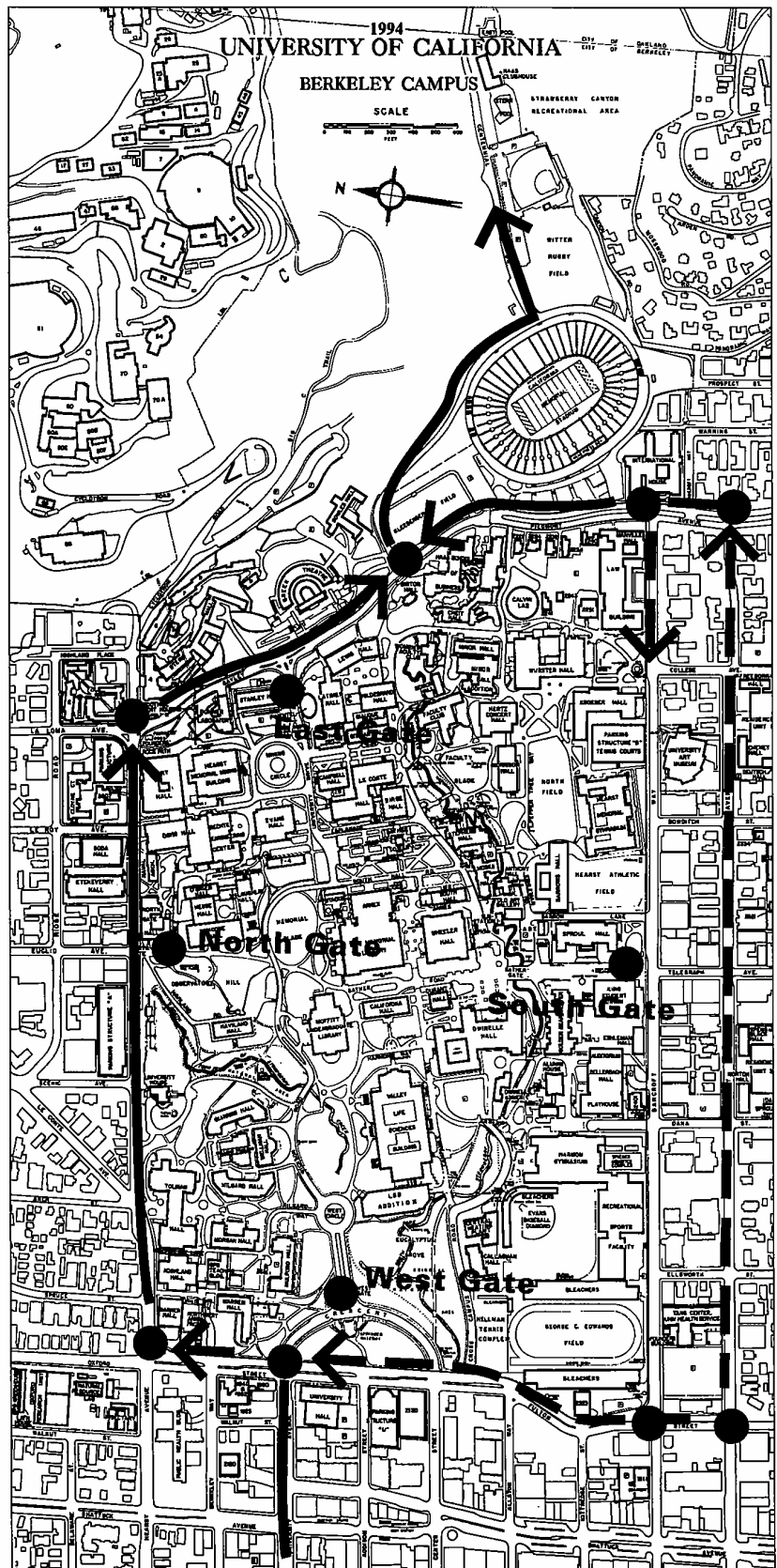

Sign Type D-5 Location Plan

# Directional Signage



## D-5

---

### Sign Type D-5

Signs located at major intersections around the campus could give directional clues to the visitor about difficult to find destinations such as the "Hill Area." These destinations would be associated with landmarks on campus (East Gate) to provide additional orientation for the visitor.

We recommend that an official name be developed for places like the "Hill Area." This will make it possible to avoid long lists of tenant names on the signage that are impossible for vehicular traffic to scan quickly.

---

### Message

Listing of landmarks and destinations with directional arrows. Destinations could include the "Hill Area," Clark Kerr Campus, and Golden Bear Field.

---

### Location

Signs to be located at periphery of campus.

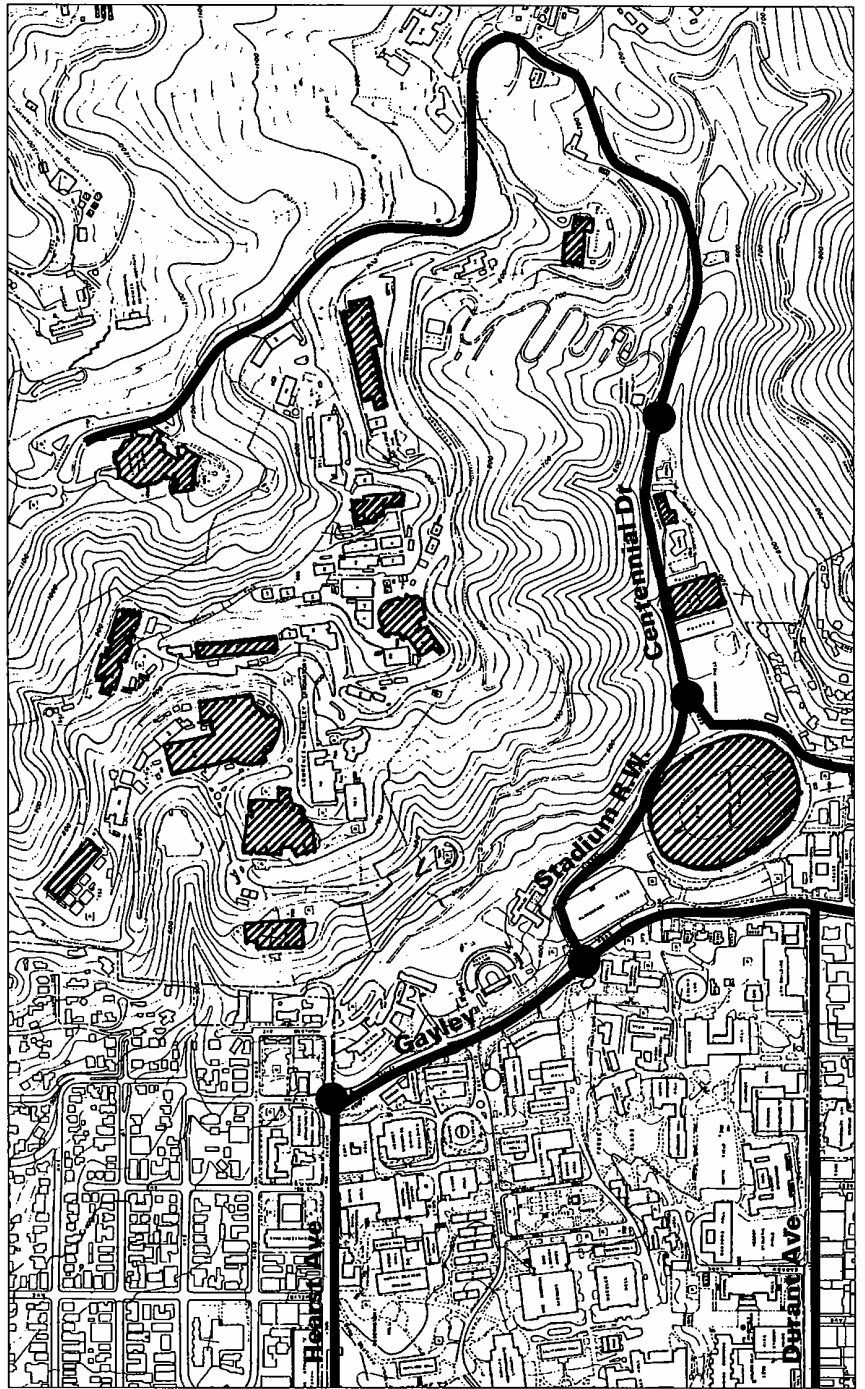

**Sign Type D-6 Location Plan**

# Directional Signage

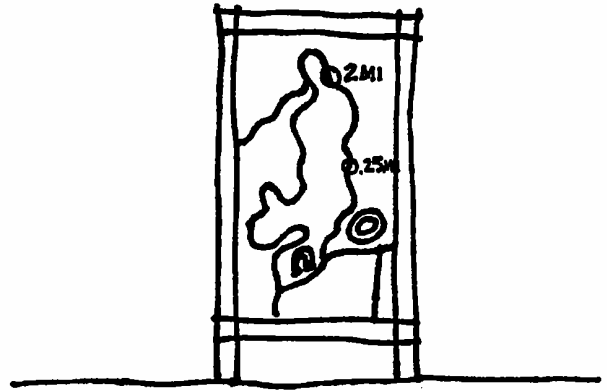

## D-6

---

### Sign Type D-6

Maps placed at entrance roads to the "Hill Area" and along Centennial Drive could call out the distance to public destinations. This would alleviate a newcomer's feeling of being lost and/or to avoid getting lost. In addition, a development of consecutive addressing systems for "Hill Area" tenants would make it easier to understand, relatively, where a destination is. This would benefit everyone, including service individuals such as delivery persons.

---

### Message

Map of the Hill Area and Clark Kerr Campus with public destinations noted by name, consecutive street address, and distance from a "you are here" indicator.

---

### Location

At entries to the Hill Area and along Centennial Drive.

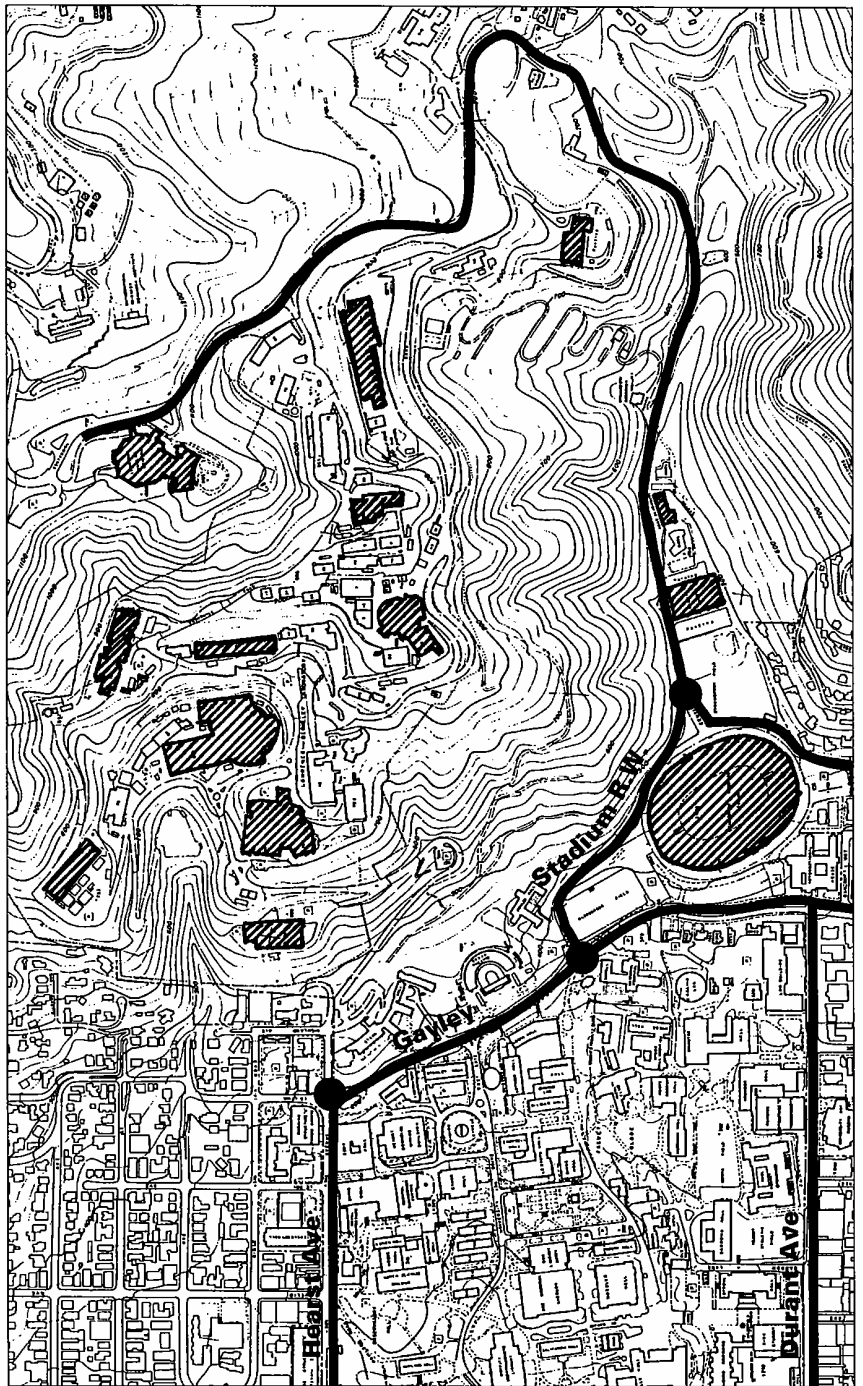

**Sign Type D-7 Location Plan**

# Directional Signage

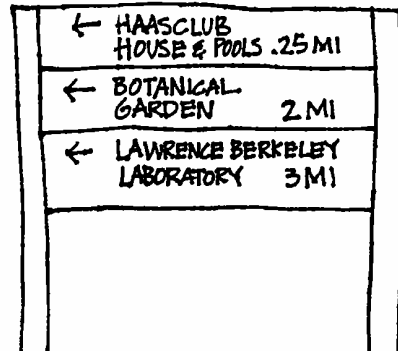

## D-7

---

### Sign Type D-7

Existing post and panel signs should be changed incrementally. Reduce the number of messages per sign to as few as possible. This will enable vehicular traffic to scan the signs more quickly. Currently, all messages on the signs are of equal importance. The signage should place more emphasis on buildings that are public like the Lawrence Hall of Science. If possible, list distance to the facility (similar to Sign D-6) to help locate the building.

---

### Message

Facility name, mileage, and directional arrow.

---

### Location

As currently located on campus.

# Regulatory Signage

Public and permit parking information is covered in this category as well as accessible signage and regulatory signage.

**R-1 Parking Times and Fees**

**R-2 Accessibility Information**

**R-3 Regulatory Information**

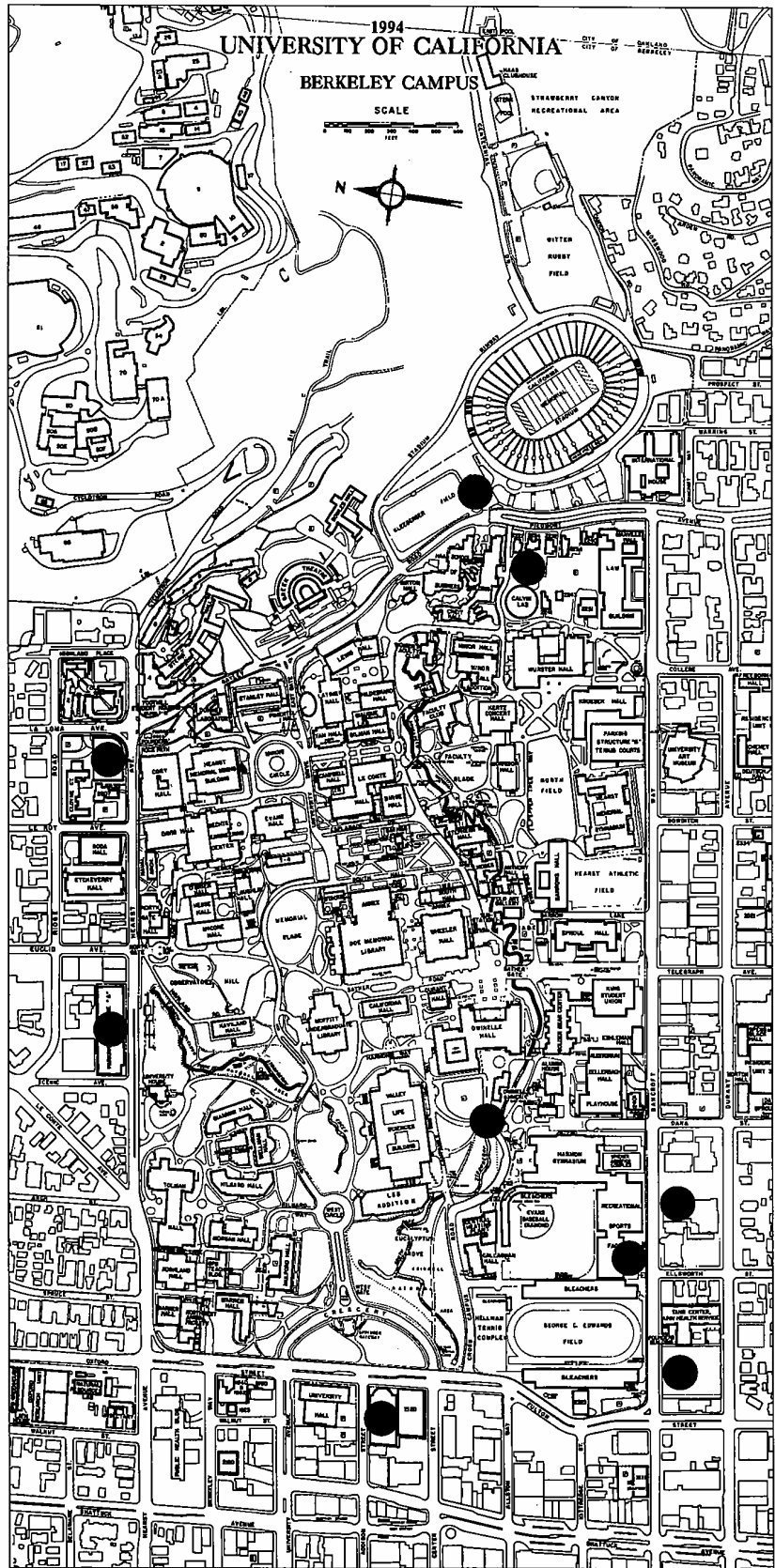

Sign Type R-1 Location Plan

This map indicates a few of the signs required.



# Regulatory Signage

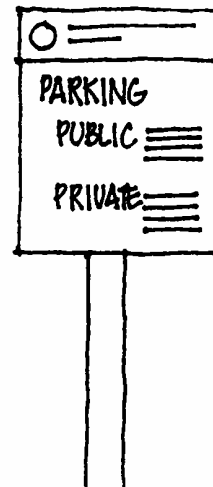

## R-1

---

### Sign Type R-1

A major part of the regulatory sign system is the parking identification sign on the campus. This sign currently contains a vast amount of information regarding both when the lot is used for permit parking and when it is used for public parking. The proposed sign is to be simple in its message so that it is easier to read. The sign would include the "University of California, Berkeley" identity since it would be placed at the periphery of the Campus.

---

### Message

Public parking - times and fees.  
Permit parking - type, times, and fees.  
University of California, Berkeley

---

### Location

Entrances to U.C. parking areas.

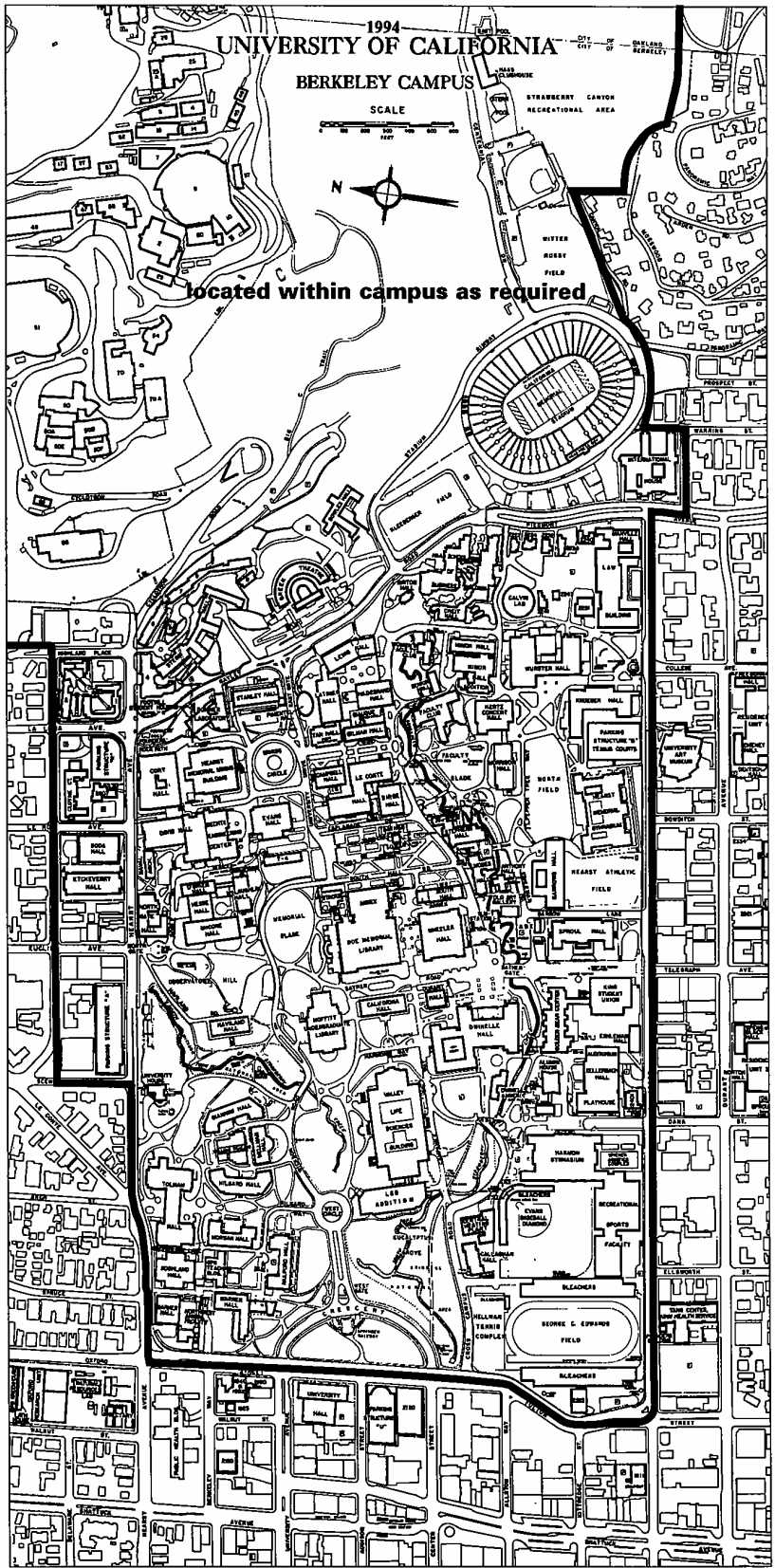

Sign Type R-2 Location Plan

# Regulatory Signage

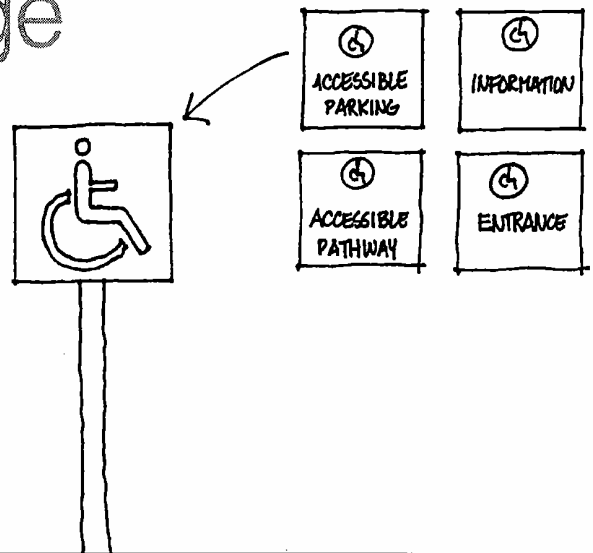

## R-2

---

### Sign Type R-2

ADA requirements are translated into standard sign graphics which communicate accessible building entrances, parking, pathways and information. These signs must meet the federal ADA requirements, yet still fit into the overall family of signs for the Campus.

---

### Message

Required messages for building entrances and parking areas plus additional signs for pathways that meet ADA standards and ADA information areas.

---

### Location

As required for both on and off-campus locations (to be determined by the campus).

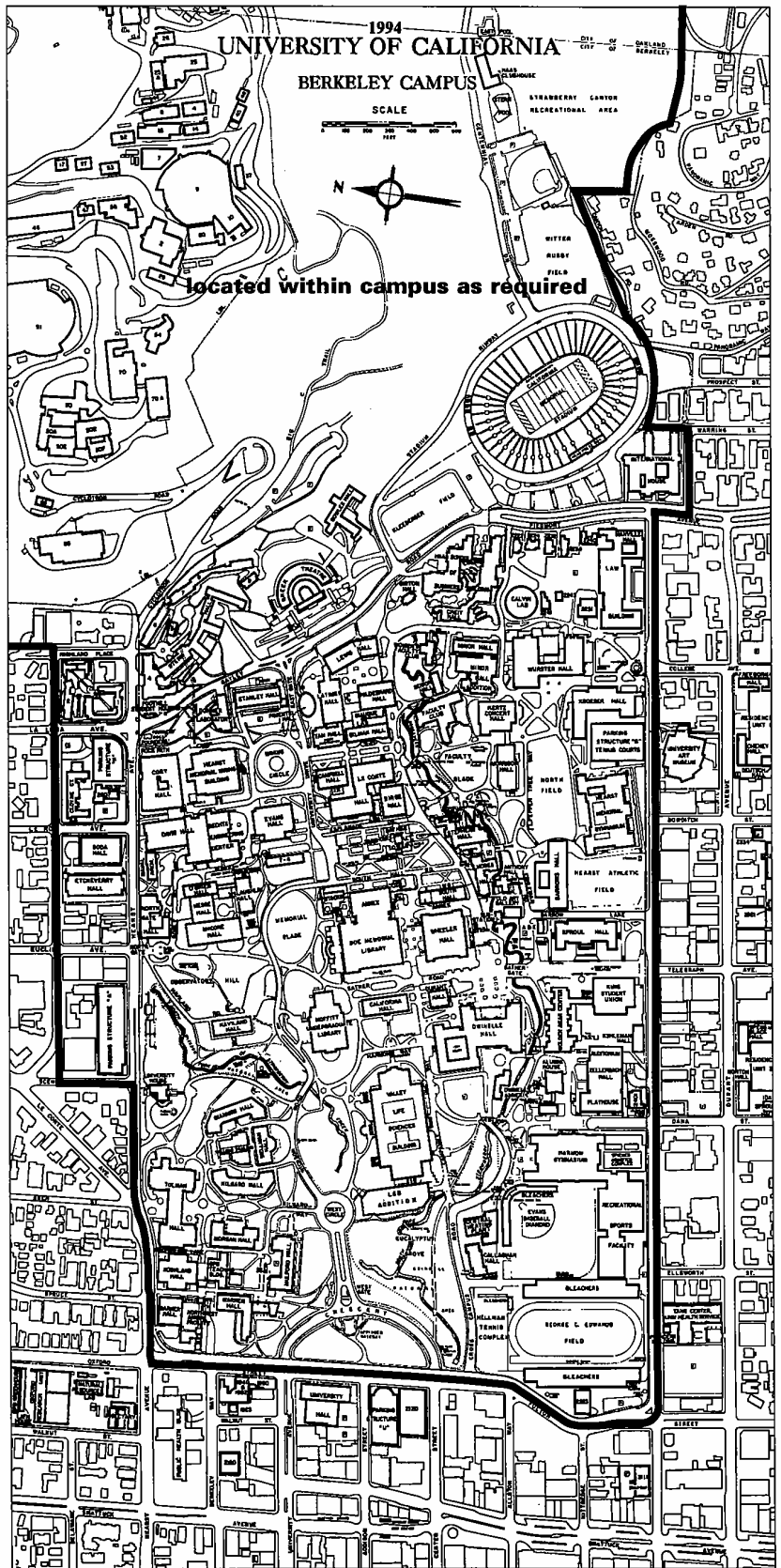

**Sign Type R-3 Location Plan**

# Regulatory Signage

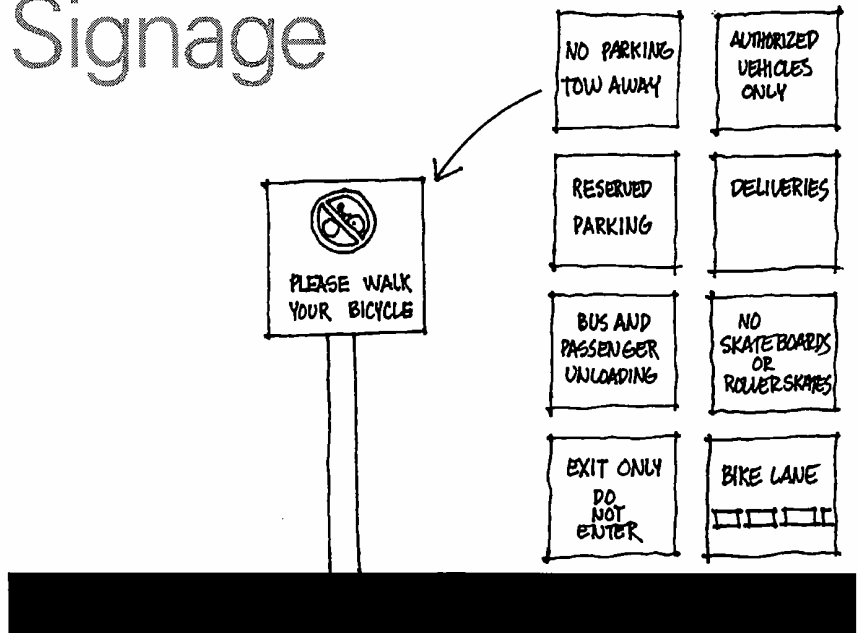

## R-3

### Sign Type R-3

A vast array of regulatory signs are and will be required on the campus - most relating to parking or regulating vehicle movement. These signs should be placed carefully on campus and kept to a minimum. The signs should be standardized and not visually obtrusive.

### Message

Regulatory message as required, phrased positively rather than negatively.

### Location

As required (to be determined by the campus).

# Guidelines

The information presented here is a guide to those who will implement these guidelines with the specific needs and regulations for exterior signage at U.C. Berkeley. The Guidelines are intended to provide a framework to the signage for the University so that signs added over time will appear to be part of a family.

**These guidelines are not a compendium of specification and materials or a catalog from which signs can be ordered.**

The following is the framework upon which the family of signs at U.C. Berkeley should be developed.

- **Overview**
- **Serif and Sans Serif Typefaces**
- **Serif and Sans Serif Arrows**
- **University Identifiers**
- **Header Panels**
- **Color Palette**
- **Cartography**
- **Fabrication**

# Guidelines

## Overview

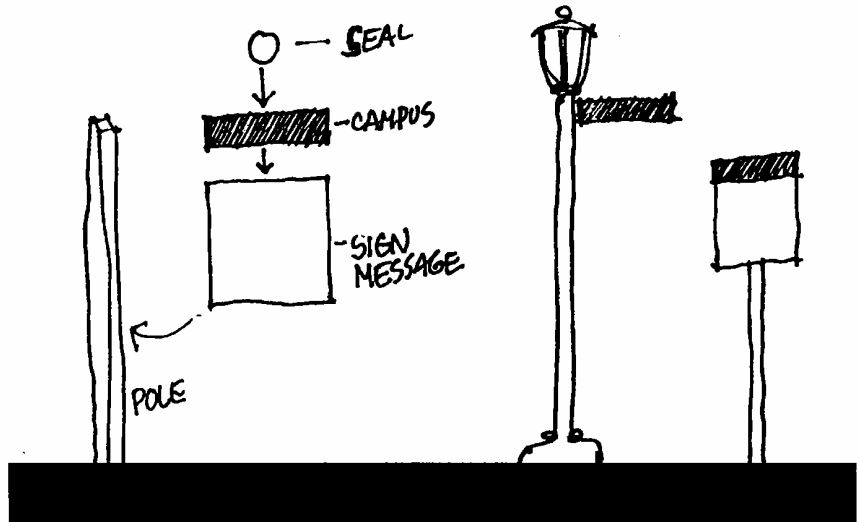

The graphic system is a collection of components that can be assembled in a variety of ways to provide unity to the campus yet offer a wide range of diversity. The campus seal and other logos related to the campus may be used. The name University of California, Berkeley would appear in a horizontal band below the symbol which may or may not associate with the sign message panel. The sign message would be on a simple panel. This sign system can be building, pole, or light fixture mounted.

These guidelines are generally described by two sign versions and the common elements that comprise each. The intent is that more than one sign type will be necessary by the campus but that all signs will be developed using the same basic elements that include typeface, color and materials.

The two sign versions shown below are meant to establish a timeless and classic base for the visual vocabulary of the sign program.

All of the examples shown were created on a Macintosh computer in the program Illustrator 5.5 and are available to be used as an electronic template for the creation of new signage.

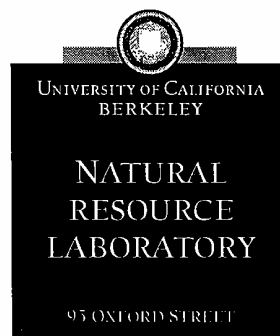

The above is an example of the general appearance of Informational Signage.

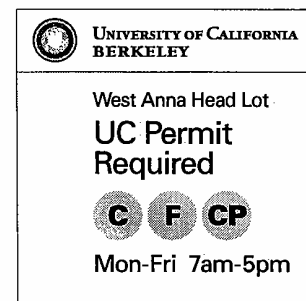

The above is an example of the general appearance of Directional & Regulatory Signage.

# Guidelines

## Serif Type

The following are always set in  
Goudy's University of California:  
• **University Identification**  
• **All text on Informational Signage**

---

### **Goudy's University of California Old Style Roman**

In 1936 the University commissioned Frederic W. Goudy to develop for exclusive use by the University a typeface. Originally named University of California Oldstyle, the face was first used in 1940 to commemorate the 500th anniversary of Guttenberg designing moveable type. The face was carefully translated for electronic technology by using lightly inked proofs taken from unused type cast from Goudy's original matrices. This font is available on disk from Richard Beatty Designs, 2312 Laurel Park Highway, Hendersonville, NC 28739, 704 696-8316.

---

ABCDEFGHIJKLMN  
OPQRSTUVWXYZ  
abcdefghijklmnopq  
rstuvwxyz

---

### **Goudy's University of California Old Style Roman Small Caps** also Goudy's University of California Titling

---

ABCDEFGHIJKLMNOP  
QRSTUVWXYZ

---

### **Goudy's University of California Old Style Bold**

This face was recently commissioned for the University Signage Program. This bold version was developed to maintain the character of the Roman face and to achieve greater legibility on the sign panels. The font is available on disk from Richard Beatty Designs.

---

ABCDEFGHIJKLMN  
OPQRSTUVWXYZ  
abcdefghijklmnopqr  
stuvwxyz

---

### **Goudy's University of California Old Style Bold Small Caps** also Goudy's University of California Titling Bold

---

ABCDEFGHIJKLMNOP  
QRSTUVWXYZ

---



# Guidelines

## Sans Serif Type

The primary typeface is Univers 55. A hierarchy of information is to be established through the use of different sizes of Univers 55. If a bold face is absolutely necessary, Univers 65 may be used.

- The following are always set in Univers:
- All text on **Directory Signage**
  - All text on **Regulatory Signage**

### Univers 55

The primary sans serif font used in the sign program is Univers 55.

Both this font and the style shown below are available from Adobe Systems Incorporated, 1585 Charleston Road, P.O. Box 7900, Mountain View CA 94039-7900, (800) 445-8787

---

ABCDEFGHIJKLMN  
OPQRSTUVWXYZ  
abcdefghijklmnop  
qrstuvwxyz

---

### Univers 65

The sans serif font Univers 65 may be used to highlight information.

---

**ABCDEFGHIJKLMN**  
**OPQRSTUVWXYZ**  
**abcdefghijklmnop**  
**qrstuvwxyz**

---

# Guidelines

## Serif Arrow

Arrows are the most widely used and universally understood directional device. For design consistency on signage layouts for the University, select one of the two arrows shown depending on the typestyle which appears on the message panel.

### Serif Arrow

The arrow shown on this page is to be the only directional device used when the primary message panel font is serif. An arrow should be centered under the line (or lines) of information it serves. If more than one arrow is used on a sign, the arrows should be center aligned.

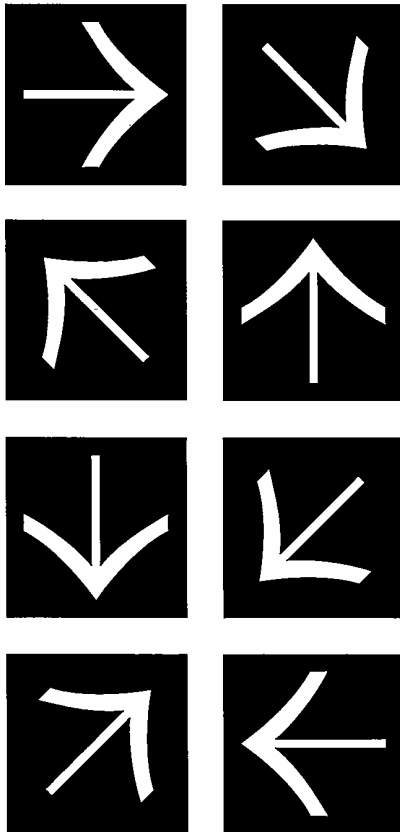

Proper alignment for serif or sans serif directional arrows.

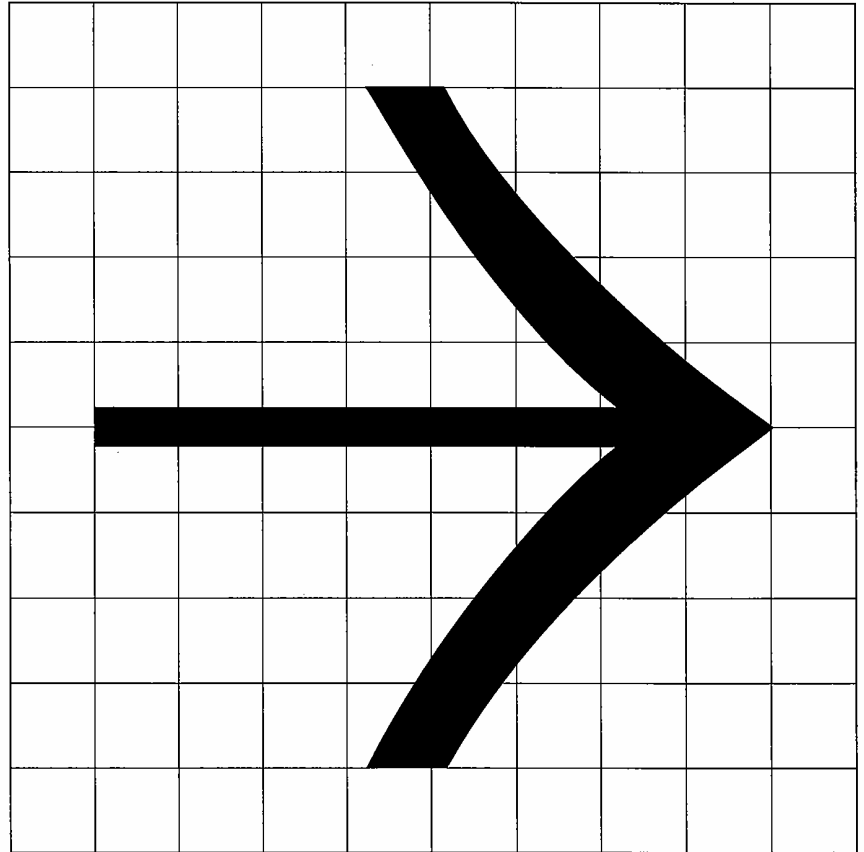

CAMPUS

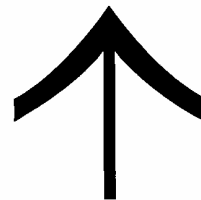

# Guidelines

## Sans Serif Arrow

### **Sans Serif Arrow**

The arrow shown on this page is to be the only directional device used when the primary message panel font is sans serif. An arrow should be placed to the left of the line (or lines) of information it serves. If more than one arrow is used on a sign, the arrows should be aligned flush left.

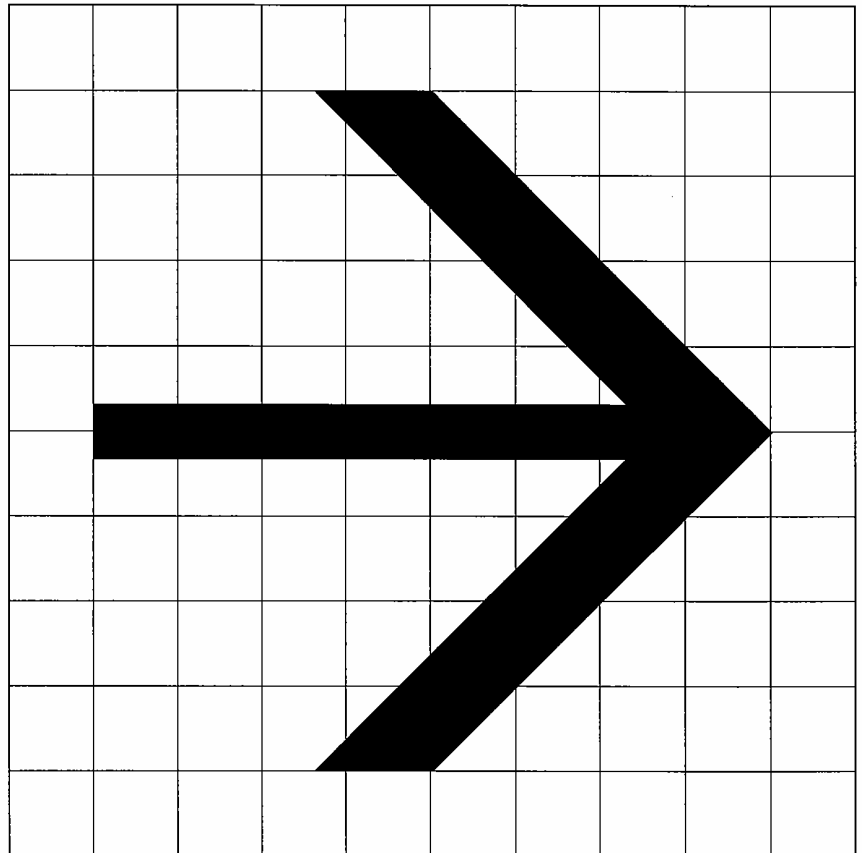

# Guidelines

## University Identifiers

### Primary identifier

The seal of the University, designed by Tiffany and Company, was adopted by the Regents in 1910. When the seal of the University of California is used on the campus sign program, it is to be reproduced in 3 colors: C-1 (blue), C-2 (gold), and C-3 (white).

Artwork to be provided by  
Mr. Gregg Young, Development  
Department, University of California,  
Berkeley (510) 642-7748



---

### Alternate Identifiers

It may be appropriate at times to customize the sign program, to fit the needs of specific departments by using alternative identifiers. If an Identifier like the examples on the right are considered for use in the sign program the symbol should be reviewed by the Signage Review Committee.

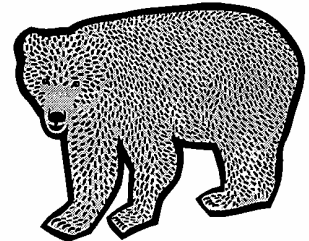
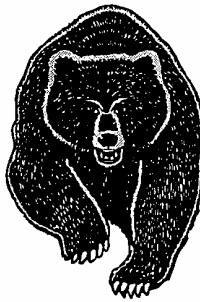

# Guidelines

## Header Panels

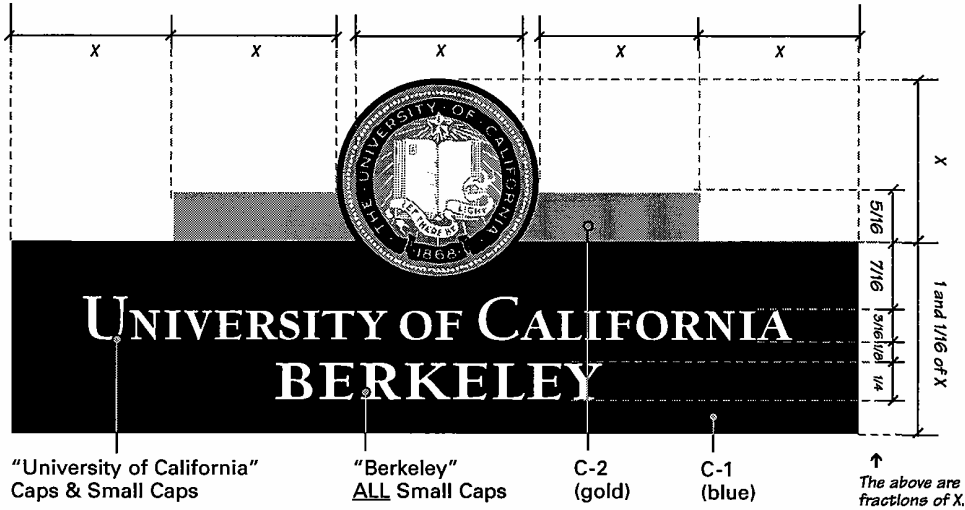

### Informational Signage Header Panel

Goudy's University of California Old Style Bold  
to match color C-3 (white)



The use of alternative  
identifiers should be  
approved by the Signage  
Review Committee.

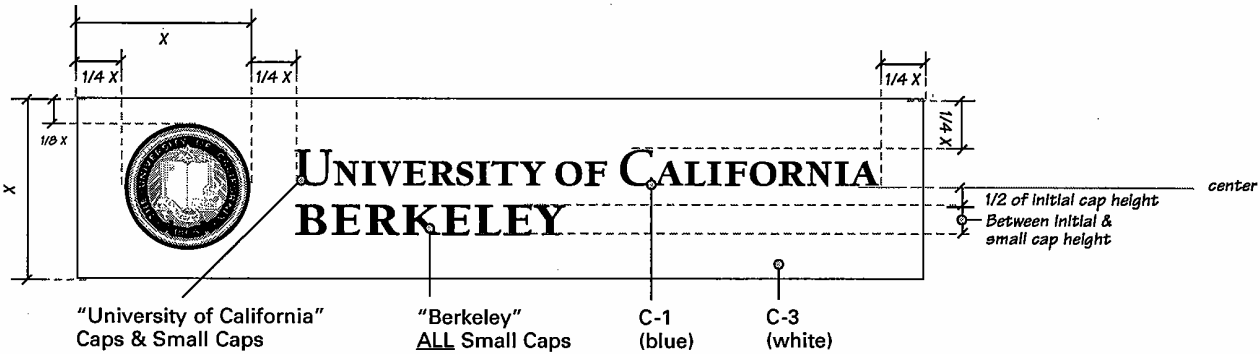

### Directional & Regulatory Signage Header Panel

Goudy's University of California Old Style Bold

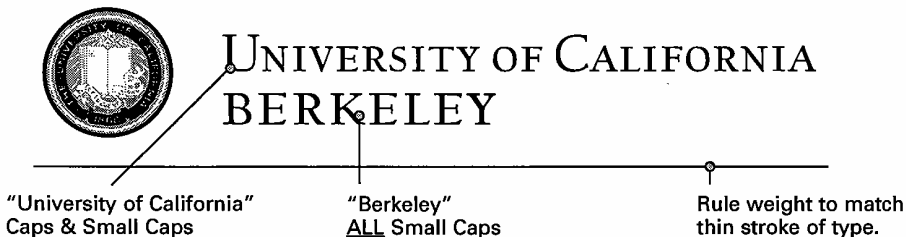

### Regulatory Flyer Header Panel

Goudy's University of California Old Style Roman

# Guidelines

## Color Palette

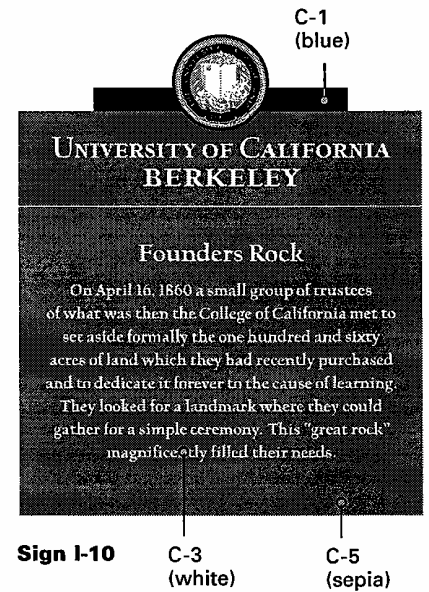
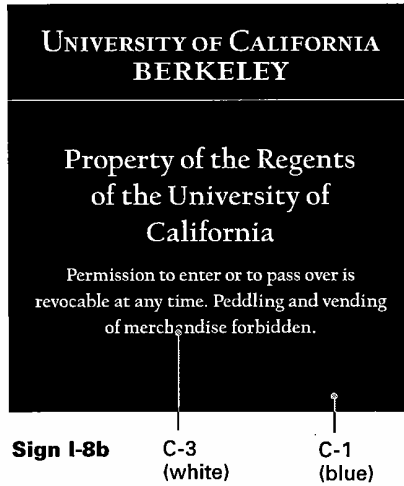
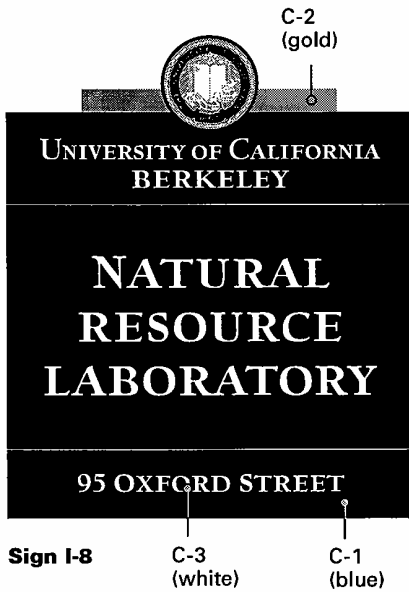

**Sign I-5**

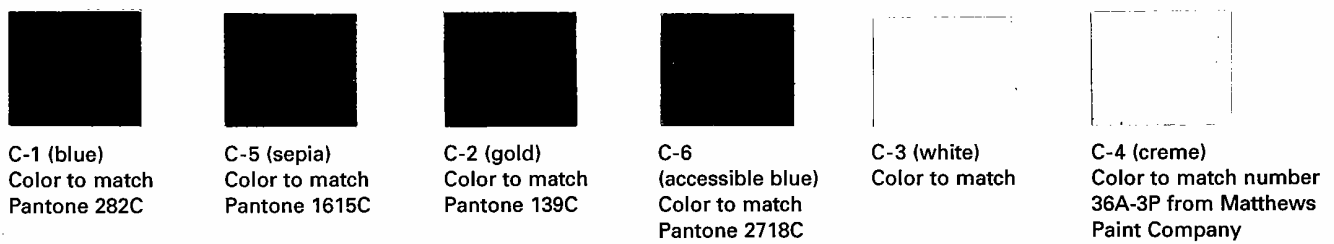

# Guidelines

## Color Palette

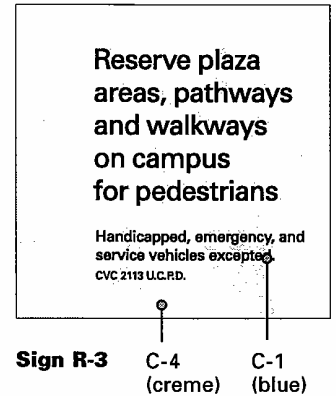
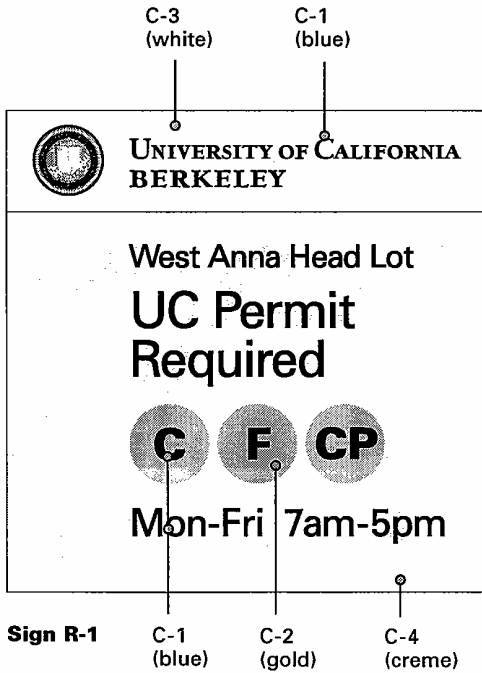

# Guidelines Cartography

The reference map is the best source for way-finding on the campus. It provides location information, showing how the positions of various buildings, streets, and pathways relate to each other.

## existing

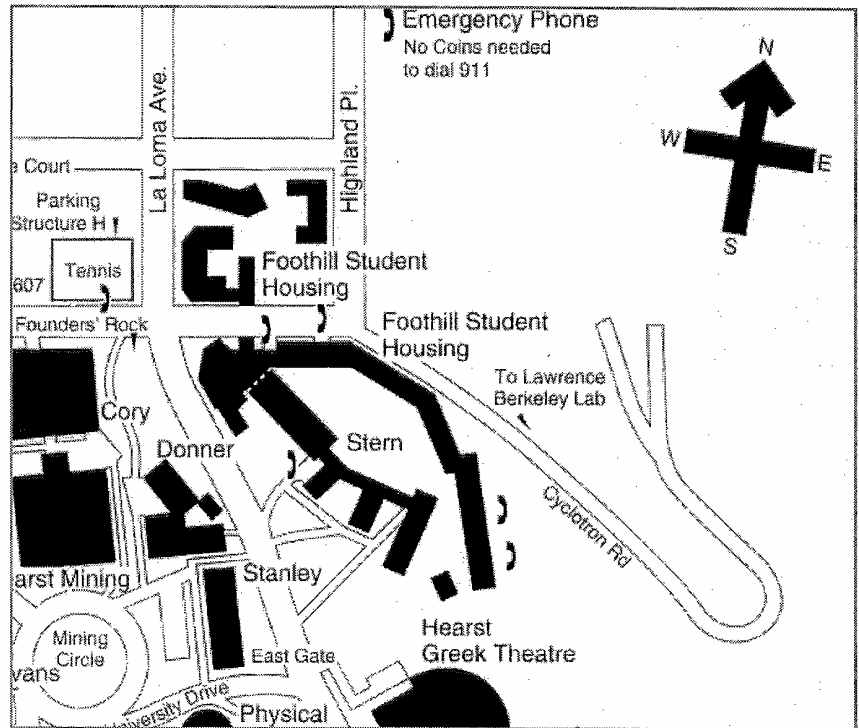

## new

- Map generated electronically would make frequent updates easier to implement.
- Streets in white on a field of color eliminates the need for outlining that can create confusing negative space.
- Building names are clearly marked on the representation of the structure.
- A legend of all the buildings in alphabetical order makes for an easy-to-use index.
- Arrows should be clearly directional.
- Distinctive icons increase legibility.
- Varying type styles and sizes create a clearer hierarchy of information.

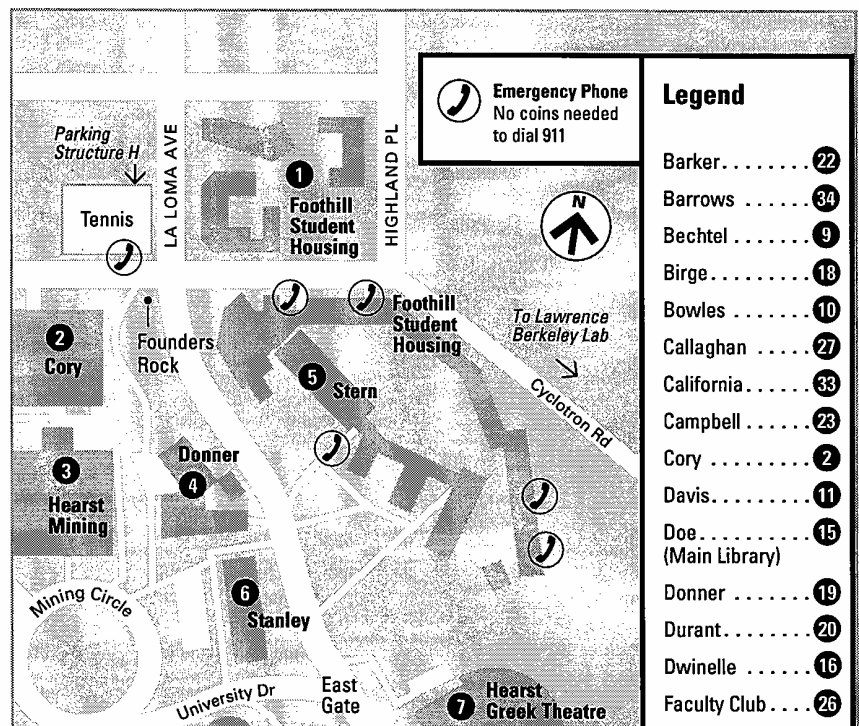



# Guidelines

## Fabrication

When possible fabrication and maintenance of the sign program could occur on campus. The Physical Plant and Parking and Transportation offices are currently the largest fabricators of exterior signs on campus and have some ability to maintain the signage. Both departments should expand their computer systems to include Macintosh computers with Illustrator and Quark Express software. The Mac operating system includes the ability to read and write DOS format files and diskettes. Illustrator will import and export DXF format files to assure compatibility with the widest possible choice of computer and CAD software, including Autocad.

### **METHOD 1**

#### **Baked porcelain enamel on steel**

Baked porcelain enamel is the most durable of the finishes. A porcelain frit is heat fired on a steel substrate.

Custom colors can be created and maintained.

This is not an in-house process although blank sign panels can be ordered and the campus could apply vinyl die-cut copy as required.

Graffiti can typically be removed because the surface of the baked enamel can resist extremely strong cleansing chemicals.

### **METHOD 2**

#### **Polyurethane enamel spray paint applied to aluminum.**

Polyurethane enamel spray paint is extremely durable although not graffiti resistant.

The painting process could be completed by U.C. Berkeley in-house with upgrades to the ventilation system and spray equipment as required.

Color matching and consistency in paint color is not a problem. Paint suppliers like Matthews create formulas for specific colors by weighing pigment and keeping records of the formula. Typically paints can be ordered and shipped within 24 hours.

It is important to select a paint supplier like Matthews whose product meets California EPA requirements.

Polyurethane paints are typically guaranteed for 5-10 years against fading or discoloration.

Vinyl die-cut or silkscreen copy could be applied to the painted sign panels.

# Sign Types

This section illustrates the guidelines applied to the 3 categories of signage: Informational, Directional and Regulatory. Some of the topics covered are: dimensions, proportions and mounting specifications. When determining final dimensions for the signage, it is our intent that the signs be pedestrian in scale, particularly on campus. The "park" setting of the campus should always be considered.

## **Informational**

**I-5, I-6, I-7, I-8, I-8a, I-8b, I-10**

## **Directional**

**D-4, D-3**

## **Regulatory**

**R-1, R-2, R-3**

# Sign Types

## Informational I-5

Streets and pathways are to be identified by simple blade signs. The signs should be blue (color C-1) with white copy (color C-3).

The seal of the University can be added to the typical street signs at major intersections and landmark locations.

See Header Panel in the Guidelines section for the proportional breakdown of these elements.

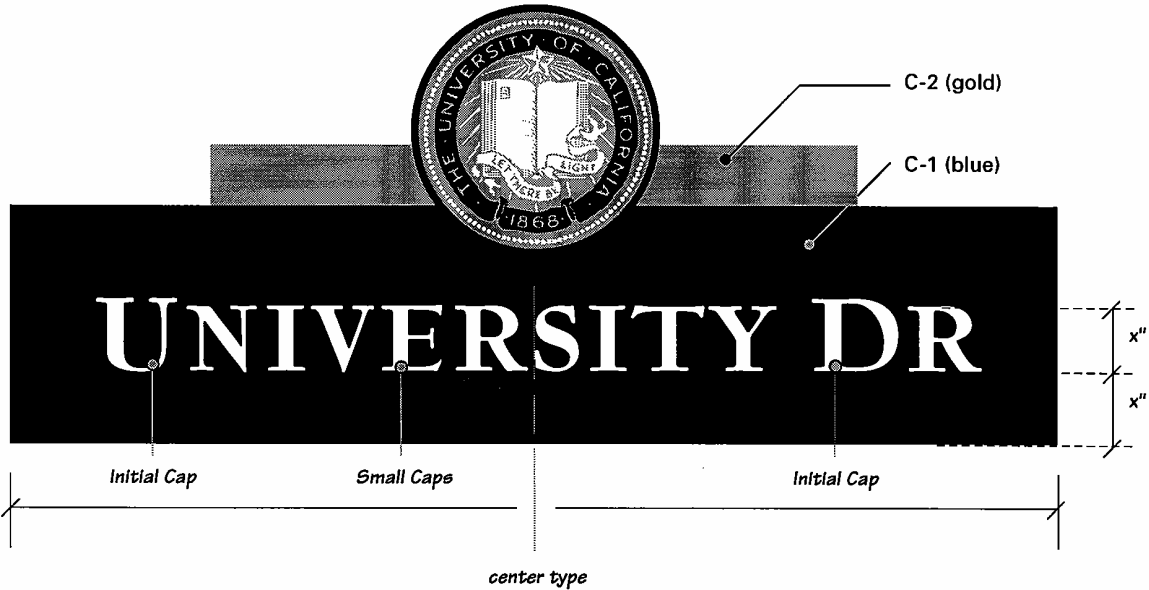

**Font:** Goudy's University of California  
Titling Bold Cap & Small Caps

**Letter Spacing:** The spacing is opened so that the letters do not touch one another.

**Options:** The type & background color can be reversed as shown.

**General Note:** The small caps in the Titling style are larger than the standard small caps. This makes for higher readability from a distance.

# Mounting Detail

## Informational I-5

**Identification Signs:** The following details are to show design intent. Actual sizes of signs, mounting hardware, and mounting height to be determined upon review of full size mock ups in the field.

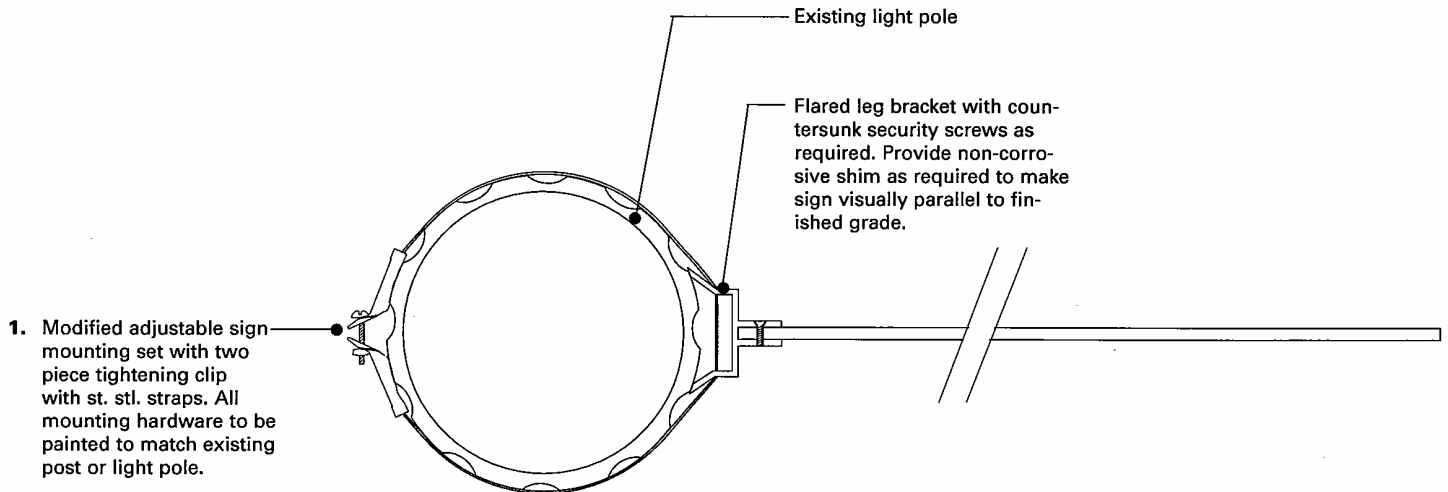

**Section A - A**  
Scale: 1/4" = 1"

2. Obtain consent to use historic light poles with proper campus authority when required.

3. **Sign Type R-5**  
1/4" thick aluminum plate spray coated with polyurethane enamel paint. Silkscreen copy with enamel ink.

4. Dress all edges of aluminum after cutting to size. Finish edges to match face.

5. Note sign is to be two sided.



**Detail**  
Scale: 3/16" = 1"

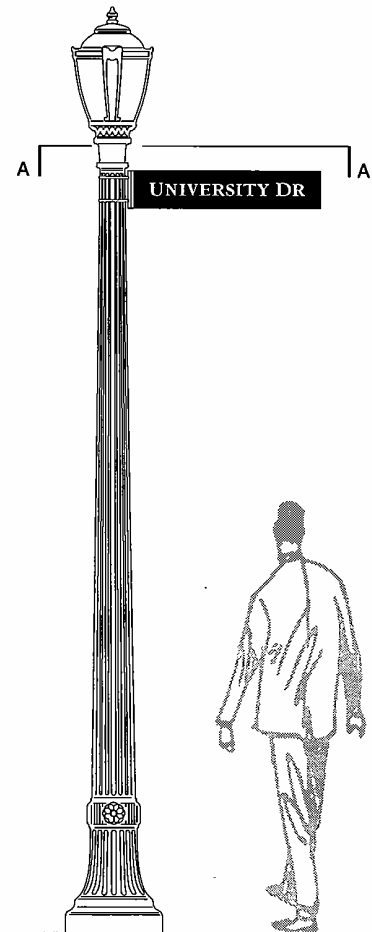

**Typical elevation**  
Scale: 3/8" = 1'-0"

# Sign Types

## Informational I-6, I-7

In addition to Goudy's University of California and Univers, the following typefaces may be used for sign types I-6 and I-7. They are excellent alternatives because they have proven to be classics that will not become outdated. Keep this in mind when selecting a typeface that is not shown here.

---

### Caslon

ABCDEFGHIJKLMN  
OPQRSTUVWXYZ  
abcdefghijklmnopq  
rstuvwxyz

---

### Garamond

ABCDEFGHIJKLMN  
OPQRSTUVWXYZ  
abcdefghijklmnopq  
rstuvwxyz

---

### Bodoni

ABCDEFGHIJKLMN  
OPQRSTUVWXYZ  
abcdefghijklmnopq  
rstuvwxyz

---

# Sign Types

## Informational I-6, I-7

---

### Futura

ABCDEFGHIJKLMN  
OPQRSTUVWXYZ  
abcdefghijklmnopq  
rstuvwxyz

---

### Gill Sans

ABCDEFGHIJKLMN  
OPQRSTUVWXYZ  
abcdefghijklmnopq  
rstuvwxyz

---

### Franklin Gothic

ABCDEFGHIJKLMN  
OPQRSTUVWXYZ  
abcdefghijklmnopq  
rstuvwxyz

---

# Sign Types

## Informational I-8

Mock-up of sign type to be reviewed in field to determine final size. Upon approval of a mock-up, select appropriate size square mounting post. See typical mounting details for design intent.

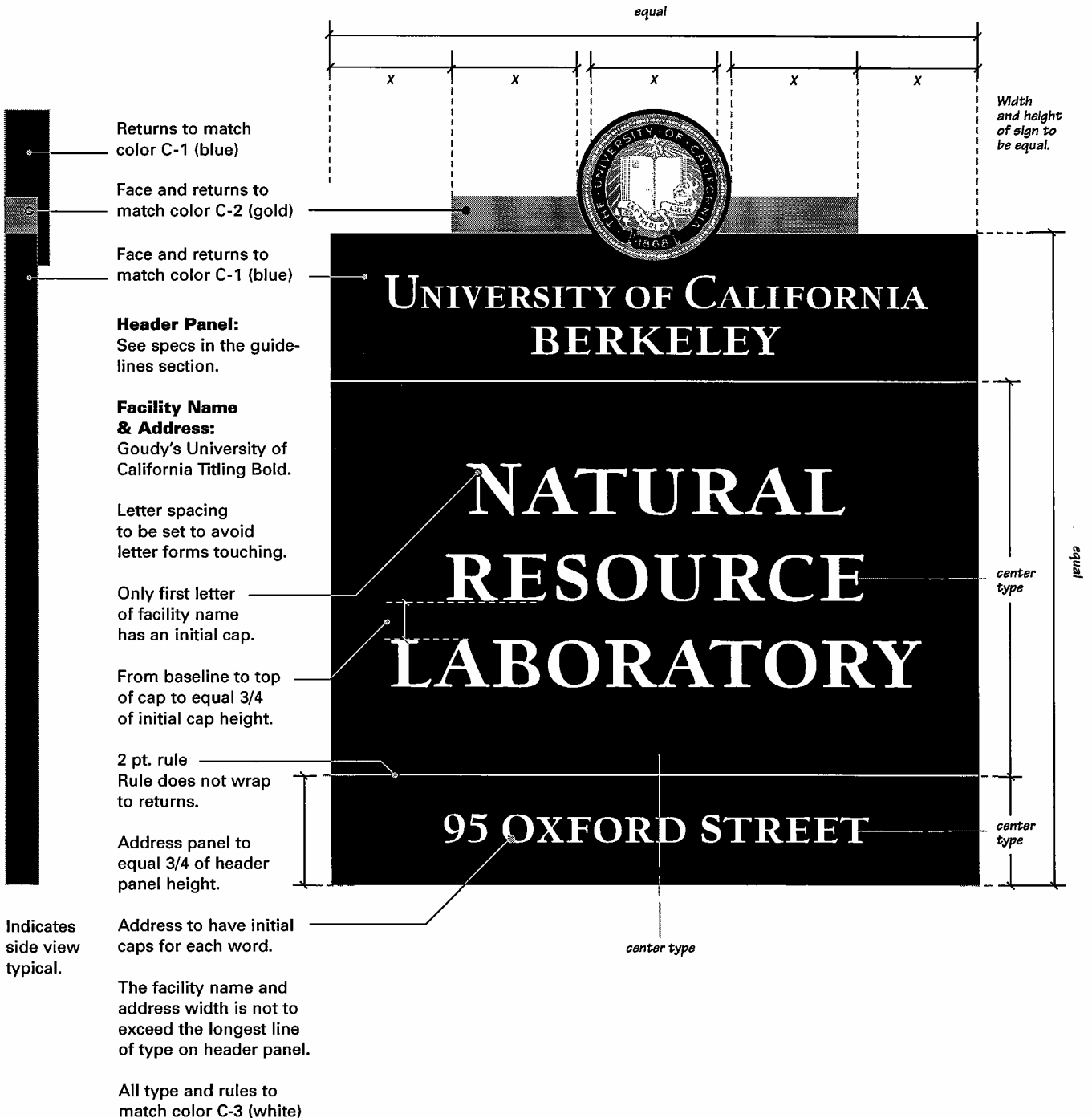

# Sign Types

## Informational I-8a

Mock-up of sign type to be reviewed in field to determine final size. Upon approval of a mock-up, select appropriate size square mounting post. See typical mounting details for design intent.

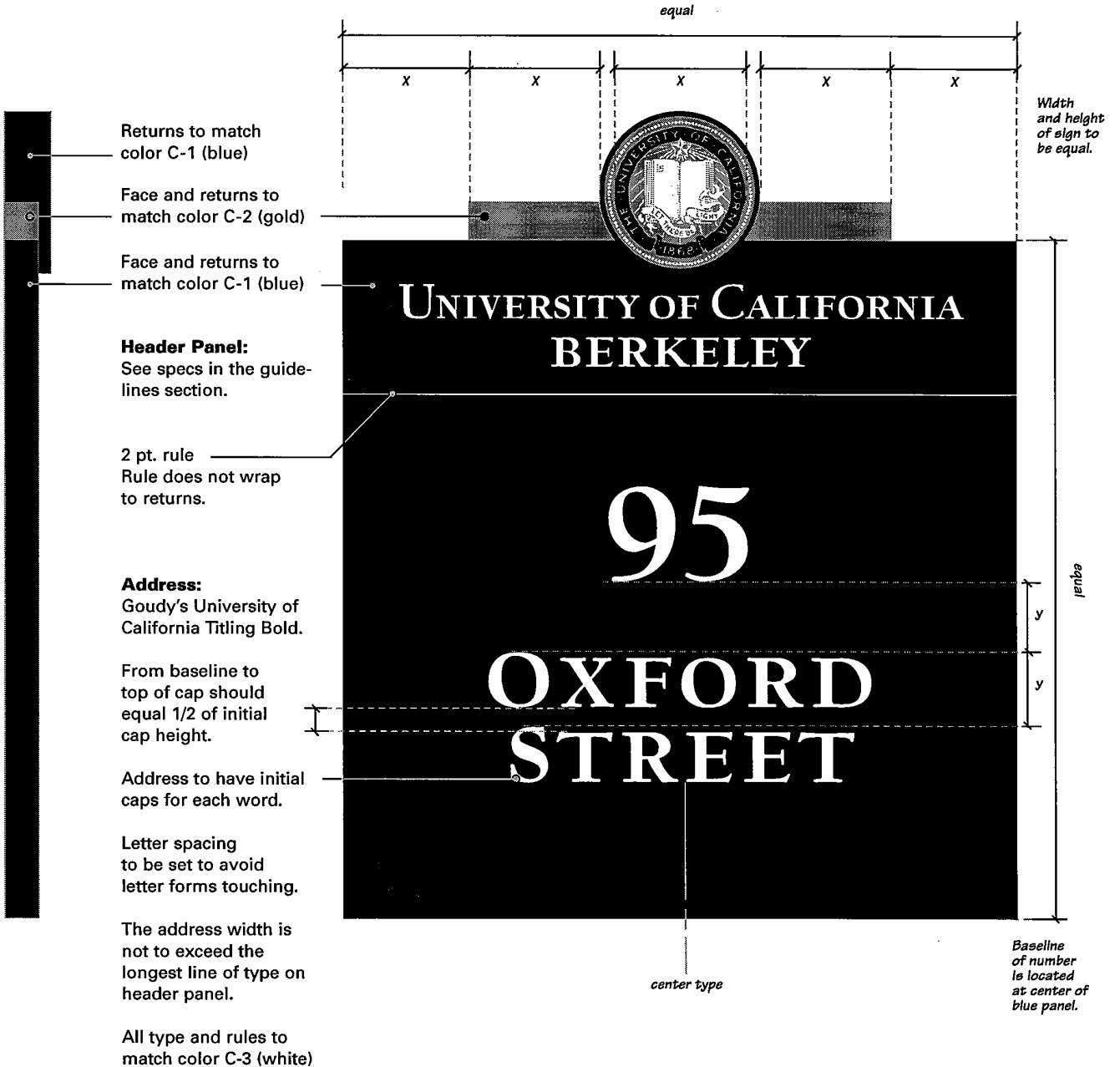



# Sign Types

## Informational I-8b

Mock-up of sign type to be reviewed in field to determine final size. Upon approval of a mock-up, select appropriate size square mounting post. See typical mounting details for design intent.

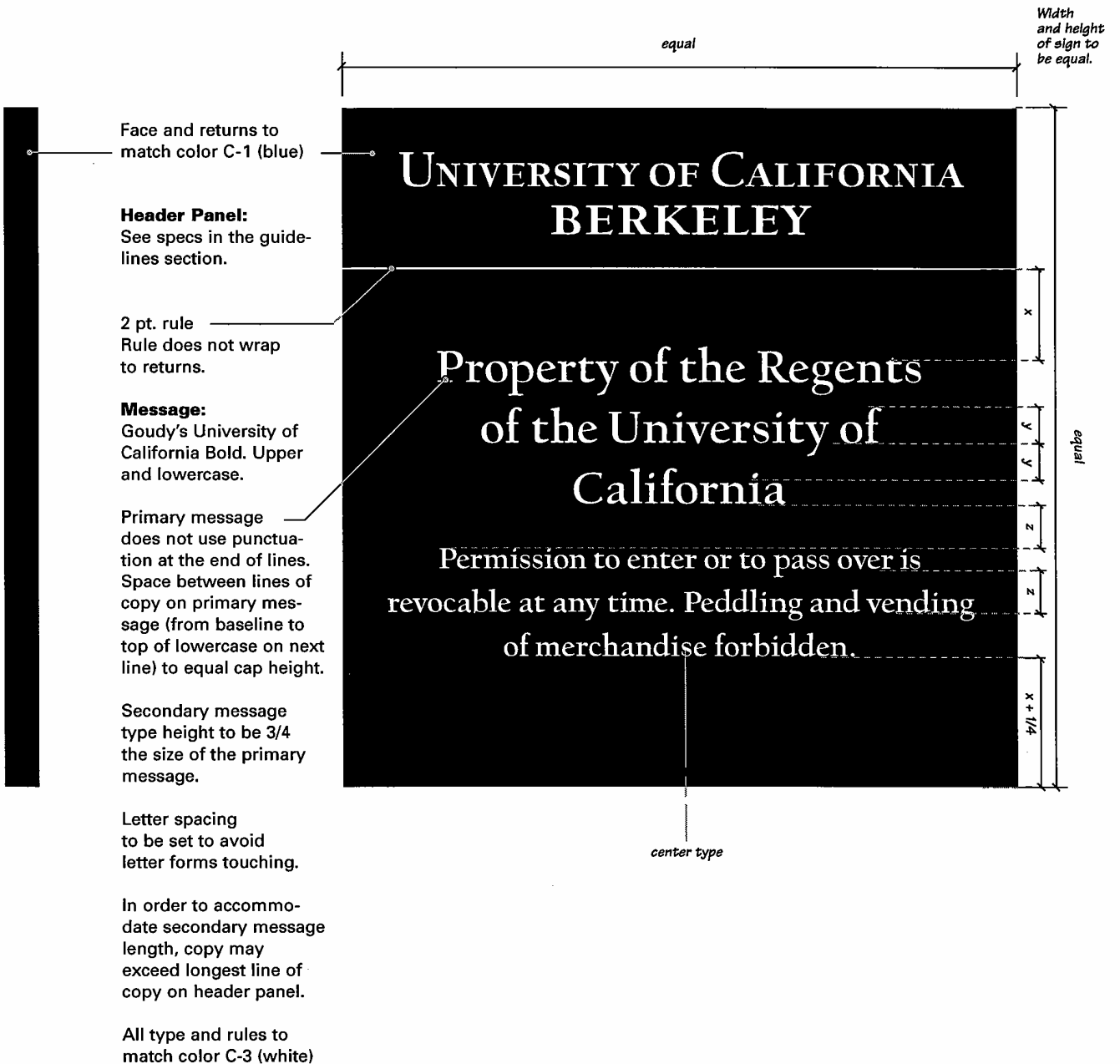

# Sign Types

## Informational I-10

Mock-up of sign type to be reviewed in field to determine final size. Upon approval of a mock-up, select appropriate size square mounting post. See typical mounting details for design intent.

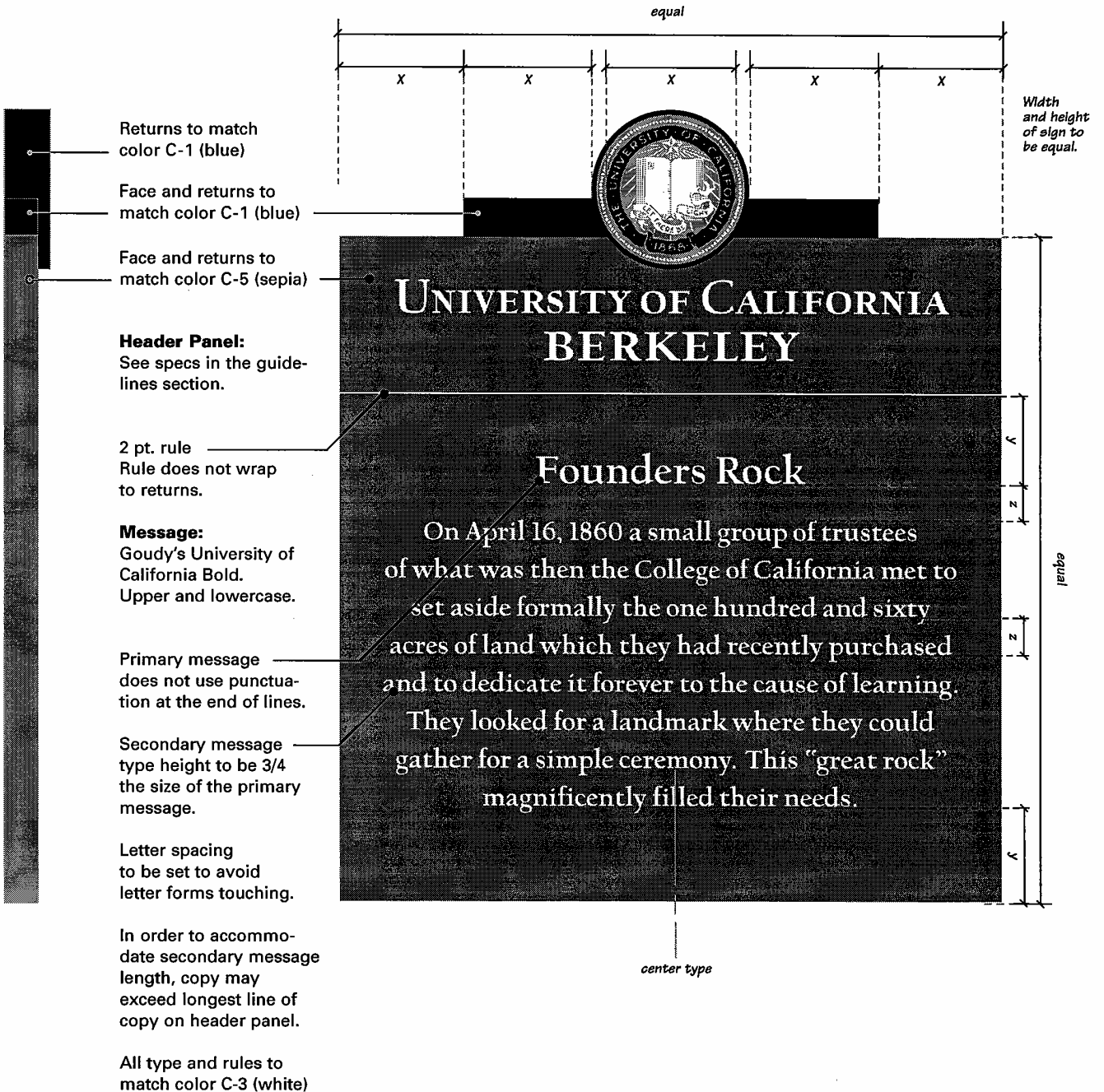

# Mounting Detail

## Alt. I-8, I-8a, I-8b, I-10

**Identification Signs:** The following details are to show design intent. Actual sizes of signs, mounting post, and mounting height to be determined upon review of full size mock ups in the field. If different sizes of signs are used, post size may need to be altered proportionally. Sign panels are to be constructed of 16 gauge steel; all surfaces to be in porcelain enamel. Sign panels are to be mounted to square posts (steel) with stainless steel security hardware as required.

Miter, weld corners, and grind smooth all joints prior to application of porcelain enamel.

Use st. stl. security hardware as required.

1. University seal, header, and message panel.
2. Back plate to be 16 gauge steel. All surfaces to be coated with porcelain enamel color C-1 (blue) except for sign type I-10, back plate to be color C-5 (sepia).
3. St. stl. hardware as required.
4. Adhesive as required.
5. Solid core as required.
6. Steel post with end cap painted to match campus standard - elephant's breath (dark grey) semi gloss.
7. Sign to mount flush to post.
8. **Sign Types I-8, I-8a, and I-10**  
Entire sign to be a single fabricated pan. Secure seal and message panel to back plate as required.  
Note: Back plate to be pre-attached to post as required. See sign layouts for colors of sign face and returns.
9. **Sign Type I-8b**  
Sign type I-8b does not use the seal of the University. The mounting post should be shortened to not align with the top of the sign panel.

Under-cut panel to meet flush. Sealant joints to have crisp even edge profile (typ).

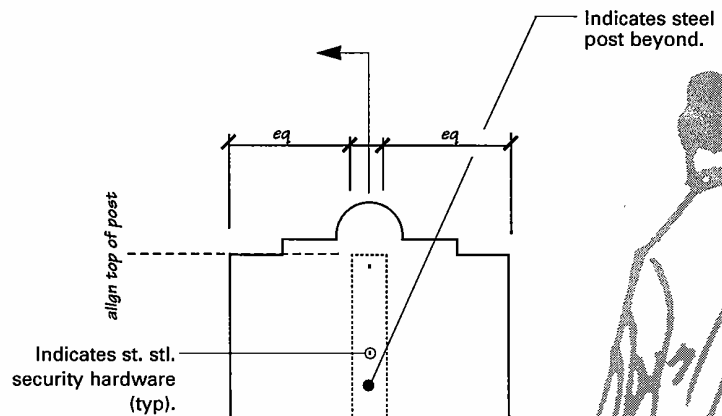

**Typical elevation**  
Scale: 3/4" = 1'-0"

**Section**  
Scale: 3" = 1'-0"

# Mounting Detail

## I-8, I-8a, I-8b, I-10

**Identification Signs:** The following details are to show design intent. Actual sizes of signs, mounting post, and mounting height to be determined upon review of full size mock ups in the field. If different sizes of signs are used, post size may need to be altered proportionally. Sign panels are to be constructed of 16 gauge steel; all surfaces to be in porcelain enamel. Sign panels are to be mounted to square posts (steel) with stainless steel security hardware as required.

Miter, weld corners, and grind smooth all joints prior to application of porcelain enamel.

Use st. stl. security hardware as required.

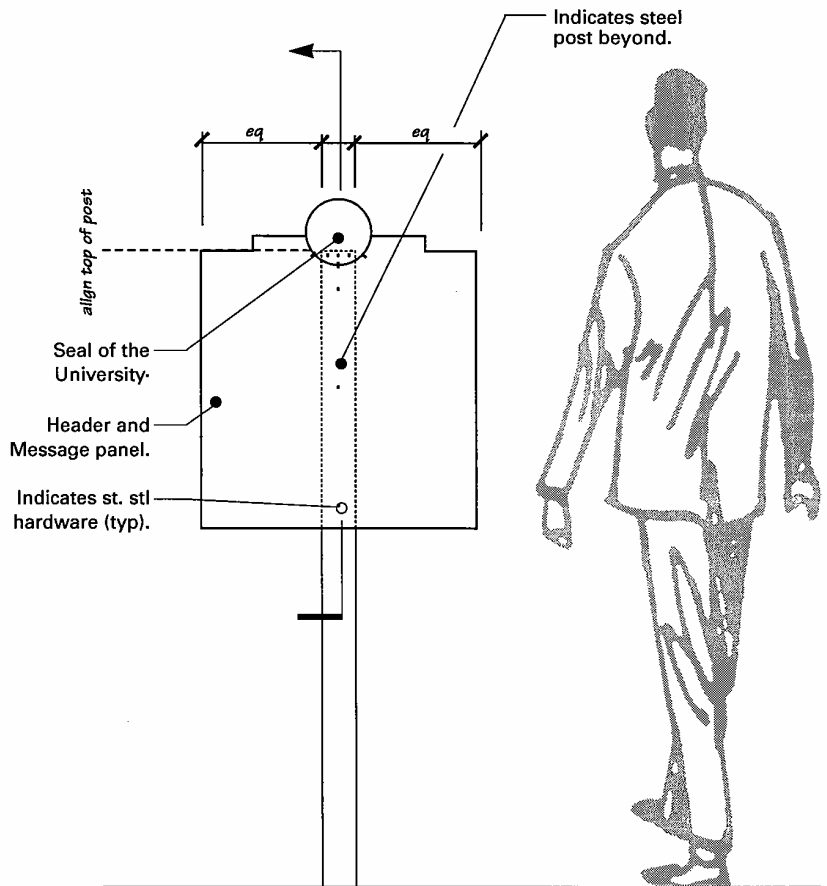
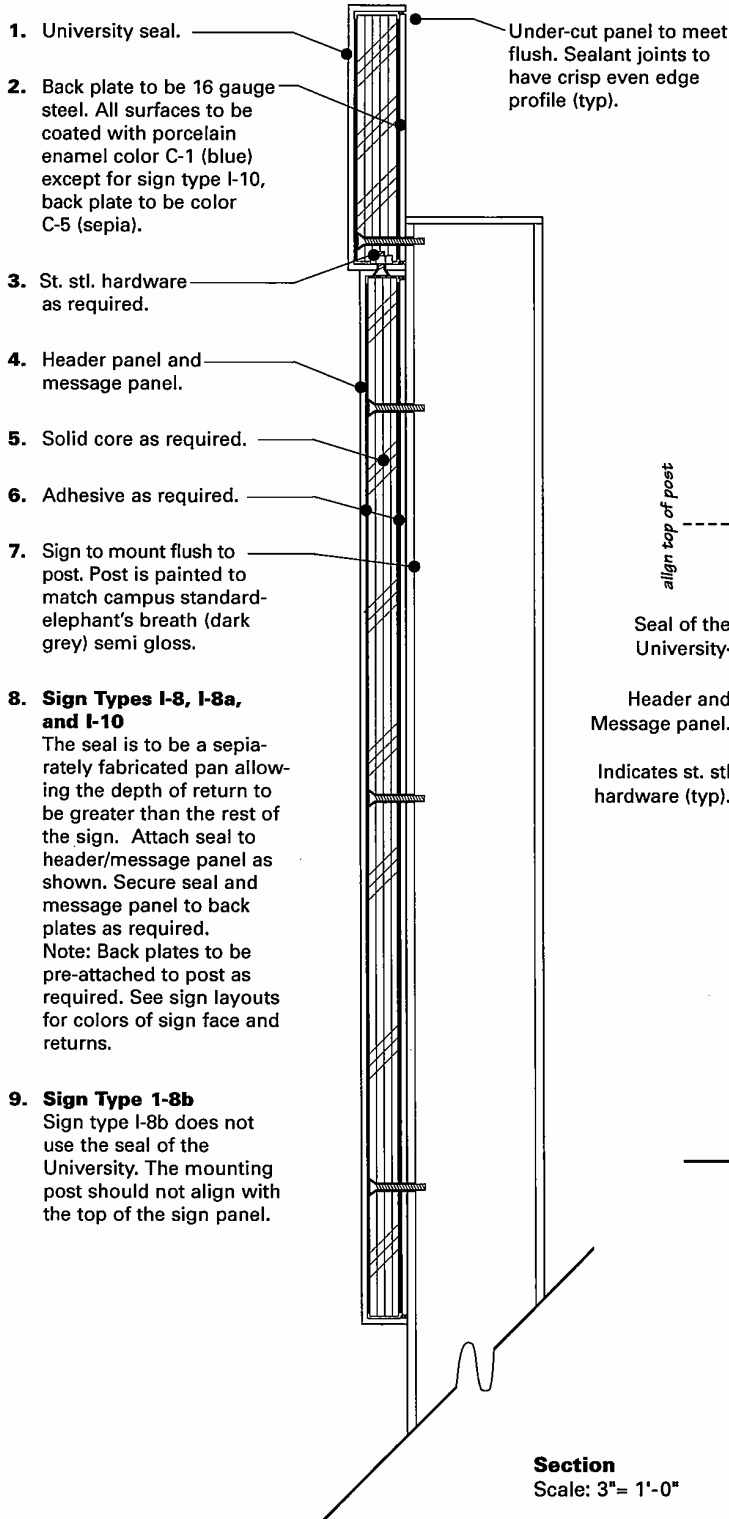

**Typical elevation**  
Scale: 3/4" = 1'-0"

**Section**  
Scale: 3" = 1'-0"

# Sign Types

## Directional D-3

Mock-up of sign type to be reviewed in field to determine final size. Upon approval of a mock-up, select appropriate size square mounting post. See typical mounting details for design intent.

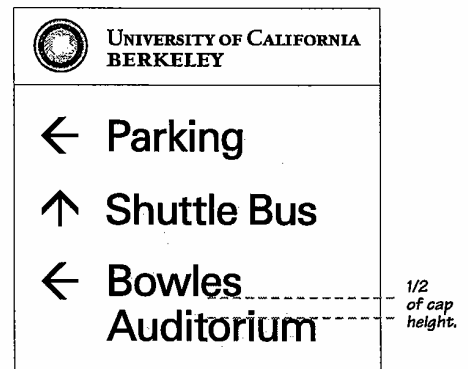
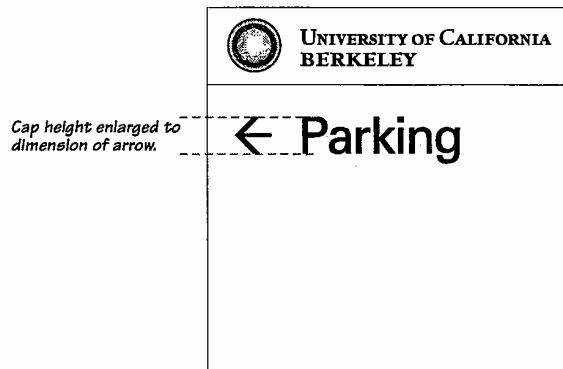
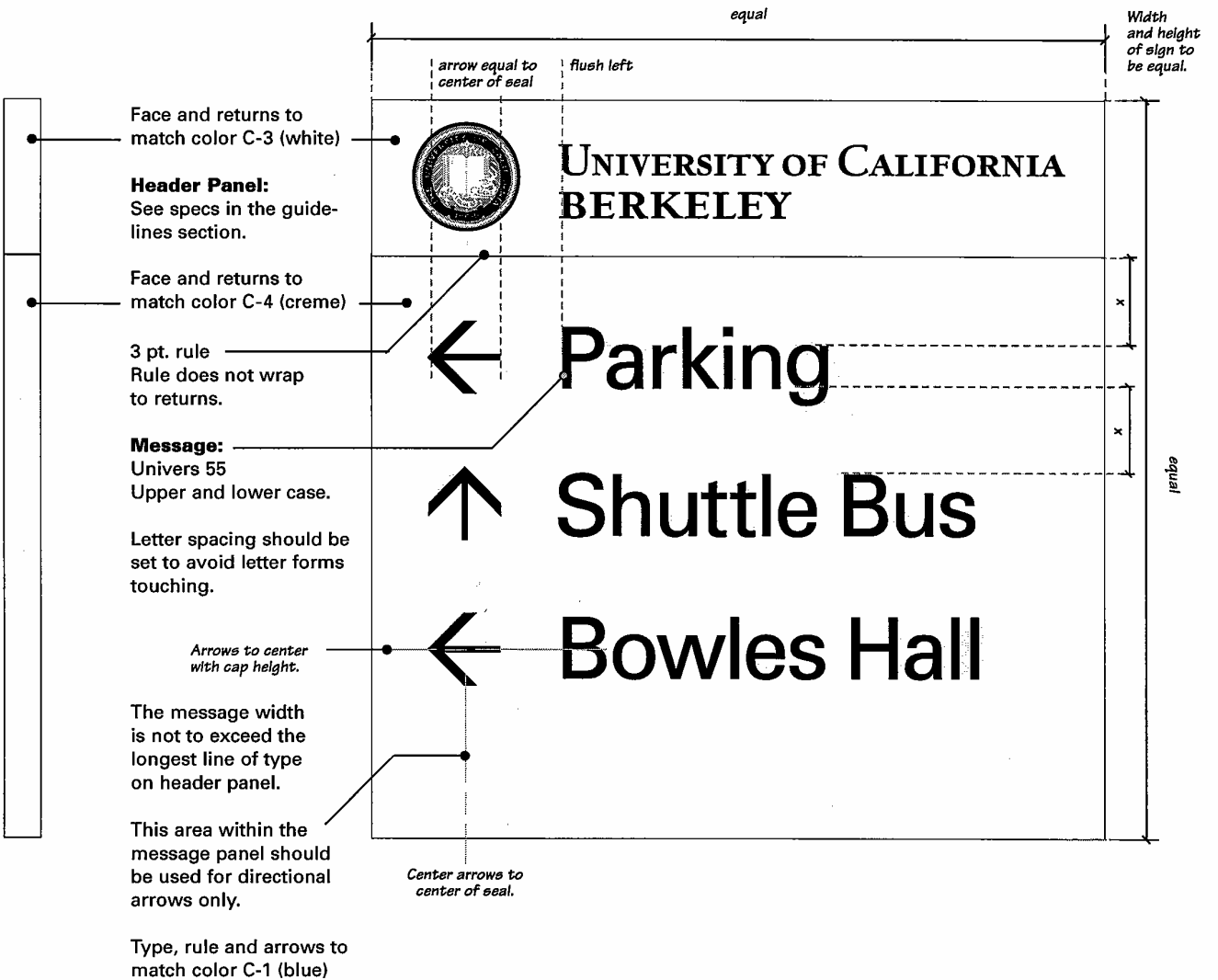

# Sign Types

## Directional D-4

Mock-up of sign type to be reviewed in field to determine final size. Upon approval of a mock-up, select appropriate size square mounting post. See typical mounting details for design intent.

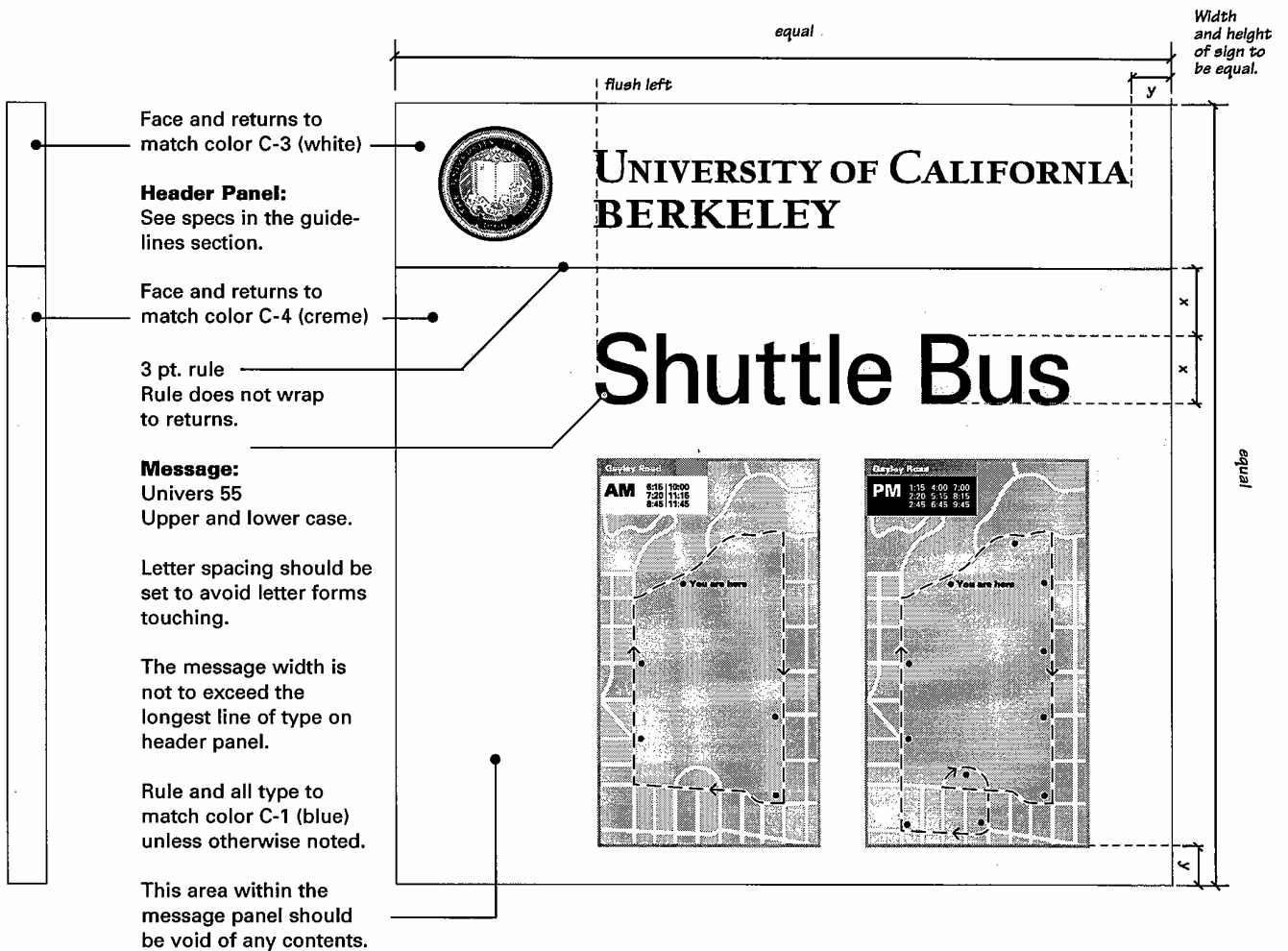

**Map:**  
The intent of the maps is to graphically provide an overview of the bus route, orientation for the new user, and differences in the day and night routes.

The design should be a stylized representation of the campus and the surrounding areas. For further information see cartography in the guidelines section.

- Address of the stop
- Scheduled pick-ups
- Orientation
- Direction
- Stops

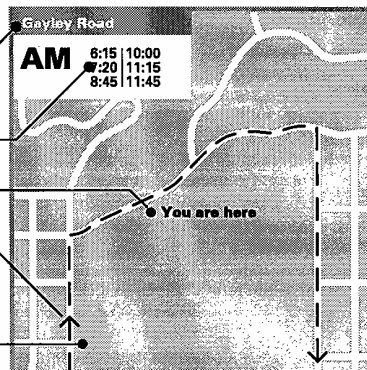

PM schedule is printed white on a dark color.

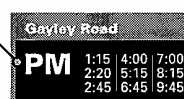

# Sign Types

## Regulatory R-1

Mock-up of sign type to be reviewed in field to determine final size. Upon approval of a mock-up, select appropriate size square mounting post. See typical mounting details for design intent.

Comprehensive specs for this type of sign are covered in the case study section.



**UNIVERSITY OF CALIFORNIA  
BERKELEY**

West Anna Head Lot

**UC Permit  
Required**



**Mon-Fri 7am-5pm**

# Sign Types

## Regulatory R-2 & R-3

Mock-up of sign type to be reviewed in field to determine final size. Upon approval of a mock-up, select appropriate size square mounting post. See typical mounting details for design intent.

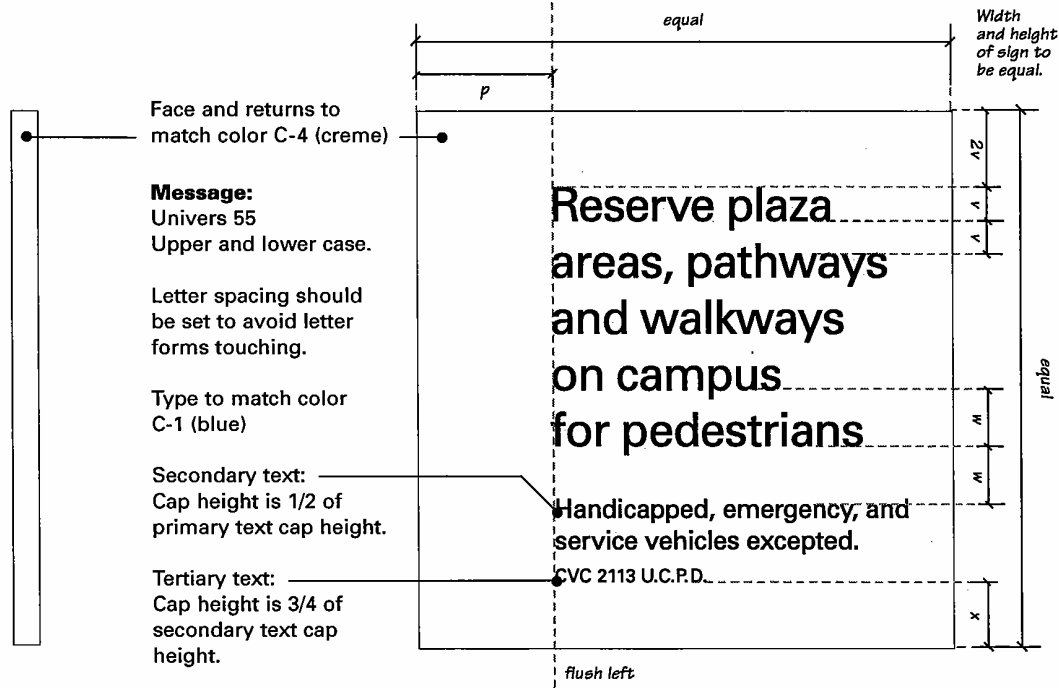
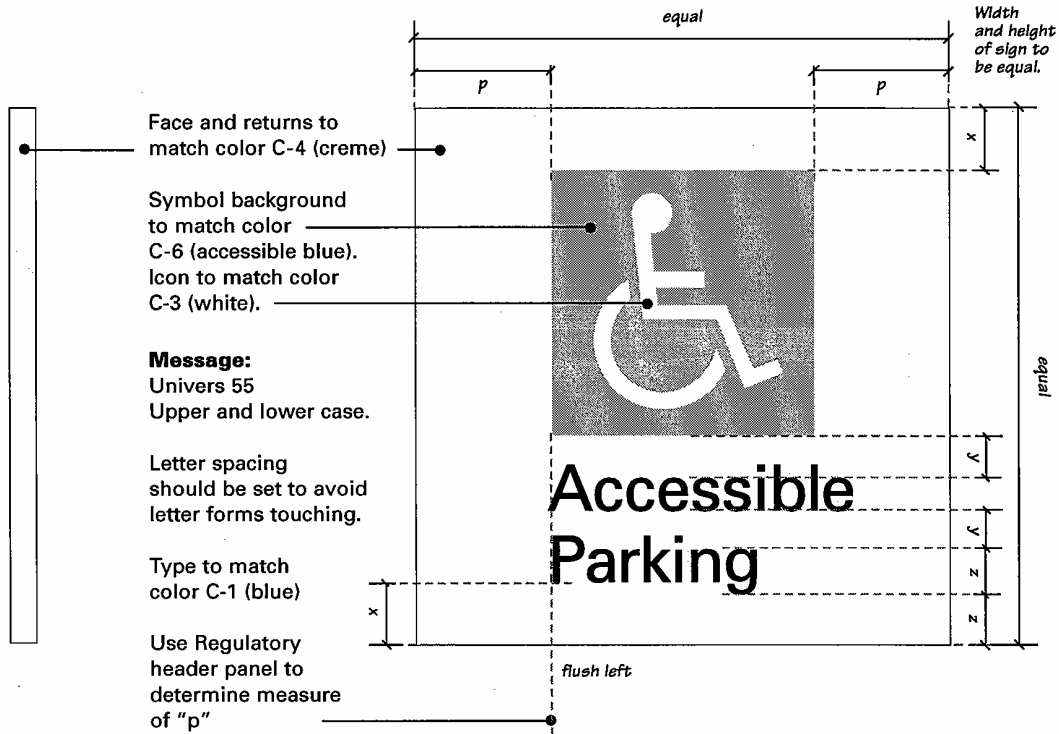



# Case Study

The following pages were taken from the Parking and Transportation Signage Guidelines, released on the 6th of January 1995. It illustrates the implementation of the signage guidelines discussed in the previous section. The category of signage that these represent is called **Regulatory**. Within this case study there are flyers that illustrate how the signage guidelines can have additional applications.

- **Introduction**
- **Regulatory Sign Types A & B**
- **Regulatory Sign Types C  
DMT Machines**
- **Regulatory Sign Types D  
System Machines**
- **Mounting Details**
- **Regulatory Temporary Signage**
- **Regulatory Barricade Signage**
- **Regulatory Flyers**

# Introduction

Skidmore, Owings & Merrill, in collaboration with many different departments at the University, developed the following signage guidelines for the U.C. Berkeley Parking and Transportation offices. The Guidelines address the most prominent and frequently appearing signs on campus.

The majority of this system is the permit and public parking identification signs (Sign Types A and B). These sign types, located at entries to parking structures and lots, are often the first image projected to the public by the University. Currently, these "welcome" signs contain too much information in very complicated layouts.

The proposed signage is simpler in its message, with a clear layout and a fitting image for the University.

One of the most difficult aspects of the system will be to maintain it - in particular, keeping the messages consistent and brief. Wordy signs listing every rule and repeating information are confusing and ultimately self defeating.

By adhering to the parameters and guidelines described in this manual, the sign system will both serve its purpose and reflect well on the University.

Within this Case Study are the following:

## Sign Types A, B, C, and D

Permanently installed signage at parking lot entries and ticket dispensers.

## Temporary Signage

Signage to announce changes, disruptions, or clarification of issues related to parking and transportation

## Flyers for Parking & Transportation

Layouts for flyers that are to be distributed as required for reinforcement of temporary signage.

existing

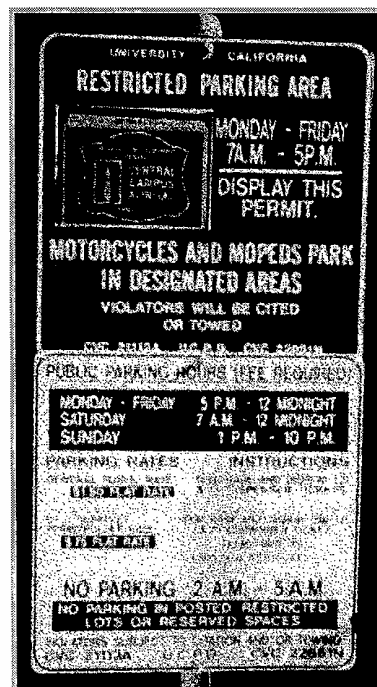

new

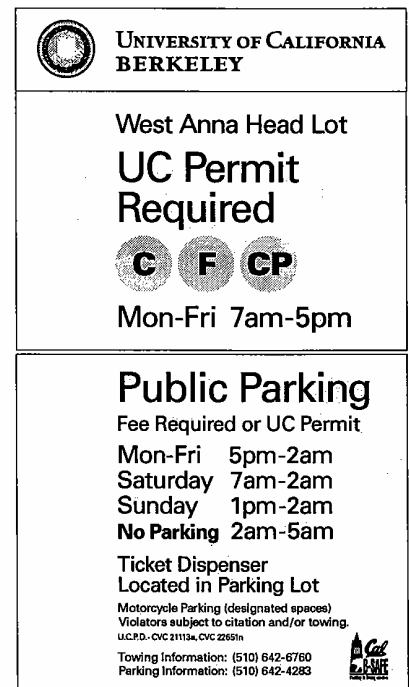

# Sign Types A & B

33" x 29"

## General Notes Sign Types A & B

16 Gauge Porcelain Enamel Face, returns, and back of sign. Minimize radius on all edges and corners.

See Sheet No. G1.08 for Prototypical Mounting Detail.

Fabricator to use sign template created by owner's representative in Adobe Illustrator 5.0-Macintosh for final output of art. Fabricator to modify wording on template as directed by sign schedule.

Seal is separated into three colors C-1, C-2, C-3. See sheet No. G1.07 for detail of seal.

Background color to match color C-3 (white).

Rule to match color C-1 (blue).

All copy to match color C-1 (blue).

### Sign Type A

Circle color to match color C-2 (gold).

Background color to match color C-4 (creme).

### Sign Type B

NOTE: All type and symbols are integral to sign in porcelain enamel except where indicated on the sign schedule provided by owner. Type and symbols not integral to be vinyl die-cut. Color of vinyl die-cuts to visually match colors of porcelain enamel.

Logo color to match C-1 (blue).

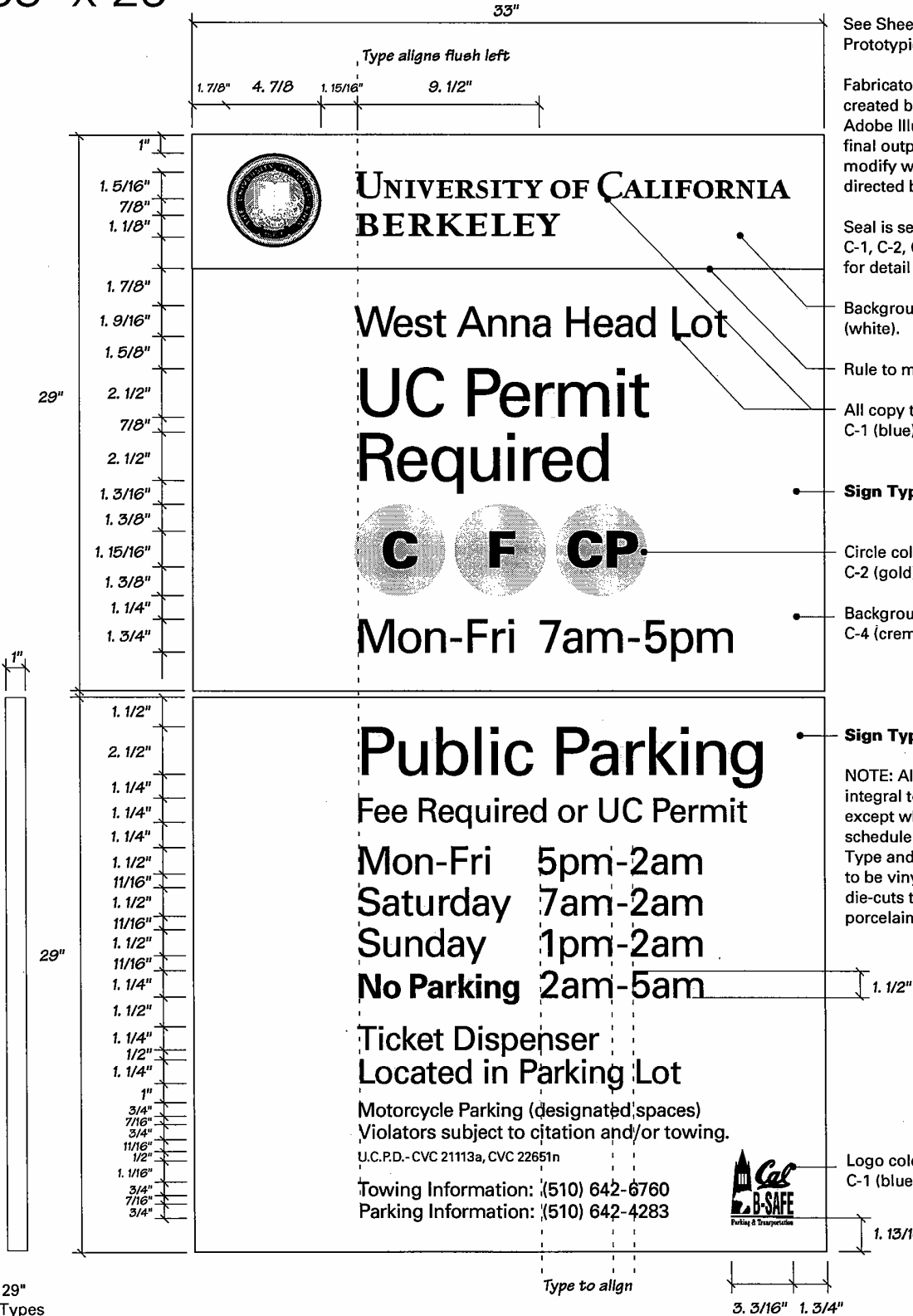

33" x 29"  
Sign Types  
A & B  
return depth  
to equal 1"

Sign Types A & B  
Scale: 1/8" = 1"

Sheet No. G1.00  
Issued for Bid 11/14/94 Skidmore, Owings & Merrill

# Sign Types A & B

See General Notes for Sign Types A & B on sheet No. G1.00

See sheet No.G1.08 for Prototypical Mounting Detail.

33" x 33"

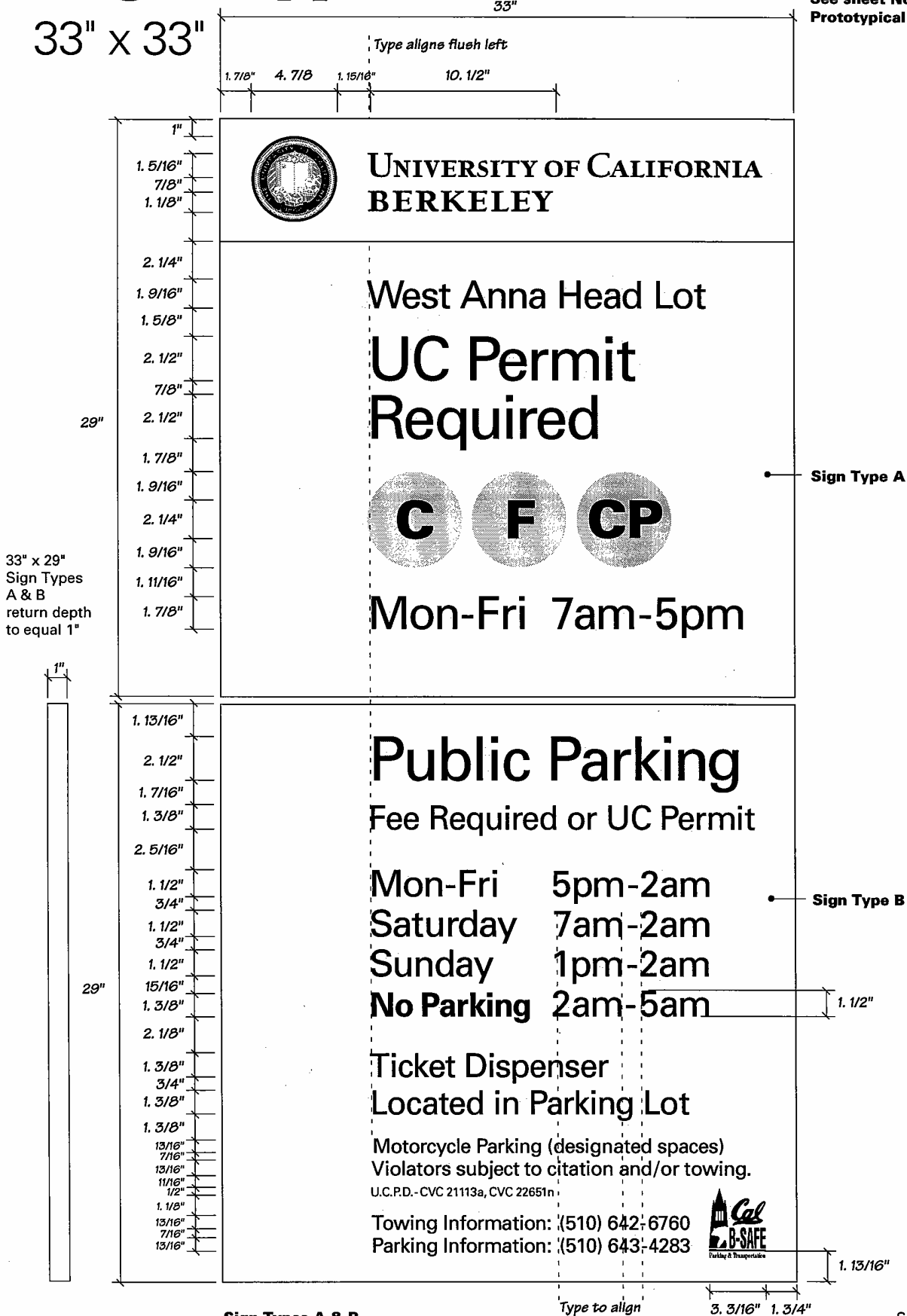

Sign Types A & B  
Scale: 1/8" = 1"

Type to align 3. 3/16" 1. 3/4"

# Sign Types A & B

See General Notes for Sign Types A & B on sheet No. G1.00

See sheet No. G1.08 for Prototypical Mounting Detail.

33" x 33"

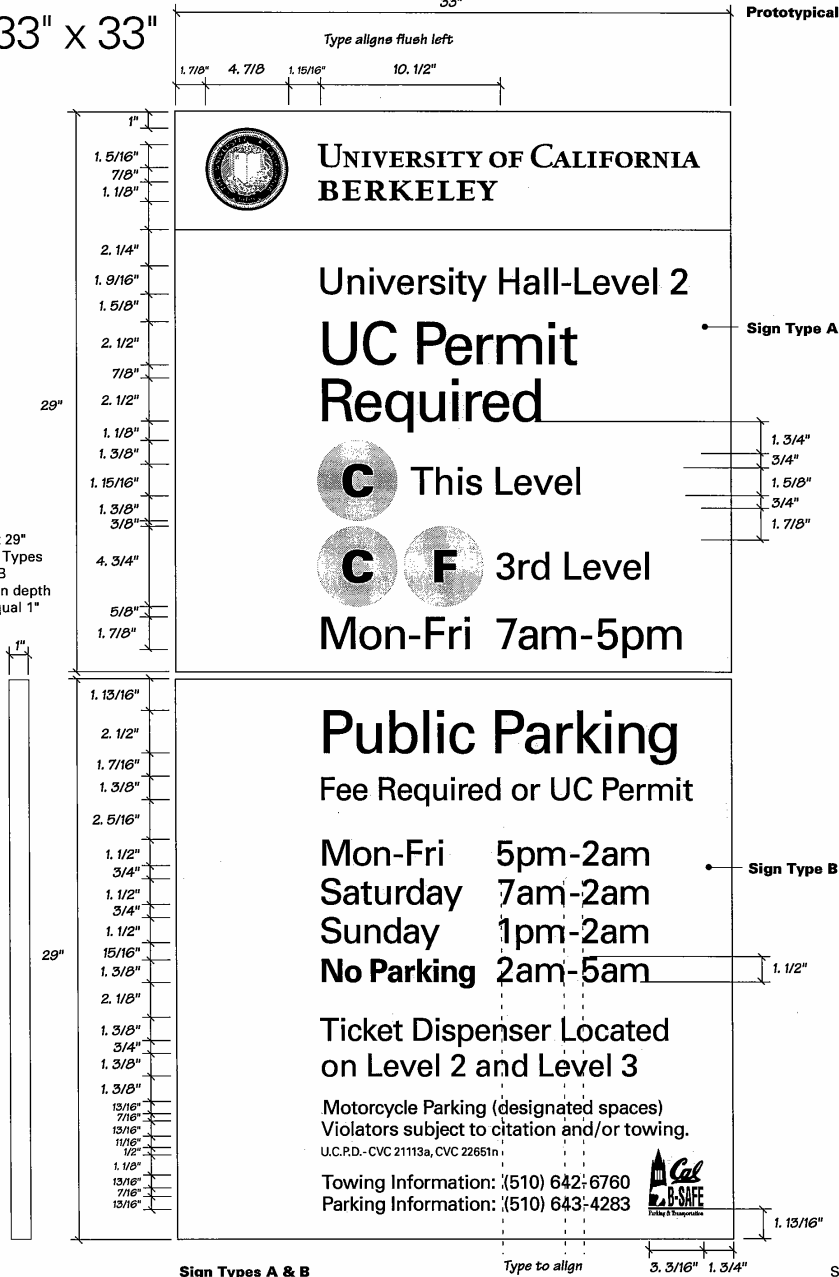

Sign Types A & B  
Scale: 1/8" = 1"

# Sign Type C

## DMT Machines

14" x 14"

### General Notes for Sign Type C

16 Gauge Porcelain Enamel Face, returns, and back of sign. Minimize radius on all edges and corners.

See Sheet No.G1.08 for Prototypical Mounting Detail.

Fabricator to use sign template created by owner's representative in Adobe Illustrator 5.0-Macintosh for final output of art. Fabricator to modify wording on template as directed by sign schedule.

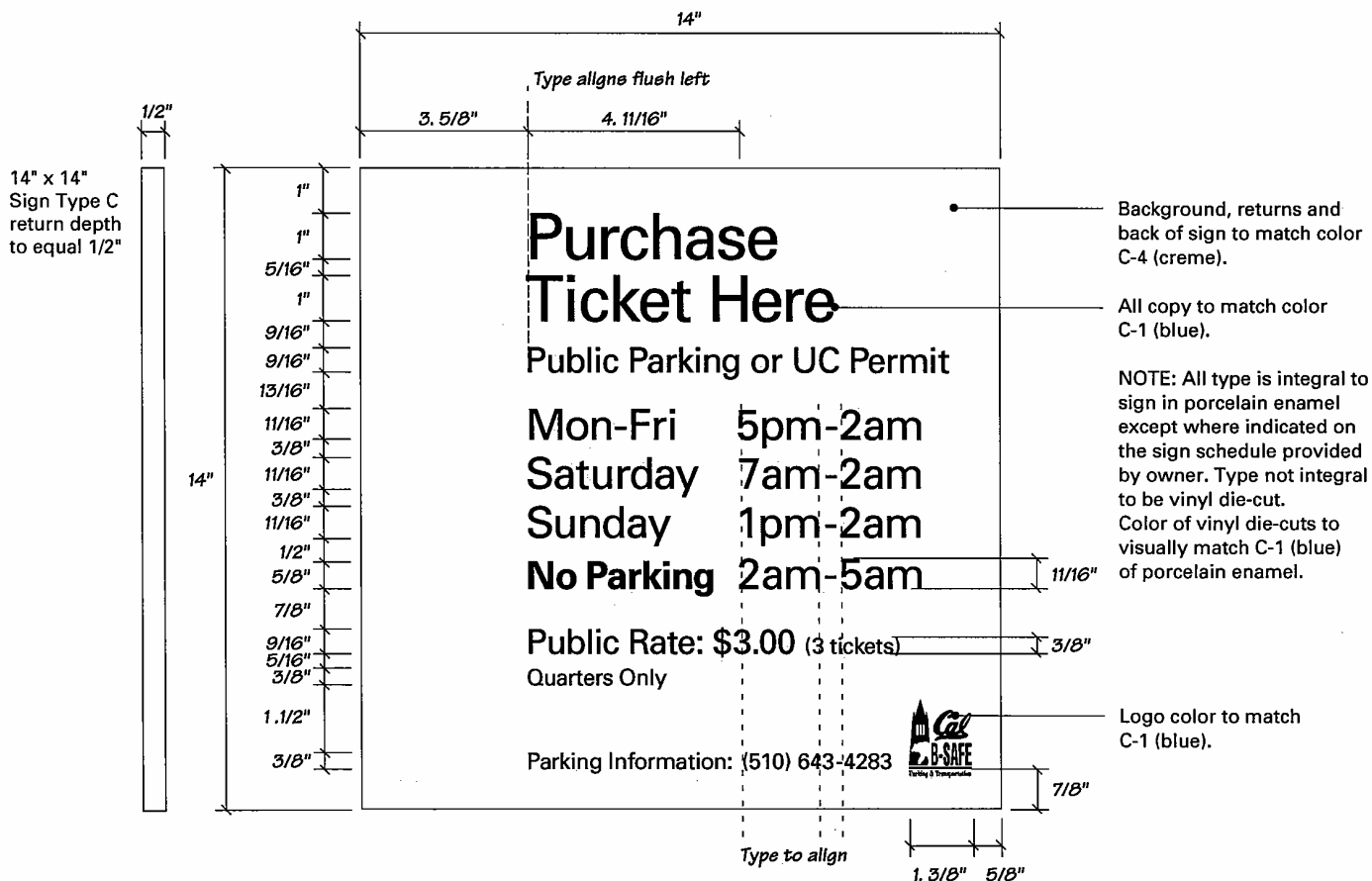

# Sign Type C

## DMT Machines

20" x 20"

See general notes for Sign Type C  
on sheet No. G1.02



# Sign Type C

## DMT Machines

33" x 29"

See general notes for Sign Type C  
on sheet No. G1.02

33" x 29"  
Sign Type C  
return depth  
to equal 1"





# Sign Type D

## System Machines

20" x 20"

See general notes for Sign Type D  
on sheet No. G1.02



# Sign Type D

## System Machines

33" x 29"

See general notes for Sign Type D  
on sheet No. G1.02

33" x 29"  
Sign Type D  
return depth  
to equal 1"



# Mounting Detail

## Prototypical

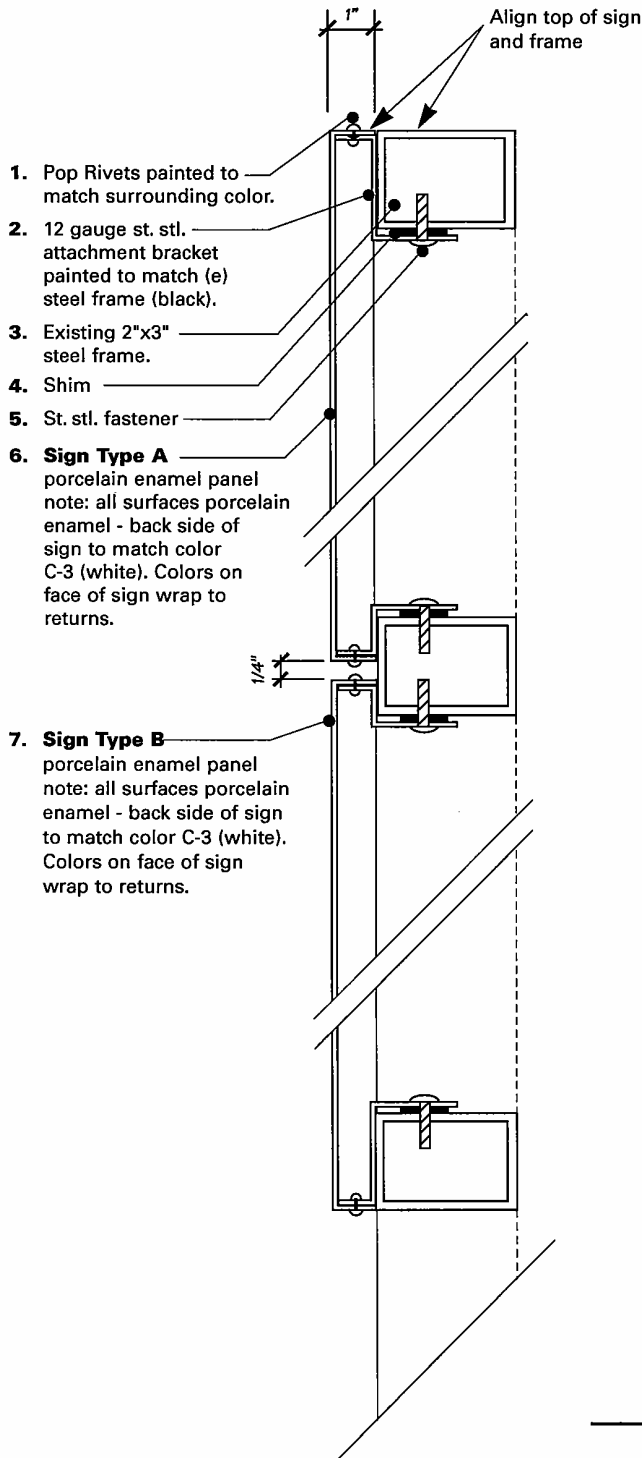

**Sign Types A and B:** The sign panels will be mounted to existing 2"x3" steel frame structures with stainless steel attachment brackets. Pop rivets are to be used to attach the porcelain enamel panels to the brackets. The brackets are to be attached to the existing (e) frame structures by stainless steel fasteners as required.

**Note:** Dimensions of the existing frame structures vary. Fabricator to field verify with U.C. Berkeley representative all dimensions of each frame prior to fabricating and mounting attachment brackets. Brackets to be modified as required. Thoroughly coordinate all mounting and fastening hardware with U.C. Berkeley representative.

Dimensions of the sign panels A and B vary. See sign schedule provided by U.C. Berkeley for final sizes.

**Sign Types C and D:** Mounting conditions vary considerably. Coordinate attachment brackets and mounting hardware with U.C. Berkeley representative. Show all conditions in shop drawings for review by owner's representative.

Dimensions of sign panels C and D vary. See sign schedule provided by U.C. Berkeley.

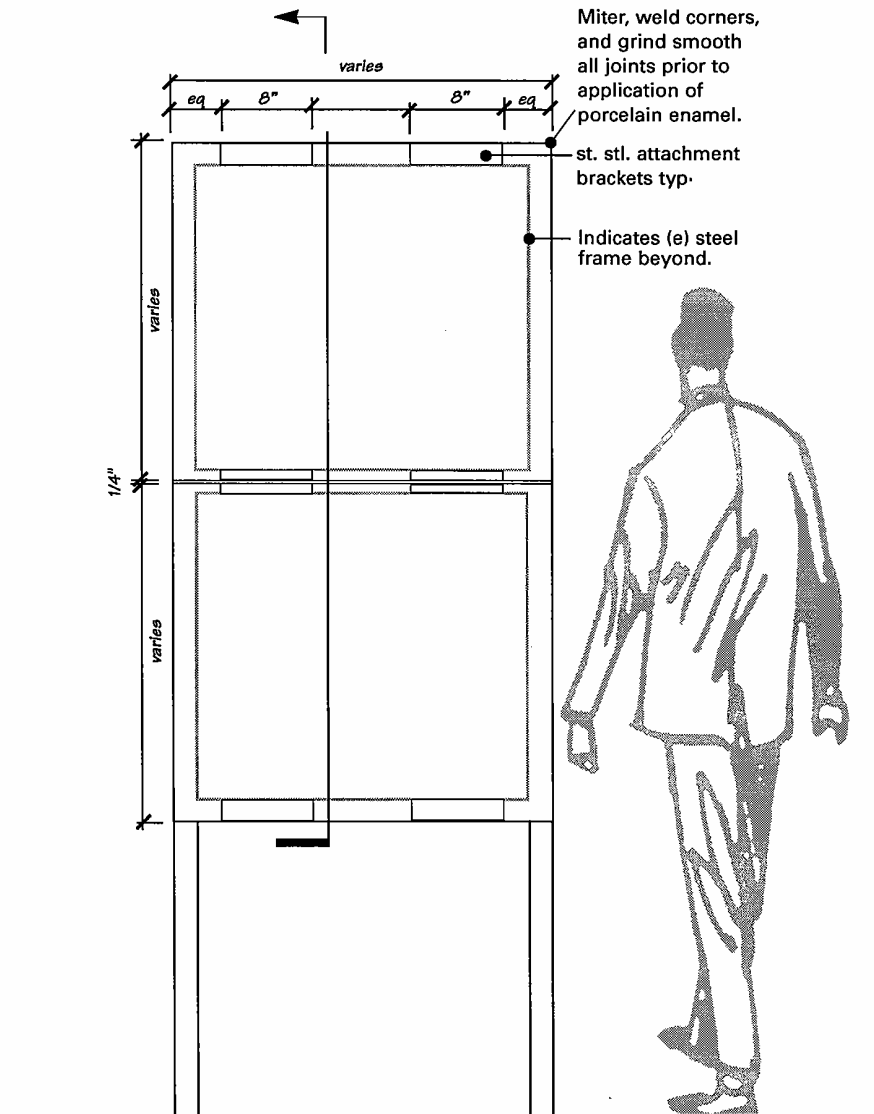

# Mounting Detail

## Alt. Prototypical

**Sign Types A and B:** The sign panels will be mounted to existing 2"x3" steel frame structures with aluminum angles. Weld angles to aluminum panels. Attach angles to the (e) frame structures by stainless steel fasteners as required.

**Note:** Dimensions of the existing frame structures vary. Fabricator to field verify with U.C. Berkeley representative all dimensions of each frame prior to fabricating and mounting aluminum angles. Modify angles as required. Thoroughly coordinate all mounting and fastening hardware with U.C. Berkeley representative.

Dimensions of sign panels A and B vary. See sign schedule provided by U.C. Berkeley for final sizes.

**Sign Types C and D:** Mounting conditions vary considerably. Coordinate attachment and mounting hardware with U.C. Berkeley representative. Show all conditions in shop drawings for review by owner's representative.

Dimensions of sign panels C and D vary. See sign schedule provided by U.C. Berkeley for final sizes.

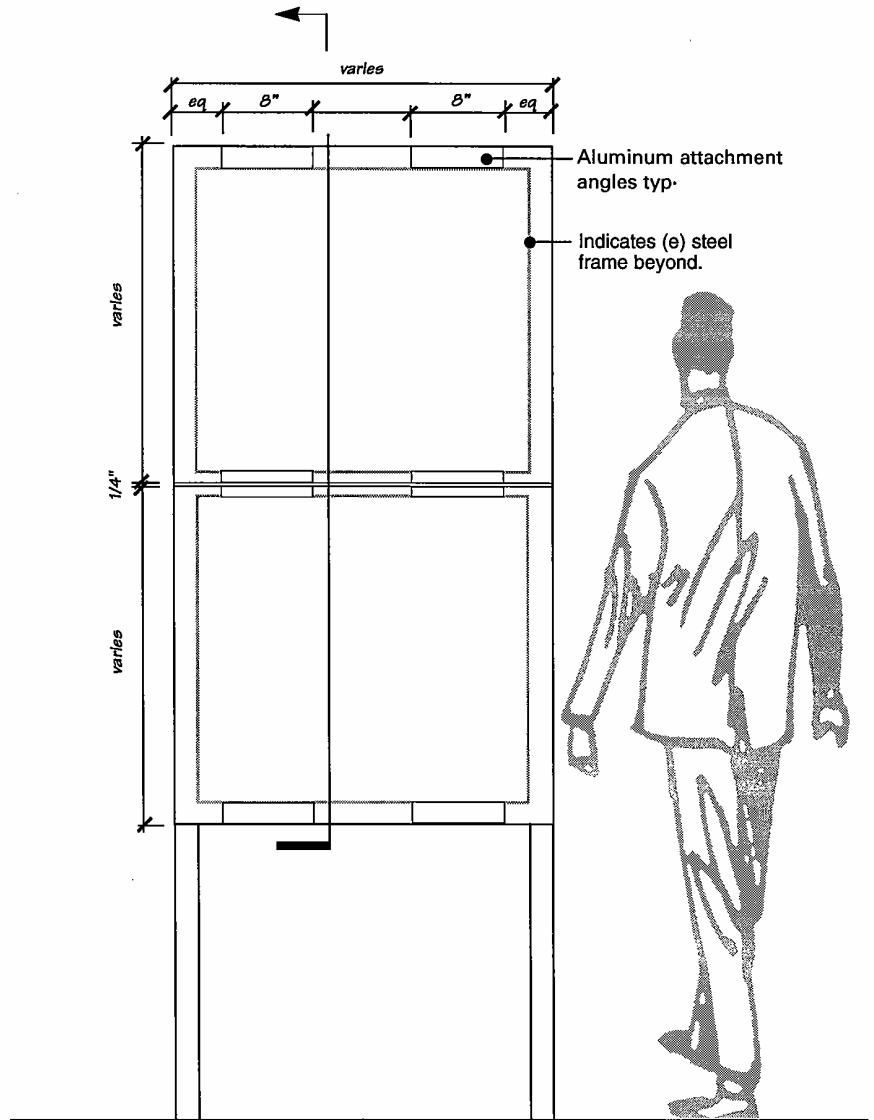
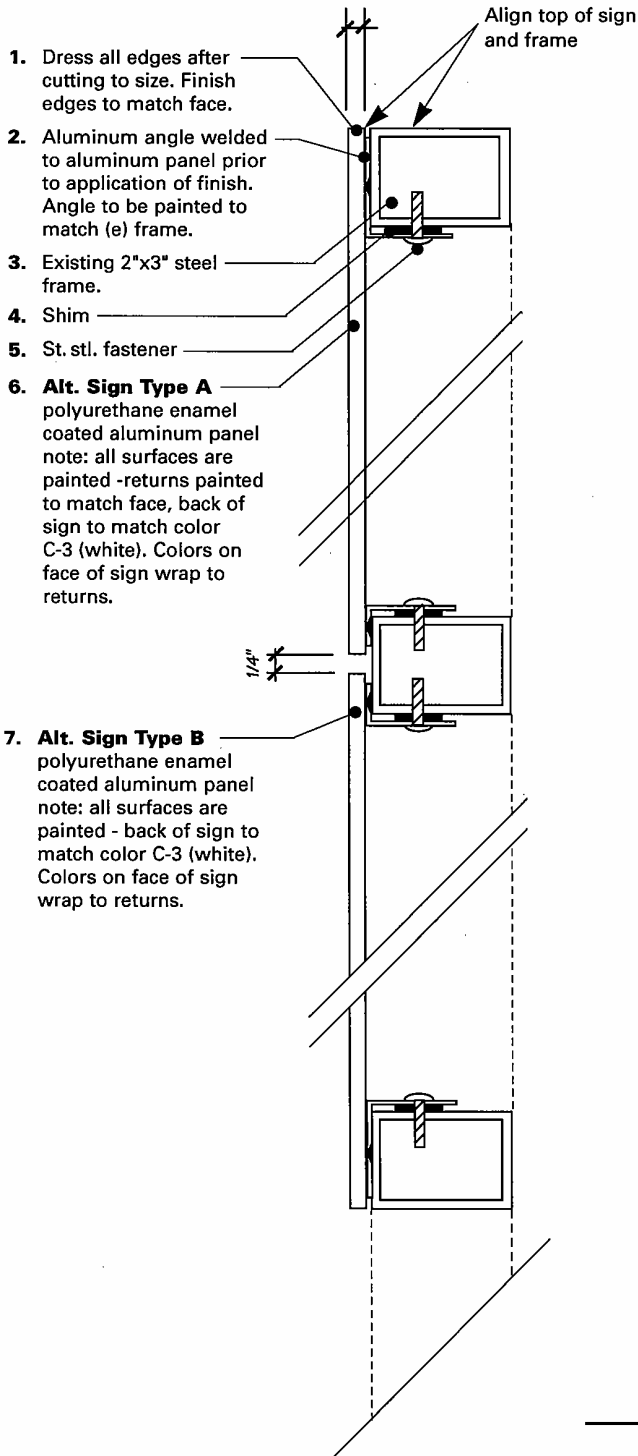

# Temporary Sign 1

## Layout 1

For use on  
33" x 33" (as shown)  
and 33" x 29"

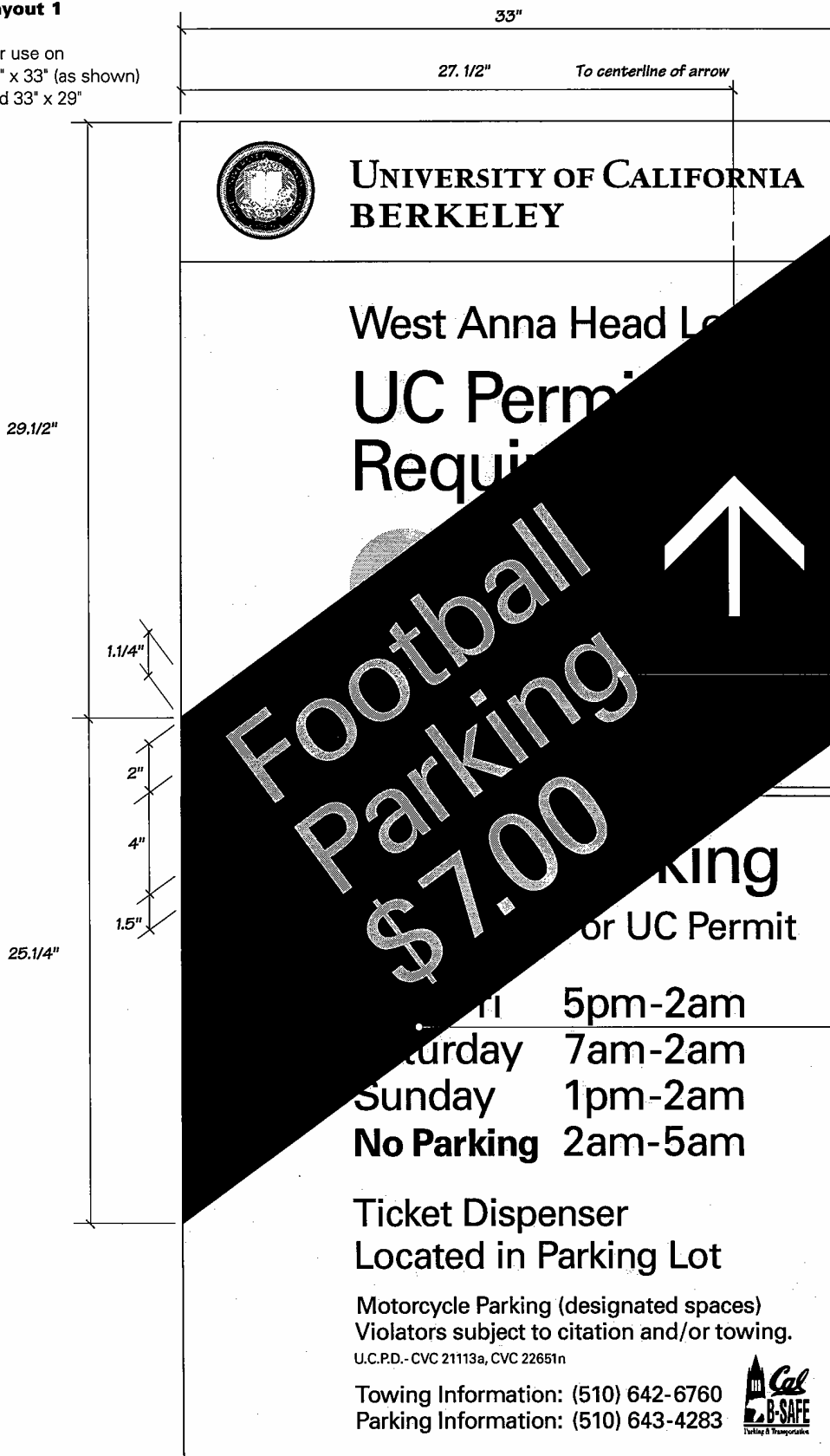

## General Notes Temporary Sign 1

3/16" aluminum plate. Dress all edges, back cut, and over bend to create crisp 90 degree corners. Polyurethane enamel coated aluminum panel. Note all surfaces painted to match face. All type and symbols are to be vinyl die-cut. All colors to visually match colors of porcelain enamel on sign panels beyond.

See Temporary Sign 1 Mounting Detail for specifications.

5.1/4"

12.1/2"

7"

See Arrow Sheet for specifications. Arrow to match color C-3 (white).

Typeface: Univers 55

Size: 4" Cap Height

Letter & word spacing to match sample.

Type color to match C-2 (gold).

Background color to match C-1 (blue).

# Mounting Detail

## Temporary Sign 1

**Temporary Sign 1** will be mounted in front of sign types A and B. Temporary signs are to be attached by stainless steel security screws fastened through pre-punched openings in the returns of the temporary sign and the existing 2"x3" steel frame structures.

Note: Dimensions of the signs and existing frame structures vary. Fabricator to field verify with U.C. Berkeley representative all dimensions prior to fabricating. Temporary signs to be modified as required. Thoroughly coordinate all mounting and fastening hardware with U.C. Berkeley representative.

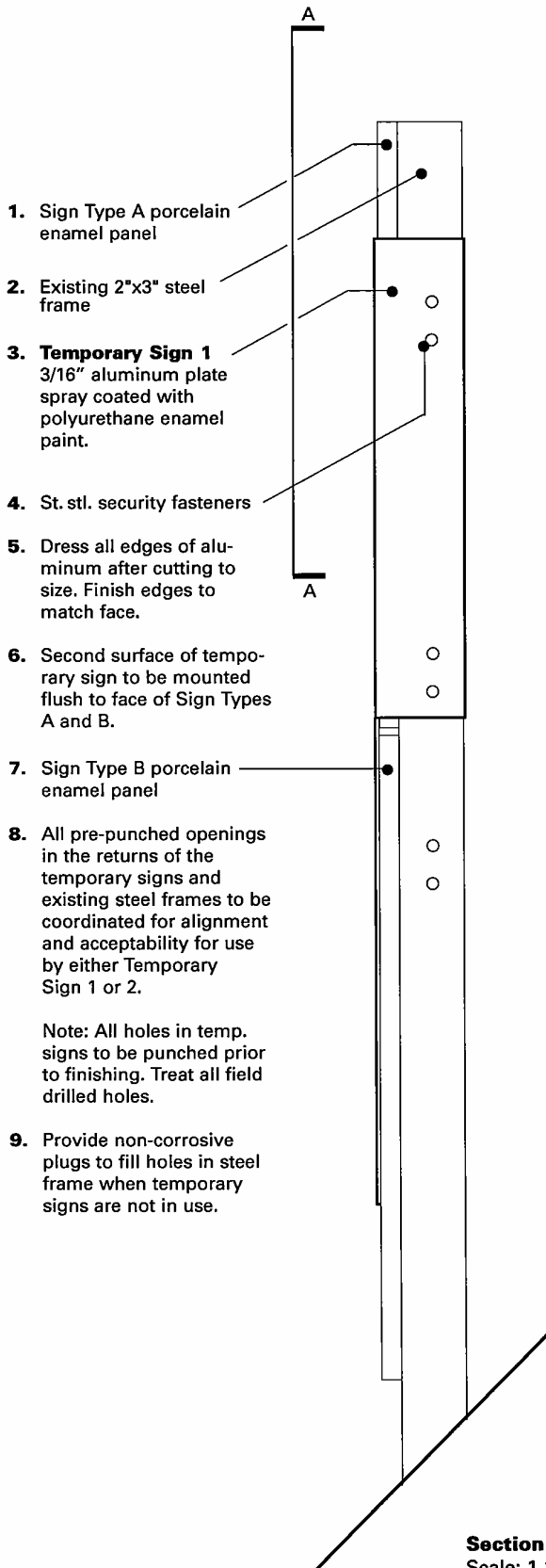

Indicates existing 2" x 3" steel frame beyond

Non-corrosive shim as required

**Section A - A**  
Scale: 3" = 1'-0"

**Section A**  
Scale: 1 1/2" = 1'-0"

**Date: 1/6/95** Skidmore, Owings & Merrill

# Temporary Sign 2

For use on  
33" x 33" (as shown)  
and 33" x 29"

## General Notes Temporary Sign 2

Polyurethane enamel coated aluminum panel. Note all surfaces painted to match face. All type and symbols are to be vinyl die-cut. All colors to visually match colors of porcelain enamel on sign panels beyond.

See Temporary Sign 2 Mounting Detail for specifications.

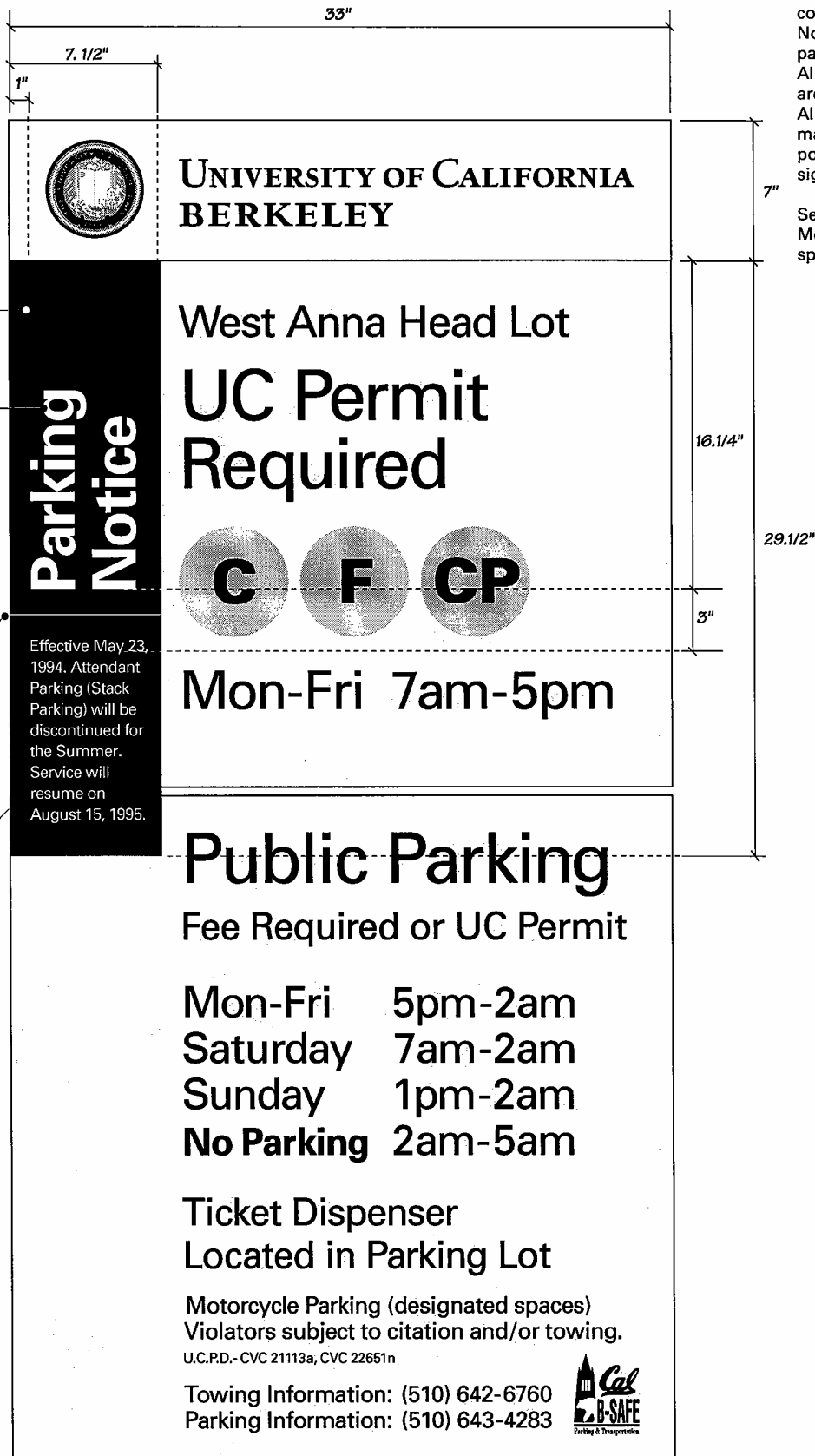

Background color to match C-1 (blue)

Typeface: Univers 65  
Size: 2. 1/4" Cap Height

Letter Spacing to match sample.

Baseline to baseline of type: 3"

Type color to match C-3 (white)

White Rule

Frequently changing messages should be in vinyl type on a low tac vinyl background (color to match C-1, blue)

Typeface: Univers 55

Size: 1/2" Cap Height

Letter Spacing to match sample.

Baseline to baseline of type: 1"

Type color to match C-3 (white)

Temporary Sign 2

Scale: 1/8" = 1"

Date: 1/6/95 Skidmore, Owings & Merrill

# Mounting Detail

## Temporary Sign 2

**Temporary Sign 2** will be mounted in front of sign types A and B. Temporary signs are to be attached by stainless steel security screws fastened through pre-punched openings in the returns of the temporary sign and the existing 2"x3" steel frame structures.

Note: Dimensions of the signs and existing frame structures vary. Fabricator to field verify with U.C. Berkeley representative all dimensions prior to fabricating. Temporary signs to be modified as required. Thoroughly coordinate all mounting and fastening hardware with U.C. Berkeley representative.

1. Sign Type A porcelain enamel panel
2. Existing 2"x3" steel frame
3. **Temporary Sign 2** 3/16" aluminum plate spray coated with polyurethane enamel paint.
4. St. stl. security fasteners
5. Dress all edges of aluminum after cutting to size. Finish edges to match face.
6. Second surface of temporary sign to be flush to face of sign types A and B. Use self adhesive magnetic tape applied to second surface of temporary sign if required.
7. Sign Type B porcelain enamel panel
8. All pre-punched openings in the returns of the temporary signs and existing steel frames are to be coordinated for alignment and acceptability for use by either Temporary Sign 1 or 2.

Note: All holes in temp. signs to be punched prior to finishing. Treat all field drilled holes.

9. Provide non-corrosive plugs to fill holes in steel frame when temporary signs are not in use.

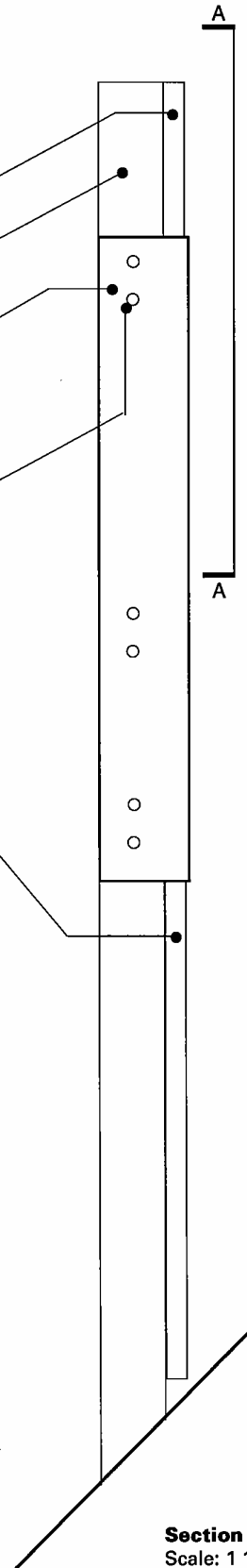

**Section A**  
Scale: 1 1/2" = 1'-0"

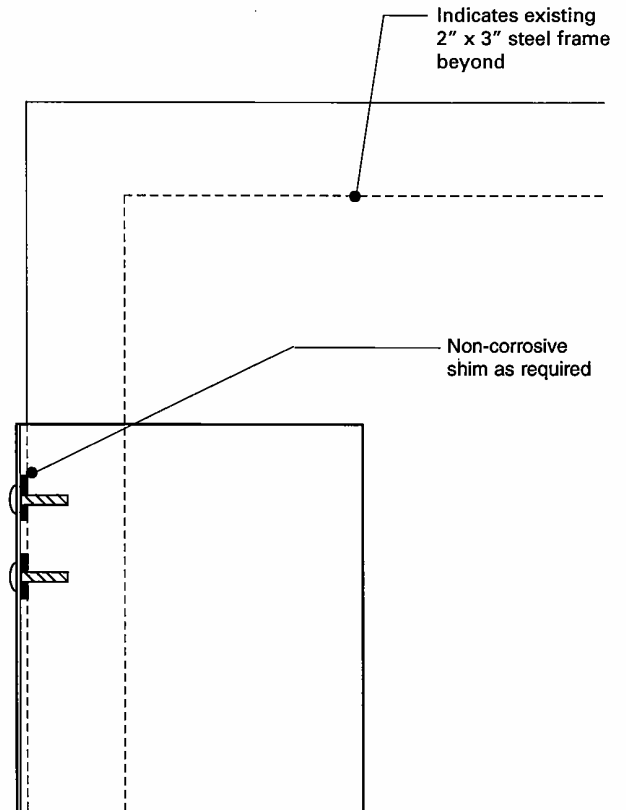

**Section A - A**  
Scale: 3" = 1'-0"



# Barricade Sign

24" x 22"

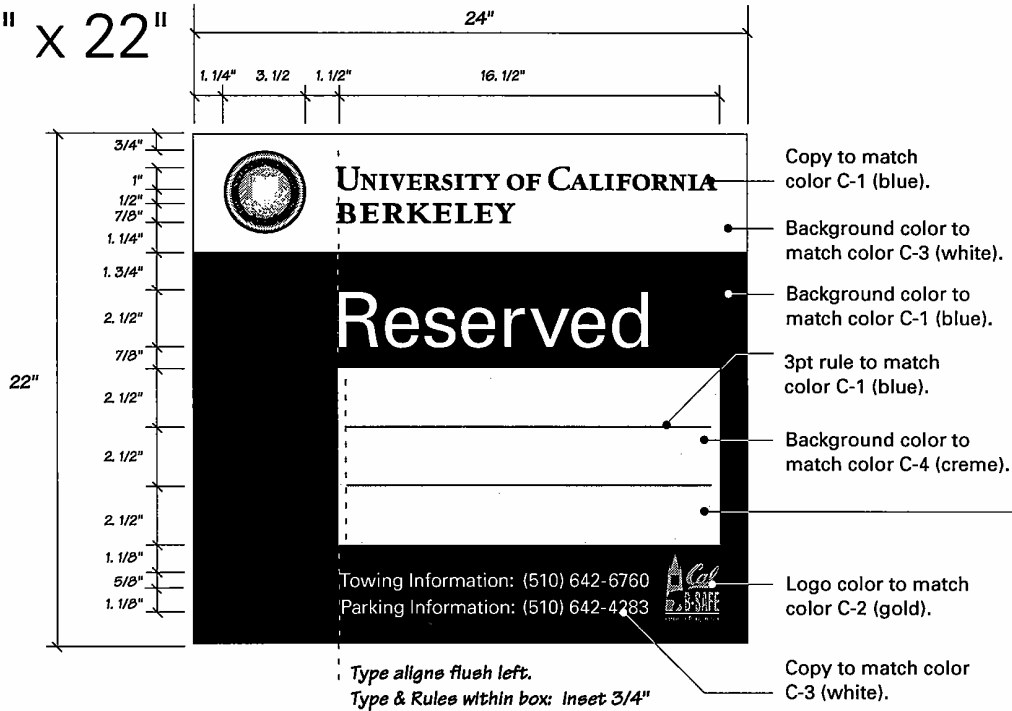

## General Notes Barricade Sign

16 Gauge Porcelain Enamel Face, returns, and back of sign. Minimize radius on all edges and corners. Back of sign to match color C-3 (white). Colors on face of sign wrap to return.

Seal is separated into three colors C-1, C-2, C-3. See sheet No. G1.07 for detail of seal.

NOTE: All type and symbols are integral to sign in porcelain enamel.

Mount sign flush to existing barricade structure as required with no visible fasteners.

Message area may be filled in as required to indicate for whom the lot is reserved, the date, and the time. A typical **black** marker (such as "El Marko" brand) can be used. Windex cleaner with a cloth will remove the message so that it can be used again and again.

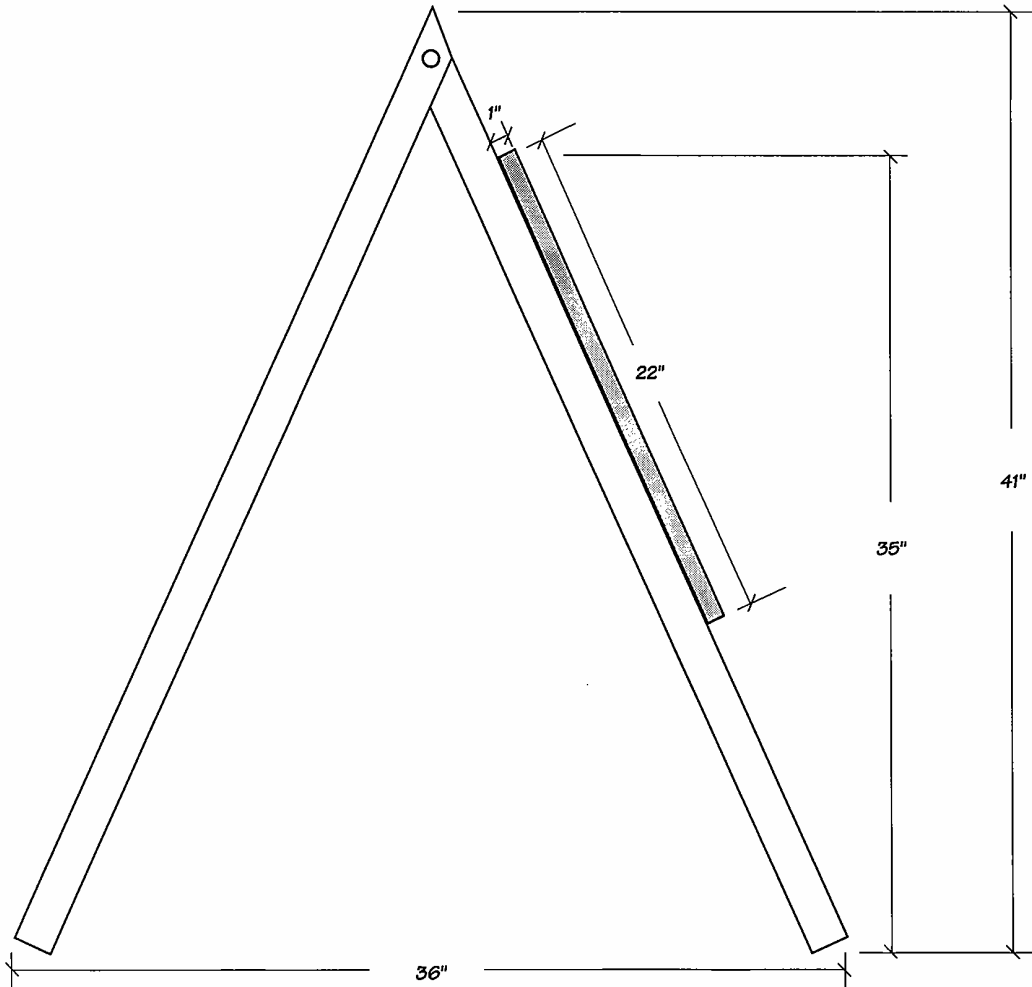

# Temporary Signs



UNIVERSITY OF CALIFORNIA  
BERKELEY

West Anna Head Lot

UC Permit  
Required

Football  
Parking  
\$7.00

←

or UC Permit

5pm-2am  
7am-2am  
1pm-2am  
2am-5am

No Parking

Ticket Dispenser  
Located in Parking Lot

Motorcycle Parking (designated spaces)  
Violators subject to citation and/or towing.  
U.C.P.D. - CVC 21113a, CVC 22651n

Towing Information: (510) 642-6760  
Parking Information: (510) 643-4283





UNIVERSITY OF CALIFORNIA  
BERKELEY

West Anna Head Lot

UC Permit  
Required

Parking  
Notice

C F CP

Mon-Fri 7am-5pm

Public Parking

Fee Required or UC Permit

Mon-Fri 5pm-2am  
Saturday 7am-2am  
Sunday 1pm-2am  
No Parking 2am-5am

Ticket Dispenser  
Located in Parking Lot

Motorcycle Parking (designated spaces)  
Violators subject to citation and/or towing.  
U.C.P.D. - CVC 21113a, CVC 22651n

Towing Information: (510) 642-6760  
Parking Information: (510) 643-4283





UNIVERSITY OF CALIFORNIA  
BERKELEY

Reserved

Towing Information: (510) 642-6760  
Parking Information: (510) 642-4283



# Flyer layout

**Color:** If funds allow, the University Seal and School Identification could be pre-printed in color. Updates would then be xeroxed onto these sheets.

## Full Sheet (8 1/2" x 11")

The relationship between the University Seal and School Identification is the same used in the signage system with the exception of the margins.

The contents have been broken down into the following groups.

1. Subject/Location
2. General Topic
3. Topic Clarification
4. Date/Time Effective
5. Explanation

Helpful key items are highlighted in bold.

6. Authority

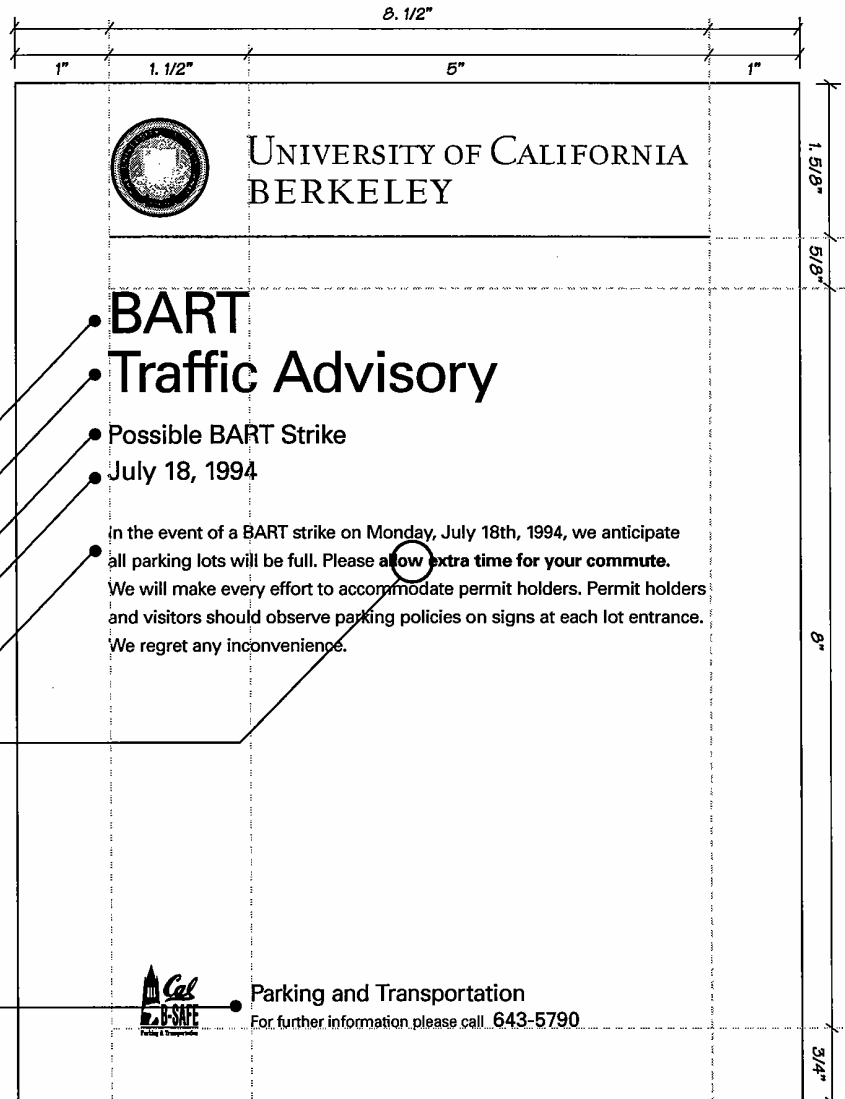

## Half Sheet (8 1/2" x 5 1/2")

The grid structure is the same as above. With the limited amount of space, the content has been grouped into fewer sections.

1. Subject/Location; General Topic
2. Topic Clarification; Date/Time Effective; Explanation
3. Authority

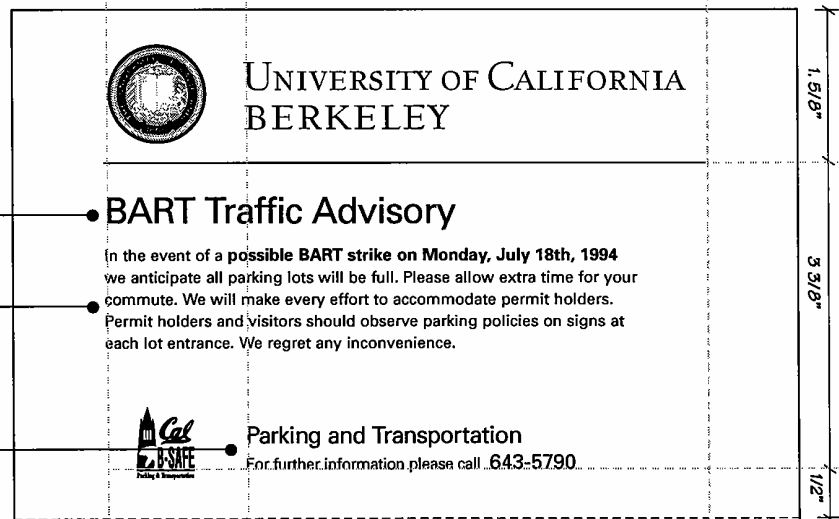

# Flyers

new



UNIVERSITY OF CALIFORNIA  
BERKELEY

---

### BART Traffic Advisory

In the event of a possible BART strike on Monday, July 18th, 1994, we anticipate all parking lots will be full. Please allow extra time for your commute. We will make every effort to accommodate permit holders. Permit holders and visitors should observe parking policies on signs at each lot entrance. We regret any inconvenience.



Parking and Transportation  
For further information please call 643-5790



UNIVERSITY OF CALIFORNIA  
BERKELEY

---

### BART Traffic Advisory

Possible BART Strike  
July 18, 1994

In the event of a BART strike on Monday, July 18th, 1994, we anticipate all parking lots will be full. Please **allow extra time for your commute**. We will make every effort to accommodate permit holders. Permit holders and visitors should observe parking policies on signs at each lot entrance. We regret any inconvenience.



Parking and Transportation  
For further information please call 643-5790

existing



Parking and Transportation

### TRAFFIC ADVISORY

In the event of a BART strike on **Monday, July 18, 1994** we anticipate all parking lots will be full. Please **ALLOW EXTRA TIME FOR YOUR COMMUTE**. We will make every effort to accommodate permit holders. Permit holders and visitors should observe parking policies on signs at each lot entrance. We regret any inconvenience.

For further information please call **643-5790**.





UNIVERSITY OF CALIFORNIA  
BERKELEY

## Bowles Lot Parking Notice

July 1 & 2, 1994  
7am-midnight

The Bowles Lot will be reserved on Friday, July 1st and Saturday, July 2nd, 1994 from 7am - midnight for a special event at the Greek Theatre. We regret any inconvenience.

Alternate parking will be available at:

Kleeberger Lot  
(Stadium Rimway across from Bowles Lot)

Foothill Lot  
(Hearst Avenue east of Highland Avenue)



Parking and Transportation  
For further information please call 643-5790



UNIVERSITY OF CALIFORNIA  
BERKELEY

## Construction Access Interruption

May 4-31, 1994  
7am-5pm

During the time and dates above, construction vehicles will be entering the Girton Hall Road access, southeast of Hildebrand Hall, to remove dirt from the Chemistry 3 Laboratories construction site. This project will continue 2-3 times a week.

Construction vehicles will exit the site through the East Gate, off University Drive. Vehicles will turn left onto Gayley as they exit the East Gate area.

Traffic direction staff will be posted in the areas noted below to minimize traffic delays and maintain exit access for Girton Hall Road.

Flagperson locations:  
Intersection of Gayley and Rimway  
Southeast corner of Hildebrand  
University Drive (East Gate area)



Parking and Transportation  
For further information please call 643-5790

## PARKING NOTICE for Bowles Lot

July 1 - 2, 1994  
7:00 a.m. - 12:00 midnight

The Bowles Lot will be reserved on Friday, July 1 and Saturday, July 2, 1994 from 7:00 a.m. - 12 midnight for a special event at the Greek Theatre.

Alternate parking will be available at:

- ▶ Kleeberger Lot (Stadium Rimway across from Bowles Lot)
- ▶ Foothill Lot (Hearst Avenue east of Highland Avenue)

We regret any inconvenience. Thank you for your cooperation.

Parking & Transportation 642-5401



## Construction Access Interruption May 4 - 31, 1994

Beginning Wednesday, May 4, 1994 construction vehicles will be entering the Girton Hall Road access, southeast of Hildebrand Hall, to remove dirt from the Chemistry 3 Laboratories construction site.

Construction vehicles will exit the site through the East Gate, off University Drive. Vehicles will turn left onto Gayley as they exit the East Gate area.

Traffic direction staff will be posted in the areas noted below to minimize traffic delays and maintain exit access for Girton Hall Road.

Flagperson locations:

- ▶ Intersection of Gayley and Rimway
- ▶ Southeast corner of Hildebrand
- ▶ University Drive (East Gate area)

This project will continue 2-3 times a week through May 31, 1994, between 7:00 a.m. and 5:00 p.m. We apologize for the inconvenience. For additional information contact Parking & Transportation Services at 643-5790.