

LAW ENFORCEMENT STANDARDS PROGRAM

PASSIVE, FIRST GENERATION NIGHT VISION DEVICES

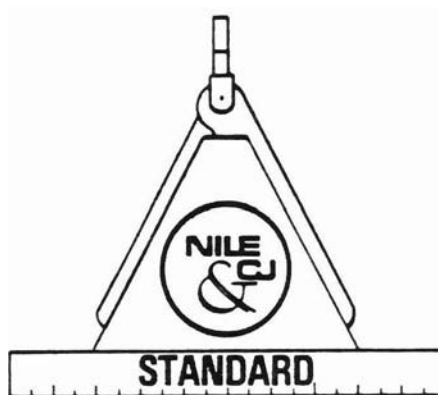

U.S. DEPARTMENT OF JUSTICE
Law Enforcement Assistance Administration
National Institute of Law Enforcement and Criminal Justice

LAW ENFORCEMENT STANDARDS PROGRAM

NILECJ STANDARD

FOR

PASSIVE, FIRST GENERATION NIGHT VISION DEVICES

**A Voluntary National Standard Promulgated by the
National Institute of Law Enforcement and Criminal Justice.**

June 1975

**U.S. DEPARTMENT OF JUSTICE
Law Enforcement Assistance Administration
National Institute of Law Enforcement and Criminal Justice**

**LAW ENFORCEMENT ASSISTANCE
ADMINISTRATION**

Richard W. Velde, Administrator
Charles R. Work, Deputy Administrator

**NATIONAL INSTITUTE OF LAW ENFORCEMENT
AND CRIMINAL JUSTICE**

Gerald M. Caplan, Director

ACKNOWLEDGMENTS

This standard was formulated by the Law Enforcement Standards Laboratory of the National Bureau of Standards under the direction of Lawrence K. Eliason and Marshall A. Isler, Managers, Security Systems Program, and Jacob J. Diamond, Chief of LESL. Technical research was performed by Joseph C. Richmond of the Optical Radiation Section of the NBS Heat Division.

For sale by the Superintendent of Documents, U.S. Government Printing Office
Washington, D.C. 20402-Price 80 cents
Stock Number 027-000-00325-7

NILECJ Standard For Passive, First Generation Night Vision Devices Contents

	Page
Foreword	v
1. Purpose and Scope	1
2. Classification	1
3. Definitions	1
4. Requirements	4
4.1 User Information	4
4.2 Workmanship	4
4.3 Marking	4
4.4 Size and Weight	5
4.5 Objective Lens Mounting	5
4.6 Battery Compartment	5
4.7 Controls	5
4.8 Tripod Socket	5
4.9 Eyepiece	5
4.10 Optical Gain	6
4.11 Optical Gain Stability	6
4.12 Light Equivalent Background	6
4.13 Light Induced Background	6
4.14 Luminance of Output Screen	6
4.15 Luminance Uniformity	6
4.16 Cathode and Screen Quality	6
4.17 Contrast Transfer Function	6
4.18 Viewer Distortion	8
4.19 Flare	8
4.20 Temperature and Humidity	8
4.21 Vibration Resistance	8
5. Test Methods	
5.1 Sampling	8
5.2 Testing Schedule	8
5.3 Test Rooms	8
5.4 Test Equipment	8
5.5 Configuration	11
5.6 Eyepiece Tests	11
5.7 General Test Procedures	12
5.8 Optical Gain Test	12
5.9 Optical Gain Stability Test	13
5.10 Light Equivalent Background Test	14
5.11 Light Induced Background Test	14
5.12 Output Screen Luminance Test	15
5.13 Luminance Uniformity Test	15
5.14 Cathode and Screen Quality Test	16
5.15 Contrast Transfer Function Test	16
5.16 Distortion Test	18
5.17 Flare Test	18
5.18 High and Low Temperature Storage, Operation and Thermal Shock Tests ..	21

	Page
5.19 Humidity Test	21
5.20 Vibration Test	21
Appendix A—Light Source	21
Appendix B—Scanning Device	23
Appendix C—Blackbody Cavity	24
Appendix D—Plane Source Spot	24
Appendix E—Large Size Resolution Chart Pattern Fabrication	24

FOREWORD

Following a Congressional mandate* to develop new and improved techniques, systems, and equipment to strengthen law enforcement and criminal justice, the National Institute of Law Enforcement and Criminal Justice (NILECJ) has established the Law Enforcement Standards Laboratory (LESL) at the National Bureau of Standards. LESL's function is to conduct research that will assist law enforcement and criminal justice agencies in the selection and procurement of quality equipment.

In response to priorities established by NILECJ, LESL is (1) subjecting existing equipment to laboratory testing and evaluation and (2) conducting research leading to the development of several series of documents, including national voluntary equipment standards, user guidelines, state-of-the-art surveys and other reports.

This document, NILECJ-STD-0304.00, Passive, First Generation Night Vision Devices, is a law enforcement equipment standard developed by LESL and approved and issued by NILECJ. Additional standards as well as other documents will be issued under the LESL program in the areas of protective equipment, communications equipment, security systems, weapons, emergency equipment, investigative aids, vehicles and clothing.

This equipment standard is a technical document consisting of performance and other requirements together with a description of test methods. Equipment which can meet these requirements is of superior quality and is suited to the needs of law enforcement agencies. Purchasing agents can use the test methods described in this standard to determine firsthand whether a particular equipment item meets the requirements of the standard, or they may have the tests conducted on their behalf by a qualified testing laboratory. Law enforcement personnel may also reference this standard in purchase documents and require that any equipment offered for purchase meet its requirements and that this compliance be either guaranteed by the vendor or attested to by an independent testing laboratory.

The necessarily technical nature of this NILECJ standard, and its special focus as a procurement aid, make it of limited use to those who seek general guidance concerning passive, first generation night vision devices. The NILECJ Guideline Series is designed to fill that need. We plan to issue guidelines to this as well as other law enforcement equipment as soon as possible, within the constraints of available funding and the overall NILECJ program.

The guideline documents to be issued are highly readable and tutorial in nature in contrast to the standards, which are highly technical, and intended for laboratory use by technical personnel. The guidelines will provide, in non-technical language, information for purchasing agents and other interested persons concerning the capabilities of equipment currently available. They may then select equipment appropriate to the performance required by their agency. Recommendations for the development of particular guidelines should be sent to us.

NILECJ standards are subjected to continuing review. Technical comments and recommended revisions are invited from all interested parties. Suggestions should be addressed to the Program Manager for Standards, National Institute of Law Enforcement and Criminal Justice, Law Enforcement Assistance Administration, U.S. Department of Justice, Washington, D.C. 20531.

Lester D. Shubin
Manager, Standards Program
National Institute of Law
Enforcement and Criminal Justice

*Section 402(b) of the Omnibus Crime Control and Safe Streets Act of 1968, as amended.

NILECJ STANDARD
for
PASSIVE, FIRST GENERATION NIGHT VISION DEVICES

1. PURPOSE AND SCOPE

The purpose of this document is to establish performance requirements and methods of test for passive night vision devices used for law enforcement. It applies to first generation devices, which employ three-stage electrostatically focused image intensifier tubes having a maximum effective diameter of 25mm and which operate at night in the absence of operator supplied artificial illumination.

2. CLASSIFICATION

For the purposes of this standard, passive night vision devices are classified into two classes on the basis of optical gain.

2.1 Class A

Passive night vision devices designed for use where the ambient illumination is less than 0.005 lumens per square meter.

2.2 Class B

Passive night vision devices designed for use where the ambient illumination is at least 0.005 lumens per square meter.

3. DEFINITIONS

3.1 Automatic Brightness Control

A control circuit in the electronic power supply of a night vision device that limits the current in the electron beam of the image intensifier tube to a preset value by varying the voltage across the tube. This limits the optical gain and brightness of the output screen when viewing bright objects, protecting the intensifier tube from damage if accidentally turned on in a bright environment or if suddenly subjected to bright lights during use.

3.2 Contrast Transfer Function

The ratio of the modulation contrast in the image of a square wave pattern to that in the pattern. Sometimes called square wave modulation transfer function.

3.3 Critical Focus

The focal position at which a lens or an optical system gives the sharpest image under a given set of conditions.

3.4 Distortion

Failure of an image to truly represent the shape of the object imaged, due to variation in magnification over the field of view.

3.5 Field Emission

An extraneous emission which appears as bright spots or patterns that flicker or appear intermittently in one general position on the phosphor screen of a night vision device. It is voltage dependent, and appears when there is no illumination on the photocathode.

3.6 Flare

Ghost images on the output screen of a night vision device produced by light from a bright source striking the outer surface of the objective lens, specularly reflected from the lens elements,

diaphragm or barrel to form definite patterns in the image. The bright source causing flare may be inside or outside the field of view.

3.7 Group Number

The large numbers that designate the groups of resolution patterns in the Air Force 1951 resolution test chart (see figure 1).

3.8 Ion Spot

A bright diffuse area or spot near the center of the field of a night vision device. It increases in luminance as the photocathode illumination is increased, but may be swamped out at high photocathode illumination.

3.9 Light Equivalent Background

The luminance of a night vision device output screen when no light is incident on the input photocathode. This luminance is evaluated in terms of the irradiance on the photocathode required to produce an equivalent luminance in the absence of background. It is a measure of the dark current of the image intensifier tube.

3.10 Light Induced Background

The non-image-forming, more-or-less uniform background light from the surface of the output phosphor screen of a night vision device that is produced by light on the objective lens.

3.11 Luminance

Photometric brightness. The visual brightness of a surface, expressed as the luminous flux leaving the surface in a given direction per unit solid angle and per unit area projected normal to the given direction. The SI unit is the candela per square meter (cd/m^2).

3.12 Modulation Contrast

For a periodic pattern of a given spatial frequency, in which some optical property such as luminance, illumination, radiance, irradiance, transmittance or reflectance varies periodically, the ratio of the difference between the maximum and minimum values of the property to their sum.

3.13 Modulation Transfer Function

A measure of the image quality of an imaging system or any part thereof, such as a lens, film, TV camera, etc., usually plotted as a function of the spatial frequency in the image. At any one spatial frequency, it is the ratio of the modulation contrast in the image to that in the object imaged, when the object luminance varies sinusoidally in one dimension.

3.14 Optical Gain

The ratio of the luminance of the output screen of a night vision device to the luminance of the source, when viewing a large area uniform diffuse source having the spectral distribution of CIE standard source A.¹

3.15 Optical Transfer Function

The spatial frequency response of an optical system. It consists of two parameters: one describes the variation of modulation with spatial frequency, and the other describes the phase shift (in the image) associated with that frequency. It is the Fourier transform of the line spread function.

3.16 Pattern Number

The number designating an individual pattern in a group in the Air Force 1951 resolution test chart. A pattern consists of two elements, each consisting of three lines and two spaces, one with

¹ The spectral distribution of CIE Standard Source A is given in ASTM Standard Recommended Practice for Spectrophotometry and Description of color in CIE 1931 System, E 308-66. The spectral distribution of Source A is indistinguishable from that of a blackbody at 2856K on the 1968 International Practical Temperature Scale, over the range of 350 to 1000 nm.

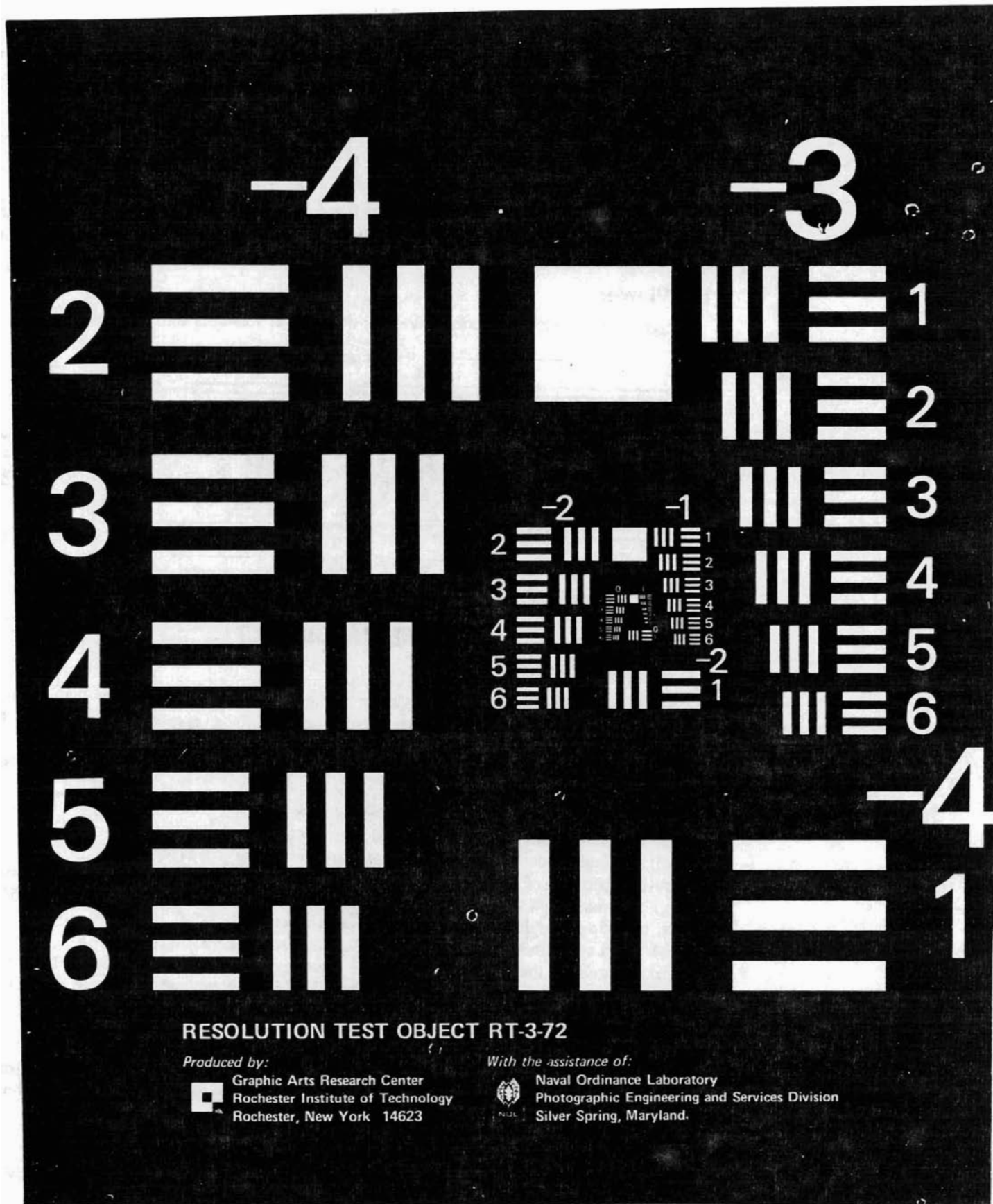

RESOLUTION TEST OBJECT RT-3-72

Produced by:

 Graphic Arts Research Center
Rochester Institute of Technology
Rochester, New York 14623

With the assistance of:

 Naval Ordnance Laboratory
Photographic Engineering and Services Division
Silver Spring, Maryland.

FIGURE 1. Resolution test chart for contrast transfer function test.

the lines vertical and the other with the lines horizontal. The spatial frequency, f , in line pairs per millimeter, of any pattern can be computed from the group number, G (any integer or zero), and pattern number, P (a positive integer from 1 to 6), as

$$f = 2 \frac{[G + (P - 1)/6]}{1}$$

3.17 Relay Lens

A photographic lens designed for use at short viewing distances, where the magnification is near unity. A relay lens is used to photograph the image on the output screen of a night vision device.

3.18 Viewer

A night vision device. A sectional drawing of a typical viewer is shown in figure 2.

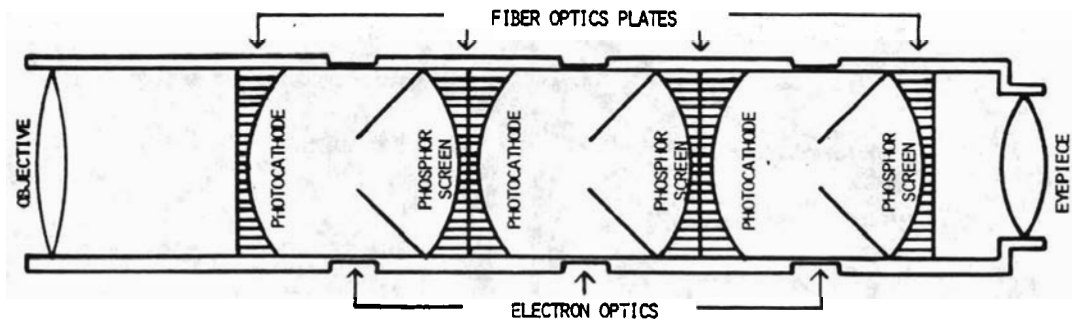

FIGURE 2. Schematic sectional drawing of passive night vision device.

4. REQUIREMENTS

4.1 User Information

The information supplied with the viewer by the manufacturer or distributor shall include:

- (a) Complete operating instructions, including details on eyepiece and objective lens focusing.
- (b) The focal length (in mm) and the f-number of the objective lens, and the T-number if available.
- (c) The magnification factor of the eyepiece lens.
- (d) Complete details on the thread used for mounting the eyepiece lens.
- (e) A complete identification or description of the objective lens mount.
- (f) Identification of the battery required and a source of supply including catalog number.
- (g) Information on the use of a camera to photograph the image on the output screen of the viewer, including relay lens, and the camera mount if required.
- (h) A list of additional objective lenses available from the manufacturer.
- (i) A statement that commonly available photographic lenses can or cannot be used as objective lenses. A source of supply and catalog number for any required adaptor, or an engineering drawing, shall be furnished.

4.2 Workmanship

Workmanship shall be first class in every respect. All threads shall fit smoothly and firmly, with essentially no play. All exterior surfaces shall have a non-glossy finish. All surfaces normally handled during use shall have a non-slip finish.

4.3 Marking

The night vision device shall be permanently and legibly labeled with the manufacturer's name, trade name of the device, if any, and model and serial numbers.

4.4 Size and Weight

The viewer, complete with monocular eyepiece, normal objective lens (focal length not over 80 mm), and a pistol grip if used, shall not exceed 36 cm (14-1/8 in) in length, and its weight shall not exceed 2.5 kg (5.5 lb).

4.5 Objective Lens Mounting

The objective lens mounting shall permit easy and rapid changing of lenses. The mount shall hold the lens in a fixed and reproducible position relative to the input photocathode of the night vision device, and shall lock in place preventing lens removal without intentional release. The focusing shall be smooth and positive. The full focal range from the nearest focal point to infinity shall be covered by no more than one complete revolution of the lens barrel, focusing knob, or focusing lever. The infinity stop shall be placed slightly beyond infinity (providing discernible defocusing) and allowing movement beyond and return to the position of sharpest focus when focusing on distant objects.

4.6 Battery Compartment

The battery compartment shall be clearly marked on the outside, or inside cover, with the type, voltage, and identifying number of the battery or batteries required. The proper polarity for inserting or connecting the batteries shall be clearly marked. If the device can be damaged by insertion of batteries in reverse polarity, the contacts shall be of such design that electrical contact is not made if batteries are inserted with reverse polarity.

4.7 Controls

All switches and control settings shall be identified as to function by clear markings that are visible in dim light. The power switch shall be provided with a guard to minimize the possibility of the switch being turned on accidentally.

4.8 Tripod Socket

The night vision device shall be equipped with one or more metal tripod sockets (1/4—20 thread) in conformance with USASI Standard PH 3.6—1952, Reaffirmed 1963.² Threaded plastic is unacceptable. The depth of the threaded portion of the hole shall be not less than 5 mm (0.2 in) when fabricated of brass or steel, and not less than 7.5 mm (0.3 in) when fabricated of aluminum or other soft metal. The axis of the tripod socket(s) shall be normal to the optical axis of the viewer and lie in the vertical plane through it. There shall be a socket located so that its axis passes near the center of gravity of the viewer for any combination of objective lens, eyepiece, and camera and adaptor. When tested in accordance with paragraph 5.5, the torque required to maintain the viewer in a horizontal plane shall not exceed 1.10 newton meter (9.7 lbf-in).

Accessories (lens, eyepiece, or camera with adaptor) shall be supplied with a combination support/mounting plate if the torque required to maintain the resulting assembly in a horizontal plane exceeds 1.10 newton meter (9.7 lbf-in). The support/mounting plate shall have one or more tripod sockets meeting all requirements of this paragraph.

4.9 Eyepiece

4.9.1 Radiation

When measured in accordance with paragraph 5.6.1, the eyepiece radiation count shall not exceed twice the background radiation count.

4.9.2 Focus Adjustment

When tested in accordance with paragraph 5.6.2, the eyepiece focus shall be adjustable over a range of at least 8 diopters, have a minimum positive adjustment of 2.0 diopters and a minimum

² Available from the American National Standards Institute, 1430 Broadway, New York, New York 10018.

negative adjustment of 4.0 diopters, and the adjusting torque shall not exceed 0.80 newton meter (7.1 lbf-in).

4.9.3 Curvature of Field

When measured in accordance with paragraph 5.6.3, the curvature of field of the eyepiece lens shall be not more than one half of its depth of focus, when focused at infinity.

4.9.4 Distortion

When tested in accordance with paragraph 5.6.4, the eyepiece lens shall have zero positive distortion and not more than 10 percent negative distortion.

4.10 Optical Gain

When measured in accordance with paragraph 5.8, the optical gain of a Class A night vision device shall be 10,000 or more, and the optical gain of a Class B device shall be 1,000 or more.

4.11 Optical Gain Stability

When evaluated in accordance with paragraph 5.9, the optical gain shall not change by more than 5 percent per hour.

4.12 Light Equivalent Background

When evaluated in accordance with paragraph 5.10, the light equivalent background shall not exceed 1×10^{-6} cd/m².

4.13 Light Induced Background

When evaluated in accordance with paragraph 5.11, the light induced background shall not exceed 0.08 for a Class A viewer or 0.10 for a Class B viewer.

4.14 Luminance of Output Screen

When measured in accordance with paragraph 5.12, the luminance of the output screen shall not exceed 2500 cd/m². There shall be provision for limiting the luminance of the output screen to 500 cd/m², for use under dark adapted conditions. A red filter may be used for this purpose.

4.15 Luminance Uniformity

When measured in accordance with paragraph 5.13, the luminance of the output screen shall not fall outside the tolerance limits shown in figure 3, over the circular area centered on the optic axis of the screen having a diameter of 80 percent of that of the output screen.

4.16 Cathode and Screen Quality

When the output face of the screen is examined in accordance with paragraph 5.14, with the objective lens capped, it shall show no ion spots, field emission, leakage, or faceplate breakdown. When the device is viewing a source of uniform luminance, the light and dark spots with contrast greater than ± 30 percent relative to the surrounding area shall not exceed the numbers listed in table 1 for 18 mm diameter tubes, or in table 2 for 25 mm diameter tubes. There shall be no obvious dark boundaries between fiber optics bundles.

4.17 Contrast Transfer Function

When evaluated in accordance with paragraph 5.15, the contrast transfer functions at the respective spatial frequencies shall be not less than the values given below. Modulation transfer functions (MTF) may be used instead of contrast transfer functions (CTF).

Spatial Frequency (Line Pairs per mm)	CTF (MTF)	CTF (MTF)
	Class A	Class B
2.5	0.90	0.88
7.5	0.58	0.55
16.0	0.18	0.15

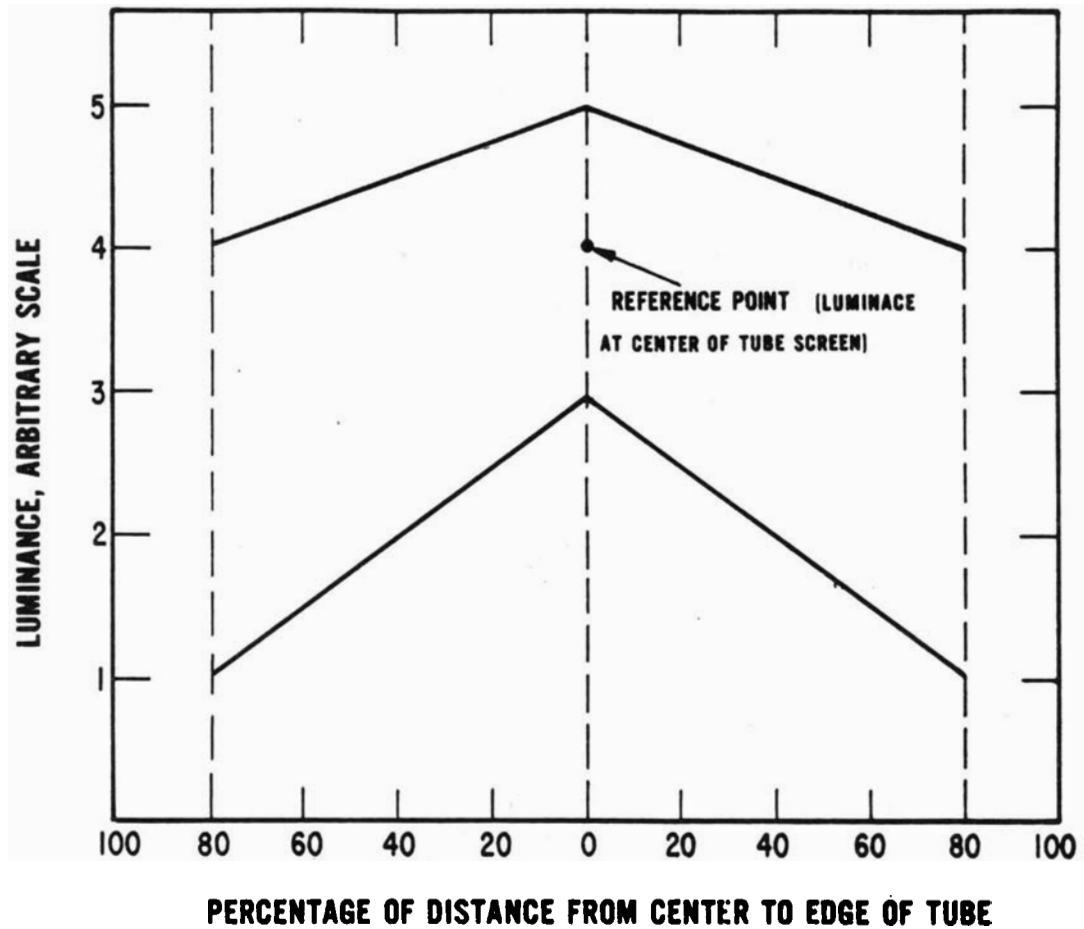

FIGURE 3. Luminance uniformity requirement.

TABLE 1. CATHODE AND SCREEN SPOTS FOR 18 mm TUBES

Largest Dimension of Spots mm	Number of Spots in Circles of Indicated Diameter		
	Inside 5.6 mm	Outside 5.6 mm Inside 14.7 mm	Outside 14.7 mm Inside 17.8 mm
≥0.38	0	0	0
0.3 to <0.38	0	1	2
0.23 to <0.3	0	3	8
0.15 <0.23	0	9	18
0.076 to <0.15	3	30	40
0.025 to <0.076	10	35	--

TABLE 2. CATHODE AND SCREEN SPOTS FOR 25 mm TUBES

Largest Dimension of Spots mm	Number of Spots in Circles of Indicated Diameter		
	Inside 7.6 mm	Outside 7.6 mm Inside 20 mm	Outside 20 mm Inside 24.8 mm
≥0.38	0	0	0
0.3 to <0.38	0	1	2
0.23 to <0.3	0	3	8
0.15 to <0.23	0	12	26
0.076 to <0.15	3	40	--
0.025 to <0.076	15	--	--

4.18 Viewer Distortion

When measured in accordance with paragraph 5.16, the distortion shall be 20 percent or less.

4.19 Flare

When measured in accordance with paragraph 5.17, the flare rating of Class A devices shall be no lower than -1, and the flare rating of Class B devices shall be no lower than -3.

4.20 Temperature and Humidity

When subjected to the high and low temperature storage, operation, and thermal shock test in accordance with paragraph 5.18 and the humidity test in accordance with paragraph 5.19, the viewer (complete with objective lens, eyepiece, and batteries) shall show no resultant loosening, breakage or corrosion of any finish, optical coating, connection or component, no condensation of moisture within the optical system, no high voltage breakdown, and no failure to operate.

4.21 Vibration Resistance

After being subjected to the vibration test in accordance with paragraph 5.20, the viewer (complete with eyepiece, objective lens, and batteries) shall show no evidence of intermittent electrical contact, loosening of parts, failure or breakage of any connection or component, or any change in the quality of the image.

5. TEST METHODS

5.1 Sampling

One viewer shall be selected at random for test. If this viewer passes all tests, it is considered to have complied with this standard. If this viewer fails to meet any requirement of this standard, testing of the unit shall be terminated and a re-test sample of two additional viewers shall be selected at random and subjected to test. If both additional viewers meet all requirements, the sample is considered to have complied with the standard.

5.2 Testing Schedule

The testing sequence shall follow the numerical order of test method presentation within this standard.

Tests for optical gain, output screen luminance, contrast transfer function, flare, temperature and humidity, and vibration shall be repeated using each objective lens supplied with the viewer. All other viewer optical tests shall be performed one time, using any of the objective lenses supplied with the viewer.

5.3 Test Rooms

Optical tests must be performed in laboratories in which the luminance of any light source of leak does not exceed 1×10^{-5} cd/m². The luminance of a sheet of white paper placed in any area viewed by the photometer during a test shall not exceed 1×10^{-9} cd/m², with all lights off. Precautions must be taken to shield pilot lights on telephones and equipment, and electronic tubes, so that no stray light escapes.

A minimum room size of 3.2 x 7.3 m (9.8 x 22.2 ft) is required for all tests except distortion and flare, which require a minimum size of 2.5 x 20 m (7.6 x 61 ft). The length of the latter room must be at least 8 m (24.4 ft) plus 133 times the focal length of the longest focal length objective lens on a device to be tested. A minimum room height of 2.5 m (7.6 ft) is required.

5.4 Test Equipment

5.4.1 Variable Luminance Light Source

The light source shall have the spectral distribution of CIE Standard Source A,¹ be completely diffuse, be uniform in luminance to within 2 percent over its entire area, and have a luminance that is variable over the range of 1×10^{-4} to 100 cd/m². For the light induced background test, the source shall be large enough to fill the entire field of view of the viewer being tested, at a distance

of 1 m. The vertical dimensions of the source when measuring luminance uniformity must be larger than the effective diameter of the objective lens to be tested plus the diameter of the image intensifier tube in the device. For all other tests, the minimum diameter of the source must be larger than the effective diameter of the objective lens on the device to be tested. A source meeting these requirements is described in appendix A. The use of a large area plane illumination source is satisfactory, but is difficult to design in accordance with the above requirements.

5.4.2 Photometer

The photometer shall measure luminance over the range of approximately 5×10^{-5} to 100 cd/m^2 . The photometer must have at least three objective lenses: one of the long focal length, approximately 180 mm; one of intermediate focal length, providing 1 to 1 magnification at a viewing distance of approximately 10 cm; and a microscope objective having 10x magnification, for use as a microphotometer.

The photometer shall have six apertures located in the objective lens image plane, five circular and one in the form of a rectangular slit. The circular apertures shall subtend conical angles of view having included plane angles of approximately 2, 6 and 20 minutes, and 1 and 3 degrees, and fields of view, when used with the 1x magnification lens, having diameters of approximately 0.1, 0.3, 1.0, 3.0, and 10.0 mm. The slit aperture shall have a length ten times its width, and when used with the 10x-magnification lens, the field viewed by the slit shall be no larger than 5 by 50 μm .

The size of the various apertures may vary by as much as 20 percent from these requirements, but the actual size shall be known to at least 1 percent.

The photometer shall provide both a digital display, reading in cd/m^2 , and an analog voltage proportional to the digital display. When properly calibrated, by use of a large-area source of known luminance,³ the photometer error shall not exceed 5 percent, and the repeatability over a period of 1 hour shall be within 1 percent over the entire range.

A suitable photometer can be assembled from modular components manufactured by Gamma Scientific, Inc., 3777 Ruffin Road, San Diego, California 92123. The Spectra-Pritchard Model 1980 with 25 x 250 μm slit aperture option and CDB control console, manufactured by the Photo Research Division of Kollmorgen Corp., 300 North Hollywood Way, Burbank, California 91505 is also suitable.

5.4.3 Linear Motion Device

A linear motion device is required to move the resolution chart vertically in front of the aperture of the light source during the contrast transfer function test and to move the viewer vertically during the luminance uniformity test. The linear motion device shall have constant vertical speeds in the range of 1 to 15 mm/min and be capable of driving a load of 10 kg (22 lbs) with essentially no angular movement of the load while moving. A suitable device is described in appendix B.

5.4.4 Blackbody Cavity

A blackbody cavity, with an aperture at least 1.75 cm in diameter, is required for use with the integrating sphere source for the light induced background test. The diffuse-normal reflectance of the cavity aperture shall not exceed 0.1 percent. A cavity meeting these requirements is described in appendix C.

The use of a large area plane illumination source for the light induced background test requires a black dot rather than a black body. A suitable black dot is described in appendix D.

5.4.5 Adjustable Testing Mounts

One adjustable mount shall provide horizontal adjustment in directions parallel and normal to the optical axis. A second adjustable mount, for the photometer, shall provide micrometer

³ Boris Merick, Light and Color Measurements of Small Light Sources, pp. 70-71. General Electric Company (1968).

adjustment in a horizontal plane parallel and normal to its line of sight, and in a vertical direction normal to the line of sight.

5.4.6 Test Charts

Three test charts are required: two resolution charts of the Air Force 1951 design, a negative transparency and a positive reflection resolution test chart (figure 1), and a distortion chart. Both resolution test charts are available from the Graphic Arts Research Center, Rochester Institute of Technology, Rochester, New York 14623. The negative transparency is identified as Resolution Test Object, TR-3-72 and the positive reflection chart as Large Scale Test Object, Water Resistant. For use, the reflection chart must be cemented to a rigid flat backing, such as plywood.

The distortion chart (figure 4) is 1.8-m square plane, to within about 6 mm, painted white, and consists of a square grid of black lines, 3 mm-wide on 10-cm centers. A center square with sides at 45° to the grid axis is formed by diagonals of the four squares whose corners meet at the center. The chart is attached to a mount that can be adjusted for tilt about vertical and horizontal lines, and provision for mounting a first-surface mirror at the center of the chart with its surface parallel to that of the chart is required.

5.4.7 Flare-Light Sources

Three flare-light sources are required, each providing a conical beam having an included plane angle of 5 degrees. A sketch of a suitable flare-light source is shown in figure 5.

5.4.8 Vibration Table

A vibration table or fixture capable of imparting simple harmonic motion to a mass of 5 kg (11 lbs) in both horizontal and vertical planes at frequencies from 5 to 200 Hz is required. It shall be capable of providing peak-to-peak displacement of 2.5 mm (0.1 inch) over the frequency

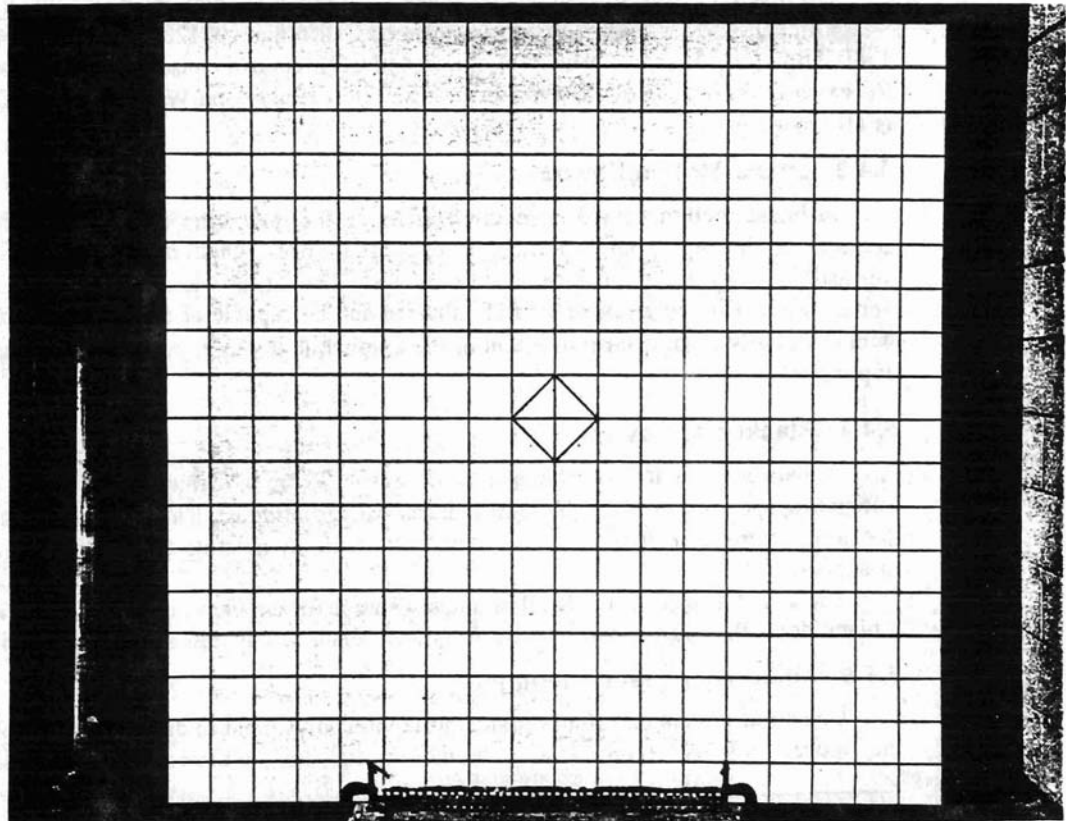

FIGURE 4. Distortion test chart.

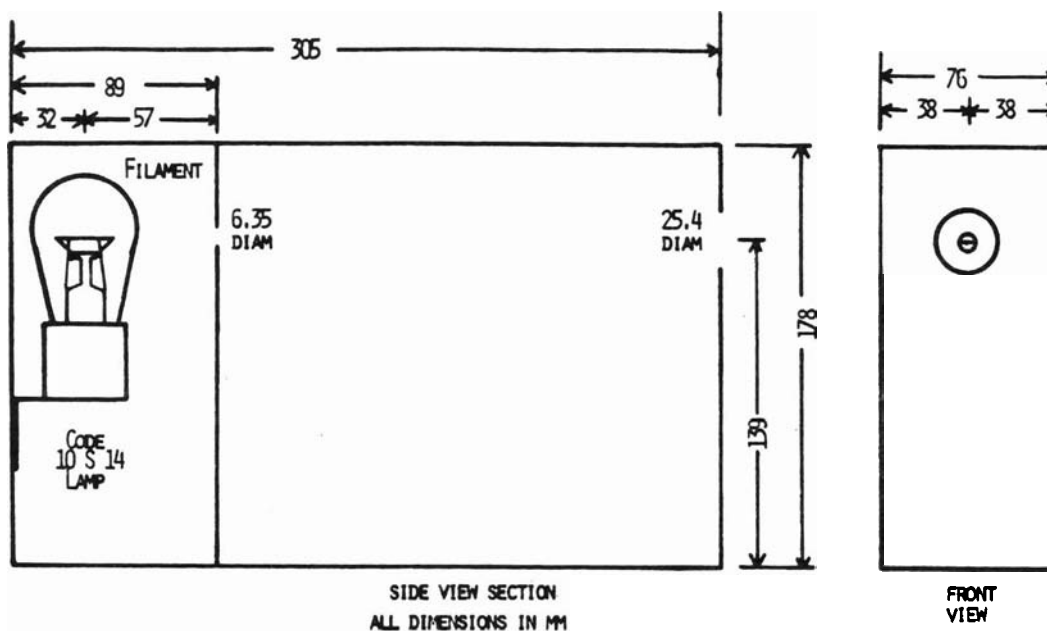

FIGURE 5. Cross sectional view of flare-light source.

interval from 5 to 20 Hz, constant acceleration levels of ± 2 g in the interval from 20 to 33 Hz, constant peak-to-peak displacement of 0.9mm (0.035 inch) in the interval from 33 to 52 Hz, and constant acceleration levels of ± 5 g at frequencies above 52 Hz.

An accelerometer and cathode ray tube display or chart recorder shall be available for monitoring the frequency, amplitude, and waveform of the motion imparted to the viewer during test.

5.4.9 Environmental Test Chambers

Two environmental test chambers are required: one which can maintain temperatures in the range from 22 to 50°C (72 to 122°F) with temperature control to $\pm 1^\circ\text{C}$ ($\pm 1.8^\circ\text{F}$) and maintain relative humidity between 90 and 98 percent, and another which can provide temperatures from 22 to -25°C (72 to -13°F) with temperature control to $\pm 1^\circ\text{C}$ (1.8°F). The working volume of each chamber shall be not less than 30 x 30 x 45 cm (1 x 1 x 1.5 ft). Recorders shall be provided to record temperature and humidity continuously during a test.

5.5 Configuration

Examine the night vision device to determine compliance with paragraphs 4.2 through 4.8.

Mount the viewer on a tripod, free to rotate in a vertical plane only, and measure the vertical force necessary to maintain the viewer in a horizontal plane, using a spring balance. Compute the torque required to maintain this position from the measured vertical force and horizontal distance from the point of measurement to the vertical plane through the horizontal axis of rotation.

Repeat the above inspection and measurement for each viewer lens and accessory combination, and for each mounting/support plate furnished with the viewer.

5.6 Eyepiece Tests

5.6.1 Radiation

Place the viewer eyepiece in a shielded container with the surface normally closest to the eye adjacent to the alpha radiation counter. Count the radioactive particles detected for a period of 5 minutes. Remove the eyepiece from the shielded container and count the background for 5 minutes. Divide the eyepiece radiation count by the background radiation count.

5.6.2 Focus

Place the eyepiece in a temporary mount and adjust it to the approximate center of its adjustable range with a target 13 mm in front of it. Place a diopter tester against the eyepiece and adjust the tester for clear focus of the target as seen through the eyepiece and diopter tester. Record the reading on the diopter tester. Adjust the eyepiece to both extreme settings, and record the reading on the diopter tester for clear focus at each position.

Rotate the eyepiece lens using a torque wrench and adapter, first clockwise and then counterclockwise, and observe the reading on the torque wrench in each case.

5.6.3 Curvature of Field

Test the eyepiece lens for curvature of field by method 17, paragraph 5.1.2.13.2; focal length by method 2, paragraph 5.1.2.2.2; and aperture ratio (f-number) by the method described in paragraph 5.1.2.8, all of MIL-STD-150A,⁴ June 8, 1961. Compute the depth of focus in mm as $0.04N$ where N is the aperture ratio of the eyepiece lens.

5.6.4 Distortion

Measure the distortion of the eyepiece lens by method 28, paragraph 5.1.2.16.4 of MIL-STD-150A, June 8, 1961.

5.7 General Test Procedures

Perform all optical tests of night vision devices with the viewer equipped with fully charged batteries—total period of prior use not to exceed four hours. Allow the viewer to stabilize for a minimum of 5 minutes after it is turned on before performing any tests.

Do not turn on the viewer in a brightly lighted room unless the objective lens is capped. Although the automatic brightness control will protect the tube from burning out if it is accidentally turned on in bright light, operation under such conditions may result in decreased tube life.

Allow the photometer to stabilize for a minimum of 30 minutes after it is turned on before making any measurements. Prior to use, calibrate the photometer against the internal source and adjust the zero and dark currents.

Permit the light source to stabilize for a minimum of 5 minutes after any lamp is turned on.

5.8 Optical Gain test

Adjust the light source to a luminance of 0.01 cd/m^2 and position the photometer 40 cm from and normal to the source. Measure and record the luminance using the 180 mm lens and 1° aperture. Move the photometer forward, 15 cm from the source, and measure and record the luminance using the 90 mm lens and 1° aperture. Calculate the correction factor C as

$$C = (180 \text{ mm lens reading}) / (90 \text{ mm lens reading}).$$

Repeat this measurement a minimum of 10 times to obtain a standard deviation of less than 0.005 for the mean of C . Check the correction factor at intervals of 4 to 6 weeks, unless one of the lenses is cleaned, which requires that a new correction factor be established.

Place the viewer on an adjustable mount, positioned against a lateral movement stop, immediately in front of the light source, with the viewer axis centered on and normal to the aperture. Focus the viewer on the source and remove the eyepiece. Position the photometer, on an adjustable mount, 17 cm behind the viewer output screen, aligned with the viewer axis as shown in figure 6. Adjust the source luminance to $9.00 \times 10^{-3} \text{ cd/m}^2$.

Focus the photometer on the viewer output screen using the 90 mm objective lens and 1° aperture, measure the luminance and record the value. Note and record the time of measurement. Move the viewer out of the photometer line of sight, replace the 90 mm objective lens with the 180 mm lens and, still using the 1° aperture, focus on the source, measure and record the luminance.

⁴ Available from Naval Publications and Forms Center, 5801 Tabor Avenue, Philadelphia, Pa. 19120.

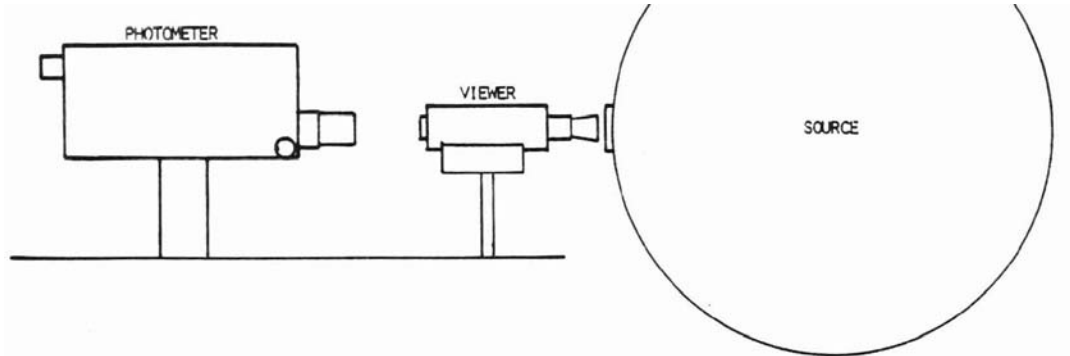

FIGURE 6. Equipment arrangement for optical gain and light equivalent background tests.

Measure the viewer screen and source luminances at 10 values of source luminance from 1×10^{-4} to 10 cd/m^2 , varying by a factor of about 4 between successive values, and again at $9.00 \times 10^{-3} \text{ cd/m}^2$. Record the time of the last measurement.

Compute the optical gain, G , for each source luminance level as:

$$G = \frac{\text{Screen Luminance}}{\text{Source Luminance}} \times C$$

Plot the optical gain, G , as a function of the logarithm of the source luminance to produce the optical gain curve of the viewer (semi-log paper is convenient). The maximum optical gain in the range of source luminance from 1×10^{-4} to 10 cd/m^2 is the optical gain of the viewer.

Measurement of the optical gain of a viewer with an objective lens of known focal length F in mm, T-number T and f-number f permits the calculation of the optical gain of the viewer when used with any other objective lens for which the same parameters are known.

Compute the transmittance, τ , for each lens as

$$\tau = f^2/T^2$$

Compute the magnification, M , for each lens as

$$M = F/(D-F)$$

where D is the distance from the object to the lens, which may be taken as 50,000 mm.

Compute the optical gain, G , of the viewer with lens 2 from the measured optical gain, G_1 , with lens 1, by use of the following equation, where the subscripts indicate the parameters of lenses 1 and 2 respectively.

$$G_2 = \frac{G_1 \cdot \tau_2 \cdot [(2f_1)^2 \cdot (M_1 + 1)^2 + 1]}{\tau_1 \cdot [(2f_2)^2 \cdot (M_2 + 1)^2 + 1]}$$

5.9 Optical Gain Stability Test

The percentage change in optical gain per hour of operation, ΔG , is computed from the optical gain, G_B , measured at a source luminance of $9.00 \times 10^{-3} \text{ cd/m}^2$ at the beginning of the optical gain test, the optical gain G_E , measured under the same conditions at the end of the optical gain test, and the elapsed time, Δt , in hours between the two tests, Δt not to exceed 2 hours.

$$\Delta G = \frac{G_B - G_E}{G_B \times \Delta t} \times 100$$

5.10 Light Equivalent Background Test

Following completion of the optical gain test, cap the objective lens of the viewer and measure the luminance of its output screen as L_o . Compute the light equivalent background, L.E.B., as

$$\text{L.E.B.} = L_o/G_o$$

where G_o is the optical gain, measured at the lowest value of luminance of the source, approximately $1 \times 10^{-4} \text{ cd/m}^2$.

5.11 Light Induced Background Test

The photometer calibration requires a small black dot target. Cut 0.5-mm (0.020 in) diameter dot from brass shim stock, blacken it with india ink, and mount it on a piece of flashed opal glass on the side opposite the flash. Place this target in a vertical position on a translation stage providing horizontal and vertical motion in the plane of the glass and illuminate it from the rear with a frosted 40 watt light bulb, 17 cm from the glass, shielded with a 5 cm diameter tube blackened on the inside, as shown in figure 7. Mount the photometer, using the 90 mm objective lens, on an adjustable stage providing motion parallel and normal to its line of sight in the horizontal plane. Center the dot in the photometer field of view, focus upon the dot, bring the 6' aperture into the field of view, and center it on the dot. Adjust the photometer focus until the measured luminance is at its minimum. Measure and record the luminance of the dot L_D . Move the glass until the aperture appears to be separated from the dot by approximately the diameter of the dot, measure and record the luminance of the light area L_L . Compute the veiling glare V.G. of the photometer as

$$\text{V.G.} = L_D/L_L.$$

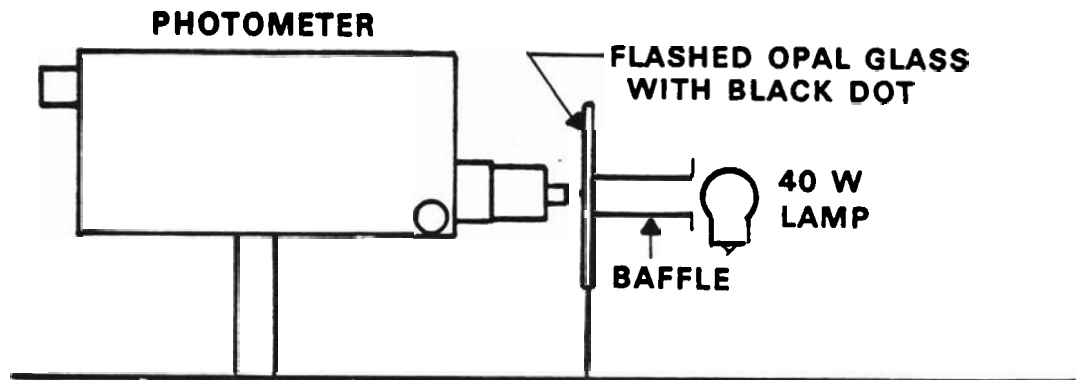

FIGURE 7. Equipment arrangement for measuring veiling glare of photometer.

Place the viewer on an adjustable mount, positioned against a lateral movement stop, immediately in front of the light source, with the viewer axis centered on the aperture and normal to it. Position the photometer, in an adjustable mount, 17 cm behind the viewer output screen, aligned with the viewer axis. Remove the plug in the back wall of the light source sphere and place the black body cavity behind and centered on the hole (figure 8). Focus the viewer on the hole, then remove the eyepiece, and focus the photometer on the output screen, using the 90 mm objective lens. Adjust the viewer to center the image of the hole on the screen. (If the screen has an etched reticle, the image should be near the center but not on the reticle lines). Bring the photometer aperture nearest the size of the image (bigger or smaller) into the field of view and center it on the image. Adjust the viewer objective lens, focusing to achieve minimum luminance as measured by the photometer, and then adjust the photometer focus until the measured luminance is minimum. Bring an aperture $\frac{1}{3}$ to $\frac{2}{3}$ the size of the hole image into the field of view, center it on the image, measure the luminance L_B of the image and record. Move the photometer horizontally until the aperture is separated from the hole image by the diameter of the hole imaged, measure the luminance of the light background L_L , and record. Measure L_B and L_L at 10 levels of source luminance covering the range from 1×10^{-4} to 10 cd/m^2 .

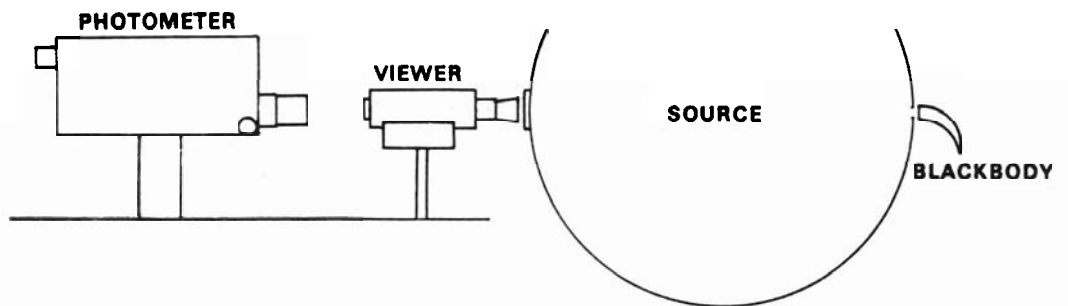

FIGURE 8. Equipment arrangement for light induced background test.

Compute the light induced background, L.I.B., for each level of source luminance as

$$\text{L.I.B.} = (L_B/L_L) - \text{V.G.}$$

The maximum value measured in the range of 1×10^{-4} to 10 cd/m^2 is the light induced background of the viewer.

5.12 Output Screen Luminance Test

The highest value of screen luminance, determined in the test for optical gain (para 5.8), times the calibration factor C (para 5.8) is the luminance of the output screen.

5.13 Luminance Uniformity Test

Mount the viewer on the automatic scanning device, with the objective lens 1 cm from and normal to the source aperture and with the eyepiece removed, as shown in figure 9. Mount the photometer, using the 90 mm objective lens and $20'$ aperture, 20 cm behind the viewer, aligned with the viewer axis. Connect the scanner potentiometer to the x axis of an x-y recorder and the photometer analog output to the y axis. Adjust the source luminance to approximately 0.01 cd/m^2 . Center the photometer on the output screen and adjust the photometer and y axis recorder span to between 60 and 80 percent of full scale.

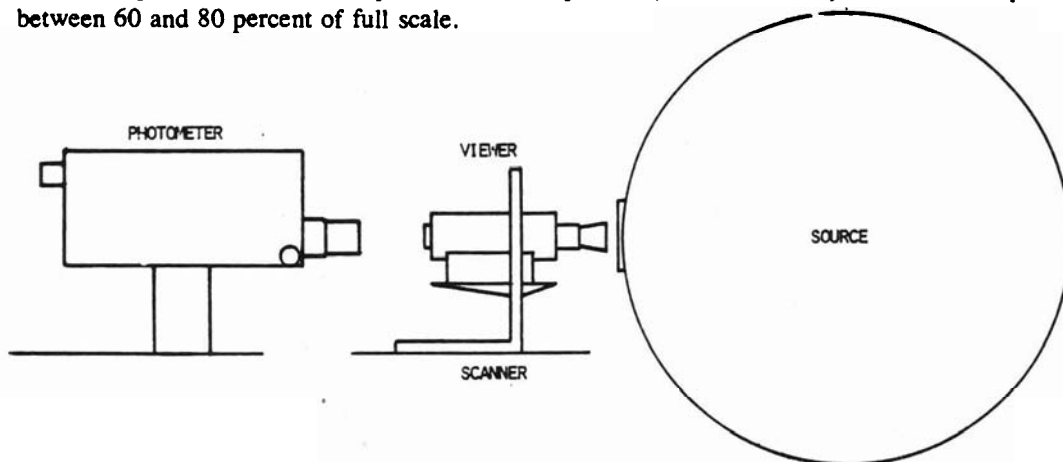

FIGURE 9. Equipment arrangement for luminance uniformity test.

Manually scan the viewer upward until the photometer aperture is just below the image of the viewer output screen. Set the scanner potentiometer to zero, adjust the recorder x-axis to zero, and adjust the span to nearly full scale for a viewer movement of slightly more than the screen diameter. Scan the viewer downward automatically along the vertical diameter of the viewer at a speed of about 2 mm/min until the image is below the photometer aperture.

Normalize the recorded viewer output screen luminance to a set y-value of 4.0 at the center of the screen and x-values of 100 at the points where the curve falls to zero. Draw the limits on the normalized curve as shown in figure 3.

5.14 Cathode and Screen Quality Test

Position the viewer with eyepiece removed in front of the source aperture as in figure 6. Cap the viewer lens and examine the phosphor screen for defects with the room lights off. Use a low power microscope (3 to 5x magnification) or the photometer with 90 mm objective lens and low magnification (3.3x). Remove the cap and turn on the source at a luminance of approximately $1 \times 10^{-4} \text{ cd/m}^2$. Gradually increase the luminance while examining the screen until a luminance of 10 cd/m^2 is reached. Reduce the luminance to 0.01 cd/m^2 and examine the screen for dark and light spots with contrast of more than 30 percent relative to the background. Count the spots in the different areas as listed in tables 1 or 2. A spot with half or twice the luminance of the background will have a contrast of 33 percent and is readily visible. If in doubt, measure with the photometer and compute the contrast. Measure the spot sizes using a microscope with reticle scale or estimate by comparison with the photometer apertures.

5.15 Contrast Transfer Function Test

Mount the negative transparency resolution chart on the automatic scanner, 1 cm in front of and parallel to the plane of the light source aperture (see figure 10). Position the viewer 4.5 to 5 m from the source aperture, aligned normal to and centered on it when against the horizontal translation stop. Critically focus the viewer on the resolution chart with the source on. Remove the eyepiece and measure the distance D, in m, from the outer surface of the viewer objective lens to the chart, to the nearest cm.

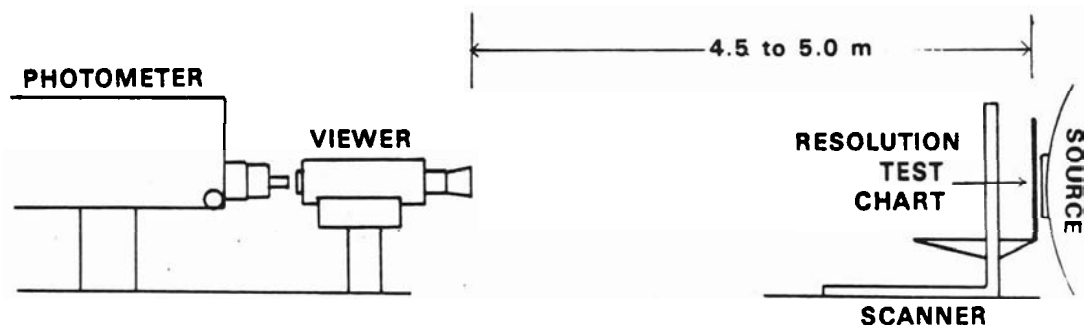

FIGURE 10. Equipment arrangement for contrast transfer function test.

Position the photometer, with its 10x microscope objective, 1 cm behind the viewer, aligned with the viewer axis. Move the viewer out of the line of sight of the photometer, install the 180 mm objective lens and focus on the target using the $6'$ aperture. Connect the photometer analog output to the y-axis of an x-y recorder, and the scanner potentiometer to the x-axis.

For class A viewers, adjust the source luminance to 0.001 cd/m^2 as measured on the large light area of the resolution chart (figure 1) near the center at the top of the target. For class B viewers, adjust the source luminance to 0.01 cd/m^2 . Replace the 180 mm objective lens with the 10x objective lens, move the viewer back in front of the photometer and critically focus upon the output screen. Critical focus is attained when the ends of the fiber optics can be clearly seen. Bring the slit aperture into the photometer field of view, and adjust the viewer or photometer to within 2 mm of axial alignment, avoiding the etched reticle if present on the output screen. Manually adjust the position of the chart until the slit aperture is centered on a bright line whose image is about the same width as the slit. Adjust the position of the chart until the photometer reading is at its maximum. Focus the viewer objective lens for the maximum photometer reading, and then focus the photometer to obtain the maximum reading. Repeat this focusing procedure at least one time to optimize the focus of both the photometer and viewer.

Manually drive the resolution chart to center the groups -2 to $+1$ relative to the source aperture and critically focus the viewer objective lens, observing the image with the photometer. Manually drive the chart to center the large light square about the photometer aperture. Set the photometer control to zero, and adjust the recorder to read zero on the y scale. Set the photometer control to read the luminance of the chart. Adjust the photometer output to maximum, and adjust

the recorder y axis span to between ½ and full scale. Set the x-axis span for slightly less than full scale for the full range of the scanner potentiometer movement.

Manually drive the resolution chart upward until the slit aperture is centered on the dark area below the square light area in the image of the resolution chart. Set the scanner potentiometer to zero and the scanning speed to approximately 3 mm/min. Scan the resolution chart downward automatically and record photometer and potentiometer outputs until the slit is about centered in the square light area. Then move the resolution chart until the aperture is in the dark area below the -4(1) pattern in the image of the chart, set the potentiometer to zero, and scan automatically at about 3 mm/min, recording until the slit is in the dark area above the pattern.

Move the chart manually to successively smaller patterns and scan automatically until the recorded pattern can no longer be resolved as three distant peaks and two valleys. Then repeat the recording scan across the edge of the large square light area.

The lowest spatial frequency scanned should be no higher than 4 line pairs per mm, and a value of 2.5 or less is desirable. To get such low spatial frequencies with night vision devices having objective lenses of less than 50 mm focal length, it may be necessary to use a resolution pattern in the -5 or -6 groups. The fabrication of such patterns is discussed in appendix E.

Compute the magnification factor, M , of the objective lens of the viewer from the focal length, F , and the distance, D , from the resolution chart as

$$M = F/(D-F)$$

Compute the spatial frequency, f , of each pattern image scanned from the magnification, M , and the spatial frequency, f_c , of the pattern on the chart (table 3) as

TABLE 3. SPATIAL FREQUENCIES ON
RESOLUTION CHART

(LINE PAIRS PER MILLIMETER)

Pattern No.	Group No.							
	-6	-5	-4	-3	-2	-1	0	1
1	0.0156	0.0312	0.0625	0.1250	0.2500	0.5000	1.0000	2.0000
2	0.0175	0.0350	0.0702	0.1403	0.2806	0.5612	1.1225	2.2449
3	0.0197	0.0394	0.0787	0.1575	0.3150	0.6300	1.2599	2.5198
4	0.0221	0.0442	0.0884	0.1768	0.3536	0.7071	1.4142	2.8284
5	0.0248	0.0496	0.0992	0.1984	0.3969	0.7937	1.5874	3.1748
6	0.0278	0.0557	0.1114	0.2227	0.4454	0.8909	1.7818	3.5636

$$f = f_c/M$$

Compute the contrast modulation, C_t , at the frequency, f , from the average heights above zero of the peaks, L_D , and the valleys, L_L , of the recorded scan, as

$$C_t = (L_L - L_D)/(L_L + L_D)$$

Compute the contrast of the chart, C_o , from the average heights above zero of the two curves made across the edge of the square light area recorded at the beginning and end of the test: $L_{L,o}$ in the light area and $L_{D,o}$ in the dark area:

$$C_o = (L_{L,o} - L_{D,o})/L_{L,o} + L_{D,o}$$

Compute the contrast transfer function, $CTF(f)$, at a frequency, f , from the contrast modulation, C_t , at the frequency, f , and the contrast modulation of the chart, C_o :

$$CTF(f) = C_t/C_o$$

Plot the $CTF(f)$ as a function of spatial frequency, f , to produce the CTF curve of the viewer. Draw a smooth line through the plotted points and interpolate the values at the required frequencies.

5.16 Distortion Test

Set up the distortion chart (figure 4) on its adjustable mount in front of a black background at one end of the laboratory and a surveyor's level at the other end. Adjust the surveyor's level to align its crosshairs with the horizontal and vertical lines at the center of the distortion chart while maintaining its optical axis horizontal. Attach a first-surface plane mirror, at least 12 cm square to the center of the chart, with the reflecting surface parallel to the surface of the chart. Establish a horizontal reference line, normal to the chart to within 0.5 degree and within 1 cm of its center, by focusing the telescope of the level upon the image of its objective lens and by tilting the chart about its horizontal and vertical axes until the telescope crosshairs are well centered upon the image of the objective lens and the center vertical and horizontal lines of the chart beyond the mirror. Remove the mirror and suspend a plumb bob through the horizontal reference line midway between the chart and surveyor's level.

Remove the viewer eyepiece, mount the viewer on a stable tripod, and turn it on. Place the viewer in front of the surveyor's level at a distance from the chart such that the chart image fills most of the output screen (see figure 11), and adjust the height of the viewer optical axis to that of the horizontal reference line. Align the optical axis of the viewer with the reference line first by eye, sighting along the top of the viewer and adjusting it until the line of sight passes through the cord of the plumb bob and the center vertical line of the chart. Next, focus the viewer alternately on the cord and the center line, adjusting its position until both images are coincidental with the vertical crosshairs seen through the surveyor's level. Remove the plumb bob, attach the relay lens and single lens reflex camera, and complete the alignment by removing the camera back and adjusting the position of the viewer until the rear element of the camera lens is well centered on the crosshairs of the surveyor's level.

Adjust the lights until the luminance of the light area of the chart is 0.01 cd/m². Load the camera with high speed panchromatic film (with an ASA exposure index of about 400) and set the built-in exposure meter to the correct film speed.

Critically focus the viewer on the chart, focus the camera, and photograph the viewer image at 1/8, 1/4, 1/2, 1, 2, 4, and 8 times the exposure indicated by the camera exposure meter. Process the film in accordance with the manufacturer's instructions. Examine the film with a low power microscope, and mount the two negatives showing best contrast between 8.25 x 10 cm (3 1/4 x 4 inch) slide cover plates.

Place the mounted negatives on the stage of a traveling microscope (3 to 5x) that will allow measurement of horizontal and vertical reference distances to within 0.01 mm. Measure the diameter of the viewer screen image on both negatives at approximately 45 degrees to the major axes of the distortion chart grid images and compute the average radius, R, of the viewer output screen (see figure 11).

Measure the distance between the two horizontal grid lines on either side of the center horizontal grid line at their intersections with the vertical grid line through the origin. Do this five times on both negatives and compute the average V_o.

Measure the distance, V_x, between these same two horizontal grid lines at a distance of 0.8 times the viewer screen radius, R, from the vertical grid line through the origin on both sides of the origin (see figure 11). Do this five times on both negatives, and compute the average V_x.

Calculate the percent viewer distortion (%D) as:

$$\%D = \frac{V_x - V_o}{V_o} \times 100$$

5.17 Flare Test

Place the large resolution chart in front of the distortion chart and place the three flare lights with their filaments 4 meters in front of the distortion chart and 1.18 meters from the distortion chart reference line (par. 5.16), one on each side of and level with it and the third directly above it (figure 12). Position the viewer and attached camera with their axes coincidental with the reference

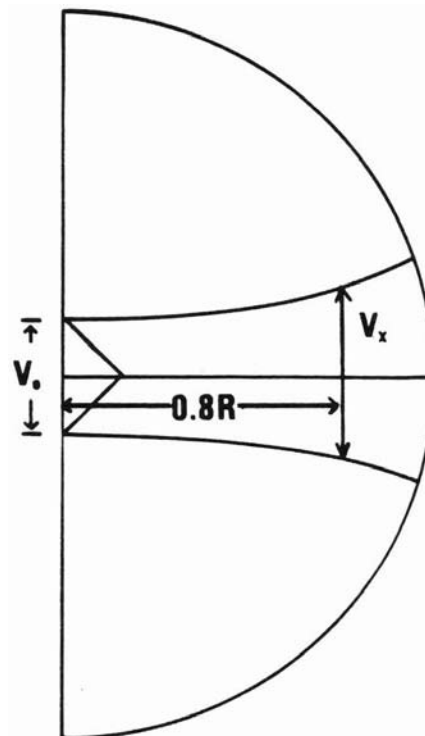
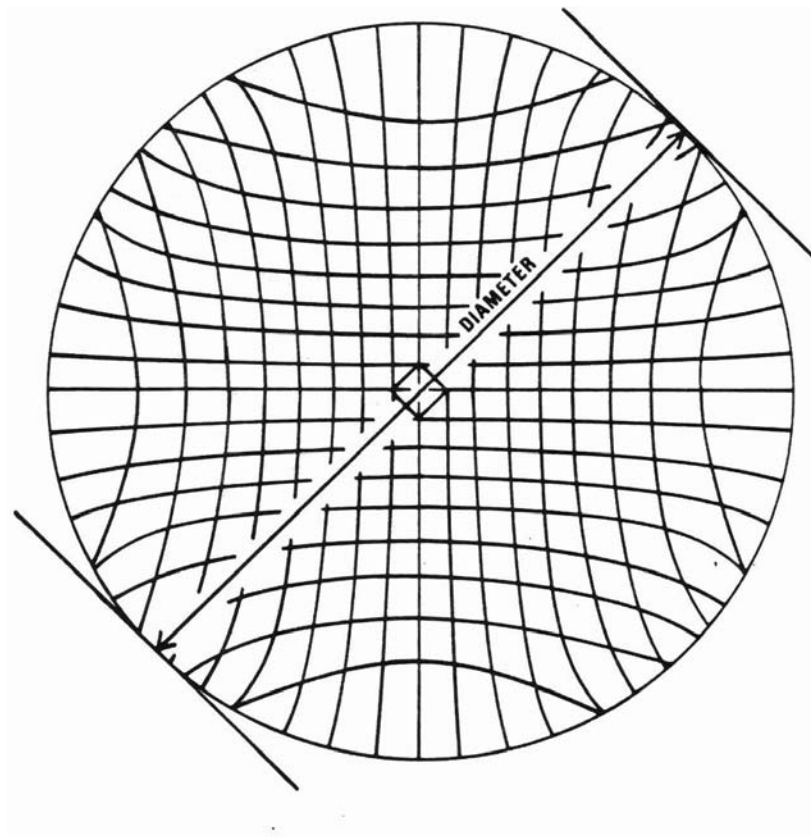

FIGURE 11. Distortion chart image and required measurements.

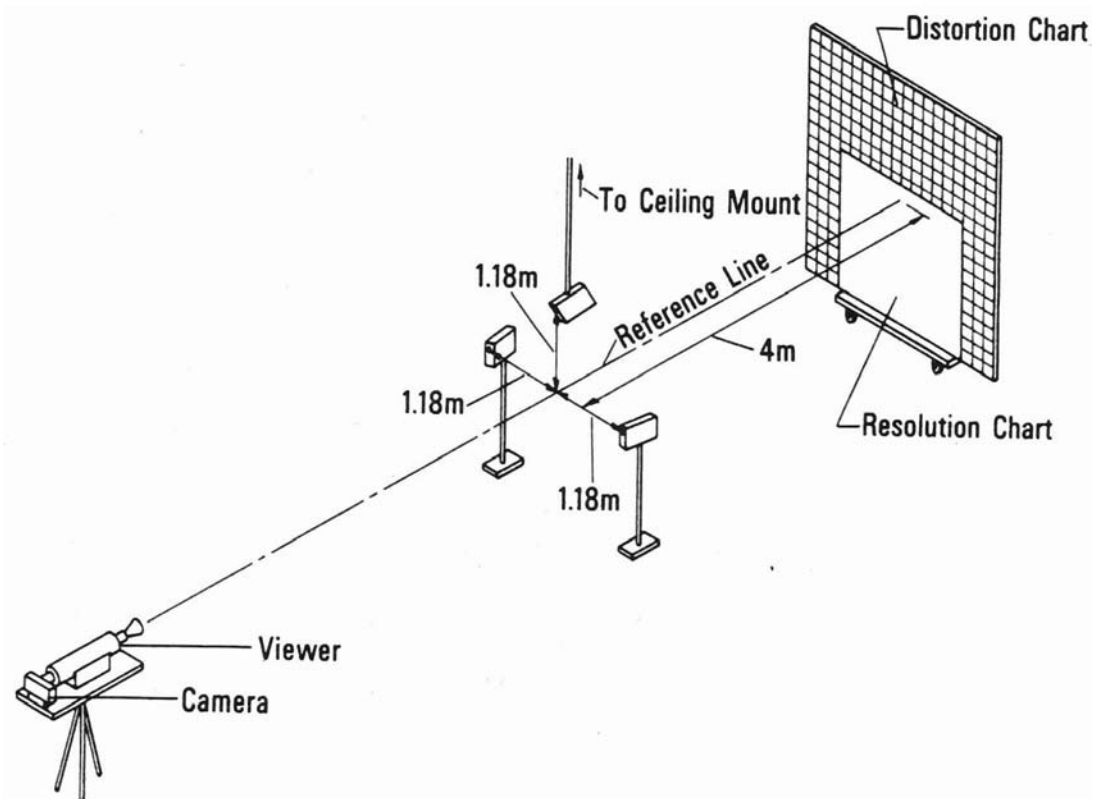

FIGURE 12. Equipment arrangement for flare test.

line, at a distance from the chart equal to 133 or 95 times the focal length of the viewer objective lens, for viewers with 18 and 25 mm tubes, respectively, such that the flare lights are just outside of the viewer field of view. Tilt the resolution chart slightly forward from its base to eliminate specular reflections into the viewer.

Align each flare light such that its beam is well centered on the objective lens of the viewer, With the flare lights off, illuminate the resolution chart to a level of 0.01 cd/m² on the light area, critically focus the viewer on the resolution chart, and photograph the scene at the exposure indicated by the camera exposure meter and ½ and 2 times this exposure, using high speed panchromatic film. Photograph the scene again at the same three exposures with each of the flare lights in turn illuminating the objective lens of the viewer. Process the film in accordance with the manufacturer's instructions.

Examine the negatives of the scene with flare lights off, using a microscope of about 20 x magnification, and determine for each the smallest pattern that can be seen to consist of three distinct lines. Compute the resolution number R for each negative as

$$R = 1 - P - 6G$$

where G is the group number (always negative on the large resolution chart) and P is the pattern number (always positive) of the smallest resolved pattern.

Identify the negative with the best resolution, or the one which appears to have the highest contrast (judged visually) if two or more have the same resolution, and note the exposure at which it was taken. Calculate the resolution number for each of the three negatives, made with the respective flare lights on, that were taken at this same exposure.

Subtract the largest resolution number of the three flare light scene negatives from that of the negative without flare light. The resulting number is the flare rating of the viewer.

5.18 High and Low Temperature Storage, Operation and Thermal Shock Tests

Stabilize the high temperature test chamber at $50\pm 2^{\circ}\text{C}$ ($122\pm 3.6^{\circ}\text{F}$) and 94 ± 4 percent relative humidity. Place the night vision device, which has been stored at room temperature ($22\pm 2^{\circ}\text{C}$, $72\pm 3.6^{\circ}\text{F}$) for at least 4 hours prior to test, in the chamber for 8 hours. During the last 30 minutes of this period, turn on the night vision device and check to see that a normal image is produced in a dark environment. At the end of the 8-hour period, remove the night vision device from the chamber and store it at room temperature for a minimum of 2 hours.

Then place the night vision device in a low temperature test chamber, maintained at $-25\pm 2^{\circ}\text{C}$ ($-13\pm 3.6^{\circ}\text{F}$), for 10 hours. Turn on the night vision device during the last 30 minutes of this period and check to see that a normal image is produced in a dark environment. A battery pack kept at room temperature, external to the chamber, may be used to operate the unit. Remove the night vision device from the chamber and store for at least 4 hours at room temperature. Turn on the viewer during the last 10 minutes of this period and observe its operation. This completes one cycle of high and low temperature storage, operation, and thermal shock. Repeat the complete cycle once. Examine the viewer for evidence of damage immediately following the test.

5.19 Humidity Test

Place the night vision device in a high temperature test chamber at $22\pm 2^{\circ}\text{C}$ ($72\pm 3.6^{\circ}\text{F}$) and 94 ± 4 percent relative humidity for 4 hours. Increase the temperature of $50\pm 2^{\circ}\text{C}$ ($122\pm 3.6^{\circ}\text{F}$) in a period of 2 hours or less, the relative humidity being maintained, and hold at that temperature for 4 hours, then reduce the temperature to 22°C in not more than 2 hours. This constitutes one complete cycle. Repeat the cycle 5 additional times, for a total of 6 cycles. Turn on the night vision device and observe its operation during the last 30 minutes of the fourth and sixth cycles. Examine the viewer for evidence of damage immediately following the test.

5.20 Vibration Test

Mount the viewer, complete with eyepiece, objective lens and batteries on a vibration table, with one accelerometer attached to the viewer near the objective lens and another attached to the vibration table. Connect both accelerometers to oscilloscopes or recorders. Subject the viewer to simple harmonic motion separately in three mutually perpendicular directions: parallel to the optic axis and in the horizontal and vertical planes through the optic axis. Sweep through the range from 5 to 200 Hz at the rate of 20 octaves per minute for a total of 5 sweeps for each axis, with amplitudes and accelerations as specified in figure 13.

During the frequency sweeps, observe the oscilloscopes or recorders and note the frequencies and relative magnitudes of any resonances. If resonances are noted, vibrate the viewer at each of the noted resonances for two periods of 5 minutes each, with a 2 minute rest period between periods of vibration, the amplitude or acceleration being as specified for that frequency in Figure 13. If more than four resonances are noted, vibrate the viewer at only the four resonances with the greatest relative amplitudes. If no resonance is noted, vibrate the viewer at a frequency of 20 Hz for two 5 minute periods.

If physical damage is observed at any time during the test, terminate the testing immediately.

Following vibration, inspect the viewer for proper operation and any evidence of mechanical failure, with particular emphasis on the condition of the objective lens and mounting.

APPENDIX A—LIGHT SOURCE

A light source especially designed for the testing of night vision devices is shown in figure 14. It consists essentially of a 1 m diameter integrating sphere, with a 50 cm diameter integrating sphere below and attached to it through an 18 cm diameter iris diaphragm. Four recessed light fixtures are mounted on the lower sphere, 90° apart in a horizontal plane 10.5 cm above the center of the lower sphere, with their axes passing through the center of the sphere, so that they are

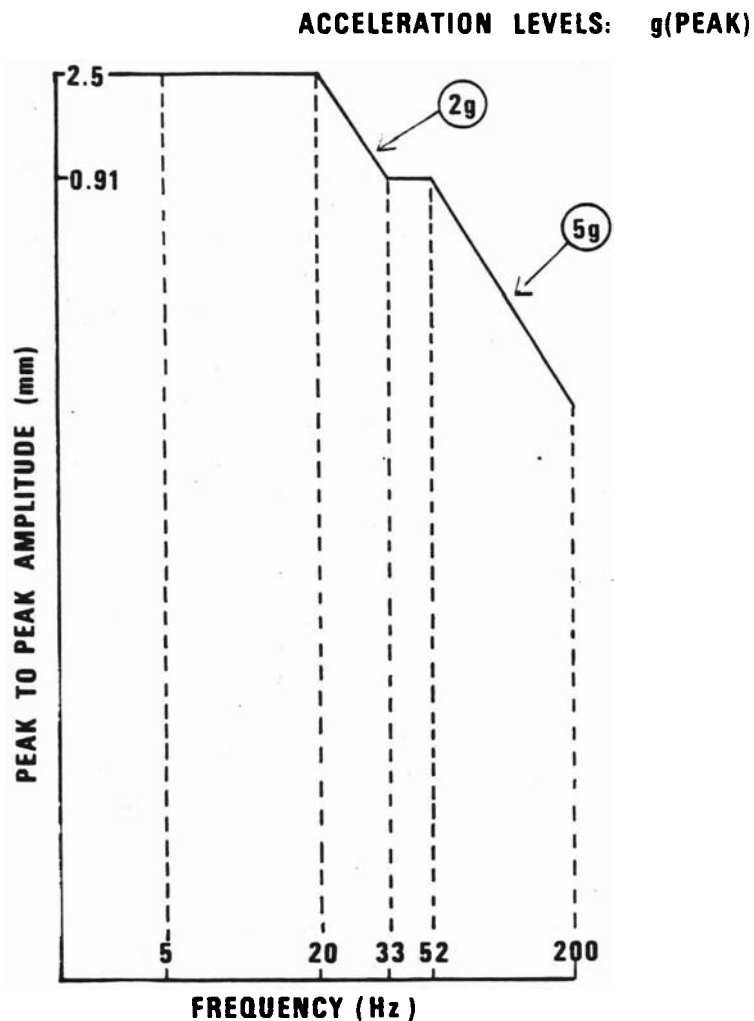

VIBRATION TEST AMPLITUDE Vs FREQUENCY

FIGURE 13. Vibration test amplitude as a function of frequency.

pointed downward at an angle of about 23.5° to the horizontal. Each fixture is cylindrical, about 13.5 cm in diameter and 14 cm long, and holds one 6.6 ampere, 7 volt General Electric Code Q45PAR 36 airport light. This is a prefocused quartz-halogen tungsten filament lamp. Each lamp is held in place so that its front surface is recessed about 5 cm from the inner surface of the sphere.

One lamp, identified as No. 1, has a 1.5 mm aperture and an opal glass filter in front of it. A second lamp, identified as No. 2, has an 18 mm aperture and an opal glass filter in front of it. The other two lamps, No. 3 and No. 4, have only the 9.5 cm diameter retaining ring as a limiting aperture. The lamps are connected in parallel, with separate switches. An electronic voltage regulator connected to a nominal 120 volt ac line supply maintains the input voltage constant at 120 volts $\pm 0.1\%$ for line voltage fluctuations from 105 to 135 volts. The output of the voltage regulator is connected to a variable voltage transformer with an output capacity of 2 kVA, and a voltage range of 0 to 135 volts. The output of the variable transformer is connected to the lamps through a 10 to 1 stepdown transformer.

There is a large aperture, 35 cm in diameter, in the large sphere, which is covered with a removable aperture plate having two apertures, 13 cm square, symmetrically placed 2.5 cm apart on either side of the center of the plate. A removable cover plate over the aperture plate has a single aperture 7 x 9 cm in size, centered over one of the 13 cm square apertures. The large sphere has a circular hole, 1.75 cm in diameter, diametrically opposite the large aperture. This hole subtends,

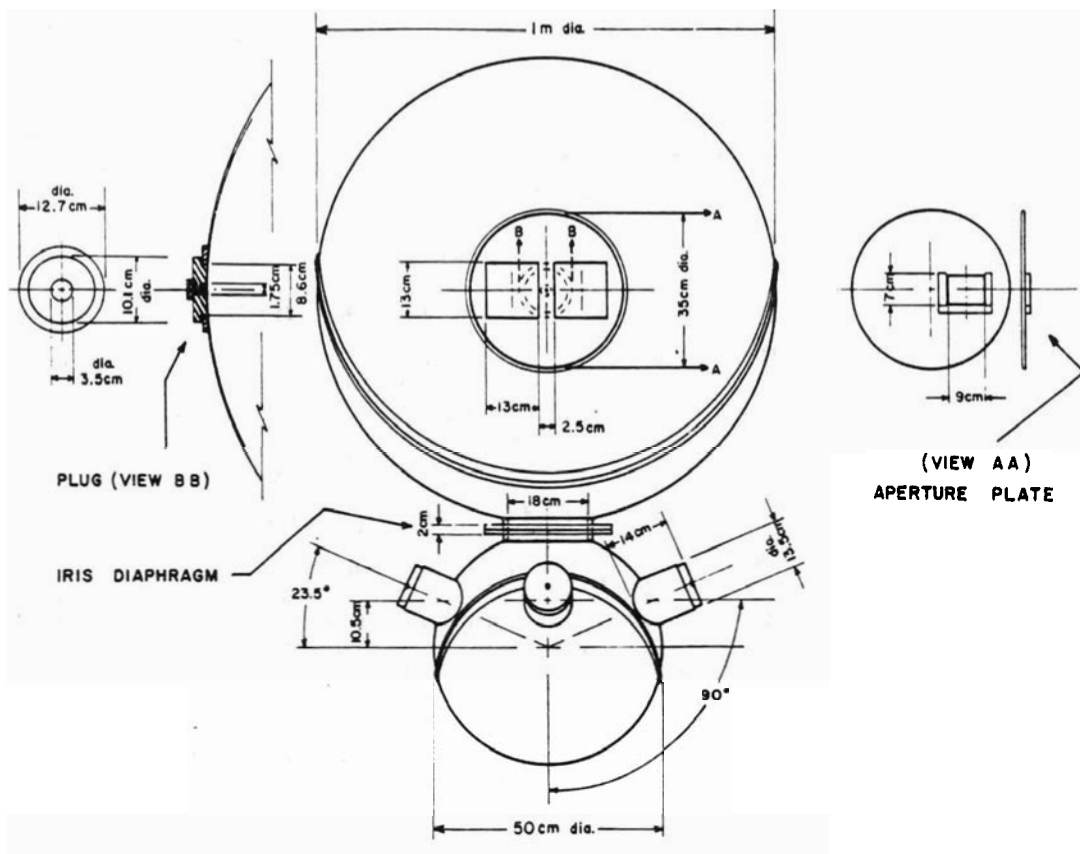

FIGURE 14. Integrating sphere light source.

from the large aperture, a conical solid angle with an included plane angle of 1° . The inner surface of this plug is concave spherically, with the same radius as the sphere. The plug has a shoulder spaced so that, when inserted with the shoulder in contact with the rim of the hole, the inner surface of the plug conforms to the inner surface of the sphere.

The inner surface of the small sphere is coated with barium sulfate paint.⁵ The inner surface of the large sphere, including the inner surface of all aperture plates and plugs, is coated with Burch sphere paint.⁶ The leaves of the iris diaphragm are of uncoated polished stainless steel.

The color temperature of the light in the large sphere was adjusted to 2856 K with all lights on and the iris diaphragm fully open. A light blue filter⁷ was required to overcome the slight yellowish cast of the Burch sphere paint. With the blue filter in place, the voltage to the lamps was varied until the desired color temperature was attained.

The luminance in cd/m^2 of the sphere wall opposite the aperture, with the iris diaphragm closed to its smallest diameter, was as follows: lamp No. 1— 2×10^{-5} , lamp No. 2—0.0026, lamps No. 3 or No. 4—0.22; and with the diaphragm fully open: lamp No. 1—0.005, lamp No. 2—0.9, lamps No. 3 or No. 4—78.

APPENDIX B—SCANNING DEVICE

A suitable scanning device is the Motor Driven Meter Mover, Model 31-6,⁸ extensively modified for use in these tests. Replace the variable-speed dc motor and control supplied with the unit with a 60 rpm synchronous ac motor having a torque rating of 0.25 newton meter (2.2 lbf-in.)

⁵ Available from Eastman Kodak Co., Rochester, N.Y. 14650.

⁶ Available from the Burch Paint Mfg. Co., 10609 Briggs Rd., Cleveland, Ohio.

⁷ Corning type 5900 glass, 2.1 mm (0.083 in.) thick.

⁸ Manufactured by Hoffman Engineering Corp., P.O. Box 300, Old Greenwich, Conn. 06870.

operating through a reduction gear system having gear ratios of 1, 2.5, 5, 10, 25, 50, 100, 250, 500, and 1000 to 1. The scanning speed at the 50 to 1 gear ratio (1.2 rpm) is 2.82 mm/min.

Connect a 10-turn potentiometer to the drive shaft through a magnetic clutch. Connect a low-voltage source through the potentiometer to produce a voltage that is proportional to the position of the scanner. Magnetic clutches are used to connect the main drive shaft to the scanner and to the potentiometer, because the motor is not reversible, and their use permits the scanner and potentiometer to be repositioned manually between scans.

Replace the chart holding device supplied with the scanner by a platform designed to hold a resolution chart, a viewer, or the photometer head.

APPENDIX C—BLACKBODY CAVITY

A suitable blackbody cavity, shown in figure 15, is in the form of an exponential horn. It is made from nominal 2.5 cm diameter Pyrex brand glass tubing tapered down to a point over a distance of about 12 cm. The tapered section is then bent on about a 6-cm radius to form the cavity.

The inside of the glass cavity is painted with a high-gloss black enamel paint and the outside is painted with a matte black paint. The reflectance of the cavity is less than 0.1 percent.

APPENDIX D—PLANE SOURCE SPOT

The use of a large area plane illumination source for optical testing of night vision devices requires the use of a black dot for the measurement of light induced background (paragraph 5.11). A circular metal disc of appropriate size may be used as the black spot. The diameter of the disc is 0.0175 times the distance from the objective lens of the viewer to the source. This disc should be painted with a very low reflectance diffusely reflecting black paint, such as Parsons Optical Black,⁹ or covered with black velvet cloth, and attached to the surface of the diffusing screen with doublefaced pressure sensitive tape.

The use of a large-area source requires that the test be made in a darkroom with walls painted with a matte black paint in order to minimize reflection of light from the source back to the surface of the black spot. As an alternative, curtains of black velvet may completely surround the equipment during test.

APPENDIX E—LARGE SIZE RESOLUTION CHART PATTERN FABRICATION

For contrast transfer tests of night vision devices with objective lenses of 50 mm focal length, resolution patterns (figure 1) in the -5 group are required, and resolution patterns in the -6 group are required for tests of devices with objective lenses of 25 mm focal length. These can be made from brass shim stock, mounted between glass plates. The width of the lines and spaces of the various patterns are as follows, in mm.

Pattern No.	-5	Group No.	-6
1	16.00		32.00
2	14.25		28.51
3	12.70		25.40
4	11.31		22.63
5	10.08		20.16
6	8.98		17.96

⁹ The Eppley Laboratory, Inc., 12 Sheffield Ave., Newport, Rhode Island 02840, has purchased rights to this coating from the Thomas Parsons Sons Co. of England.

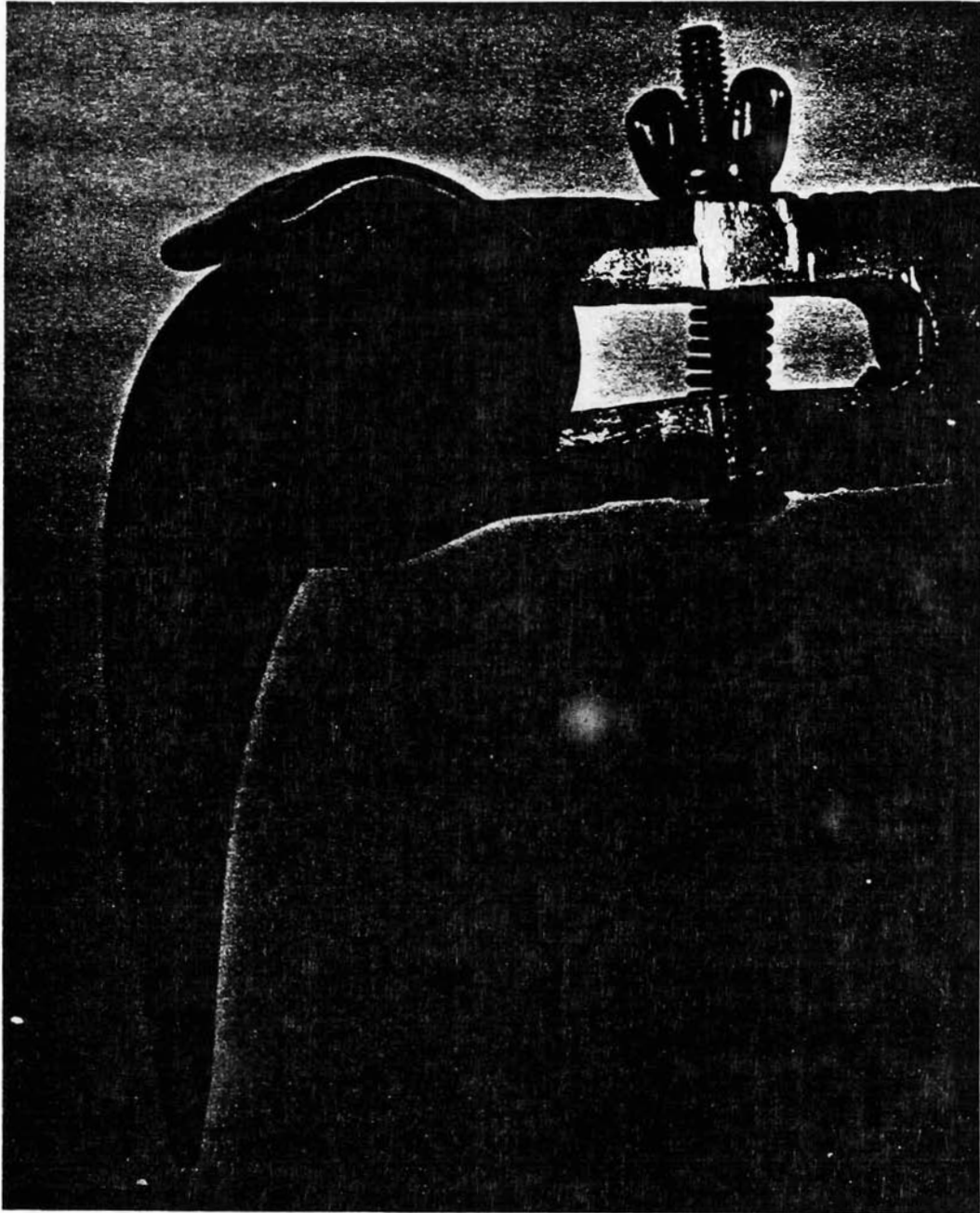

FIGURE 15. Blackbody cavity.

U.S. GOVERNMENT PRINTING OFFICE: 1975 O-587-652