

LAW ENFORCEMENT STANDARDS PROGRAM

PHYSICAL SECURITY OF DOOR ASSEMBLIES AND COMPONENTS



U.S. DEPARTMENT OF JUSTICE
Law Enforcement Assistance Administration
National Institute of Law Enforcement and Criminal Justice

LAW ENFORCEMENT STANDARDS PROGRAM

NILECJ STANDARD FOR THE PHYSICAL SECURITY OF DOOR ASSEMBLIES AND COMPONENTS

**A Voluntary National Standard Promulgated by the
National Institute of Law Enforcement and Criminal Justice.**

MAY 1976

**U.S. DEPARTMENT OF JUSTICE
Law Enforcement Assistance Administration
National Institute of Law Enforcement and Criminal Justice**

**NATIONAL INSTITUTE OF LAW ENFORCEMENT
AND CRIMINAL JUSTICE**

Gerald M. Caplan, *Director*

**LAW ENFORCEMENT ASSISTANCE
ADMINISTRATION**

Richard W. Velde, *Administrator*

Henry F. McQuade, *Deputy Administrator*

Paul K. Wormeli, *Deputy Administrator*

ACKNOWLEDGMENTS

This standard was formulated by the Law Enforcement Standards Laboratory of the National Bureau of Standards under the direction of Lawrence K. Eliason and Marshall A. Isler, Managers, Security Systems Program, and Jacob J. Diamond, Chief of LESL. Technical research was performed at the NBS Center for Building Technology under the supervision of John S. Stroik and Thomas Reichard.

NILECJ Standard for the Physical Security of Door Assemblies and Components

CONTENTS

| | Page |
|---|------|
| Foreword | v |
| 1. Purpose and Scope | 1 |
| 2. Classification | 1 |
| 3. Definitions | 2 |
| 4. Requirements | 3 |
| 4.1 General Requirements | 5 |
| 4.2 Bolt Projection and Strike Hole Size | 5 |
| 4.3 Bolt Pressure Resistance | 5 |
| 4.4 Jamb/Wall Stiffness | 5 |
| 4.5 Knob Impact Resistance | 6 |
| 4.6 Cylinder Core Tension Resistance | 6 |
| 4.7 Cylinder Tension Resistance (Class IV Only) | 6 |
| 4.8 Knob Torque Resistance | 6 |
| 4.9 Cylinder Torque Resistance (Classes III and IV Only) | 6 |
| 4.10 Cylinder Impact Resistance (Classes III and IV Only) | 6 |
| 4.11 Door Impact Resistance | 6 |
| 4.12 Hinge Pin Removal Resistance | 7 |
| 4.13 Hinge Impact Resistance | 7 |
| 4.14 Bolt Impact Resistance | 7 |
| 5. Test Methods | 7 |
| 5.1 Sampling | 7 |
| 5.2 Test Equipment | 8 |
| 5.3 Test Fixtures | 8 |
| 5.4 Sample Preparation | 13 |
| 5.5 Test Sequence | 13 |
| 5.6 Bolt Projection and Strike Hole Test | 14 |
| 5.7 Bolt Pressure Test | 14 |
| 5.8 Jamb/Wall Stiffness Test | 14 |
| 5.9 Knob Impact Test | 14 |
| 5.10 Cylinder Core Tension Test | 14 |
| 5.11 Cylinder Tension Test | 15 |
| 5.12 Knob Torque Test | 15 |
| 5.13 Cylinder Torque Test | 15 |
| 5.14 Cylinder Impact Test | 15 |
| 5.15 Door Impact Test | 16 |
| 5.16 Hinge Pin Removal Test | 16 |
| 5.17 Hinge Impact Test | 16 |
| 5.18 Bolt Impact Test | 17 |
| Appendix A--References | 18 |
| Appendix B--Test Equipment | 19 |

FOREWORD

Following a Congressional mandate¹ to develop new and improved techniques, systems, and equipment to strengthen law enforcement and criminal justice, the National Institute of Law Enforcement and Criminal Justice (NILECJ) has established the Law Enforcement Standards Laboratory (LESL) at the National Bureau of Standards. LESL's function is to conduct research that will assist law enforcement and criminal justice agencies in the selection and procurement of quality equipment.

In response to priorities established by NILECJ, LESL is (1) subjecting existing equipment to laboratory testing and evaluation and (2) conducting research leading to the development of several series of documents, including national voluntary equipment standards, user guidelines, state-of-the-art surveys, and other reports.

This document, NILECJ-STD-0306.00, Physical Security of Door Assemblies and Components, is a law enforcement equipment standard developed by LESL and approved and issued by NILECJ. Additional standards as well as other documents are being issued under the LESL program in the areas of protective equipment, communications equipment, security systems, weapons, emergency equipment, investigative aids, vehicles, and clothing.

This equipment standard is a technical document consisting of performance and other requirements together with a description of test methods. Equipment which can meet these requirements is of superior quality and is suited to the needs of law enforcement agencies. Purchasing agents can use the test methods described in this standard to determine firsthand whether a particular equipment item meets the requirements of the standard, or they may have the tests conducted on their behalf by a qualified testing laboratory. Law enforcement personnel may also reference this standard in purchase documents and require that any equipment offered for purchase meet its requirements and that this compliance be either guaranteed by the vendor or attested to by an independent testing laboratory.

The necessarily technical nature of this NILECJ standard, and its special focus as a procurement aid, make it of limited use to those who seek general guidance concerning the physical security of door assemblies or components. The NILECJ Guideline Series is designed to fill that need. We plan to issue guidelines to this as well as other law enforcement equipment as soon as possible, within the constraints of available funding and the overall NILECJ program.

The guideline documents being issued are highly readable and tutorial in nature, in contrast to the standards which are highly technical and intended for laboratory use by technical personnel. The guidelines provide, in nontechnical language, information for purchasing agents and other interested persons concerning the capabilities of equipment currently available. They may then select equipment appropriate to the performance required by their agency. Recommendations for the development of particular guidelines should be sent to us.

NILECJ standards are subjected to continuing review. Technical comments and recommended revisions are invited from all interested parties. Suggestions should be addressed to the Program Manager for Standards, National Institute of Law Enforcement and Criminal Justice, Law Enforcement Assistance Administration, U.S. Department of Justice, Washington, D.C. 20531.

Lester D. Shubin
Manager, Standards Program
National Institute of Law
Enforcement and Criminal Justice

¹Section 402 (b) of the Omnibus Crime Control and the Safe Streets Act of 1968, as amended.

NILECJ STANDARD for the PHYSICAL SECURITY OF DOOR ASSEMBLIES AND COMPONENTS

1. PURPOSE AND SCOPE

The purpose of this document is to establish performance requirements and methods of test for the resistance of door assemblies and components to forced entry.

This standard is concerned with typical entry doorways in residences and some small businesses; i.e., single, pedestrian use, hinged swinging doors. Included are requirements for both the total door assembly and individual components, such as the hinges, lock, door, jamb/strike, and jamb/wall.

This standard addresses the capability to frustrate the "opportunity" crimes committed by unskilled and semi-skilled burglars. The skilled methods of entry used to gain access to premises containing valuable property are not addressed.

2. CLASSIFICATION

For the purposes of this standard, door assemblies and components are classified by their relative resistance to forced entry, and locks are classified as type A or B on the basis of the locking mechanism. Four classes of door assemblies and components are established, from class I, with the lowest level of resistance, to class IV, with the highest level of resistance.

2.1 Security Level

2.1.1 Class I

Door assemblies and components which provide a minimum level of physical security.

2.1.2 Class II

Door assemblies and components which provide a moderate level of physical security.

2.1.3 Class III

Door assemblies and components which provide a medium level of physical security.

2.1.4 Class IV

Door assemblies and components which provide a relatively high level of physical security.

2.2 Lock Type

2.2.1 Type A

A lock which uses a single dead latch, or which uses the combination of a latch or dead latch and a dead bolt which are mechanically interconnected.

2.2.2 Type B

A lock in which the latch or dead latch is mechanically independent from the dead bolt.

3. DEFINITIONS

3.1 Bolt

A metal bar which, when actuated, is projected (or “thrown”) either horizontally or vertically into a retaining member, such as a strike plate, to prevent a door from moving or opening.

3.2 Bolt Projection (or Bolt Throw)

The distance from the edge of the door, at the bolt center line, to the furthest point on the bolt in the projected position, when subjected to end pressure.

3.3 Component

As distinguished from a part; a subassembly which combines with other components to make up a total door assembly. The prime components of a door assembly include: door, lock, hinges, jamb/wall, jamb/strike, and wall.

3.4 Cylinder

The cylindrical subassembly of a lock, containing the cylinder core, tumbler mechanism, and the keyway. A double cylinder lock is one which has a key-actuated cylinder on both the exterior and interior of the door.

3.5 Cylinder Core (or Cylinder Plug)

The central part of a cylinder, containing the keyway, which is rotated by the key to operate the lock mechanism.

3.6 Dead Bolt

A lock bolt which does not have a spring action as opposed to a latch bolt which does. The bolt must be actuated by a key and/or a knob or thumb turn and when projected becomes locked against return by end pressure.

3.7 Dead Latch (or Dead Locking Latch Bolt)

A spring-actuated latch bolt having a bevelled end and incorporating a plunger which, when depressed, automatically locks the projected latch bolt against return by end pressure.

3.8 Door Assembly

A unit composed of a group of parts or components which make up a closure for a passageway through a wall. For the purposes of this standard, a door assembly consists of the following parts: door; hinges; locking device or devices; operation contacts (such as handles, knobs, push plates); miscellaneous hardware and closures; the frame, including the head and jambs plus the anchorage devices to the surrounding wall; and a portion of the surrounding wall extending 90 cm (36 in.) from each side of the jambs and 40 cm (16 in.) above the head.

3.9 Jamb

The vertical members of door frame (e.g., those fixed members to which the door is secured).

3.10 Jamb/Strike

That component of a door assembly which receives and holds secure the extended lock bolt; the strike and jamb, used together, are considered a unit.

3.11 Jamb/Wall

That component of a door assembly to which a door is attached and secured by means of the hinges; the wall and jamb, used together, are considered a unit.

3.12 Key-In-Knob

A lock having the key cylinder and other lock mechanisms such as a push or turn button contained in the knobs.

3.13 Latch (or Latch Bolt)

A bevelled, spring-actuated bolt, which may or may not have a dead locking device.

3.14 Lock (or Lock Set)

A keyed device (complete with cylinder, latch or dead bolt mechanism, and trim such as knobs, levers, thumb turns, escutcheons, etc.) for securing a door in a closed position against forced entry. For the purposes of this standard, a lock does not include the strike plate.

3.15 Part

As distinguished from component; a unit (or subassembly) which combines with other units to make up a component.

3.16 Strike

A metal plate attached to, or mortised into a door jamb to receive and to hold a projected latch bolt and/or dead bolt in order to secure the door to the jamb.

4. REQUIREMENTS

The door assembly and component requirements are summarized in table 1.

Door Assembly and Component Requirements

| Door Assembly Tests | Test Method Paragraph | Component Test | Measured Parameter | Requirement | | | |
|-----------------------------|-----------------------|-----------------------|--|-----------------------------|--|--|---|
| | | | | Class I | Class II | Class III | Class IV |
| Bolt Projection Strike Hole | 5.6 | Lock | Projection Size | 14.3 mm (9/16 in) * | 14.3 mm (9/16 in) * | 17.5 mm (11/16 in) * | 17.5 mm (11/16 in) * |
| Bolt Pressure | 5.7 | Lock | Resistance | 670 N (150 lbf) | 670 N (150 lbf) | 670 N (150 lbf) | 670 N (150 lbf) |
| Jamb/Wall Stiffness | 5.8 | Jamb/Wall | Force to spread | 6,000 N (1,350 lbf) | 8,000 N (1,800 lbf) | 16,000 N (3,600 lbf) | 22,000 N (4,950 lbf) |
| | | | Increase in lock-front to strike space | 9.5 mm (3/8 in) | 9.5 mm (3/8 in) | 13 mm (1/2 in) | 13 mm (1/2 in) |
| Knob Impact** | 5.9 | Lock | Resistance - 100 Joule (74 ft-lbf) impact | One blow | Two blows | Five blows | Ten blows |
| Cylinder Core Tension | 5.10 | Lock | Resistance | 1,300 N (290 lbf) | 4,800 N (1,080 lbf) | 11,000 N (2,470 lbf) | 11,000 N (2,470 lbf) |
| Cylinder Body Tension | 5.11 | Lock | Resistance | --- | --- | --- | 16,000 N (3,600 lbf) |
| Knob Torque** | 5.12 | Lock | Resistance | 25 Nm (18.5 lbf-ft) | 50 Nm (37 lbf-ft) | 110 Nm (81 lbf-ft) | 160 Nm (118 lbf-ft) |
| Cylinder Torque*** | 5.13 | Lock | Resistance | --- | --- | 100 Nm (81 lbf-ft) | 160 Nm (118 lbf-ft) |
| Cylinder Impact*** | 5.14 | Lock | Resistance - 100 J (74 ft-lbf) impact | --- | --- | Five blows | Ten blows |
| Door Impact | 5.15 | Door | Impact resistance at center and panel | 2 blows of 80 J (59 ft lbf) | Class I requirements plus 2 blows of 120 J (89 ft lbf) | Class II requirements plus 2 blows of 160 J (118 ft lbf) | Class III requirements plus 2 blows of 200 (148 ft lbf) |
| | | | Impact resistance of glazing—100 J (74 ft-lbf) | One blow | Two blows | Five blows | Ten blows |
| Hinge Pin Removal**** | 5.16 | Hinge | Resistance | 225 N (50 lbf) | 225 N (50 lbf) | 900 N (200 lbf) | 900 N (200 lbf) |
| Hinge Impact | 5.17 | Door Hinge Jamb/Wall | Impact resistance at hinge | 2 blows of 80 J (59 ft lbf) | Class I requirements plus 2 blows of 120 J (89 ft lbf) | Class II requirements plus 2 blows of 160 J (118 ft lbf) | Class III requirements plus 2 blows of 200 (148 ft lbf) |
| Bolt Impact | 5.18 | Lock Door Jamb/Strike | Impact resistance at bolt | 2 blows of 80 J (59 ft lbf) | Class I requirements plus 2 blows of 120 J (89 ft lbf) | Class II requirements plus 2 blows of 160 J (118 ft lbf) | Class III requirements plus 2 blows of 200 (148 ft lbf) |

*Dead latch plunger must not enter strike hole with latch bolt.

**Applies to type A locks only.

***Does not apply to key-in-knob locks.

****Applies to out-swinging doors only.

4.1 General Requirements

4.1.1 Failure Criteria

An item shall fail a test if, at any time during the test, the tester can open the door from the outside by pushing or pulling on it, turning the knob, manipulating an exposed lock component, and/or by reaching through damaged portions of the door and unlocking it from the inside; can enter through damaged portions of the door even though it might not be possible to open the door; or if the dead latch or dead bolt can be depressed by a static load applied by hand.

4.1.2 Disassembly

Door assemblies and components shall incorporate no screw, bolt, nail, staple, or other mechanical fastener which is accessible from the outside, and whose removal would permit entry by disassembly.

4.1.3 Lock Type

Door assemblies and locks tested as components shall meet the requirements of paragraph 4.5, unless it is determined by inspection that the locks are of type B.

4.1.4 Classification

A door assembly meets the requirements for a specific security classification if neither of the two sample assemblies fail any of the required tests for that class. This classification holds only when the wall construction and the door assembly installation are identical in the use and the test situation, or are demonstrated to be equivalent.

A component meets the requirements for a specific security classification if neither of the two samples fail any of the required tests for that class.

Door assemblies constructed from components tested and classified in accordance with this standard shall be considered to provide a security classification equal to that of the component having the lowest classification level, providing that the wall construction and jamb and strike and hinge installations are identical in the use and the test situation, or are demonstrated to be equivalent.

4.2 Bolt Projection and Strike Hole Size

When type A and B locks, as components, are tested in accordance with paragraph 5.6, the dead bolt or dead latch projection shall be a minimum of 14.3 mm (9/16 in) for classes I and II, and 17.5 mm (11/16 in) for classes III and IV.

For locks incorporating dead latches, the size of the latch retaining hole in the strike shall be such that it shall not be possible for both the dead latch and dead latch plunger to enter the hole together, when the latch is fully extended.

4.3 Bolt Pressure Resistance

When type A and B locks, as components, and locks which are components of door assemblies are tested in accordance with paragraph 5.7, the force required to depress the dead latch and/or dead bolt from the locked and projected position shall be a minimum of 670 newtons (150 pounds-force).

4.4 Jamb/Wall Stiffness

When jamb/walls, as components, and door assemblies are tested in accordance with paragraph 5.8, the force required to increase the lock front-to-strike spacing by an additional 9.5 mm (3/8 in) for classes I and II and 13 mm (1/2 in) for classes III and IV shall be a minimum of 6,000 newtons (N) [1,350 pounds-force (lbf)] for class I; 8,000 N (1,800 lbf) for class II; 16,000 N (3,600 lbf) for class III; and 22,000 N (4,950 lbf) for class IV.

4.5 Knob Impact Resistance

When type A locks, as components, and door assemblies using type A locks are tested in accordance with paragraph 5.9, it shall not be possible to open the door after the outside knob has been subjected to one blow of 100 joules (J) [74 foot pounds-force (ft-lbf)] for class I; two blows of 100 J (74 ft-lbf) for class II; five blows of 100 J (74 ft-lbf) for class III; and ten blows of 100 J (74 ft-lbf) for class IV.

4.6 Cylinder Core Tension Resistance

When type A and B locks, as components, and door assemblies are tested in accordance with paragraph 5.10, it shall not be possible to open the door after the cylinder core of the lock has been subjected to a tensile force of 1,300 newtons (N) [290 pounds-force (lbf)] for class I; 4,800 N (1,080 lbf) for class II; and 11,000 N (2,470 lbf) for classes III and IV.

4.7 Cylinder Tension Resistance (Class IV Only)

When type A and B locks, as components, and door assemblies are tested in accordance with paragraph 5.11, it shall not be possible to open the door after the lock cylinder has been subjected to a tensile load of 16,000 newtons (3,600 pounds-force).

4.8 Knob Torque Resistance

When type A locks, as components, and door assemblies using type A locks are tested in accordance with paragraph 5.12, it shall not be possible to open the door after the outside knob has been subjected to a torque of 25 newton meters (Nm) [18.5 pound force-feet (lbf-ft)] for class I; 50 Nm (37 lbf-ft) for class II; 110 Nm (81 lbf-ft) for class III; and 160 Nm (118 lbf-ft) for class IV. This requirement does not apply to locks in which the outside knob is free to spin when locked.

4.9 Cylinder Torque Resistance (Classes III and IV Only)

When type A and B locks, as components, and door assemblies are tested in accordance with paragraph 5.13, it shall not be possible to open the door after the cylinder lock has been subject to a torque of 110 newton meters (Nm) [81 pound force-feet (lbf-ft)] for class III and 160 Nm (118 lbf-ft) for class IV. This requirement does not apply to key-in-knob locks, or a lock in which it is not possible to apply to torque to the cylinder body by gripping its edge.

4.10 Cylinder Impact Resistance (Classes III and IV Only)

When type A and B locks, as components, and door assemblies are tested in accordance with paragraph 5.14, it shall not be possible to open the door after the cylinder core or body has been subjected to five blows of 100 joules (J) (74 ft-lbf) for Class III and ten blows of 100 J (74 ft-lbf) for class IV. This requirement does not apply to key-in-knob locks.

4.11 Door Impact Resistance

When doors, as components, and door assemblies are tested in accordance with paragraph 5.15, it shall not be possible to open the door following impacts at each required test location of two blows of 80 joules (J) [59 foot pounds-force (ft-lbf)] for class I; the class I requirement plus two blows of 120 J (89 ft-lbf) for class II; the class II requirement plus two blows of 160 J (118 ft-lbf) for class III; and the class III requirement plus two blows of 200 J (148 ft-lbf) for class IV.

When the door has one or more glazing panels with the smallest side larger than 10 cm (4 in) or the door assembly has such a panel in the door or adjacent to the door (side light), it shall, in addition, not be possible to open the door after the glazing panel closest to the lock has been subjected to one blow of 100 joules (74 foot pounds-force) for class I, two blows for class II, five blows for class III, and ten blows for class IV. This requirement does not apply to class I door components or door assemblies in which the glazing panel is located a distance of 75 cm (30 in) or more from the lock.

4.12 Hinge Pin Removal Resistance

When hinges having exposed pins, intended for use with out-swinging doors, and out-swinging door assemblies incorporating such hinges are tested in accordance with paragraph 5.16, the hinge pins shall resist without removal a tensile load of 225 newtons (N) [50 pounds-force (lbf)] for classes I and II, and 900 N (200 lbf) for classes III and IV.

If the hinges fail to meet the above requirement, but incorporate mechanical interlocks between the leaves of the hinges in the closed position, and meet the requirements of paragraph 4.13 with the hinge pins removed during the test, they shall be considered to have met the requirements of paragraph 4.12.

4.13 Hinge Impact Resistance

When hinges, doors, and jamb/walls, as components, and door assemblies are tested in accordance with paragraph 5.17, it shall not be possible to open the door following two blows of 80 joules (J) [59 foot pounds-force (ft-lbf)] for class I; the class I requirement plus two blows of 120 J (89 ft-lbf) for class II; the class II requirement plus two blows of 160 J (118 ft-lbf) for class III; and the class III requirement plus two blows of 200 J (148 ft-lbf) for class IV.

4.14 Bolt Impact Resistance

When type A and B locks, doors, and jamb/strikes, as components, and door assemblies are tested in accordance with paragraph 5.18, it shall not be possible to open the door following two blows of 80 joules (J) [59 foot pounds-force (ft-lbf)] for class I; the class I requirement plus two blows of 120 J (89 ft-lbf) for class II; the class II requirement plus two blows of 160 J (118 ft-lbf) for class III; and the class III requirement plus two blows of 200 J (148 ft-lbf) for class IV.

5. TEST METHODS

5.1 Sampling

5.1.1 General

Specimens shall be selected at random for test. Complete manufacturer or fabricator installation instructions and full size templates for all items of hardware shall be included.

5.1.2 Door Assemblies

The door assembly sample shall consist of two assemblies of identical components, with additional lock sets and other components as required for the destructive tests, the wall section of which has been fabricated in compliance with the building construction specifications for that door assembly. See table 2.

5.1.3 Components

The component sample shall consist of duplicate specimens, with additional duplicate specimens as required for the destructive tests. See table 2.

5.2 Test Equipment

5.2.1 Door Ram

The door ram shall be a pendulum system with a steel weight capable of delivering horizontal impacts of up to 200 J (148 ft-lbf). The striking end of the weight shall be hemispherical and have a diameter of approximately 15 cm (6 in).

5.2.2 Component Ram

The component ram shall be a pendulum system with a steel weight capable of delivering horizontal impacts of up to 100 J (74 ft-lbf). The striking end of the weight shall have an impact nose approximately 32 mm (1-1/4 in) in diameter.

5.2.3 Vertical Impactor

The vertical impactor shall employ a steel weight and be capable of delivering vertical (downward) impacts of up to 100 J (74 ft-lbf) to a door knob installed in a door assembly.

5.2.4 Torque Applicator

The portable torque applicator shall be capable of delivering and measuring up to 160 Nm (118 lbf-ft) of torque to both door knobs and lock cylinders. The torque loading adapters shall be designed to grip the knobs and cylinders.

5.2.5 Tension Loading Device

The tension loading device shall be capable of delivering and measuring compressive forces of up to 900 N (200 lbf).

5.2.6 Compression Loading Device

The compression loading device shall be capable of delivering and measuring compressive forces of up to 900 N (200 lbf).

5.2.7 Jamb Spreading Device

The jamb spreading device shall be capable of delivering to door jambs and measuring spreading forces of up to 22,000 N (4,950 lbf) with a means of measuring up to 13 mm (½ in) of spread in the door opening. The device shall have on each end either a load bearing plate or pressure foot which provides a minimum contact surface of 40 x 120 mm (1½ x 5 in).

5.2.8 Instrument Accuracy

The tension loading and jamb spreading devices shall have a combined calibration and reading error no greater than 200 N (45 lbf). The compression loading device shall have a combined calibration and reading error of no greater than 40 N (11 lbf). The torquemeter shall have a combined error no greater than 3.4 Nm (2.5 lbf-ft). The impact energy of each pendulum system shall be controlled to within one percent. Suitable test equipment is described in appendix B.

5.3 Test Fixtures

5.3.1 Wall Support Fixture

The fixture for door assembly tests shall consist of framing members, providing rigid, transverse restraint along all four edges of the assembly. The restraint provided by this fixture shall simulate the rigidity normally provided to a door assembly in a building by the ceiling, floor, and walls. Figure 1 shows a suitable wall support fixture.

TABLE 2. Test Sequence

| TEST | DOOR ASSEMBLY TEST SEQUENCE | | | | | | | | COMPONENT TEST SEQUENCE | | | | | | | | | | | | | | | | | | | | | | | | | | | |
|---|-----------------------------|----|-----|-----|-------------|----|-----|----|-------------------------|----|-----|-----|-------------|----|-----|----|-------|----|-----|----|-------|----|-----|----|-----------|----|-----|----|-------------|----|-----|----|---|---|---|---|
| | Type A Lock | | | | Type B Lock | | | | Type A Lock | | | | Type B Lock | | | | Door | | | | Hinge | | | | Jamb/Wall | | | | Jamb/Strike | | | | | | | |
| | Class | | | | Class | | | | Class | | | | Class | | | | Class | | | | Class | | | | Class | | | | | | | | | | | |
| | I | II | III | IV | I | II | III | IV | I | II | III | IV | I | II | III | IV | I | II | III | IV | I | II | III | IV | I | II | III | IV | I | II | III | IV | | | | |
| Bolt Projection (5.6) Strike Hole Size | 1 | 1 | 1 | 1 | 1 | 1 | 1 | 1 | 1 | 1 | 1 | 1 | 1 | 1 | 1 | 1 | | | | | | | | | | | | | | | | | | | | |
| Bolt Pressure (5.7) | 2 | 2 | 2 | 2 | 2 | 2 | 2 | 2 | 2 | 2 | 2 | 2 | 2 | 2 | 2 | 2 | | | | | | | | | | | | | | | | | | | | |
| Jamb/Wall Stiffness Test (5.8) | 3* | 3* | 3* | 3* | 3* | 3* | 3* | 3* | | | | | | | | | | | | | | | | | 1 | 1 | 1 | 1 | | | | | | | | |
| Knob Impact (5.9) | 4 | 4 | 4 | 4 | | | | | 3* | 3* | 3* | 3* | | | | | | | | | | | | | | | | | | | | | | | | |
| Cylinder Core Tension (5.10) | 5* | 5* | 5* | 5* | 4* | 4* | 4* | 4* | 4* | 4* | 4* | 4* | 3* | 3* | 3* | 3* | | | | | | | | | | | | | | | | | | | | |
| Cylinder Tension (5.11) | | | | 6* | | | | 5* | | | | 5* | | | | 4* | | | | | | | | | | | | | | | | | | | | |
| Knob Torque (5.12) | * | 6* | 6* | 7* | | | | | 5* | 5* | 5* | 6* | | | | | | | | | | | | | | | | | | | | | | | | |
| Cylinder Torque (5.13) | | | 7*† | 8*† | | | 5* | 6* | | | 6*† | 7*† | | | 4* | 5* | | | | | | | | | | | | | | | | | | | | |
| Cylinder Impact (5.14) | | | 8*† | 9*† | | | 6* | 7* | | | 7*† | 8*† | | | 5* | 6* | | | | | | | | | | | | | | | | | | | | |
| Door Impact (5.15) | 7* | 7* | 9* | 10* | | | 7* | 8* | | | | | | | | | 1 | 1 | 1 | 1 | | | | | | | | | | | | | | | | |
| Hinge Pin Removal** (5.16) | 8 | 8 | 10 | 11 | | | 8 | 9 | | | | | | | | | | | | | 1 | 1 | 1 | 1 | | | | | | | | | | | | |
| Hinge Impact*** | 9 | 9 | 11 | 12 | | | 9 | 10 | | | | | | | | | 2 | 2 | 2 | 2 | 2 | 2 | 2 | 2 | 2 | 2 | 2 | 2 | | | | | | | | |
| Bolt Impact (5.18) | 10 | 10 | 12 | 13 | | | 10 | 11 | | | 8* | 9* | | | 6* | 7* | 3 | | | | 3 | 3 | 3 | | | | | | | | | | 1 | 1 | 1 | 1 |

6

*Replace lock used in previous test(s) with a new duplicate lock.

**Applies to out-swinging doors only.

***If a component is structurally weakened, replace it before the next test.

†Does not apply to key-in-knob locks.

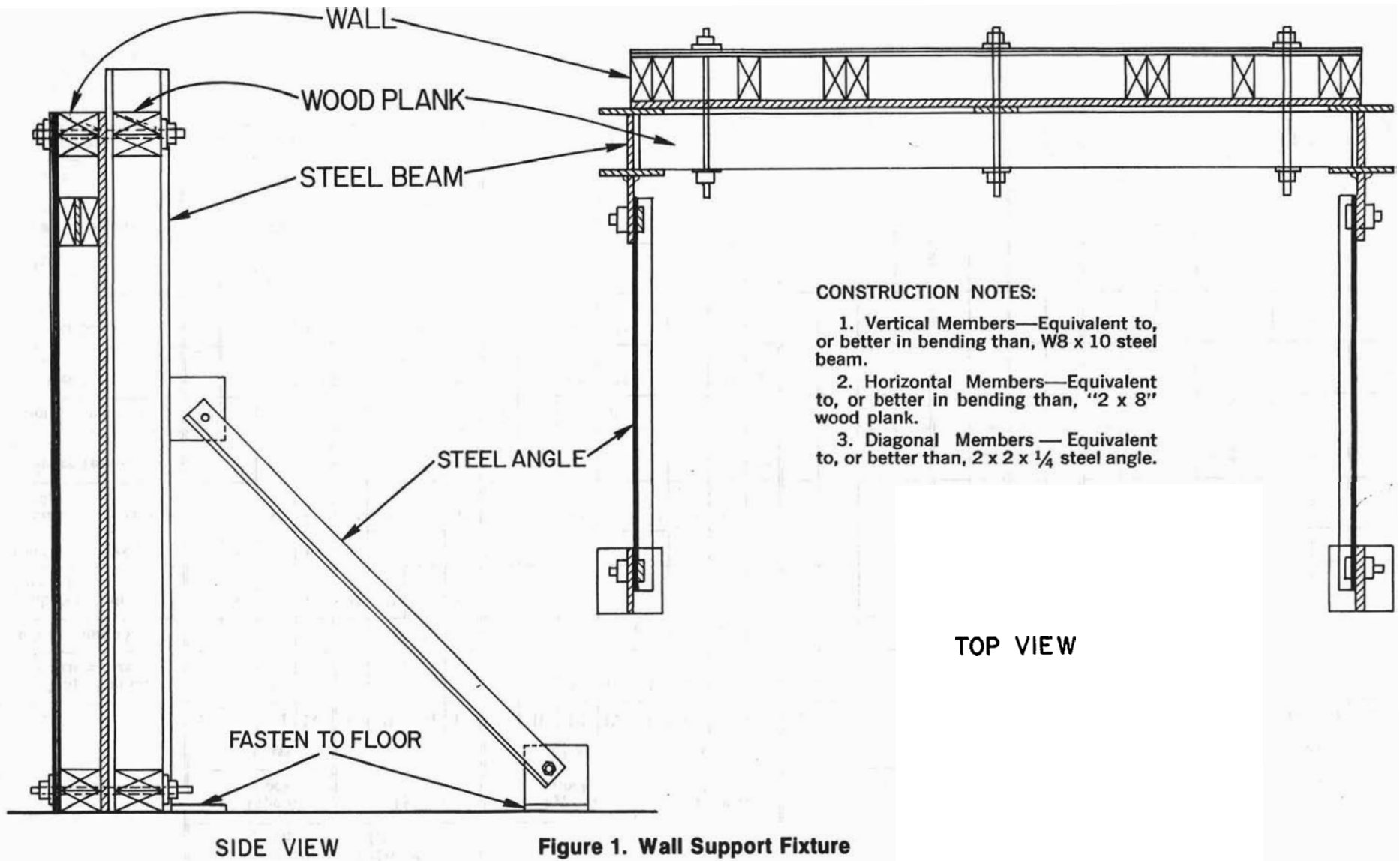

5.3.2 Door, Door Jamb, Hinge, and Lock Strike Component Fixture

The test fixture for doors, door jambs, hinges, and lock strikes as components shall consist of a vertical wall section constructed from 2 x 4 studs, with a rough entry door opening, and shall be covered with ½ inch exterior grade plywood sheathing on the exterior and ½ inch gypsum board on the interior. It shall be constructed as shown in figure 2, and shall be secured to the wall support fixture (at the sides and top) and to the laboratory floor. For tests of doors, lock strikes, and hinges as components, the fixture wall section shall also include a door jamb.

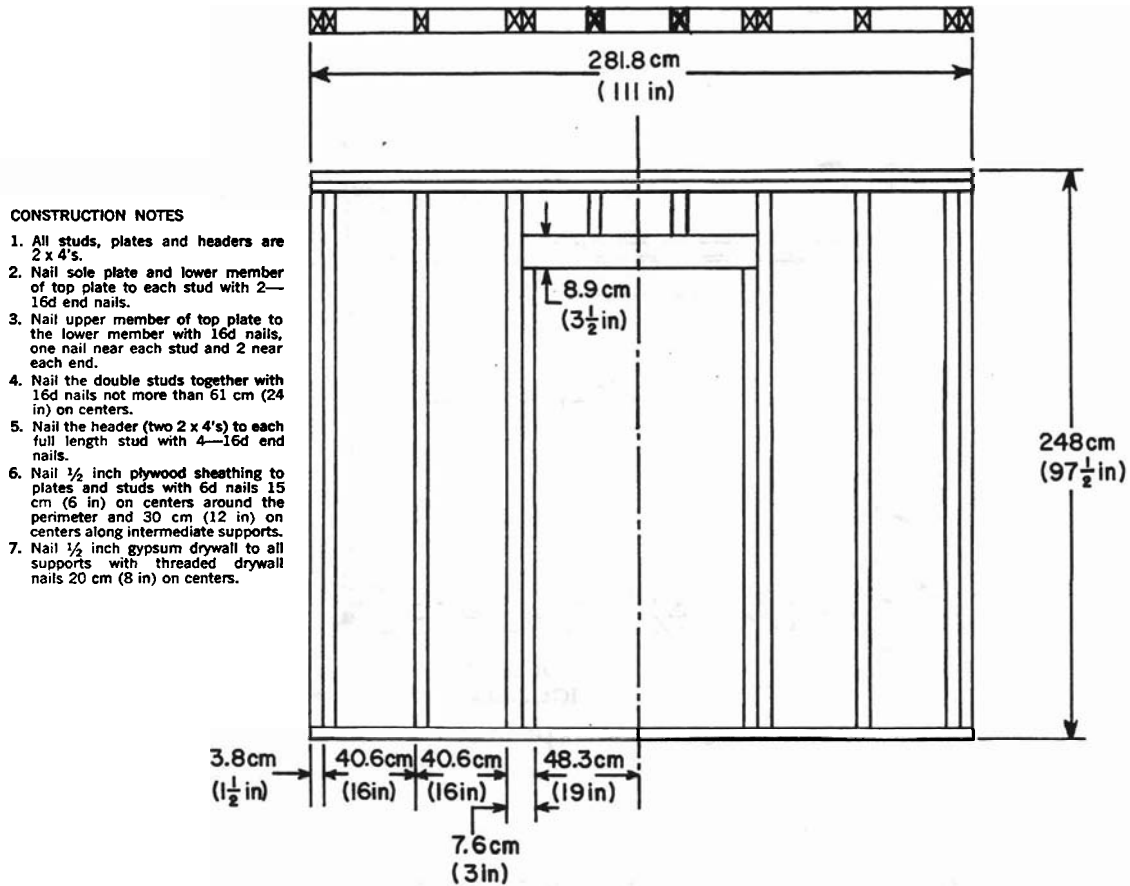

Figure 2. Door, Door Jamb, Hinge, and Lock Strike Component Fixture

5.3.3 Lock Component Fixture

The test fixture for locks as components shall consist of a small door assembly, as shown in figure 3. The frame shall be fabricated from steel angle and plate at least 3 mm (1/8 in) thick. The door shall be 61 cm (24 in) square and 4.4 cm (1-3/4 in) thick, made by bonding three pieces of plywood together. A steel angle shall be bolted to the hinge edge of the door, and a steel strike plate shall be bolted to the frame at the lock position of the door. The door shall be hinged with two 11.5 cm (4-½ in) steel butt hinges.

5.3.4 Bolt Pressure Test Fixture

The fixture for bolt pressure tests shall consist of a vertical panel fabricated from wood attached to a stable horizontal base. The top edge of the panel shall be parallel to the bottom surface of the base. The panel shall be about 4.4 cm (1-3/4 in) thick and the top edge shall be prepared to permit the lock set which is being tested to be mounted in the panel in accordance with the manufacturer's instructions. See figure 4.

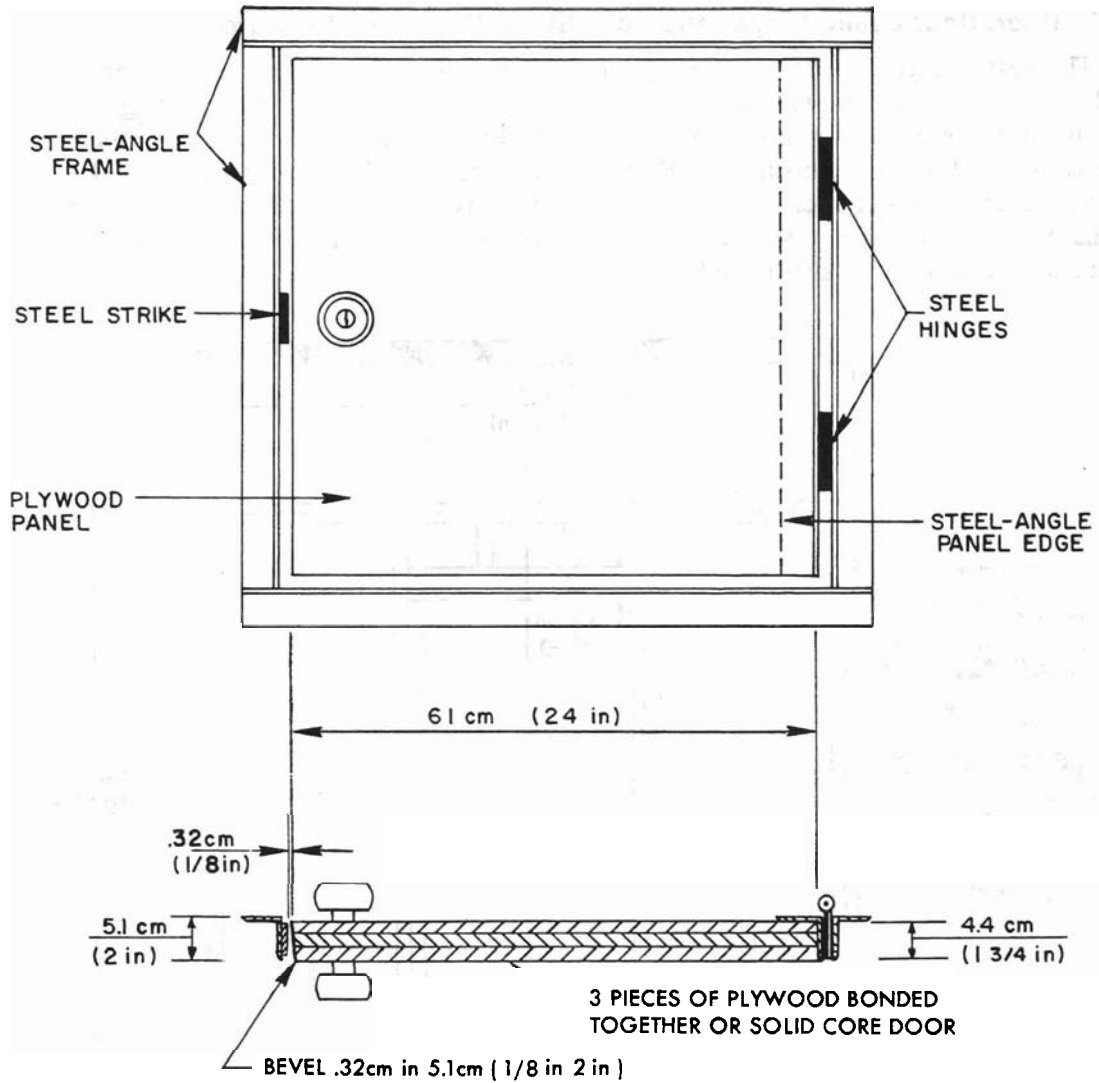

Notes: DOOR PANEL

- 3 PIECES OF PLYWOOD [61cm (24in) SQUARE] BONDED TOGETHER
1 PIECE, 1.9cm THICK (3/4in), BETWEEN 2 PIECES, EACH 1.3cm THICK (1/2in)

OR

GLUED BLOCK CORE DOOR WITH PREMIUM OR GOOD GRADE
HARDWOOD VENEER (NWMA I.S. 1-74)

- STEEL ANGLE BOLTED TO HINGE EDGE

STEEL ANGLE FRAME AND PANEL EDGE

5.1cm×5.1cm×0.3cm THICK (2in×2in×1/8in)

Figure 3. Lock Component Fixture

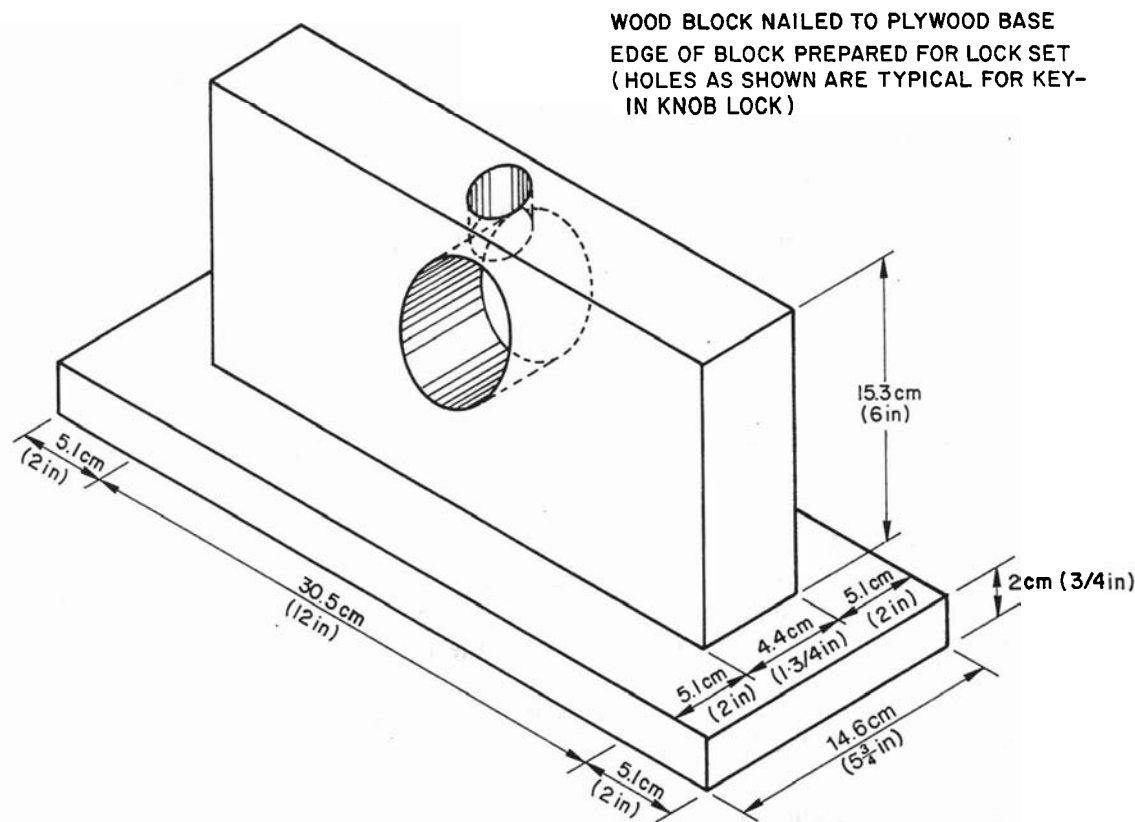

Figure 4. Bolt Pressure Test Fixture

5.4 Sample Preparation

To test a door assembly, follow the building construction specifications and fabricate a wall section which duplicates that in the actual structure for which physical security is to be evaluated. Attach this to the wall support fixture (5.3.1), and install the remaining components in accordance with the manufacturers' instructions, using the templates and recommendations furnished with the assembly and/or components. Install the door so that it swings in, away from the working area, except when testing an out-swinging door.

Prepare doors and door jambs for the installation of locks and hinges in conformance with the applicable ANSI Standard A115 (ref. 1). Install locks with a lock front-to-strike spacing of 3.2 ± 0.4 mm ($1/8 \pm 1/64$ in). In the absence of construction specifications, make the clearances on the hinge side and top of the door 3.2 ± 0.4 mm ($1/8 \pm 1/64$ in).

To test doors, door jambs, hinges, and jamb/strikes as components, install them in the component test fixture described in paragraph 5.3.2. Except when testing hinges, hinge the door with 1- $\frac{1}{2}$ pair of 11.5 cm (4- $\frac{1}{2}$ in) steel butt hinges, and fit it at the normal lock point with a bolt having sufficient strength and stiffness to prevent it from failing during test.

To test locks as components, install them in the component test fixture described in paragraph 5.3.3

5.5 Test Sequence

Perform tests for each of the duplicate specimens in the same sequence as presented below, as appropriate for the item under test, using new components for each destructive test (see table 2).

5.6 Bolt Projection and Strike Hole Test

Apply finger pressure to the end of the projected dead bolt or the dead-locked, fully extended dead latch and measure the distance from the lock front surface to the furthest point on the bolt or latch.

If the lock incorporates a dead latch, place the strike over the dead latch to determine whether it is possible for both the latch and the latch plunger to simultaneously enter the hole in the strike when the latch is fully extended and the lock front-to-strike distance is 3.2 mm (1/8 in).

5.7 Bolt Pressure Test

Mount the lock in the test fixture described in paragraph 5.3.4 and extend the dead bolt and/or dead latch to the fully projected position. If the lock incorporates a dead latch plunger, attach a spacer [7.9 mm (5/16 in) thick] to the lock front. Allow the dead latch plunger to project flush with the top of the spacer, and hold it in that position with a piece of tape or by other suitable means.

Place the lock, in the test fixture, in a compression testing machine, or mount it on a firm, level surface with the compression loading device (5.2.6) directly above it, the loading face parallel to the lock front, and the axis of the hydraulic ram perpendicular to the lock front. Apply an increasing compressive load to the end of the lock bolt. Note the force required to depress the dead bolt or dead latch to within 7.9 mm (5/16 in) of the top surface of the lock front.

5.8 Jamb/Wall Stiffness Test

Prepare the test specimen in accordance with paragraph 5.4. and lock the door in the closed position. Position the jamb spreading device (paragraph 5.2.7) between the door jambs, at lock height. Apply increasing force, to a maximum of 22,000 newtons (4950 pounds force), and measure the force required to increase the space between the lock front and strike by an additional 9.5 mm (3/8 in) or 13 mm (½ in) as required. While the required load is being applied, try to open the door (paragraph 4.1.1).

5.9 Knob Impact Test

Prepare the test specimen in accordance with paragraph 5.4 and lock the door in the closed position. Position the vertical impactor (paragraph 5.2.3) so that the pendulum arm is horizontal when the striking weight contacts the top of the door knob, and its center of gravity is in the vertical center-line through the knob. Raise the weight to the height necessary to deliver the required impact and release it. Deliver the required number of impacts to the knob. After each impact, attempt to open the door by turning the knob, and if the knob is broken off, by manipulating the exposed lock mechanism by hand or with the aid of a screwdriver.

With the door open, and the dead bolt or dead latch in the projected, locked position, attempt to depress the latch or dead bolt by applying hand pressure to its end. The dead latch plunger, if present, should be allowed to project 7.9 mm (5/16 in).

5.10 Cylinder Core Tension Test

Prepare the test specimen in accordance with paragraph 5.4 and lock the door in the closed position. Drill a hole in the cylinder core using a number 21 drill, adjacent to the keyway, to a minimum depth of 13 mm (½ in). Tap this hole with a 10-32 thread. Attach the tension loading device (paragraph 5.2.5) to a rigid load bearing support in front of the cylinder, and align the pulling axis with that of the hole in the cylinder. Attach the tension loading adapter (figure B-12) to the cylinder with a 10-32 hardened cap screw fully threaded into the tapped hole. Connect the tension loading device to

the adapter, and apply the required tensile force to the cylinder. Following this test, release the load and attempt to open the door by manipulating any exposed lock mechanism by hand or with the aid of a screwdriver. Test the dead latch or dead bolt for end pressure resistance as in paragraph 5.9.

5.11 Cylinder Tension Test

Prepare the test specimen in accordance with paragraph 5.4 and lock the door in the closed position. Drill a hole in the cylinder body using a number 3 drill, near the center of the cylinder face, to a minimum depth of 13 mm ($\frac{1}{2}$ in). If the lock is constructed such that only the cylinder core is exposed, drill through the material covering the face of the cylinder body, into the cylinder. Tap this hole with a 1/4-28 thread. Attach the tension loading device (paragraph 5.2.5) to a rigid bearing support in front of the cylinder, and align the pulling axis with that of the hole in the cylinder. Attach the tension loading adapter (figure B-12) to the cylinder with a 1/4-28 hardened cap screw fully threaded into the tapped hole. Connect the tension loading device to the adapter, and apply the required tensile force to the cylinder. Following this test, release the load and attempt to open the door by manipulating any exposed lock mechanism by hand or with the aid of a screwdriver. Test the dead latch or dead bolt for end pressure resistance as in paragraph 5.9.

5.12 Knob Torque Test

Prepare the test specimen in accordance with paragraph 5.4 and lock the door in the closed position. Attach the torque loading adapter to the knob and connect the torque applicator to it (paragraph 5.2.4). Alternately subject the knob to the required torque in both the clockwise and counter-clockwise directions, applying the torque as rapidly as possible. Inspect the lock to determine whether the bolt is retracted from the strike when the torque is applied. If the knob is broken off, attempt to open the door by manipulating the lock mechanism by hand or with the aid of a screwdriver. Test the dead bolt or dead latch for end pressure resistance as in paragraph 5.9.

5.13 Cylinder Torque Test

Prepare the test specimen in accordance with paragraph 5.4 and lock the door in the closed position. Use the cylinder torque adapter (figure B-10) as a template and drill three 1/8 inch holes into the cylinder to a minimum depth of 13 mm ($\frac{1}{2}$ in). Align the holes in the cylinder torque adapter with those in the cylinder, insert a 25 mm (1 in) length of 1/8 inch drill rod as far as possible into each hole and connect the torque applicator (paragraph 5.2.4) to the adapter. Alternately subject the cylinder to the required torque in both the clockwise and counter-clockwise directions, applying the torque as rapidly as possible. Inspect the lock to determine whether the bolt is withdrawn from the strike when the torque is applied. If the cylinder is loose, attempt to remove it and to open the door by manipulating the lock mechanism by hand or with the aid of a screwdriver. Test the dead bolt or dead latch for end pressure resistance as in paragraph 5.9.

5.14 Cylinder Impact Test

Prepare the test specimen in accordance with paragraph 5.4 and lock the door in the closed position. Position the component ram pendulum weight (paragraph 5.2.2) so that, at rest, its axis is horizontal and coincides with the major axis of the cylinder and its striking nose just touches the face of the cylinder. Pull back the pendulum weight to the height necessary to produce a 100 joule (74 foot pounds-force) impact and release it. Repeat this to deliver the required number of impacts. After each impact, attempt to

remove the cylinder or core and to open the door by manipulating the lock mechanism hand or with the aid of a screwdriver. Test the dead bolt or dead latch for end pressure resistance as in paragraph 5.9.

5.15 Door Impact Test

Prepare the test specimen in accordance with paragraph 5.4 and lock the door in the closed position. Set up the door ram pendulum weight (paragraph 5.2.1) so that its axis is horizontal, and perpendicular to the face of the door at a point defined by the intersection of the vertical center line of the door and a line from the center of the bolt to the center of the mid-height hinge (or the mid point between hinges, when the door is hung with two hinges).

Attach to the door, centered on the impact point, a rigid foamed polystyrene impact buffer which has a diameter of 15 cm (6 in), a thickness of 5 cm (2 in), and a density of 32 kg/m³ (2 lbs/ft³). Position the door ram such that its striking nose just touches the surface of the buffer when at rest. Pull back the pendulum weight to the height necessary to produce the required impact, and release it. Subject the door to two impacts at each required impact level, attaching a new buffer for each impact. If the door is forced open by the test, the door specimen fails the test. If the door is broken, attempt to reach through the opening and open the door by unlocking it from the inside.

If the door has one or more recessed panels, subject the one closest to the lock to two impacts at each required impact level. Locate the impact point on the corner of the panel closest to the lock, 7.5 cm (3 in) in from the vertical and horizontal edges of the panel. Perform the test as described above, attaching a new impact buffer for each impact. If the panel is broken, attempt to reach through the opening and open the door by unlocking it from the inside.

To test glazing panels, set up the component ram pendulum weight (paragraph 5.2.2) so that, at rest, its striking nose just touches the front surface of the panel at a point 4 cm (1.6 in) from the horizontal and vertical edges of the panel closest to the lock. Pull back the pendulum weight to the height necessary to produce the required impact, and release it. Repeat this to deliver the required number of impacts. If the panel is broken, attempt to reach through the opening and open the door by unlocking it from the inside.

Following the door impact test, inspect the door to determine whether there is enough damage to invalidate the subsequent tests (paragraphs 5.17 and 5.18); if there is, replace it.

5.16 Hinge Pin Removal Test

If the hinge is part of a door assembly, remove it from the assembly. Drill a hole into the end of the exposed hinge pin with a number 21 drill, centered on and aligned with the axis of the pin, to a depth of 13 mm (½ in). Tap the hole with a 10-32 tap, and attach the tension loading adapter (figure B-12) to it with a hardened cap screw. Clamp one leaf of the hinge to a vice. Attach the tension loading device (paragraph 5.2.5) to a rigid load bearing support and align the pulling axis with the axis of the hinge pin. Attach the tension loading device to the adapter and apply the required load.

5.17 Hinge Impact Test

Prepare the test specimen in accordance with paragraph 5.4 and lock the door in the closed position. When testing hinges for out-swinging doors which have removable hinge pins and incorporate mechanical interlocks between the leaves of the hinges in the closed position and out-swinging door assemblies using such hinges, remove the hinge pins during this test. Set up the door ram pendulum weight so that its axis is hor-

horizontal, and perpendicular to the face of the door at a point 20 cm (8 in) from the bottom hinge, on a horizontal line through the mid-point of the hinge.

Attach an impact buffer, as described in paragraph 5.15, to the face of the door, centered on the impact point, and position the pendulum so that its striking nose just touches the surface of the buffer, when at rest. Pull back the pendulum weight to the height necessary to produce the required impact, and release it. Subject the door to two impacts at each required impact level, attaching a new buffer for each impact. After each impact, try to open the door.

A door component failure consists of any splitting or fracture of the door which allows it to be opened; a jamb/wall component failure consists of any splitting, fracture or pull-out of the attachment screws which allows the door to be opened; a hinge component failure consists of any damage to the leaves or pin of the hinge which allows the door to be opened.

Following the hinge impact test, inspect the components to determine whether there is sufficient damage to invalidate the subsequent test (paragraph 5.18); if there is, replace those damaged.

5.18 Bolt Impact Test

Prepare the test specimen in accordance with paragraph 5.4 and lock the door in the closed position. Set up the door ram pendulum weight so that its axis is horizontal, and perpendicular to the face of the door at a point defined by the intersection of a vertical line 20 cm (8 in) from the lock edge, and a line from the center of the bolt to the center of the mid-height hinge (or the mid-point between hinges, when the door is hung with two hinges).

Attach an impact buffer, as described in paragraph 5.15, to the face of the door, centered on the impact point, and position the pendulum so that it just touches the surface of the buffer when at rest. Pull back the pendulum weight to the height necessary to produce the required impact, and release it. Subject the door to two impacts at each required impact level, attaching a new buffer for each impact. After each impact, try to open the door by turning the knob, and test the dead bolt or dead latch for end pressure resistance as in paragraph 5.9.

A jamb/strike component failure consists of a pull-out or fracture of the strike attachment screws or any splitting, bending, or fracture of the door jamb at the strike which allows the door to be opened; a door component failure consists of any splitting or fracture of the door which allows it to be opened; a lock component failure consists of any damage to the lock mechanism or bolt which allows the door to be opened.

APPENDIX A—REFERENCES

1. American National Standard ANSI A115, July 1971 (ANSI A115.1 TO ANSI A115.11), "Specifications for Door and Frame Preparation for Hardware," American National Standards Institute, Inc., 1430 Broadway, New York, N.Y. 10018.

APPENDIX B—TEST EQUIPMENT

Test equipment suitable for use in evaluating the physical security of door assemblies and components is described below. While certain commercial instruments are identified to adequately describe the test equipment, in no case does such identification imply recommendation or endorsement, nor does it imply that the material or equipment described is necessarily the best for the purpose.

1. Door Ram

The door ram is a pendulum system with a cylindrical weight capable of delivering horizontal impacts of 200 joules (148 foot pounds-force). Figure B-1 is a photograph of such a system. A sketch of the ram is shown in figure B-2. It is a steel cylinder 15.2 cm (6 in) in diameter, 39.4 cm (15.5 in) long, with a hemispherical impact nose. It weighs 45 kg (99.2 lb). The impact nose used in this equipment is made from cast epoxy-polyamide resin; however, any durable impact resistant material is satisfactory. The suspension system for the door ram consists of four flexible steel cables providing a swing radius of 171 cm (5.61 ft), as shown in figure B-3. These cables are adjusted to equal length with turnbuckles such that the ram swings in a straight, true arc and are attached to a steel frame which can be adjusted to be level. Figure B-1 also includes a diagram of the pendulum system when elevated and at rest and the measurements required to calculate the impact energy of the system.

In use, it is convenient to clamp the pendulum system to the forks of a fork-lift truck, which allows rapid horizontal and vertical adjustment of the impact point of the ram. The use of a calibrated elevation stand, as shown in figure B-1, is a convenient means of quickly and reproducibly establishing the proper ram elevation for each required impact.

2. Component Ram

The component ram is a pendulum system capable of delivering impacts of 100 joules (74 foot pounds-force). A sketch of the pendulum system is shown in figure B-4. The pendulum weight has a diameter of 5.6 cm (2-3/16 in), a length of 83.8 cm (33 in), and weighs 16 kg (35.3 lb). The impact nose is made from a 1/4 inch carriage bolt with the square shank removed. The vacuum release mechanism, also shown in figure B-4, is a convenient means of holding the component ram in the elevated position and releasing it to deliver the required impact.

The height-of-drop of the pendulum for an impact of 100 joules (74 ft-lbf) is 63.7 cm (2.09 ft).

3. Vertical Impactor

The vertical impactor is a rigid pendulum system capable of delivering downward impacts of 100 joules (74 foot pounds-force). Figure B-5 shows a photograph of the system. The construction of the pendulum is shown in figure B-6, and the construction of the pivot assembly is shown in figure B-7.

The effective weight of the flat-nosed steel weight is 10 kg (22 lb). An impact of 100 J (74 ft-lbf) is provided by a drop height of 1.02 m (3.35 ft).

4. Torque Applicator

The torque applicator consists of a commercial torque wrench. In order to achieve adequate accuracy of the measured torque, it was necessary to bond strain gauges to the spring shaft of the torque wrench; these were connected to standard strain gauge read-out instrumentation. The system was calibrated to measure torque to 163 Nm (120 lbf-ft). This equipment is shown in figure B-8.

Two load adapters are used to apply the torque to door knobs and lock cylinders. Figure B-9 shows a sketch of the adapter used for door knobs. It is essentially a cylinder slightly larger than the diameter of the knob, with four set screws that are tightened against the side of the knob. The end of the cylinder away from the knob has a square shank that is gripped with a standard socket attached to the torque wrench.

The load adapter used to apply torque to lock cylinders is shown in figure B-10. It is essentially a steel disk having a spot face to accommodate the cylinder core, with a square shank on the opposite side, and three 1/8 inch holes drilled on a 3/8 inch radius from the center of the disk, spaced 120° apart.

5. Tension Loading Device

The tension loading device is a load and force measuring device with a capacity of 17,800 N (4000 lbf). A double-acting hydraulic ram connected directly to a load cell was used for this purpose. The ram was an ordinary auto-body jack with permanently connected hoses and pump. The ram had a capacity of 17,800 N (4000 lbf) in tension and 35,600 N (8000 lbf) in compression. The load was measured with a universal, strain gauge type load cell with a capacity of 22,000 N (5000 lbf) in tension and compression. Figure B-11 is a picture of this equipment together with a conventional strain-gauge read-out instrument. In use, the load is applied to the cylinder core or body using an adapter such as that shown in figure B-12.

6. Jamb Spreading Device

The jamb spreading device is a compressive-loading and force-measuring device with a capacity of 22,000 N (5000 lbf). This is the same equipment used as the tension loading device. The tensile loading rings are removed, and the force is applied to the jamb through two load distributing pressure plates made of 3 mm (1/8 in) steel, 40 x 120 mm (1.5 x 5 in) in size. The use of this equipment in the spreading of a door jamb is illustrated in figure B-13. The load is indicated on the "y" axis of an "x-y" plotter while the movement of the jamb/strike is indicated on the "x" axis. The movement of the jamb/strike was measured by means of a linear variable differential transformer attached to the door.

7. Compression Loading Device

The compression loading device has a load and force measuring capacity of 900 N (200 lbf). A universal testing machine was used for this equipment; however, the equipment described in paragraph 6 could be used for this purpose. The use of the double acting hydraulic ram would require the construction of a rigid frame to hold the ram in a vertical position above a fixed base. This base must be perpendicular to the axis of the ram, and there must be sufficient clearance between the base and the pressure face of the ram to allow the static bolt load fixture, with the lock installed in it, to be positioned directly under the ram pressure face.

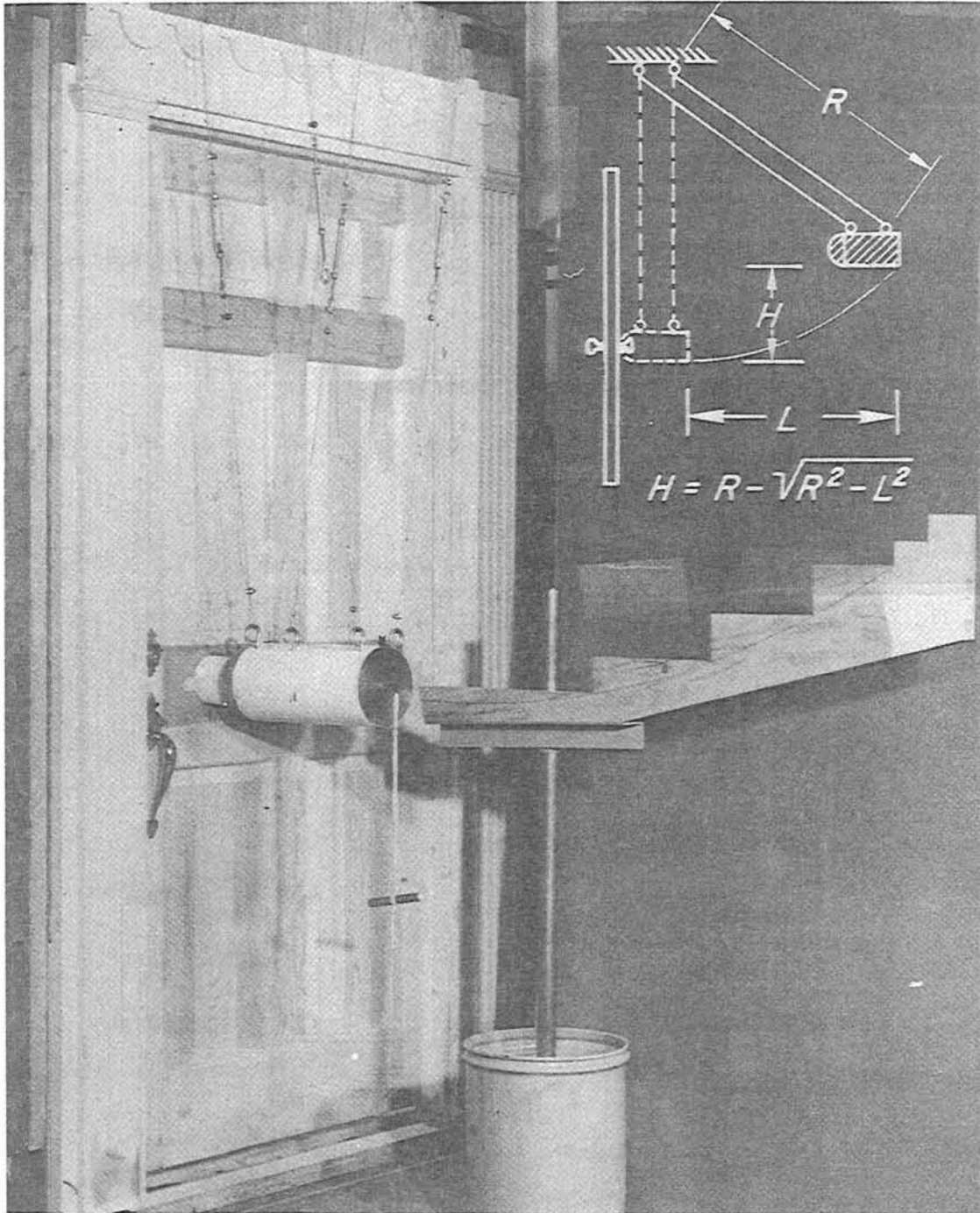

Figure B-1. Door Ram Pendulum System.

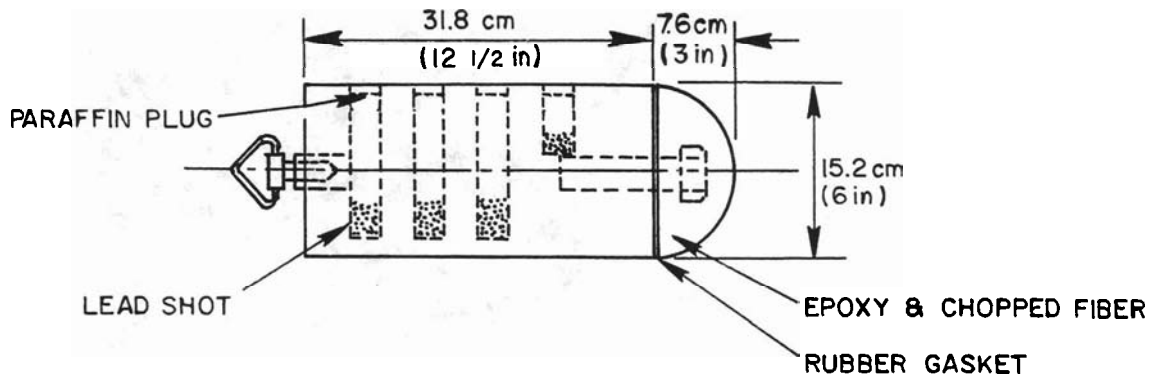

Figure B-2. Door Ram

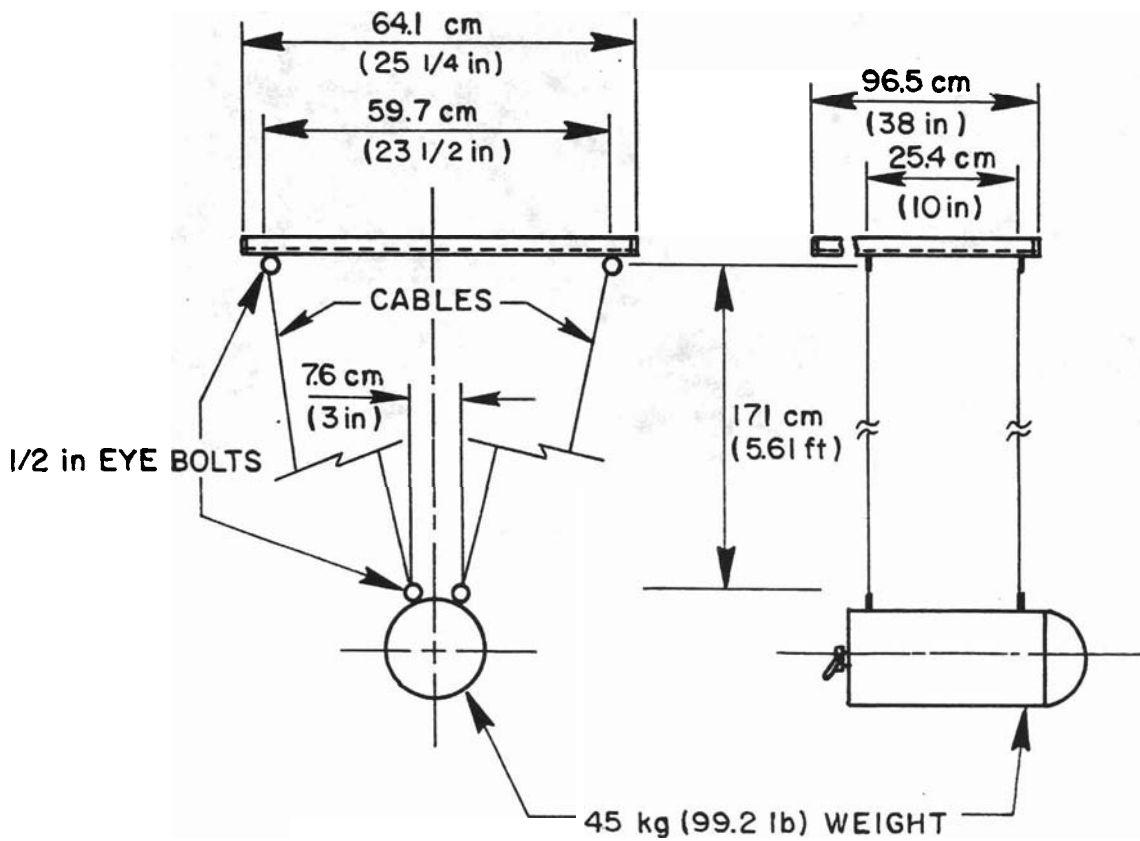

Figure B-3. Door Ram Suspension System

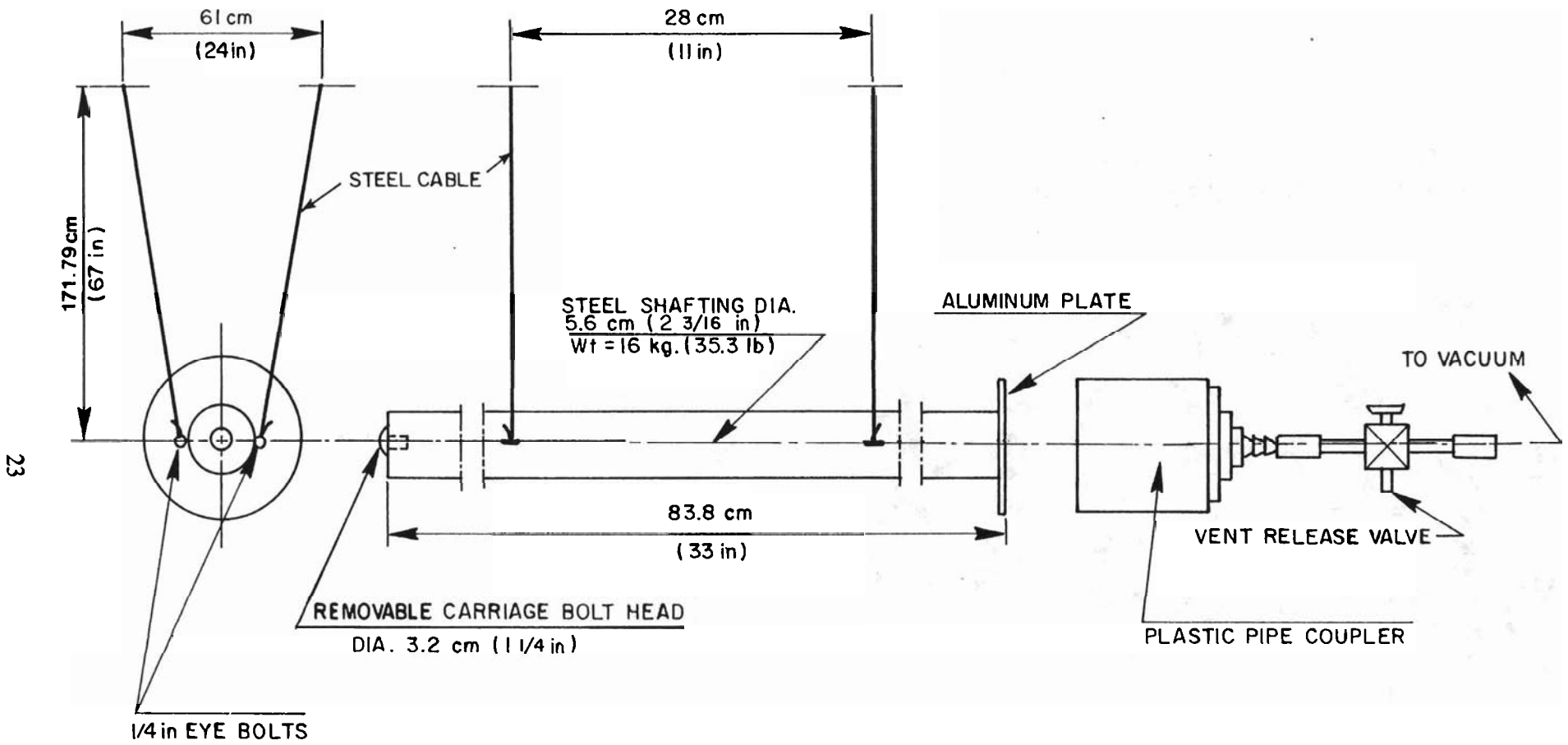

Figure B-4. Component Ram.

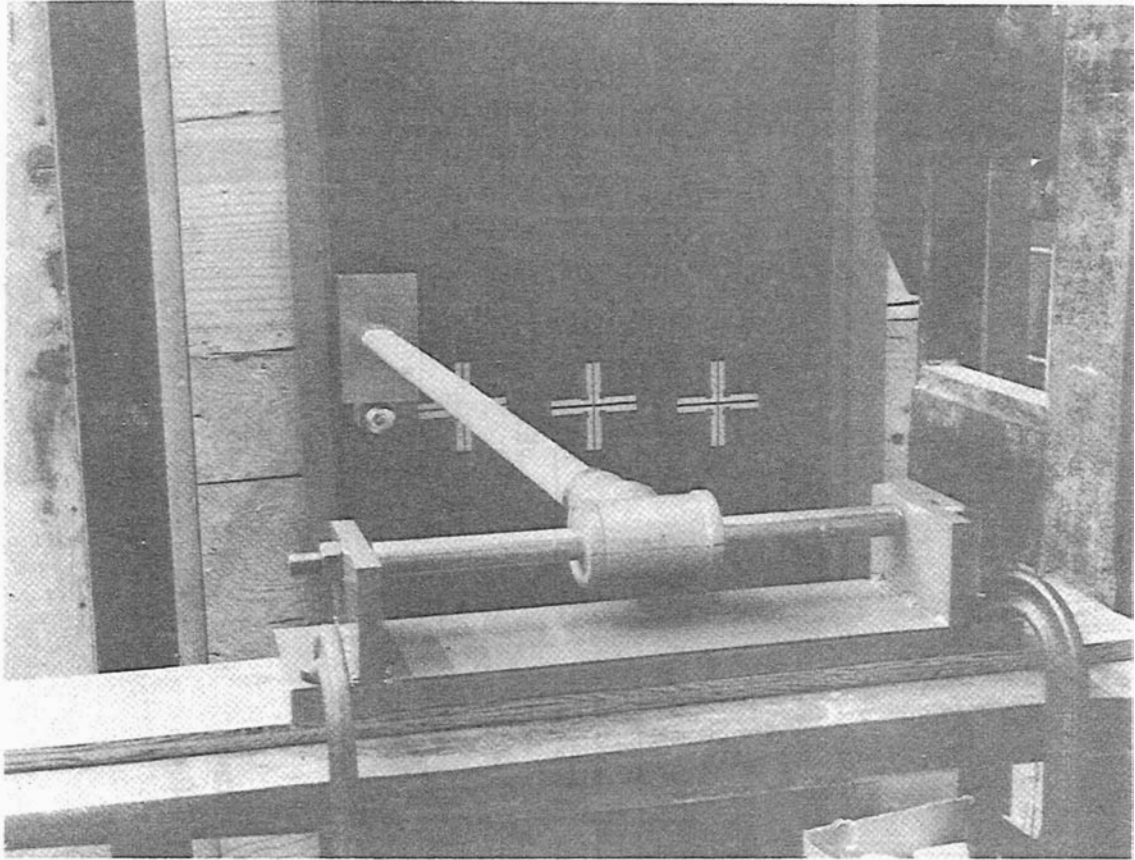

Figure B-5. Vertical Impactor.

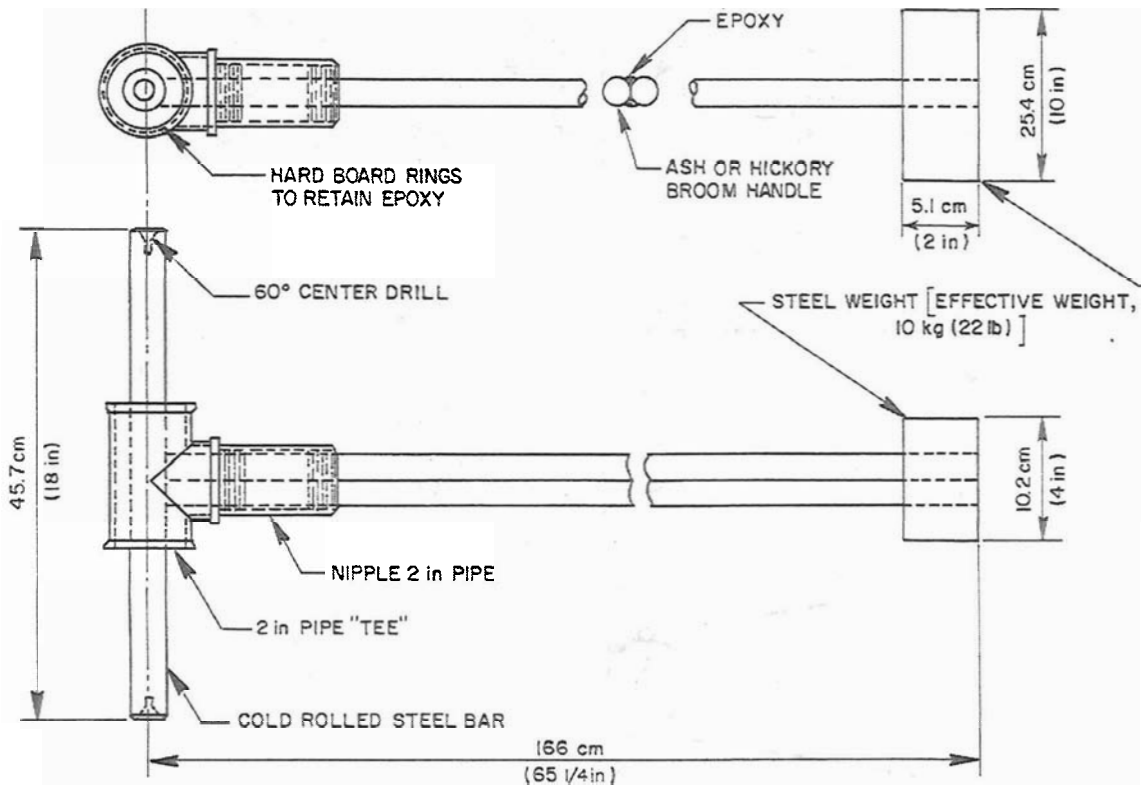

Figure B-6. Vertical Impactor

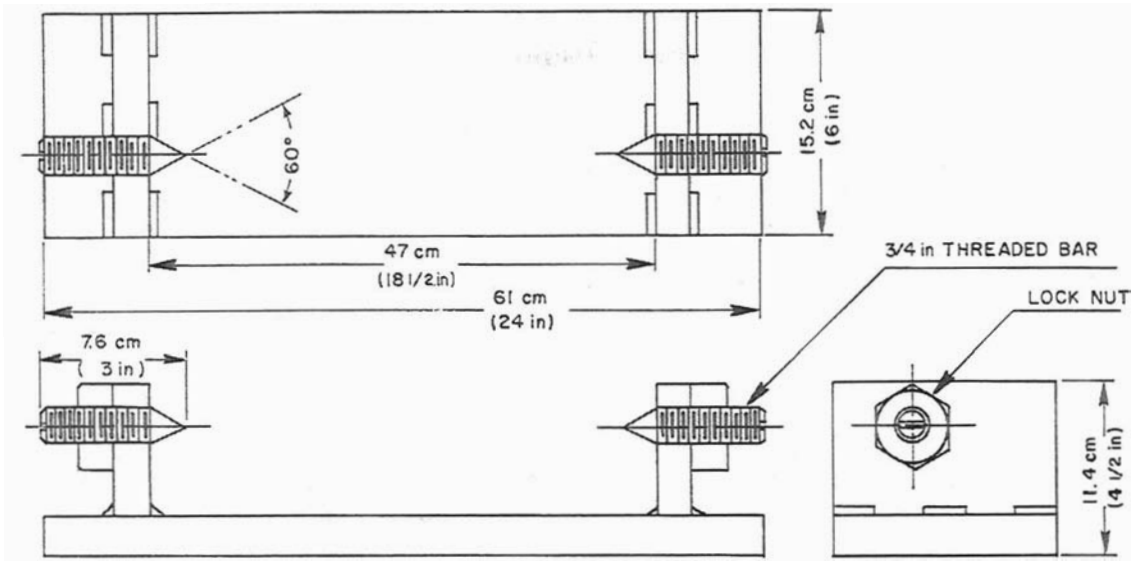

Figure B-7. Vertical Impactor Pivot Assembly

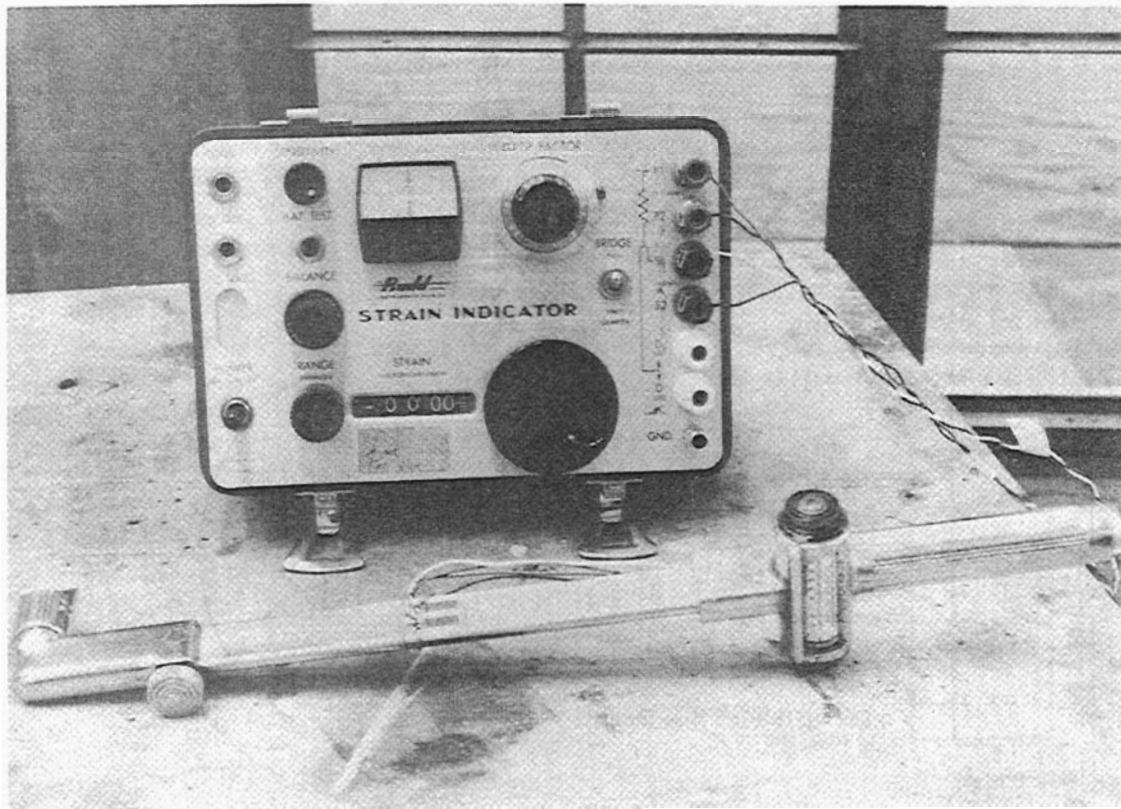

Figure B-8. Torque Applicator System.

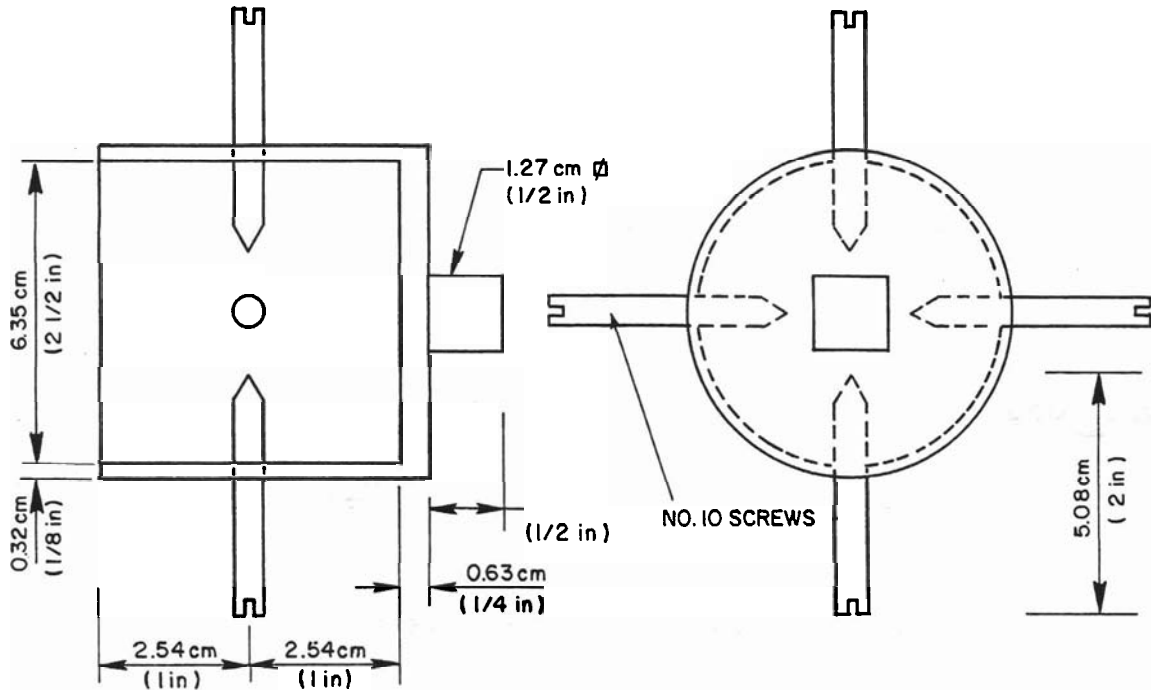

Figure B-9. Knob-Torque Adapter

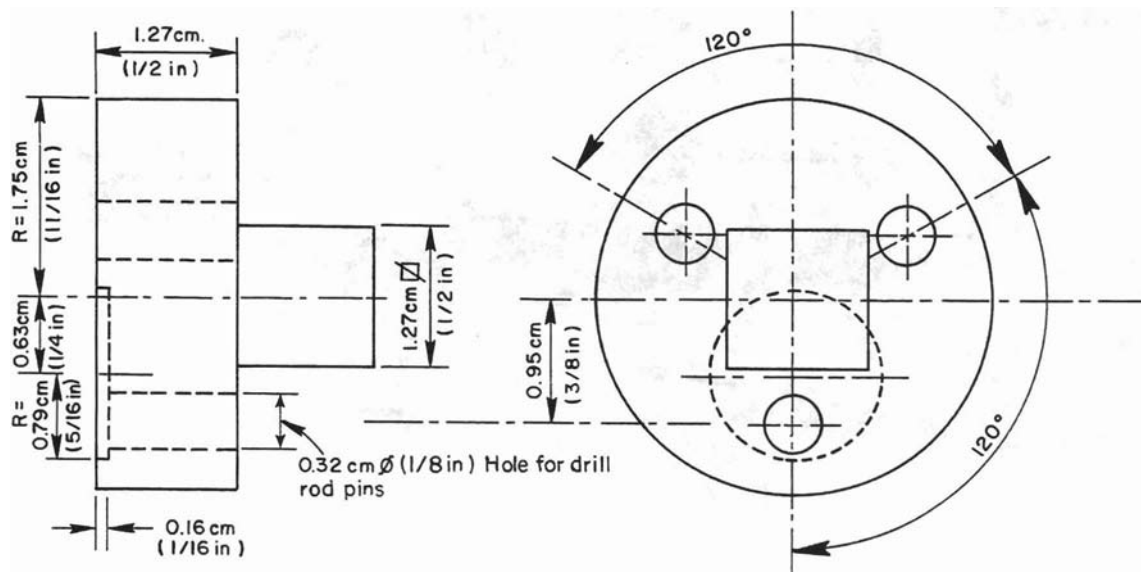

Figure B-10. Cylinder-Torque Adapter

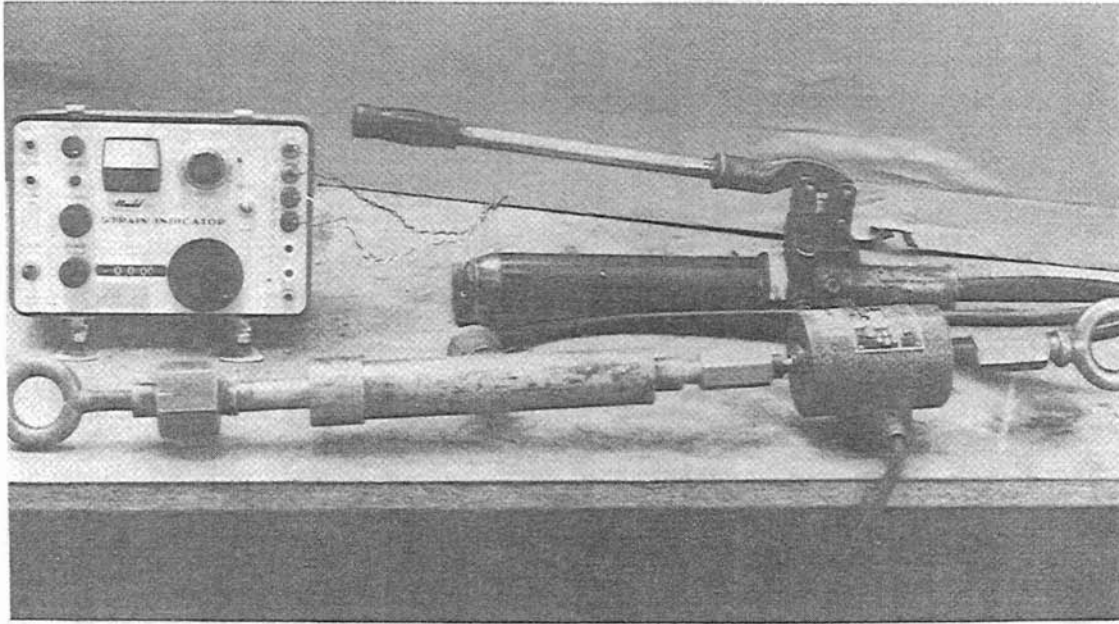

Figure B-11. Hydraulic Ram and Load Cell.

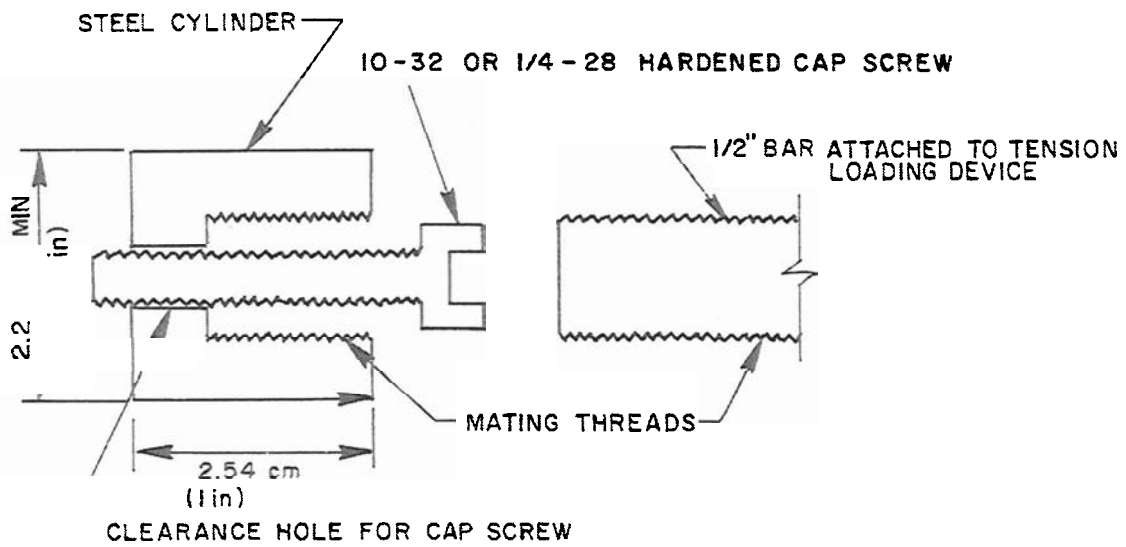

Figure B-12. Tension Loading Adapter

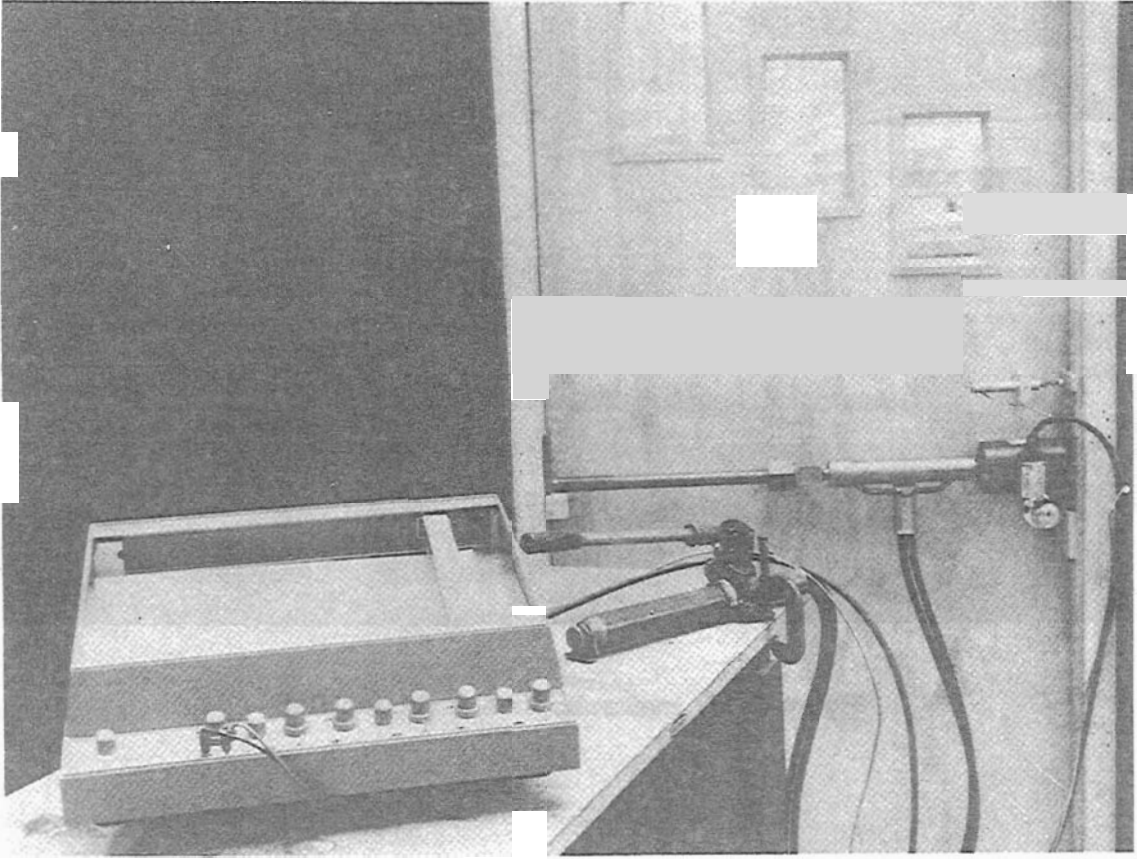

Figure B-13. Jamb Spreading Device.

PUBLICATIONS OF THE LAW ENFORCEMENT STANDARDS PROGRAM

The following publications of the Law Enforcement Standards Program issued by the National Institute of Law Enforcement and Criminal Justice are for sale by the U.S. Government Printing Office. For information concerning the availability and price of any of the publications write to: Superintendent of Documents, U.S. Government Printing Office, Washington, D.C. 20402.

NATIONAL INSTITUTE OF LAW ENFORCEMENT AND CRIMINAL JUSTICE STANDARDS (NILECJ-STD)

| NILECJ-STD | TITLE | GPO STOCK NO. |
|------------|---|-----------------|
| 0102.00 | Hearing Protectors for Use on Firing Ranges, March 1973 | 027-000-00182-3 |
| 0301.00 | Magnetic Switches for Burglar Alarm Systems, March 1974 | 027-000-00238-2 |
| 0302.00 | Mechanically Actuated Switches for Burglar Alarm Systems, May 1974 | 027-000-00258-7 |
| 0303.00 | Mercury Switches for Burglar Alarm Systems, May 1974 | 027-000-00254-4 |
| 0103.00 | Portable Ballistic Shields, May 1974 | 027-000-00253-6 |
| 0205.00 | Mobile Antennas, May 1974 | 027-000-00250-1 |
| 0601.00 | Walk-Through Metal Detectors for Use in Weapons Detection, June 1974 | 027-000-00256-1 |
| 0202.00 | Mobile FM Transmitters, October 1974 | 027-000-00287-1 |
| 0104.00 | Riot Helmets, October 1974 | 027-000-00286-2 |
| 0201.00 | Fixed and Base Station FM Transmitters, September 1974 | 027-000-00358-3 |
| 0602.00 | Hand-Held Metal Detectors for Use in Weapons Detection, October, 1974 | 027-000-00285-4 |
| 0203.00 | Personal/Portable FM Transmitters, October 1974 | 027-000-00293-5 |
| 0307.00 | Metallic Handcuffs, October 1974 | 027-000-00292-7 |
| 0304.00 | Passive, First Generation Night Vision Devices, June 1975 | 027-000-00325-7 |
| 0211.00 | Batteries for Personal/Portable Transceivers, June 1975 | 027-000-00342-7 |
| 0207.00 | Mobile FM Receivers, June 1975 | 027-000-00344-3 |
| 0603.00 | X-Ray Systems for Bomb Disarmanent, June 1975 | 027-000-00343-5 |
| 0305.00 | Active Night Vision Devices, June 1975 | 027-000-00346-0 |
| 0105.00 | Crash Helmets, June 1975 | 027-000-00347-8 |
| 0212.00 | RF Coaxial Cable Assemblies for Mobile Transceivers, September 1975 | 027-000-00357-5 |
| 0206.00 | Fixed and Base Station FM Receivers, September 1975 | 027-000-00358-3 |
| 0208.00 | Personal/Portable FM Receivers, October 1975 | 027-000-00366-4 |
| 0106.00 | Ballistic Helmets September 1975 | 027-000-00370-2 |

**LAW ENFORCEMENT STANDARDS
PROGRAM REPORTS (LESP-RPT)**

| LESP-RPT | TITLE | GPO STOCK NO. |
|-----------------|---|----------------------|
| 0201.00 | Batteries Used With Law Enforcement Communications Equipment — Comparison and Performance Characteristics, May 1972 | 027-000-00156-4 |
| 0202.00 | Batteries Used With Law Enforcement Communications Equipment — Chargers and Charging Techniques, June, 1973 | 027-000-00216-1 |
| 0203.00 | Technical Terms and Definitions Used With Law Enforcement Communications Equipment, June 1973 | 027-000-00214-5 |
| 0401.00 | Terms and Definitions for Police Patrol Cars, May 1974 | 027-000-00252-2 |
| 0304.00 | Simplified Procedures for Evaluating the Image Quality of Objective Lenses for Night Vision Devices, May 1974 | 027-000-00255-2 |
| 0303.00 | Image Quality Criterion for the Identification of Faces, May 1974 | 027-000-00261-7 |
| 0204.00 | Voice Privacy Equipment for Law Enforcement Communications Systems, May 1974 | 027-000-00260-9 |
| 0302.00 | Test Procedures for Night Vision Devices, May 1974 | 027-000-00257-9 |
| 0301.00 | Survey of Image Quality Criteria for Passive Night Vision Devices, June 1974 | 027-000-00259-5 |
| 0801.00 | Life Cycle Costing Techniques Applicable to Law Enforcement Facilities, May 1974 | 027-000-00284-6 |
| 0205.00 | Automatic Vehicle Location Techniques for Law Enforcement Use, September 1974 | 027-000-00282-0 |
| 0502.00 | Summary Report on Emergency Vehicle Sirens, September 1974 | 027-000-00289-7 |
| 0206.00 | Repeaters for Law Enforcement Communications Systems, October 1974 | 027-000-00288-9 |
| 0305.00 | Terms and Definitions for Intrusion Alarm Systems, October 1974 | 027-000-00290-1 |
| 0403.00 | The Police Patrol Car: State of the Art, July 1975 | 027-000-00345-1 |
| 0307.00 | Photographic Terms and Definitions, October 1975 | 027-000-00373-7 |
| 0101.01 | An Evaluation of Police Hand-gun Ammunition: Summary Report, October 1975 | 027-000-00374-5 |
| 0309.00 | Directory of Security Consultants, October 1975 | 027-000-00372-9 |
| 0207.00 | Electronic Eavesdropping Techniques and Equipment, September 1975 | 027-000-00362-1 |

**NATIONAL INSTITUTE OF LAW ENFORCEMENT AND CRIMINAL
JUSTICE GUIDES (NILECJ-GUIDE)**

| NILECJ-GUIDE | TITLE | GPO Stock No. |
|---------------------|---|----------------------|
| 0301.00 | Selection and Application Guide to Fixed Surveillance Cameras | 2700-000-00281-1 |