



National Institute of Justice
Technology Assessment Program

Control Units for Intrusion Alarm Systems

NIJ Standard-0321.00

ABOUT THE TECHNOLOGY ASSESSMENT PROGRAM

The Technology Assessment Program is sponsored by the Office of Development, Testing, and Dissemination of the National Institute of Justice (NIJ), U.S. Department of Justice. The program responds to the mandate of the Justice System Improvement Act of 1979, which created NIJ and directed it to encourage research and development to improve the criminal justice system and to disseminate the results to Federal, State, and local agencies.

The Technology Assessment Program is an applied research effort that determines the technological needs of justice system agencies, sets minimum performance standards for specific devices, tests commercially available equipment against those standards, and disseminates the standards and the test results to criminal justice agencies nationwide and internationally.

The program operates through:

The *Technology Assessment Program Advisory Council* (TAPAC) consisting of nationally recognized criminal justice practitioners from Federal, State, and local agencies, which assesses technological needs and sets priorities for research programs and items to be evaluated and tested.

The *Law Enforcement Standards Laboratory* (LESL) at the National Bureau of Standards, which develops voluntary national performance standards for compliance testing to ensure that individual items of equipment are suitable for use by criminal justice agencies. The standards are based upon laboratory testing and evaluation of representative samples of each item of equipment to determine the key attributes, develop test methods, and establish minimum performance requirements for each essential attribute. In addition to the highly technical standards, LESL also produces user guides that explain in nontechnical terms the capabilities of available equipment.

The *Technology Assessment Program Information Center* (TAPIC) operated by the International Association of Chiefs of Police (IACP), which supervises a national compliance testing program conducted by independent agencies. The standards developed by LESL serve as performance benchmarks against which commercial equipment is measured. The facilities, personnel, and testing capabilities of the independent laboratories are evaluated by LESL prior to testing each item of equipment, and LESL helps the Information Center staff review and analyze data. Test results are published in Consumer Product Reports designed to help justice system procurement officials make informed purchasing decisions.

All publications issued by the National Institute of Justice, including those of the Technology Assessment Program, are available from the National Criminal Justice Reference Service (NCJRS), which serves as a central information and reference source for the Nation's criminal justice community. For further information, or to register with NCJRS, write to the National Institute of Justice, National Criminal Justice Reference Service, Washington, DC 20531.

James K. Stewart, Director
National Institute of Justice

Technology Assessment Program

**NIJ Standard
for
Control Units for Intrusion
Alarm Systems**

NIJ Standard-0321.00

*A Voluntary National Standard Promulgated by the
National Institute of Justice*

June 1984

**U.S. Department of Justice
National Institute of Justice**

**U.S. DEPARTMENT OF JUSTICE
National Institute of Justice**

James K. Stewart, Director

ACKNOWLEDGMENTS

This standard was formulated by the Law Enforcement Standards Laboratory of the National Bureau of Standards under the direction of Lawrence K. Eliason, Chief of LESL and Daniel E. Frank, Manager, Security Systems Program. Suggestions and editorial contributions were made by Jacob J. Diamond, former Chief of LESL. Technical research was performed by Martin L. Kite and Maris Juberts under the supervision of Gerard N. Stenbakken. The preparation of this standard was sponsored by the National Institute of Justice, Lester D. Shubin, Standards Program Manager. The standard has been reviewed and approved by the Technology Assessment Program Advisory Council (TAPAC) and adopted by the International Association of Chiefs of Police (IACP) as an IACP standard.

FOREWORD

This document, NIJ Standard-0321.00, Control Units for Intrusion Alarm Systems, is an equipment standard developed by the Law Enforcement Standards Laboratory of the National Bureau of Standards. It is produced as part of the Technology Assessment Program of the National Institute of Justice. A brief description of the program appears on the inside front cover.

This standard is a technical document that specifies performance and other requirements equipment should meet to satisfy the needs of criminal justice agencies for high quality service. Purchasers can use the test methods described in this standard themselves to determine whether a particular piece of equipment meets the essential requirements, or they may have the tests conducted on their behalf by a qualified testing laboratory. Procurement officials may also refer to this standard in their purchasing documents and require that equipment offered for purchase meet the requirements. Compliance with the requirements of the standard may be attested to by an independent laboratory or guaranteed by the vendor.

Because this NIJ standard is designed as a procurement aid, it is necessarily highly technical. For those who seek general guidance concerning the selection and application of law enforcement equipment, user guides have also been published. The guides explain in nontechnical language how to select equipment capable of the performance required by an agency.

NIJ standards are subjected to continuing review. Technical comments and recommended revisions are welcome. Please send suggestions to the Program Manager for Standards, National Institute of Justice, U.S. Department of Justice, Washington, DC 20531.

Before citing this or any other NIJ standard in a contract document, users should verify that the most recent edition of the standard is used. Write to: Chief, Law Enforcement Standards Laboratory, National Bureau of Standards, Washington, DC 20234.

Lester D. Shubin
Program Manager for Standards
National Institute of Justice

NIJ STANDARD FOR CONTROL UNITS FOR INTRUSION ALARM SYSTEMS

CONTENTS

	Page
Foreword.....	iii
1. Purpose and Scope.....	1
2. Classification.....	1
3. Definitions.....	1
4. Requirements.....	3
4.1 Acceptance Criteria.....	3
4.2 User Information.....	3
4.3 Material and Configuration.....	3
4.4 Modes of Operation.....	3
4.5 Protective Loops(s).....	4
4.6 Transmission Signals.....	5
4.7 Stability Requirement.....	5
4.8 Electromagnetic Susceptibility Requirement.....	5
4.9 Tamper Switch.....	5
4.10 Standby Power (Type II Units).....	6
4.11 Local Alarm Annunciator Device Control.....	6
5. Test Methods.....	6
5.1 Sampling.....	6
5.2 Test Conditions.....	6
5.3 Test Equipment.....	6
5.4 Material and Configuration Test.....	7
5.5 Mode Tests.....	7
5.6 Protective Loop Tests.....	8
5.7 Transmission Signal Tests.....	8
5.8 Stability Tests.....	11
5.9 Electromagnetic Susceptibility Tests.....	11
5.10 Tamper Switch Test.....	13
5.11 Standby Power Operation Test.....	14
5.12 Local Alarm Annunciator Device Control Test.....	14
Appendix A—References.....	15

NIJ STANDARD FOR CONTROL UNITS FOR INTRUSION ALARM SYSTEMS

1. PURPOSE AND SCOPE

This standard establishes performance requirements and test methods for intrusion alarm control units used in protecting residential or commercial premises. Upon actuation of an intrusion sensing device or the detection of a trouble condition, the control unit may initiate a local audible alarm, transmit an alarm signal to a police department, or transmit an alarm signal to a central station. The performance characteristics addressed are those that affect the reliability of the device with emphasis on those that affect false alarm susceptibility and tamper resistance.

2. CLASSIFICATION

For the purposes of this standard, control units are classified Type I or Type II based on whether or not standby power is included within the unit.

2.1 Type I

These units do not include standby power.

2.2 Type II

These units continue to operate from internal standby power when the normal ac power fails.

3. DEFINITIONS

3.1 Alarm State

The condition of a sensor of an intrusion alarm system that causes a control unit in the secure state to transmit an alarm signal.

3.2 Annunciator Panel

An alarm monitoring device that consists of a number of visible signals such as "flags" or lamps indicating the status of the detectors in an alarm system or systems. Each circuit in the device is usually labeled to identify the location and condition being monitored. In addition to the visible signal, an audible signal is usually associated with the device. When an alarm condition is reported, a signal is indicated visibly, audibly, or both. The visible signal is generally maintained until reset either manually or automatically.

3.3 Audible Warning Device

A sound producing module mounted within the control unit that is used to signal the operator that a protection loop is not secure.

3.4 Electromagnetic Interference (EMI)

The impairment of the reception of a wanted electromagnetic signal or the creation of a spurious electromagnetic signal by an electromagnetic disturbance. This can be caused by radiated electromagnetic interference sources, such as lightning or radio transmitters, or conducted electromagnetic interference transmitted through power lines from other electrical devices.

3.5 End-of-Line Resistance

A technique of monitoring the alarm transmission line and the status of an intrusion alarm control unit connected to an annunciator panel. The alarm signal transmission line is terminated at the alarm control unit with one resistance to indicate a secure state and a different resistance to indicate an alarm state. Other resistances, including an open or short circuit, indicate line trouble or tampering.

3.6 Interrogation and Reply Transmission System

An alarm transmission scheme used to achieve inherent line supervision. A transmitter at one end of the signal transmission line sends out a coded interrogation signal to a device or control unit; the device or control unit must reply with a properly coded transmission signal within a specified period of time.

3.7 Line Supervision (Line Security)

Electronic protection of an alarm transmission line accomplished by sending a continuous or coded signal through the circuit. A change in the circuit characteristics, such as a change in impedance due to the circuit's having been tampered with, will be detected by the monitoring circuit. The monitoring circuit initiates an alarm if the change exceeds a predetermined amount.

3.8 Local Alarm Annunciating Device

A noisemaking device such as a siren, bell, or horn located in the area of the alarmed premises and used as part of an alarm system to indicate an alarm state.

3.9 Mode (Of Operation)

A clearly defined set of operating conditions. In this standard, the term "mode" is used to describe the operation of an alarm system (see sec. 3.15, State) as opposed to a stable condition while waiting for something to happen.

3.10 Polarity Reversal Transmission

A commonly used technique of transmitting alarm system control unit status information from a subscriber to the monitoring station using a dc signal over a two-conductor alarm signal transmission line. In the secure state, one line is positive with respect to the other. In the alarm state, the lines change polarity with respect to each other. Line trouble is indicated when line current drops below a certain level.

3.11 Protection Loop

A circuit consisting of one or more sensors physically placed so as to define a protected area and electrically connected to a control unit. A given control unit may be capable of monitoring more than one protected area.

3.12 Pulse Transmission

A technique for transmitting alarm unit status information over a two-conductor alarm signal transmission line (e.g., leased telephone lines) using low-frequency pulses (1–20 Hz). An alarm signal is indicated by a change in the pulse rate. Line trouble is indicated by the absence of any pulses.

3.13 Reset

To restore a device to its original (normal) condition after an alarm or trouble signal.

3.14 Secure State

The condition of an alarm system in which all sensors and control units are ready to respond to an intrusion.

3.15 State

In this standard the term “state” refers to a stable condition in which the control unit provides an appropriate signal and that signal will continue until an outside intervention. For example, when in the secure state the control unit should not signal an alarm unless a sensor signals that an intrusion has occurred. If an intrusion does occur the control unit should enter the alarm state and signal an alarm until the entire system (control unit and sensors) is reset.

3.16 Tamper Switch

A switch that initiates an alarm signal if an attempt is made to gain access to the interior of a protected piece of equipment. This switch is usually activated by an attempt to remove the cover of the equipment.

4. REQUIREMENTS

4.1 Acceptance Criteria

The intrusion alarm system control unit model meets the requirements of this standard if all three sample units (sec. 5.1) pass all the required tests. The tests shall be performed in the general order in which they appear in this standard.

4.2 User Information

The following information shall be supplied to the user by the manufacturer or distributor:

- (a) Nominal operating voltages.
- (b) Type of transmission signals the control unit uses.
- (c) Classification (sec. 2).
- (d) Complete installation, wiring, and adjustment procedures, including any installation restrictions.
- (e) Operating instructions.
- (f) Standby power requirements, including battery identification, and minimum period of standby operation guaranteed using the specified battery (Type II devices).
- (g) For rechargeable batteries, the minimum time to fully recharge the batteries if equipment includes an integral battery charging unit.
- (h) The operation of transmission line features and equipment tamper protection features.
- (i) Certification of compliance with this standard.

4.3 Material and Configuration

The materials, parts, and components of the control unit shall comply with the requirements of Underwriters’ Laboratories Standard UL 365, “Police Station Connected Burglar Alarm Units and Systems” [1]¹, sections 4 through 12.

4.4 Modes of Operation

When tested in accordance with sections 5.5.1 through 5.5.4, the control unit shall respond to each test condition as described in the sections below.

¹ Numbers in brackets indicate references in appendix A.

4.4.1 Protection Loop Test Mode

The control unit shall provide for a protection loop test mode. It shall be necessary to switch to the protection loop test mode before activating another mode except the reset mode and the unit-off mode. While in this state, units with a single protection loop shall give a visual display of the status of that loop and units with multiple protection loops shall give a visual display of the status of each loop. The unit shall not transmit an alarm signal while in the protection loop test state. If any of the protection loops are not secure, it shall not be possible to switch the control unit to any operational mode and an audible warning device shall be activated at the control unit in addition to the visual indication. This mode may be combined with the reset mode.

4.4.2 Protection-On Mode

The control unit shall provide for a protection-on mode. The control unit can be switched to this mode only if the protection loop(s) is(are) secure. The unit shall transmit a secure signal when it achieves the protection-on state. For loops not used for holdup signaling, whenever the protection loop signals an alarm, the control unit shall transmit an alarm signal and activate the local alarm annunciator device(s) if used. The unit shall continue to transmit the alarm signal until it has been switched to the reset mode. If used, the local annunciating device(s) shall be activated for a period of time between 5 and 30 min after which it (they) shall be deactivated until the control unit has been switched to the reset mode. For loops used for holdup signaling, whenever these loops signal a holdup, the control unit shall transmit an alarm signal or, optionally, a special holdup signal and shall not activate any local alarm annunciating device(s). As with the other loops, the control unit shall continue to transmit the alarm signal until it has been switched to the reset mode. Multiloop units may have several modes where various combinations of the loops are being monitored.

4.4.3 Reset Mode

The control unit shall provide for a reset mode, which shall stop any alarm signal transmission and immediately deactivate the local alarm annunciating device and the control unit audible warning signal.

4.4.4 Exit Delay Mode

An exit delay mode is not required; however, if it is provided it shall operate as specified here. It shall not be possible to activate an exit delay mode without first performing a protection loop test. When in the exit delay state, the unit shall not respond to any signals from the protection loops (holdup loop excepted) for a period of time. This time shall be adjustable to, or fixed at, a time between 15 and 45 s. After this delay has expired, the unit shall enter the protection-on state. If the unit has a holdup loop, the exit delay mode shall not modify the normal action of this loop as specified in section 4.4.2.

4.4.5 Entrance Delay Mode

An entrance delay mode is not required; however, if it is provided it shall operate as specified here. When in the protection-on state, the unit shall delay transmission of an alarm signal in response to a protection loop (holdup loop excepted) signal for a period of time. This time shall be adjustable to, or fixed at, a time between 15 and 45 s. After this delay, if the control unit has not been switched to another mode, it shall signal an alarm the same as it would for a control unit without an entrance delay mode. During the delay period, the unit shall produce an audible warning sound at the control unit. If the unit has a holdup loop, the operation of that loop shall cause an immediate alarm transmission. The audible warning sound shall not be produced in response to the activation of the holdup loop.

4.5 Protective Loop(s)

When tested in accordance with section 5.6 each protective loop shall have an open circuit voltage equal to or less than 30 V and a short circuit current equal to or less than 125 mA. The circuits shall recognize as a low impedance state a resistance of 2 k Ω or less held on for at least 200 ms and shall recognize as the high impedance state a resistance of 20 k Ω or more held on for at least 200 ms. The circuits shall not respond to a change of impedance state that lasts for less than 200 ms and shall respond before 750 ms have elapsed from the time the impedance changes.

4.6 Transmission Signals

The control unit shall be capable of transmitting a polarity reversal type signal even though the usual means of transmission is by some other technique. The polarity reversal requirement may be satisfied by having an adaptor circuit available. The control unit shall be tested and meet the requirements for this and any other signaling methods that are provided.

4.6.1 Polarity Reversal Technique

When tested in accordance with section 5.7.1, the control unit shall provide a current of at least 5 mA with a series line resistance of 5 k Ω for polarity reversal signal transmission.

4.6.2 End-of-Line Resistance Technique

When tested in accordance with section 5.7.2, control units that use the end-of-line resistance method of signal transmission shall provide proper operation when used with a series line resistance of 5 k Ω . The signal current for the alarm state shall be at least two times the signal for the secure state.

4.6.3 Low-Frequency Pulsar Technique

When tested in accordance with section 5.7.3, control units that use the low-frequency pulse method of signal transmission shall provide proper operation when used with a series line resistance of 5 k Ω . The pulse current shall be at least 5-mA peak pulse current.

4.6.4 Alternating-Current Line-Carrier Technique

When tested in accordance with section 5.7.4, control units that use the alternating-current line-carrier method of signal transmission shall provide at least 750-mV rms when used with any series line resistance from 0 to 5 k Ω inclusive and with a simulated 600- Ω impedance transmission line.

4.6.5 Interrogation and Reply Technique

When tested in accordance with section 5.7.5, control units that use the interrogation and reply method of signal transmission shall provide at the transmitter at least 750-mV rms when used with any series line resistance from 0 to 5 Ω inclusive and with a simulated 600- Ω impedance transmission line. The control unit shall operate properly when the signal it receives from the annunciator panel has a voltage amplitude of one-tenth (-20 dB) of the transmitted signal level.

4.6.6 Combination of Two or More Transmission Techniques

When tested in accordance with section 5.7.6, each portion that uses two or more types of transmission signals for increased line security shall function properly and satisfy the requirements of the individual transmission technique specified in sections 4.6.1 through 4.6.5.

4.7 Stability Requirement

When tested in accordance with section 5.8.1 through 5.8.6, the control unit shall meet the requirements of sections 4.5 and 4.6. There shall be no alarms other than those expected while conducting these tests.

4.8 Electromagnetic Susceptibility Requirement

When subjected to radiated electromagnetic fields, conducted interference, and simulated lightning voltage surges on the telephone lines in accordance with sections 5.9.1 through 5.9.3, the control unit shall not signal any false alarms.

4.9 Tamper Switch

Each control unit shall incorporate tamper protection in the form of a tamper switch. When tested in accordance with section 5.10, the tamper switch shall not cause the system to signal an alarm until the cover or cover screw, whichever actuates the tamper switch, has moved at least 1.5 mm (0.06 in) and shall cause the unit to signal an alarm before the cover has moved a sufficient distance to permit a direct line-of-sight to electrical circuits or adjustment controls.

4.10 Standby Power (Type II Units)

When tested in accordance with section 5.11, the control unit shall not signal an alarm when power is interrupted and restored, and following operation from the standby power for the period of time specified by the manufacturer, section 4.2(g), the unit shall still meet the requirements of sections 4.5 and 4.6. If the unit incorporates an integral battery charging circuit, the control unit shall meet the requirements of this standard when power is restored, and the charging circuit shall fully recharge the batteries in the period of time specified by the manufacturer, section 4.2(g).

4.11 Local Alarm Annunciator Device Control

This is an optional output control circuit. If provided, it shall consist of a contact closure rated not less than 2 A at nominal 110 V ac or a voltage that when tested in accordance with section 5.12 will deliver at least 12 V dc to a 6- Ω load. If an integral electronic siren is provided, then the manufacturer's specification shall govern the output.

5. TEST METHODS

5.1 Sampling

Three control units shall be selected at random for testing. Each unit shall include the power supply, controls, protective loop circuitry, and transmission circuitry. The transmission circuitry shall provide, at least, for reverse polarity signaling and, optionally, other methods. An annunciator shall be selected that meets the requirements of NJ Standard-0320.00 to display the status of the reverse polarity signal and any optional signals provided [2].

5.2 Test Conditions

Unless otherwise specified, all tests shall be performed with the control unit operated at its specified nominal operating voltage and in a typical laboratory ambient environment. In all cases, the control unit shall be allowed to warm up for a minimum of 5 min after being turned on, or as specified by the manufacturer, before any tests are performed.

5.3 Test Equipment

5.3.1 Decade Resistors

The decade resistors shall have a variable resistance range from 0 to 9 k Ω with steps of 10 Ω . The values of the decade resistor shall have an uncertainty of less than 1 percent.

5.3.2 DC Milliammeter

The dc milliammeter shall have the capability of measuring current levels as high as 130 mA with an uncertainty of less than 3 percent.

5.3.3 Differential Input Oscilloscope

The oscilloscope shall have a high impedance differential input amplifier or plug-in amplifier with a bandwidth from dc to at least 1 MHz. Input resistance shall be 1 M Ω or higher while input capacitance shall be 50 pF or less. The common-mode rejection ratio shall be at least 500:1 for ac or dc signals. The oscilloscope shall have the capability of measuring test signals over a range of 1 mV to 100 V with an uncertainty of less than 5 percent.

5.3.4 Voltmeter

The voltmeter shall have a differential input with an input resistance of 1 M Ω or higher. It shall be capable of measuring dc test signals over a range of 10 mV to 100 V with an uncertainty of less than 2 percent, and 10 Hz to 10 kHz ac signals over a range of 1 mV to 130 V with an uncertainty of less than 3 percent of the reading.

5.3.5 Environmental Test Chamber

The environmental test chamber(s) shall be of a size sufficient to accommodate the control units and be capable of maintaining any temperature in the range 0 to 50 °C (32 to 122 °F) within ± 2 °C (± 3.6 °F). A recorder shall continuously record the temperature during the tests with an accuracy of ± 1 °C (± 1.8 °F).

The humidity test chamber(s) shall be capable of maintaining any humidity in the range from 20 percent to at least 90 percent relative humidity within ± 2 percentage points over the entire range of relative humidity at 30 ± 5 °C (86 ± 9 °F). A recorder shall continuously record the relative humidity and temperature during the test with an uncertainty of less than 1 percent.

5.3.6 Pulse Generator

The pulse generator shall have pulse width control capable of adjusting pulse width over the range of 10 ms to 5 s. Output impedance shall be 50 Ω or less and pulse amplitude adjustable up to 15 V. The pulse initiation shall be manually controllable. The pulse generator shall provide an adjustable bias output of up to ± 10 -V dc and both positive and negative pulses.

5.3.7 Time Interval Measuring Instrumentation

The time interval measuring instrumentation shall consist of an electronic timer, chart recorder, storage oscilloscope, or similar equipment capable of measuring time delay intervals with an uncertainty of less than 0.2 ms.

5.3.8 Adjustable Regulated Power Supply

The regulated power supply shall be capable of providing 50-V dc maximum output with 0.1 percent regulation, 10 mV or less ripple, and a current of at least 50 mA.

5.3.9 High-Voltage Power Supply

The high-voltage power supply for the lightning surge test shall be capable of charging the 3.3- μ F capacitor to 600-V dc in 10 s or less.

5.4 Material and Configuration Test

The materials and components of each control unit shall be examined to determine conformance with sections 4 through 12 of Underwriters' Laboratories' Standard UL 365 [1].

5.5 Mode Tests

Connect at least one sensor to each of the protection loops and monitor the signals from each of the transmitting and output control circuits (including the local alarm annunciator device control circuit if present) for each test below.

5.5.1 Loop Test Mode

Place all of the sensors in their secure state. Switch the control unit to the loop test mode. Record the visual indicator status as one of the sensors in each protection loop is operated. In addition, record the outputs of the transmitting and other output circuits including that of the local annunciator device control if provided.

5.5.2 Protection-On and Reset Modes

For each (if there is more than one) protection-on mode, set all of the sensors in the protection loop(s) to the secure state. Switch the control unit to the reset mode, then to the protection mode being tested. Change the state of a sensor in one loop, then return it to the initial state. Note the status of the signals from the transmitting and other output circuits before the sensor is changed, while it is changed, and after it has been restored. Return the control unit to the reset position and back to the protection-on position; note the status of the signals from the output circuits during each step. Continue in this manner until each protection loop and each sensor has been tested for each protection-on mode.

5.5.3 Exit Delay Mode

If the exit delay is adjustable, adjust the exit delay in accordance with the manufacturer's instructions to approximately 30 s. Switch the control unit to the exit delay mode and immediately (within 3 s) actuate a sensor in one of the protection loops affected by this delay. Time the delay from switching to the exit delay mode until an alarm is signaled by the unit. Measure the time delay with a stopwatch or other device to an uncertainty of less than 2 s. If the unit has a protection loop designated as a holdup loop, repeat the test using a sensor in this loop.

5.5.4 Entrance Delay Mode

If the entrance delay is adjustable, adjust the entrance delay in accordance with the manufacturer's instructions to approximately 30 s. Switch the control unit to the entrance delay mode. (If this mode is combined with the exit delay mode, then wait at least twice the time measured in accordance with section 5.5.3 for the exit delay time before proceeding.) Actuate a sensor in one of the protection loops affected by this delay. Time the delay from actuating the protection loop sensor until an alarm is signaled by the unit. Measure the time delay with a stopwatch or other device to an uncertainty of less than 2 s. If the unit has a protection loop designated as a holdup loop, repeat the test using a sensor in this loop.

5.6 Protective Loop Tests

Connect the control unit as shown in figure 1. Adjust the decade resistor, R, to 0 Ω . Using the pulse generator to turn the solid state switch (2N6660 or equivalent) on, then off; measure the steady state closed circuit current and the steady state open circuit voltage. Note: The solid state switch must provide an on-state and an off-state time interval, each of which being longer in duration than the combined response time of the meters and the time required to read the meters to insure that steady state values are read.

Readjust the resistor, R, to 2 k Ω . Set the polarity of the pulse generator so that a pulse will close the circuit if the loop is normally open or will open the circuit if the loop is normally closed. Set the pulse duration to 200 ms. With the control unit reset, manually trigger the pulse generator and note if the control unit signals a continuous alarm. Repeat this for a total of five test actuations. Reset the pulse duration to 190 ms and repeat the above test.

Reset the control unit and set the pulse generator for 1 s. Manually trigger the pulse generator and measure the time interval between the actuation of the pulse generator and the signaling of the alarm by the control unit.

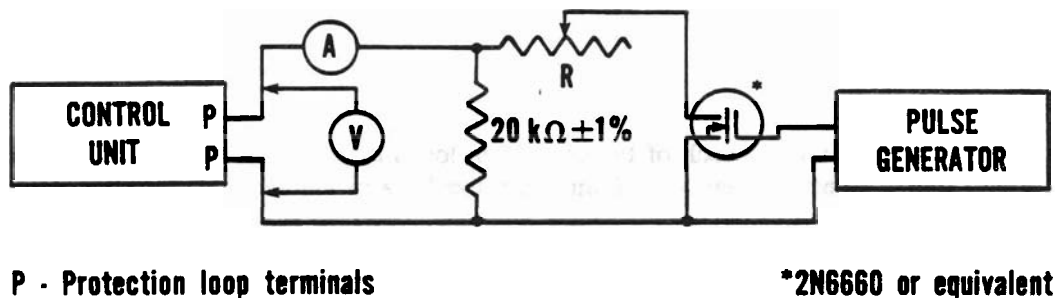

FIGURE 1. Setup for testing the protection loops.

5.7 Transmission Signal Tests

Test the control unit for polarity reversal signal transmission and any additional signal transmission methods provided.

5.7.1 Polarity Reversal Technique

Connect the control unit to the annunciator as shown in figure 2. Set the decade resistor, R, to 0 Ω , adjust the control unit in accordance with the manufacturer's instructions to provide 5 mA of line current, and measure the current in the signal loop for both a secure signal and an alarm signal. Repeat this procedure with R set at 5 k Ω , including the adjustment of the line current.

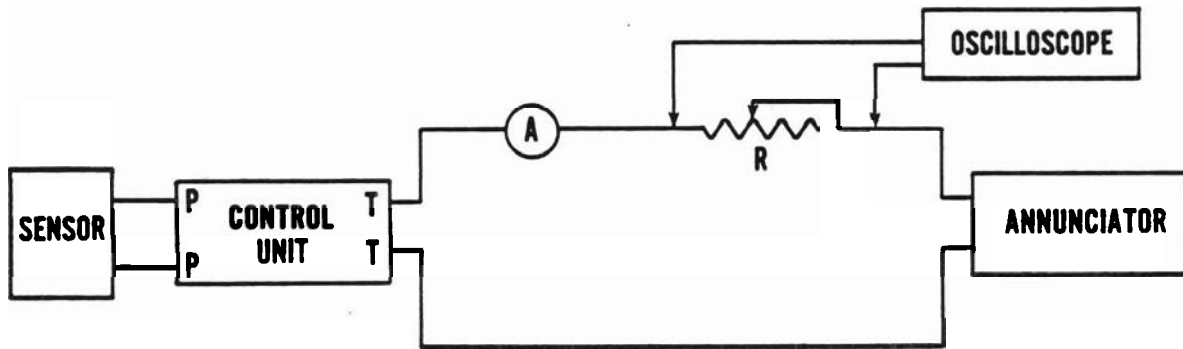

T - Transmission loop terminals
P - Protection loop terminals

FIGURE 2. Setup for transmission signal testing (reverse polarity and low-frequency pulse test).

5.7.2 End-of-Line Resistance Technique

Connect the control unit to the annunciator as shown in figure 3. Select R_{L1} and R_{L2} as specified by the manufacturer for use with a line resistance of $5\text{ k}\Omega$. If possible choose $R_{L2} > (1.5 R_{L1} + 7.5\text{ k}\Omega)$. This will provide at least a 2.5 to 1 ratio between the secure state signal and the alarm state signal with a $5\text{-k}\Omega$ line resistance. Set the decade resistor to $0\ \Omega$, adjust the control unit in accordance with the manufacturer's instructions to provide 10 mA of signal loop current when the control unit is in the secure state, and measure the signal loop current while the control unit is in the alarm state. Repeat this procedure with the decade resistor set at $5\text{ k}\Omega$.

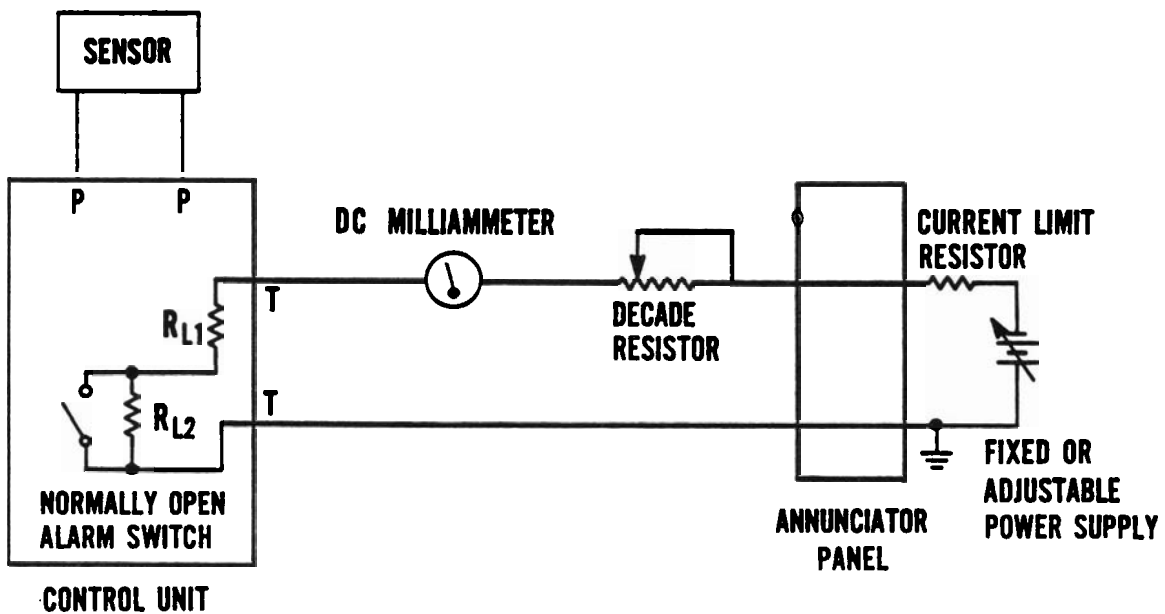

P - Protection loop terminals
T - Transmission loop terminals

FIGURE 3. Setup for end-of-line signal transmission testing.

5.7.3 Low-Frequency Pulsar Technique

Connect the control unit to the annunciator panel as shown in figure 2. Set the decade resistor, R , to $5\text{ k}\Omega$, adjust the control unit as specified by the manufacturer, and use the oscilloscope to measure the peak pulse voltage in the signal loop for both a secure signal and an alarm signal. Using the measured value of peak pulse voltage and the known value of line resistance ($5\text{ k}\Omega$) calculate the peak pulse currents for the secure signal and the alarm signal.

5.7.4 Alternating-Current Line-Carrier Technique

Connect the control unit to the annunciator panel as shown in figure 4. Set the decade resistor, R , to $0\ \Omega$, adjust the control unit as specified by the manufacturer, and measure V_1 . Check for proper secure, alarm, and line trouble operation at the annunciator panel. Reset R to $5\text{ k}\Omega$ and measure V_1 . Check for proper secure, alarm, and line trouble operation at the annunciator panel. If the control unit is capable of transmitting other ac alarm status signals, such as holdup, also perform the above transmission tests for these signals.

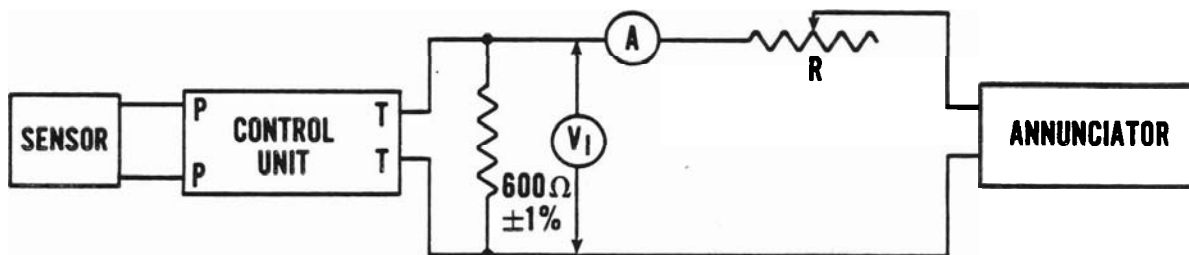

T - Transmission loop terminals
P - Protection loop terminals

FIGURE 4. Setup for alternating-current line-carrier signal transmission tests.

5.7.5 Interrogation and Reply Technique

For control units with an interrogation and reply transmission system, perform the transmission tests at both the control unit's receiver and annunciator panel receiver. Initially place the $600\text{-}\Omega$ resistor across the output terminals of the annunciator panel transmitter. Deactivate the reply transmitter in the control unit and monitor the receiver for its response to the interrogation signal. Follow the test procedure used to make sensitivity measurements for the appropriate transmission technique (sec. 5.7).

To test receiver sensitivity at the annunciator panel, place the $600\text{-}\Omega$ resistor across the output terminals of the control unit transmitter. Deactivate the transmitter in the annunciator panel. Initiate a reply transmission of the control unit and monitor the annunciator panel for its response to the reply signal. Again follow the test procedure used to make sensitivity measurements for the appropriate transmission technique (sec. 5.7). Consult the manufacturer if technical help is needed in order to perform this test.

Some interrogation and reply systems operate only with continuous signals. For these systems, both the transmitter and receiver modules must be operational at each end. Therefore, the test system should be duplicated at each end. Under test conditions the receiver sensitivity measurements can be made simultaneously instead of sequentially as described above. Consult the manufacturer if technical help is needed in order to perform this test.

5.7.6 Supplementary Line Security Technique

When two or more transmission signals are combined to increase transmission line security above that which normally can be obtained with a single transmission signal, each transmission method is tested individually but in the presence of the other signals. Initially set the decade resistor to $0\ \Omega$. With all power on, adjust the alarm signal source to a secure state and adjust the transmission signals to the levels specified by the manufacturer. Test each of the transmission methods separately as outlined in sections 5.7.1 through 5.7.5. Consult the manufacturer if technical help is needed in order to perform this test.

5.8 Stability Tests

Set up the control unit according to the instructions in this section.

5.8.1 High-Voltage Test

Connect the control unit to a variable voltage power supply. Adjust the power supply for a voltage of 110 ± 1 percent of the nominal operating voltage as specified by the manufacturer, section 4.2(a), and check for proper operation.

5.8.2 Low-Voltage Test

Using the variable voltage power supply from above, adjust for a voltage of 85 ± 1 percent of the nominal operating voltage as specified by the manufacturer, section 4.2(a), and check for proper operation.

5.8.3 Shock Test

Disconnect the control unit from the power line voltage and standby power, and place the unit on a bench with a horizontal solid wooden top at least 4-cm (1-5/8 in) thick or on a floor having at least the same rigidity as the work bench top. Using one edge of the unit as a pivot, lift the opposite edge until it forms an angle of 45° with the bench top, or the lifted edge has been raised 10 cm (4 in) above the horizontal surface, or the lifted edge is just below the point of perfect balance, whichever condition occurs first. Then let the unit drop back freely to the flat surface. Repeat, using other practical edges of the same horizontal side as the pivot edges for a total of four drops.

Repeat the entire procedure with the unit resting on other sides until it has been dropped a total of four times on each side on which the unit could be practically placed during servicing. Then test in accordance with sections 5.6 through 5.7.6.

5.8.4 High-Temperature Test

Place the control unit in an environmental chamber at a temperature of $50\pm 2^\circ\text{C}$ ($122\pm 3.6^\circ\text{F}$). Allow it to remain at that temperature for a minimum of 4 h, and then while at that test temperature, test in accordance with sections 5.6 through 5.7.6. The instrumentation, sensors, decade resistance box, and annunciator panel shall be located outside the environmental chamber. The control unit shall be arranged so that the reset switch can be actuated from outside the chamber.

5.8.5 Low-Temperature Test

Place the control unit in an environmental chamber at a temperature of $0\pm 2^\circ\text{C}$ ($32\pm 3.6^\circ\text{F}$). Allow it to remain at that temperature for a minimum of 4 h, and then while at that test temperature, test in accordance with sections 5.6 through 5.7.6. The instrumentation, sensors, decade resistance box, and annunciator panel shall be located outside the environmental chamber. The control unit shall be arranged so that the reset switch can be actuated from outside the chamber.

5.8.6 High-Humidity Test

Place the control unit in an environmental chamber at a relative humidity of 85 ± 2 percent and at a temperature of $30\pm 5^\circ\text{C}$ ($86\pm 9^\circ\text{F}$). Allow it to remain at that humidity for 24 h, and then while at the test humidity, test in accordance with sections 5.6 through 5.7.6. The instrumentation, sensors, decade resistance box, and annunciator panel shall be located outside the environmental chamber. The control unit shall be arranged so that the reset switch can be actuated from outside the chamber.

5.9 Electromagnetic Susceptibility Tests

The radiated electromagnetic susceptibility test shall be conducted in a shielded room (EMI test chamber). The conducted electromagnetic susceptibility and lightning surge tests may be performed without an EMI test chamber; however, the test site should be located away from sensitive instruments. The conducted radio-frequency signals and voltage spikes on the power lines can interfere with the operation of such instruments.

5.9.1 Conducted Electromagnetic Susceptibility Tests

Connect the control unit and annunciator as shown in figure 5. The 600-Ω resistor across the output terminals of the transmitter is used if the equipment uses an ac signal transmission technique. The fixed 510-Ω resistors are in series with each transmission wire. Adjust the transmission signal as instructed by the manufacturer for normal operation and place the control unit in a secure state. Observe whether the annunciator indicates any condition other than secure during the performance of the tests.

Subject the control unit to power line conducted interference in accordance with test methods CS01, CS02, and CS06 of MIL-STD-462 [3]. Maintain a test level of 1 or 3 V rms as required, either manually or automatically, over the entire frequency test range.

Determine the level of susceptibility of the control unit for each frequency at which the control unit transmitted other than a secure state. Manually tune the frequency at which the control unit transmitted an alarm, and raise the signal level from the lowest output level until the control unit transmits a state other than secure. Reduce the signal level 10 percent and note whether the control unit transmits a secure state. Repeat this test three or more times to determine the threshold susceptibility level, which is the signal level at which the control unit enters the alarm state when a 10-percent reduction in signal level causes the control unit to indicate a secure state.

Repeat test CS02 on the transmission lines. Couple the interference signals to the control unit side of each 510-Ω resistor (points A and B of fig. 5). Since the transmission lines are connected to the annunciator, check for any malfunctioning of the annunciator panel during the test.

Repeat test CS02 on each protection loop. Couple the interference signals across a 1-kΩ resistor placed in the protection loop (points C and D of fig. 5). The source of the test signal shall be isolated from the rest of the circuit to avoid ground loop interaction.

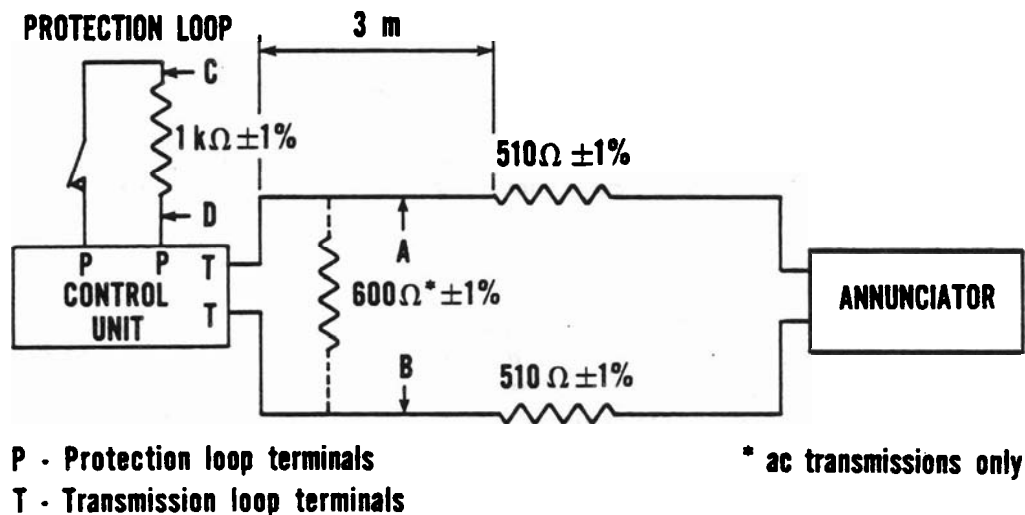

FIGURE 5. Setup for conducted and radiated susceptibility tests.

5.9.2 Radiated Electromagnetic Susceptibility Test

Connect the control unit and annunciator as shown in figure 5. The instrumentation, sensors, line resistors, and annunciator shall be located outside of the shielded room (EMI test chamber) during testing. Arrange the unit so that the reset switch can be actuated from outside of the chamber if the unit does not reset automatically.

Subject the control unit to radiation in accordance with test method RS03 of MIL-STD-462 [3]. Use an electric field of 1 V/m for frequencies in the range from 14 kHz to 2 MHz and 3 V/m for frequencies in the range from 2 MHz to 12 GHz.

Determine the susceptibility of the unit for each frequency or frequency band at which the unit signals an alarm or line trouble. The susceptibility level is that for which the unit will not signal an alarm for a 10-percent reduction in signal level from the level that does cause an alarm. Monitor the annunciator for any malfunctions during testing. Determine whether the alarm signals are originating in the control unit or in the annunciator.

5.9.3 Lightning Surge Test

Connect the lightning surge test circuit to the oscilloscope, with the output of the circuit terminated in a 600-Ω resistor as shown in figure 6. Operate the circuit and examine the pulse shape. If necessary, change the values of the nominal 33-Ω resistor and 0.1-μF capacitor to get a 600 ± 30 -V pulse with a rise time of 10 ± 2 μs and a decay time to one-half maximum of 1.6 ± 0.2 ms.

Connect the control unit and annunciator as shown in figure 6. Place the control unit in the secure state. Remove the 600-Ω terminating resistor and connect the lightning simulation test circuit across transmission lines at points A and B. Apply five test surges of each polarity to the control unit, with at least a 15-s interval between surges to insure that the 3.3-μF capacitor in the pulse circuit is fully charged. Reconnect the 600-Ω terminating resistor across the output of the lightning simulation test circuit and repeat the test with the lightning surge simulator circuit connected between ground and, respectively, points A and B. Record any alarm or line trouble indications.

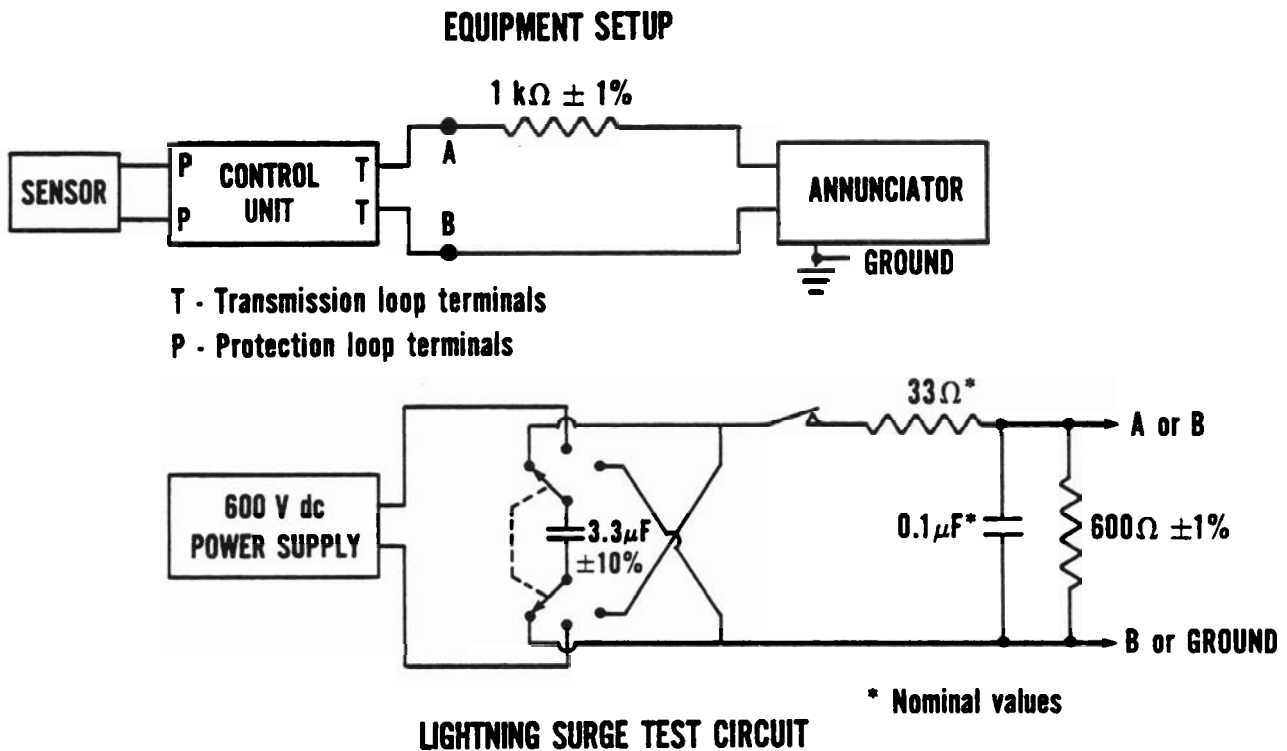

FIGURE 6. Equipment setup and lightning surge generation circuit for lightning surge test.

5.10 Tamper Switch Test

If the control unit has a hinged cover, swing it open until the tamper switch is first actuated, and measure the displacement of the cover opposite the hinge. If the unit has a nonhinged cover, lift one side until the tamper switch first actuates, and measure the displacement of that side of the cover. Repeat this for each of the other three sides. If an unhinged cover cannot be lifted one side at a time, then lift or move it uniformly until the tamper switch first actuates, and measure the movement of the cover. If the device has a tamper switch actuated by the motion of a cover screw, retract the screw until the tamper switch is actuated, and measure the displacement of the screw.

In each instance examine the unit while the cover is lifted to the position just sufficient to actuate the tamper switch, and determine if there is a direct line-of-sight to any internal adjustment control or electrical circuitry.

5.11 Standby Power Operation Test

While operating the control unit from the ac power line, disrupt the ac power and permit the control unit to operate from its fully-charged standby power supply. Observe whether it signals an alarm, wait 1 min, reconnect the ac power, and again observe whether it signals an alarm. Repeat this connect and disconnect test two additional times. Then allow the unit to operate continuously from the standby power supply for the period of time specified by the manufacturer in accordance with sec. 4.2(f). Upon completion of the required operating period, test the unit in accordance with sections 5.6 through 5.7.6 while still operating on the standby power.

If the unit incorporates a battery charging circuit, connect it to line voltage and again test the unit in accordance with sections 5.6 through 5.7.6. Allow it to operate continuously for the period of time specified by the manufacturer as required to fully charge the batteries [sec. 4.2(g)] and then repeat the standby power operation test as described in the preceding section.

5.12 Local Alarm Annunciator Device Control Test

If a contact closure is provided, determine the contact rating from the relay type. If a voltage output is provided, measure the open circuit voltage with the control circuit actuated. If this voltage is 12-V dc or more connect a 6- Ω resistor (at least 25 W) across the output terminals and again measure the output voltage.

APPENDIX A—REFERENCES

- [1] Police station connected burglar alarm units and systems. 1st ed. UL Standard 365; 1979 February 16. Underwriters' Laboratories, Inc., 333 Pfingsten Road, Northbrook, IL 60062.
- [2] Direct connect police annunciator panels. NIJ Standard-0320.00. National Institute of Justice, U.S. Department of Justice, Washington, DC 20531.
- [3] Measurements of electromagnetic interference characteristics. MIL-STD-462; 1968 August 1 and Notice 3, 1971 February 9. Naval Publication and Form Center, 5801 Tabor Avenue, Philadelphia, PA 19120.