



U.S. Department
of Transportation
**Federal Highway
Administration**

March 19, 2009

1200 New Jersey Ave., S.E.
Washington, DC 20590

In reply to: HSSD/WZ-277

Mr. Marc Christensen
Off the Wall Products, LLC
P.O. Box 1461
Salt Lake City, UT 84110

Dear Mr. Christensen:

In your letter of January 29 you requested the Federal Highway Administration (FHWA) acceptance of the modified and re-designed Multi Barrier Model MB 42 x 72 JSS longitudinal channelizing device as a crashworthy traffic control devices for use in work zones on the National Highway System (NHS). Accompanying your letter was the FHWA Office of Safety Design form, a drawing of the device, and a detailed description of previous testing you completed on a similar longitudinal channelizing device (WZ-255). The drawing and detailed description are enclosed with the acceptance form for the re-designed Multi Barrier Model MB 42 x 72 JSS longitudinal channelizing device. The re-designed device is intended for use with no more than 41 liters (10.8 gallons) of water in each module as ballast. You requested that we find this device acceptable for use on the NHS under the provisions of the National Cooperative Highway Research Program Report 350, "Recommended Procedures for the Safety Performance Evaluation of Highway Features".

This letter is the acknowledgement of the FHWA's acceptance of your requests. Longitudinal channelizers should not be described as "barriers" because they do not meet crashworthiness requirements for redirection. A suggested example for labeling each unit or module to indicate limitations of use are enclosed. The original completed forms have been modified by the addition of the FHWA acceptance letter number and the date of our review. The form will be posted on our Web site in the near future.

Sincerely yours,

David A. Nicol, P.E.
Director, Office of Safety Design
Office of Safety

Enclosures

MOVING THE
AMERICAN
ECONOMY

Attachment 1

Page 1	FEDERAL HIGHWAY ADMINISTRATION OFFICE OF SAFETY DESIGN	Letter Number
	Category 2 Work Zone Device Acceptance Letter	Date
Contact Info	Petitioner / Developer Name and Address:	
	Marc Christensen, Manager, Off the Wall Products LLC PO Box 1461 Salt Lake City UT 84110	
	I hereby certify that the device(s) covered by this Acceptance Letter meet(s) the crash – worthiness test and evaluation requirements of the FHWA and NCHRP Report 350.	
Signature	Marc Christensen <small>Digitally signed by Marc Christensen DN: cn=Marc Christensen, o=Off the Wall Products LLC, email=marc@otwsafety.com Reason: I agree to the terms outlined in the statement of my signature on this document. Date: 2009.05.01 13:25:08 -0700</small>	
Telephone #	(801) 363-7740	
Email Address	marc@otwsafety.com	
	Laboratory / Engineer Name and Address	
	Lifetime Plastics, Ed Vannimwegen, Engineer Freeport Center Bldg D11 Clearfield UT 84016	
<input checked="" type="checkbox"/>	I hereby certify that the testing that supports this Acceptance Letter was conducted in accordance with NCHRP Report 350 guidelines, that the device(s) tested is/are accurately described on this form, and that the test results indicate that the device meets all applicable NCHRP Report 350 evaluation criteria.	
<input checked="" type="checkbox"/>	I have evaluated the requested modifications to these devices previously found acceptable by the FHWA in Acceptance Letter WZ-___, and hereby certify that, in my opinion, the modifications do not adversely affect the crash performance of the devices. I also certify that these devices are accurately described on this form.	
Signature	Marc Christensen <small>Digitally signed by Marc Christensen DN: cn=Marc Christensen, o=Off the Wall Products LLC, email=marc@otwsafety.com Date: 2009.05.01 13:25:08 -0700</small>	
Telephone #	(801) 728-1342	
Email Address	EVannimwegen@lifetime.com	
Keywords:	WZ-255, WZ-277, MB42x72 JSS LCB, Longitudinal Channelizing Device	
	Type of Device (See page 3) Channelizer (Individual units unlike cones, road tubes, or drums) Composition of Sign or Rail substrate (See Page 3)	
	Thickness of substrate (inches):	
	Height of sign from the ground (inches), if applicable: (See Page 3)	
	Flags and or lights present during test? Indicate number of each:	
	# of flags:	# of lights: 0 Weight of lights: ea.
Device Name	Multi-Barrier Model MB42x72 JSS LCB	
Detailed Desc. Of Device, Materials, sizes, Fasteners, Substrates Foundation, Aux. Features Ballast, etc.	(May be attached on separate page(s) 42" high x 72" long x 24" wide Jersey Safety Shape barricade. Approximately 90 pounds orange Hi Density polyethylene with nominal wall thickness of .156 inches. Includes fill cap, drain plug, fork lift slots, and positions for lights and screens.	

Attachment 1

Page 2	FEDERAL HIGHWAY ADMINISTRATION OFFICE OF SAFETY DESIGN Category 2 Work Zone Device Acceptance Letter		Letter Number
			Date
	Mandatory Attachments		
	Attachment # 1: Test data summary page(s)		
	Attach. #1a	Test #	
	Attach. #1b	Test #	
	Attach. #1c	Test #	
	Attach. #1d	Test #	
Alternative	Attachment # 1: Description and discussion of modification(s) to crash tested and/or accepted device.		
	Date: 03/02/2009		
	Attachment # 2: PDF drawing(s) of device(s)		
	Attach. #2a	Drawing Title: PD0636 BARRICADE NARROW TLA	
		Drawing #: 2	
	Attach. #2b	Drawing Title:	
		Drawing #:	
	Attach. #2c	Drawing Title:	
		Drawing #:	
	Attach. #2d	Drawing Title:	
		Drawing #:	
	Attach. #2e	Drawing Title:	
		Drawing #:	
	Attach. #2f	Drawing Title:	
		Drawing #:	
	Attach. #2g	Drawing Title:	
		Drawing #:	

Attachment 1

Page 3	FEDERAL HIGHWAY ADMINISTRATION OFFICE OF SAFETY DESIGN Category 2 Work Zone Device Acceptance Letter	Letter Number
		Date

Please select from the following Keywords for "Type of Device":

Longitudinal Channelizing Barricade
 Curb (Curb channelizer system with or without road tubes or other channelizers)
 Drum
 H-Footprint Sign Stand
 X-Footprint Sign Stand
 Trailer Mounted Signs (Does not include arrow boards or variable message signs or other Category 4 trailer mounted devices.)
 Automated Flagger Device (not trailer mounted)
 Tripod Sign Stand
 Type I Barricade
 Type II Barricade
 Type III Barricade
 Vertical Panel
 Intrusion Detector
 Ballast (Action relates to ballast on one or more devices)
 Channelizer (Individual units unlike cones, road tubes, or drums)

Please select from the following Keywords for "Sign Substrate":

Roll-up / Fabric (with fiberglass spreaders – aluminum or steel spreaders are not allowed.)
 Plywood
 Aluminum – Solid
 Aluminum – Laminate
 Corrugated Plastic
 Extruded Plastic
 Waffleboard Plastic
 Wood / Lumber

Please select from the following Keywords for "Height of Sign":

The distance to the lowest point on the sign is:

Low 12 to 18 inches above the pavement
 Mid-A 20 to 24 inches above the pavement
 Mid-B 25 to 36 inches above the pavement
 Mid-C 37 to 59 inches above the pavement
 Tall 60 to 71 inches above the pavement
 Oversized 72 inches and taller

Attachment 1

Page 4	FEDERAL HIGHWAY ADMINISTRATION OFFICE OF SAFETY DESIGN Category 2 Work Zone Device Acceptance Letter		Letter Number
			Date

Please note the following standard provisions that apply to FHWA letters of acceptance:

- Our acceptance is limited to the crashworthiness characteristics of the devices and does not cover their structural features, or conformity with the Manual on Uniform Traffic Control Devices.
- Any changes that may adversely influence the crashworthiness of the device will require a new acceptance letter.
- Should the FHWA discover that the qualification testing was flawed, that in-service performance reveals unacceptable safety problems, or that the device being marketed is significantly different from the version that was crash tested, it reserves the right to modify or revoke its acceptance.
- You will be expected to supply potential users with sufficient information on design and installation requirements to ensure proper performance.
- You will be expected to certify to potential users that the hardware furnished has essentially the same chemistry, mechanical properties, and geometry as that submitted for acceptance, and that they will meet the crashworthiness requirements of FHWA and NCHRP Report 350.
- To prevent misunderstanding by others, this letter of acceptance shall not be reproduced except in full. This letter, and the test documentation upon which this letter is based, is public information. All such letters and documentation may be reviewed at our office upon request.
- If the subject of this letter is a patented device it is considered "proprietary." The use of proprietary work zone traffic control devices in Federal-aid projects is generally of a temporary nature. They are *selected by the contractor* for use as needed and removed upon completion of the project. Under such conditions they can be presumed to meet requirement "a" given below for the use of proprietary products on Federal-aid projects. On the other hand, if proprietary devices are *specified by a highway agency* for use on Federal-aid projects they: (a) must be supplied through competitive bidding with equally suitable unpatented items; (b) the highway agency must certify that they are essential for synchronization with existing highway facilities or that no equally suitable alternative exists or; (c) they must be used for research or for a distinctive type of construction on relatively short sections of road for experimental purposes. Our regulations concerning proprietary products are contained in Title 23, Code of Federal Regulations, Section 635.411, a copy of which is enclosed.
- This Acceptance Letter shall not be construed as authorization or consent by the Federal Highway Administration to use, manufacture, or sell any patented device for which the applicant is not the patent holder. The Acceptance Letter is limited to the crashworthiness characteristics of the candidate device, and the FHWA is neither prepared nor required to become involved in issues concerning patent law. Patent issues, if any, are to be resolved by the applicant.

WZ-277 Attachment #1: Description and discussion of modification to crash tested and accepted device.

The tested LCB Model MB42x72 JSS LCB is 2 interconnected pieces, 42 high, 35 1/2 long, and 24 wide, for a total tested dimension of 42 high, 72 long, and 24 wide. The modified unit is one piece 72 long, 42 high, and 24 wide. We have eliminated the dog bone connection device in lieu of a one piece design. Essentially the weights and dims are the same. The water weight on the tested unit is poured into two chambers. The new unit is one single chamber with the same volume. The only difference is the connection.

We have eliminated the pin and doughnut connection as it will not come apart easily when lifted from the bottom in the back of a truck or in a work zone. The pin actually causes the water cell to rupture when lifted from the end. We have gone back to the same locating system we have used on the MB42x45 LCB (WZ-214). This system cannot actually lock together, either intentionally or unintentionally, so has the added benefit of gating without the possibility of locking when struck by a vehicle.

The dimensions are identical:

Height: 42" / 107 cm

Length: 72" / 183 cm

Width: 24" / 61 cm

Wall: 0.22" / 5.6 mm

The material is also the same, HDPE with UV inhibitor and orange color additive.

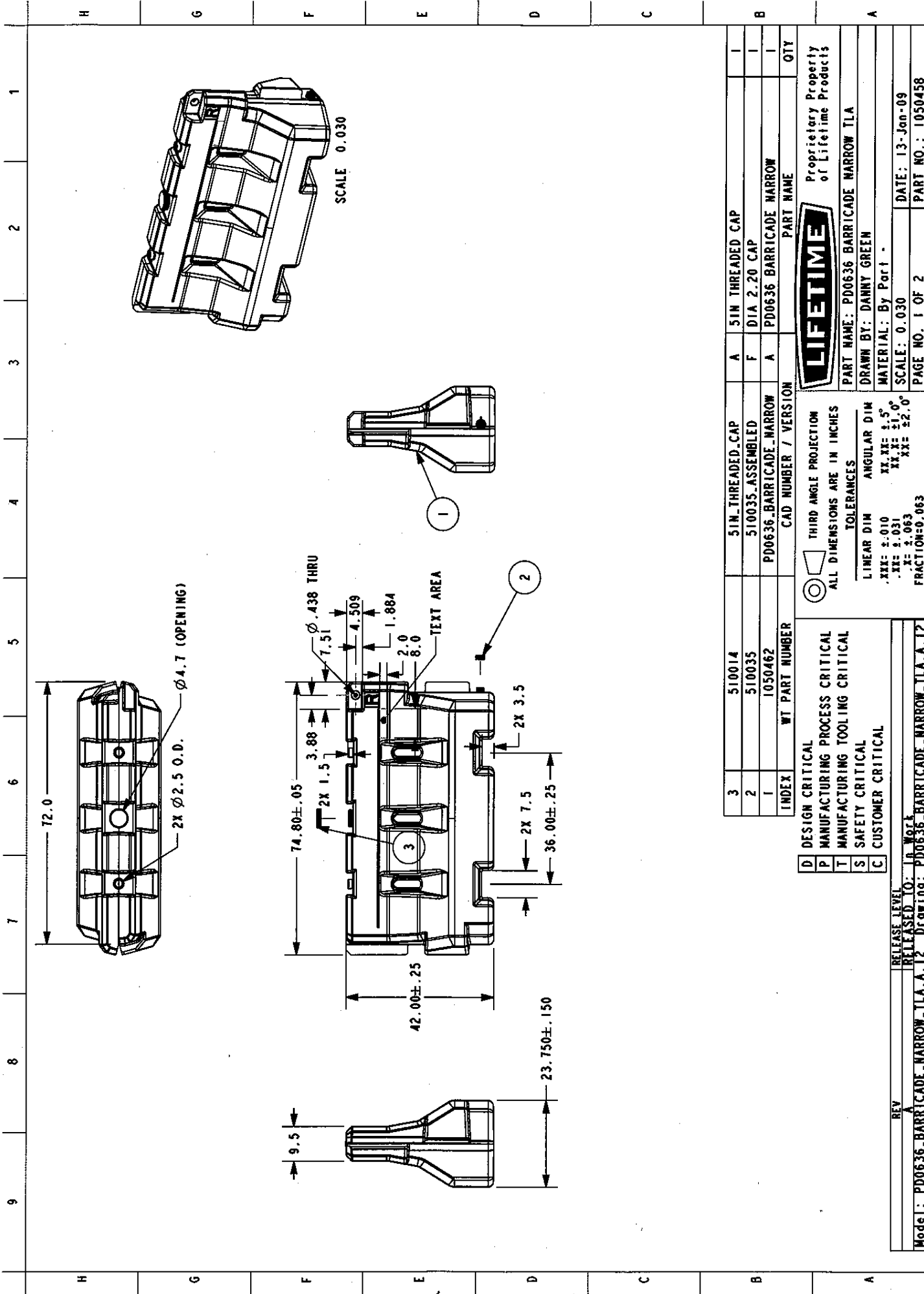

3	510014	51N_THREADED_CAP	A	51N THREADED CAP	1
2	510035	510035_ASSEMBLED	F	DIA 2.20 CAP	1
1	1050462	PD0636_BARRICADE_NARROW	A	PD0636 BARRICADE NARROW	1
INDEX		WT PART NUMBER	CAD NUMBER / VERSION		PART NAME
D	DESIGN CRITICAL				
P	MANUFACTURING PROCESS CRITICAL				
T	MANUFACTURING TOOLING CRITICAL				
S	SAFETY CRITICAL				
C	CUSTOMER CRITICAL				
<p>THIRD ANGLE PROJECTION ALL DIMENSIONS ARE IN INCHES TOLERANCES LINEAR DIM ANGLUAR DIM .XXX: ±.010 XX XX: ±.5° .XX: ±.031 XX XX: ±1.0° .X: ±.063 XX XX: ±2.0° FRACTION: 9.063</p>					
<p>RELEASE LEVEL: A REV: A RELEASED TO: J. Vork Model: PD0636_BARRICADE_NARROW_TLA.A.12 Drawing: PD0636_BARRICADE_NARROW_TLA.A.12</p>					
<p>PART NAME: PD0636 BARRICADE NARROW TLA DRAWN BY: DANNY GREEN MATERIAL: By Part SCALE: 0.030 DATE: 13-Jan-09 PAGE NO. 1 OF 2 PART NO.: 1050458</p>					
<p>LIFETIME Proprietary Property of Lifetime Products</p>					

1 2 3 4 5 6 7 8 9

H G F E D C B A

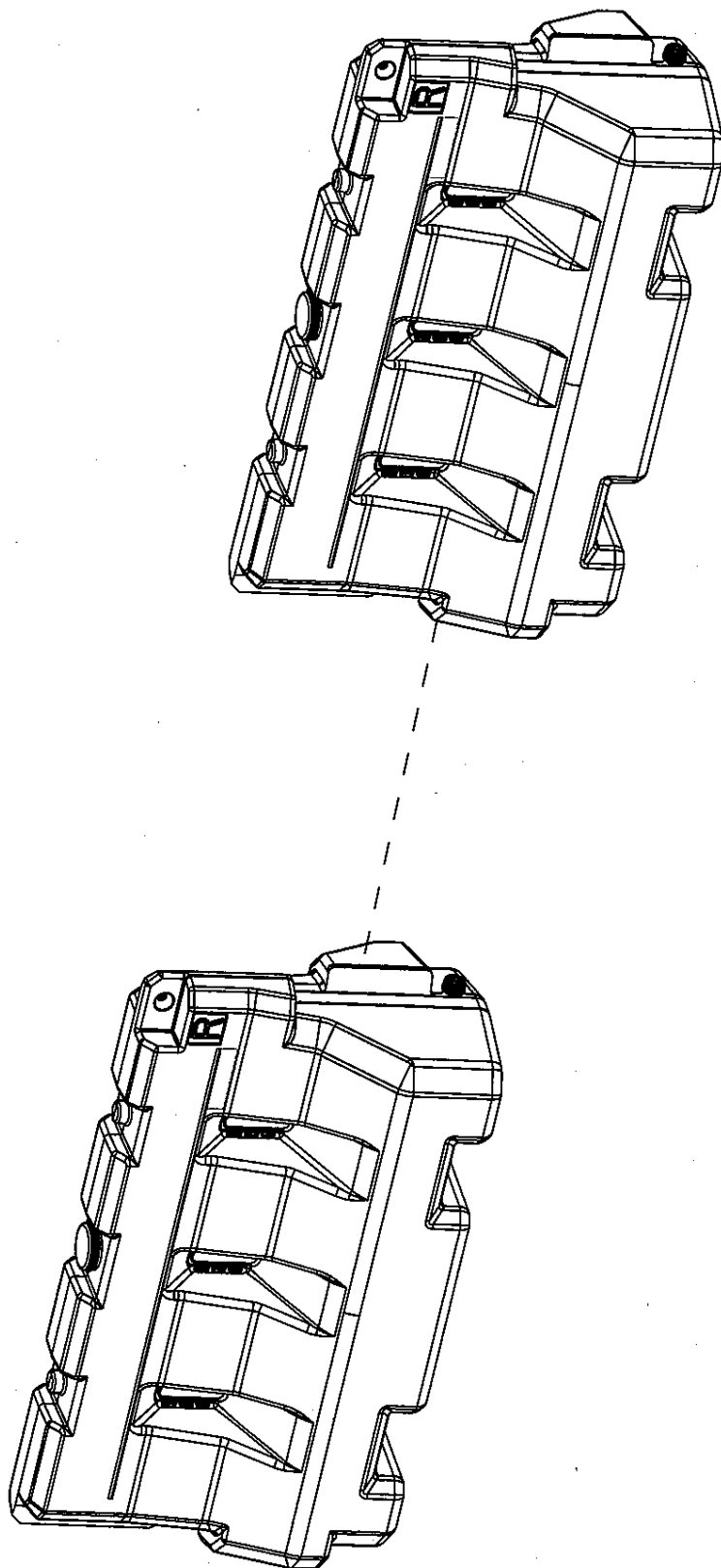

VIEW:
2 UNITS CONNECTING

LIFETIME Proprietary Property of Lifetime Products

PART NAME: PD0636 BARRICADE NARROW TLA
 DRAWN BY: DANNY GREEN
 MATERIAL: By Part
 SCALE: 0.050
 DATE: 09-Jan-09
 PAGE NO. 2 OF 2
 PART NO.: 1050458

THIRD ANGLE PROJECTION
 ALL DIMENSIONS ARE IN INCHES

TOLEANCES

LINEAR DIM	ANGULAR DIM
.XXX: ±.010	XX: ±.5°
.XX: ±.031	XX: ±1.0°
.X: ±.063	XX: ±2.0°

FRACTION=0.063

- D DESIGN CRITICAL
- P MANUFACTURING PROCESS CRITICAL
- T MANUFACTURING TOOLING CRITICAL
- S SAFETY CRITICAL
- C CUSTOMER CRITICAL

BEV
 RELEASE LEVEL
 Model: PD0636-BARRICADE-NARROW-TLA-A-12
 Drawing: PD0636-BARRICADE-NARROW-TLA-A-12

H G F E D C B A

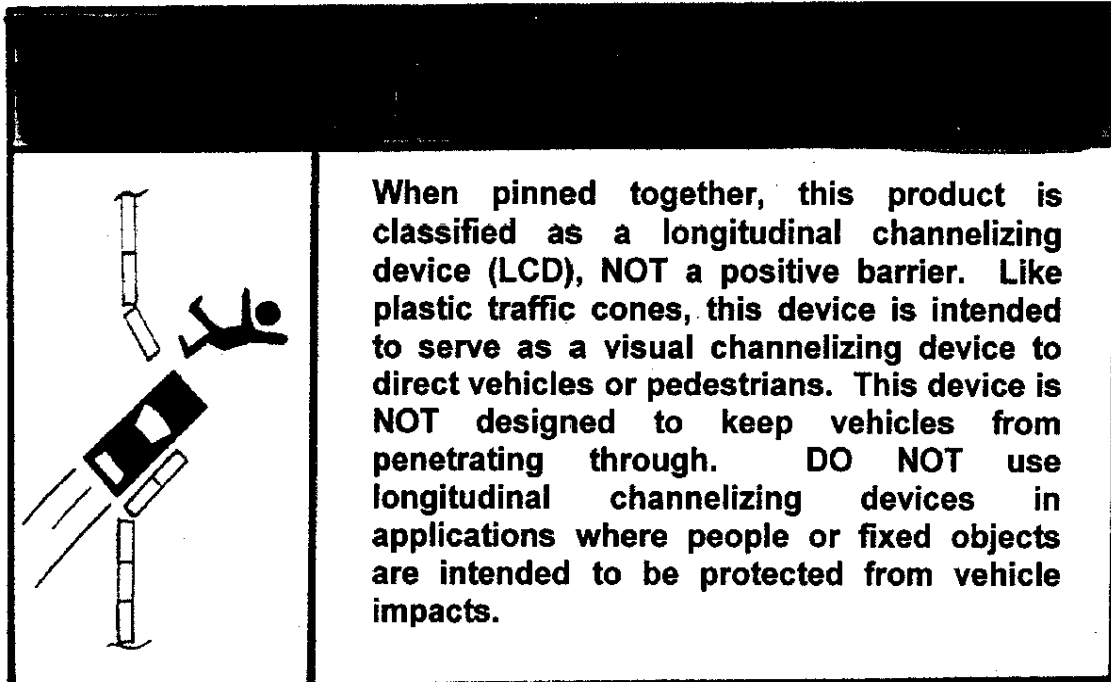

Example of a possible Plastic Water-Filled Longitudinal Channelizing Device (LCD) Decal