



US00D880437S

(12) **United States Design Patent**
Lee et al.

(10) **Patent No.:** **US D880,437 S**
(45) **Date of Patent:** **** Apr. 7, 2020**

(54) **GAS SUPPLY PLATE FOR SEMICONDUCTOR MANUFACTURING APPARATUS**

(71) Applicant: **ASM IP Holding B.V.**, Almere (NL)

(72) Inventors: **Hak Joo Lee**, Gyeonggi-do (KR); **Jeong Jun Woo**, Chungcheongnam-do (KR); **Jong Hyun Ahn**, Gyeonggi-do (KR); **Yoon Ki Min**, Seoul (KR)

(73) Assignee: **ASM IP Holding B.V.**, Almere (NL)

(**) Term: **15 Years**

(21) Appl. No.: **29/646,377**

(22) Filed: **May 3, 2018**

(30) **Foreign Application Priority Data**

Feb. 1, 2018 (KR) 30-2018-0005758

(51) **LOC (12) Cl.** **13-03**

(52) **U.S. Cl.**
USPC **D13/182**

(58) **Field of Classification Search**
USPC D13/182; D23/213

(Continued)

(56) **References Cited**

U.S. PATENT DOCUMENTS

D30,036 S 1/1899 Rhind
D31,889 S 11/1899 Gill

(Continued)

FOREIGN PATENT DOCUMENTS

CN 2588350 11/2003
CN 1563483 1/2005

(Continued)

OTHER PUBLICATIONS

USPTO; Office Action dated Aug. 27, 2010 in U.S. Appl. No. 12/118,596.

(Continued)

Primary Examiner — Elizabeth J Oswecki

(74) *Attorney, Agent, or Firm* — Snell & Wilmer L.L.P.

(57) **CLAIM**

The ornamental design for a gas supply plate for semiconductor manufacturing apparatus, as shown and described.

DESCRIPTION

FIG. 1 is a perspective view of a gas supply plate for semiconductor manufacturing apparatus showing my new design;

FIG. 2 is a front elevational view thereof;

FIG. 3 is a rear elevational view thereof;

FIG. 4 is a left side elevational view thereof;

FIG. 5 is a right side elevational view thereof;

FIG. 6 is a top plan view thereof;

FIG. 7 is a bottom plan view thereof;

FIG. 8 is an enlarged view of the portion labeled "FIG. 8" indicated in FIG. 6;

FIG. 9 is an enlarged view of the portion labeled "FIG. 9" indicated in FIG. 7; and,

FIG. 10 is a cross sectional view taken along line 10-10 in FIG. 9.

The even dashed broken lines shown in the drawings represent portions of the gas supply plate for semiconductor manufacturing apparatus that form no part of the claimed design. The dashed-dot-dashed lines represent the boundary of the claimed portions and unclaimed portions of the claimed design. The claimed portion is directed to the solid circles shown within the dashed-dot-dashed lines, which appear at the center region of the gas supply plate.

1 Claim, 6 Drawing Sheets

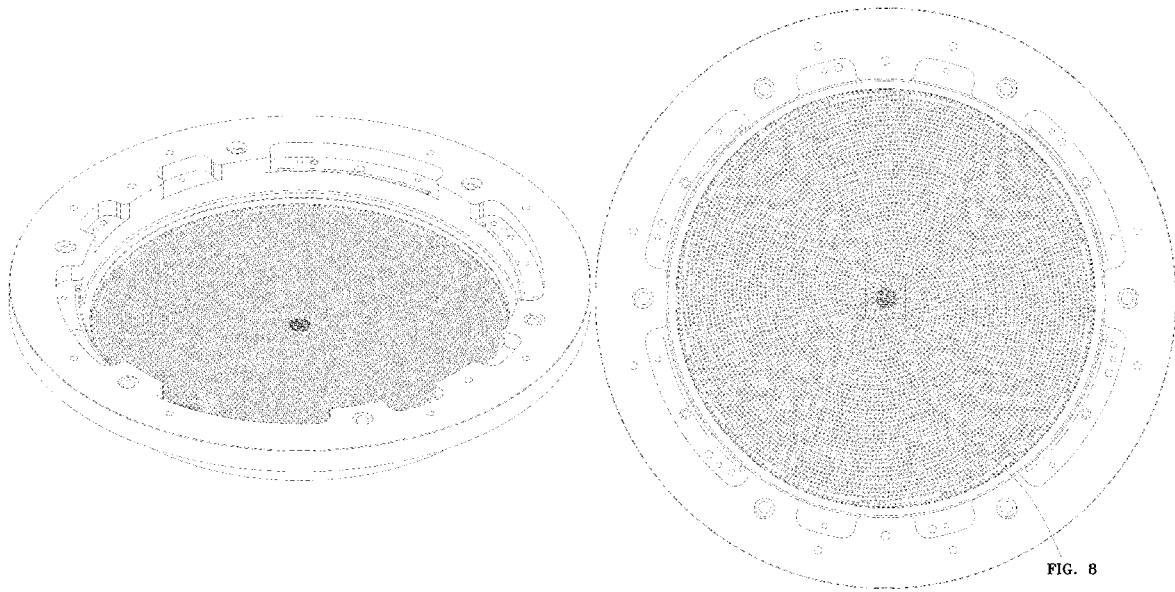

(58) **Field of Classification Search**

CPC H01J 37/32623; H01J 37/32633; H01J 37/32642; H01J 37/32; H01J 37/3244; H01J 37/32449; H01L 21/67; H01L 21/67011; H01L 21/67063; H01L 21/67069; H01L 21/6708; H01L 21/68098; H01L 21/67109; H01L 21/6875; H01L 21/68714; F27B 15/00; F27B 15/006; F27B 15/10; C30B 31/10; C30B 31/16; C30B 31/165; C30B 31/14; C30B 33/12; F27D 5/00; F27D 5/0037; F27D 7/02; F27D 7/00; F27D 7/023; G21D 9/673; G21D 9/675; G21D 9/677; G21D 9/42; G21D 9/54; G21D 9/0025; B21C 47/26; C23C 16/4412; C23C 16/44; C23C 16/4401; C23C 16/4402; C23C 16/4404; C23C 16/4405; C23C 16/4408; C23C 16/455; C23C 16/45517; C23C 16/45519; C23C 16/45521; C23C 16/45559; C23C 16/45563; C23C 16/45565; C23C 16/45568; C23C 16/4557; C23C 16/45587; C23C 16/458; C23C 16/4581; C23C 16/4582; C23C 16/4584; C23C 16/46; C23C 16/466

See application file for complete search history.

(56) **References Cited**

U.S. PATENT DOCUMENTS

D56,051 S 8/1920 Cohn
 2,059,480 A 11/1936 Obermaier
 2,161,626 A 6/1939 Loughner et al.
 2,266,416 A 12/1941 Duclos
 2,280,778 A 4/1942 Anderson
 D142,841 S * 11/1945 D'Algodt D23/213
 2,410,420 A 11/1946 Bennett
 2,563,931 A 8/1951 Harrison
 2,660,061 A 11/1953 Lewis
 2,745,640 A 5/1956 Cushman
 2,990,045 A 9/1959 Root
 3,038,951 A 6/1962 Mead
 3,089,507 A 5/1963 Drake et al.
 3,094,396 A 6/1963 Flugge et al.
 3,232,437 A 2/1966 Hultgren
 3,263,502 A 8/1966 Springfield
 3,410,349 A 11/1968 Troutman
 3,588,192 A 6/1971 Drutchas et al.
 3,647,387 A 3/1972 Benson
 3,647,716 A 3/1972 Koches
 3,713,899 A 1/1973 Sebestyen
 3,718,429 A 2/1973 Williamson
 3,833,492 A 9/1974 Bollyky
 3,854,443 A 12/1974 Baerg
 3,862,397 A 1/1975 Anderson et al.
 3,867,205 A 2/1975 Schley
 3,885,504 A 5/1975 Baermann
 3,887,790 A 6/1975 Ferguson
 3,904,371 A 9/1975 Neti
 3,913,058 A 10/1975 Nishio et al.
 3,913,617 A 10/1975 van Laar
 3,947,685 A 3/1976 Meinel
 3,960,559 A 6/1976 Suzuki
 3,997,638 A 12/1976 Manning et al.
 4,054,071 A 10/1977 Patejak
 4,058,430 A 11/1977 Suntola et al.
 4,093,491 A 6/1978 Whelpton et al.
 D249,341 S 9/1978 Mertz
 4,126,027 A 11/1978 Smith et al.
 4,134,425 A 1/1979 Gussefeld et al.
 4,145,699 A 3/1979 Hu et al.
 4,164,959 A 8/1979 Wurzburger
 4,176,630 A 12/1979 Elmer

4,181,330 A 1/1980 Kojima
 4,194,536 A 3/1980 Stine et al.
 4,217,463 A 8/1980 Swearingen
 4,234,449 A 11/1980 Wolson et al.
 4,322,592 A 3/1982 Martin
 4,333,735 A 6/1982 Hardy
 4,355,912 A 10/1982 Haak
 4,389,973 A 6/1983 Suntola et al.
 4,393,013 A 7/1983 McMenamin
 4,401,507 A 8/1983 Engle
 4,414,492 A 11/1983 Hanlet
 4,436,674 A 3/1984 McMenamin
 4,444,990 A 4/1984 Villar
 4,454,370 A 6/1984 Voznick
 4,455,193 A 6/1984 Jeuch et al.
 4,466,766 A 8/1984 Geren et al.
 4,479,831 A 10/1984 Sandow
 4,499,354 A 2/1985 Hill et al.
 4,512,113 A 4/1985 Budinger
 4,527,005 A 7/1985 McKelvey et al.
 4,537,001 A 8/1985 Uppstrom
 4,548,688 A 10/1985 Mathews
 4,570,328 A 2/1986 Price et al.
 4,575,636 A 3/1986 Caprari
 4,578,560 A 3/1986 Tanaka et al.
 4,579,378 A 4/1986 Snyders
 4,579,623 A 4/1986 Suzuki et al.
 4,590,326 A 5/1986 Wolody
 4,611,966 A 9/1986 Johnson
 4,620,998 A 11/1986 Lalvani
 D288,556 S 3/1987 Wallgren
 4,653,541 A 3/1987 Oehlschlaeger et al.
 4,654,226 A 3/1987 Jackson et al.
 4,664,769 A 5/1987 Cuomo et al.
 4,681,134 A 7/1987 Paris
 4,718,637 A 1/1988 Contin
 4,721,533 A 1/1988 Phillippi et al.
 4,722,298 A 2/1988 Rubin et al.
 4,724,272 A 2/1988 Raniere et al.
 4,735,259 A 4/1988 Vincent
 4,749,416 A 6/1988 Greenspan
 4,753,192 A 6/1988 Goldsmith et al.
 4,753,856 A 6/1988 Haluska et al.
 4,756,794 A 7/1988 Yoder
 4,771,015 A 9/1988 Kanai
 4,780,169 A 10/1988 Stark et al.
 4,789,294 A 12/1988 Sato et al.
 4,821,674 A 4/1989 deBoer et al.
 4,827,430 A 5/1989 Aid et al.
 4,830,515 A 5/1989 Cortes
 4,837,113 A 6/1989 Luttmer et al.
 4,837,185 A 6/1989 Yau et al.
 4,854,263 A 8/1989 Chang et al.
 4,854,266 A 8/1989 Simson et al.
 4,857,137 A 8/1989 Tashiro et al.
 4,857,382 A 8/1989 Sheng et al.
 4,882,199 A 11/1989 Sadoway et al.
 4,916,091 A 4/1990 Freeman et al.
 4,934,831 A 6/1990 Volbrecht
 4,949,848 A 8/1990 Kos
 D311,126 S 10/1990 Crowley
 4,976,996 A 12/1990 Monkowski et al.
 4,978,567 A 12/1990 Miller
 4,984,904 A 1/1991 Nakano et al.
 4,985,114 A 1/1991 Okudaira
 4,986,215 A 1/1991 Yamada
 4,987,856 A 1/1991 Hey
 4,989,992 A 2/1991 Pai
 4,991,614 A 2/1991 Hammel
 5,013,691 A 5/1991 Lory et al.
 5,027,746 A 7/1991 Frijlink
 5,028,366 A 7/1991 Harakal et al.
 5,057,436 A 10/1991 Ball
 5,060,322 A 10/1991 Delepine
 5,061,083 A 10/1991 Grimm et al.
 5,062,386 A 11/1991 Christensen
 5,065,698 A 11/1991 Koike
 5,071,258 A 12/1991 Usher et al.
 5,074,017 A 12/1991 Toya et al.

(56)

References Cited

U.S. PATENT DOCUMENTS

5,098,638	A	3/1992	Sawada	5,531,835	A	7/1996	Fodor et al.
5,098,865	A	3/1992	Machado	5,540,898	A	7/1996	Davidson
5,104,514	A	4/1992	Quartarone	5,558,717	A	9/1996	Zhao et al.
5,108,192	A	4/1992	Mailliet et al.	5,559,046	A	9/1996	Oishi et al.
5,116,018	A	5/1992	Friemoth et al.	5,574,247	A	11/1996	Nishitani et al.
D327,534	S	6/1992	Manville	5,576,629	A	11/1996	Turner
5,119,760	A	6/1992	McMillan et al.	5,577,331	A	11/1996	Suzuki
5,130,003	A	7/1992	Conrad	5,583,736	A	12/1996	Anderson et al.
5,137,286	A	8/1992	Whitford	5,589,002	A	12/1996	Su
5,154,301	A	10/1992	Kos	5,589,110	A	12/1996	Motoda et al.
5,158,128	A	10/1992	Inoue et al.	5,595,606	A	1/1997	Fujikawa et al.
5,167,716	A	12/1992	Boitnott et al.	5,601,641	A	2/1997	Stephens
5,176,451	A	1/1993	Sasada	5,604,410	A	2/1997	Vollkommer et al.
5,178,682	A	1/1993	Tsukamoto et al.	5,616,264	A	4/1997	Nishi et al.
5,181,779	A	1/1993	Shia et al.	5,616,947	A	4/1997	Tamura
5,183,511	A	2/1993	Yamazaki et al.	5,621,982	A	4/1997	Yamashita
5,192,717	A	3/1993	Kawakami	5,632,919	A	5/1997	MacCracken et al.
5,194,401	A	3/1993	Adams et al.	D380,527	S	7/1997	Velez
5,199,603	A	4/1993	Prescott	5,656,093	A	8/1997	Burkhart et al.
5,213,650	A	5/1993	Wang et al.	5,663,899	A	9/1997	Zvonar et al.
5,221,556	A	6/1993	Hawkins et al.	5,665,608	A	9/1997	Chapple-Sokol et al.
5,225,366	A	7/1993	Yoder et al.	5,679,215	A	10/1997	Barnes et al.
5,226,383	A	7/1993	Bhat	5,681,779	A	10/1997	Pasch et al.
5,228,114	A	7/1993	Suzuki	5,683,517	A	11/1997	Shan
5,242,539	A	9/1993	Kumihashi et al.	5,695,567	A	12/1997	Kordina
5,243,195	A	9/1993	Nishi	5,697,706	A	12/1997	Ciaravino et al.
5,243,202	A	9/1993	Mori et al.	5,700,729	A	12/1997	Lee et al.
5,246,218	A	9/1993	Yap et al.	5,708,825	A	1/1998	Sotomayor
5,246,500	A	9/1993	Samata et al.	5,711,811	A	1/1998	Suntola et al.
5,259,881	A	11/1993	Edwards et al.	5,716,133	A	2/1998	Hosokawa et al.
5,266,526	A	11/1993	Aoyama	5,718,574	A	2/1998	Shimazu
5,271,967	A	12/1993	Kramer et al.	D392,855	S	3/1998	Pillow
5,278,494	A	1/1994	Obigane	5,724,748	A	3/1998	Brooks
5,284,519	A	2/1994	Gadgil	5,728,223	A	3/1998	Murakami et al.
5,288,684	A	2/1994	Yamazaki et al.	5,730,801	A	3/1998	Tepman et al.
5,294,778	A	3/1994	Carman et al.	5,732,744	A	3/1998	Barr et al.
5,306,666	A	4/1994	Izumi	5,736,314	A	4/1998	Hayes et al.
5,306,946	A	4/1994	Yamamoto	5,753,835	A	5/1998	Gustin
5,310,456	A	5/1994	Kadomura	5,761,328	A	6/1998	Solberg et al.
5,314,570	A	5/1994	Ikegaya et al.	5,777,838	A	7/1998	Tamagawa et al.
5,315,092	A	5/1994	Takahashi et al.	5,779,203	A	7/1998	Edlinger
5,326,427	A	7/1994	Jerbic	5,781,693	A	7/1998	Balance et al.
5,336,327	A	8/1994	Lee	5,782,979	A	7/1998	Kaneno
5,354,580	A	10/1994	Goela et al.	5,791,782	A	8/1998	Wooten et al.
5,356,478	A	10/1994	Chen et al.	5,792,272	A	8/1998	Van Os et al.
5,356,672	A	10/1994	Schmitt et al.	5,796,074	A	8/1998	Edelstein et al.
5,360,269	A	11/1994	Ogawa et al.	5,801,104	A	9/1998	Schuegraf et al.
5,364,667	A	11/1994	Rhieu	5,806,980	A	9/1998	Berrian
D353,452	S	12/1994	Groenhoff	5,813,851	A	9/1998	Nakao
5,374,315	A	12/1994	Deboer et al.	5,819,092	A	10/1998	Ferguson et al.
5,380,367	A	1/1995	Bertone	5,819,434	A	10/1998	Herchen et al.
5,382,311	A	1/1995	Ishikawa et al.	5,827,435	A	10/1998	Seiji
5,388,945	A	2/1995	Garric et al.	5,827,757	A	10/1998	Robinson, Jr. et al.
5,404,082	A	4/1995	Hernandez et al.	5,836,483	A	11/1998	Disel
5,407,449	A	4/1995	Zinger	5,837,058	A	11/1998	Chen et al.
5,413,813	A	5/1995	Cruse et al.	5,837,320	A	11/1998	Hampden-Smith et al.
5,414,221	A	5/1995	Gardner	5,844,683	A	12/1998	Pavloski et al.
5,415,753	A	5/1995	Hurwitt et al.	5,846,332	A	12/1998	Zhao et al.
5,421,893	A	6/1995	Perlov	5,851,294	A	12/1998	Young et al.
5,422,139	A	6/1995	Fischer	5,852,879	A	12/1998	Schumaier
5,423,942	A	6/1995	Robbins et al.	5,853,484	A	12/1998	Jeong
5,430,011	A	7/1995	Tanaka et al.	5,855,680	A	1/1999	Soininen et al.
5,444,217	A	8/1995	Moore	5,855,681	A	1/1999	Maydan et al.
5,453,124	A	9/1995	Moslehi et al.	5,857,777	A	1/1999	Schuh
D363,464	S	* 10/1995	Fukasawa D13/182	5,863,123	A	1/1999	Lee
5,494,494	A	2/1996	Mizuno et al.	5,865,205	A	2/1999	Wilmer
5,496,408	A	3/1996	Motoda et al.	5,873,942	A	2/1999	Park
5,501,740	A	3/1996	Besen et al.	5,877,095	A	3/1999	Tamura et al.
5,503,875	A	4/1996	Imai et al.	5,879,128	A	3/1999	Tietz et al.
5,504,042	A	4/1996	Cho et al.	5,884,640	A	3/1999	Fishkin et al.
5,514,439	A	5/1996	Sibley	D409,894	S	5/1999	McClurg
5,518,549	A	5/1996	Hellwig	D411,516	S	* 6/1999	Imafuku D13/182
5,523,616	A	6/1996	Yasuhide	5,908,672	A	6/1999	Ryu
5,527,111	A	6/1996	Lysen et al.	5,916,365	A	6/1999	Sherman
5,527,417	A	6/1996	Iida et al.	D412,270	S	7/1999	Fredrickson
				5,920,798	A	7/1999	Higuchi et al.
				5,937,323	A	8/1999	Orczyk et al.
				5,947,718	A	9/1999	Weaver
				5,954,375	A	9/1999	Trickle et al.

(56)

References Cited

U.S. PATENT DOCUMENTS

5,961,775	A	10/1999	Fujimura	6,225,020	B1	5/2001	Jung et al.
5,968,275	A	10/1999	Lee et al.	6,235,858	B1	5/2001	Swarup et al.
5,970,621	A	10/1999	Bazydola	6,242,359	B1	6/2001	Misra
5,975,492	A	11/1999	Brenes	6,243,654	B1	6/2001	Johnson et al.
5,979,506	A	11/1999	Aarseth	6,245,665	B1	6/2001	Yokoyama
5,982,931	A	11/1999	Ishimaru	6,247,245	B1	6/2001	Ishii
5,984,391	A	11/1999	Vanderpot et al.	6,250,250	B1	6/2001	Maishev et al.
5,987,480	A	11/1999	Donohue et al.	6,257,758	B1	7/2001	Culbertson
5,997,588	A	12/1999	Goodwin	6,264,467	B1	7/2001	Andreas et al.
5,997,768	A	12/1999	Scully	6,271,148	B1	8/2001	Kao
5,998,870	A	12/1999	Lee et al.	6,274,878	B1	8/2001	Li et al.
6,001,267	A	12/1999	Os et al.	6,281,098	B1	8/2001	Wang
D419,652	S	1/2000	Hall et al.	6,281,141	B1	8/2001	Das et al.
6,013,553	A	1/2000	Wallace	6,284,050	B1	9/2001	Shi et al.
6,013,920	A	1/2000	Gordon et al.	6,287,965	B1	9/2001	Kang et al.
6,015,465	A	1/2000	Kholodenko et al.	6,293,700	B1	9/2001	Lund et al.
6,017,779	A	1/2000	Miyasaka	D449,873	S	10/2001	Bronson
6,017,818	A	1/2000	Lu	6,296,909	B1	10/2001	Spitsberg
6,024,799	A	2/2000	Chen	6,299,133	B2	10/2001	Waragai et al.
6,035,101	A	3/2000	Sajoto et al.	6,302,964	B1	10/2001	Umotoy et al.
6,042,652	A	3/2000	Hyun	6,303,523	B2	10/2001	Cheung
6,044,860	A	4/2000	Nue	6,305,898	B1	10/2001	Yamagishi et al.
6,045,260	A	4/2000	Schwartz et al.	6,311,016	B1	10/2001	Yanagawa et al.
6,048,154	A	4/2000	Wytman	6,312,525	B1	11/2001	Bright et al.
6,050,506	A	4/2000	Guo et al.	6,315,512	B1	11/2001	Tabrizi et al.
6,054,678	A	4/2000	Miyazaki	6,316,162	B1	11/2001	Jung et al.
6,060,691	A	5/2000	Minami et al.	6,321,680	B2	11/2001	Cook et al.
6,060,721	A	5/2000	Huang	D451,893	S	12/2001	Robson
6,068,441	A	5/2000	Raaijmakers et al.	D452,220	S	12/2001	Robson
6,072,163	A	6/2000	Armstrong	6,325,858	B1	12/2001	Wengert
6,073,973	A	6/2000	Boscaljon et al.	6,326,597	B1	12/2001	Lubomirsky et al.
6,074,443	A	6/2000	Venkatesh	6,329,297	B1	12/2001	Balish
6,083,321	A	7/2000	Lei et al.	6,342,427	B1	1/2002	Choi et al.
6,086,677	A	7/2000	Umotoy et al.	6,344,084	B1	2/2002	Koinuma et al.
6,091,062	A	7/2000	Pfahnl et al.	6,344,232	B1	2/2002	Jones et al.
6,093,252	A	7/2000	Wengert et al.	6,347,636	B1	2/2002	Xia
6,093,253	A	7/2000	Lofgren	6,350,391	B1	2/2002	Livshits et al.
6,096,267	A	8/2000	Kishkovich	6,352,945	B1	3/2002	Matsuki
6,099,302	A	8/2000	Hong et al.	D455,024	S	4/2002	Mimick et al.
6,102,565	A	8/2000	Kita et al.	6,367,410	B1	4/2002	Leahey et al.
6,104,011	A	8/2000	Juliano	6,368,773	B1	4/2002	Jung et al.
6,104,401	A	8/2000	Parsons	6,368,987	B1	4/2002	Kopacz et al.
6,106,678	A	8/2000	Shufflebotham	6,370,796	B1	4/2002	Zucker
6,119,710	A	9/2000	Brown	6,372,583	B1	4/2002	Tyagi
6,121,061	A	9/2000	Van Bilsen et al.	6,374,831	B1	4/2002	Chandran
6,121,158	A	9/2000	Benchikha et al.	6,375,312	B1	4/2002	Ikeda et al.
6,122,036	A	9/2000	Yamasaki et al.	6,375,750	B1	4/2002	Van Os et al.
6,124,600	A	9/2000	Moroishi et al.	6,379,466	B1*	4/2002	Sahin C23C 16/455 118/715
6,125,789	A	10/2000	Gupta et al.	D457,609	S	5/2002	Piano
6,126,848	A	10/2000	Li et al.	6,383,566	B1	5/2002	Zagdoun
6,129,044	A	10/2000	Zhao et al.	6,383,955	B1	5/2002	Matsuki
6,129,546	A	10/2000	Sada	6,387,207	B1	5/2002	Janakiraman
6,134,807	A	10/2000	Komino	6,391,803	B1	5/2002	Kim et al.
6,137,240	A	10/2000	Bogdan et al.	6,395,650	B1	5/2002	Callegari et al.
6,140,252	A	10/2000	Cho et al.	6,398,184	B1	6/2002	Sowada et al.
6,148,761	A	11/2000	Majewski et al.	6,410,459	B2	6/2002	Blalock et al.
6,158,941	A	12/2000	Muka et al.	6,413,321	B1	7/2002	Kim et al.
6,160,244	A	12/2000	Ohashi	6,413,583	B1	7/2002	Moghadam et al.
6,161,500	A	12/2000	Kopacz et al.	6,420,279	B1	7/2002	Ono et al.
6,162,323	A	12/2000	Koshimizu et al.	D461,233	S	8/2002	Whalen
6,174,809	B1	1/2001	Kang et al.	D461,882	S	8/2002	Piano
6,178,918	B1	1/2001	Van Os et al.	6,432,849	B1	8/2002	Endo et al.
6,180,979	B1	1/2001	Hofman et al.	6,435,798	B1	8/2002	Satoh
6,187,672	B1	2/2001	Zhao	6,435,865	B1	8/2002	Tseng et al.
6,187,691	B1	2/2001	Fukuda	6,436,819	B1	8/2002	Zhang
6,190,634	B1	2/2001	Lieber et al.	6,437,444	B2	8/2002	Andideh
6,191,399	B1	2/2001	Van Bilsen	6,438,502	B1	8/2002	Awtrey
6,194,037	B1	2/2001	Terasaki et al.	6,441,350	B1	8/2002	Stoddard et al.
6,201,999	B1	3/2001	Jevtic	6,445,574	B1	9/2002	Saw et al.
6,203,613	B1	3/2001	Gates et al.	6,446,573	B2	9/2002	Hirayama et al.
6,207,932	B1	3/2001	Yoo	6,447,232	B1	9/2002	Davis et al.
6,212,789	B1	4/2001	Kato	6,447,651	B1	9/2002	Ishikawa et al.
6,214,122	B1	4/2001	Thompson	6,448,192	B1	9/2002	Kaushik
6,217,658	B1	4/2001	Orczyk et al.	6,450,757	B1	9/2002	Saeki
6,218,288	B1	4/2001	Li et al.	6,451,713	B1	9/2002	Tay et al.
				6,454,860	B2	9/2002	Metzner et al.
				6,455,225	B1	9/2002	Kong et al.
				6,455,445	B2	9/2002	Matsuki

(56)

References Cited

U.S. PATENT DOCUMENTS

6,461,435	B1	10/2002	Littau et al.	6,676,290	B1	1/2004	Lu
6,461,436	B1	10/2002	Campbell et al.	6,682,971	B2	1/2004	Tsuneda et al.
6,468,924	B2	10/2002	Lee	6,682,973	B1	1/2004	Paton et al.
6,471,779	B1	10/2002	Nishio et al.	D486,891	S	2/2004	Cronce
6,472,266	B1	10/2002	Yu et al.	6,684,659	B1	2/2004	Tanaka et al.
6,475,276	B1	11/2002	Elers et al.	6,688,784	B1	2/2004	Templeton
6,475,930	B1	11/2002	Junker et al.	6,689,220	B1	2/2004	Nguyen
6,478,872	B1	11/2002	Chae et al.	6,692,575	B1	2/2004	Omstead et al.
6,482,331	B2	11/2002	Lu et al.	6,692,576	B2	2/2004	Halpin et al.
6,482,663	B1	11/2002	Buckland	6,699,003	B2	3/2004	Saeki
6,483,989	B1	11/2002	Okada et al.	6,699,399	B1	3/2004	Qian et al.
6,494,065	B2	12/2002	Babbitt	6,709,989	B2	3/2004	Ramdani et al.
6,494,998	B1	12/2002	Brcka	6,710,364	B2	3/2004	Guldi et al.
6,496,819	B1	12/2002	Bello et al.	6,710,857	B2	3/2004	Kondo
6,499,533	B2	12/2002	Yamada	6,713,824	B1	3/2004	Mikata
6,503,079	B2	1/2003	Kogano et al.	6,716,571	B2	4/2004	Gabriel
6,503,562	B1	1/2003	Saito et al.	6,720,260	B1	4/2004	Fair et al.
6,503,826	B1	1/2003	Oda	6,722,837	B2	4/2004	Inui
6,506,253	B2	1/2003	Sakuma	6,723,642	B1	4/2004	Lim et al.
6,507,410	B1	1/2003	Robertson et al.	6,730,614	B1	5/2004	Lim et al.
6,511,539	B1	1/2003	Raaijmakers	6,732,006	B2	5/2004	Haanstra et al.
6,514,313	B1	2/2003	Spiegelman	6,734,090	B2	5/2004	Agarwala et al.
6,514,666	B1	2/2003	Choi et al.	6,740,853	B1	5/2004	Kitayama et al.
6,521,295	B1	2/2003	Remington	6,743,475	B2	6/2004	Skarp et al.
6,521,547	B1	2/2003	Chang et al.	6,743,738	B2	6/2004	Todd et al.
6,528,430	B2	3/2003	Kwan	6,745,095	B1	6/2004	Ben-Dov
6,528,767	B2	3/2003	Bagley et al.	6,753,507	B2	6/2004	Fure et al.
6,531,193	B2	3/2003	Fonash et al.	6,755,221	B2	6/2004	Jeong et al.
6,531,412	B2	3/2003	Conti et al.	6,756,085	B2	6/2004	Waldfried
6,534,133	B1	3/2003	Kaloyeros et al.	6,756,293	B2	6/2004	Li et al.
6,534,395	B2	3/2003	Werkhoven et al.	6,756,318	B2	6/2004	Nguyen et al.
6,536,950	B1	3/2003	Green	6,759,098	B2	7/2004	Han
6,540,469	B2	4/2003	Matsunaga et al.	6,760,981	B2	7/2004	Leap
6,544,906	B2	4/2003	Rotondaro et al.	6,784,108	B1	8/2004	Donohoe et al.
6,552,209	B1	4/2003	Lei et al.	D497,977	S	11/2004	Engelbrektsson
6,558,755	B2	5/2003	Berry et al.	6,811,960	B2	11/2004	Lee et al.
6,559,026	B1	5/2003	Rossman et al.	6,815,350	B2	11/2004	Kim et al.
6,566,278	B1	5/2003	Harvey et al.	6,820,570	B2	11/2004	Kilpela et al.
6,569,239	B2	5/2003	Arai et al.	6,821,910	B2	11/2004	Adomaitis et al.
6,569,971	B2	5/2003	Roh et al.	6,824,665	B2	11/2004	Shelnut et al.
6,573,030	B1	6/2003	Fairbairn et al.	6,825,134	B2	11/2004	Law et al.
6,574,644	B2	6/2003	Hsu et al.	6,828,235	B2	12/2004	Takano
6,576,062	B2	6/2003	Matsuse	6,831,004	B2	12/2004	Byun
6,576,064	B2	6/2003	Griffiths et al.	6,835,039	B2	12/2004	Van Den Berg
6,576,300	B1	6/2003	Berry et al.	6,846,146	B2	1/2005	Inui
6,576,564	B2	6/2003	Agarwal	6,846,515	B2	1/2005	Vrtis
6,578,589	B1	6/2003	Mayusumi	6,846,742	B2	1/2005	Rossman
6,579,833	B1	6/2003	McNallan et al.	6,847,014	B1	1/2005	Benjamin et al.
6,580,050	B1	6/2003	Miller et al.	6,858,524	B2	2/2005	Haukka et al.
6,583,048	B1	6/2003	Vincent et al.	6,858,547	B2	2/2005	Metzner
6,589,707	B2	7/2003	Lee et al.	6,863,019	B2	3/2005	Shamouilian
6,589,868	B2	7/2003	Rossman	6,863,281	B2	3/2005	Endou et al.
6,590,251	B2	7/2003	Kang et al.	6,864,041	B2	3/2005	Brown
6,594,550	B1	7/2003	Okrah	6,872,258	B2	3/2005	Park et al.
6,596,653	B2	7/2003	Tan	6,872,259	B2	3/2005	Strang
6,598,559	B1	7/2003	Vellore et al.	6,874,247	B1	4/2005	Hsu
6,607,868	B2	8/2003	Choi	6,874,480	B1	4/2005	Ismailov
6,607,948	B1	8/2003	Sugiyama et al.	6,875,677	B1	4/2005	Conley, Jr. et al.
6,608,745	B2	8/2003	Tsuruta et al.	6,876,017	B2	4/2005	Goodner
6,620,251	B2	9/2003	Kitano	6,878,402	B2	4/2005	Chiang et al.
6,624,064	B1	9/2003	Sahin	6,884,066	B2	4/2005	Nguyen et al.
6,627,268	B1	9/2003	Fair et al.	6,884,295	B2	4/2005	Ishii
6,627,503	B2	9/2003	Ma et al.	6,884,319	B2	4/2005	Kim
6,632,478	B2	10/2003	Gaillard et al.	D505,590	S	5/2005	Greiner
6,633,364	B2	10/2003	Hayashi	6,889,211	B1	5/2005	Yoshiura et al.
6,635,117	B1	10/2003	Kinnard et al.	6,889,864	B2	5/2005	Lindfors et al.
6,638,839	B2	10/2003	Deng et al.	6,895,158	B2	5/2005	Alyward et al.
6,645,304	B2	11/2003	Yamaguchi	6,899,507	B2	5/2005	Yamagishi et al.
6,648,974	B1	11/2003	Ogliari et al.	6,909,839	B2	6/2005	Wang et al.
6,649,921	B1	11/2003	Cekic et al.	6,911,092	B2	6/2005	Sneh
6,652,924	B2	11/2003	Sherman	6,913,152	B2	7/2005	Zuk
6,656,281	B1	12/2003	Ueda	6,913,796	B2	7/2005	Albano et al.
6,660,662	B2	12/2003	Ishikawa et al.	6,917,755	B2	7/2005	Nguyen et al.
6,662,817	B2	12/2003	Yamagishi	6,924,078	B2	8/2005	Lee et al.
6,673,196	B1	1/2004	Oyabu	6,929,700	B2	8/2005	Tan et al.
				6,930,041	B2	8/2005	Agarwal
				6,930,059	B2	8/2005	Conley, Jr. et al.
				6,935,269	B2	8/2005	Lee et al.
				6,939,817	B2	9/2005	Sandhu et al.

(56)

References Cited

U.S. PATENT DOCUMENTS

6,942,753	B2	9/2005	Choi et al.	7,208,413	B2	6/2007	Byun et al.
6,951,587	B1	10/2005	Narushima	7,234,476	B2	6/2007	Arai
6,953,609	B2	10/2005	Carollo	7,235,137	B2	6/2007	Kitayama et al.
6,955,836	B2	10/2005	Kumagai et al.	7,235,482	B2	6/2007	Wu
6,972,055	B2	12/2005	Sferlazzo	7,235,501	B2	6/2007	Ahn et al.
6,972,478	B1	12/2005	Waite et al.	7,238,596	B2	7/2007	Kouvetakis et al.
6,974,781	B2	12/2005	Timmermans et al.	7,238,616	B2	7/2007	Agarwal
6,975,921	B2	12/2005	Verhaar	7,238,653	B2	7/2007	Lee et al.
6,976,822	B2	12/2005	Woodruff	7,265,061	B1	9/2007	Cho et al.
6,981,832	B2	1/2006	Zinger et al.	7,274,867	B2	9/2007	Peukert
6,982,046	B2	1/2006	Srivastava et al.	D553,104	S	10/2007	Oohashi et al.
6,984,595	B1	1/2006	Yamazaki	7,279,256	B2	10/2007	Son
6,985,788	B2	1/2006	Haanstra et al.	7,290,813	B2	11/2007	Bonora
6,987,155	B2	1/2006	Roh et al.	7,294,581	B2	11/2007	Haverkort et al.
6,990,430	B2	1/2006	Hosek	7,296,460	B2	11/2007	Dimeo et al.
7,005,227	B2	2/2006	Yueh et al.	7,297,641	B2	11/2007	Todd et al.
7,005,391	B2	2/2006	Min	7,298,009	B2	11/2007	Yan et al.
7,010,580	B1	3/2006	Fu et al.	D557,226	S	12/2007	Uchino et al.
7,017,514	B1	3/2006	Shepherd et al.	7,307,028	B2	12/2007	Goto et al.
7,018,941	B2	3/2006	Cui et al.	7,307,178	B2	12/2007	Kiyomori et al.
7,021,881	B2	4/2006	Yamagishi	7,312,148	B2	12/2007	Ramaswamy et al.
7,036,453	B2	5/2006	Ishikawa et al.	7,312,162	B2	12/2007	Ramaswamy et al.
7,041,609	B2	5/2006	Vaartstra	7,312,494	B2	12/2007	Ahn et al.
7,045,430	B2	5/2006	Ahn et al.	7,320,544	B2	1/2008	Hsieh
7,049,247	B2	5/2006	Gates et al.	7,323,401	B2	1/2008	Ramaswamy et al.
7,053,009	B2	5/2006	Conley, Jr. et al.	7,326,657	B2	2/2008	Xia et al.
7,055,875	B2	6/2006	Bonora	7,327,948	B1	2/2008	Shrinivasan
7,062,161	B2	6/2006	Kusuda et al.	7,329,947	B2	2/2008	Adachi et al.
7,070,178	B2	7/2006	Van Der Toorn et al.	7,335,611	B2	2/2008	Ramaswamy et al.
7,071,051	B1	7/2006	Jeon et al.	7,351,057	B2	4/2008	Berenbak et al.
7,073,834	B2	7/2006	Matsumoto et al.	7,354,847	B2	4/2008	Chan et al.
7,080,545	B2	7/2006	Dimeo et al.	7,354,873	B2	4/2008	Fukazawa et al.
7,084,060	B1	8/2006	Furukawa	7,356,762	B2	4/2008	van Driel
7,084,079	B2	8/2006	Conti et al.	7,357,138	B2	4/2008	Ji et al.
7,085,623	B2	8/2006	Siegers	7,361,447	B2	4/2008	Jung
7,088,003	B2	8/2006	Gates et al.	7,376,520	B2	5/2008	Wong
7,090,394	B2	8/2006	Hashikura et al.	7,379,785	B2	5/2008	Higashi et al.
7,092,287	B2	8/2006	Beulens et al.	7,381,644	B1	6/2008	Soubramonium et al.
7,098,149	B2	8/2006	Lukas	7,387,685	B2	6/2008	Choi et al.
7,101,763	B1	9/2006	Anderson et al.	7,393,207	B2	7/2008	Imai
7,109,098	B1	9/2006	Ramaswamy et al.	7,393,418	B2	7/2008	Yokogawa
7,109,114	B2	9/2006	Chen et al.	7,393,736	B2	7/2008	Ahn et al.
7,111,232	B1	9/2006	Bascom	7,393,765	B2	7/2008	Hanawa et al.
7,115,305	B2	10/2006	Bronikowski et al.	7,396,491	B2	7/2008	Marking et al.
7,115,838	B2	10/2006	Kurara et al.	7,399,388	B2	7/2008	Moghadam et al.
7,122,085	B2	10/2006	Shero et al.	7,399,570	B2	7/2008	Lee et al.
7,122,222	B2	10/2006	Xiao et al.	7,402,534	B2	7/2008	Mahajani
7,129,165	B2	10/2006	Basol et al.	7,405,166	B2	7/2008	Liang et al.
7,132,360	B2	11/2006	Schaeffer et al.	7,405,454	B2	7/2008	Ahn et al.
7,135,421	B2	11/2006	Ahn et al.	D575,713	S	8/2008	Ratcliffe
7,143,897	B1	12/2006	Guzman et al.	7,410,290	B2	8/2008	Tanaka
7,147,766	B2	12/2006	Uzoh et al.	7,410,666	B2	8/2008	Elers
7,153,542	B2	12/2006	Nguyen et al.	7,411,352	B2	8/2008	Madocks
7,156,380	B2	1/2007	Soininen	7,414,281	B1	8/2008	Fastow
7,163,393	B2	1/2007	Adachi et al.	D576,001	S	9/2008	Brunderman
7,163,721	B2	1/2007	Zhang et al.	7,422,635	B2	9/2008	Zheng et al.
7,163,900	B2	1/2007	Weber	7,422,653	B2	9/2008	Blahnik et al.
7,168,852	B2	1/2007	Linnarsson	7,422,775	B2	9/2008	Ramaswamy et al.
7,172,497	B2	2/2007	Basol et al.	7,429,532	B2	9/2008	Ramaswamy et al.
7,186,648	B1	3/2007	Rozbicki	7,431,966	B2	10/2008	Derderian et al.
7,192,824	B2	3/2007	Ahn et al.	7,432,476	B2	10/2008	Morita et al.
7,192,892	B2	3/2007	Ahn et al.	7,437,060	B2	10/2008	Wang et al.
7,195,693	B2	3/2007	Cowans	7,442,275	B2	10/2008	Cowans
7,198,447	B2	4/2007	Morimitsu et al.	7,467,632	B2	12/2008	Lee et al.
7,201,943	B2	4/2007	Park et al.	7,475,588	B2	1/2009	Dimeo et al.
7,204,887	B2	4/2007	Kawamura et al.	7,476,291	B2	1/2009	Wang et al.
7,205,246	B2	4/2007	MacNeil et al.	7,479,198	B2	1/2009	Gulfrey
7,205,247	B2	4/2007	Lee et al.	7,482,247	B1	1/2009	Papasouliotis
7,207,763	B2	4/2007	Lee	7,482,283	B2	1/2009	Yamasaki et al.
7,208,389	B1	4/2007	Tipton et al.	D585,968	S	2/2009	Elkins et al.
7,210,925	B2	5/2007	Adachi	7,489,389	B2	2/2009	Shibazaki et al.
7,211,524	B2	5/2007	Ryu et al.	7,494,882	B2	2/2009	Vitale
7,211,525	B1	5/2007	Shanker	7,497,614	B2	3/2009	Gaff
7,214,630	B1	5/2007	Varadarajan et al.	7,498,242	B2	3/2009	Kumar et al.
7,223,014	B2	5/2007	Lojen	7,501,292	B2	3/2009	Matsushita et al.
				7,501,355	B2	3/2009	Bhatia et al.
				7,503,980	B2	3/2009	Kida et al.
				D590,933	S	4/2009	Vansell
				7,514,375	B1	4/2009	Shanker et al.

(56)

References Cited

U.S. PATENT DOCUMENTS

7,541,297 B2	4/2009	Mallick et al.	7,771,796 B2	8/2010	Kohno et al.
D593,969 S	6/2009	Li	7,780,440 B2	8/2010	Shibagaki et al.
7,547,363 B2	6/2009	Tomiyasu et al.	7,781,352 B2	8/2010	Fukazawa et al.
7,547,633 B2	6/2009	Ravish et al.	7,789,559 B2	9/2010	Waser et al.
7,550,396 B2	6/2009	Frohberg et al.	7,789,965 B2	9/2010	Matsushita et al.
7,561,982 B2	7/2009	Rund et al.	7,790,633 B1	9/2010	Tarafdar et al.
7,563,715 B2	7/2009	Haukka et al.	7,798,096 B2	9/2010	Mahajani et al.
7,566,891 B2	7/2009	Rocha-Alvarez et al.	7,803,722 B2	9/2010	Liang
7,575,968 B2	8/2009	Sadaka et al.	7,806,587 B2	10/2010	Kobayashi
7,579,285 B2	8/2009	Zimmerman et al.	7,807,566 B2	10/2010	Tsuji et al.
7,579,785 B2	8/2009	DeVincentis et al.	7,807,578 B2	10/2010	Bencher et al.
D600,223 S	9/2009	Aggarwal	7,816,278 B2	10/2010	Reed et al.
7,582,555 B1	9/2009	Lang	7,824,492 B2	11/2010	Tois et al.
7,582,575 B2	9/2009	Fukazawa et al.	7,825,040 B1	11/2010	Fukazawa et al.
7,589,003 B2	9/2009	Kouvetakis et al.	7,829,460 B2	11/2010	Streck et al.
7,589,029 B2	9/2009	Derderian et al.	7,833,353 B2	11/2010	Furukawahara et al.
7,591,601 B2	9/2009	Matsuoka et al.	7,838,084 B2	11/2010	Derderian et al.
D602,575 S	10/2009	Breda	7,842,518 B2	11/2010	Miyajima
7,598,513 B2	10/2009	Kouvetakis et al.	7,842,622 B1	11/2010	Lee et al.
7,601,223 B2	10/2009	Lindfors et al.	D629,874 S	12/2010	Hermans
7,601,225 B2	10/2009	Tuominen et al.	7,850,449 B2	12/2010	Yang et al.
7,601,652 B2	10/2009	Singh et al.	7,851,019 B2	12/2010	Tuominen et al.
7,611,751 B2	11/2009	Elers	7,851,232 B2	12/2010	van Schravendijk et al.
7,611,980 B2	11/2009	Wells et al.	7,858,519 B2	12/2010	Liu et al.
7,618,226 B2	11/2009	Takizawa	7,858,533 B2	12/2010	Liu et al.
7,621,672 B2	11/2009	Ripley	7,865,070 B2	1/2011	Nakamura
7,622,369 B1	11/2009	Lee et al.	7,871,198 B2	1/2011	Rempe et al.
7,622,378 B2	11/2009	Liu et al.	7,874,726 B2	1/2011	Jacobs et al.
7,623,940 B2	11/2009	Huskamp et al.	7,884,918 B2	2/2011	Hattori
D606,952 S	12/2009	Lee	7,888,233 B1	2/2011	Gauri
7,625,820 B1	12/2009	Papasouliotis	D634,329 S	3/2011	Wastrom
7,629,277 B2	12/2009	Ghatnagar	D634,719 S	3/2011	Yasuda et al.
7,632,549 B2	12/2009	Goundar	7,897,215 B1	3/2011	Fair et al.
7,640,142 B2	12/2009	Tachikawa et al.	7,897,217 B2	3/2011	Faguet
7,645,341 B2	1/2010	Kennedy et al.	7,902,582 B2	3/2011	Forbes et al.
7,645,484 B2	1/2010	Ishizaka	7,906,174 B1	3/2011	Wu et al.
7,648,927 B2	1/2010	Singh et al.	7,910,288 B2	3/2011	Abatchev et al.
7,651,269 B2	1/2010	Comendant	7,915,139 B1	3/2011	Lang
7,651,583 B2	1/2010	Kent et al.	7,915,667 B2	3/2011	Knoeffler et al.
7,651,955 B2	1/2010	Ravish et al.	7,919,416 B2	4/2011	Lee et al.
7,651,959 B2	1/2010	Fukazawa et al.	7,925,378 B2	4/2011	Gilchrist et al.
7,651,961 B2	1/2010	Clark	7,935,940 B1	5/2011	Smargiassi
D609,652 S	2/2010	Nagasaka	7,939,447 B2	5/2011	Bauer et al.
D609,655 S	2/2010	Sugimoto	7,942,969 B2	5/2011	Riker et al.
7,661,299 B2	2/2010	Kusunoki	7,946,762 B2	5/2011	Yednak
7,678,197 B2	3/2010	Maki	7,951,262 B2	5/2011	Koshiishi et al.
7,678,715 B2	3/2010	Mungekar et al.	7,955,516 B2	6/2011	Chandrachood
7,682,454 B2	3/2010	Sneh	7,955,650 B2	6/2011	Tsuji
7,682,657 B2	3/2010	Sherman	7,957,708 B2	6/2011	Karschnia et al.
D613,829 S	4/2010	Griffin et al.	7,963,736 B2	6/2011	Takizawa et al.
D614,153 S	4/2010	Fondurulia et al.	7,967,913 B2	6/2011	Hua et al.
D614,267 S	4/2010	Breda	7,972,980 B2	7/2011	Lee et al.
D614,268 S	4/2010	Breda	7,977,256 B2	7/2011	Liu et al.
D614,593 S	4/2010	Lee	7,981,751 B2	7/2011	Zhu et al.
7,690,881 B2	4/2010	Yamagishi	D643,055 S	8/2011	Takahashi
7,691,205 B2	4/2010	Ikedo	7,989,736 B2	8/2011	Park et al.
7,692,171 B2	4/2010	Kaszuba et al.	7,992,318 B2	8/2011	Kawaji
7,695,808 B2	4/2010	Tuma	7,994,721 B2	8/2011	Espiau et al.
7,713,874 B2	5/2010	Milligan	7,997,795 B2	8/2011	Schwagerman et al.
7,716,993 B2	5/2010	Ozawa et al.	7,998,875 B2	8/2011	DeYoung
7,720,560 B2	5/2010	Menser et al.	8,003,174 B2	8/2011	Fukazawa
7,723,648 B2	5/2010	Tsukamoto et al.	8,003,919 B2	8/2011	Goto et al.
7,727,864 B2	6/2010	Elers	8,004,198 B2	8/2011	Bakre et al.
7,732,343 B2	6/2010	Niroomand et al.	8,020,315 B2	9/2011	Nishimura
7,736,437 B2	6/2010	Cadwell et al.	8,030,129 B2	10/2011	Jeong
7,736,528 B2	6/2010	Okita et al.	8,033,771 B1	10/2011	Gage et al.
7,740,437 B2	6/2010	de Ridder et al.	8,038,835 B2	10/2011	Hayashi et al.
7,740,705 B2	6/2010	Li	8,041,197 B2	10/2011	Kasai et al.
7,745,346 B2	6/2010	Hausmann et al.	8,041,450 B2	10/2011	Takizawa et al.
7,748,760 B2	7/2010	Kushida	8,043,972 B1	10/2011	Liu et al.
7,749,563 B2	7/2010	Zheng et al.	8,046,193 B2	10/2011	Yetter et al.
7,753,584 B2	7/2010	Gambino et al.	8,048,783 B2	11/2011	Chung et al.
7,754,621 B2	7/2010	Putjkonen	8,055,378 B2	11/2011	Numakura
7,763,869 B2	7/2010	Matsushita et al.	8,060,252 B2	11/2011	Gage et al.
7,767,262 B2	8/2010	Clark	8,083,853 B2	11/2011	Choi et al.
			D651,291 S	12/2011	Liebson et al.
			8,071,451 B2	12/2011	Uzoh
			8,071,452 B2	12/2011	Raisanen
			8,072,578 B2	12/2011	Yasuda et al.

(56)	References Cited								
	U.S. PATENT DOCUMENTS								
	8,076,230 B2	12/2011	Wei		8,404,499 B2	3/2013	Moffatt		
	8,076,237 B2	12/2011	Uzoh		8,415,258 B2	4/2013	Akae		
	8,076,250 B1	12/2011	Rajagopalan		8,415,259 B2	4/2013	Lee et al.		
	8,076,251 B2	12/2011	Akae et al.		8,419,959 B2*	4/2013	Bettencourt	H01J 37/3244
	8,078,310 B2	12/2011	Nishimoto et al.						156/345.34
	8,082,946 B2	12/2011	Laverdiere et al.		8,440,259 B2	5/2013	Chiang et al.		
	8,084,104 B2	12/2011	Shinriki et al.		8,444,120 B2	5/2013	Gregg et al.		
	8,084,372 B2	12/2011	You et al.		8,445,075 B2	5/2013	Xu et al.		
	D652,896 S	1/2012	Gether		8,450,191 B2	5/2013	Wang		
	8,092,604 B2	1/2012	Tomiyasu et al.		8,465,811 B2	6/2013	Ueda		
	8,100,583 B2	1/2012	Aggarwal		8,466,411 B2	6/2013	Arai		
	D653,734 S	2/2012	Sisk		8,470,187 B2	6/2013	Ha		
	D654,882 S *	2/2012	Honma	8,484,846 B2	7/2013	Dhindsa		
	D654,884 S	2/2012	Honma	D13/182	8,492,170 B2	7/2013	Xie et al.		
	D655,055 S	2/2012	Toll		8,496,377 B2	7/2013	Harr et al.		
	8,110,099 B2	2/2012	Hersey et al.		8,496,756 B2	7/2013	Cruse et al.		
	8,114,734 B2	2/2012	Yang et al.		8,497,213 B2	7/2013	Yasui et al.		
	8,119,466 B2	2/2012	Avouris		8,501,599 B2	8/2013	Ueno et al.		
	D655,260 S *	3/2012	Honma	8,506,162 B2	8/2013	Schick et al.		
	D655,261 S *	3/2012	Honma	8,506,713 B2	8/2013	Takagi		
	8,129,290 B2	3/2012	Balseanu et al.		8,529,701 B2	9/2013	Morita		
	8,137,462 B2	3/2012	Fondurulia et al.		8,535,767 B1	9/2013	Kimura		
	8,137,465 B1	3/2012	Shrinivasan et al.		D691,974 S	10/2013	Osada et al.		
	8,138,104 B2	3/2012	Balseanu et al.		8,551,892 B2	10/2013	Nakano		
	8,138,676 B2	3/2012	Mills		8,562,272 B2	10/2013	Lenz		
	8,142,862 B2	3/2012	Lee et al.		8,563,443 B2	10/2013	Fukazawa		
	8,143,174 B2	3/2012	Xia et al.		8,569,184 B2	10/2013	Oka		
	8,147,242 B2	4/2012	Shibagaki et al.		8,573,152 B2*	11/2013	de la Llera	H01R 13/20
	8,158,512 B2	4/2012	Ji et al.						118/723 E
	8,172,947 B2	5/2012	Shibata et al.		8,586,484 B2	11/2013	Matsuyama et al.		
	8,173,554 B2	5/2012	Lee et al.		8,591,659 B1	11/2013	Fang et al.		
	8,178,436 B2	5/2012	King et al.		8,592,005 B2	11/2013	Ueda		
	8,187,679 B2	5/2012	Dickey et al.		8,608,885 B2	11/2013	Goto et al.		
	8,187,951 B1	5/2012	Wang		D694,790 S *	12/2013	Matsumoto	D15/138
	8,272,516 B2	5/2012	Salvador		D695,240 S	12/2013	Iida et al.		
	8,192,901 B2	6/2012	Kageyama		8,614,047 B2	12/2013	Ayothi et al.		
	8,196,234 B2	6/2012	Glunk		8,616,765 B2	12/2013	Darabnia et al.		
	8,197,915 B2	6/2012	Oka et al.		8,617,411 B2	12/2013	Singh		
	8,198,168 B2	6/2012	Tanioku		D697,038 S *	1/2014	Matsumoto	D13/182
	8,206,506 B2*	6/2012	Kadkhodayan	8,633,115 B2	1/2014	Chang et al.		
				H01J 7/32449	D698,904 S	2/2014	Milligan et al.		
				118/715	8,642,488 B2	2/2014	Liu et al.		
	8,216,380 B2	7/2012	White et al.		8,647,722 B2	2/2014	Kobayashi et al.		
	8,231,799 B2	7/2012	Bera et al.		8,664,627 B1	3/2014	Ishikawa et al.		
	D665,055 S	8/2012	Yanagisawa et al.		8,667,654 B2	3/2014	Gros-Jean		
	8,241,991 B2	8/2012	Hsieh et al.		8,668,957 B2	3/2014	Dussarrat et al.		
	8,242,028 B1	8/2012	van Schravendijk et al.		8,669,185 B2	3/2014	Onizawa		
	8,242,031 B2	8/2012	Mallick et al.		8,679,958 B2	3/2014	Takamura et al.		
	8,246,900 B2	8/2012	Kasai et al.		D702,188 S	4/2014	Jacobs		
	8,252,114 B2	8/2012	Vukovic		8,683,943 B2	4/2014	Onodera et al.		
	8,252,659 B2	8/2012	Huyghabaert et al.		8,710,580 B2	4/2014	Sakuma et al.		
	8,252,691 B2	8/2012	Beynet et al.		8,711,338 B2	4/2014	Liu et al.		
	8,267,633 B2	9/2012	Obikane		D705,745 S	5/2014	Kurs et al.		
	8,278,176 B2	10/2012	Bauer et al.		D705,762 S	5/2014	Yu		
	8,282,769 B2	10/2012	Iizuka		8,664,127 B2	5/2014	Bhatia et al.		
	8,282,847 B2	10/2012	Romano		8,720,965 B2	5/2014	Hino et al.		
	8,287,648 B2	10/2012	Reed et al.		8,721,791 B2	5/2014	Choi et al.		
	8,293,016 B2	10/2012	Bahng et al.		8,722,510 B2	5/2014	Watanabe et al.		
	8,293,642 B2	10/2012	Kim		8,722,546 B2	5/2014	Fukazawa et al.		
	8,298,951 B1	10/2012	Nakano		8,726,837 B2	5/2014	Patalay et al.		
	8,307,472 B1	11/2012	Saxon et al.		8,728,832 B2	5/2014	Raisanen et al.		
	8,309,173 B2	11/2012	Tuominen et al.		8,742,668 B2	6/2014	Nakano et al.		
	8,323,413 B2	12/2012	Son		8,759,223 B2	6/2014	Sapre et al.		
	8,328,939 B2	12/2012	Choi et al.		8,764,085 B2	7/2014	Urabe		
	8,329,599 B2	12/2012	Fukazawa et al.		8,771,807 B2	7/2014	Xiao et al.		
	8,334,219 B2	12/2012	Lee et al.		8,779,502 B2	7/2014	Sakuma et al.		
	8,349,083 B2	1/2013	Takasuka et al.		8,784,950 B2	7/2014	Fukazawa et al.		
	D676,943 S	2/2013	Kluss		8,784,951 B2	7/2014	Fukazawa et al.		
	8,367,528 B2	2/2013	Bauer et al.		8,785,215 B2	7/2014	Kobayashi et al.		
	8,372,204 B2	2/2013	Nakamura		8,785,311 B2	7/2014	Miyoshi		
	8,378,464 B2	2/2013	Kato et al.		8,790,743 B1	7/2014	Omari		
	8,393,091 B2	3/2013	Kawamoto		8,790,749 B2	7/2014	Omori et al.		
	8,394,466 B2	3/2013	Hong et al.		8,802,201 B2	8/2014	Raisanen et al.		
	8,398,773 B2	3/2013	Jdira et al.		8,820,809 B2	9/2014	Ando et al.		
	8,402,918 B2*	3/2013	Kadkhodayan	8,821,640 B2	9/2014	Cleary et al.		
				H01J 37/3255	8,841,182 B1	9/2014	Chen et al.		
				118/723 E	8,845,806 B2	9/2014	Aida et al.		
					8,846,502 B2	9/2014	Haukka et al.		
					D715,410 S	10/2014	Lohmann		

(56)

References Cited

U.S. PATENT DOCUMENTS

8,864,202	B1	10/2014	Schrameyer	9,174,178	B2	11/2015	Yudovsky et al.
D716,742	S	11/2014	Jang et al.	9,175,394	B2	11/2015	Berger et al.
8,877,655	B2	11/2014	Shero et al.	9,177,784	B2	11/2015	Raisanen et al.
8,882,923	B2	11/2014	Saido et al.	9,184,047	B2	11/2015	Liu et al.
8,883,270	B2	11/2014	Shero et al.	9,190,263	B2	11/2015	Ishikawa et al.
8,901,016	B2	12/2014	Ha et al.	9,190,264	B2	11/2015	Yuasa et al.
8,911,553	B2	12/2014	Baluja et al.	9,196,483	B1	11/2015	Lee et al.
8,911,826	B2	12/2014	Adachi et al.	D745,641	S *	12/2015	Blum D23/213
8,912,101	B2	12/2014	Tsuji et al.	9,202,727	B2	12/2015	Dunn et al.
D720,838	S	1/2015	Yamagishi et al.	9,214,333	B1	12/2015	Sims et al.
8,927,906	B2	1/2015	Tadokoro et al.	9,228,259	B2	1/2016	Haukka et al.
8,933,375	B2	1/2015	Dunn et al.	9,240,412	B2	1/2016	Xie et al.
8,940,646	B1	1/2015	Chandrasekharan	9,245,742	B2	1/2016	Haukka
D723,153	S	2/2015	Borkholder	9,252,024	B2	2/2016	Lam et al.
8,945,305	B2	2/2015	Marsh	9,257,274	B2	2/2016	Kang et al.
8,945,306	B2	2/2015	Tsuda	9,263,298	B2	2/2016	Matsumoto et al.
8,945,339	B2	2/2015	Kakimoto	9,267,850	B2	2/2016	Aggarwal
8,946,830	B2	2/2015	Jung et al.	D751,176	S *	3/2016	Schoenherr D23/213
8,956,971	B2	2/2015	Huakka	9,281,277	B2	3/2016	Baek et al.
8,956,983	B2	2/2015	Swaminathan	9,284,642	B2	3/2016	Nakano
D723,330	S	3/2015	York	9,297,705	B2	3/2016	Aggarwal
D724,553	S	3/2015	Choi	9,299,557	B2	3/2016	Tolle et al.
D724,701	S	3/2015	Yamagishi et al.	9,299,595	B2	3/2016	Dunn et al.
D725,168	S	3/2015	Yamagishi	D753,269	S	4/2016	Yamagishi et al.
8,967,608	B2	3/2015	Mitsumori et al.	D753,629	S	4/2016	Plattard
8,974,868	B2	3/2015	Ishikawa et al.	9,305,836	B1	4/2016	Gates et al.
8,986,456	B2	3/2015	Fondurulia et al.	9,312,155	B2	4/2016	Mori
8,991,214	B2	3/2015	Hoshino et al.	9,315,897	B2	4/2016	Byun
8,991,887	B2	3/2015	Shin et al.	9,324,811	B2	4/2016	Weeks
8,993,054	B2	3/2015	Jung et al.	9,324,846	B1	4/2016	Camillo
8,993,457	B1	3/2015	Ramkumar et al.	9,337,054	B2	5/2016	Hunks et al.
D726,365	S	4/2015	Weigensberg	9,341,296	B2	5/2016	Yednak
D726,884	S	4/2015	Yamagishi et al.	9,343,297	B1	5/2016	Fukazawa et al.
8,999,102	B2	4/2015	Miyoshi et al.	9,343,308	B2	5/2016	Isii
9,005,539	B2	4/2015	Halpin et al.	9,343,343	B2	5/2016	Mori
9,017,481	B1	4/2015	Pettinger et al.	9,343,350	B2	5/2016	Arai
9,017,933	B2	4/2015	Liu et al.	9,349,620	B2	5/2016	Kamata et al.
9,018,093	B2	4/2015	Tsuji et al.	9,353,441	B2	5/2016	Chung
9,018,111	B2	4/2015	Milligan et al.	9,355,876	B2	5/2016	Rejuter et al.
9,018,567	B2	4/2015	de Ridder et al.	9,365,924	B2	6/2016	Nonaka
9,021,985	B2	5/2015	Alokozai et al.	9,368,352	B2	6/2016	Takamure et al.
9,023,737	B2	5/2015	Beynet et al.	9,370,863	B2	6/2016	Tsuji et al.
9,023,738	B2	5/2015	Kato et al.	9,384,987	B2	7/2016	Jung et al.
9,029,253	B2	5/2015	Milligan et al.	9,390,909	B2	7/2016	Pasquale et al.
9,029,272	B1	5/2015	Nakano	9,394,608	B2	7/2016	Shero et al.
D732,145	S	6/2015	Yamagishi	9,396,934	B2	7/2016	Tolle
D732,644	S	6/2015	Yamagishi et al.	9,396,956	B1	7/2016	Fukazawa
D733,257	S *	6/2015	Schoenherr D23/213	9,404,587	B2	8/2016	Shugrue
D733,261	S	6/2015	Yamagishi et al.	9,412,564	B2	8/2016	Milligan
D733,262	S	7/2015	Yamagishi et al.	9,412,582	B2	8/2016	Sasaki et al.
D733,843	S	7/2015	Yamagishi	9,425,078	B2	8/2016	Tang et al.
D734,377	S	7/2015	Hirakida	9,443,725	B2	9/2016	Liu et al.
D735,836	S	8/2015	Yamagishi	9,447,498	B2	9/2016	Shiba et al.
D736,348	S *	8/2015	Tan D23/213	9,449,793	B2	9/2016	Shaji et al.
9,096,931	B2	8/2015	Yednak et al.	9,455,138	B1	9/2016	Fukazawa
9,099,505	B2	8/2015	Kusakabe et al.	9,464,352	B2	10/2016	Nakano et al.
9,111,972	B2	8/2015	Takeshita et al.	9,478,414	B2	10/2016	Kobayashi et al.
9,117,657	B2	8/2015	Nakano et al.	9,478,415	B2	10/2016	Kimura
9,117,866	B2	8/2015	Marquardt et al.	D770,993	S	11/2016	Yoshida et al.
D739,222	S	9/2015	Chadbourne	9,484,191	B2	11/2016	Winkler
9,123,510	B2	9/2015	Nakano et al.	9,514,927	B2	12/2016	Tolle et al.
9,123,577	B2	9/2015	Fujimoto et al.	9,514,932	B2	12/2016	Mallick et al.
9,129,897	B2	9/2015	Pore et al.	9,543,180	B2	1/2017	Kamiya
9,136,108	B2	9/2015	Matsushita et al.	9,556,516	B2	1/2017	Takamure
9,136,180	B2	9/2015	Machkaoutsan	9,558,931	B2	1/2017	Tang
9,142,393	B2	9/2015	Okabe et al.	9,564,314	B2	2/2017	Takamure et al.
9,142,437	B2	9/2015	Fosnight et al.	9,574,268	B1	2/2017	Dunn et al.
9,153,441	B2	10/2015	Takamure et al.	9,589,770	B2	3/2017	Winkler
9,166,012	B2	10/2015	Sim et al.	9,605,342	B2	3/2017	Alokozai et al.
9,169,975	B2	10/2015	Sarin et al.	9,605,343	B2	3/2017	Winkler
9,171,714	B2	10/2015	Mori	9,607,837	B1	3/2017	Namba
9,171,716	B2	10/2015	Fukuda	D783,351	S	4/2017	Fujino et al.
D742,202	S	11/2015	Cyphers et al.	9,613,801	B2	4/2017	Carcasi et al.
D743,357	S	11/2015	Vyne	9,627,221	B1	4/2017	Zaitso et al.
D743,513	S	11/2015	Yamagishi	D785,766	S	5/2017	Sato
				D787,458	S	5/2017	Kim et al.
				9,640,416	B2	5/2017	Arai
				9,640,448	B2	5/2017	Ikegawa et al.
				9,647,114	B2	5/2017	Margetis

(56)	References Cited		2001/0049202	A1	12/2001	Maeda et al.
	U.S. PATENT DOCUMENTS		2002/0001974	A1	1/2002	Chan
			2002/0001976	A1	1/2002	Danek
			2002/0005400	A1	1/2002	Gat et al.
9,657,845	B2	5/2017	2002/0009119	A1	1/2002	Matthew et al.
9,659,799	B2	5/2017	2002/0011210	A1	1/2002	Satoh et al.
9,663,857	B2	5/2017	2002/0011211	A1	1/2002	Halpin
D789,888	S	6/2017	2002/0013792	A1	1/2002	Imielinski et al.
9,685,320	B2	6/2017	2002/0014204	A1	2/2002	Pyo
9,691,771	B2	6/2017	2002/0014483	A1	2/2002	Suzuki et al.
9,698,031	B2	7/2017	2002/0016829	A1	2/2002	Defosse
9,708,707	B2	7/2017	2002/0023677	A1	2/2002	Zheng
9,708,708	B2	7/2017	2002/0031644	A1	3/2002	Malofsky et al.
9,711,345	B2	7/2017	2002/0041931	A1	4/2002	Suntola et al.
D793,352	S	8/2017	2002/0043337	A1	4/2002	Goodman et al.
D793,572	S	8/2017	2002/0081826	A1	4/2002	Rotondaro et al.
9,735,024	B2	8/2017	2002/0064592	A1	5/2002	Datta et al.
9,741,559	B2	8/2017	2002/0064598	A1	5/2002	Wang et al.
9,748,145	B1	8/2017	2002/0069222	A1	6/2002	McNeely
D796,458	S	9/2017	2002/0076507	A1	6/2002	Chiang et al.
9,754,779	B1	9/2017	2002/0078893	A1	6/2002	Os et al.
9,754,818	B2	9/2017	2002/0079714	A1	6/2002	Soucy et al.
9,759,489	B2	9/2017	2002/0088542	A1	7/2002	Nishikawa et al.
9,790,595	B2	10/2017	2002/0096211	A1	7/2002	Zheng
9,793,115	B2	10/2017	2002/0098627	A1	7/2002	Pomarede et al.
9,793,135	B1	10/2017	2002/0108670	A1	8/2002	Baker et al.
9,793,148	B2	10/2017	2002/0109115	A1	8/2002	Cederstav et al.
D802,546	S	11/2017	2002/0110695	A1	8/2002	Yang et al.
9,808,246	B2	11/2017	2002/0110991	A1	8/2002	Li
9,812,319	B1	11/2017	2002/0112114	A1	8/2002	Blair et al.
9,812,320	B1	11/2017	2002/0114886	A1	8/2002	Chou et al.
9,859,151	B1	1/2018	2002/0115252	A1	8/2002	Haukka et al.
9,875,891	B2	1/2018	2002/0124883	A1	9/2002	Zheng
9,887,082	B1	2/2018	2002/0127350	A1	9/2002	Ishikawa et al.
9,890,456	B2	2/2018	2002/0134511	A1	9/2002	Ushioda et al.
9,891,521	B2	2/2018	2002/0136214	A1	9/2002	Do et al.
9,892,908	B2	2/2018	2002/0136909	A1	9/2002	Yang
9,892,913	B2	2/2018	2002/0139775	A1	10/2002	Chang
9,895,715	B2	2/2018	2002/0146512	A1	10/2002	Rossman
9,899,291	B2	2/2018	2002/0151327	A1	10/2002	Levitt
9,899,405	B2	2/2018	2002/0152244	A1	10/2002	Dean et al.
9,905,420	B2	2/2018	2002/0155219	A1	10/2002	Wang et al.
9,909,492	B2	2/2018	2002/0164420	A1	11/2002	Derderian et al.
9,909,214	B2	3/2018	2002/0172768	A1	11/2002	Endo et al.
9,911,676	B2	3/2018	2002/0174106	A1	11/2002	Martin
9,916,980	B1	3/2018	2002/0179011	A1	12/2002	Jonnalagadda et al.
9,929,011	B2	3/2018	2002/0184111	A1	12/2002	Swanson
9,960,072	B2	5/2018	2002/0187650	A1	12/2002	Blalock et al.
9,984,869	B1	5/2018	2002/0187656	A1	12/2002	Tan et al.
10,032,628	B2	6/2018	2002/0197849	A1	12/2002	Mandal
10,023,960	B2	7/2018	2003/0002562	A1	1/2003	Yerlikaya et al.
10,032,792	B2	7/2018	2003/0003607	A1	1/2003	Kagoshima
10,043,661	B2	8/2018	2003/0003635	A1	1/2003	Paranjpe et al.
10,053,774	B2	8/2018	2003/0003696	A1	1/2003	Gelatos et al.
10,083,836	B2	9/2018	2003/0010451	A1	1/2003	Tzu
10,087,522	B2	10/2018	2003/0010452	A1	1/2003	Park et al.
10,087,525	B2	10/2018	2003/0012632	A1	1/2003	Saeki
10,090,316	B2	10/2018	2003/0015294	A1	1/2003	Wang
10,103,040	B1	10/2018	2003/0015596	A1	1/2003	Evans
10,134,757	B2	11/2018	2003/0017268	A1	1/2003	Hu
RE47,170	E	12/2018	2003/0019428	A1	1/2003	Ku et al.
10,167,557	B2	1/2019	2003/0019580	A1	1/2003	Strang
2001/0001953	A1	5/2001	2003/0022468	A1	1/2003	Shioya et al.
2001/0003191	A1	6/2001	2003/0022523	A1	1/2003	Irino et al.
2001/0006070	A1	7/2001	2003/0023338	A1	1/2003	Chin et al.
2001/0007645	A1	7/2001	2003/0024901	A1	2/2003	Ishikawa
2001/0014514	A1	8/2001	2003/0025146	A1	2/2003	Narwankar et al.
2001/0017103	A1	8/2001	2003/0029303	A1	2/2003	Hasegawa et al.
2001/0018267	A1	8/2001	2003/0029381	A1	2/2003	Nishibayashi
2001/0019777	A1	9/2001	2003/0029475	A1	2/2003	Hua et al.
2001/0019900	A1	9/2001	2003/0035002	A1	2/2003	Moles
2001/0020715	A1	9/2001	2003/0036272	A1	2/2003	Shamouilian et al.
2001/0028924	A1	10/2001	2003/0040158	A1	2/2003	Saitoh
2001/0031535	A1	10/2001	2003/0040841	A1	2/2003	Nasr et al.
2001/0038783	A1	11/2001	2003/0042419	A1	3/2003	Katsumata et al.
2001/0040511	A1	11/2001	2003/0049375	A1	3/2003	Nguyen et al.
2001/0046765	A1	11/2001	2003/0049937	A1	3/2003	Suzuki
2001/0048981	A1	12/2001	2003/0054670	A1	3/2003	Wang et al.
2001/0049080	A1	12/2001	2003/0059535	A1	3/2003	Luo et al.

(56)		References Cited					
		U.S. PATENT DOCUMENTS					
2003/0059980	A1	3/2003	Chen et al.	2004/0101622	A1	5/2004	Park et al.
2003/0065413	A1	4/2003	Liteplo et al.	2004/0103914	A1	6/2004	Cheng et al.
2003/0066541	A1	4/2003	Sun et al.	2004/0106249	A1	6/2004	Huotari
2003/0066826	A1	4/2003	Lee et al.	2004/0124131	A1	7/2004	Aitchison
2003/0071015	A1	4/2003	Chinn et al.	2004/0124549	A1	7/2004	Curran
2003/0075925	A1	4/2003	Lindfors et al.	2004/0126990	A1	7/2004	Ohta
2003/0082296	A1	5/2003	Elers et al.	2004/0129211	A1	7/2004	Blonigan et al.
2003/0082307	A1	5/2003	Chung et al.	2004/0129671	A1	7/2004	Ji et al.
2003/0091938	A1	5/2003	Fairbairn et al.	2004/0134429	A1	7/2004	Yamanaka
2003/0094133	A1	5/2003	Yoshidome et al.	2004/0144311	A1	7/2004	Chen
2003/0109107	A1	6/2003	Hsieh et al.	2004/0144980	A1	7/2004	Ahn et al.
2003/0109951	A1	6/2003	Hsiung et al.	2004/0146644	A1	7/2004	Xia et al.
2003/0111963	A1	6/2003	Tolmachev et al.	2004/0151844	A1	8/2004	Zhang et al.
2003/0116087	A1	6/2003	Nguyen	2004/0151845	A1	8/2004	Nguyen et al.
2003/0168750	A1	6/2003	Basceri et al.	2004/0152287	A1	8/2004	Sherrill et al.
2003/0121608	A1	7/2003	Chen	2004/0159343	A1	8/2004	Shimbara et al.
2003/0133854	A1	7/2003	Tabata et al.	2004/0168627	A1	9/2004	Conley et al.
2003/0134038	A1	7/2003	Paranjpe	2004/0169032	A1	9/2004	Murayama et al.
2003/0141820	A1	7/2003	White et al.	2004/0187777	A1	9/2004	Okamoto et al.
2003/0143328	A1	7/2003	Chen	2004/0187790	A1	9/2004	Bader
2003/0157436	A1	8/2003	Manger et al.	2004/0187928	A1	9/2004	Ambrosina
2003/0159656	A1	8/2003	Tan	2004/0198069	A1	10/2004	Metzner et al.
2003/0162412	A1	8/2003	Chung	2004/0200499	A1	10/2004	Harvey et al.
2003/0168001	A1	9/2003	Sneh	2004/0203251	A1	10/2004	Kawaguchi et al.
2003/0168699	A1	9/2003	Honda	2004/0206305	A1	10/2004	Choi et al.
2003/0170583	A1	9/2003	Nakashima	2004/0209477	A1	10/2004	Buxbaum et al.
2003/0173490	A1	9/2003	Lappen	2004/0211357	A1	10/2004	Gadgil
2003/0180458	A1	9/2003	Sneh	2004/0212947	A1	10/2004	Nguyen
2003/0183156	A1	10/2003	Dando	2004/0213921	A1	10/2004	Leu
2003/0183856	A1	10/2003	Wieczorek et al.	2004/0214399	A1	10/2004	Ahn et al.
2003/0188685	A1	10/2003	Wang	2004/0214445	A1	10/2004	Shimizu et al.
2003/0192875	A1	10/2003	Bieker et al.	2004/0217217	A1	11/2004	Han et al.
2003/0198587	A1	10/2003	Kaloyeros	2004/0219793	A1	11/2004	Hishiya et al.
2003/0201541	A1	10/2003	Kim	2004/0221807	A1	11/2004	Verghese et al.
2003/0205202	A1	11/2003	Funaki et al.	2004/0231600	A1	11/2004	Lee
2003/0209323	A1	11/2003	Yokogaki	2004/0238523	A1	12/2004	Kuibira et al.
2003/0209326	A1	11/2003	Lee et al.	2004/0241998	A1	12/2004	Hanson
2003/0209746	A1	11/2003	Horii	2004/0247779	A1	12/2004	Selvamanickam et al.
2003/0211735	A1	11/2003	Rossmann	2004/0250600	A1	12/2004	Bevers et al.
2003/0217915	A1	11/2003	Ouellet	2004/0253867	A1	12/2004	Matsumoto
2003/0219972	A1	11/2003	Green	2004/0261712	A1	12/2004	Hayashi et al.
2003/0226840	A1	12/2003	Dalton	2004/0266011	A1	12/2004	Lee et al.
2003/0228772	A1	12/2003	Cowans	2005/0000428	A1	1/2005	Shero et al.
2003/0231698	A1	12/2003	Yamaguchi	2005/0003662	A1	1/2005	Jurisch et al.
2003/0232138	A1	12/2003	Tuominen et al.	2005/0008799	A1	1/2005	Tomiyasu et al.
2003/0232491	A1	12/2003	Yamaguchi	2005/0019026	A1	1/2005	Wang et al.
2004/0002224	A1	1/2004	Chono et al.	2005/0019494	A1	1/2005	Moghadam et al.
2004/0009307	A1	1/2004	Koh et al.	2005/0020071	A1	1/2005	Sonobe et al.
2004/0009679	A1	1/2004	Yeo et al.	2005/0023624	A1	2/2005	Ahn et al.
2004/0010772	A1	1/2004	McKenna et al.	2005/0034674	A1	2/2005	Ono
2004/0013577	A1	1/2004	Ganguli et al.	2005/0037154	A1	2/2005	Koh et al.
2004/0013818	A1	1/2004	Moon et al.	2005/0037610	A1	2/2005	Cha
2004/0016637	A1	1/2004	Yang	2005/0042778	A1	2/2005	Peukert
2004/0018304	A1	1/2004	Chung et al.	2005/0048797	A1	3/2005	Fukazawa
2004/0018307	A1	1/2004	Park et al.	2005/0051093	A1	3/2005	Makino et al.
2004/0018723	A1	1/2004	Byun et al.	2005/0054228	A1	3/2005	March
2004/0018750	A1	1/2004	Sophie et al.	2005/0056218	A1*	3/2005	Sun C04B 41/009
2004/0023516	A1	2/2004	Londergan et al.				118/715
2004/0026372	A1	2/2004	Takenaka et al.	2005/0059262	A1	3/2005	Yin et al.
2004/0029052	A1	2/2004	Park et al.	2005/0064207	A1	3/2005	Senzaki et al.
2004/0036129	A1	2/2004	Forbes et al.	2005/0064719	A1	3/2005	Liu
2004/0037675	A1	2/2004	Zinger et al.	2005/0066893	A1	3/2005	Soininen
2004/0048439	A1	3/2004	Soman	2005/0069651	A1	3/2005	Miyoshi
2004/0048492	A1	3/2004	Ishikawa et al.	2005/0070123	A1	3/2005	Hirano
2004/0050325	A1	3/2004	Samoilov	2005/0070729	A1	3/2005	Kiyomori et al.
2004/0062081	A1	4/2004	Drewes	2005/0072357	A1	4/2005	Shero et al.
2004/0063289	A1	4/2004	Ohta	2005/0074983	A1	4/2005	Shinriki et al.
2004/0071897	A1	4/2004	Verplancken et al.	2005/0092247	A1	5/2005	Schmidt
2004/0077182	A1	4/2004	Lim et al.	2005/0092249	A1	5/2005	Kilpela et al.
2004/0079960	A1	4/2004	Shakuda	2005/0092733	A1	5/2005	Ito et al.
2004/0080697	A1	4/2004	Song	2005/0095770	A1	5/2005	Kumagai et al.
2004/0082171	A1	4/2004	Shin et al.	2005/0098107	A1	5/2005	Du Bois et al.
2004/0087141	A1	5/2004	Ramanathan et al.	2005/0100669	A1	5/2005	Kools et al.
2004/0094402	A1	5/2004	Gopalraja	2005/0101154	A1	5/2005	Huang
2004/0099213	A1	5/2004	Adomaitis et al.	2005/0101843	A1	5/2005	Quinn et al.
				2005/0106893	A1	5/2005	Wilk
				2005/0110069	A1	5/2005	Kil et al.
				2005/0118804	A1	6/2005	Byun et al.
				2005/0118837	A1	6/2005	Todd

(56)		References Cited					
		U.S. PATENT DOCUMENTS					
2005/0120805	A1	6/2005	Lane	2006/0060930	A1	3/2006	Metz et al.
2005/0120962	A1	6/2005	Ushioda et al.	2006/0062910	A1	3/2006	Meiere
2005/0123690	A1	6/2005	Derderian et al.	2006/0063346	A1	3/2006	Lee et al.
2005/0130427	A1	6/2005	Seok-Jun	2006/0068104	A1	3/2006	Ishizaka
2005/0132957	A1	6/2005	El-Raghy	2006/0068121	A1	3/2006	Lee et al.
2005/0133161	A1	6/2005	Carpenter et al.	2006/0068125	A1	3/2006	Radhakrishnan
2005/0141591	A1	6/2005	Sakano	2006/0087638	A1	4/2006	Hirayanagi
2005/0142361	A1	6/2005	Nakanishi	2006/0096540	A1	5/2006	Choi
2005/0145338	A1	7/2005	Park et al.	2006/0099782	A1	5/2006	Ritenour
2005/0153571	A1	7/2005	Senzaki	2006/0105566	A1	5/2006	Waldfried et al.
2005/0172895	A1	8/2005	Kijima et al.	2006/0107898	A1	5/2006	Blomberg
2005/0173003	A1	8/2005	Laverdiere et al.	2006/0110934	A1	5/2006	Fukuchi
2005/0175789	A1	8/2005	Helms	2006/0113675	A1	6/2006	Chang et al.
2005/0181535	A1	8/2005	Yun et al.	2006/0113806	A1	6/2006	Tsuji et al.
2005/0181555	A1	8/2005	Haukka et al.	2006/0128142	A1	6/2006	Whelan et al.
2005/0187647	A1	8/2005	Wang et al.	2006/0128168	A1	6/2006	Ahn et al.
2005/0191828	A1	9/2005	Al-Bayati et al.	2006/0130767	A1	6/2006	Herchen
2005/0199013	A1	9/2005	Vandroux et al.	2006/0137609	A1	6/2006	Puchacz et al.
2005/0208718	A1	9/2005	Lim et al.	2006/0147626	A1	7/2006	Blomberg
2005/0211167	A1	9/2005	Gunji	2006/0148180	A1	7/2006	Ahn et al.
2005/0212119	A1	9/2005	Shero	2006/0154424	A1	7/2006	Yang et al.
2005/0214457	A1	9/2005	Schmitt et al.	2006/0156981	A1	7/2006	Fondurulia
2005/0214458	A1	9/2005	Meiere	2006/0163612	A1	7/2006	Kouvetakis et al.
2005/0208778	A1	10/2005	Li	2006/0166428	A1	7/2006	Kamioka
2005/0218462	A1	10/2005	Ahn et al.	2006/0172531	A1	8/2006	Lin et al.
2005/0221021	A1	10/2005	Strang	2006/0175669	A1	8/2006	Kim et al.
2005/0221618	A1	10/2005	AmRhein et al.	2006/0177855	A1	8/2006	Utermohlen
2005/0223982	A1	10/2005	Park et al.	2006/0182885	A1	8/2006	Lei et al.
2005/0223994	A1	10/2005	Blomiley et al.	2006/0188360	A1	8/2006	Bonora et al.
2005/0227502	A1	10/2005	Schmitt et al.	2006/0191555	A1	8/2006	Yoshida et al.
2005/0229848	A1	10/2005	Shinriki	2006/0193979	A1	8/2006	Meiere et al.
2005/0229849	A1	10/2005	Silvetti et al.	2006/0196420	A1	9/2006	Ushakov et al.
2005/0229972	A1	10/2005	Hoshi et al.	2006/0199357	A1	9/2006	Wan et al.
2005/0233477	A1	10/2005	Yamazaki et al.	2006/0205223	A1	9/2006	Smayling
2005/0241176	A1	11/2005	Shero et al.	2006/0205231	A1	9/2006	Chou et al.
2005/0241763	A1	11/2005	Huang et al.	2006/0208215	A1	9/2006	Metzner et al.
2005/0245058	A1	11/2005	Lee et al.	2006/0211243	A1	9/2006	Ishizaka et al.
2005/0249876	A1	11/2005	Kawahara et al.	2006/0211259	A1	9/2006	Maes
2005/0250340	A1	11/2005	Chen et al.	2006/0213439	A1	9/2006	Ishizaka
2005/0251990	A1	11/2005	Choi	2006/0216942	A1	9/2006	Kim et al.
2005/0252447	A1*	11/2005	Zhao C23C 16/45565 118/715	2006/0219169	A1	10/2006	Chen et al.
2005/0252449	A1	11/2005	Nguyen et al.	2006/0223301	A1	10/2006	Vanhaelemeersch et al.
2005/0255257	A1	11/2005	Choi et al.	2006/0226117	A1	10/2006	Bertram et al.
2005/0258280	A1	11/2005	Goto et al.	2006/0228496	A1	10/2006	Choi
2005/0260347	A1	11/2005	Narwankar et al.	2006/0228863	A1	10/2006	Zhang et al.
2005/0260850	A1	11/2005	Loke	2006/0228888	A1	10/2006	Lee et al.
2005/0263072	A1	12/2005	Balasubramanian et al.	2006/0236934	A1	10/2006	Choi et al.
2005/0263075	A1	12/2005	Wang et al.	2006/0240574	A1	10/2006	Yoshie
2005/0263932	A1	12/2005	Heugel	2006/0240662	A1	10/2006	Conley et al.
2005/0271813	A1	12/2005	Kher et al.	2006/0249253	A1	11/2006	Dando
2005/0274323	A1	12/2005	Seidel et al.	2006/0251827	A1	11/2006	Nowak
2005/0277271	A1	12/2005	Beintner	2006/0252228	A1	11/2006	Jeng
2005/0282101	A1	12/2005	Adachi	2006/0252351	A1	11/2006	Kundracik
2005/0285097	A1	12/2005	Shang et al.	2006/0257563	A1	11/2006	Doh et al.
2005/0287725	A1	12/2005	Kitagawa	2006/0257584	A1	11/2006	Derderian et al.
2005/0287771	A1	12/2005	Seamons et al.	2006/0258078	A1	11/2006	Lee et al.
2006/0000411	A1	1/2006	Seo	2006/0258173	A1	11/2006	Xiao et al.
2006/0013674	A1	1/2006	Elliott et al.	2006/0260545	A1	11/2006	Ramaswamy et al.
2006/0013946	A1	1/2006	Park et al.	2006/0263522	A1	11/2006	Byun
2006/0014384	A1	1/2006	Lee et al.	2006/0264060	A1	11/2006	Ramaswamy et al.
2006/0014397	A1	1/2006	Seamons et al.	2006/0264066	A1	11/2006	Bartholomew
2006/0016783	A1	1/2006	Wu et al.	2006/0266289	A1	11/2006	Verghese et al.
2006/0019033	A1	1/2006	Muthukrishnan et al.	2006/0269690	A1	11/2006	Watanabe et al.
2006/0019502	A1	1/2006	Park et al.	2006/0269692	A1	11/2006	Balseanu
2006/0021572	A1	2/2006	Wolden	2006/0275933	A1	12/2006	Du Bois et al.
2006/0021703	A1	2/2006	Umotoy et al.	2006/0278524	A1	12/2006	Stowell
2006/0024439	A2	2/2006	Tuominen et al.	2006/0283629	A1	12/2006	Kikuchi et al.
2006/0026314	A1	2/2006	Franchuk et al.	2006/0286774	A1	12/2006	Singh et al.
2006/0040054	A1	2/2006	Pearlstein et al.	2006/0286775	A1	12/2006	Singh et al.
2006/0040508	A1	2/2006	Ji	2006/0286817	A1	12/2006	Kato et al.
2006/0046518	A1	3/2006	Hill et al.	2006/0286818	A1	12/2006	Wang et al.
2006/0051520	A1	3/2006	Behle et al.	2006/0286819	A1	12/2006	Seutter
2006/0051925	A1	3/2006	Ahn et al.	2006/0291982	A1	12/2006	Tanaka
2006/0057828	A1	3/2006	Omura	2007/0006806	A1	1/2007	Imai
				2007/0010072	A1	1/2007	Bailey et al.
				2007/0012402	A1	1/2007	Sneh
				2007/0020167	A1	1/2007	Han et al.
				2007/0020830	A1	1/2007	Speranza
				2007/0020953	A1	1/2007	Tsai et al.

(56)

References Cited

U.S. PATENT DOCUMENTS

2007/0022954	A1	2/2007	Iizuka et al.	2007/0232071	A1	10/2007	Balseanu et al.
2007/0026148	A1	2/2007	Arai et al.	2007/0232501	A1	10/2007	Tonomura
2007/0028842	A1	2/2007	Inagawa et al.	2007/0234955	A1	10/2007	Suzuki et al.
2007/0031598	A1	2/2007	Okuyama et al.	2007/0237697	A1	10/2007	Clark
2007/0031599	A1	2/2007	Gschwandtner et al.	2007/0237698	A1	10/2007	Clark
2007/0032045	A1	2/2007	Kasahara et al.	2007/0237699	A1	10/2007	Clark
2007/0032082	A1	2/2007	Ramaswamy et al.	2007/0241688	A1	10/2007	DeVincentis et al.
2007/0034477	A1	2/2007	Inui	2007/0248767	A1	10/2007	Okura
2007/0037343	A1	2/2007	Colombo et al.	2007/0249131	A1	10/2007	Allen et al.
2007/0037412	A1	2/2007	Dip et al.	2007/0251444	A1	11/2007	Gros-Jean et al.
2007/0042117	A1	2/2007	Kupurao et al.	2007/0251456	A1	11/2007	Herchen et al.
2007/0049053	A1	3/2007	Mahajani	2007/0252244	A1	11/2007	Srividya et al.
2007/0054499	A1	3/2007	Jang	2007/0252532	A1	11/2007	DeVincentis et al.
2007/0056843	A1	3/2007	Ye et al.	2007/0258506	A1	11/2007	Schwagerman et al.
2007/0056850	A1	3/2007	Ye et al.	2007/0264807	A1	11/2007	Leone et al.
2007/0059948	A1	3/2007	Metzner et al.	2007/0266945	A1	11/2007	Shuto et al.
2007/0062439	A1	3/2007	Wada et al.	2007/0269983	A1	11/2007	Sneh
2007/0062453	A1	3/2007	Ishikawa	2007/0275166	A1	11/2007	Thridandam et al.
2007/0065578	A1	3/2007	McDougall	2007/0277735	A1	12/2007	Mokhesi et al.
2007/0066010	A1	3/2007	Ando	2007/0281082	A1	12/2007	Mokhesi et al.
2007/0066079	A1	3/2007	Kolster et al.	2007/0281105	A1	12/2007	Mokhesi et al.
2007/0066084	A1	3/2007	Wajda et al.	2007/0281496	A1	12/2007	Ingle et al.
2007/0077355	A1	4/2007	Chacin et al.	2007/0298362	A1	12/2007	Rocha-Alvarez et al.
2007/0082132	A1	4/2007	Shinriki	2008/0003824	A1	1/2008	Padhi et al.
2007/0082500	A1	4/2007	Norman et al.	2008/0003838	A1	1/2008	Haukka et al.
2007/0084405	A1	4/2007	Kim	2008/0006208	A1	1/2008	Ueno et al.
2007/0087579	A1	4/2007	Kitayama et al.	2008/0018004	A1	1/2008	Steidl
2007/0089670	A1	4/2007	Ikedo	2008/0020591	A1	1/2008	Balseanu et al.
2007/0096194	A1	5/2007	Streck et al.	2008/0020593	A1	1/2008	Wang et al.
2007/0098527	A1	5/2007	Hall et al.	2008/0023436	A1	1/2008	Gros-Jean et al.
2007/0107845	A1	5/2007	Ishizawa et al.	2008/0026574	A1	1/2008	Brcka
2007/0111470	A1	5/2007	Smythe	2008/0026597	A1	1/2008	Munro et al.
2007/0111545	A1	5/2007	Lee et al.	2008/0029790	A1	2/2008	Ahn et al.
2007/0116873	A1	5/2007	Li et al.	2008/0031708	A1	2/2008	Bonora et al.
2007/0116888	A1	5/2007	Faguet	2008/0036354	A1	2/2008	Letz et al.
2007/0119370	A1	5/2007	Ma et al.	2008/0038485	A1	2/2008	Fukazawa et al.
2007/0123037	A1	5/2007	Lee et al.	2008/0038934	A1	2/2008	Vrtis et al.
2007/0123189	A1	5/2007	Saito et al.	2008/0042165	A1	2/2008	Sugizaki
2007/0125762	A1	6/2007	Cui et al.	2008/0043803	A1	2/2008	Bandoh
2007/0128538	A1	6/2007	Fairbairn et al.	2008/0050536	A1	2/2008	Aing et al.
2007/0128876	A1	6/2007	Fukiage	2008/0050538	A1	2/2008	Hirata
2007/0128888	A1	6/2007	Goto et al.	2008/0054332	A1	3/2008	Kim et al.
2007/0129621	A1	6/2007	Kellogg et al.	2008/0054813	A1	3/2008	Espiau et al.
2007/0131168	A1*	6/2007	Gomi C23C 16/45565 118/715	2008/0056860	A1	3/2008	Natume
2007/0134942	A1	6/2007	Ahn et al.	2008/0057659	A1	3/2008	Forbes et al.
2007/0137794	A1	6/2007	Qiu et al.	2008/0061667	A1	3/2008	Gaertner et al.
2007/0146621	A1	6/2007	Yeom	2008/0066778	A1	3/2008	Matsushita et al.
2007/0148350	A1	6/2007	Rahtu	2008/0069955	A1	3/2008	Hong et al.
2007/0148990	A1	6/2007	Deboer et al.	2008/0075562	A1	3/2008	Maria et al.
2007/0155138	A1	7/2007	Tomasini et al.	2008/0075881	A1	3/2008	Won et al.
2007/0157466	A1	7/2007	Kida et al.	2008/0076070	A1	3/2008	Koh et al.
2007/0158026	A1	7/2007	Amikura	2008/0076266	A1	3/2008	Fukazawa et al.
2007/0163440	A1	7/2007	Kim et al.	2008/0081104	A1	4/2008	Hasebe et al.
2007/0163625	A1	7/2007	Lee	2008/0081113	A1	4/2008	Clark
2007/0166457	A1	7/2007	Yamoto et al.	2008/0081121	A1	4/2008	Morita et al.
2007/0166966	A1	7/2007	Todd et al.	2008/0085226	A1	4/2008	Fondurulia et al.
2007/0166999	A1	7/2007	Vaarstra	2008/0092815	A1	4/2008	Chen et al.
2007/0173071	A1	7/2007	Afzali-Ardakani et al.	2008/0102203	A1	5/2008	Wu
2007/0175393	A1	8/2007	Nishimura et al.	2008/0113094	A1	5/2008	Casper
2007/0175397	A1	8/2007	Tomiyasu et al.	2008/0113096	A1	5/2008	Mahajani
2007/0178235	A1	8/2007	Yamada et al.	2008/0113097	A1	5/2008	Mahajani et al.
2007/0186849	A1	8/2007	Furuya	2008/0118334	A1	5/2008	Bonora
2007/0186952	A1	8/2007	Honda et al.	2008/0121177	A1	5/2008	Bang et al.
2007/0187363	A1	8/2007	Oka et al.	2008/0121626	A1	5/2008	Thomas et al.
2007/0202678	A1	8/2007	Plombon et al.	2008/0124197	A1	5/2008	van der Meulen et al.
2007/0207275	A1	9/2007	Nowak et al.	2008/0124908	A1	5/2008	Forbes et al.
2007/0209590	A1	9/2007	Li	2008/0124946	A1	5/2008	Xiao et al.
2007/0210890	A1	9/2007	Hsu et al.	2008/0132046	A1	6/2008	Walther
2007/0215048	A1	9/2007	Suzuki et al.	2008/0133154	A1	6/2008	Krauss et al.
2007/0218200	A1	9/2007	Suzuki et al.	2008/0142483	A1	6/2008	Hua
2007/0218705	A1	9/2007	Matsuki et al.	2008/0149031	A1	6/2008	Chu et al.
2007/0224777	A1	9/2007	Hamelin	2008/0149593	A1	6/2008	Bai et al.
2007/0224833	A1	9/2007	Morisada et al.	2008/0152463	A1	6/2008	Chidambaram et al.
2007/0232031	A1	10/2007	Singh et al.	2008/0153311	A1	6/2008	Padhi et al.
				2008/0157157	A1	7/2008	Tonomura
				2008/0157365	A1	7/2008	Ott et al.
				2008/0173237	A1	7/2008	Collins
				2008/0173238	A1	7/2008	Nakashima et al.
				2008/0173240	A1	7/2008	Furukawahara

(56)		References Cited					
		U.S. PATENT DOCUMENTS					
2008/0173326	A1	7/2008	Gu et al.	2009/0085156	A1	4/2009	Dewey et al.
2008/0176375	A1	7/2008	Erben et al.	2009/0090382	A1	4/2009	Morisada
2008/0178805	A1	7/2008	Paterson et al.	2009/0093094	A1	4/2009	Ye et al.
2008/0179104	A1	7/2008	Zhang	2009/0095221	A1	4/2009	Tam et al.
2008/0179715	A1	7/2008	Coppa	2009/0104351	A1	4/2009	Kakegawa
2008/0182075	A1	7/2008	Chopra	2009/0104789	A1	4/2009	Mallick et al.
2008/0182390	A1	7/2008	Lemmi et al.	2009/0107404	A1	4/2009	Ogliari et al.
2008/0191193	A1	8/2008	Li et al.	2009/0108308	A1	4/2009	Yang et al.
2008/0199977	A1	8/2008	Weigel et al.	2009/0112458	A1	4/2009	Nakai
2008/0202416	A1	8/2008	Provencher	2009/0115064	A1	5/2009	Sandhu et al.
2008/0202689	A1	8/2008	Kim	2009/0120580	A1	5/2009	Kagoshima et al.
2008/0203487	A1	8/2008	Hohage et al.	2009/0122293	A1	5/2009	Shibazaki
2008/0205483	A1	8/2008	Rempe et al.	2009/0122458	A1	5/2009	Lischer et al.
2008/0211423	A1	9/2008	Shinmen et al.	2009/0124131	A1	5/2009	Breunsbach et al.
2008/0211526	A1	9/2008	Shinma	2009/0130331	A1	5/2009	Asai
2008/0216077	A1	9/2008	Emani et al.	2009/0130859	A1	5/2009	Itatani et al.
2008/0216742	A1	9/2008	Takebayashi	2009/0136668	A1	5/2009	Gregg et al.
2008/0220619	A1	9/2008	Matsushita et al.	2009/0136683	A1	5/2009	Fukasawa et al.
2008/0224240	A1	9/2008	Ahn et al.	2009/0139657	A1	6/2009	Lee et al.
2008/0228306	A1	9/2008	Yetter et al.	2009/0142905	A1	6/2009	Yamazaki
2008/0233288	A1	9/2008	Clark	2009/0142935	A1	6/2009	Fukazawa et al.
2008/0237572	A1	10/2008	Chui et al.	2009/0146322	A1	6/2009	Weling et al.
2008/0241384	A1	10/2008	Jeong	2009/0156015	A1	6/2009	Park et al.
2008/0241387	A1	10/2008	Keto	2009/0159000	A1	6/2009	Aggarwal et al.
2008/0242116	A1	10/2008	Clark	2009/0159002	A1*	6/2009	Bera
2008/0248310	A1	10/2008	Kim et al.				C23C 16/45585
2008/0257494	A1	10/2008	Hayashi et al.	2009/0159424	A1	6/2009	Liu et al.
2008/0260963	A1	10/2008	Yoon et al.	2009/0162996	A1	6/2009	Ramaswamy et al.
2008/0261413	A1	10/2008	Mahajani	2009/0163038	A1	6/2009	Miyoshi
2008/0264337	A1	10/2008	Sano et al.	2009/0165715	A1	7/2009	Oh
2008/0267598	A1	10/2008	Nakamura	2009/0179365	A1	7/2009	Lerner et al.
2008/0268635	A1	10/2008	Yu et al.	2009/0186571	A1	7/2009	Haro
2008/0277715	A1	11/2008	Ohmi et al.	2009/0197015	A1	8/2009	Kudela et al.
2008/0282970	A1	11/2008	Heys et al.	2009/0200494	A1	8/2009	Hatem
2008/0283962	A1	11/2008	Dyer	2009/0204403	A1	8/2009	Hollander et al.
2008/0289574	A1	11/2008	Jacobs et al.	2009/0206056	A1	8/2009	Xu
2008/0291964	A1	11/2008	Shrimpling	2009/0209081	A1	8/2009	Matero
2008/0295872	A1	12/2008	Riker et al.	2009/0211523	A1	8/2009	Kuppuraao et al.
2008/0298945	A1	12/2008	Cox	2009/0211525	A1	8/2009	Sarigiannis et al.
2008/0299326	A1	12/2008	Fukazawa	2009/0227094	A1	9/2009	Bateman
2008/0299758	A1	12/2008	Harada et al.	2009/0230211	A1	9/2009	Kobayashi et al.
2008/0302303	A1	12/2008	Choi et al.	2009/0236014	A1	9/2009	Wilson
2008/0305014	A1	12/2008	Honda	2009/0236276	A1	9/2009	Kurth et al.
2008/0305246	A1	12/2008	Choi et al.	2009/0239386	A1	9/2009	Suzaki et al.
2008/0305443	A1	12/2008	Nakamura	2009/0242957	A1	10/2009	Ma et al.
2008/0315292	A1	12/2008	Ji et al.	2009/0246374	A1	10/2009	Vukovic
2008/0317972	A1	12/2008	Hendriks	2009/0246399	A1	10/2009	Goundar
2009/0000550	A1	1/2009	Tran et al.	2009/0246971	A1	10/2009	Reid et al.
2009/0000551	A1	1/2009	Choi et al.	2009/0250955	A1	10/2009	Aoki
2009/0011145	A1	1/2009	Yun	2009/0255901	A1	10/2009	Okita
2009/0011608	A1	1/2009	Nabatame	2009/0261331	A1	10/2009	Yang et al.
2009/0017631	A1	1/2009	Bencher	2009/0269506	A1	10/2009	Okura et al.
2009/0020072	A1	1/2009	Mizunaga et al.	2009/0269941	A1	10/2009	Raisanen
2009/0023229	A1	1/2009	Matsushita	2009/0275205	A1	11/2009	Kiehlbauch et al.
2009/0029503	A1	1/2009	Arai	2009/0277510	A1	11/2009	Shikata
2009/0029528	A1	1/2009	Sanchez et al.	2009/0283041	A1	11/2009	Tomiyasu et al.
2009/0029564	A1	1/2009	Yamashita et al.	2009/0283217	A1	11/2009	Lubomirsky et al.
2009/0033907	A1	2/2009	Watson	2009/0284156	A1	11/2009	Hanna et al.
2009/0035947	A1	2/2009	Horii	2009/0286400	A1	11/2009	Heo et al.
2009/0041952	A1	2/2009	Yoon et al.	2009/0286402	A1	11/2009	Xia et al.
2009/0041984	A1	2/2009	Mayers et al.	2009/0289300	A1	11/2009	Sasaki et al.
2009/0042344	A1	2/2009	Ye et al.	2009/0302434	A1	12/2009	Pallem et al.
2009/0042408	A1	2/2009	Maeda	2009/0304558	A1	12/2009	Patton
2009/0045829	A1	2/2009	Awazu	2009/0308315	A1	12/2009	de Ridder
2009/0050621	A1	2/2009	Awazu	2009/0308425	A1	12/2009	Yednak
2009/0052498	A1	2/2009	Halpin et al.	2009/0311857	A1	12/2009	Todd et al.
2009/0053023	A1	2/2009	Wakabayashi	2009/0315093	A1	12/2009	Li et al.
2009/0053906	A1	2/2009	Miya et al.	2009/0320754	A1	12/2009	Oya
2009/0056629	A1	3/2009	Katz et al.	2009/0324971	A1	12/2009	De Vries et al.
2009/0057269	A1	3/2009	Katz et al.	2009/0325391	A1	12/2009	De Vusser et al.
2009/0061083	A1	3/2009	Chiang et al.	2009/0325469	A1	12/2009	Koo et al.
2009/0061644	A1	3/2009	Chiang et al.	2010/0001409	A1	1/2010	Humbert et al.
2009/0061647	A1	3/2009	Mallick et al.	2010/0003406	A1	1/2010	Lam et al.
2009/0075491	A1	3/2009	Liu et al.	2010/0006031	A1	1/2010	Choi et al.
2009/0084317	A1	4/2009	Wu	2010/0006923	A1	1/2010	Fujitsuka
				2010/0014479	A1	1/2010	Kim
				2010/0015813	A1	1/2010	McGinnis et al.
				2010/0018460	A1	1/2010	Singh et al.
				2010/0024727	A1	2/2010	Kim et al.

118/715

(56)

References Cited

U.S. PATENT DOCUMENTS

2010/0024872	A1	2/2010	Kishimoto	2010/0255198	A1	10/2010	Cleary et al.
2010/0025796	A1	2/2010	Dabiran	2010/0255218	A1	10/2010	Oka et al.
2010/0032587	A1	2/2010	Hosch et al.	2010/0255625	A1	10/2010	De Vries
2010/0032842	A1	2/2010	Herd et al.	2010/0255658	A1	10/2010	Aggarwal
2010/0040441	A1	2/2010	Obikane	2010/0259152	A1	10/2010	Yasuda et al.
2010/0041179	A1	2/2010	Lee	2010/0266765	A1	10/2010	White et al.
2010/0041243	A1	2/2010	Cheng et al.	2010/0267248	A1	10/2010	Ma et al.
2010/0050943	A1	3/2010	Kato et al.	2010/0270675	A1	10/2010	Harada
2010/0051597	A1	3/2010	Morita et al.	2010/0246630	A1	11/2010	Kaszynski et al.
2010/0055312	A1	3/2010	Kato et al.	2010/0275846	A1	11/2010	Kitagawa
2010/0055442	A1	3/2010	Kellock	2010/0282163	A1	11/2010	Aggarwal et al.
2010/0058984	A1	3/2010	Marubayashi	2010/0282170	A1	11/2010	Nishizawa
2010/0065758	A1	3/2010	Liu et al.	2010/0282645	A1	11/2010	Wang
2010/0068009	A1	3/2010	Kimura	2010/0285237	A1	11/2010	Ditizio et al.
2010/0068891	A1	3/2010	Hatanaka et al.	2010/0285319	A1	11/2010	Kwak et al.
2010/0075037	A1	3/2010	Marsh et al.	2010/0294199	A1	11/2010	Tran et al.
2010/0075507	A1	3/2010	Chang et al.	2010/0297391	A1	11/2010	Kley
2010/0081094	A1	4/2010	Hasebe et al.	2010/0301752	A1	12/2010	Bakre et al.
2010/0089320	A1	4/2010	Kim	2010/0304047	A1	12/2010	Yang et al.
2010/0089870	A1	4/2010	Hiroshima et al.	2010/0307415	A1	12/2010	Shero et al.
2010/0090149	A1	4/2010	Thompson et al.	2010/0317198	A1	12/2010	Antonelli
2010/0092696	A1	4/2010	Shinriki	2010/0322604	A1	12/2010	Fondurulia et al.
2010/0093187	A1	4/2010	Lee et al.	2010/0326358	A1	12/2010	Choi
2010/0098862	A1	4/2010	Xu et al.	2011/0000619	A1	1/2011	Suh
2010/0102417	A1	4/2010	Ganguli et al.	2011/0006402	A1	1/2011	Zhou
2010/0105936	A1	4/2010	Tada et al.	2011/0006406	A1	1/2011	Urbanowicz et al.
2010/0112496	A1	5/2010	Nakajima et al.	2011/0014359	A1	1/2011	Hashim
2010/0116207	A1	5/2010	Givens	2011/0014795	A1	1/2011	Lee
2010/0116209	A1	5/2010	Kato	2011/0027725	A1	2/2011	Tsutsumi et al.
2010/0124610	A1	5/2010	Aikawa et al.	2011/0027999	A1	2/2011	Sparks et al.
2010/0124618	A1	5/2010	Kobayashi et al.	2011/0034039	A1	2/2011	Liang et al.
2010/0124621	A1	5/2010	Kobayashi et al.	2011/0045610	A1	2/2011	van Schravendijk
2010/0126415	A1	5/2010	Ishino et al.	2011/0046314	A1	2/2011	Klipp et al.
2010/0126539	A1	5/2010	Lee et al.	2011/0048642	A1	3/2011	Mihara et al.
2010/0126605	A1	5/2010	Stones	2011/0048769	A1	3/2011	Fujwara
2010/0129990	A1	5/2010	Nishizawa et al.	2011/0049100	A1	3/2011	Han et al.
2010/0130015	A1	5/2010	Nakajima et al.	2011/0052833	A1	3/2011	Hanawa et al.
2010/0130017	A1	5/2010	Luo et al.	2011/0053383	A1	3/2011	Shero et al.
2010/0130105	A1	5/2010	Lee	2011/0056513	A1	3/2011	Hombach et al.
2010/0134023	A1	6/2010	Mills	2011/0056626	A1	3/2011	Brown et al.
2010/0136216	A1	6/2010	Tsuei et al.	2011/0057248	A1	3/2011	Ma et al.
2010/0140221	A1	6/2010	Kikuchi et al.	2011/0061810	A1	3/2011	Ganguly et al.
2010/0143609	A1	6/2010	Fukazawa et al.	2011/0070380	A1	3/2011	Shero et al.
2010/0144162	A1	6/2010	Lee et al.	2011/0081519	A1	4/2011	Dillingh
2010/0144968	A1	6/2010	Lee et al.	2011/0083496	A1	4/2011	Lin et al.
2010/0145547	A1	6/2010	Darabnia et al.	2011/0086516	A1	4/2011	Lee et al.
2010/0151206	A1	6/2010	Wu et al.	2011/0089469	A1	4/2011	Merckling
2010/0159638	A1	6/2010	Jeong	2011/0097901	A1	4/2011	Banna et al.
2010/0162752	A1	7/2010	Tabata et al.	2011/0107512	A1	5/2011	Gilbert
2010/0162956	A1	7/2010	Murakami et al.	2011/0108194	A1	5/2011	Yoshioka et al.
2010/0163524	A1	7/2010	Arai	2011/0108741	A1	5/2011	Ingram
2010/0163937	A1	7/2010	Clendinning	2011/0108929	A1	5/2011	Meng
2010/0168404	A1	7/2010	Girolami et al.	2011/0117490	A1	5/2011	Bae et al.
2010/0170441	A1	7/2010	Won et al.	2011/0117737	A1	5/2011	Agarwala et al.
2010/0170868	A1	7/2010	Lin et al.	2011/0117749	A1	5/2011	Sheu
2010/0173432	A1	7/2010	White et al.	2011/0124196	A1	5/2011	Lee
2010/0178137	A1	7/2010	Chintalapati et al.	2011/0139272	A1	6/2011	Matsumoto et al.
2010/0178423	A1	7/2010	Shimizu et al.	2011/0139748	A1	6/2011	Donnelly et al.
2010/0180819	A1	7/2010	Hatanaka et al.	2011/0140172	A1	6/2011	Chu
2010/0183825	A1	7/2010	Becker et al.	2011/0143032	A1	6/2011	Vrtis et al.
2010/0184302	A1	7/2010	Lee et al.	2011/0143461	A1	6/2011	Fish et al.
2010/0186669	A1	7/2010	Shin et al.	2011/0159202	A1	6/2011	Matsushita
2010/0193501	A1	8/2010	Zucker et al.	2011/0159673	A1	6/2011	Hanawa et al.
2010/0195392	A1	8/2010	Freeman	2011/0159680	A1	6/2011	Yoo
2010/0202860	A1	8/2010	Reed	2011/0168330	A1	7/2011	Sakaue et al.
2010/0221452	A1	9/2010	Kang	2011/0171775	A1	7/2011	Yamamoto et al.
2010/0229795	A1	9/2010	Tanabe	2011/0175011	A1	7/2011	Ehrne et al.
2010/0230051	A1	9/2010	Iizuka	2011/0180233	A1	7/2011	Bera et al.
2010/0230863	A1	9/2010	Moench et al.	2011/0183079	A1	7/2011	Jackson et al.
2010/0233885	A1	9/2010	Kushibiki et al.	2011/0183269	A1	7/2011	Zhu
2010/0233886	A1	9/2010	Yang et al.	2011/0183527	A1	7/2011	Cho
2010/0236691	A1	9/2010	Yamazaki	2011/0192820	A1	8/2011	Yeom et al.
2010/0243166	A1	9/2010	Hayashi et al.	2011/0198417	A1	8/2011	Detmar et al.
2010/0244688	A1	9/2010	Braun et al.	2011/0198736	A1	8/2011	Shero et al.
2010/0248465	A1	9/2010	Yi et al.	2011/0210468	A1	9/2011	Shannon et al.
				2011/0220874	A1	9/2011	Hanrath
				2011/0236600	A1	9/2011	Fox et al.
				2011/0237040	A1	9/2011	Ng et al.
				2011/0239936	A1	10/2011	Suzaki et al.

(56)		References Cited					
		U.S. PATENT DOCUMENTS					
2011/0253044	A1	10/2011	Tam et al.	2012/0180954	A1	7/2012	Yang et al.
2011/0254052	A1	10/2011	Kouvetakis	2012/0183689	A1	7/2012	Suzuki et al.
2011/0256675	A1	10/2011	Avouris	2012/0187083	A1	7/2012	Hashizume
2011/0256726	A1	10/2011	Lavoie et al.	2012/0187305	A1	7/2012	Elam et al.
2011/0256727	A1	10/2011	Beynet et al.	2012/0190178	A1	7/2012	Wang et al.
2011/0256734	A1	10/2011	Hausmann et al.	2012/0190185	A1	7/2012	Rogers
2011/0263107	A1	10/2011	Chung et al.	2012/0196048	A1	8/2012	Ueda
2011/0265549	A1	11/2011	Cruse et al.	2012/0196450	A1	8/2012	Balseanu et al.
2011/0265715	A1	11/2011	Keller	2012/0207456	A1	8/2012	Kim et al.
2011/0265725	A1	11/2011	Tsuji	2012/0212121	A1	8/2012	Lin
2011/0265951	A1	11/2011	Xu et al.	2012/0214318	A1	8/2012	Fukazawa et al.
2011/0275018	A1	11/2011	Matteo et al.	2012/0216743	A1	8/2012	Itoh et al.
2011/0275166	A1	11/2011	Shero et al.	2012/0219824	A1	8/2012	Prolier
2011/0277690	A1	11/2011	Rozenzon et al.	2012/0220139	A1	8/2012	Lee et al.
2011/0281417	A1	11/2011	Gordon et al.	2012/0225561	A1	9/2012	Watanabe
2011/0283933	A1	11/2011	Makarov et al.	2012/0231771	A1	9/2012	Marcus
2011/0291243	A1	12/2011	Seamons	2012/0238074	A1	9/2012	Santhanam et al.
2011/0294075	A1	12/2011	Chen et al.	2012/0240858	A1	9/2012	Taniyama et al.
2011/0294288	A1	12/2011	Lee et al.	2012/0241411	A1	9/2012	Darling et al.
2011/0298062	A1	12/2011	Ganguli et al.	2012/0252229	A1	10/2012	Timans et al.
2011/0300720	A1	12/2011	Fu	2012/0263876	A1	10/2012	Haukka et al.
2011/0308453	A1	12/2011	Su et al.	2012/0264051	A1	10/2012	Angelov et al.
2011/0308460	A1	12/2011	Hong et al.	2012/0270339	A1	10/2012	Xie et al.
2011/0312191	A1	12/2011	Ohkura et al.	2012/0270393	A1	10/2012	Pore et al.
2012/0003500	A1	1/2012	Yoshida et al.	2012/0289053	A1	11/2012	Holland et al.
2012/0006489	A1	1/2012	Okita	2012/0289057	A1	11/2012	DeDontney
2012/0009802	A1	1/2012	Lavoie	2012/0295427	A1	11/2012	Bauer
2012/0024227	A1	2/2012	Takasuka et al.	2012/0304935	A1	12/2012	Oosterlaken et al.
2012/0024479	A1	2/2012	Palagashvili et al.	2012/0305026	A1	12/2012	Nomura et al.
2012/0028454	A1	2/2012	Swaminathan et al.	2012/0305196	A1	12/2012	Mori et al.
2012/0031333	A1	2/2012	Kurita et al.	2012/0305987	A1	12/2012	Hirler et al.
2012/0032311	A1	2/2012	Gates	2012/0310440	A1	12/2012	Darabnia et al.
2012/0033695	A1	2/2012	Hayashi et al.	2012/0315113	A1	12/2012	Hiroki
2012/0036732	A1	2/2012	Varadarajan	2012/0318334	A1	12/2012	Bedell et al.
2012/0040528	A1	2/2012	Kim et al.	2012/0321786	A1	12/2012	Satitpunwaycha et al.
2012/0043556	A1	2/2012	Dube et al.	2012/0322252	A1	12/2012	Son et al.
2012/0046421	A1	2/2012	Darling et al.	2012/0325148	A1	12/2012	Yamagishi et al.
2012/0052681	A1	3/2012	Marsh	2012/0328780	A1	12/2012	Yamagishi et al.
2012/0058630	A1	3/2012	Quinn	2013/0005122	A1	1/2013	Schwarzenbach et al.
2012/0064690	A1	3/2012	Hirota et al.	2013/0011983	A1	1/2013	Tsai
2012/0068242	A1	3/2012	Shin et al.	2013/0014697	A1	1/2013	Kanayama
2012/0070136	A1	3/2012	Koelmel et al.	2013/0014896	A1	1/2013	Shoji et al.
2012/0070997	A1	3/2012	Larson	2013/0019944	A1	1/2013	Hekmatshoar-Tabai et al.
2012/0074533	A1	3/2012	Aoyama	2013/0019945	A1	1/2013	Hekmatshoar-Tabai et al.
2012/0077349	A1	3/2012	Li et al.	2013/0020246	A1	1/2013	Hoots et al.
2012/0080756	A1	4/2012	Suzuki	2013/0023129	A1	1/2013	Reed
2012/0090704	A1	4/2012	Laverdiere et al.	2013/0025786	A1	1/2013	Davidkovich et al.
2012/0098107	A1	4/2012	Raisanen et al.	2013/0026451	A1	1/2013	Bangsaruntip et al.
2012/0100464	A1	4/2012	Kageyama	2013/0037858	A1	2/2013	Hong et al.
2012/0103264	A1	5/2012	Choi et al.	2013/0037886	A1	2/2013	Tsai et al.
2012/0103522	A1	5/2012	Hohenwater	2013/0048606	A1	2/2013	Mao et al.
2012/0103939	A1	5/2012	Wu et al.	2013/0052585	A1	2/2013	Ayothi et al.
2012/0107607	A1	5/2012	Takaki et al.	2013/0061755	A1	3/2013	Frederick
2012/0108039	A1	5/2012	Zajaji	2013/0064973	A1	3/2013	Chen et al.
2012/0114877	A1	5/2012	Lee	2013/0065189	A1	3/2013	Yoshii et al.
2012/0115250	A1	5/2012	Ariga et al.	2013/0068727	A1	3/2013	Okita
2012/0115257	A1	5/2012	Matsuyam et al.	2013/0068970	A1	3/2013	Matsushita
2012/0119337	A1	5/2012	Sasaki et al.	2013/0069052	A1	3/2013	Sandhu
2012/0121823	A1	5/2012	Chhabra	2013/0078392	A1	3/2013	Xiao et al.
2012/0122275	A1	5/2012	Koo et al.	2013/0081702	A1	4/2013	Mohammed et al.
2012/0122302	A1	5/2012	Weisman et al.	2013/0082274	A1	4/2013	Yang
2012/0128897	A1	5/2012	Xiao et al.	2013/0084156	A1	4/2013	Shimamoto
2012/0135145	A1	5/2012	Je et al.	2013/0084714	A1	4/2013	Oka et al.
2012/0149213	A1	6/2012	Nittala	2013/0089716	A1	4/2013	Krishnamurthy et al.
2012/0156108	A1	6/2012	Fondurulia et al.	2013/0095664	A1	4/2013	Matero et al.
2012/0156890	A1	6/2012	Yim et al.	2013/0095973	A1	4/2013	Kroneberger et al.
2012/0160172	A1	6/2012	Wamura et al.	2013/0104988	A1	5/2013	Yednak et al.
2012/0161405	A1	6/2012	Mohn	2013/0104992	A1	5/2013	Yednak et al.
2012/0164327	A1	6/2012	Sato	2013/0115383	A1	5/2013	Lu et al.
2012/0164837	A1	6/2012	Tan et al.	2013/0115763	A1	5/2013	Takamure et al.
2012/0164842	A1	6/2012	Watanabe	2013/0115768	A1	5/2013	Pore et al.
2012/0170170	A1	7/2012	Gros-Jean	2013/0119018	A1	5/2013	Kanarik et al.
2012/0171391	A1	7/2012	Won	2013/0122712	A1	5/2013	Kim et al.
2012/0171874	A1	7/2012	Thridandam et al.	2013/0126515	A1	5/2013	Shero et al.
2012/0175751	A1	7/2012	Gatineau et al.	2013/0129577	A1	5/2013	Halpin et al.
				2013/0134148	A1	5/2013	Tachikawa
				2013/0143401	A1	6/2013	Yu et al.
				2013/0157409	A1	6/2013	Vaidya
				2013/0160709	A1	6/2013	White

(56)

References Cited

U.S. PATENT DOCUMENTS

2013/0161629	A1	6/2013	Han et al.	2014/0097468	A1	4/2014	Okita
2013/0168354	A1	7/2013	Kanarik	2014/0099798	A1	4/2014	Tsuji
2013/0171818	A1	7/2013	Kim et al.	2014/0103145	A1	4/2014	White et al.
2013/0175596	A1	7/2013	Cheng et al.	2014/0106574	A1	4/2014	Kang et al.
2013/0180448	A1	7/2013	Sakaue et al.	2014/0110798	A1	4/2014	Cai
2013/0183814	A1	7/2013	Huang et al.	2014/0113457	A1	4/2014	Sims
2013/0189854	A1	7/2013	Hausmann et al.	2014/0116335	A1	5/2014	Tsuji et al.
2013/0196507	A1	8/2013	Ma et al.	2014/0117380	A1	5/2014	Loboda et al.
2013/0203266	A1	8/2013	Hintze	2014/0120487	A1	5/2014	Kaneko
2013/0209940	A1	8/2013	Sakamoto et al.	2014/0120723	A1	5/2014	Fu et al.
2013/0210241	A1	8/2013	Lavoie et al.	2014/0120738	A1	5/2014	Jung
2013/0214232	A1	8/2013	Tendulkar et al.	2014/0127907	A1	5/2014	Yang
2013/0217239	A1	8/2013	Mallick et al.	2014/0138779	A1	5/2014	Xie et al.
2013/0217240	A1	8/2013	Mallick et al.	2014/0141625	A1	5/2014	Fuzazawa et al.
2013/0217241	A1	8/2013	Underwood et al.	2014/0144500	A1	5/2014	Cao et al.
2013/0217243	A1	8/2013	Underwood et al.	2014/0158786	A1	6/2014	Santo
2013/0224964	A1	8/2013	Fukazawa	2014/0159170	A1	6/2014	Raisanen et al.
2013/0230814	A1	9/2013	Dunn et al.	2014/0167187	A1	6/2014	Kuo et al.
2013/0256265	A1	10/2013	Darling et al.	2014/0174354	A1	6/2014	Arai
2013/0256838	A1	10/2013	Sanchez et al.	2014/0175054	A1	6/2014	Carlson et al.
2013/0256962	A1	10/2013	Ranish	2014/0182053	A1	7/2014	Huang
2013/0264659	A1	10/2013	Jung	2014/0191389	A1	7/2014	Lee et al.
2013/0269612	A1	10/2013	Cheng et al.	2014/0193983	A1	7/2014	Lavoie
2013/0270676	A1	10/2013	Lindert et al.	2014/0202386	A1	7/2014	Taga
2013/0276978	A1	10/2013	Bluck et al.	2014/0202388	A1	7/2014	Um et al.
2013/0285155	A1	10/2013	Glass	2014/0209976	A1	7/2014	Yang et al.
2013/0287526	A1	10/2013	Bluck et al.	2014/0217065	A1	8/2014	Winkler et al.
2013/0288480	A1	10/2013	Sanchez et al.	2014/0220247	A1	8/2014	Haukka et al.
2013/0288485	A1	10/2013	Liang et al.	2014/0225065	A1	8/2014	Rachmady et al.
2013/0292047	A1	11/2013	Tian et al.	2014/0227072	A1	8/2014	Lee et al.
2013/0292676	A1	11/2013	Milligan et al.	2014/0227861	A1	8/2014	Wu et al.
2013/0292807	A1	11/2013	Raisanen et al.	2014/0227881	A1	8/2014	Lubomirsky et al.
2013/0295779	A1	11/2013	Chandra et al.	2014/0234550	A1	8/2014	Winter et al.
2013/0302999	A1	11/2013	Won et al.	2014/0245948	A1	9/2014	Nguyen et al.
2013/0303803	A1	11/2013	Doerr et al.	2014/0251953	A1	9/2014	Winkler et al.
2013/0313656	A1	11/2013	Tong	2014/0251954	A1	9/2014	Winkler et al.
2013/0319290	A1	12/2013	Xiao et al.	2014/0252134	A1	9/2014	Chen
2013/0320429	A1	12/2013	Thomas	2014/0252479	A1	9/2014	Utomo et al.
2013/0323435	A1	12/2013	Xiao et al.	2014/0260684	A1	9/2014	Christmann
2013/0330165	A1	12/2013	Wimplinger	2014/0264902	A1	9/2014	Ting et al.
2013/0330911	A1	12/2013	Huang et al.	2014/0272194	A1	9/2014	Xiao et al.
2013/0330933	A1	12/2013	Fukazawa et al.	2014/0273428	A1	9/2014	Shero
2013/0333619	A1	12/2013	Omari	2014/0273477	A1	9/2014	Niskanen
2013/0337583	A1	12/2013	Kobayashi et al.	2014/0273510	A1	9/2014	Chen et al.
2013/0337653	A1	12/2013	Kovalgin et al.	2014/0273528	A1	9/2014	Niskanen
2013/0340619	A1	12/2013	Tammera	2014/0273530	A1	9/2014	Nguyen
2013/0344248	A1	12/2013	Clark	2014/0273531	A1	9/2014	Niskanen
2014/0000843	A1	1/2014	Dunn et al.	2014/0283747	A1	9/2014	Kasai et al.
2014/0001520	A1	1/2014	Glass	2014/0346142	A1	11/2014	Chapuis et al.
2014/0014642	A1	1/2014	Elliot et al.	2014/0346650	A1	11/2014	Raisanen et al.
2014/0014644	A1	1/2014	Akiba et al.	2014/0349033	A1	11/2014	Nonaka et al.
2014/0015186	A1	1/2014	Wessel et al.	2014/0363980	A1	12/2014	Kawamata et al.
2014/0020619	A1	1/2014	Vincent et al.	2014/0363983	A1	12/2014	Nakano et al.
2014/0023794	A1	1/2014	Mahajani et al.	2014/0363985	A1	12/2014	Jang et al.
2014/0027884	A1	1/2014	Tang et al.	2014/0367043	A1	12/2014	Bishara et al.
2014/0033978	A1	2/2014	Adachi et al.	2014/0367642	A1	12/2014	Guo
2014/0036274	A1	2/2014	Marquardt et al.	2014/0377960	A1	12/2014	Koiwa
2014/0047705	A1	2/2014	Singh	2015/0004316	A1	1/2015	Thompson et al.
2014/0048765	A1	2/2014	Ma et al.	2015/0004317	A1	1/2015	Dussarrat et al.
2014/0056679	A1	2/2014	Yamabe et al.	2015/0004798	A1	1/2015	Chandrasekharan et al.
2014/0056770	A1	2/2014	Bedard et al.	2015/0007770	A1	1/2015	Chandrasekharan et al.
2014/0057454	A1	2/2014	Subramonium	2015/0010381	A1	1/2015	Cai
2014/0058179	A1	2/2014	Stevens et al.	2015/0014632	A1	1/2015	Kim et al.
2014/0060147	A1	3/2014	Sarin et al.	2015/0014823	A1	1/2015	Mallikajunan et al.
2014/0061770	A1	3/2014	Lee	2015/0017794	A1	1/2015	Takamure
2014/0062304	A1	3/2014	Nakano et al.	2015/0021599	A1	1/2015	Ridgeway
2014/0065841	A1	3/2014	Matero	2015/0024609	A1	1/2015	Milligan et al.
2014/0067110	A1	3/2014	Lawson et al.	2015/0041431	A1	2/2015	Zafropoulo et al.
2014/0073143	A1	3/2014	Alokozai et al.	2015/0048485	A1	2/2015	Tolle
2014/0076861	A1	3/2014	Cornelius et al.	2015/0056815	A1	2/2015	Fernandez
2014/0077240	A1	3/2014	Roucka et al.	2015/0072509	A1	3/2015	Chi et al.
2014/0084341	A1	3/2014	Weeks	2015/0078874	A1	3/2015	Sansoni
2014/0087544	A1	3/2014	Tolle	2015/0079311	A1	3/2015	Nakano
2014/0094027	A1	4/2014	Azumo et al.	2015/0086316	A1	3/2015	Greenberg
2014/0096716	A1	4/2014	Chung et al.	2015/0087154	A1	3/2015	Guha et al.
				2015/0091057	A1	4/2015	Xie et al.
				2015/0096973	A1	4/2015	Dunn et al.
				2015/0099065	A1	4/2015	Canizares et al.
				2015/0099072	A1	4/2015	Takamure et al.

(56)

References Cited

U.S. PATENT DOCUMENTS

2015/0099342	A1	4/2015	Tsai	2016/0111438	A1	4/2016	Tsutsumi et al.
2015/0102466	A1	4/2015	Colinge	2016/0115590	A1	4/2016	Haukka et al.
2015/0111374	A1	4/2015	Bao	2016/0133307	A1	5/2016	Lee et al.
2015/0111395	A1	4/2015	Hashimoto et al.	2016/0133628	A1	5/2016	Xie
2015/0122180	A1	5/2015	Chang et al.	2016/0141172	A1	5/2016	Kang
2015/0132212	A1	5/2015	Winkler et al.	2016/0145738	A1	5/2016	Liu et al.
2015/0140210	A1	5/2015	Jung et al.	2016/0148811	A1	5/2016	Nakatani et al.
2015/0147483	A1	5/2015	Fukazawa	2016/0148821	A1	5/2016	Singh
2015/0147488	A1	5/2015	Choi et al.	2016/0155629	A1	6/2016	Hawryluk et al.
2015/0147877	A1	5/2015	Jung	2016/0163556	A1	6/2016	Briggs et al.
2015/0162168	A1	6/2015	Oehrlie	2016/0163561	A1	6/2016	Hudson et al.
2015/0162185	A1	6/2015	Pore	2016/0163711	A1	6/2016	Arndt et al.
2015/0162214	A1	6/2015	Thompson	2016/0168699	A1	6/2016	Fukazawa et al.
2015/0167159	A1	6/2015	Halpin et al.	2016/0181128	A1	6/2016	Mori
2015/0170914	A1	6/2015	Haukka et al.	2016/0181368	A1	6/2016	Weeks
2015/0170947	A1	6/2015	Bluck	2016/0190137	A1	6/2016	Tsai et al.
2015/0170954	A1	6/2015	Agarwal	2016/0211135	A1	7/2016	Noda et al.
2015/0171177	A1	6/2015	Cheng et al.	2016/0211147	A1	7/2016	Fukazawa
2015/0174768	A1	6/2015	Rodnick	2016/0217857	A1	7/2016	Paudel
2015/0179501	A1	6/2015	Jhaveri et al.	2016/0225607	A1	8/2016	Yamamoto et al.
2015/0179564	A1	6/2015	Lee et al.	2016/0245704	A1	8/2016	Osaka et al.
2015/0184291	A1	7/2015	Alokozai et al.	2016/0256187	A1	9/2016	Shelton et al.
2015/0187559	A1	7/2015	Sano	2016/0268102	A1	9/2016	White
2015/0187568	A1	7/2015	Pettinger et al.	2016/0268107	A1	9/2016	White
2015/0217330	A1	8/2015	Haukka	2016/0276148	A1	9/2016	Qian et al.
2015/0217456	A1	8/2015	Tsuji et al.	2016/0284542	A1	9/2016	Noda et al.
2015/0218695	A1	8/2015	Odedra	2016/0289828	A1	10/2016	Shero et al.
2015/0225850	A1	8/2015	Arora et al.	2016/0293398	A1	10/2016	Danek et al.
2015/0228572	A1	8/2015	Yang et al.	2016/0307766	A1	10/2016	Jongbloed et al.
2015/0240359	A1	8/2015	Jdira et al.	2016/0312360	A1	10/2016	Rasheed et al.
2015/0243542	A1	8/2015	Yoshihara et al.	2016/0314964	A1	10/2016	Tang et al.
2015/0243545	A1	8/2015	Tang	2016/0334709	A1	11/2016	Huli et al.
2015/0243658	A1	8/2015	Joshi et al.	2016/0358772	A1	12/2016	Xie
2015/0255385	A1	9/2015	Lee et al.	2016/0362783	A1	12/2016	Tolle et al.
2015/0259790	A1	9/2015	Newman	2016/0362813	A1	12/2016	Bao et al.
2015/0263033	A1	9/2015	Aoyama	2016/0365280	A1	12/2016	Brink et al.
2015/0267295	A1	9/2015	Hill et al.	2016/0372365	A1	12/2016	Tang et al.
2015/0267297	A1	9/2015	Shiba	2016/0372744	A1	12/2016	Essaki et al.
2015/0267298	A1	9/2015	Saitou et al.	2016/0376700	A1	12/2016	Haukka
2015/0267299	A1	9/2015	Hawkins	2016/0376704	A1	12/2016	Raisanen
2015/0267301	A1	9/2015	Hill et al.	2016/0379851	A1	12/2016	Swaminathan et al.
2015/0270140	A1	9/2015	Gupta et al.	2016/0381732	A1	12/2016	Moench et al.
2015/0270146	A1	9/2015	Yoshihara et al.	2017/0011889	A1	1/2017	Winkler et al.
2015/0279681	A1	10/2015	Knoops	2017/0011950	A1	1/2017	Schmotzer
2015/0279708	A1	10/2015	Kobayashi et al.	2017/0018477	A1	1/2017	Kato
2015/0284848	A1	10/2015	Nakano et al.	2017/0025280	A1	1/2017	Milligan
2015/0287626	A1	10/2015	Arai	2017/0025291	A1	1/2017	Lin
2015/0287710	A1	10/2015	Yun et al.	2017/0029945	A1	2/2017	Kamakura
2015/0292088	A1	10/2015	Canizares	2017/0033004	A1	2/2017	Siew et al.
2015/0299848	A1	10/2015	Haukka et al.	2017/0037513	A1	2/2017	Haukka
2015/0308586	A1	10/2015	Shugrue et al.	2017/0040164	A1	2/2017	Wang et al.
2015/0303056	A1	11/2015	Varadarajan et al.	2017/0040206	A1	2/2017	Schmotzer et al.
2015/0315704	A1	11/2015	Nakano et al.	2017/0047446	A1	2/2017	Margetis et al.
2015/0340247	A1	11/2015	Balakrishnan et al.	2017/0051408	A1	2/2017	Kosuke et al.
2015/0340500	A1	11/2015	Brunco	2017/0053811	A1	2/2017	Fung et al.
2015/0343741	A1	12/2015	Shibata et al.	2017/0062204	A1	3/2017	Suzuki et al.
2015/0348755	A1	12/2015	Han et al.	2017/0062209	A1	3/2017	Shiba
2015/0361553	A1	12/2015	Murakawa	2017/0062258	A1	3/2017	Bluck
2015/0364371	A1	12/2015	Yen	2017/0091320	A1	3/2017	Psota et al.
2015/0367253	A1	12/2015	Kanyal et al.	2017/0092469	A1	3/2017	Kurita et al.
2015/0376211	A1	12/2015	Girard	2017/0092531	A1	3/2017	Coomer
2015/0376785	A1	12/2015	Knaapen et al.	2017/0092847	A1	3/2017	Kim et al.
2015/0380296	A1	12/2015	Antonelli et al.	2017/0100742	A1	4/2017	Pore et al.
2016/0013022	A1	1/2016	Ayoub	2017/0103907	A1	4/2017	Chu et al.
2016/0013024	A1	1/2016	Milligan et al.	2017/0107621	A1	4/2017	Suemori
2016/0020092	A1	1/2016	Kang	2017/0110313	A1	4/2017	Tang et al.
2016/0024656	A1	1/2016	White et al.	2017/0114464	A1	4/2017	Iriuda et al.
2016/0035566	A1	2/2016	LaVoie	2017/0117141	A1	4/2017	Zhu et al.
2016/0051964	A1	2/2016	Tolle et al.	2017/0117202	A1	4/2017	Tang et al.
2016/0056074	A1	2/2016	Na	2017/0117203	A1	4/2017	Tang et al.
2016/0079054	A1	3/2016	Chen et al.	2017/0117222	A1	4/2017	Kim et al.
2016/0097123	A1	4/2016	Shugrue et al.	2017/0130332	A1	5/2017	Stumpf
2016/0099150	A1	4/2016	Tsai	2017/0136578	A1	5/2017	Yoshimura
2016/0102214	A1	4/2016	Dietz et al.	2017/0154757	A1	6/2017	Winkler et al.
2016/0111272	A1	4/2016	Girard	2017/0173696	A1	6/2017	Sheinman
				2017/0178899	A1	6/2017	Kabansky et al.
				2017/0186754	A1	6/2017	Blomberg et al.
				2017/0191164	A1	7/2017	Alokozai et al.
				2017/0196562	A1	7/2017	Shelton

(56)

References Cited

U.S. PATENT DOCUMENTS

2017/0216762 A1 8/2017 Shugrue et al.
 2017/0232457 A1 8/2017 Toshiki et al.
 2017/0243734 A1 8/2017 Ishikawa et al.
 2017/0250068 A1 8/2017 Ishikawa et al.
 2017/0250075 A1 8/2017 Caymax et al.
 2017/0256429 A1 9/2017 Lawson et al.
 2017/0260649 A1 9/2017 Coomer
 2017/0263437 A1 9/2017 Li et al.
 2017/0267527 A1 9/2017 Kim et al.
 2017/0267531 A1 9/2017 Huakka
 2017/0271256 A1 9/2017 Inatsuka
 2017/0271501 A1 9/2017 Avci et al.
 2017/0278707 A1 9/2017 Margetis et al.
 2017/0287681 A1 10/2017 Nitadori et al.
 2017/0294318 A1 10/2017 Yoshida et al.
 2017/0306478 A1 10/2017 Raisanen et al.
 2017/0306479 A1 10/2017 Raisanen et al.
 2017/0306480 A1 10/2017 Zhu et al.
 2017/0316933 A1 11/2017 Xie et al.
 2017/0316940 A1 11/2017 Ishikawa
 2017/0317194 A1 11/2017 Tang et al.
 2017/0338192 A1 11/2017 Lee et al.
 2017/0342559 A1 11/2017 Fukazawa et al.
 2017/0343896 A1 11/2017 Darling et al.
 2017/0358670 A1 12/2017 Kub et al.
 2017/0372884 A1 12/2017 Margetis et al.
 2018/0010247 A1 1/2018 Niskanen
 2018/0025890 A1 1/2018 Choi
 2018/0025939 A1 1/2018 Kovalgin et al.
 2018/0033616 A1 2/2018 Masaru
 2018/0033625 A1 2/2018 Yoo
 2018/0033645 A1 2/2018 Saido et al.
 2018/0033674 A1 2/2018 Jeong
 2018/0033679 A1 2/2018 Pore
 2018/0040746 A1 2/2018 Johnson et al.
 2018/0047749 A1 2/2018 Kim
 2018/0057937 A1 3/2018 Lee et al.
 2018/0061628 A1 3/2018 Ou et al.
 2018/0061851 A1 3/2018 Ootsuka
 2018/0069019 A1 3/2018 Kim et al.
 2018/0076021 A1 3/2018 Fukushima et al.
 2018/0083435 A1 3/2018 Redler
 2018/0087152 A1 3/2018 Yoshida
 2018/0087154 A1 3/2018 Pore et al.
 2018/0087156 A1 3/2018 Kohei et al.
 2018/0102276 A1 4/2018 Zhu et al.
 2018/0105930 A1 4/2018 Kang et al.
 2018/0108587 A1 4/2018 Jiang
 2018/0114680 A1 4/2018 Kim et al.
 2018/0119283 A1 5/2018 Fukazawa
 2018/0122642 A1 5/2018 Raisanen
 2018/0122709 A1 5/2018 Xie
 2018/0122959 A1 5/2018 Calka et al.
 2018/0127876 A1 5/2018 Tolle
 2018/0130652 A1 5/2018 Pettinger et al.
 2018/0130701 A1 5/2018 Chun
 2018/0135173 A1 5/2018 Kim et al.
 2018/0135179 A1 5/2018 Toshiyuki et al.
 2018/0142353 A1 5/2018 Tetsuya et al.
 2018/0142357 A1 5/2018 Yoshikazu
 2018/0151346 A1 5/2018 Blanquart
 2018/0151358 A1 5/2018 Margetis et al.
 2018/0158688 A1 6/2018 Chen
 2018/0166258 A1 6/2018 Kim et al.
 2018/0166315 A1 6/2018 Coomer
 2018/0171475 A1 6/2018 Maes et al.
 2018/0171477 A1 6/2018 Kim et al.
 2018/0174826 A1 6/2018 Raaijmakers et al.
 2018/0182613 A1 6/2018 Blanquart et al.
 2018/0182618 A1 6/2018 Blanquart et al.
 2018/0189923 A1 7/2018 Zhong et al.
 2018/0195174 A1 7/2018 Kim et al.
 2018/0223429 A1 8/2018 Fukazawa et al.
 2018/0233372 A1 8/2018 Vayrynen et al.

2018/0286663 A1 10/2018 Kobayashi et al.
 2018/0286675 A1 10/2018 Blomberg et al.
 2018/0286711 A1 10/2018 Oosterlaken et al.

FOREIGN PATENT DOCUMENTS

CN 1664987 9/2005
 CN 1714168 12/2005
 CN 1825535 8/2006
 CN 101330015 12/2008
 CN 101515563 8/2009
 CN 101522943 9/2009
 CN 101681873 3/2010
 CN 101423937 9/2011
 CN 102383106 3/2012
 DE 102008052750 6/2009
 EP 0887632 12/1998
 EP 1889817 2/2008
 EP 2036600 3/2009
 EP 2426233 7/2012
 FR 1408266 8/1965
 FR 2233614 1/1975
 GB 752-277 7/1956
 JP 58-19462 4/1983
 JP 59-211779 11/1984
 JP 61038863 2/1986
 JP H01296613 11/1989
 JP H0293071 4/1990
 JP H02-185038 7/1990
 JP 2845163 1/1991
 JP 03-044472 2/1991
 JP H03-155625 7/1991
 JP H03-248427 11/1991
 JP H04029313 1/1992
 JP H04115531 4/1992
 JP H05-023079 3/1993
 JP H05-118928 5/1993
 JP 05171446 7/1993
 JP 06-053210 2/1994
 JP H06-052210 2/1994
 JP H0684888 3/1994
 JP H06-338497 12/1994
 JP H0729836 1/1995
 JP H07297271 1/1995
 JP H07-109576 4/1995
 JP 07-130731 5/1995
 JP 07-034936 8/1995
 JP H07-034936 8/1995
 JP 7-272694 10/1995
 JP H07283149 10/1995
 JP H07-209093 11/1995
 JP 08-181135 7/1996
 JP H08181135 7/1996
 JP H08335558 12/1996
 JP 9-89676 4/1997
 JP H09148322 6/1997
 JP H10041096 2/1998
 JP 10-064696 3/1998
 JP H10-153494 6/1998
 JP H10-227793 8/1998
 JP 10-0261620 9/1998
 JP 11097163 4/1999
 JP H11-118615 4/1999
 JP H11-183264 7/1999
 JP H11-183265 7/1999
 JP H11-195688 7/1999
 JP H11-287715 10/1999
 JP 2001023872 1/2001
 JP 2001207265 7/2001
 JP 2001207268 7/2001
 JP 2001210602 8/2001
 JP 2001220677 8/2001
 JP 2001342570 12/2001
 JP 2002164342 6/2002
 JP 2002170781 6/2002
 JP 2003035574 2/2003
 JP 2003133300 5/2003
 JP 2003153706 5/2003
 JP 2003303814 10/2003

(56)

References Cited

FOREIGN PATENT DOCUMENTS

JP	2004014952	1/2004	WO	1999023690	5/1999
JP	2004023043	1/2004	WO	DM/048579	7/1999
JP	2004091848	3/2004	WO	2004008491	7/2002
JP	2004113270	4/2004	WO	2004008827	1/2004
JP	2004128019	4/2004	WO	2004010467	1/2004
JP	2004134553	4/2004	WO	2004106584	12/2004
JP	2004294638	10/2004	WO	2005112082	11/2005
JP	2004310019	11/2004	WO	2006054854	5/2006
JP	2004538374	12/2004	WO	2006056091	6/2006
JP	2005033221	2/2005	WO	2006078666	7/2006
JP	2005079254	3/2005	WO	2006080782	8/2006
JP	2005507030	3/2005	WO	2006101857	9/2006
JP	2005172489	6/2005	WO	2006114781	11/2006
JP	2006059931	3/2006	WO	2007024720	3/2007
JP	2006090762	4/2006	WO	2007027165	3/2007
JP	2006153706	6/2006	WO	2007117718	10/2007
JP	2006186271	7/2006	WO	2007140376	12/2007
JP	2006188729	7/2006	WO	2008045972	4/2008
JP	2006278058	10/2006	WO	2008091900	7/2008
JP	2006319261	11/2006	WO	2008121463	10/2008
JP	2007027777	2/2007	WO	2008147731	12/2008
JP	3140111	3/2008	WO	2009028619	3/2009
JP	2008060304	3/2008	WO	2009039251	3/2009
JP	2008066159	3/2008	WO	2009099776	8/2009
JP	2008172083	7/2008	WO	2009154889	12/2009
JP	2008527748	7/2008	WO	2009154896	12/2009
JP	2008202107	9/2008	WO	2010039363	4/2010
JP	2009016815	1/2009	WO	2010077533	7/2010
JP	2009088421	4/2009	WO	2010100702	9/2010
JP	2009239082	4/2009	WO	2010129428	11/2010
JP	2009099938	5/2009	WO	2010129430	11/2010
JP	2009194248	8/2009	WO	2010129431	11/2010
JP	2009251216	10/2009	WO	2010118051	1/2011
JP	2010067940	3/2010	WO	2011019950	2/2011
JP	2010097834	4/2010	WO	2011149640	12/2011
JP	2010205967	9/2010	WO	2012077590	6/2012
JP	2010251444	10/2010	WO	2013078065	5/2013
JP	2011049592	3/2011	WO	2013078066	5/2013
JP	2011162830	8/2011	WO	2014107290	7/2014
JP	2011181681	9/2011	WO	2015026230	2/2015
JP	2012089837	5/2012	WO	2015107009	7/2015
JP	2012146939	8/2012	WO	2018109553	6/2016
JP	2013026479	2/2013	WO	2018109554	6/2016
JP	2013235912	11/2013	WO	2017108713	6/2017
JP	2014522104	8/2014	WO	2017108714	6/2017
JP	2016174158	9/2016	WO	2017212546	12/2017
KR	10-2000-0031098	6/2000	WO	2018003072	1/2018
KR	10-2000-0045257	7/2000	WO	2018008088	1/2018
KR	10-0295043	4/2001	WO	2018020316	2/2018
KR	10-2002-0064028	8/2002	WO	2018020318	2/2018
KR	2002-0086763	11/2002	WO	2018020320	2/2018
KR	10-0377095	3/2003	WO	2018020327	2/2018
KR	2003-0092305	12/2003	WO	2008045972	4/2018
KR	10-2005-0054122	6/2005	WO	2018109551	6/2018
KR	10-0547248	1/2006	WO	2018109552	6/2018
KR	10-0593960	6/2006			
KR	10-0688484	2/2007			
KR	10-2007-0084683	8/2007			
KR	10-2009-0055443	6/2009			
KR	10-20100020834	2/2010			
KR	10-20100032812	3/2010			
KR	10-1114219	2/2012			
KR	10-1114219	3/2012			
KR	10-1535573	7/2015			
KR	10-20180054366	5/2018			
TW	538327	6/2003			
TW	I226380	1/2005			
TW	M292692	6/2006			
TW	200701301	1/2007			
TW	200731357	8/2007			
TW	201247690	12/2012			
TW	201330086	7/2013			
WO	W1996017107	6/1996			
WO	1997003223	1/1997			
WO	1998032893	7/1998			

OTHER PUBLICATIONS

USPTO; Office Action dated Feb. 15, 2011 in U.S. Appl. No. 12/118,596.

USPTO; Notice of Allowance dated Aug. 4, 2011 in U.S. Appl. No. 12/118,596.

USPTO; Non-Final Office Action dated Apr. 1, 2010 in U.S. Appl. No. 12/357,174.

USPTO; Final Office Action dated Sep. 1, 2010 in U.S. Appl. No. 12/357,174.

USPTO; Notice of Allowance dated Dec. 13, 2010 in U.S. Appl. No. 12/357,174.

USPTO; Non-Final Office Action dated Dec. 29, 2010 in U.S. Appl. No. 12/362,023.

USPTO; Non-Final Office Action dated Jul. 26, 2011 in U.S. Appl. No. 12/416,809.

USPTO; Final Office Action dated Dec. 6, 2011 in U.S. Appl. No. 12/416,809.

USPTO; Notice of Allowance dated Jun. 16, 2011 in U.S. Appl. No. 12/430,751.

(56)

References Cited

OTHER PUBLICATIONS

USPTO; Notice of Allowance dated Jul. 27, 2011 in U.S. Appl. No. 12/730,751.
USPTO; Notice of Allowance dated Oct. 1, 2010 in U.S. Appl. No. 12/467,017.
USPTO; Non-Final Office Action dated Mar. 18, 2010 in U.S. Appl. No. 12/489,252.
USPTO; Notice of Allowance dated Sep. 2, 2010 in U.S. Appl. No. 12/489,252.
USPTO; Non-Final Office Action dated Dec. 15, 2010 in U.S. Appl. No. 12/553,759.
USPTO; Final Office Action dated May 4, 2011 in U.S. Appl. No. 12/553,759.
USPTO; Non-Final Office Action dated Sep. 6, 2011 in U.S. Appl. No. 12/553,759.
USPTO; Notice of Allowance dated Jan. 24, 2012 in U.S. Appl. No. 12/553,759.
USPTO; Non-Final Office Action dated Oct. 19, 2012 in U.S. Appl. No. 12/618,355.
USPTO; Final Office Action dated May 8, 2013 in U.S. Appl. No. 12/618,355.
USPTO; Non-Final Office Action dated Apr. 8, 2015 in U.S. Appl. No. 12/618,355.
USPTO; Final Office Action dated Oct. 22, 2015 in U.S. Appl. No. 12/618,355.
USPTO; Non-Final Office Action dated Jun. 30, 2016 in U.S. Appl. No. 12/618,355.
USPTO; Final Office Action dated Feb. 10, 2017 in U.S. Appl. No. 12/618,355.
USPTO; Non-Final Office Action dated Nov. 29, 2017 in U.S. Appl. No. 12/618,355.
USPTO; Non-Final Office Action dated Feb. 16, 2012 in U.S. Appl. No. 12/618,419.
USPTO; Final Office Action dated Jun. 22, 2012 in U.S. Appl. No. 12/618,419.
USPTO; Non-Final Office Action dated Jun. 27, 2012 in U.S. Appl. No. 12/618,419.
USPTO; Notice of Allowance dated Apr. 12, 2013 in U.S. Appl. No. 12/618,419.
USPTO; Non-Final Office Action dated Dec. 6, 2011 in U.S. Appl. No. 12/718,731.
USPTO; Notice of Allowance dated Mar. 16, 2012 in U.S. Appl. No. 12/718,731.
USPTO; Restriction Requirement dated Jan. 15, 2013 in U.S. Appl. No. 12/754,223.
USPTO; Office Action dated Feb. 26, 2013 in U.S. Appl. No. 12/754,223.
USPTO; Final Office Action dated Jun. 28, 2013 in U.S. Appl. No. 12/754,223.
USPTO; Office Action dated Feb. 25, 2014 in U.S. Appl. No. 12/754,223.
USPTO; Final Office Action dated Jul. 14, 2014 in U.S. Appl. No. 12/754,223.
USPTO; Non-Final Office Action dated Mar. 25, 2015 in U.S. Appl. No. 12/754,223.
USPTO; Final Office Action dated Aug. 12, 2015 in U.S. Appl. No. 12/754,223.
USPTO; Notice of Allowance dated May 23, 2016 in U.S. Appl. No. 12/754,223.
USPTO; Office Action dated Apr. 23, 2013 in U.S. Appl. No. 12/763,037.
USPTO; Final Office Action dated Oct. 21, 2013 in U.S. Appl. No. 12/763,037.
USPTO; Office Action dated Oct. 8, 2014 in U.S. Appl. No. 12/763,037.
USPTO; Notice of Allowance dated Jan. 27, 2015 in U.S. Appl. No. 12/763,037.
USPTO; Non-Final Office Action dated Jan. 24, 2011 in U.S. Appl. No. 12/778,808.

USPTO; Notice of Allowance dated May 9, 2011 in U.S. Appl. No. 12/778,808.
USPTO; Notice of Allowance dated Oct. 12, 2012 in U.S. Appl. No. 12/832,739.
USPTO; Non-Final Office Action dated Oct. 16, 2012 in U.S. Appl. No. 12/847,848.
USPTO; Final Office Action dated Apr. 22, 2013 in U.S. Appl. No. 12/847,848.
USPTO; Notice of Allowance dated Jan. 16, 2014 in U.S. Appl. No. 12/847,848.
USPTO; Restriction Requirement dated Sep. 25, 2012 in U.S. Appl. No. 12/854,818.
USPTO; Office Action dated Dec. 6, 2012 in U.S. Appl. No. 12/854,818.
USPTO; Final Office Action dated Mar. 13, 2013 in U.S. Appl. No. 12/854,818.
USPTO; Office Action dated Aug. 30, 2013 in U.S. Appl. No. 12/854,818.
USPTO; Final Office Action dated Mar. 26, 2014 in U.S. Appl. No. 12/854,818.
USPTO; Office Action dated Jun. 3, 2014 in U.S. Appl. No. 12/854,818.
USPTO; Non-Final Office Action dated Jul. 11, 2012 in U.S. Appl. No. 12/875,889.
USPTO; Notice of Allowance dated Jan. 4, 2013 in U.S. Appl. No. 12/875,889.
USPTO; Notice of Allowance dated Jan. 9, 2012 in U.S. Appl. No. 12/901,323.
USPTO; Non-Final Office Action dated Nov. 20, 2013 in U.S. Appl. No. 12/910,607.
USPTO; Final Office Action dated Apr. 28, 2014 in U.S. Appl. No. 12/910,607.
USPTO; Notice of Allowance dated Aug. 15, 2014 in U.S. Appl. No. 12/910,607.
USPTO; Non-Final Office Action dated Oct. 24, 2012 in U.S. Appl. No. 12/940,906.
USPTO; Final Office Action dated Feb. 13, 2013 in U.S. Appl. No. 12/940,906.
USPTO; Notice of Allowance dated Apr. 23, 2013 in U.S. Appl. No. 12/940,906.
USPTO; Non-Final Office Action dated Dec. 7, 2012 in U.S. Appl. No. 12/953,870.
USPTO; Final Office Action dated Apr. 22, 2013 in U.S. Appl. No. 12/953,870.
USPTO; Non-Final Office Action dated Sep. 19, 2012 in U.S. Appl. No. 13/016,735.
USPTO; Final Office Action dated Feb. 11, 2013 in U.S. Appl. No. 13/016,735.
USPTO; Notice of Allowance dated Apr. 24, 2013 in U.S. Appl. No. 13/016,735.
USPTO; Non-Final Office Action dated Apr. 4, 2012 in U.S. Appl. No. 13/030,438.
USPTO; Final Office Action dated Aug. 22, 2012 in U.S. Appl. No. 13/030,438.
USPTO; Notice of Allowance dated Oct. 24, 2012 in U.S. Appl. No. 13/030,438.
USPTO; Non-Final Office Action dated Dec. 3, 2012 in U.S. Appl. No. 13/040,013.
USPTO; Notice of Allowance dated May 3, 2013 in U.S. Appl. No. 13/040,013.
USPTO; Notice of Allowance dated Sep. 13, 2012 in U.S. Appl. No. 13/085,698.
USPTO; Non-Final Office Action dated Mar. 29, 2013 in U.S. Appl. No. 13/094,402.
USPTO; Final Office Action dated Jul. 17, 2013 in U.S. Appl. No. 13/094,402.
USPTO; Notice of Allowance dated Sep. 30, 2013 in U.S. Appl. No. 13/094,402.
USPTO; Restriction Requirement dated May 8, 2013 in U.S. Appl. No. 13/102,980.
USPTO; Office Action dated Oct. 7, 2013 in U.S. Appl. No. 13/102,980.

(56)

References Cited

OTHER PUBLICATIONS

USPTO; Final Office Action dated Mar. 25, 2014 in U.S. Appl. No. 13/102,980.
USPTO; Notice of Allowance dated Jul. 3, 2014 in U.S. Appl. No. 13/102,980.
USPTO; Non-Final Office Action dated Jul. 17, 2014 in U.S. Appl. No. 13/154,271.
USPTO; Final Office Action dated Jan. 2, 2015 in U.S. Appl. No. 13/154,271.
USPTO; Non-Final Office Action dated May 27, 2015 in U.S. Appl. No. 13/154,271.
USPTO; Final Office Action dated Nov. 23, 2015 in U.S. Appl. No. 13/154,271.
USPTO; Notice of Allowance dated Feb. 10, 2016 in U.S. Appl. No. 13/154,271.
USPTO; Non-Final Office Action dated Jun. 27, 2016 in U.S. Appl. No. 13/166,367.
USPTO; Final Office Action dated Dec. 30, 2016 in U.S. Appl. No. 13/166,367.
USPTO; Non-Final Office Action dated Oct. 27, 2014 in U.S. Appl. No. 13/169,951.
USPTO; Final Office Action dated May 26, 2015 in U.S. Appl. No. 13/169,951.
USPTO; Non-Final Office Action dated Sep. 1, 2015 in U.S. Appl. No. 13/169,951.
USPTO; Final Office Action dated Mar. 3, 2016 in U.S. Appl. No. 13/169,951.
USPTO; Non-Final Office Action dated Jun. 9, 2016 in U.S. Appl. No. 13/169,951.
USPTO; Final Office Action dated Dec. 9, 2016 in U.S. Appl. No. 13/169,951.
USPTO; Non-Final Office Action dated Apr. 26, 2017 in U.S. Appl. No. 13/169,951.
USPTO; Final Office Action dated Nov. 2, 2017 in U.S. Appl. No. 13/169,951.
USPTO; Non-Final Office Action dated Apr. 6, 2018 in U.S. Appl. No. 13/169,951.
USPTO; Non-Final Office Action dated Jun. 24, 2014 in U.S. Appl. No. 13/181,407.
USPTO; Final Office Action dated Sep. 24, 2014 in U.S. Appl. No. 13/181,407.
USPTO; Non-Final Office Action dated Jan. 2, 2015 in U.S. Appl. No. 13/181,407.
USPTO; Final Office Action dated Apr. 8, 2015 in U.S. Appl. No. 13/181,407.
USPTO; Non-Final Office Action dated Jan. 23, 2013 in U.S. Appl. No. 13/184,351.
USPTO; Final Office Action dated Jul. 29, 2013 in U.S. Appl. No. 13/184,351.
USPTO; Non-Final Office Action dated Jul. 16, 2014 in U.S. Appl. No. 13/184,351.
USPTO; Final Office Action dated Feb. 17, 2015 in U.S. Appl. No. 13/184,351.
USPTO; Non-Final Office Action dated Aug. 10, 2015 in U.S. Appl. No. 13/184,351.
USPTO; Final Office Action dated Feb. 12, 2016 in U.S. Appl. No. 13/184,351.
USPTO; Non-Final Office Action dated Dec. 15, 2016 in U.S. Appl. No. 13/184,351.
USPTO; Final Office Action dated Jun. 15, 2017 in U.S. Appl. No. 13/184,351.
USPTO; Non-Final Office Action dated Sep. 17, 2014 in U.S. Appl. No. 13/187,300.
USPTO; Final Office Action dated Apr. 15, 2015 in U.S. Appl. No. 13/187,300.
USPTO; Non-Final Office Action dated Apr. 7, 2016 in U.S. Appl. No. 13/187,300.
USPTO; Final Office Acton dated Sep. 23, 2016 in U.S. Appl. No. 13/187,300.

USPTO; Non-Final Office Action dated Jan. 30, 2017 in U.S. Appl. No. 13/187,300.
USPTO; Final Office Action dated Aug. 9, 2017 in U.S. Appl. No. 13/187,300.
USPTO; Non-Final Office Action dated Oct. 1, 2012 in U.S. Appl. No. 13/191,762.
USPTO; Final Office Action dated Apr. 10, 2013 in U.S. Appl. No. 13/191,762.
USPTO; Notice of Allowance dated Aug. 15, 2013 in U.S. Appl. No. 13/191,762.
USPTO; Non-Final Office Action dated Oct. 22, 2012 in U.S. Appl. No. 13/238,960.
USPTO; Final Office Action dated May 3, 2013 in U.S. Appl. No. 13/238,960.
USPTO; Non-Final Office Action dated Apr. 26, 2013 in U.S. Appl. No. 13/250,721.
USPTO; Notice of Allowance dated Sep. 11, 2013 in U.S. Appl. No. 13/250,721.
USPTO; Non-Final Office Action dated Jul. 2, 2014 in U.S. Appl. No. 13/283,408.
USPTO; Final Office Action dated Jan. 29, 2015 in U.S. Appl. No. 13/283,408.
USPTO; Non-Final Office Action dated Jun. 17, 2015 in U.S. Appl. No. 13/283,408.
USPTO; Final Office Action dated Dec. 18, 2015 in U.S. Appl. No. 13/283,408.
USPTO; Notice of Allowance dated Mar. 28, 2016 in U.S. Appl. No. 13/283,408.
USPTO; Restriction Requirement dated Dec. 16, 2013 in U.S. Appl. No. 13/284,642.
USPTO; Restriction Requirement dated Apr. 21, 2014 in U.S. Appl. No. 13/284,642.
USPTO; Office Action dated Jul. 30, 2014 in U.S. Appl. No. 13/284,642.
USPTO; Notice of Allowance dated Feb. 11, 2015 in U.S. Appl. No. 13/284,642.
USPTO; Office Action dated Jan. 28, 2014 in U.S. Appl. No. 13/312,591.
USPTO; Final Office Action dated May 14, 2014 in U.S. Appl. No. 13/312,591.
USPTO; Non-Final Office Action dated Nov. 26, 2014 in U.S. Appl. No. 13/312,591.
USPTO; Final Office Action dated Mar. 20, 2015 in U.S. Appl. No. 13/312,591.
USPTO; Notice of Allowance dated May 14, 2015 in U.S. Appl. No. 13/312,591.
USPTO; Non-Final Office Action dated Apr. 9, 2014 in U.S. Appl. No. 13/333,420.
USPTO; Notice of Allowance dated Sep. 15, 2014 in U.S. Appl. No. 13/333,420.
USPTO; Office Action dated Jan. 10, 2013 in U.S. Appl. No. 13/339,609.
USPTO; Office Action dated Feb. 11, 2013 in U.S. Appl. No. 13/339,609.
USPTO; Final Office Action dated May 17, 2013 in U.S. Appl. No. 13/339,609.
USPTO; Office Action dated Aug. 29, 2013 in U.S. Appl. No. 13/339,609.
USPTO; Final Office Action dated Dec. 18, 2013 in U.S. Appl. No. 13/339,609.
USPTO; Notice of Allowance dated Apr. 7, 2014 in U.S. Appl. No. 13/339,609.
USPTO; Non-Final Office Action dated Oct. 10, 2012 in U.S. Appl. No. 13/406,791.
USPTO; Final Office Action dated Jan. 31, 2013 in U.S. Appl. No. 13/406,791.
USPTO; Non-Final Office Action dated Apr. 25, 2013 in U.S. Appl. No. 13/406,791.
USPTO; Final Office Action dated Aug. 23, 2013 in U.S. Appl. No. 13/406,791.
USPTO; Non-Final Office Action dated Dec. 4, 2013 in U.S. Appl. No. 13/406,791.

(56)

References Cited

OTHER PUBLICATIONS

USPTO; Final Office Action dated Apr. 21, 2014 in U.S. Appl. No. 13/406,791.
USPTO; Non-Final Office Action dated Jan. 14, 2013 in U.S. Appl. No. 13/410,970.
USPTO; Notice of Allowance dated Feb. 14, 2013 in U.S. Appl. No. 13/410,970.
USPTO; Non-Final Office Action dated Feb. 13, 2014 in U.S. Appl. No. 13/411,271.
USPTO; Non-Final Office Action dated Jul. 31, 2014 in U.S. Appl. No. 13/411,271.
USPTO; Final Office Action dated Jan. 16, 2015 in U.S. Appl. No. 13/411,271.
USPTO; Notice of Allowance dated Oct. 6, 2015 in U.S. Appl. No. 13/411,271.
USPTO; Restriction Requirement dated Oct. 29, 2013 in U.S. Appl. No. 13/439,528.
USPTO; Office Action dated Feb. 4, 2014 in U.S. Appl. No. 13/439,528.
USPTO; Final Office Action dated Jul. 8, 2014 in U.S. Appl. No. 13/439,528.
USPTO; Notice of Allowance dated Oct. 21, 2014 in U.S. Appl. No. 13/439,528.
USPTO; Non-Final Office Action dated Apr. 11, 2013 in U.S. Appl. No. 13/450,368.
USPTO; Notice of Allowance dated Jul. 17, 2013 in U.S. Appl. No. 13/450,368.
USPTO; Office Action dated May 23, 2013 in U.S. Appl. No. 13/465,340.
USPTO; Final Office Action dated Oct. 30, 2013 in U.S. Appl. No. 13/465,340.
USPTO; Notice of Allowance dated Feb. 12, 2014 in U.S. Appl. No. 13/465,340.
USPTO; Non-Final Office Action dated Oct. 17, 2013 in U.S. Appl. No. 13/493,897.
USPTO; Notice of Allowance dated Mar. 20, 2014 in U.S. Appl. No. 13/493,897.
USPTO; Office Action dated Dec. 20, 2013 in U.S. Appl. No. 13/535,214.
USPTO; Final Office Action dated Jun. 18, 2014 in U.S. Appl. No. 13/535,214.
USPTO; Notice of Allowance dated Oct. 23, 2014 in U.S. Appl. No. 13/535,214.
USPTO; Non-Final Office Action dated Sep. 11, 2013 in U.S. Appl. No. 13/550,419.
USPTO; Final Office Action dated Jan. 27, 2014 in U.S. Appl. No. 13/550,419.
USPTO; Notice of Allowance dated May 29, 2014 in U.S. Appl. No. 13/550,419.
USPTO; Non-Final Office Action dated Aug. 8, 2014 in U.S. Appl. No. 13/563,066.
USPTO; Final Office Action dated Feb. 12, 2015 in U.S. Appl. No. 13/563,066.
USPTO; Notice of Allowance dated Jun. 12, 2015 in U.S. Appl. No. 13/563,066.
USPTO; Notice of Allowance dated Jul. 16, 2015 in U.S. Appl. No. 13/563,066.
USPTO; Non-Final Office Action dated Nov. 7, 2013 in U.S. Appl. No. 13/565,564.
USPTO; Final Office Action dated Feb. 28, 2014 in U.S. Appl. No. 13/565,564.
USPTO; Non-Final Office Action dated Jul. 2, 2014 in U.S. Appl. No. 13/565,564.
USPTO; Notice of Allowance dated Nov. 3, 2014 in U.S. Appl. No. 13/565,564.
USPTO; Non-Final Office Action dated Aug. 30, 2013 in U.S. Appl. No. 13/570,067.
USPTO; Notice of Allowance dated Jan. 6, 2014 in U.S. Appl. No. 13/570,067.

USPTO; Non-Final Office Action dated Oct. 15, 2014 in U.S. Appl. No. 13/597,043.
USPTO; Final Office Action dated Mar. 13, 2015 in U.S. Appl. No. 13/597,043.
USPTO;; Notice of Allowance dated Aug. 28, 2015 in U.S. Appl. No. 13/597,043.
USPTO; Non-Final Office Action dated Feb. 12, 2015 in U.S. Appl. No. 13/597,108.
USPTO; Final Office Action dated Jun. 1, 2015 in U.S. Appl. No. 13/597,108.
USPTO; Non-Final Office Action dated Dec. 8, 2015 in U.S. Appl. No. 13/597,108.
USPTO; Final Office Action dated Jun. 2, 2016 in U.S. Appl. No. 13/597,108.
USPTO; Non-Final Office Action dated Sep. 15, 2016 in U.S. Appl. No. 13/597,108.
USPTO; Notice of Allowance dated Mar. 27, 2014 in U.S. Appl. No. 13/604,498.
USPTO; Office Action dated Nov. 15, 2013 in U.S. Appl. No. 13/612,538.
USPTO; Office Action dated Jul. 10, 2014 in U.S. Appl. No. 13/612,538.
USPTO; Non-Final Office Action dated Apr. 15, 2015 in U.S. Appl. No. 13/646,403.
USPTO; Final Office Action dated Oct. 15, 2015 in U.S. Appl. No. 13/646,403.
USPTO; Notice of Allowance dated Feb. 2, 2016 in U.S. Appl. No. 13/646,403.
USPTO; Non-Final Office Action dated May 15, 2014 in U.S. Appl. No. 13/646,471.
USPTO; Final Office Action dated Aug. 18, 2014 in U.S. Appl. No. 13/646,471.
USPTO; Non-Final Office Action dated Dec. 16, 2014 in U.S. Appl. No. 13/646,471.
USPTO; Final Office Action dated Apr. 21, 2015 in U.S. Appl. No. 13/646,471.
USPTO; Non-Final Office Action dated Aug. 19, 2015 in U.S. Appl. No. 13/646,471.
USPTO; Final Office Action dated Jan. 22, 2016 in U.S. Appl. No. 13/646,471.
USPTO; Non-Final Office Action dated Jun. 2, 2016 in U.S. Appl. No. 13/646,471.
USPTO; Non-Final Office Action dated May 28, 2015 in U.S. Appl. No. 13/651,144.
USPTO; Final Office Action dated Dec. 14, 2017 in U.S. Appl. No. 13/651,144.
USPTO; Final Office Action dated Sep. 30, 2016 in Application No. 14/808,979.
USPTO; Final Office Action dated Nov. 19, 2015 in U.S. Appl. No. 13/651,144.
USPTO; Non-Final Office Action dated May 10, 2016 in U.S. Appl. No. 13/651,144.
USPTO; Final Office Action dated Sep. 20, 2016 in U.S. Appl. No. 13/651,144.
USPTO; Non-Final Office Action dated May 17, 2017 in U.S. Appl. No. 13/651,144.
USPTO; Non-Final Office Action dated Dec. 14, 2017 in U.S. Appl. No. 13/651,144.
USPTO; Non-Final Office Action dated Nov. 19, 2015 in U.S. Appl. No. 14/659,437.
USPTO; Final Office Action dated Mar. 17, 2016 in U.S. Appl. No. 14/659,437.
USPTO; Notice of Allowance dated May 31, 2016 in U.S. Appl. No. 14/659,437.
USPTO; Non-Final Office Action dated Jun. 18, 2015 in U.S. Appl. No. 13/665,366.
USPTO; Non-Final Office Action dated Apr. 3, 2015 in U.S. Appl. No. 13/677,133.
USPTO; Notice of Allowance dated Aug. 4, 2015 in U.S. Appl. No. 13/677,133.
USPTO; Office Action dated Jun. 2, 2014 in U.S. Appl. No. 13/677,151.

(56)

References Cited

OTHER PUBLICATIONS

- USPTO; Final Office Action dated Nov. 14, 2014 in U.S. Appl. No. 13/677,151.
- USPTO; Notice of Allowance dated Feb. 26, 2015 in U.S. Appl. No. 13/677,151.
- USPTO; Non-Final Office Action dated Aug. 20, 2013 in U.S. Appl. No. 13/679,502.
- USPTO; Final Office Action dated Feb. 25, 2014 in U.S. Appl. No. 13/679,502.
- USPTO; Notice of Allowance dated May 2, 2014 in U.S. Appl. No. 13/679,502.
- USPTO; Non-Final Office Action dated Jul. 21, 2015 in U.S. Appl. No. 13/727,324.
- USPTO; Final Office Action dated Jan. 22, 2016 in U.S. Appl. No. 13/727,324.
- USPTO; Non-Final Office Action dated May 25, 2016 in U.S. Appl. No. 13/727,324.
- USPTO; Final Office Action dated Dec. 1, 2016 in U.S. Appl. No. 13/727,324.
- USPTO; Notice of Allowance dated Mar. 1, 2017 in U.S. Appl. No. 13/727,324.
- USPTO; Non-Final Office Action dated Oct. 24, 2013 in U.S. Appl. No. 13/749,878.
- USPTO; Non-Final Office Action dated Jun. 18, 2014 in U.S. Appl. No. 13/749,878.
- USPTO; Final Office Action dated Dec. 10, 2014 in U.S. Appl. No. 13/749,878.
- USPTO; Notice of Allowance Mar. 13, 2015 dated in U.S. Appl. No. 13/749,878.
- USPTO; Office Action dated Apr. 23, 2014 in U.S. Appl. No. 13/784,362.
- USPTO; Notice of Allowance dated Aug. 13, 2014 in U.S. Appl. No. 13/784,362.
- USPTO; Non-Final Office Action dated Dec. 19, 2013 in U.S. Appl. No. 13/784,388.
- USPTO; Notice of Allowance dated Jun. 4, 2014 in U.S. Appl. No. 13/784,388.
- USPTO; Restriction Requirement dated May 8, 2014 in U.S. Appl. No. 13/791,246.
- USPTO; Non-Final Office Action dated Sep. 19, 2014 in U.S. Appl. No. 13/791,246.
- USPTO; Final Office Action dated Mar. 25, 2015 in U.S. Appl. No. 13/791,246.
- USPTO; Non-Final Office Action dated Oct. 26, 2015 in U.S. Appl. No. 13/791,246.
- USPTO; Final Office Action dated Apr. 20, 2016 in U.S. Appl. No. 13/791,246.
- USPTO; Non-Final Office Action dated Aug. 11, 2016 in U.S. Appl. No. 13/791,246.
- USPTO; Notice of Allowance dated Nov. 25, 2016 in U.S. Appl. No. 13/791,246.
- USPTO; Non-Final Office Action dated Nov. 6, 2015 in U.S. Appl. No. 13/791,339.
- USPTO; Final Office Action dated Apr. 12, 2016 in U.S. Appl. No. 13/791,339.
- USPTO; Notice of Allowance dated Aug. 24, 2016 in U.S. Appl. No. 13/791,339.
- USPTO; Non-Final Office Action dated Mar. 21, 2014 in U.S. Appl. No. 13/799,708.
- USPTO; Notice of Allowance dated Oct. 31, 2014 in U.S. Appl. No. 13/799,708.
- USPTO; Non-Final Office Action dated Sep. 1, 2016 in U.S. Appl. No. 14/827,177.
- USPTO; Restriction Requirement dated Jun. 26, 2014 in U.S. Appl. No. 13/874,708.
- USPTO; Non-Final Office Action dated Oct. 9, 2014 in U.S. Appl. No. 13/874,708.
- USPTO; Notice of Allowance dated Mar. 10, 2015 in U.S. Appl. No. 13/874,708.
- USPTO; Notice of Allowance dated Apr. 10, 2014 in U.S. Appl. No. 13/901,341.
- USPTO; Notice of Allowance dated Jun. 6, 2014 in U.S. Appl. No. 13/901,341.
- USPTO; Non-Final Office Action dated Jan. 2, 2015 in U.S. Appl. No. 13/901,372.
- USPTO; Final Office Action dated Apr. 16, 2015 in U.S. Appl. No. 13/901,372.
- USPTO; Non-Final Office Action dated Jul. 8, 2015 in U.S. Appl. No. 13/901,400.
- USPTO; Final Office Action dated Jan. 14, 2016 in U.S. Appl. No. 13/901,400.
- USPTO; Notice of Allowance dated Apr. 12, 2016 in U.S. Appl. No. 13/901,400.
- USPTO; Notice of Allowance dated Aug. 5, 2015 in U.S. Appl. No. 13/901,372.
- USPTO; Non-Final Office Action dated Apr. 24, 2014 in U.S. Appl. No. 13/912,666.
- USPTO; Final Office Action dated Sep. 25, 2014 in U.S. Appl. No. 13/912,666.
- USPTO; Non-Final Office Action dated Jan. 26, 2015 in U.S. Appl. No. 13/912,666.
- USPTO; Notice of Allowance dated Jun. 25, 2015 in U.S. Appl. No. 13/912,666.
- USPTO; Non-Final Office Action dated Dec. 16, 2014 in U.S. Appl. No. 13/915,732.
- USPTO; Final Office Action dated Apr. 10, 2015 in U.S. Appl. No. 13/915,732.
- USPTO; Notice of Allowance dated Jun. 19, 2015 in U.S. Appl. No. 13/915,732.
- USPTO; Notice of Allowance dated Mar. 17, 2015 in U.S. Appl. No. 13/923,197.
- USPTO; Non-Final Office Action dated Sep. 12, 2014 in U.S. Appl. No. 13/941,134.
- USPTO; Notice of Allowance dated Jan. 20, 2015 in U.S. Appl. No. 13/941,134.
- USPTO; Restriction Requirement dated Apr. 30, 2015 in U.S. Appl. No. 13/941,216.
- USPTO; Non-Final Office Action dated Jul. 30, 2015 in U.S. Appl. No. 13/941,216.
- USPTO; Non-Final Office Action dated Jun. 15, 2016 in U.S. Appl. No. 13/941,216.
- USPTO; Notice of Allowance dated Sep. 13, 2016 in U.S. Appl. No. 13/941,216.
- USPTO; Restriction Requirement dated Sep. 16, 2014 in U.S. Appl. No. 13/948,055.
- USPTO; Non-Final Office Action dated Oct. 30, 2014 in U.S. Appl. No. 13/948,055.
- USPTO; Non-Final Office Action dated Jun. 29, 2015 in U.S. Appl. No. 13/966,782.
- USPTO; Final Office Action dated Jan. 4, 2016 in U.S. Appl. No. 13/966,782.
- USPTO; Notice of Allowance dated Oct. 7, 2015 in U.S. Appl. No. 13/973,777.
- USPTO; Non-Final Office Action dated Feb. 20, 2015 in U.S. Appl. No. 14/018,231.
- USPTO; Notice of Allowance dated Jul. 20, 2015 in U.S. Appl. No. 14/018,231.
- USPTO; Restriction Requirement Action dated Jan. 28, 2015 in U.S. Appl. No. 14/018,345.
- USPTO; Non-Final Office Action dated Apr. 7, 2015 in U.S. Appl. No. 14/018,345.
- USPTO; Final Office Action dated Sep. 14, 2015 in U.S. Appl. No. 14/018,345.
- USPTO; Notice of Allowance dated Jan. 14, 2016 in U.S. Appl. No. 14/018,345.
- USPTO; Notice of Allowance dated Mar. 17, 2016 in U.S. Appl. No. 14/018,345.
- USPTO; Non-Final Office Action dated Mar. 26, 2015 in U.S. Appl. No. 14/031,982.
- USPTO; Final Office Action dated Aug. 28, 2015 in U.S. Appl. No. 14/031,982.

(56)

References Cited

OTHER PUBLICATIONS

- USPTO; Notice of Allowance dated Nov. 17, 2015 in U.S. Appl. No. 14/031,982.
- USPTO; Non-Final Office Action dated Apr. 28, 2015 in U.S. Appl. No. 14/040,196.
- USPTO; Notice of Allowance dated Sep. 11, 2015 in U.S. Appl. No. 14/040,196.
- USPTO; Non-Final Action dated Dec. 3, 2015 in U.S. Appl. No. 14/050,150.
- USPTO; Final Office Action dated Jun. 15, 2016 in U.S. Appl. No. 14/050,150.
- USPTO; Final Office Action dated Jul. 8, 2016 in U.S. Appl. No. 14/050,150.
- USPTO; Notice of Allowance dated Oct. 20, 2016 in U.S. Appl. No. 14/050,150.
- USPTO; Non-Final Office Action dated Dec. 15, 2014 in U.S. Appl. No. 14/065,114.
- USPTO; Final Office Action dated Jun. 19, 2015 in U.S. Appl. No. 14/065,114.
- USPTO; Non-Final Office Action dated Oct. 7, 2015 in U.S. Appl. No. 14/065,114.
- USPTO; Notice of Allowance dated Feb. 22, 2016 in U.S. Appl. No. 14/065,114.
- USPTO; Non-Final Office Action dated Nov. 14, 2014 in U.S. Appl. No. 14/069,244.
- USPTO; Notice of Allowance dated Mar. 25, 2015 in U.S. Appl. No. 14/069,244.
- USPTO; Non-Final Office Action dated Mar. 19, 2015 in U.S. Appl. No. 14/079,302.
- USPTO; Final Office Action dated Sep. 1, 2015 in U.S. Appl. No. 14/079,302.
- USPTO; Non-Final Office Action dated Apr. 27, 2016 in U.S. Appl. No. 14/079,302.
- USPTO; Final Office Action dated Aug. 22, 2016 in U.S. Appl. No. 14/079,302.
- USPTO; Notice of Allowance dated Dec. 14, 2016 in U.S. Appl. No. 14/079,302.
- USPTO; Non-Final Office Action dated Jun. 14, 2016 in U.S. Appl. No. 14/090,750.
- USPTO; Final Office Action dated Sep. 28, 2016 in U.S. Appl. No. 14/090,750.
- USPTO; Non-Final Office Action dated Jun. 23, 2017 in U.S. Appl. No. 14/090,750.
- USPTO; Final Office Action dated Nov. 17, 2017 in U.S. Appl. No. 14/090,750.
- USPTO; Non-Final Office Action dated Mar. 12, 2018 in U.S. Appl. No. 14/090,750.
- USPTO; Non-Final Office Action dated Mar. 19, 2015 in U.S. Appl. No. 14/166,462.
- USPTO; Notice of Allowance dated Sep. 3, 2015 in U.S. Appl. No. 14/166,462.
- USPTO; Non-Final Office Action dated Nov. 17, 2015 in U.S. Appl. No. 14/172,220.
- USPTO; Office Action dated May 29, 2014 in U.S. Appl. No. 14/183,187.
- USPTO; Final Office Action dated Nov. 7, 2014 in U.S. Appl. No. 14/183,187.
- USPTO; Non-Final Office Action dated Mar. 16, 2015 in U.S. Appl. No. 14/183,187.
- USPTO; Final Office Action dated Jul. 10, 2015 in U.S. Appl. No. 14/183,187.
- USPTO; Non-Final Office Action dated Jan. 11, 2016 in U.S. Appl. No. 14/188,760.
- USPTO; Final Office Action dated Aug. 25, 2016 in U.S. Appl. No. 14/188,760.
- USPTO; Non-Final Office Action dated Mar. 23, 2017 in U.S. Appl. No. 14/188,760.
- USPTO; Final Office Action dated Oct. 5, 2017 in U.S. Appl. No. 14/188,760.
- USPTO; Non-Final Office Action dated Apr. 18, 2018 in U.S. Appl. No. 14/188,760.
- USPTO; Non-Final Office Action dated Oct. 8, 2015 in U.S. Appl. No. 14/218,374.
- USPTO; Final Office Action dated Feb. 23, 2016 in U.S. Appl. No. 14/218,374.
- USPTO; Restriction Requirement dated May 20, 2016 in U.S. Appl. No. 14/218,690.
- USPTO; Non-Final Office Action dated Jul. 15, 2016 in U.S. Appl. No. 14/218,690.
- USPTO; Final Office Action dated Nov. 14, 2016 in U.S. Appl. No. 14/218,690.
- USPTO; Non-Final Office Action dated Apr. 6, 2017 in U.S. Appl. No. 14/218,690.
- USPTO; Final Office Action dated Jul. 20, 2017 in U.S. Appl. No. 14/218,690.
- USPTO; Non-Final Office Action dated Jan. 11, 2018 in U.S. Appl. No. 14/218,690.
- USPTO; Final Office Action dated May 24, 2018 in U.S. Appl. No. 14/218,690.
- USPTO; Non-Final Office Action dated Sep. 22, 2015 in U.S. Appl. No. 14/219,839.
- USPTO; Final Office Action dated Mar. 25, 2016 in U.S. Appl. No. 14/219,839.
- USPTO; Non-Final Office Action dated Dec. 22, 2016 in U.S. Appl. No. 14/219,839.
- USPTO; Final Office Action dated Jul. 6, 2017 in U.S. Appl. No. 14/219,839.
- USPTO; Non-Final Office Action dated Mar. 27, 2018 in U.S. Appl. No. 14/219,839.
- USPTO; Non-Final Office Action dated Nov. 25, 2015 in U.S. Appl. No. 14/219,879.
- USPTO; Non-Final Office Action dated Dec. 23, 2016 in U.S. Appl. No. 14/219,879.
- USPTO; Advisory Action dated Oct. 5, 2017 in U.S. Appl. No. 14/219,879.
- USPTO; Non-Final Office Action dated Apr. 6, 2018 in U.S. Appl. No. 14/219,879.
- USPTO; Non-Final Office Action dated Sep. 18, 2015 in U.S. Appl. No. 14/244,689.
- USPTO; Notice of Allowance dated Feb. 11, 2016 in U.S. Appl. No. 14/244,689.
- USPTO; Non-Final Office Action dated Oct. 7, 2015 in U.S. Appl. No. 14/246,969.
- USPTO; Final Office Action dated May 4, 2016 in U.S. Appl. No. 14/246,969.
- USPTO; Non-Final Office Action dated Aug. 12, 2016 in U.S. Appl. No. 14/246,969.
- USPTO; Non-Final Office Action dated Nov. 20, 2015 in U.S. Appl. No. 14/260,701.
- USPTO; Notice of Allowance dated Jun. 2, 2016 in U.S. Appl. No. 14/260,701.
- USPTO; Notice of Allowance dated Feb. 23, 2016 in U.S. Appl. No. 14/327,134.
- USPTO; Non-Final Office Action dated Aug. 19, 2015 in U.S. Appl. No. 14/268,348.
- USPTO; Non-Final Office Action dated Jan. 6, 2016 in U.S. Appl. No. 14/268,348.
- USPTO; Final Office Action dated Apr. 29, 2016 in U.S. Appl. No. 14/268,348.
- USPTO; Non-Final Office Action dated Oct. 20, 2015 in U.S. Appl. No. 14/281,477.
- USPTO; Non-Final Office Action dated Jan. 13, 2017 in U.S. Appl. No. 14/444,744.
- USPTO; Final Office Action dated Jul. 10, 2017 in U.S. Appl. No. 14/444,744.
- USPTO; Non-Final Office Action dated Nov. 29, 2017 in U.S. Appl. No. 14/444,744.
- USPTO; Final Office Action dated Mar. 28, 2018 in U.S. Appl. No. 14/444,744.
- USPTO; Non-Final Office Action dated May 18, 2016 in U.S. Appl. No. 14/449,838.

(56)

References Cited

OTHER PUBLICATIONS

- USPTO; Non-Final Office Action dated Feb. 12, 2015 in U.S. Appl. No. 14/457,058.
- USPTO; Final Office Action dated Jul. 14, 2015 in U.S. Appl. No. 14/457,058.
- USPTO; Non-Final Office Action dated Nov. 6, 2015 in U.S. Appl. No. 14/457,058.
- USPTO; Final Office Acton dated Jun. 17, 2016 in U.S. Appl. No. 14/457,058.
- USPTO; Non-Final Office Action dated Oct. 6, 2016 in U.S. Appl. No. 14/457,058.
- USPTO; Final Office Acton dated May 4, 2017 in U.S. Appl. No. 14/457,058.
- USPTO; Non-Final Office Action dated Oct. 19, 2017 in U.S. Appl. No. 14/457,058.
- USPTO; Non-Final Office Action dated Sep. 16, 2016 in U.S. Appl. No. 14/465,252.
- USPTO; Final Office Action dated Nov. 1, 2016 in U.S. Appl. No. 14/465,252.
- USPTO; Non-Final Office Action dated Mar. 6, 2017 in U.S. Appl. No. 14/465,252.
- USPTO; Final Office Action dated Jun. 9, 2017 in U.S. Appl. No. 14/465,252.
- USPTO; Notice of Allowance dated Oct. 3, 2017 in U.S. Appl. No. 14/465,252.
- USPTO; Non-Final Office Action dated May 31, 2018 in U.S. Appl. No. 15/491,726.
- USPTO; Non-Final Office Action dated Nov. 24, 2015 in U.S. Appl. No. 14/498,036.
- USPTO; Final Office Action dated Apr. 5, 2016 in U.S. Appl. No. 14/498,036.
- USPTO; Non-Final Office Action dated Apr. 10, 2015 in U.S. Appl. No. 14/505,290.
- USPTO; Notice of Allowance dated Aug. 21, 2015 in U.S. Appl. No. 14/505,290.
- USPTO; Non-Final Office Action dated Dec. 17, 2015 in U.S. Appl. No. 14/508,296.
- USPTO; Final Office Action dated May 26, 2016 in U.S. Appl. No. 14/508,296.
- USPTO; Non-Final Office Action dated Sep. 8, 2016 in U.S. Appl. No. 14/508,296.
- USPTO; Final Office Action dated Dec. 7, 2016 in U.S. Appl. No. 14/508,296.
- USPTO; Restriction for Requirement dated Dec. 30, 2016 in U.S. Appl. No. 14/508,489.
- USPTO; Non-Final Office Action dated Apr. 6, 2017 in U.S. Appl. No. 14/508,489.
- USPTO; Final Office Action dated Oct. 4, 2017 in U.S. Appl. No. 14/508,489.
- USPTO; Non-Final Office Action dated May 5, 2018 in U.S. Appl. No. 14/508,489.
- USPTO; Non-Final Office Action dated Jan. 16, 2015 in U.S. Appl. No. 14/563,044.
- USPTO; Final Office Action dated Jul. 16, 2015 in U.S. Appl. No. 14/563,044.
- USPTO; Notice of Allowance dated Oct. 15, 2015 in U.S. Appl. No. 14/563,044.
- USPTO; Notice of Allowance dated Dec. 2, 2015 in U.S. Appl. No. 14/563,044.
- USPTO; Non-Final Office Action dated May 4, 2016 in U.S. Appl. No. 14/568,647.
- USPTO; Final Office Action dated Sep. 29, 2016 in U.S. Appl. No. 14/568,647.
- USPTO; Non-Final Office Action dated Feb. 2, 2017 in U.S. Appl. No. 14/568,647.
- USPTO; Final Office Action dated May 19, 2017 in U.S. Appl. No. 14/568,647.
- USPTO; Non-Final Office Action dated Sep. 14, 2017 in U.S. Appl. No. 14/568,647.
- USPTO; Final Office Action dated Jan. 23, 2018 in U.S. Appl. No. 14/568,647.
- USPTO; Non-Final Office Action dated May 25, 2018 in U.S. Appl. No. 14/568,647.
- USPTO; Non-Final Office Action dated Oct. 1, 2015 in U.S. Appl. No. 14/571,126.
- USPTO; Final Office Action dated Feb. 22, 2016 in U.S. Appl. No. 14/571,126.
- USPTO; Notice of Allowance dated Jun. 2, 2016 in U.S. Appl. No. 14/571,126.
- USPTO; Non-Final Office Action dated Nov. 25, 2015 in U.S. Appl. No. 14/598,532.
- USPTO; Notice of Allowance dated May 16, 2016 in U.S. Appl. No. 14/598,532.
- USPTO; Non-Final Office Action dated Jan. 15, 2016 in U.S. Appl. No. 14/606,364.
- USPTO; Final Office Action dated Jan. 12, 2017 in U.S. Appl. No. 14/606,364.
- USPTO; Non-Final Office Action dated May 10, 2017 in U.S. Appl. No. 14/606,364.
- USPTO; Non-Final Office Action dated Mar. 3, 2016 in U.S. Appl. No. 14/622,603.
- USPTO; Non-Final Office Action dated Oct. 19, 2017 in U.S. Appl. No. 14/645,234.
- USPTO; Non-Final Office Action dated May 16, 2018 in U.S. Appl. No. 14/645,234.
- USPTO; Non-Final Office Action dated Jun. 7, 2017 in U.S. Appl. No. 14/656,588.
- USPTO; Final Office Action dated Dec. 26, 2017 in U.S. Appl. No. 14/656,588.
- USPTO; Non-Final Office Action dated Apr. 6, 2018 in U.S. Appl. No. 14/656,588.
- USPTO; Non-Final Office Action dated Mar. 21, 2016 in U.S. Appl. No. 14/659,152.
- USPTO; Final Office Action dated Jul. 29, 2016 in U.S. Appl. No. 14/659,152.
- USPTO; Notice of Allowance dated Nov. 22, 2016 in U.S. Appl. No. 14/659,152.
- USPTO; Non-Final Office Action dated Sep. 7, 2017 in U.S. Appl. No. 14/660,755.
- USPTO; Restriction Requirement dated Sep. 11, 2017 in U.S. Appl. No. 14/660,755.
- USPTO; Notice of Allowance dated Oct. 2, 2017 in U.S. Appl. No. 14/660,755.
- USPTO; Notice of Allowance dated Mar. 25, 2016 in U.S. Appl. No. 14/693,138.
- USPTO; Requirement for Restriction dated Jul. 5, 2017 in U.S. Appl. No. 14/752,712.
- USPTO; Non-Final Office Action dated Aug. 3, 2017 in U.S. Appl. No. 14/752,712.
- USPTO; Final Office Action dated Nov. 29, 2017 in U.S. Appl. No. 14/752,712.
- USPTO; Advisory Action dated Feb. 15, 2018 in U.S. Appl. No. 14/752,712.
- USPTO; Non-Final Office Action dated Mar. 21, 2018 in U.S. Appl. No. 14/752,712.
- USPTO; Non-Final Office Action dated Nov. 29, 2017 in U.S. Appl. No. 14/793,323.
- USPTO; Final Office Action dated Mar. 29, 2018 in U.S. Appl. No. 14/793,323.
- USPTO; Non-Final Office Action dated Jun. 16, 2017 in U.S. Appl. No. 14/798,136.
- USPTO; Notice of Allowance dated Oct. 5, 2017 in U.S. Appl. No. 14/798,136.
- USPTO; Non-Final Office Action dated Mar. 30, 2016 in U.S. Appl. No. 14/808,979.
- USPTO; Final Office Acton dated Sep. 30, 2016 in U.S. Appl. No. 14/808,979.
- USPTO; Non-Final Office Action dated Dec. 20, 2016 in U.S. Appl. No. 14/808,979.
- USPTO; Final Office Action dated Jun. 8, 2017 in U.S. Appl. No. 14/808,979.

(56)

References Cited

OTHER PUBLICATIONS

- USPTO; Non-Final Office Action dated Sep. 21, 2017 in U.S. Appl. No. 14/808,979.
- USPTO; Final Office Action dated Mar. 14, 2018 in U.S. Appl. No. 14/808,979.
- USPTO; Non-Final Office Action dated Feb. 23, 2018 in U.S. Appl. No. 14/817,953.
- USPTO; Non-Final Office Action dated Sep. 9, 2016 in U.S. Appl. No. 14/829,565.
- USPTO; Final Office Action dated Feb. 9, 2017 in U.S. Appl. No. 14/829,565.
- USPTO; Non-Final Office Action dated Sep. 19, 2017 in U.S. Appl. No. 14/829,565.
- USPTO; Final Office Action dated Mar. 5, 2018 in U.S. Appl. No. 14/829,565.
- USPTO; Non-Final Office Action dated Apr. 29, 2016 in U.S. Appl. No. 14/835,637.
- USPTO; Final Office Action dated Nov. 25, 2016 in U.S. Appl. No. 14/835,637.
- USPTO; Non-Final Office Action dated Jul. 29, 2016 in U.S. Appl. No. 14/884,695.
- USPTO; Non-Final Office Action dated May 18, 2017 in U.S. Appl. No. 14/886,571.
- USPTO; Non-Final Office Action dated Dec. 1, 2016 in U.S. Appl. No. 14/919,536.
- USPTO; Final Office Action dated Mar. 28, 2017 in U.S. Appl. No. 14/919,536.
- USPTO; Non-Final Office Action dated Aug. 29, 2017 in U.S. Appl. No. 14/919,536.
- USPTO; Final Office Action dated May 11, 2018 in U.S. Appl. No. 14/919,536.
- USPTO; Non-Final Office Action dated Dec. 15, 2016 in U.S. Appl. No. 14/938,180.
- USPTO; Notice of Allowance dated Nov. 9, 2017 in U.S. Appl. No. 14/938,180.
- USPTO; Non-Final Office Action dated Apr. 14, 2017 in U.S. Appl. No. 14/956,115.
- USPTO; Final Office Action dated Jul. 21, 2017 in U.S. Appl. No. 14/956,115.
- USPTO; Notice of Allowance dated Dec. 14, 2017 in U.S. Appl. No. 14/956,115.
- USPTO; Notice of Allowance dated Feb. 3, 2017 in U.S. Appl. No. 14/977,291.
- USPTO; Non-Final Office Action dated Aug. 12, 2016 in U.S. Appl. No. 14/981,434.
- USPTO; Non-Final Office Action dated Jan. 12, 2017 in U.S. Appl. No. 14/981,468.
- USPTO; Non-Final Office Action dated Mar. 22, 2016 in U.S. Appl. No. 14/987,420.
- USPTO; Non-Final Office Action dated Dec. 14, 2016 in U.S. Appl. No. 14/997,683.
- USPTO; Final Office Action dated Apr. 14, 2017 in U.S. Appl. No. 14/997,683.
- USPTO; Non-Final Office Action dated Sep. 1, 2017 in U.S. Appl. No. 14/997,683.
- USPTO; Final Office Action dated Feb. 6, 2018 in U.S. Appl. No. 14/997,683.
- USPTO; Advisory Action dated May 2, 2018 in U.S. Appl. No. 14/997,683.
- USPTO; Non-Final Office Action dated Sep. 23, 2016 in U.S. Appl. No. 15/048,422.
- USPTO; Notice of Allowance dated May 4, 2017 in U.S. Appl. No. 15/048,422.
- USPTO; Requirement for Restriction dated Apr. 19, 2017 in U.S. Appl. No. 15/050,159.
- USPTO; Non-Final Office Action dated Aug. 4, 2017 in U.S. Appl. No. 15/050,159.
- USPTO; Notice of Allowance dated Feb. 7, 2018 in U.S. Appl. No. 15/050,159.
- USPTO; Non-Final Office Action dated Feb. 20, 2018 in U.S. Appl. No. 15/060,412.
- USPTO; Requirement for Restriction dated Jun. 4, 2018 in U.S. Appl. No. 15/067,028.
- USPTO; Non-Final Office Action dated Jan. 9, 2018 in U.S. Appl. No. 15/135,224.
- USPTO; Non-Final Office Action dated Jan. 9, 2018 in U.S. Appl. No. 15/135,258.
- USPTO; Non-Final Office Action dated Jan. 9, 2018 in U.S. Appl. No. 15/135,333.
- USPTO; Non-Final Office Action dated Nov. 21, 2016 in U.S. Appl. No. 15/144,481.
- USPTO; Final Office Action dated May 26, 2017 in U.S. Appl. No. 15/144,481.
- USPTO; Non-Final Office Action dated Sep. 21, 2017 in U.S. Appl. No. 15/144,481.
- USPTO; Notice of Allowance dated Apr. 11, 2018 in U.S. Appl. No. 15/144,481.
- USPTO; Non-Final Office Action dated Apr. 13, 2017 in U.S. Appl. No. 15/144,506.
- USPTO; Final Office Action dated Oct. 10, 2017 in U.S. Appl. No. 15/144,506.
- USPTO; Non-Final Office Action dated Nov. 28, 2016 in U.S. Appl. No. 15/203,632.
- USPTO; Final Office Action dated Jun. 7, 2017 in U.S. Appl. No. 15/203,632.
- USPTO; Notice of Allowance dated Sep. 20, 2017 in U.S. Appl. No. 15/203,632.
- USPTO; Non-Final Office Action dated Nov. 29, 2016 in U.S. Appl. No. 15/203,642.
- USPTO; Final Office Action dated Apr. 13, 2017 in U.S. Appl. No. 15/203,642.
- USPTO; Advisory Action dated Jun. 22, 2017 in U.S. Appl. No. 15/203,642.
- USPTO; Notice of Allowance dated Aug. 7, 2017 in U.S. Appl. No. 15/203,642.
- USPTO; Non-Final Office Action dated Jun. 1, 2017 in U.S. Appl. No. 15/205,827.
- USPTO; Final Office Action dated Oct. 16, 2017 in U.S. Appl. No. 15/205,827.
- USPTO; Non-Final Office Action dated May 14, 2018 in U.S. Appl. No. 15/205,827.
- USPTO; Non-Final Office Action dated Mar. 31, 2017 in U.S. Appl. No. 15/205,890.
- USPTO; Notice of Allowance dated Oct. 16, 2017 in U.S. Appl. No. 15/205,890.
- USPTO; Non-Final Office Action dated Jan. 20, 2017 in U.S. Appl. No. 15/210,256.
- USPTO; Notice of Allowance dated May 18, 2017 in U.S. Appl. No. 15/210,256.
- USPTO; Notice of Allowance dated Jul. 24, 2017 in U.S. Appl. No. 15/210,256.
- USPTO; Non-Final Office Action dated Apr. 21, 2017 in U.S. Appl. No. 15/222,715.
- USPTO; Non-Final Office Action dated Feb. 3, 2017 in U.S. Appl. No. 15/222,738.
- USPTO; Non-Final Office Action dated Jan. 17, 2017 in U.S. Appl. No. 15/222,749.
- USPTO; Final Office Action dated May 5, 2017 in U.S. Appl. No. 15/222,749.
- USPTO; Non-Final Office Action dated Sep. 7, 2017 in U.S. Appl. No. 15/222,749.
- USPTO; Final Office Action dated Jun. 4, 2018 in U.S. Appl. No. 15/222,749.
- USPTO; Non-Final Office Action dated Jan. 3, 2017 in U.S. Appl. No. 15/222,780.
- USPTO; Final Office Action dated May 5, 2017 in U.S. Appl. No. 15/222,780.
- USPTO; Non-Final Office Action dated Sep. 7, 2017 in U.S. Appl. No. 15/222,780.
- USPTO; Final Office Action dated May 17, 2018 in U.S. Appl. No. 15/222,780.

(56)

References Cited

OTHER PUBLICATIONS

- USPTO; Non-Final Office Action dated Aug. 28, 2017 in U.S. Appl. No. 15/254,724.
- USPTO; Notice of Allowance dated Jan. 17, 2018 in U.S. Appl. No. 15/254,724.
- USPTO; Non-Final Office Action dated May 22, 2018 in U.S. Appl. No. 15/262,990.
- USPTO; Non-Final Office Action dated Oct. 23, 2017 in U.S. Appl. No. 15/377,439.
- USPTO; Final Office Action dated Apr. 16, 2018 in U.S. Appl. No. 15/377,439.
- USPTO; Notice of Allowance dated Aug. 8, 2017 in U.S. Appl. No. 15/380,395.
- USPTO; Non-Final Office Action dated Jan. 4, 2018 in U.S. Appl. No. 15/380,921.
- USPTO; Non-Final Office Action dated Aug. 11, 2017 in U.S. Appl. No. 15/397,237.
- USPTO; Non-Final Office Action dated Apr. 12, 2017 in U.S. Appl. No. 15/397,319.
- USPTO; Final Office Action dated Jul. 12, 2017 in U.S. Appl. No. 15/397,319.
- USPTO; Notice of Allowance dated Dec. 15, 2017 in U.S. Appl. No. 15/397,319.
- USPTO; Non-Final Office Action dated Apr. 6, 2018 in U.S. Appl. No. 15/434,051.
- USPTO; Notice of Allowance dated Oct. 6, 2017 in U.S. Appl. No. 15/450,199.
- USPTO; Non-Final Office Action dated Dec. 15, 2017 in U.S. Appl. No. 15/466,149.
- USPTO; Non-Final Office Action dated Dec. 6, 2017 in U.S. Appl. No. 15/476,035.
- USPTO; Non-Final Office Action dated Oct. 4, 2017 in U.S. Appl. No. 15/489,453.
- USPTO; Final Office Action dated Apr. 19, 2018 in U.S. Appl. No. 15/489,453.
- USPTO; Non-Final Office Action dated Jan. 16, 2018 in U.S. Appl. No. 15/499,647.
- USPTO; Non-Final Office Action dated May 3, 2018 in U.S. Appl. No. 15/589,861.
- USPTO; Non-Final Office Action dated Apr. 4, 2018 in U.S. Appl. No. 15/592,730.
- USPTO; Non-Final Office Action dated Apr. 25, 2018 in U.S. Appl. No. 15/673,278.
- USPTO; Non-Final Office Action dated Jan. 18, 2018 in U.S. Appl. No. 15/683,701.
- USPTO; Requirement for Restriction dated May 11, 2018 in U.S. Appl. No. 15/711,989.
- USPTO; Non-Final Office Action dated Jun. 14, 2018 in U.S. Appl. No. 15/711,989.
- USPTO; Non-Final Office Action dated May 29, 2018 in U.S. Appl. No. 15/719,208.
- USPTO; Non-Final Office Action dated Apr. 19, 2018 in U.S. Appl. No. 15/726,959.
- USPTO; Non-Final Office Action dated Dec. 26, 2017 in U.S. Appl. No. 15/798,120.
- USPTO; Requirement for Restriction dated Apr. 6, 2018 in U.S. Appl. No. 15/798,201.
- USPTO; Non-Final Office Action dated Mar. 16, 2015 in U.S. Appl. No. 29/447,298.
- USPTO; Notice of Allowance dated Jul. 6, 2015 in U.S. Appl. No. 29/447,298.
- USPTO; Notice of Allowance dated Nov. 26, 2014 in U.S. Appl. No. 29/481,301.
- USPTO; Notice of Allowance dated Feb. 17, 2015 in U.S. Appl. No. 29/481,308.
- USPTO; Notice of Allowance dated Jan. 12, 2015 in U.S. Appl. No. 29/481,312.
- USPTO; Notice of Allowance dated Apr. 30, 2015 in U.S. Appl. No. 29/481,315.
- USPTO; Notice of Allowance dated May 11, 2015 in U.S. Appl. No. 29/511,011.
- USPTO; Notice of Allowance dated May 11, 2015 in U.S. Appl. No. 29/514,153.
- USPTO; Notice of Allowance dated Dec. 14, 2015 in U.S. Appl. No. 29/514,264.
- USPTO; Notice of Allowance dated Jun. 16, 2017 in U.S. Appl. No. 29/570,711.
- PCT; International Search report and Written Opinion dated Nov. 12, 2010 in Application No. PCT/US2010/030126.
- PCT; International Preliminary Report on Patentability dated Oct. 11, 2011 Application No. PCT/US2010/030126.
- PCT; International Search report and Written Opinion dated Jan. 20, 2011 in Application No. PCT/US2010/045368.
- PCT; International Search report and Written Opinion dated Feb. 6, 2013 in Application No. PCT/US2012/065343.
- PCT; International Search report and Written Opinion dated Feb. 13, 2013 in Application No. PCT/US2012/065347.
- PCT; International Search Report and Written Opinion dated Nov. 16, 2017 in Application No. PCT/IB2017/001015.
- PCT; International Search Report and Written Opinion dated Nov. 13, 2017 in Application No. PCT/IB2017/001050.
- PCT; International Search Report and Written Opinion dated Nov. 30, 2017 in Application No. PCT/IB2017/001070.
- PCT; International Search Report and Written Opinion dated Jan. 25, 2018 in Application No. PCT/IB2017/001262.
- PCT; International Search Report and Written Opinion dated Jun. 1, 2018 in Application No. PCT/IB2017/001644.
- PCT; International Search Report and Written Opinion dated Jun. 1, 2018 in Application No. PCT/IB2017/001656.
- Chinese Patent Office; Office Action dated Jan. 10, 2013 in Application No. 201080015699.9.
- Chinese Patent Office; Office Action dated Jan. 12, 2015 in Application No. 201080015699.9.
- Chinese Patent Office; Office Action dated May 24, 2013 in Application No. 201080036764.6.
- Chinese Patent Office; Office Action dated Jan. 2, 2014 in Application No. 201080036764.6.
- Chinese Patent Office; Office Action dated Jul. 1, 2014 in Application No. 201080036764.6.
- Chinese Patent Office; Office Action dated Feb. 8, 2014 in Application No. 201110155056.
- Chinese Patent Office; Office Action dated Sep. 16, 2014 in Application No. 201110155056.
- Chinese Patent Office; Office Action dated Feb. 9, 2015 in Application No. 201110155056.
- Japanese Patent Office; Office Action dated Jan. 25, 2014 in Application No. 2012-504786.
- Japanese Patent Office; Office Action dated Dec. 1, 2014 in Application No. 2012-504786.
- Korean Patent Office; Office Action dated Dec. 10, 2015 in Application No. 10-2010-0028336.
- Taiwan Patent Office; Office Action dated Jul. 4, 2014 in Application No. 099110511.
- Taiwan Patent Office; Office Action dated Dec. 19, 2014 in Taiwan Application No. 099127063.
- Taiwan Patent Office; Office Action dated May 13, 2016 in Taiwan Application No. 101142582.
- Bearzotti, et al., "Fast Humidity Response of a Metal Halide-Doped Novel Polymer," *Sensors and Actuators B*, 7, pp. 451-454, (1992).
- Becker et al., "Atomic Layer Deposition of Insulating Hafnium and Zirconium Nitrides," *Chem. Mater.*, 16, 3497-3501 (2004).
- Bhatnagar et al., "Copper Interconnect Advances to Meet Moore's Law Milestones," *Solid State Technology*, 52, 10 (2009).
- Buriak, "Organometallic Chemistry on Silicon and Germanium Surfaces," *Chemical Reviews*, 102, 5 (2002).
- Cant et al., "Chemisorption Sites on Porous Silica Glass and on Mixed-Oxide Catalysis," *Can. J. Chem.* 46, 1373 (1968).
- Chang et al. "Small-Subthreshold-Swing and Low-Voltage Flexible Organic Thin-Film Transistors Which Use HfLaO as the Gate Dielectric," *IEEE Electron Device Letters*, Feb. 2009, pp. 133-135; vol. 30, No. 2; IEEE Electron Device Society.

(56)

References Cited

OTHER PUBLICATIONS

- Chatterjee et al., "Sub-100nm Gate Length Metal Gate NMOS Transistors Fabricated by a Replacement by a Replacement Gate Process," IEEE Semiconductor Process and Device Center, 821-824 (1997).
- Chen et al., "A Self-Aligned Airgap Interconnect Scheme," IEEE International Interconnect Technology Conference, vol. 1-3, 146-148 (2009).
- Choi et al., "Improvement of Silicon Direct Bonding using Surfaces Activated by Hydrogen Plasma Treatment," Journal of the Korean Physical Society, 37, 6, 878-881 (2000).
- Choi et al., "Low Temperature Formation of Silicon Oxide Thin Films by Atomic Layer Deposition Using NH₃/O₂ Plasma," ECS Solid State Letters, 2(12) p. 114-p. 116 (2013).
- Coates, "Process Analytical Technology: Spectroscopic Tools and Implementation Strategies for the Chemical and Pharmaceutical Industries." Blackwell Publishing Ltd, 91-132, (2005).
- Crowell, "Chemical methods of thin film deposition: Chemical vapor deposition, atomic layer deposition, and related technologies," Journal of Vacuum Science & Technology A 21.5, (2003): S88-S95.
- Cui et al., "Impact of Reductive N₂/H₂ Plasma on Porous Low-Dielectric Constant SiCOH Thin Films," Journal of Applied Physics 97, 113302, 1-8 (2005).
- Dingemans et al., "Comparison Between Aluminum Oxide Surface Passivation Films Deposited with Thermal Aid," Plasma Aid and Pevcd, 35th IEEE PVCS, Jun. 2010.
- Drummond et al., "Hydrophobic Radiofrequency Plasma-Deposited Polymer Films: Dielectric Properties and Surface Forces," Colloids and Surfaces A, 129-130, 117-129 (2006).
- Easley et al., "Thermal Isolation of Microchip Reaction Chambers for Rapid Non-Contact DNA Amplification," J. Micromech. Microeng. 17, 1758-1766 (2007).
- Elam et al., "New Insights into Sequential Infiltration Synthesis," ECS Transactions, vol. 69, pp. 147-157 (2015).
- Ge et al., "Carbon Nanotube-Based Synthetic Gecko Tapes," Department of Polymer Science, PNAS, 10792-10795 (2007).
- George et al., "Atomic Layer Deposition: An Overview," Chem. Rev. 110, 111-131 (2010).
- Grill et al., "The Effect of Plasma Chemistry on the Damage Induced Porous SiCOH Dielectrics," IBM Research Division, RC23683 (W0508-008), Materials Science, 1-19 (2005).
- Gupta et al., "Conversion of Metal Carbides to Carbide Derived Carbon by Reactive Ion Etching in Halogen Gas," Proceedings of SPIE—The International Society for Optical Engineering and Nanotechnologies for Space Applications, ISSN: 0277-786X (2006).
- Harrison et al., "Poly-gate Replacement Through Contact Hole (PRETCH): A New Method for High-K/ Metal Gate and Multi-Oxide Implementation on Chip," IEEE (2004).
- Heo et al., "Structural Characterization of Nanoporous Low-Dielectric Constant SiCOH Films Using Organosilane Precursors," NSTI-Nanotech, vol. 4, 122-123 (2007).
- Henke et al., "X-Ray Interactions: Photo absorption, Scattering, Transmission, and Reflection at E=50-30,000 eV, Z=1-92," Atomic Data and Nuclear Data Tables, 54, 181-342 (1993).
- H.J. Yun et al., "Comparison of Atomic Scale Etching of Poly-Si in Inductively Coupled Ar and He Plasmas", Korean Journal of Chemical Engineering, vol. 24, 670-673 (2007).
- Hubert et al., "A Stacked SONOS Technology, up to 4 Levels and 6nm Crystalline Nanowires, With Gate-All-Around or Independent Gates (-Flash), Suitable for Full 3D Integration," Minatec, IEDM09-637-640 (2009).
- Jones et al., "Growth of Aluminum Films by Low Pressure Chemical Vapour Deposition Using Tertiarybutylaluminium," Journal of Crystal Growth 135, pp. 285-289, Elsevier Science B.V. (1994).
- Jones et al., "Recent Developments in Metalorganic Precursors for Metalorganic Chemical Vapour Deposition," Journal of Crystal Growth 146, pp. 503-510, Elsevier Science B.V. (1995).
- Jung et al., "Double Patterning of Contact Array with Carbon Polymer," Proc. of SPIE, 6924, 69240C, 1-10 (2008).
- Katamreddy et al., "Ald and Characterization of Aluminum Oxide Deposited on Si(100) using Tris(diethylamino) Aluminum and Water Vapor," Journal of the Electrochemical Society, 153 (10) C701-C706 (2006).
- Kim et al., "Passivation Effect on Low-k S/OC Dielectrics by H₂ Plasma Treatment," Journal of the Korean Physical Society, 40, 1, 94-98 (2002).
- Kim et al., "Characteristics of Low Temperature High Quality Silicon Oxide by Plasma. Enhanced Atomic Layer Deposition with In-Situ Plasma Densification Process," The Electrochemical Society, ECS Transactions, College of Information and Communication Engineering, Sungkyunkwan University, 53(1), 321-329 (2013).
- King, Plasma Enhanced Atomic Layer Deposition of SiN_x: H and SiO₂, J. Vac. Sci. Technol., A29(4) (2011).
- Klug et al., "Atomic Layer Deposition of Amorphous Niobium Carbide-Based Thin Film Superconductors," The Journal of Physical Chemistry C, vol. 115, pp. 25063-25071, (2011).
- Kobayshi, et al., "Temperature Dependence of SiO₂ Film Growth with Plasma-Enhanced Atomic Layer Deposition," regarding Thin Solid Films, published by Elsevier in the International Journal on the Science and Technology of Condensed Matter, in vol. 520, No. 11, 3994-3998 (2012).
- Koo et al., "Characteristics of Al₂O₃ Thin Films Deposited Using Dimethylaluminum Isopropoxide and Trimethylaluminum Precursors by the Plasma-Enhanced Atomic-Layer Deposition Method," Journal of Physical Society, 48, 1, 131-136 (2006).
- Koutsokeras et al. "Texture and Microstructure Evolution in Single-Phase Ti_xTa_{1-x}N Alloys of Rocksalt Structure," Journal of Applied Physics, 110, pp. 043535-1-043535-6, (2011).
- Knoops et al., "Atomic Layer Deposition of Silicon Nitride from Bis(tert-butyloamino) silane and N₂ Plasma," Applied Materials & Interfaces, American Chemical Society, A-E (2015).
- Krenek et al. "IR Laser CVD of Nanodisperse Ge—Si—Sn Alloys Obtained by Dielectric Breakdown of GeH₄/SiH₄/SnH₄ Mixtures", NanoCon 2014, Nov. 5-7, Brno, Czech Republic, EU.
- Kurosawa et al., "Synthesis and Characterization of Plasma-Polymerized Hexamethyldisiloxane Films," Thin Solid Films, 506-507, 176-179 (2006).
- Lanford et al., "The Hydrogen Content of Plasmadeposited Silicon Nitride," J. Appl. Phys., 49, 2473 (1978).
- Lee et al., Layer Selection by Multi-Level Permutation in 3-D Stacked NAND Flash Memory, IEEE Electron Device Letters, vol. 37, No. 7, 866-869 (2016).
- Lieberman, et al., "Principles of Plasma Discharges and Materials Processing," Second Edition, 368-381.
- Lim et al., "Low-Temperature Growth of SiO₂ Films by Plasma-Enhanced Atomic Layer Deposition," ETRI Journal, 27 (1), 118-121 (2005).
- Liu et al., "Research, Design, and Experiment of End Effector for Wafer Transfer Robot," Industrial Robot: An International Journal, 79-91 (2012).
- Longrie et al., "Plasma-Enhanced ALD of Platinum with O₂, N₂ and NH₃ Plasmas", ECS Journal of Solid State Science and Technology, vol. 1, pp. Q123-Q129 (2012).
- Mackus et al., "Optical Emission Spectroscopy as a Tool for Studying Optimizing and Monitoring Plasma-Assisted Atomic Layer Deposition Processes," Journal of Vacuum Science and Technology, 77-87 (2010).
- Maeno, "Gecko Tape Using Carbon Nanotubes," Nitto Denko Gihou, 47, 48-51.
- Maeng et al. Electrical properties of atomic layer disposition HfO₂ and HfO_xNy on Si substrates with various crystal orientations, Journal of the Electrochemical Society, Apr. 2008, p. H267-H271, vol. 155, No. 4, Department of Materials Science and Engineering, Pohang University of Science and Technology, Pohang, Korea.
- Marsik et al., "Effect of Ultraviolet Curing Wavelength on Low-k Dielectric Material Properties and Plasma Damage Resistance," Sciencedirect.com, 519, 11, 3619-3626 (2011).
- Mason et al., "Hydrolysis of Tri-tert-butylaluminum: The First Structural Characterization of Alkylaluminumoxanes [(R₂Al)₂O]_n and (RAIO)_n," J. American Chemical Society, vol. 115, No. 12, pp. 4971-4984 (1993).

(56)

References Cited

OTHER PUBLICATIONS

- Massachusetts Institute of Technology Lincoln Laboratory, "Solid State Research," Quarterly Technical Report (1995).
- Maydannik et al., "Spatial atomic layer deposition: Performance of low temperature H₂O and O₃ oxidant chemistry for flexible electronics encapsulation", *Journal of Vacuum Science and Technology: Part A AVS/ AIP*, vol. 33 (1901).
- Meng et al., "Atomic Layer of Deposition of Silicon Nitride Thin Films: A Review of Recent Progress, Challenges, and Outlooks," *Materials*, 9, 1007 (2016).
- Moeen, "Design, Modelling and Characterization of Si/SiGe Structures for IR Bolometer Applications," KTH Royal Institute of Technology. Information and Communication Technology, Department of Integrated Devices and Circuits, Stockholm Sweden (2015).
- Morishige et al., "Thermal Desorption and Infrared Studies of Ammonia Amines and Pyridines Chemisorbed on Chromic Oxide," *J. Chem. Soc., Faraday Trans. 1*, 78, 2947-2957 (1982).
- Mosleh et al., "Enhancement of Material Quality of (Si)GeSn Films Grown by SnCl₄ Precursor," *ECS Transactions*, 69 (5), 279-285 (2015).
- Mukai et al., "A Study of CD Budget in Spacer Patterning Technology," *Proc. of SPIE*, 6924, 1-8 (2008).
- Nigamananda et al., "Low-Temperature (<200°C) Plasma Enhanced Atomic Deposition of Dense Titanium Nitride Thin Films." Nogueira et al., "Production of Highly Hydrophobic Films Using Low Frequency and High Density Plasma," *Revista Brasileira de Aplicacoes de Vacuo*, 25(1), 45-53 (2006).
- Novaro et al. Theoretical Study on a Reaction Pathway of Ziegler-Natta-Type Catalysis, *J. Chem. Phys.* 68(5), Mar. 1, 1978 p. 2337-2351.
- S. Okamoto et al., "Luminescent Properties of Pr³⁺—sensitized LaPO₄: Gd³⁺ Ultraviolet-B Phosphor Under Vacuum-Ultraviolet Light Excitation," *J. App. Phys.* 106, 013522 (2009).
- Park "Substituted Aluminum Metal Gate on High-K Dielectric for Low Work-Function and Fermi-Level Pinning Free," 4 pages, *IEEE 0-7803-8684-1/04* (2004).
- Portet et al., "Impact of Synthesis Conditions on Surface Chemistry and Structure of Carbide-Derived Carbons," *Thermochimica Acta*, 497, 137-142 (2010).
- Potts et al., "Low Temperature Plasma-Enhanced Atomic Layer Deposition of metal Oxide Thin Films," *Journal of the Electrochemical Society*, 157, 66-74 (2010).
- Potts et al., "Room-Temperature ALD of Metal Oxide Thin Films by Energy-Enhanced ALD", *Chemical Vapor Deposition*, vol. 19, pp. 125-133 (2013).
- Presser, et al., "Effect of Pore Size on Carbon Dioxide Sorption by Carbide Derived Carbon," *Energy & Environmental Science* 4.8, 3059-3066 (2011).
- Provine et al., "Correlation of Film Density and Wet Etch Rate in Hydrofluoric Acid of Plasma Enhanced Atomic Layer Deposited Silicon Nitride," *AIP Advances*, 6 (2016).
- Radamson et al. "Growth of Sn-alloyed Group IV Materials for Photonic and Electronic Applications", Chapter 5 pp. 129-144, *Manufacturing Nano Structures*.
- Sakuma et al., "Highly Scalable Horizontal Channel 3-D NAND Memory Excellent in Compatibility with Conventional Fabrication Technology," *IEEE Electron Device Letters*, vol. 34, No. 9, 1142-1144 (2013).
- Salim, "In-situ Fourier Transform Infrared Spectroscopy of Chemistry and Growth in Chemical Vapor Deposition," Massachusetts Institute of Technology, 187 pages (1995).
- Salim et al., "In Situ Concentration Monitoring in a Vertical OMVPE Reactor by Fiber-Optics-Based Fourier Transform Infrared Spectroscopy," *Journal of Crystal Growth* 169, pp. 443-449, Elsevier Science B.V. (1996).
- Schmatz et al., "Unusual Isomerization Reactions in 1,3-Diaza-2-Silyclopentanes." *Organometallics*, 23, 1180-1182 (2004).
- Scientific and Technical Information Center EIC 2800 Search Report dated Feb. 16, 2012.
- Selvaraj et al., "Selective Atomic Layer Deposition of Zirconia on Copper Patterned Silicon Substrates Using Ethanol as Oxygen Source as Well as Copper Reductant," *J. Vac. Sci. Technol. A*32(1), (2014).
- Selvaraj et al., "Surface Selective Atomic Layer Deposition of Hafnium Oxide for Copper Diffusion Barrier Application Using Tetrakis (diethylamino) Hafnium and Ethanol," 225th ECS Meeting, Meeting Abstract, (May 12, 2014).
- S.D. Athavale and D.J. Economou, "Realization of Atomic Layer Etching of Silicon", *Journal of Vacuum Science and Technology B*, vol. 14, year 1996, pp. 3702-3705.
- Shamma et al., "PDL Oxide Enabled Doubling," *Proc. of SPIE*, 6924, 69240D, 1-10 (2008).
- Tseng et al., "Etch Properties of Resists Modified by Sequential Infiltration Synthesis," *American Vacuum Society* (2011).
- Tseng et al., "Enhanced Block Copolymer Lithography Using Sequential Infiltration Synthesis," *Journal of Physical Chemistry*, vol. 5, 17725-17729 (2011).
- Varma, et al., "Effect of Metal Halides on Thermal, Mechanical, and Electrical Properties of Polypyromelitimide Films," *Journal of Applied Polymer Science*, vol. 32, pp. 3987-4000, (1986).
- Voltaix, "Material Safety Data Sheet for: Trisilylamine", pp. 1-8, (2014).
- Wang et al., "Tertiarybutylaluminum as an Organometallic Source for Epitaxial Growth of AlGaSb," *Appl. Phys. Lett.* 67 (10), Sep. 4, pp. 1384-1386, *American Institute of Physics* (1995).
- Wirths, et al., "SiGeSn Growth studies Using Reduced Pressure Chemical Vapor Deposition Towards Optoelectronic Applications," *This Solid Films*, 557, 183-187 (2014).
- Yoshida, et al., "Threshold Voltage Tuning for 10NM and Beyond CMOS Integration," *Solid State Technology*, 57(7): 23-25 (2014).
- Yu et al., "Modulation of the Ni FUSI Workfunction by Yb Doping: from Midgap to N-Type Band-Edge," 4 pages, *IEEE 0-7803-9269-8/05* (2005).
- Yun et al., "Behavior of Various Organosilicon Molecules in PECVD Processes for Hydrocarbon-Doped Silicon Oxide Films," *Solid State Phenomena*, vol. 124-126, 347-350 (2007).
- Yun et al., "Single-Crystalline Si Stacked Array (STAR) NAND Flash Memory," *IEEE Transactions on Electron Devices*, vol. 58, No. 4, 1006-1014 (2011).
- Yun et al., "Effect of Plasma on Characteristics of Zirconium Oxide Films Deposited by Plasma-Enhanced Atomic Layer Deposition," *Electrochemical and Solid State Letters*, 8(11) F47-F50 (2005).
- Yushin et al., "Carbon-Derived Carbon," Department of Materials Science and Engineering, Taylor & Francis Group, LLC (2006).
- Chemistry Stack Exchange, "Why is CF₄ Non-Polar and CHF₃ Polar," <https://chemistry.stackexchange.com/questions/31604/why-is-cf4-non-polar-and-chf3-polar>, (2015).
- PCT; International Preliminary Report on Patentability dated Nov. 24, 2009 and International Search Report dated Jul. 31, 208 in Application No. PCT/US2008/063919.
- PCT; International Preliminary Report on Patentability dated Feb. 24, 2010 in Application No. PCT/US2008/074063.
- PCT; International Preliminary Report on Patentability dated Nov. 26, 2009 in Application No. PCT/US2009/043454.
- PCT; International Preliminary Report on Patentability dated Jun. 14, 2011 in Application No. PCT/US2009/066377.
- PCT; International Preliminary Report on Patentability dated Nov. 9, 2011 in Application No. PCT/US2010/033244.
- PCT; International Preliminary Report on Patentability dated Nov. 9, 2011 in Application No. PCT/US2010/033248.
- PCT; International Preliminary Report on Patentability dated Nov. 9, 2011 in Application No. PCT/US2010/033252.
- USPTO; Notice of Allowance dated Jul. 26, 2005 in U.S. Appl. No. 10/033,058.
- USPTO; Non-Final Office Action dated Aug. 25, 2005 in U.S. Appl. No. 10/191,635.
- USPTO; Final Office Action dated Apr. 25, 2006 in U.S. Appl. No. 10/191,635.
- USPTO; Non-Final Office Action dated Nov. 20, 2006 in U.S. Appl. No. 10/191,635.
- USPTO; Notice of Allowance dated May 21, 2007 in U.S. Appl. No. 10/191,635.

(56)

References Cited

OTHER PUBLICATIONS

USPTO; Notice of Allowance dated Feb. 20, 2008 in U.S. Appl. No. 10/191,635.
USPTO; Non-Final Office Action dated May 13, 2003 in U.S. Appl. No. 10/222,229.
USPTO; Non-Final Office Action dated Oct. 22, 2003 in U.S. Appl. No. 10/222,229.
USPTO; Final Office Action dated Mar. 22, 2004 in U.S. Appl. No. 10/222,229.
USPTO; Advisory Action dated Oct. 7, 2004 in U.S. Appl. No. 10/222,229.
USPTO; Non-Final Office Action dated Dec. 22, 2004 in U.S. Appl. No. 10/222,229.
USPTO; Final Office Action dated Jun. 20, 2005 in U.S. Appl. No. 10/222,229.
USPTO; Advisory Action dated Nov. 16, 2005 in U.S. Appl. No. 10/222,229.
USPTO; Notice of Allowance dated Mar. 8, 2006 in U.S. Appl. No. 10/222,229.
USPTO; Non-Final Office Action dated Jan. 26, 2005 in U.S. Appl. No. 10/838,510.
USPTO; Notice of Allowance dated Jul. 12, 2005 in U.S. Appl. No. 10/838,510.
USPTO; Non-Final Office Action dated Mar. 28, 2010 in U.S. Appl. No. 12/121,085.
USPTO; Notice of Allowance dated Jul. 26, 2010 in U.S. Appl. No. 12/121,085.
USPTO; Notice of Allowance dated Oct. 4, 2010 in U.S. Appl. No. 12/121,085.
USPTO; Final Office Action dated Dec. 28, 2010 in U.S. Appl. No. 12/140,809.
USPTO; Notice of Allowance dated Mar. 17, 2011 in U.S. Appl. No. 12/140,809.
USPTO; Requirement for Restriction dated Sep. 10, 2010 in U.S. Appl. No. 12/148,956.
USPTO; Non-Final Office Action dated Mar. 15, 2011 in U.S. Appl. No. 12/193,924.
USPTO; Final Office Action dated Sep. 30, 2011 in U.S. Appl. No. 12/193,924.
USPTO; Non-Final Office Action dated Oct. 24, 2012 in U.S. Appl. No. 12/193,924.
USPTO; Final Office Action dated Apr. 17, 2013 in U.S. Appl. No. 12/193,924.
USPTO; Advisory Action dated Jul. 9, 2013 in U.S. Appl. No. 12/193,924.
USPTO ; Non-Final Office Action dated Jul. 28, 2011 in U.S. Appl. No. 12/330,096.
USPTO ; Final Office Action dated Jan. 13, 2012 in U.S. Appl. No. 12/330,096.
USPTO; Notice of Allowance dated Mar. 6, 2012 in U.S. Appl. No. 12/330,096.
USPTO; Non-Final Office Action dated Mar. 20, 2012 in U.S. Appl. No. 12/330,096.
USPTO; Notice of Allowance dated Jun. 7, 2012 in U.S. Appl. No. 12/330,096.
USPTO; Notice of Allowance dated Apr. 2, 2012 in U.S. Appl. No. 12/416,809.
USPTO; Advisory Action dated Feb. 3, 2012 in U.S. Appl. No. 12/416,809.
USPTO; Non-Final Office Action dated Aug. 3, 2011 in U.S. Appl. No. 12/436,300.
USPTO; Final Office Action dated Jan. 23, 2012 in U.S. Appl. No. 12/436,300.
USPTO; Advisory Action dated Mar. 6, 2012 in U.S. Appl. No. 12/436,300.
USPTO; Non-Final Office Action dated May 22, 2012 in U.S. Appl. No. 12/436,300.
USPTO; Notice of Allowance dated Nov. 28, 2012 in U.S. Appl. No. 12/436,300.

USPTO; Restriction Requirement dated Dec. 20, 2011 in U.S. Appl. No. 12/436,306.
USPTO; Non-Final Office Action dated Apr. 11, 2012 in U.S. Appl. No. 12/436,306.
USPTO; Final Office Action dated Sep. 26, 2012 in U.S. Appl. No. 12/436,306.
USPTO; Non-Final Office Action dated May 31, 2013 in U.S. Appl. No. 12/436,306.
USPTO; Final Office Action dated Oct. 17, 2013 in U.S. Appl. No. 12/436,306.
USPTO; Advisory Action dated Oct. 1, 2014 in U.S. Appl. No. 12/436,306.
USPTO; Non-Final Office Action dated Feb. 4, 2014 in U.S. Appl. No. 12/436,306.
USPTO; Final Office Action dated Jun. 23, 2014 in U.S. Appl. No. 12/436,306.
USPTO; Non-Final Office Action dated Feb. 3, 2015 in U.S. Appl. No. 12/436,306.
USPTO; Final Office Action dated May 13, 2015 in U.S. Appl. No. 12/436,306.
USPTO; Non-Final Office Action dated Oct. 14, 2015 in U.S. Appl. No. 12/436,306.
USPTO; Final Office Action dated Dec. 31, 2015 in U.S. Appl. No. 12/436,306.
USPTO; Notice of Allowance dated Feb. 3, 2016 in U.S. Appl. No. 12/436,306.
USPTO; Non-Final Office Action dated Aug. 3, 2011 in U.S. Appl. No. 12/436,315.
USPTO; Notice of Allowance dated Nov. 17, 2011 in U.S. Appl. No. 12/436,315.
USPTO; Advisory Action dated Jul. 13, 2011 in U.S. Appl. No. 12/553,759.
USPTO; Advisory Action dated Jul. 23, 2013 in U.S. Appl. No. 12/618,355.
USPTO; Advisory Action dated Mar. 4, 2016 in U.S. Appl. No. 12/618,355.
USPTO; Advisory Action dated May 16, 2017 in U.S. Appl. No. 12/618,355.
USPTO; Final Office Action dated Aug. 10, 2018 in U.S. Appl. No. 12/618,355.
USPTO; Advisory Action dated Aug. 9, 2012 in U.S. Appl. No. 12/618,419.
USPTO; Notice of Allowance dated Oct. 9, 2013 in U.S. Appl. No. 12/618,419.
USPTO; Requirement for Restriction dated Sep. 12, 2011 in U.S. Appl. No. 12/718,731.
USPTO; Advisory Action dated Jul. 1, 2013 in U.S. Appl. No. 12/847,848.
USPTO; Requirement for Restriction dated Jul. 22, 2013 in U.S. Appl. No. 12/910,607.
USPTO; Advisory Action dated Jul. 9, 2014 in U.S. Appl. No. 12/910,607.
USPTO; Advisory Action dated Jul. 8, 2013 in U.S. Appl. No. 12/953,870.
USPTO; Non-Final Office Action dated Aug. 28, 2013 in U.S. Appl. No. 12/953,870.
USPTO; Final Office Action dated Apr. 17, 2014 in U.S. Appl. No. 12/953,870.
USPTO; Advisory Action dated Jun. 12, 2014 in U.S. Appl. No. 13/102,980.
USPTO; Notice of Allowance dated Sep. 17, 2014 in U.S. Appl. No. 13/102,980.
USPTO; Requirement for Restriction dated Jun. 5, 2014 in U.S. Appl. No. 13/154,271.
USPTO; Requirement for Restriction dated Apr. 6, 2016 in U.S. Appl. No. 13/166,367.
USPTO; Advisory Action dated Apr. 21, 2017 in U.S. Appl. No. 13/166,367.
USPTO; Requirement for Restriction dated Jun. 18, 2014 in U.S. Appl. No. 13/169,951.
USPTO; Advisory Action dated May 13, 2016 in U.S. Appl. No. 13/169,951.

(56)

References Cited

OTHER PUBLICATIONS

- USPTO; Advisory Action dated Feb. 15, 2017 in U.S. Appl. No. 13/169,951.
- USPTO; Advisory Action dated Feb. 8, 2018 in U.S. Appl. No. 13/169,951.
- USPTO; Advisory Action dated Dec. 17, 2014 in U.S. Appl. No. 13/181,407.
- USPTO; Requirement for Restriction Sep. 25, 2012 in U.S. Appl. No. 13/184,351.
- USPTO; Advisory Action dated Nov. 7, 2013 in U.S. Appl. No. 13/184,351.
- USPTO; Advisory Action dated May 18, 2015 in U.S. Appl. No. 13/184,351.
- USPTO; Advisory Action dated Oct. 4, 2017 in U.S. Appl. No. 13/184,351.
- USPTO; Non-Final Office Action dated Jul. 26, 2018 in U.S. Appl. No. 13/184,351.
- USPTO; Restriction Requirement dated Aug. 21, 2014 in U.S. Appl. No. 13/187,300.
- USPTO; Advisory Action dated Mar. 28, 2016 in U.S. Appl. No. 13/283,408.
- USPTO; Restriction Requirement dated Oct. 2, 2013 in U.S. Appl. No. 13/312,591.
- USPTO; Advisory Action dated Aug. 26, 2014 in U.S. Appl. No. 13/312,591.
- USPTO; Notice of Allowance dated Jun. 11, 2015 in U.S. Appl. No. 13/312,591.
- USPTO; Requirement for Restriction dated Nov. 26, 2013 in U.S. Appl. No. 13/333,420.
- USPTO; Advisory Action dated Mar. 27, 2013 in U.S. Appl. No. 13/406,791.
- USPTO; Advisory Action dated Oct. 29, 2013 in U.S. Appl. No. 13/406,791.
- USPTO; Advisory Action dated Apr. 22, 2015 in U.S. Appl. No. 13/411,271.
- USPTO; Advisory Action dated Mar. 31, 2014 in U.S. Appl. No. 13/550,419.
- USPTO; Advisory Action dated Apr. 16, 2015 in U.S. Appl. No. 13/563,066.
- USPTO; Non-Final Office Action dated May 28, 2013 in U.S. Appl. No. 13/563,274.
- USPTO; Notice of Allowance dated Sep. 27, 2013 in U.S. Appl. No. 13/563,274.
- USPTO; Advisory Action dated May 5, 2014 in U.S. Appl. No. 13/565,564.
- USPTO; Notice of Allowance dated Sep. 13, 2013 in U.S. Appl. No. 13/566,069.
- USPTO; Advisory Action dated Sep. 2, 2015 in U.S. Appl. No. 13/597,108.
- USPTO; Notice of Allowance dated Mar. 7, 2017 in U.S. Appl. No. 13/597,108.
- USPTO; Restriction Requirement dated Jul. 9, 2013 in U.S. Appl. No. 13/612,538.
- USPTO; Notice of Allowance dated Feb. 25, 2015 in U.S. Appl. No. 13/612,538.
- USPTO; Requirement for Restriction dated Feb. 4, 2015 in U.S. Appl. No. 13/646,403.
- USPTO; Requirement for Restriction dated Apr. 11, 2014 in U.S. Appl. No. 13/646,471.
- USPTO; Advisory Action dated Nov. 14, 2014 in U.S. Appl. No. 13/646,471.
- USPTO; Advisory Action dated Apr. 15, 2016 in U.S. Appl. No. 13/646,471.
- USPTO; Final Office Action dated Oct. 20, 2016 in U.S. Appl. No. 13/646,471.
- USPTO; Restriction Requirement dated Mar. 4, 2015 in U.S. Appl. No. 13/651,144.
- USPTO; Advisory Action dated Apr. 19, 2018 in U.S. Appl. No. 13/651,144.
- USPTO; Requirement for Restriction dated Dec. 24, 2014 in U.S. Appl. No. 13/665,366.
- USPTO; Final Office Action dated Mar. 1, 2016 in U.S. Appl. No. 13/665,366.
- USPTO; Advisory Action dated May 13, 2016 in U.S. Appl. No. 13/665,366.
- USPTO; Non-Final Office Action dated Jun. 17, 2016 in U.S. Appl. No. 13/665,366.
- USPTO; Final Office Action dated May 3, 2017 in U.S. Appl. No. 13/665,366.
- USPTO; Notice of Allowance dated Aug. 24, 2015 in U.S. Appl. No. 13/677,133.
- USPTO; Notice of Allowance dated Mar. 17, 2015 in U.S. Appl. No. 13/677,151.
- USPTO; Advisory Action dated Apr. 6, 2016 in U.S. Appl. No. 13/727,324.
- USPTO; Non-Final Office Action dated Sep. 16, 2013 in U.S. Appl. No. 13/760,160.
- USPTO; Final Office Action dated Dec. 27, 2013 in U.S. Appl. No. 13/760,160.
- USPTO; Non-Final Office Action dated Jun. 4, 2014 in U.S. Appl. No. 13/760,160.
- USPTO; Final Office Action dated Sep. 25, 2014 in U.S. Appl. No. 13/760,160.
- USPTO; Final Office Action dated Jan. 28, 2015 in U.S. Appl. No. 13/760,160.
- USPTO; Final Office Action dated May 12, 2015 in U.S. Appl. No. 13/760,160.
- USPTO; Notice of Allowance dated Oct. 21, 2015 in U.S. Appl. No. 13/760,160.
- USPTO; Notice of Allowance dated Jan. 20, 2016 in U.S. Appl. No. 13/760,160.
- USPTO; Advisory Action dated Jul. 13, 2016 in U.S. Appl. No. 13/791,246.
- USPTO; Notice of Allowance dated Oct. 19, 2016 in U.S. Appl. No. 13/791,246.
- USPTO; Advisory Action dated Jul. 14, 2016 in U.S. Appl. No. 13/791,339.
- USPTO; Advisory Action dated Jun. 29, 2015 in U.S. Appl. No. 13/901,372.
- USPTO; Advisory Action dated Dec. 11, 2014 in U.S. Appl. No. 13/912,666.
- USPTO; Requirement for Restriction dated Sep. 4, 2014 in U.S. Appl. No. 13/915,732.
- USPTO; Non-Final Office Action dated Jan. 14, 2014 in U.S. Appl. No. 13/941,226.
- USPTO; Non-Final Office Action dated Jul. 8, 2014 in U.S. Appl. No. 13/941,226.
- USPTO; Non-Final Office Action dated Feb. 3, 2015 in U.S. Appl. No. 13/941,226.
- USPTO; Final Office Action dated Feb. 12, 2016 in U.S. Appl. No. 13/941,226.
- USPTO; Advisory Action dated Jul. 29, 2016 in U.S. Appl. No. 13/941,226.
- USPTO; Non-Final Office Action dated Aug. 8, 2017 in U.S. Appl. No. 13/941,226.
- USPTO; Notice of Allowance dated Feb. 27, 2015 in U.S. Appl. No. 13/948,055.
- USPTO; Notice of Allowance dated Mar. 31, 2015 in U.S. Appl. No. 13/948,055.
- USPTO; Notice of Allowance dated Mar. 21, 2016 in U.S. Appl. No. 13/966,782.
- USPTO; Non-Final Office Action Restriction dated Jan. 2, 2015 in U.S. Appl. No. 14/040,196.
- USPTO; Advisory Action dated Aug. 24, 2015 in U.S. Appl. No. 14/065,114.
- USPTO; Non-Final Office Action dated Dec. 23, 2015 in U.S. Appl. No. 14/079,302.
- USPTO; Requirement for Restriction dated Aug. 11, 2015 in U.S. Appl. No. 14/090,750.
- USPTO; Non-Final Office Action dated Sep. 9, 2015 in U.S. Appl. No. 14/090,750.

(56)

References Cited

OTHER PUBLICATIONS

- USPTO; Final Office Action dated Feb. 11, 2016 in U.S. Appl. No. 14/090,750.
- USPTO; Advisory Action dated May 5, 2016 in U.S. Appl. No. 14/090,750.
- USPTO; Advisory Action dated Dec. 21, 2016 in U.S. Appl. No. 14/090,750.
- USPTO; Advisory Action dated Jan. 30, 2018 in U.S. Appl. No. 14/090,750.
- USPTO; Advisory Action dated Feb. 20, 2015 in U.S. Appl. No. 14/183,187.
- USPTO; Notice of Allowance dated Aug. 31, 2015 in U.S. Appl. No. 14/183,187.
- USPTO; Requirement for Restriction dated Sep. 24, 2015 in U.S. Appl. No. 14/188,760.
- USPTO; Advisory Action dated Jan. 12, 2017 in U.S. Appl. No. 14/188,760.
- USPTO; Advisory Action dated Jan. 3, 2018 in U.S. Appl. No. 14/188,760.
- USPTO; Advisory Action dated Apr. 29, 2016 in U.S. Appl. No. 14/218,374.
- USPTO; Notice of Allowance dated Aug. 5, 2016 in U.S. Appl. No. 14/218,374.
- USPTO; Advisory Action dated Jun. 30, 2016 in U.S. Appl. No. 14/219,839.
- USPTO; Final Office action dated May 19, 2016 in U.S. Appl. No. 14/219,879.
- USPTO; Advisory Action dated Aug. 22, 2016 in U.S. Appl. No. 14/219,879.
- USPTO; Final Office action dated Jul. 6, 2017 in U.S. Appl. No. 14/219,879.
- USPTO; Advisory Action dated Aug. 2, 2016 in U.S. Appl. No. 14/246,969.
- USPTO; Notice of Allowance dated Feb. 27, 2017 in U.S. Appl. No. 14/246,969.
- USPTO; Requirement for Restriction dated Jun. 15, 2015 in U.S. Appl. No. 14/268,348.
- USPTO; Notice of Allowance dated Aug. 30, 2016 in U.S. Appl. No. 14/268,348.
- USPTO; Requirement for Restriction dated May 21, 2015 in U.S. Appl. No. 14/281,477.
- USPTO; Advisory Action dated Mar. 28, 2016 in U.S. Appl. No. 14/281,477.
- USPTO; Non-Final Office Action dated Jul. 27, 2018 in U.S. Appl. No. 14/444,744.
- USPTO; Notice of Allowance dated Nov. 28, 2016 in U.S. Appl. No. 14/449,838.
- USPTO; Advisory Action dated Sep. 21, 2016 in U.S. Appl. No. 14/457,058.
- USPTO; Final Office Action dated Jun. 14, 2018 in U.S. Appl. No. 14/457,058.
- USPTO; Requirement for Restriction dated Sep. 3, 2015 in U.S. Appl. No. 14/498,036.
- USPTO; Advisory Action dated Jun. 16, 2016 in U.S. Appl. No. 14/498,036.
- USPTO; Notice of Allowance dated Aug. 17, 2016 in U.S. Appl. No. 14/498,036.
- USPTO; Requirement for Restriction dated Mar. 20, 2015 in U.S. Appl. No. 14/505,290.
- USPTO; Advisory Action dated Aug. 17, 2016 in U.S. Appl. No. 14/508,296.
- USPTO; Notice of Allowance dated Jan. 27, 2017 in U.S. Appl. No. 14/508,296.
- USPTO; Advisory Action dated Dec. 21, 2016 in U.S. Appl. No. 14/568,647.
- USPTO; Advisory Action dated Apr. 12, 2018 in U.S. Appl. No. 14/568,647.
- USPTO; Notice of Allowance dated May 18, 2016 in U.S. Appl. No. 14/571,126.
- USPTO; Restriction Requirement dated Mar. 7, 2016 in U.S. Appl. No. 14/606,364.
- USPTO; Final Office Action dated Jun. 14, 2016 in U.S. Appl. No. 14/606,364.
- USPTO; Advisory Action dated Aug. 25, 2016 in U.S. Appl. No. 14/606,364.
- USPTO; Non-Final Office Action dated Sep. 27, 2016 in U.S. Appl. No. 14/606,364.
- USPTO; Notice of Allowance dated Aug. 2, 2016 in U.S. Appl. No. 14/622,603.
- USPTO; Notice of Allowance dated Feb. 16, 2016 in U.S. Appl. No. 14/634,342.
- USPTO; Final Office Action dated Aug. 10, 2018 in U.S. Appl. No. 14/645,234.
- USPTO; Requirement for Restriction dated Oct. 26, 2015 in U.S. Appl. No. 14/659,152.
- USPTO; Non-Final Office Action dated Aug. 10, 2018 in U.S. Appl. No. 14/793,323.
- USPTO; Notice of Allowance dated Jun. 27, 2018 in U.S. Appl. No. 14/808,979.
- USPTO; Notice of Allowance dated Jul. 11, 2018 in U.S. Appl. No. 14/817,953.
- USPTO; Requirement for Restriction dated Mar. 17, 2016 in U.S. Appl. No. 14/827,177.
- USPTO; Notice of Allowance dated Jan. 27, 2017 in U.S. Appl. No. 14/827,177.
- USPTO; Requirement for Restriction dated Aug. 8, 2016 in U.S. Appl. No. 14/829,565.
- USPTO; Advisory Action dated Apr. 20, 2017 in U.S. Appl. No. 14/829,565.
- USPTO; Advisory Action dated Feb. 14, 2017 in U.S. Appl. No. 14/835,637.
- USPTO; Notice of Allowance dated Apr. 25, 2017 in U.S. Appl. No. 14/835,637.
- USPTO; Final Office Action dated Feb. 9, 2017 in U.S. Appl. No. 14/884,695.
- USPTO; Advisory Action dated Apr. 20, 2017 in U.S. Appl. No. 14/884,695.
- USPTO; Non-Final Office Action dated May 18, 2017 in U.S. Appl. No. 14/884,695.
- USPTO; Requirement for Restriction dated Dec. 1, 2016 in U.S. Appl. No. 14/886,571.
- USPTO; Final Office Action dated Sep. 21, 2017 in U.S. Appl. No. 14/886,571.
- USPTO; Notice of Allowance dated Dec. 6, 2017 in U.S. Appl. No. 14/886,571.
- USPTO; Requirement for Restriction dated Sep. 20, 2016 in U.S. Appl. No. 14/919,536.
- USPTO; Non-Final Office Action dated May 3, 2016 in U.S. Appl. No. 14/937,053.
- USPTO; Notice of Allowance dated Jul. 26, 2016 in U.S. Appl. No. 14/937,053.
- USPTO; Requirement for Restriction dated Sep. 15, 2016 in U.S. Appl. No. 14/938,180.
- USPTO; Notice of Allowance dated Nov. 21, 2016 in U.S. Appl. No. 14/981,434.
- USPTO; Notice of Allowance dated Jun. 7, 2017 in U.S. Appl. No. 14/981,468.
- USPTO; Non-Final Office Action dated Jun. 20, 2018 in U.S. Appl. No. 14/997,683.
- USPTO; Non-Final Office Action dated Apr. 22, 2016 in U.S. Appl. No. 15/055,122.
- USPTO; Notice of Allowance dated Sep. 15, 2016 in U.S. Appl. No. 15/055,122.
- USPTO; Requirement for Restriction dated Jun. 28, 2018 in U.S. Appl. No. 15/074,813.
- USPTO; Notice of Allowance dated Jun. 29, 2018 in U.S. Appl. No. 15/135,224.
- USPTO; Final Office Action dated Jul. 6, 2018 in U.S. Appl. No. 15/135,258.
- USPTO; Final Office Action dated Jul. 26, 2018 in U.S. Appl. No. 15/144,506.

(56)

References Cited

OTHER PUBLICATIONS

USPTO; Requirement for Restriction dated Jun. 22, 2018 in U.S. Appl. No. 15/182,504.
USPTO; Advisory Action dated Aug. 23, 2017 in U.S. Appl. No. 15/203,632.
USPTO; Requirement for Restriction dated Jan. 26, 2017 in U.S. Appl. No. 15/205,890.
USPTO; Requirement for Restriction dated Apr. 3, 2017 in U.S. Appl. No. 15/222,715.
USPTO; Notice of Allowance dated Jul. 14, 2017 in U.S. Appl. No. 15/222,715.
USPTO; Notice of Allowance dated Sep. 27, 2017 in U.S. Appl. No. 15/222,715.
USPTO; Notice of Allowance dated Feb. 3, 2017 in U.S. Appl. No. 15/222,738.
USPTO; Notice of Allowance dated Aug. 23, 2017 in U.S. Appl. No. 15/222,738.
USPTO; Requirement for Restriction dated Dec. 5, 2017 in U.S. Appl. No. 15/254,605.
USPTO; Notice of Allowance dated Jul. 12, 2018 in U.S. Appl. No. 15/254,605.
USPTO; Notice of Allowance dated Apr. 2, 2018 in U.S. Appl. No. 15/254,724.
USPTO; Non-Final Office Action dated Aug. 3, 2018 in U.S. Appl. No. 15/273,488.
USPTO; Non-Final Office Action dated Jul. 2, 2018 in U.S. Appl. No. 15/286,503.
USPTO; Requirement for Restriction dated Sep. 12, 2017 in U.S. Appl. No. 15/377,439.
USPTO; Advisory Action dated Aug. 8, 2018 in U.S. Appl. No. 15/377,439.
USPTO; Notice of Allowance dated Oct. 11, 2017 in U.S. Appl. No. 15/380,895.
USPTO; Requirement for Restriction dated Sep. 21, 2017 in U.S. Appl. No. 15/380,921.
USPTO; Final Office Action dated Jun. 28, 2018 in U.S. Appl. No. 15/380,921.
USPTO; Final Office Action dated May 15, 2018 in U.S. Appl. No. 15/388,410.
USPTO; Notice of Allowance dated Dec. 22, 2017 in U.S. Appl. No. 15/397,237.
USPTO; Non-Final Office Action dated Aug. 7, 2018 in U.S. Appl. No. 15/428,808.
USPTO; Notice of Allowance dated Apr. 20, 2018 in U.S. Appl. No. 15/466,149.
USPTO; Non-Final Office Action dated Apr. 6, 2018 in U.S. Appl. No. 15/472,750.
USPTO; Notice of Allowance dated Mar. 21, 2018 in U.S. Appl. No. 15/476,035.
USPTO; Notice of Allowance dated Aug. 14, 2018 in U.S. Appl. No. 15/476,035.
USPTO; Notice of Allowance dated Dec. 19, 2017 in U.S. Appl. No. 15/489,660.
USPTO; Notice of Allowance dated May 23, 2018 in U.S. Appl. No. 15/499,647.
USPTO; Non-Final Office Action dated Jun. 21, 2018 in U.S. Appl. No. 15/499,647.
USPTO; Requirement of Restriction dated Mar. 30, 2018 in U.S. Appl. No. 15/589,849.
USPTO; Office Action dated Aug. 30, 2018 in U.S. Appl. No. 15/589,849.
USPTO; Office Action dated May 3, 2018 in U.S. Appl. No. 15/589,861.
USPTO; Requirement for Restriction dated Aug. 1, 2018 in U.S. Appl. No. 15/627,189.
USPTO; Non-Final Office Action dated Jun. 5, 2018 in U.S. Appl. No. 15/650,686.
USPTO; Requirement for Restriction dated Apr. 6, 2018 in U.S. Appl. No. 15/659,631.

USPTO; Non-Final Office Action dated Aug. 9, 2018 in U.S. Appl. No. 15/660,805.
USPTO; Non-Final Office Action dated Jul. 27, 2018 in U.S. Appl. No. 15/673,110.
USPTO; Final Office Action dated Aug. 24, 2018 in U.S. Appl. No. 15/683,701.
USPTO; Non-Final Office Action dated Aug. 9, 2018 in U.S. Appl. No. 15/691,241.
USPTO; Requirement for Restriction dated Jul. 11, 2018 in U.S. Appl. No. 15/707,786.
USPTO; Non-Final Office Action dated May 17, 2018 in U.S. Appl. No. 15/729,485.
USPTO; Non-Final Office Action dated Jun. 26, 2018 in U.S. Appl. No. 15/796,593.
USPTO; Notice of Allowance dated Jun. 13, 2018 in U.S. Appl. No. 15/798,120.
USPTO; Non-Final Office Action dated Aug. 9, 2018 in U.S. Appl. No. 15/798,201.
USPTO; Non-Final Office Action dated Jul. 2, 2018 in U.S. Appl. No. 15/815,483.
USPTO; Requirement for Restriction dated Mar. 21, 2018 in U.S. Appl. No. 15/863,340.
USPTO; Non-Final Office Action dated Jul. 23, 2018 in U.S. Appl. No. 15/863,340.
USPTO; Notice of Allowance dated May 14, 2012 in U.S. Appl. No. 29/411,637.
USPTO; Notice of Allowance dated Oct. 2, 2013 in U.S. Appl. No. 29/412,887.
USPTO; Notice of Allowance dated Dec. 19, 2013 in U.S. Appl. No. 29/448,094.
USPTO; Requirement for Restriction dated Dec. 1, 2014 in U.S. Appl. No. 29/481,312.
USPTO; Requirement for Restriction dated Dec. 4, 2014 in U.S. Appl. No. 29/481,315.
USPTO; Notice of Allowance dated Jun. 26, 2018 in U.S. Appl. No. 29/604,288.
Chinese Patent Office; Office Action dated Aug. 1, 2013 in Application No. 201080015699.9.
Chinese Patent Office; Office Action dated Jan. 21, 2014 in Application No. 201080015699.9.
Chinese Patent Office; Office Action dated Jul. 24, 2014 in Application No. 201080015699.9.
Chinese Patent Office; Office Action dated Dec. 10, 2013 in Application No. 201080020267.7.
Chinese Patent Office; Office Action dated Jan. 21, 2013 in Application No. 201080020268.1.
Chinese Patent Office; Office Action dated Sep. 26, 2013 in Application No. 201080020268.1.
Chinese Patent Office; Office Action dated Apr. 3, 2014 in Application No. 201080020268.1.
Chinese Patent Office; Office Action dated Sep. 23, 2014 in Application No. 201080020268.1.
Chinese Patent Office; Office Action dated Apr. 7, 2015 in Application No. 201080020268.1.
Chinese Patent Office; Office Action dated Dec. 4, 2015 in Application No. 201210201995.9.
Chinese Patent Office; Office Action dated Jul. 14, 2016 in Application No. 201210201995.9.
Chinese Patent Office; Office Action dated Jan. 20, 2017 in Application No. 201210201995.9.
Chinese Patent Office; Office Action dated Dec. 24, 2015 in Application No. 201280057466.4.
Chinese Patent Office; Office Action dated Dec. 4, 2015 in Application No. 201280057542.1.
Chinese Patent Office; Office Action dated May 16, 2016 in Application No. 201280057542.1.
Chinese Patent Office; Office Action dated Sep. 9, 2016 in Application No. 201280057542.1.
Chinese Patent Office; Office Action dated Dec. 5, 2016 in Application No. 201310412808.6.
Chinese Patent Office; Office Action dated Feb. 5, 2018 in Application No. 201410331047.6.

(56)

References Cited

OTHER PUBLICATIONS

European Patent Office; Supplementary European Search Report and Opinion dated Nov. 9, 2012 in Application No. 08798519.8.
European Patent Office; Office Action dated Jul. 18, 2016 in Application No. 08798519.8.
European Patent Office; Extended European Search Report dated Dec. 9, 2016 in Application No. 9767208.3.
European Patent Office; Supplementary European Search Report and Opinion dated Jan. 5, 2017 in Application No. 09836647.9.
European Patent Office; Office Action dated Feb. 28, 2018 in Application No. 09836647.9.
Japanese Patent Office; Office Action dated Dec. 20, 2011 in Application No. 2010-522075.
Japanese Patent Office; Office Action dated Apr. 11, 2012 in Application No. 2010-522075.
Japanese Patent Office; Office Action dated May 31, 2012 in Application No. 2011-514650.
Japanese Patent Office; Office Action dated Sep. 11, 2012 in Application No. 2011-514650.
Japanese Patent Office; Office Action dated Dec. 25, 2013 in Application No. 2012-504786.
Japanese Patent Office; Office Action dated Mar. 11, 2013 in Application No. 2012-509857.
Korean Patent Office; Final Office Action dated Jun. 29, 2016 in Application No. 10-2010-0028336.
Korean Patent Office; Office Action dated Mar. 3, 2016 in Application No. 10-2010-0067768.
Korean Patent Office; Office Action dated Aug. 1, 2016 in Application No. 10-2010-0067768.
Korean Patent Office; Office Action dated May 2, 2016 in Application No. 10-2010-0082446.
Korean Patent Office; Office Action dated Sep. 19, 2016 in Application No. 10-2010-0082446.
Korean Patent Office; Office Action dated Nov. 24, 2017 in Application No. 10-20110036449.
Korean Patent Office; Office Action dated May 23, 2017 in Application No. 10-20110036449.
Korean Patent Office; Office Action dated Dec. 11, 2015 in Application No. 10-20117023416.
Korean Patent Office; Office Action dated Mar. 13, 2016 in Application No. 10-20117023416.
Korean Patent Office; Office Action dated Sep. 4, 2017 in Application No. 10-2011-0087600.
Korean Patent Office; Office Action dated Oct. 23, 2017 in Application No. 10-2011-0142924.
Korean Patent Office; Office Action dated Oct. 30, 2017 in Application No. 10-2012-0041878.
Korean Patent Office; Office Action dated Mar. 21, 2018 in Application No. 10-20120042518.
Korean Patent Office; Office Action dated Mar. 21, 2018 in Application No. 10-2012-0064526.
Korean Patent Office; Office Action dated Mar. 30, 2018 in Application No. 10-2012-0076564.
Korean Patent Office; Office Action dated Apr. 30, 2018 in Application No. 10-2012-0103114.
Korean Patent Office; Office Action dated Oct. 24, 2016 in Application No. 10-20127004062.
Korean Patent Office; Office Action dated Jul. 24, 2017 in Application No. 10-20127004062.
Korean Patent Office; Office Action dated Sep. 28, 2017 in Application No. 10-20147017112.
Korean Patent Office; Office Action dated Nov. 9, 2016 in Application No. 10-20167023913.
Korean Patent Office; Office Action dated Sep. 15, 2017 in Application No. 30-2017-0001320.
Korean Patent Office; Office Action dated Jul. 11, 2018 in Application No. 30-2018-006016.
Taiwanese Patent Office; Office Action dated Aug. 30, 2013 in Application No. 97132391.

Taiwanese Patent Office; Office Action dated Dec. 20, 2013 in Application No. 98117513.
Taiwanese Patent Office; Office Action dated Aug. 27, 2014 in Application No. 99114329.
Taiwanese Patent Office; Office Action dated Dec. 26, 2014 in Application No. 99114330.
Taiwanese Patent Office; Office Action dated Aug. 14, 2014 in Application No. 99114331.
Taiwanese Patent Office; Office Action received in Application No. 100113130.
Taiwanese Patent Office; Office Action dated Aug. 1, 2016 in Application No. 101124745.
Taiwanese Patent Office; Office Action received in Application No. 102113028.
Taiwanese Patent Office; Office Action received in Application No. 102115605.
Taiwanese Patent Office; Office Action dated Feb. 24, 2017 in Application No. 102115605.
Taiwanese Patent Office; Office Action received in Application No. 102125191.
Taiwanese Patent Office; Office Action dated Dec. 6, 2016 in Application No. 102126071.
Taiwanese Patent Office; Office Action dated May 17, 2018 in Application No. 102126071.
Taiwanese Patent Office; Office Action dated Feb. 10, 2017 in Application No. 102127065.
Taiwanese Patent Office; Office Action dated Mar. 11, 2016 in Application No. 102129262.
Taiwanese Patent Office; Office Action dated Dec. 29, 2016 in Application No. 102129397.
Taiwanese Patent Office; Office Action dated Nov. 4, 2016 in Application No. 102131839.
Taiwanese Patent Office; Office Action dated Nov. 11, 2016 in Application No. 102132952.
Taiwanese Patent Office; Office Action dated Dec. 2, 2016 in Application No. 102136496.
Taiwanese Patent Office; Office Action dated Jan. 10, 2018 in Application No. 102136496.
Taiwanese Patent Office; Office Action dated Jul. 17, 2017 in Application No. 103101400.
Taiwanese Patent Office; Office Action dated Feb. 23, 2017 in Application No. 103102563.
Taiwanese Patent Office; Office Action dated Mar. 3, 2017 in Application No. 103105251.
Taiwanese Patent Office; Office Action received in Application No. 103106021.
Taiwanese Patent Office; Office Action dated Oct. 31, 2017 in Application No. 103106022.
Taiwanese Patent Office; Office Action dated Jul. 5, 2017 in Application No. 103117477.
Taiwanese Patent Office; Office Action dated Nov. 22, 2017 in Application No. 103117478.
Taiwanese Patent Office; Office Action dated May 19, 2017 in Application No. 103120478.
Taiwanese Patent Office; Office Action dated Nov. 8, 2017 in Application No. 103124509.
Taiwanese Patent Office; Office Action dated Nov. 20, 2017 in Application No. 103127588.
Taiwanese Patent Office; Office Action dated Sep. 19, 2017 in Application No. 103127734.
Taiwanese Patent Office; Office Action dated Nov. 22, 2017 in Application No. 103134537.
Taiwanese Patent Office; Office Action dated Aug. 24, 2017 in Application No. 103136251.
Taiwanese Patent Office; Office Action dated Feb. 26, 2018 in Application No. 103138510.
Taiwanese Patent Office; Office Action dated May 21, 2018 in Application No. 103139014.
Taiwanese Patent Office; Office Action dated Jun. 22, 2018 in Application No. 104105533.
Taiwanese Patent Office; Office Action dated Jun. 13, 2018 in Application No. 104111910.

(56)

References Cited

OTHER PUBLICATIONS

- Taiwanese Patent Office; Office Action received in Application No. 106117181.
- Guan et al., "Voltage gated ion and molecule transport in engineered nanochannels: theory, fabrication and applications," *Nanotechnology* 25 (2014) 122001.
- Hudis, "Surface Crosslinking of Polyethylene Using a Hydrogen Glow Discharge," *J. Appl. Polym. Sci.*, 16 (1972) 2397.
- Mix et al., "Characterization of plasma-polymerized allyl alcohol polymers and copolymers with styrene," *Adhes. Sci. Technol.*, 21 (2007), S. 487-507.
- USPTO; Notice of Allowance dated Jun. 28, 2017 in U.S. Appl. No. 13/166,367.
- USPTO; Non-Final Office Action dated Sep. 20, 2018 in U.S. Appl. No. 13/651,144.
- USPTO; Notice of Allowance dated Aug. 13, 2018 in U.S. Appl. No. 13/941,226.
- USPTO; Notice of Allowance dated Oct. 3, 2018 in U.S. Appl. No. 13/941,226.
- USPTO; Notice of Allowance dated Aug. 29, 2018 in U.S. Appl. No. 14/090,750.
- USPTO; Notice of Allowance dated Sep. 24, 2018 in U.S. Appl. No. 14/218,690.
- USPTO; Final Office Action dated Sep. 5, 2018 in U.S. Appl. No. 14/752,712.
- USPTO; Advisory Action dated Aug. 10, 2018 in U.S. Appl. No. 14/829,565.
- USPTO; Non-Final Office Action dated Sep. 6, 2018 in U.S. Appl. No. 14/829,565.
- USPTO; Notice of Allowance dated Oct. 20, 2017 in U.S. Appl. No. 14/884,695.
- USPTO; Notice of Allowance dated Oct. 4, 2018 in U.S. Appl. No. 14/919,536.
- USPTO; Non-Final Office Action dated Aug. 27, 2018 in U.S. Appl. No. 15/067,028.
- USPTO; Notice of Allowance dated Oct. 14, 2018 in U.S. Appl. No. 15/135,333.
- USPTO; Notice of Allowance dated May 22, 2017 in U.S. Appl. No. 15/222,738.
- USPTO; Notice of Allowance dated Sep. 10, 2018 in U.S. Appl. No. 15/222,749.
- USPTO; Non-Final Office Action dated Oct. 1, 2018 in U.S. Appl. No. 15/222,780.
- USPTO; Non-Final Office Action dated Sep. 13, 2018 in U.S. Appl. No. 15/262,990.
- USPTO; Non-Final Office Action dated Oct. 3, 2017 in U.S. Appl. No. 15/388,410.
- USPTO; Non-Final Office Action dated Sep. 20, 2018 in U.S. Appl. No. 15/410,503.
- USPTO; Final Office Action dated Aug. 29, 2018 in U.S. Appl. No. 15/434,051.
- USPTO; Non-Final Office Action dated Sep. 10, 2018 in U.S. Appl. No. 15/489,453.
- USPTO; Notice of Allowance dated Jul. 18, 2018 in U.S. Appl. No. 15/640,239.
- USPTO; Notice of Allowance dated Aug. 30, 2018 in U.S. Appl. No. 15/640,239.
- USPTO; Non-Final Office Action dated Sep. 21, 2017 in U.S. Appl. No. 15/659,631.
- USPTO; Non-Final Office Action dated Aug. 27, 2018 in U.S. Appl. No. 15/662,107.
- USPTO; Requirement for Restriction dated Sep. 11, 2018 in U.S. Appl. No. 15/672,063.
- USPTO; Requirement for Restriction dated Aug. 14, 2018 in U.S. Appl. No. 15/705,955.
- USPTO; Non-Final Office Action dated Oct. 4, 2018 in U.S. Appl. No. 15/726,222.
- USPTO; Restriction Requirement dated Aug. 31, 2018 in U.S. Appl. No. 15/795,056.
- USPTO; Non-Final Office Action dated Jun. 26, 2018 in U.S. Appl. No. 15/796,693.
- USPTO; Non-Final Office Action dated Sep. 10, 2018 in U.S. Appl. No. 15/836,547.
- European Patent Office; Office Action dated Aug. 10, 2018 in Application No. 09767208.3.
- Korean Patent Office; Office Action dated Apr. 2, 2018 in Application No. 10-2011-0036449.
- Korean Patent Office; Office Action dated Sep. 18, 2018 in Application No. 10-2012-0064526.
- Korean Patent Office; Office Action dated Sep. 27, 2018 in Application No. 10-2012-0076564.
- Korean Patent Office; Office Action dated Sep. 28, 2017 in Application No. 10-2017-7023740.
- Taiwanese Patent Office; Office Action dated Sep. 26, 2018 in Application No. 103132230.
- Taiwanese Patent Office; Office Action dated May 21, 2018 Application No. 103139014.
- Taiwanese Patent Office; Office Action dated Jul. 9, 2018 in Application No. 104107876.
- Taiwanese Patent Office; Office Action dated Aug. 7, 2018 Application No. 104107888.
- Taiwanese Patent Office; Office Action dated Jul. 9, 2018 in Application No. 104110326.
- Taiwanese Patent Office; Office Action dated Jul. 11, 2018 in Application No. 104124377.
- Taiwanese Patent Office; Office Action dated Jun. 25, 2018 in Application No. 106138800.
- Taiwanese Patent Office; Office Action dated Aug. 31, 2018 in Application No. 10720809210.
- WIPO; International Search Report and Written Opinion dated Jul. 9, 2018 in Application No. PCT/IB2018/000419.
- WIPO; International Search Report and Written Opinion dated Sep. 14, 2018 in Application No. PCT/IB2017/001640.
- Crystal IS "Application Note: Using UV Reflective Materials to Maximize Disinfection"; AN011; Jun. 16, 2016.
- Kukli et al., "Properties of hafnium oxide films grown by atomic layer deposition from hafnium tetraiodide and oxygen". *Journal of Applied Physics*, vol. 92, No. 10, Nov. 15, 2002, pp. 5698-5703.
- Liang et al. "Conversion of Metal Carbides to Carbide Derived Carbon by Reactive Ion Etching in Halogen Gas" *Micro (MEMS) and Nanotechnologies for Space Applications*, Thomas George et al. vol. 6223, 2006 pp. 62230J-I to 62230J-11 lines 3-14 in the "Abstract" section and lines 7-9 in the "Introduction" section of p. 1, lines 3-4 in the "Introduction" section and lines 3-4 in the "Experimental Procedure" section of p. 2.
- "Polyurethane HF"; webpage; no date. Cited in Notice of References dated May 18, 2017 in U.S. Appl. No. 14/884,695.
- Xu et al., "14NM Metal Gate Film Stack Development and Challenges," SMIC et al. (2016).
- EPO; Extended European Search Report dated Apr. 28, 2014 in Application No. 11162225.4.
- EPO; Notice of Allowance dated Feb. 3, 2015 in Application No. 11162225.4.
- IPOS; Notice of Allowance dated Aug. 14, 2017 in Application No. 10201401237.
- JPO; Office Action dated Mar. 27, 2012 in Application No. 2009-532567.
- JPO; Notice of Allowance dated Jul. 31, 2012 in Application No. 2009-532567.
- JPO; Office Action dated May 9, 2013 in Application No. 2010058415.
- JPO; Office Action dated Nov. 5, 2013 in Application No. 2010058415.
- JPO; Office Action dated Aug. 29, 2014 in Application No. 2010058415.
- JPO; Notice of Allowance dated Dec. 24, 2014 in Application No. 2010058415.
- JPO; Office Action dated Aug. 26, 2013 in Application No. 2010-153754.
- JPO; Office Action dated Nov. 5, 2013 in Application No. 2010-193285.
- JPO; Notice of Allowance dated Apr. 2, 2013 in Application No. 2010-509478.
- JPO; Office Action dated Aug. 31, 2015 in Application No. 2011-284831.

(56)

References Cited

OTHER PUBLICATIONS

JPO; Notice of Allowance dated Mar. 9, 2016 in Application No. 2011-284831.
JPO; Notice of Allowance dated Dec. 21, 2012 in Application No. 2011-514650.
JPO; Office Action dated Dec. 15, 2014 in Application No. 2011090067.
JPO; Notice of Allowance dated May 1, 2015 in Application No. 2011090067.
JPO; Office Action dated Jul. 19, 2016 in Application No. 2012-153698.
JPO; Notice of Allowance dated Oct. 26, 2016 in Application No. 2012-153698.
JPO; Notice of Allowance dated Jun. 12, 2015 in Application No. 2012-504786.
JPO; Notice of Allowance dated Jul. 2, 2013 in Application No. 2012-509857.
JPO; Office Action dated May 31, 2017 in Application No. 2013-160173.
JPO; Notice of Allowance dated Aug. 25, 2017 in Application No. 2013-160173.
JPO; Office Action dated Jun. 15, 2017 in Application No. 2013-178344.
JPO; Office Action dated Jan. 29, 2018 in Application No. 2013-178344.
JPO; Notice of Allowance dated Aug. 21, 2018 in Application No. 2013-178344.
JPO; Office Action dated Apr. 10, 2018 in Application No. 2014-120675.
JPO; Notice of Allowance dated Jun. 12, 2018 in Application No. 2014-120675.
JPO; Office Action dated Apr. 3, 2018 in Application No. 2014-188835.
JPO; Notice of Allowance dated Jun. 12, 2018 in Application No. 2014-88835.
JPO; Office Action dated May 8, 2018 in Application No. 2014-205548.
JPO; Notice of Allowance dated May 22, 2018 in Application No. 2014-216540.
JPO; Office Action dated Jul. 31, 2018 in Application No. 2015-034774.
KIPO; Notice of Allowance dated Sep. 29, 2016 in Application No. 10-2010-0028336.
KIPO; Notice of Allowance dated Dec. 1, 2016 in Application No. 10-2010-0067768.
KIPO; Notice of Allowance dated Mar. 7, 2017 in Application No. 10-2010-0082446.
KIPO; Office Action dated Mar. 13, 2017 in Application No. 20110034612.
KIPO; Office Action dated Jul. 20, 2017 in Application No. 20110034612.
KIPO; Notice of Allowance dated Sep. 1, 2017 in Application No. 20110034612.
KIPO; Notice of Allowance dated Oct. 24, 2018 in Application No. 10-2011-0036449.
KIPO; Notice of Allowance dated Jan. 11, 2018 in Application No. 10-2011-0087600.
KIPO; Notice of Allowance dated Mar. 14, 2018 in Application No. 10-2011-0142924.
KIPO; Notice of Allowance dated Jun. 2, 2016 in Application No. 10-2011-7023416.
KIPO; Notice of Allowance dated Feb. 28, 2018 in Application No. 10-2012-0041878.
KIPO; Notice of Allowance dated May 30, 2018 in Application No. 10-2012-0042518.
KIPO; Office Action dated Dec. 13, 2018 in Application No. 10-2012-0064526.
KIPO; Notice of Allowance dated Nov. 22, 2018 in Application No. 10-2012-0103114.
KIPO; Notice of Allowance dated Feb. 23, 2018 in Application No. 10-2014-7017112.

KIPO; Notice of Allowance dated May 30, 2017 in Application No. 10-2016-7023913.
KIPO; Notice of Allowance dated Feb. 27, 2018 in Application No. 10-2017-0175442.
KIPO; Notice of Allowance dated Jul. 19, 2018 in Application No. 20187013945.
KIPO; Notice of Allowance dated Jan. 19, 2018 in Application No. 30-2017-0001320.
KIPO; Notice of Allowance dated Jul. 1, 2018 in Application No. 30-2017-0052872.
KIPO; Notice of Allowance dated Oct. 16, 2018 in Application No. 30-2018-0006016.
SIPO; Notice of Allowance dated May 8, 2015 in Application No. 201080015699.9.
SIPO; Notice of Allowance dated Aug. 22, 2014 in Application No. 201080020267.7.
SIPO; Notice of Allowance dated Oct. 16, 2015 in Application No. 201080020268.1.
SIPO; Notice of Allowance dated Oct. 24, 2014 in Application No. 201080036764.6.
SIPO; Notice of Allowance dated Aug. 26, 2015 in Application No. 201110155056.
SIPO; Notice of Allowance dated Apr. 13, 2017 in Application No. 201210201995.9.
SIPO; Notice of Allowance dated Jun. 16, 2016 in Application No. 201280057466.4.
SIPO; Notice of Allowance dated Jan. 3, 2017 in Application No. 201280057542.1.
SIPO; Notice of Allowance dated Jul. 20, 2017 in Application No. 201310412808.6.
SIPO; Notice of Allowance dated May 25, 2017 in Application No. 201730010308.9.
SIPO; Notice of Allowance dated Oct. 24, 2018 in Application No. 201830060972.9.
TIPO; Notice of Allowance dated Jun. 12, 2014 in Application No. 98117513.
TIPO; Notice of Allowance dated Feb. 24, 2016 in Application No. 99110511.
TIPO; Notice of Allowance dated Apr. 28, 2015 in Application No. 99114330.
TIPO; Notice of Allowance dated Oct. 16, 2015 in Application No. 99114331.
TIPO; Notice of Allowance dated Mar. 14, 2016 in Application No. 99127063.
TIPO; Notice of Allowance dated Jun. 29, 2016 in Application No. 100113130.
TIPO; Notice of Allowance dated Oct. 14, 2015 in Application No. 100130472.
TIPO; Notice of Allowance dated Oct. 19, 2016 in Application No. 101124745.
TIPO; Notice of Allowance dated Nov. 2, 2016 in Application No. 101142581.
TIPO; Notice of Allowance dated Sep. 9, 2016 in Application No. 101142582.
TIPO; Notice of Allowance dated Feb. 13, 2017 in Application No. 102113028.
TIPO; Notice of Allowance dated Dec. 26, 2017 in Application No. 102115605.
TIPO; Notice of Allowance dated May 3, 2017 in Application No. 102129262.
TIPO; Notice of Allowance dated Aug. 24, 2018 in Application No. 102126071.
TIPO; Notice of Allowance dated Jul. 18, 2017 in Application No. 102127065.
TIPO; Notice of Allowance dated Aug. 29, 2017 in Application No. 102129397.
TIPO; Notice of Allowance dated Jan. 26, 2017 in Application No. 102131839.
TIPO; Notice of Allowance dated Apr. 19, 2017 in Application No. 102132952.
TIPO; Notice of Allowance dated Jan. 24, 2018 in Application No. 103101400.

(56)

References Cited

OTHER PUBLICATIONS

- TIPO; Notice of Allowance dated Nov. 30, 2017 in Application No. 103102563.
- TIPO; Notice of Allowance dated Oct. 20, 2017 in Application No. 103105251.
- TIPO; Notice of Allowance dated Apr. 10, 2018 in Application No. 103106021.
- TIPO; Notice of Allowance dated Apr. 10, 2018 in Application No. 103106022.
- TIPO; Notice of Allowance dated Jan. 22, 2018 in Application No. 103117477.
- TIPO; Notice of Allowance dated Mar. 13, 2018 in Application No. 103117478.
- TIPO; Notice of Allowance dated Sep. 25, 2017 in Application No. 103120478.
- TIPO; Office Action dated Sep. 20, 2018 in Application No. 103123439.
- TIPO; Office Action dated Apr. 25, 2018 in Application No. 103124509.
- TIPO; Notice of Allowance dated Jun. 19, 2018 in Application No. 103127588.
- TIPO; Notice of Allowance dated Dec. 11, 2017 in Application No. 103127734.
- TIPO; Notice of Allowance dated Apr. 19, 2018 in Application No. 103134537.
- TIPO; Notice of Allowance dated Oct. 17, 2017 in Application No. 103136251.
- TIPO; Notice of Allowance dated Jun. 13, 2018 in Application No. 103138510.
- TIPO; Notice of Allowance dated Sep. 11, 2018 in Application No. 103139014.
- TIPO; Notice of Allowance dated Sep. 18, 2018 in Application No. 104111910.
- TIPO; Notice of Allowance dated Dec. 5, 2017 in Application No. 105308015.
- TIPO; Notice of Allowance dated Jun. 5, 2018 in Application No. 106117181.
- TIPO; Office Action dated Sep. 28, 2018 in Application No. 106119537.
- TIPO; Office Action dated Aug. 31, 2018 in Application No. 106138119.
- TIPO; Office Action dated Oct. 3, 2018 in Application No. 106142731.
- TIPO; Office Action dated Sep. 28, 2018 in Application No. 107112951.
- TIPO; Notice of Allowance dated Aug. 29, 2018 in Application No. 107300633.
- TIPO; Notice of Allowance dated Apr. 11, 2018 in Application No. 105308015D01.
- USPTO; Non-Final Office Action dated Feb. 15, 2012 in U.S. Appl. No. 13/085,531.
- USPTO; Notice of Allowance dated Jul. 12, 2012 in U.S. Appl. No. 13/085,531.
- USPTO; Final Office Action dated Nov. 2, 2018 in U.S. Appl. No. 13/169,951.
- USPTO; Final Office Action dated Nov. 1, 2018 in U.S. Appl. No. 14/219,839.
- USPTO; Final Office Action dated Nov. 2, 2018 in U.S. Appl. No. 14/219,879.
- USPTO; Final Office Action dated Nov. 28, 2018 in U.S. Appl. No. 14/508,489.
- USPTO; Notice of Allowance dated Nov. 19, 2018 in U.S. Appl. No. 14/656,588.
- USPTO; Notice of Allowance dated Nov. 19, 2018 in U.S. Appl. No. 14/919,536.
- USPTO; Final Office Action dated Dec. 10, 2018 in U.S. Appl. No. 14/997,683.
- USPTO; Final Office Action dated Oct. 19, 2018 in U.S. Appl. No. 15/060,412.
- USPTO; Non-Final Office Action dated Sep. 26, 2018 in U.S. Appl. No. 15/074,813.
- USPTO; Non-Final Office Action dated Nov. 23, 2018 in U.S. Appl. No. 15/135,258.
- USPTO; Non-Final Office Action dated Oct. 9, 2018 in U.S. Appl. No. 15/182,504.
- USPTO; Final Office Action dated Oct. 9, 2018 in U.S. Appl. No. 15/205,827.
- USPTO; Non-Final Office Action dated Nov. 14, 2018 in U.S. Appl. No. 15/377,439.
- USPTO; Notice of Allowance dated Nov. 14, 2018 in U.S. Appl. No. 15/388,410.
- USPTO; Notice of Allowance dated Dec. 28, 2018 in U.S. Appl. No. 15/388,410.
- USPTO; Restriction Requirement dated Dec. 5, 2018 in U.S. Appl. No. 15/402,993.
- USPTO; Advisory Action dated Dec. 4, 2018 in U.S. Appl. No. 15/434,051.
- USPTO; Notice of Allowance dated Nov. 30, 2018 in U.S. Appl. No. 15/472,750.
- USPTO; Notice of Allowance dated Nov. 1, 2018 in U.S. Appl. No. 15/499,647.
- USPTO; Notice of Allowance dated Nov. 15, 2018 in U.S. Appl. No. 15/499,647.
- USPTO; Final Office Action dated Nov. 16, 2018 in U.S. Appl. No. 15/592,730.
- USPTO; Restriction Requirement dated Oct. 10, 2018 in U.S. Appl. No. 15/615,489.
- USPTO; Non-Final Office Action dated Nov. 9, 2018 in U.S. Appl. No. 15/636,307.
- USPTO; Final Office Action dated Nov. 20, 2018 in U.S. Appl. No. 15/650,686.
- USPTO; Non-Final Office Action dated Dec. 4, 2018 in U.S. Appl. No. 15/672,063.
- USPTO; Restriction Requirement dated Oct. 15, 2018 in U.S. Appl. No. 15/672,119.
- USPTO; Advisory Action dated Nov. 26, 2018 in U.S. Appl. No. 15/683,701.
- USPTO; Non-Final Office Action dated Dec. 18, 2018 in U.S. Appl. No. 15/690,017.
- USPTO; Non-Final Office Action dated Dec. 6, 2018 in U.S. Appl. No. 15/705,955.
- USPTO; Notice of Allowance dated Dec. 6, 2018 in U.S. Appl. No. 15/711,989.
- USPTO; Final Office Action dated Dec. 13, 2018 in U.S. Appl. No. 15/719,208.
- USPTO; Final Office Action dated Nov. 14, 2018 in U.S. Appl. No. 15/726,959.
- USPTO; Non-Final Office Action dated Nov. 28, 2018 in U.S. Appl. No. 15/795,056.
- USPTO; Non-Final Office Action dated Sep. 26, 2018 in U.S. Appl. No. 15/832,188.
- USPTO; Notice of Allowance dated Dec. 10, 2018 in U.S. Appl. No. 15/863,340.
- USPTO; Restriction Requirement dated Dec. 13, 2018 in U.S. Appl. No. 15/886,225.
- USPTO; Non-Final Office Action dated Nov. 15, 2018 in U.S. Appl. No. 15/890,037.
- USPTO; Restriction Requirement dated Oct. 9, 2018 in U.S. Appl. No. 15/892,756.
- USPTO; Restriction Requirement dated Nov. 26, 2018 in U.S. Appl. No. 15/917,262.
- USPTO; Restriction Requirement dated Nov. 2, 2018 in U.S. Appl. No. 16/018,692.
- WIPO; International Search Report and Written Opinion dated Nov. 6, 2018 in Application No. PCT/IB2017/001652.
- Beynet et al. "Low temperature plasma-enhanced ALD enables cost-effective spacer defined double patterning." *Proceedings of SPIE*, 7520, (2009).
- Gupta et al., "Charge carrier transport and electroluminescence in atomic layer deposited poly-GaN/c-Si heterojunction diodes." *Journal of Applied Physics*, 124, 084503 (2018).

(56)

References Cited

OTHER PUBLICATIONS

MacKenzie et al. "Stress Control of Si-Based PEVCD Dielectrics,"
Proc. Symp. Silicon Nitride and Silicon Dioxide Thin Insulating
Films & Other Emerging Dielectrics VIII, 148-159 (2005).

* cited by examiner

FIG. 1

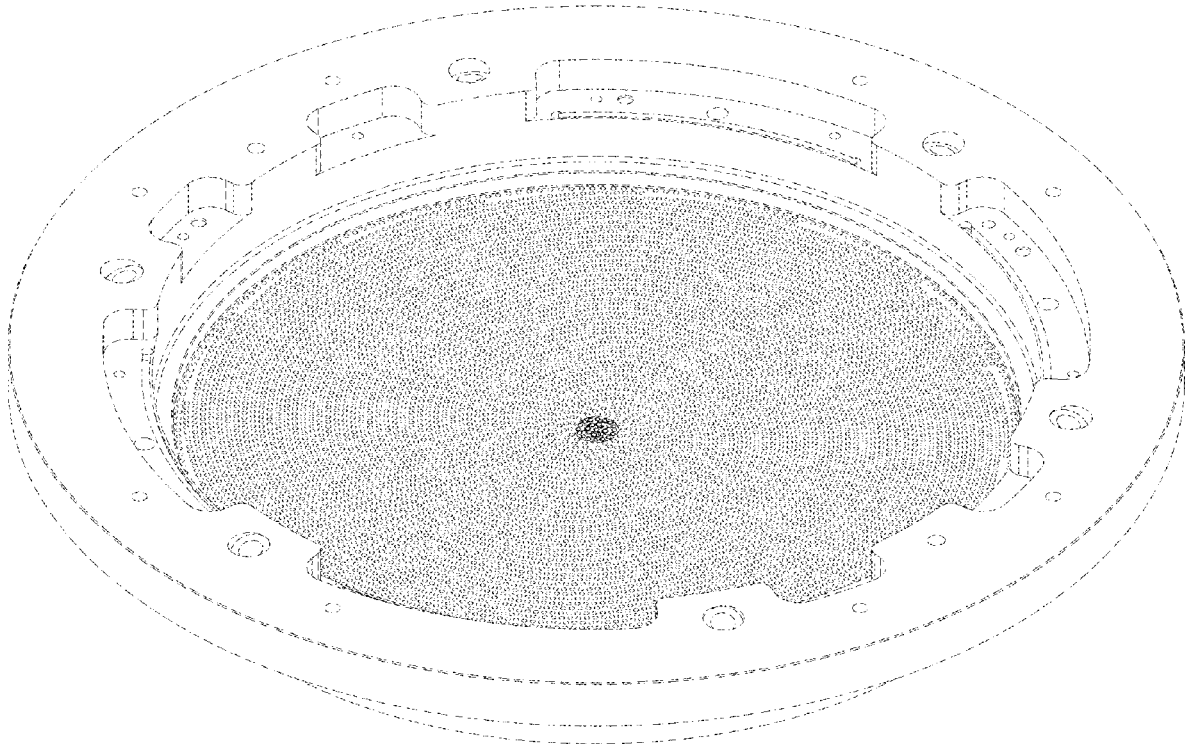

FIG. 2

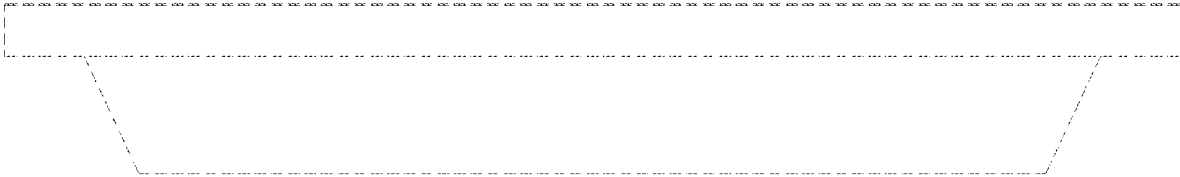

FIG. 3



FIG. 4

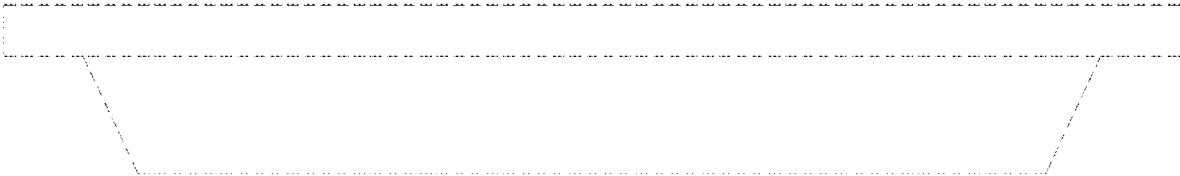

FIG. 5

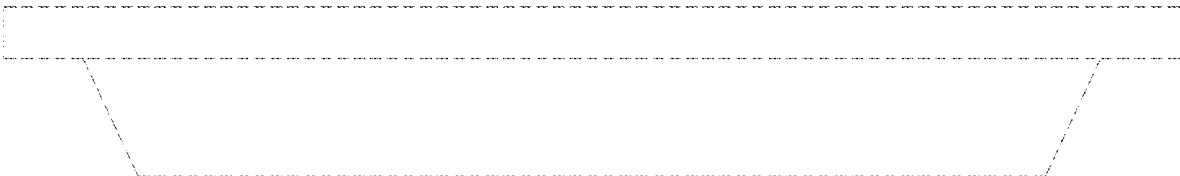

FIG. 6

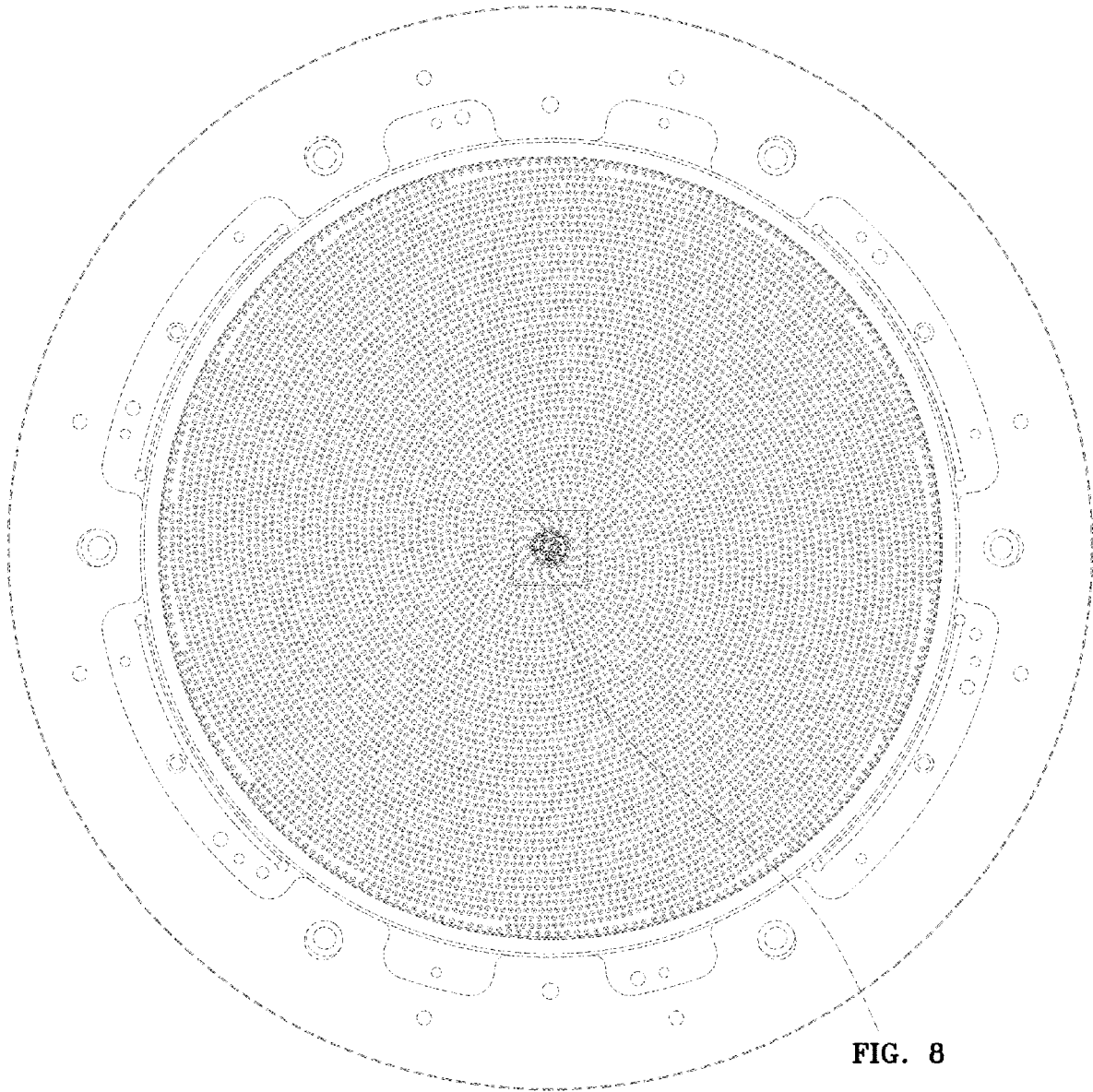

FIG. 8

FIG. 7

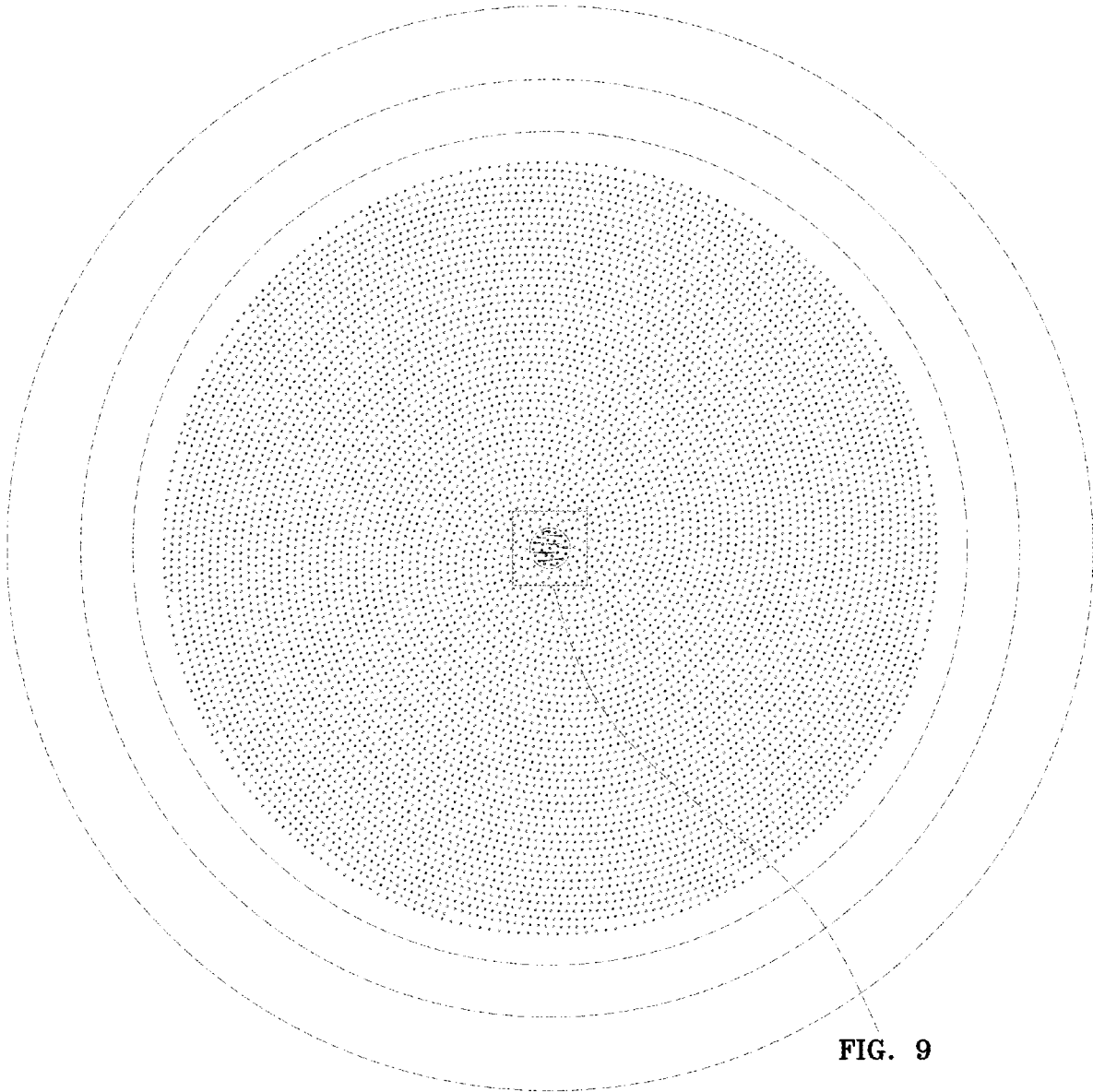

FIG. 9

FIG. 8

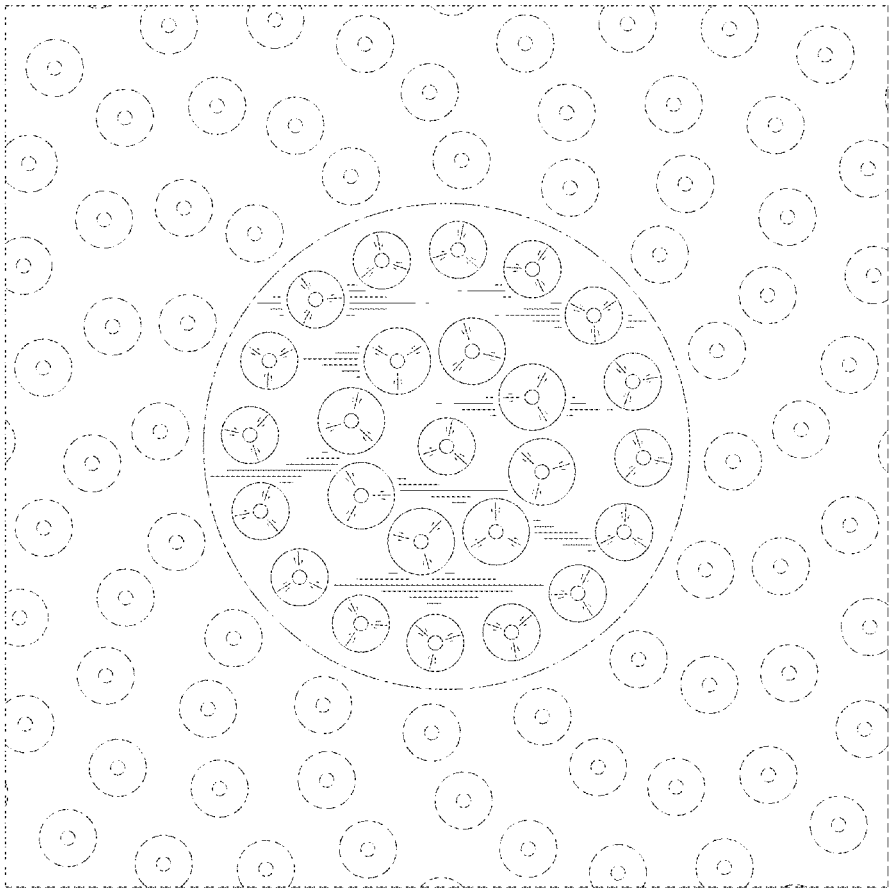

FIG. 9

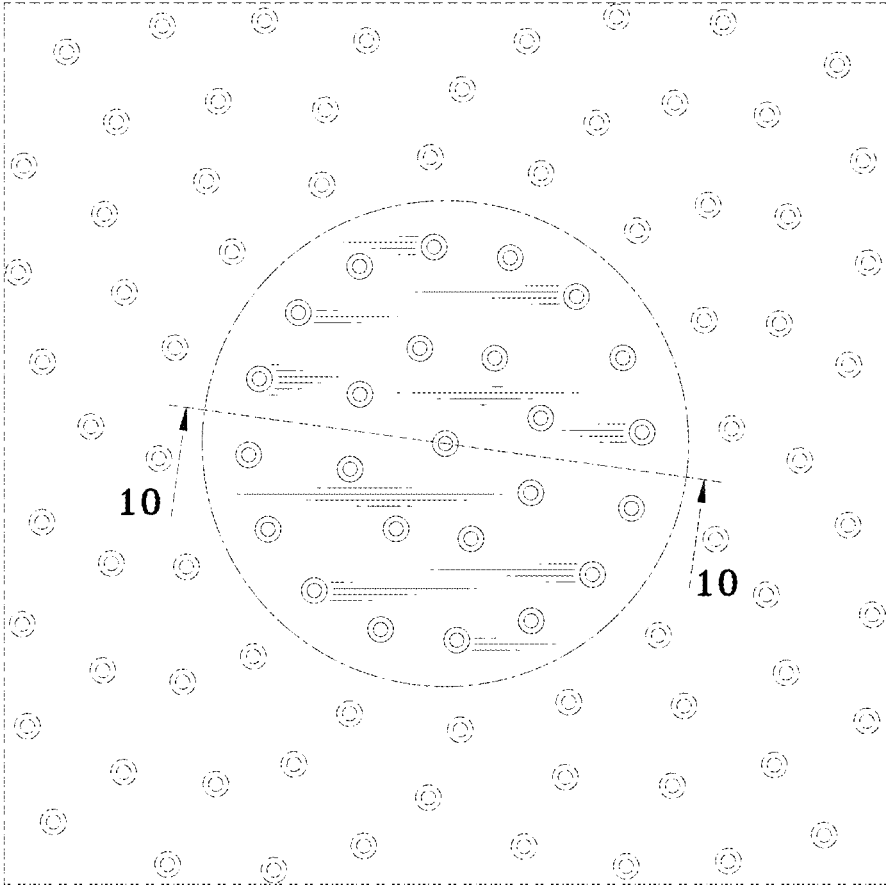

FIG. 10

