

(21) Application No 8001656

(22) Date of filing 17 Jan 1980

(30) Priority data

(31) 790191

(32) 19 Jan 1979

(33) Finland (FI)

(43) Application published  
20 Aug 1980

(51) INT CL<sup>3</sup>

A43B 21/28

(52) Domestic classification

A3B 7A1

(56) Documents cited

GB 1080926

GB 385060

GB 358205

(58) Field of search

A3B

(71) Applicant

Karhu-Titan OY

Töölöntullinkatu 8, 00250

Helsinki 25, Finland

(72) Inventor

Juha Viljanen

(74) Agent

Hans & Danielsson

(54) **A Footwear Multi-layer Sole**

(57) A sole 10 formed, on an upper 11 comprises an outsole 12, insole 13, and intermediate body 14. A hermetically sealed chamber in the body 14 is divided into compartments

15a and 16a by a divider 17a having a small aperture 18a to restrict air flow between the compartments and provide damped elastic yielding properties when the wearer's heel applies force on the insole 13 above the chamber.

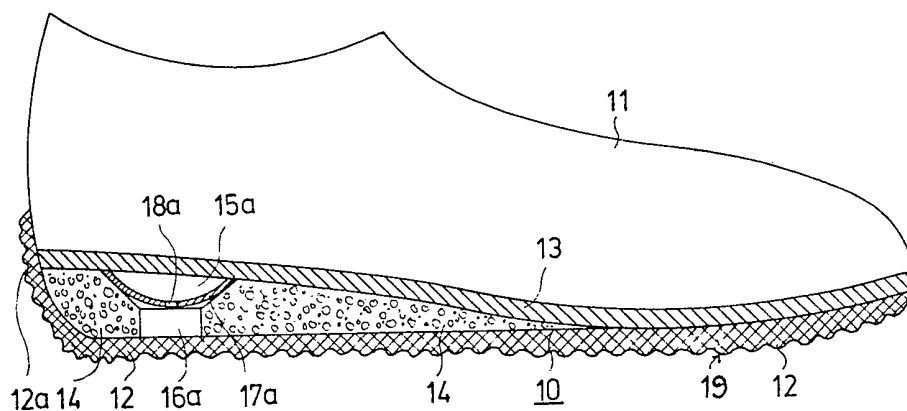

FIG. 1

1/1

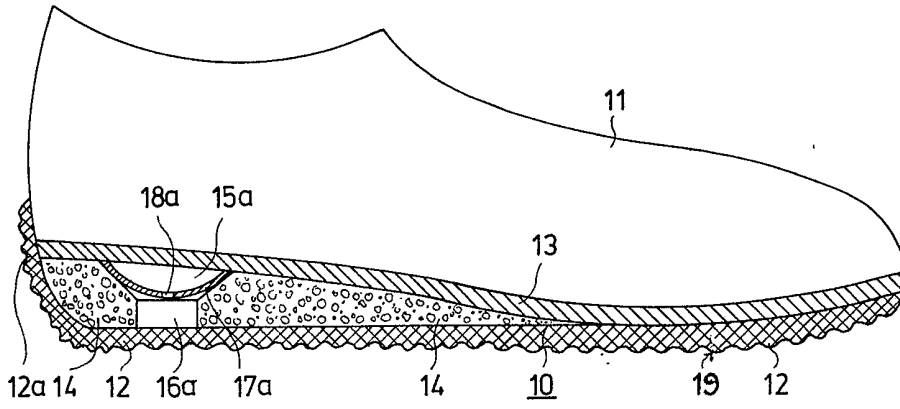

FIG. 1

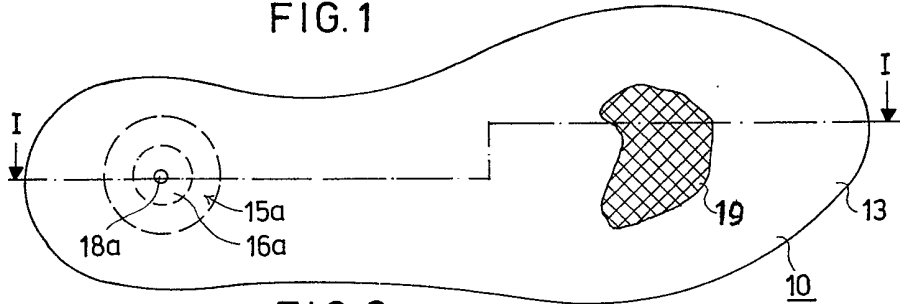

FIG. 2

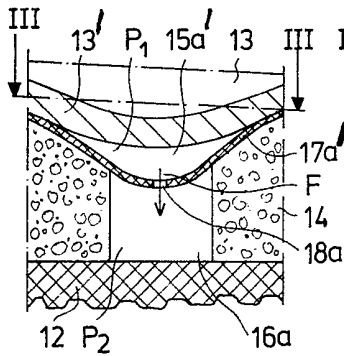

FIG. 3A

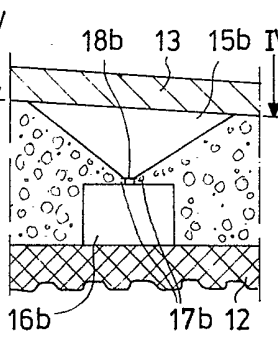

FIG. 4A

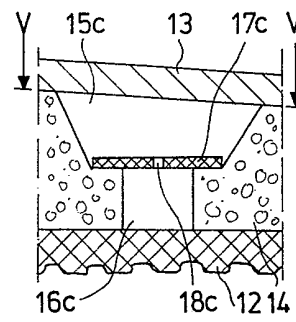

FIG. 5A

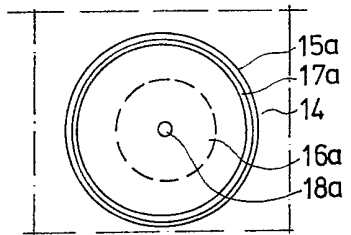

FIG. 3B

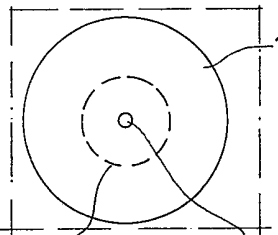

FIG. 4B

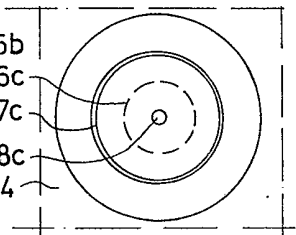

FIG. 5B

## SPECIFICATION

**A Footwear Multi-layer Sole**

This invention relates to a footwear multi-layer sole of the kind comprising at least an insole and an outsole and a wedge-shaped intermediate body in the heel region and between the insole and the outsole, there being in said body a hermetically enclosed chamber substantially where the wearer's heel exerts most pressure when the footwear is in use, the cross-section of the chamber diminishing from the top downwards.

The invention is envisaged as applicable more particularly but not exclusively to soles for sports shoes.

The usefulness of a sports shoe is largely determined by its sole structure, especially by the flexibility of the sole and by its ability to give uniform shock-free support to the wearer's foot.

The sole structures of some known sports shoes have the drawback that since the sole must be comparatively solid in the heel region, this has resulted in fairly marked inflexibility of the sole in this part, whereby it has become poorly adaptable to various foot shapes, this in its turn entailing detrimental loading effects which manifest themselves e.g. in the form of fallen arches and of a bone spike developing on the wearer's heel. Another detriment is painful toes, due to sliding of the foot towards the shoe tip, and sweaty feet.

For some prior proposals, reference may be made to German Patents No. 135,595 and 953,584, German Patent application texts No. 2,152,710 and 2,460,034, British Patents No. 1,010,519 and 1,018,098, Swedish Patents No. 890,045 and 116,298, Danish Patent No. 57,400, and U.S. Patents No. 2,741,038 and 4,102,061. The present invention is intended to develop further the sports shoe disclosed in U.S. Patent No. 4,102,061 putting to practical use such experiences as have been gained in practice. It has been found that in the sports shoe sole design of U.S. Patent No. 4,102,061 the yielding properties afforded by the cavity placed centrally under the heel may be too elastic and not sufficiently damped.

According to the present invention, a sole of the kind referred to is characterised in that the chamber is divided into an upper compartment and a lower compartment by a divider which allows restricted flow of air from the upper compartment to the lower compartment to provide damped elastic yielding properties of the sole when the wearer's heel applies force on the insole above the chamber and increases the pressure in the upper compartment.

How the invention may be put in practice is described in more detail with reference by way of example to the accompanying drawings, in which:—

Fig. 1 shows a shoe with a sole according to the invention, schematically, in section on the line I—I of Fig. 2,

Fig. 2 shows the sole of Fig. 1, viewed from the underside,

Fig. 3A shows a detail view in central vertical section, equivalent to Fig. 1, through the shoe sole at the heel, with the sole compressed

Fig. 3B shows a view in section on the line III—III of Fig. 3A,

Fig. 4A shows, in like manner as Figs. 3A, as modification,

Fig. 4B is a view in section on the line IV—IV of Fig. 4A,

Fig. 5A shows, in like manner as Figs. 3A and 4A, a further modification, and

Fig. 5B is a view in section on the line V—V of Fig. 5A.

Fig. 1 shows a shoe with a sole 10 moulded on to an upper 11. The sole 10 comprises an outsole 12, an insole 13, and a wedge-shaped intermediate body 14. The components 12, 13 and 14 consist of suitable rubber or plastics materials and they are affixed to each other, e.g. by moulding or cementing. The body 14 gives an appropriate shape to the sole 10. The components 12 and 13 may be substantially plate-like. The outsole 12 presents a relief-embossed wearing surface 19 and is extended into foxing strip 12a.

As shown in Figs. 1, 2, 3A and 3B, a hermetically enclosed chamber forms an air cavity disposed at the centre of the heel area, with an upper compartment 15a and a lower compartment 16a, shaped in the body 14, for example by boring. The compartments seal hermetically against the outsole 12 and against the elastic insole 13. The upper compartment 15a has the shape of an upwardly widening truncated cone, and the lower compartment 16a is substantially cylindrical. The shape of the upper compartment 15a endows the elastic inner sole 13 under the wearer's heel with suitable progressive elastic yielding characteristics, which are further improved by means of a divider 17a having in its centre a small-diameter flow aperture 18a.

The mode of operation of the elastic sports shoe sole of Figures 1 and 2 is described below, with reference to Figs. 3A and 3B. As shown in Fig. 3A, the elastic insole is in the position 13, indicated by dot-and-dash lines, when no load is acting on the shoe sole. When the shoe is pressed against the ground, the elastic insole 13 will yield elastically in the heel area, and to some extent also in the area of the arch, owing to the chamber. In this connection, at first, in the compartment 15a the pressure  $P_1$  rises to surpass the pressure  $P_2$  in the lower compartment 16a. The differential pressure  $\Delta P = P_1 - P_2$  tends to become equalized somewhat, owing to the elasticity of the divider 17a, but mostly as a result of the damping air flow  $F$  passing through the small-diameter hole 18a in the divider 17a.

Such flow  $F$  continues to pass until  $P_1 = P_2$ . In this manner, damped elastic yielding of the shoe sole in the heel area can be accomplished.

In Fig. 3A the inner sole 13 in its pushed-in extreme position is indicated with the reference numeral 13'. Similarly, the divider carries the reference 17a', and the compartments are indexed 15a' and 16a'. When the pressure of the wearer's heel against the insole ceases, the insole begins to rise towards the position 13, and then  $P_2 > P_1$  and the flow through the aperture 18a is in the direction opposite to the arrow F.

In Figures 4A and 4B the upper compartment 15b is conical, and the lower compartment 16b is cylindrical. At the apex of the conical compartment 15b is a small-diameter aperture 18b, which operates as has been described. This embodiment of the invention presents no separate diaphragm, but the divider 17b is formed by the annular part of the body 14 entering between the compartments 15b and 16b.

As shown in Figures 5A and 5B, the upper compartment 15c has the shape of a truncated cone and presents in its lower part a shoulder at the transition to the cylindrical lower compartment 16c. Upon said shoulder rests a substantially rigid cylindrical disk forming a divider 17c consisting e.g. of rubber, plastics material or metal, having in its centre a small-diameter hole 18c. The divider 17c operates like the divider 17a when the pressure is higher in the upper compartment. When the pressure in the lower compartment 16c is higher than the pressure in the upper compartment 15c, the disc divider 17c may rise and the said differential pressure is enabled to equalize very fast. In contrast, a differential pressure in the opposite direction is equalized only through the small-diameter aperture 18c in a delayed fashion, whereby the desired damped elastic yielding properties of the sole can be achieved.

In the sole of the invention, the shape of the upper compartment in combination with the damped elastic yielding properties can produce a sports shoe sole which is comfortable and advantageous.

Various modifications are possible, within the scope of the following claims, for example the disk divider 17c may be restrained to act like a disk or flap valve, and the dividers may be wholly or partly foraminous instead of having only one hole, and a metal plate or other stiffener may be arranged between the outsole 12 and the body 14 to prevent undue deflection of the outsole 12 or penetration of pointed articles into the chamber.

## Claims

- 55 1. A footwear multi-layer sole (10) of the kind comprising at least an insole (13) and an outsole (19) and a wedge-shaped intermediate body (14) in the heel region and between the insole (13) and the outsole (19), there being in said body (14) a hermetically enclosed chamber substantially where the wearer's heel exerts most pressure when the footwear is in use, the cross-section of the chamber diminishing from the top downwards, characterised in that the chamber is divided into an upper compartment (15a, 15b, 15c) and a lower compartment (16a, 16b, 16c) by a divider (17a, 17b, 17c) which allows restricted flow of air from the upper compartment (15a, 15b, 15c) to the lower compartment (16a, 16b, 16c) to provide damped elastic yielding properties of the sole (10) when the wearer's heel applies force on the insole (13) above the chamber and increases the pressure in the upper compartment (15a, 15b, 15c).
- 75 2. A sole according to Claim 1, wherein the upper compartment (15a, 15b, 15c) has the form of an inverted cone or conical frustum.
3. A sole according to Claim 1 or 2, wherein the divider (17a, 17b, 17c) has at least one aperture (18a, 18b, 18c) for the restricted flow of air.
- 80 4. A sole according to Claim 1, 2 or 3, wherein the divider (17a) is in the form of a resilient or elastic diaphragm.
- 85 5. A sole according to Claims 2 and 4, wherein the divider (17a) has the form of a dish with its greatest diameter substantially equal to and at the greatest diameter of the upper compartment (15a).
- 90 6. A sole according to Claim 1, 2, or 3, wherein the divider (17b) is constituted by some of the material of the said body (14).
7. A sole according to Claim 1, 2, or 3, wherein the divider (17c) is in the form of a substantially rigid disc.
- 95 8. A sole according to Claim 7, wherein the divider (17c) is movable and can rest on a shoulder formed in the said body (14).
9. A sole according to Claim 8, wherein the movement of the divider (17c) is restricted so that it acts like a disc valve.
- 100 10. A sole constructed and arranged substantially as hereinbefore described with reference to and as illustrated in Figures 1 to 3B, 4A and 4B, or 5A and 5B of the accompanying drawings.
- 105