

(21) Application No: 1209089.0
(22) Date of Filing: 24.05.2012

(51) INT CL: G06F 15/16 (2006.01) H05K 7/14 (2006.01)

(71) Applicant(s):
International Business Machines Corporation
(Incorporated in USA - New York)
New Orchard Road, Armonk, New York 10504,
United States of America

(56) Documents Cited:
US 7187256 B US 6621692 B
US 5913034 B US 20060125358 A
US 20050052850 A

(72) Inventor(s):
Ian James McCloy

(58) Field of Search:
INT CL G06F, H05K
Other: EPODOC, WPI.

(74) Agent and/or Address for Service:
IBM United Kingdom Limited
Intellectual Property Law, Hursley Park,
WINCHESTER, Hampshire, SO21 2JN,
United Kingdom

(54) Title of the Invention: **Blade enclosure**
Abstract Title: **Blade enclosure with interfaces for computer blades and conventional computers**

(57) Disclosed is a blade enclosure with a first type of physical interface for connecting a blade to the blade enclosure, and a second type of physical interface for connecting a conventional computer to the blade enclosure. The enclosure has a management component connected to the physical interfaces that manages the blades and conventional computers connected to the physical interfaces, and a body containing the physical interfaces and the management component. The enclosure may have a caddy for receiving the conventional computer. The management component may detect the connection of a conventional computer, boot the computer and connect to the processor of the computer. The management component may prevent connection to a storage device of the conventional computer and disable the wireless functionality of the conventional computer.

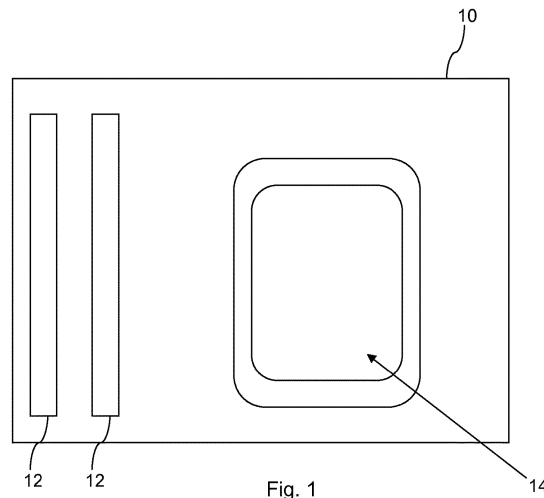

Fig. 1

1/4

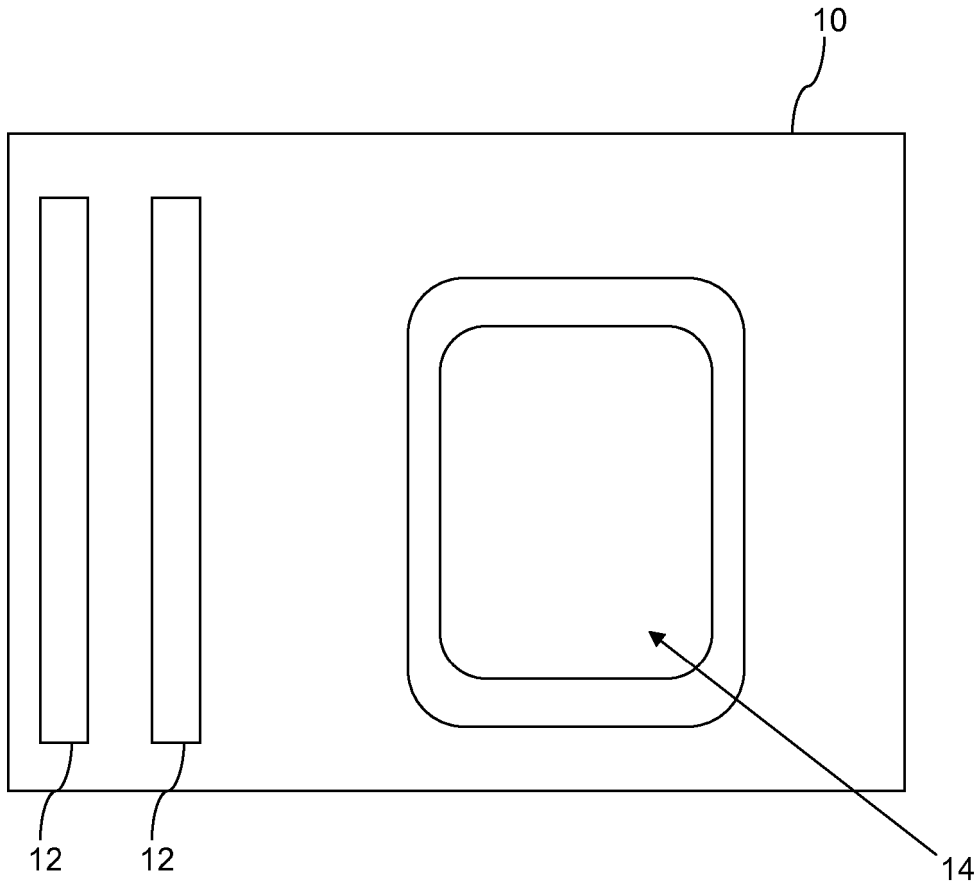

Fig. 1

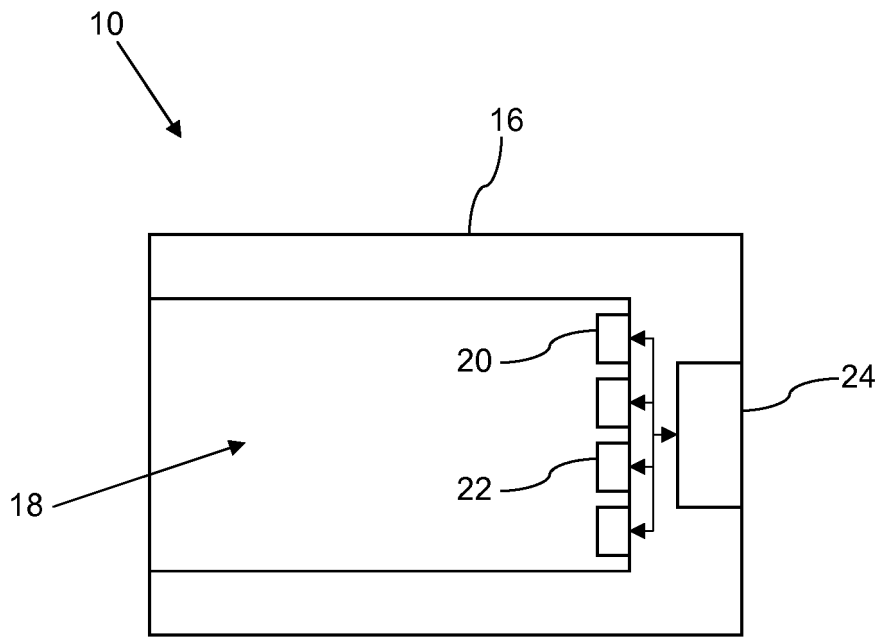

Fig. 2

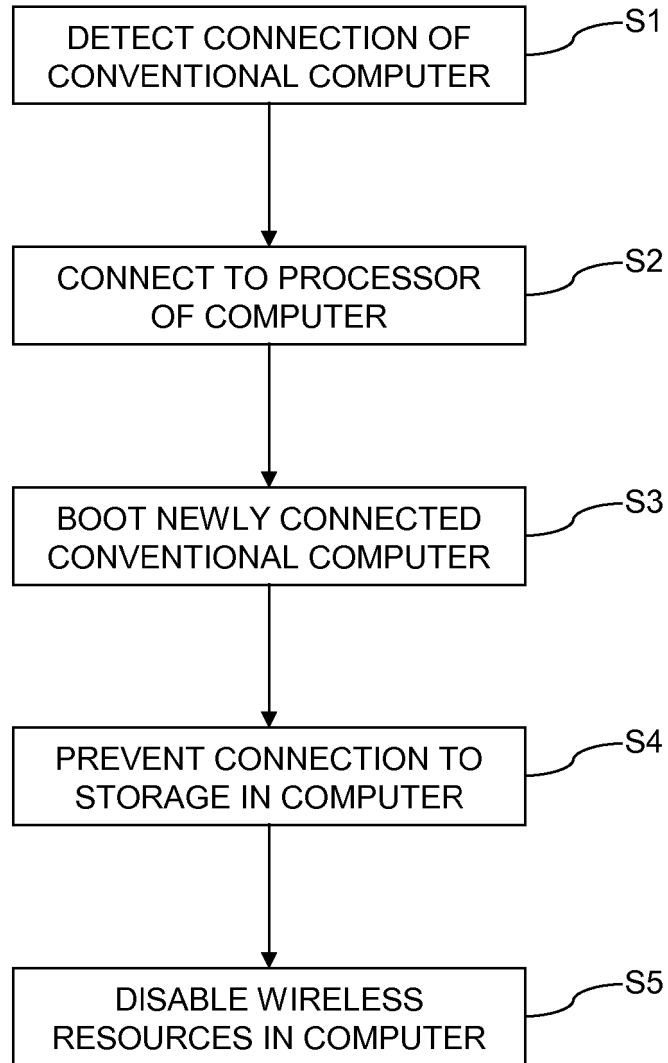

Fig. 3

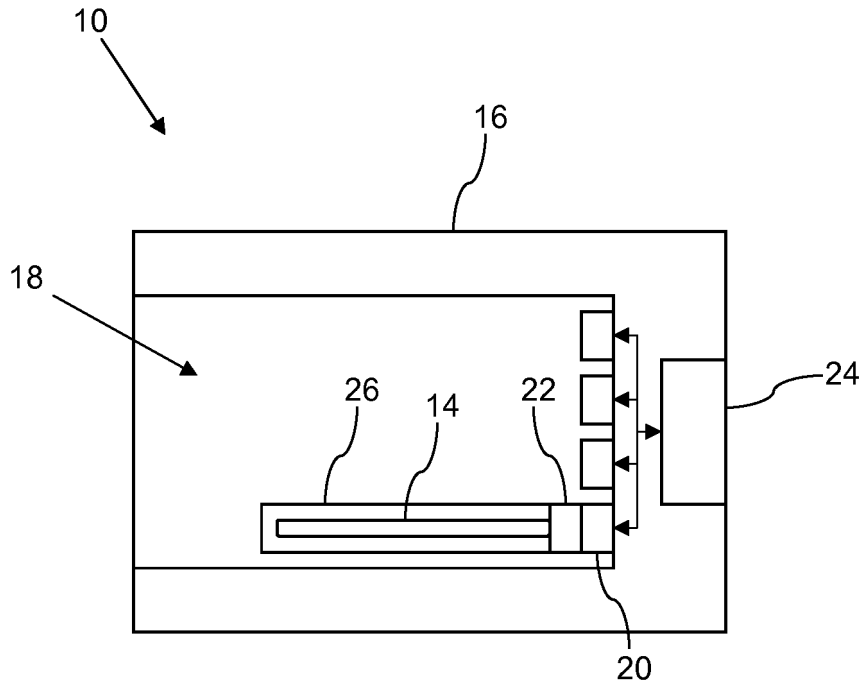

Fig. 4

BLADE ENCLOSURE

DESCRIPTION

5 FIELD OF THE INVENTION

This invention relates to a blade enclosure and to a method of operating a blade enclosure.

BACKGROUND

10

A blade enclosure is used to provide computing resources to one or more external devices. A typical blade enclosure will hold multiple blades. The individual blades within the enclosure provide computing and/or storage functionality and the blade enclosure provides services such as power, cooling, networking, various interconnects and management to the blades.

15

Together, the blades and the blade enclosure form a blade system. The blade enclosure (or chassis) performs many of the non-core computing services found in most computers, such as handling network connectivity, for example. The blades can easily be added or removed from the blade enclosure to change or upgrade the function of the blade enclosure and the overall enclosure provides a flexible solution to the delivery of computing services.

20

BRIEF SUMMARY OF THE INVENTION

25

According to a first aspect of the present invention, there is provided a blade enclosure comprising a plurality of physical interfaces of a first type, each for connecting a blade to the blade enclosure, a plurality of physical interfaces of a second type, each for connecting a conventional computer to the blade enclosure, a management component connected to the physical interfaces and for managing the blades and conventional computers connected to the physical interfaces, and a body containing the physical interfaces and the management component.

30

According to a second aspect of the present invention, there is provided a method of operating a blade enclosure comprising a plurality of physical interfaces of a first type, each for connecting a blade to the blade enclosure, a plurality of physical interfaces of a second type, each for connecting a conventional computer to the blade enclosure, a management

component connected to the physical interfaces and for managing the blades and conventional computers connected to the physical interfaces, and a body containing the physical interfaces and the management component, the method comprising the steps of detecting the connection of a conventional computer to a physical interface of a second type, and connecting to a processor of the connected conventional computer.

Owing to the invention, it is possible to provide a blade enclosure that is able to take advantage of the spare capacity available from unused computing resources. A conventional computer, in the context used here, is a portable computing device that is self-contained and provides processing, storage, power, user interface and display functionality. Such a computing device could be a laptop computer, a tablet computer, a handheld (palm) computer or a mobile (smart) phone, for example. This computing device can operate on its own, without needing to be connected to any other device, and is conventionally used by individuals to provide computing and communication needs in a professional and/or personal environment.

It is common for IT departments to keep on-hand spare tablet computers and laptop computers to either replace broken equipment or to provide to new employees. The improved blade enclosure would be able to exploit the computing power of these spare machines until they are required. Tablets and more increasingly laptops are using solid state storage and no longer have moving parts, thus can be used without wearing them out. Such spare machines are roughly the same size as a conventional blade and have extensive computational potential. Instead of storing them switched off in a cupboard until they are needed, they could be placed into a blade enclosure and be utilised.

Preferably, the blade enclosure further comprises one or more caddies for receiving a conventional computer, each caddy being connected to a physical interface of the first type and comprising a physical interface of the second type. The blade enclosure can include one or more caddies that can each be used to mount a conventional computer that is connected into the blade enclosure. Each caddy provides a cradle that connects to the tablet or laptop being added to the blade enclosure and will also connect directly to an existing interface within the blade enclosure. This provides a way of connecting in the unused computing resources without having to make any modifications to the existing interfaces within the blade enclosure.

By using the I/O connector which already exists on most tablets and laptops, which is provided for a docking station, a blade enclosure would ideally communicate with the new device when it is plugged in disable any wireless interfaces and make its CPU and memory available, for example as part of a computer cluster. The cluster nodes would be managed from the blade centre management component. Firmware on the device would run in a cluster node mode when in the blade enclosure and as an independent standard device when removed from the blade enclosure. Ideally centralised SAN storage either in the blade enclosure or connected to the blade enclosure would provide the storage to each device that is plugged in. This way the data and storage on the device is never modified and there is no risk of cross-contamination. Additionally, employees could even place their tablet or laptop into the blade enclosure when they go home at night or over a weekend, collecting their computer only when they need it.

Preferably, the management component is arranged to detect connection of a conventional computer to a physical interface of a second type, to connect to a processor of the connected conventional computer, to boot the connected conventional computer following detection of the connection, to prevent connection to a storage device of the connected conventional computer and to disable the wireless functionality of the connected conventional computer. The management component of the blade enclosure can be arranged to handle the connection of the conventional computer to the blade enclosure. When a new device is connected to the blade enclosure, the management component can perform a series of steps to boot up the new computer, prevent access to the storage of the new computer and disable any and all wireless functions of the newly connected computer. This provides a regulated process that will ensure that the new conventional computer that has been added to the blade enclosure is available for use within the blade enclosure without any risk of contamination of the storage devices within the new conventional computer and without any risk that the wireless functionality of the computer can be abused.

BRIEF DESCRIPTION OF THE DRAWINGS

Preferred embodiments of the present invention will now be described, by way of example only, with reference to the following drawings, in which:-

Figure 1 is a schematic diagram of a blade enclosure,

Figure 2 is a top plan view of the blade enclosure,
Figure 3 is a flowchart of a method of operating the blade enclosure, and
Figure 4 is a schematic diagram of a second embodiment of the blade enclosure.

5 DETAILED DESCRIPTION OF THE DRAWINGS

Figure 1 shows a blade enclosure 10 which is able to receive blades 12 and conventional computers 14. Here, the conventional computer 14 is a tablet computer. The conventional computer 14 is a portable computing device that would not normally be used with the blade enclosure 10. The conventional computer 14 has its own processing, storage, power, user interface and display functionality. Such a computing device could be a laptop computer, a tablet computer, a handheld (palm) computer or a mobile (smart) phone, for example. The modified blade enclosure 10 is configured so that it can receive conventional computers 14 in addition to the normal blades 12 that are received.

15 The blade enclosure 10 is modified by the provision of physical interfaces that can connect directly to the conventional computers 14. These interfaces may be in addition to the normal interfaces provided for connection to the blades 12 or may connect in-between a conventional computer 14 and the existing interface that would be used for a blade 12. The blade enclosure 10 can be used perfectly normally without any conventional computers 14 being present in the blade enclosure 10. In this case, the blades 12 can be added and removed from the blade enclosure 10 in a purely conventional manner. The blades 12 can be used in any slot within the blade enclosure 10.

25 The configuration of the blade enclosure 10 allows redundant conventional computers 14 to be utilised. These conventional computers 14 may be in storage, for example with the intention of provision to new employees or as potential replacements if any existing machines in use should malfunction. The modification to the blade enclosure 10 will allow these redundant conventional computers 14 to be used by being connected to the blade enclosure 10 instead of conventional blades 12. The processing and/or storage capabilities of the conventional computers 14 can be harnessed within the blade enclosure 10. Since many modern computers do not have moving parts that can wear out, this is a sensible deployment of these processing resources.

More detail of the blade enclosure 10 is shown in Figure 2. The blade enclosure 10 comprises a body 16 that defines a cavity 18. The cavity 18 is to receive the blades 12 and the conventional computers 14. The blade enclosure 10 is provided with a plurality of physical interfaces 20 of a first type, each for connecting a blade 12 to the blade enclosure 10 and a plurality of physical interfaces 22 of a second type, each for connecting a conventional computer 14 to the blade enclosure 10. These physical interfaces 20 and 22 are provided to receive the blades 12 and conventional computers 14 when they are connected into the blade enclosure 10 by an administrator.

The blade enclosure 10 further comprises a management component 24 connected to the physical interfaces 20 and 24 and for managing the blades 12 and conventional computers 14 connected to the respective physical interfaces 20 and 24. The body 16 contains the physical interfaces 20 and 22 and the management component 24. The management component 24 communicates with the blades 12 and conventional computers 14 that are connected into the blade enclosure 10 and provides a number of different functions with respect to the components that are connected into the blade enclosure 10. The management component 24 provides services such as power, cooling, networking and management to the blades 10 and conventional computers 14.

The blade enclosure 10 of Figure 2 is shown as having only four physical interfaces 20 and 22, for ease of understanding, but in reality an enclosure such as that shown in Figures 1 and 2 will have twelve or more slots available to receive blades and conventional computers 14. Although Figure 2 shows the provision of the physical interfaces 20 and 22 in a single line, they may be so arranged that each slot within the blade enclosure 10 contains both types of physical interface 20 and 22, which will allow every slot in the blade enclosure 10 to receive either a blade 10 or a conventional computer 14.

A method of operating the blade enclosure 10 is shown in Figure 3. The management component 24 of the blade enclosure 10 is arranged to detect connection of a conventional computer 14 to a physical interface 22 of the blade enclosure 10 (step S1), to connect to a processor of the connected conventional computer 14 (step S2), to boot the connected conventional computer 14 following detection of the connection (step S3), to prevent connection to a storage device of the connected conventional computer 14 (step S4) and to disable the wireless functionality of the connected conventional computer (step S5). In this

way, the management component 24 is able to configure a connection to the newly connected conventional computer 14.

5 Only the first two steps of this method are essential in order to configure a connection to the conventional computer 14 that has been connected to the blade enclosure 10. Step S3, which comprises booting the newly connected conventional computer 14 from the management component 24 of the blade enclosure, could be replaced by some other booting method. For example, the administrator that is intending to connect a conventional computer 14 to the blade enclosure could turn on and boot the conventional computer 14 prior to the insertion of
10 the conventional computer 14 into the blade enclosure 10. Alternatively, the conventional computer 14 could have software running thereon that is able to detect the connection and boot the conventional computer 14 automatically.

15 Steps S4 and S5, which comprise respectively preventing any direct connection to the storage device of the conventional computer 14 that has been connected and disabling the wireless functionality of the conventional computer 14 are also not essential, but are preferable process steps that help to ensure the integrity of the added conventional computer 14, on the understanding that this device will be removed at some future point and used for a different purpose. It is advantageous to prevent any contamination of the storage device(s) present on
20 the conventional computer 14 that has been connected into the blade enclosure 10. Similarly the wireless functions should be disabled in order to prevent any unauthorised access and to prevent any accidental wireless transmissions from the conventional computer 14.

25 A second embodiment of the blade enclosure 10 is shown in Figure 4. This blade enclosure 10 further comprises a caddy 26 for receiving a conventional computer 14, shown here as a tablet computer 14. The caddy 26 is connected to a physical interface 20 of the first type and comprises a physical interface 22 of the second type. This physical interface 22 mates with a suitable interface on the conventional computer 14. In this way, the caddy 26 provides a simple way of connecting a conventional computer 14 into the blade enclosure 10. The caddy
30 26 can itself be removed from the blade enclosure 10 in order to get direct access to the interface 20.

The blade enclosure 10 can include multiple caddies 26 that can each be used to mount a conventional computer 14 that is connected into the blade enclosure 10. Each caddy 26

provides an external shell that receives the conventional computer 14 being added to the blade enclosure 10 and will connect directly to an existing interface 20 within the blade enclosure 10. This provides a way for an administrator to connect in any unused computing resources, such as the tablet 14, without their having to be any modifications to the existing interfaces 20 found within the blade enclosure 10. The interface 22 within the caddy 26 can be specific to the hardware 14 being added or can be a suitably standardised interface.

By using existing I/O connections on tablets and laptops 14, such as those provided for a docking station, the blade enclosure 10 would ideally communicate with the new device 14 when it is plugged in and make its CPU and memory available as part of a computer cluster. The cluster nodes, of which the device 14 would be one, would be managed from the blade centre management component 24. Firmware on the device 14 would run in a cluster node mode when in the blade enclosure 10 and as an independent standard device 14 when removed from the blade enclosure 10. By operating the additional computers 14 as cluster nodes they can be added and removed from the blade enclosure with the minimum amount of reconfiguration.

CLAIMS

1. A blade enclosure comprising:
 - 5 ○ a plurality of physical interfaces of a first type, each for connecting a blade to the blade enclosure,
 - a plurality of physical interfaces of a second type, each for connecting a conventional computer to the blade enclosure,
 - a management component connected to the physical interfaces and for managing the blades and conventional computers connected to the physical interfaces, and
 - 10 ○ a body containing the physical interfaces and the management component.

2. An enclosure according to claim 1, and further comprising a caddy for receiving a conventional computer, the caddy connected to a physical interface of the first type and comprising a physical interface of the second type.

- 15 3. An enclosure according to claim 1 or 2, wherein the management component is arranged to detect connection of a conventional computer to a physical interface of a second type and to connect to a processor of the connected conventional computer.

- 20 4. An enclosure according to claim 1, 2 or 3, wherein the management component is arranged to detect connection of a conventional computer to a physical interface of a second type and to boot the connected conventional computer following detection of the connection.

- 25 5. An enclosure according to any preceding claim, wherein the management component is arranged to detect connection of a conventional computer to a physical interface of a second type and to prevent connection to a storage device of the connected conventional computer.

- 30 6. An enclosure according to any preceding claim, wherein the management component is arranged to detect connection of a conventional computer to a physical interface of a second type and to disable the wireless functionality of the connected conventional computer.

7. A method of operating a blade enclosure comprising a plurality of physical interfaces of a first type, each for connecting a blade to the blade enclosure, a plurality of physical

interfaces of a second type, each for connecting a conventional computer to the blade enclosure, a management component connected to the physical interfaces and for managing the blades and conventional computers connected to the physical interfaces, and a body containing the physical interfaces and the management component, the method comprising the steps of:

- detecting the connection of a conventional computer to a physical interface of a second type, and
- connecting to a processor of the connected conventional computer.

8. A method according to claim 7, wherein the blade enclosure further comprises a caddy for receiving a conventional computer, the caddy connected to a physical interface of the first type and comprising a physical interface of the second type.

9. A method according to claim 7 or 8, and further comprising, following detecting connection of a conventional computer to a physical interface of a second type, booting the connected conventional computer following detection of the connection.

10. A method according to claim 7, 8 or 9, and further comprising, following detecting connection of a conventional computer to a physical interface of a second type, preventing connection to a storage device of the connected conventional computer.

11. A method according to any one of claims 7 to 10, and further comprising, following detecting connection of a conventional computer to a physical interface of a second type, disabling the wireless functionality of the connected conventional computer.

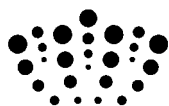

Application No: GB1209089.0

Examiner: Mr David Maskery

Claims searched: 1 - 11

Date of search: 4 September 2012

Patents Act 1977: Search Report under Section 17

Documents considered to be relevant:

Category	Relevant to claims	Identity of document and passage or figure of particular relevance
X	1 and 2 at least	US 7187256 B (SENOGLES et AL) See columns 3 and 9 - 11.
X	1 and 2 at least	US 2006/0125358 A (WILLIAMSON) See page 2.
X	1 and 2 at least	US 2005/0052850 A (DICKY et AL) See pages 2 and 3.
X	1 and 2 at least	US 6621692 B (JOHNSON et AL) See columns 5 to 8.
X	1 and 2 at least	US 5913034 B (MALCOLM) See columns 7 to 10.

Categories:

X	Document indicating lack of novelty or inventive step	A	Document indicating technological background and/or state of the art.
Y	Document indicating lack of inventive step if combined with one or more other documents of same category.	P	Document published on or after the declared priority date but before the filing date of this invention.
&	Member of the same patent family	E	Patent document published on or after, but with priority date earlier than, the filing date of this application.

Field of Search:

Search of GB, EP, WO & US patent documents classified in the following areas of the UKC^X :

Worldwide search of patent documents classified in the following areas of the IPC

G06F; H05K

The following online and other databases have been used in the preparation of this search report

EPODOC, WPI.

International Classification:

Subclass	Subgroup	Valid From
G06F	0015/16	01/01/2006
H05K	0007/14	01/01/2006