



US 20090114691A1

(19) **United States**

(12) **Patent Application Publication**
BIZZELL et al.

(10) **Pub. No.: US 2009/0114691 A1**

(43) **Pub. Date: May 7, 2009**

(54) **BABY CARE ASSEMBLY**

Related U.S. Application Data

(75) Inventors: **Daniel Lee BIZZELL**, Davidson,
NC (US); **Ian D. KOVACEVICH**,
Charlotte, NC (US); **Jerry SHEW**,
Charlotte, NC (US)

(60) Provisional application No. 60/983,921, filed on Oct.
30, 2007, provisional application No. 61/026,475,
filed on Feb. 6, 2008.

Publication Classification

Correspondence Address:
TILLMAN WRIGHT, PLLC
P.O. BOX 473909
CHARLOTTE, NC 28247 (US)

(51) **Int. Cl.**
A45F 4/00 (2006.01)
A47D 13/02 (2006.01)
A45B 11/00 (2006.01)

(52) **U.S. Cl.** **224/577; 224/158; 224/186**

(57) **ABSTRACT**

A baby care assembly includes a baby carrier positionable between an open, use configuration, wherein a baby may be placed in the carrier, and a closed, folded configuration; and a baby bag configured and dimensioned to receive and retain the baby carrier when the baby carrier is in the closed, folded configuration.

(73) Assignee: **SNUGGLE NEST, LLC**,
Charlotte, NC (US)

(21) Appl. No.: **12/262,143**

(22) Filed: **Oct. 30, 2008**

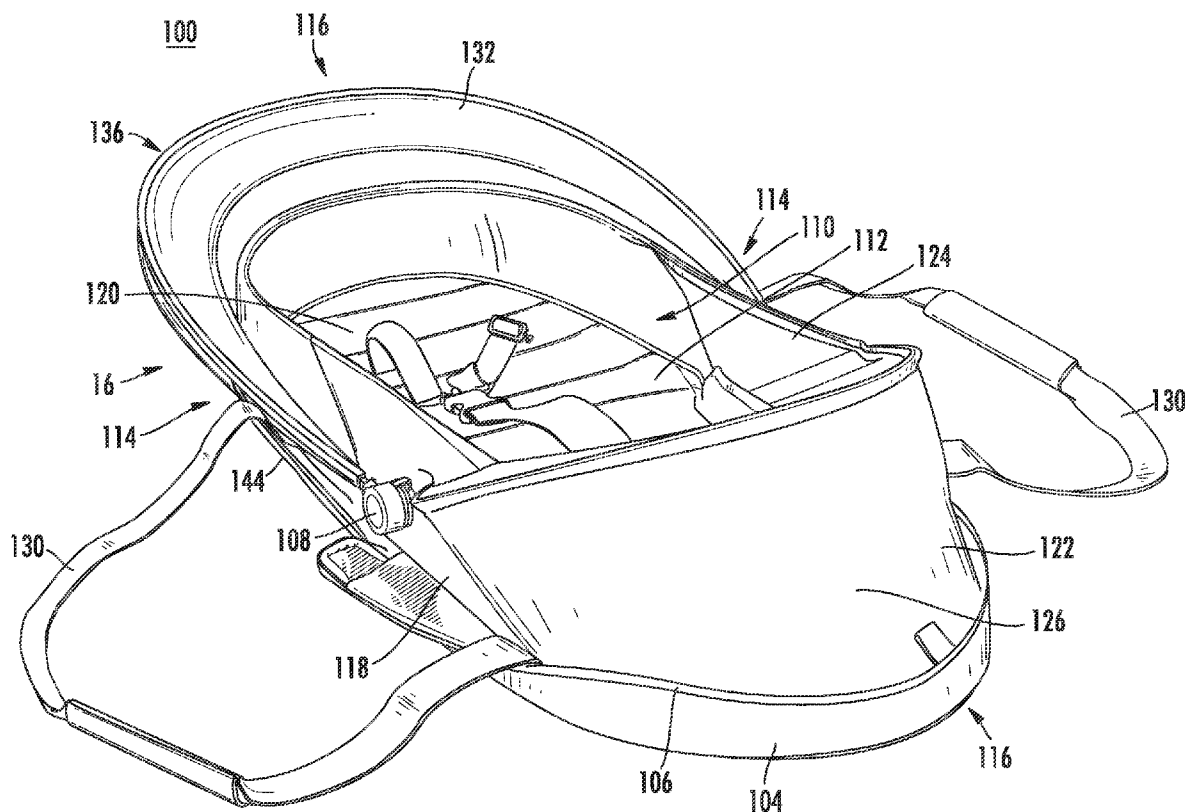

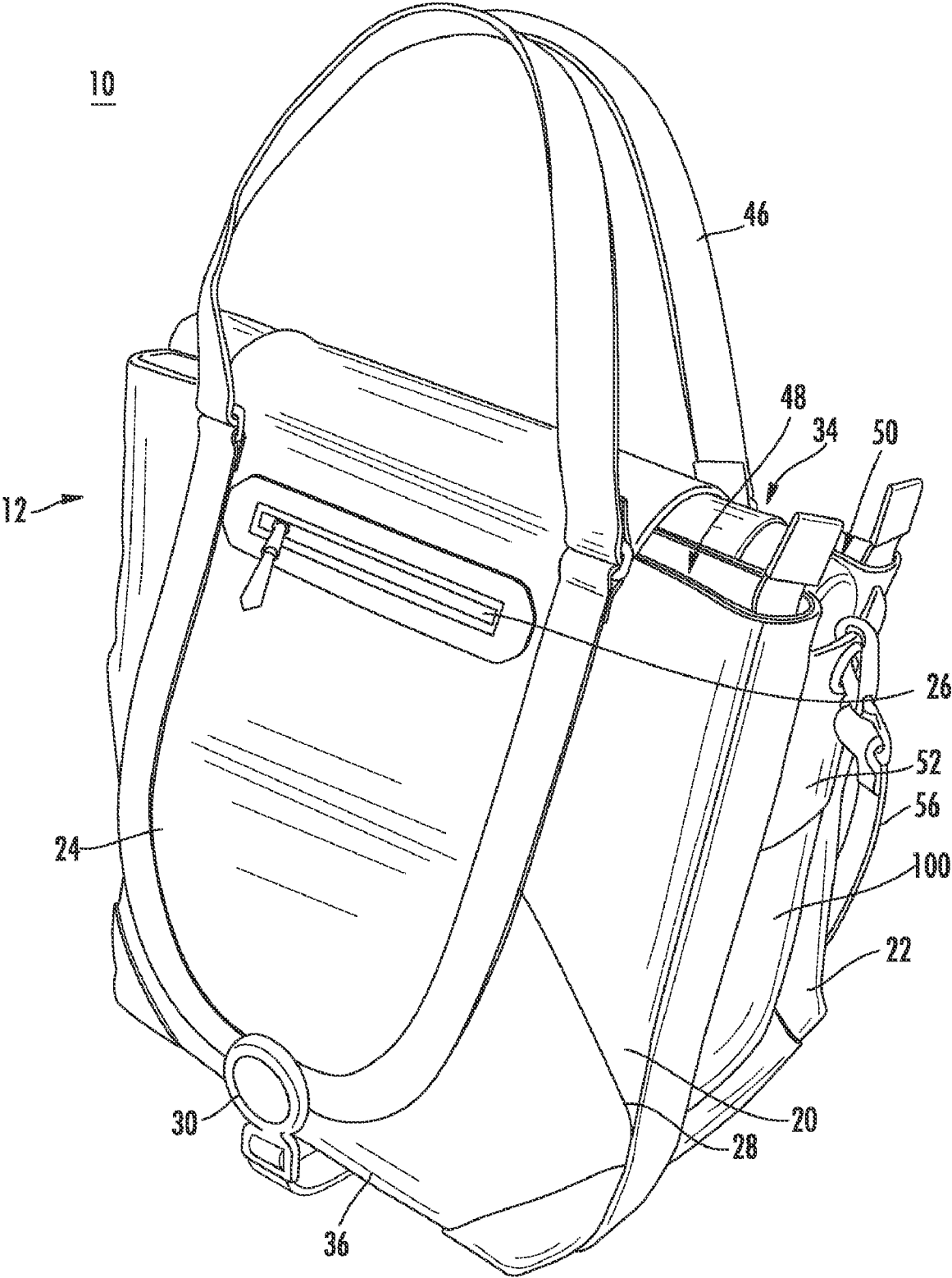

FIG. 1

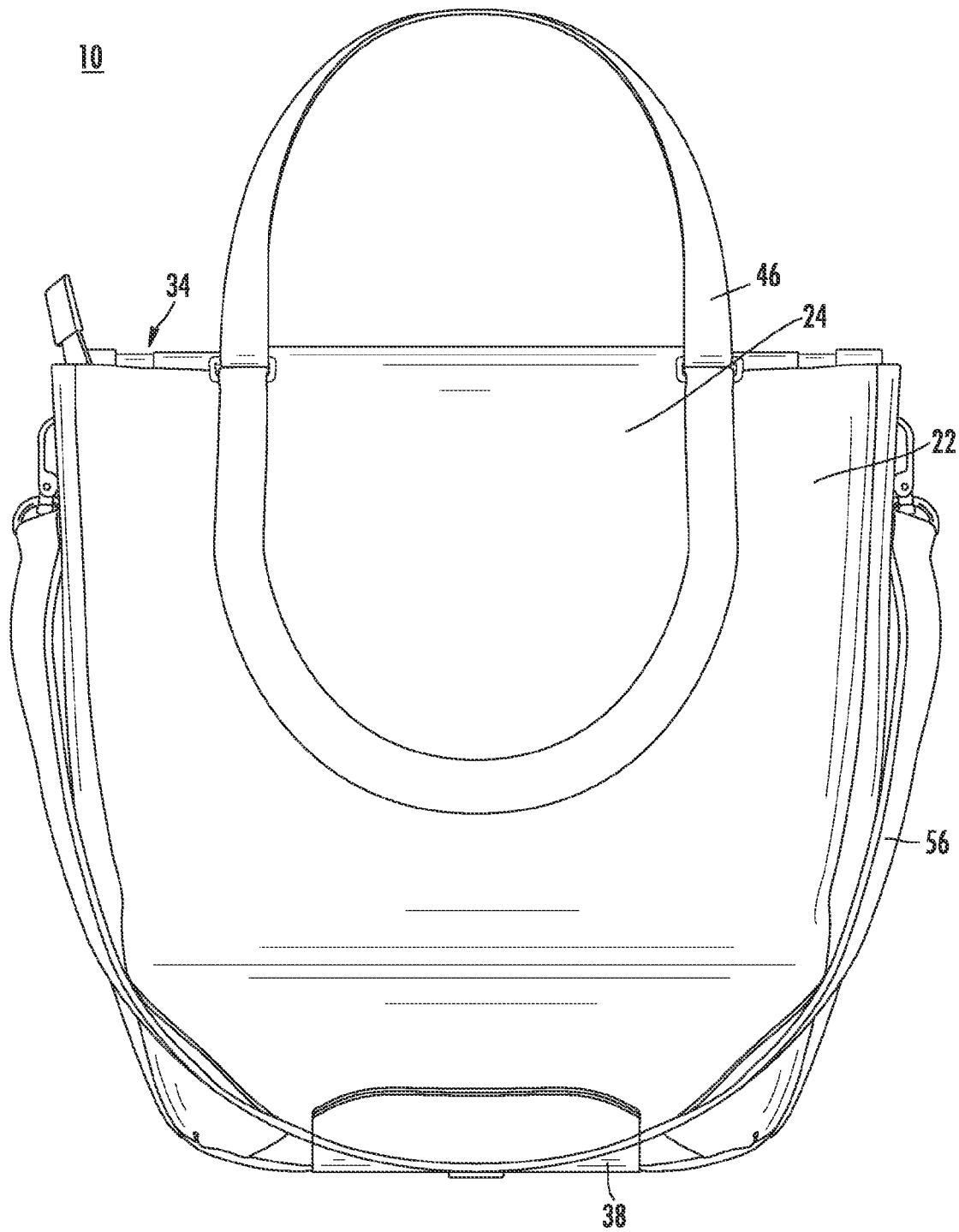

FIG. 2

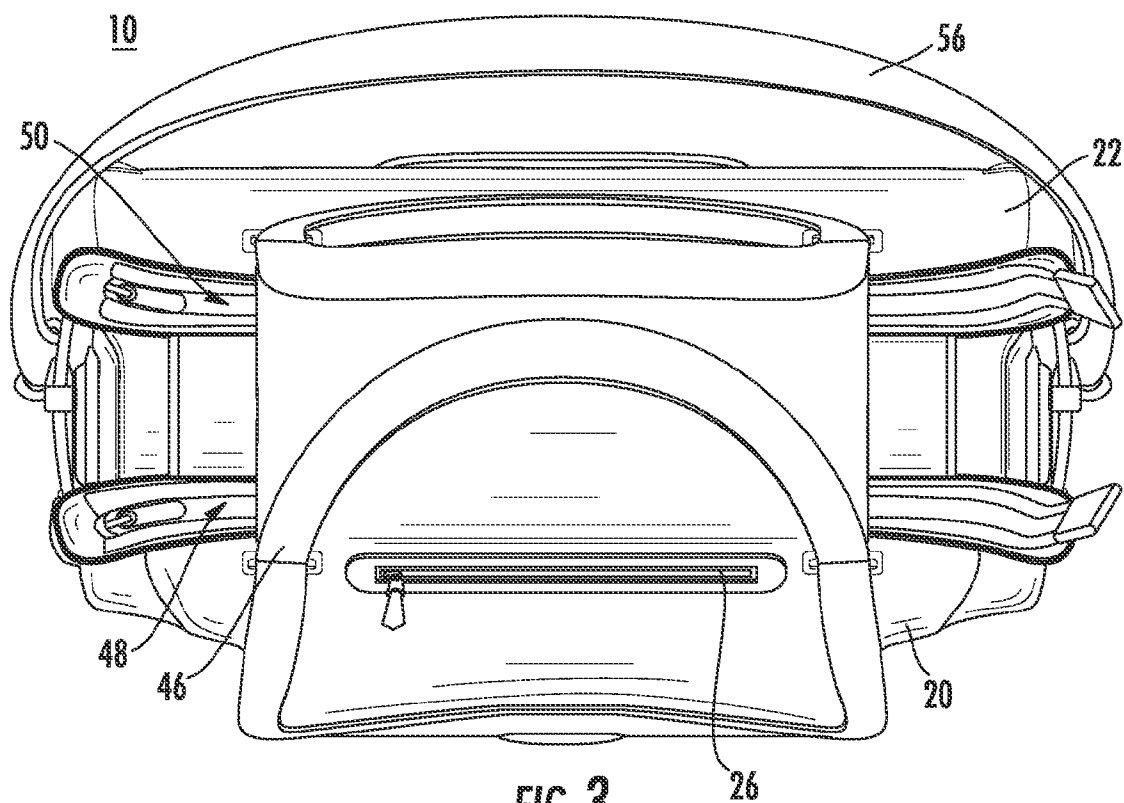

FIG. 3

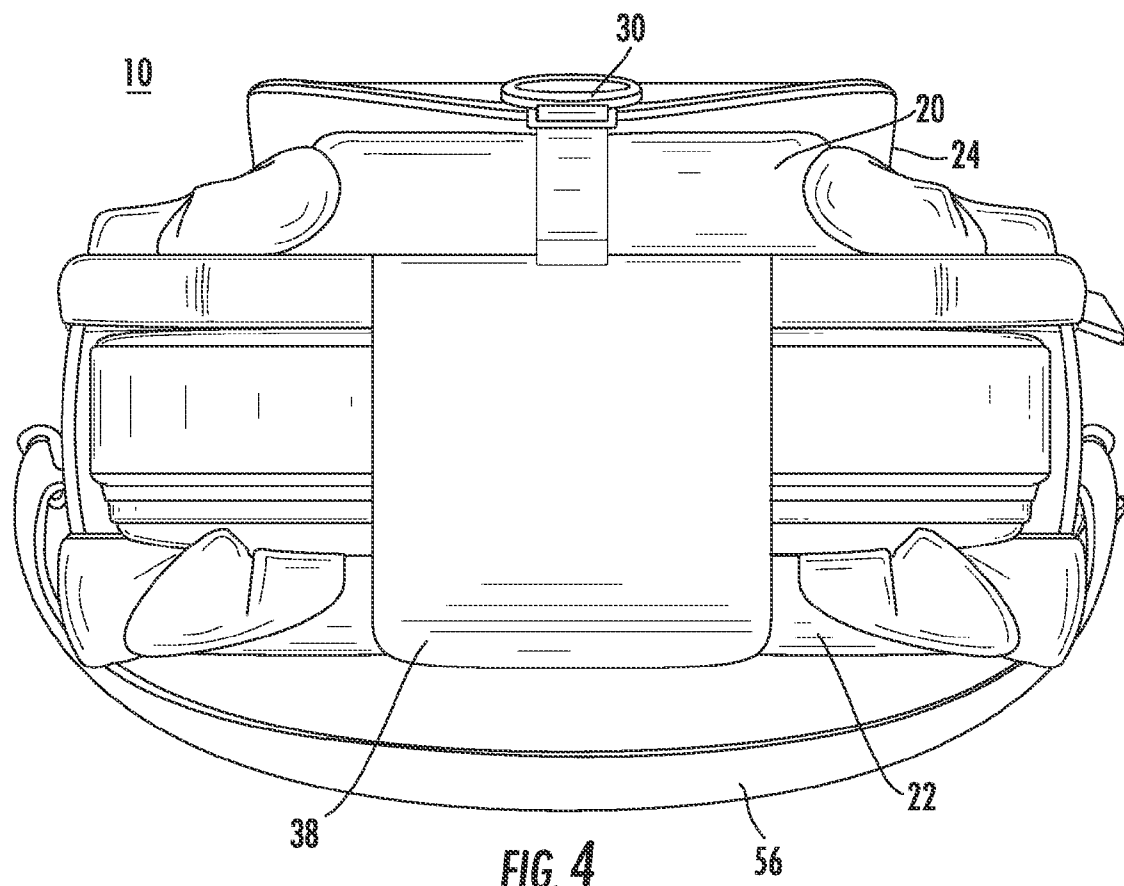

FIG. 4

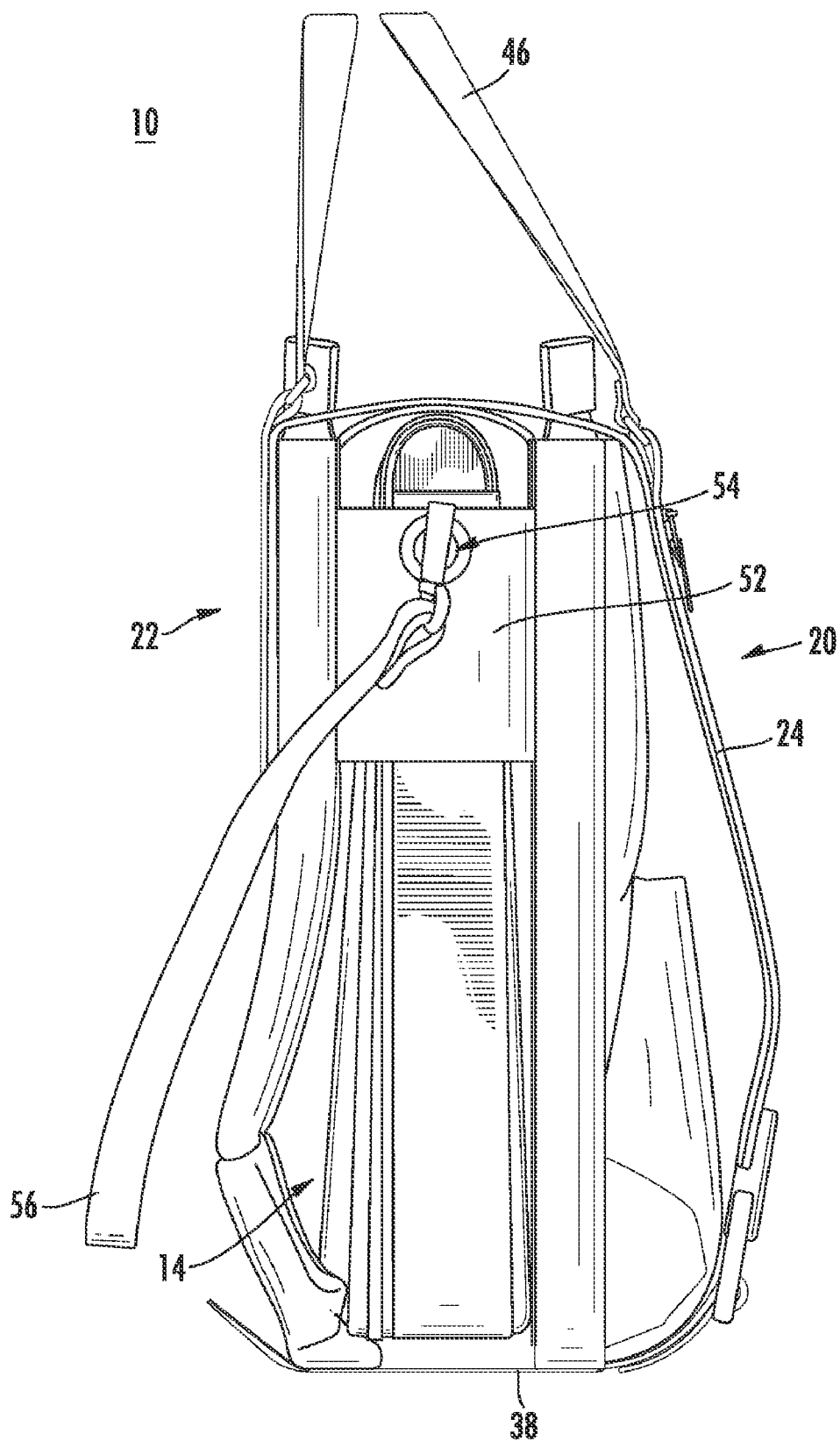
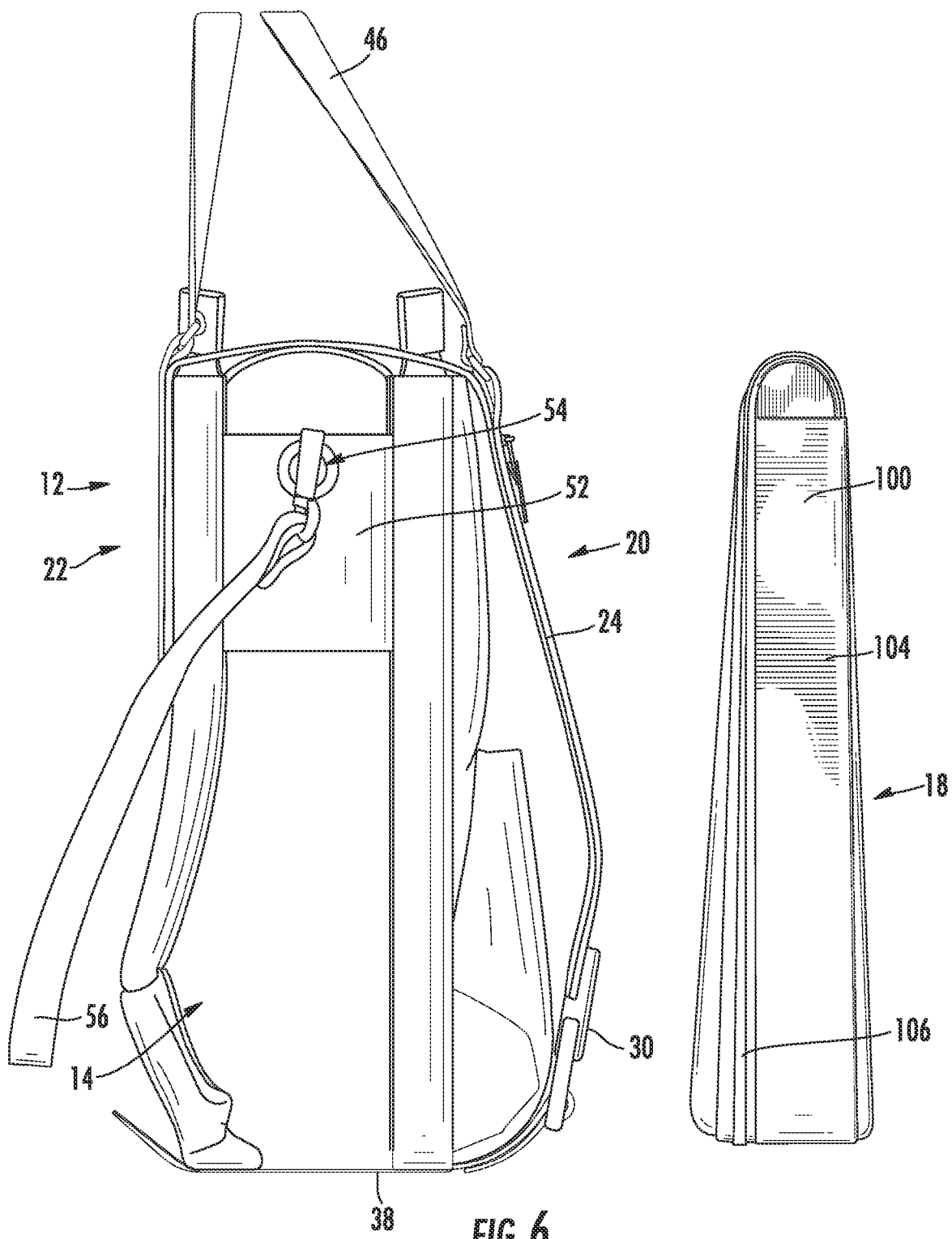

FIG. 5



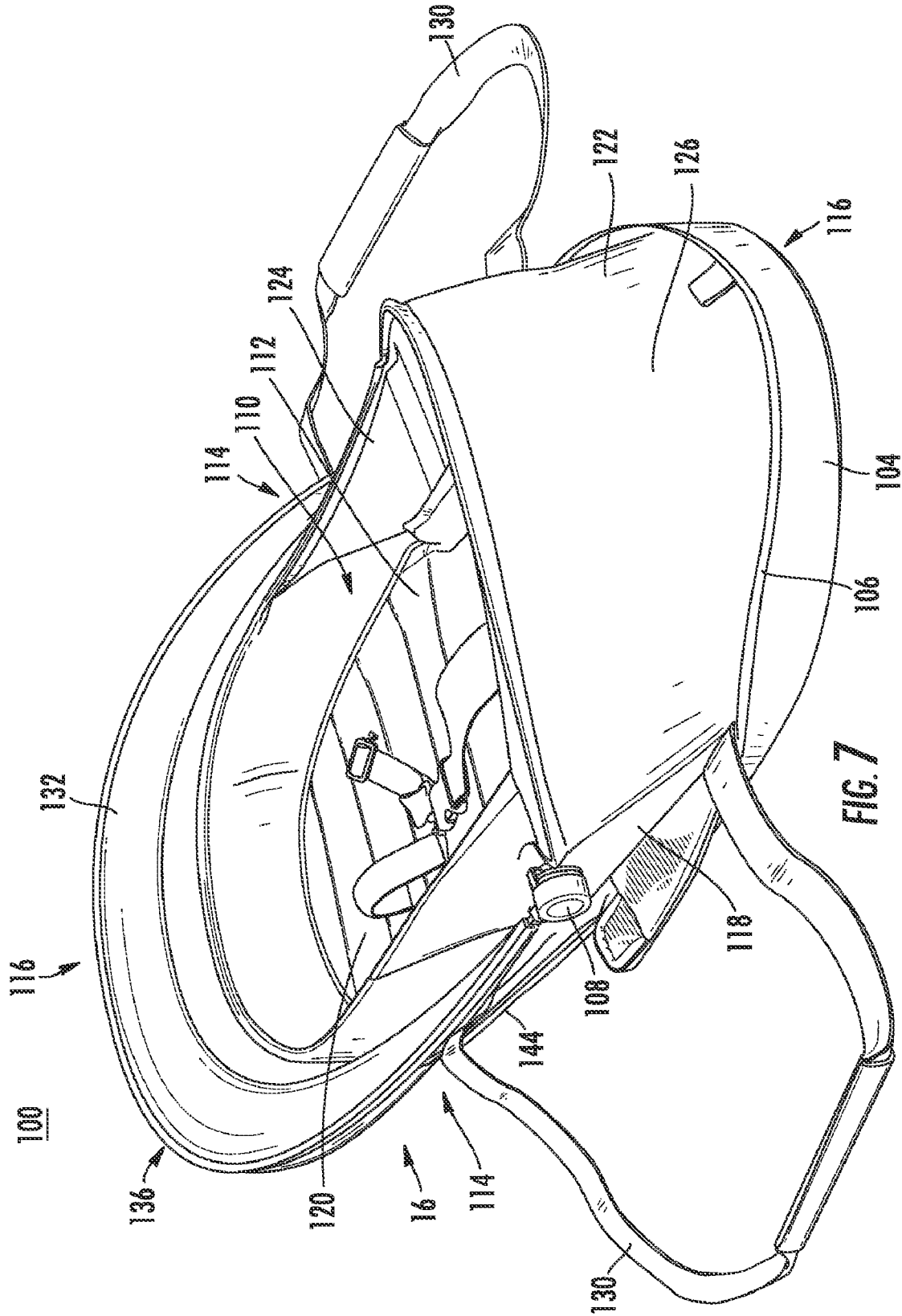

FIG. 7

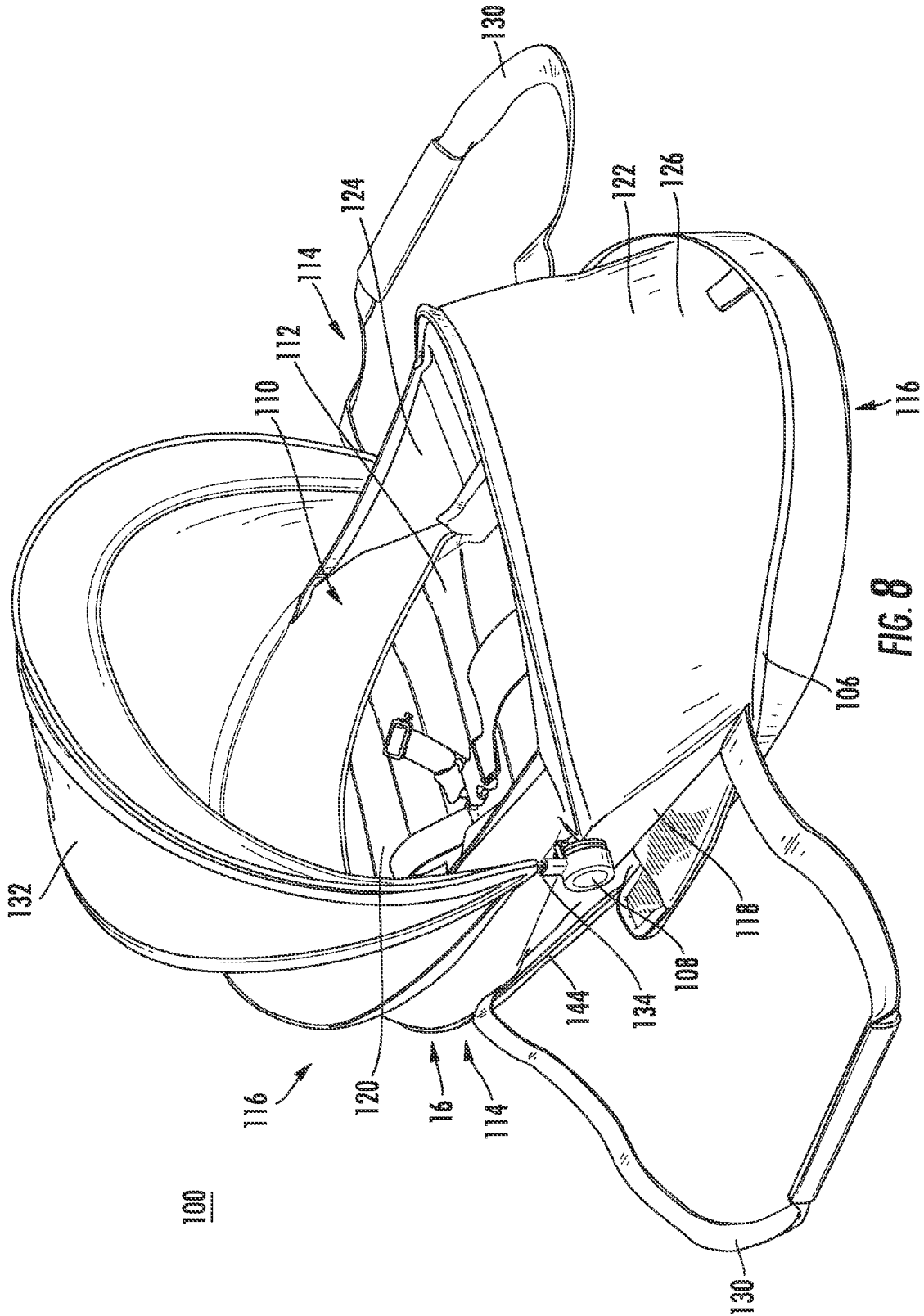

FIG. 8

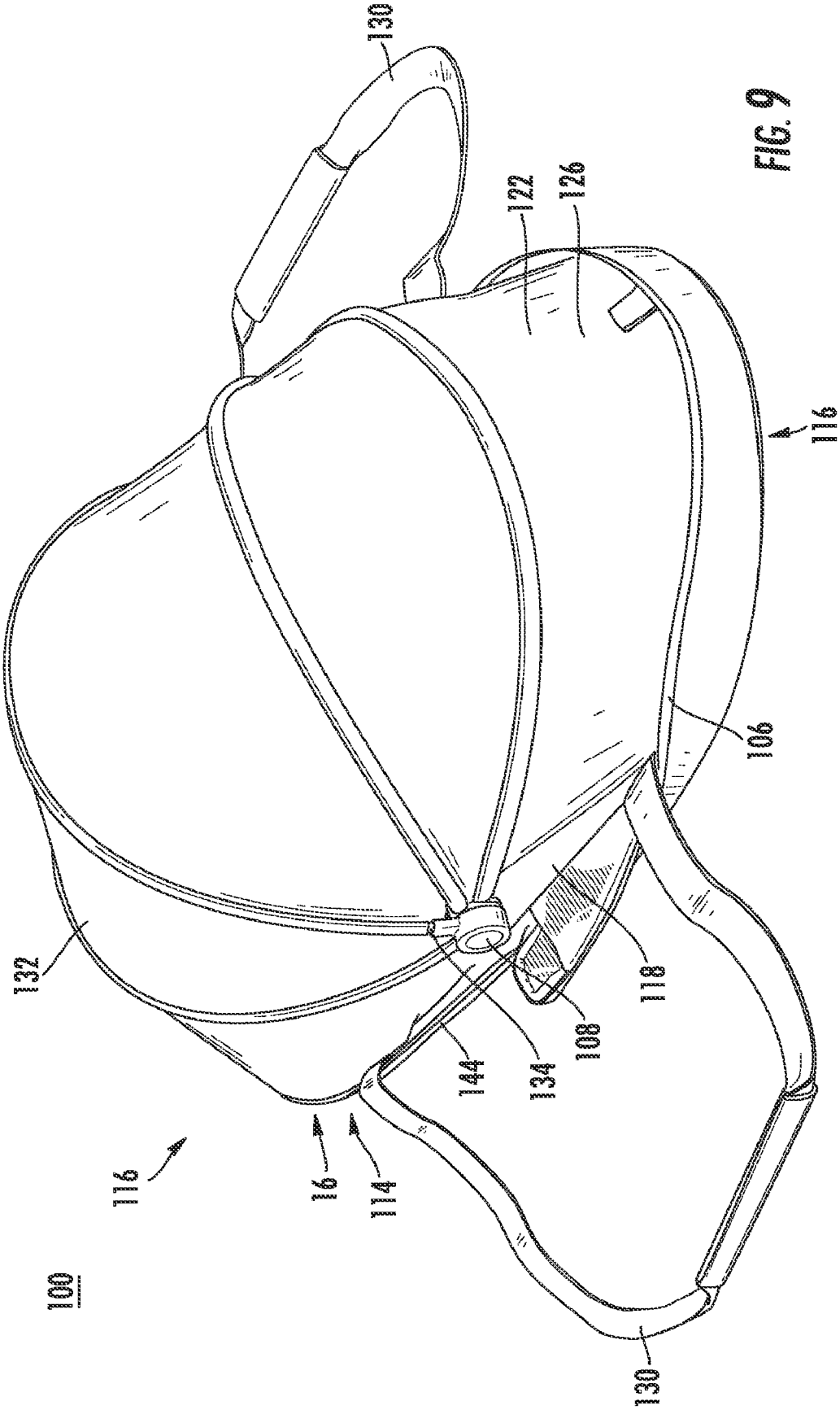

FIG. 9

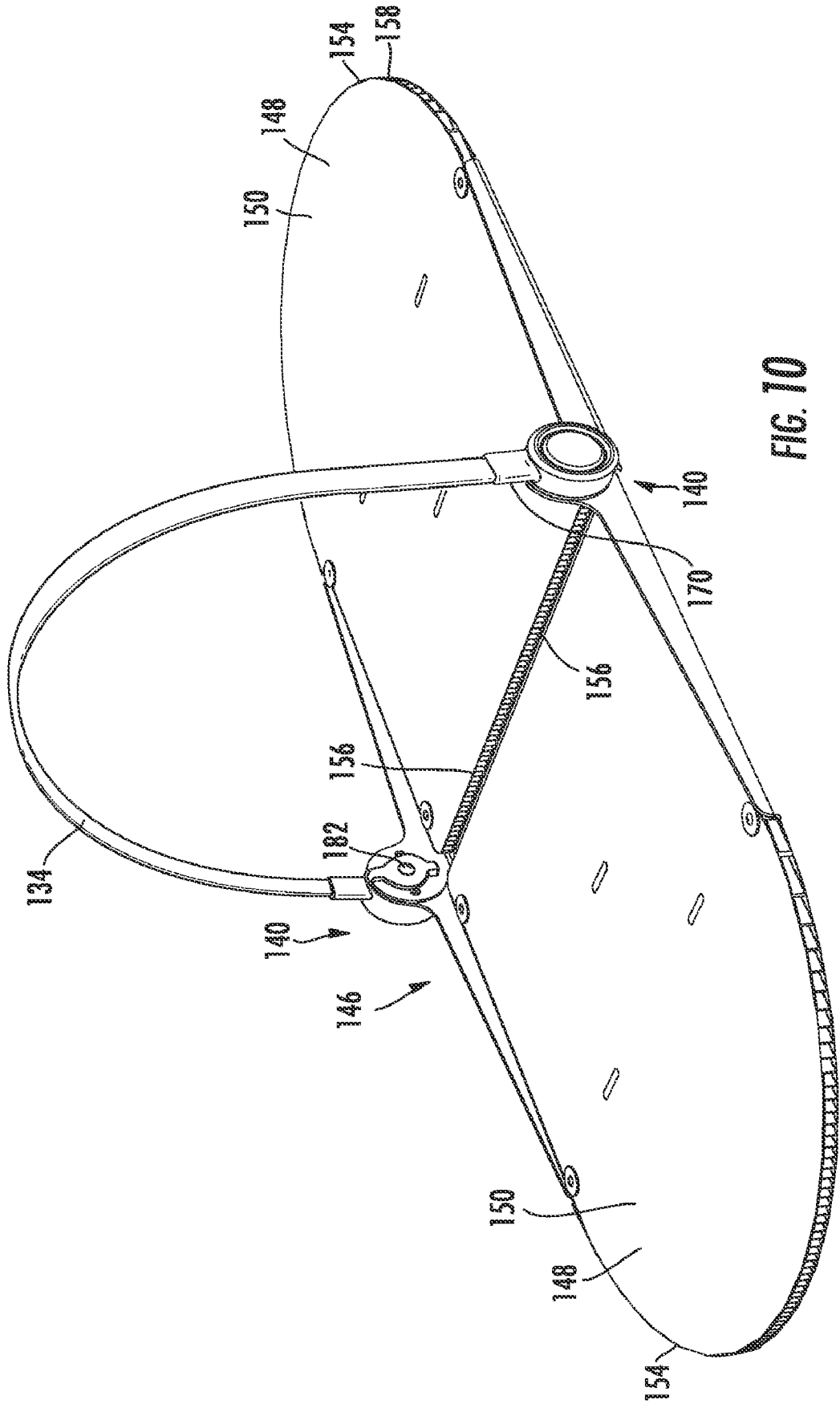

FIG. 10

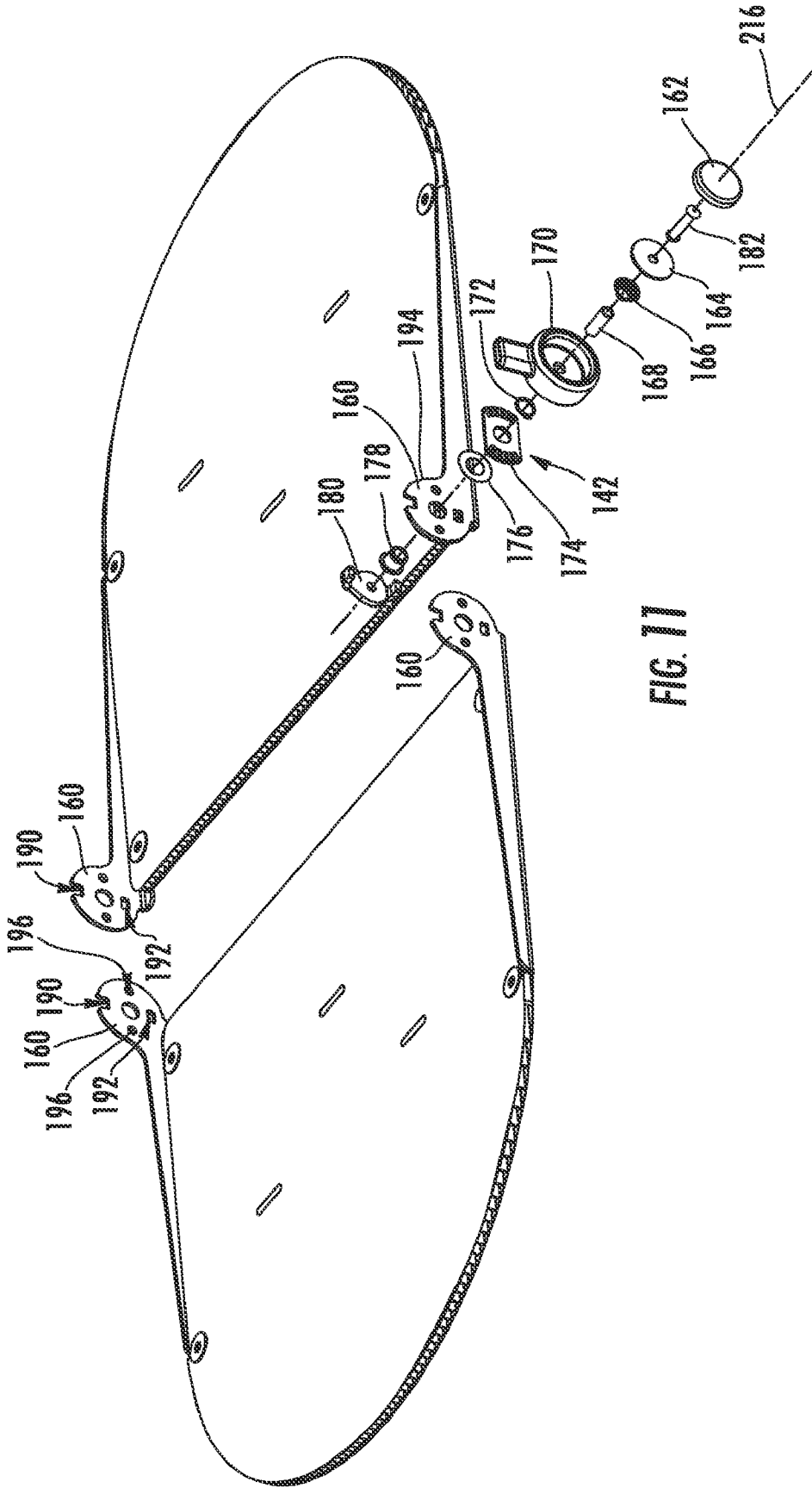

FIG. 11

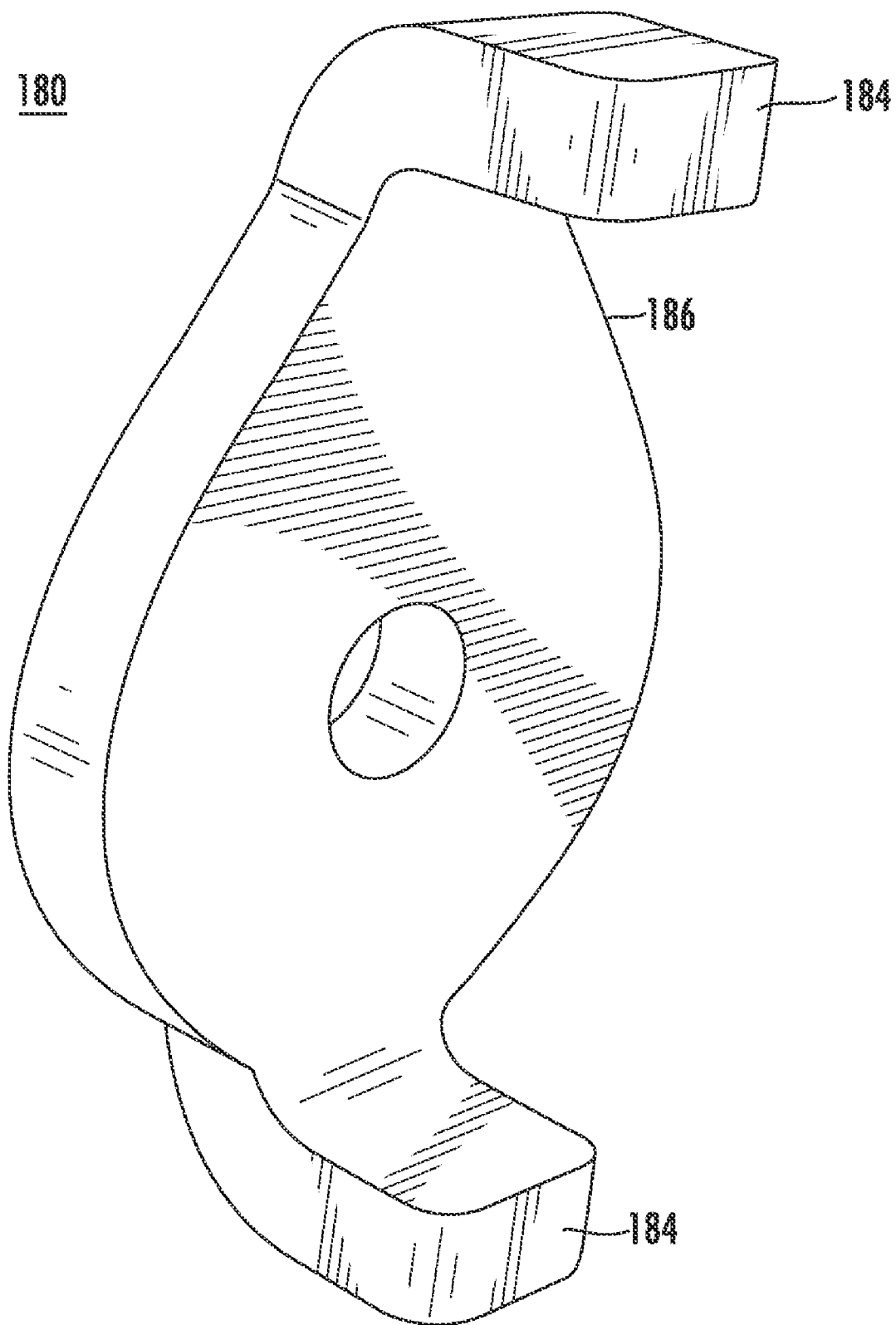

FIG. 12a

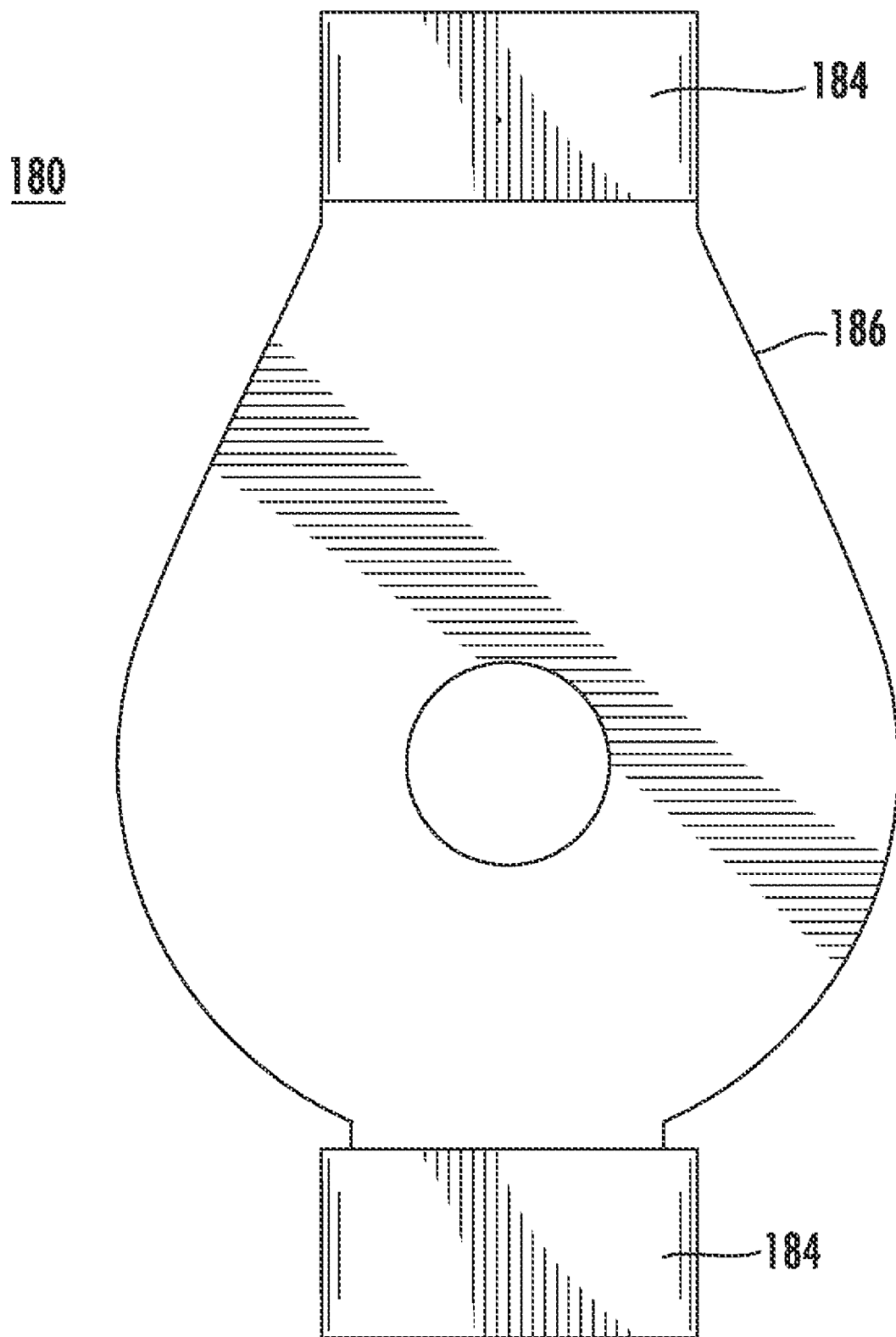

FIG. 12b

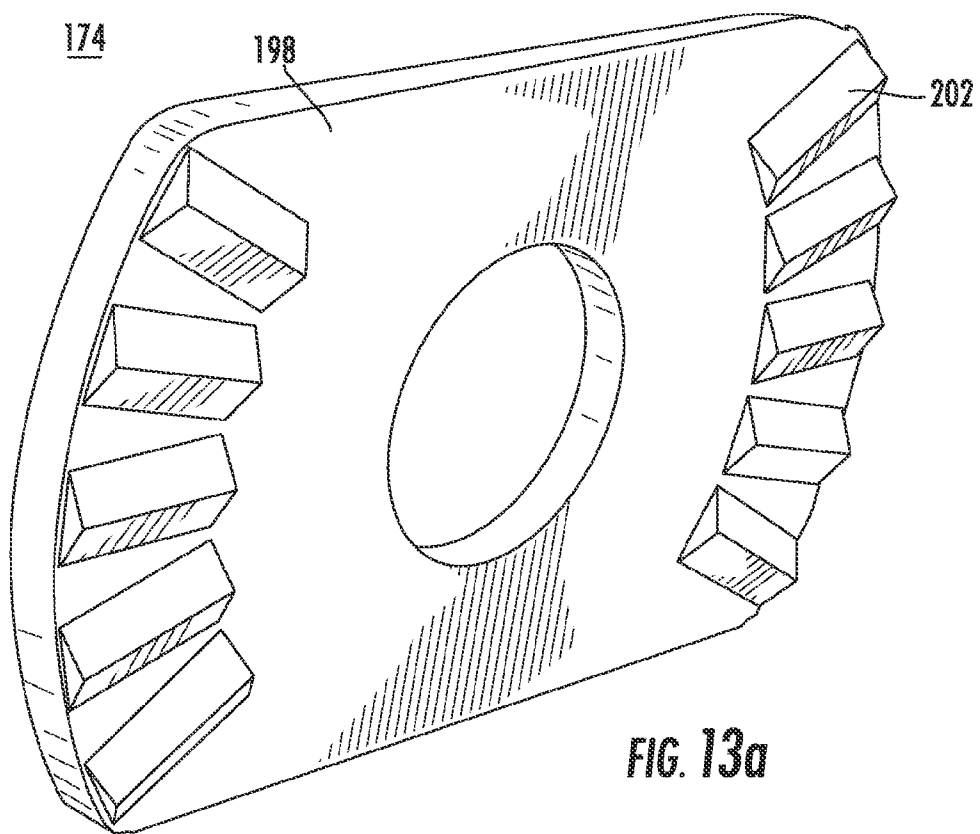

FIG. 13a

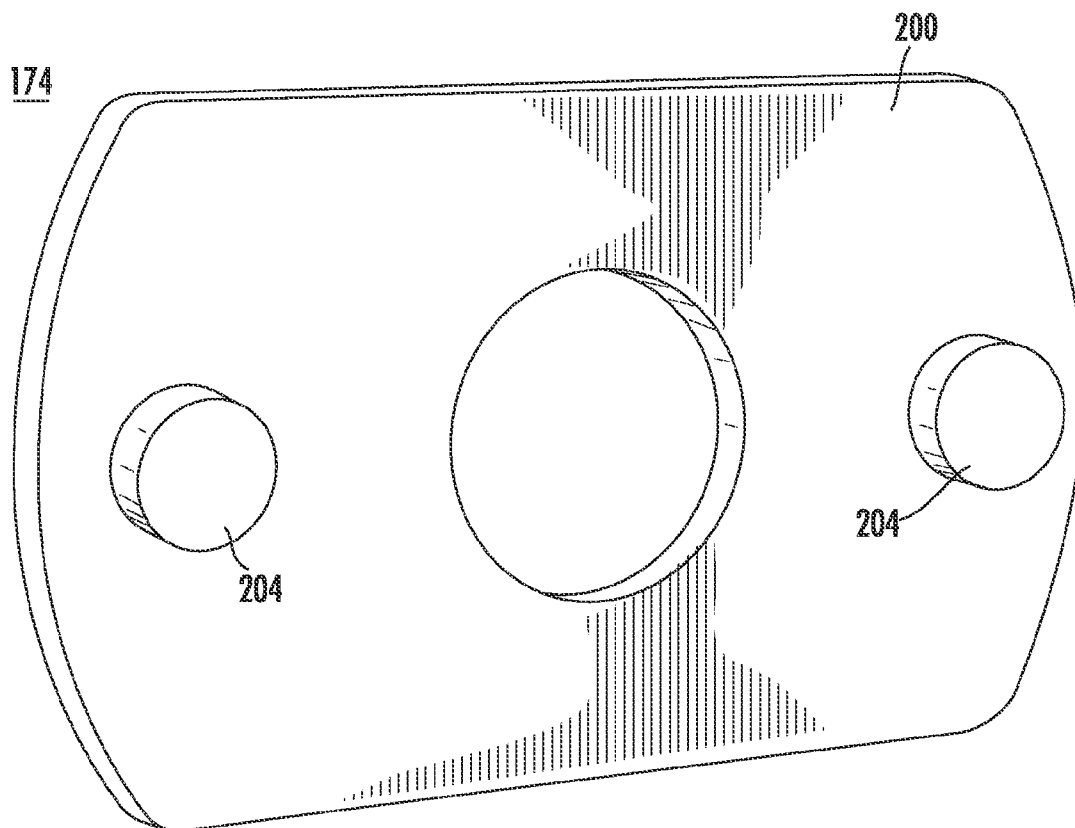

FIG. 13b

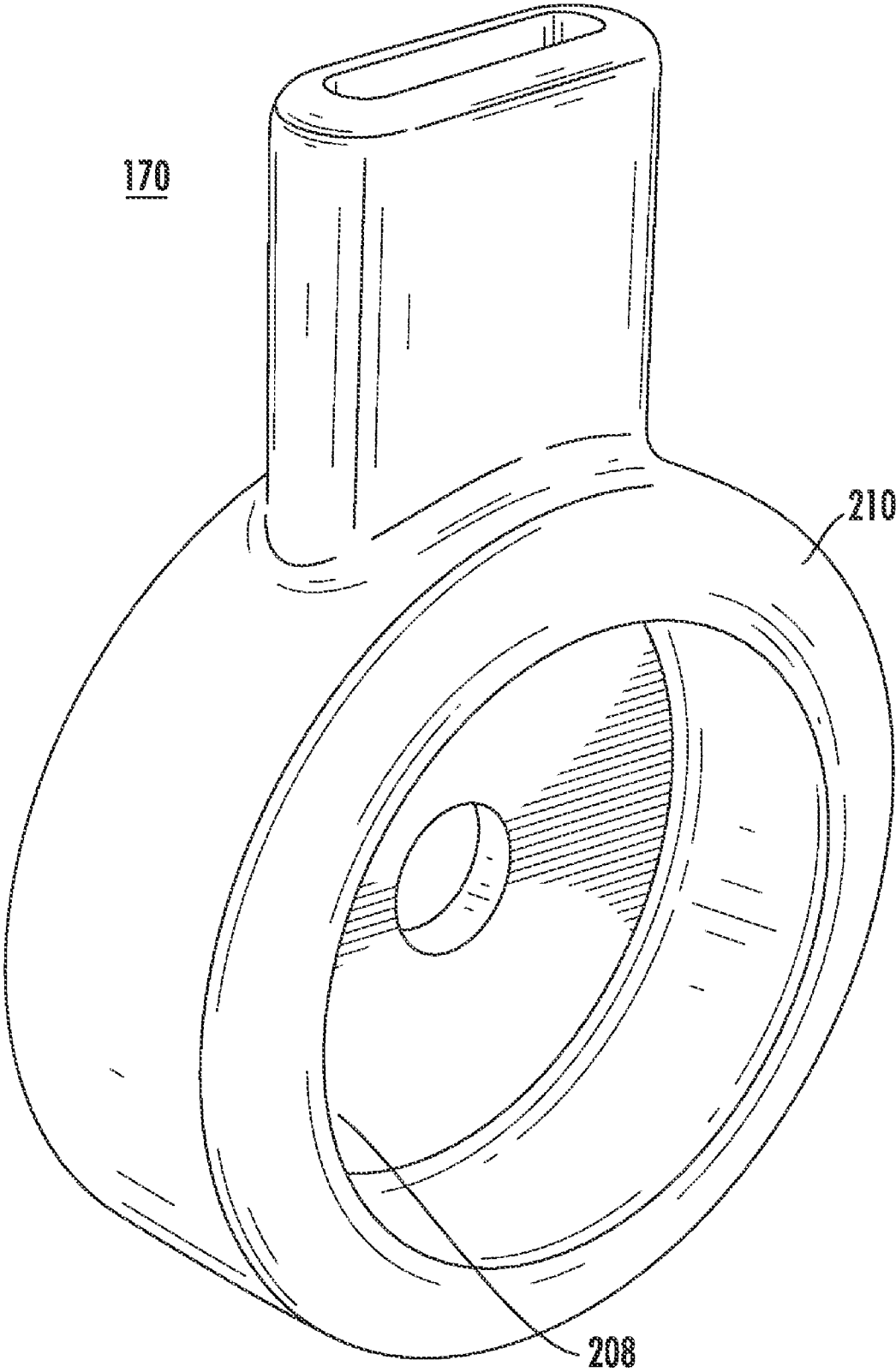

FIG. 14a

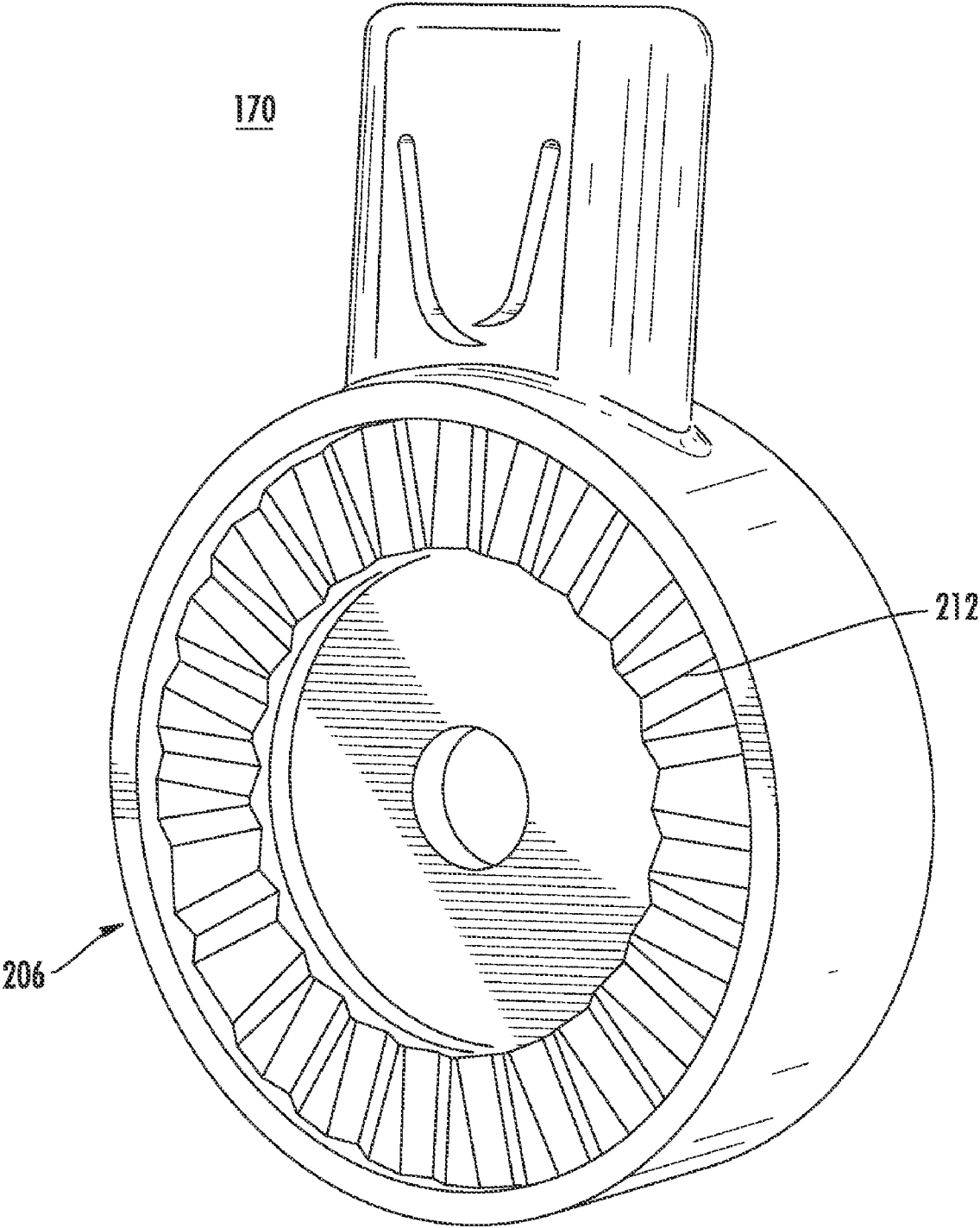

FIG. 14b

310



Fig. 15

310

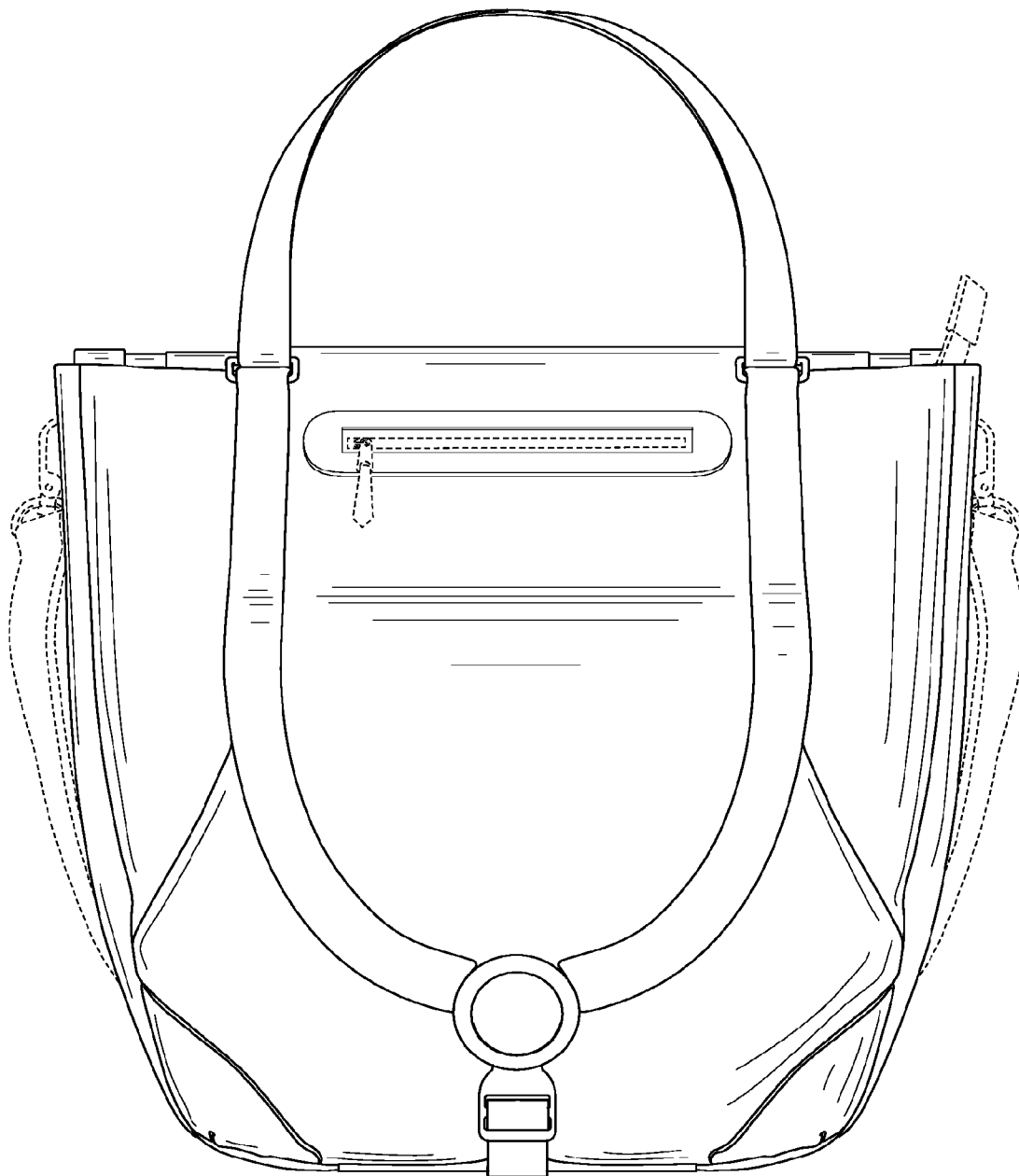

Fig. 16

310

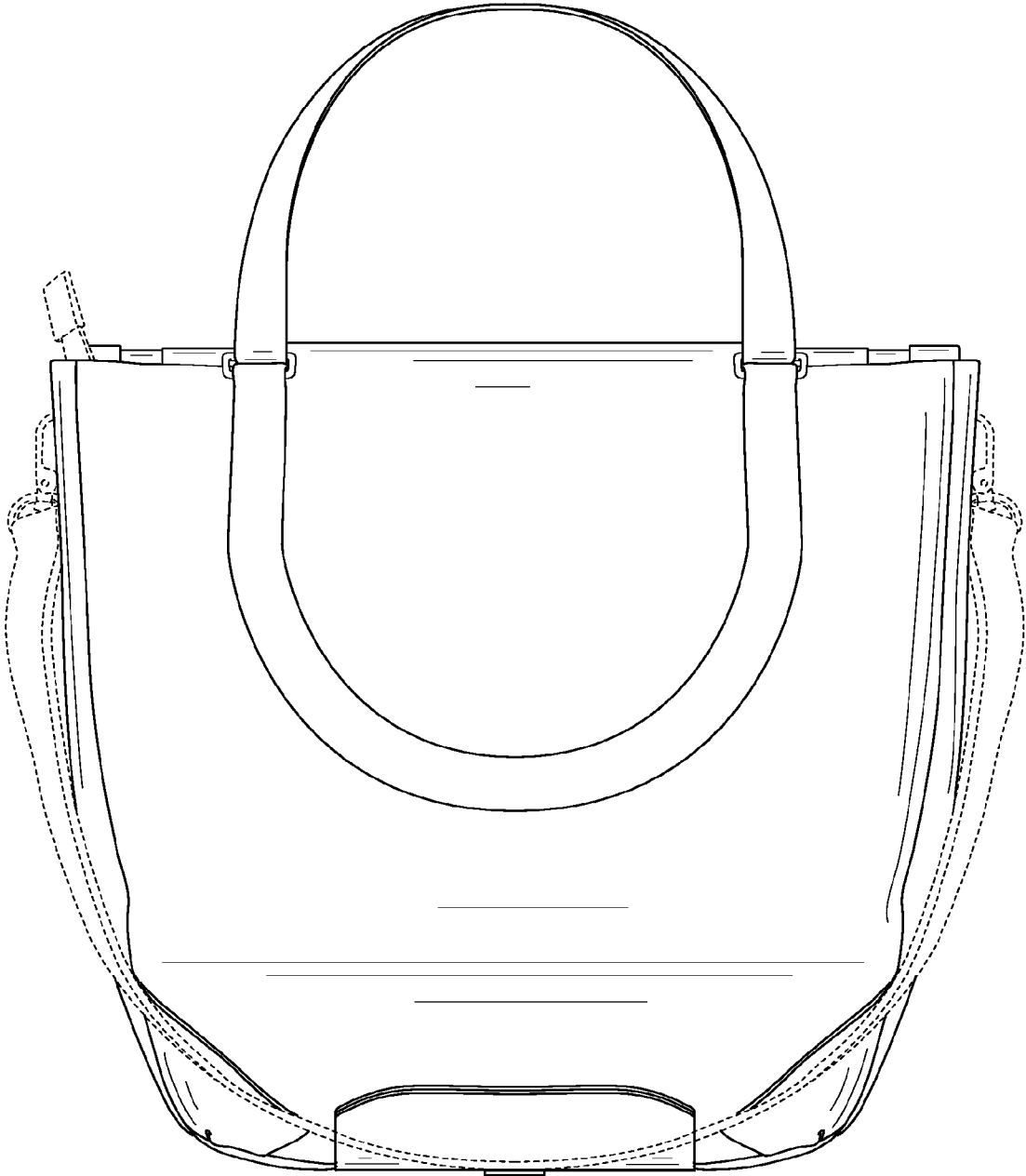

Fig. 17

310

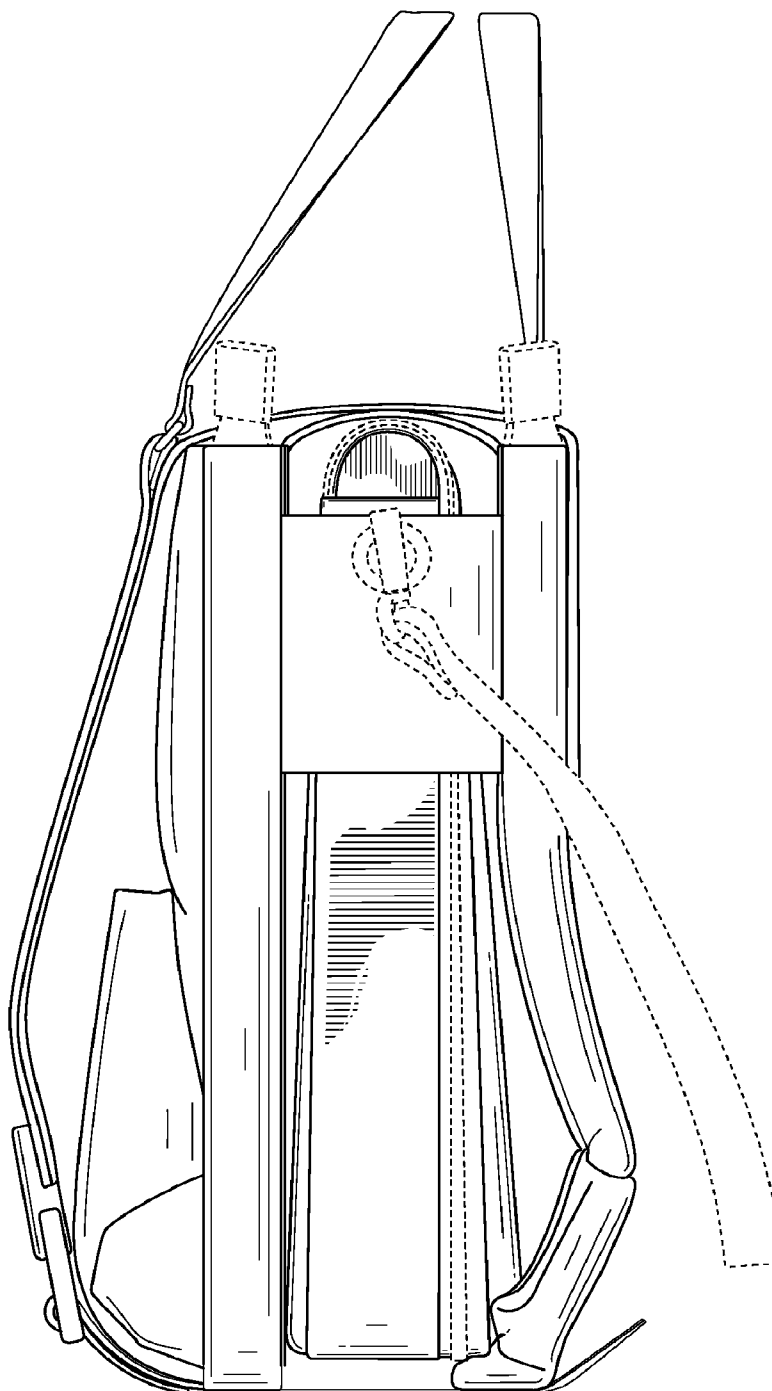

Fig. 18

310

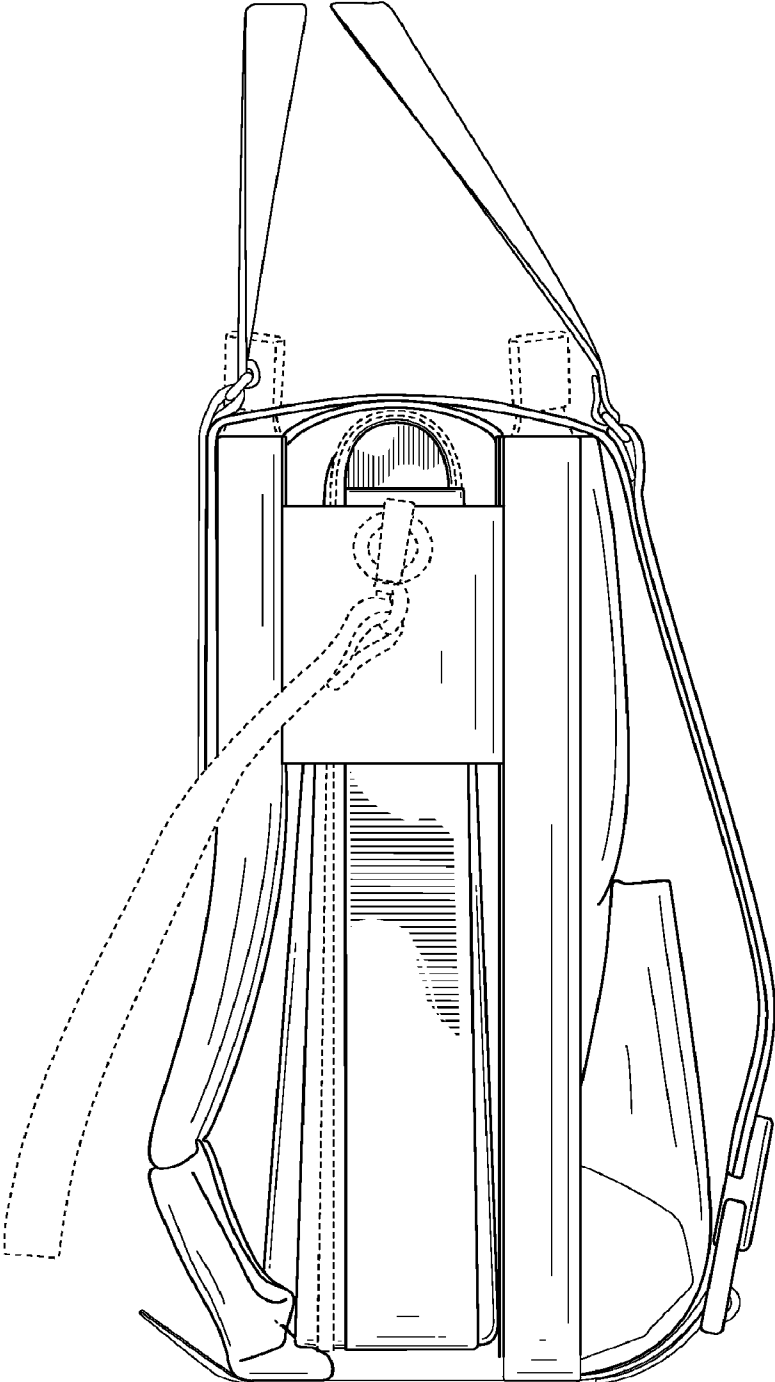

Fig. 19

310

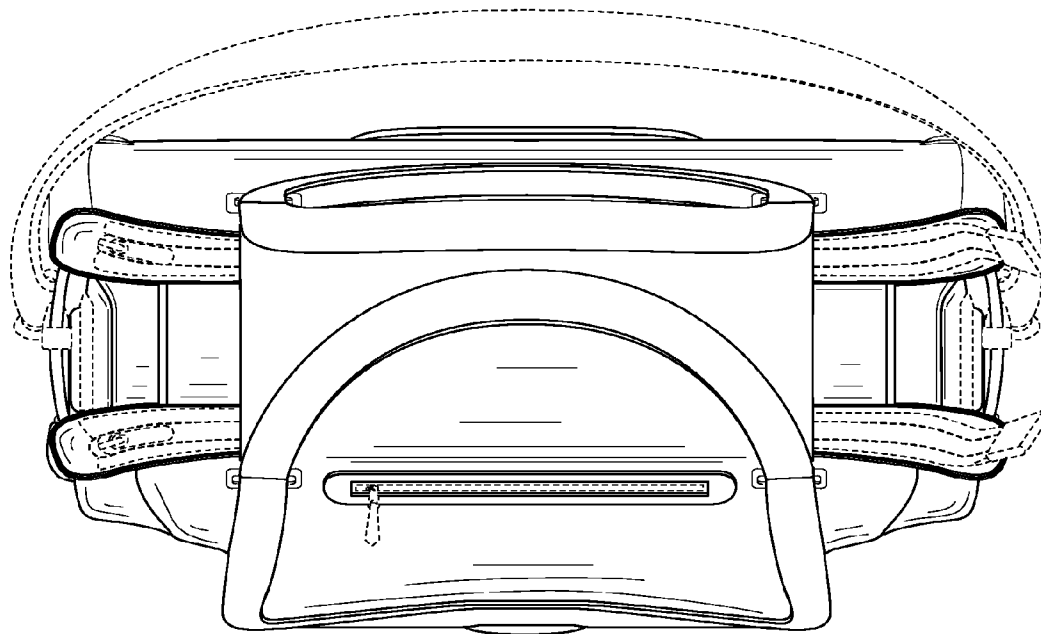

Fig. 20A

310

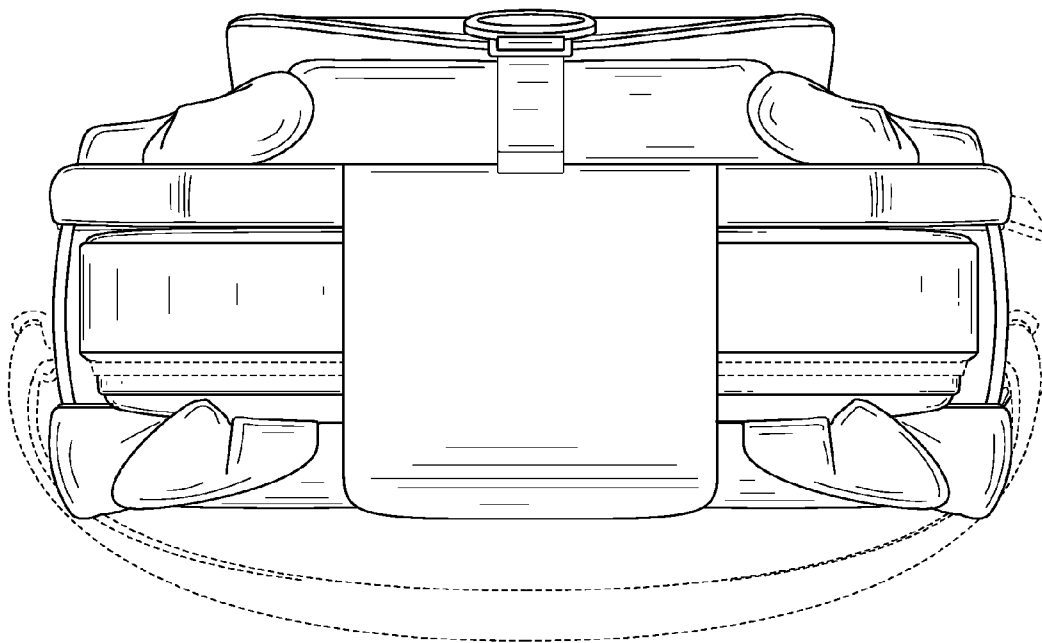

Fig. 20B

410

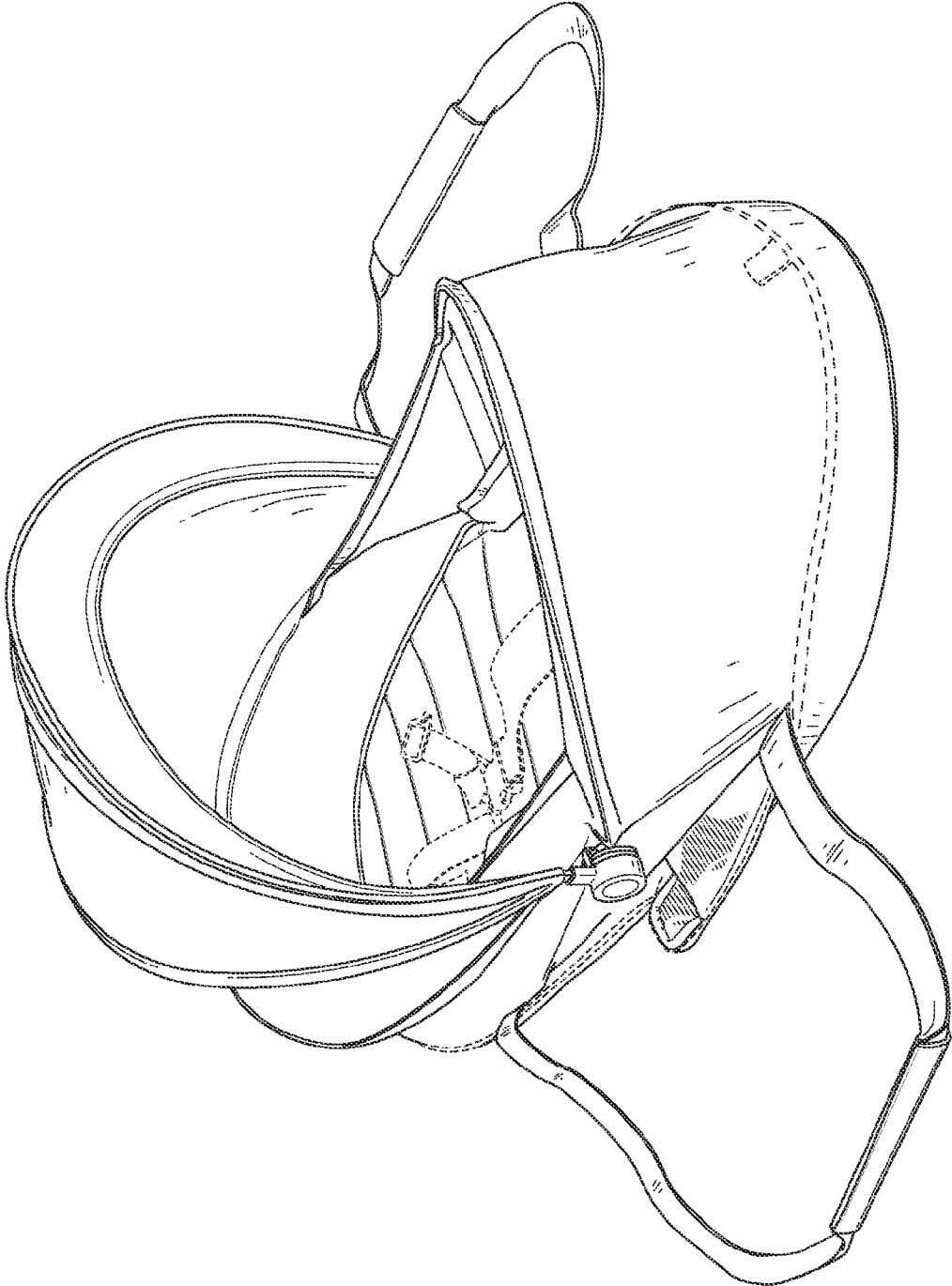

Fig. 21

410

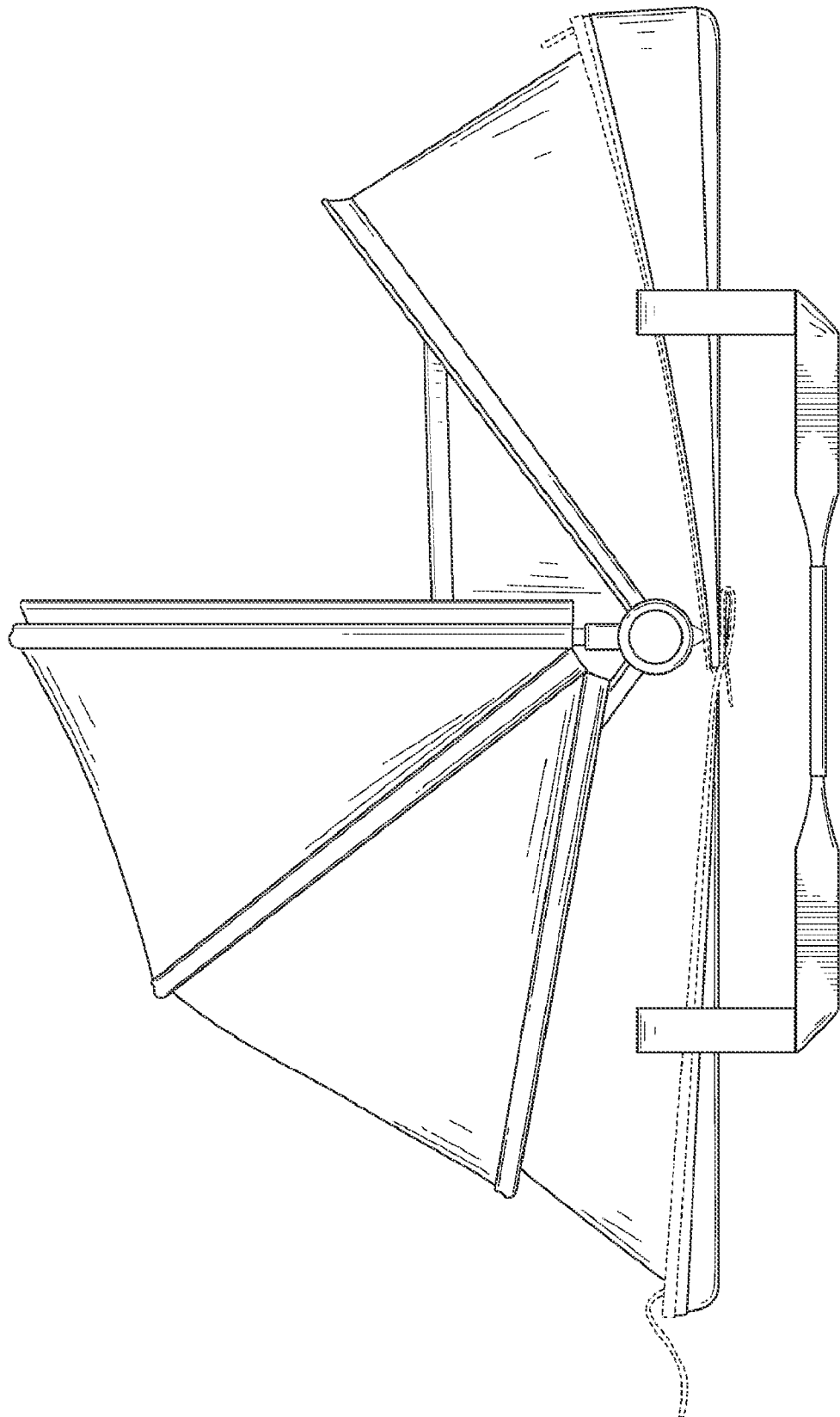

Fig. 22

410

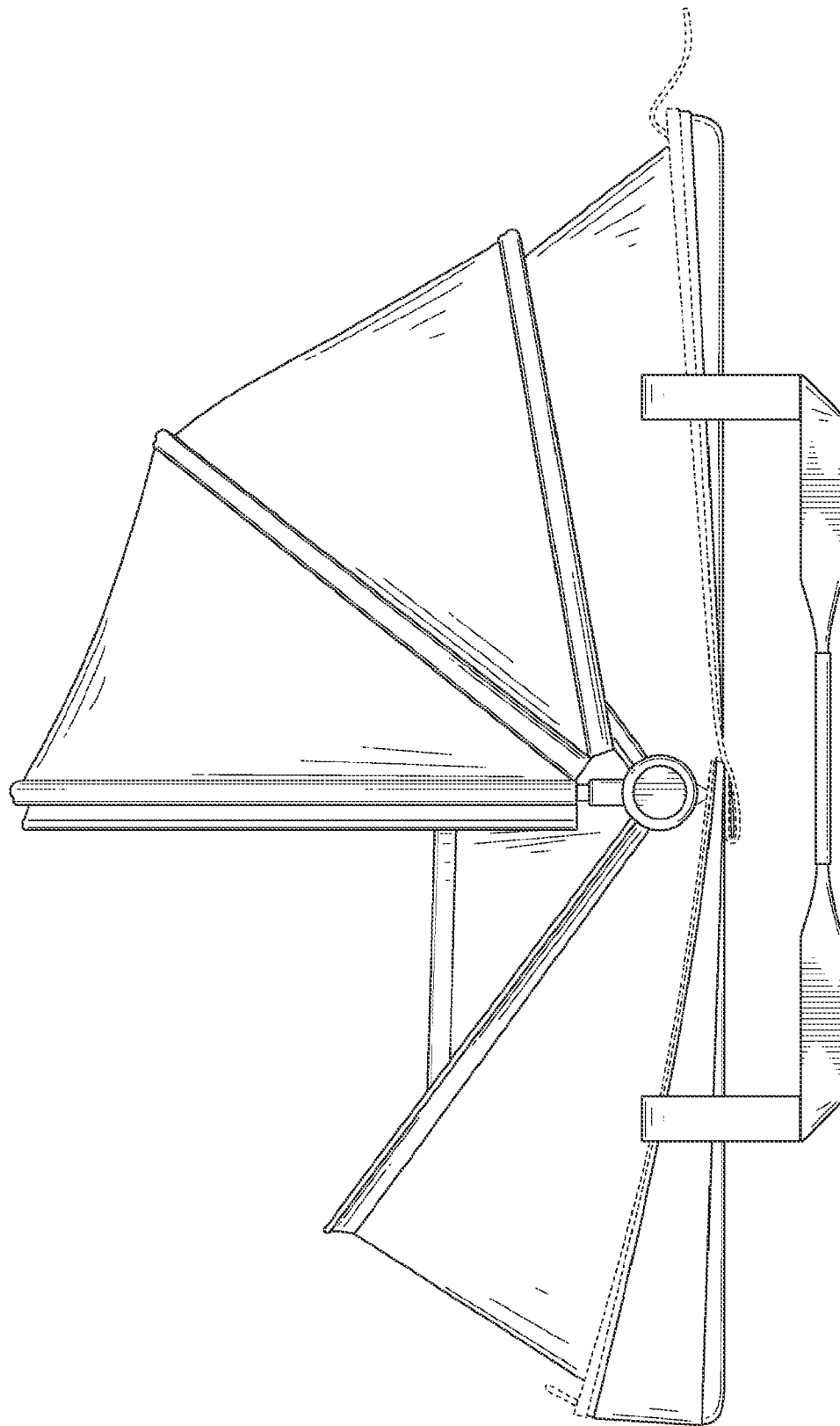

Fig. 23

410

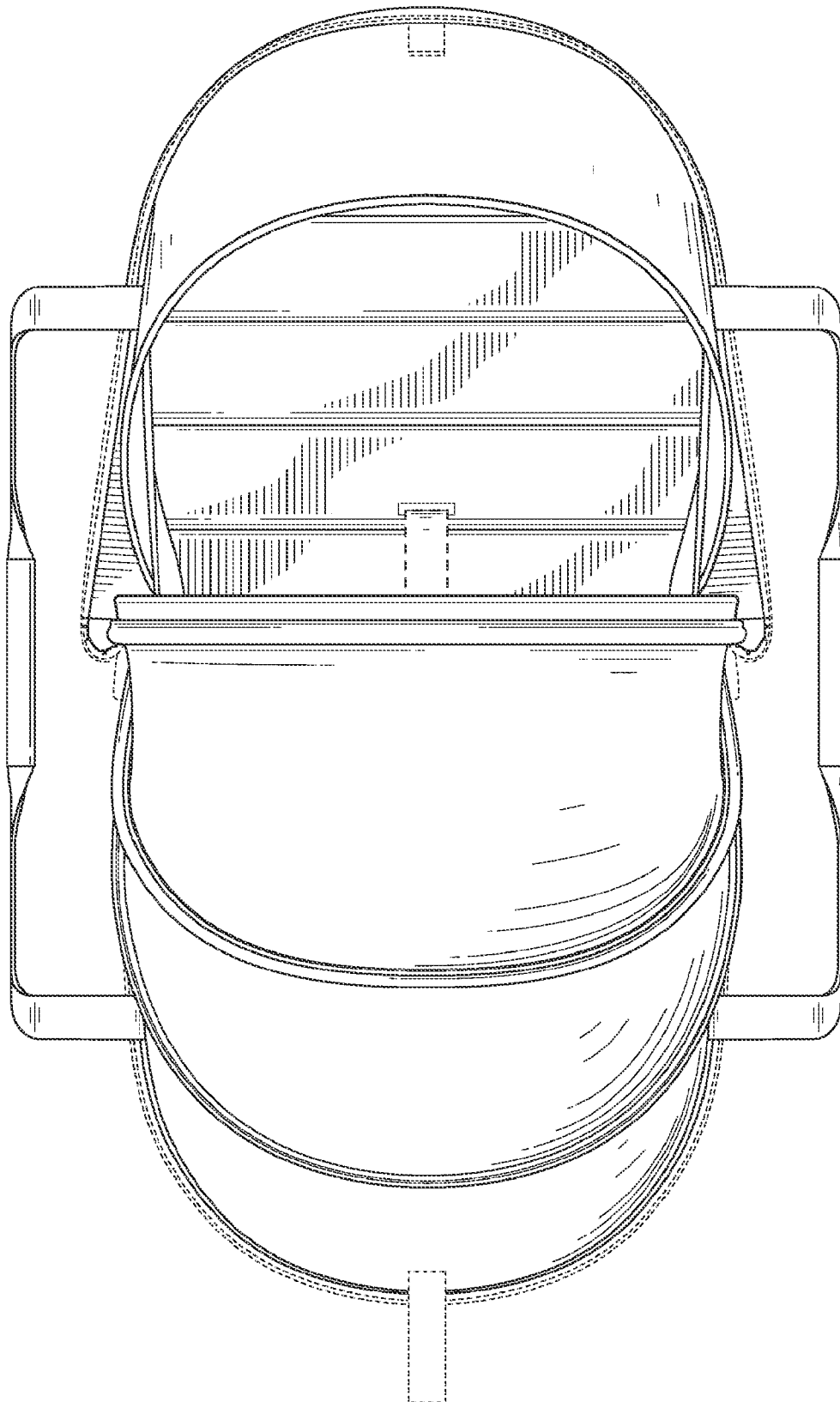

Fig. 24

410

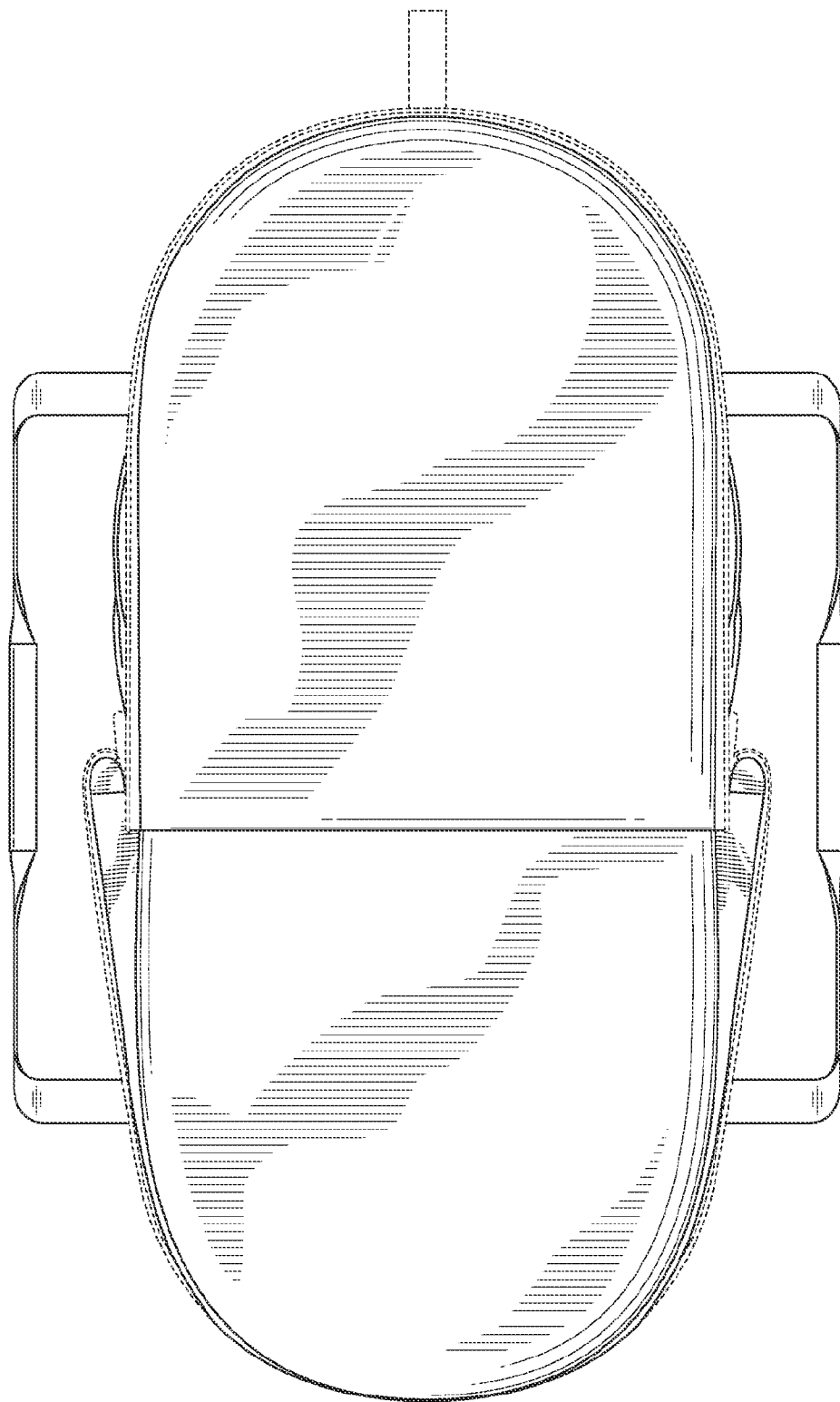

Fig. 25

410

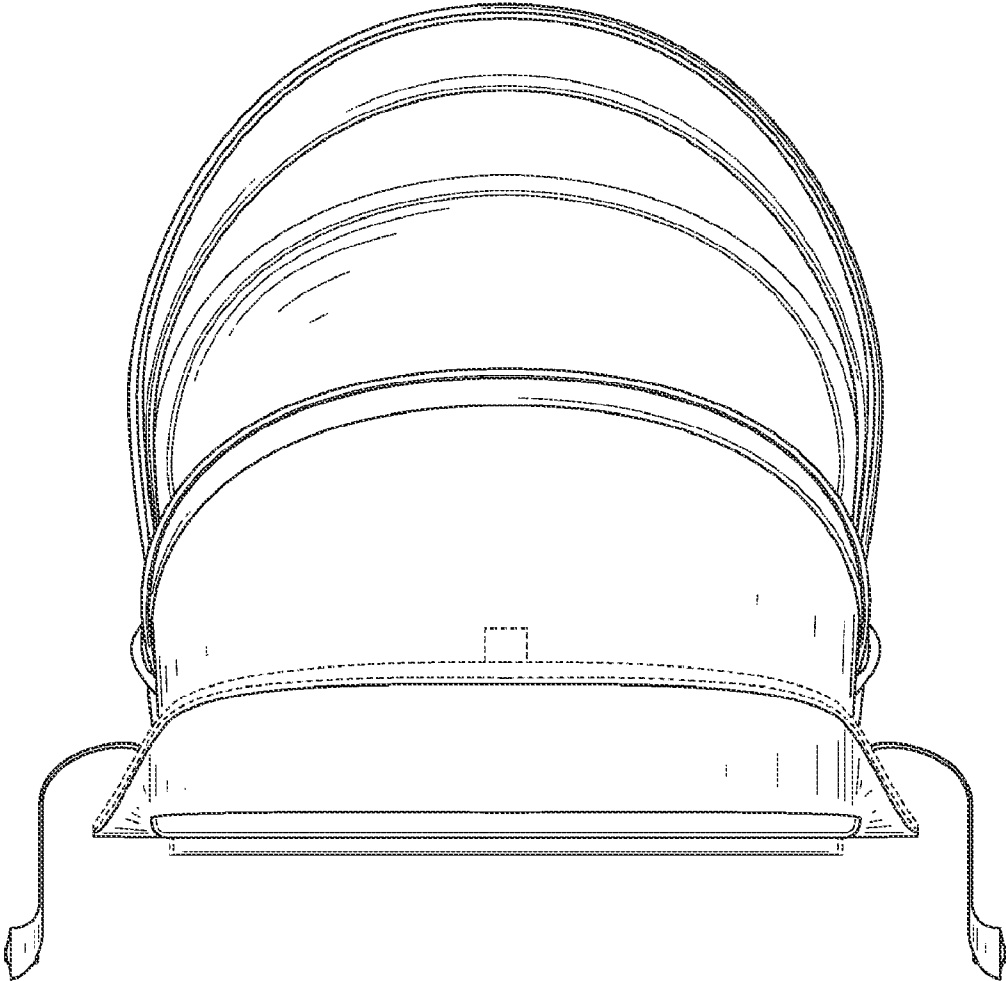

Fig. 26

410

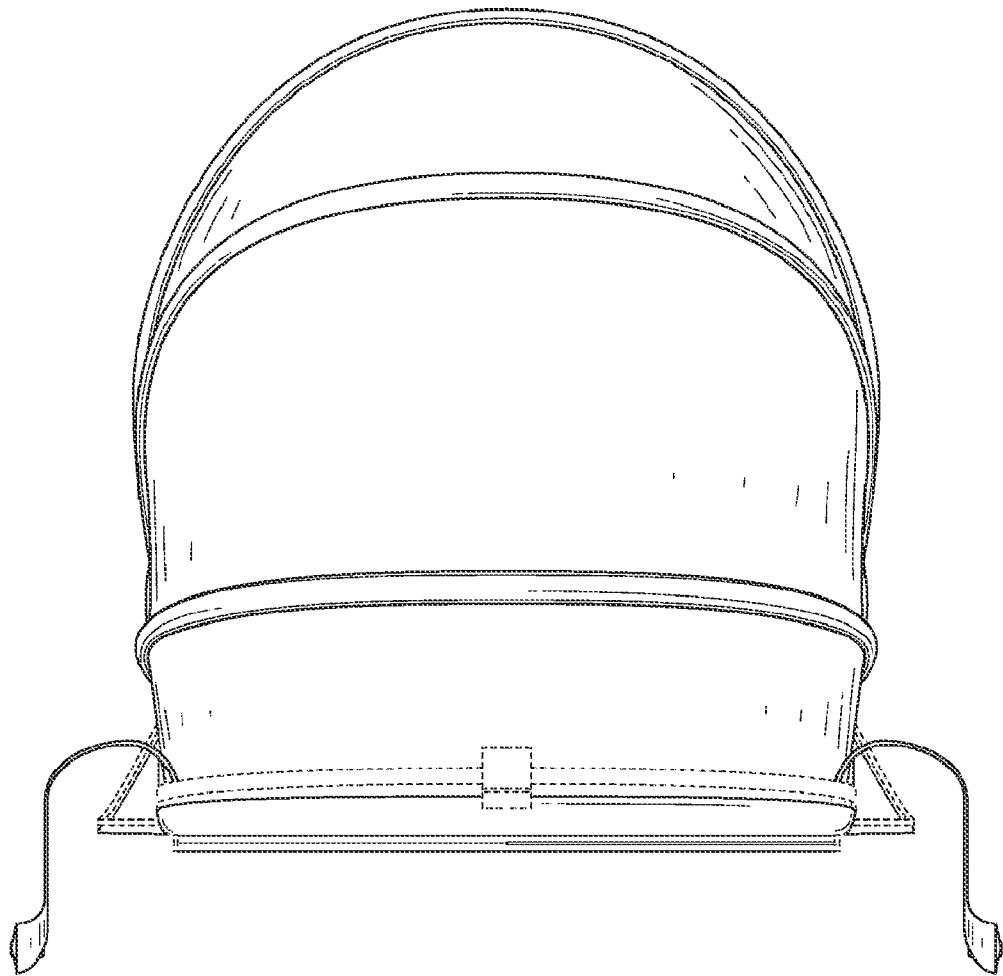

Fig. 27

410

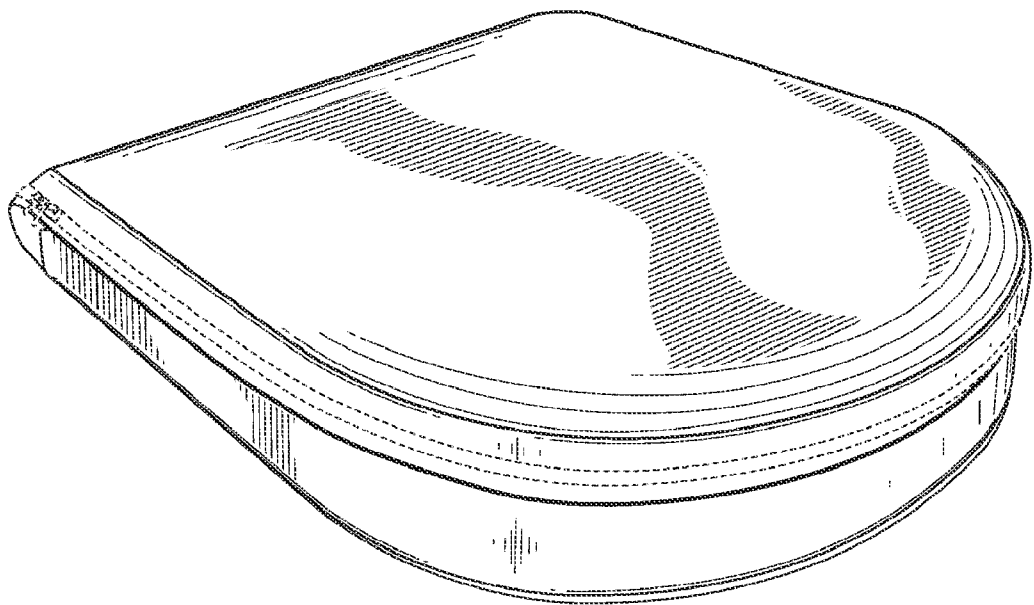

Fig. 28

410

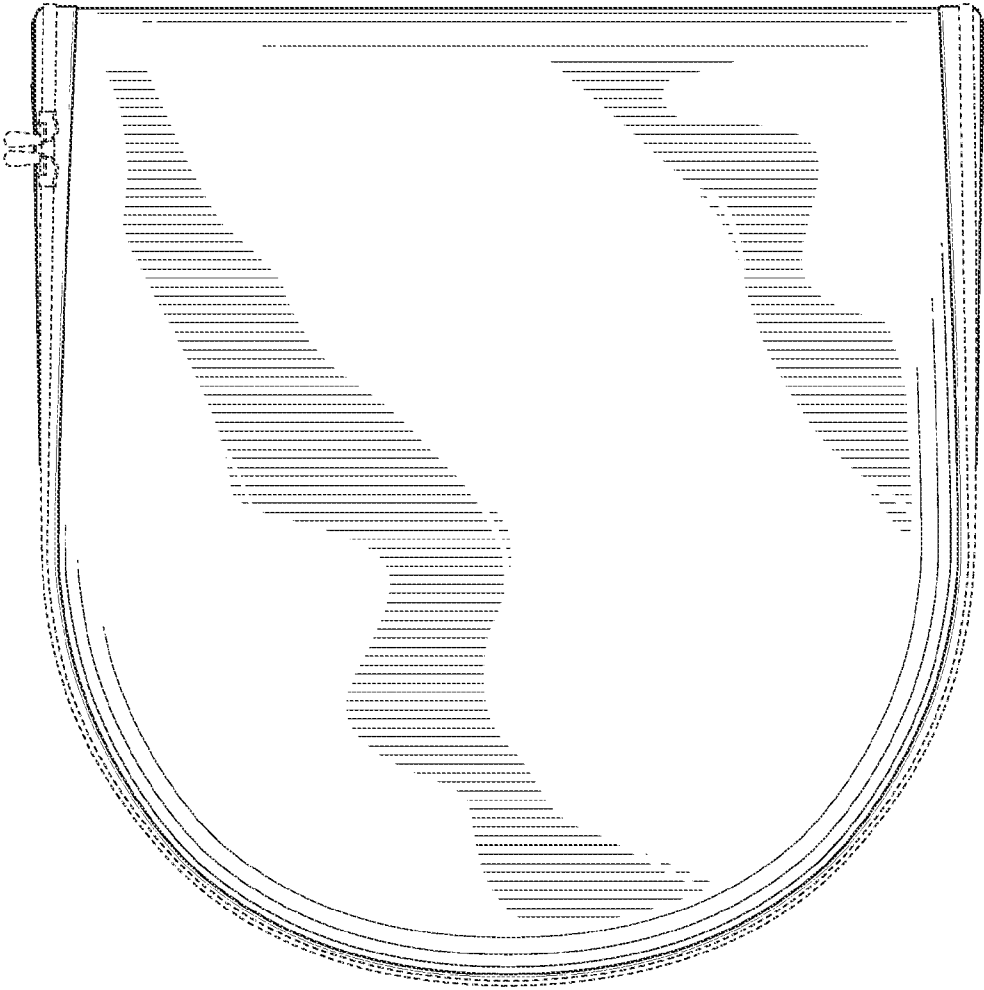

Fig. 29

410

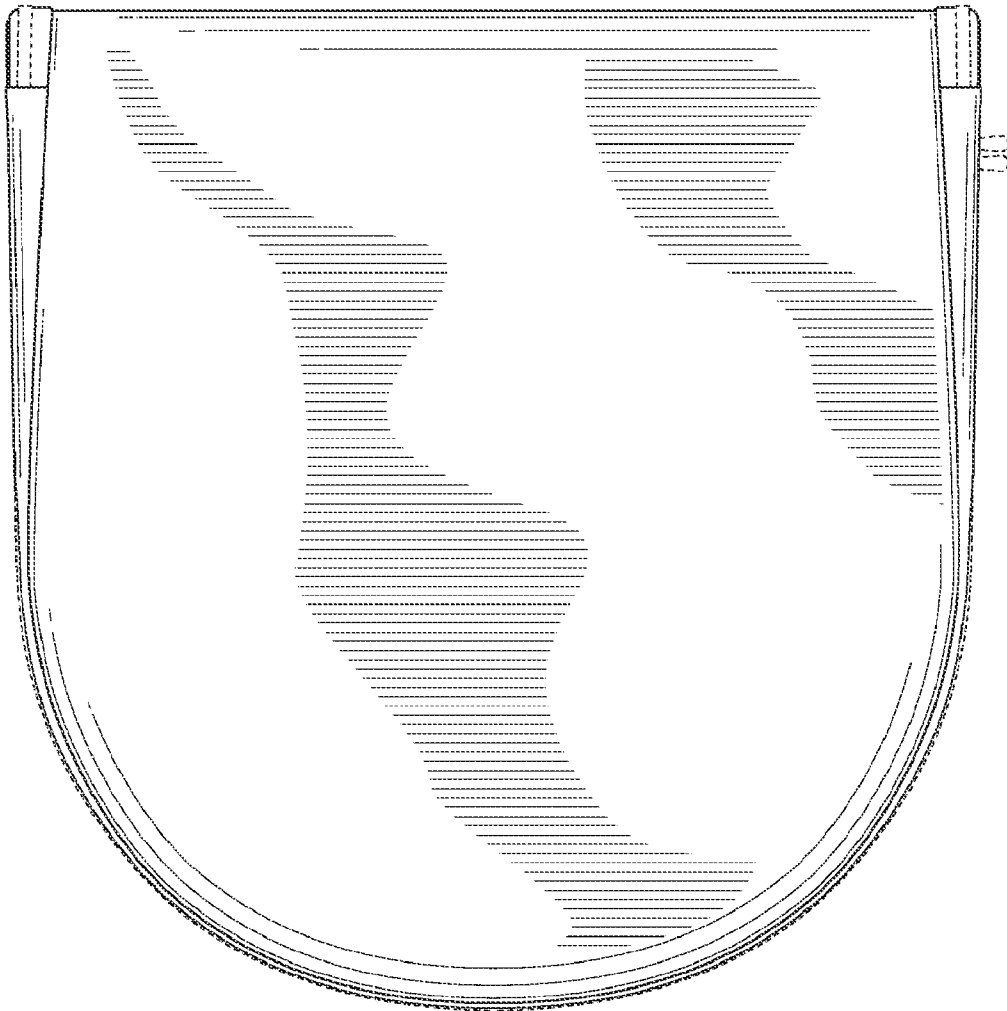

Fig. 30

410

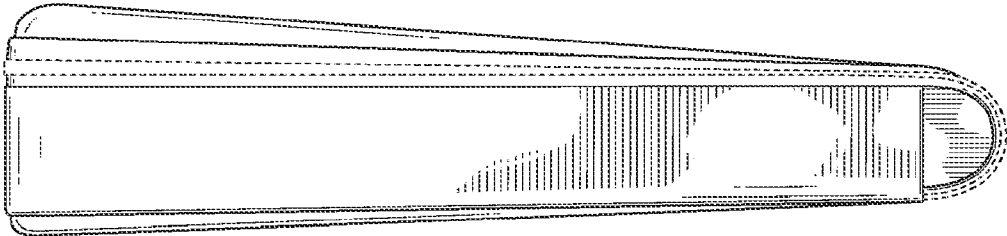

Fig. 31

410

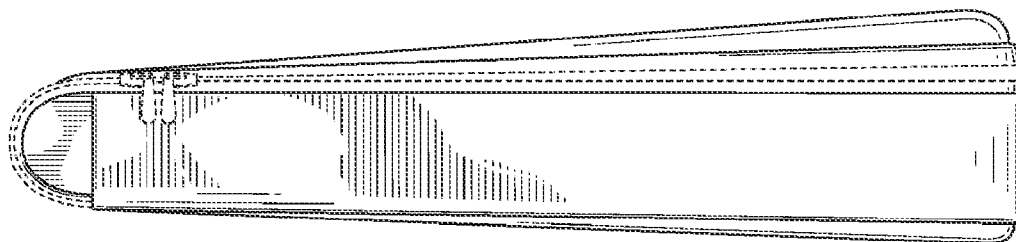

Fig. 32

410

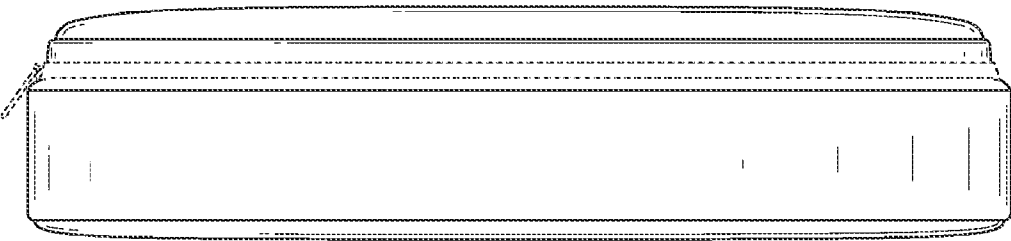

Fig. 33

410

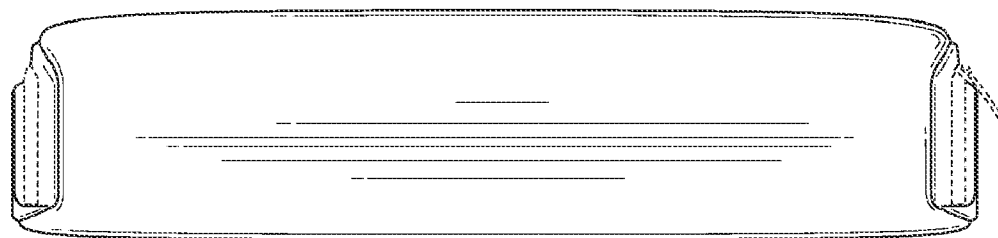

Fig. 34

510

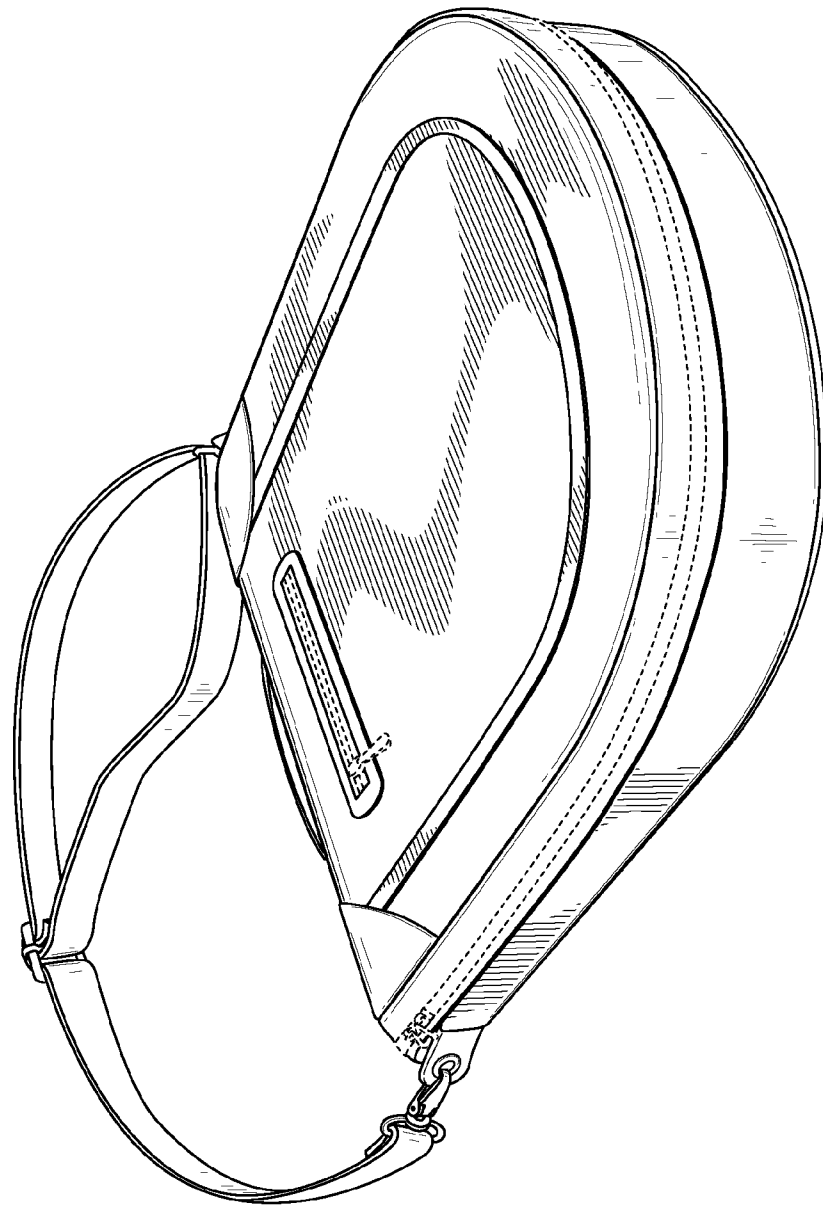

Fig. 35

510

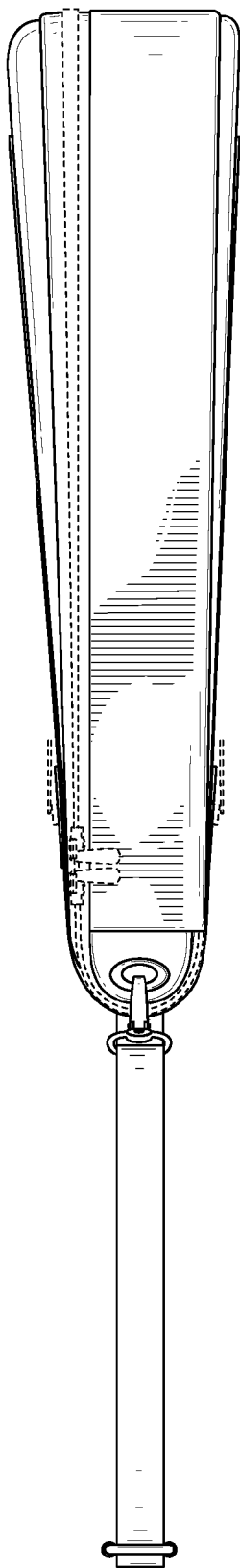

Fig. 36A

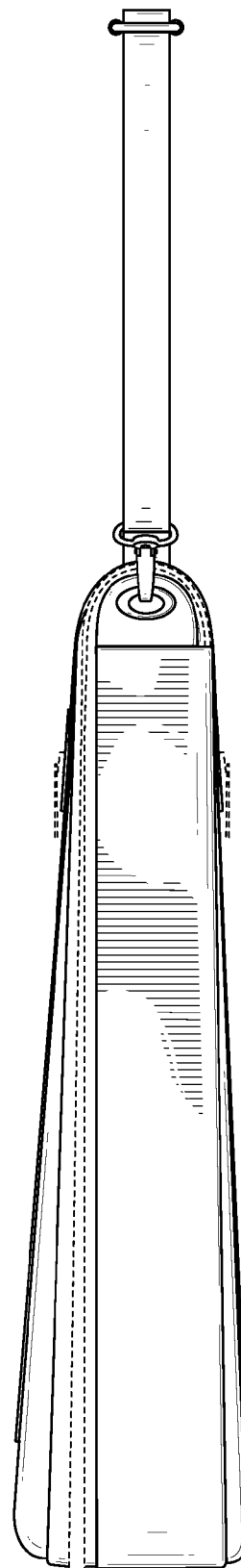

Fig. 36B

510

510

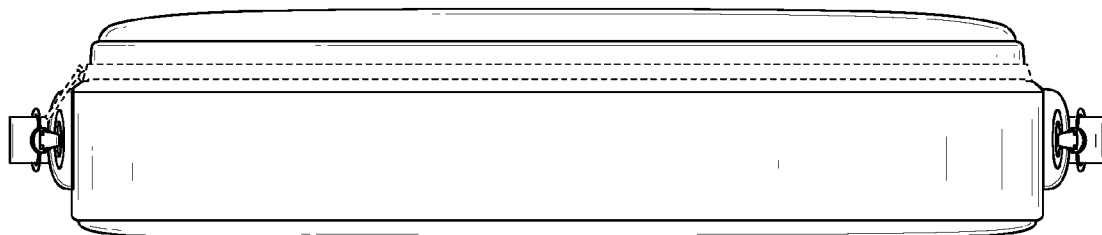

Fig. 37A

510

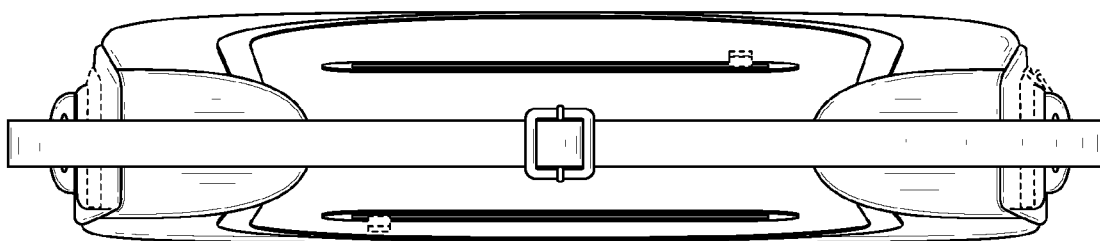

Fig. 37B

510

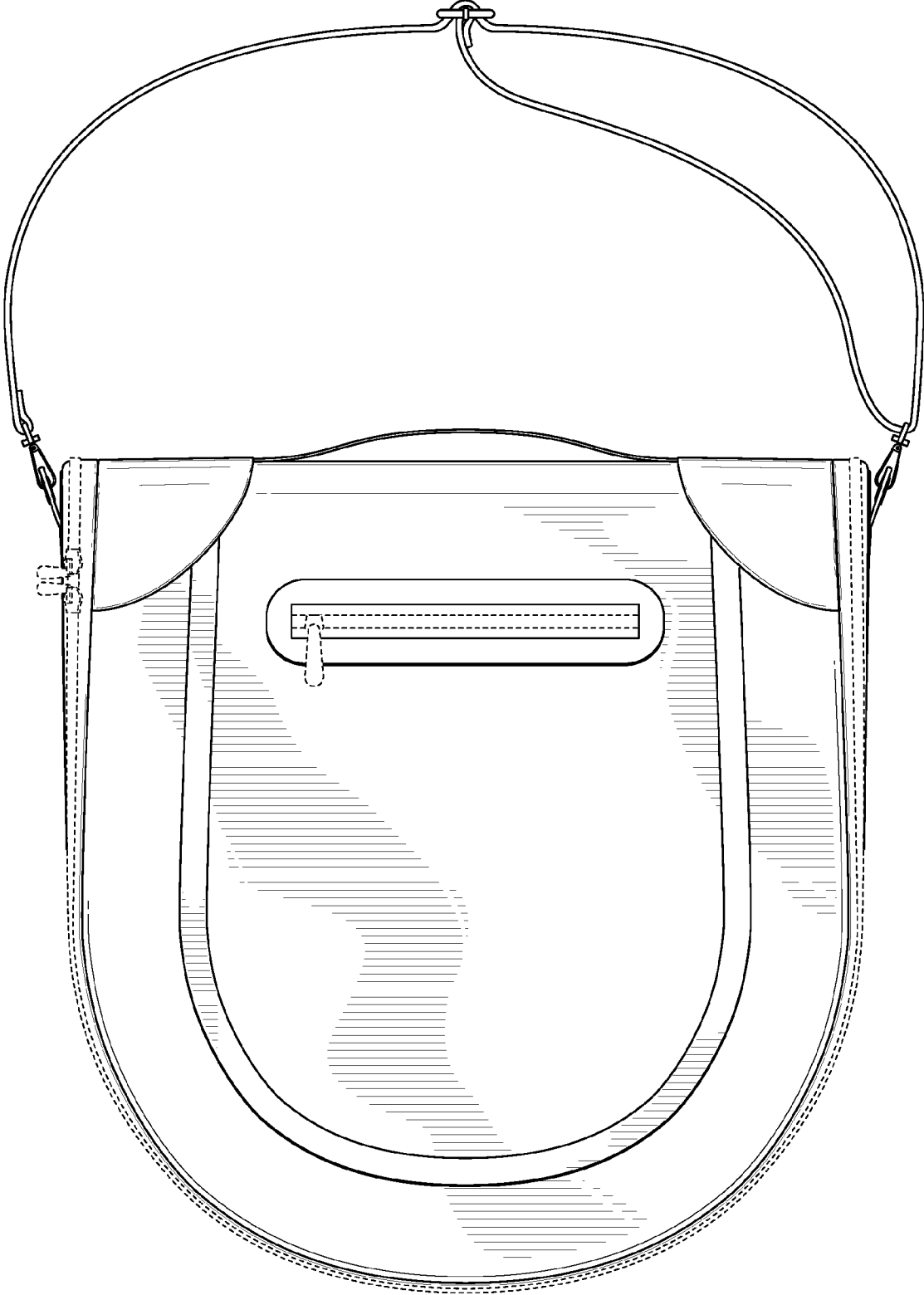

Fig. 38

510

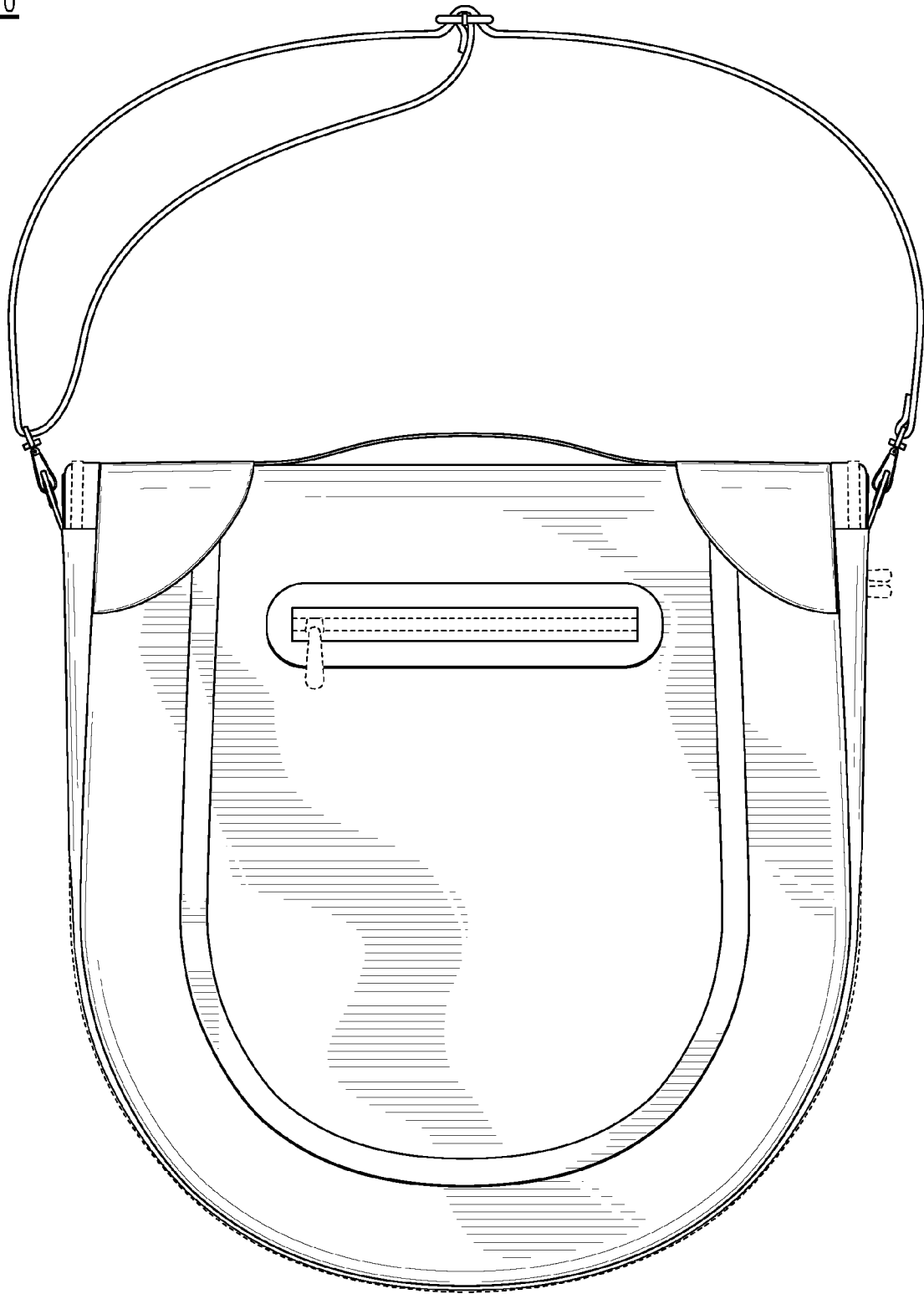

Fig. 39

510

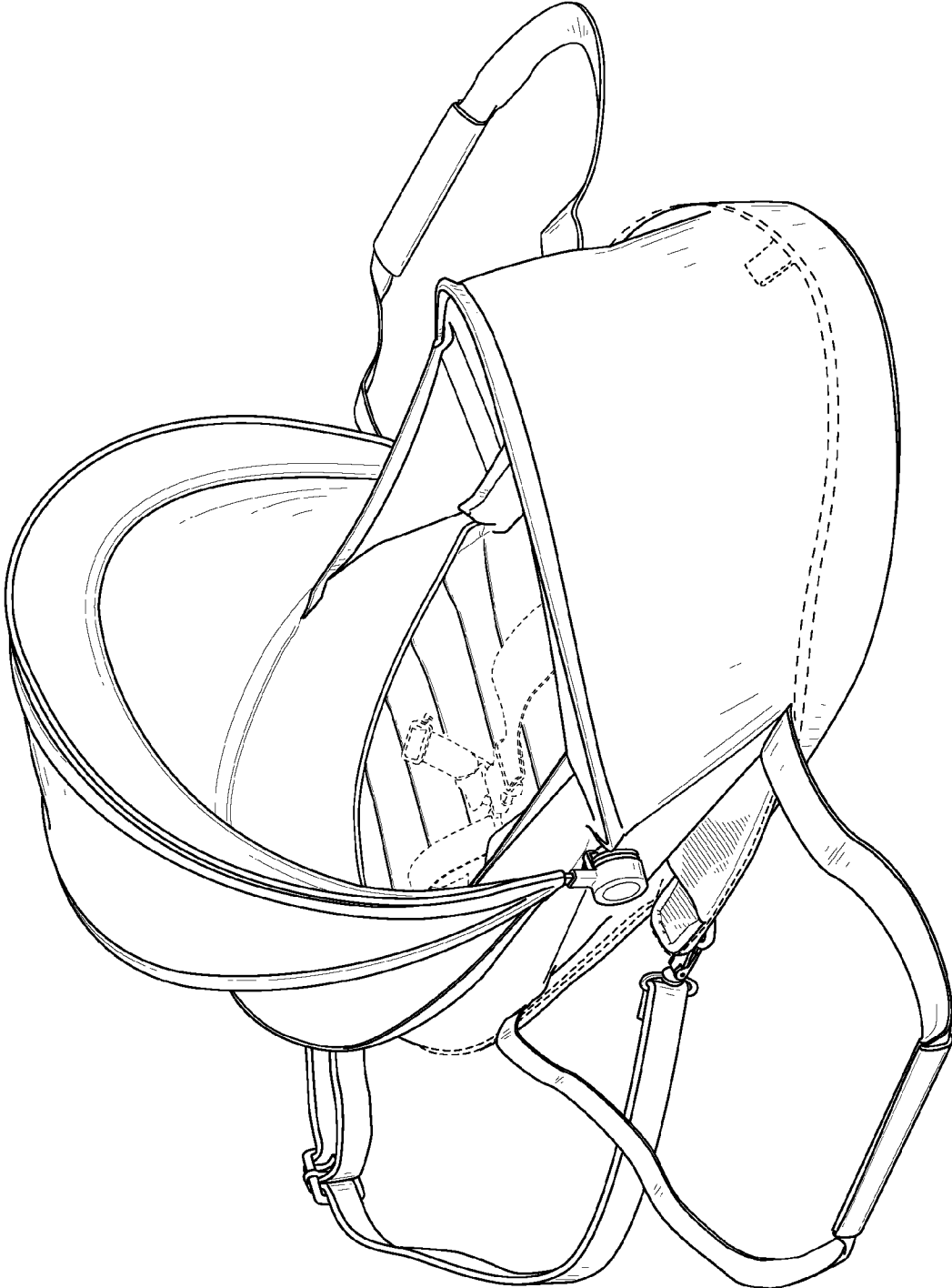

Fig. 40

510

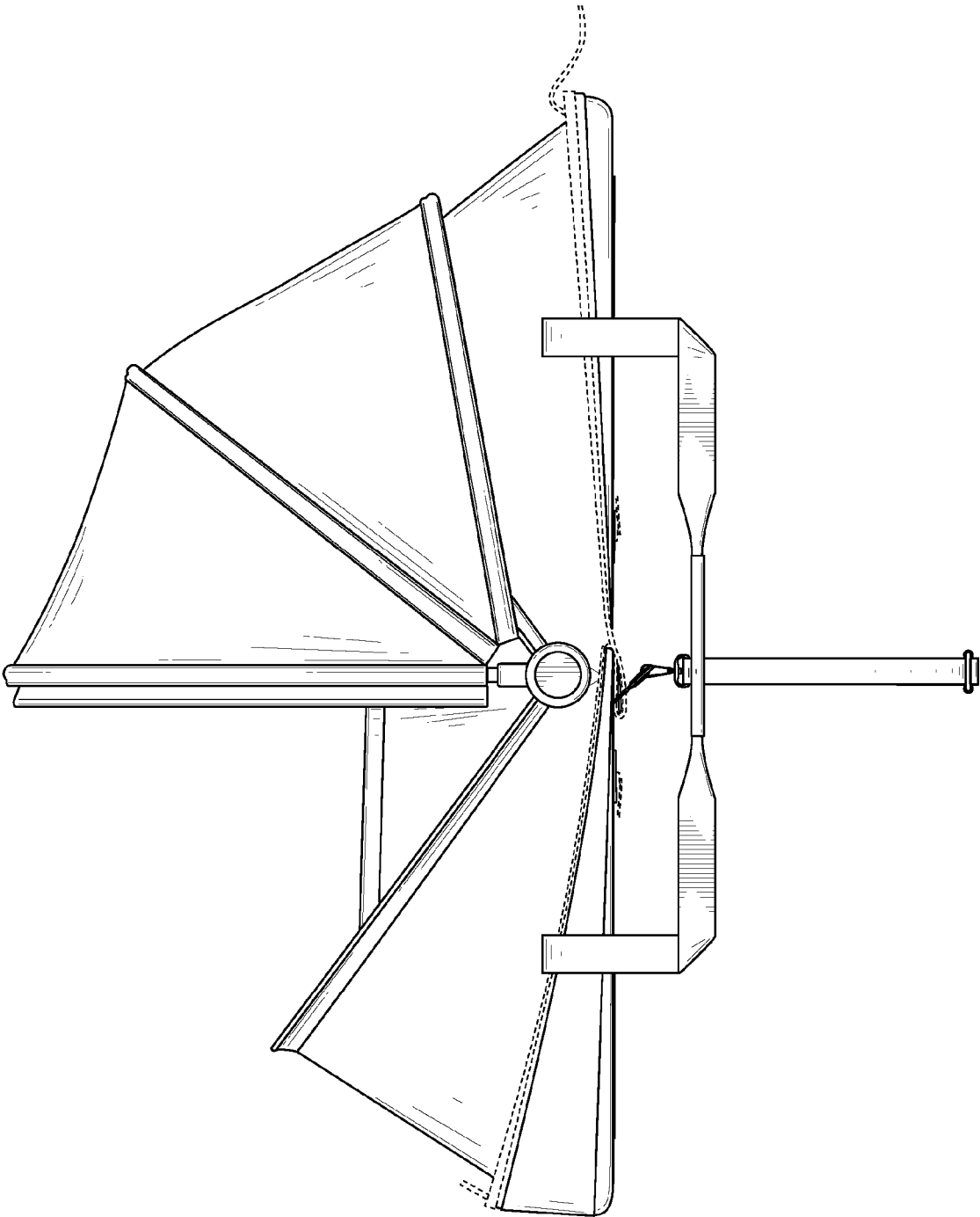

Fig. 41

510

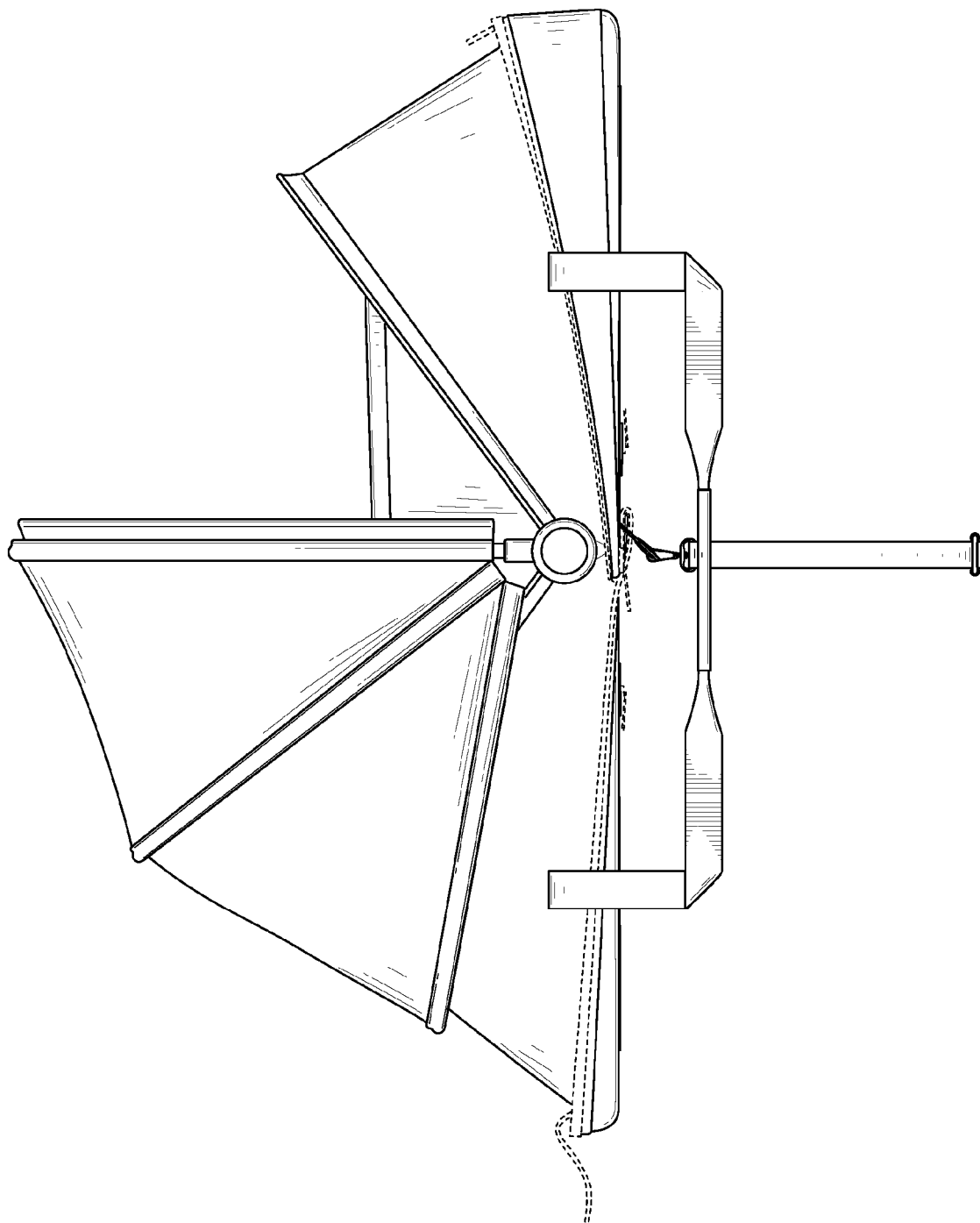

Fig. 42

510

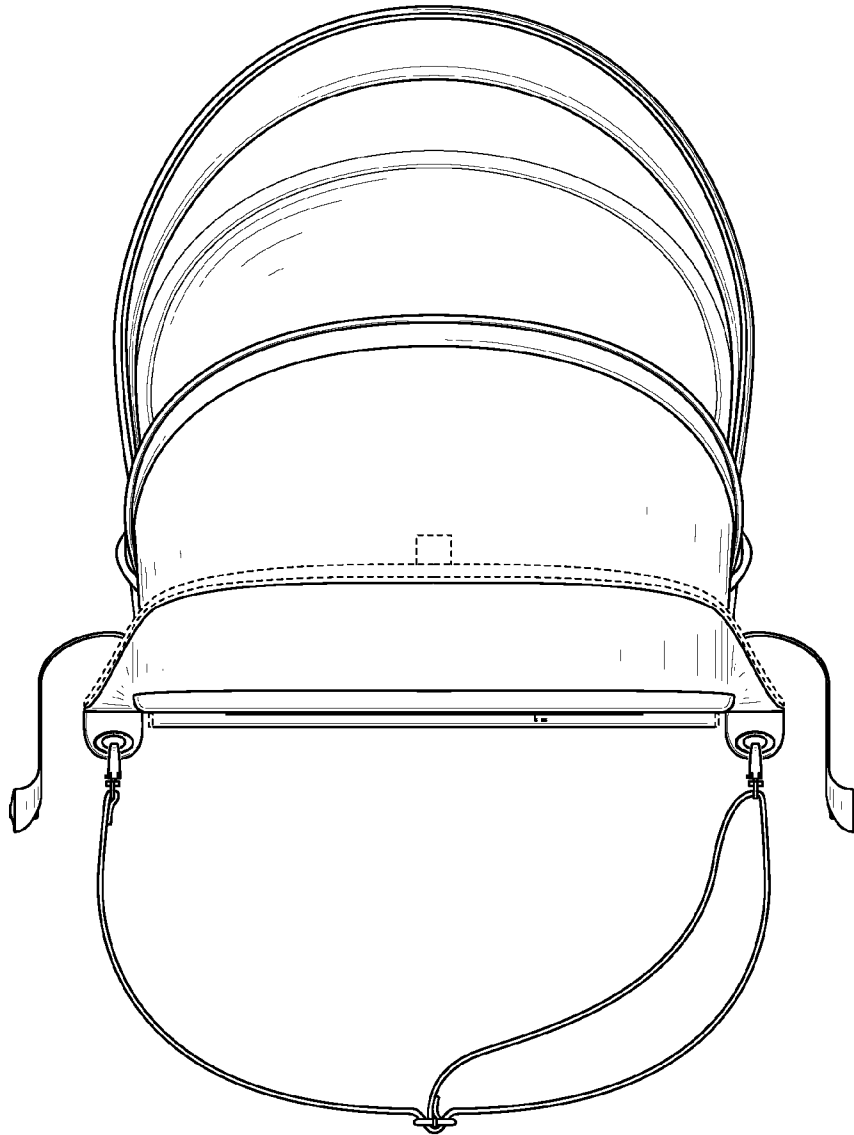

Fig. 43

510

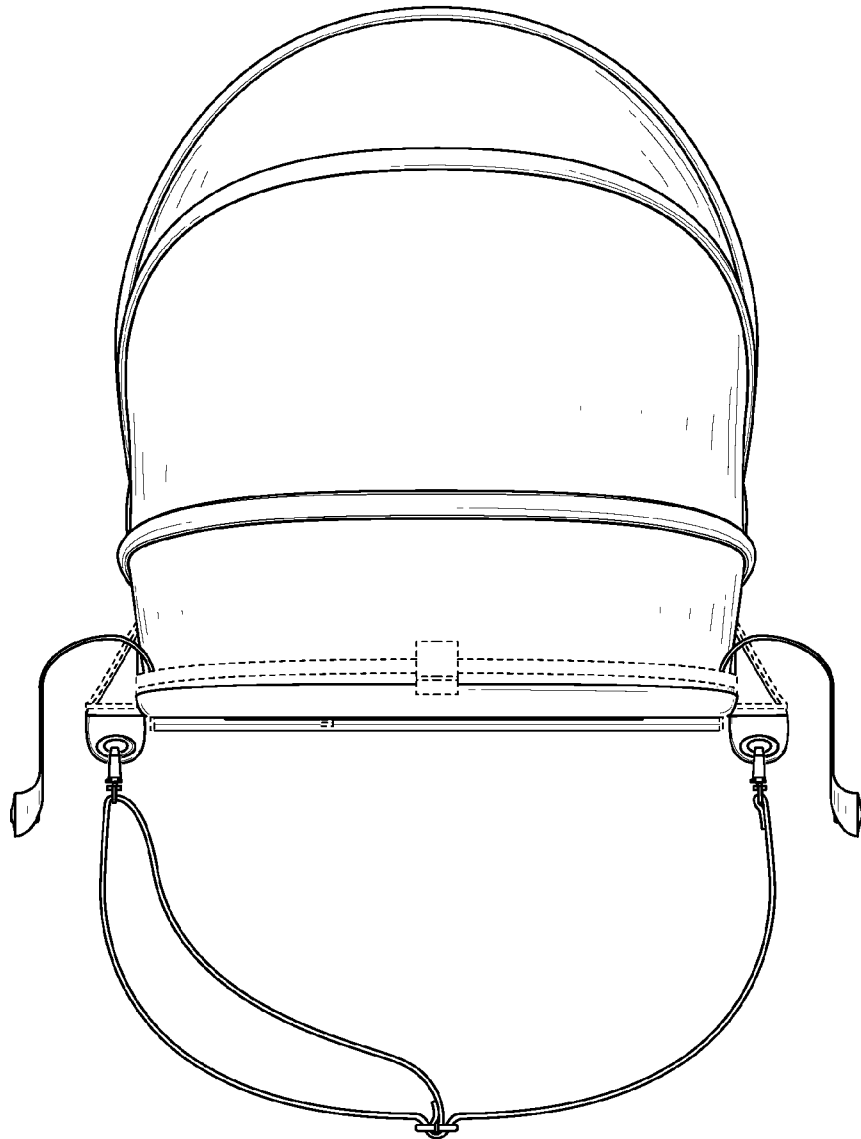

Fig. 44

510

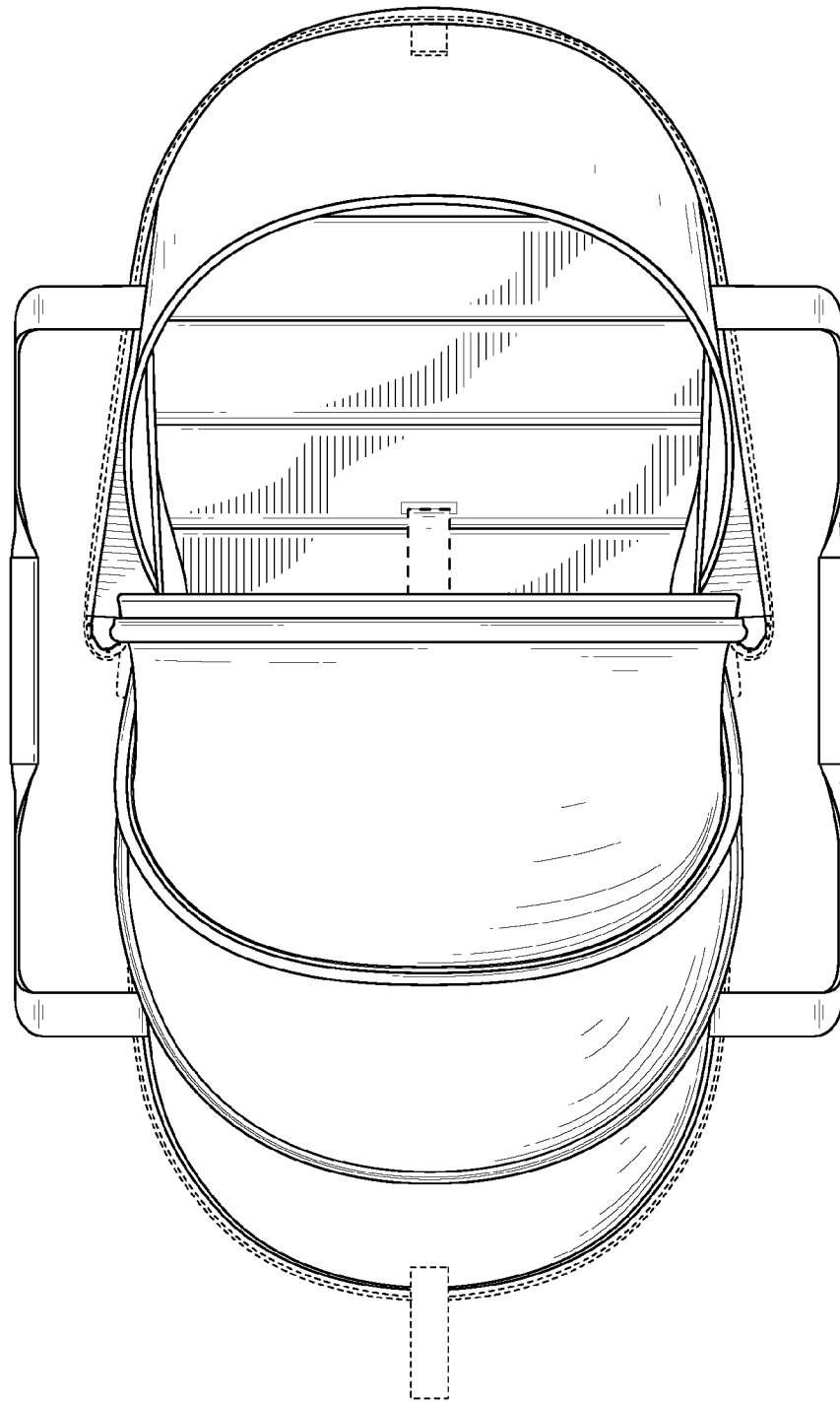

Fig. 45

510

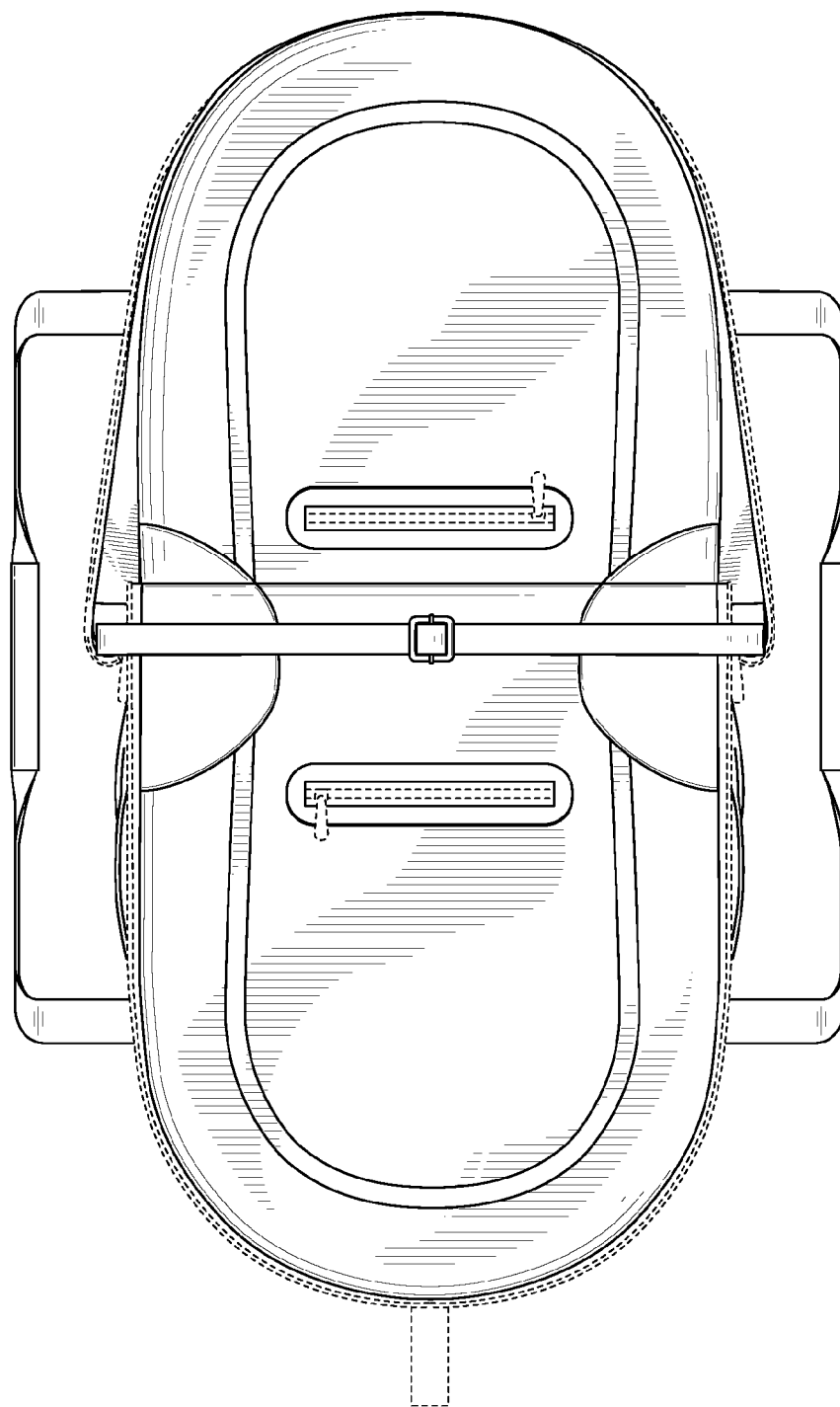

Fig. 46

BABY CARE ASSEMBLY

CROSS-REFERENCE TO RELATED APPLICATIONS

[0001] The present application is a U.S. nonprovisional patent application of, and claims priority under 35 U.S.C. § 119(e) to, each of U.S. provisional patent application serial number 60,983,921 filed Oct. 30, 2007, and U.S. provisional patent application serial number 61,026,475, filed Feb. 6, 2008, which provisional patent applications are each hereby incorporated herein by reference

COPYRIGHT STATEMENT

[0002] All of the material in this patent document is subject to copyright protection under the copyright laws of the United States and other countries. The copyright owner has no objection to the facsimile reproduction by anyone of the patent document or the patent disclosure, as it appears in official governmental records but, otherwise, all other copyright rights whatsoever are reserved.

BACKGROUND OF THE INVENTION

[0003] The present invention generally relates to baby bags and baby carriers, and more particularly, to a baby care assembly including a baby bag and baby carrier, wherein the baby bag is dimensioned for receipt and storage of the removable baby carrier when the baby carrier is not in use.

[0004] A variety of bags intended for use in carrying child-care accessories are commercially available. Available bags are useful for storing and transporting accessories and can be seen in many public environments where care providers such as parents and young children are seen. For example, young mothers carrying children and bags of diaper-changing supplies can often be seen in shopping districts, public parks, and in public transportation facilities. A care provider can face considerable physical prowess and balance challenges in carrying both a child and a typical care accessory bag throughout the course of any typical daily outing. Yet other challenges arise when a diaper needs to be changed. Even if a diaper changing station is available, such as in a public restroom, a parent may have difficulty while trying to comfort and securely hold a child on the hard surface of such a station while fumbling through a bag to find needed supplies. The cleanliness of such a surface and the overall public restroom environment is yet another concern for such a parent, and carrying a pad or the like to isolate the child and the supplies only adds further burden in carrying and placing the pad. Indeed, often are seen awkward ad hoc situations in automobiles and lobbies where diaper changing stations are unavailable and a care provider struggles to feed a child or change a diaper without a convenient platform for the execution of the task. Child carriers are available to securely cradle a child but typical carriers are fashioned such that a child essentially must be removed from the carrier for a diaper changing, further complicating the balancing and juggling actions of the care provider.

[0005] In addition, it is often the situation that a care provider will be in a location where there is not a convenient location for a child to take a nap or sleep when the child becomes tired, e.g., a park or a friend or relative's house that either does not have proper sleeping arrangements for a child or has a child that is using the child appropriate sleeping arrangements. In such situations, it would be beneficial to

have an easily transportable apparatus such as a bassinet in which the child could take a nap or sleep for the night if the childcare provider was traveling overnight with the child.

SUMMARY OF THE INVENTION

[0006] The present invention includes many aspects and features. Moreover, while many aspects and features relate to, and are described in, the context of baby bags and baby carriers, the present invention is not limited to use only in baby bags and baby carriers, as will become apparent from the following summaries and detailed descriptions of aspects, features, and one or more embodiments of the present invention.

[0007] Accordingly, one aspect of the present invention relates a baby care assembly. The baby care assembly includes a baby carrier positionable between two configurations an open, use configuration, wherein a baby may be placed in the carrier, and a closed, folded configuration; and a baby bag configured and dimensioned to receive and retain the baby carrier when the baby carrier is in the closed, folded configuration.

[0008] In a feature of this aspect of the invention, the baby bag includes a carrier receiving area for receiving and retaining the baby carrier.

[0009] In a feature of this aspect of the invention, the baby bag includes a receiving area closure panel for maintaining the baby carrier in the carrier receiving area.

[0010] In a feature of this aspect of the invention, the closure panel is disposed at a bottom of the baby bag.

[0011] In a feature of this aspect of the invention, the baby bag has a front section and a back section and the carrier receiving area is between the front and back sections of the baby bag.

[0012] In a feature of this aspect of the invention, a receiving area closure panel releasably connects the front section of the baby bag to the back section of the baby bag when it is engaged.

[0013] In a feature of this aspect of the invention, the baby bag includes an insulated pocket.

[0014] In a feature of this aspect of the invention, the baby bag includes a detachable shoulder strap.

[0015] In a feature of this aspect of the invention, the baby bag includes grasping handles.

[0016] In a feature of this aspect of the invention, the baby carrier includes a base, opposing sides, and opposing ends.

[0017] In a feature of this aspect of the invention, the baby carrier includes end and side walls that extend upwardly away from the base when the baby carrier is in the open, use configuration and that fold into the carrier when the carrier is in the closed, folded configuration.

[0018] In a feature of this aspect of the invention, the baby carrier includes a removable base pad.

[0019] In a feature of this aspect of the invention, the baby carrier includes a pair of centrally-disposed, grasping handles, one on each side of the baby carrier.

[0020] In a feature of this aspect of the invention, the handles are folded into the baby carrier when the baby carrier is in the closed, folded configuration.

[0021] In a feature of this aspect of the invention, the baby carrier includes a closure mechanism at a periphery thereof for securing the baby carrier in the closed, folded configuration.

[0022] In a feature of this aspect of the invention, the closure mechanism is a zipper.

[0023] In a feature of this aspect of the invention, the baby carrier includes a canopy having a leading edge supported by an internal support strip.

[0024] In a feature of this aspect of the invention, when the baby carrier is in the open, use configuration, the canopy is positionable between a relaxed position, wherein the canopy, including the internal support strip, is folded against a peripheral wall of the baby carrier at a first end thereof and a covering position, wherein the canopy is stretched across an interior of the baby carrier such that the internal support strip is abutting the peripheral wall of the baby carrier on an end opposite the first end.

[0025] In a feature of this aspect of the invention, the canopy is positionable at intermediate positions between the relaxed position and the covering position.

[0026] In a feature of this aspect of the invention, a first intermediate position is defined by the internal support strip being disposed at a 15° increment relative to its location in the relaxed position and each subsequent intermediate position is defined by the internal support strip being disposed at a 15° increment relative to its location in the previous intermediate position until the canopy reaches the covering position.

[0027] In a feature of this aspect of the invention, intermediate positioning is enabled by a ratchet mechanism.

[0028] In a feature of this aspect of the invention, the baby carrier includes a safety release feature that prevents lifting of the baby carrier by the canopy.

[0029] In a feature of this aspect of the invention, the canopy is releasably connected to the baby carrier such that the canopy orientation may be inverted relative to the baby carrier.

[0030] In a feature of this aspect of the invention, the baby carrier includes a hinged platform.

[0031] In a feature of this aspect of the invention, the hinged platform includes two sub-platforms hingedly connected to one another, each sub-platform including a planar front face and a perimeter, with linear portions of the sub-platform perimeters being arranged in abutting relation to one another when the hinged platform is assembled.

[0032] In a feature of this aspect of the invention, the two sub-platforms are disposed in the same horizontal plane such that the front faces of the sub-platform are approximately 180° from one another when the baby carrier is in the open, use configuration.

[0033] In a feature of this aspect of the invention, the two sub-platforms are disposed with front faces thereof adjacent one another when the baby carrier is in the closed, folded configuration.

[0034] In a feature of this aspect of the invention, the hinged platform includes a hinge mechanism that prevents the hinged platform, when the baby carrier is in the open, use configuration, from folding together into the closed, folded configuration unless the hinge mechanism is actuated.

[0035] In a feature of this aspect of the invention, the hinge mechanism includes a latch that prevents inadvertent folding of the carrier.

[0036] In a feature of this aspect of the invention, the hinge assembly includes hinge plates that prevent inadvertent folding of the carrier.

[0037] In a feature of this aspect of the invention, the hinged platform includes a hinge mechanism that prevents the hinged platform, when the baby carrier is in the open, use configuration, from over extending.

[0038] Another aspect of the present invention relates to a baby carrier. The baby carrier includes a base, opposing sides, and opposing ends and being positionable between two configurations an open, use configuration, wherein a baby may be placed in the carrier, and a closed, folded configuration.

[0039] In a feature of this aspect of the invention, the baby carrier includes end walls and side walls that extend upwardly away from the base when the baby carrier is in the open, use configuration and that fold into the carrier when the carrier is in the closed, folded configuration.

[0040] In a feature of this aspect of the invention, the baby carrier includes a removable base pad.

[0041] In a feature of this aspect of the invention, the baby carrier includes a pair of centrally-disposed grasping handles, one on each side of the baby carrier.

[0042] In a feature of this aspect of the invention, the handles are folded into the baby carrier when the baby carrier is in the closed, folded configuration.

[0043] In a feature of this aspect of the invention, the baby carrier includes a closure mechanism at a periphery thereof for securing the baby carrier in the closed, folded configuration.

[0044] In a feature of this aspect of the invention, the closure mechanism is a zipper.

[0045] In a feature of this aspect of the invention, the baby carrier includes a canopy having a leading edge supported by an internal support strip.

[0046] In a feature of this aspect of the invention, when the baby carrier is in the open, use configuration, the canopy is positionable between a relaxed position, wherein the canopy, including the internal support strip, is folded against a peripheral wall of the baby carrier at a first end thereof and a covering position, wherein the canopy is stretched across an interior of the baby carrier such that the internal support strip is abutting the peripheral wall of the baby carrier on an end opposite the first end.

[0047] In a feature of this aspect of the invention, the canopy is positionable at intermediate positions between the relaxed position and the covering position.

[0048] In a feature of this aspect of the invention, a first intermediate position is defined by the internal support strip being disposed at a 15° increment relative to its location in the relaxed position and each subsequent intermediate position is defined by the internal support strip being disposed at a 15° increment relative to its location in the previous intermediate position until the canopy reaches the covering position.

[0049] In a feature of this aspect of the invention, intermediate positioning is enabled by a ratchet mechanism.

[0050] In a feature of this aspect of the invention, the baby carrier includes a safety release feature that prevents the baby carrier from being lifted by the canopy or the internal support strip of the canopy.

[0051] In a feature of this aspect of the invention, the canopy is releasably connected to the baby carrier such that the canopy orientation may be inverted relative to the baby carrier.

[0052] In a feature of this aspect of the invention, the baby carrier includes an internal hinged platform.

[0053] In a feature of this aspect of the invention, the hinged platform includes two sub-platforms hingedly connected to one another, each sub-platform including a planar front and a perimeter, with linear portions of the sub-platform perimeters arranged in abutting relation to one another when the hinged platform is assembled.

[0054] In a feature of this aspect of the invention, the two sub-platforms are disposed in the same horizontal plane such that the front faces of the sub-platform are approximately 180° from one another when the baby carrier is in the open, use configuration.

[0055] In a feature of this aspect of the invention, the two sub-platforms are disposed with front faces thereof adjacent one another when the baby carrier is in the closed, folded configuration.

[0056] In a feature of this aspect of the invention, the hinged platform includes a hinge mechanism that prevents the hinged platform when the baby carrier is in the open, use configuration from folding together into the closed, folded configuration unless the hinge mechanism is actuated.

[0057] In a feature of this aspect of the invention, the hinge mechanism includes a latch that prevents inadvertent folding of the carrier.

[0058] In a feature of this aspect of the invention, the hinge assembly includes hinge plates that prevent inadvertent folding of the carrier.

[0059] In a feature of this aspect of the invention, the hinged platform includes a hinge mechanism that prevents the hinged platform when the baby carrier is in the open, use configuration from over extending.

[0060] In addition to the aforementioned aspects and features of the present invention, it should be noted that the present invention further encompasses the various possible combinations and subcombinations of such aspects and features.

BRIEF DESCRIPTION OF THE DRAWINGS

[0061] One or more preferred embodiments of the present invention now will be described in detail with reference to the accompanying drawings, wherein the same elements are referred to with the same reference numerals, and wherein, [0062] FIG. 1 is a perspective view of a baby care assembly 10 in accordance with one or more aspects of the present invention;

[0063] FIG. 2 is a back elevational view of the baby care assembly 10 of FIG. 1;

[0064] FIG. 3 is a top plan view of the baby care assembly 10 of FIG. 1;

[0065] FIG. 4 is a bottom plan view of the baby care assembly 10 of FIG. 1;

[0066] FIG. 5 is a side elevational view of the baby care assembly 10 of FIG. 1 showing a baby carrier 100 of the assembly 10 stored in a baby bag 12;

[0067] FIG. 6 is a side elevational view of the baby care assembly 10 with the baby carrier 100 in the closed, folded configuration 18 removed from and sitting beside the baby bag 12;

[0068] FIG. 7 is a perspective view of the baby carrier 100 of the assembly 10 in the open, use configuration 16 with the canopy in a relaxed position;

[0069] FIG. 8 is a perspective view of the baby carrier 100 of the assembly 10 in the open, use configuration 16 with the canopy in an intermediate position;

[0070] FIG. 9 is a perspective view of the baby carrier 100 of the assembly 10 in the open, use configuration 16 with the canopy in a covering position;

[0071] FIG. 10 is a perspective view of a subassembly of the baby carrier 100;

[0072] FIG. 11 is an exploded perspective view of a subassembly of the baby carrier 100;

[0073] FIG. 12A is a perspective view of a latch 180 of the baby carrier 100;

[0074] FIG. 12B is a front elevational view of the latch 180 of FIG. 12A;

[0075] FIGS. 13A and 13B are front and back views, respectively, of a ratchet insert 174 of the baby carrier 100; and

[0076] FIGS. 14A and 14B are front and back views, respectively, of an internal support carrier 170 of the baby carrier 100.

[0077] FIG. 15 is a perspective view of a baby bag 310 in accordance with one or more aspects of the present invention.

[0078] FIG. 16 is a front elevational view of the baby bag 310 of FIG. 15.

[0079] FIG. 17 is a back elevational view of the baby bag 310 of FIG. 15.

[0080] FIG. 18 is the left elevational view of the baby bag 310 of FIG. 15.

[0081] FIG. 19 is the right elevational view of the baby bag 310 of FIG. 15.

[0082] FIG. 20A is a top plan view of the baby bag 310 of FIG. 15.

[0083] FIG. 20B is a bottom plan view of the baby bag 310 of FIG. 15.

[0084] FIG. 21 is a perspective view of a bassinet 410 in accordance with one or more aspects of the present invention.

[0085] FIG. 22 is a left elevational view of the bassinet 410 of FIG. 21.

[0086] FIG. 23 is a right elevational view of the bassinet 410 of FIG. 21.

[0087] FIG. 24 is a top plan view of the bassinet 410 of FIG. 21.

[0088] FIG. 25 is a bottom plan view of the bassinet 410 of FIG. 21.

[0089] FIG. 26 is a front elevational view of the bassinet 410 of FIG. 21.

[0090] FIG. 27 is a back elevational view of the bassinet 410 of FIG. 21.

[0091] FIG. 28 is a perspective view of the bassinet 410 of FIG. 21 in a closed configuration.

[0092] FIG. 29 is a top plan view of the bassinet 410 of FIG. 28.

[0093] FIG. 30 is a bottom plan view of the bassinet 410 of FIG. 28.

[0094] FIG. 31 is a left elevational view of the bassinet 410 of FIG. 28.

[0095] FIG. 32 is a right elevational view of the bassinet 410 of FIG. 28.

[0096] FIG. 33 is a front elevational view of the bassinet 410 of FIG. 28.

[0097] FIG. 34 is a back elevational view of the bassinet 410 of FIG. 28.

[0098] FIG. 35 is a perspective view of a bassinet 510 in accordance with one or more aspects of the present invention in a closed configuration.

[0099] FIG. 36A is a left elevational view of the bassinet 510 of FIG. 35.

[0100] FIG. 36B is a right elevational view of the bassinet 510 of FIG. 35.

[0101] FIG. 37A is a bottom elevational view of the bassinet 510 of FIG. 35.

[0102] FIG. 37B is a top elevational view of the bassinet 510 of FIG. 35.

[0103] FIG. 38 is a front elevational view of the bassinet 510 of FIG. 35.

[0104] FIG. 39 is a back elevational view of the bassinet 510 of FIG. 35.

[0105] FIG. 40 is a perspective view of the bassinet 510 of FIG. 35 in an open configuration.

[0106] FIG. 41 is a left elevational view of the bassinet 510 of FIG. 40.

[0107] FIG. 42 is a right elevational view of the bassinet 510 of FIG. 40.

[0108] FIG. 43 is a front elevational view of the bassinet 510 of FIG. 40.

[0109] FIG. 44 is a back elevational view of the bassinet 510 of FIG. 40.

[0110] FIG. 45 is a top plan view of the bassinet 510 of FIG. 40.

[0111] FIG. 46 is a bottom plan view of the bassinet 510 of FIG. 40.

DETAILED DESCRIPTION

[0112] As a preliminary matter, it will readily be understood by one having ordinary skill in the relevant art (“Ordinary Artisan”) that the present invention has broad utility and application. Furthermore, any embodiment discussed and identified as being “preferred” is considered to be part of a best mode contemplated for carrying out the present invention. Other embodiments also may be discussed for additional illustrative purposes in providing a full and enabling disclosure of the present invention. Moreover, many embodiments, such as adaptations, variations, modifications, and equivalent arrangements, will be implicitly disclosed by the embodiments described herein and fall within the scope of the present invention.

[0113] Accordingly, while the present invention is described herein in detail in relation to one or more embodiments, it is to be understood that this disclosure is illustrative and exemplary of the present invention, and is made merely for the purposes of providing a full and enabling disclosure of the present invention. The detailed disclosure herein of one or more embodiments is not intended, nor is to be construed, to limit the scope of patent protection afforded the present invention, which scope is to be defined by the claims and the equivalents thereof. It is not intended that the scope of patent protection afforded the present invention be defined by reading into any claim a limitation found herein that does not explicitly appear in the claim itself.

[0114] Thus, for example, any sequence(s) and/or temporal order of steps of various processes or methods that are described herein are illustrative and not restrictive. Accordingly, it should be understood that, although steps of various processes or methods may be shown and described as being in a sequence or temporal order, the steps of any such processes or methods are not limited to being carried out in any particular sequence or order, absent an indication otherwise. Indeed, the steps in such processes or methods generally may be carried out in various different sequences and orders while still falling within the scope of the present invention. Accordingly, it is intended that the scope of patent protection afforded the present invention is to be defined by the appended claims rather than the description set forth herein.

[0115] Additionally, it is important to note that each term used herein refers to that which the Ordinary Artisan would understand such term to mean based on the contextual use of such term herein. To the extent that the meaning of a term used

herein—as understood by the Ordinary Artisan based on the contextual use of such term—differs in any way from any particular dictionary definition of such term, it is intended that the meaning of the term as understood by the Ordinary Artisan should prevail.

[0116] Furthermore, it is important to note that, as used herein, “a” and “an” each generally denotes “at least one,” but does not exclude a plurality unless the contextual use dictates otherwise. Thus, reference to “a picnic basket having an apple” describes “a picnic basket having at least one apple” as well as “a picnic basket having apples.” In contrast, reference to “a picnic basket having a single apple” describes “a picnic basket having only one apple.”

[0117] When used herein to join a list of items, “or” denotes “at least one of the items,” but does not exclude a plurality of items of the list. Thus, reference to “a picnic basket having cheese or crackers” describes “a picnic basket having cheese without crackers”, “a picnic basket having crackers without cheese”, and “a picnic basket having both cheese and crackers.” Finally, when used herein to join a list of items, “and” denotes “all of the items of the list.” Thus, reference to “a picnic basket having cheese and crackers” describes “a picnic basket having cheese, wherein the picnic basket further has crackers,” as well as describes “a picnic basket having crackers, wherein the picnic basket further has cheese.”

[0118] Referring now to the drawings, one or more preferred embodiments of the present invention are next described. The following description of one or more preferred embodiments is merely exemplary in nature and is in no way intended to limit the invention, its applications, or uses.

[0119] Turning now to the drawings, a preferred embodiment of a baby care assembly 10 is shown in various views in FIGS. 1-6. The baby care assembly 10 includes a baby bag 12 and a baby carrier 100, wherein the baby bag 12 and the baby carrier 100 are configured and dimensioned to enable the baby bag 12 to receive and retain the baby carrier 100 in a carrier receiving area 14 (perhaps best seen in FIGS. 5 and 6) when the baby carrier 100 is not in use. The baby carrier 100 may be positioned in an open, use configuration 16 (perhaps best seen in FIG. 7), wherein a baby may be placed in the carrier 100, and a closed, folded configuration 18 (perhaps best seen in FIG. 6), wherein the carrier 100 is folded compactly and may be stored in the baby bag 12.

[0120] The baby bag 12 includes a front section 20 and a back section 22 with the baby carrier receiving area 14 disposed intermediate the front and back sections 20,22. The front section 20 and back section 22 are connected by a flap 24 that is fixedly attached to the back section 22 of the baby bag 12 (best seen in FIG. 2) at one end and that extends over a top 34 of the baby bag 12 and terminates near a bottom 36 of the front section 20 at the other end. A front fastener 30 releasably attaches the flap 24 to the front section 20 of the baby bag 12. In the exemplary embodiment, the fastener 30 is a clasp, however, the Ordinary Artisan will understand that any suitable fastener may be used. The flap 24 includes a zippered flap pocket 26 that is dimensioned to hold various, relatively small items. It will be understood that any conventional sealing mechanism may be used to seal the flap pocket 26, including, but not limited to a snap, a button, a velcro closure, and the like.

[0121] The sections 20,22 are also further connected by a receiving area closure panel 38. The receiving area closure panel 38 is fixedly attached to the baby bag 12 near the bottom 36 of the front section 20 and extends to be releasably

attached near a bottom of the back section 22. When the closure panel 38 is engaged, it encloses a bottom of the receiving area 14 and ensures that the baby carrier 100 is securely maintained in the receiving area 14 when it is placed therein. In a preferred embodiment, the receiving area closure panel 38 includes a velcro closure for releasably attaching the receiving area closure panel 38 to the back section 22 of the baby bag 12. However, as the Ordinary Artisan will understand, other releasable closure mechanisms may be utilized, including for example, snaps, buttons and the like. The closure panel 38 may be detached from the back section 22 to enable insertion or removal of the baby carrier 100 in the receiving area 14.

[0122] The front and back sections 20,22 are also connected by a pair of connection panels 52 near the top 34 of the baby bag 12. The connection panels 52 aid in holding the baby carrier 100 in the carrier receiving area 14. More particularly, each of the connection panels 52 includes an elastic element (not shown) disposed on an interior face thereof (not shown) to aid in holding the baby carrier 100 in the carrier receiving area 14. In addition, each of the connection panels 52 includes an eyelet opening 54 for attachment of a detachable shoulder strap 56 (best seen in FIGS. 1 and 4).

[0123] The front section 20 of the bag 12 includes a pair of front angled pockets 28, which are partially disposed beneath the flap 24 and the front fastener 30. The angled pockets 28 are ideal for storing baby bottles or other items that may need to be readily accessible when the baby care assembly 10 is being used.

[0124] The front section 20 and back section 22 each further includes a large pocket 48,50, respectively, for storage of relatively large items. The pockets 48,50 are arranged and dimensioned to be as large as the bag 12 will allow, i.e., the pockets 48,50 are essentially as wide as the bag 12 and are essentially as tall as the bag 12. While the exemplary embodiment shows the pockets 48,50 being secured by zipper closures, it will be understood that any conventional releasable closure mechanism may be used to secure the pockets 48,50. It is contemplated that the pockets 48,50 may be sized differently and may include interior sub-pockets (not shown) within the larger pockets 48,50 for items such as a cellular phone, a pacifier, and other items used by a baby and/or by a caregiver. In the exemplary embodiment, the pockets 48,50 are lined with a water-repellent or resistant fabric, such as nylon, however, it is contemplated that the pockets 48,50 may also contain an insulated lining for storage of bottles or other items that would benefit from being stored in an insulated container.

[0125] The bag 12 also includes a pair of grasping handles 46 disposed near a top of the front section 20 and back section 22. In the exemplary embodiment, the grasping handles 46 are fixedly attached to the baby bag 12, however, the Ordinary Artisan will understand that detachable handles are also within the scope of the present invention.

[0126] As shown in FIG. 5, the carrier receiving area 14 is dimensioned to fit the baby carrier 100 in the folded configuration 18 when it is placed therein. Advantageously, the storage capacity of the bag 12 is not adversely effected by placing the carrier 100 in the receiving area 14 because the various pockets 26,28,48,50 of the bag 12 are not compromised by the presence of the carrier 100. When the baby carrier 100 is placed in the receiving area 14, the receiving area closure panel 38 may be engaged to ensure that the baby carrier 100 is held securely within the receiving area 14.

[0127] Turning to the baby carrier 100 and with particular reference FIGS. 6 through 9, the baby carrier 100 includes an exterior cover 104, which is preferably made of the same material as the baby bag 12, a zipper closure 106 at a periphery 144 thereof to secure the baby carrier 100 in the closed, folded configuration, and an actuation button 108 at a termination point of the zipper closure 106. The actuation button 108 and its operation will be explained in greater detail below. The baby carrier 100 is shown in the closed, folded configuration in FIG. 6 and is shown in the open, use configuration in FIGS. 7 through 9.

[0128] The carrier 100 includes an interior 110, a base 112, opposed sides 114, and opposed ends 116. In the exemplary embodiment, the ends 116 of the carrier 100 are rounded or arched, however, the Ordinary Artisan will understand that ends 116 having a different shape are within the scope of the present invention. The sides 114 include a central hinging portion 118 whereat the carrier 100 hinges open and closed.

[0129] The carrier 100 also includes a removable base pad 120 for placement on the base 112 of the baby carrier 100. The base pad 120 covers substantially the entire base 112 and provides cushioning for a baby that has been placed in the carrier 100. In a preferred embodiment, the base pad 120 includes a cushioning insert (not shown) that is covered with a removable, machine-washable cover that may be easily cleaned. Alternatively, the cover may be non-removable, however, in such embodiment, it is contemplated that the base pad 120 as a whole would be machine washable for easy cleaning thereof.

[0130] The carrier 100 further includes a peripheral wall 122 that extends upwardly away from the base 112 when the carrier 100 is in the open, use configuration. The peripheral wall 122 includes side wall portions 124 and end wall portions 126. The peripheral wall 122 extends inwardly toward the interior 110 of the carrier 100 at an acute angle relative to the surface on which the carrier 100 is placed, i.e., the peripheral wall 122 is not orthogonal with respect to the surface on which the carrier 100 is placed. In addition, the peripheral wall 122 is comprised of a collapsible fabric material. The angle of the peripheral wall 122 and the material of the peripheral wall 122 facilitate easily collapsing the wall 122 into the interior 110 of the carrier 100 when the carrier 100 is folded into the closed, folded configuration. In the exemplary embodiment, the peripheral wall 122 is higher at the ends 116 of the carrier 100 than it is at the sides 114 of the carrier 100. In addition, the fabric of the peripheral wall 122 near the hinging portion 118 of the sides 114 is different than the fabric of the remainder of the peripheral wall 122, i.e., the hinging portion fabric is more pliable than the fabric of the remainder of the peripheral wall 122 to enable this region of the wall 122 to fold more easily since it is located at the hinging point of the carrier 100. The carrier 100 includes grasping handles 130 centrally located at the sides 114 thereof. More particularly, the grasping handles 130 are attached at edges of the hinging portion 118 of the sides 114.

[0131] In a feature of the carrier 100, the carrier 100 includes a canopy 132 for shading or protecting a baby lying in the carrier 100 from the elements. The canopy 132 includes a flexible internal support strip 134 (perhaps best shown in FIG. 10) disposed at a leading edge of the canopy 132 for providing a support structure for the canopy 132. The internal support strip 134 is removably attached to the carrier 100, more particularly to an internal support carrier 170 of the baby carrier 100. The canopy 132 may be positioned between

a relaxed position 136, wherein the canopy 132 is folded back against the peripheral wall 122 of the carrier 100, and a covering position 138, wherein the internal support strip 134 of the canopy 132 is essentially adjacent the peripheral wall 122 at the opposite end of the carrier 100. In this position, the canopy 132 is extended to cover substantially the entire interior 110 of the carrier 100 in the open, use configuration. The canopy 132 may be placed at intermediate positions between the relaxed position 136 and the covering position 138. The carrier 100 includes a hinge mechanism 140 (perhaps best shown in FIG. 11) that enables intermediate positioning. The hinge mechanism 140 includes a ratcheting mechanism 142 (perhaps best shown in FIG. 11) that enables the internal support strip 134 to be positioned at various positions intermediate the relaxed and covering positions 136,138 with the intermediate positions being at 15° increments relative to one another.

[0132] In addition, because the support strip 134 is removable from the carrier 100, the canopy 132 may be detached, rotated, and inserted back into the carrier 100 so that the canopy 132 can be used to partially cover the opposite end 116 of the carrier 100. This detachability feature is desirable for a user wishing to cover a portion of the interior 110 of the carrier 100 rather than the whole of the interior 110 of the carrier 100. Further, because the support strip 134 is detachable from the carrier 100, lifting of the carrier 100 by the canopy 132, as if the canopy 132 were a handle, is prevented. Rather, if a user tries to lift the carrier 100 using the canopy 132, the canopy 132 will simply detach from the carrier 100. Such lifting by the canopy 132 would be unbalanced and unsafe for a baby lying in the carrier 100. This safety feature ensures that the balanced grasping handles 130 of the carrier 100 are used to lift the carrier 100 when it is in the open, use configuration 16.

[0133] The zipper closure 106 of the carrier 100 is attached to the exterior cover 104 and begins near the actuation button 108 on one side of the carrier 100 and terminates near the actuation button 108 on the other side of the carrier 100 such that when the carrier 100 is folded and the zipper 106 engaged, the interior 110 of the carrier 100 is substantially enclosed. As such, when the carrier 100 is in the closed, folded configuration, the base pad 120, the peripheral wall 122, the canopy 132, and any other interior components of the carrier 100 are enclosed within the interior 110 of the carrier 100 by the zipper 106 and the cover 104. When the carrier 100 is in the folded configuration 18, only the exterior cover 104 and the zipper 106 are visible. While a zipper closure 106 is shown and described, the Ordinary Artisan will understand that any closure mechanism that enables substantial enclosure of the interior 110 of the carrier 100 may be used.

[0134] FIG. 10 shows the internal structure of the baby carrier 100. The carrier 100 includes a hinged platform 146 having two sub-platforms 148 that are connected to one another by the hinge mechanism 140. Each sub-platform 148 includes a planar front face 150 and back face with a peripheral rim 154. The rim 154 has a linear portion 156 and a rounded portion 158, with the linear portion 156 corresponding to the hinging portion 118 of the carrier 100 and the rounded portion 158 corresponding to the rounded ends 116 of the carrier 100. The linear rim portions 156 of the sub-platforms 148 abut one another when the platform 146 is assembled and in the open, use configuration 16. In addition, in the open, use configuration 16, the two sub-platforms 148 are disposed in the same horizontal plane such that the front

faces 150 of the sub-platforms 148 are spaced approximately 180° from one another. When the carrier 100 is in the closed, folded configuration 18, the two sub-platforms 148 are disposed with the front faces 150 thereof abutting one another. Each sub-platform 148 further includes a pair of hinge plates 160, best seen in FIG. 11, disposed at the peripheral rim 154 thereof at the intersections of the linear rim portion 156 and the rounded rim portion 158, with one plate 160 of the pair being at one end of the linear rim portion 156 and the other plate 160 of the pair being at the other end of the linear rim portion 156. When the sub-platforms 148 are moved between the open and closed configurations 16,18, the hinge plates 160 rotate or hinge along a shared axis.

[0135] Referring more specifically to the hinge mechanism 140 of the baby carrier 100, FIG. 11 provides an internal view of the hinge mechanism 140. While only one hinge mechanism 140 is shown and described herein, it will be understood that the hinge mechanisms 140 are identical and that the hinge mechanism 140 on the other side of the carrier 100 works in the same manner. The components of the hinge mechanism 140 will be named starting from the most exterior and going to the most interior, as shown in FIG. 11. Then the interaction and operation of the components of the hinge mechanism 140 will be described. The components include a cap 162, which is the part of the actuation button 108 seen by a user. The next components include a rivet 182, a button washer 164, a spring 166, a sleeve 168, and a carrier 170, which is dimensioned to accept and releasably retain the internal support strip 134 of the canopy 132. The next component is a retaining ring 172, then a ratchet insert 174, then a spacer 176, and then the hinge plates 160 of the carrier sub-platforms 148. The next component is a bushing 178, and then a latch 180.

[0136] When assembled, the rivet 182 extends through central openings of all of the components except the cap 162. The rivet 182 provides a central anchoring point for the components of the hinge mechanism 140 and provides a central axis 216 for the same. With particular reference to the latch 180, which is shown in FIGS. 12A and 12B, the latch 180 is a generally circular plate with a central opening for receipt there through of the rivet 182 and includes a pair of orthogonal projections 184 disposed in opposing facing relation to one another. As will be described in greater detail below, the orthogonal projections 184 interact with notched openings 190,192 of the hinge plates 160 to operably connect the hinge mechanism 140 with the carrier sub-platforms 148. While the latch 180 is generally circular, a radius of a portion 186 of the latch 180 approaching one of the orthogonal projections 184 is longer than a radius of the remaining portion of the latch 180. The portion 186 of the latch 180 with the extended radius is a feature of the hinge mechanism 140 that enables the carrier 100 to lock into the open, use configuration 16.

[0137] Because the carrier 100 locks into the open, use configuration 16, the hinge mechanism 140 must be activated by a user in order to move the carrier 100 from the open, use configuration 16 to the closed, folded configuration 18. This safety feature ensures that the carrier 100 does not close accidentally. In contrast, the hinge mechanism 140 does not lock into the closed, folded configuration 18, and therefore, does not have to be activated by a user in order to move the carrier 100 from the closed, folded configuration 18 to the open, use configuration 16. That is, once the carrier 100 has been unzipped, a user simply pulls the two sub-platforms 148 of the carrier 100 away from one another, and the carrier 100 opens to the open, use configuration 16, whereat the hinge

mechanism 140 locks to retain the carrier 100 in the open, use configuration 16. While the latch 180 of the present embodiment enables locking of the carrier 100 in the open, use configuration 16 only, it is contemplated that alternative embodiments may include a latch 180 that enables locking of the carrier 100 in both the open and closed configurations 16,18.

[0138] Returning to FIG. 11, the sleeve 168 abuts the latch 180 at one end thereof and the button washer 164 at the other end thereof. The sleeve 168 fits in concentric relation within the bushing 178, and both the sleeve 168 and the bushing 178 fit in concentric relation on the rivet 182, with the order of the components from inside to outside being rivet 182, sleeve 168, bushing 178. The bushing 178 and sleeve 168 fit through central openings 188 in the hinge plates 160 of the sub-platforms 148 with the spacer disk 176 being interposed between the two hinge plates 160.

[0139] The hinge plates 160 are generally circular with a central opening 188 for receipt there through of the rivet 182, bushing 178, and sleeve 168. Each of the hinge plates 160 includes a pair of notched openings 190,192 disposed opposite one another in the hinge plate 160. A first notched opening 190 of the pair is adjacent a perimeter 194 of the hinge plate 160 such that the notched opening 190 is bounded on three sides and is open on a fourth side. A second notched opening 192 of the pair is disposed intermediate the perimeter 194 of the hinge plate 160 and the central opening 188 of the hinge plate 160 and therefore is closed or bound on all four sides. In addition, each of the hinge plates 160 includes a pair of round openings 196 disposed opposite one another in the hinge plate 160. The pair of round openings 196 are symmetrically arranged in the hinge plate 160. In addition, the pair of notched openings 190,192 and the pair of round openings 196 are arranged in orthogonal relation to one another in the hinge plate 160.

[0140] When the carrier 100 is in the open, use configuration 16, the pairs of notched openings 190,192 of the hinge plates 160 are aligned with one another, more particularly, the first notched opening 190 of one of the hinge plates 160 is aligned with the first notched opening 190 of the other hinge plate 160, and the second notched opening 192 of one hinge plate 160 is aligned with the second notched opening 192 of the other hinge plate 160. In the open, use configuration 16, the orthogonal projections 184 of the latch 180 fit through the notched openings 190,192 of the hinge plates 160, more particularly the orthogonal projection 184 associated with the extended radius portion 186 of the latch 180 fits through the first notched openings 190 of the hinge plates 160, and the orthogonal projection 184 associated with the remaining portion of the latch 180 fits into the second notched openings 192 of the hinge plates 160. The insertion of the orthogonal projections 184 into the notched openings 190,192 of the hinge plates 160 locks the carrier 100 into the open, use configuration 16. When the carrier 100 is in the closed, folded configuration 18, the hinge plates 160 are rotated such that the notched openings 190,192 of the hinge plates 160 do not align because the first notched opening 190 of one hinge plate 160 is disposed opposite the first notched opening 190 of the other hinge plate 160 and the second notched opening 192 of one hinge plate 160 is disposed opposite the second notched opening 192 of the other hinge plate 160. Thus the orthogonal projections 184 of the latch 180 do not fit through the aligned notched openings 190,192 of the hinge plates 160 as they do in the open, use configuration 16.

[0141] Based on the foregoing explanation, it will be understood how the latch 180 locks the carrier 100 into the open, use configuration 16 but does not lock the carrier 100 into the closed, folded configuration 18. Locking in the open, use configuration 16 is a safety feature that protects the carrier 100 from being inadvertently closed or inadvertently overextended, i.e., the carrier platform 146 will not be overextended such that the sub-platform front faces 150 are more than 180° from one another. The concern regarding overextension is more prevalent when the baby carrier 100 is being lifted or carried such as when a child is being moved while in the baby carrier 100.

[0142] Exterior the hinge plates 160, the ratchet insert 174 is held on the bushing 178 by the retaining ring 172. With particular reference to the ratchet insert 174 and as shown in FIGS. 13A and 13B, the ratchet insert 174 is generally rectangular in shape and includes an exterior face 198 and an interior face 200. The ratchet insert 174 includes teeth 202 extending from the exterior face 198 thereof that enable incremental positioning of the internal support strip 134 of the canopy 132. The ratchet insert 174 also includes a pair of circular projections 204 that extend from the interior face 200 thereof. The pair of circular projections 204 are aligned with and fit within the pair of round openings 196 of the hinge plates 160 when the carrier 100 is in the open, use configuration 16.

[0143] With particular reference to the internal support carrier 170 and as shown in FIGS. 14A and 14B, the internal support carrier 170 is generally circular and includes an interior face 206 and an exterior face 208 that is recessed into a peripheral wall 210 of the internal support carrier 170. The internal support carrier 170 fits on the sleeve 168 external the ratchet retaining ring 172 and interacts with the ratchet insert 174 to enable variable positioning of the internal support strip 134. More specifically, the interior face 206 of the internal support carrier 170 includes radially disposed teeth 212 that cover substantially all of the interior face 206 and that interact with the teeth 202 of the ratchet insert 174. Accordingly, the ratchet insert 174 and the internal support carrier 170 provide a ratchet mechanism 142 for the carrier 100.

[0144] In the present embodiment, the teeth 202,212 are arranged to enable ratcheting in 15° increments, however, the Ordinary Artisan will understand that the teeth 202,212 can be arranged to provide positioning at various angle increments. To change the position of the canopy 132, a user simply applies a minimal force to move the internal support strip 134 toward or away from the end 116 of the carrier 100 at which the canopy 132 is inserted. The teeth 202,212 of ratchet mechanism 142 resist movement but allow the support strip 134 to be moved once a minimal force is exerted. The ratchet mechanism 142 is intended to prohibit the canopy 132 from being moved between positions inadvertently, however, the application of minimal force will enable movement of the canopy 132 between variable positions.

[0145] Returning to FIG. 11, the spring 166 is concentrically arranged on the sleeve 168, and the button washer 164 abuts the sleeve 168 and the spring 166. The cap 162 fits on the outer diameter of the button washer 164, and the spring 166, the button washer 164 and the cap 162 create the actuation button 108 of the carrier 100. The cap 162 provides an aesthetically pleasing cover to the hinge mechanism 140 and hides the spring 166 and the button washer 164 from a user. The spring 166, the button washer 164, and the cap 162 all fit into the recessed area of the internal support carrier 170.

[0146] In order to activate the latch 180 to move the carrier 100 between the open, use configuration 16 and the closed, folded configuration 18, a user presses the cap 162 and moves the carrier 100 in the desired direction. In the present embodiment, the latch 180 is activated in order to close the carrier 100. However, it is contemplated that in an alternative embodiment the hinge mechanism 140, and more specifically the latch 180, may need to be activated to open the carrier 100.

[0147] When the latch 180 is in the open, use configuration 16 and the cap 162 is pressed, the cap 162 exerts a force on the button washer 164 and the spring 166, which is transferred to the latch 180 by the sleeve 168. The latch 180 is moved inwardly, thereby disengaging the orthogonal projections 184 from the notched openings 190, 192 of the exterior hinge plate 160. Once the orthogonal projections 184 are disengaged from the exterior hinge plate 160, the pair of hinge plates 160 are free to rotate relative to one another, which enables the sub-platforms 148 of the carrier 100 to be moved toward one another until they are abutting one another in the closed, folded configuration 18.

[0148] FIG. 15 is a perspective views of a baby bag 310 in accordance with another embodiment of the present invention. Various additional views of the baby bag 310 are further illustrated in FIGS. 16-20B.

[0149] FIG. 21 is a perspective view of a bassinet 410 in accordance with another embodiment of the present invention. The bassinet 410 is illustrated in FIG. 21 in an open configuration. Various additional views of the bassinet 410 are further illustrated in FIGS. 22-27.

[0150] FIG. 28 is a perspective view of the bassinet 410 in a closed configuration. Various additional views of the bassinet 410 in this closed configuration are further illustrated in FIGS. 29-34.

[0151] FIG. 35 is a perspective view of a bassinet 510 in accordance with another embodiment of the present invention. The bassinet 510 is illustrated in FIG. 35 in a closed configuration. Various additional views of the bassinet 510 in this closed configuration are further illustrated in FIGS. 36A-39.

[0152] FIG. 40 is a perspective view of the bassinet 510 in an open configuration. Various additional views of the bassinet 510 are further illustrated in FIGS. 41-46.

[0153] Based on the foregoing description, it will be readily understood by those persons skilled in the art that the present invention is susceptible of broad utility and application. Many embodiments and adaptations of the present invention other than those specifically described herein, as well as many variations, modifications, and equivalent arrangements, will be apparent from or reasonably suggested by the present invention and the foregoing descriptions thereof, without departing from the substance or scope of the present invention. Accordingly, while the present invention has been described herein in detail in relation to one or more preferred embodiments, it is to be understood that this disclosure is only illustrative and exemplary of the present invention and is made merely for the purpose of providing a full and enabling disclosure of the invention. The foregoing disclosure is not intended to be construed to limit the present invention or otherwise exclude any such other embodiments, adaptations, variations, modifications or equivalent arrangements, the present invention being limited only by the claims appended hereto and the equivalents thereof.

1-53. (canceled)

54. A baby care assembly, comprising:

- (a) a baby carrier positionable between an open, use configuration and a closed, folded configuration, the baby carrier including
 - (i) a base,
 - (ii) end and side walls that extend upwardly away from the base when the baby carrier is in the open, use configuration and that fold into the baby carrier when the baby carrier is in the closed, folded configuration, and
 - (iii) a canopy having a leading edge supported by an internal support strip; and
- (b) a baby bag including a carrier receiving area configured to receive and retain the baby carrier when the baby carrier is in the closed, folded configuration;
- (c) wherein the baby carrier is configured such that when in the open, use configuration, a baby may be placed in the baby carrier.

55. The baby care assembly of claim 54, wherein, when the baby carrier is in the open, use configuration, the canopy is positionable between a relaxed position, wherein the canopy, including the internal support strip, is folded against a peripheral wall of the baby carrier at a first end thereof, and a covering position, wherein the canopy is stretched across an interior of the baby carrier such that the internal support strip is abutting the peripheral wall of the baby carrier on an end opposite the first end.

56. The baby care assembly of claim 55, wherein the canopy is positionable at intermediate positions between the relaxed position and the covering position.

57. The baby care assembly of claim 56, wherein intermediate positioning is enabled by a ratchet mechanism.

58. The baby care assembly of claim 54, wherein the end and side walls are configured such that, when the baby carrier is disposed on a flat surface in the open, use configuration, the end and side walls extend inwardly towards an interior of the baby carrier at an acute angle relative to the surface.

59. The baby care assembly of claim 54, wherein the baby bag includes a front section and a back section, the carrier receiving area is defined between the front and back sections of the baby bag, and a receiving area closure panel releasably connects the front section of the baby bag to the back section of the baby bag when it is engaged.

60. The baby care assembly of claim 54, wherein the canopy is releasably connected to the baby carrier.

61. The baby care assembly of claim 54, wherein the baby carrier includes a pair of centrally disposed, grasping handles, one on each side of the baby carrier.

62. The baby care assembly of claim 54, wherein the baby carrier includes a removable base pad.

63. The baby care assembly of claim 54, wherein the baby carrier includes a closure mechanism at a periphery thereof for securing the baby carrier in the closed, folded configuration.

64. A baby care assembly, comprising:

- (a) a baby carrier including a hinged platform, the hinged platform including first and second sub-platforms hingedly connected to one another, each of the first and second sub-platforms including
 - (i) a planar front face, and
 - (ii) a perimeter including a linear portion; and

- (b) a baby bag including a carrier receiving area configured to receive and retain the baby carrier when the baby carrier is in a closed, folded configuration;
- (c) wherein the baby carrier is positionable between two configurations,
 - (i) an open, use configuration, wherein a baby may be placed in the baby carrier, and
 - (ii) the closed, folded configuration; and
- (d) wherein the linear portion of the perimeter of the first sub-platform is arranged in abutting relation to the linear portion of the perimeter of the second sub-platform.

65. The baby care assembly of claim **64**, wherein the baby bag includes a front section and a back section, the carrier receiving area is defined between the front and back sections of the baby bag, and a receiving area closure panel releasably connects the front section of the baby bag to the back section of the baby bag when it is engaged.

66. The baby care assembly of claim **64**, wherein the first and second sub-platforms are disposed in the same horizontal plane such that an approximately 180° angle is formed between the front face of the first sub-platform and the front face of the second sub-platform when the baby carrier is in the open, use configuration.

67. The baby care assembly of claim **64**, wherein the hinged platform includes a hinge mechanism that prevents the hinged platform, when the baby carrier is in the open, use configuration, from folding together into the closed, folded configuration unless the hinge mechanism is actuated.

68. A baby carrier positionable between an open, use configuration and a closed, folded configuration, the baby carrier comprising

- (a) a base including first and second sub-platforms hingedly connected to one another, each of the first and second sub-platforms including

- (i) a planar front face, and
- (ii) a perimeter including a linear portion;
- (b) end and side walls that extend upwardly away from the base when the baby carrier is in the open, use configuration and that fold into the baby carrier when the baby carrier is in the closed, folded configuration; and
- (c) a canopy having a leading edge supported by an internal support strip;
- (d) wherein the linear portion of the perimeter of the first sub-platform is arranged in abutting relation to the linear portion of the perimeter of the second sub-platform; and
- (e) wherein the baby carrier is configured such that when in the open, use configuration, a baby may be placed in the baby carrier.

69. The baby carrier of claim **68**, wherein, when the baby carrier is disposed on a flat surface in the open, use configuration, the end and side walls extend inwardly toward an interior of the baby carrier at an acute angle relative to the surface.

70. The baby carrier of claim **68**, wherein the first and second sub-platforms are disposed in the same horizontal plane such that an approximately 180° angle is formed between the front face of the first sub-platform and the front face of the second sub-platform when the baby carrier is in the open, use configuration.

71. The baby carrier of claim **68**, wherein the hinged platform includes a hinge mechanism that prevents the hinged platform, when the baby carrier is in the open, use configuration, from folding together into the closed, folded configuration unless the hinge mechanism is actuated.

72. The baby carrier of claim **68**, wherein the baby carrier includes a closure mechanism at a periphery thereof for securing the baby carrier in the closed, folded configuration.

73. The baby carrier of claim **68**, wherein the canopy is releasably connected to the baby carrier.

* * * * *