



US00RE49092E

(19) **United States**
(12) **Reissued Patent**
Neiley et al.

(10) **Patent Number:** **US RE49,092 E**
(45) **Date of Reissued Patent:** **Jun. 7, 2022**

- (54) **LACE FIXATION ASSEMBLY AND SYSTEM**
- (71) Applicant: **Boa Technology Inc.**, Denver, CO (US)
- (72) Inventors: **Roger T. Neiley**, Laguna Beach, CA (US); **Thomas Trudel**, Denver, CO (US); **Kristopher Lovett**, Denver, CO (US)
- (73) Assignee: **Boa Technology Inc.**, Denver, CO (US)
- (21) Appl. No.: **16/826,105**
- (22) Filed: **Mar. 20, 2020**

Related U.S. Patent Documents

- Reissue of:
- (64) Patent No.: **9,439,477**
 - Issued: **Sep. 13, 2016**
 - Appl. No.: **14/166,799**
 - Filed: **Jan. 28, 2014**
- U.S. Applications:
- (62) Division of application No. 16/130,943, filed on Sep. 13, 2018, now Pat. No. Re. 48,215, which is an application for the reissue of Pat. No. 9,439,477.
(Continued)
 - (51) **Int. Cl.**
A43C 1/06 (2006.01)
A43C 7/00 (2006.01)
 - (52) **U.S. Cl.**
CPC *A43C 7/00* (2013.01); *Y10T 24/2183* (2015.01); *Y10T 24/3703* (2015.01); *Y10T 24/3724* (2015.01)
 - (58) **Field of Classification Search**
CPC *Y10T 24/2183*; *Y10T 24/3703*; *Y10T 24/3724*
(Continued)

(56) **References Cited**

U.S. PATENT DOCUMENTS

59,332 A	10/1866	White et al.
80,834 A	8/1868	Prussia

(Continued)

FOREIGN PATENT DOCUMENTS

AT	127075	2/1932
AT	244804	1/1966

(Continued)

OTHER PUBLICATIONS

International Search Report and Written Opinion mailed May 19, 2014 for International Patent Application No. PCT/US2014/013458 filed Jan. 28, 2014, all pages.

(Continued)

Primary Examiner — Beverly M Flanagan
(74) *Attorney, Agent, or Firm* — Kilpatrick Townsend & Stockton, LLP

(57) **ABSTRACT**

A lace closure system may include a low friction guide that defines the turning radius and direction of a lace which, though tension, pulls two or more panels toward each other. The lace closure system may include a fixator that defines a slot into which the lace is led, containing multiple engagement surfaces that, when the lace is wrapped into the slot, serve to engage the lace preventing unwanted loosening. The lace closure system may include a ring onto which the lace is attached, to assist in applying manual tension to the lace. The ring may be shaped and sized to removably attach to an outer perimeter of the fixator after excess lace has been wrapped into the slot.

13 Claims, 32 Drawing Sheets

2400

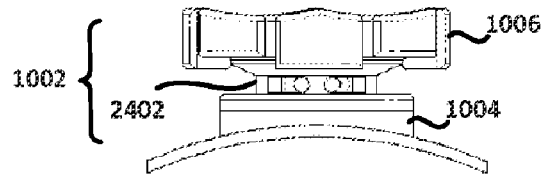

Related U.S. Application Data

- (60) Provisional application No. 61/757,692, filed on Jan. 28, 2013.
- (58) **Field of Classification Search**
USPC 24/713.2, 714.8, 712.9, 68 SK, 69 SK
See application file for complete search history.

References Cited

U.S. PATENT DOCUMENTS

			4,408,403 A	10/1983	Martin
			4,417,703 A	11/1983	Weinhold
			4,433,456 A	2/1984	Baggio
			4,463,761 A	8/1984	Polis et al.
			4,480,395 A	11/1984	Schoch
			4,507,878 A	4/1985	Semouha
			4,516,576 A	5/1985	Kirchner
			4,551,932 A	11/1985	Schoch
			4,555,830 A	12/1985	Petrini et al.
			4,574,500 A	3/1986	Aldinio et al.
			4,616,432 A	10/1986	Bunch et al.
			4,616,524 A	10/1986	Bidoia
			4,619,057 A	10/1986	Sartor et al.
			4,620,378 A	11/1986	Sartor
			4,631,839 A	12/1986	Bonetti et al.
			4,631,840 A	12/1986	Gamm
			4,633,599 A	1/1987	Morell et al.
			4,644,938 A	2/1987	Yates et al.
			4,654,985 A	4/1987	Chalmers
			4,660,300 A	4/1987	Morell et al.
			4,660,302 A	4/1987	Arieh et al.
			4,680,878 A	7/1987	Pozzobon et al.
			4,719,670 A	1/1988	Kurt
			4,719,709 A	1/1988	Vaccari
			4,719,710 A	1/1988	Pozzobon
			4,722,477 A	2/1988	Floyd
			4,741,115 A	5/1988	Pozzobon
			4,748,726 A	6/1988	Schoch
			4,760,653 A	8/1988	Baggio
			4,780,969 A	11/1988	White, Jr.
			4,787,124 A	11/1988	Pozzobon et al.
			4,790,081 A	12/1988	Benoit et al.
			4,796,829 A	1/1989	Pozzobon et al.
			4,799,297 A	1/1989	Baggio et al.
			4,802,291 A	2/1989	Sartor
			4,811,503 A	3/1989	Iwama
			4,826,098 A	5/1989	Pozzobon et al.
			4,841,649 A	6/1989	Baggio et al.
			4,856,207 A	8/1989	Datson
			4,862,878 A	9/1989	Davison
			4,870,723 A	10/1989	Pozzobon et al.
			4,870,761 A	10/1989	Tracy
			4,884,760 A	12/1989	Baggio et al.
			4,901,938 A	2/1990	Cantley et al.
			4,924,605 A	5/1990	Spademan
			D308,282 S	6/1990	Bergman et al.
			4,937,953 A	7/1990	Walkhoff
			4,961,544 A	10/1990	Bidoia
			4,979,953 A	12/1990	Spence
			4,989,805 A	2/1991	Burke
			5,001,817 A	3/1991	De Bortoli et al.
			5,016,327 A	5/1991	Klausner
			5,042,177 A	8/1991	Schoch
			5,062,225 A	11/1991	Gorza
			5,065,480 A	11/1991	DeBortoli
			5,065,481 A	11/1991	Walkhoff
			5,108,216 A	4/1992	Geyer et al.
			5,117,567 A	6/1992	Berger
			5,152,038 A	10/1992	Schoch
			5,157,813 A	10/1992	Carroll
			5,158,428 A	10/1992	Gessner et al.
			5,177,882 A	1/1993	Berger
			5,181,331 A	1/1993	Berger
			5,184,378 A	2/1993	Batra
			D333,552 S	3/1993	Berger et al.
			5,205,055 A	4/1993	Harrell
			5,233,767 A	8/1993	Kramer
			5,249,377 A	10/1993	Walkhoff
			5,259,094 A	11/1993	Zepeda
			5,315,741 A	5/1994	Dubberke
			5,319,868 A	6/1994	Hallenbeck
			5,319,869 A	6/1994	McDonald et al.
			5,325,613 A	7/1994	Sussmann
			5,327,662 A	7/1994	Hallenbeck
			5,335,401 A	8/1994	Hanson
			5,341,583 A	8/1994	Hallenbeck
			5,345,697 A	9/1994	Quellais
			5,355,596 A	10/1994	Sussmann
			5,357,654 A	10/1994	Hsing-Chi

(56)

References Cited

U.S. PATENT DOCUMENTS

5,371,957	A	12/1994	Gaudio	6,286,233	B1	9/2001	Gaither	
5,381,609	A	1/1995	Hieblinger	6,289,558	B1	9/2001	Hammerslag	
5,392,535	A	2/1995	Van Noy et al.	6,311,633	B1	11/2001	Keire	
D357,576	S	4/1995	Steinweis	D456,130	S	4/2002	Towns	
5,425,161	A	6/1995	Schoch	6,370,743	B2	4/2002	Choe	
5,425,185	A	6/1995	Gansler	6,401,364	B1	6/2002	Burt	
5,430,960	A	7/1995	Richardson	6,416,074	B1	7/2002	Maravetz et al.	
5,433,648	A	7/1995	Frydman	6,467,195	B2	10/2002	Pierre et al.	
5,463,822	A	11/1995	Miller	6,477,793	B1	11/2002	Pruitt et al.	
5,477,593	A	12/1995	Leick	6,502,286	B1*	1/2003	Dubberke	A43C 7/00 24/712.1
D367,755	S	3/1996	Jones	6,543,159	B1	4/2003	Carpenter et al.	
D367,954	S	3/1996	Dion	6,568,103	B2	5/2003	Durocher	
5,502,902	A	4/1996	Sussmann	6,606,804	B2	8/2003	Kaneko et al.	
5,511,325	A	4/1996	Hieblinger	6,694,643	B1	2/2004	Hsu	
5,526,585	A	6/1996	Brown et al.	6,708,376	B1	3/2004	Landry	
5,535,531	A	7/1996	Karabed et al.	6,711,787	B2	3/2004	Jungkind et al.	
5,537,763	A	7/1996	Donnadieu et al.	6,735,829	B2	5/2004	Hsu	
5,557,864	A	9/1996	Marks	6,757,991	B2	7/2004	Sussmann	
5,566,474	A	10/1996	Leick et al.	6,775,928	B2	8/2004	Grande et al.	
D375,831	S	11/1996	Perry	6,792,702	B2	9/2004	Borsoi et al.	
5,596,820	A	1/1997	Edauw et al.	6,802,439	B2	10/2004	Azam et al.	
5,599,000	A	2/1997	Bennett	6,823,610	B1	11/2004	Ashley	
5,599,288	A	2/1997	Shirley et al.	6,871,812	B1	3/2005	Chang	
5,600,874	A	2/1997	Jungkind	6,877,256	B2	4/2005	Martin et al.	
5,606,778	A	3/1997	Jungkind	6,899,720	B1	5/2005	McMillan	
5,607,448	A	3/1997	Stahl et al.	6,922,917	B2	8/2005	Kerns et al.	
D379,113	S	5/1997	McDonald et al.	6,938,913	B2	9/2005	Elkington	
5,638,588	A	6/1997	Jungkind	6,945,543	B2	9/2005	De Bortoli et al.	
5,640,785	A	6/1997	Egelja	D510,183	S	10/2005	Tresser	
5,647,104	A	7/1997	James	6,976,972	B2	12/2005	Bradshaw	
5,651,198	A	7/1997	Sussmann	6,993,859	B2	2/2006	Martin et al.	
5,669,116	A	9/1997	Jungkind	D521,226	S	5/2006	Douglas et al.	
5,692,319	A	12/1997	Parker et al.	7,073,279	B2	7/2006	Min	
5,718,021	A	2/1998	Tatum	7,076,843	B2	7/2006	Sakabayashi	
5,718,065	A	2/1998	Locker	7,082,701	B2	8/2006	Dalgaard et al.	
5,720,084	A	2/1998	Chen	7,096,559	B2	8/2006	Johnson et al.	
5,732,483	A	3/1998	Cagliari	7,134,224	B2	11/2006	Elkington et al.	
5,732,648	A	3/1998	Aragon	7,266,911	B2	9/2007	Holzer et al.	
5,736,696	A	4/1998	Del Rosso	7,281,341	B2	10/2007	Reagan et al.	
5,737,854	A	4/1998	Sussmann	7,293,373	B2	11/2007	Reagan et al.	
5,755,044	A	5/1998	Veylupek	7,331,126	B2	2/2008	Johnson	
5,756,298	A	5/1998	Burczak	7,343,701	B2	3/2008	Pare et al.	
5,761,777	A	6/1998	Leick	7,367,522	B2	5/2008	Chen	
5,772,146	A	6/1998	Kawamoto et al.	7,386,947	B2	6/2008	Martin et al.	
5,784,809	A	7/1998	McDonald	7,392,602	B2	7/2008	Reagan et al.	
5,791,068	A	8/1998	Bernier et al.	7,401,423	B2	7/2008	Reagan et al.	
5,819,378	A	10/1998	Doyle	7,490,458	B2	2/2009	Ford	
5,833,640	A	11/1998	Vazquez, Jr. et al.	7,568,298	B2	8/2009	Kerns	
5,839,210	A	11/1998	Bernier et al.	7,582,102	B2	9/2009	Heinz et al.	
5,845,371	A	12/1998	Chen	7,584,528	B2	9/2009	Hu	
5,909,946	A	6/1999	Okajima	7,591,050	B2	9/2009	Hammerslag	
D413,197	S	8/1999	Faye	7,597,675	B2	10/2009	Ingimundarson et al.	
5,934,599	A	8/1999	Hammerslag	7,600,660	B2	10/2009	Kasper et al.	
5,937,542	A	8/1999	Bourdeau	7,617,573	B2	11/2009	Chen	
5,956,823	A	9/1999	Borel	7,624,517	B2	12/2009	Smith	
5,971,946	A	10/1999	Quinn et al.	7,648,404	B1	1/2010	Martin	
6,015,110	A	1/2000	Lai	7,650,705	B2	1/2010	Donnadieu et al.	
6,038,791	A	3/2000	Cornelius et al.	7,694,354	B2	4/2010	Philpott et al.	
6,052,921	A	4/2000	Oreck	7,752,774	B2	7/2010	Ussher	
6,070,886	A	6/2000	Cornelius et al.	7,757,412	B2	7/2010	Farys	
6,070,887	A	6/2000	Cornelius et al.	7,774,956	B2	8/2010	Dua et al.	
6,083,857	A	7/2000	Botgger et al.	D626,322	S	11/2010	Servettaz	
6,088,936	A	7/2000	Bahl	7,841,106	B2	11/2010	Farys	
6,102,412	A	8/2000	Staffaroni	7,871,334	B2	1/2011	Young et al.	
D430,724	S	9/2000	Matis et al.	7,877,845	B2	2/2011	Signori	
6,119,318	A	9/2000	Maurer	7,900,378	B1	3/2011	Busse	
6,119,372	A	9/2000	Okajima	7,908,769	B2	3/2011	Pellegrini	
6,128,835	A	10/2000	Ritter et al.	7,947,061	B1	5/2011	Reis	
6,128,836	A	10/2000	Barret	7,950,112	B2	5/2011	Hammerslag et al.	
6,148,489	A	11/2000	Dickie et al.	7,954,204	B2	6/2011	Hammerslag et al.	
6,202,953	B1	3/2001	Hammerslag	7,963,049	B2	6/2011	Messmer	
6,219,891	B1	4/2001	Maurer et al.	7,992,261	B2	8/2011	Hammerslag et al.	
6,240,657	B1	6/2001	Weber et al.	D646,790	S	10/2011	Castillo et al.	
6,256,798	B1	7/2001	Egolf et al.	8,056,150	B2	11/2011	Stokes et al.	
6,267,390	B1	7/2001	Maravetz et al.	8,074,379	B2	12/2011	Robinson, Jr. et al.	
				8,091,182	B2	1/2012	Hammerslag et al.	
				8,109,015	B2	2/2012	Signori	
				D663,850	S	7/2012	Joseph	

(56)	References Cited		2008/0066345	A1	3/2008	Hammerslag et al.	
	U.S. PATENT DOCUMENTS		2008/0066346	A1	3/2008	Hammerslag et al.	
	D663,851	7/2012 Joseph	2008/0068204	A1	3/2008	Carmen et al.	
	8,215,033	B2 7/2012 Carboy et al.	2008/0083135	A1	4/2008	Hammerslag et al.	
	8,231,074	B2 7/2012 Hu et al.	2008/0092279	A1	4/2008	Chiang	
	D665,088	S 8/2012 Joseph	2008/0172848	A1	7/2008	Chen	
	8,235,321	B2 8/2012 Chen	2008/0196224	A1	8/2008	Hu	
	8,245,371	B2 8/2012 Chen	2009/0019734	A1*	1/2009	Reagan	A43B 3/0031 36/115
	8,257,293	B2 9/2012 Ingimundarson et al.	2009/0071041	A1	3/2009	Hooper	
	8,266,827	B2 9/2012 Dojan et al.	2009/0090029	A1	4/2009	Kishino	
	8,277,401	B2 10/2012 Hammerslag et al.	2009/0172928	A1	7/2009	Messmer et al.	
	8,302,329	B2 11/2012 Hurd et al.	2009/0184189	A1	7/2009	Soderberg et al.	
	8,303,527	B2 11/2012 Joseph	2009/0272007	A1	11/2009	Beers et al.	
	8,308,098	B2 11/2012 Chen	2009/0277043	A1	11/2009	Graser et al.	
	8,353,087	B2 1/2013 Chen	2010/0064547	A1	3/2010	Kaplan	
	8,353,088	B2 1/2013 Ha	2010/0101061	A1	4/2010	Ha	
	D677,045	S 3/2013 Voskuil	2010/0139057	A1	6/2010	Soderberg et al.	
	D679,019	S 3/2013 Siddle et al.	2010/0154254	A1	6/2010	Fletcher	
	1,060,422	A1 4/2013 Bowdish	2010/0175163	A1	7/2010	Litke	
	1,062,511	A1 5/2013 Short	2010/0218349	A1*	9/2010	Whang	A43C 7/08 24/712.2
	8,434,200	B2 5/2013 Chen	2010/0251524	A1	10/2010	Chen	
	8,490,299	B2 7/2013 Dua et al.	2010/0299959	A1	12/2010	Hammerslag	
	8,516,662	B2 8/2013 Goodman et al.	2010/0319216	A1	12/2010	Grenzke et al.	
	8,578,632	B2 11/2013 Bell et al.	2011/0000173	A1	1/2011	Lander	
	1,083,775	A1 1/2014 Thomas	2011/0071647	A1	3/2011	Mahon	
	8,652,164	B1 2/2014 Aston	2011/0162236	A1	7/2011	Voskuil et al.	
	8,713,820	B2 5/2014 Kerns et al.	2011/0167543	A1	7/2011	Kovacevich et al.	
	1,090,438	A1 3/2015 Worth et al.	2011/0191992	A1	8/2011	Chen	
	8,984,719	B2 3/2015 Soderberg et al.	2011/0197362	A1	8/2011	Chella et al.	
	9,072,341	B2 7/2015 Jungkind	2011/0225843	A1	9/2011	Kerns et al.	
	D735,987	S 8/2015 Hsu	2011/0258876	A1	10/2011	Baker et al.	
	9,101,181	B2 8/2015 Soderberg et al.	2011/0266384	A1	11/2011	Goodman et al. ...	A43C 11/165 242/396.4
	9,125,455	B2 9/2015 Kerns et al.	2012/0000091	A1	1/2012	Cotterman et al.	
	9,138,030	B2 9/2015 Soderberg et al.	2012/0004587	A1	1/2012	Nickel et al.	
	2002/0050076	A1 5/2002 Borsoi et al.	2012/0005995	A1	1/2012	Emery	
	2002/0062579	A1 5/2002 Caeran	2012/0023717	A1	2/2012	Chen	
	2002/0095750	A1 7/2002 Hammerslag	2012/0101417	A1	4/2012	Joseph	
	2002/0129518	A1 9/2002 Borsoi et al.	2012/0102783	A1	5/2012	Swigart et al.	
	2002/0148142	A1 10/2002 Oorei et al.	2012/0138882	A1	6/2012	Moore et al.	
	2002/0166260	A1 11/2002 Borsoi	2012/0157902	A1	6/2012	Castillo et al.	
	2002/0178548	A1 12/2002 Freed	2012/0167290	A1	7/2012	Kovacevich et al.	
	2003/0024084	A1* 2/2003 Liu	2012/0174437	A1	7/2012	Heard	A43C 7/00 24/712.1
	2003/0079376	A1 5/2003 Oorei et al.	2012/0228419	A1	9/2012	Chen	
	2003/0144620	A1 7/2003 Sieller et al.	2012/0246974	A1	10/2012	Hammerslag et al.	
	2003/0150135	A1 8/2003 Liu	2012/0310273	A1	12/2012	Thorpe	
	2003/0177662	A1 9/2003 Elkington et al.	2013/0012856	A1	1/2013	Hammerslag et al.	
	2003/0204938	A1 11/2003 Hammerslag	2013/0014359	A1	1/2013	Chen	
	2004/0041452	A1 3/2004 Williams	2013/0019501	A1	1/2013	Gerber	
	2004/0211039	A1 10/2004 Livingston	2013/0091667	A1	4/2013	Zerfas et al.	
	2005/0054962	A1 3/2005 Bradshaw	2013/0092780	A1	4/2013	Soderberg et al.	
	2005/0060912	A1 3/2005 Holzer et al.	2013/0269219	A1	10/2013	Burns et al.	
	2005/0081339	A1 4/2005 Sakabayashi	2013/0277485	A1	10/2013	Soderberg et al.	
	2005/0081403	A1 4/2005 Mathieu	2013/0340283	A1	12/2013	Bell et al.	
	2005/0087115	A1 4/2005 Martin	2013/0345612	A1	12/2013	Bannister et al.	
	2005/0098673	A1 5/2005 Huang	2014/0082963	A1	3/2014	Beers	
	2005/0102861	A1 5/2005 Martin	2014/0094728	A1	4/2014	Soderberg et al.	
	2005/0126043	A1 6/2005 Reagan et al.	2014/0117140	A1	5/2014	Goodman et al.	
	2005/0172463	A1 8/2005 Rolla	2014/0123440	A1	5/2014	Capra et al.	
	2005/0184186	A1 8/2005 Tsoi et al.	2014/0123449	A1	5/2014	Soderberg et al.	
	2005/0198866	A1 9/2005 Wiper et al.	2014/0208550	A1	7/2014	Neiley	
	2006/0135901	A1 6/2006 Ingimundarson et al.	2014/0221889	A1	8/2014	Burns et al.	
	2006/0156517	A1 7/2006 Hammerslag et al.	2014/0290016	A1	10/2014	Lovett et al.	
	2006/0179685	A1 8/2006 Borel et al.	2014/0359981	A1	12/2014	Cotterman et al.	
	2006/0185193	A1 8/2006 Pellegrini	2015/0007422	A1	1/2015	Cavanagh et al.	
	2006/0287627	A1 12/2006 Johnson	2015/0014463	A1	1/2015	Converse et al.	
	2007/0006489	A1 1/2007 Case, Jr. et al.	2015/0026936	A1	1/2015	Kerns et al.	
	2007/0063459	A1 3/2007 Kavarsky	2015/0033519	A1	2/2015	Hammerslag et al.	
	2007/0068040	A1 3/2007 Farys	2015/0059206	A1	3/2015	Lovett et al.	
	2007/0084956	A1 4/2007 Chen	2015/0076272	A1	3/2015	Trudel et al.	
	2007/0113524	A1 5/2007 Lander	2015/0089779	A1	4/2015	Lawrence et al.	
	2007/0128959	A1 6/2007 Cooke	2015/0089835	A1	4/2015	Hammerslag et al.	
	2007/0169378	A1 7/2007 Sodeberg et al.	2015/0101160	A1	4/2015	Soderberg et al.	
	2008/0016717	A1 1/2008 Ruban	2015/0150705	A1	6/2015	Capra et al.	
	2008/0060167	A1 3/2008 Hammerslag et al.	2015/0151070	A1	6/2015	Capra et al.	
	2008/0060168	A1 3/2008 Hammerslag et al.	2015/0190262	A1	7/2015	Capra et al.	
	2008/0066272	A1 3/2008 Hammerslag et al.					

(56)

References Cited

U.S. PATENT DOCUMENTS

2015/0223608 A1 8/2015 Capra et al.
 2015/0237962 A1 8/2015 Soderberg et al.
 2015/0335458 A1 11/2015 Romo

FOREIGN PATENT DOCUMENTS

AT 361808 4/1981
 CA 2114387 1/1994
 CA 2112789 8/1994
 CH 41765 9/1907
 CH 111341 11/1925
 CH 199766 11/1938
 CH 204 834 A 8/1939
 CH 523 669 7/1972
 CH 562 015 5/1975
 CH 577 282 7/1976
 CH 612 076 7/1979
 CH 624 001 7/1981
 CN 2613167 4/2004
 CN 201015448 2/2008
 DE 555211 7/1932
 DE 641976 2/1937
 DE 7043154 11/1970
 DE 1 785 220 5/1971
 DE 2 062 795 6/1972
 DE 23 41 658 3/1974
 DE 24 14 439 10/1975
 DE 29 00 077 A1 7/1980
 DE 2914280 A1 10/1980
 DE 31 01 952 A1 9/1982
 DE 36 26 837 2/1988
 DE 38 13 470 11/1989
 DE 3822113 C2 1/1990
 DE 9413147 6/1994
 DE 43 02 401 A1 8/1994
 DE 43 05 671 9/1994
 DE 9308037 10/1994
 DE 43 24 049 2/1995
 DE 9315776 2/1995
 DE 196 24 553 1/1998
 DE 19700309 A1 7/1998
 DE 19945045 A1 3/2001
 DE 201 16 755 U1 1/2002
 DE 20 2010 000 354 U1 6/2010
 DE 11 2013 005 273 T5 9/2015
 EP 0 056 953 8/1982
 EP 0079874 A1 5/1983
 EP 0 099 504 2/1984
 EP 0 123 050 2/1984
 EP 0 155 596 9/1985
 EP 0 201 051 11/1986
 EP 0 255 869 7/1987
 EP 0 393 380 3/1990
 EP 0 589 232 3/1994
 EP 0 589 233 A1 3/1994
 EP 0 614 625 A1 9/1994
 EP 0 651 954 A1 5/1995
 EP 0 679 346 11/1995
 EP 0 693 260 B1 1/1996
 EP 0 717 942 6/1996
 EP 0 734 662 A1 10/1996
 EP 0 848 917 6/1998
 EP 0 923 965 6/1999
 EP 0 937 467 8/1999
 EP 1163860 12/2001
 EP 1 219 195 7/2002
 EP 1 236 412 A 9/2002
 EP 2298107 B1 3/2011
 EP 2359708 8/2011
 FR 1 349 832 3/1963
 FR 1 404 799 7/1965
 FR 2 019 991 A 7/1970
 FR 2 108 428 9/1971
 FR 2 175 684 3/1972
 FR 2.108.429 5/1972

FR 2 565 795 6/1984
 FR 2 598 292 A1 11/1987
 FR 2 726 440 A1 5/1996
 FR 2 770 379 A1 5/1999
 FR 2 814 919 A1 4/2002
 GB 189911673 0/1899
 GB 216400 8/1923
 GB 2 449 722 A 12/2008
 IT 1220811 B 6/1990
 IT PD 2003 A 000197 4/2003
 IT PD 2003 A 000198 4/2003
 JP 49-28618 3/1974
 JP 51-2776 1/1976
 JP 51-121375 10/1976
 JP 51-131978 10/1976
 JP 53-124987 3/1977
 JP 54-108125 2/1978
 JP 62-57346 4/1987
 JP 63-80736 5/1988
 JP H02-236025 9/1990
 JP 7-000208 6/1995
 JP 6-284906 2/1996
 JP 3031760 9/1996
 JP 3030988 11/1996
 JP 8308608 11/1996
 JP 10-199366 7/1998
 JP 2004-016732 1/2004
 JP 2004-041666 2/2004
 JP 2009-504210 2/2009
 KR 20-0367882 11/2004
 KR 20-0400568 8/2005
 KR 10-0598627 7/2006
 KR 10-0953398 4/2010
 KR 10-1025134 B1 3/2011
 KR 10-1028468 4/2011
 KR 10-1053551 7/2011
 WO 94/27456 12/1994
 WO 95/03720 2/1995
 WO 95/11602 5/1995
 WO 98/33408 8/1998
 WO 98/37782 9/1998
 WO 99/09850 3/1999
 WO 99/15043 4/1999
 WO 99/43231 9/1999
 WO 00/53045 9/2000
 WO 00/76337 A1 12/2000
 WO 01/08525 2/2001
 WO 01/15559 3/2001
 WO WO02/051511 7/2002
 WO 2004/093569 11/2004
 WO 2005/013748 A1 2/2005
 WO 2007/016983 2/2007
 WO 2008/015214 2/2008
 WO 2008/033963 3/2008
 WO 2009/134858 11/2009
 WO 2010/059989 A2 5/2010
 WO 2012/165803 A2 12/2012
 WO 2015/035885 3/2015
 WO 2015/179332 A1 11/2015
 WO 2015/181928 A1 12/2015

OTHER PUBLICATIONS

U.S. Appl. No. 09/956,987, filed Sep. 18, 2001, Hammerslag, Including its prosecution history.
 "Strength of materials used to make my Safety Harnesses," Elaine, Inc. Jul. 9, 2012. Retrieved from <https://web.archive.org/web/20120709002720/http://www.childharness.ca/strength_data.html> on Mar. 17, 2014, 2 pages.
 International Search Report and Written Opinion for PCT/US2013/032326 mailed Jun. 14, 2013, 27 pages.
 International Preliminary Report on Patentability for PCT/US2013/032326 issued Sep. 16, 2014, 6 pages.
 International Search Report and Written Opinion for PCT/US2013/057637 mailed Apr. 7, 2014, 34 pages.
 International Preliminary Report on Patentability for PCT/US2013/057637 issued Mar. 3, 2015, 9 pages.

(56)

References Cited

OTHER PUBLICATIONS

International Search Report and Written Opinion for PCT/US2013/068342 mailed Apr. 7, 2014, 29 pages.

International Preliminary Report on Patentability for PCT/US2013/068342 issued May 5, 2015, 9 pages.

International Search Report and Written Opinion for PCT/US2014/014952 mailed Apr. 25, 2014, 17 pages.

International Preliminary Report on Patentability for PCT/US2014/014952 issued Aug. 11, 2015, 9 pages.

International Search Report and Written Opinion for PCT/US2014/066212 mailed Apr. 22, 2015, 16 pages.

International Search Report and Written Opinion for PCT/US2014/032574 mailed Oct. 31, 2014, 19 pages.

International Search Report and Written Opinion for PCT/US2014/045291 mailed Nov. 6, 2014, 12 pages.

International Search Report and Written Opinion for PCT/US2014/013458 mailed May 19, 2014, 12 pages.

International Preliminary Report on Patentability for PCT/US2014/013458 issued Jul. 28, 2015, 7 pages.

International Search Report and Written Opinion for PCT/US2013/068814 mailed Jun. 9, 2014, 18 pages.

International Preliminary Report on Patentability for PCT/US2013/068814 issued May 12, 2015, 12 pages.

Notice of Reasons for Rejection from the Japanese Patent Office dated Feb. 26, 2015 for design application No. 2014-015570, 4 pages.

Receipt of Certificate of Design Registration No. 1529678 from the Japanese Patent Office for design application No. 2014-015570 dated Jun. 26, 2015, 1 page.

International Search Report and Written Opinion for PCT/US2014/055710 mailed Jul. 6, 2015, 19 pages.

International Search Report and Written Opinion for PCT/US2014/054420 mailed Jul. 6, 2015, 21 pages.

The Preliminary Rejections from the Korean Intellectual Property Office for Application No. 30-2014-34959 received Aug. 7, 2015, is

not translated into English. The document requests a renaming of the application to be in accordance with Korean patent law, 5 pages total.

The Preliminary Rejections from the Korean Intellectual Property Office for Application No. 30-2014-34959 received Apr. 7, 2015, is not translated into English. The document requests a revision of the drawings to be in accordance with Korean patent law, 6 pages total. Office Action received Oct. 8, 2015 from the German Patent and Trademark Office for Appln No. 402015100191.2, regarding the title of the invention, 2 pages.

Notice of Reasons for Rejection from the Japanese Patent Office dated Oct. 5, 2015 for design application No. 2015-004923, 4 pages. International Search Report and Written Opinion for PCT/US2014/046238 mailed Nov. 21, 2014, 17 pages.

International Search Report and Written Opinion for PCT/US2014/020894 mailed Jun. 20, 2014, 12 pages.

International Search Report and Written Opinion for PCT/US2014/041144 mailed Dec. 10, 2014, 13 pages.

"Save Tourniquet," 3 pages. Copyright 2015. Accessed on Dec. 11, 2015. Retrieved from <http://www.savetourniquet.com/>.

Certificate of Design Registration No. 30-809409 on Aug. 3, 2015 from the Korean Intellectual Property Office for Appln No. 30-2015-11475, 2 pages.

Certificate of Design Registration No. 30-809410 on Aug. 3, 2015 from the Korean Intellectual Property Office for Appln No. 30-2015-11476, 2 pages.

European Search Report for EP 14168875 mailed Oct. 29, 2014, 9 pages.

Anonymous, "Shore durometer," Wikipedia, the free encyclopedia, Mar. 10, 2012, XP002747470, Retrieved from the Internet: URL: https://en.wikipedia.org/w/index.php?title=Shore_durometer&oldid=481128180 [retrieved on Oct. 20, 2015] * shore A, shore D, durometer, polymer, rubber, gel; the whole document *, 6 pages. Asolo® Boot Brochure Catalog upon information and belief date is as early as Aug. 22, 1997, 12 pages.

* cited by examiner

100

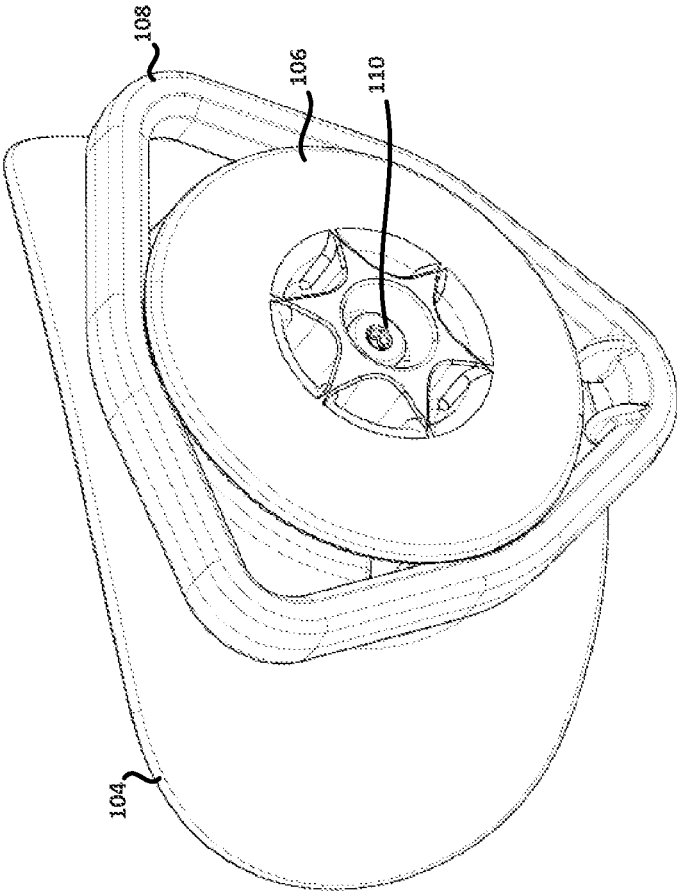

FIG. 1

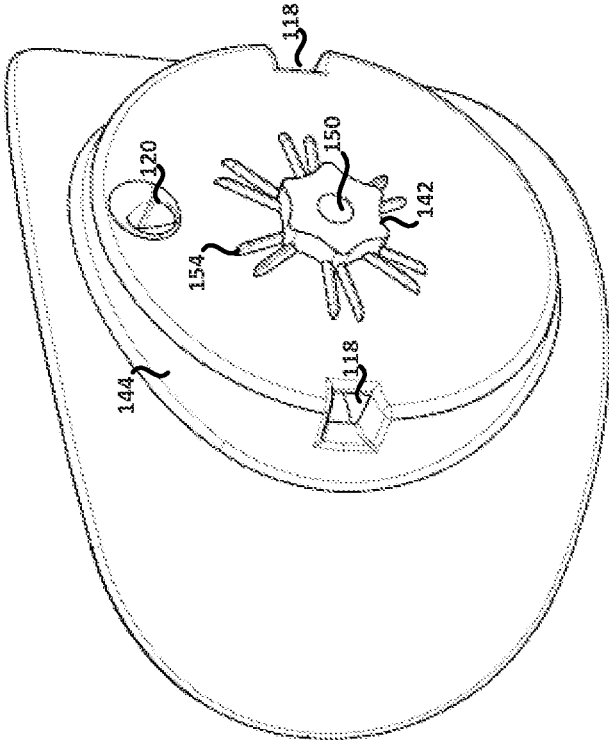

FIG. 2

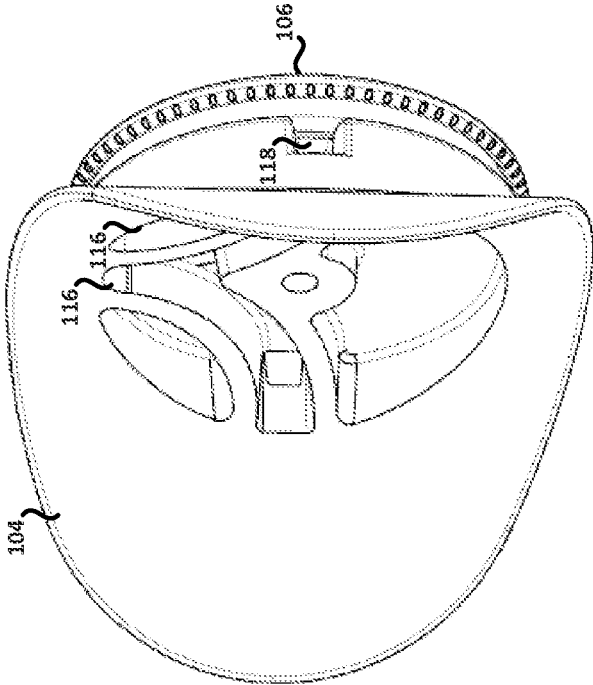

FIG. 3

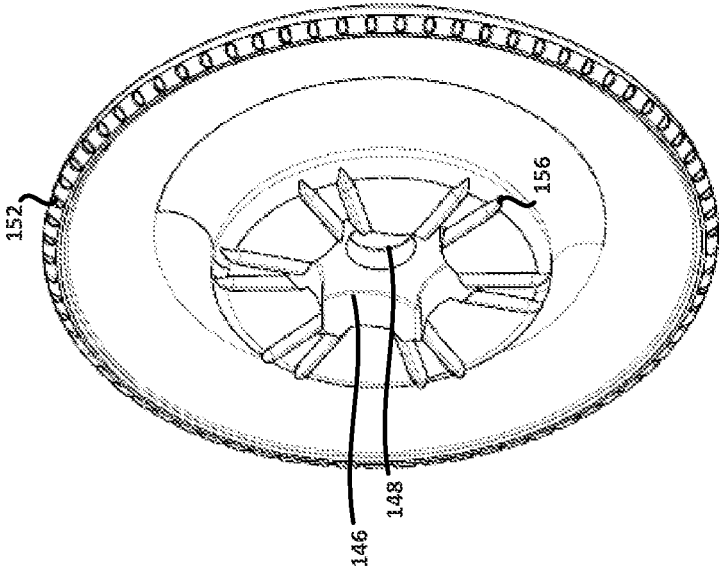

FIG. 4

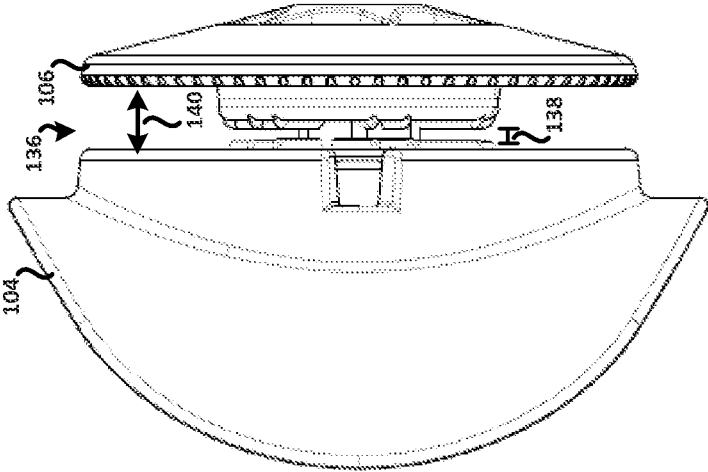

FIG. 5

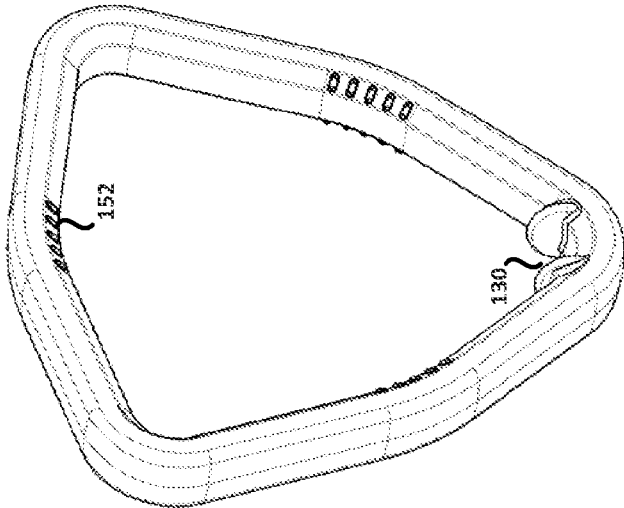

FIG. 6

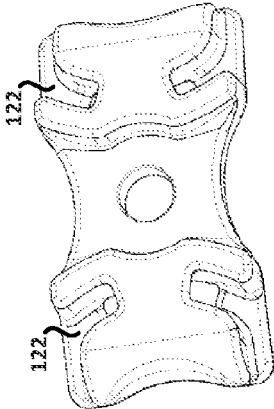

FIG. 7A

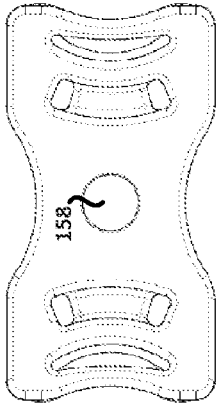

FIG. 7B

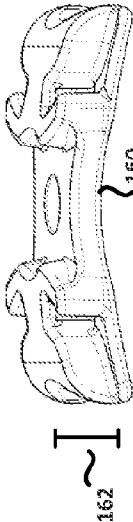

FIG. 7C

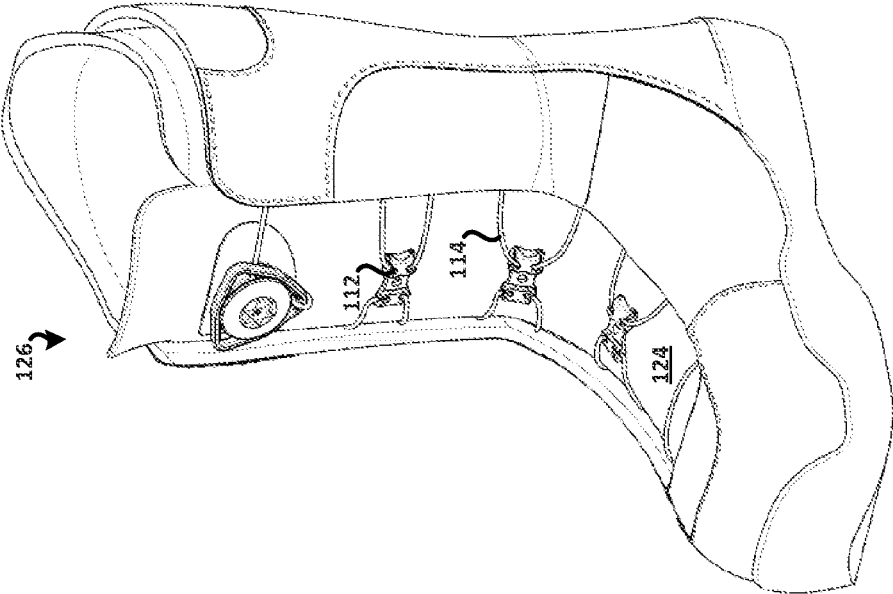

FIG. 8A

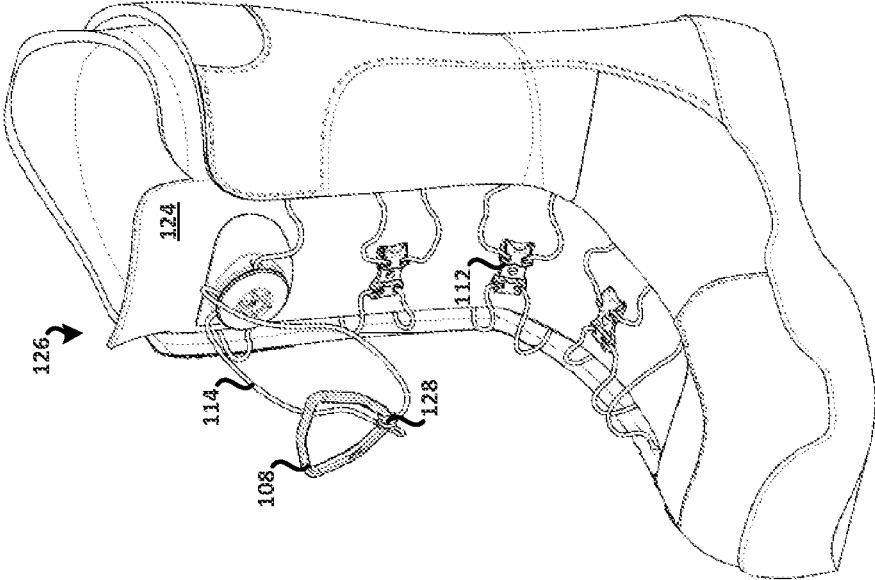

FIG. 8B

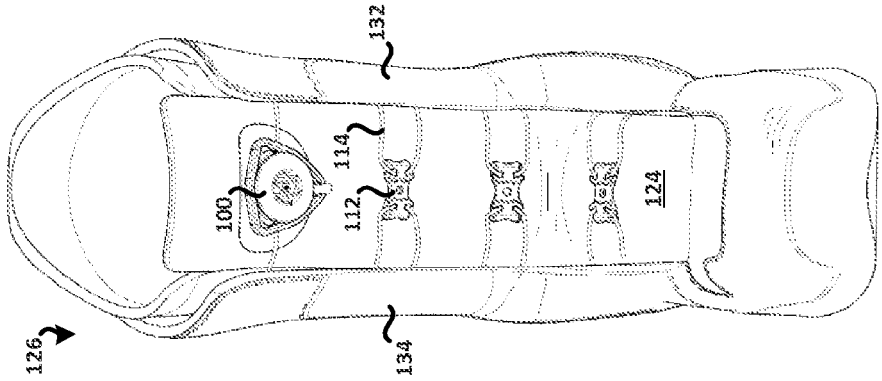

FIG. 8C

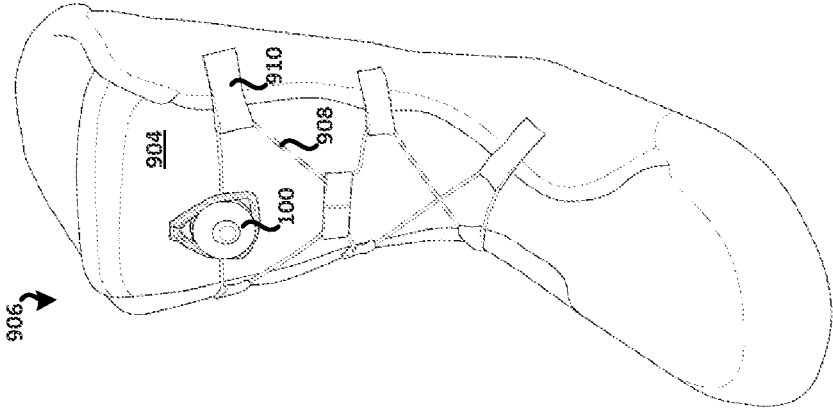

FIG. 9

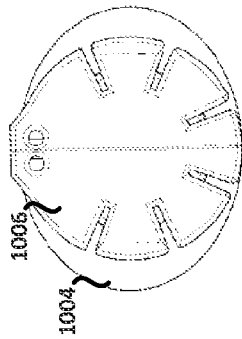

FIG. 10A

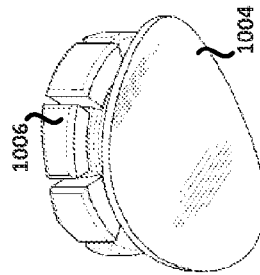

FIG. 10C

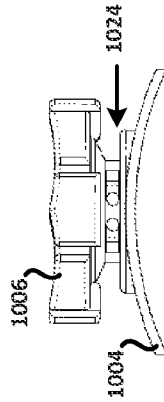

FIG. 10B

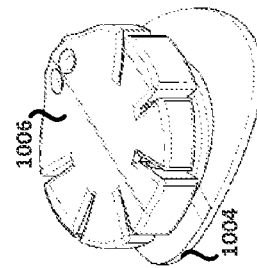
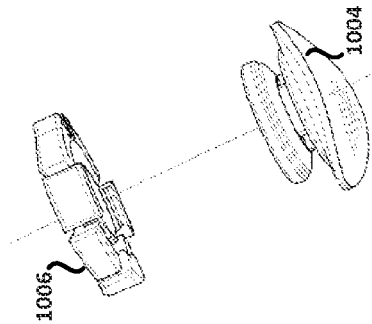
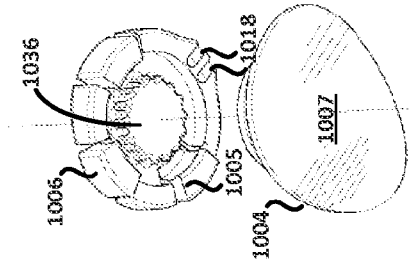
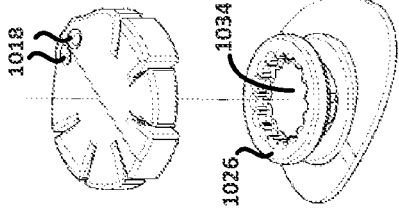

FIG. 10D



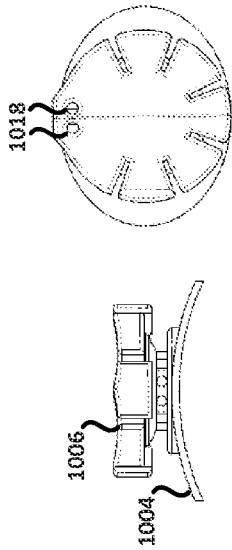

FIG. 12A

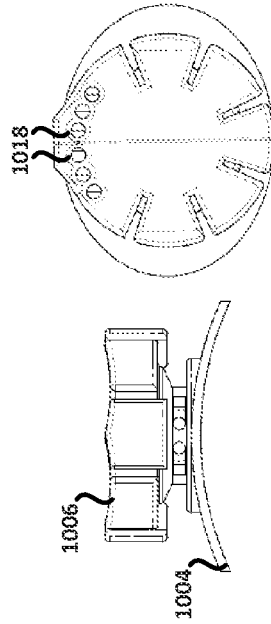

FIG. 12B

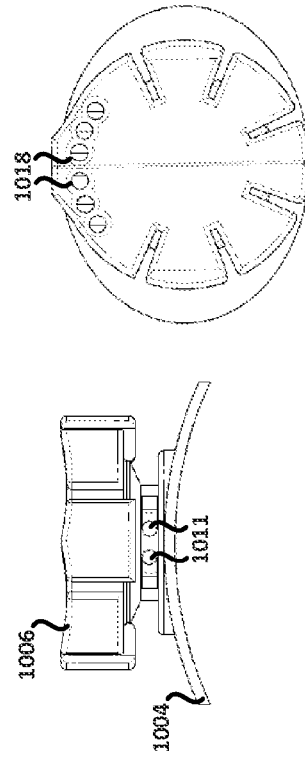

FIG. 12C

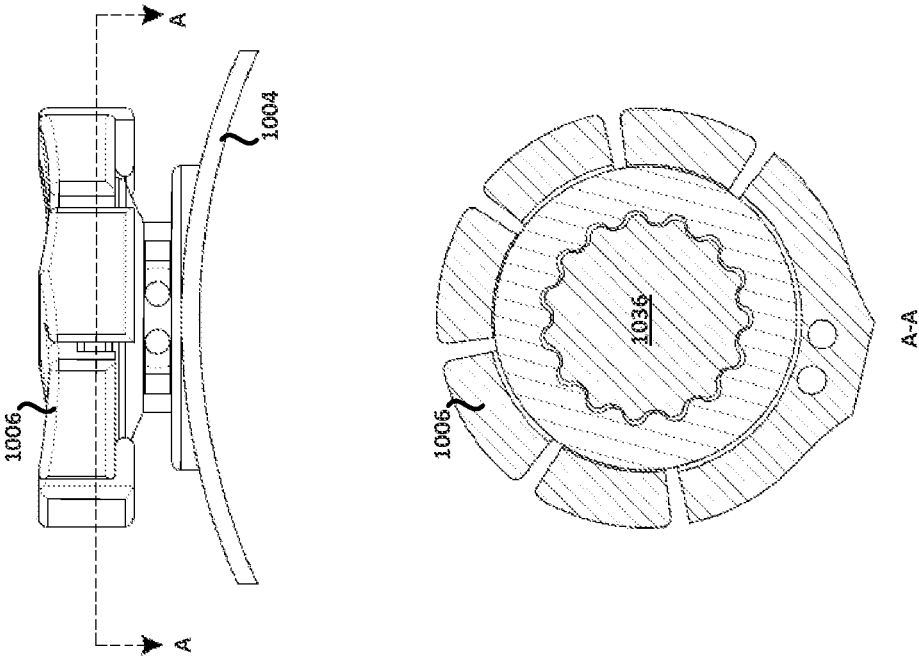

FIG. 13

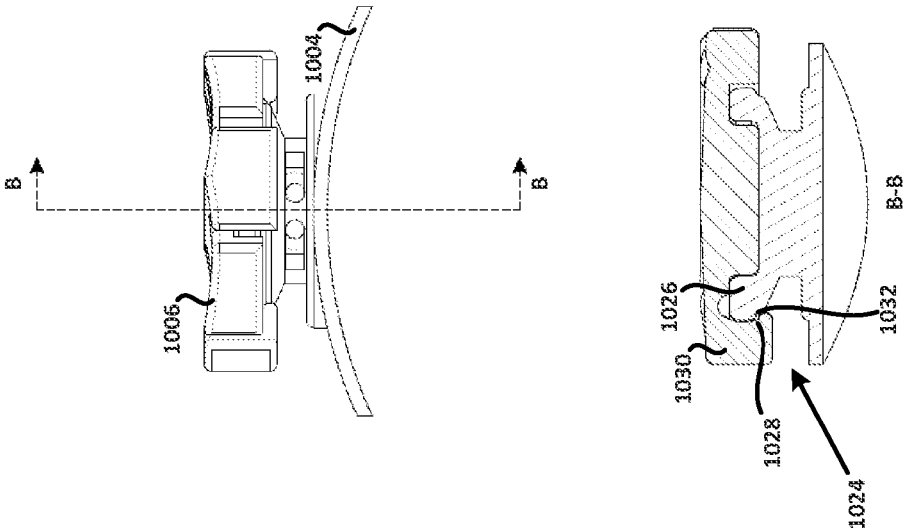

FIG. 14

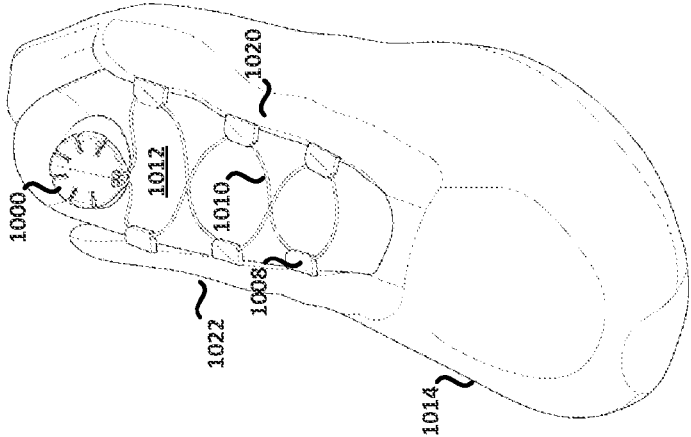

FIG. 15

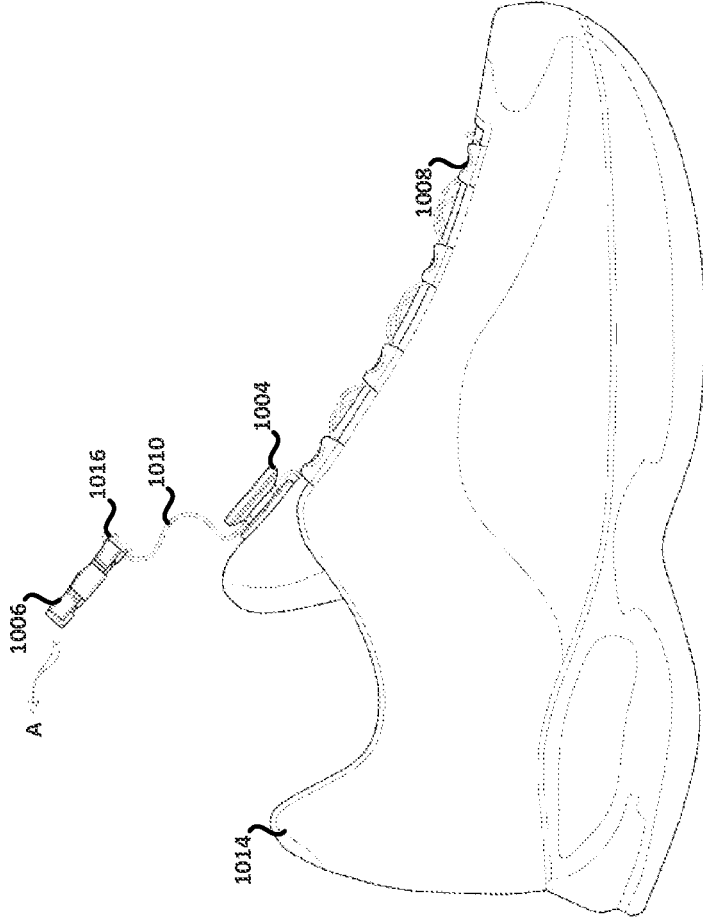

FIG. 16A

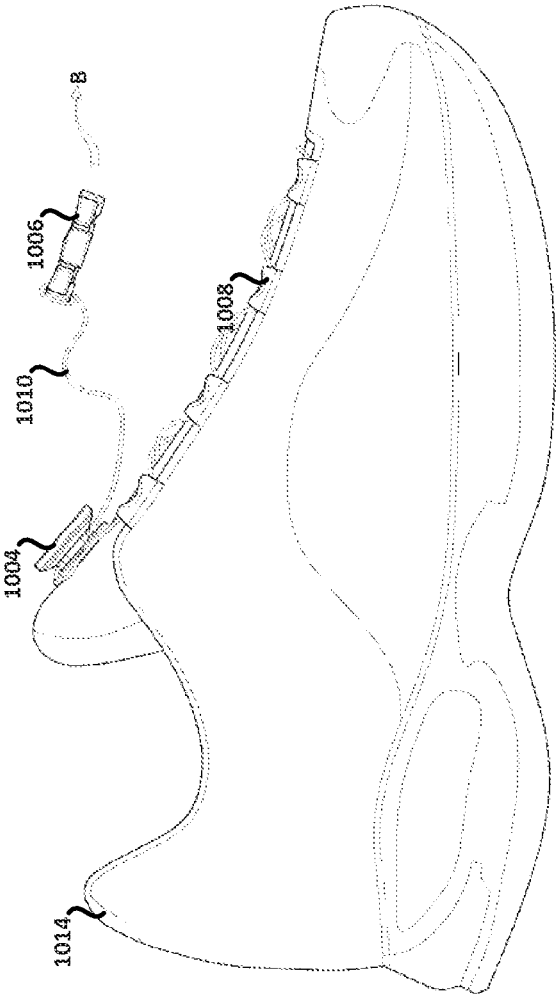

FIG. 16B

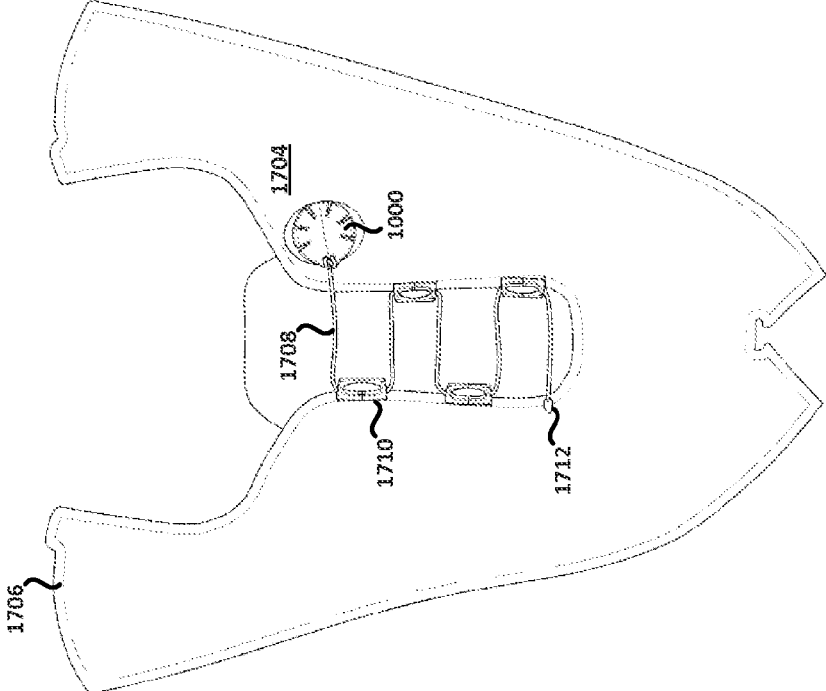

FIG. 17

1702

1802

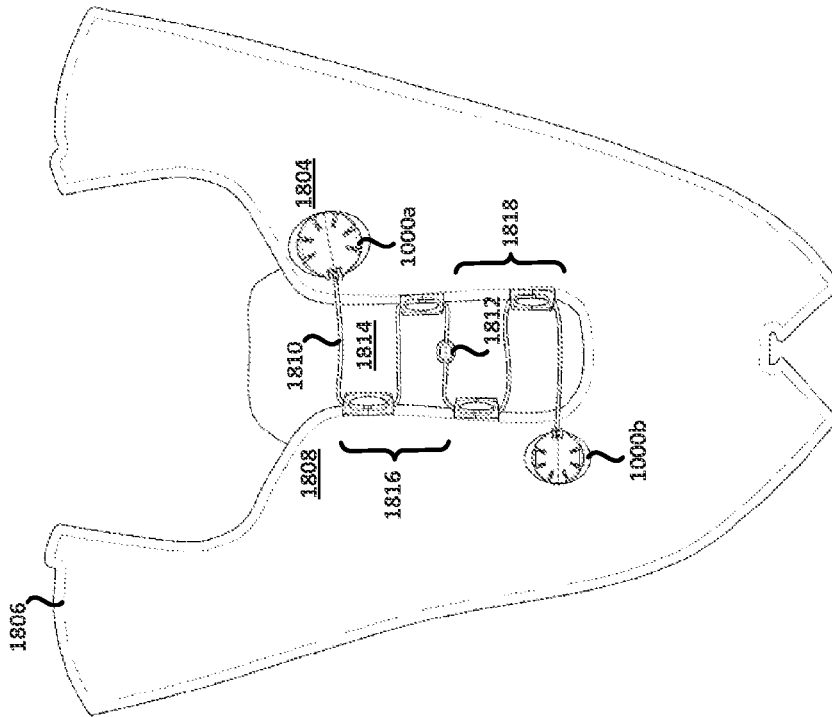

FIG. 18

1902

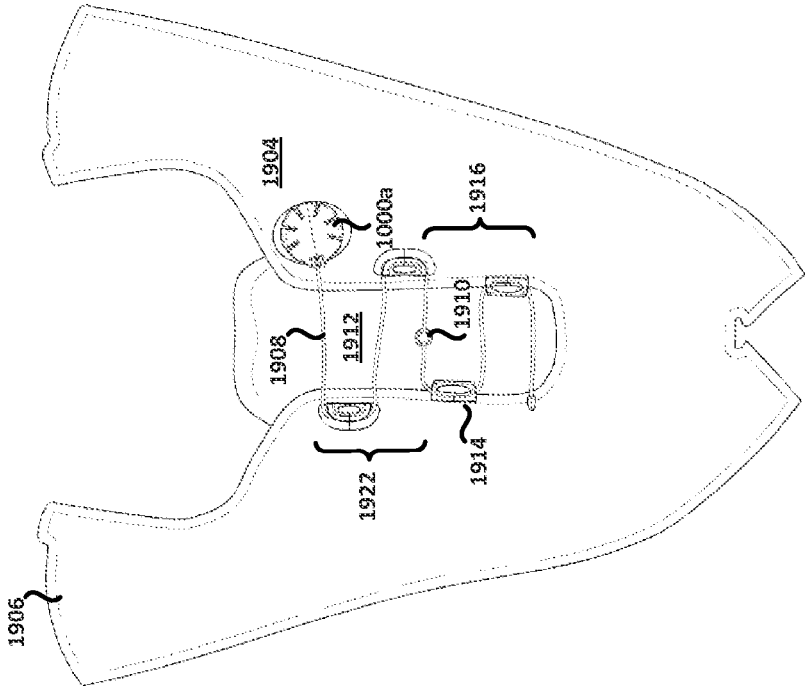

FIG. 19A

1902

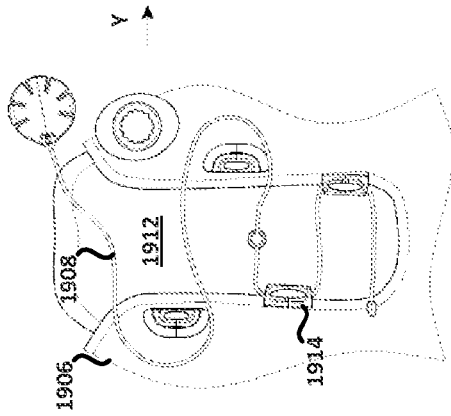

FIG. 19B

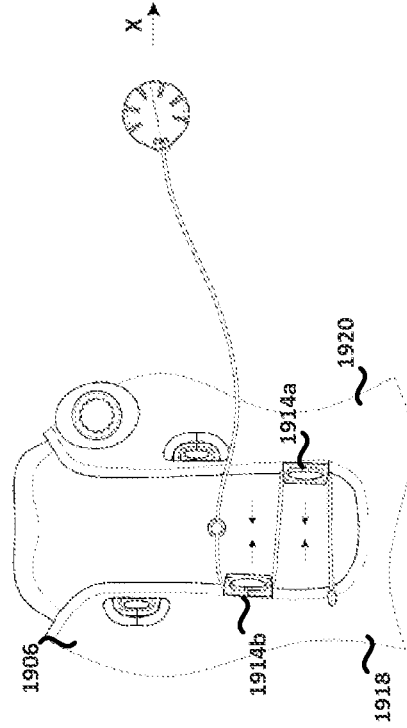

FIG. 19C

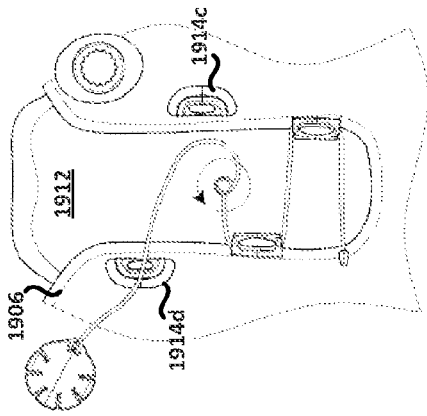

FIG. 19D

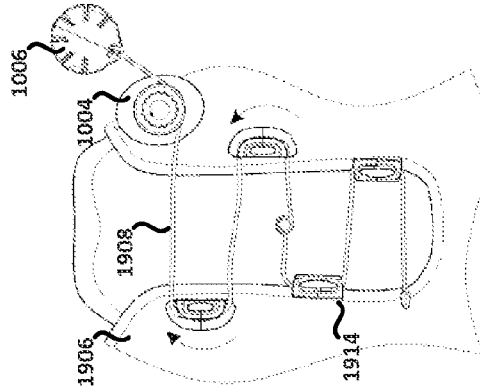

FIG. 19E

1902

2002

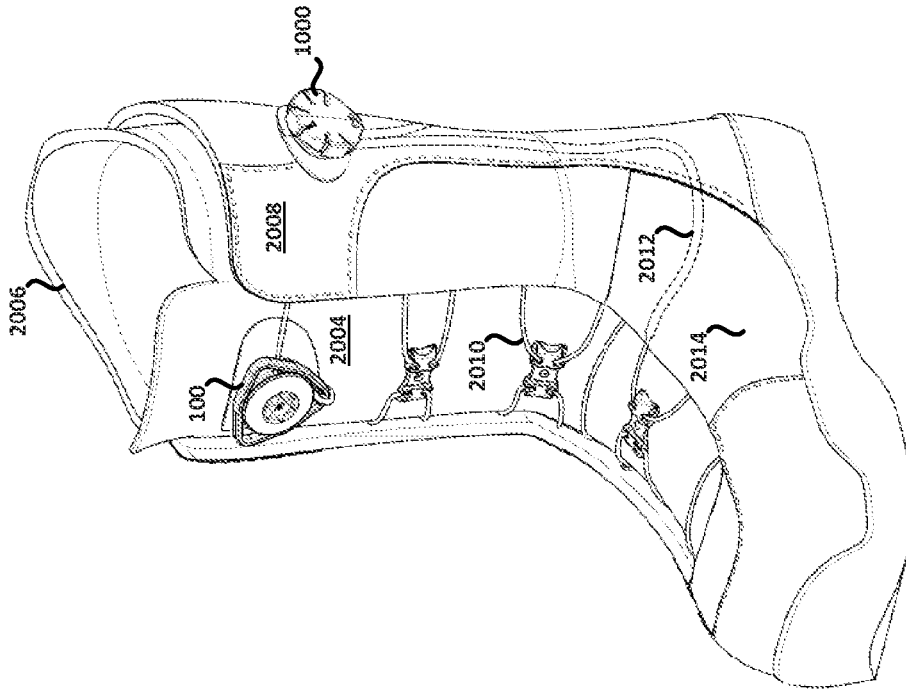

FIG. 20

2102

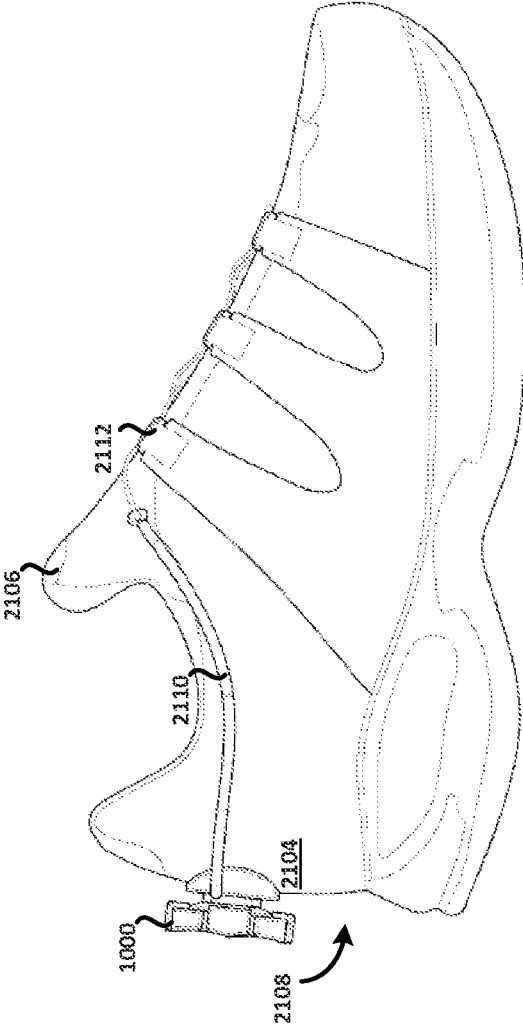

FIG. 21

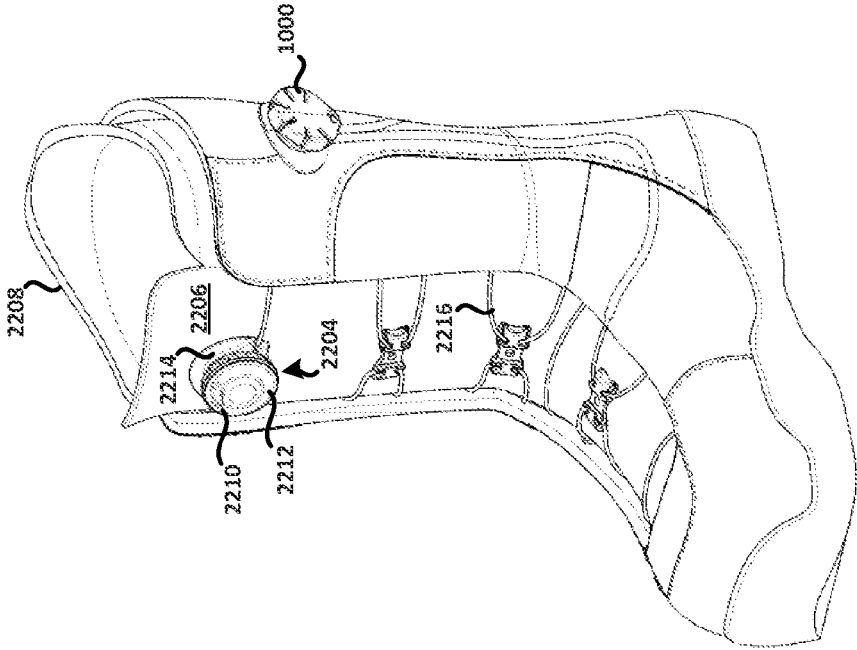

FIG. 22

2300

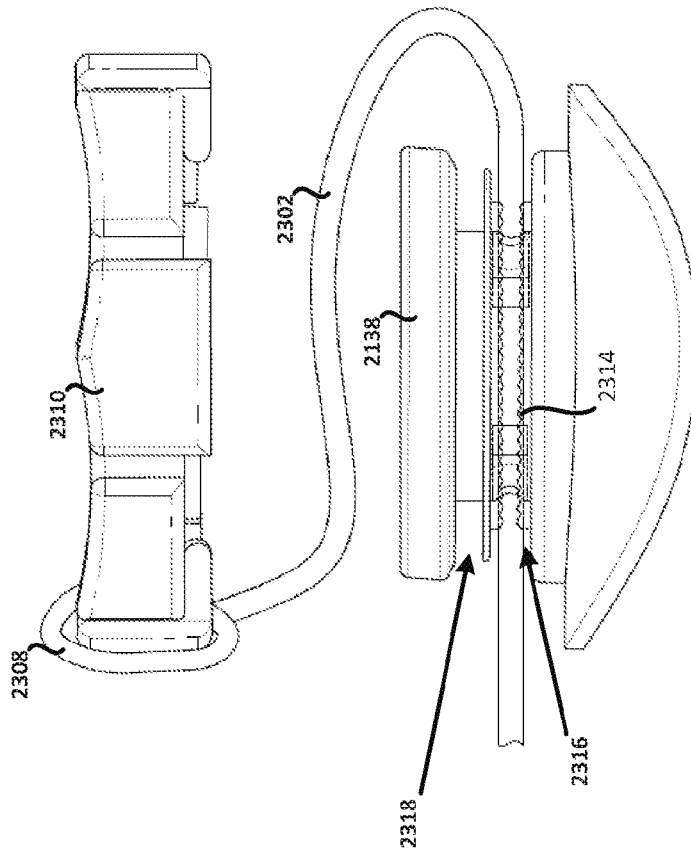

FIG. 23A

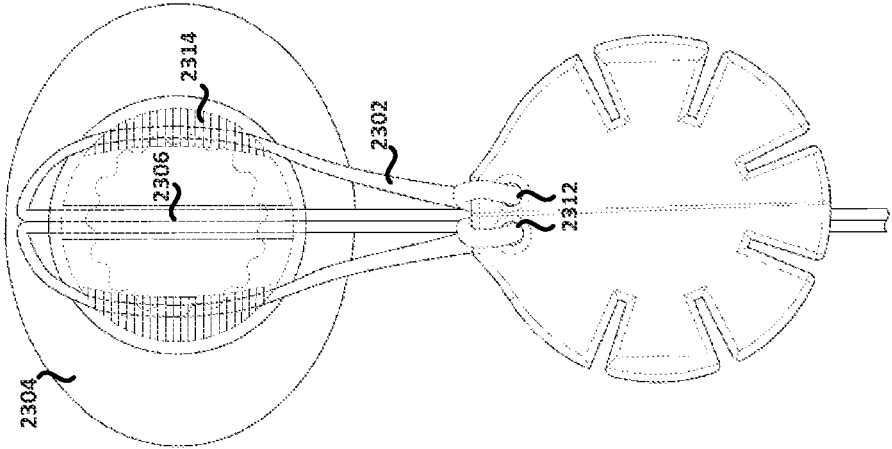

FIG. 23B

2300

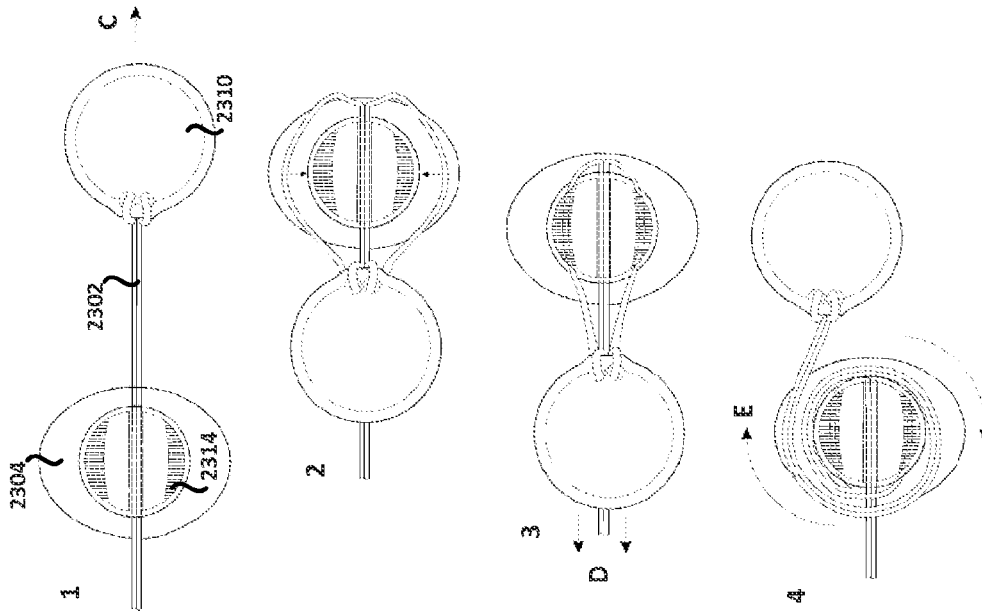

FIG. 23C

2300

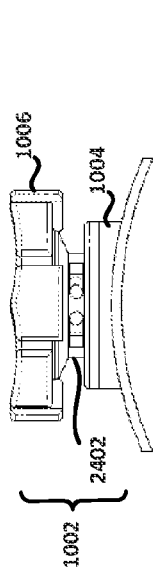

FIG. 24A

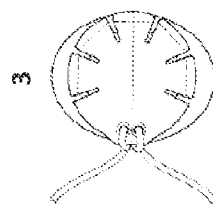
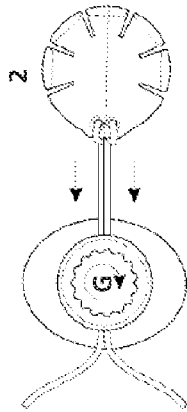
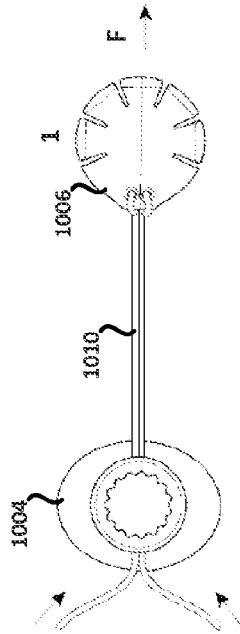

FIG. 24B

2400

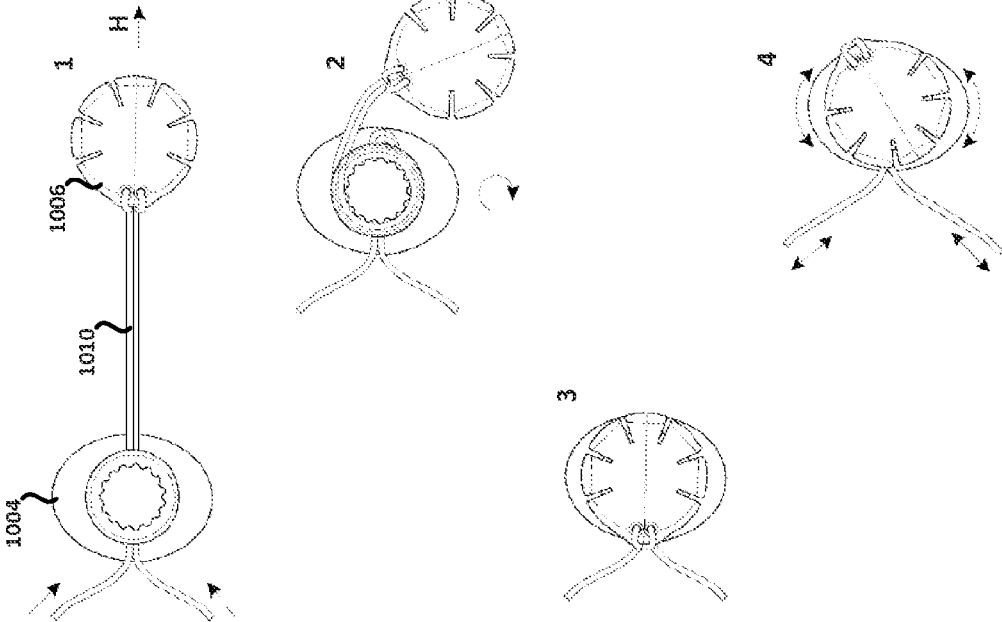

FIG. 25

2500

LACE FIXATION ASSEMBLY AND SYSTEM

Matter enclosed in heavy brackets [] appears in the original patent but forms no part of this reissue specification; matter printed in italics indicates the additions made by reissue; a claim printed with strikethrough indicates that the claim was canceled, disclaimed, or held invalid by a prior post-patent action or proceeding.

CROSS-REFERENCE TO RELATED APPLICATION

This application is a reissue divisional application of U.S. Reissue application Ser. No. 16/130,943, which is an application for reissue of U.S. Pat. No. 9,439,477, issued Sep. 13, 2016 from U.S. application Ser. No. 14/166,799, filed Jan. 28, 2014, entitled "LACE FIXATION ASSEMBLY AND SYSTEM," which claims the benefit of U.S. Provisional Patent Application No. 61/757,692, filed Jan. 28, 2013, entitled LACE FIXATION SYSTEM WITH LOW FRICTION GUIDES, the entirety of which is incorporated by reference for all purposes.

More than one reissue application has been filed for the reissue of U.S. Pat. No. 9,439,477. The reissue applications are U.S. application Ser. No. 16/130,943, U.S. application Ser. No. 16/826,150, and U.S. application Ser. No. 16/826,105 (the present application). U.S. application Ser. No. 16/826,150 and U.S. application Ser. No. 16/826,105 are reissue divisional applications of U.S. application Ser. No. 16/130,943.

SUMMARY

Various lace fixation assemblies and systems beneficial to both manufacturers and users. In particular, the lace fixation assemblies and systems of the present disclosure may provide an easy to understand and easy to use means of adjusting and securing the closure of an article of footwear or other item. The lace fixation assemblies and systems of the present disclosure may further allow the use of small-diameter, low-friction lace material that does not require gripping by hand to secure or tighten. The lace fixation assemblies and systems of the present disclosure may further provide a convenient means to store excess lace after tightening while allowing quick and easy release and refastening of the fixation for secondary tension adjustment. The lace fixation assemblies and systems of the present disclosure may further be of a design and material such as plastic or other synthetic material that is economical to produce and to incorporate into existing manufacturing methods.

For example, in a first aspect, a lacing system for tightening an article is disclosed. The lacing system may include or comprise a fixation member coupled to the article, the fixation member having at least one entry aperture and an exit aperture with a lumen extending therebetween, the fixation member also having a spool with a fixation post. In this example, the fixation member may be rigidly fastened to the article. The lumen may include or comprise of a passage, a cavity, a tube structure, or the like. Further, the spool may include or comprise of a flanged cylinder whereby an element may be wound around or to the post. Other embodiments are possible.

The lacing system may further include or comprise a tension member having an intermediate portion slidably disposed within the lumen of the fixation member such that a proximal portion of the tension member is positioned on a

proximal side of the fixation member and a distal portion of the tension member is positioned on a distal side of the fixation member and such that a length of the proximal portion and a length of the distal portion is adjustable via sliding of the tension member within the lumen. In this example, the tension member may include or comprise a lace or lacing that has a particular diameter. The tension member may generally be laced to the fixation member, and a length of the tension member protruding or exiting from the fixation member may be adjusted as desired. Other embodiments are possible.

The lacing system may further include or comprise a plurality of guide members coupled to the article on the proximal side of the fixation member to guide the proximal portion of the tension member along the article to the fixation member. In this example, the tension member may generally be laced to each of the plurality of guide members. Other embodiments are possible. The lacing system may further include or comprise a tensioning component coupled to the distal portion of the tension member to effect sliding of the tension member within the lumen and thereby tighten the article by adjusting the length of the proximal portion of the tension member, and to maintain a tightness of the article by winding of the tension member about the fixation post, wherein the tensioning component is securable to the spool of the fixation member. In this example, the tension member together with other elements or features of the example lacing system may be used to tighten the article whereby the tension may be stored to the spool. Other embodiments are possible.

Additionally, or alternatively, the fixation member of the lacing system may include a flange shaped complementary to the panel. Additionally, or alternatively, the lumen of the lacing system may extend between the entry aperture and the exit apertures in an arcuate configuration, so that the lumen may be guided through the fixation member in a gentle manner with minimized frictional resistance. Additionally, or alternatively, the plurality of guide members the lacing system may be configured to direct lacing along the panel of the article with or without overlap to the at least one lacing entry aperture and through the lacing exit aperture. Such a feature may be selected as desired and may be implementation-specific. Additionally, or alternatively, the tensioning component of the lacing system may be a ring-shaped element that may be snap-fit coupleable to the spool protrusion. Additionally, or alternatively, the spool protrusion and the tensioning component of the lacing system may each comprise a plurality of traction members that when engaged inhibit rotation of the tensioning component when the tensioning component is secured to the spool protrusion. Such a feature may prevent unwanted or undesired loosening of the tension member when the tensioning component is positioned to the spool protrusion. Other embodiments are possible.

In another aspect, a lacing system for tightening an article is disclosed. The lacing system may include or comprise first plate coupleable to a first panel of the article and defining at least one lacing entry aperture, a lacing exit aperture, and a keyed protrusion that is positioned to a complementary recess of a second plate of the lacing system to form a groove with a lacing fixation post. In this example, the keyed protrusion and complementary recess may facilitate secure coupling of the first plate with the second plate. Other embodiments are possible. The lacing system may further include or comprise a lacing tensioner coupleable to lacing protruding from the lacing exit aperture and to a periphery of the groove so that the lacing tensioner is securable to the

groove when lacing protruding from the lacing exit aperture is wound to the lacing fixation post for tightening the article by pulling together a second panel and a third panel of the article. Other embodiments are possible.

Additionally, or alternatively, the first plate of the lacing system may further define a first plurality of ridged flutes extending radially from the keyed protrusion in a spoke pattern, and the second plate further defining a second plurality of ridged flutes extending radially from the recess in the spoke pattern and offset the first plurality of ridged flutes. Such a feature may maintain lacing tension when lacing protruding from the lacing exit aperture is wound to the lacing fixation post for tightening the article. Additionally, or alternatively, the lacing system may include a plurality of lacing guide members coupleable to the first panel to direct lacing along the first panel to the at least one lacing entry aperture and through the lacing exit aperture. Additionally, or alternatively, the lacing system may include a fastener positioned through an aperture of the keyed protrusion and an aperture of the recess to rigidly secure the keyed protrusion to the recess. Other embodiments are possible.

In another aspect, a method for tightening an article using a lacing system is disclosed. The lacing system may include one or more of the features: a fixation member coupled to the article, the fixation member having at least one entry aperture and an exit aperture with a lumen extending therebetween, and also having a spool with a fixation post; a tension member having an intermediate portion slidably disposed within the lumen of the fixation member so that a proximal portion of the tension member is positioned on a proximal side of the fixation member and a distal portion of the tension member is positioned on a distal side of the fixation member; a plurality of guide members coupled to the article on the proximal side of the fixation member to guide the proximal portion of the tension member along/about the article to the fixation member; and a tensioning component coupled to the distal portion of the tension member. Further, the method may include or comprise tensioning the tension member via the tensioning component to effect sliding of the tension member within the lumen and thereby tighten the article by shortening the length of the proximal portion of the tension member. The method may further include or comprise winding the tension member about the fixation post via the tensioning component to maintain a tightness of the article, wherein the tensioning component is securable to the spool of the fixation member.

Additionally, or alternatively, the method may include or comprise securing the tensioning component to the spool of the fixation member. Such a feature may allow for storage of the tensioning component when not in use. Additionally, or alternatively, the method may include or comprise positioning the tension member to the lumen of the fixation member to lace the tension member to the fixation member. Additionally, or alternatively, the method may include or comprise positioning the tension member to the plurality of guide members to lace the tension member to the plurality of guide members with or without overlap of the tension member. Additionally, or alternatively, the method may include or comprise positioning the tension member to the tensioning component to couple the tension member to the tensioning component. Additionally, or alternatively, the method may include or comprise winding the tension member within a gap about the fixation post that includes a plurality of radially offset ridged flutes to engage and maintain tension to the tension member. Additionally, or alternatively, the method may include or comprise winding

excess length of the tension member within a gap about the fixation post to store the excess length of tension member about the fixation post. Other embodiments are possible.

Although not so limited, an appreciation of the various aspects of the present disclosure along with associated benefits and/or advantages may be gained from the following discussion in connection with the drawings.

DESCRIPTION OF THE DRAWINGS

FIG. 1 shows a first lace fixation assembly.

FIG. 2 shows a first plate of the assembly of FIG. 1.

FIG. 3 show a first view of a first and second plate of the assembly of FIG. 1.

FIG. 4 shows a second plate of the assembly of FIG. 1.

FIG. 5 show a second view of a first and second plate of the assembly of FIG. 1.

FIG. 6 shows a tensioning component of the assembly of FIG. 1.

FIGS. 7A-C show various views of a guide member of a first lace fixation system.

FIGS. 8A-C show various views of a first lace fixation system.

FIG. 9 shows a view of another lace fixation system.

FIGS. 10A-D show various views of a second lace fixation assembly.

FIGS. 11A-C show various exploded views of the assembly of FIG. 9.

FIGS. 12A-C show multiple embodiments of the assembly of FIG. 9.

FIG. 13 shows a first cross-section A-A of the assembly of FIG. 9.

FIG. 14 shows a second cross-section B-B of the assembly of FIG. 9.

FIG. 15 shows a view of still another lace fixation system.

FIGS. 16A-B show various views of still another lace fixation system.

FIG. 17 shows a view of still another lace fixation system.

FIG. 18 shows a view of still another lace fixation system.

FIGS. 19A-E show various views of still another lace fixation system.

FIG. 20 shows a view of still another lace fixation system.

FIG. 21 shows a view of still another lace fixation system.

FIG. 22 shows a view of still another lace fixation system.

FIGS. 23A-C show various views of a third lace fixation assembly.

FIGS. 24A-B show various views of a fourth lace fixation assembly.

FIG. 25 shows various views of a fifth lace fixation assembly.

In the appended figures, similar components and/or features may have the same numerical reference label. Further, various components of the same type may be distinguished by following the reference label by a letter that distinguishes among the similar components and/or features. If only the first numerical reference label is used in the specification, the description is applicable to any one of the similar components and/or features having the same first numerical reference label irrespective of the letter suffix.

DETAILED DESCRIPTION

Different methods for closing or tightening shoes or boots and other flexible or semi-rigid panels have evolved over the years. Conventional laces whether led through metal eyelets, webbing loops, or low friction guides, have stood the test of time and remain popular. Mechanical systems using rotary

dials, serrated grip surfaces and other designs may provide alternatives to knot-secured laces. Hook and loop engagements as well as elastic straps may also serve well in some applications. Currently available designs though present certain drawbacks. For example, conventional laces require the tying of a knot to secure the tightened adjustment, which obligates the user to untie the knot before any secondary adjustment can be made, unless or until the knot loosens of its own accord, requiring retying. Conventional lace systems are also limited to the use of relatively large diameter laces that are comfortable to grip by hand, the opposite desired characteristics for low-profile, efficient and effective closure. Rotary dials and other mechanical systems eliminate the knot problem and can make use of small diameter laces, but tend to be expensive to manufacture, to the point that they can represent up to 50% of the cost of a given pair of footwear. Some knotless fixation systems self-store excess lace while others require excess lace to be gathered and placed into a pocket on the boot, which is an inconvenient and inelegant solution.

Given the harsh environment of daily use, often in climate extremes, mechanical system latching performance may also be problematic, often when a secure closure is needed most. Hook and loop and elastic systems also suffer performance loss in wet and/or freezing conditions, while being limited in the adjustment range and security of their closure. In addition to fixation issues, many lace systems suffer from excessive friction which can prevent the lace from exerting sufficient closure force in the area farthest from the point where tension is applied. This friction can have many causes including the lace material characteristic, the lace turning guides, the sliding of the lace over high friction surfaces, and also the points at which opposing laces cross over one another. In this aspect of lace function, the dilemma becomes one in which the more tension applied to tighten the closure, the more frictional force is created and the more difficult it becomes to obtain the desired closure. The present disclosure addresses these and other issues by providing a non-complex, inexpensive, non-mechanical, low-friction, knotless closure system with self-storage of excess lace.

For instance, referring now collectively to FIGS. 1-8, first lace fixation assembly 100 and first lace fixation system 102 are shown in accordance with the present disclosure. In general, first assembly 100 includes first plate 104, second plate 106, tensioning component 108, and fastener 110. FIG. 1 for example illustrates these respective components of first assembly 100 in an assembled configuration. First system 102 includes first assembly 100, guide members 112, and tension member 114. FIG. 8A for example shows these respective components of first system 102 in an assembled configuration. In the example embodiment, tension member 114 is laced through first plate 104 of first assembly 100 via arcuate slots 116 that guide ends of tension member 114 from entry apertures 118 to exit aperture 120. FIG. 2 for example illustrates entry apertures 118 and exit aperture 120, and FIG. 3 for example illustrates arcuate slots 116. Tension member 114 is further laced through guide members 112 via opposing grooves 122 so that tension member 114 does not overlap onto itself when laced thereto. Both first assembly 100, at least in part, and guide members 112 are coupled to front panel 124 of boot 126, and tensioning end 128 of tension member 114 is coupled to tensioning component 108 at notch 130 of tensioning component 108. FIGS. 8A-B for example illustrate coupling of first assembly 100 and guide members 112 to boot 126 as well as tension member 114 to tensioning component 108.

In practice, tightening of boot 126 is performed or perfected by application of pulling force to tensioning component 108, forcing first side panel 132 and second side panel 134 of boot 126 together. While maintaining pulling force, tensioning component 108 is used to wrap tension member 114 into channel or groove 136 that is formed between first plate 104 and second plate 106. FIG. 5 for example illustrates groove 136 formed between first plate 104 and second plate 106. Here, initial wrapping of tension member 114 into groove 136 forces tension member 114 into friction gap 138 that has surfaces along the length of which imparts force on tension member 114 when positioned thereto so that tension is generally maintained on tension member 114 when pulling force is removed, as discussed further below. Further wrapping of tension member 114 into groove 136 forces portions of tension member 114 into storage gap 140. Storage gap 140 within groove 136 is therefore generally wider than friction gap 138 as storage gap 140 serves a different purpose than friction gap 138 in that it is used to store excess length of tension member 114. Tension member 114 as wrapped onto itself though within both friction gap 138 and storage gap 140 imparts force on itself when positioned thereto, so that tension is generally maintained on tension member 114 when pulling force is removed.

Wrapping of tension member 114 into groove 136 proceeds until length of tension member 114 protruding from exit aperture 120 is substantially wound into groove 136. Tensioning component 108 is then generally snap-coupled onto first assembly 100 at groove 136. Tensioning component 108 may be decoupled from first assembly 100 by application of leverage similar to that applied when opening a bottle having a cap, and may be used to unwind tension member 114 thereby loosening first side panel 132 and second side panel 134 of boot 126. First side panel 132 and/or second side panel 134 may then be opened to allow exit, or tension reapplied to tension member 114 as desired. Such an implementation may be beneficial or advantageous in many respects. For example, knotting of tension member 114 is not required, excess length of tension member 114 is stored to first assembly 100 without additional steps, and through the use of tensioning component 108, there is no need for a user to physically touch tension member 114. Still other benefits and/or advantages are possible as well.

Referring now specifically to FIGS. 1-6, first lace fixation assembly 100 is shown in accordance with the present disclosure. As mentioned above, first assembly 100 includes first plate 104, second plate 106, tensioning component 108, and fastener 110. When assembled, axle- or post-like keyed portion 142 formed on protrusion 144 of first plate 104, as shown for example in FIG. 2, is positioned to complementary recess 146 of second plate 106, as shown for example in FIG. 4. Additionally, fastener 110 is positioned to both second plate aperture 148 that is adjacent to recess 146 and first plate aperture 150 that is formed within keyed portion 142 to secure first plate 104 with second plate 106. In the example embodiment, keyed portion 142 and recess 146 are star-shaped in cross-section. Other embodiments are however possible, and shape of keyed portion 142 and recess 146 may be implementation-specific. Further, as mentioned above, tensioning component 108 is generally snap-fit coupleable to groove 136 that is formed between first plate 104 and second plate 106. Rotational movement of tensioning component 108 is limited or restricted when positioned to groove 136 by interlock of bumps or ridges 152 formed on both second plate 106 and tensioning component 108, illustrated for example at FIG. 4 and at FIG. 6.

Friction gap 138 within groove 136 is defined by first ridged flutes 154 that extend in a spoke pattern from keyed portion 142 of first plate 104, and second ridged flutes 156 that extend in the spoke pattern from recess 146 of second plate 106. FIG. 2 for example illustrates first ridged flutes 154, and FIG. 4 for example illustrates second ridged flutes 156. It is contemplated that more or fewer ridged flutes may be utilized in any pattern as desired, and further number and shape of first ridged flutes 154 and second ridged flutes 156 may be implementation-specific. In the example embodiment, when first plate 104 is coupled with second plate 106, first ridged flutes 154 and second ridged flutes 156 are rotationally offset from each other so as to form a path for tension member 114 similar to that formed by an interdigitated comb structure. In this instance, however, fingers of the comb structure are interdigitally arranged along a circle. In this manner, first ridged flutes 154 and second ridged flutes 156 are configured and arranged to impart force on tension member 114 when tension member 114 is positioned to friction gap 138 within groove 136, so that tension is generally maintained on tension member 114 when pulling force is removed.

Referring now specifically to FIGS. 7A-C, a particular one of guide members 112 is shown in accordance with the present disclosure. As mentioned above, tension member 114 is laced through guide members 112 via opposing grooves 122 so that tension member 114 does not overlap onto itself. In general, grooves 122 positioned on each side of mounting aperture 158 provide a curved low-friction pathway for tension member 114 as it interfaces with panels 124, 132, and 134 of boot 126, similar to arcuate slots 116 of first plate 104 that provide a low-friction pathway for tension member 114 from entry apertures 118 to exit aperture 120. Whereas a typical lacing pattern may route laces back and forth between opposing panels, with laces crossing each other at various points along the center line of a particular panel, guide members 112 eliminate lace crossing and resulting friction that which may impede closure. It is contemplated that any number of guide members 112 may be employed to realize desired closure characteristics while maintaining the lowest possible lace system friction.

In the present example, with guide members 112 attached to center portion of front panel 124, tension member 114 is guided from first side panel 132 through a particular one of guide members 112, and back to first side panel 132. Similarly, tension member 114 is guided from second side panel 134 through a particular one of guide members 112, and back to second side panel 134. Tension member 114 thus does not overlap onto itself and does not bind, chafe, or create excess friction. It is contemplated that body 160 of guide members 112 may be curved to generally match the shape of front panel 124 or other intermediate panel onto which they are coupled. Further, profile or thickness 162 of guide members 112 may be defined such that tension member 114 is raised above a surface of an intermediate panel to further reduce friction. Various methods may be employed to attach guide members 112 to front panel 124, such as in a manner that allows guide members 112 to self-align under loads presented by tension member 114. Further, in order to facilitate injection molding with minimal tooling complexity, in one embodiment the bearing surface of the guide members 112 may be formed by alternating grooves in top and bottom surfaces. This arrangement may sufficiently capture tension member 114, keeping tension member 114 bearing upon the desired radius surface, while not requiring any sliding elements in the injection mold.

Referring now to FIG. 9, another lace fixation system 902 is shown in accordance with the present disclosure. System 902 is similar to first lace fixation system 102 as described above in many respects. For example, system 902 includes first lace fixation assembly 100 of at least FIG. 1 coupled to front panel 904 of boot 906. In the example embodiment, however, tension member 908 is laced through guide members 910 so as to overlap or cross itself. Guide members 910 in FIG. 9 are webbing or fabric strips that are sewn or otherwise coupled to panels of the article. The webbing or fabric strips 910 include loops through which the tension member 908 is inserted. The webbing or fabric strips 910 may be angled or directed to guide the tension member 908 about the article as desired. In practice though, tightening of boot 906 using first assembly 100 may be performed in a manner similar to that described above. Further, FIG. 9 demonstrates flexibility of first assembly 100 in that tensioning component 108 may be coupled to groove 136 (e.g., see FIG. 5) that is formed between first plate 104 and second plate 106 without orientation-specific keying. In other words, tensioning component 108 may be coupled to groove 136 in any particular orientation. For example, FIG. 8C illustrates tensioning component 108 positioned to groove 136 so that notch 130 is orientated towards guide members 112. In contrast, FIG. 9 illustrates tensioning component 108 positioned to groove 136 so that notch 130 is orientated away from guide members 910.

Referring now to FIGS. 10A-16B, second lace fixation assembly 1000 and second lace fixation system 1002 are shown in accordance with the present disclosure. In general, second assembly 1000 includes plate 1004 and tensioning component 1006. FIG. 10B for example illustrates these respective components of second assembly 1000 in an assembled configuration. Second system 1002 includes second assembly 1000, guide members 1008, and tension member 1010. FIG. 15 for example illustrates these respective components of second system 1002 in an assembled configuration. In the example embodiment, tension member 1010 is laced through plate 1004 of second assembly 1000 via plate apertures 1011 that guide tension member 1010 through plate 1004, and further is laced through guide members 1008 so that tension member 1010 overlaps onto itself. FIG. 12C for example illustrates plate apertures 1011, and FIG. 15 and FIG. 16A for example illustrate lacing of tension member 1010 through guide members 1008 that are coupled to boot 1014, and lacing of tension member 1010 through plate 1004, respectively. Other embodiments though are possible. For example, it is contemplated that guide members 112 as discussed above may be used in place of guide members 1008.

Both second assembly 1000, at least in part, and guide members 1008 are coupled to front panel 1012 of boot 1014, and tensioning end 1016 of tension member 1010 is coupled to tensioning component 1006 at component apertures 1018. FIGS. 11A-B for example illustrate component apertures 1018 of tensioning component 1006, and FIG. 16A for example illustrates tensioning end 1016 of tension member 1010 coupled to tensioning component 1006. In the example embodiment, component apertures 1018 flare open into elongated slots on bottom side 1005 of tensioning component 1006 to gently guide tension member 1010 there-through, and plate 1004 includes primary surface 1007 that may be curved to at least partially conform to shape of panel 1012 of boot 1014, similar to first plate 104 of first assembly 100 shown at least in FIG. 1.

In practice, tightening of boot 1014 is performed or perfected by application of pulling force to tensioning

component **1006**, forcing first side panel **1020** and second side panel **1022** of boot **1014** together. While maintaining pulling force, tensioning component **1006** is used to wrap tension member **1010** into channel or groove **1024** formed by plate **1004**. FIG. **10B** for example illustrates groove **1024** formed by plate **1004**. Wrapping of tension member **1010** tightly onto itself within groove **1024** fixes tension member **1010** in place, so that tension is generally maintained on tension member **1010** when pulling force is removed. Wrapping of tension member **1010** into groove **1024** proceeds until length of tension member **1010** protruding from component apertures **1018** is substantially wrapped into groove **1024**. Tensioning component **1006** is then snap-coupled onto flange **1026** of plate **1004** so that locking surface **1028** of at least one flexible tab **1030** of tensioning component **1006** engages with locking surface **1032** of flange **1026** adjacent to groove **1024**. FIG. **14** in a particular instance illustrates tensioning component **1006** snap-coupled onto flange **1026** of plate **1004**. In the example embodiment, tensioning component **1006** may subsequently be decoupled from plate **1004** by application of leverage to tensioning component **1006** similar to that of opening certain types of aspirin containers for example, and may be used to unwind tension member **1010**, thereby releasing force imparted on first side panel **1020** and second side panel **1022** of boot **1014**. First side panels **1020** and/or second side panel **1022** may then be opened to allow exit, or tension reapplied to tension member **1010** as desired. Such an implementation may be beneficial or advantageous in many respects, including at least those discussed above in connection with first assembly **100**.

Further, referring now specifically to FIGS. **16A-B**, flexibility of second assembly **1000** is demonstrated in that tension member **1010** may be laced through plate **1004** of second assembly **1000** in a particular direction as desired. For example, FIG. **16A** illustrates tension member **1010** laced through plate **1004** of second assembly **1000** in a direction extending away from front end of shoe **1014**, so that tightening of shoe **1014** is perfected by application of pulling force generally in direction A. In contrast, FIG. **16B** illustrates tension member **1010** laced through plate **1004** of second assembly **1000** in a direction extending towards front end of boot **1014**, so that tightening of boot is perfected by application of pulling force generally in direction B.

Referring now specifically to FIGS. **11-14**, second lace fixation assembly **1000** is shown in accordance with the present disclosure. FIGS. **12A-C** in particular show second assembly **1000** in varying dimension, generally increasing in size from FIG. **12A** proceeding in order to FIG. **12C**. As mentioned above, second assembly **1000** includes plate **1004** and tensioning component **1006**. When assembled, keyed aperture **1034** formed within flange **1026** of plate **1004** is positioned to complementary post **1036** of tensioning component **1006**. FIG. **11A** and FIG. **11B** for example illustrate keyed aperture **1034** formed within flange **1026** of plate **1004**, and post **1036** of tensioning component **1006**. In the example embodiment, keyed aperture **1034** and post **1036** are peripherally notched. Other embodiments are however possible. Tensioning component **1006** is snap-fit coupleable to keyed aperture **1034** formed within flange **1026** of plate **1004** by at least one flexible tab **1030** of tensioning component **1006** that has locking surface **1028** that engages with locking surface **1032** of flange **1026** adjacent groove **1024**. FIG. **14** for example illustrates flexible tab **1030** of tensioning component **1006** that has locking surface **1028** that engages with locking surface **1032** of flange **1026** adjacent to groove **1024**. In the example embodiment, rotational movement of tensioning component

1006 when coupled to plate **1004** is limited or restricted because post **1036** is rigidly fixed to plate **1004** at mounting surface **1038**.

Referring now to FIG. **17**, still another lace fixation system **1702** is shown in accordance with the present disclosure. System **1702** is similar to second lace fixation system **1002** as described above in many aspects. For example, system **1702** includes second lace fixation assembly **1000** of at least FIG. **10** coupled to panel **1704** of item **1706**. In this example, however, second assembly **1000** is not coupled to a central panel of item **1706**, and further tension member **1708** is alternately laced through guide members **1710** terminating at end **1712**. In practice though, tightening of item **1706** using second assembly **1000** may be performed in a manner similar to that described above. Further, FIG. **17** demonstrates flexibility of second assembly **1000** in that second assembly **1000** may generally be coupled to a particular item at any location as desired, such as to an eyestay of a shoe as illustrated in FIG. **17**. Termination at end **1712** as shown in FIG. **17** may increase the tension imparted to tension member **1708** as the system is used to close item **1706**. Still other lace fixation systems embodiments are possible.

For example, referring now to FIG. **18**, still another lace fixation system **1802** is shown in accordance with the present disclosure. System **1802** is similar to second lace fixation system **1002** as described above in many aspects. For example, system **1802** includes first instance **1000a** of second lace fixation assembly **1000** of at least FIG. **10** coupled to first panel **1804** of item **1806**. In this example, however, system **1802** further includes second instance **1000b** of second lace fixation assembly **1000** coupled to second panel **1808** of item **1804**, and tension member **1810** is coupled to fixed guide **1812** positioned to central panel **1814** of item **1806**. In some embodiments, first instance **1000a** of second assembly **1000** and second instance **1000b** of second assembly **1000** may be sized differently, for example as illustrated in FIG. **12**. Such an implementation as shown in FIG. **18** may be an example of a zone or zonal tightening system, whereby tension imparted on first length **1816** of tension member **1808** may be controlled by first instance **1000a** of second assembly **1000**, and tension imparted on second length **1818** of tension member **1808** may be controlled by second instance **1000b** of second assembly **1000**. Tension member **1810** may be fixedly coupled with fixed guide **1812** (i.e., the tension member **1810** may be prevented from sliding through guide **1812**) to allow zonal tensioning of a proximal and distal portion of item **1806**. Still other lace fixation system embodiments are possible.

For example, referring now to FIGS. **19A-E**, still another lace fixation system **1902** is shown in accordance with the present disclosure. System **1902** is similar to second lace fixation system **1002** as described above in many aspects. For example, system **1902** includes embodiment **1000a** of second lace fixation assembly **1000** of at least FIG. **10** coupled to panel **1904** of item **1906**. In this example, however, system **1902** includes tension member **1908** coupled to fixed guide **1910** positioned to central panel **1912** of item **1906**. As shown in the sequence of FIGS. **19A-E**, tension member **1908** may be positioned to guide members **1914** and fixed guide **1910** so that tension member **1908** may be wrapped and coupled to embodiment **1000a** of second assembly **1000** in a manner such as described above. In particular, tension member **1908** may be initially laced to guide member **1914a** and guide member **1914b** positioned in a lower portion of the item, and then laced through fixed

guide 1910 as shown in FIG. 19C, such as by inserting tension member 1908 through a lumen of fixed guide 1910. Tensioning component 1006 may then be pulled in direction X to apply tension to first length 1916 of tension member 1908, thereby pulling the lower portion of side panel 1918 and side panel 1920 together. Tension member 1908 may then be wrapped around a post of fixed guide 1910 to lock or maintain a tension of first length 1916 of tension member 1908 and thereby secure the lower portion in a tightened arrangement. Tension member 1908 may then be laced to guide member 1914c and guide member 1914d in an upper portion of the item. Tensioning component 1006 may then be pulled in direction Y to apply tension to second length 1922 of tension member 1908, thereby pulling the upper portion of side panel 1918 and side panel 1920 together. Tension member 1908 may then be wrapped into channel or groove 1024 formed by plate 1004 to lock or maintain a tension of second length 1922 of tension member 1908 and thereby secure the upper portion in a tightened arrangement. Such an implementation as shown in FIGS. 19A-E may be an example of a zone or zonal tightening system, whereby tension imparted on first length 1916 of tension member 1908 may be controlled or maintained due to coupling of tension member 1908 to fixed guide 1910, and tension imparted on second length 1922 of tension member 1908 may be controlled or maintained due to coupling of tension member 1908 to plate 1004. Still many other lace fixation system embodiments are possible.

Referring now to FIG. 20, still another lace fixation system 2002 is shown in accordance with the present disclosure. System 2002 is similar to both first lace fixation system 102 and second lace fixation system 1002 as described above in many respects. For example, system 2002 includes first lace fixation assembly 100 of at least FIG. 1 coupled to first panel 2004 of item 2006, and also includes second lace fixation assembly 1000 of at least FIG. 10 coupled to second panel 2008 of item 2006. In this example, however, system 2002 includes first tension member 2010 coupled to first assembly 100 in a manner similar to that described above, and also includes second tension member 2012 coupled to second assembly 1000 in a manner similar to that described above. Here, second tension member 2012 is shown partially in phantom line as a portion of second tension member 2012 is routed generally underneath outer shell 2014 of item 2006, such as through tubing positioned under the upper of a boot. Such an implementation may be another example of a zone or zonal tightening system, whereby tension imparted on first tension member 2010 may be controlled by first assembly 100, and tension imparted on second tension member 2012 may be controlled by second assembly 1000. In the illustrated embodiment, first tension member 2010 and first assembly 100 is used to tighten an upper portion of a boot while second tension member 2012 and second lace fixation assembly 1000 is used to tighten a lower portion of a boot. Still other lace fixation system embodiments are possible.

Referring now to FIG. 21, still another lace fixation system 2102 is shown in accordance with the present disclosure. System 2102 is similar to second lace fixation system 1002 as described above in many respects. For example, system 2102 includes second lace fixation assembly 1000 of at least FIG. 10 coupled to panel 2104 of item 2006. In this example, however, second assembly 1000 is not coupled to a central or offset panel of item 2106, and instead is coupled to rear portion 2108 of item 2106, such as heel portion of a shoe. Further, tension member 2110 is laced to second assembly 1000 at a point furthest possible from

guide members 2112 of item 2106, such as by being routed through tubing coupled with and/or positioned under an upper material layer of the shoe. In practice though, tightening of item 2106 using second assembly 1000 may be performed in a manner similar to that described above. Further, FIG. 21 demonstrates flexibility of second assembly 1000 in that second assembly 1000 may generally be coupled to a particular item at any location as desired. Still other lace fixation system embodiments are possible.

Referring now to FIG. 22, still another lace fixation system 2202 is shown in accordance with the present disclosure. System 2202 is similar to lace fixation system 2002 of FIG. 20 as described above in many respects. In this example, however, system 2202 exhibits an alternate embodiment of first lace fixation assembly 100. In particular, lace fixation assembly 2204 coupled to first panel 2206 of item 2208 includes reel assembly mechanism 2210 having a knob or dial component 2212 that is rotatable in a first direction (e.g., clockwise) to wind the tension member 2216 about a channel or groove of a spool (not shown) positioned under the knob 2212 and within a housing 2214 of the reel assembly mechanism 2210. The tension member 2216 is laced and/or positioned around one or more guides of an upper portion of item 2208 (i.e., boot). The reel assembly mechanism 2210 is used to tighten the upper portion of item 2208 by tensioning the tension member 2216 via reel assembly mechanism 2210. In some embodiments, the reel assembly mechanism 2210 may be rotated in a second direction (i.e., counter-clockwise) to loosen the tension in tension member 2216 and thereby loosen the upper portion of item 2208. In other embodiments, the knob 2212 may be grasped and moved axially upward to disengage internal components of reel assembly mechanism 2210 and thereby release the tension on tension member 2216. Second assembly 1000 may be used to tension a lower portion of item 2208 as described in the embodiment of FIG. 20. Still other lace fixation assembly embodiments are possible.

For example, referring now to FIGS. 23A-C, third lace fixation assembly 2300 is shown in accordance with the present disclosure. In the example embodiment, tension member 2302 is laced through plate 2304 of third assembly 2300 via lumen or passage 2306 that guides tension member 2302 through plate 2304, and tensioning end 2308 of tension member 2302 is coupled to tensioning component 2310 at component apertures 2312. As shown in particular by the sequence of FIG. 23C, tensioning component 2310 may initially be pulled in direction C so that tension member 2302 in turn is pulled through passage 2306. Tensioning component 2310 may then be flipped or positioned back over plate 2304 whereby portions of tension member 2302 are engaged with ridged friction surfaces 2314 within channel 2316 of plate 2304. The ridged friction surfaces 2314 engage with tension member 2302 to lock or otherwise maintain the tension member 2302 in a tensioned state.

FIG. 23A and FIG. 23B too for example illustrates portions of tension member 2302 engaged with ridged friction surfaces 2314 within channel 2316 of plate 2304. Tensioning component 2310 may then be pulled in direction D that is generally opposite direction C so that slack of tension member 2302 is taken up and portions of tension member 2302 are fully engaged with ridged friction surfaces 2314 within channel 2316 to lock or otherwise maintain the tension member 2302 in the tensioned state. Tensioning component 2310 may then be used to wrap tension member 2302 within second channel 2318 of plate 2304 in rotational direction E and then snap-coupled to flange 2138 of plate 2304 in a manner similar to that described above in con-

nection with tensioning component **1006**. Second channel **2318** may be separated from channel **2316** via a flange or other partition member. In the example embodiment, plate **2304** and tensioning component **2310** of at least FIG. **23** are configured in a manner substantially similar to plate **1004** tensioning component **1006** of at least FIG. **10A-D**, with at least the exception of ridged friction surfaces **2314**. Still other lace fixation assembly embodiments are possible.

Referring now to FIGS. **24A-B**, fourth lace fixation assembly **2400** is shown in accordance with the present disclosure. In the example embodiment, fourth assembly **2400** is substantially similar to second lace fixation assembly **1002** as described above. Fourth assembly **2400** though is configured to exhibit coiler functionality. As shown in particular by the sequence of FIG. **24B**, tensioning component **1006** may initially be pulled in direction **F** so that tension member **1010** in turn is pulled through plate **1004**. Post **2402** of plate **1004** may then be rotated in direction **G** to pull and wind tension member **1010** to groove **1024** formed by plate **1004** (e.g., see FIG. **10**). Tensioning component **1006** may then be snap-coupled onto flange **1026** of plate **1004** in manner as described above. In the example embodiment, post **2402** of plate **1004** may be configured and arranged as a rotary dial having a clock spring or spiral-wound torsion spring so that tension member **1010** may be automatically wound to groove **1024** formed by plate **1004** without a user having to use tensioning component **1006** to wrap tension member **1010** to groove **1024** as describe above. In this manner, the user may simply pull tensioning component **1006** in direction **F** and then release tensioning component **1006** or gently guide tensioning component **1006** as post **2402** automatically rotates in direction **G** to wind tension member **1010** about groove **1024**. In other embodiments, the user may rotate post **2402** in direction **G** to wind the tension member **1010** about groove **1024**. In some embodiments, post **2402** may further be configured and arranged to exhibit push-to-lock/pull-to-unlock functionality whereby when tension member **1010** is fully wrapped to groove **1024** tensioning component **1006** may be pressed to lock second assembly **1002**. A reverse operation may be performed to unlock second assembly **1002** so that tension member **1010** may be unwound from groove **1024**. Still other lace fixation assembly embodiments are possible.

Referring now to FIG. **25**, fifth lace fixation assembly **2500** is shown in accordance with the present disclosure. In the example embodiment, fifth lace fixation assembly **2500** is substantially similar to second lace fixation assembly **1002** as described above. Fifth assembly **2500** though is configured to exhibit incremental tightening/loosening functionality. For example, as shown in particular by the sequence of FIG. **25**, tensioning component **1006** may initially be pulled in direction **H** so that tension member **1010** in turn is pulled through plate **1004**. Tensioning component **1006** may then be used to wrap tension member **1010** to groove **1024** and then snap-coupled onto flange **1026** of plate **1004** in manner as described above. Subsequently, a fine tuning operation may be performed to increase or release tension on tension member **1010**. In particular, tensioning component **1006** may be incrementally rotated in a clockwise direction in a fixed ratcheting motion to increase tension on tension member **1010**, or incrementally rotated in a counterclockwise direction in the fixed ratcheting motion to release tension on tension member **1010**. In the example embodiment, post **2402** of plate **1004** (e.g., see FIG. **24**) may be configured and arranged as a ratcheted rotary dial so that tension on tension member

1010 may be increased or decreased as desired, without having to decouple tensioning component **1006** from plate **1004**.

Although the various disclosed lace fixation assemblies and systems are described in the context of a closure system for footwear or other panels desired to be closed toward one another, it will be appreciated that the designs may be optimized for a variety of other uses in which a lace or cord is desired to be removably secured at various tension levels or adjustment lengths. Examples include: a) fixation of high tensile rigging aboard ships, allowing for easy adjustment of a given line with secure fixation, b) orthopedic bracing products, c) garment closures, d) equestrian accessories, e) wakeboard boots, f) kitesurfing line adjustments, g) backpack and luggage closures.

Having described several embodiments, it will be recognized by those of skill in the art that various modifications, alternative constructions, and equivalents may be used without departing from the spirit of the invention. Additionally, a number of well-known processes and elements have not been described in order to avoid unnecessarily obscuring the present invention. Accordingly, the above description should not be taken as limiting the scope of the invention.

As used herein and in the appended claims, the singular forms “a”, “an”, and “the” include plural referents unless the context clearly dictates otherwise. Thus, for example, reference to “a process” includes a plurality of such processes and reference to “the device” includes reference to one or more devices and equivalents thereof known to those skilled in the art, and so forth. Also, the words “comprise,” “comprising,” “include,” “including,” and “includes” when used in this specification and in the following claims are intended to specify the presence of stated features, integers, components, or steps, but they do not preclude the presence or addition of one or more other features, integers, components, steps, acts, or groups.

What is claimed is:

- [1]** A lacing system for tightening an article, comprising:
 - a fixation member coupled to the article, the fixation member having at least one entry aperture and an exit aperture with a lumen extending therebetween, the fixation member also having a spool with a fixation post;
 - a tension member having an intermediate portion slidably disposed within the lumen of the fixation member such that a proximal portion of the tension member is positioned on a proximal side of the fixation member and a distal portion of the tension member is positioned on a distal side of the fixation member and such that a length of the proximal portion and a length of the distal portion is adjustable via sliding of the tension member within the lumen;
 - a plurality of guide members coupled to the article on the proximal side of the fixation member to guide the proximal portion of the tension member along the article to the fixation member;
 - a tensioning portion of the tension member to effect sliding of the tension member within the lumen and thereby tighten the article by adjusting the length of the proximal portion of the tension member, and to maintain a tightness of the article by winding of the tension member about the fixation post, wherein the tensioning portion is securable to the spool of the fixation member, wherein the plurality of guide members direct the tension member along a panel of the article to the at least one entry aperture, and wherein the tension members overlaps itself along the panel; and

15

wherein the tensioning portion is a tensioning component that is snap-fit coupleable about the spool.]

[2. The system of claim 1, wherein the fixation member further includes a flange shaped complementary to the article.]

[3. The system of claim 1, wherein the lumen extending between the entry aperture and the exit apertures includes an arcuate configuration.]

[4. The system of claim 1, wherein the tensioning portion is ring-shaped.]

[5. The system of claim 1, wherein the spool and the tensioning component each comprise a plurality of traction members that when engaged inhibit rotation of the tensioning component when the tensioning component is secured about the spool.]

[6. A lacing system for tightening an article, comprising: a fixation member coupled to the article, the fixation member having an entry aperture, an exit aperture, and a fixation post that is accessible from an exterior of the fixation member;

a tension member having a proximal portion positioned on a proximal side of the fixation member, a distal portion positioned on a distal side of the fixation member, and an intermediate portion slidably disposed within the fixation member, wherein a length of the proximal portion and a length of the distal portion is adjustable via sliding of the tension member within the fixation member;

a plurality of guide members coupled to the article on the proximal side of the fixation member to guide the proximal portion of the tension member along the article;

a tensioning portion of the tension member that effects sliding of the tension member within the fixation member and thereby tightens the article by adjusting the length of the proximal portion of the tension member, and that maintains a tightness of the article by winding of the tension member about the fixation post from the exterior of the fixation member; and

wherein the tensioning portion comprises a component that is snap-fit coupleable about the fixation member.]

[7. The system of claim 6, wherein the tensioning portion is securable to the fixation member.]

[8. The system of claim 6, wherein the tensioning portion is a component that is coupled to the distal portion of the tension member.]

[9. A lacing system for tightening an article, comprising: a fixation member coupled to the article, the fixation member having at least one entry aperture and an exit aperture with a lumen extending therebetween, the fixation member also having a spool with a fixation post, the fixation post being accessible from an exterior of the fixation member;

a tension member having an intermediate portion slidably disposed within the lumen of the fixation member such that a proximal portion of the tension member is positioned on a proximal side of the fixation member and a distal portion of the tension member is positioned on a distal side of the fixation member and such that a length of the proximal portion and a length of the distal portion is adjustable via sliding of the tension member within the lumen;

a plurality of guide members coupled to the article on the proximal side of the fixation member to guide the proximal portion of the tension member along the article to the fixation member;

16

a tensioning portion of the tension member to effect sliding of the tension member within the lumen and thereby tighten the article by adjusting the length of the proximal portion of the tension member, and to maintain a tightness of the article by winding of the tension member about the fixation post from the exterior of the fixation member, wherein the tensioning portion is securable to the spool of the fixation member; and wherein the tensioning portion is a tensioning component that is snap-fit coupleable about the spool.]

[10. The system of claim 9, wherein the fixation member further includes a flange shaped complementary to the article.]

[11. The system of claim 9, wherein the lumen extending between the entry aperture and the exit apertures includes an arcuate configuration.]

[12. The system of claim 9, wherein the plurality of guide members direct the tension member along a panel of the article without overlap to the at least one entry aperture.]

[13. The system of claim 9, wherein the plurality of guide members direct the tension member along a panel of the article to the at least one entry aperture, and wherein the tension members overlaps itself along the panel.]

[14. The system of claim 9, wherein the tensioning portion is ring-shaped.]

[15. The system of claim 9, wherein the spool and the tensioning component each comprise a plurality of traction members that when engaged inhibit rotation of the tensioning component when the tensioning component is secured about the spool.]

16. *A lacing system for tightening an article, the lacing system comprising:*

a housing that is coupleable with the article, the housing having a rotary dial that includes at least one aperture; a tension member that is windable about a groove of the rotary dial to tighten the article and that is unwindable from about the groove of the rotary dial to loosen the article;

a spiral torsion spring that is operably coupled with the rotary dial and that is configured to effect automatic rotation of the rotary dial in a tightening direction to wind the tension member about the groove of the rotary dial;

a tensioning component that is operably coupled with the tension member and that is configured to effect winding of the tension member about the groove of the rotary dial via the spiral torsion spring; and

a plurality of guide members; wherein the tensioning component is snap coupleable and removably attachable to the housing; and wherein the groove is uncovered by an exterior wall; and wherein the plurality of guide members direct the tension member along a lace path of the article to the at least one aperture and wherein the tension members overlaps itself along the lace path.

17. *The lacing system of claim 16, wherein the tensioning component is attached to the tension member and is configured so that the tension member is pulled distally of the housing to effect winding of the tension member about the groove of the rotary dial via the spiral torsion spring, and wherein winding of the tension member about the groove of the rotary dial causes the tensioning component to move toward the housing.*

18. *The lacing system of claim 17, wherein: the plurality of guide members are coupled to the article on a proximal side of the housing and that are config-*

17

ured to guide a proximal portion of the tension member along the lace path of the article to the housing; the housing includes a lumen through which the tension member is slidably positioned; and the lacing system is configured so that pulling the tension member distally of the housing causes the tension member to slide through the lumen of the housing, thereby tightening the article by adjusting a length of the proximal portion of the tension member.

19. The lacing system of claim 17, wherein the tensioning component is attachable to the housing subsequent to winding of the tension member about the groove of the rotary dial via the-spiral torsion spring.

20. The lacing system of claim 16, wherein the lacing system is further configured so that the rotary dial is user rotatable to wind the tension member about the groove of the rotary dial.

21. The lacing system of claim 16, wherein the lacing system is lockable and unlockable to control winding and unwinding of the tension member about the groove of the rotary dial.

22. The lacing system of claim 21, wherein the tensioning component is configured to be pressed to lock the lacing system and thereby control winding and unwinding of the tension member about the groove of the rotary dial.

23. A method of attaching a lacing system to an article, the method comprising:

providing a lacing system comprising:

a housing having a rotary dial that includes at least one aperture;

a tension member that is windable about a groove of the rotary dial to tighten the article and that is unwindable from about the groove of the rotary dial to loosen the article, wherein the groove is uncovered in a radial direction by an exterior wall;

a spiral torsion spring that is operably coupled with the rotary dial and that is configured to effect automatic rotation of the rotary dial in a tightening direction to wind the tension member about the groove of the rotary dial;

a tensioning component that is operably coupled with the tension member and that is configured to effect winding of the tension member about the groove of

18

the rotary dial via the-spiral torsion spring, wherein the tensioning component is snap coupleable and removably attached to the housing; and

a plurality of guide members; and

attaching the lacing system to the article; wherein

wherein the plurality of guide members direct the tension member along a lace path of the article to the at least one aperture and wherein the tension members overlaps itself along the lace path.

24. The method of claim 23, wherein the tensioning component is attached to the tension member and is configured so that the tension member is pulled distally of the housing to effect winding of the tension member about the groove of the rotary dial via the spiral torsion spring, and wherein winding of the tension member about the groove of the rotary dial causes the tensioning component to move toward the housing.

25. The method of claim 24, wherein:

the guide members are coupled to the article on the proximal side of the housing and that are configured to guide a proximal portion of the tension member along the lace path of the article to the housing;

the housing includes a lumen through which the tension member is slidably positioned; and

the lacing system is configured so that pulling the tension member distally of the housing causes the tension member to slide through the lumen of the housing, thereby tightening the article by adjusting a length of the proximal portion of the tension member.

26. The method of claim 23, wherein the lacing system is further configured so that the rotary dial is user rotatable to wind the tension member about the groove of the rotary dial.

27. The method of claim 23, wherein the lacing system is lockable and unlockable to control winding and unwinding of the tension member about the groove of the rotary dial.

28. The method of claim 27, wherein the tensioning component is configured to be pressed to lock the lacing system and thereby control winding and unwinding of the tension member about the groove of the rotary dial.

* * * * *