



US 20190201039A1

(19) **United States**

(12) **Patent Application Publication**
Widenhouse et al.

(10) **Pub. No.: US 2019/0201039 A1**

(43) **Pub. Date: Jul. 4, 2019**

(54) **SITUATIONAL AWARENESS OF ELECTROSURGICAL SYSTEMS**

provisional application No. 62/611,340, filed on Dec. 28, 2017, provisional application No. 62/611,339, filed on Dec. 28, 2017.

(71) Applicant: **Ethicon LLC**, Guaynabo, PR (US)

(72) Inventors: **Tamara Widenhouse**, Clarksville, OH (US); **David C. Yates**, West Chester, OH (US); **Frederick E. Shelton, IV**, Hillsboro, OH (US)

(21) Appl. No.: **16/115,211**

(22) Filed: **Aug. 28, 2018**

Publication Classification

- (51) **Int. Cl.**
A61B 17/32 (2006.01)
A61B 34/30 (2006.01)
A61B 18/12 (2006.01)
A61B 18/14 (2006.01)
- (52) **U.S. Cl.**
 CPC *A61B 17/320092* (2013.01); *A61B 34/30* (2016.02); *A61B 2017/00075* (2013.01); *A61B 18/1445* (2013.01); *A61B 18/1206* (2013.01)

Related U.S. Application Data

(60) Provisional application No. 62/721,995, filed on Aug. 23, 2018, provisional application No. 62/721,998, filed on Aug. 23, 2018, provisional application No. 62/721,999, filed on Aug. 23, 2018, provisional application No. 62/721,994, filed on Aug. 23, 2018, provisional application No. 62/721,996, filed on Aug. 23, 2018, provisional application No. 62/692,747, filed on Jun. 30, 2018, provisional application No. 62/692,748, filed on Jun. 30, 2018, provisional application No. 62/692,768, filed on Jun. 30, 2018, provisional application No. 62/650,898, filed on Mar. 30, 2018, provisional application No. 62/650,887, filed on Mar. 30, 2018, provisional application No. 62/650,882, filed on Mar. 30, 2018, provisional application No. 62/650,877, filed on Mar. 30, 2018, provisional application No. 62/611,341, filed on Dec. 28, 2017,

(57) **ABSTRACT**

A surgical instrument is disclosed. The surgical instrument comprises an end effector comprising an ultrasonic blade and a clamp arm. The clamp arm is movable relative to the ultrasonic blade to transition the end effector through different closure stages between an open configuration and a closed configuration to clamp tissue between the ultrasonic blade and the clamp arm. The surgical instrument further comprises a transducer configured to generate an ultrasonic energy output, a waveguide configured to transmit the ultrasonic energy output to the ultrasonic blade, and a sensor configured to transmit sensor signals indicative of the closure stages of the end effector. The surgical instrument further comprises a control circuit configured to receive the sensor signals and select an operational mode from operational modes delivering different ultrasonic energy outputs from the transducer based on the received sensor signals.

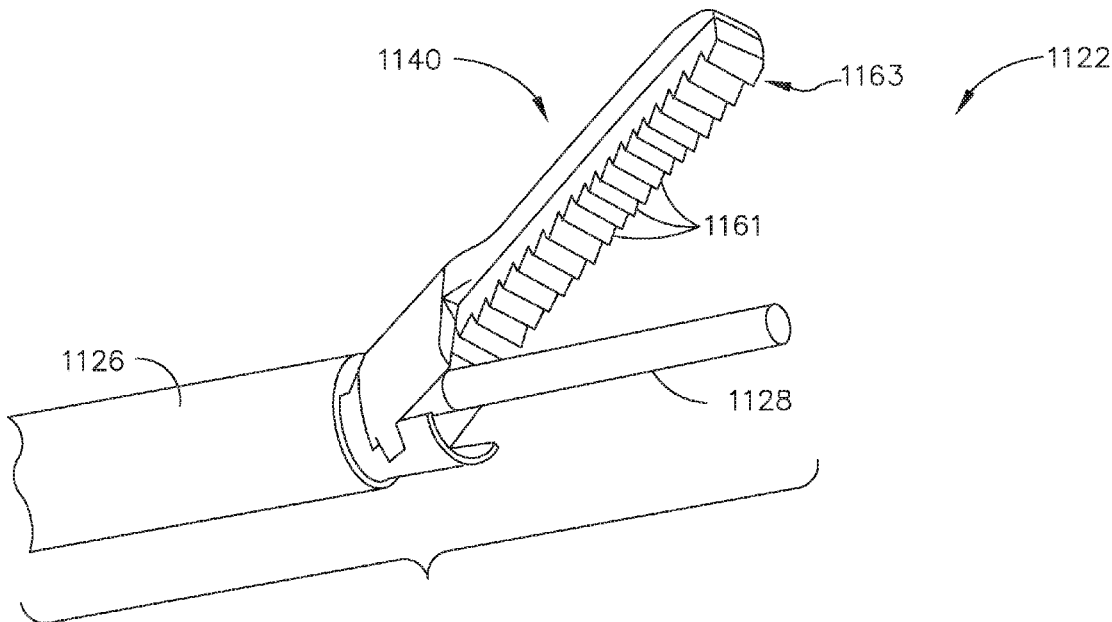

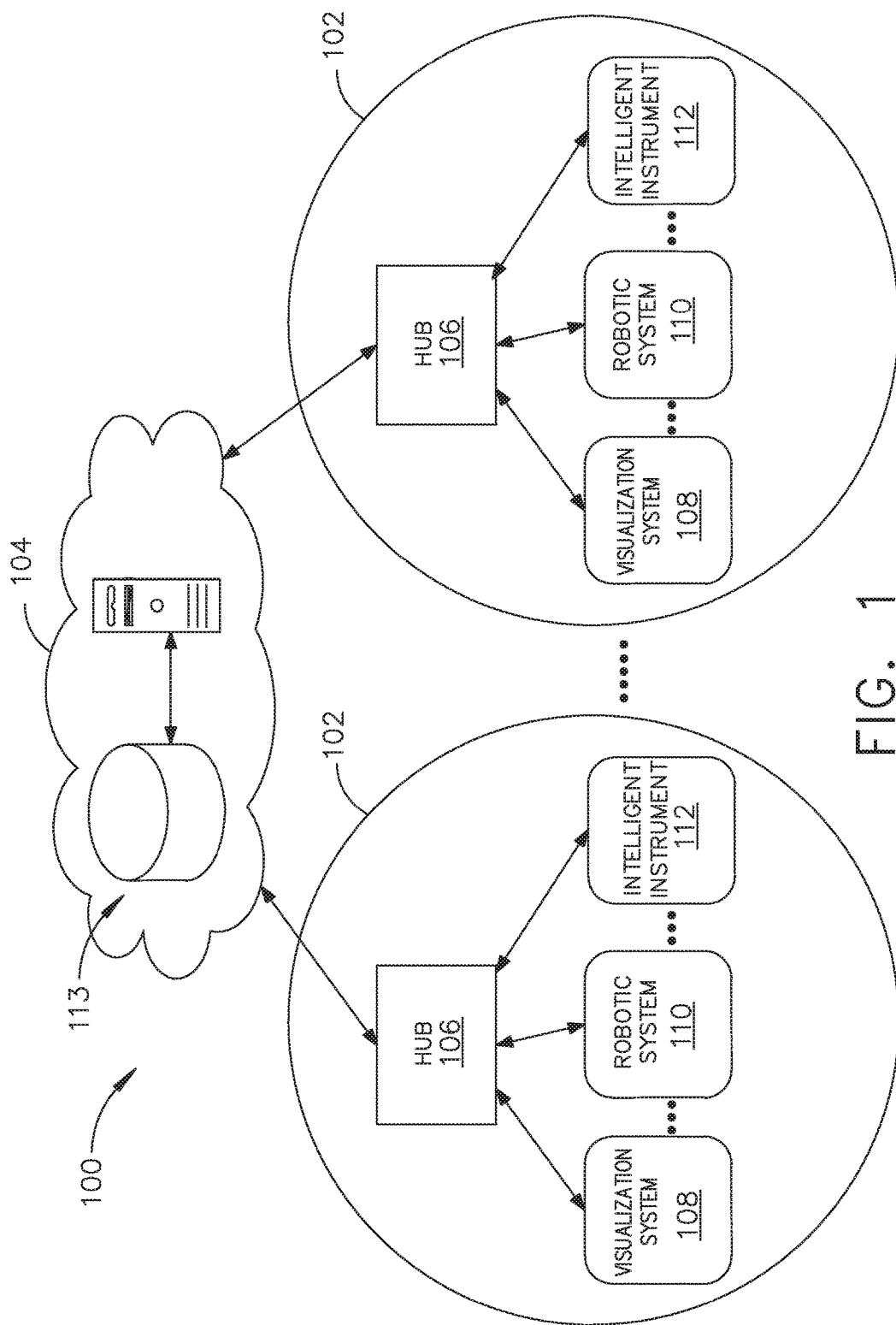

FIG. 1

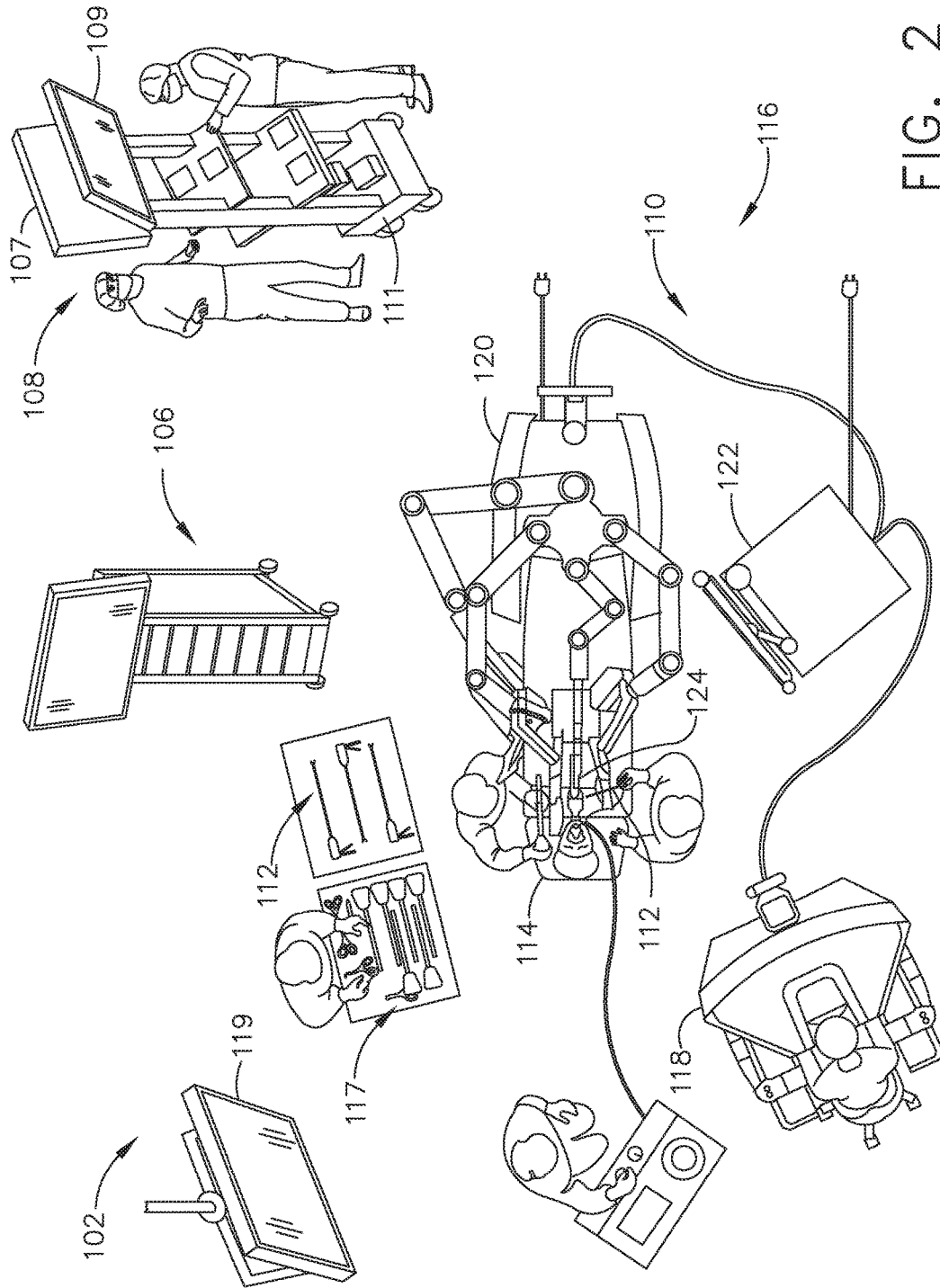

FIG. 2

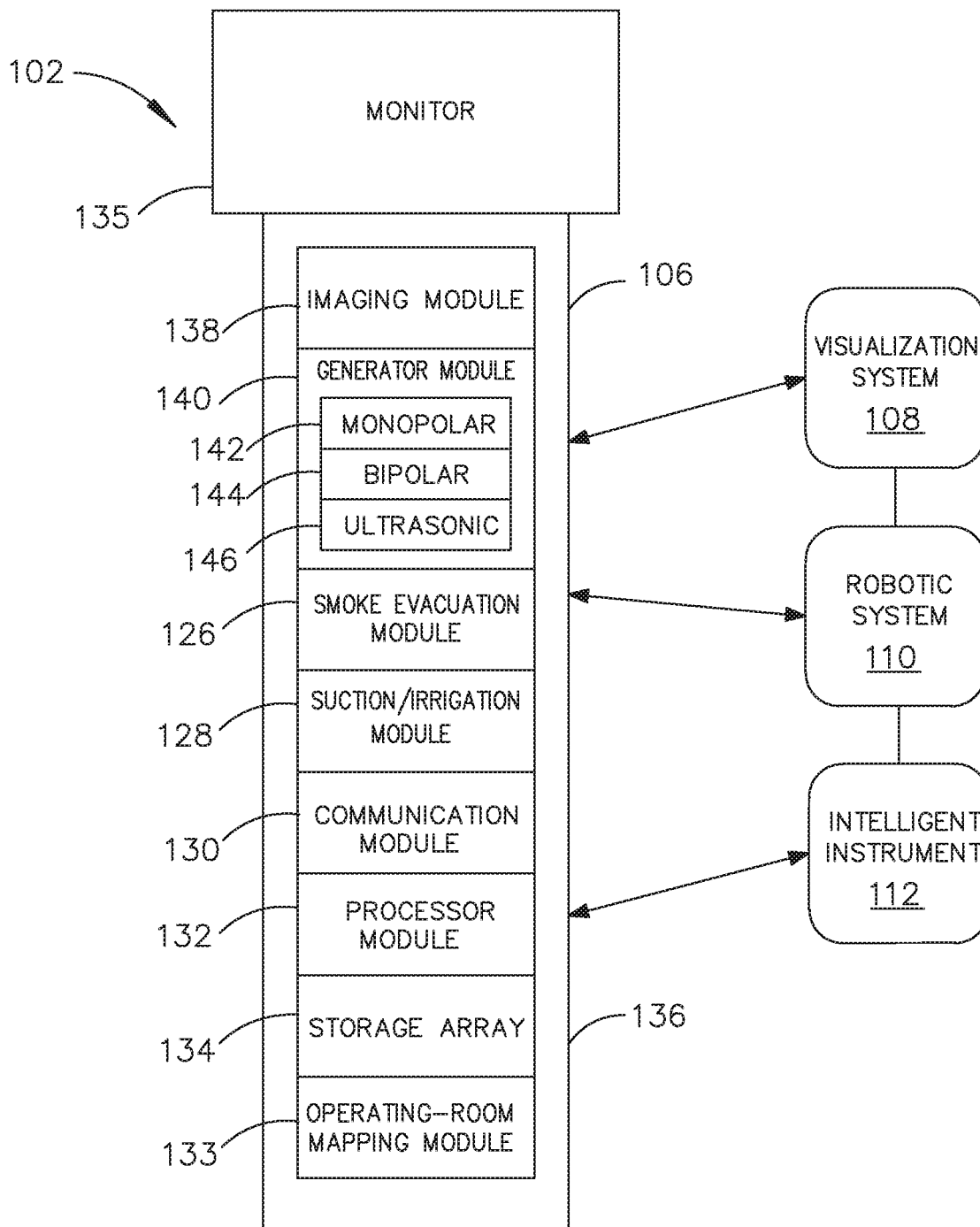

FIG. 3

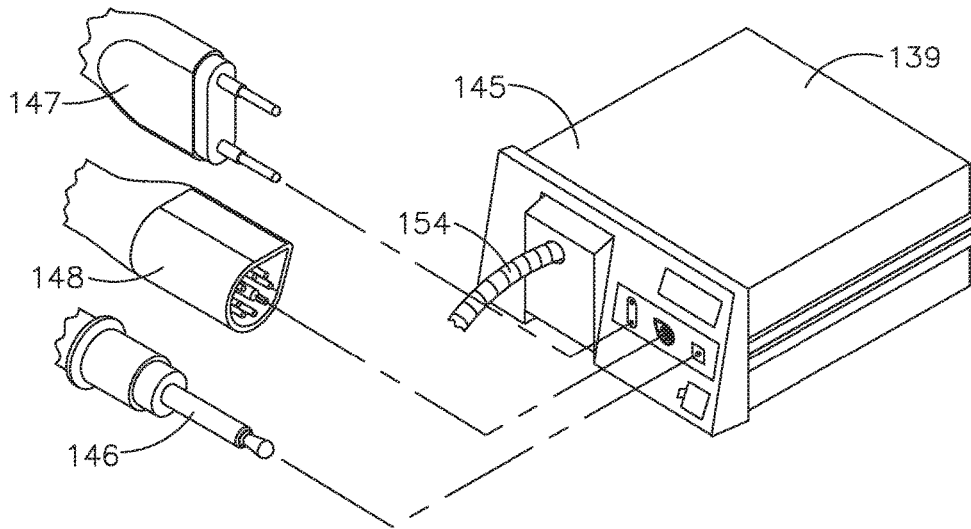

FIG. 5

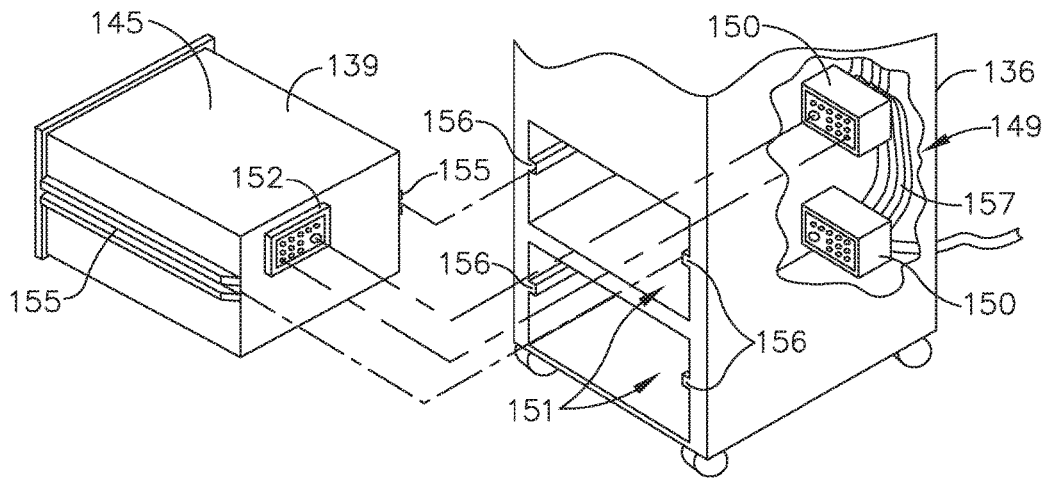

FIG. 4

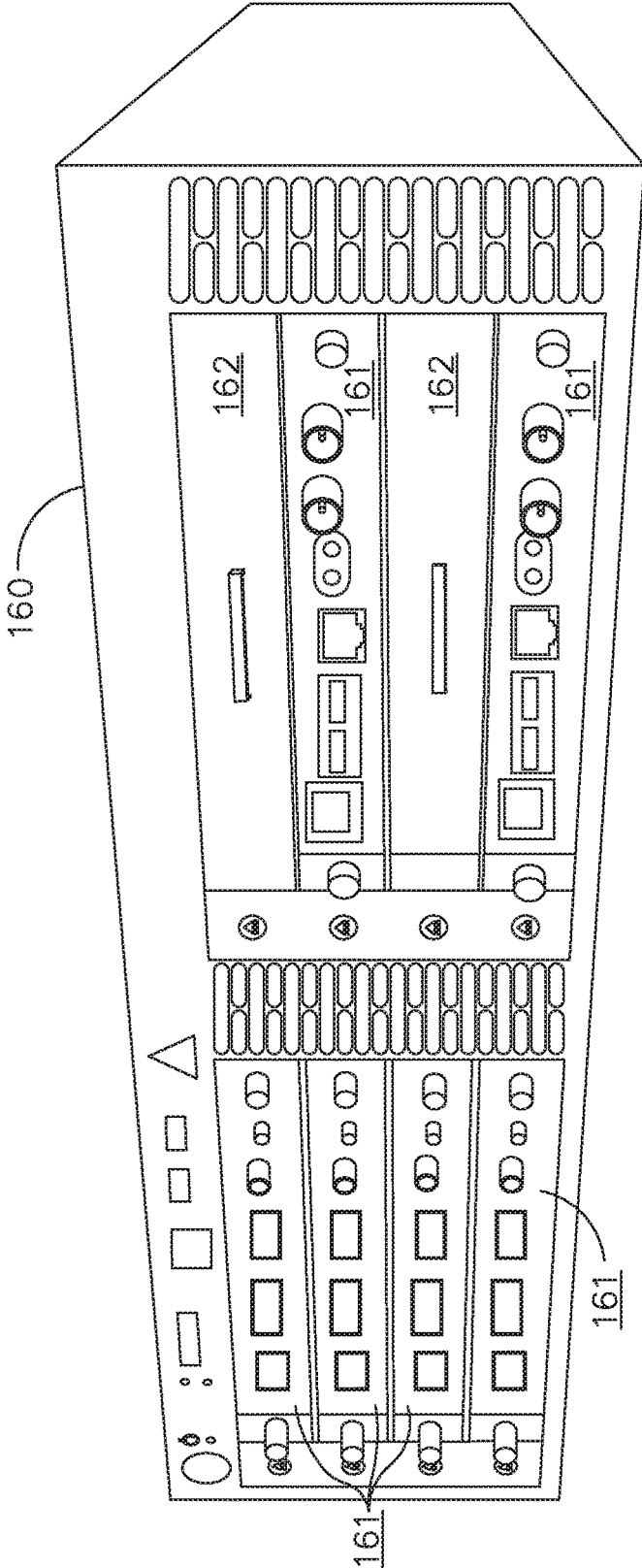

FIG. 6

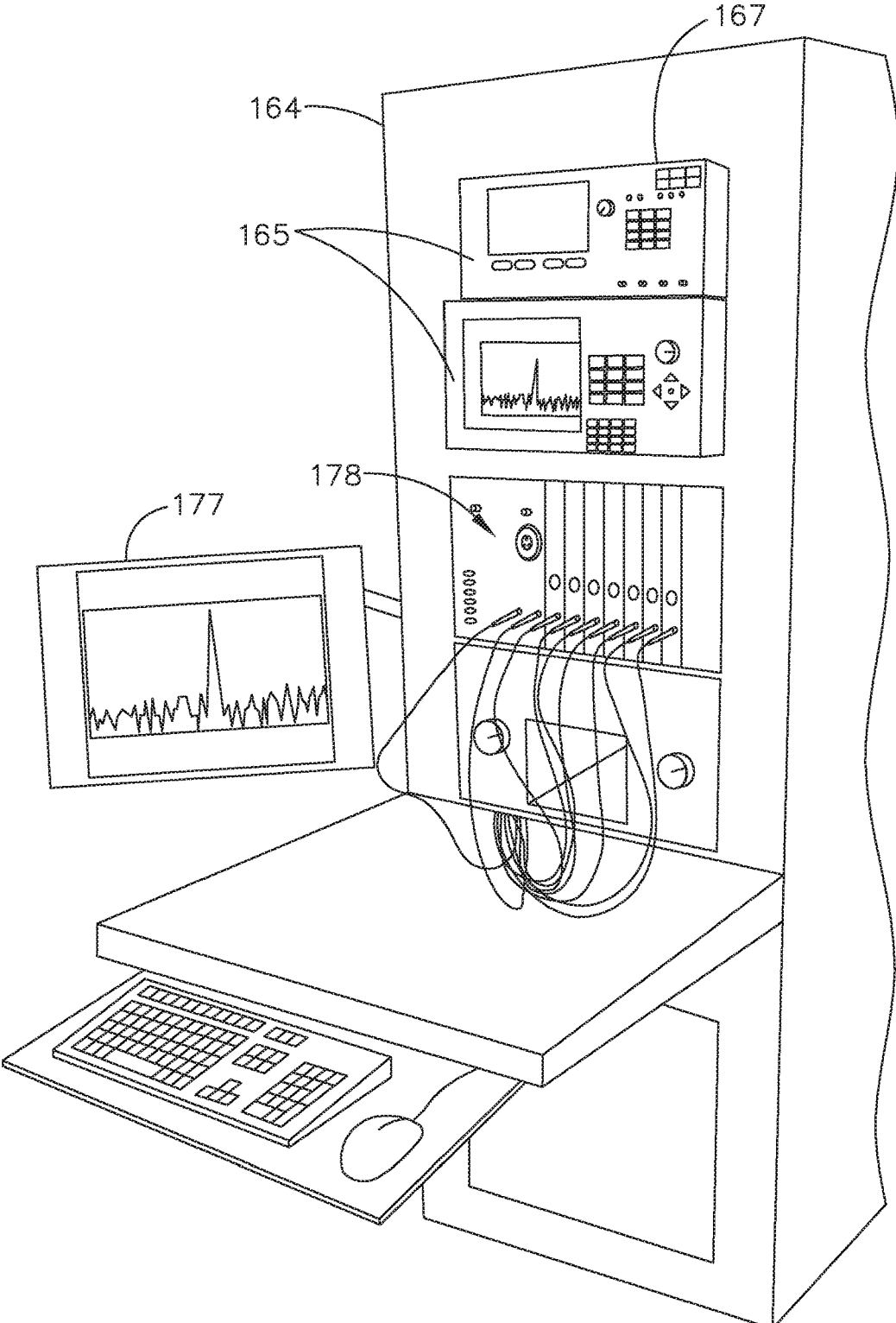

FIG. 7

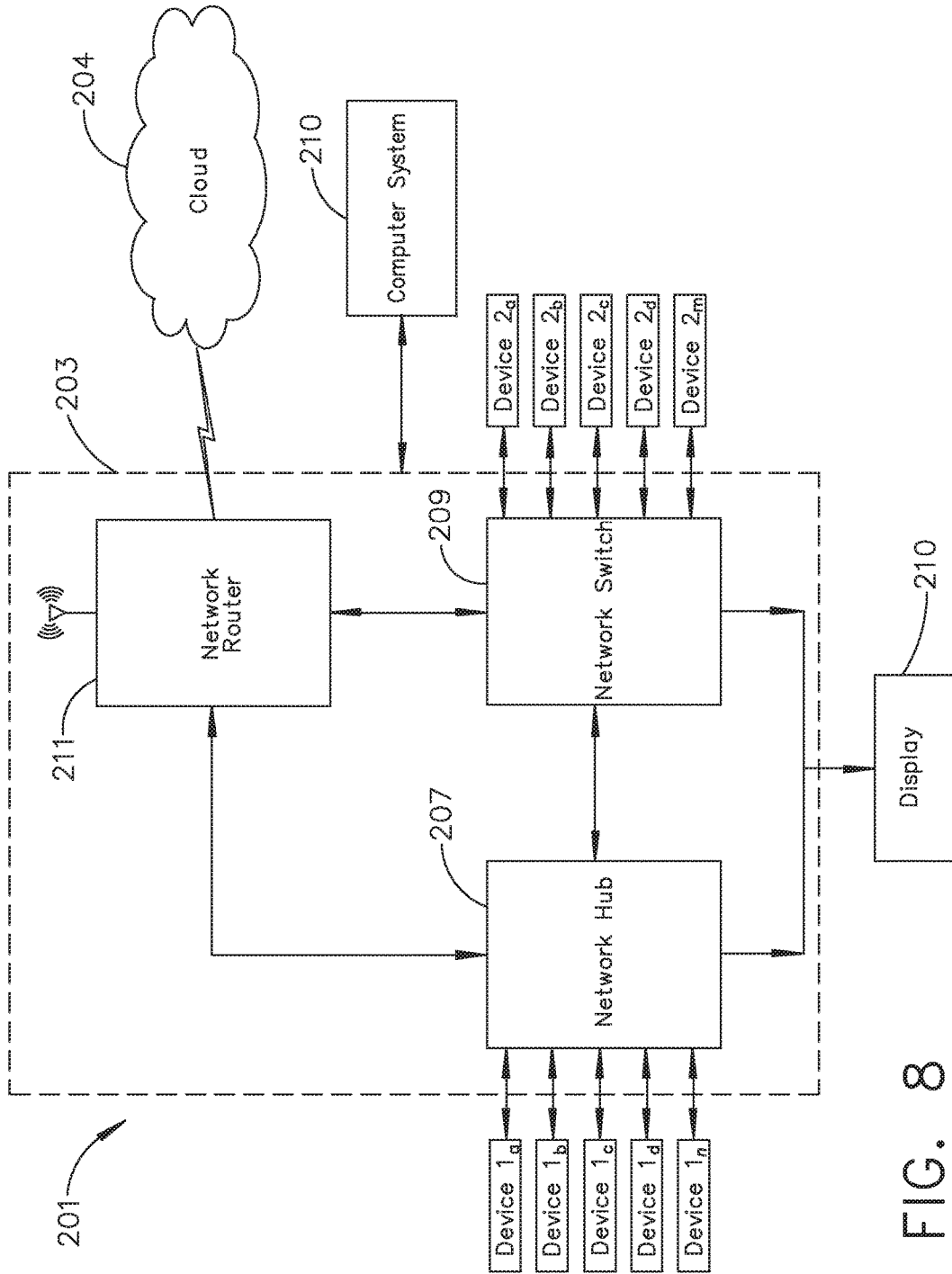

FIG. 8

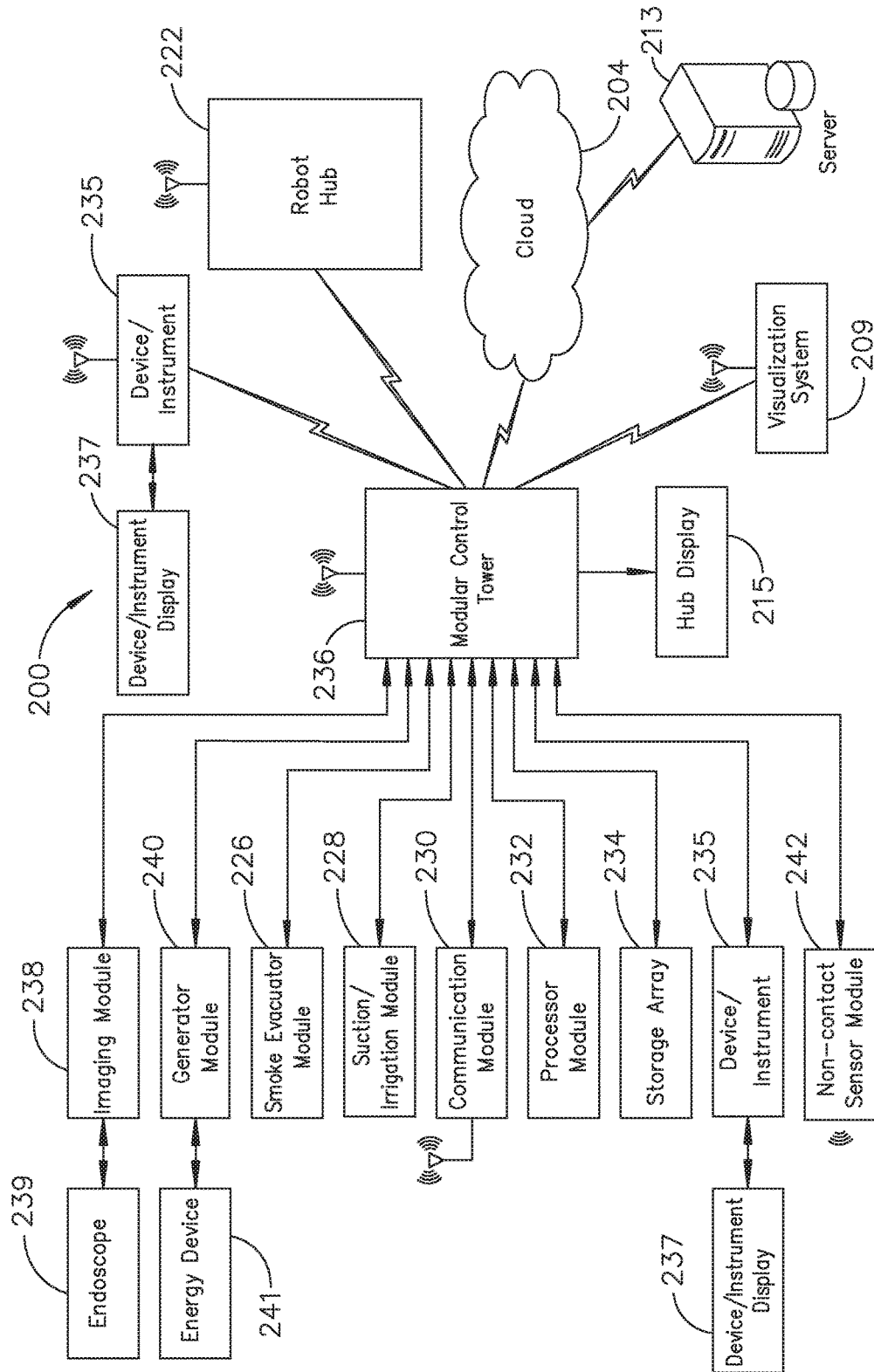

FIG. 9

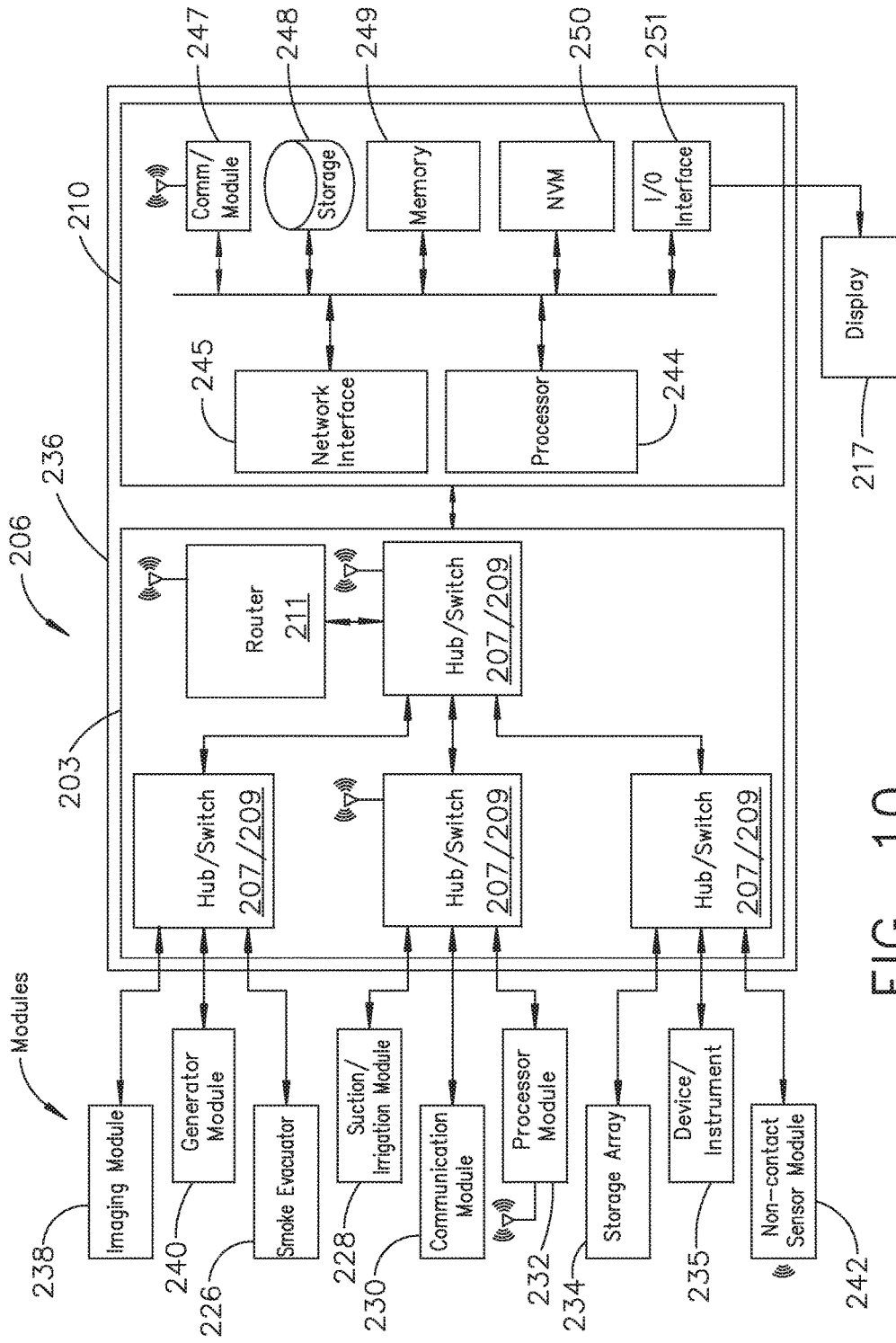

FIG. 10

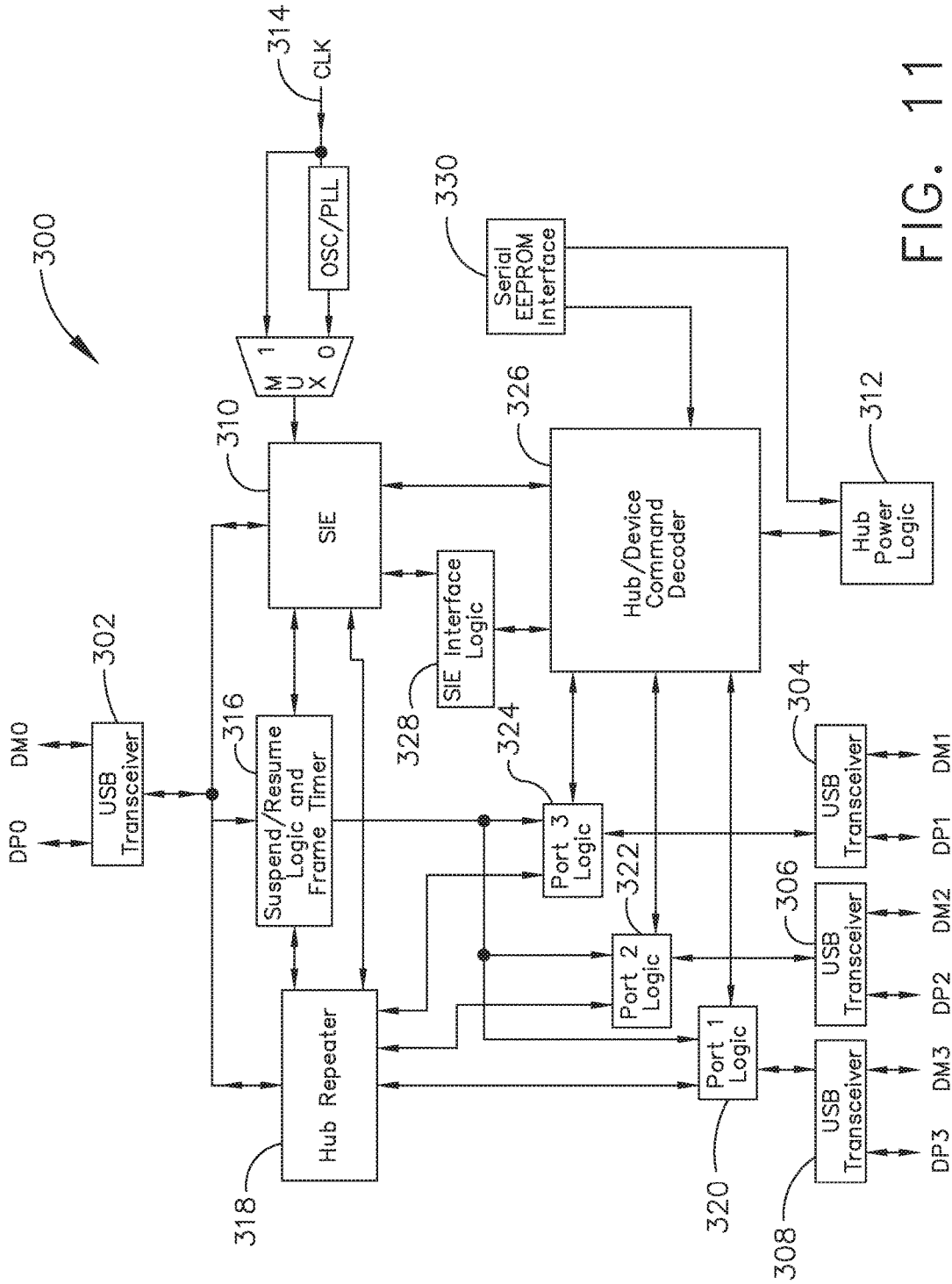

FIG. 11

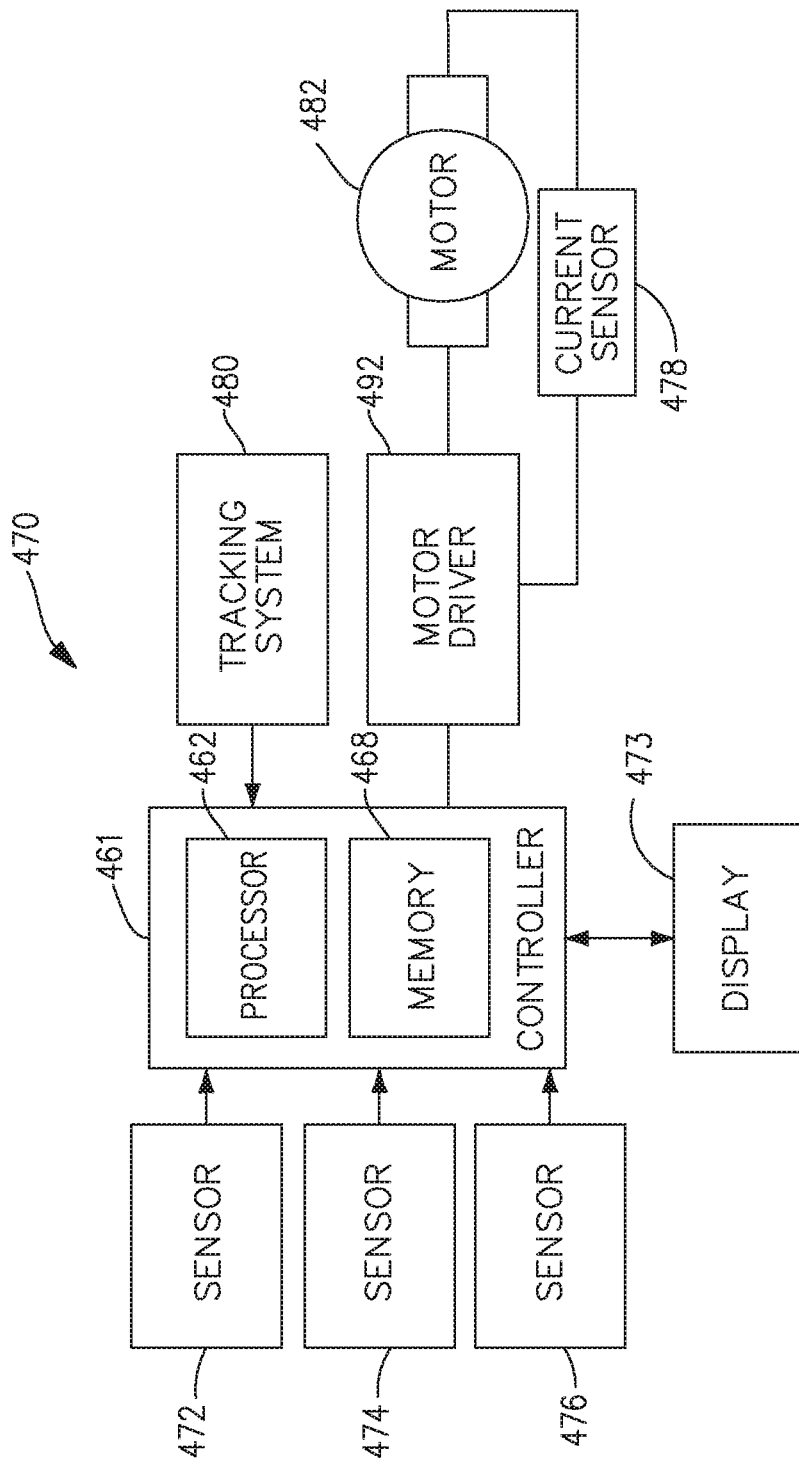

FIG. 12

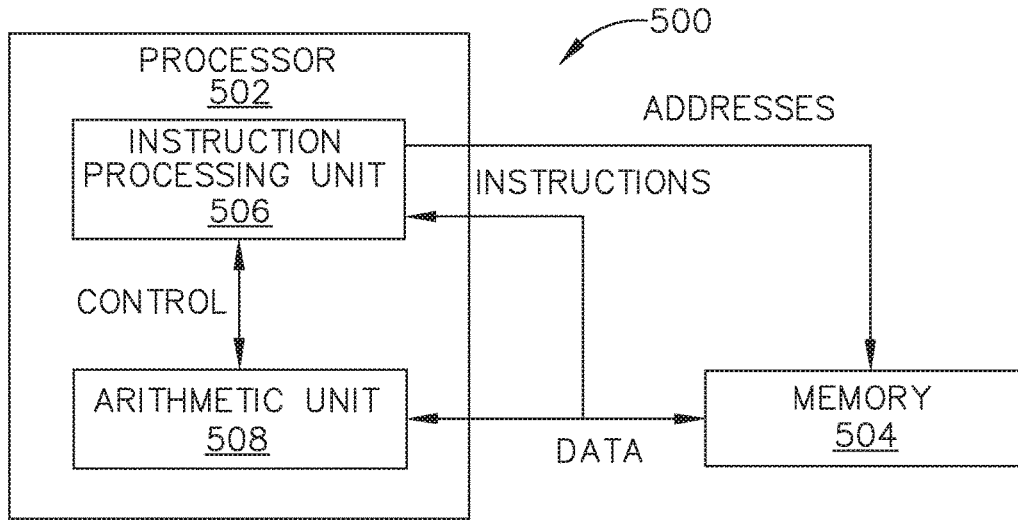

FIG. 13

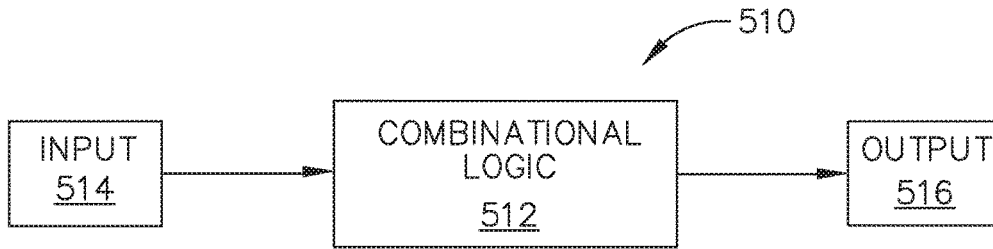

FIG. 14

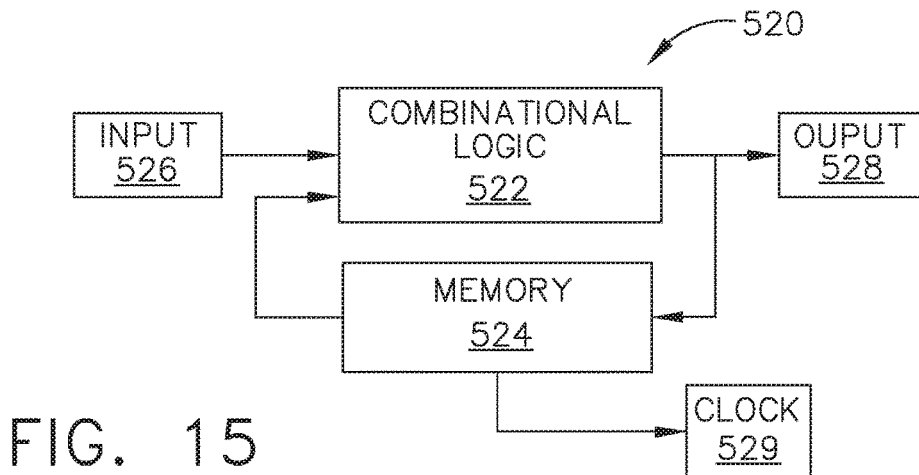

FIG. 15

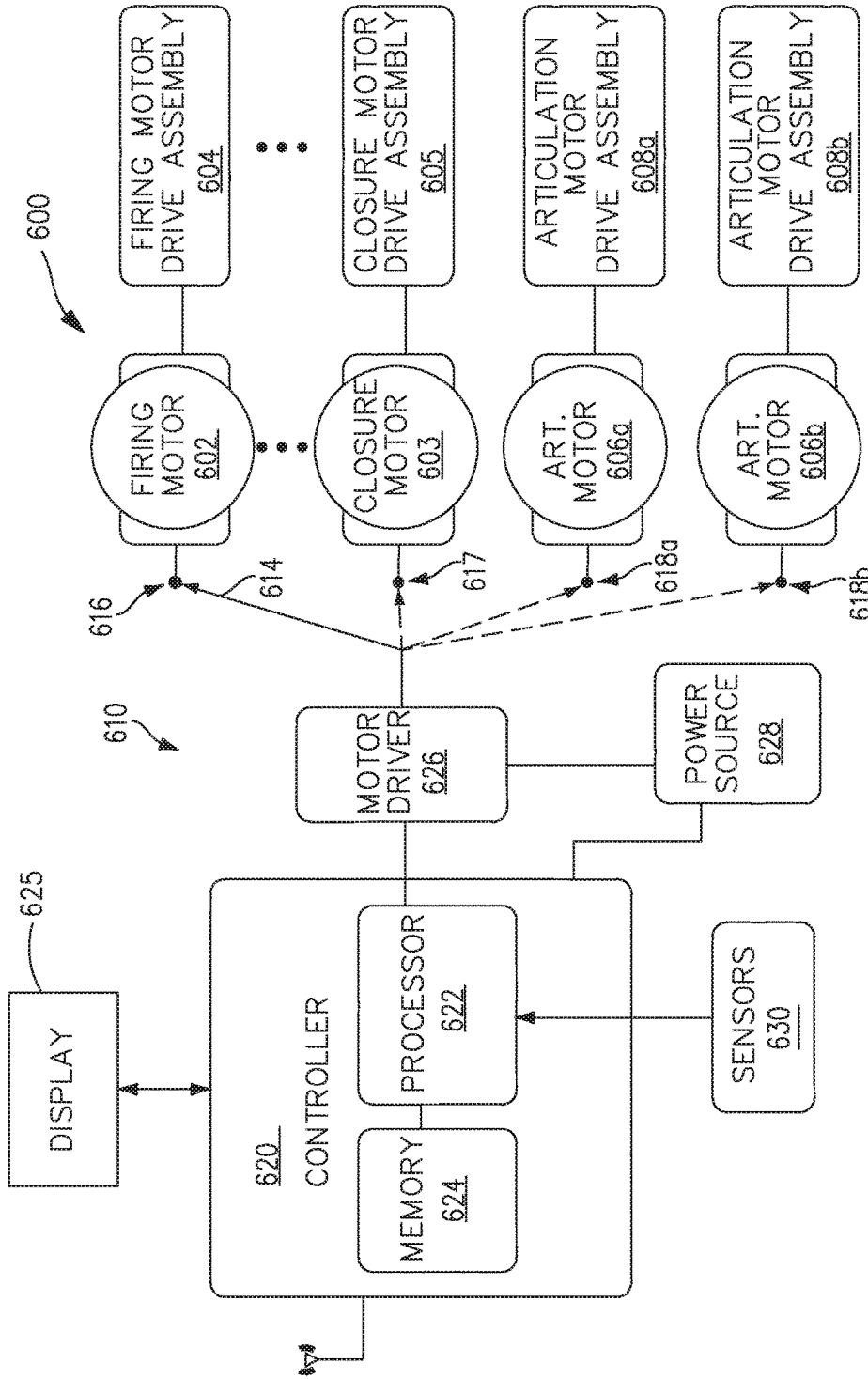

FIG. 16

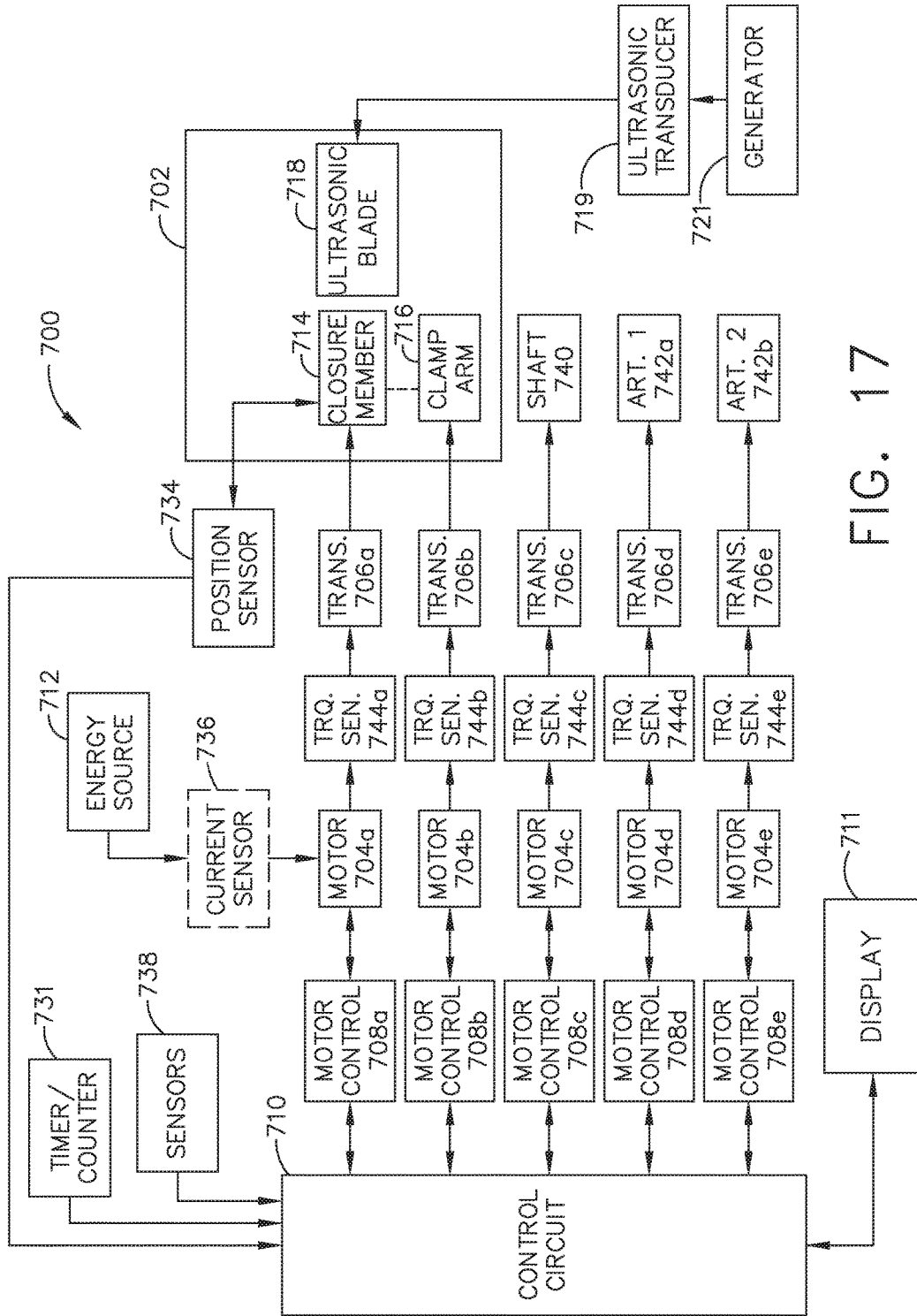

FIG. 17

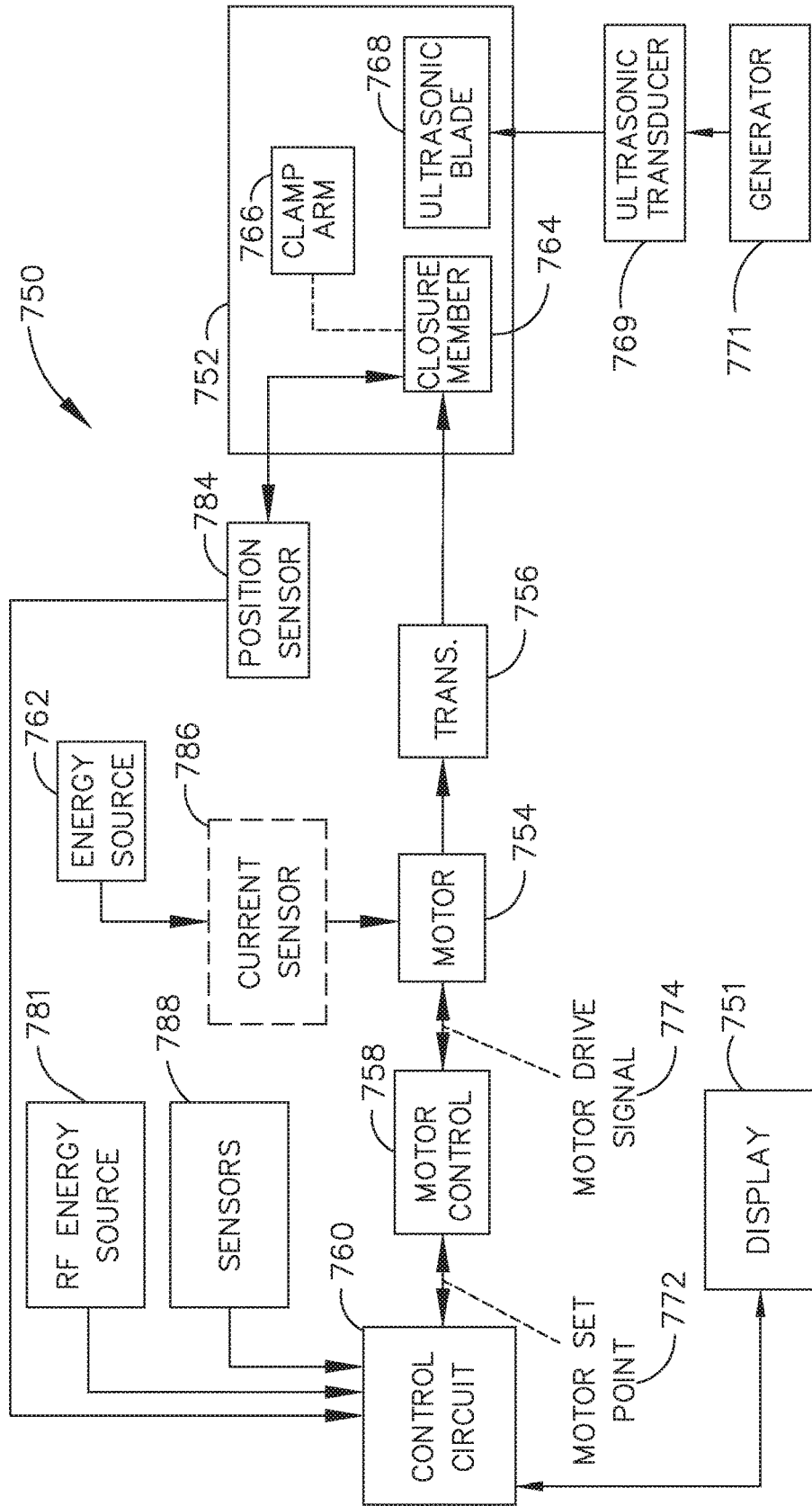

FIG. 18

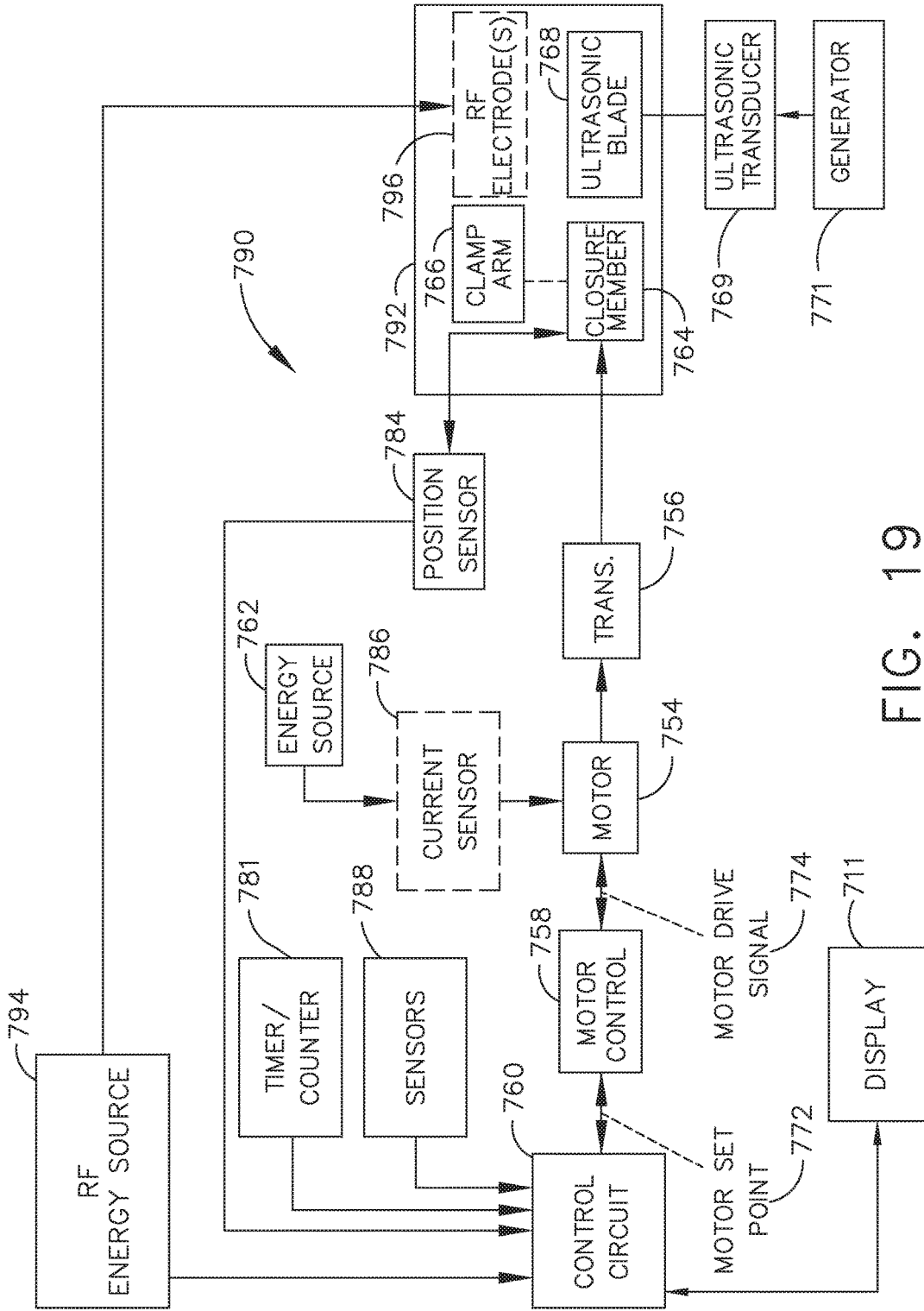

FIG. 19

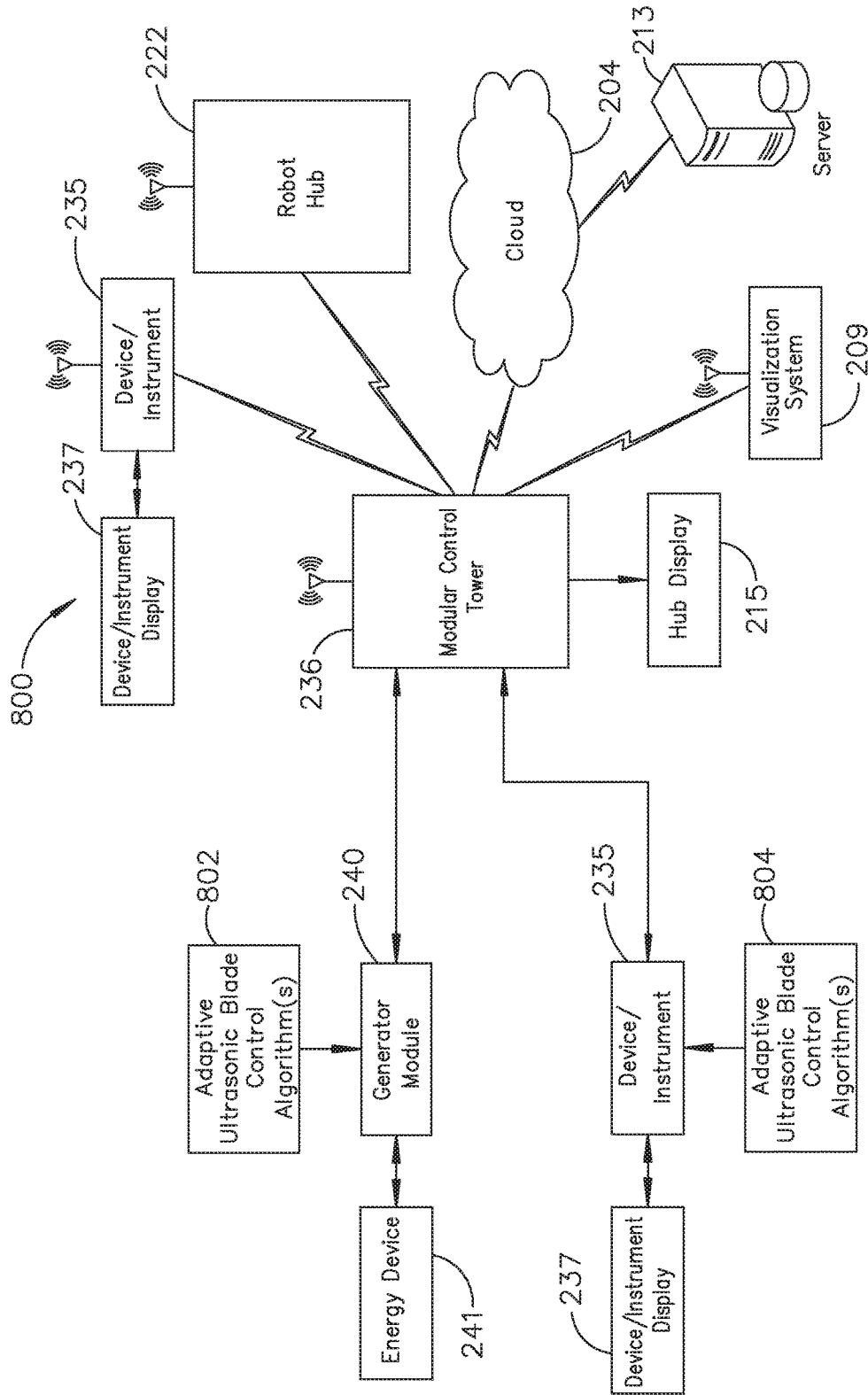

FIG. 20

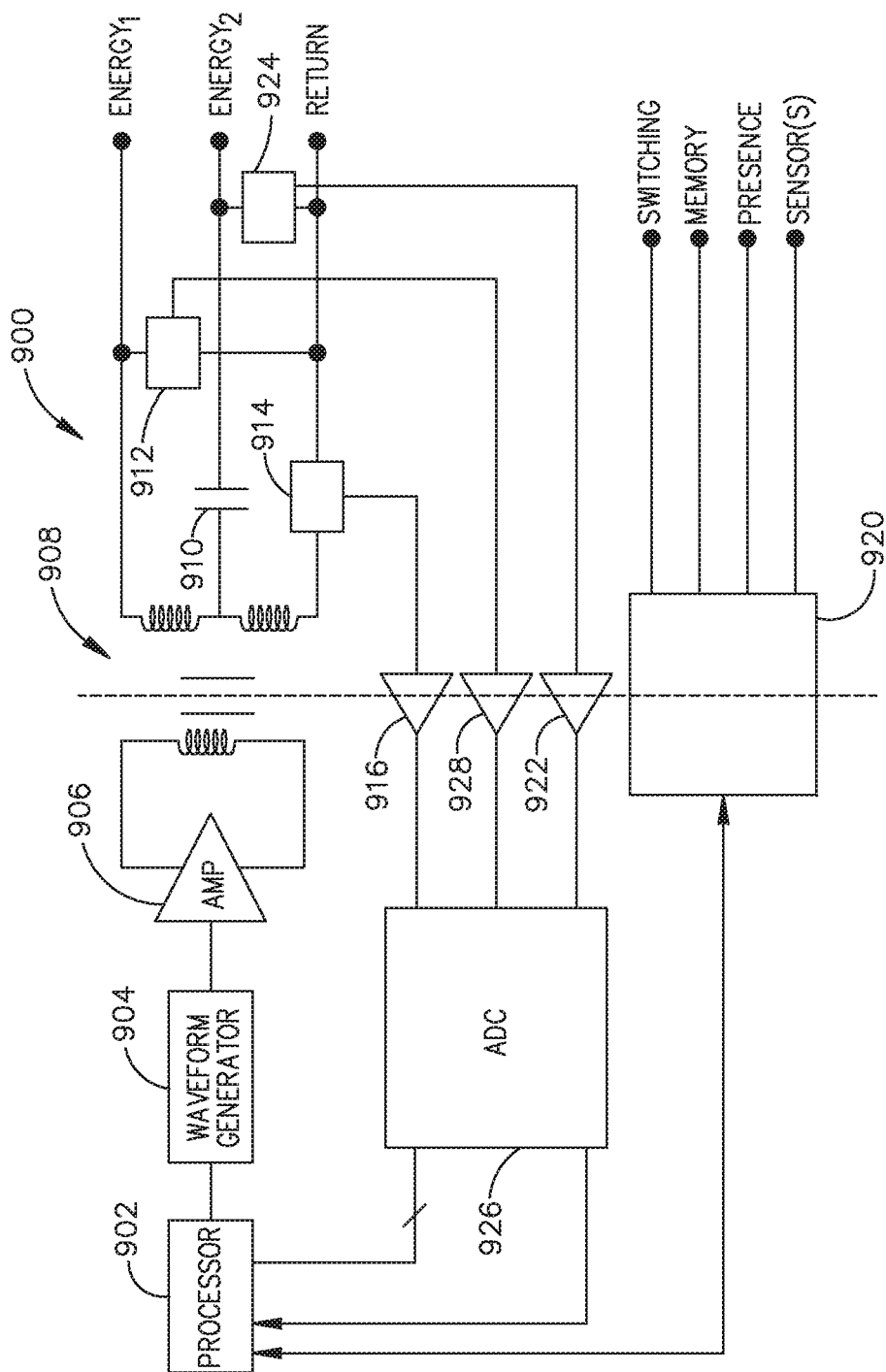

FIG. 21

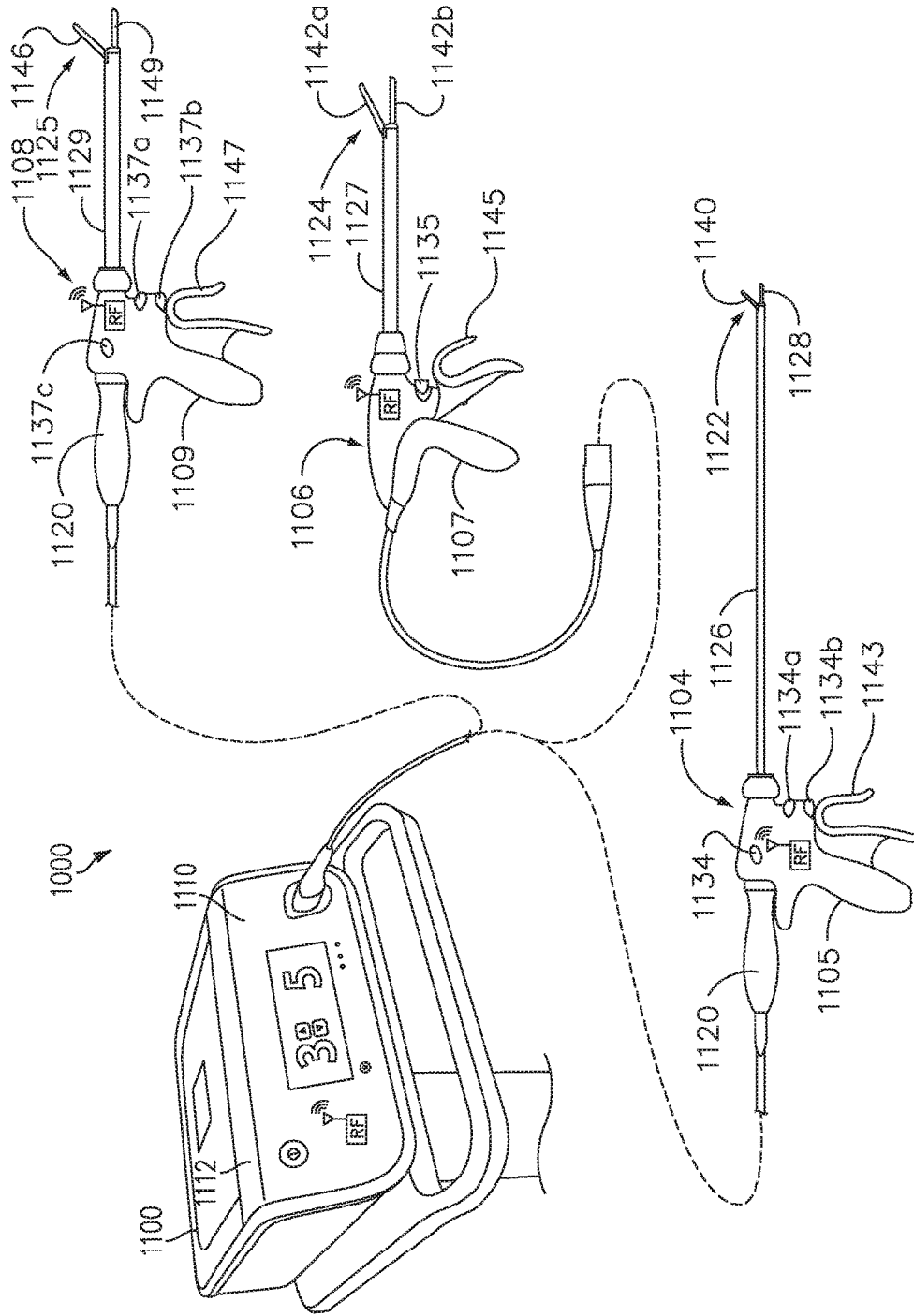

FIG. 22

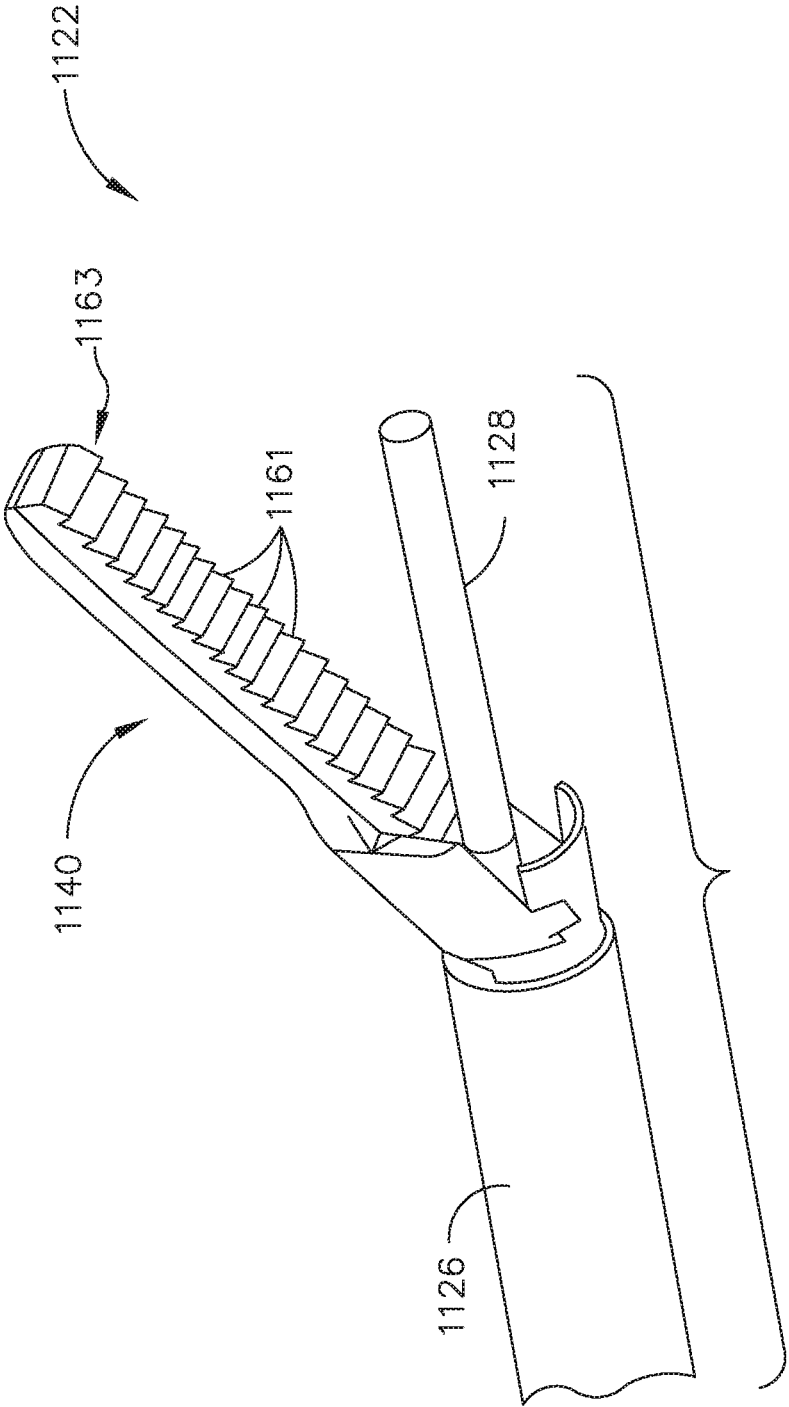

FIG. 23

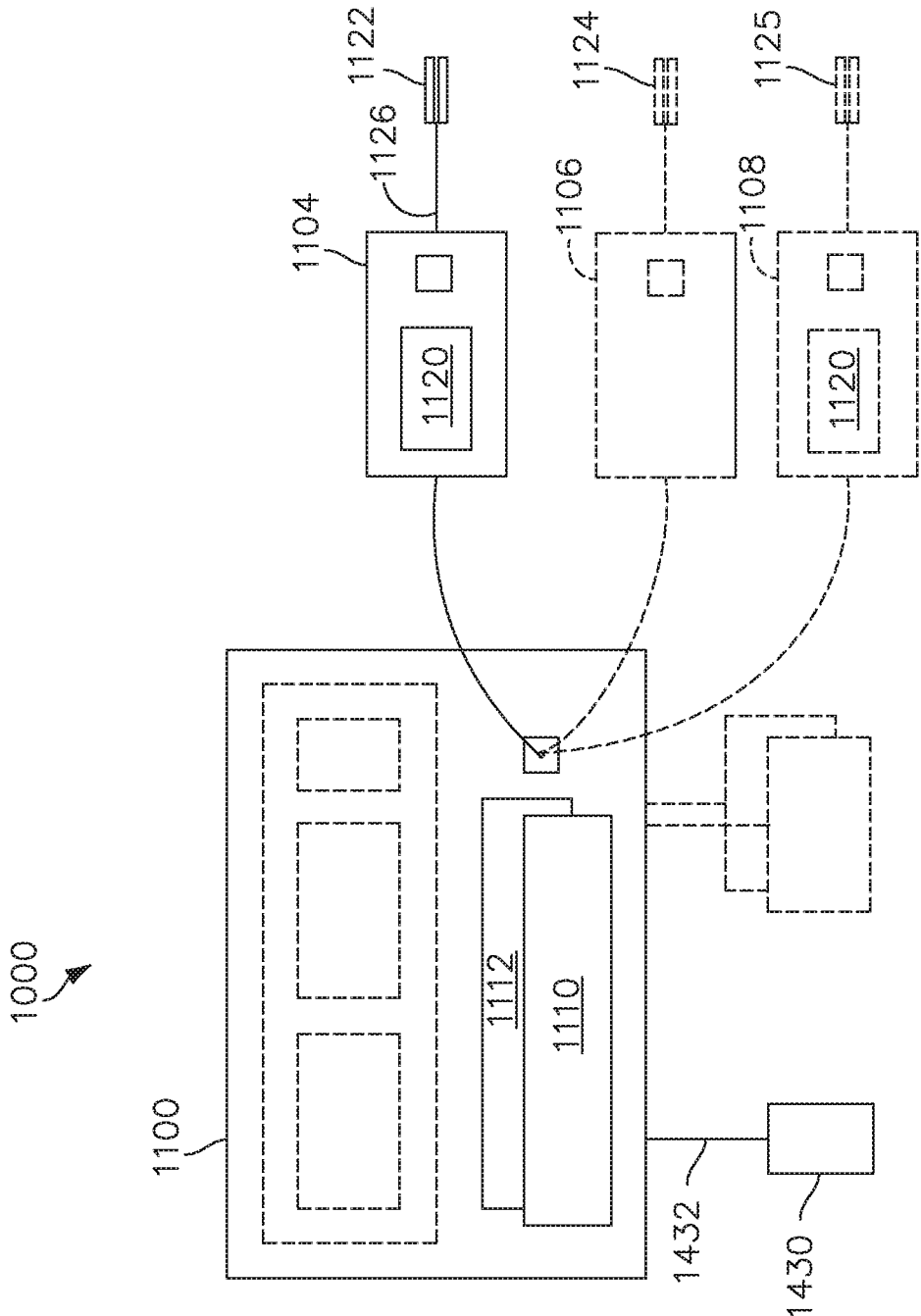

FIG. 24

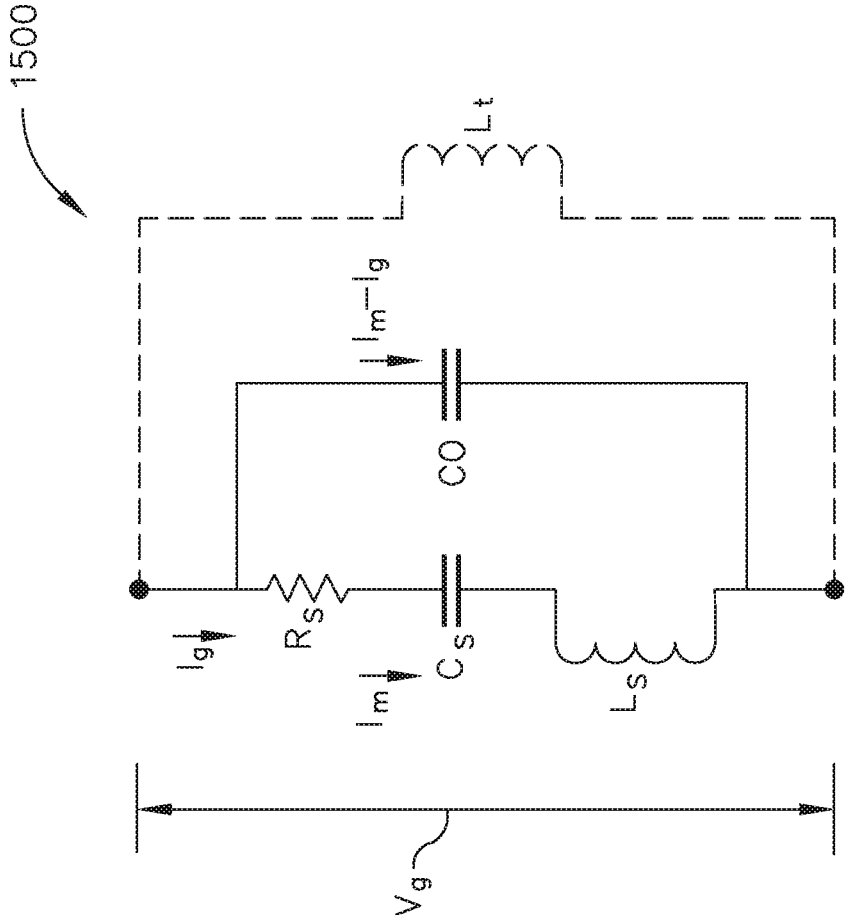

FIG. 25

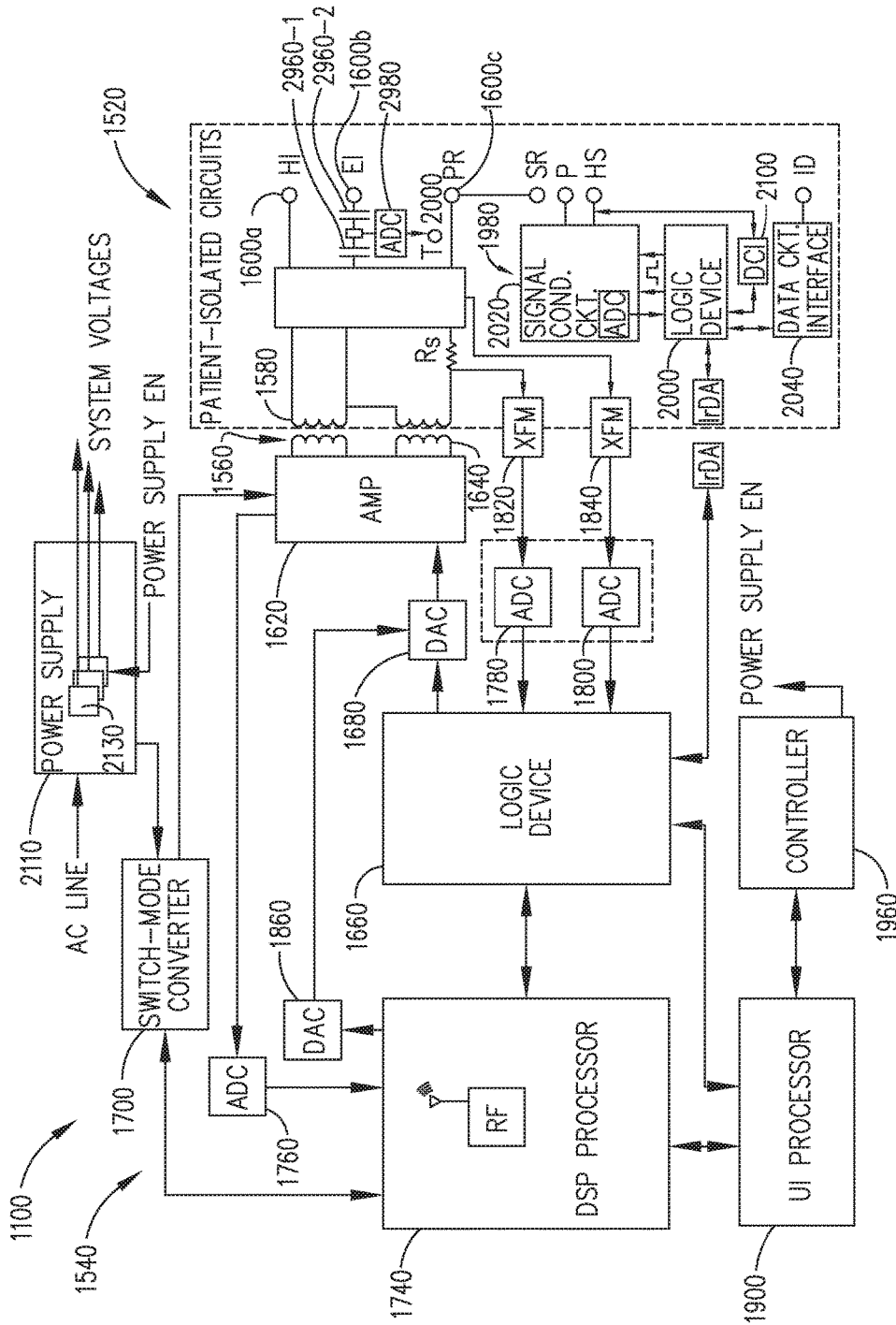

FIG. 26

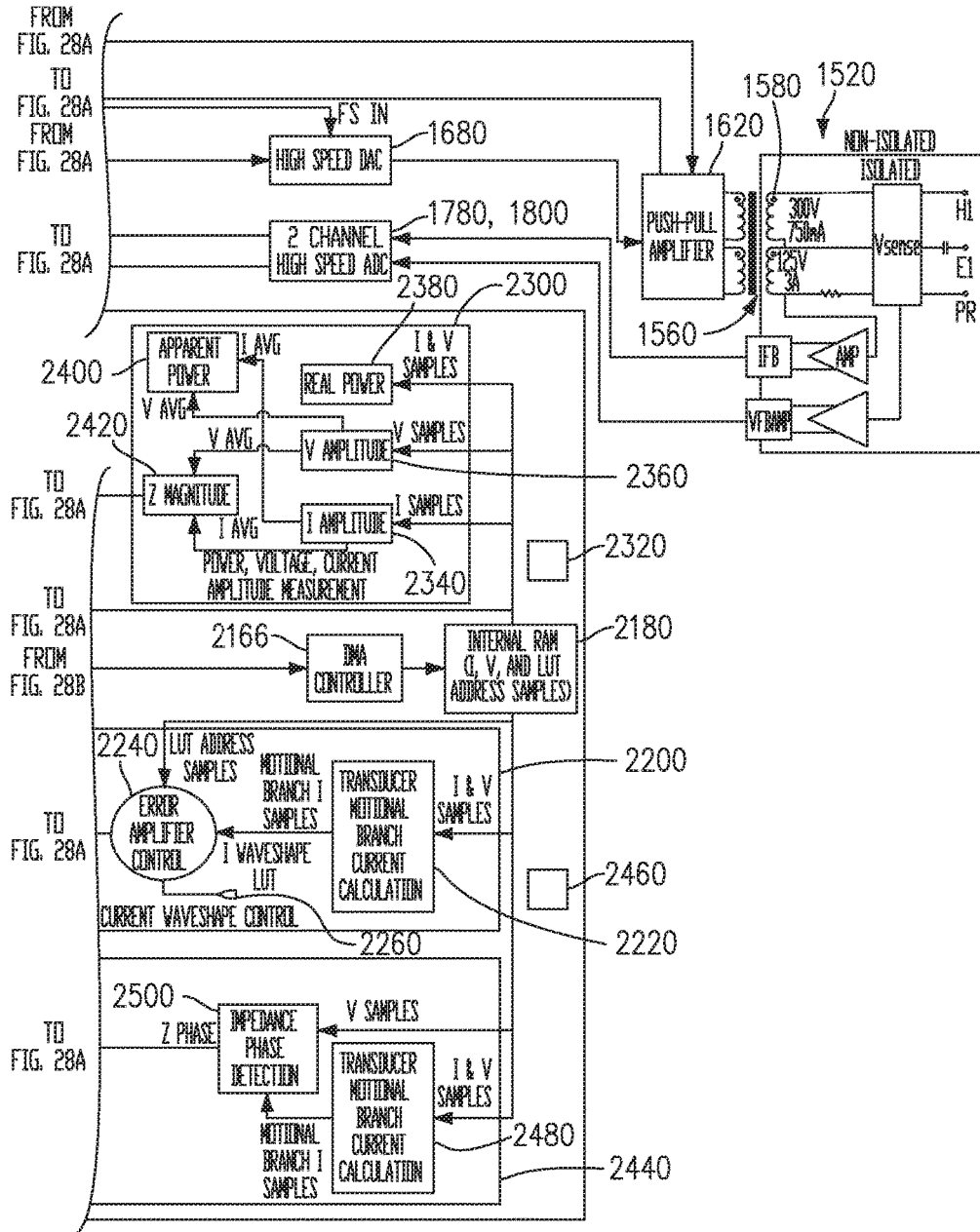
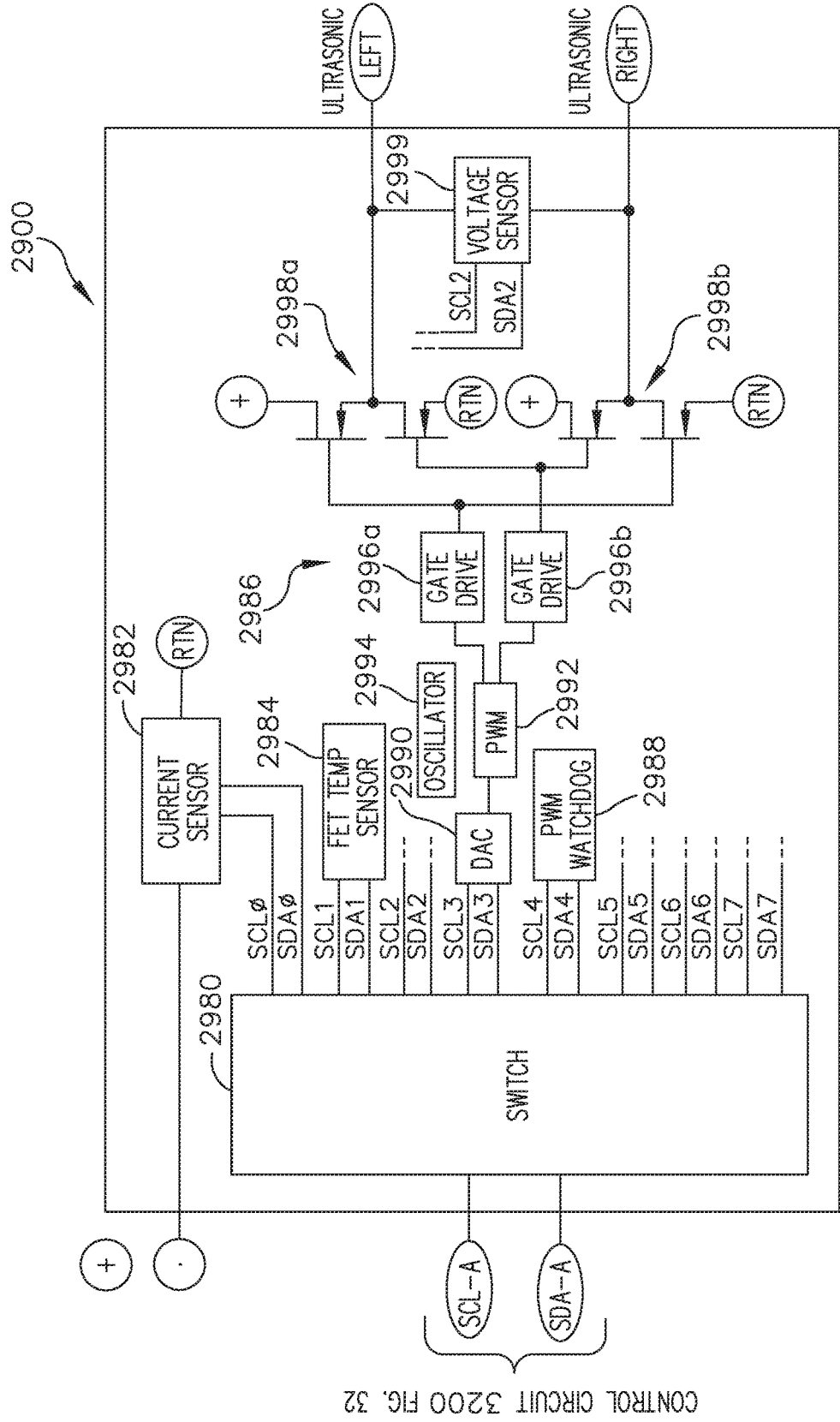

FIG. 28B



CONTROL CIRCUIT 3200 FIG. 32

FIG. 29

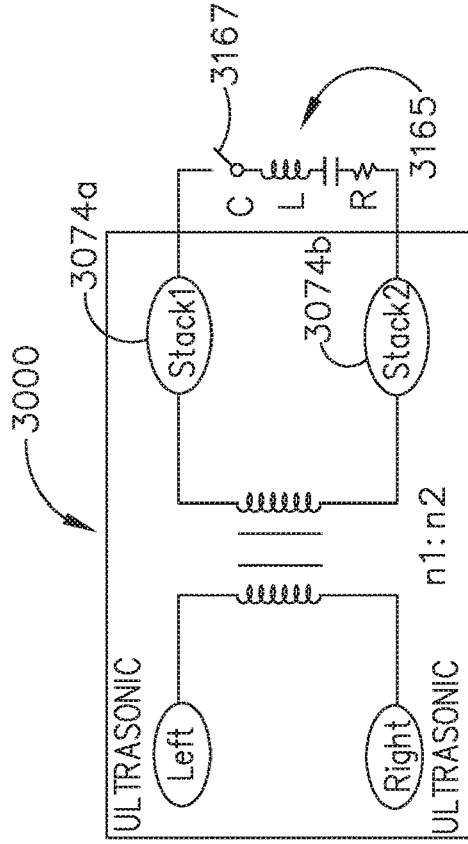

FIG. 31

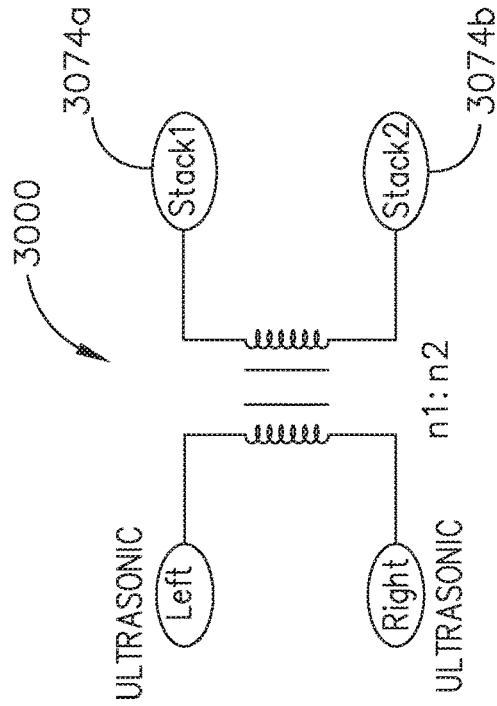

FIG. 30

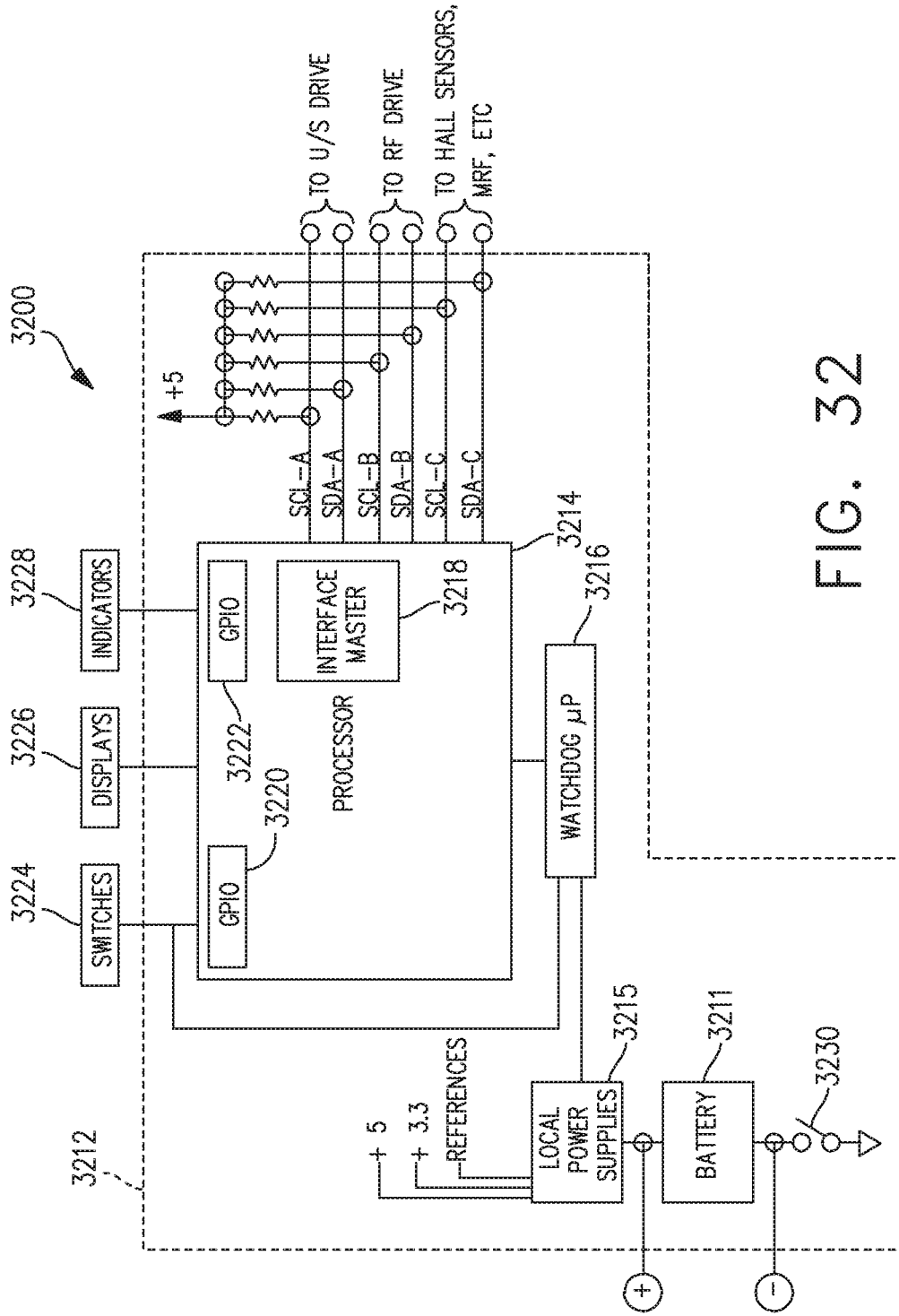

FIG. 32

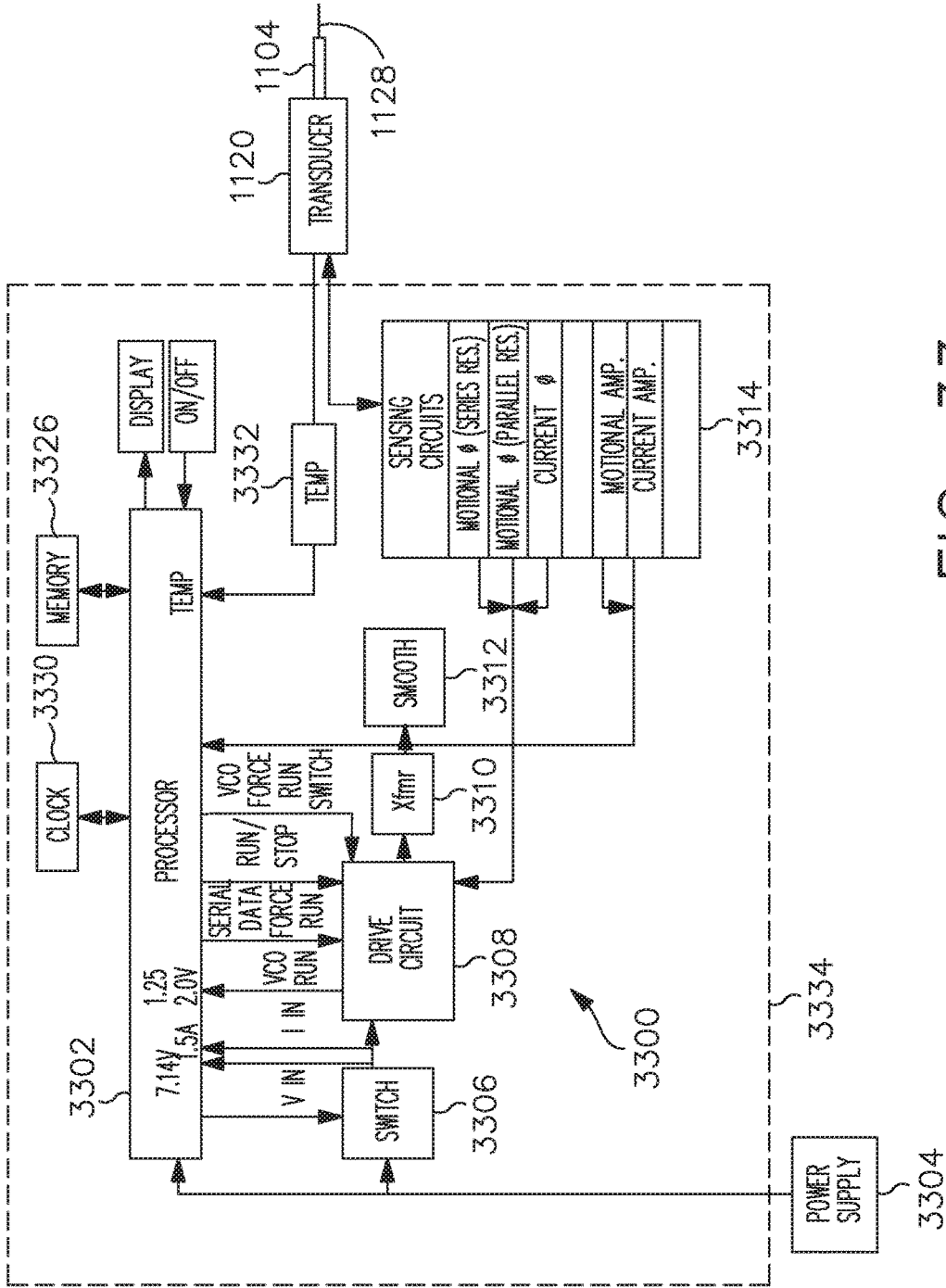

FIG. 33

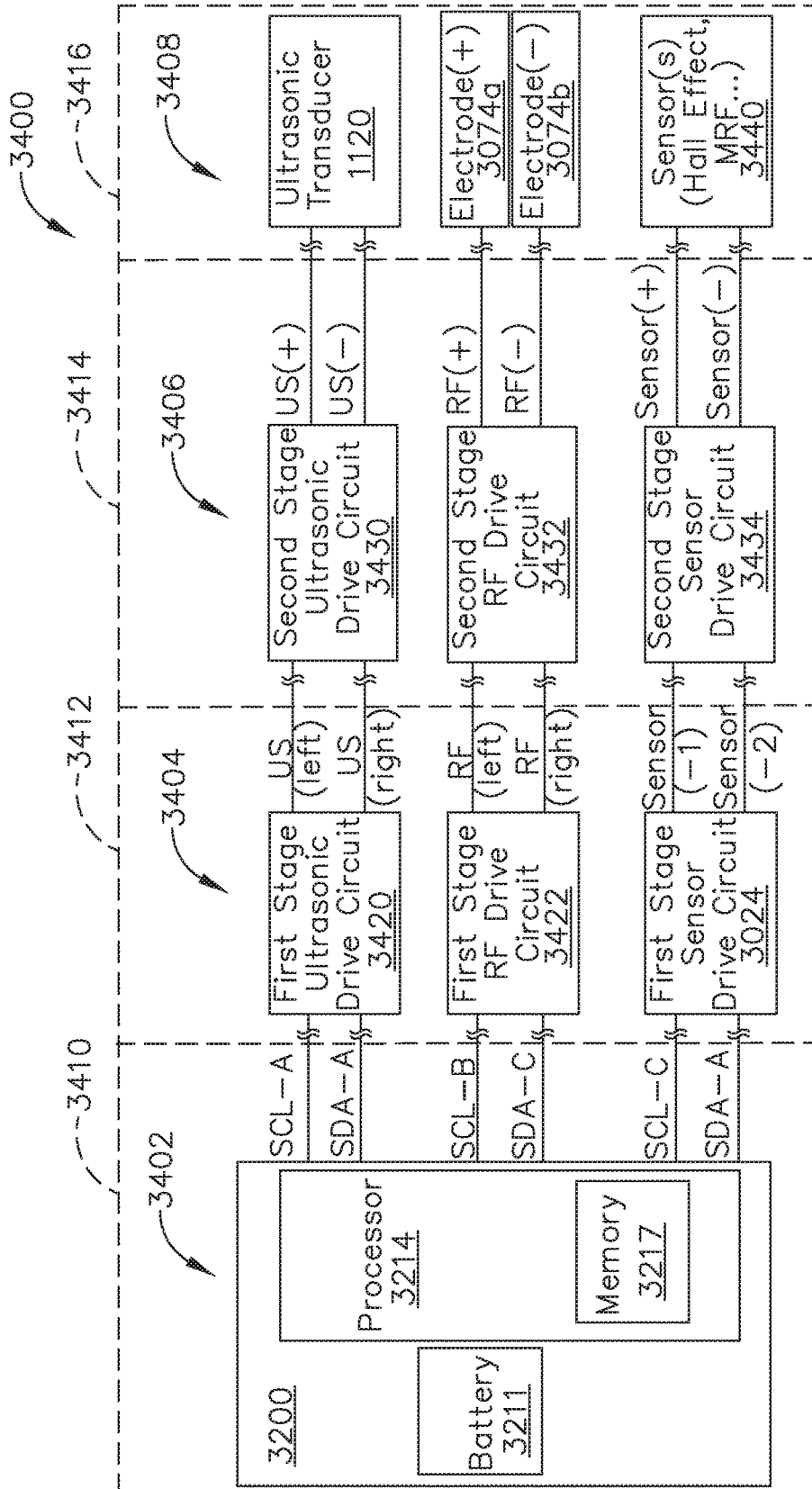

FIG. 34

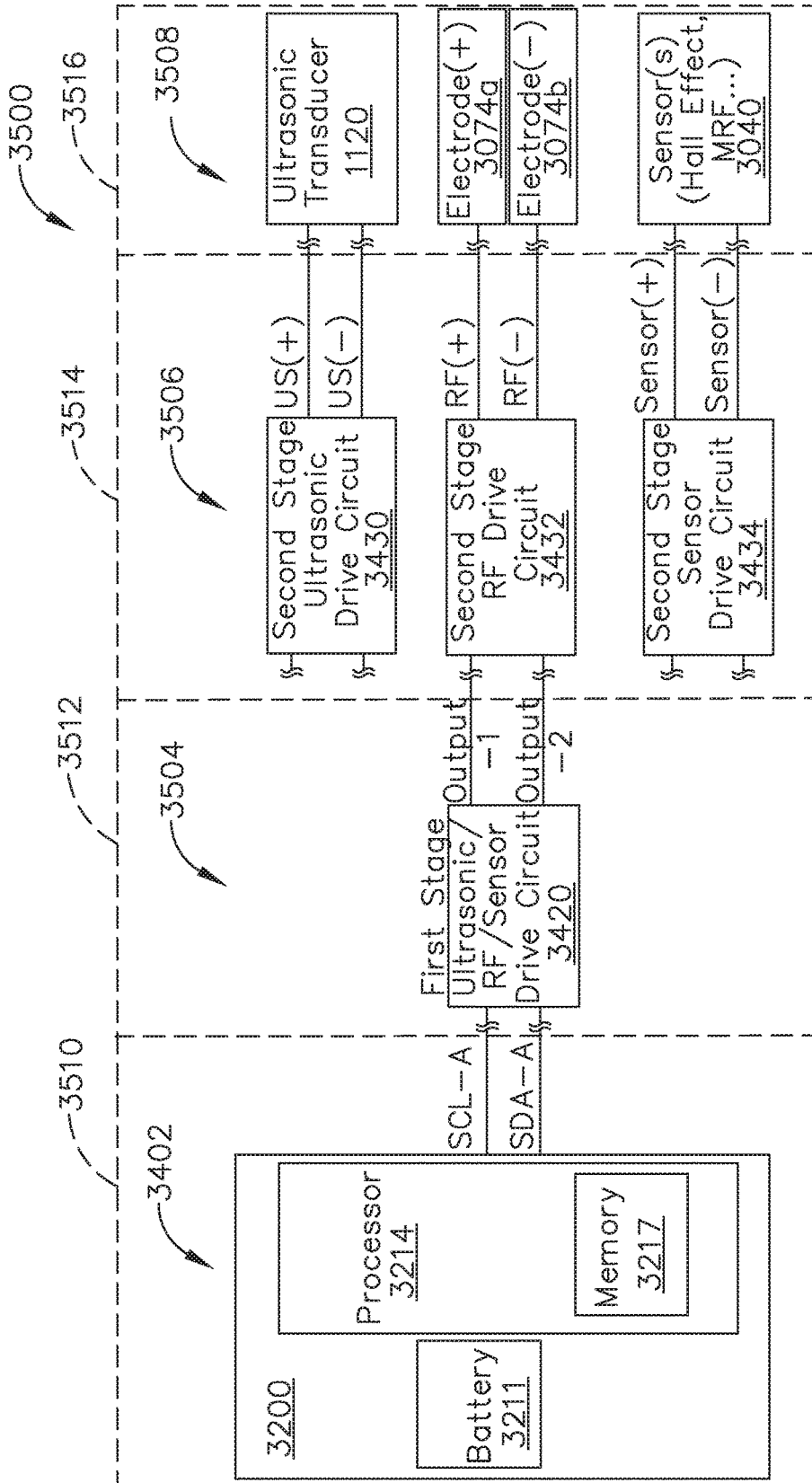

FIG. 35

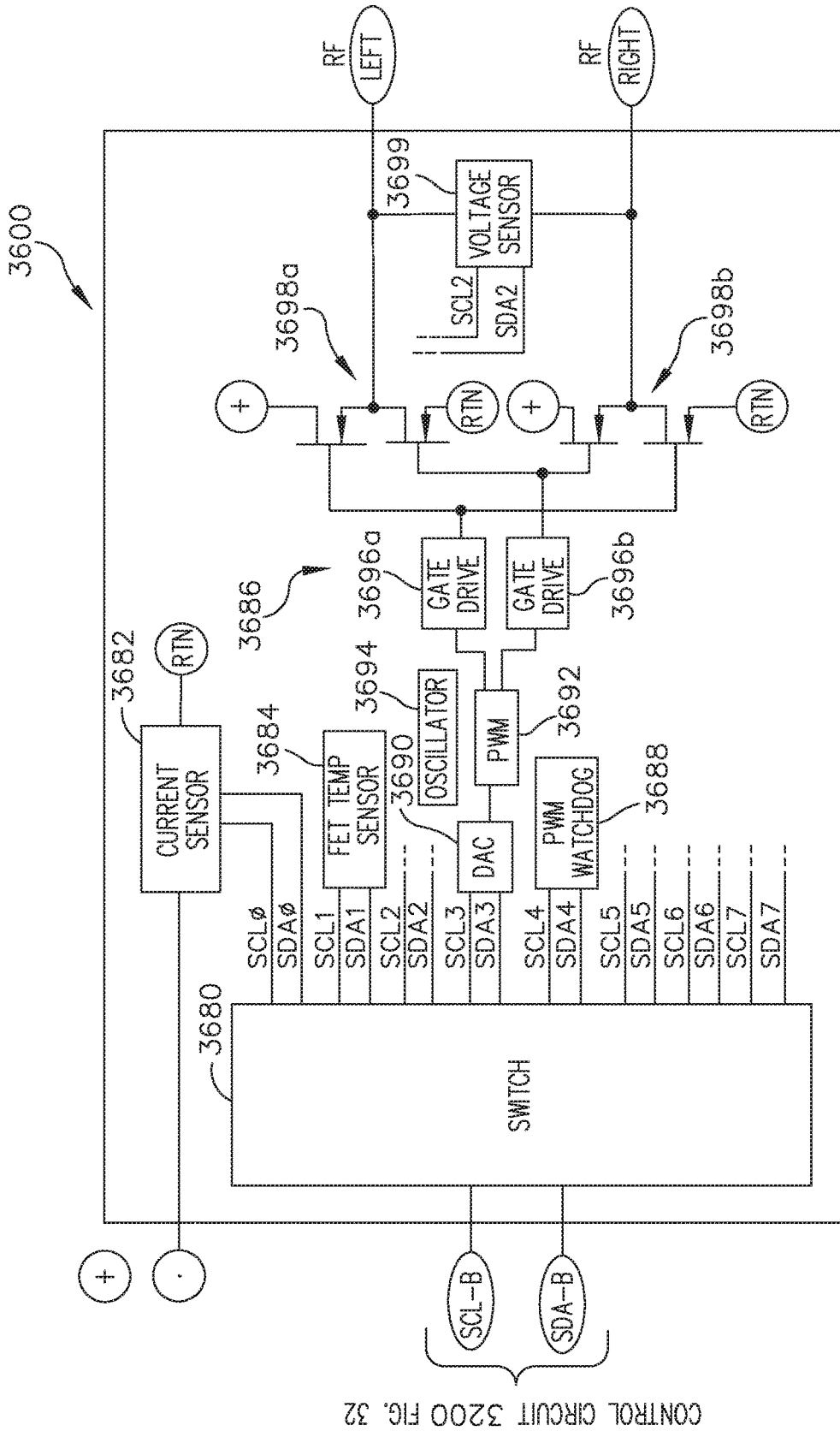

FIG. 36

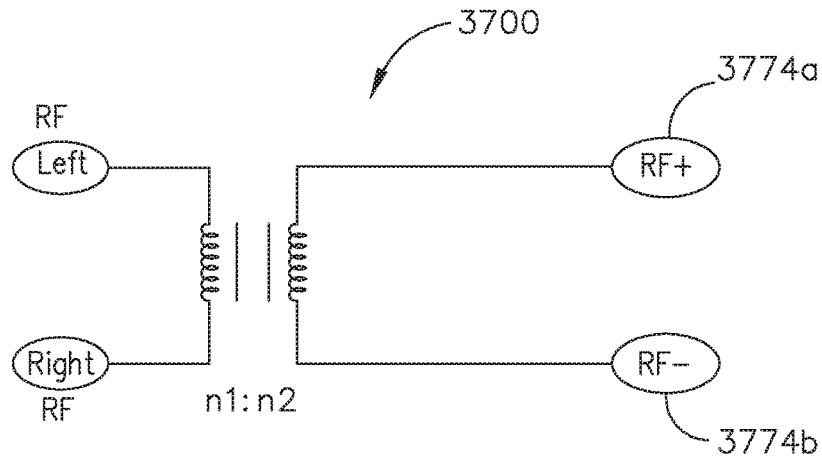

FIG. 37

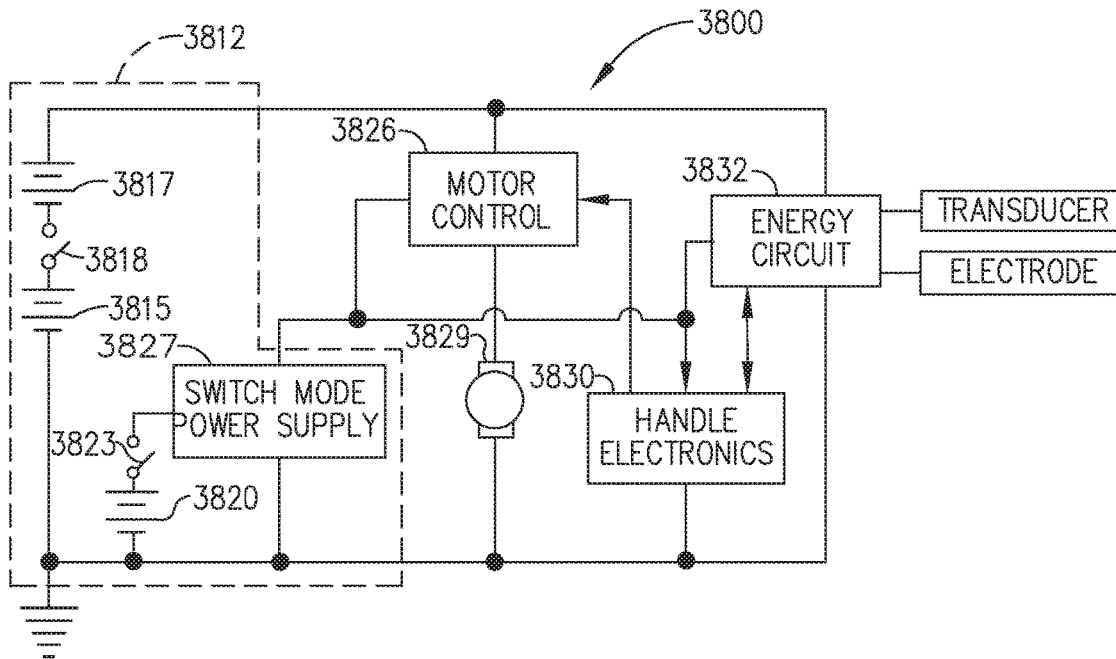

FIG. 38

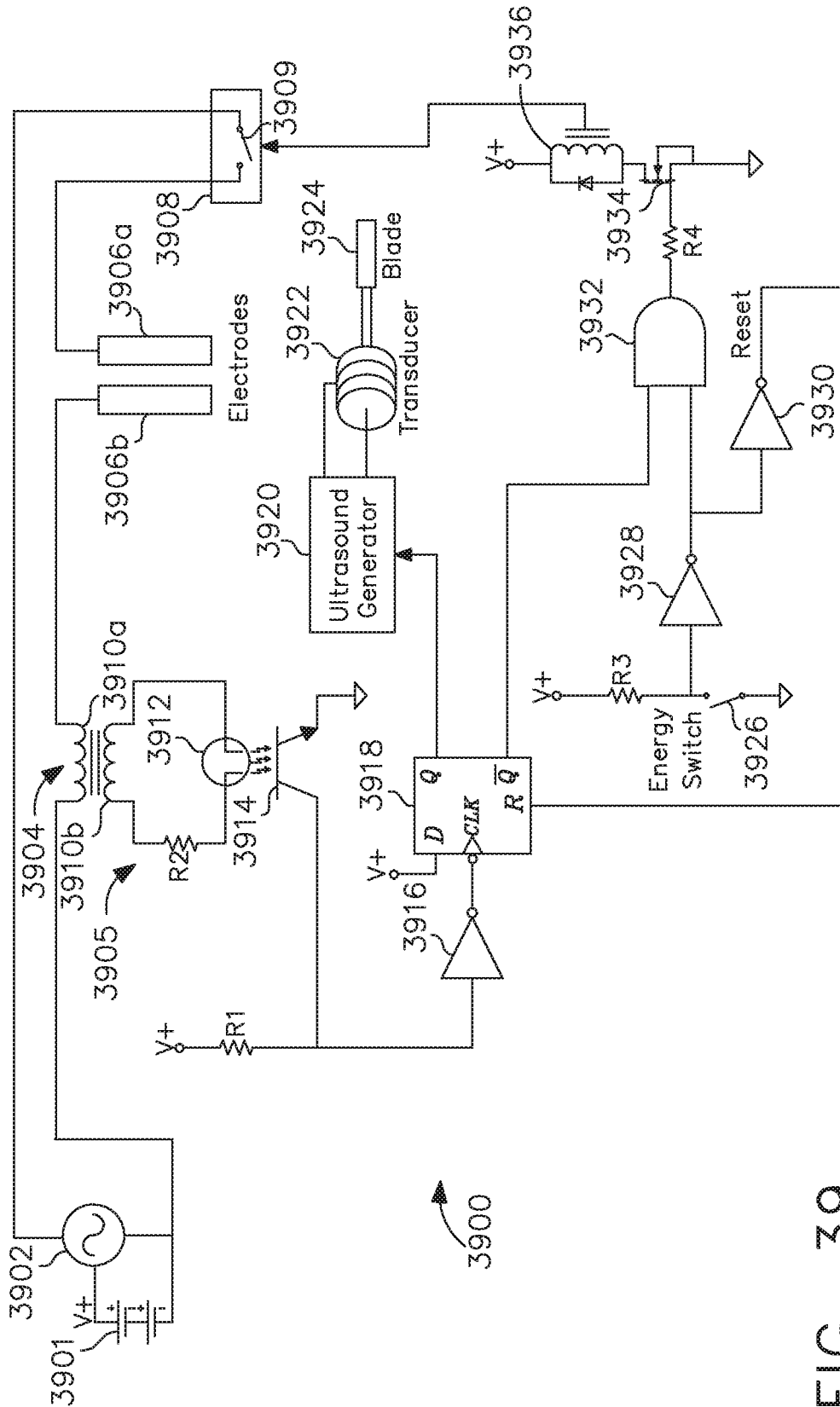

FIG. 39

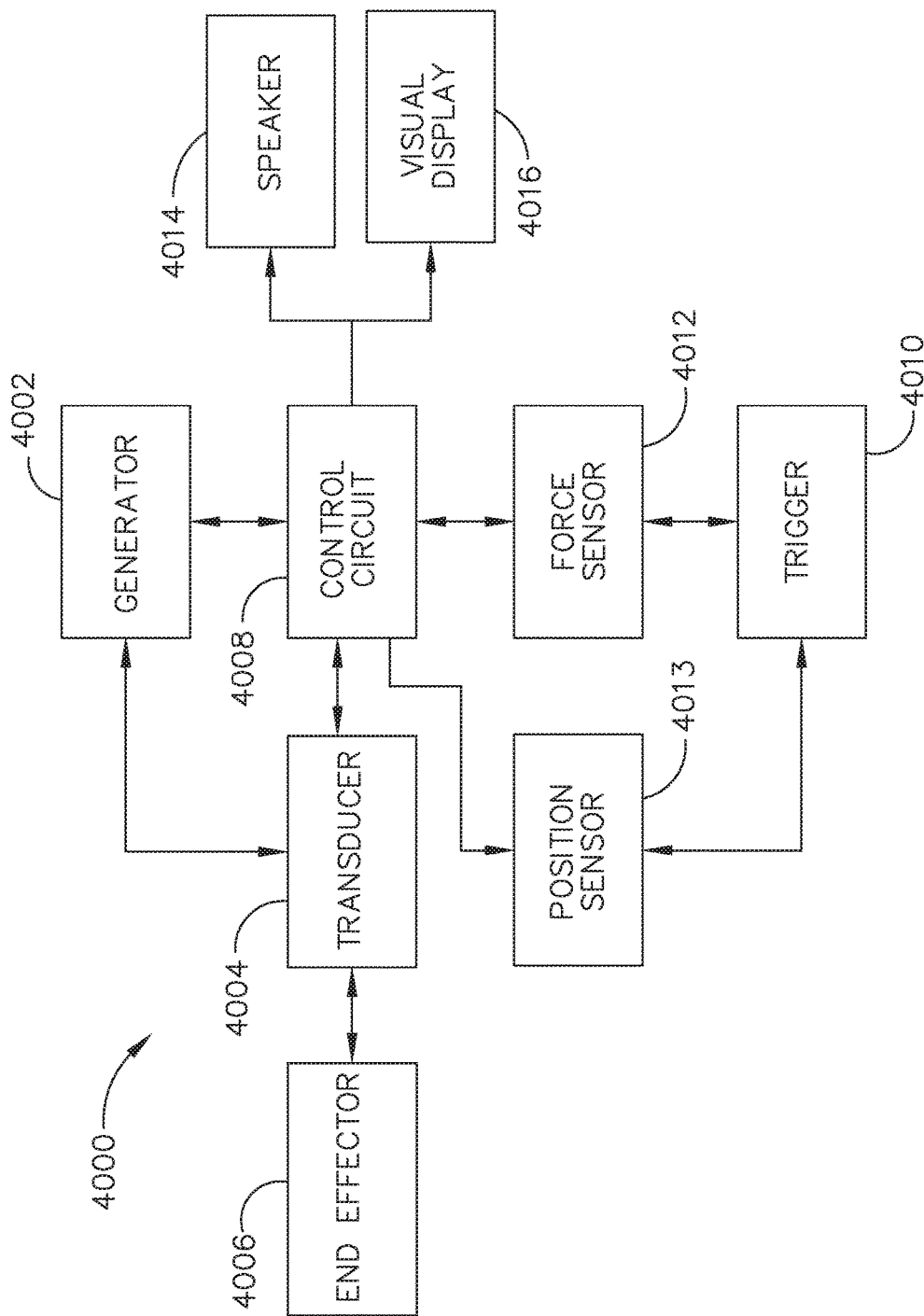

FIG. 40

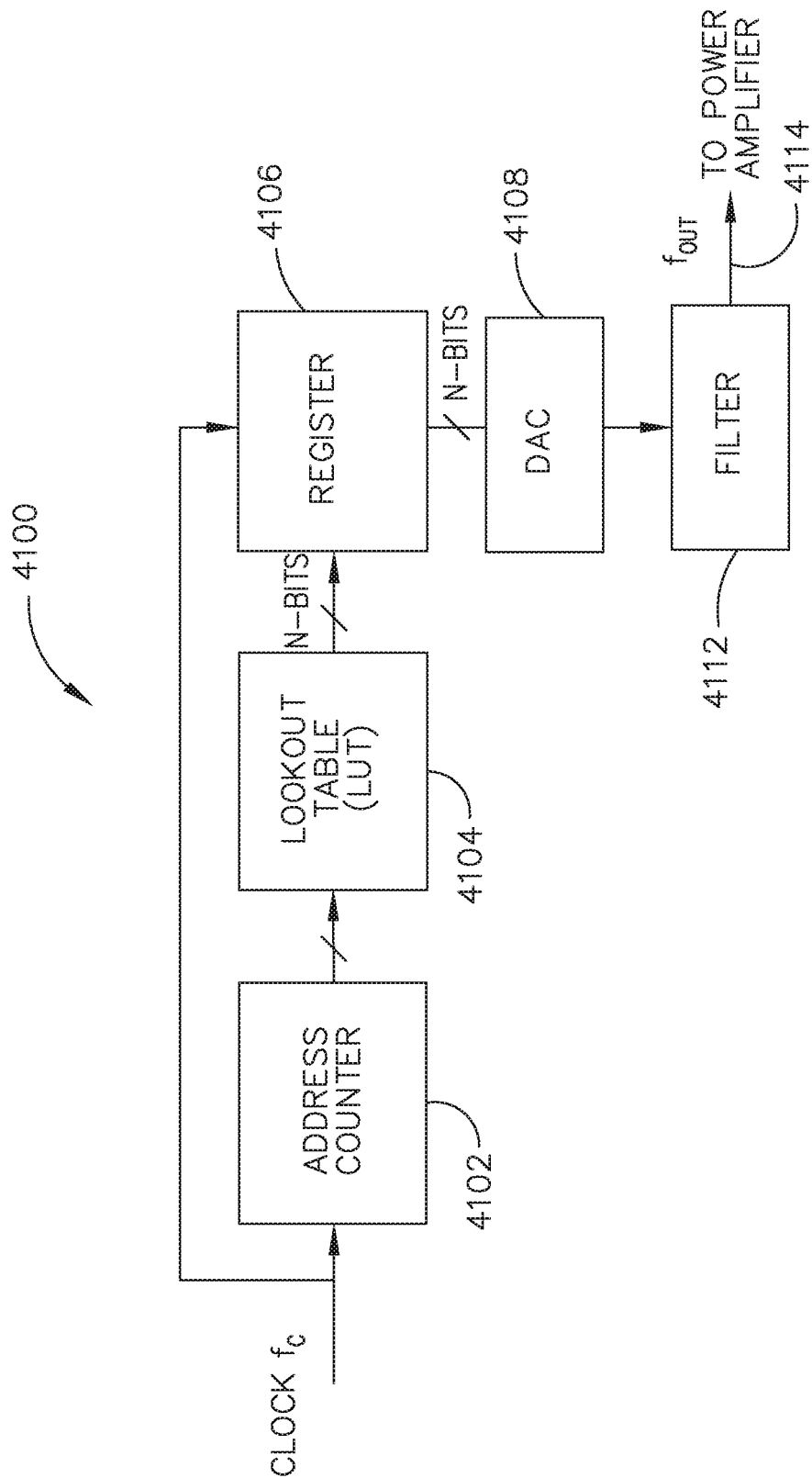

FIG. 41

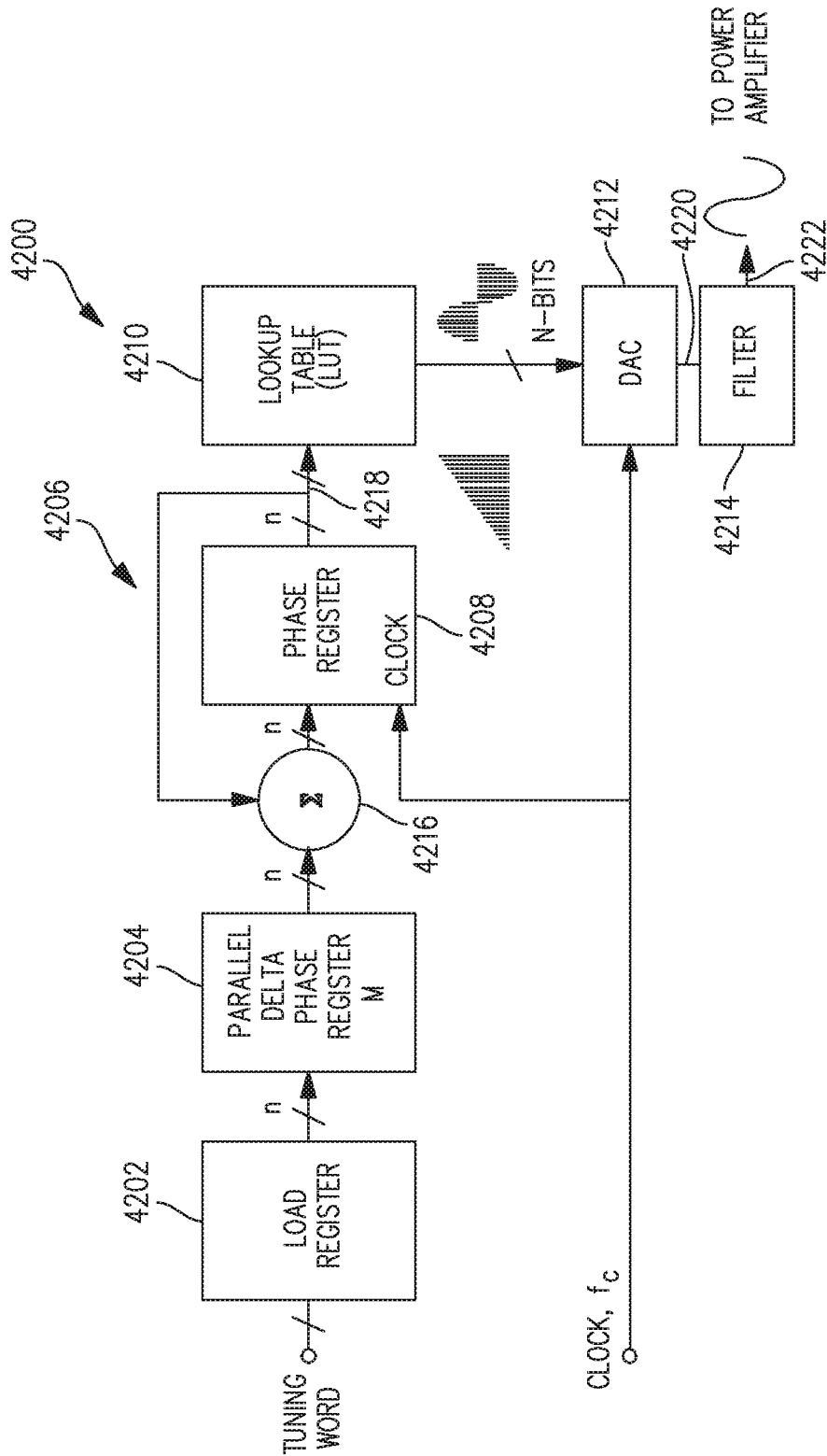

FIG. 42

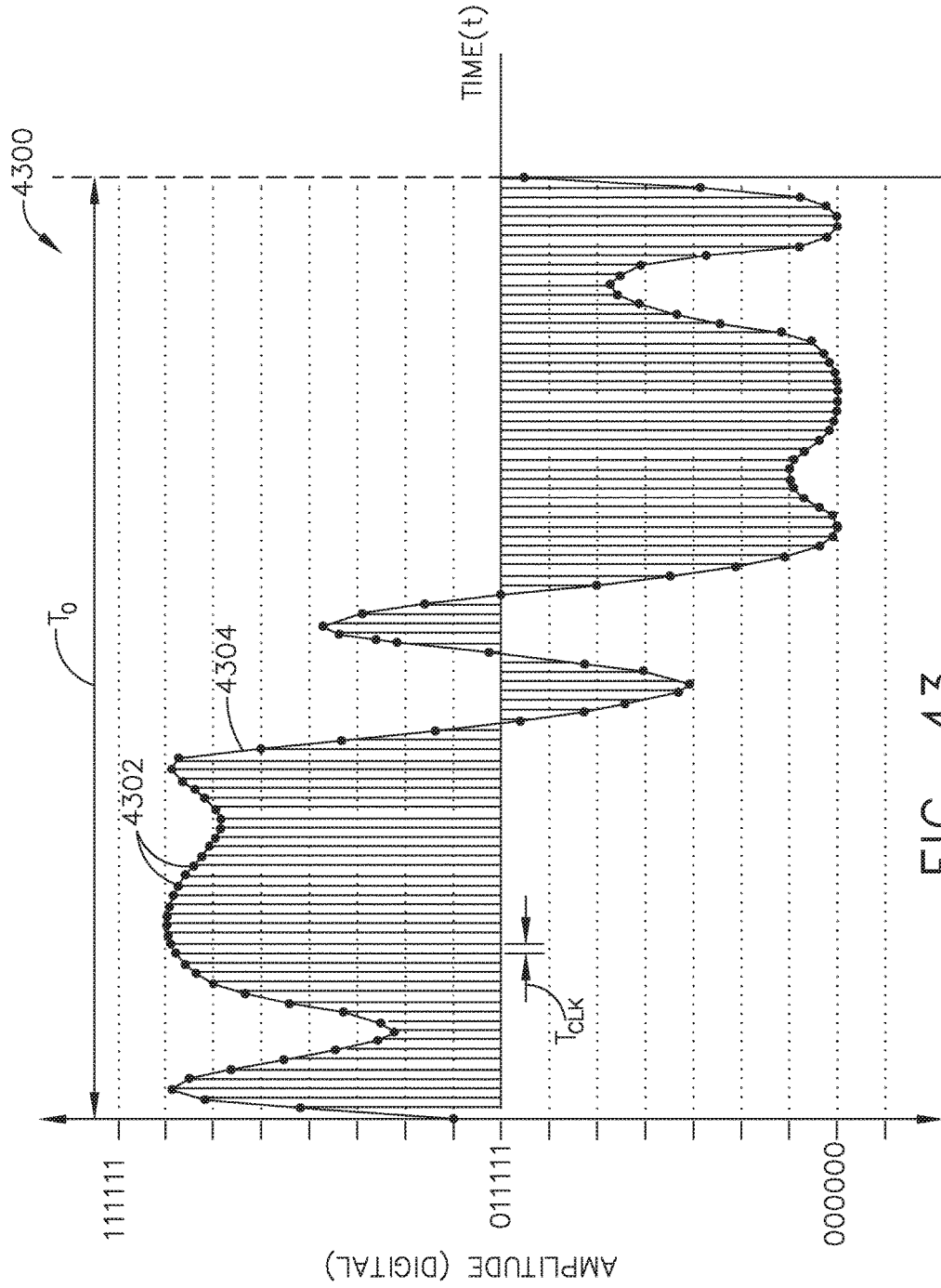

FIG. 43

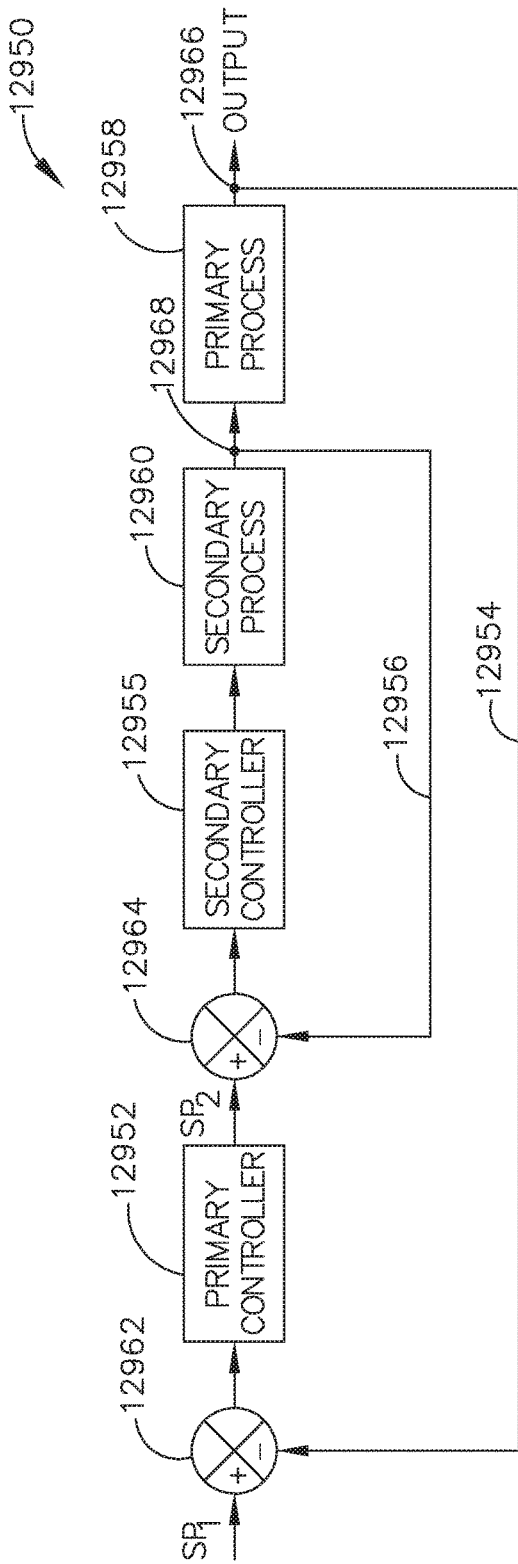

FIG. 44

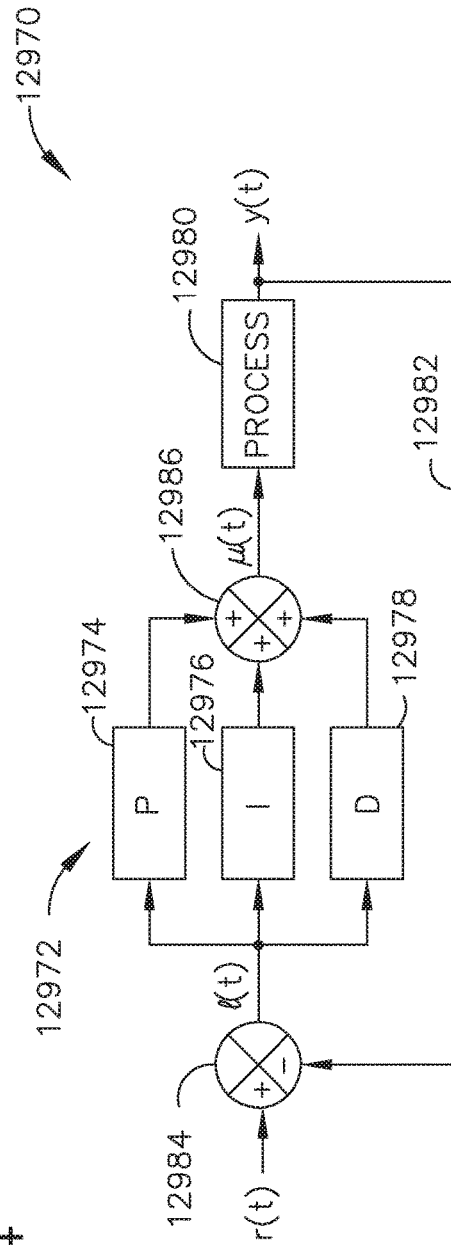

FIG. 45

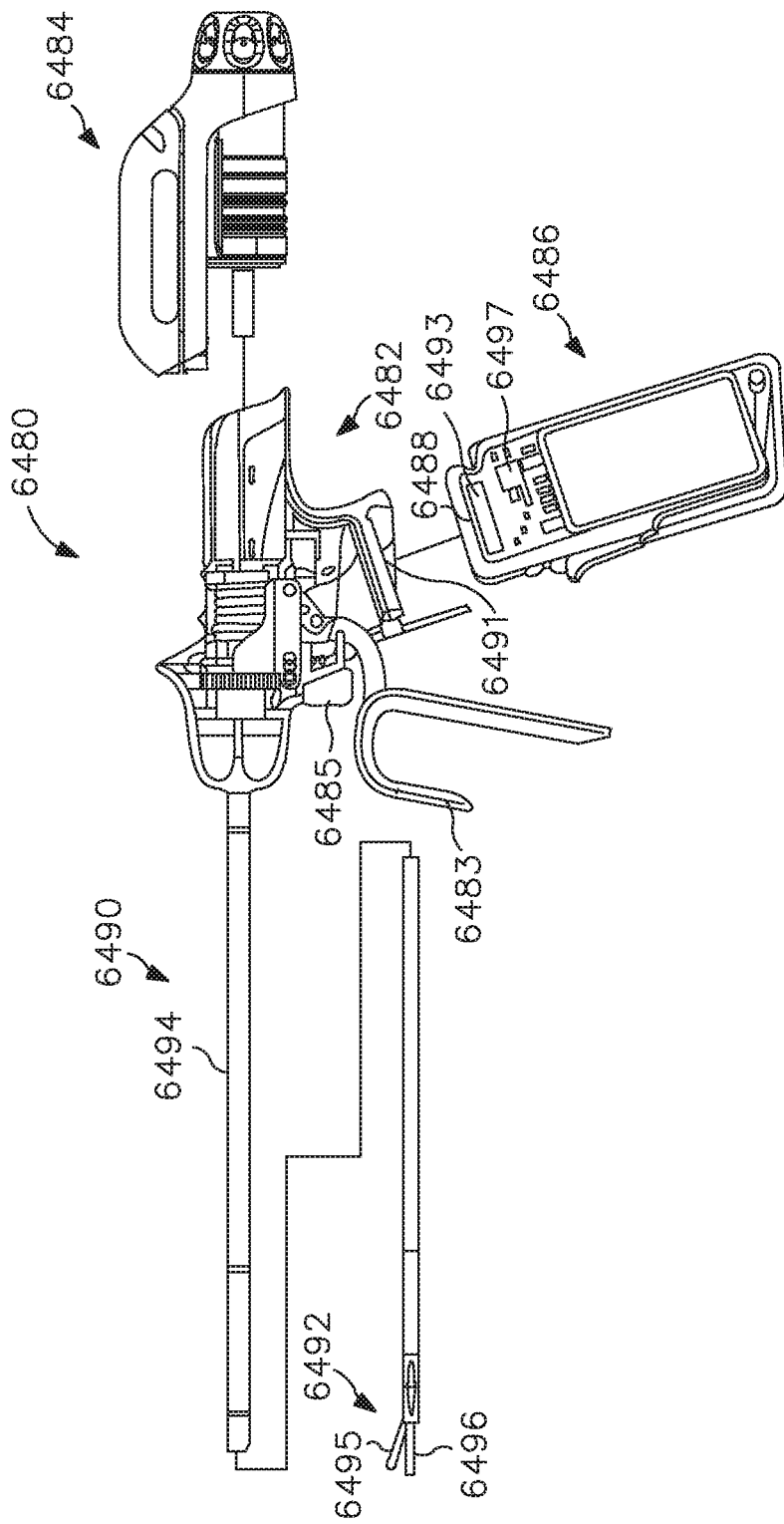

FIG. 46

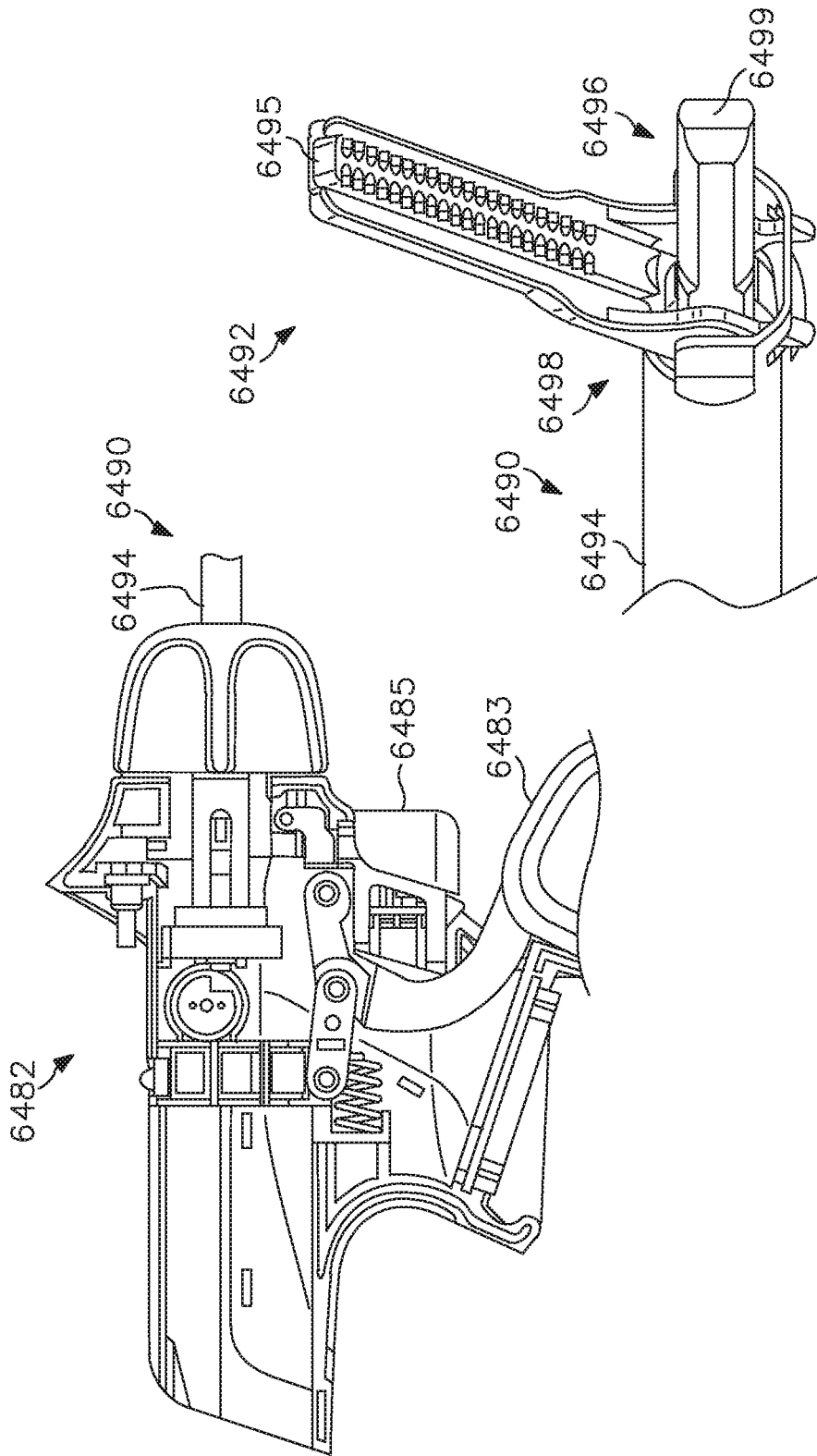

FIG. 48

FIG. 47

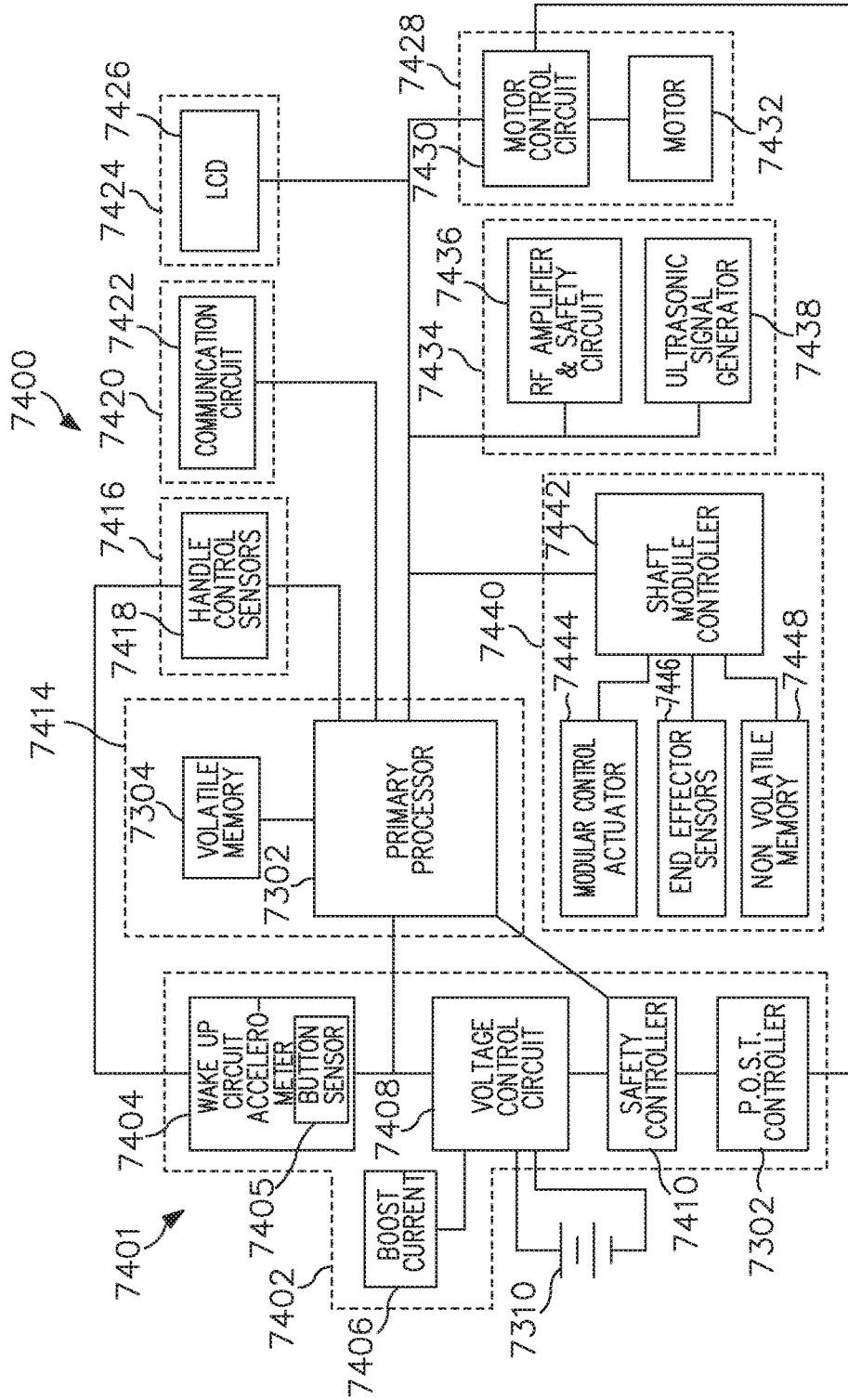

FIG. 49

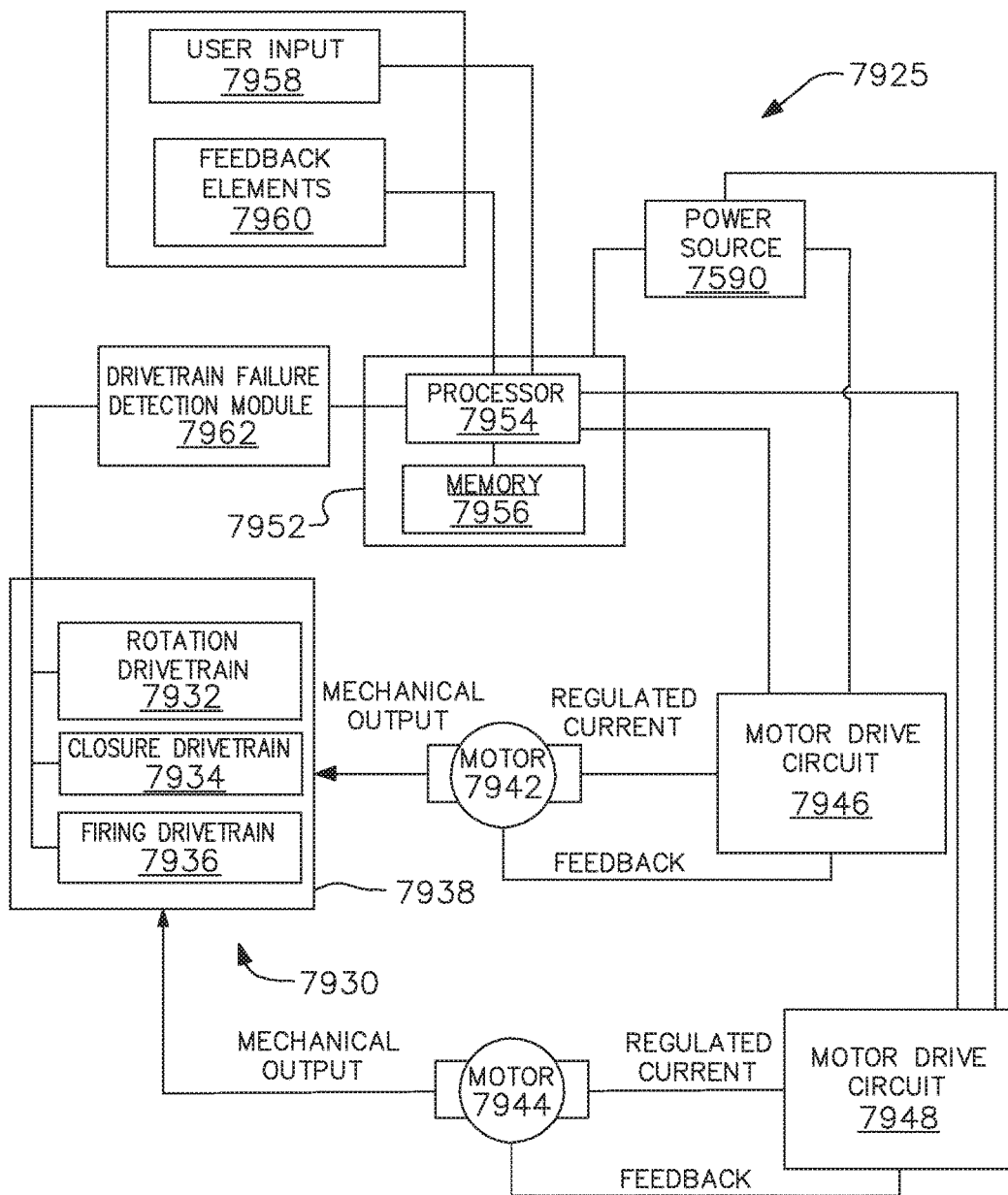

FIG. 50

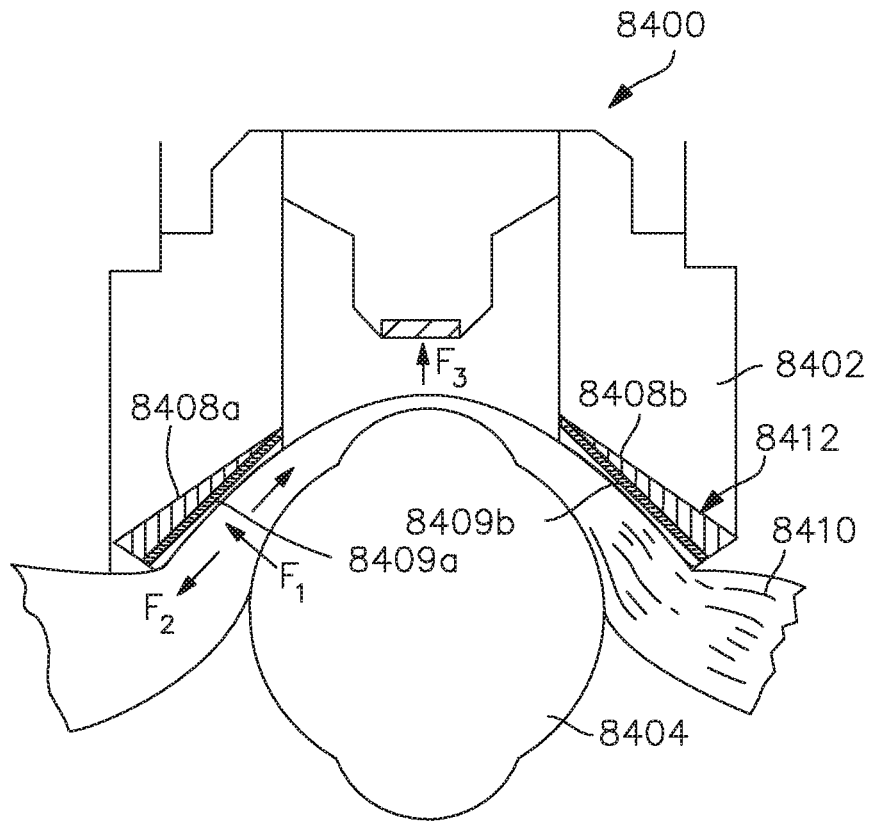

FIG. 51

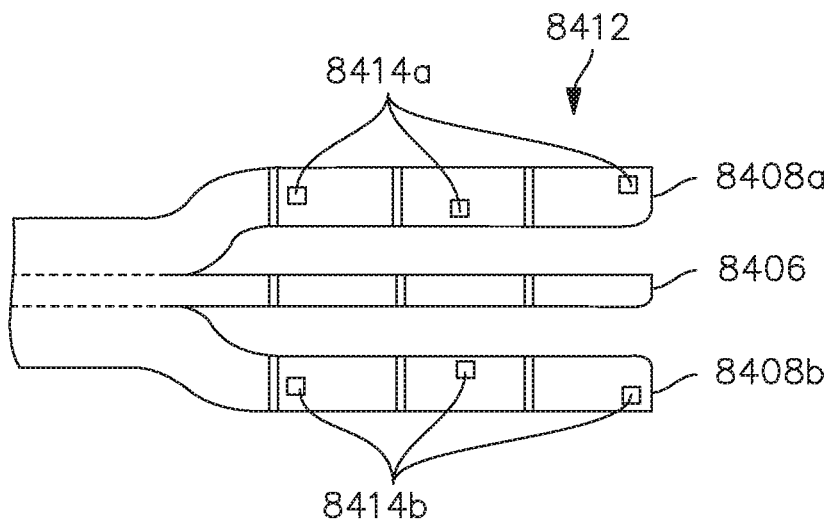

FIG. 52

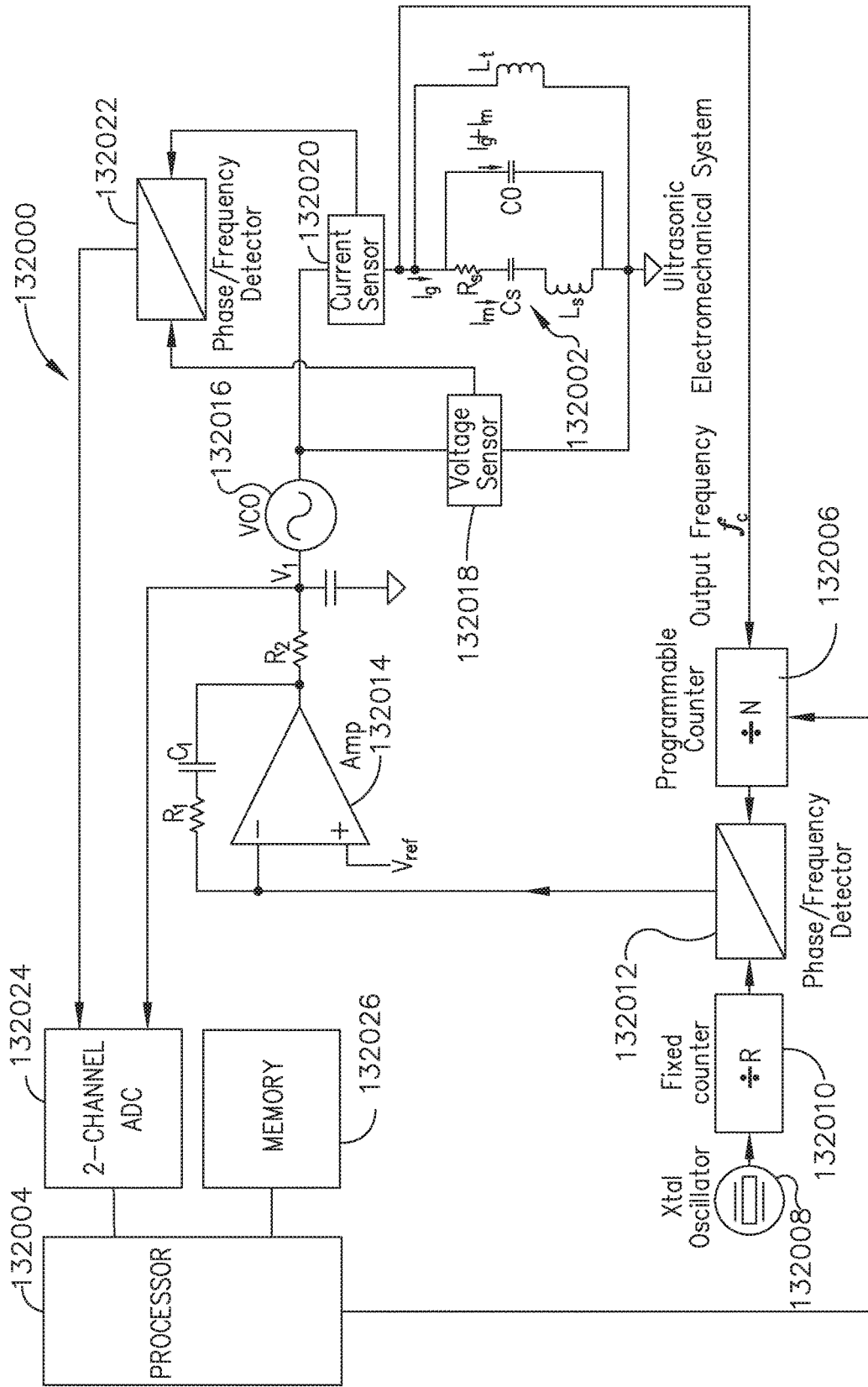

FIG. 53

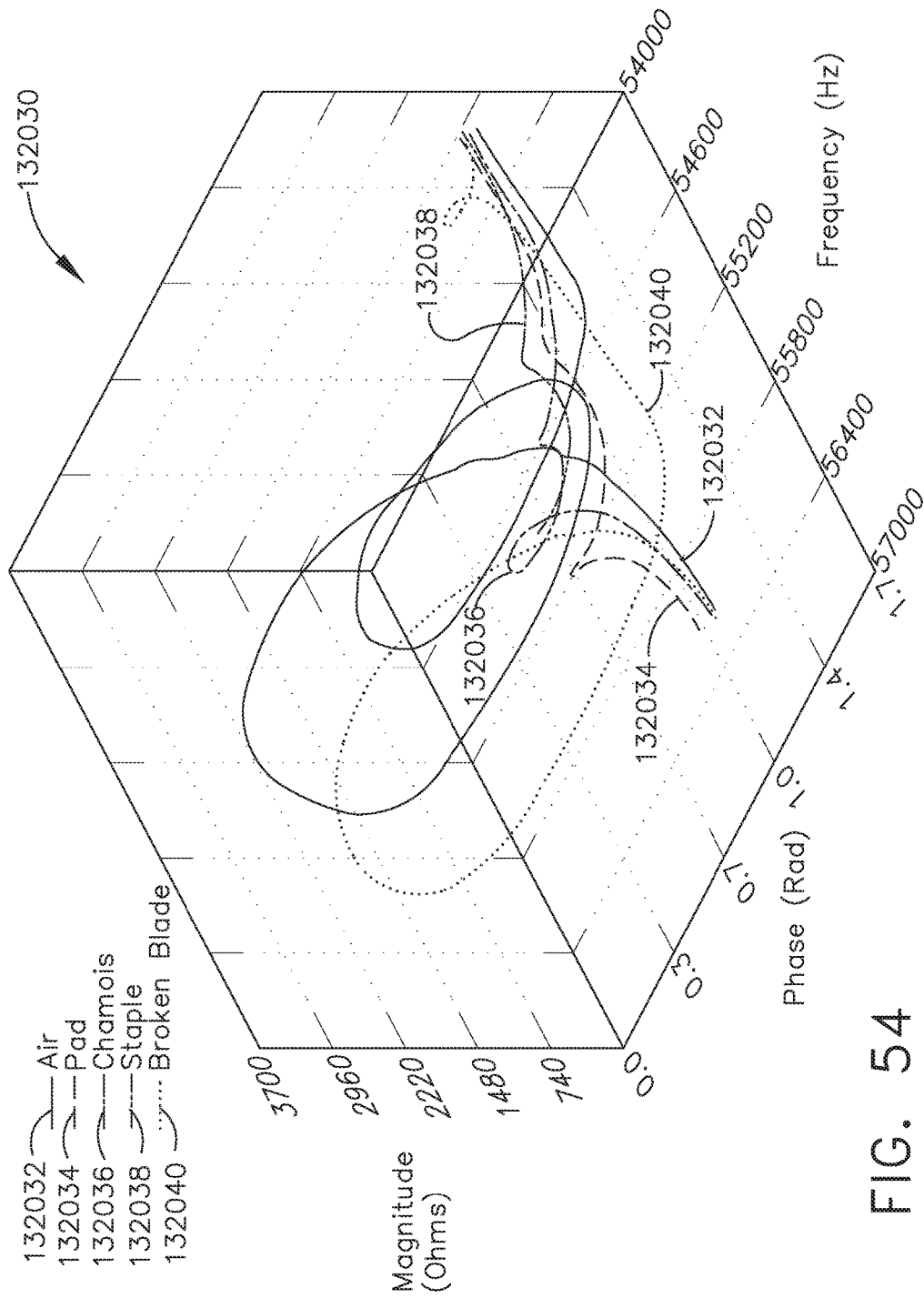

FIG. 54

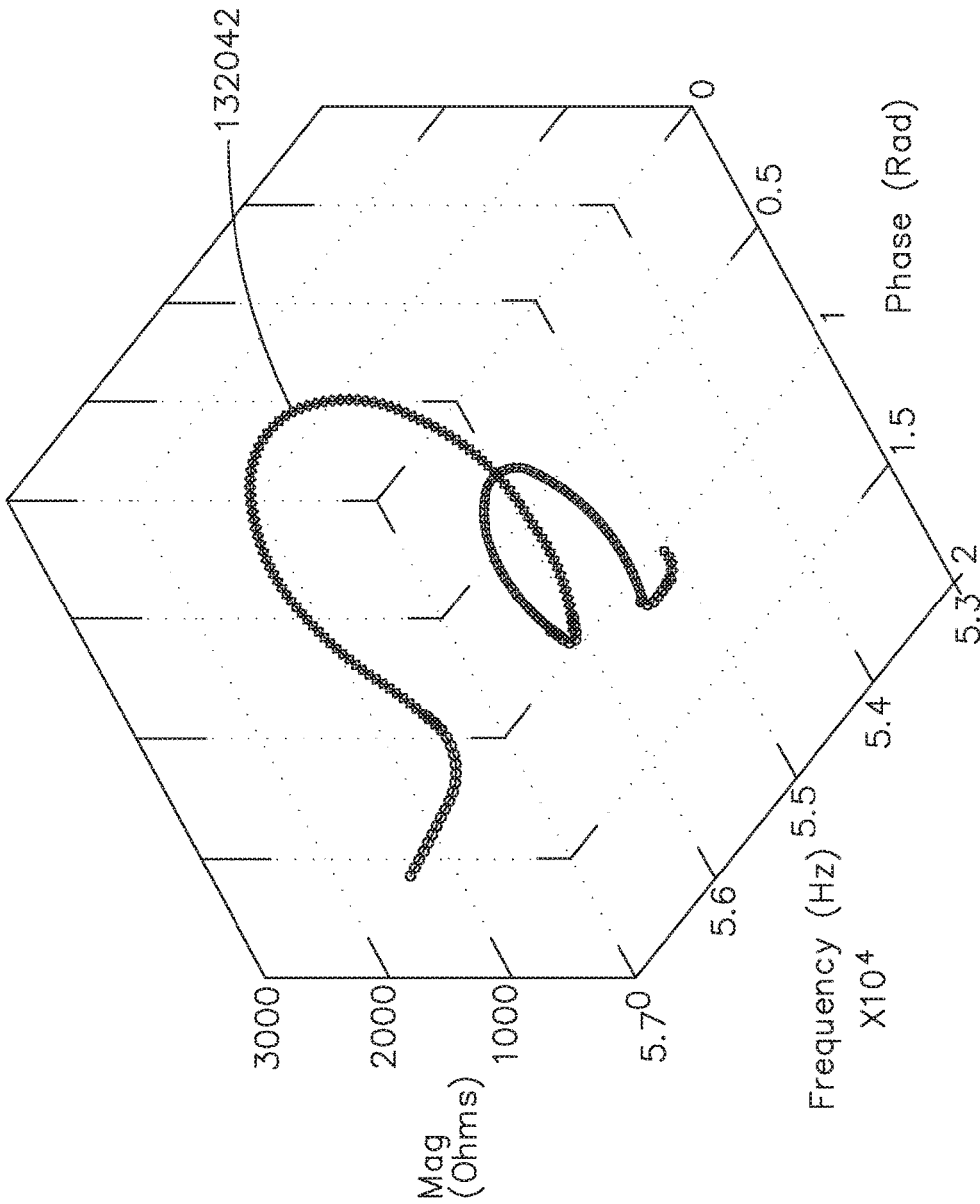

FIG. 55

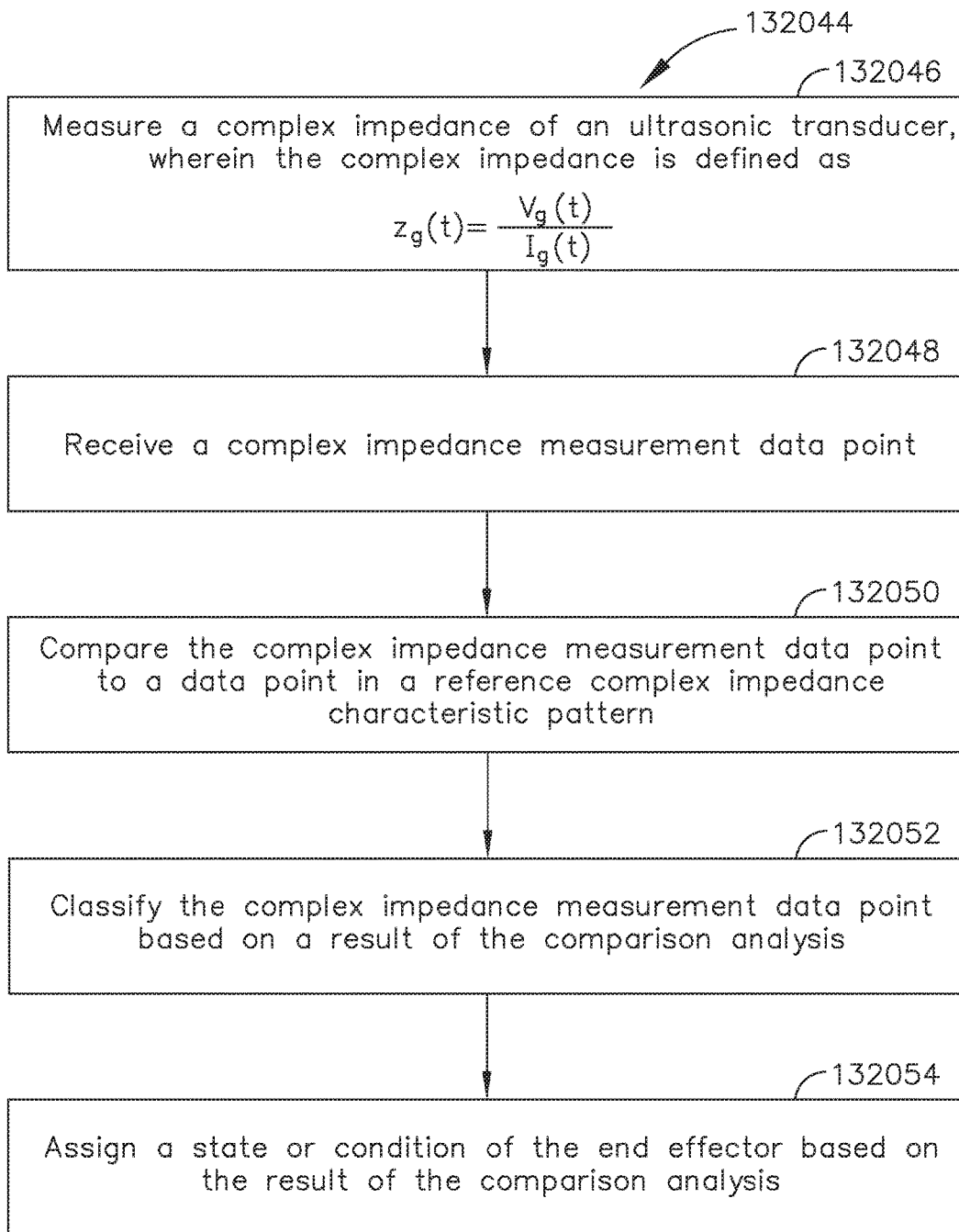

FIG. 56

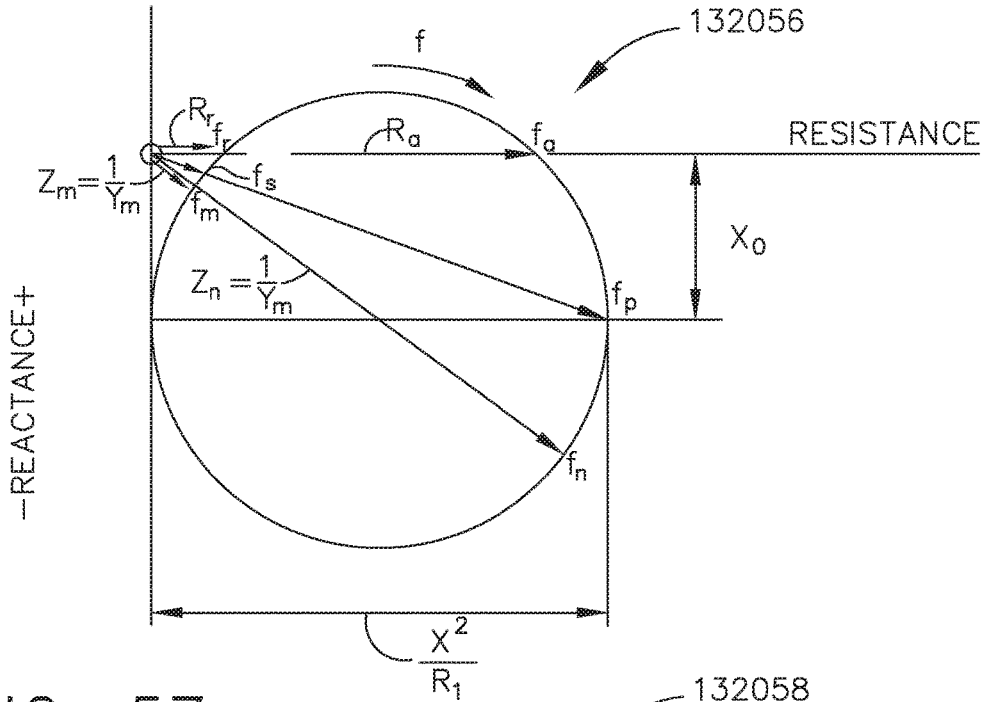

FIG. 57

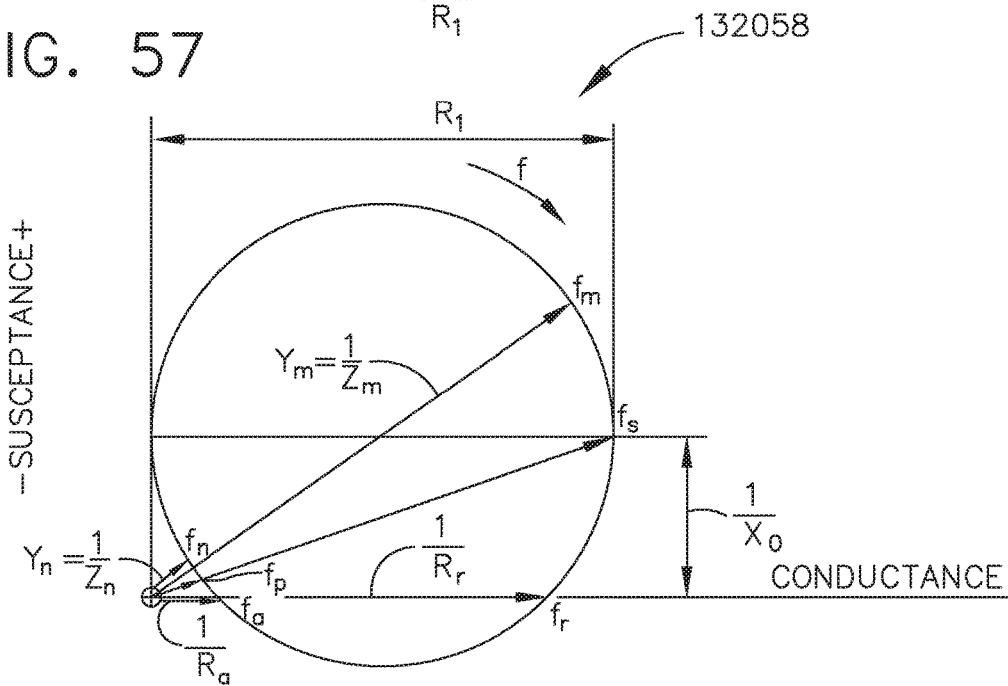

FIG. 58

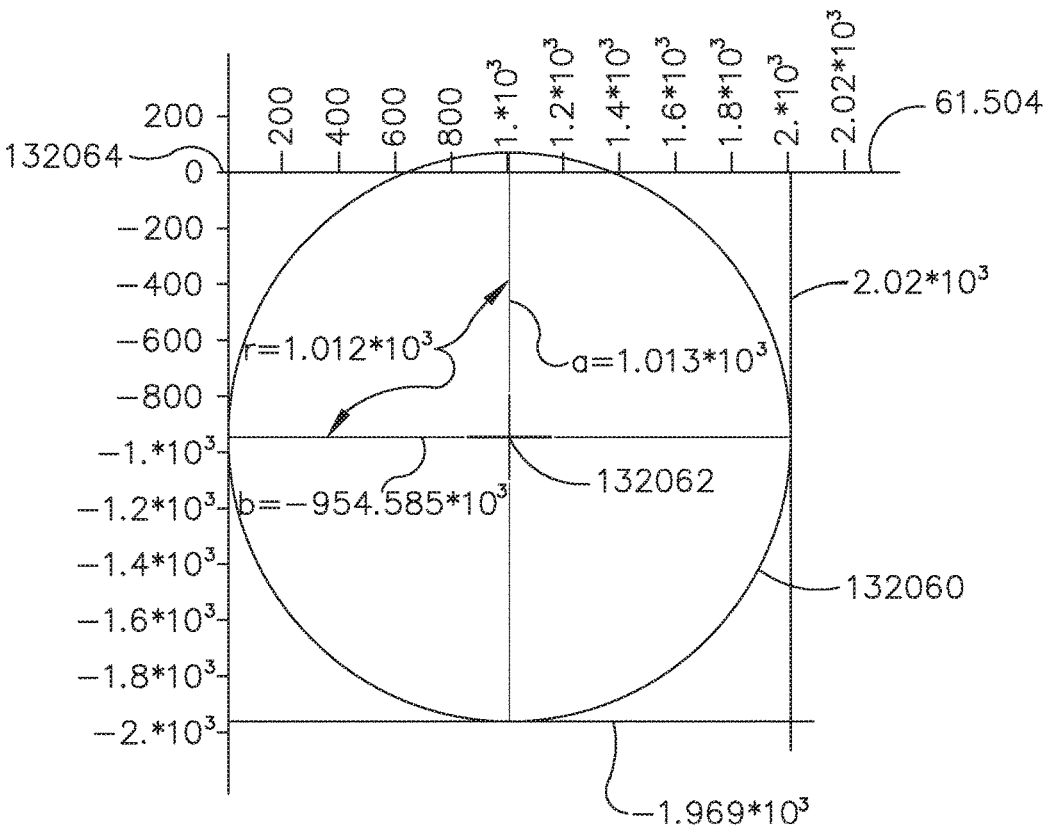

FIG. 59

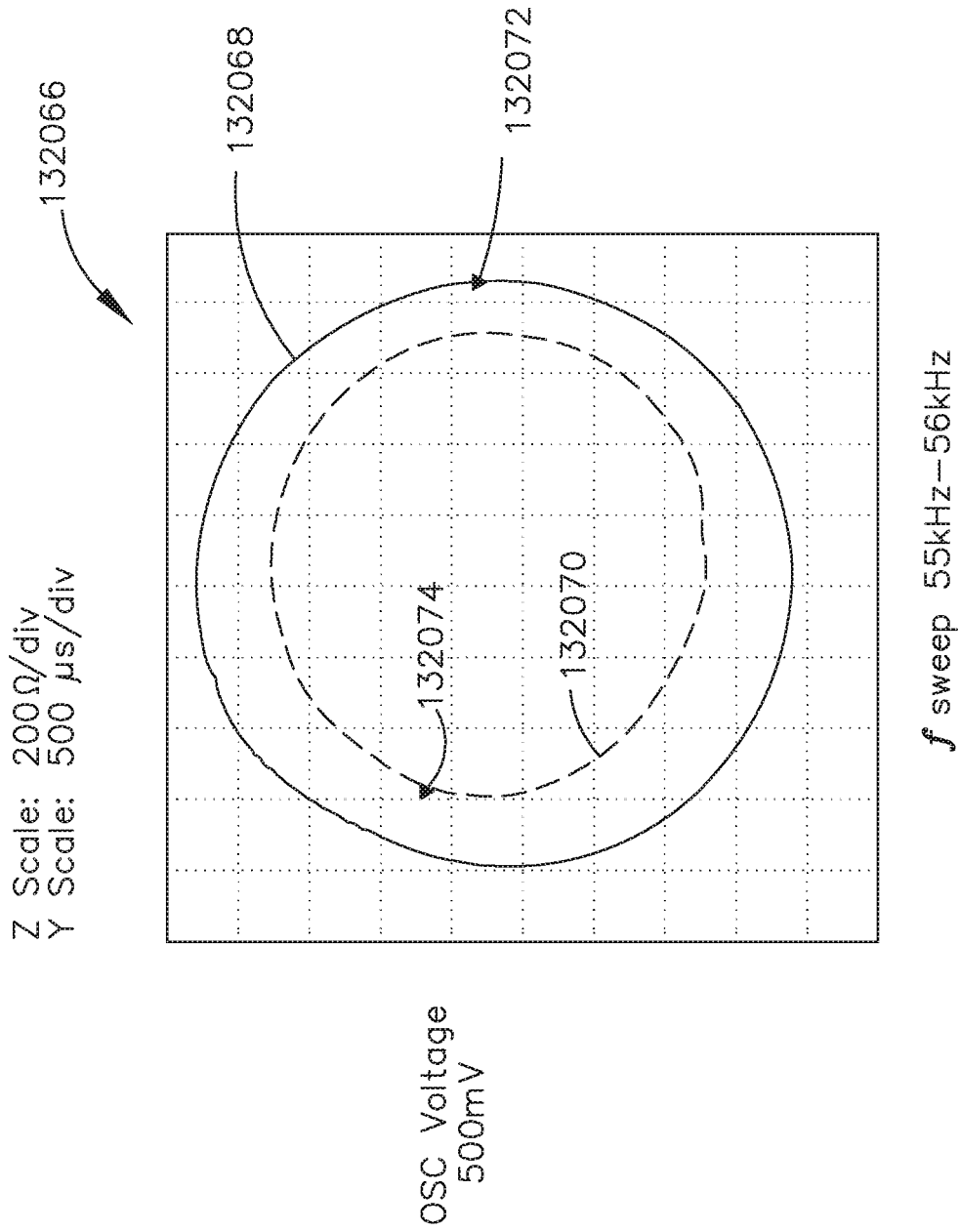
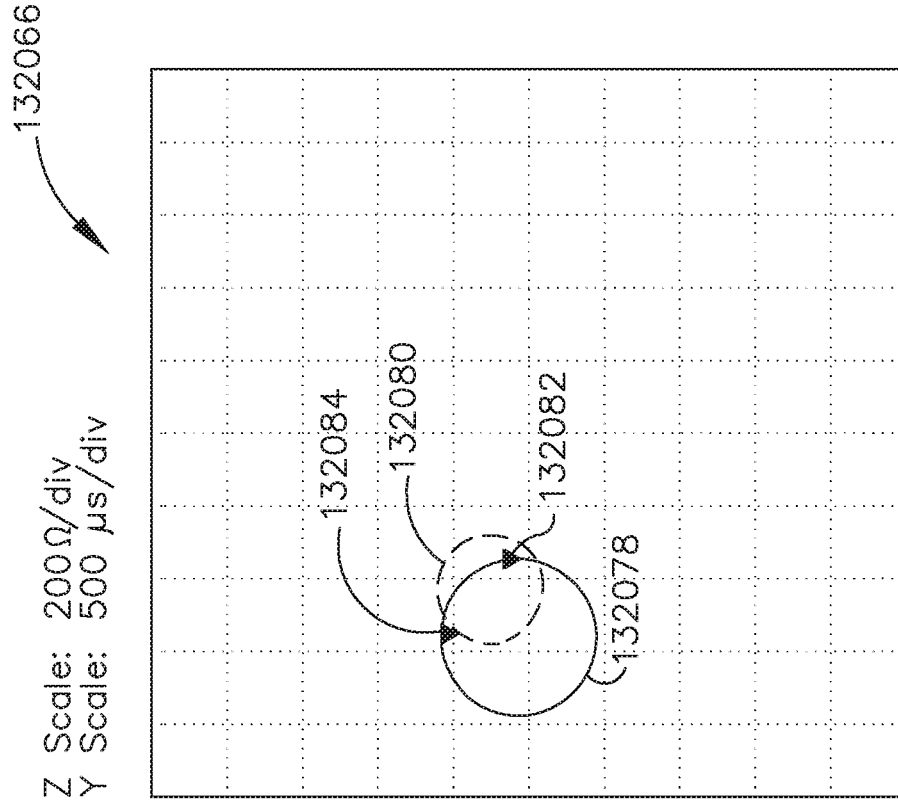

FIG. 60



OSC Voltage
500mV

f sweep 55kHz--56kHz

FIG. 61

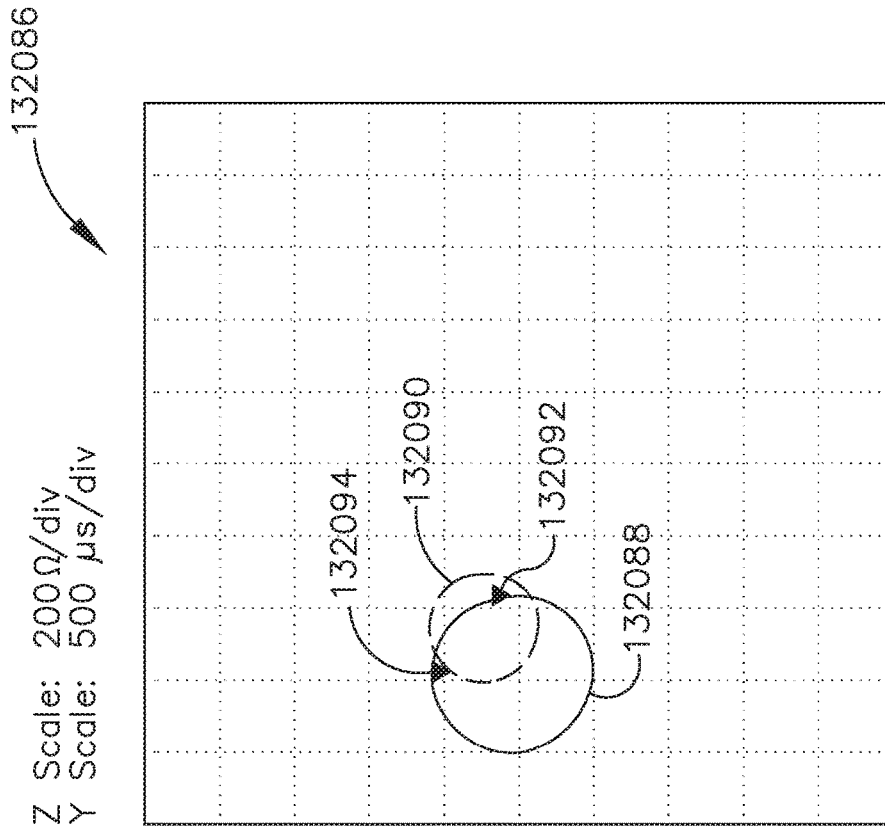

Z Scale: 200 Ω /div
Y Scale: 500 μ s/div

OSC Voltage
500mV

f sweep 55kHz--56kHz

FIG. 62

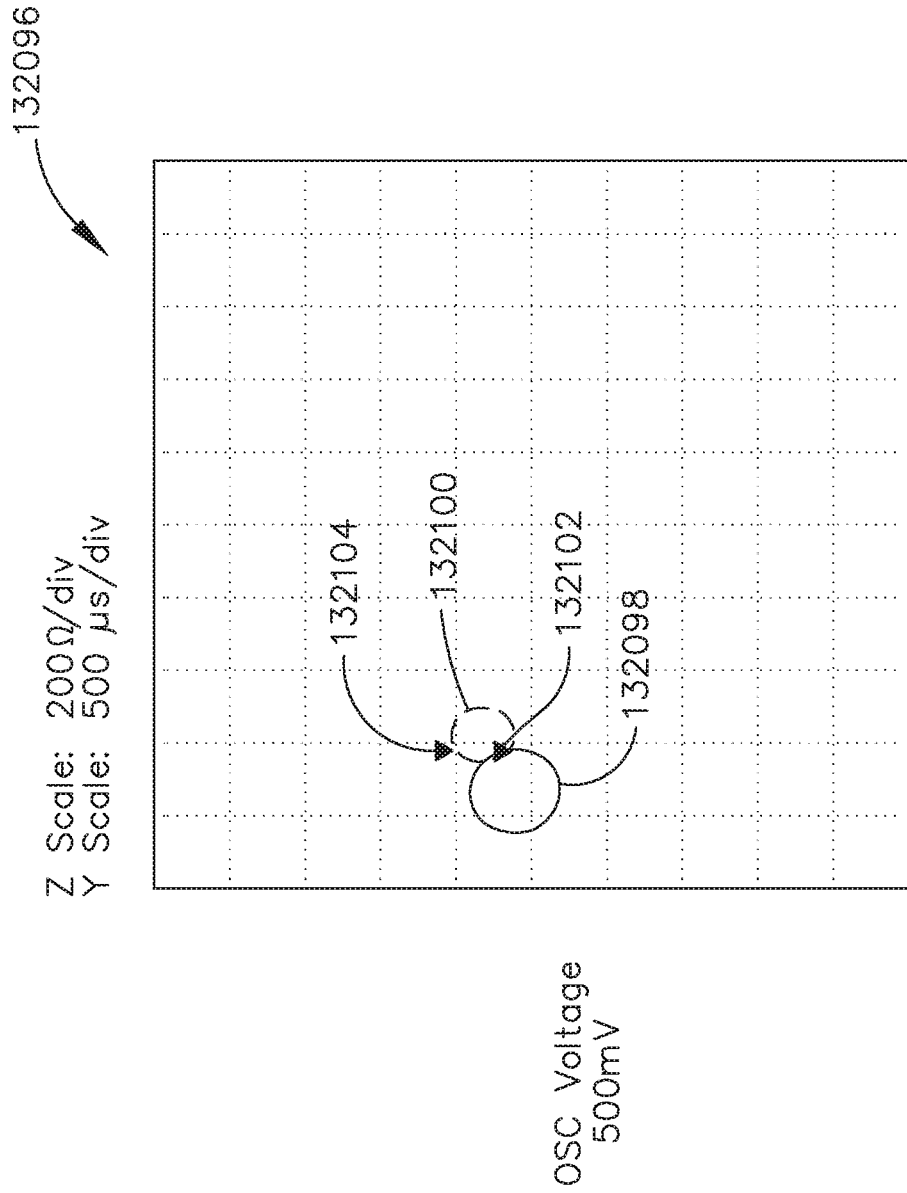

f sweep 55kHz--56kHz

FIG. 63

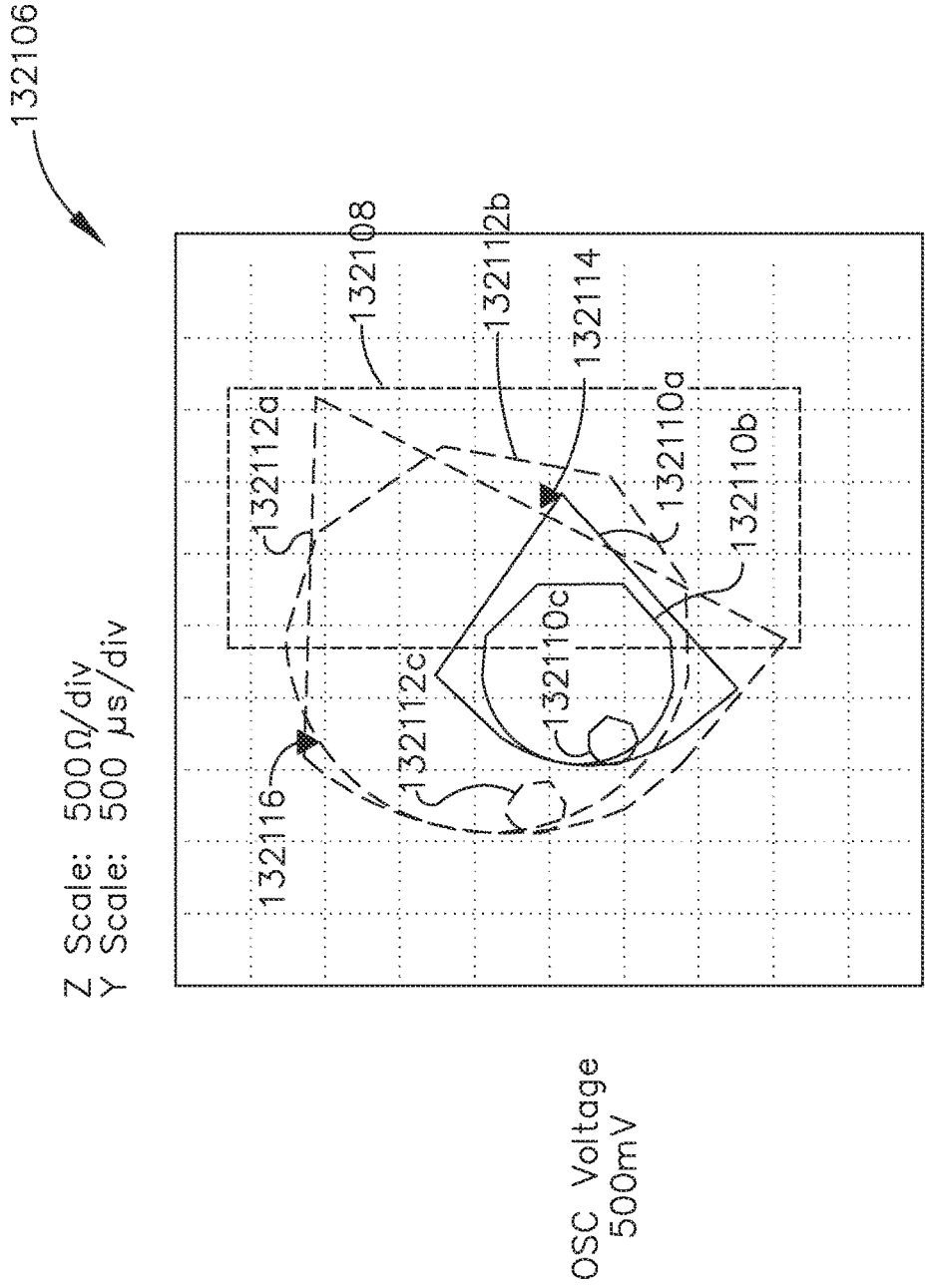

f sweep 48kHz-62kHz

FIG. 64

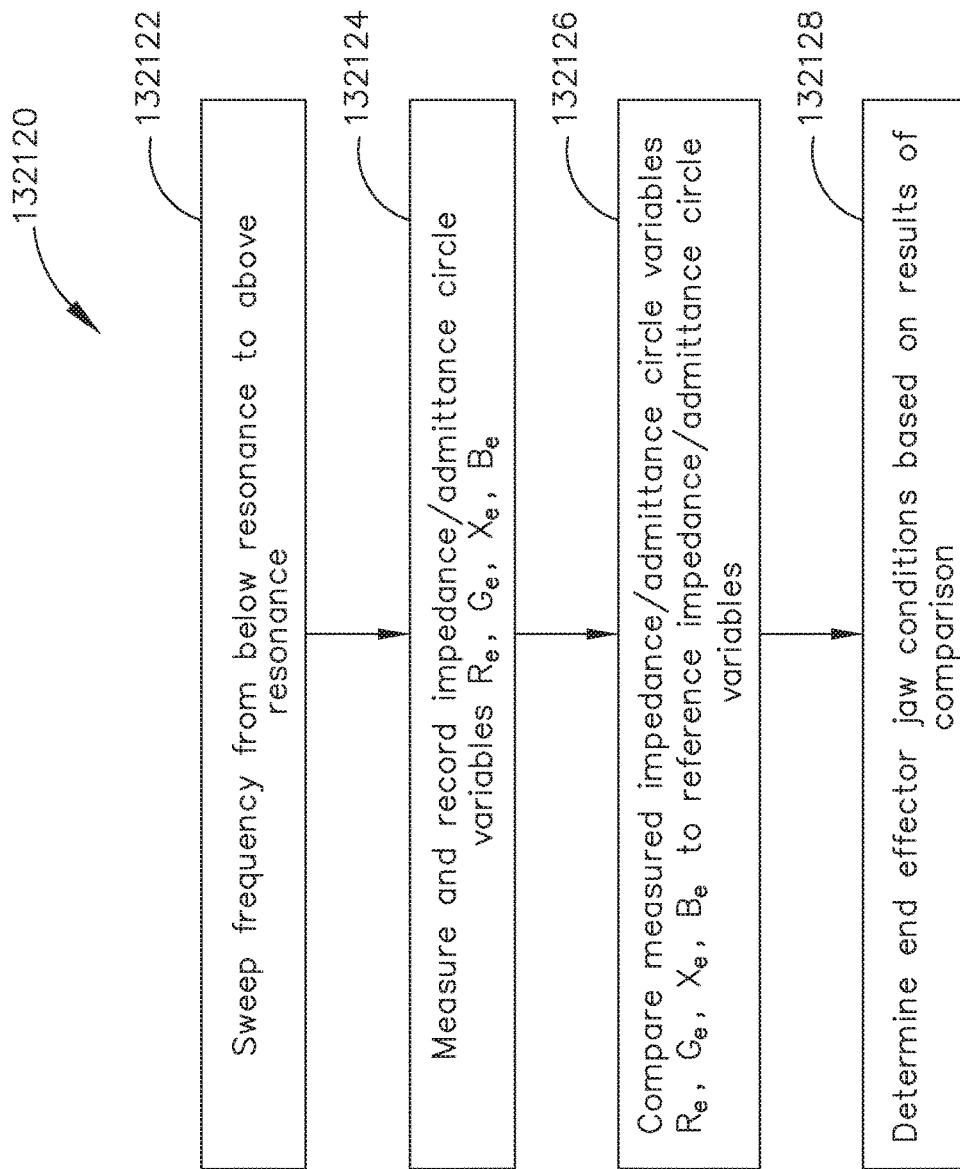

FIG. 65

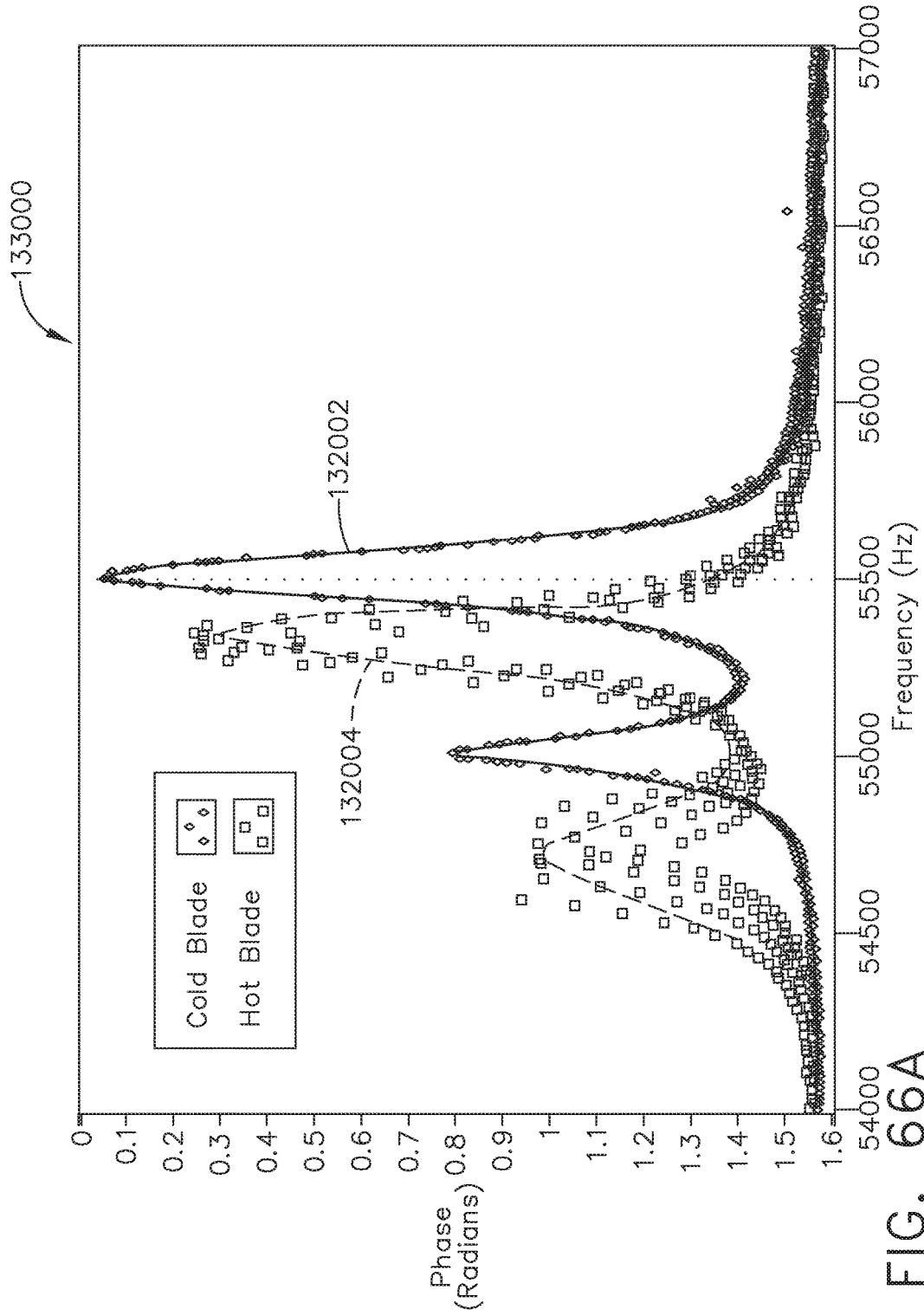

FIG. 66A

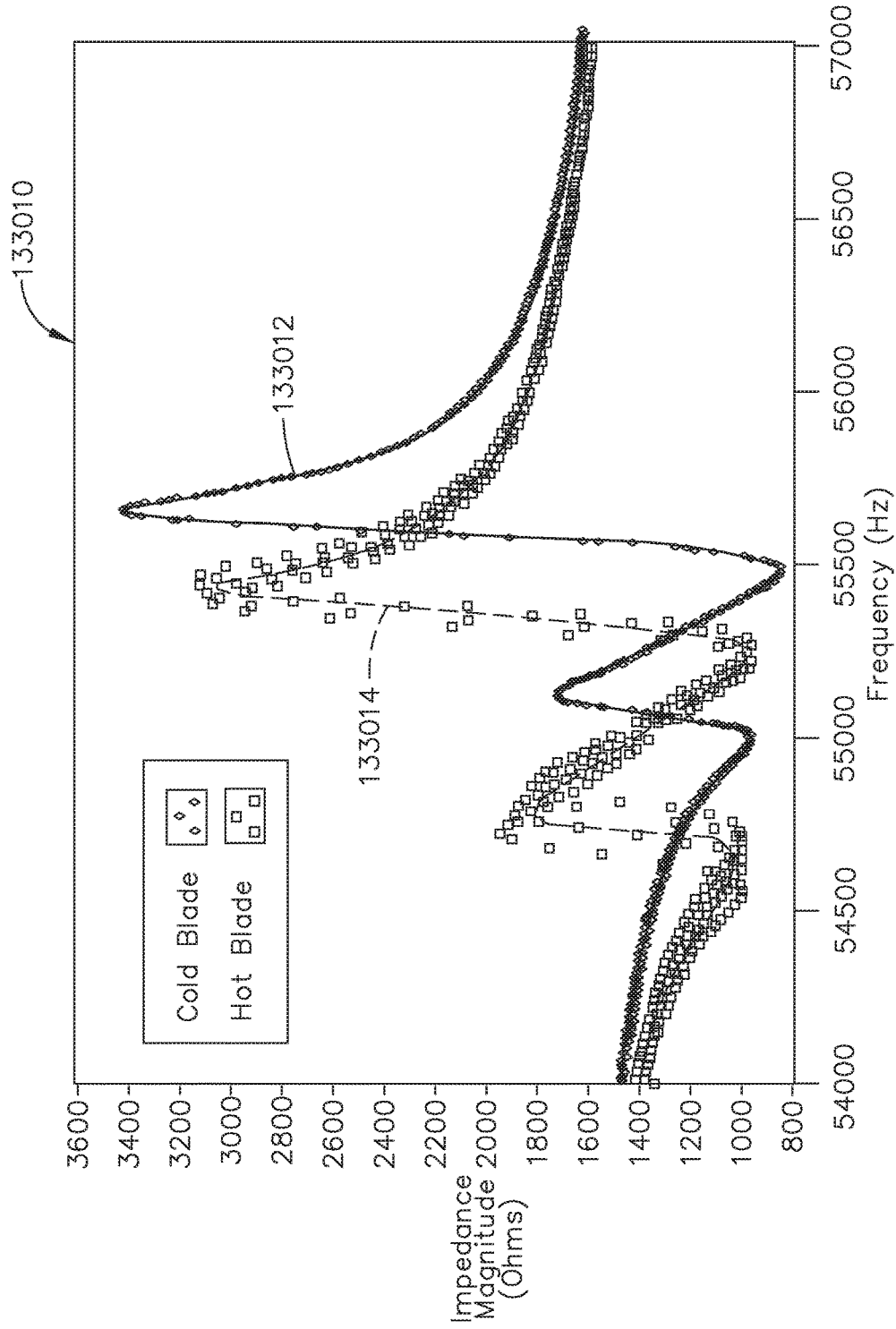

FIG. 66B

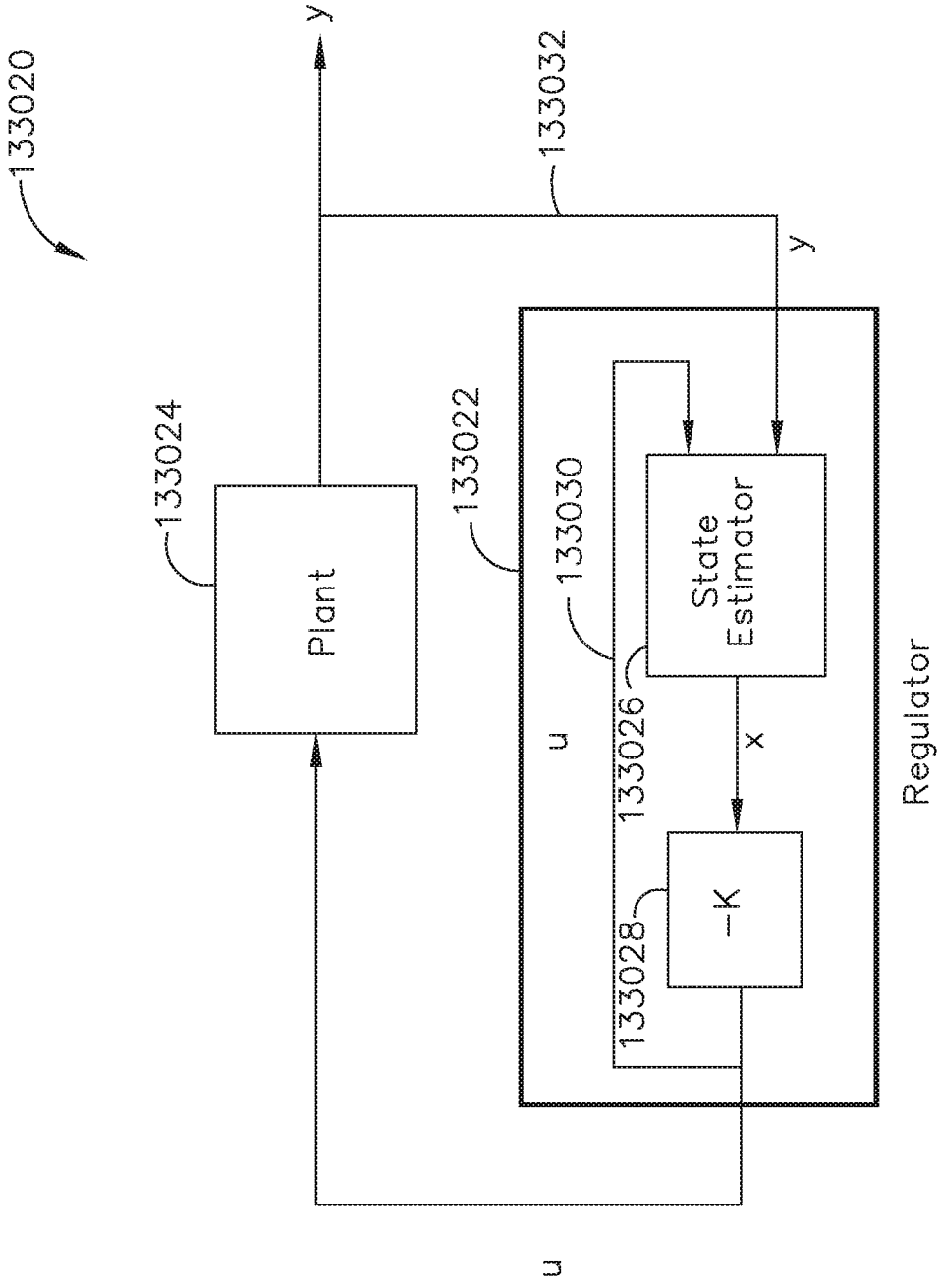

FIG. 67

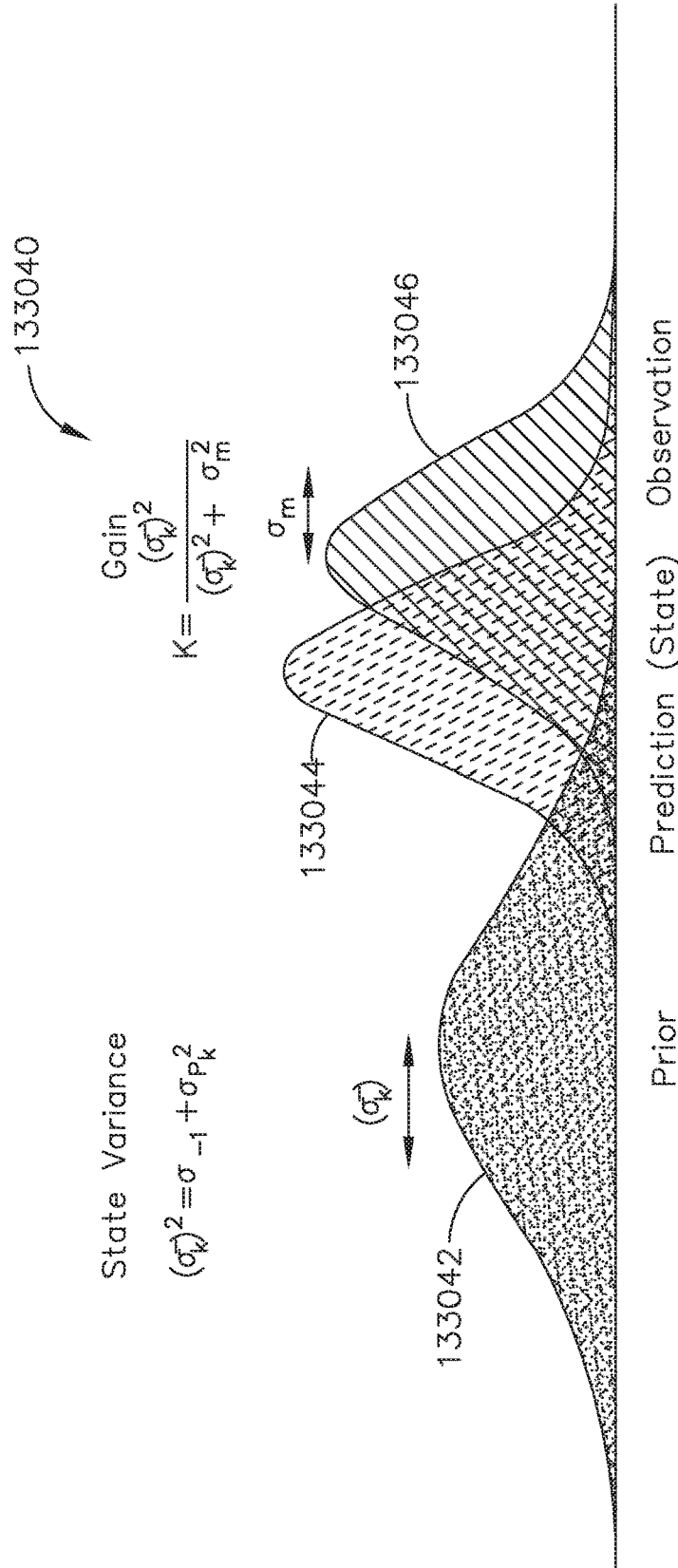

FIG. 68

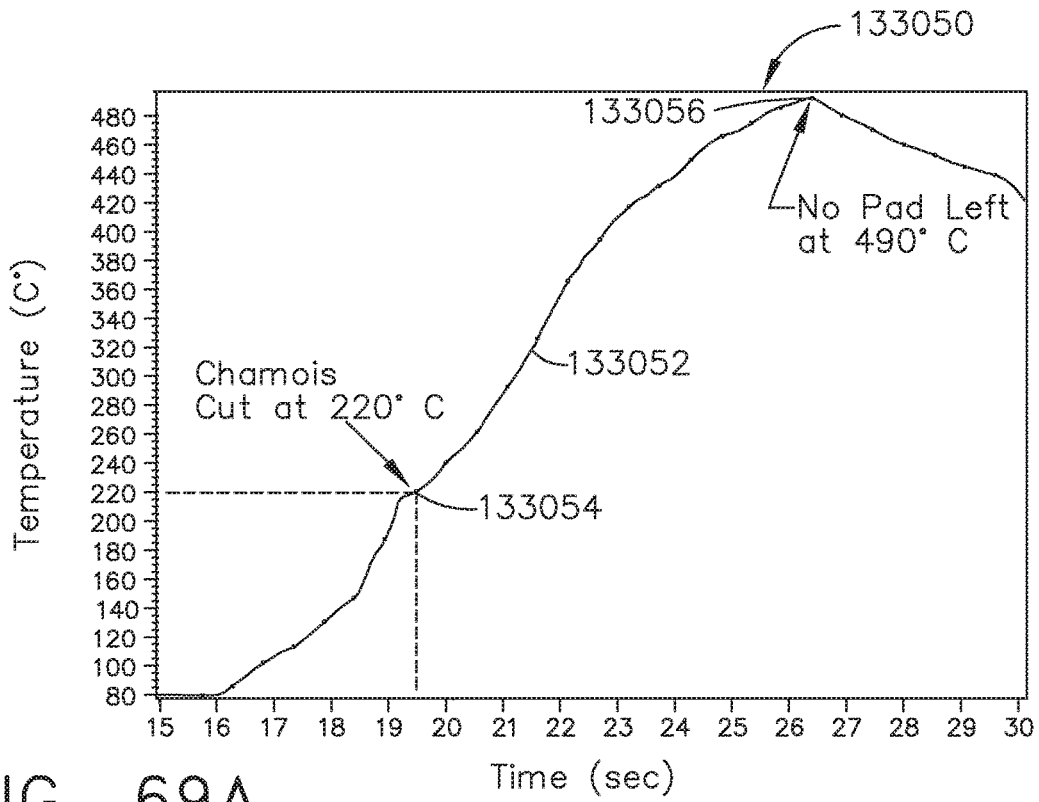

FIG. 69A

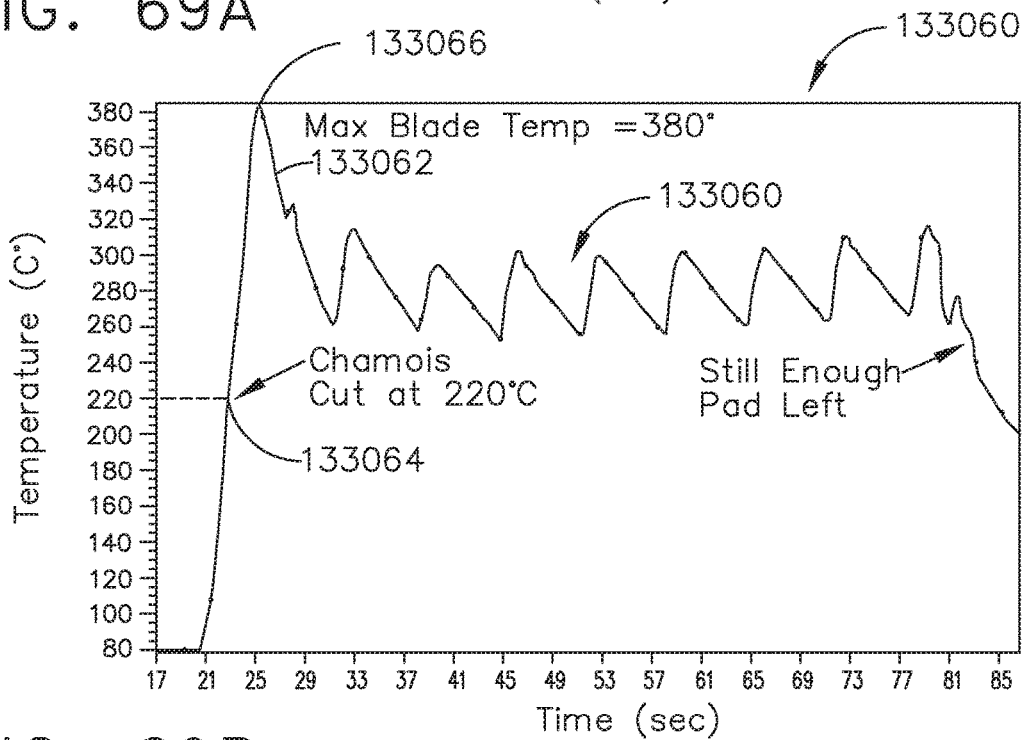

FIG. 69B

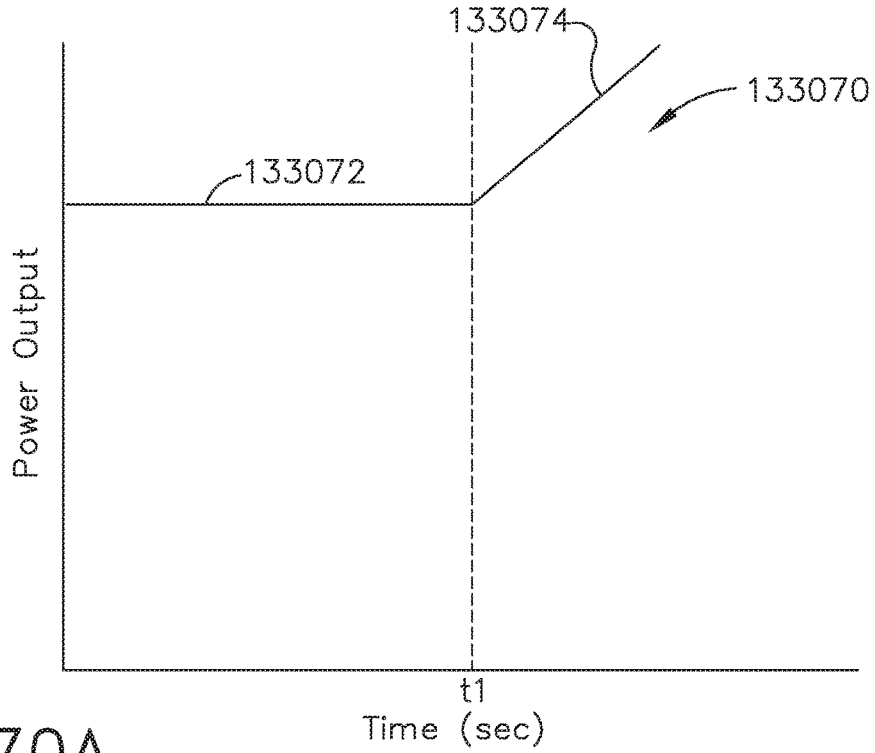

FIG. 70A

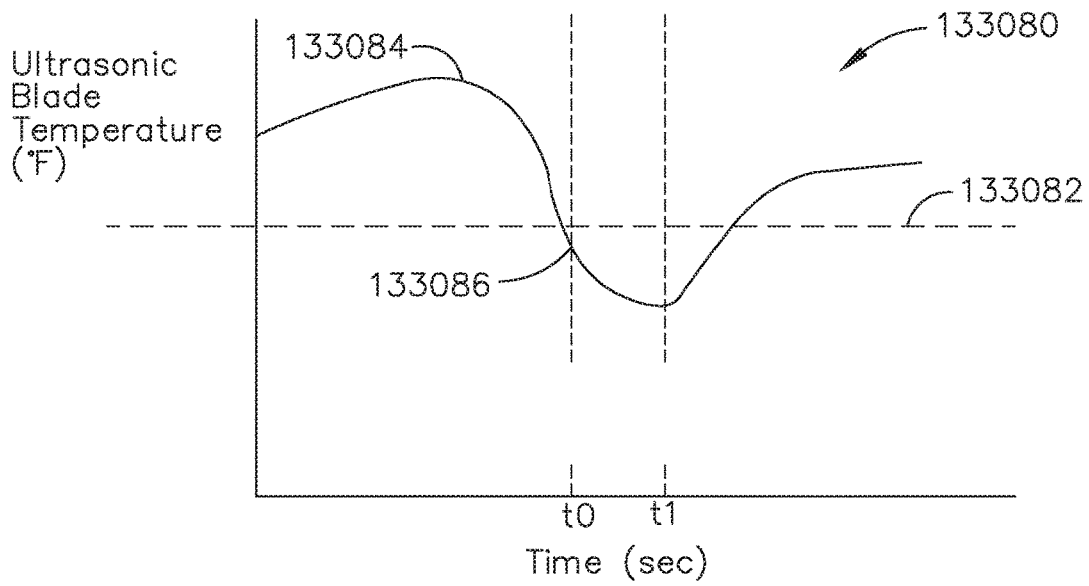

FIG. 70B

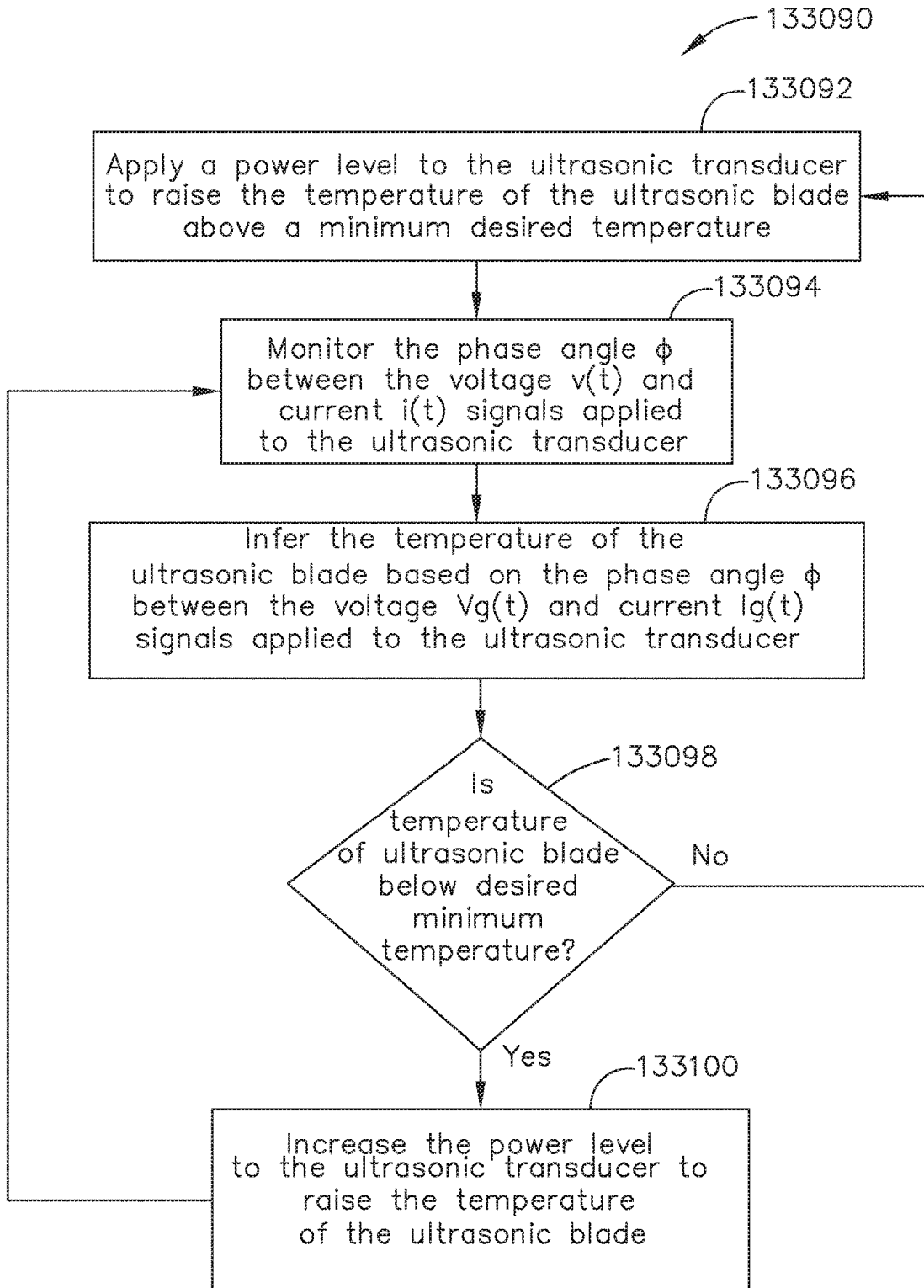

FIG. 71

WHAT THE HUB KNOWS	TYPE OF DATA	PROCEDURE STEP
THORACIC PROCEDURE	SELECT PATIENT DATA 5202	PULL ELECTRONIC MEDICAL RECORDS
NOT A WEDGE PROCEDURE	SCAN PRODUCTS 5204	SCAN INCOMING SUPPLIES
CONFIRM PATIENT	UNIQUE ID 5206	SCAN PATIENT BAND
VATS	SMOKE EVAC. DATA INSUFFLATION DATA SCOPE DATA 5208	TURN ON HUB AUXILIARY EQUIPMENT
CONFIRM PATIENT IS IN O.R.	EKG DATA 5210	ATTACH EKG
PATIENT UNDER	EKG, BP AND VENTILATOR DATA 5212	INDUCE ANESTHESIA
PROCEDURE BEGINS	VENTILATOR DATA 5214	COLLAPSE LUNG
CONFIRM LOBECTOMY vs. SEGMENTECTOMY LAP PORTION STARTS	SCOPE DATA 5216	SCOPE IMAGE
WHAT THE HUB KNOWS	TYPE OF DATA	PROCEDURE STEP
DISSECT TO MOBILIZE LUNG	GENERATOR DATA 5218	DISSECTION
LIGATE ARTERY & VEIN	STAPLER DATA 5220	LIGATION
TRANSECT PARENCHYMA	STAPLER & CARTRIDGE DATA 5222	SEGMENTECTOMY
DISSECT NODES LEAK TEST	GENERATOR DATA 5224	NODE DISSECTION
PATIENT EMERGENCE	VENTILATOR DATA 5226	REVERSE ANESTHESIA
PATIENT TRANSFER TO RECOVERY ROOM	LOSS OF EKG DATA LOSS OF BP DATA 5228	REMOVE MONITORS

FIG. 72

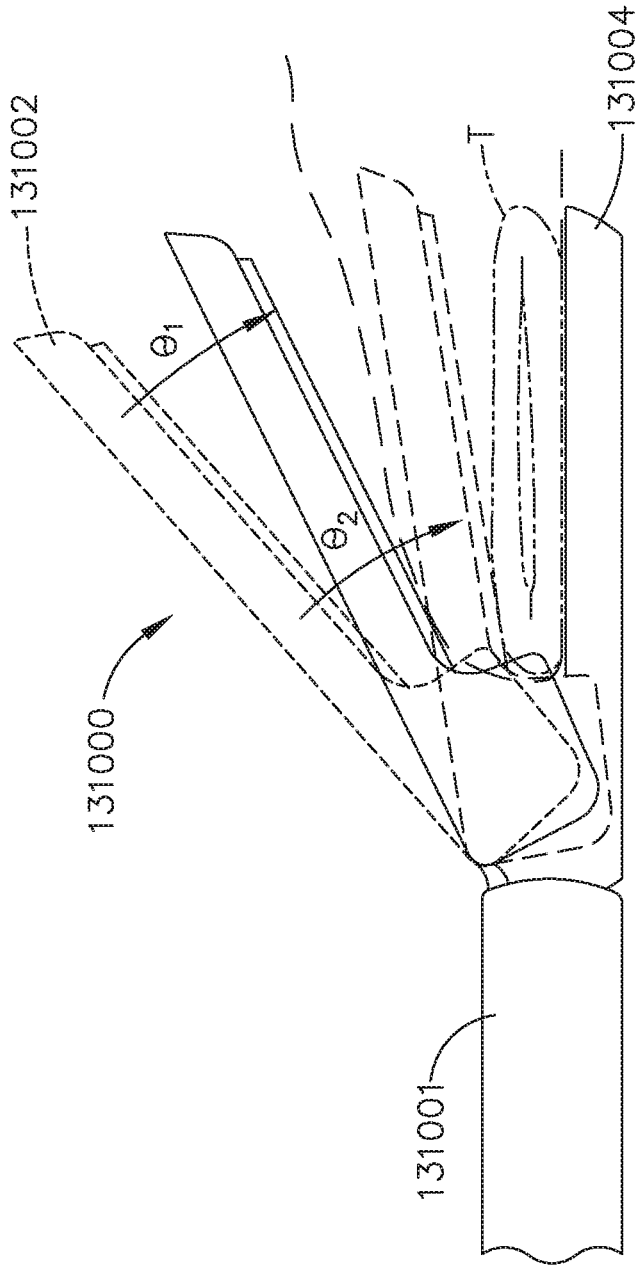

FIG. 73

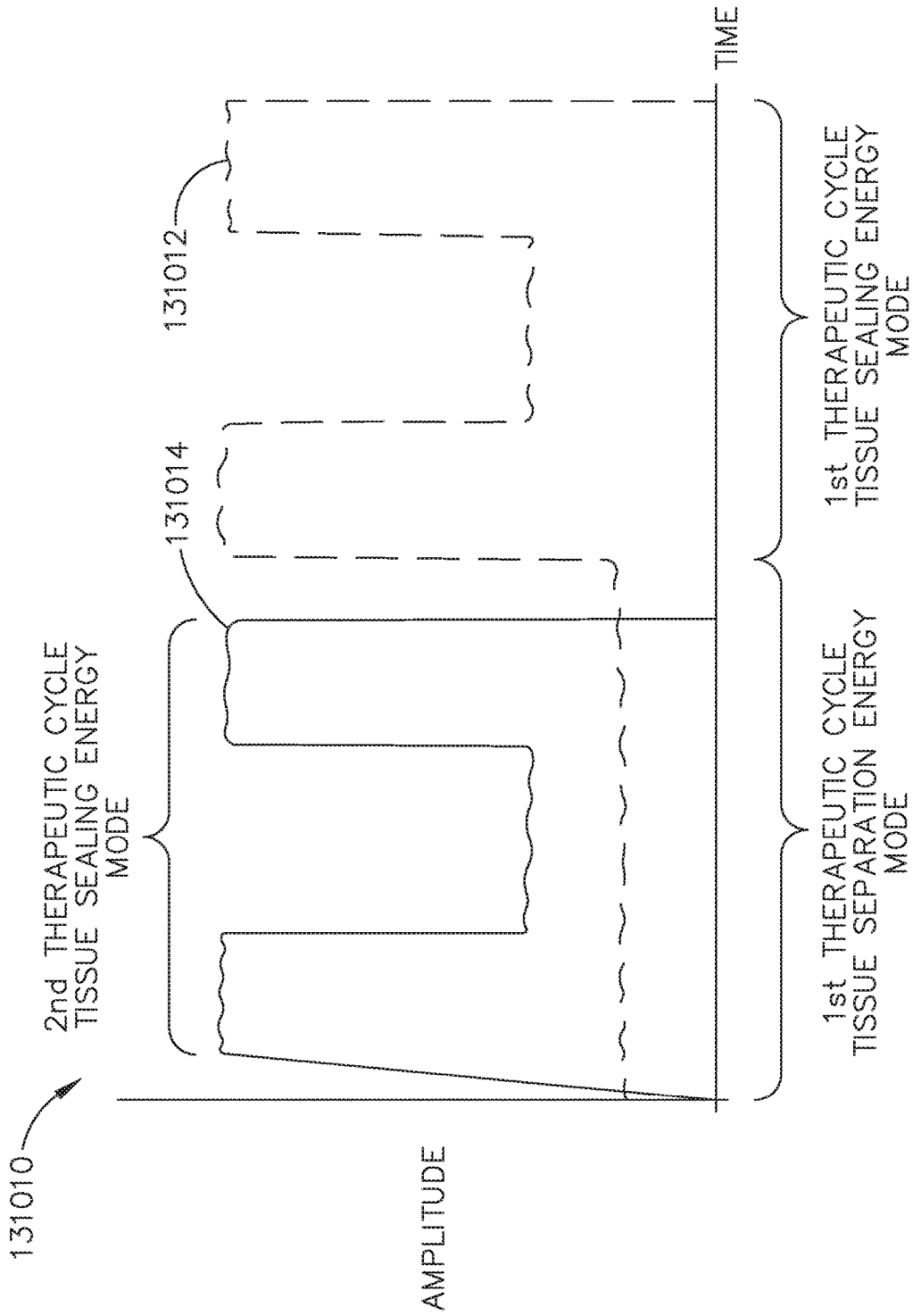

FIG. 74

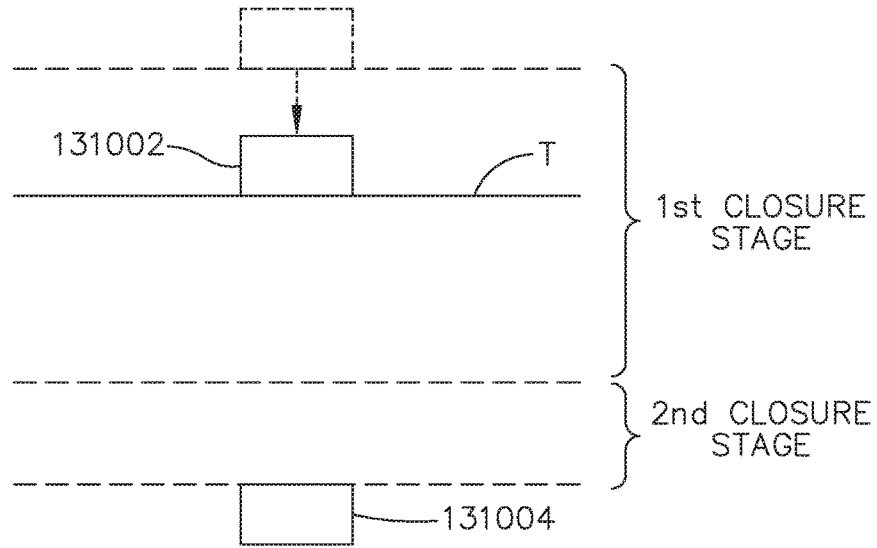

FIG. 75A

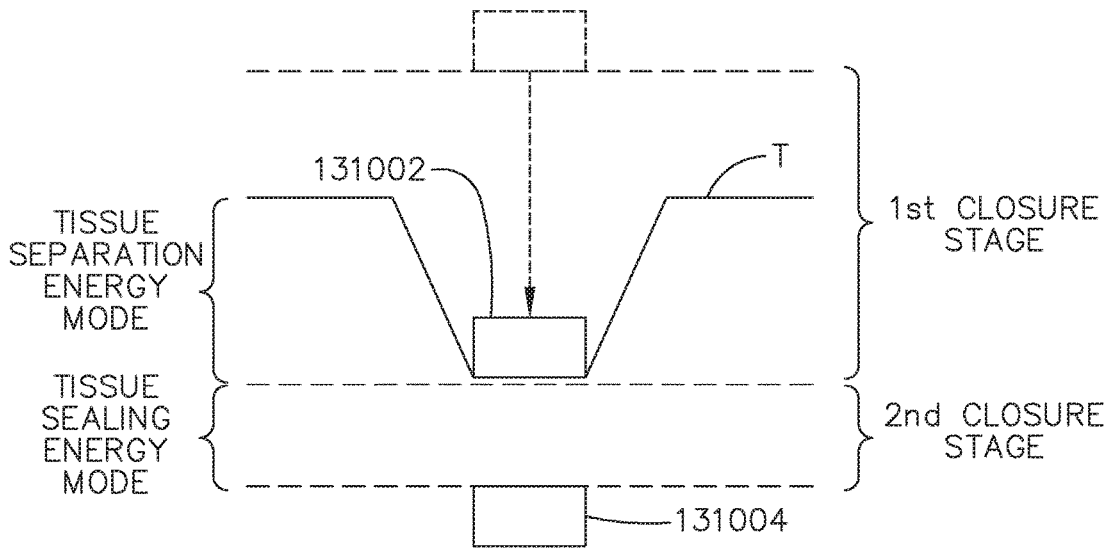

FIG. 75B

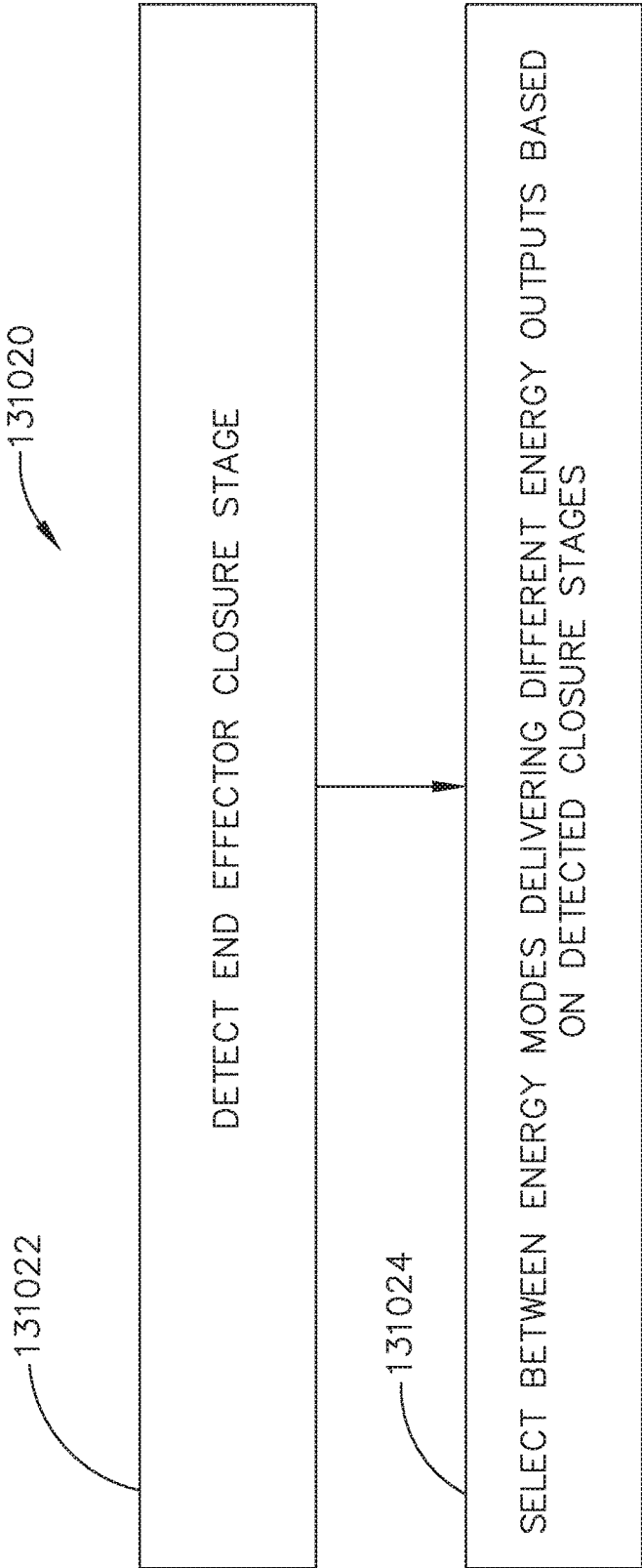

FIG. 76

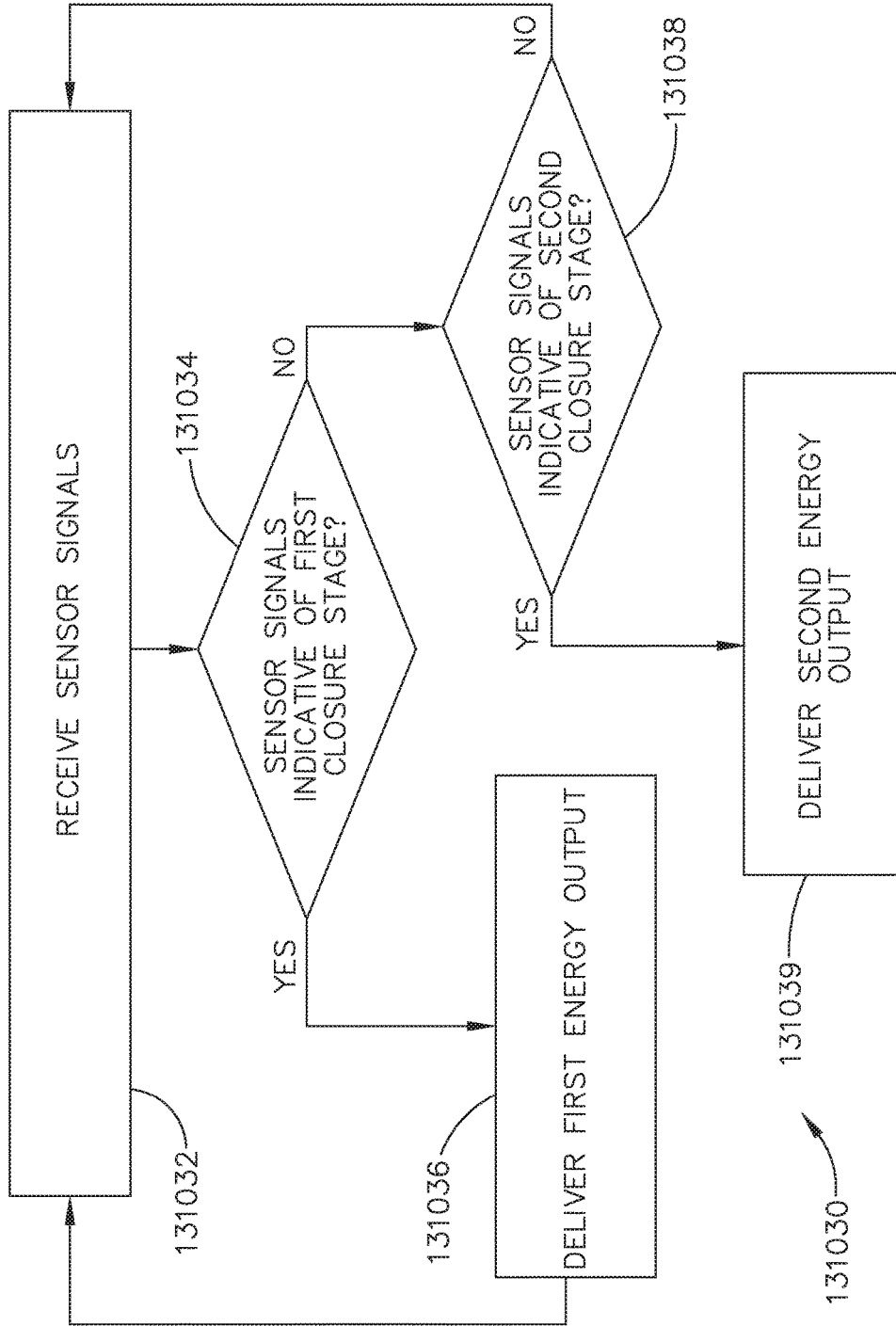
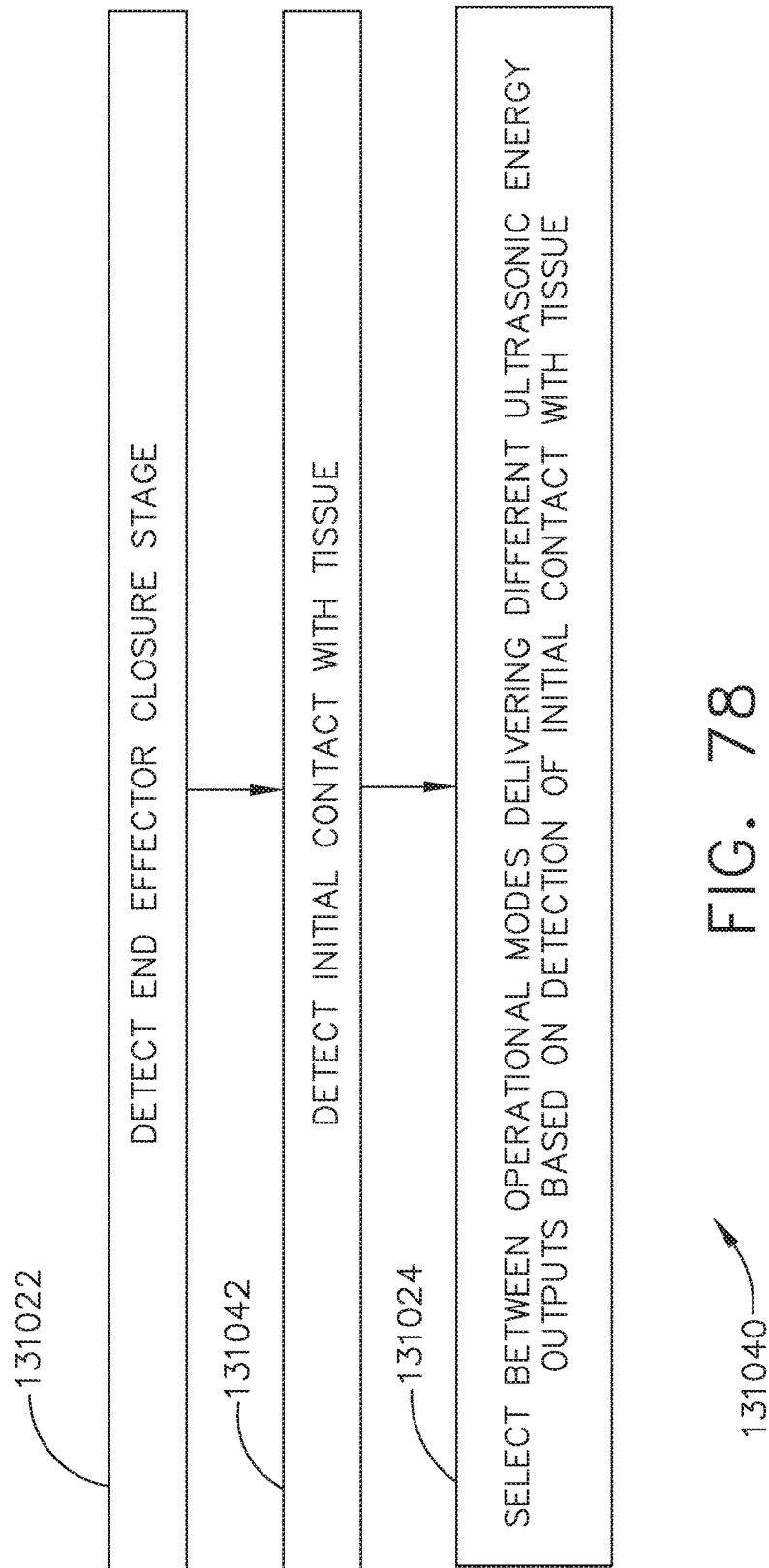

FIG. 77



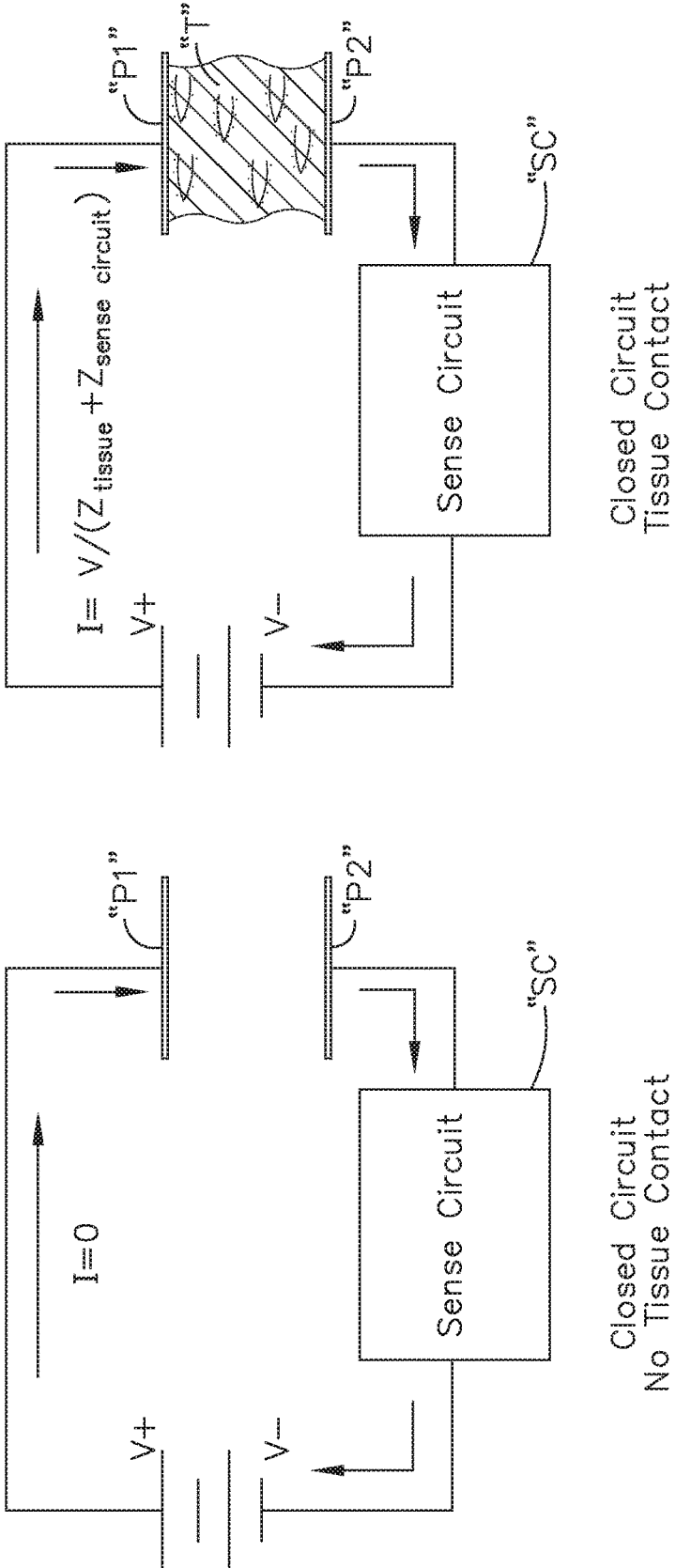

FIG. 78A

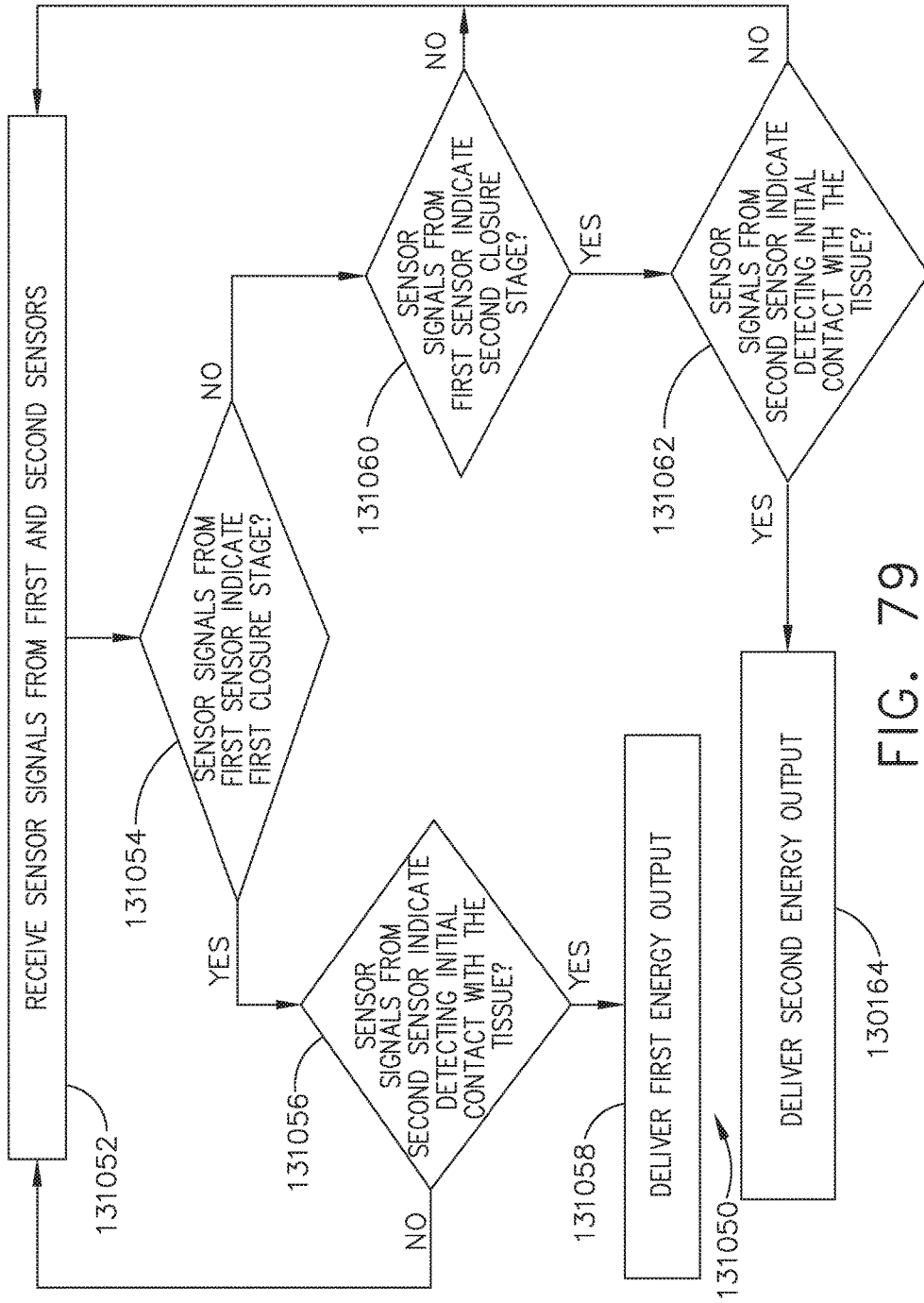

FIG. 79

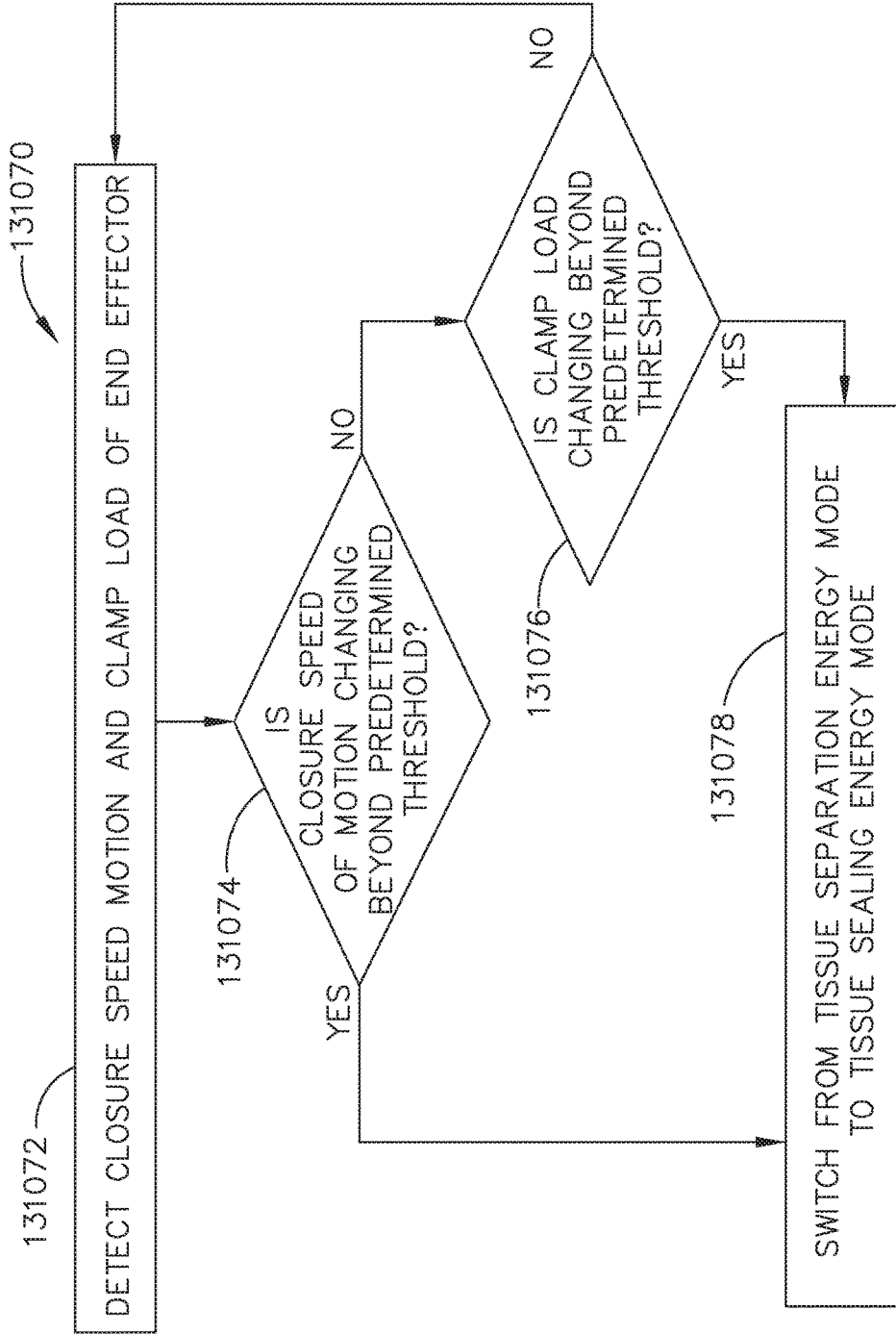

FIG. 81

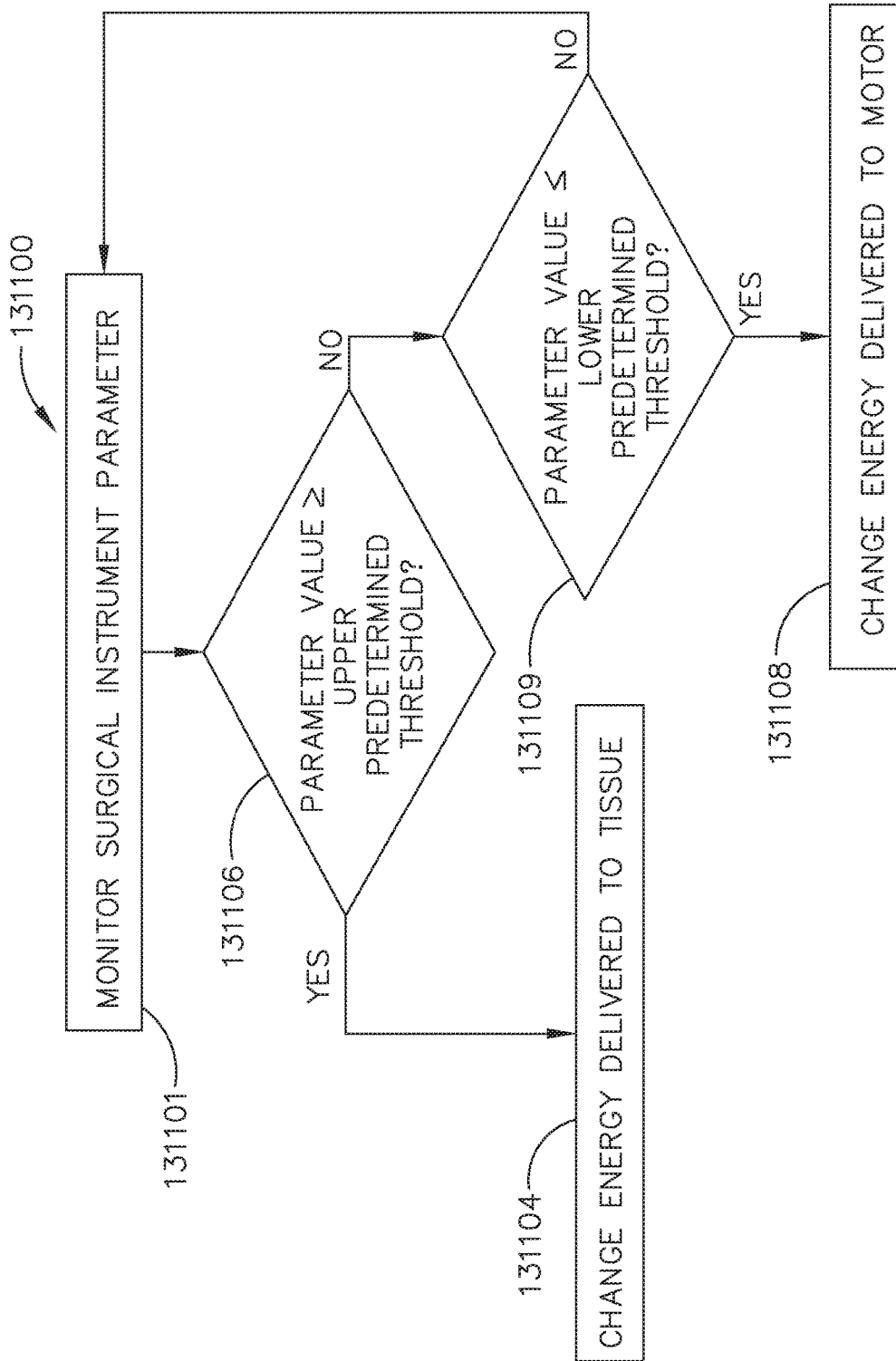

FIG. 82

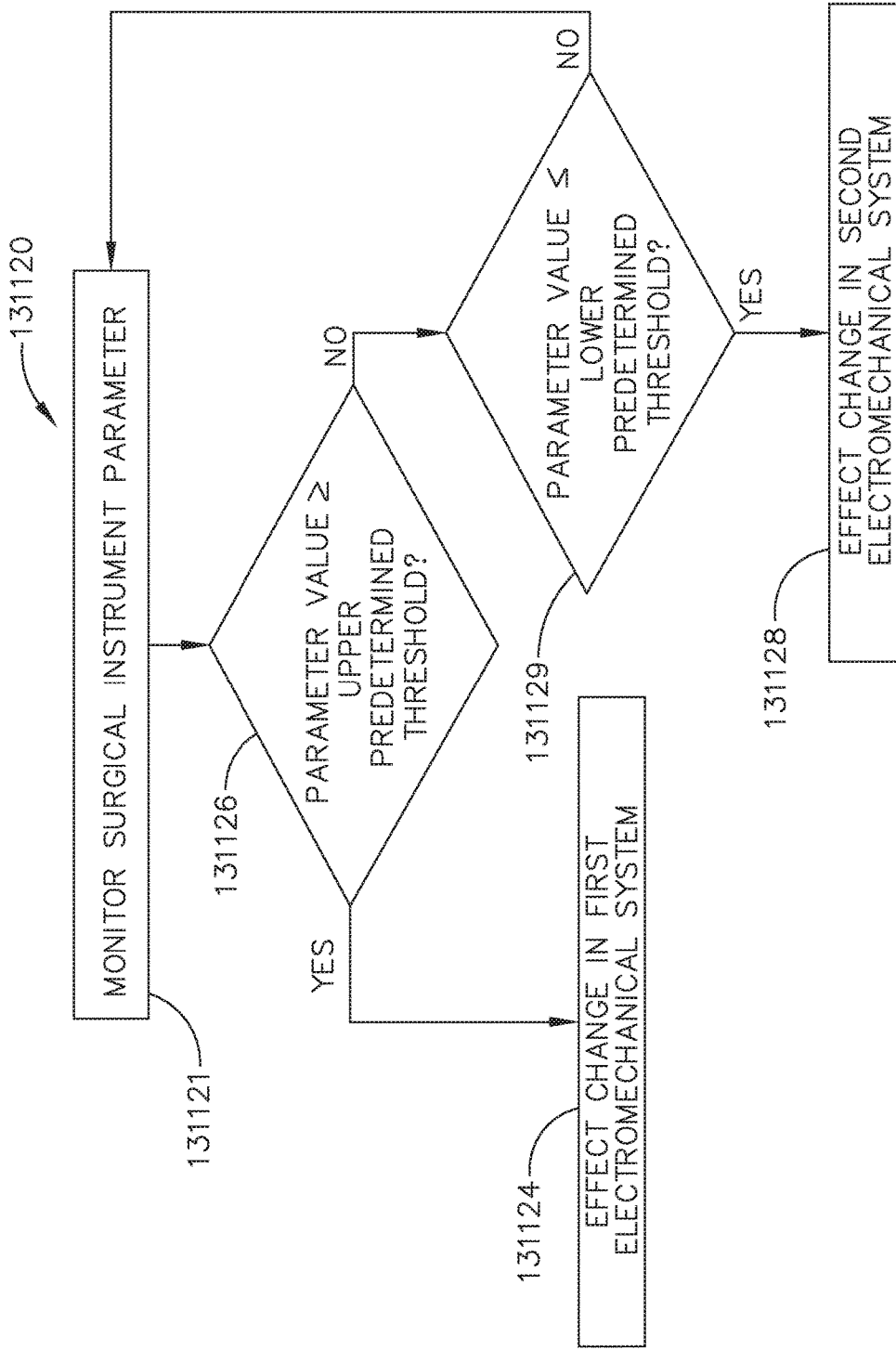

FIG. 83

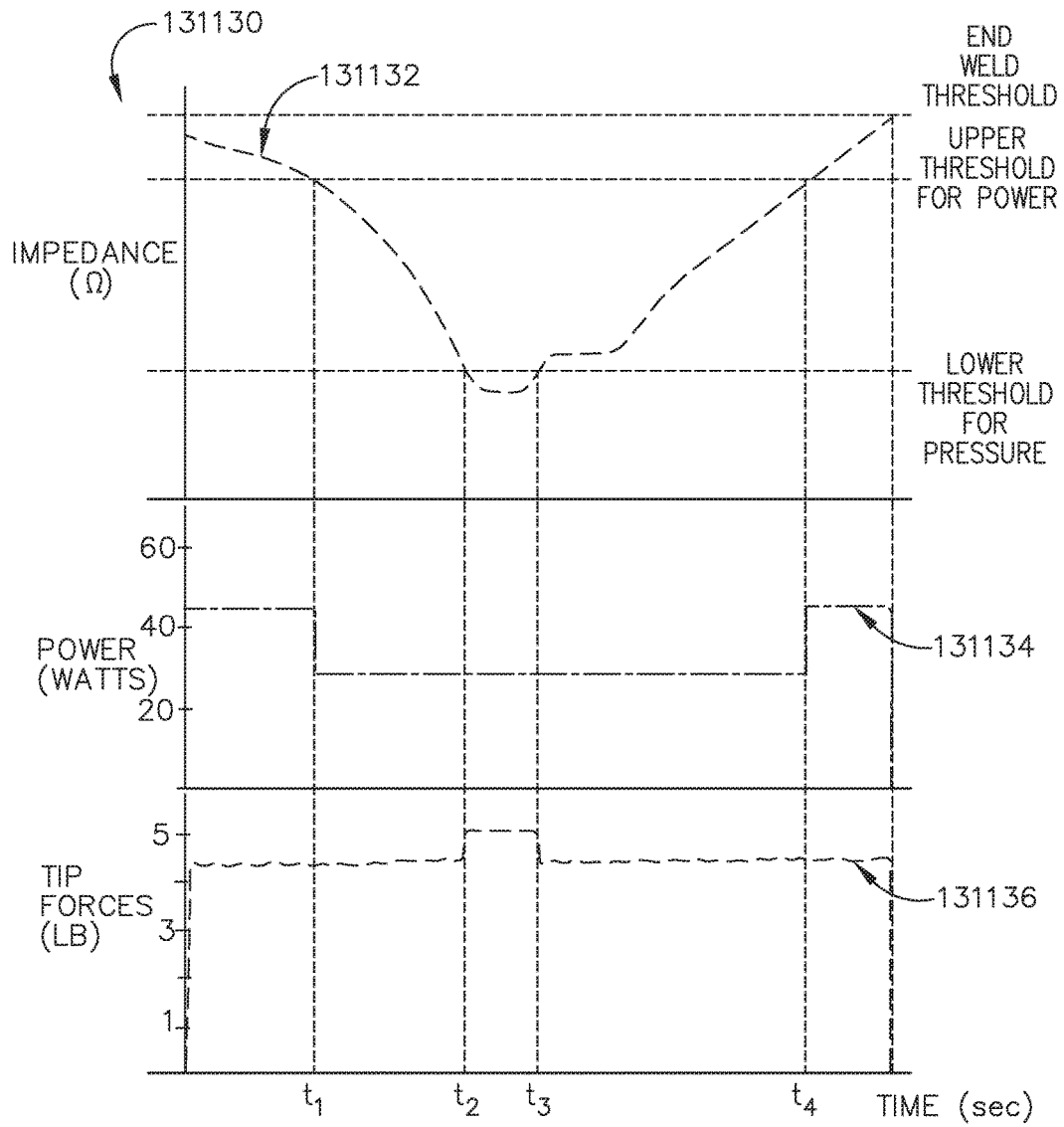

FIG. 84

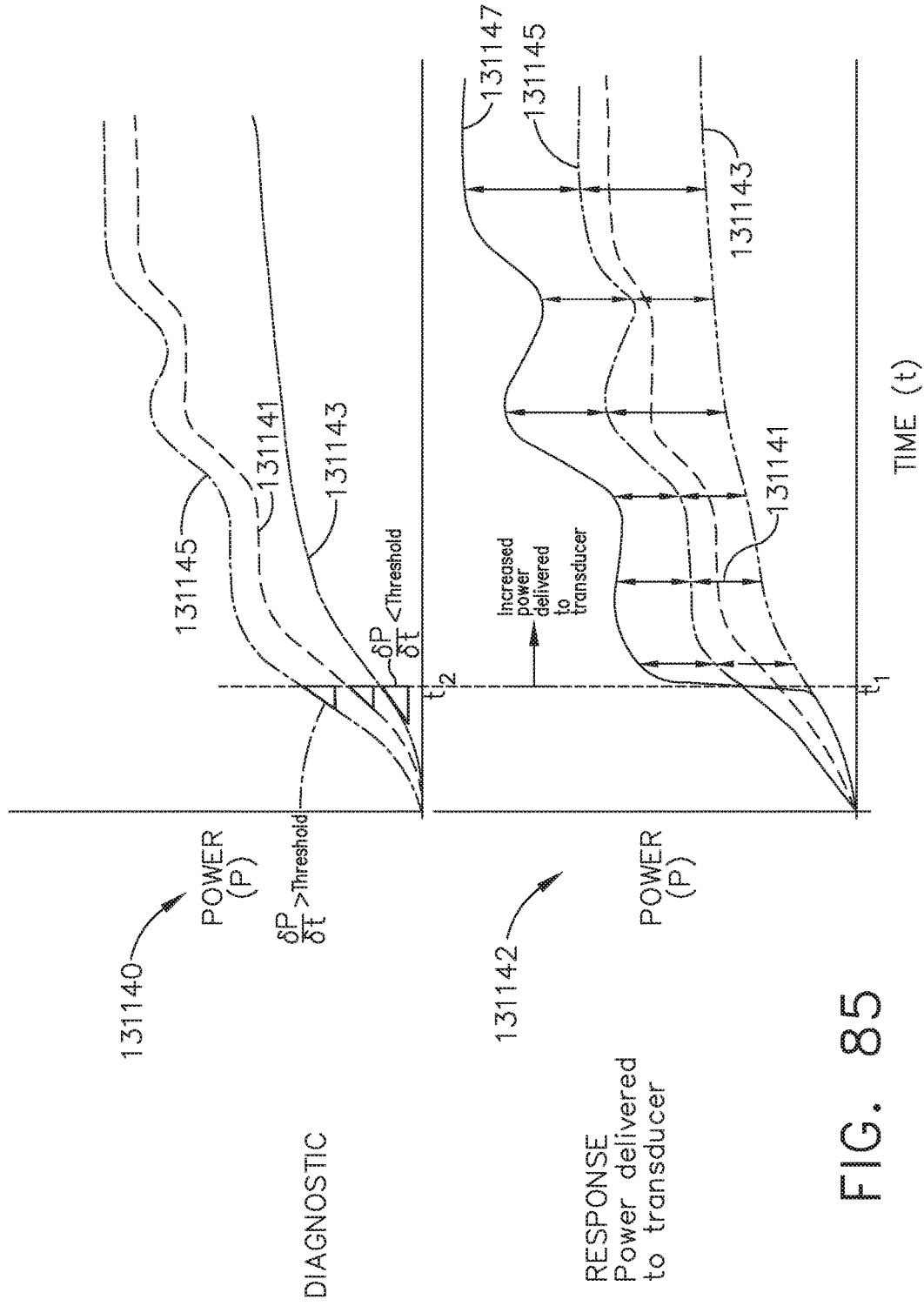

FIG. 85

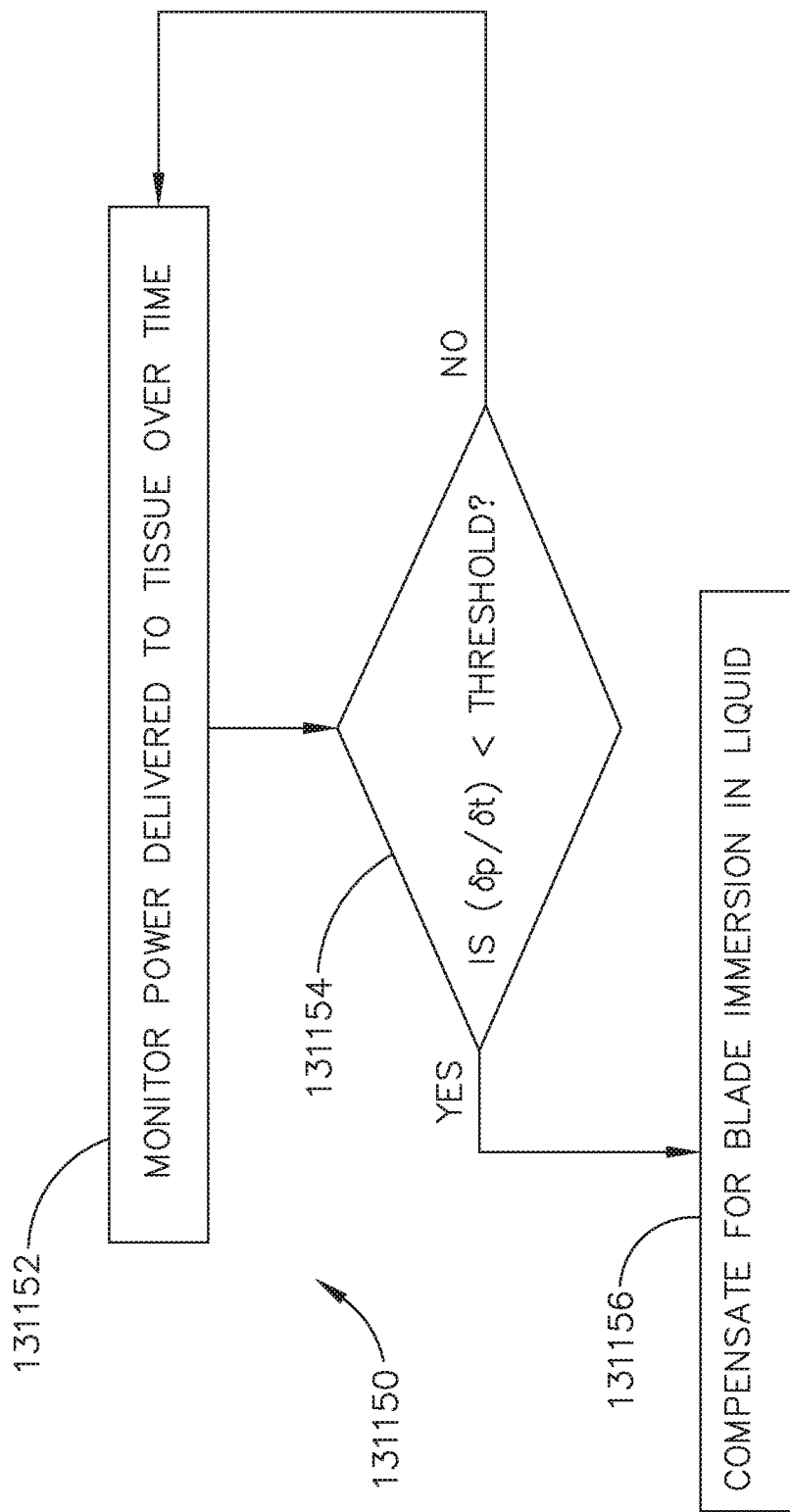

FIG. 86

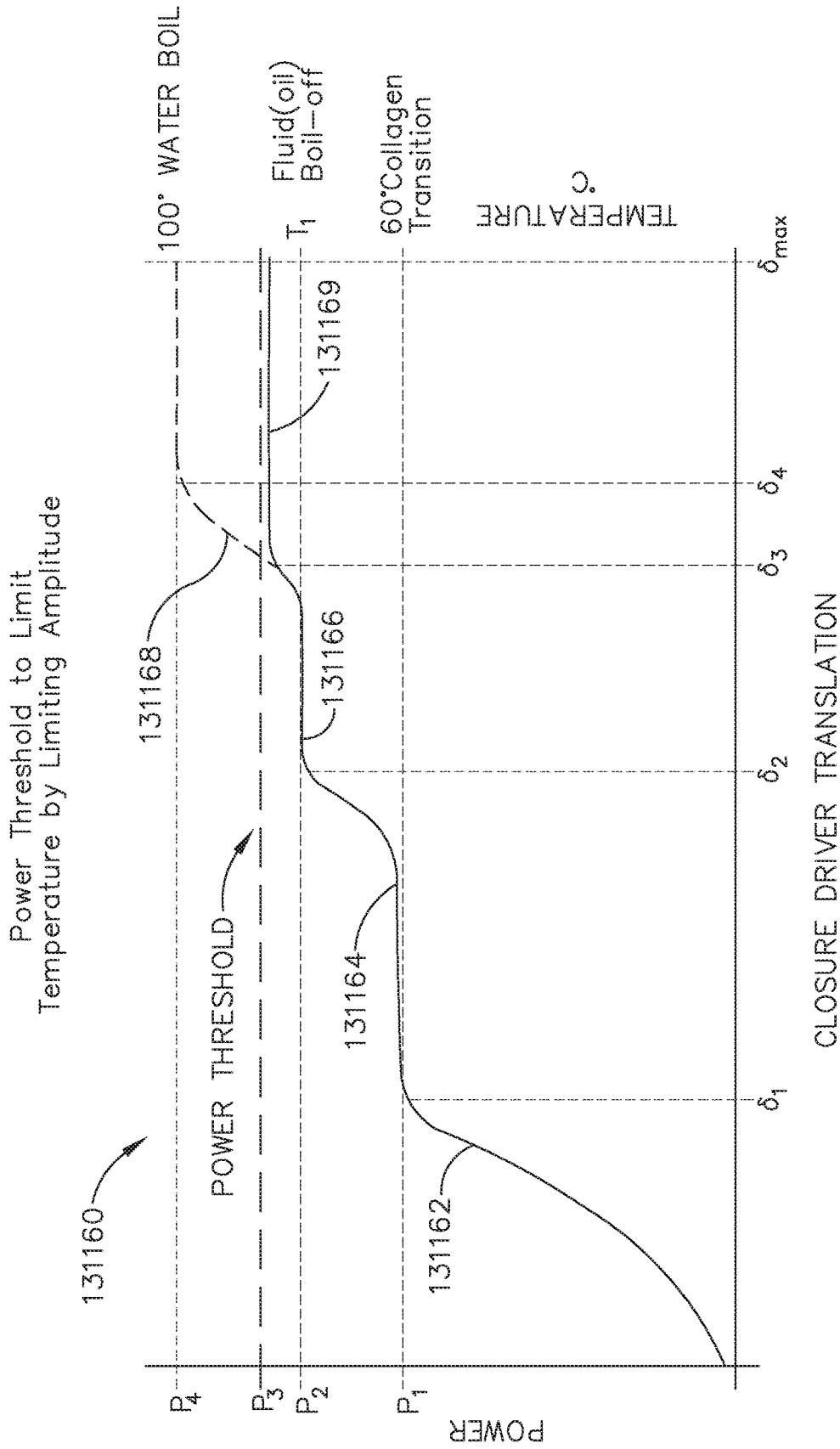

FIG. 87

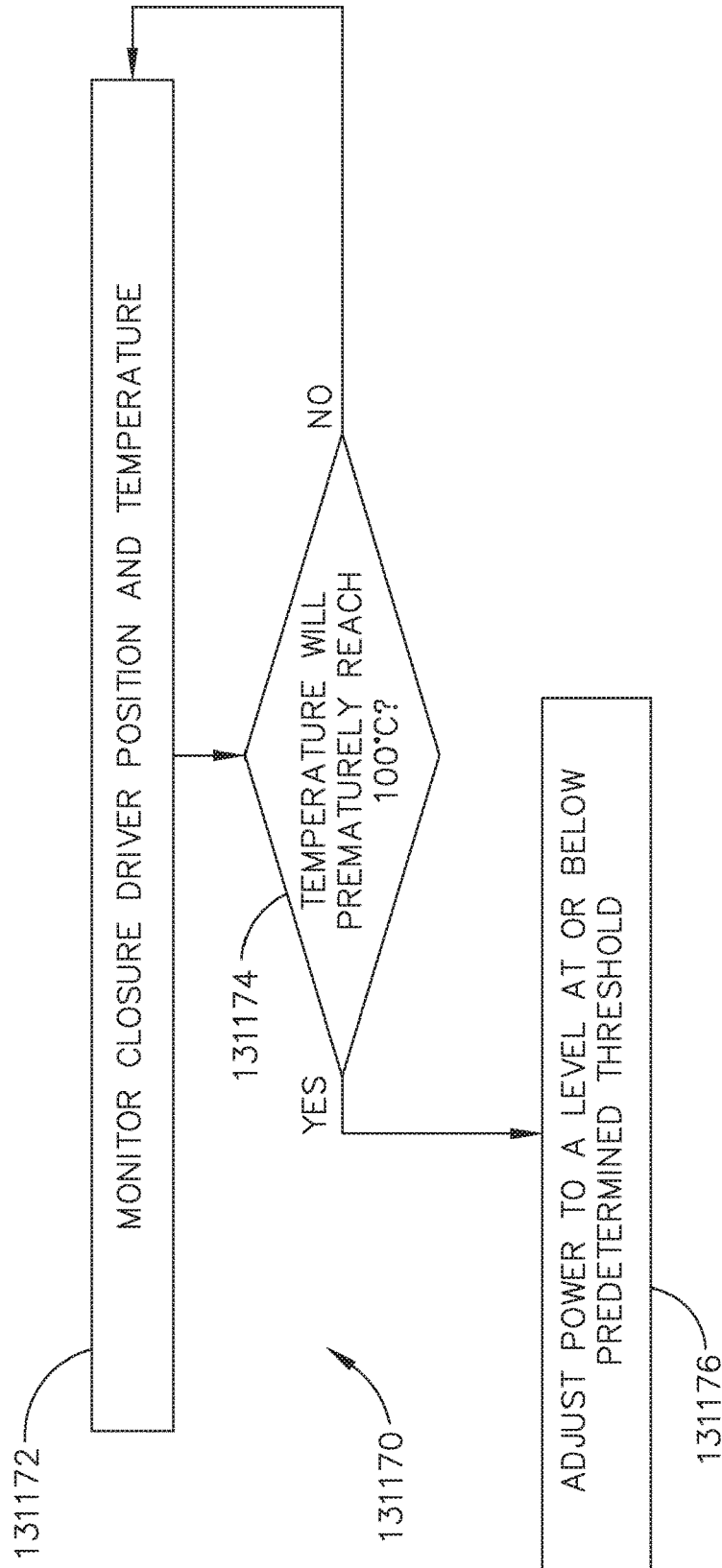

FIG. 88

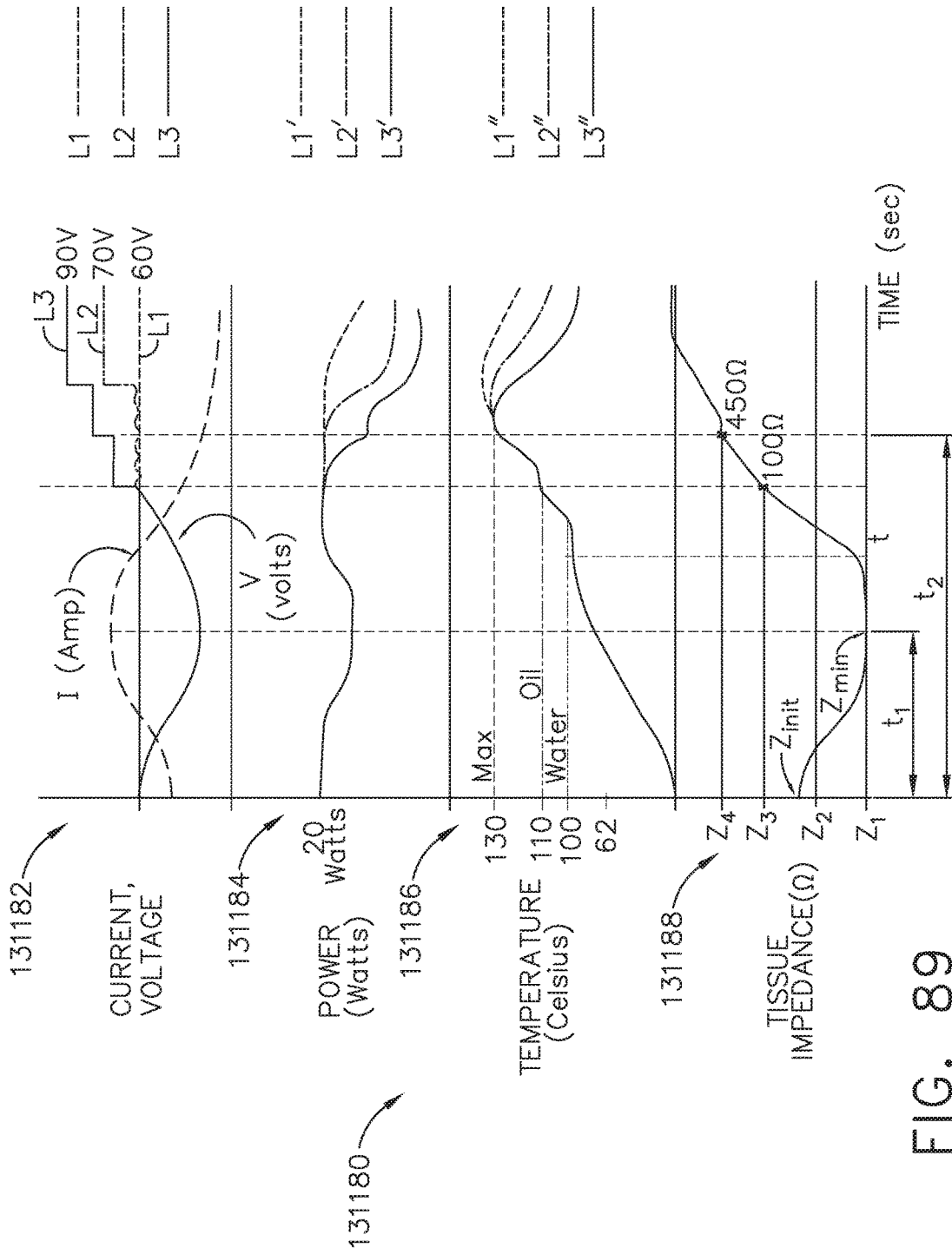

FIG. 89

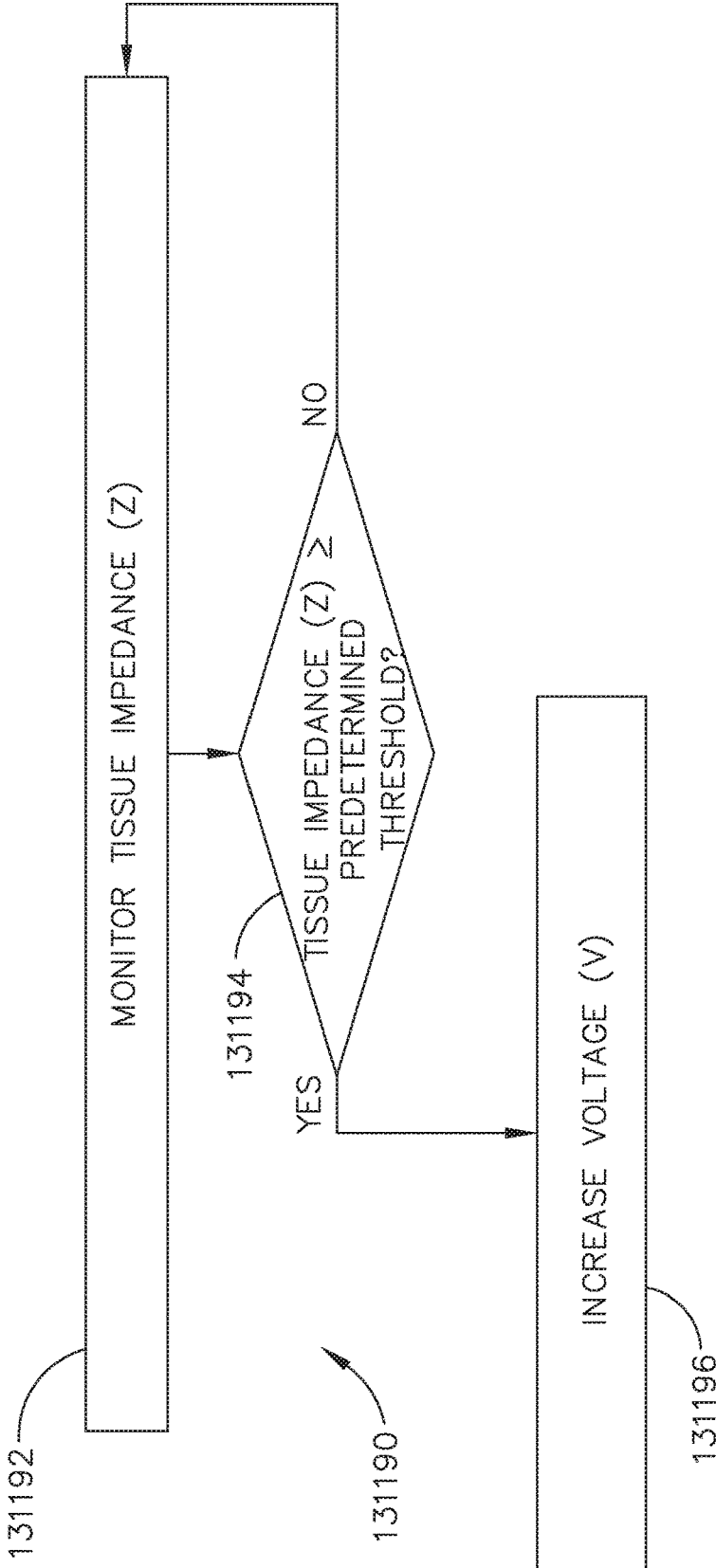

FIG. 90

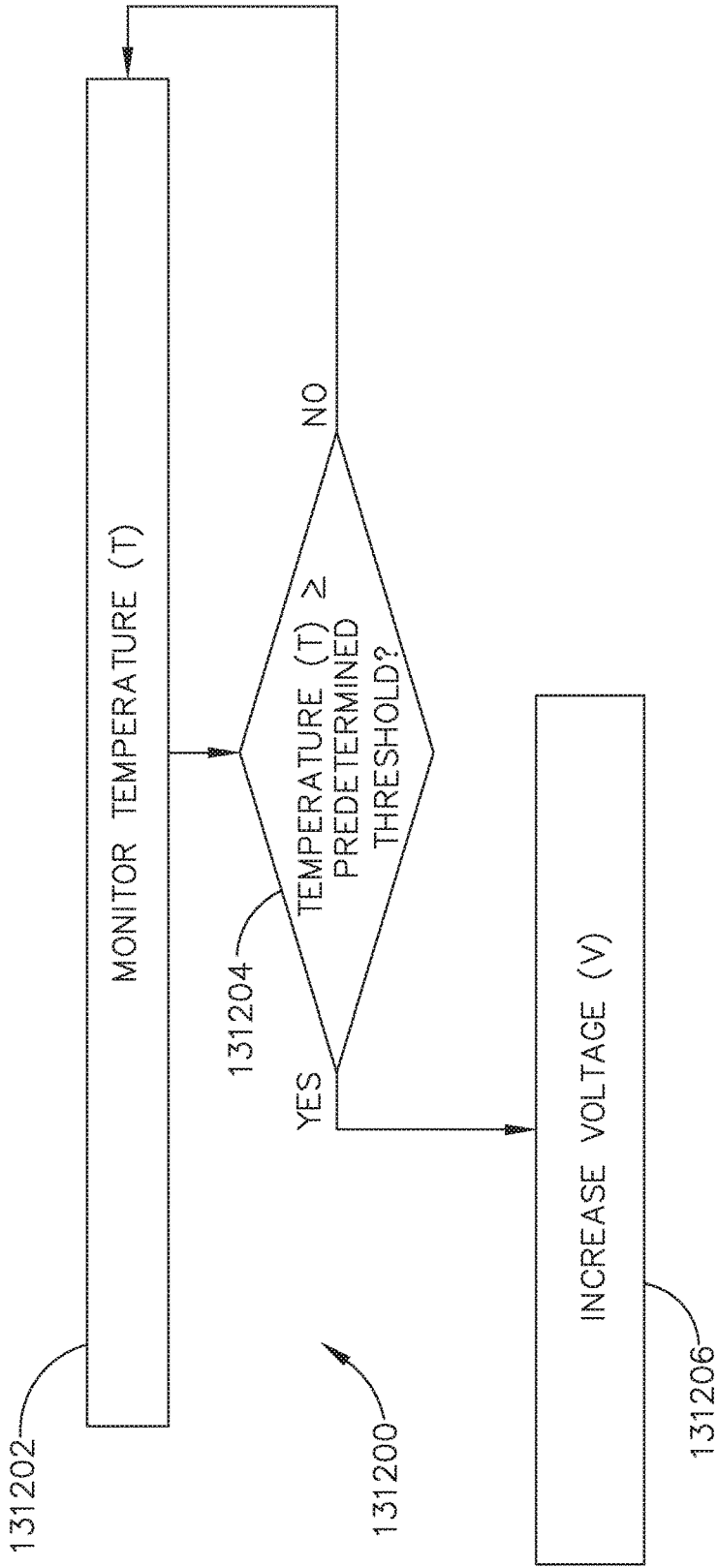

FIG. 91

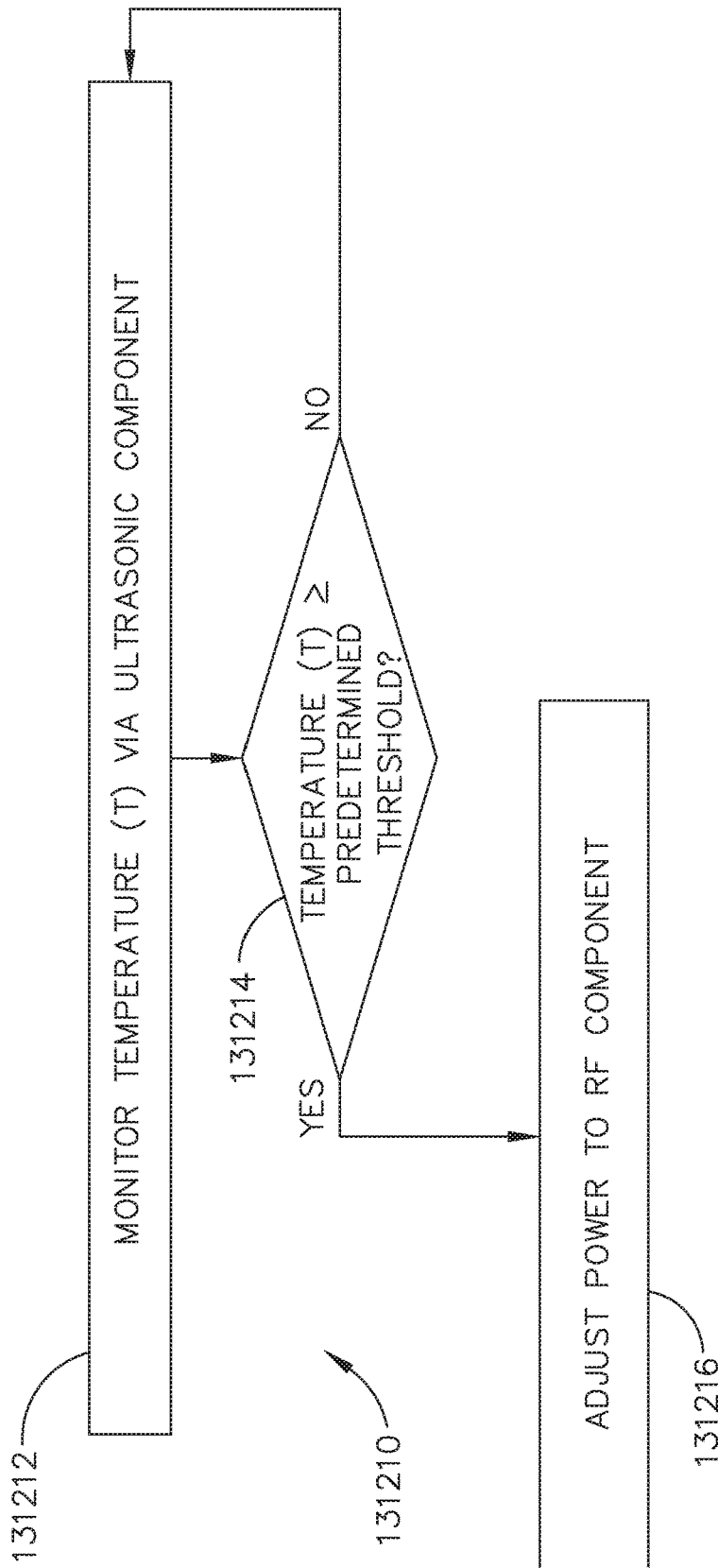

FIG. 92

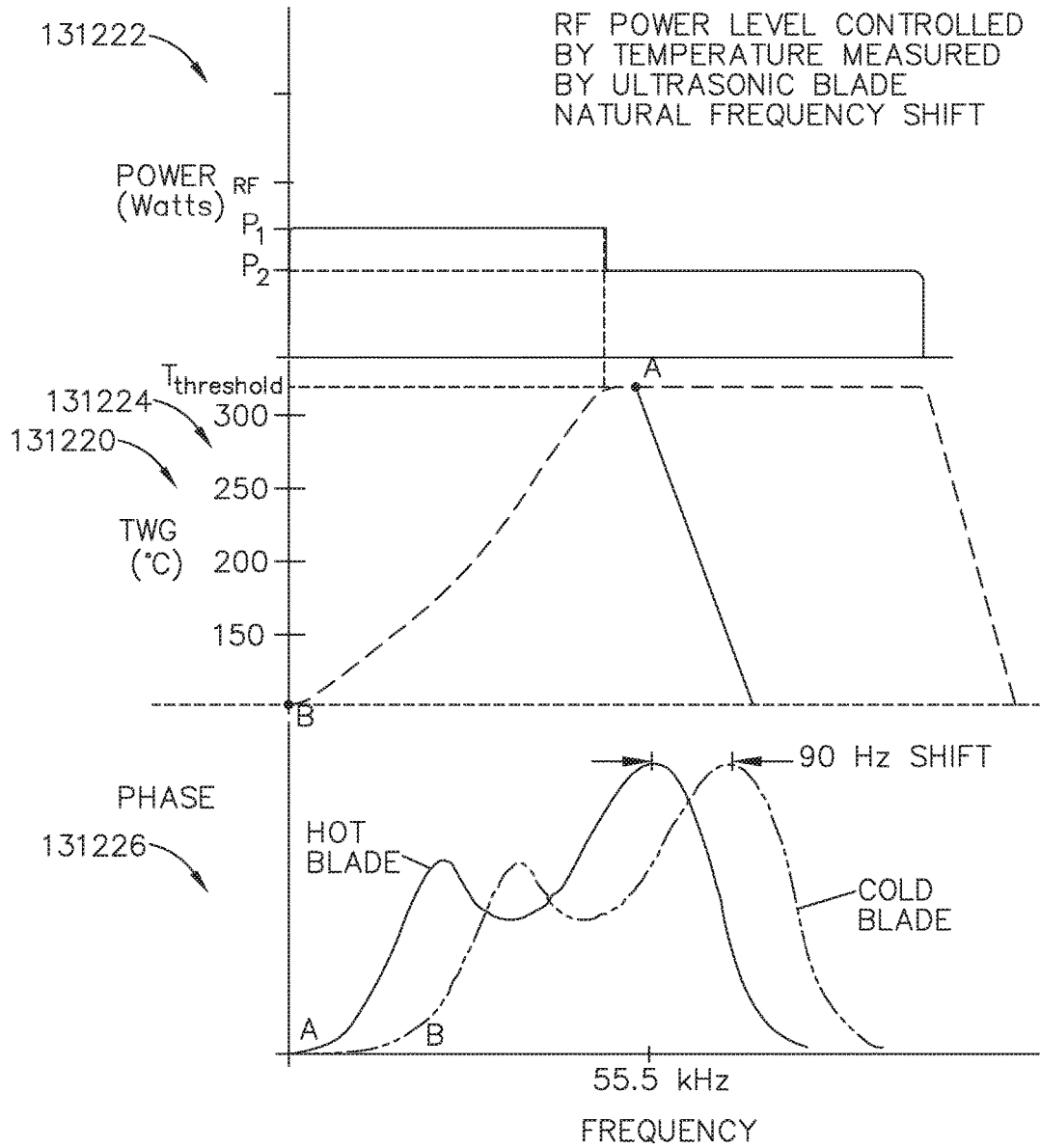

FIG. 93

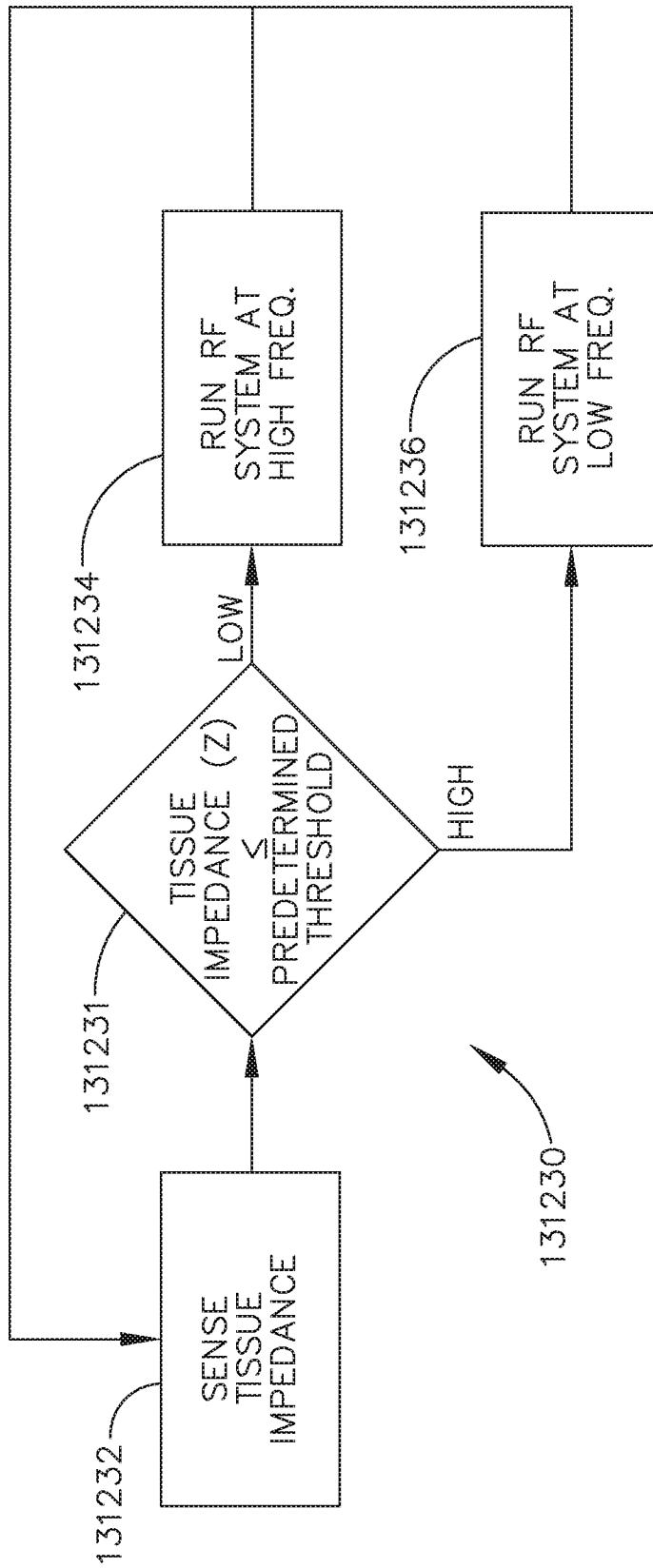

FIG. 94

**SITUATIONAL AWARENESS OF
ELECTROSURGICAL SYSTEMS****CROSS-REFERENCE TO RELATED
APPLICATIONS**

[0001] The present application claims priority under 35 U.S.C. § 119(e) to U.S. Provisional Patent Application No. 62/721,995, titled CONTROLLING AN ULTRASONIC SURGICAL INSTRUMENT ACCORDING TO TISSUE LOCATION, filed on Aug. 23, 2018, the disclosure of which is herein incorporated by reference in its entirety.

[0002] The present application claims priority under 35 U.S.C. § 119(e) to U.S. Provisional Patent Application No. 62/721,998, titled SITUATIONAL AWARENESS OF ELECTROSURGICAL SYSTEMS, filed on Aug. 23, 2018, the disclosure of which is herein incorporated by reference in its entirety.

[0003] The present application claims priority under 35 U.S.C. § 119(e) to U.S. Provisional Patent Application No. 62/721,999, titled INTERRUPTION OF ENERGY DUE TO INADVERTENT CAPACITIVE COUPLING, filed on Aug. 23, 2018, the disclosure of which is herein incorporated by reference in its entirety.

[0004] The present application claims priority under 35 U.S.C. § 119(e) to U.S. Provisional Patent Application No. 62/721,994, titled BIPOLAR COMBINATION DEVICE THAT AUTOMATICALLY ADJUSTS PRESSURE BASED ON ENERGY MODALITY, filed on Aug. 23, 2018, the disclosure of which is herein incorporated by reference in its entirety.

[0005] The present application claims priority under 35 U.S.C. § 119(e) to U.S. Provisional Patent Application No. 62/721,996, titled RADIO FREQUENCY ENERGY DEVICE FOR DELIVERING COMBINED ELECTRICAL SIGNALS, filed on Aug. 23, 2018, the disclosure of which is herein incorporated by reference in its entirety.

[0006] The present application also claims priority under 35 U.S.C. § 119(e) to U.S. Provisional Patent Application No. 62/692,747, titled SMART ACTIVATION OF AN ENERGY DEVICE BY ANOTHER DEVICE, filed on Jun. 30, 2018, to U.S. Provisional Patent Application No. 62/692,748, titled SMART ENERGY ARCHITECTURE, filed on Jun. 30, 2018, and to U.S. Provisional Patent Application No. 62/692,768, titled SMART ENERGY DEVICES, filed on Jun. 30, 2018, the disclosure of each of which is herein incorporated by reference in its entirety.

[0007] This application also claims the benefit of priority under 35 U.S.C. § 119(e) to U.S. Provisional Patent Application No. 62/650,898 filed on Mar. 30, 2018, titled CAPACITIVE COUPLED RETURN PATH PAD WITH SEPARABLE ARRAY ELEMENTS, to U.S. Provisional Patent Application Ser. No. 62/650,887, titled SURGICAL SYSTEMS WITH OPTIMIZED SENSING CAPABILITIES, filed Mar. 30, 2018, to U.S. Provisional Patent Application Ser. No. 62/650,882, titled SMOKE EVACUATION MODULE FOR INTERACTIVE SURGICAL PLATFORM, filed Mar. 30, 2018, and to U.S. Provisional Patent Application Ser. No. 62/650,877, titled SURGICAL SMOKE EVACUATION SENSING AND CONTROLS, filed Mar. 30, 2018, the disclosure of each of which is herein incorporated by reference in its entirety.

[0008] This application also claims the benefit of priority under 35 U.S.C. § 119(e) to U.S. Provisional Patent Application Ser. No. 62/611,341, titled INTERACTIVE SURGI-

CAL PLATFORM, filed Dec. 28, 2017, to U.S. Provisional Patent Application Ser. No. 62/611,340, titled CLOUD-BASED MEDICAL ANALYTICS, filed Dec. 28, 2017, and to U.S. Provisional Patent Application Ser. No. 62/611,339, titled ROBOT ASSISTED SURGICAL PLATFORM, filed Dec. 28, 2017, the disclosure of each of which is herein incorporated by reference in its entirety.

BACKGROUND

[0009] In a surgical environment, smart energy devices may be needed in a smart energy architecture environment.

FIGURES

[0010] The features of various aspects are set forth with particularity in the appended claims. The various aspects, however, both as to organization and methods of operation, together with further objects and advantages thereof, may best be understood by reference to the following description, taken in conjunction with the accompanying drawings as follows.

[0011] FIG. 1 is a block diagram of a computer-implemented interactive surgical system, in accordance with at least one aspect of the present disclosure.

[0012] FIG. 2 is a surgical system being used to perform a surgical procedure in an operating room, in accordance with at least one aspect of the present disclosure.

[0013] FIG. 3 is a surgical hub paired with a visualization system, a robotic system, and an intelligent instrument, in accordance with at least one aspect of the present disclosure.

[0014] FIG. 4 is a partial perspective view of a surgical hub enclosure, and of a combo generator module slidably receivable in a drawer of the surgical hub enclosure, in accordance with at least one aspect of the present disclosure.

[0015] FIG. 5 is a perspective view of a combo generator module with bipolar, ultrasonic, and monopolar contacts and a smoke evacuation component, in accordance with at least one aspect of the present disclosure.

[0016] FIG. 6 illustrates individual power bus attachments for a plurality of lateral docking ports of a lateral modular housing configured to receive a plurality of modules, in accordance with at least one aspect of the present disclosure.

[0017] FIG. 7 illustrates a vertical modular housing configured to receive a plurality of modules, in accordance with at least one aspect of the present disclosure.

[0018] FIG. 8 illustrates a surgical data network comprising a modular communication hub configured to connect modular devices located in one or more operating theaters of a healthcare facility, or any room in a healthcare facility specially equipped for surgical operations, to the cloud, in accordance with at least one aspect of the present disclosure.

[0019] FIG. 9 illustrates a computer-implemented interactive surgical system, in accordance with at least one aspect of the present disclosure.

[0020] FIG. 10 illustrates a surgical hub comprising a plurality of modules coupled to the modular control tower, in accordance with at least one aspect of the present disclosure.

[0021] FIG. 11 illustrates one aspect of a Universal Serial Bus (USB) network hub device, in accordance with at least one aspect of the present disclosure.

[0022] FIG. 12 illustrates a logic diagram of a control system of a surgical instrument or tool, in accordance with at least one aspect of the present disclosure.

[0023] FIG. 13 illustrates a control circuit configured to control aspects of the surgical instrument or tool, in accordance with at least one aspect of the present disclosure.

[0024] FIG. 14 illustrates a combinational logic circuit configured to control aspects of the surgical instrument or tool, in accordance with at least one aspect of the present disclosure.

[0025] FIG. 15 illustrates a sequential logic circuit configured to control aspects of the surgical instrument or tool, in accordance with at least one aspect of the present disclosure.

[0026] FIG. 16 illustrates a surgical instrument or tool comprising a plurality of motors which can be activated to perform various functions, in accordance with at least one aspect of the present disclosure.

[0027] FIG. 17 is a schematic diagram of a robotic surgical instrument configured to operate a surgical tool described herein, in accordance with at least one aspect of the present disclosure.

[0028] FIG. 18 illustrates a block diagram of a surgical instrument programmed to control the distal translation of a displacement member, in accordance with at least one aspect of the present disclosure.

[0029] FIG. 19 is a schematic diagram of a surgical instrument configured to control various functions, in accordance with at least one aspect of the present disclosure.

[0030] FIG. 20 is a system configured to execute adaptive ultrasonic blade control algorithms in a surgical data network comprising a modular communication hub, in accordance with at least one aspect of the present disclosure.

[0031] FIG. 21 illustrates an example of a generator, in accordance with at least one aspect of the present disclosure.

[0032] FIG. 22 is a surgical system comprising a generator and various surgical instruments usable therewith, in accordance with at least one aspect of the present disclosure.

[0033] FIG. 23 is an end effector, in accordance with at least one aspect of the present disclosure.

[0034] FIG. 24 is a diagram of the surgical system of FIG. 22, in accordance with at least one aspect of the present disclosure.

[0035] FIG. 25 is a model illustrating motional branch current, in accordance with at least one aspect of the present disclosure.

[0036] FIG. 26 is a structural view of a generator architecture, in accordance with at least one aspect of the present disclosure.

[0037] FIGS. 27A-27C are functional views of a generator architecture, in accordance with at least one aspect of the present disclosure.

[0038] FIGS. 28A-28B are structural and functional aspects of a generator, in accordance with at least one aspect of the present disclosure.

[0039] FIG. 29 is a schematic diagram of one aspect of an ultrasonic drive circuit.

[0040] FIG. 30 is a schematic diagram of the transformer coupled to the ultrasonic drive circuit shown in FIG. 29, in accordance with at least one aspect of the present disclosure.

[0041] FIG. 31 is a schematic diagram of the transformer shown in FIG. 30 coupled to a test circuit, in accordance with at least one aspect of the present disclosure.

[0042] FIG. 32 is a schematic diagram of a control circuit, in accordance with at least one aspect of the present disclosure.

[0043] FIG. 33 shows a simplified block circuit diagram illustrating another electrical circuit contained within a modular ultrasonic surgical instrument, in accordance with at least one aspect of the present disclosure.

[0044] FIG. 34 illustrates a generator circuit partitioned into multiple stages, in accordance with at least one aspect of the present disclosure.

[0045] FIG. 35 illustrates a generator circuit partitioned into multiple stages where a first stage circuit is common to the second stage circuit, in accordance with at least one aspect of the present disclosure.

[0046] FIG. 36 is a schematic diagram of one aspect of a drive circuit configured for driving a high-frequency current (RF), in accordance with at least one aspect of the present disclosure.

[0047] FIG. 37 is a schematic diagram of the transformer coupled to the RF drive circuit shown in FIG. 34, in accordance with at least one aspect of the present disclosure.

[0048] FIG. 38 is a schematic diagram of a circuit comprising separate power sources for high power energy/drive circuits and low power circuits, according to one aspect of the present disclosure.

[0049] FIG. 39 illustrates a control circuit that allows a dual generator system to switch between the RF generator and the ultrasonic generator energy modalities for a surgical instrument.

[0050] FIG. 40 illustrates a diagram of one aspect of a surgical instrument comprising a feedback system for use with a surgical instrument, according to one aspect of the present disclosure.

[0051] FIG. 41 illustrates one aspect of a fundamental architecture for a digital synthesis circuit such as a direct digital synthesis (DDS) circuit configured to generate a plurality of wave shapes for the electrical signal waveform for use in a surgical instrument, in accordance with at least one aspect of the present disclosure.

[0052] FIG. 42 illustrates one aspect of direct digital synthesis (DDS) circuit configured to generate a plurality of wave shapes for the electrical signal waveform for use in surgical instrument, in accordance with at least one aspect of the present disclosure.

[0053] FIG. 43 illustrates one cycle of a discrete time digital electrical signal waveform, in accordance with at least one aspect of the present disclosure of an analog waveform (shown superimposed over a discrete time digital electrical signal waveform for comparison purposes), in accordance with at least one aspect of the present disclosure.

[0054] FIG. 44 is a diagram of a control system configured to provide progressive closure of a closure member as it advances distally to close the clamp arm to apply a closure force load at a desired rate according to one aspect of this disclosure.

[0055] FIG. 45 illustrates a proportional-integral-derivative (PID) controller feedback control system according to one aspect of this disclosure.

[0056] FIG. 46 is an elevational exploded view of modular handheld ultrasonic surgical instrument showing the left shell half removed from a handle assembly exposing a device identifier communicatively coupled to the multi-lead handle terminal assembly in accordance with one aspect of the present disclosure.

[0057] FIG. 47 is a detail view of a trigger portion and switch of the ultrasonic surgical instrument shown in FIG. 46, in accordance with at least one aspect of the present disclosure.

[0058] FIG. 48 is a fragmentary, enlarged perspective view of an end effector from a distal end with a jaw member in an open position, in accordance with at least one aspect of the present disclosure.

[0059] FIG. 49 is a system diagram of a segmented circuit comprising a plurality of independently operated circuit segments, in accordance with at least one aspect of the present disclosure.

[0060] FIG. 50 is a circuit diagram of various components of a surgical instrument with motor control functions, in accordance with at least one aspect of the present disclosure.

[0061] FIG. 51 illustrates one aspect of an end effector comprising RF data sensors located on the jaw member, in accordance with at least one aspect of the present disclosure.

[0062] FIG. 52 illustrates one aspect of the flexible circuit shown in FIG. 51 in which the sensors may be mounted to or formed integrally therewith, in accordance with at least one aspect of the present disclosure.

[0063] FIG. 53 is an alternative system for controlling the frequency of an ultrasonic electromechanical system and detecting the impedance thereof, in accordance with at least one aspect of the present disclosure.

[0064] FIG. 54 is a spectra of the same ultrasonic device with a variety of different states and conditions of the end effector where phase and magnitude of the impedance of an ultrasonic transducer are plotted as a function of frequency, in accordance with at least one aspect of the present disclosure.

[0065] FIG. 55 is a graphical representation of a plot of a set of 3D training data S, where ultrasonic transducer impedance magnitude and phase are plotted as a function of frequency, in accordance with at least one aspect of the present disclosure.

[0066] FIG. 56 is a logic flow diagram depicting a control program or a logic configuration to determine jaw conditions based on the complex impedance characteristic pattern (fingerprint), in accordance with at least one aspect of the present disclosure.

[0067] FIG. 57 is a circle plot of complex impedance plotted as an imaginary component versus real components of a piezoelectric vibrator, in accordance with at least one aspect of the present disclosure.

[0068] FIG. 58 is a circle plot of complex admittance plotted as an imaginary component versus real components of a piezoelectric vibrator, in accordance with at least one aspect of the present disclosure.

[0069] FIG. 59 is a circle plot of complex admittance for a 55.5 kHz ultrasonic piezoelectric transducer.

[0070] FIG. 60 is a graphical display of an impedance analyzer showing impedance/admittance circle plots for an ultrasonic device with the jaw open and no loading where red depicts admittance and blue depicts impedance, in accordance with at least one aspect of the present disclosure.

[0071] FIG. 61 is a graphical display of an impedance analyzer showing impedance/admittance circle plots for an ultrasonic device with the jaw clamped on dry chamois where red depicts admittance and blue depicts impedance, in accordance with at least one aspect of the present disclosure.

[0072] FIG. 62 is a graphical display of an impedance analyzer showing impedance/admittance circle plots for an

ultrasonic device with the jaw tip clamped on moist chamois where red depicts admittance and blue depicts impedance, in accordance with at least one aspect of the present disclosure.

[0073] FIG. 63 is a graphical display of an impedance analyzer showing impedance/admittance circle plots for an ultrasonic device with the jaw fully clamped on moist chamois where red depicts admittance and blue depicts impedance, in accordance with at least one aspect of the present disclosure.

[0074] FIG. 64 is a graphical display of an impedance analyzer showing impedance/admittance plots where frequency is swept from 48 kHz to 62 kHz to capture multiple resonances of an ultrasonic device with the jaw open where the gray overlay is to help see the circles, in accordance with at least one aspect of the present disclosure.

[0075] FIG. 65 is a logic flow diagram of a process depicting a control program or a logic configuration to determine jaw conditions based on estimates of the radius and offsets of an impedance/admittance circle, in accordance with at least one aspect of the present disclosure.

[0076] FIGS. 66A-66B are complex impedance spectra of the same ultrasonic device with a cold (blue) and hot (red) ultrasonic blade, in accordance with at least one aspect of the present disclosure, where

[0077] FIG. 66A is a graphical representation of impedance phase angle as a function of resonant frequency of the same ultrasonic device with a cold (blue) and hot (red) ultrasonic blade; and

[0078] FIG. 66B is a graphical representation of impedance magnitude as a function of resonant frequency of the same ultrasonic device with a cold (blue) and hot (red) ultrasonic blade.

[0079] FIG. 67 is a diagram of a Kalman filter to improve temperature estimator and state space model based on impedance across an ultrasonic transducer measured at a variety of frequencies, in accordance with at least one aspect of the present disclosure.

[0080] FIG. 68 are three probability distributions employed by a state estimator of the Kalman filter shown in FIG. 67 to maximize estimates, in accordance with at least one aspect of the present disclosure.

[0081] FIG. 69A is a graphical representation of temperature versus time of an ultrasonic device with no temperature control reaching a maximum temperature of 490° C.

[0082] FIG. 69B is a graphical representation of temperature versus time of an ultrasonic device with temperature control reaching a maximum temperature of 320° C., in accordance with at least one aspect of the present disclosure.

[0083] FIGS. 70A-70B are graphical representations of feedback control to adjust ultrasonic power applied to an ultrasonic transducer when a sudden drop in temperature of an ultrasonic blade is detected, where

[0084] FIG. 70A is a graphical representation of ultrasonic power as a function of time; and

[0085] FIG. 70B is a plot of ultrasonic blade temperature as a function of time, in accordance with at least one aspect of the present disclosure.

[0086] FIG. 71 is a logic flow diagram of a process depicting a control program or a logic configuration to control the temperature of an ultrasonic blade, in accordance with at least one aspect of the present disclosure.

[0087] FIG. 72 is a timeline depicting situational awareness of a surgical hub, in accordance with at least one aspect of the present disclosure.

[0088] FIG. 73 illustrates an end effector of an electrosurgical instrument, in accordance with at least one aspect of the present disclosure.

[0089] FIG. 74 is a graph of amplitude vs time depicting therapeutic cycles generated by a transducer of an electrosurgical instrument, in accordance with at least one aspect of the present disclosure.

[0090] FIG. 75A illustrates various closure stages of the end effector of FIG. 73.

[0091] FIG. 75B illustrates various closure stages of the end effector of FIG. 73.

[0092] FIG. 76 is a logic flow diagram of a process depicting a control program or a logic configuration for selecting an energy operational mode of an electrosurgical instrument, in accordance with at least one aspect of the present disclosure.

[0093] FIG. 77 is a logic flow diagram of a process depicting a control program or a logic configuration for selecting an energy operational mode of an electrosurgical instrument, in accordance with at least one aspect of the present disclosure.

[0094] FIG. 78 is a logic flow diagram of a process depicting a control program or a logic configuration for selecting an energy operational mode of an electrosurgical instrument, in accordance with at least one aspect of the present disclosure.

[0095] FIG. 78A is a schematic illustration of a tissue contact circuit showing the completion of the circuit upon contact with tissue a pair of spaced apart contact plates.

[0096] FIG. 79 is a logic flow diagram of a process depicting a control program or a logic configuration for selecting an energy operational mode of an electrosurgical instrument, in accordance with at least one aspect of the present disclosure.

[0097] FIG. 80 is a schematic diagram illustrating a control circuit including an absolute positioning system, in accordance with at least one aspect of the present disclosure.

[0098] FIG. 81 is a logic flow diagram of a process depicting a control program or a logic configuration for switching between energy operational modes of an electrosurgical instrument, in accordance with at least one aspect of the present disclosure.

[0099] FIG. 82 is a logic flow diagram of a process depicting a control program or a logic configuration for adjusting energy delivered to tissue clamped by an end effector of an electrosurgical instrument and energy delivered to a motor of the electrosurgical instrument based on predetermined thresholds of a monitored parameter, in accordance with at least one aspect of the present disclosure.

[0100] FIG. 83 is a logic flow diagram of a process depicting a control program or a logic configuration for adjusting different electromechanical systems of an ultrasonic surgical instrument based on predetermined thresholds of a monitored parameter, in accordance with at least one aspect of the present disclosure.

[0101] FIG. 84 is a graph representing tissue impedance (Z), Power (P), and force (F) at a distal portion (tip) of an end effector of an electrosurgical instrument clamping the tissue, the tissue impedance (Z), Power (P), and force (F) being plotted on the Y-axis against time (t) on the X-axis, in accordance with at least one aspect of the present disclosure.

[0102] FIG. 85 is a graph representing power (P) as a function of time (t) in a diagnostic mode (top graph) and in a response mode (bottom graph).

[0103] FIG. 86 is a logic flow diagram of a process depicting a control program or a logic configuration to detect and compensate for immersion of an ultrasonic blade into a liquid, in accordance with at least one aspect of the present disclosure.

[0104] FIG. 87 depicts a graphical representation of power (p) delivered to an end effector and tissue temperature as functions of a closure driver displacement, in accordance with at least one aspect of the present disclosure.

[0105] FIG. 88 is a logic flow diagram of a process depicting a control program or a logic configuration to detect and compensate for immersion of an ultrasonic blade into a liquid, in accordance with at least one aspect of the present disclosure.

[0106] FIG. 89 is a graph including four graphs, where the first graph from the top represents voltage (V) and current (I) versus time (t), the second graph represents power (P) versus time (t), the third graph represents temperature (T) versus time (t), and the fourth graph represents tissue impedance (Z) versus time (t), in accordance with at least one aspect of the present disclosure.

[0107] FIG. 90 is a logic flow diagram of a process depicting a control program or a logic configuration that utilizes values of tissue impedance (Z) as trigger conditions for stepping up voltage (V) toward the end of a tissue treatment cycle applied by an end effector of an electrosurgical instrument to tissue, in accordance with at least one aspect of the present disclosure.

[0108] FIG. 91 is a logic flow diagram of a process depicting a control program or a logic configuration that utilizes values of temperature (T) as trigger conditions for stepping up voltage (V) toward the end of a tissue treatment cycle applied by an end effector of an electrosurgical instrument to tissue, in accordance with at least one aspect of the present disclosure.

[0109] FIG. 92 is a logic flow diagram of a process depicting a control program or a logic configuration for adjusting power (P) to an RF component of a combo device based on temperature (T) monitored by an ultrasonic component of the combo device, in accordance with at least one aspect of the present disclosure.

[0110] FIG. 93 is a graph including three graphs, where the first graph from the top represents power (P) delivered to tissue captured between jaws of a bipolar RF component of a combo device, where the second graph represents tissue temperature as measured by an ultrasonic component of the combo device, and where the third graph represents dual non-therapeutic frequencies employed by the ultrasonic component to determine tissue temperature, in accordance with at least one aspect of the present disclosure.

[0111] FIG. 94 is a logic flow diagram of a process depicting a control program or a logic configuration for actively adjusting frequency of RF waveform of an RF electrosurgical instrument or an RF component of a combo device based on measured tissue impedance, in accordance with at least one aspect of the present disclosure.

SUMMARY

[0112] In various embodiments, a surgical instrument is disclosed that comprises an end effector comprising an ultrasonic blade and a clamp arm. The clamp arm is movable relative to the ultrasonic blade to transition the end effector through different closure stages between an open configuration and a closed configuration to clamp tissue between the

ultrasonic blade and the clamp arm. The surgical instrument further comprises a transducer configured to generate an ultrasonic energy output, a waveguide configured to transmit the ultrasonic energy output to the ultrasonic blade, and a sensor configured to transmit sensor signals indicative of the closure stages of the end effector. The surgical instrument further comprises a control circuit configured to receive the sensor signals and select an operational mode from operational modes delivering different ultrasonic energy outputs from the transducer based on the received sensor signals.

[0113] In various embodiments, a surgical instrument is disclosed that comprises an end effector comprising an ultrasonic blade and a clamp arm. The clamp arm is movable relative to the ultrasonic blade to transition the end effector through different closure stages between an open configuration and a closed configuration to clamp tissue between the ultrasonic blade and the clamp arm. The closure stages comprise a first closure stage and a second closure stage after the first closure stage. The surgical instrument further comprises a transducer configured to generate an ultrasonic energy output, a waveguide configured to transmit the ultrasonic energy output to the ultrasonic blade, and a sensor circuit configured to transmit a sensor signal indicative of detecting an initial contact of the clamp arm with the tissue. The surgical instrument further comprises a control circuit configured to receive the sensor signal, cause the transducer to generate a first ultrasonic energy output in response to receiving the sensor signal in the first closure stage, and cause the transducer to generate a second ultrasonic energy output greater than the first ultrasonic output in response to receiving the sensor signal in the second closure stage.

DESCRIPTION

[0114] Applicant of the present application owns the following U.S. patent applications, filed on Aug. 28, 2018, the disclosure of each of which is herein incorporated by reference in its entirety:

[0115] U.S. patent application Docket No. END8536USNP2/180107-2, titled ESTIMATING STATE OF ULTRASONIC END EFFECTOR AND CONTROL SYSTEM THEREFOR;

[0116] U.S. patent application Docket No. END8560USNP2/180106-2, titled TEMPERATURE CONTROL OF ULTRASONIC END EFFECTOR AND CONTROL SYSTEM THEREFOR;

[0117] U.S. patent application Docket No. END8561USNP1/180144-1, titled RADIO FREQUENCY ENERGY DEVICE FOR DELIVERING COMBINED ELECTRICAL SIGNALS;

[0118] U.S. patent application Docket No. END8563USNP1/180139-1, titled CONTROLLING AN ULTRASONIC SURGICAL INSTRUMENT ACCORDING TO TISSUE LOCATION;

[0119] U.S. patent application Docket No. END8563USNP2/180139-2, titled CONTROLLING ACTIVATION OF AN ULTRASONIC SURGICAL INSTRUMENT ACCORDING TO THE PRESENCE OF TISSUE;

[0120] U.S. patent application Docket No. END8563USNP3/180139-3, titled DETERMINING TISSUE COMPOSITION VIA AN ULTRASONIC SYSTEM;

[0121] U.S. patent application Docket No. END8563USNP4/180139-4, titled DETERMINING

THE STATE OF AN ULTRASONIC ELECTROMECHANICAL SYSTEM ACCORDING TO FREQUENCY SHIFT;

[0122] U.S. patent application Docket No. END8563USNP5/180139-5, titled DETERMINING THE STATE OF AN ULTRASONIC END EFFECTOR;

[0123] U.S. patent application Docket No. END8564USNP2/180140-2, titled MECHANISMS FOR CONTROLLING DIFFERENT ELECTROMECHANICAL SYSTEMS OF AN ELECTROSURGICAL INSTRUMENT;

[0124] U.S. patent application Docket No. END8564USNP3/180140-3, titled DETECTION OF END EFFECTOR IMMERSION IN LIQUID;

[0125] U.S. patent application Docket No. END8565USNP1/180142-1, titled INTERRUPTION OF ENERGY DUE TO INADVERTENT CAPACITIVE COUPLING;

[0126] U.S. patent application Docket No. END8565USNP2/180142-2, titled INCREASING RADIO FREQUENCY TO CREATE PAD-LESS MONOPOLAR LOOP;

[0127] U.S. patent application Docket No. END8566USNP1/180143-1, titled BIPOLAR COMBINATION DEVICE THAT AUTOMATICALLY ADJUSTS PRESSURE BASED ON ENERGY MODALITY; and

[0128] U.S. patent application Docket No. END8573USNP1/180145-1, titled ACTIVATION OF ENERGY DEVICES.

[0129] Applicant of the present application owns the following U.S. patent applications, filed on Aug. 23, 2018, the disclosure of each of which is herein incorporated by reference in its entirety:

[0130] U.S. Provisional Patent Application No. 62/721, 995, titled CONTROLLING AN ULTRASONIC SURGICAL INSTRUMENT ACCORDING TO TISSUE LOCATION;

[0131] U.S. Provisional Patent Application No. 62/721, 998, titled SITUATIONAL AWARENESS OF ELECTROSURGICAL SYSTEMS;

[0132] U.S. Provisional Patent Application No. 62/721, 999, titled INTERRUPTION OF ENERGY DUE TO INADVERTENT CAPACITIVE COUPLING;

[0133] U.S. Provisional Patent Application No. 62/721, 994, titled BIPOLAR COMBINATION DEVICE THAT AUTOMATICALLY ADJUSTS PRESSURE BASED ON ENERGY MODALITY; and

[0134] U.S. Provisional Patent Application No. 62/721, 996, titled RADIO FREQUENCY ENERGY DEVICE FOR DELIVERING COMBINED ELECTRICAL SIGNALS.

[0135] Applicant of the present application owns the following U.S. patent applications, filed on Jun. 30, 2018, the disclosure of each of which is herein incorporated by reference in its entirety:

[0136] U.S. Provisional Patent Application No. 62/692, 747, titled SMART ACTIVATION OF AN ENERGY DEVICE BY ANOTHER DEVICE;

[0137] U.S. Provisional Patent Application No. 62/692, 748, titled SMART ENERGY ARCHITECTURE; and

[0138] U.S. Provisional Patent Application No. 62/692, 768, titled SMART ENERGY DEVICES.

[0139] Applicant of the present application owns the following U.S. patent applications, filed on Jun. 29, 2018, the disclosure of each of which is herein incorporated by reference in its entirety:

- [0140] U.S. patent application Ser. No. 16/024,090, titled CAPACITIVE COUPLED RETURN PATH PAD WITH SEPARABLE ARRAY ELEMENTS;
- [0141] U.S. patent application Ser. No. 16/024,057, titled CONTROLLING A SURGICAL INSTRUMENT ACCORDING TO SENSED CLOSURE PARAMETERS;
- [0142] U.S. patent application Ser. No. 16/024,067, titled SYSTEMS FOR ADJUSTING END EFFECTOR PARAMETERS BASED ON PERIOPERATIVE INFORMATION;
- [0143] U.S. patent application Ser. No. 16/024,075, titled SAFETY SYSTEMS FOR SMART POWERED SURGICAL STAPLING;
- [0144] U.S. patent application Ser. No. 16/024,083, titled SAFETY SYSTEMS FOR SMART POWERED SURGICAL STAPLING;
- [0145] U.S. patent application Ser. No. 16/024,094, titled SURGICAL SYSTEMS FOR DETECTING END EFFECTOR TISSUE DISTRIBUTION IRREGULARITIES;
- [0146] U.S. patent application Ser. No. 16/024,138, titled SYSTEMS FOR DETECTING PROXIMITY OF SURGICAL END EFFECTOR TO CANCEROUS TISSUE;
- [0147] U.S. patent application Ser. No. 16/024,150, titled SURGICAL INSTRUMENT CARTRIDGE SENSOR ASSEMBLIES;
- [0148] U.S. patent application Ser. No. 16/024,160, titled VARIABLE OUTPUT CARTRIDGE SENSOR ASSEMBLY;
- [0149] U.S. patent application Ser. No. 16/024,124, titled SURGICAL INSTRUMENT HAVING A FLEXIBLE ELECTRODE;
- [0150] U.S. patent application Ser. No. 16/024,132, titled SURGICAL INSTRUMENT HAVING A FLEXIBLE CIRCUIT;
- [0151] U.S. patent application Ser. No. 16/024,141, titled SURGICAL INSTRUMENT WITH A TISSUE MARKING ASSEMBLY;
- [0152] U.S. patent application Ser. No. 16/024,162, titled SURGICAL SYSTEMS WITH PRIORITIZED DATA TRANSMISSION CAPABILITIES;
- [0153] U.S. patent application Ser. No. 16/024,066, titled SURGICAL EVACUATION SENSING AND MOTOR CONTROL;
- [0154] U.S. patent application Ser. No. 16/024,096, titled SURGICAL EVACUATION SENSOR ARRANGEMENTS;
- [0155] U.S. patent application Ser. No. 16/024,116, titled SURGICAL EVACUATION FLOW PATHS;
- [0156] U.S. patent application Ser. No. 16/024,149, titled SURGICAL EVACUATION SENSING AND GENERATOR CONTROL;
- [0157] U.S. patent application Ser. No. 16/024,180, titled SURGICAL EVACUATION SENSING AND DISPLAY;
- [0158] U.S. patent application Ser. No. 16/024,245, titled COMMUNICATION OF SMOKE EVACUATION SYSTEM PARAMETERS TO HUB OR

CLOUD IN SMOKE EVACUATION MODULE FOR INTERACTIVE SURGICAL PLATFORM;

- [0159] U.S. patent application Ser. No. 16/024,258, titled SMOKE EVACUATION SYSTEM INCLUDING A SEGMENTED CONTROL CIRCUIT FOR INTERACTIVE SURGICAL PLATFORM;
 - [0160] U.S. patent application Ser. No. 16/024,265, titled SURGICAL EVACUATION SYSTEM WITH A COMMUNICATION CIRCUIT FOR COMMUNICATION BETWEEN A FILTER AND A SMOKE EVACUATION DEVICE; and
 - [0161] U.S. patent application Ser. No. 16/024,273, titled DUAL IN-SERIES LARGE AND SMALL DROPLET FILTERS.
- [0162] Applicant of the present application owns the following U.S. Provisional patent applications, filed on Jun. 28, 2018, the disclosure of each of which is herein incorporated by reference in its entirety:
- [0163] U.S. Provisional Patent Application Ser. No. 62/691,228, titled A METHOD OF USING REINFORCED FLEX CIRCUITS WITH MULTIPLE SENSORS WITH ELECTROSURGICAL DEVICES;
 - [0164] U.S. Provisional Patent Application Ser. No. 62/691,227, titled CONTROLLING A SURGICAL INSTRUMENT ACCORDING TO SENSED CLOSURE PARAMETERS;
 - [0165] U.S. Provisional Patent Application Ser. No. 62/691,230, titled SURGICAL INSTRUMENT HAVING A FLEXIBLE ELECTRODE;
 - [0166] U.S. Provisional Patent Application Ser. No. 62/691,219, titled SURGICAL EVACUATION SENSING AND MOTOR CONTROL;
 - [0167] U.S. Provisional Patent Application Ser. No. 62/691,257, titled COMMUNICATION OF SMOKE EVACUATION SYSTEM PARAMETERS TO HUB OR CLOUD IN SMOKE EVACUATION MODULE FOR INTERACTIVE SURGICAL PLATFORM;
 - [0168] U.S. Provisional Patent Application Ser. No. 62/691,262, titled SURGICAL EVACUATION SYSTEM WITH A COMMUNICATION CIRCUIT FOR COMMUNICATION BETWEEN A FILTER AND A SMOKE EVACUATION DEVICE; and
 - [0169] U.S. Provisional Patent Application Ser. No. 62/691,251, titled DUAL IN-SERIES LARGE AND SMALL DROPLET FILTERS.
- [0170] Applicant of the present application owns the following U.S. Provisional patent application, filed on Apr. 19, 2018, the disclosure of each of which is herein incorporated by reference in its entirety:
- [0171] U.S. Provisional Patent Application Ser. No. 62/659,900, titled METHOD OF HUB COMMUNICATION.
- [0172] Applicant of the present application owns the following U.S. Provisional patent applications, filed on Mar. 30, 2018, the disclosure of each of which is herein incorporated by reference in its entirety:
- [0173] U.S. Provisional Patent Application No. 62/650,898 filed on Mar. 30, 2018, titled CAPACITIVE COUPLED RETURN PATH PAD WITH SEPARABLE ARRAY ELEMENTS;
 - [0174] U.S. Provisional Patent Application Ser. No. 62/650,887, titled SURGICAL SYSTEMS WITH OPTIMIZED SENSING CAPABILITIES;

- [0175] U.S. Provisional Patent Application Ser. No. 62/650,882, titled SMOKE EVACUATION MODULE FOR INTERACTIVE SURGICAL PLATFORM; and
- [0176] U.S. Provisional Patent Application Ser. No. 62/650,877, titled SURGICAL SMOKE EVACUATION SENSING AND CONTROLS
- [0177] Applicant of the present application owns the following U.S. patent applications, filed on Mar. 29, 2018, the disclosure of each of which is herein incorporated by reference in its entirety:
- [0178] U.S. patent application Ser. No. 15/940,641, titled INTERACTIVE SURGICAL SYSTEMS WITH ENCRYPTED COMMUNICATION CAPABILITIES;
- [0179] U.S. patent application Ser. No. 15/940,648, titled INTERACTIVE SURGICAL SYSTEMS WITH CONDITION HANDLING OF DEVICES AND DATA CAPABILITIES;
- [0180] U.S. patent application Ser. No. 15/940,656, titled SURGICAL HUB COORDINATION OF CONTROL AND COMMUNICATION OF OPERATING ROOM DEVICES;
- [0181] U.S. patent application Ser. No. 15/940,666, titled SPATIAL AWARENESS OF SURGICAL HUBS IN OPERATING ROOMS;
- [0182] U.S. patent application Ser. No. 15/940,670, titled COOPERATIVE UTILIZATION OF DATA DERIVED FROM SECONDARY SOURCES BY INTELLIGENT SURGICAL HUBS;
- [0183] U.S. patent application Ser. No. 15/940,677, titled SURGICAL HUB CONTROL ARRANGEMENTS;
- [0184] U.S. patent application Ser. No. 15/940,632, titled DATA STRIPPING METHOD TO INTERROGATE PATIENT RECORDS AND CREATE ANONYMIZED RECORD;
- [0185] U.S. patent application Ser. No. 15/940,640, titled COMMUNICATION HUB AND STORAGE DEVICE FOR STORING PARAMETERS AND STATUS OF A SURGICAL DEVICE TO BE SHARED WITH CLOUD BASED ANALYTICS SYSTEMS;
- [0186] U.S. patent application Ser. No. 15/940,645, titled SELF DESCRIBING DATA PACKETS GENERATED AT AN ISSUING INSTRUMENT;
- [0187] U.S. patent application Ser. No. 15/940,649, titled DATA PAIRING TO INTERCONNECT A DEVICE MEASURED PARAMETER WITH AN OUTCOME;
- [0188] U.S. patent application Ser. No. 15/940,654, titled SURGICAL HUB SITUATIONAL AWARENESS;
- [0189] U.S. patent application Ser. No. 15/940,663, titled SURGICAL SYSTEM DISTRIBUTED PROCESSING;
- [0190] U.S. patent application Ser. No. 15/940,668, titled AGGREGATION AND REPORTING OF SURGICAL HUB DATA;
- [0191] U.S. patent application Ser. No. 15/940,671, titled SURGICAL HUB SPATIAL AWARENESS TO DETERMINE DEVICES IN OPERATING THEATER;
- [0192] U.S. patent application Ser. No. 15/940,686, titled DISPLAY OF ALIGNMENT OF STAPLE CARTRIDGE TO PRIOR LINEAR STAPLE LINE;
- [0193] U.S. patent application Ser. No. 15/940,700, titled STERILE FIELD INTERACTIVE CONTROL DISPLAYS;
- [0194] U.S. patent application Ser. No. 15/940,629, titled COMPUTER IMPLEMENTED INTERACTIVE SURGICAL SYSTEMS;
- [0195] U.S. patent application Ser. No. 15/940,704, titled USE OF LASER LIGHT AND RED-GREEN-BLUE COLORATION TO DETERMINE PROPERTIES OF BACK SCATTERED LIGHT;
- [0196] U.S. patent application Ser. No. 15/940,722, titled CHARACTERIZATION OF TISSUE IRREGULARITIES THROUGH THE USE OF MONO-CHROMATIC LIGHT REFRACTIVITY; and
- [0197] U.S. patent application Ser. No. 15/940,742, titled DUAL CMOS ARRAY IMAGING.
- [0198] U.S. patent application Ser. No. 15/940,636, titled ADAPTIVE CONTROL PROGRAM UPDATES FOR SURGICAL DEVICES;
- [0199] U.S. patent application Ser. No. 15/940,653, titled ADAPTIVE CONTROL PROGRAM UPDATES FOR SURGICAL HUBS;
- [0200] U.S. patent application Ser. No. 15/940,660, titled CLOUD-BASED MEDICAL ANALYTICS FOR CUSTOMIZATION AND RECOMMENDATIONS TO A USER;
- [0201] U.S. patent application Ser. No. 15/940,679, titled CLOUD-BASED MEDICAL ANALYTICS FOR LINKING OF LOCAL USAGE TRENDS WITH THE RESOURCE ACQUISITION BEHAVIORS OF LARGER DATA SET;
- [0202] U.S. patent application Ser. No. 15/940,694, titled CLOUD-BASED MEDICAL ANALYTICS FOR MEDICAL FACILITY SEGMENTED INDIVIDUALIZATION OF INSTRUMENT FUNCTION;
- [0203] U.S. patent application Ser. No. 15/940,634, titled CLOUD-BASED MEDICAL ANALYTICS FOR SECURITY AND AUTHENTICATION TRENDS AND REACTIVE MEASURES;
- [0204] U.S. patent application Ser. No. 15/940,706, titled DATA HANDLING AND PRIORITIZATION IN A CLOUD ANALYTICS NETWORK; and
- [0205] U.S. patent application Ser. No. 15/940,675, titled CLOUD INTERFACE FOR COUPLED SURGICAL DEVICES.
- [0206] U.S. patent application Ser. No. 15/940,627, titled DRIVE ARRANGEMENTS FOR ROBOT-ASSISTED SURGICAL PLATFORMS;
- [0207] U.S. patent application Ser. No. 15/940,637, titled COMMUNICATION ARRANGEMENTS FOR ROBOT-ASSISTED SURGICAL PLATFORMS;
- [0208] U.S. patent application Ser. No. 15/940,642, titled CONTROLS FOR ROBOT-ASSISTED SURGICAL PLATFORMS;
- [0209] U.S. patent application Ser. No. 15/940,676, titled AUTOMATIC TOOL ADJUSTMENTS FOR ROBOT-ASSISTED SURGICAL PLATFORMS;
- [0210] U.S. patent application Ser. No. 15/940,680, titled CONTROLLERS FOR ROBOT-ASSISTED SURGICAL PLATFORMS;
- [0211] U.S. patent application Ser. No. 15/940,683, titled COOPERATIVE SURGICAL ACTIONS FOR ROBOT-ASSISTED SURGICAL PLATFORMS;

- [0212] U.S. patent application Ser. No. 15/940,690, titled DISPLAY ARRANGEMENTS FOR ROBOT-ASSISTED SURGICAL PLATFORMS; and
- [0213] U.S. patent application Ser. No. 15/940,711, titled SENSING ARRANGEMENTS FOR ROBOT-ASSISTED SURGICAL PLATFORMS.
- [0214] Applicant of the present application owns the following U.S. Provisional patent applications, filed on Mar. 28, 2018, the disclosure of each of which is herein incorporated by reference in its entirety:
- [0215] U.S. Provisional Patent Application Ser. No. 62/649,302, titled INTERACTIVE SURGICAL SYSTEMS WITH ENCRYPTED COMMUNICATION CAPABILITIES;
- [0216] U.S. Provisional Patent Application Ser. No. 62/649,294, titled DATA STRIPPING METHOD TO INTERROGATE PATIENT RECORDS AND CREATE ANONYMIZED RECORD;
- [0217] U.S. Provisional Patent Application Ser. No. 62/649,300, titled SURGICAL HUB SITUATIONAL AWARENESS;
- [0218] U.S. Provisional Patent Application Ser. No. 62/649,309, titled SURGICAL HUB SPATIAL AWARENESS TO DETERMINE DEVICES IN OPERATING THEATER;
- [0219] U.S. Provisional Patent Application Ser. No. 62/649,310, titled COMPUTER IMPLEMENTED INTERACTIVE SURGICAL SYSTEMS;
- [0220] U.S. Provisional Patent Application Ser. No. 62/649,291, titled USE OF LASER LIGHT AND RED-GREEN-BLUE COLORATION TO DETERMINE PROPERTIES OF BACK SCATTERED LIGHT;
- [0221] U.S. Provisional Patent Application Ser. No. 62/649,296, titled ADAPTIVE CONTROL PROGRAM UPDATES FOR SURGICAL DEVICES;
- [0222] U.S. Provisional Patent Application Ser. No. 62/649,333, titled CLOUD-BASED MEDICAL ANALYTICS FOR CUSTOMIZATION AND RECOMMENDATIONS TO A USER;
- [0223] U.S. Provisional Patent Application Ser. No. 62/649,327, titled CLOUD-BASED MEDICAL ANALYTICS FOR SECURITY AND AUTHENTICATION TRENDS AND REACTIVE MEASURES;
- [0224] U.S. Provisional Patent Application Ser. No. 62/649,315, titled DATA HANDLING AND PRIORITIZATION IN A CLOUD ANALYTICS NETWORK;
- [0225] U.S. Provisional Patent Application Ser. No. 62/649,313, titled CLOUD INTERFACE FOR COUPLED SURGICAL DEVICES;
- [0226] U.S. Provisional Patent Application Ser. No. 62/649,320, titled DRIVE ARRANGEMENTS FOR ROBOT-ASSISTED SURGICAL PLATFORMS;
- [0227] U.S. Provisional Patent Application Ser. No. 62/649,307, titled AUTOMATIC TOOL ADJUSTMENTS FOR ROBOT-ASSISTED SURGICAL PLATFORMS; and
- [0228] U.S. Provisional Patent Application Ser. No. 62/649,323, titled SENSING ARRANGEMENTS FOR ROBOT-ASSISTED SURGICAL PLATFORMS.
- [0229] Applicant of the present application owns the following U.S. Provisional patent applications, filed on Mar. 8, 2018, the disclosure of each of which is herein incorporated by reference in its entirety:
- [0230] U.S. Provisional Patent Application Ser. No. 62/640,417, titled TEMPERATURE CONTROL IN ULTRASONIC DEVICE AND CONTROL SYSTEM THEREFOR; and
- [0231] U.S. Provisional Patent Application Ser. No. 62/640,415, titled ESTIMATING STATE OF ULTRASONIC END EFFECTOR AND CONTROL SYSTEM THEREFOR.
- [0232] Applicant of the present application owns the following U.S. Provisional patent applications, filed on Dec. 28, 2017, the disclosure of each of which is herein incorporated by reference in its entirety:
- [0233] U.S. Provisional Patent Application Serial No. U.S. Provisional Patent Application Ser. No. 62/611,341, titled INTERACTIVE SURGICAL PLATFORM;
- [0234] U.S. Provisional Patent Application Ser. No. 62/611,340, titled CLOUD-BASED MEDICAL ANALYTICS; and
- [0235] U.S. Provisional Patent Application Ser. No. 62/611,339, titled ROBOT ASSISTED SURGICAL PLATFORM.
- [0236] Before explaining various aspects of surgical devices and generators in detail, it should be noted that the illustrative examples are not limited in application or use to the details of construction and arrangement of parts illustrated in the accompanying drawings and description. The illustrative examples may be implemented or incorporated in other aspects, variations and modifications, and may be practiced or carried out in various ways. Further, unless otherwise indicated, the terms and expressions employed herein have been chosen for the purpose of describing the illustrative examples for the convenience of the reader and are not for the purpose of limitation thereof. Also, it will be appreciated that one or more of the following-described aspects, expressions of aspects, and/or examples, can be combined with any one or more of the other following-described aspects, expressions of aspects and/or examples.
- [0237] Various aspects are directed to improved ultrasonic surgical devices, electrosurgical devices and generators for use therewith. Aspects of the ultrasonic surgical devices can be configured for transecting and/or coagulating tissue during surgical procedures, for example. Aspects of the electrosurgical devices can be configured for transecting, coagulating, scaling, welding and/or desiccating tissue during surgical procedures, for example.
- [0238] Referring to FIG. 1, a computer-implemented interactive surgical system 100 includes one or more surgical systems 102 and a cloud-based system (e.g., the cloud 104 that may include a remote server 113 coupled to a storage device 105). Each surgical system 102 includes at least one surgical hub 106 in communication with the cloud 104 that may include a remote server 113. In one example, as illustrated in FIG. 1, the surgical system 102 includes a visualization system 108, a robotic system 110, and a handheld intelligent surgical instrument 112, which are configured to communicate with one another and/or the hub 106. In some aspects, a surgical system 102 may include an M number of hubs 106, an N number of visualization systems 108, an O number of robotic systems 110, and a P number of handheld intelligent surgical instruments 112, where M, N, O, and P are integers greater than or equal to one.
- [0239] FIG. 3 depicts an example of a surgical system 102 being used to perform a surgical procedure on a patient who

is lying down on an operating table **114** in a surgical operating room **116**. A robotic system **110** is used in the surgical procedure as a part of the surgical system **102**. The robotic system **110** includes a surgeon's console **118**, a patient side cart **120** (surgical robot), and a surgical robotic hub **122**. The patient side cart **120** can manipulate at least one removably coupled surgical tool **117** through a minimally invasive incision in the body of the patient while the surgeon views the surgical site through the surgeon's console **118**. An image of the surgical site can be obtained by a medical imaging device **124**, which can be manipulated by the patient side cart **120** to orient the imaging device **124**. The robotic hub **122** can be used to process the images of the surgical site for subsequent display to the surgeon through the surgeon's console **118**.

[0240] Other types of robotic systems can be readily adapted for use with the surgical system **102**. Various examples of robotic systems and surgical tools that are suitable for use with the present disclosure are described in U.S. Provisional Patent Application Ser. No. 62/611,339, titled ROBOT ASSISTED SURGICAL PLATFORM, filed Dec. 28, 2017, the disclosure of which is herein incorporated by reference in its entirety.

[0241] Various examples of cloud-based analytics that are performed by the cloud **104**, and are suitable for use with the present disclosure, are described in U.S. Provisional Patent Application Ser. No. 62/611,340, titled CLOUD-BASED MEDICAL ANALYTICS, filed Dec. 28, 2017, the disclosure of which is herein incorporated by reference in its entirety.

[0242] In various aspects, the imaging device **124** includes at least one image sensor and one or more optical components. Suitable image sensors include, but are not limited to, Charge-Coupled Device (CCD) sensors and Complementary Metal-Oxide Semiconductor (CMOS) sensors.

[0243] The optical components of the imaging device **124** may include one or more illumination sources and/or one or more lenses. The one or more illumination sources may be directed to illuminate portions of the surgical field. The one or more image sensors may receive light reflected or refracted from the surgical field, including light reflected or refracted from tissue and/or surgical instruments.

[0244] The one or more illumination sources may be configured to radiate electromagnetic energy in the visible spectrum as well as the invisible spectrum. The visible spectrum, sometimes referred to as the optical spectrum or luminous spectrum, is that portion of the electromagnetic spectrum that is visible to (i.e., can be detected by) the human eye and may be referred to as visible light or simply light. A typical human eye will respond to wavelengths in air that are from about 380 nm to about 750 nm.

[0245] The invisible spectrum (i.e., the non-luminous spectrum) is that portion of the electromagnetic spectrum that lies below and above the visible spectrum (i.e., wavelengths below about 380 nm and above about 750 nm). The invisible spectrum is not detectable by the human eye. Wavelengths greater than about 750 nm are longer than the red visible spectrum, and they become invisible infrared (IR), microwave, and radio electromagnetic radiation. Wavelengths less than about 380 nm are shorter than the violet spectrum, and they become invisible ultraviolet, x-ray, and gamma ray electromagnetic radiation.

[0246] In various aspects, the imaging device **124** is configured for use in a minimally invasive procedure.

Examples of imaging devices suitable for use with the present disclosure include, but not limited to, an arthroscope, angioscope, bronchoscope, choledochoscope, colonoscope, cytoscope, duodenoscope, enteroscope, esophagogastro-duodenoscope (gastroscope), endoscope, laryngoscope, nasopharyngo-neproscope, sigmoidoscope, thoracoscope, and ureteroscope.

[0247] In one aspect, the imaging device employs multi-spectrum monitoring to discriminate topography and underlying structures. A multi-spectral image is one that captures image data within specific wavelength ranges across the electromagnetic spectrum. The wavelengths may be separated by filters or by the use of instruments that are sensitive to particular wavelengths, including light from frequencies beyond the visible light range, e.g., IR and ultraviolet. Spectral imaging can allow extraction of additional information the human eye fails to capture with its receptors for red, green, and blue. The use of multi-spectral imaging is described in greater detail under the heading "Advanced Imaging Acquisition Module" in U.S. Provisional Patent Application Ser. No. 62/611,341, titled INTERACTIVE SURGICAL PLATFORM, filed Dec. 28, 2017, the disclosure of which is herein incorporated by reference in its entirety. Multi-spectrum monitoring can be a useful tool in relocating a surgical field after a surgical task is completed to perform one or more of the previously described tests on the treated tissue.

[0248] It is axiomatic that strict sterilization of the operating room and surgical equipment is required during any surgery. The strict hygiene and sterilization conditions required in a "surgical theater," i.e., an operating or treatment room, necessitate the highest possible sterility of all medical devices and equipment. Part of that sterilization process is the need to sterilize anything that comes in contact with the patient or penetrates the sterile field, including the imaging device **124** and its attachments and components. It will be appreciated that the sterile field may be considered a specified area, such as within a tray or on a sterile towel, that is considered free of microorganisms, or the sterile field may be considered an area, immediately around a patient, who has been prepared for a surgical procedure. The sterile field may include the scrubbed team members, who are properly attired, and all furniture and fixtures in the area.

[0249] In various aspects, the visualization system **108** includes one or more imaging sensors, one or more image-processing units, one or more storage arrays, and one or more displays that are strategically arranged with respect to the sterile field, as illustrated in FIG. 2. In one aspect, the visualization system **108** includes an interface for HL7, PACS, and EMR. Various components of the visualization system **108** are described under the heading "Advanced Imaging Acquisition Module" in U.S. Provisional Patent Application Ser. No. 62/611,341, titled INTERACTIVE SURGICAL PLATFORM, filed Dec. 28, 2017, the disclosure of which is herein incorporated by reference in its entirety.

[0250] As illustrated in FIG. 2, a primary display **119** is positioned in the sterile field to be visible to an operator at the operating table **114**. In addition, a visualization tower **111** is positioned outside the sterile field. The visualization tower **111** includes a first non-sterile display **107** and a second non-sterile display **109**, which face away from each other. The visualization system **108**, guided by the hub **106**, is configured to utilize the displays **107**, **109**, and **119** to

coordinate information flow to operators inside and outside the sterile field. For example, the hub **106** may cause the visualization system **108** to display a snapshot of a surgical site, as recorded by an imaging device **124**, on a non-sterile display **107** or **109**, while maintaining a live feed of the surgical site on the primary display **119**. The snapshot on the non-sterile display **107** or **109** can permit a non-sterile operator to perform a diagnostic step relevant to the surgical procedure, for example.

[0251] In one aspect, the hub **106** is also configured to route a diagnostic input or feedback entered by a non-sterile operator at the visualization tower **111** to the primary display **119** within the sterile field, where it can be viewed by a sterile operator at the operating table. In one example, the input can be in the form of a modification to the snapshot displayed on the non-sterile display **107** or **109**, which can be routed to the primary display **119** by the hub **106**.

[0252] Referring to FIG. 2, a surgical instrument **112** is being used in the surgical procedure as part of the surgical system **102**. The hub **106** is also configured to coordinate information flow to a display of the surgical instrument **112**. For example, in U.S. Provisional Patent Application Ser. No. 62/611,341, titled INTERACTIVE SURGICAL PLATFORM, filed Dec. 28, 2017, the disclosure of which is herein incorporated by reference in its entirety. A diagnostic input or feedback entered by a non-sterile operator at the visualization tower **111** can be routed by the hub **106** to the surgical instrument display **115** within the sterile field, where it can be viewed by the operator of the surgical instrument **112**. Example surgical instruments that are suitable for use with the surgical system **102** are described under the heading “Surgical Instrument Hardware” and in U.S. Provisional Patent Application Ser. No. 62/611,341, titled INTERACTIVE SURGICAL PLATFORM, filed Dec. 28, 2017, the disclosure of which is herein incorporated by reference in its entirety, for example.

[0253] Referring now to FIG. 3, a hub **106** is depicted in communication with a visualization system **108**, a robotic system **110**, and a handheld intelligent surgical instrument **112**. The hub **106** includes a hub display **135**, an imaging module **138**, a generator module **140**, a communication module **130**, a processor module **132**, and a storage array **134**. In certain aspects, as illustrated in FIG. 3, the hub **106** further includes a smoke evacuation module **126** and/or a suction/irrigation module **128**.

[0254] During a surgical procedure, energy application to tissue, for sealing and/or cutting, is generally associated with smoke evacuation, suction of excess fluid, and/or irrigation of the tissue. Fluid, power, and/or data lines from different sources are often entangled during the surgical procedure. Valuable time can be lost addressing this issue during a surgical procedure. Detangling the lines may necessitate disconnecting the lines from their respective modules, which may require resetting the modules. The hub modular enclosure **136** offers a unified environment for managing the power, data, and fluid lines, which reduces the frequency of entanglement between such lines.

[0255] Aspects of the present disclosure present a surgical hub for use in a surgical procedure that involves energy application to tissue at a surgical site. The surgical hub includes a hub enclosure and a combo generator module slidably receivable in a docking station of the hub enclosure. The docking station includes data and power contacts. The combo generator module includes two or more of an ultra-

sonic energy generator component, a bipolar RF energy generator component, and a monopolar RF energy generator component that are housed in a single unit. In one aspect, the combo generator module also includes a smoke evacuation component, at least one energy delivery cable for connecting the combo generator module to a surgical instrument, at least one smoke evacuation component configured to evacuate smoke, fluid, and/or particulates generated by the application of therapeutic energy to the tissue, and a fluid line extending from the remote surgical site to the smoke evacuation component.

[0256] In one aspect, the fluid line is a first fluid line and a second fluid line extends from the remote surgical site to a suction and irrigation module slidably received in the hub enclosure. In one aspect, the hub enclosure comprises a fluid interface.

[0257] Certain surgical procedures may require the application of more than one energy type to the tissue. One energy type may be more beneficial for cutting the tissue, while another different energy type may be more beneficial for sealing the tissue. For example, a bipolar generator can be used to seal the tissue while an ultrasonic generator can be used to cut the sealed tissue. Aspects of the present disclosure present a solution where a hub modular enclosure **136** is configured to accommodate different generators, and facilitate an interactive communication therebetween. One of the advantages of the hub modular enclosure **136** is enabling the quick removal and/or replacement of various modules.

[0258] Aspects of the present disclosure present a modular surgical enclosure for use in a surgical procedure that involves energy application to tissue. The modular surgical enclosure includes a first energy-generator module, configured to generate a first energy for application to the tissue, and a first docking station comprising a first docking port that includes first data and power contacts, wherein the first energy-generator module is slidably movable into an electrical engagement with the power and data contacts and wherein the first energy-generator module is slidably movable out of the electrical engagement with the first power and data contacts,

[0259] Further to the above, the modular surgical enclosure also includes a second energy-generator module configured to generate a second energy, different than the first energy, for application to the tissue, and a second docking station comprising a second docking port that includes second data and power contacts, wherein the second energy-generator module is slidably movable into an electrical engagement with the power and data contacts, and wherein the second energy-generator module is slidably movable out of the electrical engagement with the second power and data contacts.

[0260] In addition, the modular surgical enclosure also includes a communication bus between the first docking port and the second docking port, configured to facilitate communication between the first energy-generator module and the second energy-generator module.

[0261] Referring to FIGS. 3-7, aspects of the present disclosure are presented for a hub modular enclosure **136** that allows the modular integration of a generator module **140**, a smoke evacuation module **126**, and a suction/irrigation module **128**. The hub modular enclosure **136** further facilitates interactive communication between the modules **140**, **126**, **128**. As illustrated in FIG. 5, the generator module

140 can be a generator module with integrated monopolar, bipolar, and ultrasonic components supported in a single housing unit **139** slidably insertable into the hub modular enclosure **136**. As illustrated in FIG. 5, the generator module **140** can be configured to connect to a monopolar device **146**, a bipolar device **147**, and an ultrasonic device **148**. Alternatively, the generator module **140** may comprise a series of monopolar, bipolar, and/or ultrasonic generator modules that interact through the hub modular enclosure **136**. The hub modular enclosure **136** can be configured to facilitate the insertion of multiple generators and interactive communication between the generators docked into the hub modular enclosure **136** so that the generators would act as a single generator.

[0262] In one aspect, the hub modular enclosure **136** comprises a modular power and communication backplane **149** with external and wireless communication headers to enable the removable attachment of the modules **140**, **126**, **128** and interactive communication therebetween.

[0263] In one aspect, the hub modular enclosure **136** includes docking stations, or drawers, **151**, herein also referred to as drawers, which are configured to slidably receive the modules **140**, **126**, **128**. FIG. 4 illustrates a partial perspective view of a surgical hub enclosure **136**, and a combo generator module **145** slidably receivable in a docking station **151** of the surgical hub enclosure **136**. A docking port **152** with power and data contacts on a rear side of the combo generator module **145** is configured to engage a corresponding docking port **150** with power and data contacts of a corresponding docking station **151** of the hub modular enclosure **136** as the combo generator module **145** is slid into position within the corresponding docking station **151** of the hub module enclosure **136**. In one aspect, the combo generator module **145** includes a bipolar, ultrasonic, and monopolar module and a smoke evacuation module integrated together into a single housing unit **139**, as illustrated in FIG. 5.

[0264] In various aspects, the smoke evacuation module **126** includes a fluid line **154** that conveys captured/collected smoke and/or fluid away from a surgical site and to, for example, the smoke evacuation module **126**. Vacuum suction originating from the smoke evacuation module **126** can draw the smoke into an opening of a utility conduit at the surgical site. The utility conduit, coupled to the fluid line, can be in the form of a flexible tube terminating at the smoke evacuation module **126**. The utility conduit and the fluid line define a fluid path extending toward the smoke evacuation module **126** that is received in the hub enclosure **136**.

[0265] In various aspects, the suction/irrigation module **128** is coupled to a surgical tool comprising an aspiration fluid line and a suction fluid line. In one example, the aspiration and suction fluid lines are in the form of flexible tubes extending from the surgical site toward the suction/irrigation module **128**. One or more drive systems can be configured to cause irrigation and aspiration of fluids to and from the surgical site.

[0266] In one aspect, the surgical tool includes a shaft having an end effector at a distal end thereof and at least one energy treatment associated with the end effector, an aspiration tube, and an irrigation tube. The aspiration tube can have an inlet port at a distal end thereof and the aspiration tube extends through the shaft. Similarly, an irrigation tube can extend through the shaft and can have an inlet port in proximity to the energy deliver implement. The energy

deliver implement is configured to deliver ultrasonic and/or RF energy to the surgical site and is coupled to the generator module **140** by a cable extending initially through the shaft. [0267] The irrigation tube can be in fluid communication with a fluid source, and the aspiration tube can be in fluid communication with a vacuum source. The fluid source and/or the vacuum source can be housed in the suction/irrigation module **128**. In one example, the fluid source and/or the vacuum source can be housed in the hub enclosure **136** separately from the suction/irrigation module **128**. In such example, a fluid interface can be configured to connect the suction/irrigation module **128** to the fluid source and/or the vacuum source.

[0268] In one aspect, the modules **140**, **126**, **128** and/or their corresponding docking stations on the hub modular enclosure **136** may include alignment features that are configured to align the docking ports of the modules into engagement with their counterparts in the docking stations of the hub modular enclosure **136**. For example, as illustrated in FIG. 4, the combo generator module **145** includes side brackets **155** that are configured to slidably engage with corresponding brackets **156** of the corresponding docking station **151** of the hub modular enclosure **136**. The brackets cooperate to guide the docking port contacts of the combo generator module **145** into an electrical engagement with the docking port contacts of the hub modular enclosure **136**.

[0269] In some aspects, the drawers **151** of the hub modular enclosure **136** are the same, or substantially the same size, and the modules are adjusted in size to be received in the drawers **151**. For example, the side brackets **155** and/or **156** can be larger or smaller depending on the size of the module. In other aspects, the drawers **151** are different in size and are each designed to accommodate a particular module.

[0270] Furthermore, the contacts of a particular module can be keyed for engagement with the contacts of a particular drawer to avoid inserting a module into a drawer with mismatching contacts.

[0271] As illustrated in FIG. 4, the docking port **150** of one drawer **151** can be coupled to the docking port **150** of another drawer **151** through a communications link **157** to facilitate an interactive communication between the modules housed in the hub modular enclosure **136**. The docking ports **150** of the hub modular enclosure **136** may alternatively, or additionally, facilitate a wireless interactive communication between the modules housed in the hub modular enclosure **136**. Any suitable wireless communication can be employed, such as for example Air Titan-Bluetooth.

[0272] FIG. 6 illustrates individual power bus attachments for a plurality of lateral docking ports of a lateral modular housing **160** configured to receive a plurality of modules of a surgical hub **206**. The lateral modular housing **160** is configured to laterally receive and interconnect the modules **161**. The modules **161** are slidably inserted into docking stations **162** of lateral modular housing **160**, which includes a backplane for interconnecting the modules **161**. As illustrated in FIG. 6, the modules **161** are arranged laterally in the lateral modular housing **160**. Alternatively, the modules **161** may be arranged vertically in a lateral modular housing.

[0273] FIG. 7 illustrates a vertical modular housing **164** configured to receive a plurality of modules **165** of the surgical hub **106**. The modules **165** are slidably inserted into docking stations, or drawers, **167** of vertical modular housing **164**, which includes a backplane for interconnecting the

modules 165. Although the drawers 167 of the vertical modular housing 164 are arranged vertically, in certain instances, a vertical modular housing 164 may include drawers that are arranged laterally. Furthermore, the modules 165 may interact with one another through the docking ports of the vertical modular housing 164. In the example of FIG. 7, a display 177 is provided for displaying data relevant to the operation of the modules 165. In addition, the vertical modular housing 164 includes a master module 178 housing a plurality of sub-modules that are slidably received in the master module 178.

[0274] In various aspects, the imaging module 138 comprises an integrated video processor and a modular light source and is adapted for use with various imaging devices. In one aspect, the imaging device is comprised of a modular housing that can be assembled with a light source module and a camera module. The housing can be a disposable housing. In at least one example, the disposable housing is removably coupled to a reusable controller, a light source module, and a camera module. The light source module and/or the camera module can be selectively chosen depending on the type of surgical procedure. In one aspect, the camera module comprises a CCD sensor. In another aspect, the camera module comprises a CMOS sensor. In another aspect, the camera module is configured for scanned beam imaging. Likewise, the light source module can be configured to deliver a white light or a different light, depending on the surgical procedure.

[0275] During a surgical procedure, removing a surgical device from the surgical field and replacing it with another surgical device that includes a different camera or a different light source can be inefficient. Temporarily losing sight of the surgical field may lead to undesirable consequences. The module imaging device of the present disclosure is configured to permit the replacement of a light source module or a camera module midstream during a surgical procedure, without having to remove the imaging device from the surgical field.

[0276] In one aspect, the imaging device comprises a tubular housing that includes a plurality of channels. A first channel is configured to slidably receive the camera module, which can be configured for a snap-fit engagement with the first channel. A second channel is configured to slidably receive the light source module, which can be configured for a snap-fit engagement with the second channel. In another example, the camera module and/or the light source module can be rotated into a final position within their respective channels. A threaded engagement can be employed in lieu of the snap-fit engagement.

[0277] In various examples, multiple imaging devices are placed at different positions in the surgical field to provide multiple views. The imaging module 138 can be configured to switch between the imaging devices to provide an optimal view. In various aspects, the imaging module 138 can be configured to integrate the images from the different imaging device.

[0278] Various image processors and imaging devices suitable for use with the present disclosure are described in U.S. Pat. No. 7,995,045, titled COMBINED SBI AND CONVENTIONAL IMAGE PROCESSOR, which issued on Aug. 9, 2011, which is herein incorporated by reference in its entirety. In addition, U.S. Pat. No. 7,982,776, titled SBI MOTION ARTIFACT REMOVAL APPARATUS AND METHOD, which issued on Jul. 19, 2011, which is herein

incorporated by reference in its entirety, describes various systems for removing motion artifacts from image data. Such systems can be integrated with the imaging module 138. Furthermore, U.S. Patent Application Publication No. 2011/0306840, titled CONTROLLABLE MAGNETIC SOURCE TO FIXTURE INTRACORPOREAL APPARATUS, which published on Dec. 15, 2011, and U.S. Patent Application Publication No. 2014/0243597, titled SYSTEM FOR PERFORMING A MINIMALLY INVASIVE SURGICAL PROCEDURE, which published on Aug. 28, 2014, each of which is herein incorporated by reference in its entirety.

[0279] FIG. 8 illustrates a surgical data network 201 comprising a modular communication hub 203 configured to connect modular devices located in one or more operating theaters of a healthcare facility, or any room in a healthcare facility specially equipped for surgical operations, to a cloud-based system (e.g., the cloud 204 that may include a remote server 213 coupled to a storage device 205). In one aspect, the modular communication hub 203 comprises a network hub 207 and/or a network switch 209 in communication with a network router. The modular communication hub 203 also can be coupled to a local computer system 210 to provide local computer processing and data manipulation. The surgical data network 201 may be configured as passive, intelligent, or switching. A passive surgical data network serves as a conduit for the data, enabling it to go from one device (or segment) to another and to the cloud computing resources. An intelligent surgical data network includes additional features to enable the traffic passing through the surgical data network to be monitored and to configure each port in the network hub 207 or network switch 209. An intelligent surgical data network may be referred to as a manageable hub or switch. A switching hub reads the destination address of each packet and then forwards the packet to the correct port.

[0280] Modular devices 1a-1n located in the operating theater may be coupled to the modular communication hub 203. The network hub 207 and/or the network switch 209 may be coupled to a network router 211 to connect the devices 1a-1n to the cloud 204 or the local computer system 210. Data associated with the devices 1a-1n may be transferred to cloud-based computers via the router for remote data processing and manipulation. Data associated with the devices 1a-1n may also be transferred to the local computer system 210 for local data processing and manipulation. Modular devices 2a-2m located in the same operating theater also may be coupled to a network switch 209. The network switch 209 may be coupled to the network hub 207 and/or the network router 211 to connect to the devices 2a-2m to the cloud 204. Data associated with the devices 2a-2m may be transferred to the cloud 204 via the network router 211 for data processing and manipulation. Data associated with the devices 2a-2m may also be transferred to the local computer system 210 for local data processing and manipulation.

[0281] It will be appreciated that the surgical data network 201 may be expanded by interconnecting multiple network hubs 207 and/or multiple network switches 209 with multiple network routers 211. The modular communication hub 203 may be contained in a modular control tower configured to receive multiple devices 1a-1n/2a-2m. The local computer system 210 also may be contained in a modular control tower. The modular communication hub 203 is connected to

a display 212 to display images obtained by some of the devices 1a-1n/2a-2m, for example during surgical procedures. In various aspects, the devices 1a-1n/2a-2m may include, for example, various modules such as an imaging module 138 coupled to an endoscope, a generator module 140 coupled to an energy-based surgical device, a smoke evacuation module 126, a suction/irrigation module 128, a communication module 130, a processor module 132, a storage array 134, a surgical device coupled to a display, and/or a non-contact sensor module, among other modular devices that may be connected to the modular communication hub 203 of the surgical data network 201.

[0282] In one aspect, the surgical data network 201 may comprise a combination of network hub(s), network switch(es), and network router(s) connecting the devices 1a-1n/2a-2m to the cloud. Any one of or all of the devices 1a-1n/2a-2m coupled to the network hub or network switch may collect data in real time and transfer the data to cloud computers for data processing and manipulation. It will be appreciated that cloud computing relies on sharing computing resources rather than having local servers or personal devices to handle software applications. The word “cloud” may be used as a metaphor for “the Internet,” although the term is not limited as such. Accordingly, the term “cloud computing” may be used herein to refer to “a type of Internet-based computing,” where different services—such as servers, storage, and applications—are delivered to the modular communication hub 203 and/or computer system 210 located in the surgical theater (e.g., a fixed, mobile, temporary, or field operating room or space) and to devices connected to the modular communication hub 203 and/or computer system 210 through the Internet. The cloud infrastructure may be maintained by a cloud service provider. In this context, the cloud service provider may be the entity that coordinates the usage and control of the devices 1a-1n/2a-2m located in one or more operating theaters. The cloud computing services can perform a large number of calculations based on the data gathered by smart surgical instruments, robots, and other computerized devices located in the operating theater. The hub hardware enables multiple devices or connections to be connected to a computer that communicates with the cloud computing resources and storage.

[0283] Applying cloud computer data processing techniques on the data collected by the devices 1a-1n/2a-2m, the surgical data network provides improved surgical outcomes, reduced costs, and improved patient satisfaction. At least some of the devices 1a-1n/2a-2m may be employed to view tissue states to assess leaks or perfusion of sealed tissue after a tissue sealing and cutting procedure. At least some of the devices 1a-1n/2a-2m may be employed to identify pathology, such as the effects of diseases, using the cloud-based computing to examine data including images of samples of body tissue for diagnostic purposes. This includes localization and margin confirmation of tissue and phenotypes. At least some of the devices 1a-1n/2a-2m may be employed to identify anatomical structures of the body using a variety of sensors integrated with imaging devices and techniques such as overlaying images captured by multiple imaging devices. The data gathered by the devices 1a-1n/2a-2m, including image data, may be transferred to the cloud 204 or the local computer system 210 or both for data processing and manipulation including image processing and manipulation. The data may be analyzed to improve surgical procedure

outcomes by determining if further treatment, such as the application of endoscopic intervention, emerging technologies, a targeted radiation, targeted intervention, and precise robotics to tissue-specific sites and conditions, may be pursued. Such data analysis may further employ outcome analytics processing, and using standardized approaches may provide beneficial feedback to either confirm surgical treatments and the behavior of the surgeon or suggest modifications to surgical treatments and the behavior of the surgeon.

[0284] In one implementation, the operating theater devices 1a-1n may be connected to the modular communication hub 203 over a wired channel or a wireless channel depending on the configuration of the devices 1a-1n to a network hub. The network hub 207 may be implemented, in one aspect, as a local network broadcast device that works on the physical layer of the Open System Interconnection (OSI) model. The network hub provides connectivity to the devices 1a-1n located in the same operating theater network. The network hub 207 collects data in the form of packets and sends them to the router in half duplex mode. The network hub 207 does not store any media access control/Internet Protocol (MAC/IP) to transfer the device data. Only one of the devices 1a-1n can send data at a time through the network hub 207. The network hub 207 has no routing tables or intelligence regarding where to send information and broadcasts all network data across each connection and to a remote server 213 (FIG. 9) over the cloud 204. The network hub 207 can detect basic network errors such as collisions, but having all information broadcast to multiple ports can be a security risk and cause bottlenecks.

[0285] In another implementation, the operating theater devices 2a-2m may be connected to a network switch 209 over a wired channel or a wireless channel. The network switch 209 works in the data link layer of the OSI model. The network switch 209 is a multicast device for connecting the devices 2a-2m located in the same operating theater to the network. The network switch 209 sends data in the form of frames to the network router 211 and works in full duplex mode. Multiple devices 2a-2m can send data at the same time through the network switch 209. The network switch 209 stores and uses MAC addresses of the devices 2a-2m to transfer data.

[0286] The network hub 207 and/or the network switch 209 are coupled to the network router 211 for connection to the cloud 204. The network router 211 works in the network layer of the OSI model. The network router 211 creates a route for transmitting data packets received from the network hub 207 and/or network switch 211 to cloud-based computer resources for further processing and manipulation of the data collected by any one of or all the devices 1a-1n/2a-2m. The network router 211 may be employed to connect two or more different networks located in different locations, such as, for example, different operating theaters of the same healthcare facility or different networks located in different operating theaters of different healthcare facilities. The network router 211 sends data in the form of packets to the cloud 204 and works in full duplex mode. Multiple devices can send data at the same time. The network router 211 uses IP addresses to transfer data.

[0287] In one example, the network hub 207 may be implemented as a USB hub, which allows multiple USB devices to be connected to a host computer. The USB hub may expand a single USB port into several tiers so that there

are more ports available to connect devices to the host system computer. The network hub 207 may include wired or wireless capabilities to receive information over a wired channel or a wireless channel. In one aspect, a wireless USB short-range, high-bandwidth wireless radio communication protocol may be employed for communication between the devices 1a-1n and devices 2a-2m located in the operating theater.

[0288] In other examples, the operating theater devices 1a-1n/2a-2m may communicate to the modular communication hub 203 via Bluetooth wireless technology standard for exchanging data over short distances (using short-wavelength UHF radio waves in the ISM band from 2.4 to 2.485 GHz) from fixed and mobile devices and building personal area networks (PANs). In other aspects, the operating theater devices 1a-1n/2a-2m may communicate to the modular communication hub 203 via a number of wireless or wired communication standards or protocols, including but not limited to Wi-Fi (IEEE 802.11 family), WMAX (IEEE 802.16 family), IEEE 802.20, long-term evolution (LTE), and Ev-DO, HSPA+, HSDPA+, HSUPA+, EDGE, GSM, GPRS, CDMA, TDMA, DECT, and Ethernet derivatives thereof, as well as any other wireless and wired protocols that are designated as 3G, 4G, 5G, and beyond. The computing module may include a plurality of communication modules. For instance, a first communication module may be dedicated to shorter-range wireless communications such as Wi-Fi and Bluetooth, and a second communication module may be dedicated to longer-range wireless communications such as GPS, EDGE, GPRS, CDMA, WiMAX, LTE, Ev-DO, and others.

[0289] The modular communication hub 203 may serve as a central connection for one or all of the operating theater devices 1a-1n/2a-2m and handles a data type known as frames. Frames carry the data generated by the devices 1a-1n/2a-2m. When a frame is received by the modular communication hub 203, it is amplified and transmitted to the network router 211, which transfers the data to the cloud computing resources by using a number of wireless or wired communication standards or protocols, as described herein.

[0290] The modular communication hub 203 can be used as a standalone device or be connected to compatible network hubs and network switches to form a larger network. The modular communication hub 203 is generally easy to install, configure, and maintain, making it a good option for networking the operating theater devices 1a-1n/2a-2m.

[0291] FIG. 9 illustrates a computer-implemented interactive surgical system 200. The computer-implemented interactive surgical system 200 is similar in many respects to the computer-implemented interactive surgical system 100. For example, the computer-implemented interactive surgical system 200 includes one or more surgical systems 202, which are similar in many respects to the surgical systems 102. Each surgical system 202 includes at least one surgical hub 206 in communication with a cloud 204 that may include a remote server 213. In one aspect, the computer-implemented interactive surgical system 200 comprises a modular control tower 236 connected to multiple operating theater devices such as, for example, intelligent surgical instruments, robots, and other computerized devices located in the operating theater. As shown in FIG. 10, the modular control tower 236 comprises a modular communication hub 203 coupled to a computer system 210. As illustrated in the

example of FIG. 9, the modular control tower 236 is coupled to an imaging module 238 that is coupled to an endoscope 239, a generator module 240 that is coupled to an energy device 241, a smoke evacuator module 226, a suction/irrigation module 228, a communication module 230, a processor module 232, a storage array 234, a smart device/instrument 235 optionally coupled to a display 237, and a non-contact sensor module 242. The operating theater devices are coupled to cloud computing resources and data storage via the modular control tower 236. A robot hub 222 also may be connected to the modular control tower 236 and to the cloud computing resources. The devices/instruments 235, visualization systems 208, among others, may be coupled to the modular control tower 236 via wired or wireless communication standards or protocols, as described herein. The modular control tower 236 may be coupled to a hub display 215 (e.g., monitor, screen) to display and overlay images received from the imaging module, device/instrument display, and/or other visualization systems 208. The hub display also may display data received from devices connected to the modular control tower in conjunction with images and overlaid images.

[0292] FIG. 10 illustrates a surgical hub 206 comprising a plurality of modules coupled to the modular control tower 236. The modular control tower 236 comprises a modular communication hub 203, e.g., a network connectivity device, and a computer system 210 to provide local processing, visualization, and imaging, for example. As shown in FIG. 10, the modular communication hub 203 may be connected in a tiered configuration to expand the number of modules (e.g., devices) that may be connected to the modular communication hub 203 and transfer data associated with the modules to the computer system 210, cloud computing resources, or both. As shown in FIG. 10, each of the network hubs/switches in the modular communication hub 203 includes three downstream ports and one upstream port. The upstream network hub/switch is connected to a processor to provide a communication connection to the cloud computing resources and a local display 217. Communication to the cloud 204 may be made either through a wired or a wireless communication channel.

[0293] The surgical hub 206 employs a non-contact sensor module 242 to measure the dimensions of the operating theater and generate a map of the surgical theater using either ultrasonic or laser-type non-contact measurement devices. An ultrasound-based non-contact sensor module scans the operating theater by transmitting a burst of ultrasound and receiving the echo when it bounces off the perimeter walls of an operating theater as described under the heading "Surgical Hub Spatial Awareness Within an Operating Room" in U.S. Provisional Patent Application Ser. No. 62/611,341, titled INTERACTIVE SURGICAL PLATFORM, filed Dec. 28, 2017, which is herein incorporated by reference in its entirety, in which the sensor module is configured to determine the size of the operating theater and to adjust Bluetooth-pairing distance limits. A laser-based non-contact sensor module scans the operating theater by transmitting laser light pulses, receiving laser light pulses that bounce off the perimeter walls of the operating theater, and comparing the phase of the transmitted pulse to the received pulse to determine the size of the operating theater and to adjust Bluetooth pairing distance limits, for example.

[0294] The computer system 210 comprises a processor 244 and a network interface 245. The processor 244 is

coupled to a communication module 247, storage 248, memory 249, non-volatile memory 250, and input/output interface 251 via a system bus. The system bus can be any of several types of bus structure(s) including the memory bus or memory controller, a peripheral bus or external bus, and/or a local bus using any variety of available bus architectures including, but not limited to, 9-bit bus, Industrial Standard Architecture (ISA), Micro-Charmel Architecture (MSA), Extended ISA (EISA), Intelligent Drive Electronics (IDE), VESA Local Bus (VLB), Peripheral Component Interconnect (PCI), USB, Advanced Graphics Port (AGP), Personal Computer Memory Card International Association bus (PCMCIA), Small Computer Systems Interface (SCSI), or any other proprietary bus.

[0295] The processor 244 may be any single-core or multicore processor such as those known under the trade name ARM Cortex by Texas Instruments. In one aspect, the processor may be an LM4F230H5QR ARM Cortex-M4F Processor Core, available from Texas Instruments, for example, comprising an on-chip memory of 256 KB single-cycle flash memory, or other non-volatile memory, up to 40 MHz, a prefetch buffer to improve performance above 40 MHz, a 32 KB single-cycle serial random access memory (SRAM), an internal read-only memory (ROM) loaded with StellarisWare® software, a 2 KB electrically erasable programmable read-only memory (EEPROM), and/or one or more pulse width modulation (PWM) modules, one or more quadrature encoder inputs (QEI) analogs, one or more 12-bit analog-to-digital converters (ADCs) with 12 analog input channels, details of which are available for the product datasheet.

[0296] In one aspect, the processor 244 may comprise a safety controller comprising two controller-based families such as TMS570 and RM4x, known under the trade name Hercules ARM Cortex R4, also by Texas Instruments. The safety controller may be configured specifically for IEC 61508 and ISO 26262 safety critical applications, among others, to provide advanced integrated safety features while delivering scalable performance, connectivity, and memory options.

[0297] The system memory includes volatile memory and non-volatile memory. The basic input/output system (BIOS), containing the basic routines to transfer information between elements within the computer system, such as during start-up, is stored in non-volatile memory. For example, the non-volatile memory can include ROM, programmable ROM (PROM), electrically programmable ROM (EPROM), EEPROM, or flash memory. Volatile memory includes random-access memory (RAM), which acts as external cache memory. Moreover, RAM is available in many forms such as SRAM, dynamic RAM (DRAM), synchronous DRAM (SDRAM), double data rate SDRAM (DDR SDRAM), enhanced SDRAM (ESDRAM), Synchlink DRAM (SLDRAM), and direct Rambus RAM (DRRAM).

[0298] The computer system 210 also includes removable/non-removable, volatile/non-volatile computer storage media, such as for example disk storage. The disk storage includes, but is not limited to, devices like a magnetic disk drive, floppy disk drive, tape drive, Jaz drive, Zip drive, LS-60 drive, flash memory card, or memory stick. In addition, the disk storage can include storage media separately or in combination with other storage media including, but not limited to, an optical disc drive such as a compact disc ROM device (CD-ROM), compact disc recordable drive (CD-R

Drive), compact disc rewritable drive (CD-RW Drive), or a digital versatile disc ROM drive (DVD-ROM). To facilitate the connection of the disk storage devices to the system bus, a removable or non-removable interface may be employed.

[0299] It is to be appreciated that the computer system 210 includes software that acts as an intermediary between users and the basic computer resources described in a suitable operating environment. Such software includes an operating system. The operating system, which can be stored on the disk storage, acts to control and allocate resources of the computer system. System applications take advantage of the management of resources by the operating system through program modules and program data stored either in the system memory or on the disk storage. It is to be appreciated that various components described herein can be implemented with various operating systems or combinations of operating systems.

[0300] A user enters commands or information into the computer system 210 through input device(s) coupled to the I/O interface 251. The input devices include, but are not limited to, a pointing device such as a mouse, trackball, stylus, touch pad, keyboard, microphone, joystick, game pad, satellite dish, scanner, TV tuner card, digital camera, digital video camera, web camera, and the like. These and other input devices connect to the processor through the system bus via interface port(s). The interface port(s) include, for example, a serial port, a parallel port, a game port, and a USB. The output device(s) use some of the same types of ports as input device(s). Thus, for example, a USB port may be used to provide input to the computer system and to output information from the computer system to an output device. An output adapter is provided to illustrate that there are some output devices like monitors, displays, speakers, and printers, among other output devices that require special adapters. The output adapters include, by way of illustration and not limitation, video and sound cards that provide a means of connection between the output device and the system bus. It should be noted that other devices and/or systems of devices, such as remote computer(s), provide both input and output capabilities.

[0301] The computer system 210 can operate in a networked environment using logical connections to one or more remote computers, such as cloud computer(s), or local computers. The remote cloud computer(s) can be a personal computer, server, router, network PC, workstation, micro-processor-based appliance, peer device, or other common network node, and the like, and typically includes many or all of the elements described relative to the computer system. For purposes of brevity, only a memory storage device is illustrated with the remote computer(s). The remote computer(s) is logically connected to the computer system through a network interface and then physically connected via a communication connection. The network interface encompasses communication networks such as local area networks (LANs) and wide area networks (WANs). LAN technologies include Fiber Distributed Data Interface (FDDI), Copper Distributed Data Interface (CDDI), Ethernet/IEEE 802.3, Token Ring/IEEE 802.5 and the like. WAN technologies include, but are not limited to, point-to-point links, circuit-switching networks like Integrated Services Digital Networks (ISDN) and variations thereon, packet-switching networks, and Digital Subscriber Lines (DSL).

[0302] In various aspects, the computer system 210 of FIG. 10, the imaging module 238 and/or visualization system 208, and/or the processor module 232 of FIGS. 9-10, may comprise an image processor, image-processing engine, media processor, or any specialized digital signal processor (DSP) used for the processing of digital images. The image processor may employ parallel computing with single instruction, multiple data (SIMD) or multiple instruction, multiple data (MIMD) technologies to increase speed and efficiency. The digital image-processing engine can perform a range of tasks. The image processor may be a system on a chip with multicore processor architecture.

[0303] The communication connection(s) refers to the hardware/software employed to connect the network interface to the bus. While the communication connection is shown for illustrative clarity inside the computer system, it can also be external to the computer system 210. The hardware/software necessary for connection to the network interface includes, for illustrative purposes only, internal and external technologies such as modems, including regular telephone-grade modems, cable modems, and DSL modems, ISDN adapters, and Ethernet cards.

[0304] FIG. 11 illustrates a functional block diagram of one aspect of a USB network hub 300 device, in accordance with at least one aspect of the present disclosure. In the illustrated aspect, the USB network hub device 300 employs a TUSB2036 integrated circuit hub by Texas Instruments. The USB network hub 300 is a CMOS device that provides an upstream USB transceiver port 302 and up to three downstream USB transceiver ports 304, 306, 308 in compliance with the USB 2.0 specification. The upstream USB transceiver port 302 is a differential root data port comprising a differential data minus (DM0) input paired with a differential data plus (DPO) input. The three downstream USB transceiver ports 304, 306, 308 are differential data ports where each port includes differential data plus (DP1-DP3) outputs paired with differential data minus (DM1-DM3) outputs.

[0305] The USB network hub 300 device is implemented with a digital state machine instead of a microcontroller, and no firmware programming is required. Fully compliant USB transceivers are integrated into the circuit for the upstream USB transceiver port 302 and all downstream USB transceiver ports 304, 306, 308. The downstream USB transceiver ports 304, 306, 308 support both full-speed and low-speed devices by automatically setting the slew rate according to the speed of the device attached to the ports. The USB network hub 300 device may be configured either in bus-powered or self-powered mode and includes a hub power logic 312 to manage power.

[0306] The USB network hub 300 device includes a serial interface engine 310 (SIE). The SIE 310 is the front end of the USB network hub 300 hardware and handles most of the protocol described in chapter 8 of the USB specification. The SIE 310 typically comprehends signaling up to the transaction level. The functions that it handles could include: packet recognition, transaction sequencing, SOP, EOP, RESET, and RESUME signal detection/generation, clock/data separation, non-return-to-zero invert (NRZI) data encoding/decoding and bit-stuffing, CRC generation and checking (token and data), packet ID (PID) generation and checking/decoding, and/or serial-parallel/parallel-serial conversion. The 310 receives a clock input 314 and is coupled to a suspend/resume logic and frame timer 316 circuit and a

hub repeater circuit 318 to control communication between the upstream USB transceiver port 302 and the downstream USB transceiver ports 304, 306, 308 through port logic circuits 320, 322, 324. The SIE 310 is coupled to a command decoder 326 via interface logic to control commands from a serial EEPROM via a serial EEPROM interface 330.

[0307] In various aspects, the USB network hub 300 can connect 127 functions configured in up to six logical layers (tiers) to a single computer. Further, the USB network hub 300 can connect to all peripherals using a standardized four-wire cable that provides both communication and power distribution. The power configurations are bus-powered and self-powered modes. The USB network hub 300 may be configured to support four modes of power management: a bus-powered hub, with either individual-port power management or ganged-port power management, and the self-powered hub, with either individual-port power management or ganged-port power management. In one aspect, using a USB cable, the USB network hub 300, the upstream USB transceiver port 302 is plugged into a USB host controller, and the downstream USB transceiver ports 304, 306, 308 are exposed for connecting USB compatible devices, and so forth.

Surgical Instrument Hardware

[0308] FIG. 12 illustrates a logic diagram of a control system 470 of a surgical instrument or tool in accordance with one or more aspects of the present disclosure. The system 470 comprises a control circuit. The control circuit includes a microcontroller 461 comprising a processor 462 and a memory 468. One or more of sensors 472, 474, 476, for example, provide real-time feedback to the processor 462. A motor 482, driven by a motor driver 492, operably couples a longitudinally movable displacement member to drive a clamp arm closure member. A tracking system 480 is configured to determine the position of the longitudinally movable displacement member. The position information is provided to the processor 462, which can be programmed or configured to determine the position of the longitudinally movable drive member as well as the position of the closure member. Additional motors may be provided at the tool driver interface to control closure tube travel, shaft rotation, articulation, or clamp arm closure, or a combination of the above. A display 473 displays a variety of operating conditions of the instruments and may include touch screen functionality for data input. Information displayed on the display 473 may be overlaid with images acquired via endoscopic imaging modules.

[0309] In one aspect, the microcontroller 461 may be any single-core or multicore processor such as those known under the trade name ARM Cortex by Texas Instruments. In one aspect, the main microcontroller 461 may be an LM4F230H5QR ARM Cortex-M4F Processor Core, available from Texas Instruments, for example, comprising an on-chip memory of 256 KB single-cycle flash memory, or other non-volatile memory, up to 40 MHz, a prefetch buffer to improve performance above 40 MHz, a 32 KB single-cycle SRAM, and internal ROM loaded with StellarisWare® software, a 2 KB EEPROM, one or more PWM modules, one or more QE1 analogs, and/or one or more 12-bit ADCs with 12 analog input channels, details of which are available for the product datasheet.

[0310] In one aspect, the microcontroller 461 may comprise a safety controller comprising two controller-based

families such as TMS570 and RM4x, known under the trade name Hercules ARM Cortex R4, also by Texas Instruments. The safety controller may be configured specifically for IEC 61508 and ISO 26262 safety critical applications, among others, to provide advanced integrated safety features while delivering scalable performance, connectivity, and memory options.

[0311] The microcontroller 461 may be programmed to perform various functions such as precise control over the speed and position of the knife, articulation systems, clamp arm, or a combination of the above. In one aspect, the microcontroller 461 includes a processor 462 and a memory 468. The electric motor 482 may be a brushed direct current (DC) motor with a gearbox and mechanical links to an articulation or knife system. In one aspect, a motor driver 492 may be an A3941 available from Allegro Microsystems, Inc. Other motor drivers may be readily substituted for use in the tracking system 480 comprising an absolute positioning system. A detailed description of an absolute positioning system is described in U.S. Patent Application Publication No. 2017/0296213, titled SYSTEMS AND METHODS FOR CONTROLLING A SURGICAL STAPLING AND CUTTING INSTRUMENT, which published on Oct. 19, 2017, which is herein incorporated by reference in its entirety.

[0312] The microcontroller 461 may be programmed to provide precise control over the speed and position of displacement members and articulation systems. The microcontroller 461 may be configured to compute a response in the software of the microcontroller 461. The computed response is compared to a measured response of the actual system to obtain an "observed" response, which is used for actual feedback decisions. The observed response is a favorable, tuned value that balances the smooth, continuous nature of the simulated response with the measured response, which can detect outside influences on the system.

[0313] In one aspect, the motor 482 may be controlled by the motor driver 492 and can be employed by the firing system of the surgical instrument or tool. In various forms, the motor 482 may be a brushed DC driving motor having a maximum rotational speed of approximately 25,000 RPM. In other arrangements, the motor 482 may include a brushless motor, a cordless motor, a synchronous motor, a stepper motor, or any other suitable electric motor. The motor driver 492 may comprise an H-bridge driver comprising field-effect transistors (FETs), for example. The motor 482 can be powered by a power assembly releasably mounted to the handle assembly or tool housing for supplying control power to the surgical instrument or tool. The power assembly may comprise a battery which may include a number of battery cells connected in series that can be used as the power source to power the surgical instrument or tool. In certain circumstances, the battery cells of the power assembly may be replaceable and/or rechargeable battery cells. In at least one example, the battery cells can be lithium-ion batteries which can be coupleable to and separable from the power assembly.

[0314] The motor driver 492 may be an A3941 available from Allegro Microsystems, Inc. The A3941 492 is a full-bridge controller for use with external N-channel power metal-oxide semiconductor field-effect transistors (MOSFETs) specifically designed for inductive loads, such as brush DC motors. The driver 492 comprises a unique charge pump regulator that provides full (>10 V) gate drive for battery voltages down to 7 V and allows the A3941 to

operate with a reduced gate drive, down to 5.5 V. A bootstrap capacitor may be employed to provide the above battery supply voltage required for N-channel MOSFETs. An internal charge pump for the high-side drive allows DC (100% duty cycle) operation. The full bridge can be driven in fast or slow decay modes using diode or synchronous rectification. In the slow decay mode, current recirculation can be through the high-side or the low-side FETs. The power FETs are protected from shoot-through by resistor-adjustable dead time. Integrated diagnostics provide indications of under-voltage, overtemperature, and power bridge faults and can be configured to protect the power MOSFETs under most short circuit conditions. Other motor drivers may be readily substituted for use in the tracking system 480 comprising an absolute positioning system.

[0315] The tracking system 480 comprises a controlled motor drive circuit arrangement comprising a position sensor 472 according to one aspect of this disclosure. The position sensor 472 for an absolute positioning system provides a unique position signal corresponding to the location of a displacement member. In one aspect, the displacement member represents a longitudinally movable drive member comprising a rack of drive teeth for meshing engagement with a corresponding drive gear of a gear reducer assembly. In other aspects, the displacement member represents the firing member, which could be adapted and configured to include a rack of drive teeth. In yet another aspect, the displacement member represents a longitudinal displacement member to open and close a clamp arm, which can be adapted and configured to include a rack of drive teeth. In other aspects, the displacement member represents a clamp arm closure member configured to close and to open a clamp arm of a stapler, ultrasonic, or electrosurgical device, or combinations of the above. Accordingly, as used herein, the term displacement member is used generically to refer to any movable member of the surgical instrument or tool such as the drive member, the clamp arm, or any element that can be displaced. Accordingly, the absolute positioning system can, in effect, track the displacement of the clamp arm by tracking the linear displacement of the longitudinally movable drive member.

[0316] In other aspects, the absolute positioning system can be configured to track the position of a clamp arm in the process of closing or opening. In various other aspects, the displacement member may be coupled to any position sensor 472 suitable for measuring linear displacement. Thus, the longitudinally movable drive member, or clamp arm, or combinations thereof, may be coupled to any suitable linear displacement sensor. Linear displacement sensors may include contact or non-contact displacement sensors. Linear displacement sensors may comprise linear variable differential transformers (LVDT), differential variable reluctance transducers (DVRT), a slide potentiometer, a magnetic sensing system comprising a movable magnet and a series of linearly arranged Hall effect sensors, a magnetic sensing system comprising a fixed magnet and a series of movable, linearly arranged Hall effect sensors, an optical sensing system comprising a movable light source and a series of linearly arranged photo diodes or photo detectors, an optical sensing system comprising a fixed light source and a series of movable linearly, arranged photo diodes or photo detectors, or any combination thereof.

[0317] The electric motor 482 can include a rotatable shaft that operably interfaces with a gear assembly that is

mounted in meshing engagement with a set, or rack, of drive teeth on the displacement member. A sensor element may be operably coupled to a gear assembly such that a single revolution of the position sensor 472 element corresponds to some linear longitudinal translation of the displacement member. An arrangement of gearing and sensors can be connected to the linear actuator, via a rack and pinion arrangement, or a rotary actuator, via a spur gear or other connection. A power source supplies power to the absolute positioning system and an output indicator may display the output of the absolute positioning system. The displacement member represents the longitudinally movable drive member comprising a rack of drive teeth formed thereon for meshing engagement with a corresponding drive gear of the gear reducer assembly. The displacement member represents the longitudinally movable firing member to open and close a clamp arm.

[0318] A single revolution of the sensor element associated with the position sensor 472 is equivalent to a longitudinal linear displacement d_1 of the of the displacement member, where d_1 is the longitudinal linear distance that the displacement member moves from point “a” to point “b” after a single revolution of the sensor element coupled to the displacement member. The sensor arrangement may be connected via a gear reduction that results in the position sensor 472 completing one or more revolutions for the full stroke of the displacement member. The position sensor 472 may complete multiple revolutions for the full stroke of the displacement member.

[0319] A series of switches, where n is an integer greater than one, may be employed alone or in combination with a gear reduction to provide a unique position signal for more than one revolution of the position sensor 472. The state of the switches are fed back to the microcontroller 461 that applies logic to determine a unique position signal corresponding to the longitudinal linear displacement $d_1+d_2+d_3$ of the displacement member. The output of the position sensor 472 is provided to the microcontroller 461. The position sensor 472 of the sensor arrangement may comprise a magnetic sensor, an analog rotary sensor like a potentiometer, or an array of analog Hall-effect elements, which output a unique combination of position signals or values.

[0320] The position sensor 472 may comprise any number of magnetic sensing elements, such as, for example, magnetic sensors classified according to whether they measure the total magnetic field or the vector components of the magnetic field. The techniques used to produce both types of magnetic sensors encompass many aspects of physics and electronics. The technologies used for magnetic field sensing include search coil, fluxgate, optically pumped, nuclear precession, SQUID, Hall-effect, anisotropic magnetoresistance, giant magnetoresistance, magnetic tunnel junctions, giant magnetoimpedance, magnetostrictive/piezoelectric composites, magnetodiode, magnetotransistor, fiber-optic, magneto-optic, and microelectromechanical systems-based magnetic sensors, among others.

[0321] In one aspect, the position sensor 472 for the tracking system 480 comprising an absolute positioning system comprises a magnetic rotary absolute positioning system. The position sensor 472 may be implemented as an AS5055EQFT single-chip magnetic rotary position sensor available from Austria Microsystems, AG. The position sensor 472 is interfaced with the microcontroller 461 to provide an absolute positioning system. The position sensor

472 is a low-voltage and low-power component and includes four Hall-effect elements in an area of the position sensor 472 that is located above a magnet. A high-resolution ADC and a smart power management controller are also provided on the chip. A coordinate rotation digital computer (CORDIC) processor, also known as the digit-by-digit method and Volder’s algorithm, is provided to implement a simple and efficient algorithm to calculate hyperbolic and trigonometric functions that require only addition, subtraction, bitshift, and table lookup operations. The angle position, alarm bits, and magnetic field information are transmitted over a standard serial communication interface, such as a serial peripheral interface (SPI) interface, to the microcontroller 461. The position sensor 472 provides 12 or 14 bits of resolution. The position sensor 472 may be an AS5055 chip provided in a small QFN 16-pin $4 \times 4 \times 0.85$ mm package.

[0322] The tracking system 480 comprising an absolute positioning system may comprise and/or be programmed to implement a feedback controller, such as a PID, state feedback, and adaptive controller. A power source converts the signal from the feedback controller into a physical input to the system: in this case the voltage. Other examples include a PWM of the voltage, current, and force. Other sensor(s) may be provided to measure physical parameters of the physical system in addition to the position measured by the position sensor 472. In some aspects, the other sensor(s) can include sensor arrangements such as those described in U.S. Pat. No. 9,345,481, titled STAPLE CARTRIDGE TISSUE THICKNESS SENSOR SYSTEM, which issued on May 24, 2016, which is herein incorporated by reference in its entirety; U.S. Patent Application Publication No. 2014/0263552, titled STAPLE CARTRIDGE TISSUE THICKNESS SENSOR SYSTEM, which published on Sep. 18, 2014, which is herein incorporated by reference in its entirety; and U.S. patent application Ser. No. 15/628,175, titled TECHNIQUES FOR ADAPTIVE CONTROL OF MOTOR VELOCITY OF A SURGICAL STAPLING AND CUTTING INSTRUMENT, filed Jun. 20, 2017, which is herein incorporated by reference in its entirety. In a digital signal processing system, an absolute positioning system is coupled to a digital data acquisition system where the output of the absolute positioning system will have a finite resolution and sampling frequency. The absolute positioning system may comprise a compare-and-combine circuit to combine a computed response with a measured response using algorithms, such as a weighted average and a theoretical control loop, that drive the computed response towards the measured response. The computed response of the physical system takes into account properties like mass, inertia, viscous friction, inductance resistance, etc., to predict what the states and outputs of the physical system will be by knowing the input.

[0323] The absolute positioning system provides an absolute position of the displacement member upon power-up of the instrument, without retracting or advancing the displacement member to a reset (zero or home) position as may be required with conventional rotary encoders that merely count the number of steps forwards or backwards that the motor 482 has taken to infer the position of a device actuator, drive bar, knife, or the like.

[0324] A sensor 474, such as, for example, a strain gauge or a micro-strain gauge, is configured to measure one or more parameters of the end effector, such as, for example,

the amplitude of the strain exerted on the anvil during a clamping operation, which can be indicative of the closure forces applied to the anvil. The measured strain is converted to a digital signal and provided to the processor 462. Alternatively, or in addition to the sensor 474, a sensor 476, such as, for example, a load sensor, can measure the closure force applied by the closure drive system to the anvil in a stapler or a clamp arm in an ultrasonic or electrosurgical instrument. The sensor 476, such as, for example, a load sensor, can measure the firing force applied to a closure member coupled to a clamp arm of the surgical instrument or tool or the force applied by a clamp arm to tissue located in the jaws of an ultrasonic or electrosurgical instrument. Alternatively, a current sensor 478 can be employed to measure the current drawn by the motor 482. The displacement member also may be configured to engage a clamp arm to open or close the clamp arm. The force sensor may be configured to measure the clamping force on tissue. The force required to advance the displacement member can correspond to the current drawn by the motor 482, for example. The measured force is converted to a digital signal and provided to the processor 462.

[0325] In one form, the strain gauge sensor 474 can be used to measure the force applied to the tissue by the end effector. A strain gauge can be coupled to the end effector to measure the force on the tissue being treated by the end effector. A system for measuring forces applied to the tissue grasped by the end effector comprises a strain gauge sensor 474, such as, for example, a micro-strain gauge, that is configured to measure one or more parameters of the end effector, for example. In one aspect, the strain gauge sensor 474 can measure the amplitude or magnitude of the strain exerted on a jaw member of an end effector during a clamping operation, which can be indicative of the tissue compression. The measured strain is converted to a digital signal and provided to a processor 462 of the microcontroller 461. A load sensor 476 can measure the force used to operate the knife element, for example, to cut the tissue captured between the anvil and the staple cartridge. A load sensor 476 can measure the force used to operate the clamp arm element, for example, to capture tissue between the clamp arm and an ultrasonic blade or to capture tissue between the clamp arm and a jaw of an electrosurgical instrument. A magnetic field sensor can be employed to measure the thickness of the captured tissue. The measurement of the magnetic field sensor also may be converted to a digital signal and provided to the processor 462.

[0326] The measurements of the tissue compression, the tissue thickness, and/or the force required to close the end effector on the tissue, as respectively measured by the sensors 474, 476, can be used by the microcontroller 461 to characterize the selected position of the firing member and/or the corresponding value of the speed of the firing member. In one instance, a memory 468 may store a technique, an equation, and/or a lookup table which can be employed by the microcontroller 461 in the assessment.

[0327] The control system 470 of the surgical instrument or tool also may comprise wired or wireless communication circuits to communicate with the modular communication hub as shown in FIGS. 8-11.

[0328] FIG. 13 illustrates a control circuit 500 configured to control aspects of the surgical instrument or tool according to one aspect of this disclosure. The control circuit 500 can be configured to implement various processes described

herein. The control circuit 500 may comprise a microcontroller comprising one or more processors 502 (e.g., microprocessor, microcontroller) coupled to at least one memory circuit 504. The memory circuit 504 stores machine-executable instructions that, when executed by the processor 502, cause the processor 502 to execute machine instructions to implement various processes described herein. The processor 502 may be any one of a number of single-core or multicore processors known in the art. The memory circuit 504 may comprise volatile and non-volatile storage media. The processor 502 may include an instruction processing unit 506 and an arithmetic unit 508. The instruction processing unit may be configured to receive instructions from the memory circuit 504 of this disclosure.

[0329] FIG. 14 illustrates a combinational logic circuit 510 configured to control aspects of the surgical instrument or tool according to one aspect of this disclosure. The combinational logic circuit 510 can be configured to implement various processes described herein. The combinational logic circuit 510 may comprise a finite state machine comprising a combinational logic 512 configured to receive data associated with the surgical instrument or tool at an input 514, process the data by the combinational logic 512, and provide an output 516.

[0330] FIG. 15 illustrates a sequential logic circuit 520 configured to control aspects of the surgical instrument or tool according to one aspect of this disclosure. The sequential logic circuit 520 or the combinational logic 522 can be configured to implement various processes described herein. The sequential logic circuit 520 may comprise a finite state machine. The sequential logic circuit 520 may comprise a combinational logic 522, at least one memory circuit 524, and a clock 529, for example. The at least one memory circuit 524 can store a current state of the finite state machine. In certain instances, the sequential logic circuit 520 may be synchronous or asynchronous. The combinational logic 522 is configured to receive data associated with the surgical instrument or tool from an input 526, process the data by the combinational logic 522, and provide an output 528. In other aspects, the circuit may comprise a combination of a processor (e.g., processor 502, FIG. 13) and a finite state machine to implement various processes herein. In other aspects, the finite state machine may comprise a combination of a combinational logic circuit (e.g., combinational logic circuit 510, FIG. 14) and the sequential logic circuit 520.

[0331] FIG. 16 illustrates a surgical instrument or tool comprising a plurality of motors which can be activated to perform various functions. In certain instances, a first motor can be activated to perform a first function, a second motor can be activated to perform a second function, a third motor can be activated to perform a third function, a fourth motor can be activated to perform a fourth function, and so on. In certain instances, the plurality of motors of robotic surgical instrument 600 can be individually activated to cause firing, closure, and/or articulation motions in the end effector. The firing, closure, and/or articulation motions can be transmitted to the end effector through a shaft assembly, for example.

[0332] In certain instances, the surgical instrument system or tool may include a firing motor 602. The firing motor 602 may be operably coupled to a firing motor drive assembly 604 which can be configured to transmit firing motions, generated by the motor 602 to the end effector, in particular to displace the clamp arm closure member. The closure

member may be retracted by reversing the direction of the motor **602**, which also causes the clamp arm to open.

[0333] In certain instances, the surgical instrument or tool may include a closure motor **603**. The closure motor **603** may be operably coupled to a closure motor drive assembly **605** which can be configured to transmit closure motions, generated by the motor **603** to the end effector, in particular to displace a closure tube to close the anvil and compress tissue between the anvil and the staple cartridge. The closure motor **603** may be operably coupled to a closure motor drive assembly **605** which can be configured to transmit closure motions, generated by the motor **603** to the end effector, in particular to displace a closure tube to close the clamp arm and compress tissue between the clamp arm and either an ultrasonic blade or jaw member of an electrosurgical device. The closure motions may cause the end effector to transition from an open configuration to an approximated configuration to capture tissue, for example. The end effector may be transitioned to an open position by reversing the direction of the motor **603**.

[0334] In certain instances, the surgical instrument or tool may include one or more articulation motors **606a**, **606b**, for example. The motors **606a**, **606b** may be operably coupled to respective articulation motor drive assemblies **608a**, **608b**, which can be configured to transmit articulation motions generated by the motors **606a**, **606b** to the end effector. In certain instances, the articulation motions may cause the end effector to articulate relative to the shaft, for example.

[0335] As described above, the surgical instrument or tool may include a plurality of motors which may be configured to perform various independent functions. In certain instances, the plurality of motors of the surgical instrument or tool can be individually or separately activated to perform one or more functions while the other motors remain inactive. For example, the articulation motors **606a**, **606b** can be activated to cause the end effector to be articulated while the firing motor **602** remains inactive. Alternatively, the firing motor **602** can be activated to fire the plurality of staples, and/or to advance the cutting edge, while the articulation motor **606** remains inactive. Furthermore, the closure motor **603** may be activated simultaneously with the firing motor **602** to cause the closure tube or closure member to advance distally as described in more detail hereinbelow.

[0336] In certain instances, the surgical instrument or tool may include a common control module **610** which can be employed with a plurality of motors of the surgical instrument or tool. In certain instances, the common control module **610** may accommodate one of the plurality of motors at a time. For example, the common control module **610** can be coupleable to and separable from the plurality of motors of the robotic surgical instrument individually. In certain instances, a plurality of the motors of the surgical instrument or tool may share one or more common control modules such as the common control module **610**. In certain instances, a plurality of motors of the surgical instrument or tool can be individually and selectively engaged with the common control module **610**. In certain instances, the common control module **610** can be selectively switched from interfacing with one of a plurality of motors of the surgical instrument or tool to interfacing with another one of the plurality of motors of the surgical instrument or tool.

[0337] In at least one example, the common control module **610** can be selectively switched between operable

engagement with the articulation motors **606a**, **606b** and operable engagement with either the firing motor **602** or the closure motor **603**. In at least one example, as illustrated in FIG. 16, a switch **614** can be moved or transitioned between a plurality of positions and/or states. In a first position **616**, the switch **614** may electrically couple the common control module **610** to the firing motor **602**; in a second position **617**, the switch **614** may electrically couple the common control module **610** to the closure motor **603**; in a third position **618a**, the switch **614** may electrically couple the common control module **610** to the first articulation motor **606a**; and in a fourth position **618b**, the switch **614** may electrically couple the common control module **610** to the second articulation motor **606b**, for example. In certain instances, separate common control modules **610** can be electrically coupled to the firing motor **602**, the closure motor **603**, and the articulations motor **606a**, **606b** at the same time. In certain instances, the switch **614** may be a mechanical switch, an electromechanical switch, a solid-state switch, or any suitable switching mechanism.

[0338] Each of the motors **602**, **603**, **606a**, **606b** may comprise a torque sensor to measure the output torque on the shaft of the motor. The force on an end effector may be sensed in any conventional manner, such as by force sensors on the outer sides of the jaws or by a torque sensor for the motor actuating the jaws.

[0339] In various instances, as illustrated in FIG. 16, the common control module **610** may comprise a motor driver **626** which may comprise one or more H-Bridge FETs. The motor driver **626** may modulate the power transmitted from a power source **628** to a motor coupled to the common control module **610** based on input from a microcontroller **620** (the “controller”), for example. In certain instances, the microcontroller **620** can be employed to determine the current drawn by the motor, for example, while the motor is coupled to the common control module **610**, as described above.

[0340] In certain instances, the microcontroller **620** may include a microprocessor **622** (the “processor”) and one or more non-transitory computer-readable mediums or memory units **624** (the “memory”). In certain instances, the memory **624** may store various program instructions, which when executed may cause the processor **622** to perform a plurality of functions and/or calculations described herein. In certain instances, one or more of the memory units **624** may be coupled to the processor **622**, for example. In various aspects, the microcontroller **620** may communicate over a wired or wireless channel, or combinations thereof.

[0341] In certain instances, the power source **628** can be employed to supply power to the microcontroller **620**, for example. In certain instances, the power source **628** may comprise a battery (or “battery pack” or “power pack”), such as a lithium-ion battery, for example. In certain instances, the battery pack may be configured to be releasably mounted to a handle for supplying power to the surgical instrument **600**. A number of battery cells connected in series may be used as the power source **628**. In certain instances, the power source **628** may be replaceable and/or rechargeable, for example.

[0342] In various instances, the processor **622** may control the motor driver **626** to control the position, direction of rotation, and/or velocity of a motor that is coupled to the common control module **610**. In certain instances, the processor **622** can signal the motor driver **626** to stop and/or

disable a motor that is coupled to the common control module 610. It should be understood that the term “processor” as used herein includes any suitable microprocessor, microcontroller, or other basic computing device that incorporates the functions of a computer’s central processing unit (CPU) on an integrated circuit or, at most, a few integrated circuits. The processor 622 is a multipurpose, programmable device that accepts digital data as input, processes it according to instructions stored in its memory, and provides results as output. It is an example of sequential digital logic, as it has internal memory. Processors operate on numbers and symbols represented in the binary numeral system.

[0343] In one instance, the processor 622 may be any single-core or multicore processor such as those known under the trade name ARM Cortex by Texas Instruments. In certain instances, the microcontroller 620 may be an LM4F230H5QR, available from Texas Instruments, for example. In at least one example, the Texas Instruments LM4F230H5QR is an ARM Cortex-M4F Processor Core comprising an on-chip memory of 256 KB single-cycle flash memory, or other non-volatile memory, up to 40 MHz, a prefetch buffer to improve performance above 40 MHz, a 32 KB single-cycle SRAM, an internal ROM loaded with StellarisWare® software, a 2 KB EEPROM, one or more PWM modules, one or more QEI analogs, one or more 12-bit ADCs with 12 analog input channels, among other features that are readily available for the product datasheet. Other microcontrollers may be readily substituted for use with the module 4410. Accordingly, the present disclosure should not be limited in this context.

[0344] In certain instances, the memory 624 may include program instructions for controlling each of the motors of the surgical instrument 600 that are couplable to the common control module 610. For example, the memory 624 may include program instructions for controlling the firing motor 602, the closure motor 603, and the articulation motors 606a, 606b. Such program instructions may cause the processor 622 to control the firing, closure, and articulation functions in accordance with inputs from algorithms or control programs of the surgical instrument or tool.

[0345] In certain instances, one or more mechanisms and/or sensors such as, for example, sensors 630 can be employed to alert the processor 622 to the program instructions that should be used in a particular setting. For example, the sensors 630 may alert the processor 622 to use the program instructions associated with firing, closing, and articulating the end effector. In certain instances, the sensors 630 may comprise position sensors which can be employed to sense the position of the switch 614, for example. Accordingly, the processor 622 may use the program instructions associated with firing the closure member coupled to the clamp arm of the end effector upon detecting, through the sensors 630 for example, that the switch 614 is in the first position 616; the processor 622 may use the program instructions associated with closing the anvil upon detecting, through the sensors 630 for example, that the switch 614 is in the second position 617; and the processor 622 may use the program instructions associated with articulating the end effector upon detecting, through the sensors 630 for example, that the switch 614 is in the third or fourth position 618a, 618b.

[0346] FIG. 17 is a schematic diagram of a robotic surgical instrument 700 configured to operate a surgical tool described herein according to one aspect of this disclosure.

The robotic surgical instrument 700 may be programmed or configured to control distal/proximal translation of a displacement member, distal/proximal displacement of a closure tube, shaft rotation, and articulation, either with single or multiple articulation drive links. In one aspect, the surgical instrument 700 may be programmed or configured to individually control a firing member, a closure member, a shaft member, or one or more articulation members, or combinations thereof. The surgical instrument 700 comprises a control circuit 710 configured to control motor-driven firing members, closure members, shaft members, or one or more articulation members, or combinations thereof.

[0347] In one aspect, the robotic surgical instrument 700 comprises a control circuit 710 configured to control a clamp arm 716 and a closure member 714 portion of an end effector 702, an ultrasonic blade 718 coupled to an ultrasonic transducer 719 excited by an ultrasonic generator 721, a shaft 740, and one or more articulation members 742a, 742b via a plurality of motors 704a-704e. A position sensor 734 may be configured to provide position feedback of the closure member 714 to the control circuit 710. Other sensors 738 may be configured to provide feedback to the control circuit 710. A timer/counter 731 provides timing and counting information to the control circuit 710. An energy source 712 may be provided to operate the motors 704a-704e, and a current sensor 736 provides motor current feedback to the control circuit 710. The motors 704a-704e can be operated individually by the control circuit 710 in an open-loop or closed-loop feedback control.

[0348] In one aspect, the control circuit 710 may comprise one or more microcontrollers, microprocessors, or other suitable processors for executing instructions that cause the processor or processors to perform one or more tasks. In one aspect, a timer/counter 731 provides an output signal, such as the elapsed time or a digital count, to the control circuit 710 to correlate the position of the closure member 714 as determined by the position sensor 734 with the output of the timer/counter 731 such that the control circuit 710 can determine the position of the closure member 714 at a specific time (t) relative to a starting position or the time (t) when the closure member 714 is at a specific position relative to a starting position. The timer/counter 731 may be configured to measure elapsed time, count external events, or time external events.

[0349] In one aspect, the control circuit 710 may be programmed to control functions of the end effector 702 based on one or more tissue conditions. The control circuit 710 may be programmed to sense tissue conditions, such as thickness, either directly or indirectly, as described herein. The control circuit 710 may be programmed to select a firing control program or closure control program based on tissue conditions. A firing control program may describe the distal motion of the displacement member. Different firing control programs may be selected to better treat different tissue conditions. For example, when thicker tissue is present, the control circuit 710 may be programmed to translate the displacement member at a lower velocity and/or with lower power. When thinner tissue is present, the control circuit 710 may be programmed to translate the displacement member at a higher velocity and/or with higher power. A closure control program may control the closure force applied to the tissue by the clamp arm 716. Other control programs control the rotation of the shaft 740 and the articulation members 742a, 742b.

[0350] In one aspect, the control circuit 710 may generate motor set point signals. The motor set point signals may be provided to various motor controllers 708a-708e. The motor controllers 708a-708e may comprise one or more circuits configured to provide motor drive signals to the motors 704a-704e to drive the motors 704a-704e as described herein. In some examples, the motors 704a-704e may be brushed DC electric motors. For example, the velocity of the motors 704a-704e may be proportional to the respective motor drive signals. In some examples, the motors 704a-704e may be brushless DC electric motors, and the respective motor drive signals may comprise a PWM signal provided to one or more stator windings of the motors 704a-704e. Also, in some examples, the motor controllers 708a-708e may be omitted and the control circuit 710 may generate the motor drive signals directly.

[0351] In one aspect, the control circuit 710 may initially operate each of the motors 704a-704e in an open-loop configuration for a first open-loop portion of a stroke of the displacement member. Based on the response of the robotic surgical instrument 700 during the open-loop portion of the stroke, the control circuit 710 may select a firing control program in a closed-loop configuration. The response of the instrument may include a translation distance of the displacement member during the open-loop portion, a time elapsed during the open-loop portion, the energy provided to one of the motors 704a-704e during the open-loop portion, a sum of pulse widths of a motor drive signal, etc. After the open-loop portion, the control circuit 710 may implement the selected firing control program for a second portion of the displacement member stroke. For example, during a closed-loop portion of the stroke, the control circuit 710 may modulate one of the motors 704a-704e based on translation data describing a position of the displacement member in a closed-loop manner to translate the displacement member at a constant velocity.

[0352] In one aspect, the motors 704a-704e may receive power from an energy source 712. The energy source 712 may be a DC power supply driven by a main alternating current power source, a battery, a super capacitor, or any other suitable energy source. The motors 704a-704e may be mechanically coupled to individual movable mechanical elements such as the closure member 714, clamp arm 716, shaft 740, articulation 742a, and articulation 742b via respective transmissions 706a-706e. The transmissions 706a-706e may include one or more gears or other linkage components to couple the motors 704a-704e to movable mechanical elements. A position sensor 734 may sense a position of the closure member 714. The position sensor 734 may be or include any type of sensor that is capable of generating position data that indicate a position of the closure member 714. In some examples, the position sensor 734 may include an encoder configured to provide a series of pulses to the control circuit 710 as the closure member 714 translates distally and proximally. The control circuit 710 may track the pulses to determine the position of the closure member 714. Other suitable position sensors may be used, including, for example, a proximity sensor. Other types of position sensors may provide other signals indicating motion of the closure member 714. Also, in some examples, the position sensor 734 may be omitted. Where any of the motors 704a-704e is a stepper motor, the control circuit 710 may track the position of the closure member 714 by aggregating the number and direction of steps that the

motor 704 has been instructed to execute. The position sensor 734 may be located in the end effector 702 or at any other portion of the instrument. The outputs of each of the motors 704a-704e include a torque sensor 744a-744e to sense force and have an encoder to sense rotation of the drive shaft.

[0353] In one aspect, the control circuit 710 is configured to drive a firing member such as the closure member 714 portion of the end effector 702. The control circuit 710 provides a motor set point to a motor control 708a, which provides a drive signal to the motor 704a. The output shaft of the motor 704a is coupled to a torque sensor 744a. The torque sensor 744a is coupled to a transmission 706a which is coupled to the closure member 714. The transmission 706a comprises movable mechanical elements such as rotating elements and a firing member to control the movement of the closure member 714 distally and proximally along a longitudinal axis of the end effector 702. In one aspect, the motor 704a may be coupled to the knife gear assembly, which includes a knife gear reduction set that includes a first knife drive gear and a second knife drive gear. A torque sensor 744a provides a firing force feedback signal to the control circuit 710. The firing force signal represents the force required to fire or displace the closure member 714. A position sensor 734 may be configured to provide the position of the closure member 714 along the firing stroke or the position of the firing member as a feedback signal to the control circuit 710. The end effector 702 may include additional sensors 738 configured to provide feedback signals to the control circuit 710. When ready to use, the control circuit 710 may provide a firing signal to the motor control 708a. In response to the firing signal, the motor 704a may drive the firing member distally along the longitudinal axis of the end effector 702 from a proximal stroke start position to a stroke end position distal to the stroke start position. As the closure member 714 translates distally, the clamp arm 716 closes towards the ultrasonic blade 718.

[0354] In one aspect, the control circuit 710 is configured to drive a closure member such as the clamp arm 716 portion of the end effector 702. The control circuit 710 provides a motor set point to a motor control 708b, which provides a drive signal to the motor 704b. The output shaft of the motor 704b is coupled to a torque sensor 744b. The torque sensor 744b is coupled to a transmission 706b which is coupled to the clamp arm 716. The transmission 706b comprises movable mechanical elements such as rotating elements and a closure member to control the movement of the clamp arm 716 from the open and closed positions. In one aspect, the motor 704b is coupled to a closure gear assembly, which includes a closure reduction gear set that is supported in meshing engagement with the closure spur gear. The torque sensor 744b provides a closure force feedback signal to the control circuit 710. The closure force feedback signal represents the closure force applied to the clamp arm 716. The position sensor 734 may be configured to provide the position of the closure member as a feedback signal to the control circuit 710. Additional sensors 738 in the end effector 702 may provide the closure force feedback signal to the control circuit 710. The pivotable clamp arm 716 is positioned opposite the ultrasonic blade 718. When ready to use, the control circuit 710 may provide a closure signal to the motor control 708b. In response to the closure signal, the motor 704b advances a closure member to grasp tissue between the clamp arm 716 and the ultrasonic blade 718.

[0355] In one aspect, the control circuit 710 is configured to rotate a shaft member such as the shaft 740 to rotate the end effector 702. The control circuit 710 provides a motor set point to a motor control 708c, which provides a drive signal to the motor 704c. The output shaft of the motor 704c is coupled to a torque sensor 744c. The torque sensor 744c is coupled to a transmission 706c which is coupled to the shaft 740. The transmission 706c comprises movable mechanical elements such as rotating elements to control the rotation of the shaft 740 clockwise or counterclockwise up to and over 360°. In one aspect, the motor 704c is coupled to the rotational transmission assembly, which includes a tube gear segment that is formed on (or attached to) the proximal end of the proximal closure tube for operable engagement by a rotational gear assembly that is operably supported on the tool mounting plate. The torque sensor 744c provides a rotation force feedback signal to the control circuit 710. The rotation force feedback signal represents the rotation force applied to the shaft 740. The position sensor 734 may be configured to provide the position of the closure member as a feedback signal to the control circuit 710. Additional sensors 738 such as a shaft encoder may provide the rotational position of the shaft 740 to the control circuit 710.

[0356] In one aspect, the control circuit 710 is configured to articulate the end effector 702. The control circuit 710 provides a motor set point to a motor control 708d, which provides a drive signal to the motor 704d. The output shaft of the motor 704d is coupled to a torque sensor 744d. The torque sensor 744d is coupled to a transmission 706d which is coupled to an articulation member 742a. The transmission 706d comprises movable mechanical elements such as articulation elements to control the articulation of the end effector 702±65°. In one aspect, the motor 704d is coupled to an articulation nut, which is rotatably journaled on the proximal end portion of the distal spine portion and is rotatably driven thereon by an articulation gear assembly. The torque sensor 744d provides an articulation force feedback signal to the control circuit 710. The articulation force feedback signal represents the articulation force applied to the end effector 702. Sensors 738, such as an articulation encoder, may provide the articulation position of the end effector 702 to the control circuit 710.

[0357] In another aspect, the articulation function of the robotic surgical system 700 may comprise two articulation members, or links, 742a, 742b. These articulation members 742a, 742b are driven by separate disks on the robot interface (the rack) which are driven by the two motors 708d, 708e. When the separate firing motor 704a is provided, each of articulation links 742a, 742b can be antagonistically driven with respect to the other link in order to provide a resistive holding motion and a load to the head when it is not moving and to provide an articulation motion as the head is articulated. The articulation members 742a, 742b attach to the head at a fixed radius as the head is rotated. Accordingly, the mechanical advantage of the push-and-pull link changes as the head is rotated. This change in the mechanical advantage may be more pronounced with other articulation link drive systems.

[0358] In one aspect, the one or more motors 704a-704e may comprise a brushed DC motor with a gearbox and mechanical links to a firing member, closure member, or articulation member. Another example includes electric motors 704a-704e that operate the movable mechanical

elements such as the displacement member, articulation links, closure tube, and shaft. An outside influence is an unmeasured, unpredictable influence of things like tissue, surrounding bodies, and friction on the physical system. Such outside influence can be referred to as drag, which acts in opposition to one of electric motors 704a-704e. The outside influence, such as drag, may cause the operation of the physical system to deviate from a desired operation of the physical system.

[0359] In one aspect, the position sensor 734 may be implemented as an absolute positioning system. In one aspect, the position sensor 734 may comprise a magnetic rotary absolute positioning system implemented as an AS5055EQFT single-chip magnetic rotary position sensor available from Austria Microsystems, AG. The position sensor 734 may interface with the control circuit 710 to provide an absolute positioning system. The position may include multiple Hall-effect elements located above a magnet and coupled to a CORDIC processor, also known as the digit-by-digit method and Volder's algorithm, that is provided to implement a simple and efficient algorithm to calculate hyperbolic and trigonometric functions that require only addition, subtraction, bitshift, and table lookup operations.

[0360] In one aspect, the control circuit 710 may be implemented as an absolute positioning system. In one aspect, the position sensor 734 may comprise a magnetic rotary absolute positioning system implemented as an AS5055EQFT single-chip magnetic rotary position sensor available from Austria Microsystems, AG. The position sensor 734 may interface with the control circuit 710 to provide an absolute positioning system. The position may include multiple Hall-effect elements located above a magnet and coupled to a CORDIC processor, also known as the digit-by-digit method and Volder's algorithm, that is provided to implement a simple and efficient algorithm to calculate hyperbolic and trigonometric functions that require only addition, subtraction, bitshift, and table lookup operations.

[0360] In one aspect, the control circuit 710 may be in communication with one or more sensors 738. The sensors 738 may be positioned on the end effector 702 and adapted to operate with the robotic surgical instrument 700 to measure the various derived parameters such as the gap distance versus time, tissue compression versus time, and anvil strain versus time. The sensors 738 may comprise a magnetic sensor, a magnetic field sensor, a strain gauge, a load cell, a pressure sensor, a force sensor, a torque sensor, an inductive sensor such as an eddy current sensor, a resistive sensor, a capacitive sensor, an optical sensor, and/or any other suitable sensor for measuring one or more parameters of the end effector 702. The sensors 738 may include one or more sensors. The sensors 738 may be located on the clamp arm 716 to determine tissue location using segmented electrodes. The torque sensors 744a-744e may be configured to sense force such as firing force, closure force, and/or articulation force, among others. Accordingly, the control circuit 710 can sense (1) the closure load experienced by the distal closure tube and its position, (2) the firing member at the rack and its position, (3) what portion of the ultrasonic blade 718 has tissue on it, and (4) the load and position on both articulation rods.

[0361] In one aspect, the one or more sensors 738 may comprise a strain gauge, such as a micro-strain gauge, configured to measure the magnitude of the strain in the clamp arm 716 during a clamped condition. The strain gauge provides an electrical signal whose amplitude varies with the magnitude of the strain. The sensors 738 may comprise a pressure sensor configured to detect a pressure generated by the presence of compressed tissue between the clamp arm 716 and the ultrasonic blade 718. The sensors 738 may be configured to detect impedance of a tissue section located between the clamp arm 716 and the ultrasonic blade 718 that is indicative of the thickness and/or fullness of tissue located therebetween.

[0362] In one aspect, the sensors 738 may be implemented as one or more limit switches, electromechanical devices, solid-state switches, Hall-effect devices, magneto-resistive (MR) devices, giant magneto-resistive (GMR) devices,

magnetometers, among others. In other implementations, the sensors 738 may be implemented as solid-state switches that operate under the influence of light, such as optical sensors, IR sensors, ultraviolet sensors, among others. Still, the switches may be solid-state devices such as transistors (e.g., FET, junction FET, MOSFET, bipolar, and the like). In other implementations, the sensors 738 may include electrical conductorless switches, ultrasonic switches, accelerometers, and inertial sensors, among others.

[0363] In one aspect, the sensors 738 may be configured to measure forces exerted on the clamp arm 716 by the closure drive system. For example, one or more sensors 738 can be at an interaction point between the closure tube and the clamp arm 716 to detect the closure forces applied by the closure tube to the clamp arm 716. The forces exerted on the clamp arm 716 can be representative of the tissue compression experienced by the tissue section captured between the clamp arm 716 and the ultrasonic blade 718. The one or more sensors 738 can be positioned at various interaction points along the closure drive system to detect the closure forces applied to the clamp arm 716 by the closure drive system. The one or more sensors 738 may be sampled in real time during a clamping operation by the processor of the control circuit 710. The control circuit 710 receives real-time sample measurements to provide and analyze time-based information and assess, in real time, closure forces applied to the clamp arm 716.

[0364] In one aspect, a current sensor 736 can be employed to measure the current drawn by each of the motors 704a-704e. The force required to advance any of the movable mechanical elements such as the closure member 714 corresponds to the current drawn by one of the motors 704a-704e. The force is converted to a digital signal and provided to the control circuit 710. The control circuit 710 can be configured to simulate the response of the actual system of the instrument in the software of the controller. A displacement member can be actuated to move the closure member 714 in the end effector 702 at or near a target velocity. The robotic surgical instrument 700 can include a feedback controller, which can be one of any feedback controllers, including, but not limited to a PID, a state feedback, a linear-quadratic (LQR), and/or an adaptive controller, for example. The robotic surgical instrument 700 can include a power source to convert the signal from the feedback controller into a physical input such as case voltage, PWM voltage, frequency modulated voltage, current, torque, and/or force, for example. Additional details are disclosed in U.S. patent application Ser. No. 15/636,829, titled CLOSED LOOP VELOCITY CONTROL TECHNIQUES FOR ROBOTIC SURGICAL INSTRUMENT, filed Jun. 29, 2017, which is herein incorporated by reference in its entirety.

[0365] FIG. 18 illustrates a schematic diagram of a surgical instrument 750 configured to control the distal translation of a displacement member according to one aspect of this disclosure. In one aspect, the surgical instrument 750 is programmed to control the distal translation of a displacement member such as the closure member 764. The surgical instrument 750 comprises an end effector 752 that may comprise a clamp arm 766, a closure member 764, and an ultrasonic blade 768 coupled to an ultrasonic transducer 769 driven by an ultrasonic generator 771.

[0366] The position, movement, displacement, and/or translation of a linear displacement member, such as the

closure member 764, can be measured by an absolute positioning system, sensor arrangement, and position sensor 784. Because the closure member 764 is coupled to a longitudinally movable drive member, the position of the closure member 764 can be determined by measuring the position of the longitudinally movable drive member employing the position sensor 784. Accordingly, in the following description, the position, displacement, and/or translation of the closure member 764 can be achieved by the position sensor 784 as described herein. A control circuit 760 may be programmed to control the translation of the displacement member, such as the closure member 764. The control circuit 760, in some examples, may comprise one or more microcontrollers, microprocessors, or other suitable processors for executing instructions that cause the processor or processors to control the displacement member, e.g., the closure member 764, in the manner described. In one aspect, a timer/counter 781 provides an output signal, such as the elapsed time or a digital count, to the control circuit 760 to correlate the position of the closure member 764 as determined by the position sensor 784 with the output of the timer/counter 781 such that the control circuit 760 can determine the position of the closure member 764 at a specific time (t) relative to a starting position. The timer/counter 781 may be configured to measure elapsed time, count external events, or time external events.

[0367] The control circuit 760 may generate a motor set point signal 772. The motor set point signal 772 may be provided to a motor controller 758. The motor controller 758 may comprise one or more circuits configured to provide a motor drive signal 774 to the motor 754 to drive the motor 754 as described herein. In some examples, the motor 754 may be a brushed DC electric motor. For example, the velocity of the motor 754 may be proportional to the motor drive signal 774. In some examples, the motor 754 may be a brushless DC electric motor and the motor drive signal 774 may comprise a PWM signal provided to one or more stator windings of the motor 754. Also, in some examples, the motor controller 758 may be omitted, and the control circuit 760 may generate the motor drive signal 774 directly.

[0368] The motor 754 may receive power from an energy source 762. The energy source 762 may be or include a battery, a super capacitor, or any other suitable energy source. The motor 754 may be mechanically coupled to the closure member 764 via a transmission 756. The transmission 756 may include one or more gears or other linkage components to couple the motor 754 to the closure member 764. A position sensor 784 may sense a position of the closure member 764. The position sensor 784 may be or include any type of sensor that is capable of generating position data that indicate a position of the closure member 764. In some examples, the position sensor 784 may include an encoder configured to provide a series of pulses to the control circuit 760 as the closure member 764 translates distally and proximally. The control circuit 760 may track the pulses to determine the position of the closure member 764. Other suitable position sensors may be used, including, for example, a proximity sensor. Other types of position sensors may provide other signals indicating motion of the closure member 764. Also, in some examples, the position sensor 784 may be omitted. Where the motor 754 is a stepper motor, the control circuit 760 may track the position of the closure member 764 by aggregating the number and direction of steps that the motor 754 has been instructed to

execute. The position sensor **784** may be located in the end effector **752** or at any other portion of the instrument.

[0369] The control circuit **760** may be in communication with one or more sensors **788**. The sensors **788** may be positioned on the end effector **752** and adapted to operate with the surgical instrument **750** to measure the various derived parameters such as gap distance versus time, tissue compression versus time, and anvil strain versus time. The sensors **788** may comprise a magnetic sensor, a magnetic field sensor, a strain gauge, a pressure sensor, a force sensor, an inductive sensor such as an eddy current sensor, a resistive sensor, a capacitive sensor, an optical sensor, and/or any other suitable sensor for measuring one or more parameters of the end effector **752**. The sensors **788** may include one or more sensors.

[0370] The one or more sensors **788** may comprise a strain gauge, such as a micro-strain gauge, configured to measure the magnitude of the strain in the clamp arm **766** during a clamped condition. The strain gauge provides an electrical signal whose amplitude varies with the magnitude of the strain. The sensors **788** may comprise a pressure sensor configured to detect a pressure generated by the presence of compressed tissue between the clamp arm **766** and the ultrasonic blade **768**. The sensors **788** may be configured to detect impedance of a tissue section located between the clamp arm **766** and the ultrasonic blade **768** that is indicative of the thickness and/or fullness of tissue located therebetween.

[0371] The sensors **788** may be is configured to measure forces exerted on the clamp arm **766** by a closure drive system. For example, one or more sensors **788** can be at an interaction point between a closure tube and the clamp arm **766** to detect the closure forces applied by a closure tube to the clamp arm **766**. The forces exerted on the clamp arm **766** can be representative of the tissue compression experienced by the tissue section captured between the clamp arm **766** and the ultrasonic blade **768**. The one or more sensors **788** can be positioned at various interaction points along the closure drive system to detect the closure forces applied to the clamp arm **766** by the closure drive system. The one or more sensors **788** may be sampled in real time during a clamping operation by a processor of the control circuit **760**. The control circuit **760** receives real-time sample measurements to provide and analyze time-based information and assess, in real time, closure forces applied to the clamp arm **766**.

[0372] A current sensor **786** can be employed to measure the current drawn by the motor **754**. The force required to advance the closure member **764** corresponds to the current drawn by the motor **754**. The force is converted to a digital signal and provided to the control circuit **760**.

[0373] The control circuit **760** can be configured to simulate the response of the actual system of the instrument in the software of the controller. A displacement member can be actuated to move a closure member **764** in the end effector **752** at or near a target velocity. The surgical instrument **750** can include a feedback controller, which can be one of any feedback controllers, including, but not limited to a PID, a state feedback, LQR, and/or an adaptive controller, for example. The surgical instrument **750** can include a power source to convert the signal from the feedback controller into a physical input such as case voltage, PWM voltage, frequency modulated voltage, current, torque, and/or force, for example.

[0374] The actual drive system of the surgical instrument **750** is configured to drive the displacement member, cutting member, or closure member **764**, by a brushed DC motor with gearbox and mechanical links to an articulation and/or knife system. Another example is the electric motor **754** that operates the displacement member and the articulation driver, for example, of an interchangeable shaft assembly. An outside influence is an unmeasured, unpredictable influence of things like tissue, surrounding bodies and friction on the physical system. Such outside influence can be referred to as drag which acts in opposition to the electric motor **754**. The outside influence, such as drag, may cause the operation of the physical system to deviate from a desired operation of the physical system.

[0375] Various example aspects are directed to a surgical instrument **750** comprising an end effector **752** with motor-driven surgical sealing and cutting implements. For example, a motor **754** may drive a displacement member distally and proximally along a longitudinal axis of the end effector **752**. The end effector **752** may comprise a pivotable clamp arm **766** and, when configured for use, an ultrasonic blade **768** positioned opposite the clamp arm **766**. A clinician may grasp tissue between the clamp arm **766** and the ultrasonic blade **768**, as described herein. When ready to use the instrument **750**, the clinician may provide a firing signal, for example by depressing a trigger of the instrument **750**. In response to the firing signal, the motor **754** may drive the displacement member distally along the longitudinal axis of the end effector **752** from a proximal stroke begin position to a stroke end position distal of the stroke begin position. As the displacement member translates distally, the closure member **764** with a cutting element positioned at a distal end, may cut the tissue between the ultrasonic blade **768** and the clamp arm **766**.

[0376] In various examples, the surgical instrument **750** may comprise a control circuit **760** programmed to control the distal translation of the displacement member, such as the closure member **764**, for example, based on one or more tissue conditions. The control circuit **760** may be programmed to sense tissue conditions, such as thickness, either directly or indirectly, as described herein. The control circuit **760** may be programmed to select a control program based on tissue conditions. A control program may describe the distal motion of the displacement member. Different control programs may be selected to better treat different tissue conditions. For example, when thicker tissue is present, the control circuit **760** may be programmed to translate the displacement member at a lower velocity and/or with lower power. When thinner tissue is present, the control circuit **760** may be programmed to translate the displacement member at a higher velocity and/or with higher power.

[0377] In some examples, the control circuit **760** may initially operate the motor **754** in an open loop configuration for a first open loop portion of a stroke of the displacement member. Based on a response of the instrument **750** during the open loop portion of the stroke, the control circuit **760** may select a firing control program. The response of the instrument may include, a translation distance of the displacement member during the open loop portion, a time elapsed during the open loop portion, energy provided to the motor **754** during the open loop portion, a sum of pulse widths of a motor drive signal, etc. After the open loop portion, the control circuit **760** may implement the selected firing control program for a second portion of the displacement

ment member stroke. For example, during the closed loop portion of the stroke, the control circuit 760 may modulate the motor 754 based on translation data describing a position of the displacement member in a closed loop manner to translate the displacement member at a constant velocity. Additional details are disclosed in U.S. patent application Ser. No. 15/720,852, titled SYSTEM AND METHODS FOR CONTROLLING A DISPLAY OF A SURGICAL INSTRUMENT, filed Sep. 29, 2017, which is herein incorporated by reference in its entirety.

[0378] FIG. 19 is a schematic diagram of a surgical instrument 790 configured to control various functions according to one aspect of this disclosure. In one aspect, the surgical instrument 790 is programmed to control distal translation of a displacement member such as the closure member 764. The surgical instrument 790 comprises an end effector 792 that may comprise a clamp arm 766, a closure member 764, and an ultrasonic blade 768 which may be interchanged with or work in conjunction with one or more RF electrodes 796 (shown in dashed line). The ultrasonic blade 768 is coupled to an ultrasonic transducer 769 driven by an ultrasonic generator 771.

[0379] In one aspect, sensors 788 may be implemented as a limit switch, electromechanical device, solid-state switches, Hall-effect devices, MR devices, GMR devices, magnetometers, among others. In other implementations, the sensors 638 may be solid-state switches that operate under the influence of light, such as optical sensors, IR sensors, ultraviolet sensors, among others. Still, the switches may be solid-state devices such as transistors (e.g., FET, junction FET, MOSFET, bipolar, and the like). In other implementations, the sensors 788 may include electrical conductorless switches, ultrasonic switches, accelerometers, and inertial sensors, among others.

[0380] In one aspect, the position sensor 784 may be implemented as an absolute positioning system comprising a magnetic rotary absolute positioning system implemented as an AS5055EQFT single-chip magnetic rotary position sensor available from Austria Microsystems, AG. The position sensor 784 may interface with the control circuit 760 to provide an absolute positioning system. The position may include multiple Hall-effect elements located above a magnet and coupled to a CORDIC processor, also known as the digit-by-digit method and Volder's algorithm, that is provided to implement a simple and efficient algorithm to calculate hyperbolic and trigonometric functions that require only addition, subtraction, bitshift, and table lookup operations.

[0381] In some examples, the position sensor 784 may be omitted. Where the motor 754 is a stepper motor, the control circuit 760 may track the position of the closure member 764 by aggregating the number and direction of steps that the motor has been instructed to execute. The position sensor 784 may be located in the end effector 792 or at any other portion of the instrument.

[0382] The control circuit 760 may be in communication with one or more sensors 788. The sensors 788 may be positioned on the end effector 792 and adapted to operate with the surgical instrument 790 to measure the various derived parameters such as gap distance versus time, tissue compression versus time, and anvil strain versus time. The sensors 788 may comprise a magnetic sensor, a magnetic field sensor, a strain gauge, a pressure sensor, a force sensor, an inductive sensor such as an eddy current sensor, a

resistive sensor, a capacitive sensor, an optical sensor, and/or any other suitable sensor for measuring one or more parameters of the end effector 792. The sensors 788 may include one or more sensors.

[0383] An RF energy source 794 is coupled to the end effector 792 and is applied to the RF electrode 796 when the RF electrode 796 is provided in the end effector 792 in place of the ultrasonic blade 768 or to work in conjunction with the ultrasonic blade 768. For example, the ultrasonic blade is made of electrically conductive metal and may be employed as the return path for electrosurgical RF current. The control circuit 760 controls the delivery of the RF energy to the RF electrode 796.

[0384] Additional details are disclosed in U.S. patent application Ser. No. 15/636,096, titled SURGICAL SYSTEM COUPLABLE WITH STAPLE CARTRIDGE AND RADIO FREQUENCY CARTRIDGE, AND METHOD OF USING SAME, filed Jun. 28, 2017, which is herein incorporated by reference in its entirety.

Adaptive Ultrasonic Blade Control Algorithms

[0385] In various aspects smart ultrasonic energy devices may comprise adaptive algorithms to control the operation of the ultrasonic blade. In one aspect, the ultrasonic blade adaptive control algorithms are configured to identify tissue type and adjust device parameters. In one aspect, the ultrasonic blade control algorithms are configured to parameterize tissue type. An algorithm to detect the collagen/elastic ratio of tissue to tune the amplitude of the distal tip of the ultrasonic blade is described in the following section of the present disclosure. Various aspects of smart ultrasonic energy devices are described herein in connection with FIGS. 1-94, for example. Accordingly, the following description of adaptive ultrasonic blade control algorithms should be read in conjunction with FIGS. 1-94 and the description associated therewith.

Tissue Type Identification and Device Parameter Adjustments

[0386] In certain surgical procedures it would be desirable to employ adaptive ultrasonic blade control algorithms. In one aspect, adaptive ultrasonic blade control algorithms may be employed to adjust the parameters of the ultrasonic device based on the type of tissue in contact with the ultrasonic blade. In one aspect, the parameters of the ultrasonic device may be adjusted based on the location of the tissue within the jaws of the ultrasonic end effector, for example, the location of the tissue between the clamp arm and the ultrasonic blade. The impedance of the ultrasonic transducer may be employed to differentiate what percentage of the tissue is located in the distal or proximal end of the end effector. The reactions of the ultrasonic device may be based on the tissue type or compressibility of the tissue. In another aspect, the parameters of the ultrasonic device may be adjusted based on the identified tissue type or parameterization. For example, the mechanical displacement amplitude of the distal tip of the ultrasonic blade may be tuned based on the ration of collagen to elastin tissue detected during the tissue identification procedure. The ratio of collagen to elastin tissue may be detected used a variety of techniques including infrared (IR) surface reflectance and emissivity. The force applied to the tissue by the clamp arm and/or the stroke of the clamp arm to produce gap and

compression. Electrical continuity across a jaw equipped with electrodes may be employed to determine what percentage of the jaw is covered with tissue.

[0387] FIG. 20 is a system 800 configured to execute adaptive ultrasonic blade control algorithms in a surgical data network comprising a modular communication hub, in accordance with at least one aspect of the present disclosure. In one aspect, the generator module 240 is configured to execute the adaptive ultrasonic blade control algorithm(s) 802 as described herein with reference to FIGS. 53-94. In another aspect, the device/instrument 235 is configured to execute the adaptive ultrasonic blade control algorithm(s) 804 as described herein with reference to FIGS. 53-94. In another aspect, both the device/instrument 235 and the device/instrument 235 are configured to execute the adaptive ultrasonic blade control algorithms 802, 804 as described herein with reference to FIGS. 53-94.

[0388] The generator module 240 may comprise a patient isolated stage in communication with a non-isolated stage via a power transformer. A secondary winding of the power transformer is contained in the isolated stage and may comprise a tapped configuration (e.g., a center-tapped or a non-center-tapped configuration) to define drive signal outputs for delivering drive signals to different surgical instruments, such as, for example, an ultrasonic surgical instrument, an RF electrosurgical instrument, and a multifunction surgical instrument which includes ultrasonic and RF energy modes that can be delivered alone or simultaneously. In particular, the drive signal outputs may output an ultrasonic drive signal (e.g., a 420V root-mean-square (RMS) drive signal) to an ultrasonic surgical instrument 241, and the drive signal outputs may output an RF electrosurgical drive signal (e.g., a 100V RMS drive signal) to an RF electrosurgical instrument 241. Aspects of the generator module 240 are described herein with reference to FIGS. 21-28B.

[0389] The generator module 240 or the device/instrument 235 or both are coupled to the modular control tower 236 connected to multiple operating theater devices such as, for example, intelligent surgical instruments, robots, and other computerized devices located in the operating theater, as described with reference to FIGS. 8-11, for example.

[0390] FIG. 21 illustrates an example of a generator 900, which is one form of a generator configured to couple to an ultrasonic instrument and further configured to execute adaptive ultrasonic blade control algorithms in a surgical data network comprising a modular communication hub as shown in FIG. 20. The generator 900 is configured to deliver multiple energy modalities to a surgical instrument. The generator 900 provides RF and ultrasonic signals for delivering energy to a surgical instrument either independently or simultaneously. The RF and ultrasonic signals may be provided alone or in combination and may be provided simultaneously. As noted above, at least one generator output can deliver multiple energy modalities (e.g., ultrasonic, bipolar or monopolar RF, irreversible and/or reversible electroporation, and/or microwave energy, among others) through a single port, and these signals can be delivered separately or simultaneously to the end effector to treat tissue. The generator 900 comprises a processor 902 coupled to a waveform generator 904. The processor 902 and waveform generator 904 are configured to generate a variety of signal waveforms based on information stored in a memory coupled to the processor 902, not shown for clarity of disclosure. The digital information associated with a wave-

form is provided to the waveform generator 904 which includes one or more DAC circuits to convert the digital input into an analog output. The analog output is fed to an amplifier 1106 for signal conditioning and amplification. The conditioned and amplified output of the amplifier 906 is coupled to a power transformer 908. The signals are coupled across the power transformer 908 to the secondary side, which is in the patient isolation side. A first signal of a first energy modality is provided to the surgical instrument between the terminals labeled ENERGY₁ and RETURN. A second signal of a second energy modality is coupled across a capacitor 910 and is provided to the surgical instrument between the terminals labeled ENERGY₂ and RETURN. It will be appreciated that more than two energy modalities may be output and thus the subscript "n" may be used to designate that up to n ENERGY_n terminals may be provided, where n is a positive integer greater than 1. It also will be appreciated that up to "n" return paths RETURN_n may be provided without departing from the scope of the present disclosure.

[0391] A first voltage sensing circuit 912 is coupled across the terminals labeled ENERGY₁ and the RETURN path to measure the output voltage therebetween. A second voltage sensing circuit 924 is coupled across the terminals labeled ENERGY₂ and the RETURN path to measure the output voltage therebetween. A current sensing circuit 914 is disposed in series with the RETURN leg of the secondary side of the power transformer 908 as shown to measure the output current for either energy modality. If different return paths are provided for each energy modality, then a separate current sensing circuit should be provided in each return leg. The outputs of the first and second voltage sensing circuits 912, 924 are provided to respective isolation transformers 916, 922 and the output of the current sensing circuit 914 is provided to another isolation transformer 918. The outputs of the isolation transformers 916, 928, 922 in the on the primary side of the power transformer 908 (non-patient isolated side) are provided to a one or more ADC circuit 926. The digitized output of the ADC circuit 926 is provided to the processor 902 for further processing and computation. The output voltages and output current feedback information can be employed to adjust the output voltage and current provided to the surgical instrument and to compute output impedance, among other parameters. Input/output communications between the processor 902 and patient isolated circuits is provided through an interface circuit 920. Sensors also may be in electrical communication with the processor 902 by way of the interface circuit 920.

[0392] In one aspect, the impedance may be determined by the processor 902 by dividing the output of either the first voltage sensing circuit 912 coupled across the terminals labeled ENERGY₁/RETURN or the second voltage sensing circuit 924 coupled across the terminals labeled ENERGY₂/RETURN by the output of the current sensing circuit 914 disposed in series with the RETURN leg of the secondary side of the power transformer 908. The outputs of the first and second voltage sensing circuits 912, 924 are provided to separate isolation transformers 916, 922 and the output of the current sensing circuit 914 is provided to another isolation transformer 916. The digitized voltage and current sensing measurements from the ADC circuit 926 are provided the processor 902 for computing impedance. As an example, the first energy modality ENERGY₁ may be ultrasonic energy and the second energy modality ENERGY₂

may be RF energy. Nevertheless, in addition to ultrasonic and bipolar or monopolar RF energy modalities, other energy modalities include irreversible and/or reversible electroporation and/or microwave energy, among others. Also, although the example illustrated in FIG. 21 shows a single return path RETURN may be provided for two or more energy modalities, in other aspects, multiple return paths RETURN_n may be provided for each energy modality ENERGY_n. Thus, as described herein, the ultrasonic transducer impedance may be measured by dividing the output of the first voltage sensing circuit 912 by the current sensing circuit 914 and the tissue impedance may be measured by dividing the output of the second voltage sensing circuit 924 by the current sensing circuit 914.

[0393] As shown in FIG. 21, the generator 900 comprising at least one output port can include a power transformer 908 with a single output and with multiple taps to provide power in the form of one or more energy modalities, such as ultrasonic, bipolar or monopolar RF, irreversible and/or reversible electroporation, and/or microwave energy, among others, for example, to the end effector depending on the type of treatment of tissue being performed. For example, the generator 900 can deliver energy with higher voltage and lower current to drive an ultrasonic transducer, with lower voltage and higher current to drive RF electrodes for sealing tissue, or with a coagulation waveform for spot coagulation using either monopolar or bipolar RF electrosurgical electrodes. The output waveform from the generator 900 can be steered, switched, or filtered to provide the frequency to the end effector of the surgical instrument. The connection of an ultrasonic transducer to the generator 900 output would be preferably located between the output labeled ENERGY₁ and RETURN as shown in FIG. 21. In one example, a connection of RF bipolar electrodes to the generator 900 output would be preferably located between the output labeled ENERGY₂ and RETURN. In the case of monopolar output, the preferred connections would be active electrode (e.g., pencil or other probe) to the ENERGY₂ output and a suitable return pad connected to the RETURN output.

[0394] Additional details are disclosed in U.S. Patent Application Publication No. 2017/0086914, titled TECHNIQUES FOR OPERATING GENERATOR FOR DIGITALLY GENERATING ELECTRICAL SIGNAL WAVEFORMS AND SURGICAL INSTRUMENTS, which published on Mar. 30, 2017, which is herein incorporated by reference in its entirety.

[0395] As used throughout this description, the term “wireless” and its derivatives may be used to describe circuits, devices, systems, methods, techniques, communications channels, etc., that may communicate data through the use of modulated electromagnetic radiation through a non-solid medium. The term does not imply that the associated devices do not contain any wires, although in some aspects they might not. The communication module may implement any of a number of wireless or wired communication standards or protocols, including but not limited to Wi-Fi (IEEE 802.11 family), WiMAX (IEEE 802.16 family), IEEE 802.20, long term evolution (LTE), Ev-DO, HSPA+, HSDPA+, HSUPA+, EDGE, GSM, GPRS, CDMA, TDMA, DECT, Bluetooth, Ethernet derivatives thereof, as well as any other wireless and wired protocols that are designated as 3G, 4G, 5G, and beyond. The computing module may include a plurality of communication modules. For instance, a first communication module may be dedi-

cated to shorter range wireless communications such as Wi-Fi and Bluetooth and a second communication module may be dedicated to longer range wireless communications such as GPS, EDGE, GPRS, CDMA, WMAX, LTE, Ev-DO, and others.

[0396] As used herein a processor or processing unit is an electronic circuit which performs operations on some external data source, usually memory or some other data stream. The term is used herein to refer to the central processor (central processing unit) in a system or computer systems (especially systems on a chip (SoCs)) that combine a number of specialized “processors.”

[0397] As used herein, a system on a chip or system on chip (SoC or SOC) is an integrated circuit (also known as an “IC” or “chip”) that integrates all components of a computer or other electronic systems. It may contain digital, analog, mixed-signal, and often radio-frequency functions—all on a single substrate. A SoC integrates a microcontroller (or microprocessor) with advanced peripherals like graphics processing unit (GPU), W-Fi module, or coprocessor. A SoC may or may not contain built-in memory.

[0398] As used herein, a microcontroller or controller is a system that integrates a microprocessor with peripheral circuits and memory. A microcontroller (or MCU for microcontroller unit) may be implemented as a small computer on a single integrated circuit. It may be similar to a SoC; an SoC may include a microcontroller as one of its components. A microcontroller may contain one or more core processing units (CPUs) along with memory and programmable input/output peripherals. Program memory in the form of Ferroelectric RAM, NOR flash or OTP ROM is also often included on chip, as well as a small amount of RAM. Microcontrollers may be employed for embedded applications, in contrast to the microprocessors used in personal computers or other general purpose applications consisting of various discrete chips.

[0399] As used herein, the term controller or microcontroller may be a stand-alone IC or chip device that interfaces with a peripheral device. This may be a link between two parts of a computer or a controller on an external device that manages the operation of (and connection with) that device.

[0400] Any of the processors or microcontrollers described herein, may be implemented by any single core or multicore processor such as those known under the trade name ARM Cortex by Texas Instruments. In one aspect, the processor may be an LM4F230H5QR ARM Cortex-M4F Processor Core, available from Texas Instruments, for example, comprising on-chip memory of 256 KB single-cycle flash memory, or other non-volatile memory, up to 40 MHz, a prefetch buffer to improve performance above 40 MHz, a 32 KB single-cycle serial random access memory (SRAM), internal read-only memory (ROM) loaded with StellarisWare® software, 2 KB electrically erasable programmable read-only memory (EEPROM), one or more pulse width modulation (PWM) modules, one or more quadrature encoder inputs (QEI) analog, one or more 12-bit Analog-to-Digital Converters (ADC) with 12 analog input channels, details of which are available for the product datasheet.

[0401] In one aspect, the processor may comprise a safety controller comprising two controller-based families such as TMS570 and RM4x known under the trade name Hercules ARM Cortex R4, also by Texas Instruments. The safety controller may be configured specifically for IEC 61508 and

ISO 26262 safety critical applications, among others, to provide advanced integrated safety features while delivering scalable performance, connectivity, and memory options.

[0402] Modular devices include the modules (as described in connection with FIGS. 3 and 9, for example) that are receivable within a surgical hub and the surgical devices or instruments that can be connected to the various modules in order to connect or pair with the corresponding surgical hub. The modular devices include, for example, intelligent surgical instruments, medical imaging devices, suction/irrigation devices, smoke evacuators, energy generators, ventilators, insufflators, and displays. The modular devices described herein can be controlled by control algorithms. The control algorithms can be executed on the modular device itself, on the surgical hub to which the particular modular device is paired, or on both the modular device and the surgical hub (e.g., via a distributed computing architecture). In some exemplifications, the modular devices' control algorithms control the devices based on data sensed by the modular device itself (i.e., by sensors in, on, or connected to the modular device). This data can be related to the patient being operated on (e.g., tissue properties or insufflation pressure) or the modular device itself (e.g., the rate at which a knife is being advanced, motor current, or energy levels). For example, a control algorithm for a surgical stapling and cutting instrument can control the rate at which the instrument's motor drives its knife through tissue according to resistance encountered by the knife as it advances.

[0403] FIG. 22 illustrates one form of a surgical system 1000 comprising a generator 1100 and various surgical instruments 1104, 1106, 1108 usable therewith, where the surgical instrument 1104 is an ultrasonic surgical instrument, the surgical instrument 1106 is an RF electro-surgical instrument, and the multifunction surgical instrument 1108 is a combination ultrasonic/RF electro-surgical instrument. The generator 1100 is configurable for use with a variety of surgical instruments. According to various forms, the generator 1100 may be configurable for use with different surgical instruments of different types including, for example, ultrasonic surgical instruments 1104, RF electro-surgical instruments 1106, and multifunction surgical instruments 1108 that integrate RF and ultrasonic energies delivered simultaneously from the generator 1100. Although in the form of FIG. 22 the generator 1100 is shown separate from the surgical instruments 1104, 1106, 1108 in one form, the generator 1100 may be formed integrally with any of the surgical instruments 1104, 1106, 1108 to form a unitary surgical system. The generator 1100 comprises an input device 1110 located on a front panel of the generator 1100 console. The input device 1110 may comprise any suitable device that generates signals suitable for programming the operation of the generator 1100. The generator 1100 may be configured for wired or wireless communication.

[0404] The generator 1100 is configured to drive multiple surgical instruments 1104, 1106, 1108. The first surgical instrument is an ultrasonic surgical instrument 1104 and comprises a handpiece 1105 (HP), an ultrasonic transducer 1120, a shaft 1126, and an end effector 1122. The end effector 1122 comprises an ultrasonic blade 1128 acoustically coupled to the ultrasonic transducer 1120 and a clamp arm 1140. The handpiece 1105 comprises a trigger 1143 to operate the clamp arm 1140 and a combination of the toggle buttons 1134a, 1134b, 1134c to energize and drive the

ultrasonic blade 1128 or other function. The toggle buttons 1134a, 1134b, 1134c can be configured to energize the ultrasonic transducer 1120 with the generator 1100.

[0405] The generator 1100 also is configured to drive a second surgical instrument 1106. The second surgical instrument 1106 is an RF electro-surgical instrument and comprises a handpiece 1107 (HP), a shaft 1127, and an end effector 1124. The end effector 1124 comprises electrodes in clamp arms 1142a, 1142b and return through an electrical conductor portion of the shaft 1127. The electrodes are coupled to and energized by a bipolar energy source within the generator 1100. The handpiece 1107 comprises a trigger 1145 to operate the clamp arms 1142a, 1142b and an energy button 1135 to actuate an energy switch to energize the electrodes in the end effector 1124.

[0406] The generator 1100 also is configured to drive a multifunction surgical instrument 1108. The multifunction surgical instrument 1108 comprises a handpiece 1109 (HP), a shaft 1129, and an end effector 1125. The end effector 1125 comprises an ultrasonic blade 1149 and a clamp arm 1146. The ultrasonic blade 1149 is acoustically coupled to the ultrasonic transducer 1120. The handpiece 1109 comprises a trigger 1147 to operate the clamp arm 1146 and a combination of the toggle buttons 1137a, 1137b, 1137c to energize and drive the ultrasonic blade 1149 or other function. The toggle buttons 1137a, 1137b, 1137c can be configured to energize the ultrasonic transducer 1120 with the generator 1100 and energize the ultrasonic blade 1149 with a bipolar energy source also contained within the generator 1100.

[0407] The generator 1100 is configurable for use with a variety of surgical instruments. According to various forms, the generator 1100 may be configurable for use with different surgical instruments of different types including, for example, the ultrasonic surgical instrument 1104, the RF electro-surgical instrument 1106, and the multifunction surgical instrument 1108 that integrates RF and ultrasonic energies delivered simultaneously from the generator 1100. Although in the form of FIG. 22 the generator 1100 is shown separate from the surgical instruments 1104, 1106, 1108, in another form the generator 1100 may be formed integrally with any one of the surgical instruments 1104, 1106, 1108 to form a unitary surgical system. As discussed above, the generator 1100 comprises an input device 1110 located on a front panel of the generator 1100 console. The input device 1110 may comprise any suitable device that generates signals suitable for programming the operation of the generator 1100. The generator 1100 also may comprise one or more output devices 1112. Further aspects of generators for digitally generating electrical signal waveforms and surgical instruments are described in US patent publication US-2017-0086914-A1, which is herein incorporated by reference in its entirety.

[0408] FIG. 23 is an end effector 1122 of the example ultrasonic device 1104, in accordance with at least one aspect of the present disclosure. The end effector 1122 may comprise a blade 1128 that may be coupled to the ultrasonic transducer 1120 via a wave guide. When driven by the ultrasonic transducer 1120, the blade 1128 may vibrate and, when brought into contact with tissue, may cut and/or coagulate the tissue, as described herein. According to various aspects, and as illustrated in FIG. 23, the end effector 1122 may also comprise a clamp arm 1140 that may be configured for cooperative action with the blade 1128 of the end effector 1122. With the blade 1128, the clamp arm 1140

may comprise a set of jaws. The clamp arm **1140** may be pivotally connected at a distal end of a shaft **1126** of the instrument portion **1104**. The clamp arm **1140** may include a clamp arm tissue pad **1163**, which may be formed from TEFLON® or other suitable low-friction material. The pad **1163** may be mounted for cooperation with the blade **1128**, with pivotal movement of the clamp arm **1140** positioning the clamp pad **1163** in substantially parallel relationship to, and in contact with, the blade **1128**. By this construction, a tissue bite to be clamped may be grasped between the tissue pad **1163** and the blade **1128**. The tissue pad **1163** may be provided with a sawtooth-like configuration including a plurality of axially spaced, proximally extending gripping teeth **1161** to enhance the gripping of tissue in cooperation with the blade **1128**. The clamp arm **1140** may transition from the open position shown in FIG. 23 to a closed position (with the clamp arm **1140** in contact with or proximity to the blade **1128**) in any suitable manner. For example, the handpiece **1105** may comprise a jaw closure trigger. When actuated by a clinician, the jaw closure trigger may pivot the clamp arm **1140** in any suitable manner.

[0409] The generator **1100** may be activated to provide the drive signal to the ultrasonic transducer **1120** in any suitable manner. For example, the generator **1100** may comprise a foot switch **1430** (FIG. 24) coupled to the generator **1100** via a footswitch cable **1432**. A clinician may activate the ultrasonic transducer **1120**, and thereby the ultrasonic transducer **1120** and blade **1128**, by depressing the foot switch **1430**. In addition, or instead of the foot switch **1430**, some aspects of the device **1104** may utilize one or more switches positioned on the handpiece **1105** that, when activated, may cause the generator **1100** to activate the ultrasonic transducer **1120**. In one aspect, for example, the one or more switches may comprise a pair of toggle buttons **1134a**, **1134b**, **1134c** (FIG. 22), for example, to determine an operating mode of the device **1104**. When the toggle button **1134a** is depressed, for example, the ultrasonic generator **1100** may provide a maximum drive signal to the ultrasonic transducer **1120**, causing it to produce maximum ultrasonic energy output. Depressing toggle button **1134b** may cause the ultrasonic generator **1100** to provide a user-selectable drive signal to the ultrasonic transducer **1120**, causing it to produce less than the maximum ultrasonic energy output. The device **1104** additionally or alternatively may comprise a second switch to, for example, indicate a position of a jaw closure trigger for operating the jaws via the clamp arm **1140** of the end effector **1122**. Also, in some aspects, the ultrasonic generator **1100** may be activated based on the position of the jaw closure trigger, (e.g., as the clinician depresses the jaw closure trigger to close the jaws via the clamp arm **1140**, ultrasonic energy may be applied).

[0410] Additionally or alternatively, the one or more switches may comprise a toggle button **1134c** that, when depressed, causes the generator **1100** to provide a pulsed output (FIG. 22). The pulses may be provided at any suitable frequency and grouping, for example. In certain aspects, the power level of the pulses may be the power levels associated with toggle buttons **1134a**, **1134b** (maximum, less than maximum), for example.

[0411] It will be appreciated that a device **1104** may comprise any combination of the toggle buttons **1134a**, **1134b**, **1134c** (FIG. 22). For example, the device **1104** could be configured to have only two toggle buttons: a toggle button **1134a** for producing maximum ultrasonic energy

output and a toggle button **1134c** for producing a pulsed output at either the maximum or less than maximum power level per. In this way, the drive signal output configuration of the generator **1100** could be five continuous signals, or any discrete number of individual pulsed signals (1, 2, 3, 4, or 5). In certain aspects, the specific drive signal configuration may be controlled based upon, for example, EEPROM settings in the generator **1100** and/or user power level selection(s).

[0412] In certain aspects, a two-position switch may be provided as an alternative to a toggle button **1134c** (FIG. 22). For example, a device **1104** may include a toggle button **1134a** for producing a continuous output at a maximum power level and a two-position toggle button **1134b**. In a first detented position, toggle button **1134b** may produce a continuous output at a less than maximum power level, and in a second detented position the toggle button **1134b** may produce a pulsed output (e.g., at either a maximum or less than maximum power level, depending upon the EEPROM settings).

[0413] In some aspects, the RF electrosurgical end effector **1124**, **1125** (FIG. 22) may also comprise a pair of electrodes. The electrodes may be in communication with the generator **1100**, for example, via a cable. The electrodes may be used, for example, to measure an impedance of a tissue bite present between the clamp arm **1142a**, **1146** and the blade **1142b**, **1149**. The generator **1100** may provide a signal (e.g., a non-therapeutic signal) to the electrodes. The impedance of the tissue bite may be found, for example, by monitoring the current, voltage, etc. of the signal.

[0414] In various aspects, the generator **1100** may comprise several separate functional elements, such as modules and/or blocks, as shown in FIG. 24, a diagram of the surgical system **1000** of FIG. 22. Different functional elements or modules may be configured for driving the different kinds of surgical devices **1104**, **1106**, **1108**. For example an ultrasonic generator module may drive an ultrasonic device, such as the ultrasonic device **1104**. An electrosurgery/RF generator module may drive the electrosurgical device **1106**. The modules may generate respective drive signals for driving the surgical devices **1104**, **1106**, **1108**. In various aspects, the ultrasonic generator module and/or the electrosurgery/RF generator module each may be formed integrally with the generator **1100**. Alternatively, one or more of the modules may be provided as a separate circuit module electrically coupled to the generator **1100**. (The modules are shown in phantom to illustrate this option.) Also, in some aspects, the electrosurgery/RF generator module may be formed integrally with the ultrasonic generator module, or vice versa.

[0415] In accordance with the described aspects, the ultrasonic generator module may produce a drive signal or signals of particular voltages, currents, and frequencies (e.g. 55,500 cycles per second, or Hz). The drive signal or signals may be provided to the ultrasonic device **1104**, and specifically to the transducer **1120**, which may operate, for example, as described above. In one aspect, the generator **1100** may be configured to produce a drive signal of a particular voltage, current, and/or frequency output signal that can be stepped with high resolution, accuracy, and repeatability.

[0416] In accordance with the described aspects, the electrosurgery/RF generator module may generate a drive signal or signals with output power sufficient to perform bipolar electrosurgery using radio frequency (RF) energy. In bipolar

electrosurgery applications, the drive signal may be provided, for example, to the electrodes of the electrosurgical device **1106**, for example, as described above. Accordingly, the generator **1100** may be configured for therapeutic purposes by applying electrical energy to the tissue sufficient for treating the tissue (e.g., coagulation, cauterization, tissue welding, etc.).

[0417] The generator **1100** may comprise an input device **2150** (FIG. 27B) located, for example, on a front panel of the generator **1100** console. The input device **2150** may comprise any suitable device that generates signals suitable for programming the operation of the generator **1100**. In operation, the user can program or otherwise control operation of the generator **1100** using the input device **2150**. The input device **2150** may comprise any suitable device that generates signals that can be used by the generator (e.g., by one or more processors contained in the generator) to control the operation of the generator **1100** (e.g., operation of the ultrasonic generator module and/or electrosurgery/RF generator module). In various aspects, the input device **2150** includes one or more of: buttons, switches, thumbwheels, keyboard, keypad, touch screen monitor, pointing device, remote connection to a general purpose or dedicated computer. In other aspects, the input device **2150** may comprise a suitable user interface, such as one or more user interface screens displayed on a touch screen monitor, for example. Accordingly, by way of the input device **2150**, the user can set or program various operating parameters of the generator, such as, for example, current (I), voltage (V), frequency (f), and/or period (T) of a drive signal or signals generated by the ultrasonic generator module and/or electrosurgery/RF generator module.

[0418] The generator **1100** may also comprise an output device **2140** (FIG. 27B) located, for example, on a front panel of the generator **1100** console. The output device **2140** includes one or more devices for providing a sensory feedback to a user. Such devices may comprise, for example, visual feedback devices (e.g., an LCD display screen, LED indicators), audio feedback devices (e.g., a speaker, a buzzer) or tactile feedback devices (e.g., haptic actuators).

[0419] Although certain modules and/or blocks of the generator **1100** may be described by way of example, it can be appreciated that a greater or lesser number of modules and/or blocks may be used and still fall within the scope of the aspects. Further, although various aspects may be described in terms of modules and/or blocks to facilitate description, such modules and/or blocks may be implemented by one or more hardware components, e.g., processors, Digital Signal Processors (DSPs), Programmable Logic Devices (PLDs), Application Specific Integrated Circuits (ASICs), circuits, registers and/or software components, e.g., programs, subroutines, logic and/or combinations of hardware and software components.

[0420] In one aspect, the ultrasonic generator drive module and electrosurgery/RF drive module **1110** (FIG. 22) may comprise one or more embedded applications implemented as firmware, software, hardware, or any combination thereof. The modules may comprise various executable modules such as software, programs, data, drivers, application program interfaces (APIs), and so forth. The firmware may be stored in nonvolatile memory (NVM), such as in bit-masked read-only memory (ROM) or flash memory. In various implementations, storing the firmware in ROM may preserve flash memory. The NVM may comprise other types

of memory including, for example, programmable ROM (PROM), erasable programmable ROM (EPROM), electrically erasable programmable ROM (EEPROM), or battery backed random-access memory (RAM) such as dynamic RAM (DRAM), Double-Data-Rate DRAM (DDRAM), and/or synchronous DRAM (SDRAM).

[0421] In one aspect, the modules comprise a hardware component implemented as a processor for executing program instructions for monitoring various measurable characteristics of the devices **1104**, **1106**, **1108** and generating a corresponding output drive signal or signals for operating the devices **1104**, **1106**, **1108**. In aspects in which the generator **1100** is used in conjunction with the device **1104**, the drive signal may drive the ultrasonic transducer **1120** in cutting and/or coagulation operating modes. Electrical characteristics of the device **1104** and/or tissue may be measured and used to control operational aspects of the generator **1100** and/or provided as feedback to the user. In aspects in which the generator **1100** is used in conjunction with the device **1106**, the drive signal may supply electrical energy (e.g., RF energy) to the end effector **1124** in cutting, coagulation and/or desiccation modes. Electrical characteristics of the device **1106** and/or tissue may be measured and used to control operational aspects of the generator **1100** and/or provided as feedback to the user. In various aspects, as previously discussed, the hardware components may be implemented as DSP, PLD, ASIC, circuits, and/or registers. In one aspect, the processor may be configured to store and execute computer software program instructions to generate the step function output signals for driving various components of the devices **1104**, **1106**, **1108**, such as the ultrasonic transducer **1120** and the end effectors **1122**, **1124**, **1125**.

[0422] An electromechanical ultrasonic system includes an ultrasonic transducer, a waveguide, and an ultrasonic blade. The electromechanical ultrasonic system has an initial resonant frequency defined by the physical properties of the ultrasonic transducer, the waveguide, and the ultrasonic blade. The ultrasonic transducer is excited by an alternating voltage $V_g(t)$ and current $I_g(t)$ signal equal to the resonant frequency of the electromechanical ultrasonic system. When the electromechanical ultrasonic system is at resonance, the phase difference between the voltage $V_g(t)$ and current $I_g(t)$ signals is zero. Stated another way, at resonance the inductive impedance is equal to the capacitive impedance. As the ultrasonic blade heats up, the compliance of the ultrasonic blade (modeled as an equivalent capacitance) causes the resonant frequency of the electromechanical ultrasonic system to shift. Thus, the inductive impedance is no longer equal to the capacitive impedance causing a mismatch between the drive frequency and the resonant frequency of the electromechanical ultrasonic system. The system is now operating "off-resonance." The mismatch between the drive frequency and the resonant frequency is manifested as a phase difference between the voltage $V_g(t)$ and current $I_g(t)$ signals applied to the ultrasonic transducer. The generator electronics can easily monitor the phase difference between the voltage $V_g(t)$ and current $I_g(t)$ signals and can continuously adjust the drive frequency until the phase difference is once again zero. At this point, the new drive frequency is equal to the new resonant frequency of the electromechanical ultrasonic system. The change in phase and/or frequency can be used as an indirect measurement of the ultrasonic blade temperature.

[0423] As shown in FIG. 25, the electromechanical properties of the ultrasonic transducer may be modeled as an equivalent circuit comprising a first branch having a static capacitance and a second “motional” branch having a serially connected inductance, resistance and capacitance that define the electromechanical properties of a resonator. Known ultrasonic generators may include a tuning inductor for tuning out the static capacitance at a resonant frequency so that substantially all of generator’s drive signal current flows into the motional branch. Accordingly, by using a tuning inductor, the generator’s drive signal current represents the motional branch current, and the generator is thus able to control its drive signal to maintain the ultrasonic transducer’s resonant frequency. The tuning inductor may also transform the phase impedance plot of the ultrasonic transducer to improve the generator’s frequency lock capabilities. However, the tuning inductor must be matched with the specific static capacitance of an ultrasonic transducer at the operational resonance frequency. In other words, a different ultrasonic transducer having a different static capacitance requires a different tuning inductor.

[0424] FIG. 25 illustrates an equivalent circuit 1500 of an ultrasonic transducer, such as the ultrasonic transducer 1120, according to one aspect. The circuit 1500 comprises a first “motional” branch having a serially connected inductance L_s , resistance R_s and capacitance C_s that define the electromechanical properties of the resonator, and a second capacitive branch having a static capacitance C_0 . Drive current $I_g(t)$ may be received from a generator at a drive voltage $V_g(t)$, with motional current $I_m(t)$ flowing through the first branch and current $I_g(t) - I_m(t)$ flowing through the capacitive branch. Control of the electromechanical properties of the ultrasonic transducer may be achieved by suitably controlling $I_g(t)$ and $V_g(t)$. As explained above, known generator architectures may include a tuning inductor L_t (shown in phantom in FIG. 25) in a parallel resonance circuit for tuning out the static capacitance C_0 at a resonant frequency so that substantially all of the generator’s current output $I_g(t)$ flows through the motional branch. In this way, control of the motional branch current $I_m(t)$ is achieved by controlling the generator current output $I_g(t)$. The tuning inductor L_t is specific to the static capacitance C_0 of an ultrasonic transducer, however, and a different ultrasonic transducer having a different static capacitance requires a different tuning inductor L_t . Moreover, because the tuning inductor L_t is matched to the nominal value of the static capacitance C_0 at a single resonant frequency, accurate control of the motional branch current $I_m(t)$ is assured only at that frequency. As frequency shifts down with transducer temperature, accurate control of the motional branch current is compromised.

[0425] Various aspects of the generator 1100 may not rely on a tuning inductor L_t to monitor the motional branch current $I_m(t)$. Instead, the generator 1100 may use the measured value of the static capacitance C_0 in between applications of power for a specific ultrasonic surgical device 1104 (along with drive signal voltage and current feedback data) to determine values of the motional branch current/A on a dynamic and ongoing basis (e.g., in real-time). Such aspects of the generator 1100 are therefore able to provide virtual tuning to simulate a system that is tuned or resonant with any value of static capacitance C_0 at any frequency, and not just at a single resonant frequency dictated by a nominal value of the static capacitance C_0 .

[0426] FIG. 26 is a simplified block diagram of one aspect of the generator 1100 for providing inductorless tuning as described above, among other benefits. FIGS. 27A-27C illustrate an architecture of the generator 1100 of FIG. 26 according to one aspect. With reference to FIG. 26, the generator 1100 may comprise a patient isolated stage 1520 in communication with a non-isolated stage 1540 via a power transformer 1560. A secondary winding 1580 of the power transformer 1560 is contained in the isolated stage 1520 and may comprise a tapped configuration (e.g., a center-tapped or non-center tapped configuration) to define drive signal outputs 1600a, 1600b, 1600c for outputting drive signals to different surgical devices, such as, for example, an ultrasonic surgical device 1104 and an electro-surgical device 1106. In particular, drive signal outputs 1600a, 1600b, 1600c may output a drive signal (e.g., a 420V RMS drive signal) to an ultrasonic surgical device 1104, and drive signal outputs 1600a, 1600b, 1600c may output a drive signal (e.g., a 100V RMS drive signal) to an electrosurgical device 1106, with output 1600b corresponding to the center tap of the power transformer 1560. The non-isolated stage 1540 may comprise a power amplifier 1620 having an output connected to a primary winding 1640 of the power transformer 1560. In certain aspects the power amplifier 1620 may comprise a push-pull amplifier, for example. The non-isolated stage 1540 may further comprise a programmable logic device 1660 for supplying a digital output to a digital-to-analog converter (DAC) 1680, which in turn supplies a corresponding analog signal to an input of the power amplifier 1620. In certain aspects the programmable logic device 1660 may comprise a field-programmable gate array (FPGA), for example. The programmable logic device 1660, by virtue of controlling the power amplifier’s 1620 input via the DAC 1680, may therefore control any of a number of parameters (e.g., frequency, waveform shape, waveform amplitude) of drive signals appearing at the drive signal outputs 1600a, 1600b, 1600c. In certain aspects and as discussed below, the programmable logic device 1660, in conjunction with a processor (e.g., processor 1740 discussed below), may implement a number of digital signal processing (DSP)-based and/or other control algorithms to control parameters of the drive signals output by the generator 1100.

[0427] Power may be supplied to a power rail of the power amplifier 1620 by a switch-mode regulator 1700. In certain aspects the switch-mode regulator 1700 may comprise an adjustable buck regulator, for example. As discussed above, the non-isolated stage 1540 may further comprise a processor 1740, which in one aspect may comprise a DSP processor such as an ADSP-21469 SHARC DSP, available from Analog Devices, Norwood, Mass., for example. In certain aspects the processor 1740 may control operation of the switch-mode power converter 1700 responsive to voltage feedback data received from the power amplifier 1620 by the processor 1740 via an analog-to-digital converter (ADC) 1760. In one aspect, for example, the processor 1740 may receive as input, via the ADC 1760, the waveform envelope of a signal (e.g., an RF signal) being amplified by the power amplifier 1620. The processor 1740 may then control the switch-mode regulator 1700 (e.g., via a pulse-width modulated (PWM) output) such that the rail voltage supplied to the power amplifier 1620 tracks the waveform envelope of the amplified signal. By dynamically modulating the rail voltage of the power amplifier 1620 based on the waveform envelope, the efficiency of the power amplifier 1620 may be

significantly improved relative to a fixed rail voltage amplifier scheme. The processor 1740 may be configured for wired or wireless communication.

[0428] In certain aspects and as discussed in further detail in connection with FIGS. 28A-28B, the programmable logic device 1660, in conjunction with the processor 1740, may implement a direct digital synthesizer (DDS) control scheme to control the waveform shape, frequency and/or amplitude of drive signals output by the generator 1100. In one aspect, for example, the programmable logic device 1660 may implement a DDS control algorithm 2680 (FIG. 28A) by recalling waveform samples stored in a dynamically-updated look-up table (LUT), such as a RAM LUT which may be embedded in an FPGA. This control algorithm is particularly useful for ultrasonic applications in which an ultrasonic transducer, such as the ultrasonic transducer 1120, may be driven by a clean sinusoidal current at its resonant frequency. Because other frequencies may excite parasitic resonances, minimizing or reducing the total distortion of the motional branch current may correspondingly minimize or reduce undesirable resonance effects. Because the waveform shape of a drive signal output by the generator 1100 is impacted by various sources of distortion present in the output drive circuit (e.g., the power transformer 1560, the power amplifier 1620), voltage and current feedback data based on the drive signal may be input into an algorithm, such as an error control algorithm implemented by the processor 1740, which compensates for distortion by suitably pre-distorting or modifying the waveform samples stored in the LUT on a dynamic, ongoing basis (e.g., in real-time). In one aspect, the amount or degree of pre-distortion applied to the LUT samples may be based on the error between a computed motional branch current and a desired current waveform shape, with the error being determined on a sample-by-sample basis. In this way, the pre-distorted LUT samples, when processed through the drive circuit, may result in a motional branch drive signal having the desired waveform shape (e.g., sinusoidal) for optimally driving the ultrasonic transducer. In such aspects, the LUT waveform samples will therefore not represent the desired waveform shape of the drive signal, but rather the waveform shape that is required to ultimately produce the desired waveform shape of the motional branch drive signal when distortion effects are taken into account.

[0429] The non-isolated stage 1540 may further comprise an ADC 1780 and an ADC 1800 coupled to the output of the power transformer 1560 via respective isolation transformers 1820, 1840 for respectively sampling the voltage and current of drive signals output by the generator 1100. In certain aspects, the ADCs 1780, 1800 may be configured to sample at high speeds (e.g., 80 Msps) to enable oversampling of the drive signals. In one aspect, for example, the sampling speed of the ADCs 1780, 1800 may enable approximately 200× (depending on drive frequency) oversampling of the drive signals. In certain aspects, the sampling operations of the ADCs 1780, 1800 may be performed by a single ADC receiving input voltage and current signals via a two-way multiplexer. The use of high-speed sampling in aspects of the generator 1100 may enable, among other things, calculation of the complex current flowing through the motional branch (which may be used in certain aspects to implement DDS-based waveform shape control described above), accurate digital filtering of the sampled signals, and calculation of real power consumption with a high degree of

precision. Voltage and current feedback data output by the ADCs 1780, 1800 may be received and processed (e.g., FIFO buffering, multiplexing) by the programmable logic device 1660 and stored in data memory for subsequent retrieval by, for example, the processor 1740. As noted above, voltage and current feedback data may be used as input to an algorithm for pre-distorting or modifying LUT waveform samples on a dynamic and ongoing basis. In certain aspects, this may require each stored voltage and current feedback data pair to be indexed based on, or otherwise associated with, a corresponding LUT sample that was output by the programmable logic device 1660 when the voltage and current feedback data pair was acquired. Synchronization of the LUT samples and the voltage and current feedback data in this manner contributes to the correct timing and stability of the pre-distortion algorithm.

[0430] In certain aspects, the voltage and current feedback data may be used to control the frequency and/or amplitude (e.g., current amplitude) of the drive signals. In one aspect, for example, voltage and current feedback data may be used to determine impedance phase, e.g., the phase difference between the voltage and current drive signals. The frequency of the drive signal may then be controlled to minimize or reduce the difference between the determined impedance phase and an impedance phase setpoint (e.g., 0°), thereby minimizing or reducing the effects of harmonic distortion and correspondingly enhancing impedance phase measurement accuracy. The determination of phase impedance and a frequency control signal may be implemented in the processor 1740, for example, with the frequency control signal being supplied as input to a DDS control algorithm implemented by the programmable logic device 1660.

[0431] The impedance phase may be determined through Fourier analysis. In one aspect, the phase difference between the generator voltage $V_g(t)$ and generator current $I_g(t)$ driving signals may be determined using the Fast Fourier Transform (FFT) or the Discrete Fourier Transform (DFT) as follows:

$$V_g(t) = A_1 \cos(2\pi f_0 t + \varphi_1)$$

$$I_g(t) = A_2 \cos(2\pi f_0 t + \varphi_2)$$

$$V_g(f) = \frac{A_1}{2} (\delta(f - f_0) + \delta(f + f_0)) \exp\left(j2\pi f \frac{\varphi_1}{2\pi f_0}\right)$$

$$I_g(f) = \frac{A_2}{2} (\delta(f - f_0) + \delta(f + f_0)) \exp\left(j2\pi f \frac{\varphi_2}{2\pi f_0}\right)$$

[0432] Evaluating the Fourier Transform at the frequency of the sinusoid yields:

$$V_g(f_0) = \frac{A_1}{2} \delta(0) \exp(j\varphi_1) \arg V(f_0) = \varphi_1$$

$$I_g(f_0) = \frac{A_2}{2} \delta(0) \exp(j\varphi_2) \arg I(f_0) = \varphi_2$$

[0433] Other approaches include weighted least-squares estimation, Kalman filtering, and space-vector-based techniques. Virtually all of the processing in an FFT or DFT technique may be performed in the digital domain with the aid of the 2-channel high speed ADC 1780, 1800, for example. In one technique, the digital signal samples of the

voltage and current signals are Fourier transformed with an FFT or a DFT. The phase angle φ at any point in time can be calculated by:

$$\varphi = 2\pi ft + \varphi_0$$

[0434] where φ is the phase angle, f is the frequency, t is time, and φ_0 is the phase at $t=0$.

[0435] Another technique for determining the phase difference between the voltage $V_g(t)$ and current $I_g(t)$ signals is the zero-crossing method and produces highly accurate results. For voltage $V_g(t)$ and current $I_g(t)$ signals having the same frequency, each negative to positive zero-crossing of voltage signal $V_g(t)$ triggers the start of a pulse, while each negative to positive zero-crossing of current signal $I_g(t)$ triggers the end of the pulse. The result is a pulse train with a pulse width proportional to the phase angle between the voltage signal and the current signal. In one aspect, the pulse train may be passed through an averaging filter to yield a measure of the phase difference. Furthermore, if the positive to negative zero crossings also are used in a similar manner, and the results averaged, any effects of DC and harmonic components can be reduced. In one implementation, the analog voltage $V_g(t)$ and current $I_g(t)$ signals are converted to digital signals that are high if the analog signal is positive and low if the analog signal is negative. High accuracy phase estimates require sharp transitions between high and low. In one aspect, a Schmitt trigger along with an RC stabilization network may be employed to convert the analog signals into digital signals. In other aspects, an edge triggered RS flip-flop and ancillary circuitry may be employed. In yet another aspect, the zero-crossing technique may employ an eXclusive OR (XOR) gate.

[0436] Other techniques for determining the phase difference between the voltage and current signals include Lissajous figures and monitoring the image; methods such as the three-voltmeter method, the crossed-coil method, vector voltmeter and vector impedance methods; and using phase standard instruments, phase-locked loops, and other techniques as described in Phase Measurement, Peter O'Shea, 2000 CRC Press LLC, <<http://www.engnetbase.com>>, which is incorporated herein by reference.

[0437] In another aspect, for example, the current feedback data may be monitored in order to maintain the current amplitude of the drive signal at a current amplitude setpoint. The current amplitude setpoint may be specified directly or determined indirectly based on specified voltage amplitude and power setpoints. In certain aspects, control of the current amplitude may be implemented by control algorithm, such as, for example, a proportional-integral-derivative (PID) control algorithm, in the processor 1740. Variables controlled by the control algorithm to suitably control the current amplitude of the drive signal may include, for example, the scaling of the LUT waveform samples stored in the programmable logic device 1660 and/or the full-scale output voltage of the DAC 1680 (which supplies the input to the power amplifier 1620) via a DAC 1860.

[0438] The non-isolated stage 1540 may further comprise a processor 1900 for providing, among other things, user interface (UI) functionality. In one aspect, the processor 1900 may comprise an Atmel AT91 SAM9263 processor having an ARM 926EJ-S core, available from Atmel Corporation, San Jose, Calif., for example. Examples of UI functionality supported by the processor 1900 may include audible and visual user feedback, communication with

peripheral devices (e.g., via a Universal Serial Bus (USB) interface), communication with a foot switch 1430, communication with an input device 2150 (e.g., a touch screen display) and communication with an output device 2140 (e.g., a speaker). The processor 1900 may communicate with the processor 1740 and the programmable logic device (e.g., via a serial peripheral interface (SPI) bus). Although the processor 1900 may primarily support UI functionality, it may also coordinate with the processor 1740 to implement hazard mitigation in certain aspects. For example, the processor 1900 may be programmed to monitor various aspects of user input and/or other inputs (e.g., touch screen inputs 2150, foot switch 1430 inputs, temperature sensor inputs 2160) and may disable the drive output of the generator 1100 when an erroneous condition is detected.

[0439] In certain aspects, both the processor 1740 (FIG. 26, 27A) and the processor 1900 (FIG. 26, 27B) may determine and monitor the operating state of the generator 1100. For processor 1740, the operating state of the generator 1100 may dictate, for example, which control and/or diagnostic processes are implemented by the processor 1740. For processor 1900, the operating state of the generator 1100 may dictate, for example, which elements of a user interface (e.g., display screens, sounds) are presented to a user. The processors 1740, 1900 may independently maintain the current operating state of the generator 1100 and recognize and evaluate possible transitions out of the current operating state. The processor 1740 may function as the master in this relationship and determine when transitions between operating states are to occur. The processor 1900 may be aware of valid transitions between operating states and may confirm if a particular transition is appropriate. For example, when the processor 1740 instructs the processor 1900 to transition to a specific state, the processor 1900 may verify that the requested transition is valid. In the event that a requested transition between states is determined to be invalid by the processor 1900, the processor 1900 may cause the generator 1100 to enter a failure mode.

[0440] The non-isolated stage 1540 may further comprise a controller 1960 (FIG. 26, 27B) for monitoring input devices 2150 (e.g., a capacitive touch sensor used for turning the generator 1100 on and off, a capacitive touch screen). In certain aspects, the controller 1960 may comprise at least one processor and/or other controller device in communication with the processor 1900. In one aspect, for example, the controller 1960 may comprise a processor (e.g., a Mega168 8-bit controller available from Atmel) configured to monitor user input provided via one or more capacitive touch sensors. In one aspect, the controller 1960 may comprise a touch screen controller (e.g., a QT5480 touch screen controller available from Atmel) to control and manage the acquisition of touch data from a capacitive touch screen.

[0441] In certain aspects, when the generator 1100 is in a "power off" state, the controller 1960 may continue to receive operating power (e.g., via a line from a power supply of the generator 1100, such as the power supply 2110 (FIG. 26) discussed below). In this way, the controller 1960 may continue to monitor an input device 2150 (e.g., a capacitive touch sensor located on a front panel of the generator 1100) for turning the generator 1100 on and off. When the generator 1100 is in the "power off" state, the controller 1960 may wake the power supply (e.g., enable operation of one or more DC/DC voltage converters 2130 (FIG. 26) of the

power supply 2110) if activation of the “on/off” input device 2150 by a user is detected. The controller 1960 may therefore initiate a sequence for transitioning the generator 1100 to a “power on” state. Conversely, the controller 1960 may initiate a sequence for transitioning the generator 1100 to the “power off” state if activation of the “on/off” input device 2150 is detected when the generator 1100 is in the “power on” state. In certain aspects, for example, the controller 1960 may report activation of the “on/off” input device 2150 to the processor 1900, which in turn implements the necessary process sequence for transitioning the generator 1100 to the “power off” state. In such aspects, the controller 1960 may have no independent ability for causing the removal of power from the generator 1100 after its “power on” state has been established.

[0442] In certain aspects, the controller 1960 may cause the generator 1100 to provide audible or other sensory feedback for alerting the user that a “power on” or “power off” sequence has been initiated. Such an alert may be provided at the beginning of a “power on” or “power off” sequence and prior to the commencement of other processes associated with the sequence.

[0443] In certain aspects, the isolated stage 1520 may comprise an instrument interface circuit 1980 to, for example, provide a communication interface between a control circuit of a surgical device (e.g., a control circuit comprising handpiece switches) and components of the non-isolated stage 1540, such as, for example, the programmable logic device 1660, the processor 1740 and/or the processor 1900. The instrument interface circuit 1980 may exchange information with components of the non-isolated stage 1540 via a communication link that maintains a suitable degree of electrical isolation between the stages 1520, 1540, such as, for example, an infrared (IR)-based communication link. Power may be supplied to the instrument interface circuit 1980 using, for example, a low-dropout voltage regulator powered by an isolation transformer driven from the non-isolated stage 1540.

[0444] In one aspect, the instrument interface circuit 1980 may comprise a programmable logic device 2000 (e.g., an FPGA) in communication with a signal conditioning circuit 2020 (FIG. 26 and FIG. 27C). The signal conditioning circuit 2020 may be configured to receive a periodic signal from the programmable logic device 2000 (e.g., a 2 kHz square wave) to generate a bipolar interrogation signal having an identical frequency. The interrogation signal may be generated, for example, using a bipolar current source fed by a differential amplifier. The interrogation signal may be communicated to a surgical device control circuit (e.g., by using a conductive pair in a cable that connects the generator 1100 to the surgical device) and monitored to determine a state or configuration of the control circuit. For example, the control circuit may comprise a number of switches, resistors and/or diodes to modify one or more characteristics (e.g., amplitude, rectification) of the interrogation signal such that a state or configuration of the control circuit is uniquely discernible based on the one or more characteristics. In one aspect, for example, the signal conditioning circuit 2020 may comprise an ADC for generating samples of a voltage signal appearing across inputs of the control circuit resulting from passage of interrogation signal therethrough. The programmable logic device 2000 (or a component of the

non-isolated stage 1540) may then determine the state or configuration of the control circuit based on the ADC samples.

[0445] In one aspect, the instrument interface circuit 1980 may comprise a first data circuit interface 2040 to enable information exchange between the programmable logic device 2000 (or other element of the instrument interface circuit 1980) and a first data circuit disposed in or otherwise associated with a surgical device. In certain aspects, for example, a first data circuit 2060 may be disposed in a cable integrally attached to a surgical device handpiece, or in an adaptor for interfacing a specific surgical device type or model with the generator 1100. In certain aspects, the first data circuit may comprise a non-volatile storage device, such as an electrically erasable programmable read-only memory (EEPROM) device. In certain aspects and referring again to FIG. 26, the first data circuit interface 2040 may be implemented separately from the programmable logic device 2000 and comprise suitable circuitry (e.g., discrete logic devices, a processor) to enable communication between the programmable logic device 2000 and the first data circuit. In other aspects, the first data circuit interface 2040 may be integral with the programmable logic device 2000.

[0446] In certain aspects, the first data circuit 2060 may store information pertaining to the particular surgical device with which it is associated. Such information may include, for example, a model number, a serial number, a number of operations in which the surgical device has been used, and/or any other type of information. This information may be read by the instrument interface circuit 1980 (e.g., by the programmable logic device 2000), transferred to a component of the non-isolated stage 1540 (e.g., to programmable logic device 1660, processor 1740 and/or processor 1900) for presentation to a user via an output device 2140 and/or for controlling a function or operation of the generator 1100. Additionally, any type of information may be communicated to first data circuit 2060 for storage therein via the first data circuit interface 2040 (e.g., using the programmable logic device 2000). Such information may comprise, for example, an updated number of operations in which the surgical device has been used and/or dates and/or times of its usage.

[0447] As discussed previously, a surgical instrument may be detachable from a handpiece (e.g., instrument 1106 may be detachable from handpiece 1107) to promote instrument interchangeability and/or disposability. In such cases, known generators may be limited in their ability to recognize particular instrument configurations being used and to optimize control and diagnostic processes accordingly. The addition of readable data circuits to surgical device instruments to address this issue is problematic from a compatibility standpoint, however. For example, it may be impractical to design a surgical device to maintain backward compatibility with generators that lack the requisite data reading functionality due to, for example, differing signal schemes, design complexity and cost. Other aspects of instruments address these concerns by using data circuits that may be implemented in existing surgical instruments economically and with minimal design changes to preserve compatibility of the surgical devices with current generator platforms.

[0448] Additionally, aspects of the generator 1100 may enable communication with instrument-based data circuits. For example, the generator 1100 may be configured to

communicate with a second data circuit (e.g., a data circuit) contained in an instrument (e.g., instrument **1104**, **1106** or **1108**) of a surgical device. The instrument interface circuit **1980** may comprise a second data circuit interface **2100** to enable this communication. In one aspect, the second data circuit interface **2100** may comprise a tri-state digital interface, although other interfaces may also be used. In certain aspects, the second data circuit may generally be any circuit for transmitting and/or receiving data. In one aspect, for example, the second data circuit may store information pertaining to the particular surgical instrument with which it is associated. Such information may include, for example, a model number, a serial number, a number of operations in which the surgical instrument has been used, and/or any other type of information. Additionally or alternatively, any type of information may be communicated to the second data circuit for storage therein via the second data circuit interface **2100** (e.g., using the programmable logic device **2000**). Such information may comprise, for example, an updated number of operations in which the instrument has been used and/or dates and/or times of its usage. In certain aspects, the second data circuit may transmit data acquired by one or more sensors (e.g., an instrument-based temperature sensor). In certain aspects, the second data circuit may receive data from the generator **1100** and provide an indication to a user (e.g., an LED indication or other visible indication) based on the received data.

[0449] In certain aspects, the second data circuit and the second data circuit interface **2100** may be configured such that communication between the programmable logic device **2000** and the second data circuit can be effected without the need to provide additional conductors for this purpose (e.g., dedicated conductors of a cable connecting a handpiece to the generator **1100**). In one aspect, for example, information may be communicated to and from the second data circuit using a one-wire bus communication scheme implemented on existing cabling, such as one of the conductors used to transmit interrogation signals from the signal conditioning circuit **2020** to a control circuit in a handpiece. In this way, design changes or modifications to the surgical device that might otherwise be necessary are minimized or reduced. Moreover, because different types of communications can be implemented over a common physical channel (either with or without frequency-band separation), the presence of a second data circuit may be “invisible” to generators that do not have the requisite data reading functionality, thus enabling backward compatibility of the surgical device instrument.

[0450] In certain aspects, the isolated stage **1520** may comprise at least one blocking capacitor **2960-1** (FIG. 27C) connected to the drive signal output **1600b** to prevent passage of DC current to a patient. A single blocking capacitor may be required to comply with medical regulations or standards, for example. While failure in single-capacitor designs is relatively uncommon, such failure may nonetheless have negative consequences. In one aspect, a second blocking capacitor **2960-2** may be provided in series with the blocking capacitor **2960-1**, with current leakage from a point between the blocking capacitors **2960-1**, **2960-2** being monitored by, for example, an ADC **2980** for sampling a voltage induced by leakage current. The samples may be received by the programmable logic device **2000**, for example. Based on changes in the leakage current (as indicated by the voltage samples in the aspect of FIG. 26),

the generator **1100** may determine when at least one of the blocking capacitors **2960-1**, **2960-2** has failed. Accordingly, the aspect of FIG. 26 may provide a benefit over single-capacitor designs having a single point of failure.

[0451] In certain aspects, the non-isolated stage **1540** may comprise a power supply **2110** for outputting DC power at a suitable voltage and current. The power supply may comprise, for example, a 400 W power supply for outputting a 48 VDC system voltage. As discussed above, the power supply **2110** may further comprise one or more DC/DC voltage converters **2130** for receiving the output of the power supply to generate DC outputs at the voltages and currents required by the various components of the generator **1100**. As discussed above in connection with the controller **1960**, one or more of the DC/DC voltage converters **2130** may receive an input from the controller **1960** when activation of the “on/off” input device **2150** by a user is detected by the controller **1960** to enable operation of, or wake, the DC/DC voltage converters **2130**.

[0452] FIGS. 28A-28B illustrate certain functional and structural aspects of one aspect of the generator **1100**. Feedback indicating current and voltage output from the secondary winding **1580** of the power transformer **1560** is received by the ADCs **1780**, **1800**, respectively. As shown, the ADCs **1780**, **1800** may be implemented as a 2-channel ADC and may sample the feedback signals at a high speed (e.g., 80 Msps) to enable oversampling (e.g., approximately 200× oversampling) of the drive signals. The current and voltage feedback signals may be suitably conditioned in the analog domain (e.g., amplified, filtered) prior to processing by the ADCs **1780**, **1800**. Current and voltage feedback samples from the ADCs **1780**, **1800** may be individually buffered and subsequently multiplexed or interleaved into a single data stream within block **2120** of the programmable logic device **1660**. In the aspect of FIGS. 28A-28B, the programmable logic device **1660** comprises an FPGA.

[0453] The multiplexed current and voltage feedback samples may be received by a parallel data acquisition port (PDAP) implemented within block **2144** of the processor **1740**. The PDAP may comprise a packing unit for implementing any of a number of methodologies for correlating the multiplexed feedback samples with a memory address. In one aspect, for example, feedback samples corresponding to a particular LUT sample output by the programmable logic device **1660** may be stored at one or more memory addresses that are correlated or indexed with the LUT address of the LUT sample. In another aspect, feedback samples corresponding to a particular LUT sample output by the programmable logic device **1660** may be stored, along with the LUT address of the LUT sample, at a common memory location. In any event, the feedback samples may be stored such that the address of the LUT sample from which a particular set of feedback samples originated may be subsequently ascertained. As discussed above, synchronization of the LUT sample addresses and the feedback samples in this way contributes to the correct timing and stability of the pre-distortion algorithm. A direct memory access (DMA) controller implemented at block **2166** of the processor **1740** may store the feedback samples (and any LUT sample address data, where applicable) at a designated memory location **2180** of the processor **1740** (e.g., internal RAM).

[0454] Block **2200** of the processor **1740** may implement a pre-distortion algorithm for pre-distorting or modifying the

LUT samples stored in the programmable logic device 1660 on a dynamic, ongoing basis. As discussed above, pre-distortion of the LUT samples may compensate for various sources of distortion present in the output drive circuit of the generator 1100. The pre-distorted LUT samples, when processed through the drive circuit, will therefore result in a drive signal having the desired waveform shape (e.g., sinusoidal) for optimally driving the ultrasonic transducer.

[0455] At block 2220 of the pre-distortion algorithm, the current through the motional branch of the ultrasonic transducer is determined. The motional branch current may be determined using Kirchhoff's Current Law based on, for example, the current and voltage feedback samples stored at memory location 2180 (which, when suitably scaled, may be representative of I_g and V_g in the model of FIG. 25 discussed above), a value of the ultrasonic transducer static capacitance C_0 (measured or known a priori) and a known value of the drive frequency. A motional branch current sample for each set of stored current and voltage feedback samples associated with a LUT sample may be determined.

[0456] At block 2240 of the pre-distortion algorithm, each motional branch current sample determined at block 2220 is compared to a sample of a desired current waveform shape to determine a difference, or sample amplitude error, between the compared samples. For this determination, the sample of the desired current waveform shape may be supplied, for example, from a waveform shape LUT 2260 containing amplitude samples for one cycle of a desired current waveform shape. The particular sample of the desired current waveform shape from the LUT 2260 used for the comparison may be dictated by the LUT sample address associated with the motional branch current sample used in the comparison. Accordingly, the input of the motional branch current to block 2240 may be synchronized with the input of its associated LUT sample address to block 2240. The LUT samples stored in the programmable logic device 1660 and the LUT samples stored in the waveform shape LUT 2260 may therefore be equal in number. In certain aspects, the desired current waveform shape represented by the LUT samples stored in the waveform shape LUT 2260 may be a fundamental sine wave. Other waveform shapes may be desirable. For example, it is contemplated that a fundamental sine wave for driving main longitudinal motion of an ultrasonic transducer superimposed with one or more other drive signals at other frequencies, such as a third order harmonic for driving at least two mechanical resonances for beneficial vibrations of transverse or other modes, could be used.

[0457] Each value of the sample amplitude error determined at block 2240 may be transmitted to the LUT of the programmable logic device 1660 (shown at block 2280 in FIG. 28A) along with an indication of its associated LUT address. Based on the value of the sample amplitude error and its associated address (and, optionally, values of sample amplitude error for the same LUT address previously received), the LUT 2280 (or other control block of the programmable logic device 1660) may pre-distort or modify the value of the LUT sample stored at the LUT address such that the sample amplitude error is reduced or minimized. It will be appreciated that such pre-distortion or modification of each LUT sample in an iterative manner across the entire range of LUT addresses will cause the waveform shape of the generator's output current to match or conform to the

desired current waveform shape represented by the samples of the waveform shape LUT 2260.

[0458] Current and voltage amplitude measurements, power measurements and impedance measurements may be determined at block 2300 of the processor 1740 based on the current and voltage feedback samples stored at memory location 2180. Prior to the determination of these quantities, the feedback samples may be suitably scaled and, in certain aspects, processed through a suitable filter 2320 to remove noise resulting from, for example, the data acquisition process and induced harmonic components. The filtered voltage and current samples may therefore substantially represent the fundamental frequency of the generator's drive output signal. In certain aspects, the filter 2320 may be a finite impulse response (FIR) filter applied in the frequency domain. Such aspects may use the Fast Fourier Transform (FFT) of the output drive signal current and voltage signals. In certain aspects, the resulting frequency spectrum may be used to provide additional generator functionality. In one aspect, for example, the ratio of the second and/or third order harmonic component relative to the fundamental frequency component may be used as a diagnostic indicator.

[0459] At block 2340 (FIG. 28B), a root mean square (RMS) calculation may be applied to a sample size of the current feedback samples representing an integral number of cycles of the drive signal to generate a measurement I_{rms} representing the drive signal output current.

[0460] At block 2360, a root mean square (RMS) calculation may be applied to a sample size of the voltage feedback samples representing an integral number of cycles of the drive signal to determine a measurement V_{rms} representing the drive signal output voltage.

[0461] At block 2380, the current and voltage feedback samples may be multiplied point by point, and a mean calculation is applied to samples representing an integral number of cycles of the drive signal to determine a measurement P' of the generator's real output power.

[0462] At block 2400, measurement P_a of the generator's apparent output power may be determined as the product $V_{rms} \cdot I_{rms}$.

[0463] At block 2420, measurement Z_m of the load impedance magnitude may be determined as the quotient V_{rms}/I_{rms} .

[0464] In certain aspects, the quantities I_{rms} , V_{rms} , P_r , P_a and Z_m determined at blocks 2340, 2360, 2380, 2400 and 2420 may be used by the generator 1100 to implement any of a number of control and/or diagnostic processes. In certain aspects, any of these quantities may be communicated to a user via, for example, an output device 2140 integral with the generator 1100 or an output device 2140 connected to the generator 1100 through a suitable communication interface (e.g., a USB interface). Various diagnostic processes may include, without limitation, handpiece integrity, instrument integrity, instrument attachment integrity, instrument overload, approaching instrument overload, frequency lock failure, over-voltage condition, over-current condition, over-power condition, voltage sense failure, current sense failure, audio indication failure, visual indication failure, short circuit condition, power delivery failure, or blocking capacitor failure, for example.

[0465] Block 2440 of the processor 1740 may implement a phase control algorithm for determining and controlling the impedance phase of an electrical load (e.g., the ultrasonic transducer) driven by the generator 1100. As discussed

above, by controlling the frequency of the drive signal to minimize or reduce the difference between the determined impedance phase and an impedance phase setpoint (e.g., 0°), the effects of harmonic distortion may be minimized or reduced, and the accuracy of the phase measurement increased.

[0466] The phase control algorithm receives as input the current and voltage feedback samples stored in the memory location **2180**. Prior to their use in the phase control algorithm, the feedback samples may be suitably scaled and, in certain aspects, processed through a suitable filter **2460** (which may be identical to filter **2320**) to remove noise resulting from the data acquisition process and induced harmonic components, for example. The filtered voltage and current samples may therefore substantially represent the fundamental frequency of the generator's drive output signal.

[0467] At block **2480** of the phase control algorithm, the current through the motional branch of the ultrasonic transducer is determined. This determination may be identical to that described above in connection with block **2220** of the pre-distortion algorithm. The output of block **2480** may thus be, for each set of stored current and voltage feedback samples associated with a LUT sample, a motional branch current sample.

[0468] At block **2500** of the phase control algorithm, impedance phase is determined based on the synchronized input of motional branch current samples determined at block **2480** and corresponding voltage feedback samples. In certain aspects, the impedance phase is determined as the average of the impedance phase measured at the rising edge of the waveforms and the impedance phase measured at the falling edge of the waveforms.

[0469] At block **2520** of the of the phase control algorithm, the value of the impedance phase determined at block **2220** is compared to phase setpoint **2540** to determine a difference, or phase error, between the compared values.

[0470] At block **2560** (FIG. **28A**) of the phase control algorithm, based on a value of phase error determined at block **2520** and the impedance magnitude determined at block **2420**, a frequency output for controlling the frequency of the drive signal is determined. The value of the frequency output may be continuously adjusted by the block **2560** and transferred to a DDS control block **2680** (discussed below) in order to maintain the impedance phase determined at block **2500** at the phase setpoint (e.g., zero phase error). In certain aspects, the impedance phase may be regulated to a 0° phase setpoint. In this way, any harmonic distortion will be centered about the crest of the voltage waveform, enhancing the accuracy of phase impedance determination.

[0471] Block **2580** of the processor **1740** may implement an algorithm for modulating the current amplitude of the drive signal in order to control the drive signal current, voltage and power in accordance with user specified setpoints, or in accordance with requirements specified by other processes or algorithms implemented by the generator **1100**. Control of these quantities may be realized, for example, by scaling the LUT samples in the LUT **2280** and/or by adjusting the full-scale output voltage of the DAC **1680** (which supplies the input to the power amplifier **1620**) via a DAC **1860**. Block **2600** (which may be implemented as a PID controller in certain aspects) may receive, as input, current feedback samples (which may be suitably scaled and filtered) from the memory location **2180**. The current feed-

back samples may be compared to a "current demand" I_d value dictated by the controlled variable (e.g., current, voltage or power) to determine if the drive signal is supplying the necessary current. In aspects in which drive signal current is the control variable, the current demand I_d may be specified directly by a current setpoint **2620A** (I_{sp}). For example, an RMS value of the current feedback data (determined as in block **2340**) may be compared to user-specified RMS current setpoint I_{sp} to determine the appropriate controller action. If, for example, the current feedback data indicates an RMS value less than the current setpoint I_{sp} , LUT scaling and/or the full-scale output voltage of the DAC **1680** may be adjusted by the block **2600** such that the drive signal current is increased. Conversely, block **2600** may adjust LUT scaling and/or the full-scale output voltage of the DAC **1680** to decrease the drive signal current when the current feedback data indicates an RMS value greater than the current setpoint I_{sp} .

[0472] In aspects in which the drive signal voltage is the control variable, the current demand I_d may be specified indirectly, for example, based on the current required to maintain a desired voltage setpoint **2620B** (V_{sp}) given the load impedance magnitude Z_m measured at block **2420** (e.g. $I_d=V_{sp}/Z_m$). Similarly, in aspects in which drive signal power is the control variable, the current demand I_d may be specified indirectly, for example, based on the current required to maintain a desired power setpoint **2620C** (P_{sp}) given the voltage V_{rms} measured at blocks **2360** (e.g. $I_d=P_{sp}/V_{rms}$).

[0473] Block **2680** (FIG. **28A**) may implement a DDS control algorithm for controlling the drive signal by recalling LUT samples stored in the LUT **2280**. In certain aspects, the DDS control algorithm may be a numerically-controlled oscillator (NCO) algorithm for generating samples of a waveform at a fixed clock rate using a point (memory location)-skipping technique. The NCO algorithm may implement a phase accumulator, or frequency-to-phase converter, that functions as an address pointer for recalling LUT samples from the LUT **2280**. In one aspect, the phase accumulator may be a D step size, modulo N phase accumulator, where D is a positive integer representing a frequency control value, and N is the number of LUT samples in the LUT **2280**. A frequency control value of $D=1$, for example, may cause the phase accumulator to sequentially point to every address of the LUT **2280**, resulting in a waveform output replicating the waveform stored in the LUT **2280**. When $D>1$, the phase accumulator may skip addresses in the LUT **2280**, resulting in a waveform output having a higher frequency. Accordingly, the frequency of the waveform generated by the DDS control algorithm may therefore be controlled by suitably varying the frequency control value. In certain aspects, the frequency control value may be determined based on the output of the phase control algorithm implemented at block **2440**. The output of block **2680** may supply the input of DAC **1680**, which in turn supplies a corresponding analog signal to an input of the power amplifier **1620**.

[0474] Block **2700** of the processor **1740** may implement a switch-mode converter control algorithm for dynamically modulating the rail voltage of the power amplifier **1620** based on the waveform envelope of the signal being amplified, thereby improving the efficiency of the power amplifier **1620**. In certain aspects, characteristics of the waveform envelope may be determined by monitoring one or more

signals contained in the power amplifier 1620. In one aspect, for example, characteristics of the waveform envelope may be determined by monitoring the minima of a drain voltage (e.g., a MOSFET drain voltage) that is modulated in accordance with the envelope of the amplified signal. A minima voltage signal may be generated, for example, by a voltage minima detector coupled to the drain voltage. The minima voltage signal may be sampled by ADC 1760, with the output minima voltage samples being received at block 2720 of the switch-mode converter control algorithm. Based on the values of the minima voltage samples, block 2740 may control a PWM signal output by a PWM generator 2760, which, in turn, controls the rail voltage supplied to the power amplifier 1620 by the switch-mode regulator 1700. In certain aspects, as long as the values of the minima voltage samples are less than a minima target 2780 input into block 2720, the rail voltage may be modulated in accordance with the waveform envelope as characterized by the minima voltage samples. When the minima voltage samples indicate low envelope power levels, for example, block 2740 may cause a low rail voltage to be supplied to the power amplifier 1620, with the full rail voltage being supplied only when the minima voltage samples indicate maximum envelope power levels. When the minima voltage samples fall below the minima target 2780, block 2740 may cause the rail voltage to be maintained at a minimum value suitable for ensuring proper operation of the power amplifier 1620.

[0475] FIG. 29 is a schematic diagram of one aspect of an electrical circuit 2900, suitable for driving an ultrasonic transducer, such as ultrasonic transducer 1120, in accordance with at least one aspect of the present disclosure. The electrical circuit 2900 comprises an analog multiplexer 2980. The analog multiplexer 2980 multiplexes various signals from the upstream channels SCL-A, SDA-A such as ultrasonic, battery, and power control circuit. A current sensor 2982 is coupled in series with the return or ground leg of the power supply circuit to measure the current supplied by the power supply. A field effect transistor (FET) temperature sensor 2984 provides the ambient temperature. A pulse width modulation (PWM) watchdog timer 2988 automatically generates a system reset if the main program neglects to periodically service it. It is provided to automatically reset the electrical circuit 2900 when it hangs or freezes because of a software or hardware fault. It will be appreciated that the electrical circuit 2900 may be configured as an RF driver circuit for driving the ultrasonic transducer or for driving RF electrodes such as the electrical circuit 3600 shown in FIG. 36, for example. Accordingly, with reference now back to FIG. 29, the electrical circuit 2900 can be used to drive both ultrasonic transducers and RF electrodes interchangeably. If driven simultaneously, filter circuits may be provided in the corresponding first stage circuits 3404 (FIG. 34) to select either the ultrasonic waveform or the RF waveform. Such filtering techniques are described in commonly owned U.S. Pat. Pub. No. US-2017-0086910-A1, titled TECHNIQUES FOR CIRCUIT TOPOLOGIES FOR COMBINED GENERATOR, which is herein incorporated by reference in its entirety.

[0476] A drive circuit 2986 provides left and right ultrasonic energy outputs. A digital signal that represents the signal waveform is provided to the SCL-A, SDA-A inputs of the analog multiplexer 2980 from a control circuit, such as the control circuit 3200 (FIG. 32). A digital-to-analog converter 2990 (DAC) converts the digital input to an analog

output to drive a PWM circuit 2992 coupled to an oscillator 2994. The PWM circuit 2992 provides a first signal to a first gate drive circuit 2996a coupled to a first transistor output stage 2998a to drive a first Ultrasonic (LEFT) energy output. The PWM circuit 2992 also provides a second signal to a second gate drive circuit 2996b coupled to a second transistor output stage 2998b to drive a second Ultrasonic (RIGHT) energy output. A voltage sensor 2999 is coupled between the Ultrasonic LEFT/RIGHT output terminals to measure the output voltage. The drive circuit 2986, the first and second drive circuits 2996a, 2996b, and the first and second transistor output stages 2998a, 2998b define a first stage amplifier circuit. In operation, the control circuit 3200 (FIG. 32) generates a digital waveform 4300 (FIG. 43) employing circuits such as direct digital synthesis (DDS) circuits 4100, 4200 (FIGS. 41 and 42). The DAC 2990 receives the digital waveform 4300 and converts it into an analog waveform, which is received and amplified by the first stage amplifier circuit.

[0477] FIG. 30 is a schematic diagram of the transformer 3000 coupled to the electrical circuit 2900 shown in FIG. 29, in accordance with at least one aspect of the present disclosure. The Ultrasonic LEFT/RIGHT input terminals (primary winding) of the transformer 3000 are electrically coupled to the Ultrasonic LEFT/RIGHT output terminals of the electrical circuit 2900. The secondary winding of the transformer 3000 are coupled to the positive and negative electrodes 3074a, 3074b. The positive and negative electrodes 3074a, 3074b of the transformer 3000 are coupled to the positive terminal (Stack 1) and the negative terminal (Stack 2) of an ultrasonic transducer. In one aspect, the transformer 3000 has a turns-ratio of $n_1:n_2$ of 1:50.

[0478] FIG. 31 is a schematic diagram of the transformer 3000 shown in FIG. 30 coupled to a test circuit 3165, in accordance with at least one aspect of the present disclosure. The test circuit 3165 is coupled to the positive and negative electrodes 3074a, 3074b. A switch 3167 is placed in series with an inductor/capacitor/resistor (LCR) load that simulates the load of an ultrasonic transducer.

[0479] FIG. 32 is a schematic diagram of a control circuit 3200, such as control circuit 3212, in accordance with at least one aspect of the present disclosure. The control circuit 3200 is located within a housing of the battery assembly. The battery assembly is the energy source for a variety of local power supplies 3215. The control circuit comprises a main processor 3214 coupled via an interface master 3218 to various downstream circuits by way of outputs SCL-A and SDA-A, SCL-B and SDA-B, SCL-C and SDA-C, for example. In one aspect, the interface master 3218 is a general purpose serial interface such as an I²C serial interface. The main processor 3214 also is configured to drive switches 3224 through general purposes input/output (GPIO) 3220, a display 3226 (e.g., and LCD display), and various indicators 3228 through GPIO 3222. A watchdog processor 3216 is provided to control the main processor 3214. A switch 3230 is provided in series with a battery 3211 to activate the control circuit 3212 upon insertion of the battery assembly into a handle assembly of a surgical instrument.

[0480] In one aspect, the main processor 3214 is coupled to the electrical circuit 2900 (FIG. 29) by way of output terminals SCL-A, SDA-A. The main processor 3214 comprises a memory for storing tables of digitized drive signals or waveforms that are transmitted to the electrical circuit

2900 for driving the ultrasonic transducer **1120**, for example. In other aspects, the main processor **3214** may generate a digital waveform and transmit it to the electrical circuit **2900** or may store the digital waveform for later transmission to the electrical circuit **2900**. The main processor **3214** also may provide RF drive by way of output terminals SCL-B, SDA-B and various sensors (e.g., Hall-effect sensors, magneto-rheological fluid (MRF) sensors, etc.) by way of output terminals SCL-C, SDA-C. In one aspect, the main processor **3214** is configured to sense the presence of ultrasonic drive circuitry and/or RF drive circuitry to enable appropriate software and user interface functionality.

[**0481**] In one aspect, the main processor **3214** may be an LM 4F230H5QR, available from Texas Instruments, for example. In at least one example, the Texas Instruments LM4F230H5QR is an ARM Cortex-M4F Processor Core comprising on-chip memory of 256 KB single-cycle flash memory, or other non-volatile memory, up to 40 MHz, a prefetch buffer to improve performance above 40 MHz, a 32 KB single-cycle serial random access memory (SRAM), internal read-only memory (ROM) loaded with StellarisWare® software, 2 KB electrically erasable programmable read-only memory (EEPROM), one or more pulse width modulation (PWM) modules, one or more quadrature encoder inputs (QED analog, one or more 12-bit Analog-to-Digital Converters (ADC) with 12 analog input channels, among other features that are readily available from the product datasheet. Other processors may be readily substituted and, accordingly, the present disclosure should not be limited in this context.

[**0482**] FIG. 33 shows a simplified block circuit diagram illustrating another electrical circuit **3300** contained within a modular ultrasonic surgical instrument **3334**, in accordance with at least one aspect of the present disclosure. The electrical circuit **3300** includes a processor **3302**, a clock **3330**, a memory **3326**, a power supply **3304** (e.g., a battery), a switch **3306**, such as a metal-oxide semiconductor field effect transistor (MOSFET) power switch, a drive circuit **3308** (PLL), a transformer **3310**, a signal smoothing circuit **3312** (also referred to as a matching circuit and can be, for example, a tank circuit), a sensing circuit **3314**, a transducer **1120**, and a shaft assembly (e.g. shaft assembly **1126**, **1129**) comprising an ultrasonic transmission waveguide that terminates at an ultrasonic blade (e.g. ultrasonic blade **1128**, **1149**) which may be referred to herein simply as the waveguide.

[**0483**] One feature of the present disclosure that severs dependency on high voltage (120 VAC) input power (a characteristic of general ultrasonic cutting devices) is the utilization of low-voltage switching throughout the wave-forming process and the amplification of the driving signal only directly before the transformer stage. For this reason, in one aspect of the present disclosure, power is derived from only a battery, or a group of batteries, small enough to fit either within a handle assembly. State-of-the-art battery technology provides powerful batteries of a few centimeters in height and width and a few millimeters in depth. By combining the features of the present disclosure to provide a self-contained and self-powered ultrasonic device, a reduction in manufacturing cost may be achieved.

[**0484**] The output of the power supply **3304** is fed to and powers the processor **3302**. The processor **3302** receives and outputs signals and, as will be described below, functions according to custom logic or in accordance with computer

programs that are executed by the processor **3302**. As discussed above, the electrical circuit **3300** can also include a memory **3326**, preferably, random access memory (RAM), that stores computer-readable instructions and data.

[**0485**] The output of the power supply **3304** also is directed to the switch **3306** having a duty cycle controlled by the processor **3302**. By controlling the on-time for the switch **3306**, the processor **3302** is able to dictate the total amount of power that is ultimately delivered to the transducer **1120**. In one aspect, the switch **3306** is a MOSFET, although other switches and switching configurations are adaptable as well. The output of the switch **3306** is fed to a drive circuit **3308** that contains, for example, a phase detecting phase-locked loop (PLL) and/or a low-pass filter and/or a voltage-controlled oscillator. The output of the switch **3306** is sampled by the processor **3302** to determine the voltage and current of the output signal (V_{IN} and I_{IN} , respectively). These values are used in a feedback architecture to adjust the pulse width modulation of the switch **3306**. For instance, the duty cycle of the switch **3306** can vary from about 20% to about 80%, depending on the desired and actual output from the switch **3306**.

[**0486**] The drive circuit **3308**, which receives the signal from the switch **3306**, includes an oscillatory circuit that turns the output of the switch **3306** into an electrical signal having an ultrasonic frequency, e.g., 55 kHz (VCO). As explained above, a smoothed-out version of this ultrasonic waveform is ultimately fed to the ultrasonic transducer **1120** to produce a resonant sine wave along an ultrasonic transmission waveguide.

[**0487**] At the output of the drive circuit **3308** is a transformer **3310** that is able to step up the low voltage signal(s) to a higher voltage. It is noted that upstream switching, prior to the transformer **3310**, is performed at low (e.g., battery driven) voltages, something that, to date, has not been possible for ultrasonic cutting and cautery devices. This is at least partially due to the fact that the device advantageously uses low on-resistance MOSFET switching devices. Low on-resistance MOSFET switches are advantageous, as they produce lower switching losses and less heat than a traditional MOSFET device and allow higher current to pass through. Therefore, the switching stage (pre-transformer) can be characterized as low voltage/high current. To ensure the lower on-resistance of the amplifier MOSFET(s), the MOSFET(s) are run, for example, at 10 V. In such a case, a separate 10 VDC power supply can be used to feed the MOSFET gate, which ensures that the MOSFET is fully on and a reasonably low on resistance is achieved. In one aspect of the present disclosure, the transformer **3310** steps up the battery voltage to 120 V root-mean-square (RMS). Transformers are known in the art and are, therefore, not explained here in detail.

[**0488**] In the circuit configurations described, circuit component degradation can negatively impact the circuit performance of the circuit. One factor that directly affects component performance is heat. Known circuits generally monitor switching temperatures (e.g., MOSFET temperatures). However, because of the technological advancements in MOSFET designs, and the corresponding reduction in size, MOSFET temperatures are no longer a valid indicator of circuit loads and heat. For this reason, in accordance with at least one aspect of the present disclosure, the sensing circuit **3314** senses the temperature of the transformer **3310**. This temperature sensing is advantageous as the transformer

3310 is run at or very close to its maximum temperature during use of the device. Additional temperature will cause the core material, e.g., the ferrite, to break down and permanent damage can occur. The present disclosure can respond to a maximum temperature of the transformer **3310** by, for example, reducing the driving power in the transformer **3310**, signaling the user, turning the power off, pulsing the power, or other appropriate responses.

[**0489**] In one aspect of the present disclosure, the processor **3302** is communicatively coupled to the end effector (e.g. **1122**, **1125**), which is used to place material in physical contact with the ultrasonic blade (e.g. **1128**, **1149**). Sensors are provided that measure, at the end effector, a clamping force value (existing within a known range) and, based upon the received clamping force value, the processor **3302** varies the motional voltage V_M . Because high force values combined with a set motional rate can result in high blade temperatures, a temperature sensor **3332** can be communicatively coupled to the processor **3302**, where the processor **3302** is operable to receive and interpret a signal indicating a current temperature of the blade from the temperature sensor **3336** and to determine a target frequency of blade movement based upon the received temperature. In another aspect, force sensors such as strain gages or pressure sensors may be coupled to the trigger (e.g. **1143**, **1147**) to measure the force applied to the trigger by the user. In another aspect, force sensors such as strain gages or pressure sensors may be coupled to a switch button such that displacement intensity corresponds to the force applied by the user to the switch button.

[**0490**] In accordance with at least one aspect of the present disclosure, the PLL portion of the drive circuit **3308**, which is coupled to the processor **3302**, is able to determine a frequency of waveguide movement and communicate that frequency to the processor **3302**. The processor **3302** stores this frequency value in the memory **3326** when the device is turned off. By reading the clock **3330**, the processor **3302** is able to determine an elapsed time after the device is shut off and retrieve the last frequency of waveguide movement if the elapsed time is less than a predetermined value. The device can then start up at the last frequency, which, presumably, is the optimum frequency for the current load.

[**0491**] Modular Battery Powered Handheld Surgical Instrument with Multistage Generator Circuits

[**0492**] In another aspect, the present disclosure provides a modular battery powered handheld surgical instrument with multistage generator circuits. Disclosed is a surgical instrument that includes a battery assembly, a handle assembly, and a shaft assembly where the battery assembly and the shaft assembly are configured to mechanically and electrically connect to the handle assembly. The battery assembly includes a control circuit configured to generate a digital waveform. The handle assembly includes a first stage circuit configured to receive the digital waveform, convert the digital waveform into an analog waveform, and amplify the analog waveform. The shaft assembly includes a second stage circuit coupled to the first stage circuit to receive, amplify, and apply the analog waveform to a load.

[**0493**] In one aspect, the present disclosure provides a surgical instrument, comprising: a battery assembly, comprising a control circuit comprising a battery, a memory coupled to the battery, and a processor coupled to the memory and the battery, wherein the processor is configured to generate a digital waveform; a handle assembly compris-

ing a first stage circuit coupled to the processor, the first stage circuit comprising a digital-to-analog (DAC) converter and a first stage amplifier circuit, wherein the DAC is configured to receive the digital waveform and convert the digital waveform into an analog waveform, wherein the first stage amplifier circuit is configured to receive and amplify the analog waveform; and a shaft assembly comprising a second stage circuit coupled to the first stage amplifier circuit to receive the analog waveform, amplify the analog waveform, and apply the analog waveform to a load; wherein the battery assembly and the shaft assembly are configured to mechanically and electrically connect to the handle assembly.

[**0494**] The load may comprise any one of an ultrasonic transducer, an electrode, or a sensor, or any combinations thereof. The first stage circuit may comprise a first stage ultrasonic drive circuit and a first stage high-frequency current drive circuit. The control circuit may be configured to drive the first stage ultrasonic drive circuit and the first stage high-frequency current drive circuit independently or simultaneously. The first stage ultrasonic drive circuit may be configured to couple to a second stage ultrasonic drive circuit. The second stage ultrasonic drive circuit may be configured to couple to an ultrasonic transducer. The first stage high-frequency current drive circuit may be configured to couple to a second stage high-frequency drive circuit. The second stage high-frequency drive circuit may be configured to couple to an electrode.

[**0495**] The first stage circuit may comprise a first stage sensor drive circuit. The first stage sensor drive circuit may be configured to a second stage sensor drive circuit. The second stage sensor drive circuit may be configured to couple to a sensor.

[**0496**] In another aspect, the present disclosure provides a surgical instrument, comprising: a battery assembly, comprising a control circuit comprising a battery, a memory coupled to the battery, and a processor coupled to the memory and the battery, wherein the processor is configured to generate a digital waveform; a handle assembly comprising a common first stage circuit coupled to the processor, the common first stage circuit comprising a digital-to-analog (DAC) converter and a common first stage amplifier circuit, wherein the DAC is configured to receive the digital waveform and convert the digital waveform into an analog waveform, wherein the common first stage amplifier circuit is configured to receive and amplify the analog waveform; and a shaft assembly comprising a second stage circuit coupled to the common first stage amplifier circuit to receive the analog waveform, amplify the analog waveform, and apply the analog waveform to a load; wherein the battery assembly and the shaft assembly are configured to mechanically and electrically connect to the handle assembly.

[**0497**] The load may comprise any one of an ultrasonic transducer, an electrode, or a sensor, or any combinations thereof. The common first stage circuit may be configured to drive ultrasonic, high-frequency current, or sensor circuits. The common first stage drive circuit may be configured to couple to a second stage ultrasonic drive circuit, a second stage high-frequency drive circuit, or a second stage sensor drive circuit. The second stage ultrasonic drive circuit may be configured to couple to an ultrasonic transducer, the second stage high-frequency drive circuit is configured to couple to an electrode, and the second stage sensor drive circuit is configured to couple to a sensor.

[0498] In another aspect, the present disclosure provides a surgical instrument, comprising a control circuit comprising a memory coupled to a processor, wherein the processor is configured to generate a digital waveform; a handle assembly comprising a common first stage circuit coupled to the processor, the common first stage circuit configured to receive the digital waveform, convert the digital waveform into an analog waveform, and amplify the analog waveform; and a shaft assembly comprising a second stage circuit coupled to the common first stage circuit to receive and amplify the analog waveform; wherein the shaft assembly is configured to mechanically and electrically connect to the handle assembly.

[0499] The common first stage circuit may be configured to drive ultrasonic, high-frequency current, or sensor circuits. The common first stage drive circuit may be configured to couple to a second stage ultrasonic drive circuit, a second stage high-frequency drive circuit, or a second stage sensor drive circuit. The second stage ultrasonic drive circuit may be configured to couple to an ultrasonic transducer, the second stage high-frequency drive circuit is configured to couple to an electrode, and the second stage sensor drive circuit is configured to couple to a sensor.

[0500] FIG. 34 illustrates a generator circuit 3400 partitioned into a first stage circuit 3404 and a second stage circuit 3406, in accordance with at least one aspect of the present disclosure. In one aspect, the surgical instruments of surgical system 1000 described herein may comprise a generator circuit 3400 partitioned into multiple stages. For example, surgical instruments of surgical system 1000 may comprise the generator circuit 3400 partitioned into at least two circuits: the first stage circuit 3404 and the second stage circuit 3406 of amplification enabling operation of RF energy only, ultrasonic energy only, and/or a combination of RF energy and ultrasonic energy. A combination modular shaft assembly 3414 may be powered by the common first stage circuit 3404 located within a handle assembly 3412 and the modular second stage circuit 3406 integral to the modular shaft assembly 3414. As previously discussed throughout this description in connection with the surgical instruments of surgical system 1000, a battery assembly 3410 and the shaft assembly 3414 are configured to mechanically and electrically connect to the handle assembly 3412. The end effector assembly is configured to mechanically and electrically connect the shaft assembly 3414.

[0501] Turning now to FIG. 34, the generator circuit 3400 is partitioned into multiple stages located in multiple modular assemblies of a surgical instrument, such as the surgical instruments of surgical system 1000 described herein. In one aspect, a control stage circuit 3402 may be located in the battery assembly 3410 of the surgical instrument. The control stage circuit 3402 is a control circuit 3200 as described in connection with FIG. 32. The control circuit 3200 comprises a processor 3214, which includes internal memory 3217 (FIG. 34) (e.g., volatile and non-volatile memory), and is electrically coupled to a battery 3211. The battery 3211 supplies power to the first stage circuit 3404, the second stage circuit 3406, and a third stage circuit 3408, respectively. As previously discussed, the control circuit 3200 generates a digital waveform 4300 (FIG. 43) using circuits and techniques described in connection with FIGS. 41 and 42. Returning to FIG. 34, the digital waveform 4300 may be configured to drive an ultrasonic transducer, high-frequency

(e.g., RF) electrodes, or a combination thereof either independently or simultaneously. If driven simultaneously, filter circuits may be provided in the corresponding first stage circuits 3404 to select either the ultrasonic waveform or the RF waveform. Such filtering techniques are described in commonly owned U.S. Pat. Pub. No. US-2017-0086910-A1, titled TECHNIQUES FOR CIRCUIT TOPOLOGIES FOR COMBINED GENERATOR, which is herein incorporated by reference in its entirety.

[0502] The first stage circuits 3404 (e.g., the first stage ultrasonic drive circuit 3420, the first stage RF drive circuit 3422, and the first stage sensor drive circuit 3424) are located in a handle assembly 3412 of the surgical instrument. The control circuit 3200 provides the ultrasonic drive signal to the first stage ultrasonic drive circuit 3420 via outputs SCL-A, SDA-A of the control circuit 3200. The first stage ultrasonic drive circuit 3420 is described in detail in connection with FIG. 29. The control circuit 3200 provides the RF drive signal to the first stage RF drive circuit 3422 via outputs SCL-B, SDA-B of the control circuit 3200. The first stage RF drive circuit 3422 is described in detail in connection with FIG. 36. The control circuit 3200 provides the sensor drive signal to the first stage sensor drive circuit 3424 via outputs SCL-C, SDA-C of the control circuit 3200. Generally, each of the first stage circuits 3404 includes a digital-to-analog (DAC) converter and a first stage amplifier section to drive the second stage circuits 3406. The outputs of the first stage circuits 3404 are provided to the inputs of the second stage circuits 3406.

[0503] The control circuit 3200 is configured to detect which modules are plugged into the control circuit 3200. For example, the control circuit 3200 is configured to detect whether the first stage ultrasonic drive circuit 3420, the first stage RF drive circuit 3422, or the first stage sensor drive circuit 3424 located in the handle assembly 3412 is connected to the battery assembly 3410. Likewise, each of the first stage circuits 3404 can detect which second stage circuits 3406 are connected thereto and that information is provided back to the control circuit 3200 to determine the type of signal waveform to generate. Similarly, each of the second stage circuits 3406 can detect which third stage circuits 3408 or components are connected thereto and that information is provided back to the control circuit 3200 to determine the type of signal waveform to generate.

[0504] In one aspect, the second stage circuits 3406 (e.g., the ultrasonic drive second stage circuit 3430, the RF drive second stage circuit 3432, and the sensor drive second stage circuit 3434) are located in the shaft assembly 3414 of the surgical instrument. The first stage ultrasonic drive circuit 3420 provides a signal to the second stage ultrasonic drive circuit 3430 via outputs US-Left/US-Right. The second stage ultrasonic drive circuit 3430 is described in detail in connection with FIGS. 30 and 31. In addition to a transformer (FIGS. 30 and 31), the second stage ultrasonic drive circuit 3430 also may include filter, amplifier, and signal conditioning circuits. The first stage high-frequency (RF) current drive circuit 3422 provides a signal to the second stage RF drive circuit 3432 via outputs RF-Left/RF-Right. In addition to a transformer and blocking capacitors, the second stage RF drive circuit 3432 also may include filter, amplifier, and signal conditioning circuits. The first stage sensor drive circuit 3424 provides a signal to the second stage sensor drive circuit 3434 via outputs Sensor-1/Sensor-2. The second stage sensor drive circuit 3434 may include

filter, amplifier, and signal conditioning circuits depending on the type of sensor. The outputs of the second stage circuits **3406** are provided to the inputs of the third stage circuits **3408**.

[0505] In one aspect, the third stage circuits **3408** (e.g., the ultrasonic transducer **1120**, the RF electrodes **3074a**, **3074b**, and the sensors **3440**) may be located in various assemblies **3416** of the surgical instruments. In one aspect, the second stage ultrasonic drive circuit **3430** provides a drive signal to the ultrasonic transducer **1120** piezoelectric stack. In one aspect, the ultrasonic transducer **1120** is located in the ultrasonic transducer assembly of the surgical instrument. In other aspects, however, the ultrasonic transducer **1120** may be located in the handle assembly **3412**, the shaft assembly **3414**, or the end effector. In one aspect, the second stage RF drive circuit **3432** provides a drive signal to the RF electrodes **3074a**, **3074b**, which are generally located in the end effector portion of the surgical instrument. In one aspect, the second stage sensor drive circuit **3434** provides a drive signal to various sensors **3440** located throughout the surgical instrument.

[0506] FIG. **35** illustrates a generator circuit **3500** partitioned into multiple stages where a first stage circuit **3504** is common to the second stage circuit **3506**, in accordance with at least one aspect of the present disclosure. In one aspect, the surgical instruments of surgical system **1000** described herein may comprise generator circuit **3500** partitioned into multiple stages. For example, the surgical instruments of surgical system **1000** may comprise the generator circuit **3500** partitioned into at least two circuits: the first stage circuit **3504** and the second stage circuit **3506** of amplification enabling operation of high-frequency (RF) energy only, ultrasonic energy only, and/or a combination of RF energy and ultrasonic energy. A combination modular shaft assembly **3514** may be powered by a common first stage circuit **3504** located within the handle assembly **3512** and a modular second stage circuit **3506** integral to the modular shaft assembly **3514**. As previously discussed throughout this description in connection with the surgical instruments of surgical system **1000**, a battery assembly **3510** and the shaft assembly **3514** are configured to mechanically and electrically connect to the handle assembly **3512**. The end effector assembly is configured to mechanically and electrically connect the shaft assembly **3514**.

[0507] As shown in the example of FIG. **35**, the battery assembly **3510** portion of the surgical instrument comprises a first control circuit **3502**, which includes the control circuit **3200** previously described. The handle assembly **3512**, which connects to the battery assembly **3510**, comprises a common first stage drive circuit **3420**. As previously discussed, the first stage drive circuit **3420** is configured to drive ultrasonic, high-frequency (RF) current, and sensor loads. The output of the common first stage drive circuit **3420** can drive any one of the second stage circuits **3506** such as the second stage ultrasonic drive circuit **3430**, the second stage high-frequency (RF) current drive circuit **3432**, and/or the second stage sensor drive circuit **3434**. The common first stage drive circuit **3420** detects which second stage circuit **3506** is located in the shaft assembly **3514** when the shaft assembly **3514** is connected to the handle assembly **3512**. Upon the shaft assembly **3514** being connected to the handle assembly **3512**, the common first stage drive circuit **3420** determines which one of the second stage circuits **3506** (e.g., the second stage ultrasonic drive circuit **3430**, the

second stage RF drive circuit **3432**, and/or the second stage sensor drive circuit **3434**) is located in the shaft assembly **3514**. The information is provided to the control circuit **3200** located in the handle assembly **3512** in order to supply a suitable digital waveform **4300** (FIG. **43**) to the second stage circuit **3506** to drive the appropriate load, e.g., ultrasonic, RF, or sensor. It will be appreciated that identification circuits may be included in various assemblies **3516** in third stage circuit **3508** such as the ultrasonic transducer **1120**, the electrodes **3074a**, **3074b**, or the sensors **3440**. Thus, when a third stage circuit **3508** is connected to a second stage circuit **3506**, the second stage circuit **3506** knows the type of load that is required based on the identification information.

[0508] FIG. **36** is a schematic diagram of one aspect of an electrical circuit **3600** configured to drive a high-frequency current (RF), in accordance with at least one aspect of the present disclosure. The electrical circuit **3600** comprises an analog multiplexer **3680**. The analog multiplexer **3680** multiplexes various signals from the upstream channels SCL-A, SDA-A such as RF, battery, and power control circuit. A current sensor **3682** is coupled in series with the return or ground leg of the power supply circuit to measure the current supplied by the power supply. A field effect transistor (FET) temperature sensor **3684** provides the ambient temperature. A pulse width modulation (PWM) watchdog timer **3688** automatically generates a system reset if the main program neglects to periodically service it. It is provided to automatically reset the electrical circuit **3600** when it hangs or freezes because of a software or hardware fault. It will be appreciated that the electrical circuit **3600** may be configured for driving RF electrodes or for driving the ultrasonic transducer **1120** as described in connection with FIG. **29**, for example. Accordingly, with reference now back to FIG. **36**, the electrical circuit **3600** can be used to drive both ultrasonic and RF electrodes interchangeably.

[0509] A drive circuit **3686** provides Left and Right RF energy outputs. A digital signal that represents the signal waveform is provided to the SCL-A, SDA-A inputs of the analog multiplexer **3680** from a control circuit, such as the control circuit **3200** (FIG. **32**). A digital-to-analog converter **3690** (DAC) converts the digital input to an analog output to drive a PWM circuit **3692** coupled to an oscillator **3694**. The PWM circuit **3692** provides a first signal to a first gate drive circuit **3696a** coupled to a first transistor output stage **3698a** to drive a first RF+(Left) energy output. The PWM circuit **3692** also provides a second signal to a second gate drive circuit **3696b** coupled to a second transistor output stage **3698b** to drive a second RF- (Right) energy output. A voltage sensor **3699** is coupled between the RF Left/RF output terminals to measure the output voltage. The drive circuit **3686**, the first and second drive circuits **3696a**, **3696b**, and the first and second transistor output stages **3698a**, **3698b** define a first stage amplifier circuit. In operation, the control circuit **3200** (FIG. **32**) generates a digital waveform **4300** (FIG. **43**) employing circuits such as direct digital synthesis (DDS) circuits **4100**, **4200** (FIGS. **41** and **42**). The DAC **3690** receives the digital waveform **4300** and converts it into an analog waveform, which is received and amplified by the first stage amplifier circuit.

[0510] FIG. **37** is a schematic diagram of the transformer **3700** coupled to the electrical circuit **3600** shown in FIG. **36**, in accordance with at least one aspect of the present disclosure. The RF+/RF- input terminals (primary winding) of the transformer **3700** are electrically coupled to the RF Left/RF

output terminals of the electrical circuit **3600**. One side of the secondary winding is coupled in series with first and second blocking capacitors **3706**, **3708**. The second blocking capacitor is coupled to the second stage RF drive circuit **3774a** positive terminal. The other side of the secondary winding is coupled to the second stage RF drive circuit **3774b** negative terminal. The second stage RF drive circuit **3774a** positive output is coupled to the ultrasonic blade and the second stage RF drive circuit **3774b** negative ground terminal is coupled to an outer tube. In one aspect, a transformer has a turns-ratio of $n_1:n_2$ of 1:50.

[0511] FIG. 38 is a schematic diagram of a circuit **3800** comprising separate power sources for high power energy/drive circuits and low power circuits, in accordance with at least one aspect of the present disclosure. A power supply **3812** includes a primary battery pack comprising first and second primary batteries **3815**, **3817** (e.g., Li-ion batteries) that are connected into the circuit **3800** by a switch **3818** and a secondary battery pack comprising a secondary battery **3820** that is connected into the circuit by a switch **3823** when the power supply **3812** is inserted into the battery assembly. The secondary battery **3820** is a sag preventing battery that has componentry resistant to gamma or other radiation sterilization. For instance, a switch mode power supply **3827** and optional charge circuit within the battery assembly can be incorporated to allow the secondary battery **3820** to reduce the voltage sag of the primary batteries **3815**, **3817**. This guarantees full charged cells at the beginning of a surgery that are easy to introduce into the sterile field. The primary batteries **3815**, **3817** can be used to power motor control circuits **3826** and energy circuits **3832** directly. The motor control circuits **3826** are configured to control a motor, such as motor **3829**. The power supply/battery pack **3812** may comprise a dual type battery assembly including primary Li-ion batteries **3815**, **3817** and secondary NiMH batteries **3820** with dedicated energy cells **3820** to control handle electronics circuits **3830** from dedicated energy cells **3815**, **3817** to run the motor control circuits **3826** and the energy circuits **3832**. In this case the circuit **3810** pulls from the secondary batteries **3820** involved in driving the handle electronics circuits **3830** when the primary batteries **3815**, **3817** involved in driving the energy circuits **3832** and/or motor control circuits **3826** are dropping low. In one various aspect, the circuit **3810** may include a one way diode that would not allow for current to flow in the opposite direction (e.g., from the batteries involved in driving the energy and/or motor control circuits to the batteries involved in driving the electronics circuits).

[0512] Additionally, a gamma friendly charge circuit may be provided that includes a switch mode power supply **3827** using diodes and vacuum tube components to minimize voltage sag at a predetermined level. With the inclusion of a minimum sag voltage that is a division of the NiMH voltages (3 NiMH cells) the switch mode power supply **3827** could be eliminated. Additionally a modular system may be provided wherein the radiation hardened components are located in a module, making the module sterilizable by radiation sterilization. Other non-radiation hardened components may be included in other modular components and connections made between the modular components such that the componentry operates together as if the components were located together on the same circuit board. If only two NiMH cells are desired the switch mode power supply **3827**

based on diodes and vacuum tubes allows for sterilizable electronics within the disposable primary battery pack.

[0513] Turning now to FIG. 39, there is shown a control circuit **3900** for operating a battery **3901** powered RF generator circuit **3902** for use with a surgical instrument, in accordance with at least one aspect of the present disclosure. The surgical instrument is configured to use both ultrasonic vibration and high-frequency current to carry out surgical coagulation/cutting treatments on living tissue, and uses high-frequency current to carry out a surgical coagulation treatment on living tissue.

[0514] FIG. 39 illustrates the control circuit **3900** that allows a dual generator system to switch between the RF generator circuit **3902** and the ultrasonic generator circuit **3920** energy modalities for a surgical instrument of the surgical system **1000**. In one aspect, a current threshold in an RF signal is detected. When the impedance of the tissue is low the high-frequency current through tissue is high when RF energy is used as the treatment source for the tissue. According to one aspect, a visual indicator **3912** or light located on the surgical instrument of surgical system **1000** may be configured to be in an on-state during this high current period. When the current falls below a threshold, the visual indicator **3912** is in an off-state. Accordingly, a phototransistor **3914** may be configured to detect the transition from an on-state to an off-state and disengages the RF energy as shown in the control circuit **3900** shown in FIG. 39. Therefore, when the energy button is released and an energy switch **3926** is opened, the control circuit **3900** is reset and both the RF and ultrasonic generator circuits **3902**, **3920** are held off.

[0515] With reference to FIG. 39, in one aspect, a method of managing an RF generator circuit **3902** and ultrasound generator circuit **3920** is provided. The RF generator circuit **3902** and/or the ultrasound generator circuit **3920** may be located in the handle assembly **1109**, the ultrasonic transducer/RF generator assembly **1120**, the battery assembly, the shaft assembly **1129**, and/or the nozzle, of the multifunction electrosurgical instrument **1108**, for example. The control circuit **3900** is held in a reset state if the energy switch **3926** is off (e.g., open). Thus, when the energy switch **3926** is opened, the control circuit **3900** is reset and both the RF and ultrasonic generator circuits **3902**, **3920** are turned off. When the energy switch **3926** is squeezed and the energy switch **3926** is engaged (e.g., closed), RF energy is delivered to the tissue and the visual indicator **3912** operated by a current sensing step-up transformer **3904** will be lit while the tissue impedance is low. The light from the visual indicator **3912** provides a logic signal to keep the ultrasonic generator circuit **3920** in the off state. Once the tissue impedance increases above a threshold and the high-frequency current through the tissue decreases below a threshold, the visual indicator **3912** turns off and the light transitions to an off-state. A logic signal generated by this transition turns off a relay **3908**, whereby the RF generator circuit **3902** is turned off and the ultrasonic generator circuit **3920** is turned on, to complete the coagulation and cut cycle.

[0516] Still with reference to FIG. 39, in one aspect, the dual generator circuit configuration employs the on-board RF generator circuit **3902**, which is battery **3901** powered, for one modality and a second, on-board ultrasound generator circuit **3920**, which may be on-board in the handle assembly **1109**, battery assembly, shaft assembly **1129**, nozzle, and/or the ultrasonic transducer/RF generator assem-

bly **1120** of the multifunction electrosurgical instrument **1108**, for example. The ultrasonic generator circuit **3920** also is battery **3901** operated. In various aspects, the RF generator circuit **3902** and the ultrasonic generator circuit **3920** may be an integrated or separable component of the handle assembly **1109**. According to various aspects, having the dual RF/ultrasonic generator circuits **3902**, **3920** as part of the handle assembly **1109** may eliminate the need for complicated wiring. The RF/ultrasonic generator circuits **3902**, **3920** may be configured to provide the full capabilities of an existing generator while utilizing the capabilities of a cordless generator system simultaneously.

[**0517**] Either type of system can have separate controls for the modalities that are not communicating with each other. The surgeon activates the RF and Ultrasonic separately and at their discretion. Another approach would be to provide fully integrated communication schemes that share buttons, tissue status, instrument operating parameters (such as jaw closure, forces, etc.) and algorithms to manage tissue treatment. Various combinations of this integration can be implemented to provide the appropriate level of function and performance.

[**0518**] As discussed above, in one aspect, the control circuit **3900** includes the battery **3901** powered RF generator circuit **3902** comprising a battery as an energy source. As shown, RF generator circuit **3902** is coupled to two electrically conductive surfaces referred to herein as electrodes **3906a**, **3906b** (i.e., active electrode **3906a** and return electrode **3906b**) and is configured to drive the electrodes **3906a**, **3906b** with RF energy (e.g., high-frequency current). A first winding **3910a** of the step-up transformer **3904** is connected in series with one pole of the bipolar RF generator circuit **3902** and the return electrode **3906b**. In one aspect, the first winding **3910a** and the return electrode **3906b** are connected to the negative pole of the bipolar RF generator circuit **3902**. The other pole of the bipolar RF generator circuit **3902** is connected to the active electrode **3906a** through a switch contact **3909** of the relay **3908**, or any suitable electromagnetic switching device comprising an armature which is moved by an electromagnet **3936** to operate the switch contact **3909**. The switch contact **3909** is closed when the electromagnet **3936** is energized and the switch contact **3909** is open when the electromagnet **3936** is de-energized. When the switch contact is closed, RF current flows through conductive tissue (not shown) located between the electrodes **3906a**, **3906b**. It will be appreciated, that in one aspect, the active electrode **3906a** is connected to the positive pole of the bipolar RF generator circuit **3902**.

[**0519**] A visual indicator circuit **3905** comprises the step-up transformer **3904**, a series resistor R2, and the visual indicator **3912**. The visual indicator **3912** can be adapted for use with the surgical instrument **1108** and other electrosurgical systems and tools, such as those described herein. The first winding **3910a** of the step-up transformer **3904** is connected in series with the return electrode **3906b** and the second winding **3910b** of the step-up transformer **3904** is connected in series with the resistor R2 and the visual indicator **3912** comprising a type NE-2 neon bulb, for example.

[**0520**] In operation, when the switch contact **3909** of the relay **3908** is open, the active electrode **3906a** is disconnected from the positive pole of the bipolar RF generator circuit **3902** and no current flows through the tissue, the return electrode **3906b**, and the first winding **3910a** of the

step-up transformer **3904**. Accordingly, the visual indicator **3912** is not energized and does not emit light. When the switch contact **3909** of the relay **3908** is closed, the active electrode **3906a** is connected to the positive pole of the bipolar RF generator circuit **3902** enabling current to flow through tissue, the return electrode **3906b**, and the first winding **3910a** of the step-up transformer **3904** to operate on tissue, for example cut and cauterize the tissue.

[**0521**] A first current flows through the first winding **3910a** as a function of the impedance of the tissue located between the active and return electrodes **3906a**, **3906b** providing a first voltage across the first winding **3910a** of the step-up transformer **3904**. A stepped up second voltage is induced across the second winding **3910b** of the step-up transformer **3904**. The secondary voltage appears across the resistor R2 and energizes the visual indicator **3912** causing the neon bulb to light when the current through the tissue is greater than a predetermined threshold. It will be appreciated that the circuit and component values are illustrative and not limited thereto. When the switch contact **3909** of the relay **3908** is closed, current flows through the tissue and the visual indicator **3912** is turned on.

[**0522**] Turning now to the energy switch **3926** portion of the control circuit **3900**, when the energy switch **3926** is open position, a logic high is applied to the input of a first inverter **3928** and a logic low is applied of one of the two inputs of the AND gate **3932**. Thus, the output of the AND gate **3932** is low and a transistor **3934** is off to prevent current from flowing through the winding of the electromagnet **3936**. With the electromagnet **3936** in the de-energized state, the switch contact **3909** of the relay **3908** remains open and prevents current from flowing through the electrodes **3906a**, **3906b**. The logic low output of the first inverter **3928** also is applied to a second inverter **3930** causing the output to go high and resetting a flip-flop **3918** (e.g., a D-Type flip-flop). At which time, the Q output goes low to turn off the ultrasound generator circuit **3920** circuit and the Q output goes high and is applied to the other input of the AND gate **3932**.

[**0523**] When the user presses the energy switch **3926** on the instrument handle to apply energy to the tissue between the electrodes **3906a**, **3906b**, the energy switch **3926** closes and applies a logic low at the input of the first inverter **3928**, which applies a logic high to other input of the AND gate **3932** causing the output of the AND gate **3932** to go high and turns on the transistor **3934**. In the on state, the transistor **3934** conducts and sinks current through the winding of the electromagnet **3936** to energize the electromagnet **3936** and close the switch contact **3909** of the relay **3908**. As discussed above, when the switch contact **3909** is closed, current can flow through the electrodes **3906a**, **3906b** and the first winding **3910a** of the step-up transformer **3904** when tissue is located between the electrodes **3906a**, **3906b**.

[**0524**] As discussed above, the magnitude of the current flowing through the electrodes **3906a**, **3906b** depends on the impedance of the tissue located between the electrodes **3906a**, **3906b**. Initially, the tissue impedance is low and the magnitude of the current high through the tissue and the first winding **3910a**. Consequently, the voltage impressed on the second winding **3910b** is high enough to turn on the visual indicator **3912**. The light emitted by the visual indicator **3912** turns on the phototransistor **3914**, which pulls the input of an inverter **3916** low and causes the output of the inverter **3916** to go high. A high input applied to the CLK of the

flip-flop 3918 has no effect on the Q or the \bar{Q} outputs of the flip-flop 3918 and Q output remains low and the \bar{Q} output remains high. Accordingly, while the visual indicator 3912 remains energized, the ultrasound generator circuit 3920 is turned OFF and an ultrasonic transducer 3922 and an ultrasonic blade 3924 of the multifunction electro-surgical instrument are not activated.

[0525] As the tissue between the electrodes 3906a, 3906b dries up, due to the heat generated by the current flowing through the tissue, the impedance of the tissue increases and the current there-through decreases. When the current through the first winding 3910a decreases, the voltage across the second winding 3910b also decreases and when the voltage drops below a minimum threshold required to operate the visual indicator 3912, the visual indicator 3912 and the phototransistor 3914 turn off. When the phototransistor 3914 turns off, a logic high is applied to the input of the inverter 3916 and a logic low is applied to the CLK input of the flip-flop 3918 to clock a logic high to the Q output and a logic low to the \bar{Q} output. The logic high at the Q output turns on the ultrasound generator circuit 3920 to activate the ultrasonic transducer 3922 and the ultrasonic blade 3924 to initiate cutting the tissue located between the electrodes 3906a, 3906b. Simultaneously or near simultaneously with the ultrasound generator circuit 3920 turning on, the \bar{Q} output of the flip-flop 3918 goes low and causes the output of the AND gate 3932 to go low and turn off the transistor 3934, thereby de-energizing the electromagnet 3936 and opening the switch contact 3909 of the relay 3908 to cut off the flow of current through the electrodes 3906a, 3906b.

[0526] While the switch contact 3909 of the relay 3908 is open, no current flows through the electrodes 3906a, 3906b, tissue, and the first winding 3910a of the step-up transformer 3904. Therefore, no voltage is developed across the second winding 3910b and no current flows through the visual indicator 3912.

[0527] The state of the Q and the \bar{Q} outputs of the flip-flop 3918 remain the same while the user squeezes the energy switch 3926 on the instrument handle to maintain the energy switch 3926 closed. Thus, the ultrasonic blade 3924 remains activated and continues cutting the tissue between the jaws of the end effector while no current flows through the electrodes 3906a, 3906b from the bipolar RF generator circuit 3902. When the user releases the energy switch 3926 on the instrument handle, the energy switch 3926 opens and the output of the first inverter 3928 goes low and the output of the second inverter 3930 goes high to reset the flip-flop 3918 causing the Q output to go low and turn off the ultrasound generator circuit 3920. At the same time, the \bar{Q} output goes high and the circuit is now in an off state and ready for the user to actuate the energy switch 3926 on the instrument handle to close the energy switch 3926, apply current to the tissue located between the electrodes 3906a, 3906b, and repeat the cycle of applying RF energy to the tissue and ultrasonic energy to the tissue as described above.

[0528] FIG. 40 illustrates a diagram of a surgical system 4000, which represents one aspect of the surgical system 1000, comprising a feedback system for use with any one of the surgical instruments of surgical system 1000, which may include or implement many of the features described herein. The surgical system 4000 may include a generator 4002 coupled to a surgical instrument that includes an end effector 4006, which may be activated when a clinician operates a trigger 4010. In various aspects, the end effector 4006 may

include an ultrasonic blade to deliver ultrasonic vibration to carry out surgical coagulation/cutting treatments on living tissue. In other aspects the end effector 4006 may include electrically conductive elements coupled to an electro-surgical high-frequency current energy source to carry out surgical coagulation or cauterization treatments on living tissue and either a mechanical knife with a sharp edge or an ultrasonic blade to carry out cutting treatments on living tissue. When the trigger 4010 is actuated, a force sensor 4012 may generate a signal indicating the amount of force being applied to the trigger 4010. In addition to, or instead of a force sensor 4012, the surgical instrument may include a position sensor 4013, which may generate a signal indicating the position of the trigger 4010 (e.g., how far the trigger has been depressed or otherwise actuated). In one aspect, the position sensor 4013 may be a sensor positioned with an outer tubular sheath or reciprocating tubular actuating member located within the outer tubular sheath of the surgical instrument. In one aspect, the sensor may be a Hall-effect sensor or any suitable transducer that varies its output voltage in response to a magnetic field. The Hall-effect sensor may be used for proximity switching, positioning, speed detection, and current sensing applications. In one aspect, the Hall-effect sensor operates as an analog transducer, directly returning a voltage. With a known magnetic field, its distance from the Hall plate can be determined.

[0529] A control circuit 4008 may receive the signals from the sensors 4012 and/or 4013. The control circuit 4008 may include any suitable analog or digital circuit components. The control circuit 4008 also may communicate with the generator 4002 and/or a transducer 4004 to modulate the power delivered to the end effector 4006 and/or the generator level or ultrasonic blade amplitude of the end effector 4006 based on the force applied to the trigger 4010 and/or the position of the trigger 4010 and/or the position of the outer tubular sheath described above relative to a reciprocating tubular actuating member located within an outer tubular sheath (e.g., as measured by a Hall-effect sensor and magnet combination). For example, as more force is applied to the trigger 4010, more power and/or higher ultrasonic blade amplitude may be delivered to the end effector 4006. According to various aspects, the force sensor 4012 may be replaced by a multi-position switch.

[0530] According to various aspects, the end effector 4006 may include a clamp or clamping mechanism. When the trigger 4010 is initially actuated, the clamping mechanism may close, clamping tissue between a clamp arm and the end effector 4006. As the force applied to the trigger increases (e.g., as sensed by force sensor 4012) the control circuit 4008 may increase the power delivered to the end effector 4006 by the transducer 4004 and/or the generator level or ultrasonic blade amplitude brought about in the end effector 4006. In one aspect, trigger position, as sensed by position sensor 4013 or clamp or clamp arm position, as sensed by position sensor 4013 (e.g., with a Hall-effect sensor), may be used by the control circuit 4008 to set the power and/or amplitude of the end effector 4006. For example, as the trigger is moved further towards a fully actuated position, or the clamp or clamp arm moves further towards the ultrasonic blade (or end effector 4006), the power and/or amplitude of the end effector 4006 may be increased.

[0531] According to various aspects, the surgical instrument of the surgical system 4000 also may include one or more feedback devices for indicating the amount of power

delivered to the end effector **4006**. For example, a speaker **4014** may emit a signal indicative of the end effector power. According to various aspects, the speaker **4014** may emit a series of pulse sounds, where the frequency of the sounds indicates power. In addition to, or instead of the speaker **4014**, the surgical instrument may include a visual display **4016**. The visual display **4016** may indicate end effector power according to any suitable method. For example, the visual display **4016** may include a series of LEDs, where end effector power is indicated by the number of illuminated LEDs. The speaker **4014** and/or visual display **4016** may be driven by the control circuit **4008**. According to various aspects, the surgical instrument may include a ratcheting device connected to the trigger **4010**. The ratcheting device may generate an audible sound as more force is applied to the trigger **4010**, providing an indirect indication of end effector power. The surgical instrument may include other features that may enhance safety. For example, the control circuit **4008** may be configured to prevent power from being delivered to the end effector **4006** in excess of a predetermined threshold. Also, the control circuit **4008** may implement a delay between the time when a change in end effector power is indicated (e.g., by speaker **4014** or visual display **4016**), and the time when the change in end effector power is delivered. In this way, a clinician may have ample warning that the level of ultrasonic power that is to be delivered to the end effector **4006** is about to change.

[**0532**] In one aspect, the ultrasonic or high-frequency current generators of the surgical system **1000** may be configured to generate the electrical signal waveform digitally such that the desired using a predetermined number of phase points stored in a lookup table to digitize the wave shape. The phase points may be stored in a table defined in a memory, a field programmable gate array (FPGA), or any suitable non-volatile memory. FIG. **41** illustrates one aspect of a fundamental architecture for a digital synthesis circuit such as a direct digital synthesis (DDS) circuit **4100** configured to generate a plurality of wave shapes for the electrical signal waveform. The generator software and digital controls may command the FPGA to scan the addresses in the lookup table **4104** which in turn provides varying digital input values to a DAC circuit **4108** that feeds a power amplifier. The addresses may be scanned according to a frequency of interest. Using such a lookup table **4104** enables generating various types of wave shapes that can be fed into tissue or into a transducer, an RF electrode, multiple transducers simultaneously, multiple RF electrodes simultaneously, or a combination of RF and ultrasonic instruments. Furthermore, multiple lookup tables **4104** that represent multiple wave shapes can be created, stored, and applied to tissue from a generator.

[**0533**] The waveform signal may be configured to control at least one of an output current, an output voltage, or an output power of an ultrasonic transducer and/or an RF electrode, or multiples thereof (e.g. two or more ultrasonic transducers and/or two or more RF electrodes). Further, where the surgical instrument comprises an ultrasonic components, the waveform signal may be configured to drive at least two vibration modes of an ultrasonic transducer of the at least one surgical instrument. Accordingly, a generator may be configured to provide a waveform signal to at least one surgical instrument wherein the waveform signal corresponds to at least one wave shape of a plurality of wave shapes in a table. Further, the waveform signal provided to

the two surgical instruments may comprise two or more wave shapes. The table may comprise information associated with a plurality of wave shapes and the table may be stored within the generator. In one aspect or example, the table may be a direct digital synthesis table, which may be stored in an FPGA of the generator. The table may be addressed by anyway that is convenient for categorizing wave shapes. According to one aspect, the table, which may be a direct digital synthesis table, is addressed according to a frequency of the waveform signal. Additionally, the information associated with the plurality of wave shapes may be stored as digital information in the table.

[**0534**] The analog electrical signal waveform may be configured to control at least one of an output current, an output voltage, or an output power of an ultrasonic transducer and/or an RF electrode, or multiples thereof (e.g., two or more ultrasonic transducers and/or two or more RF electrodes). Further, where the surgical instrument comprises ultrasonic components, the analog electrical signal waveform may be configured to drive at least two vibration modes of an ultrasonic transducer of the at least one surgical instrument. Accordingly, the generator circuit may be configured to provide an analog electrical signal waveform to at least one surgical instrument wherein the analog electrical signal waveform corresponds to at least one wave shape of a plurality of wave shapes stored in a lookup table **4104**. Further, the analog electrical signal waveform provided to the two surgical instruments may comprise two or more wave shapes. The lookup table **4104** may comprise information associated with a plurality of wave shapes and the lookup table **4104** may be stored either within the generator circuit or the surgical instrument. In one aspect or example, the lookup table **4104** may be a direct digital synthesis table, which may be stored in an FPGA of the generator circuit or the surgical instrument. The lookup table **4104** may be addressed by anyway that is convenient for categorizing wave shapes. According to one aspect, the lookup table **4104**, which may be a direct digital synthesis table, is addressed according to a frequency of the desired analog electrical signal waveform. Additionally, the information associated with the plurality of wave shapes may be stored as digital information in the lookup table **4104**.

[**0535**] With the widespread use of digital techniques in instrumentation and communications systems, a digitally-controlled method of generating multiple frequencies from a reference frequency source has evolved and is referred to as direct digital synthesis. The basic architecture is shown in FIG. **41**. In this simplified block diagram, a DDS circuit is coupled to a processor, controller, or a logic device of the generator circuit and to a memory circuit located in the generator circuit of the surgical system **1000**. The DDS circuit **4100** comprises an address counter **4102**, lookup table **4104**, a register **4106**, a DAC circuit **4108**, and a filter **4112**. A stable clock f_c is received by the address counter **4102** and the register **4106** drives a programmable-read-only-memory (PROM) which stores one or more integral number of cycles of a sinewave (or other arbitrary waveform) in a lookup table **4104**. As the address counter **4102** steps through memory locations, values stored in the lookup table **4104** are written to the register **4106**, which is coupled to the DAC circuit **4108**. The corresponding digital amplitude of the signal at the memory location of the lookup table **4104** drives the DAC circuit **4108**, which in turn generates an analog output signal **4110**. The spectral purity of the

analog output signal **4110** is determined primarily by the DAC circuit **4108**. The phase noise is basically that of the reference clock f_c . The first analog output signal **4110** output from the DAC circuit **4108** is filtered by the filter **4112** and a second analog output signal **4114** output by the filter **4112** is provided to an amplifier having an output coupled to the output of the generator circuit. The second analog output signal has a frequency f_{out} .

[0536] Because the DDS circuit **4100** is a sampled data system, issues involved in sampling must be considered: quantization noise, aliasing, filtering, etc. For instance, the higher order harmonics of the DAC circuit **4108** output frequencies fold back into the Nyquist bandwidth, making them unfilterable, whereas, the higher order harmonics of the output of phase-locked-loop (PLL) based synthesizers can be filtered. The lookup table **4104** contains signal data for an integral number of cycles. The final output frequency f_{out} can be changed changing the reference clock frequency f_c or by reprogramming the PROM.

[0537] The DDS circuit **4100** may comprise multiple lookup tables **4104** where the lookup table **4104** stores a waveform represented by a predetermined number of samples, wherein the samples define a predetermined shape of the waveform. Thus multiple waveforms having a unique shape can be stored in multiple lookup tables **4104** to provide different tissue treatments based on instrument settings or tissue feedback. Examples of waveforms include high crest factor RF electrical signal waveforms for surface tissue coagulation, low crest factor RF electrical signal waveform for deeper tissue penetration, and electrical signal waveforms that promote efficient touch-up coagulation. In one aspect, the DDS circuit **4100** can create multiple wave shape lookup tables **4104** and during a tissue treatment procedure (e.g., “on-the-fly” or in virtual real time based on user or sensor inputs) switch between different wave shapes stored in separate lookup tables **4104** based on the tissue effect desired and/or tissue feedback.

[0538] Accordingly, switching between wave shapes can be based on tissue impedance and other factors, for example. In other aspects, the lookup tables **4104** can store electrical signal waveforms shaped to maximize the power delivered into the tissue per cycle (i.e., trapezoidal or square wave). In other aspects, the lookup tables **4104** can store wave shapes synchronized in such way that they make maximizing power delivery by the multifunction surgical instrument of surgical system **1000** while delivering RF and ultrasonic drive signals. In yet other aspects, the lookup tables **4104** can store electrical signal waveforms to drive ultrasonic and RF therapeutic, and/or sub-therapeutic, energy simultaneously while maintaining ultrasonic frequency lock. Custom wave shapes specific to different instruments and their tissue effects can be stored in the non-volatile memory of the generator circuit or in the non-volatile memory (e.g., EEPROM) of the surgical system **1000** and be fetched upon connecting the multifunction surgical instrument to the generator circuit. An example of an exponentially damped sinusoid, as used in many high crest factor “coagulation” waveforms is shown in FIG. **43**.

[0539] A more flexible and efficient implementation of the DDS circuit **4100** employs a digital circuit called a Numerically Controlled Oscillator (NCO). A block diagram of a more flexible and efficient digital synthesis circuit such as a DDS circuit **4200** is shown in FIG. **42**. In this simplified block diagram, a DDS circuit **4200** is coupled to a processor,

controller, or a logic device of the generator and to a memory circuit located either in the generator or in any of the surgical instruments of surgical system **1000**. The DDS circuit **4200** comprises a load register **4202**, a parallel delta phase register **4204**, an adder circuit **4216**, a phase register **4208**, a lookup table **4210** (phase-to-amplitude converter), a DAC circuit **4212**, and a filter **4214**. The adder circuit **4216** and the phase register **4208** form part of a phase accumulator **4206**. A clock frequency f_c is applied to the phase register **4208** and a DAC circuit **4212**. The load register **4202** receives a tuning word that specifies output frequency as a fraction of the reference clock frequency signal f_c . The output of the load register **4202** is provided to the parallel delta phase register **4204** with a tuning word M.

[0540] The DDS circuit **4200** includes a sample clock that generates the clock frequency f_c , the phase accumulator **4206**, and the lookup table **4210** (e.g., phase to amplitude converter). The content of the phase accumulator **4206** is updated once per clock cycle f_c . When time the phase accumulator **4206** is updated, the digital number, M, stored in the parallel delta phase register **4204** is added to the number in the phase register **4208** by the adder circuit **4216**. Assuming that the number in the parallel delta phase register **4204** is 00 . . . 01 and that the initial contents of the phase accumulator **4206** is 00 . . . 00. The phase accumulator **4206** is updated by 00 . . . 01 per clock cycle. If the phase accumulator **4206** is 32-bits wide, 232 clock cycles (over 4 billion) are required before the phase accumulator **4206** returns to 00 . . . 00, and the cycle repeats.

[0541] A truncated output **4218** of the phase accumulator **4206** is provided to a phase-to amplitude converter lookup table **4210** and the output of the lookup table **4210** is coupled to a DAC circuit **4212**. The truncated output **4218** of the phase accumulator **4206** serves as the address to a sine (or cosine) lookup table. An address in the lookup table corresponds to a phase point on the sinewave from 0° to 360°. The lookup table **4210** contains the corresponding digital amplitude information for one complete cycle of a sinewave. The lookup table **4210** therefore maps the phase information from the phase accumulator **4206** into a digital amplitude word, which in turn drives the DAC circuit **4212**. The output of the DAC circuit is a first analog signal **4220** and is filtered by a filter **4214**. The output of the filter **4214** is a second analog signal **4222**, which is provided to a power amplifier coupled to the output of the generator circuit.

[0542] In one aspect, the electrical signal waveform may be digitized into 1024 (210) phase points, although the wave shape may be digitized is any suitable number of 2n phase points ranging from 256 (28) to 281,474,976,710,656 (248), where n is a positive integer, as shown in TABLE 1. The electrical signal waveform may be expressed as $A_n(\theta_n)$, where a normalized amplitude A_n at a point n is represented by a phase angle θ_n is referred to as a phase point at point n. The number of discrete phase points n determines the tuning resolution of the DDS circuit **4200** (as well as the DDS circuit **4100** shown in FIG. **41**).

[0543] TABLE 1 specifies the electrical signal waveform digitized into a number of phase points.

TABLE 1

N	Number of Phase Points 2 ⁿ
8	256
10	1,024
12	4,096

TABLE 1-continued

N	Number of Phase Points 2^n
14	16,384
16	65,536
18	262,144
20	1,048,576
22	4,194,304
24	16,777,216
26	67,108,864
28	268,435,456
...	...
32	4,294,967,296
...	...
48	281,474,976,710,656
...	...

[0544] The generator circuit algorithms and digital control circuits scan the addresses in the lookup table **4210**, which in turn provides varying digital input values to the DAC circuit **4212** that feeds the filter **4214** and the power amplifier. The addresses may be scanned according to a frequency of interest. Using the lookup table enables generating various types of shapes that can be converted into an analog output signal by the DAC circuit **4212**, filtered by the filter **4214**, amplified by the power amplifier coupled to the output of the generator circuit, and fed to the tissue in the form of RF energy or fed to an ultrasonic transducer and applied to the tissue in the form of ultrasonic vibrations which deliver energy to the tissue in the form of heat. The output of the amplifier can be applied to an RF electrode, multiple RF electrodes simultaneously, an ultrasonic transducer, multiple ultrasonic transducers simultaneously, or a combination of RF and ultrasonic transducers, for example. Furthermore, multiple wave shape tables can be created, stored, and applied to tissue from a generator circuit.

[0545] With reference back to FIG. **41**, for $n=32$, and $M=1$, the phase accumulator **4206** steps through **232** possible outputs before it overflows and restarts. The corresponding output wave frequency is equal to the input clock frequency divided by 232. If $M=2$, then the phase register **1708** “rolls over” twice as fast, and the output frequency is doubled. This can be generalized as follows.

[0546] For a phase accumulator **4206** configured to accumulate n -bits (n generally ranges from 24 to 32 in most DDS systems, but as previously discussed n may be selected from a wide range of options), there are 2^n possible phase points. The digital word in the delta phase register, M , represents the amount the phase accumulator is incremented per clock cycle. If f_c is the clock frequency, then the frequency of the output sinewave is equal to:

$$f_0 = \frac{M \cdot f_c}{2^n}$$

[0547] The above equation is known as the DDS “tuning equation.” Note that the frequency resolution of the system is equal to $f_c/2^n$. For $n=32$, the resolution is greater than one part in four billion. In one aspect of the DDS circuit **4200**, not all of the bits out of the phase accumulator **4206** are passed on to the lookup table **4210**, but are truncated, leaving only the first **13** to **15** most significant bits (MSBs), for example. This reduces the size of the lookup table **4210**

and does not affect the frequency resolution. The phase truncation only adds a small but acceptable amount of phase noise to the final output.

[0548] The electrical signal waveform may be characterized by a current, voltage, or power at a predetermined frequency. Further, where any one of the surgical instruments of surgical system **1000** comprises ultrasonic components, the electrical signal waveform may be configured to drive at least two vibration modes of an ultrasonic transducer of the at least one surgical instrument. Accordingly, the generator circuit may be configured to provide an electrical signal waveform to at least one surgical instrument wherein the electrical signal waveform is characterized by a predetermined wave shape stored in the lookup table **4210** (or lookup table **4104** FIG. **41**). Further, the electrical signal waveform may be a combination of two or more wave shapes. The lookup table **4210** may comprise information associated with a plurality of wave shapes. In one aspect or example, the lookup table **4210** may be generated by the DDS circuit **4200** and may be referred to as a direct digital synthesis table. DDS works by first storing a large repetitive waveform in onboard memory. A cycle of a waveform (sine, triangle, square, arbitrary) can be represented by a predetermined number of phase points as shown in TABLE 1 and stored into memory. Once the waveform is stored into memory, it can be generated at very precise frequencies. The direct digital synthesis table may be stored in a non-volatile memory of the generator circuit and/or may be implemented with a FPGA circuit in the generator circuit. The lookup table **4210** may be addressed by any suitable technique that is convenient for categorizing wave shapes. According to one aspect, the lookup table **4210** is addressed according to a frequency of the electrical signal waveform. Additionally, the information associated with the plurality of wave shapes may be stored as digital information in a memory or as part of the lookup table **4210**.

[0549] In one aspect, the generator circuit may be configured to provide electrical signal waveforms to at least two surgical instruments simultaneously. The generator circuit also may be configured to provide the electrical signal waveform, which may be characterized two or more wave shapes, via an output channel of the generator circuit to the two surgical instruments simultaneously. For example, in one aspect the electrical signal waveform comprises a first electrical signal to drive an ultrasonic transducer (e.g., ultrasonic drive signal), a second RF drive signal, and/or a combination thereof. In addition, an electrical signal waveform may comprise a plurality of ultrasonic drive signals, a plurality of RF drive signals, and/or a combination of a plurality of ultrasonic and RF drive signals.

[0550] In addition, a method of operating the generator circuit according to the present disclosure comprises generating an electrical signal waveform and providing the generated electrical signal waveform to any one of the surgical instruments of surgical system **1000**, where generating the electrical signal waveform comprises receiving information associated with the electrical signal waveform from a memory. The generated electrical signal waveform comprises at least one wave shape. Furthermore, providing the generated electrical signal waveform to the at least one surgical instrument comprises providing the electrical signal waveform to at least two surgical instruments simultaneously.

[0551] The generator circuit as described herein may allow for the generation of various types of direct digital synthesis tables. Examples of wave shapes for RF/Electrosurgery signals suitable for treating a variety of tissue generated by the generator circuit include RF signals with a high crest factor (which may be used for surface coagulation in RF mode), a low crest factor RF signals (which may be used for deeper tissue penetration), and waveforms that promote efficient touch-up coagulation. The generator circuit also may generate multiple wave shapes employing a direct digital synthesis lookup table 4210 and, on the fly, can switch between particular wave shapes based on the desired tissue effect. Switching may be based on tissue impedance and/or other factors.

[0552] In addition to traditional sine/cosine wave shapes, the generator circuit may be configured to generate wave shape(s) that maximize the power into tissue per cycle (i.e., trapezoidal or square wave). The generator circuit may provide wave shape(s) that are synchronized to maximize the power delivered to the load when driving RF and ultrasonic signals simultaneously and to maintain ultrasonic frequency lock, provided that the generator circuit includes a circuit topology that enables simultaneously driving RF and ultrasonic signals. Further, custom wave shapes specific to instruments and their tissue effects can be stored in a non-volatile memory (NVM) or an instrument EEPROM and can be fetched upon connecting any one of the surgical instruments of surgical system 1000 to the generator circuit.

[0553] The DDS circuit 4200 may comprise multiple lookup tables 4104 where the lookup table 4210 stores a waveform represented by a predetermined number of phase points (also may be referred to as samples), wherein the phase points define a predetermined shape of the waveform. Thus multiple waveforms having a unique shape can be stored in multiple lookup tables 4210 to provide different tissue treatments based on instrument settings or tissue feedback. Examples of waveforms include high crest factor RF electrical signal waveforms for surface tissue coagulation, low crest factor RF electrical signal waveform for deeper tissue penetration, and electrical signal waveforms that promote efficient touch-up coagulation. In one aspect, the DDS circuit 4200 can create multiple wave shape lookup tables 4210 and during a tissue treatment procedure (e.g., “on-the-fly” or in virtual real time based on user or sensor inputs) switch between different wave shapes stored in different lookup tables 4210 based on the tissue effect desired and/or tissue feedback.

[0554] Accordingly, switching between wave shapes can be based on tissue impedance and other factors, for example. In other aspects, the lookup tables 4210 can store electrical signal waveforms shaped to maximize the power delivered into the tissue per cycle (i.e., trapezoidal or square wave). In other aspects, the lookup tables 4210 can store wave shapes synchronized in such way that they make maximizing power delivery by any one of the surgical instruments of surgical system 1000 when delivering RF and ultrasonic drive signals. In yet other aspects, the lookup tables 4210 can store electrical signal waveforms to drive ultrasonic and RF therapeutic, and/or sub-therapeutic, energy simultaneously while maintaining ultrasonic frequency lock. Generally, the output wave shape may be in the form of a sine wave, cosine wave, pulse wave, square wave, and the like. Nevertheless, the more complex and custom wave shapes specific to different instruments and their tissue effects can be stored in

the non-volatile memory of the generator circuit or in the non-volatile memory (e.g., EEPROM) of the surgical instrument and be fetched upon connecting the surgical instrument to the generator circuit. One example of a custom wave shape is an exponentially damped sinusoid as used in many high crest factor “coagulation” waveforms, as shown in FIG. 43.

[0555] FIG. 43 illustrates one cycle of a discrete time digital electrical signal waveform 4300, in accordance with at least one aspect of the present disclosure of an analog waveform 4304 (shown superimposed over the discrete time digital electrical signal waveform 4300 for comparison purposes). The horizontal axis represents Time (t) and the vertical axis represents digital phase points. The digital electrical signal waveform 4300 is a digital discrete time version of the desired analog waveform 4304, for example. The digital electrical signal waveform 4300 is generated by storing an amplitude phase point 4302 that represents the amplitude per clock cycle T_{clk} over one cycle or period T_0 . The digital electrical signal waveform 4300 is generated over one period T_0 by any suitable digital processing circuit. The amplitude phase points are digital words stored in a memory circuit. In the example illustrated in FIGS. 41, 42, the digital word is a six-bit word that is capable of storing the amplitude phase points with a resolution of 26 or 64 bits. It will be appreciated that the examples shown in FIGS. 41, 42 is for illustrative purposes and in actual implementations the resolution can be much higher. The digital amplitude phase points 4302 over one cycle T_0 are stored in the memory as a string of string words in a lookup table 4104, 4210 as described in connection with FIGS. 41, 42, for example. To generate the analog version of the analog waveform 4304, the amplitude phase points 4302 are read sequentially from the memory from 0 to T_0 per clock cycle T_{clk} and are converted by a DAC circuit 4108, 4212, also described in connection with FIGS. 41, 42. Additional cycles can be generated by repeatedly reading the amplitude phase points 4302 of the digital electrical signal waveform 4300 the from 0 to T_0 for as many cycles or periods as may be desired. The smooth analog version of the analog waveform 4304 is achieved by filtering the output of the DAC circuit 4108, 4212 by a filter 4112, 4214 (FIGS. 41 and 42). The filtered analog output signal 4114, 4222 (FIGS. 41 and 42) is applied to the input of a power amplifier.

[0556] FIG. 44 is a diagram of a control system 12950 configured to provide progressive closure of a closure member (e.g., closure tube) when the displacement member advances distally and couples into a clamp arm (e.g., anvil) to lower the closure force load on the closure member at a desired rate and decrease the firing force load on the firing member according to one aspect of this disclosure. In one aspect, the control system 12950 may be implemented as a nested PID feedback controller. A PID controller is a control loop feedback mechanism (controller) to continuously calculate an error value as the difference between a desired set point and a measured process variable and applies a correction based on proportional, integral, and derivative terms (sometimes denoted P, I, and D respectively). The nested PID controller feedback control system 12950 includes a primary controller 12952, in a primary (outer) feedback loop 12954 and a secondary controller 12955 in a secondary (inner) feedback loop 12956. The primary controller 12952 may be a PID controller 12972 as shown in FIG. 45, and the secondary controller 12955 also may be a PID controller

12972 as shown in FIG. 45. The primary controller **12952** controls a primary process **12958** and the secondary controller **12955** controls a secondary process **12960**. The output **12966** of the primary process **12958** is subtracted from a primary set point SP_1 by a first summer **12962**. The first summer **12962** produces a single sum output signal which is applied to the primary controller **12952**. The output of the primary controller **12952** is the secondary set point SP_2 . The output **12968** of the secondary process **12960** is subtracted from the secondary set point SP_2 by a second summer **12964**.

[**0557**] In the context of controlling the displacement of a closure tube, the control system **12950** may be configured such that the primary set point SP_1 is a desired closure force value and the primary controller **12952** is configured to receive the closure force from a torque sensor coupled to the output of a closure motor and determine a set point SP_2 motor velocity for the closure motor. In other aspects, the closure force may be measured with strain gauges, load cells, or other suitable force sensors. The closure motor velocity set point SP_2 is compared to the actual velocity of the closure tube, which is determined by the secondary controller **12955**. The actual velocity of the closure tube may be measured by comparing measuring the displacement of the closure tube with the position sensor and measuring elapsed time with a timer/counter. Other techniques, such as linear or rotary encoders may be employed to measure displacement of the closure tube. The output **12968** of the secondary process **12960** is the actual velocity of the closure tube. This closure tube velocity output **12968** is provided to the primary process **12958** which determines the force acting on the closure tube and is fed back to the adder **12962**, which subtracts the measured closure force from the primary set point SP_1 . The primary set point SP_1 may be an upper threshold or a lower threshold. Based on the output of the adder **12962**, the primary controller **12952** controls the velocity and direction of the closure motor. The secondary controller **12955** controls the velocity of the closure motor based on the actual velocity of closure tube measured by the secondary process **12960** and the secondary set point SP_2 , which is based on a comparison of the actual firing force and the firing force upper and lower thresholds.

[**0558**] FIG. 45 illustrates a PID feedback control system **12970** according to one aspect of this disclosure. The primary controller **12952** or the secondary controller **12955**, or both, may be implemented as a PID controller **12972**. In one aspect, the PID controller **12972** may comprise a proportional element **12974** (P), an integral element **12976** (I), and a derivative element **12978** (D). The outputs of the P, I, D elements **12974**, **12976**, **12978** are summed by a summer **12986**, which provides the control variable $\mu(t)$ to the process **12980**. The output of the process **12980** is the process variable $y(t)$. A summer **12984** calculates the difference between a desired set point $r(t)$ and a measured process variable $y(t)$. The PID controller **12972** continuously calculates an error value $e(t)$ (e.g., difference between closure force threshold and measured closure force) as the difference between a desired set point $r(t)$ (e.g., closure force threshold) and a measured process variable $y(t)$ (e.g., velocity and direction of closure tube) and applies a correction based on the proportional, integral, and derivative terms calculated by the proportional element **12974** (P), integral element **12976** (I), and derivative element **12978** (D), respectively. The PID controller **12972** attempts to minimize

the error $e(t)$ over time by adjustment of the control variable $\mu(t)$ (e.g., velocity and direction of the closure tube).

[**0559**] In accordance with the PID algorithm, the “P” element **12974** accounts for present values of the error. For example, if the error is large and positive, the control output will also be large and positive. In accordance with the present disclosure, the error term $e(t)$ is the different between the desired closure force and the measured closure force of the closure tube. The “I” element **12976** accounts for past values of the error. For example, if the current output is not sufficiently strong, the integral of the error will accumulate over time, and the controller will respond by applying a stronger action. The “D” element **12978** accounts for possible future trends of the error, based on its current rate of change. For example, continuing the P example above, when the large positive control output succeeds in bringing the error closer to zero, it also puts the process on a path to large negative error in the near future. In this case, the derivative turns negative and the D module reduces the strength of the action to prevent this overshoot.

[**0560**] It will be appreciated that other variables and set points may be monitored and controlled in accordance with the feedback control systems **12950**, **12970**. For example, the adaptive closure member velocity control algorithm described herein may measure at least two of the following parameters: firing member stroke location, firing member load, displacement of cutting element, velocity of cutting element, closure tube stroke location, closure tube load, among others.

[**0561**] Ultrasonic surgical devices, such as ultrasonic scalpels, are finding increasingly widespread applications in surgical procedures by virtue of their unique performance characteristics. Depending upon specific device configurations and operational parameters, ultrasonic surgical devices can provide substantially simultaneous transection of tissue and homeostasis by coagulation, desirably minimizing patient trauma. An ultrasonic surgical device may comprise a handpiece containing an ultrasonic transducer, and an instrument coupled to the ultrasonic transducer having a distally-mounted end effector (e.g., a blade tip) to cut and seal tissue. In some cases, the instrument may be permanently affixed to the handpiece. In other cases, the instrument may be detachable from the handpiece, as in the case of a disposable instrument or an interchangeable instrument. The end effector transmits ultrasonic energy to tissue brought into contact with the end effector to realize cutting and sealing action. Ultrasonic surgical devices of this nature can be configured for open surgical use, laparoscopic, or endoscopic surgical procedures including robotic-assisted procedures.

[**0562**] Ultrasonic energy cuts and coagulates tissue using temperatures lower than those used in electrosurgical procedures and can be transmitted to the end effector by an ultrasonic generator in communication with the handpiece. Vibrating at high frequencies (e.g., 55,500 cycles per second), the ultrasonic blade denatures protein in the tissue to form a sticky coagulum. Pressure exerted on tissue by the blade surface collapses blood vessels and allows the coagulum to form a hemostatic seal. A surgeon can control the cutting speed and coagulation by the force applied to the tissue by the end effector, the time over which the force is applied, and the selected excursion level of the end effector.

[**0563**] The ultrasonic transducer may be modeled as an equivalent circuit comprising a first branch having a static

capacitance and a second “motional” branch having a serially connected inductance, resistance and capacitance that define the electromechanical properties of a resonator. Known ultrasonic generators may include a tuning inductor for tuning out the static capacitance at a resonant frequency so that substantially all of a generator’s drive signal current flows into the motional branch. Accordingly, by using a tuning inductor, the generator’s drive signal current represents the motional branch current, and the generator is thus able to control its drive signal to maintain the ultrasonic transducer’s resonant frequency. The tuning inductor may also transform the phase impedance plot of the ultrasonic transducer to improve the generator’s frequency lock capabilities. However, the tuning inductor must be matched with the specific static capacitance of an ultrasonic transducer at the operational resonant frequency. In other words, a different ultrasonic transducer having a different static capacitance requires a different tuning inductor.

[0564] Additionally, in some ultrasonic generator architectures, the generator’s drive signal exhibits asymmetrical harmonic distortion that complicates impedance magnitude and phase measurements. For example, the accuracy of impedance phase measurements may be reduced due to harmonic distortion in the current and voltage signals.

[0565] Moreover, electromagnetic interference in noisy environments decreases the ability of the generator to maintain lock on the ultrasonic transducer’s resonant frequency, increasing the likelihood of invalid control algorithm inputs.

[0566] Electrosurgical devices for applying electrical energy to tissue in order to treat and/or destroy the tissue are also finding increasingly widespread applications in surgical procedures. An electrosurgical device may comprise a handpiece and an instrument having a distally-mounted end effector (e.g., one or more electrodes). The end effector can be positioned against the tissue such that electrical current is introduced into the tissue. Electrosurgical devices can be configured for bipolar or monopolar operation. During bipolar operation, current is introduced into and returned from the tissue by active and return electrodes, respectively, of the end effector. During monopolar operation, current is introduced into the tissue by an active electrode of the end effector and returned through a return electrode (e.g., a grounding pad) separately located on a patient’s body. Heat generated by the current flowing through the tissue may form hemostatic seals within the tissue and/or between tissues and thus may be particularly useful for sealing blood vessels, for example. The end effector of an electrosurgical device may also comprise a cutting member that is movable relative to the tissue and the electrodes to transect the tissue.

[0567] Electrical energy applied by an electrosurgical device can be transmitted to the instrument by a generator in communication with the handpiece. The electrical energy may be in the form of radio frequency (RF) energy. RF energy is a form of electrical energy that may be in the frequency range of 300 kHz to 1 MHz, as described in EN60601-2-2:2009+A11:2011, Definition 201.3.218—HIGH FREQUENCY. For example, the frequencies in monopolar RF applications are typically restricted to less than 5 MHz. However, in bipolar RF applications, the frequency can be almost any value. Frequencies above 200 kHz are typically used for monopolar applications in order to avoid the unwanted stimulation of nerves and muscles which would result from the use of low frequency current. Lower frequencies may be used for bipolar techniques if a

risk analysis shows the possibility of neuromuscular stimulation has been mitigated to an acceptable level. Normally, frequencies above 5 MHz are not used in order to minimize the problems associated with high frequency leakage currents. It is generally recognized that 10 mA is the lower threshold of thermal effects on tissue.

[0568] During its operation, an electrosurgical device can transmit low frequency RF energy through tissue, which causes ionic agitation, or friction, in effect resistive heating, thereby increasing the temperature of the tissue. Because a sharp boundary may be created between the affected tissue and the surrounding tissue, surgeons can operate with a high level of precision and control, without sacrificing un-targeted adjacent tissue. The low operating temperatures of RF energy may be useful for removing, shrinking, or sculpting soft tissue while simultaneously sealing blood vessels. RF energy may work particularly well on connective tissue, which is primarily comprised of collagen and shrinks when contacted by heat.

[0569] Due to their unique drive signal, sensing and feedback needs, ultrasonic and electrosurgical devices have generally required different generators. Additionally, in cases where the instrument is disposable or interchangeable with a handpiece, ultrasonic and electrosurgical generators are limited in their ability to recognize the particular instrument configuration being used and to optimize control and diagnostic processes accordingly. Moreover, capacitive coupling between the non-isolated and patient-isolated circuits of the generator, especially in cases where higher voltages and frequencies are used, may result in exposure of a patient to unacceptable levels of leakage current.

[0570] Furthermore, due to their unique drive signal, sensing and feedback needs, ultrasonic and electrosurgical devices have generally required different user interfaces for the different generators. In such conventional ultrasonic and electrosurgical devices, one user interface is configured for use with an ultrasonic instrument whereas a different user interface may be configured for use with an electrosurgical instrument. Such user interfaces include hand and/or foot activated user interfaces such as hand activated switches and/or foot activated switches. As various aspects of combined generators for use with both ultrasonic and electrosurgical instruments are contemplated in the subsequent disclosure, additional user interfaces that are configured to operate with both ultrasonic and/or electrosurgical instrument generators also are contemplated.

[0571] Additional user interfaces for providing feedback, whether to the user or other machine, are contemplated within the subsequent disclosure to provide feedback indicating an operating mode or status of either an ultrasonic and/or electrosurgical instrument. Providing user and/or machine feedback for operating a combination ultrasonic and/or electrosurgical instrument will require providing sensory feedback to a user and electrical/mechanical/electromechanical feedback to a machine. Feedback devices that incorporate visual feedback devices (e.g., an LCD display screen, LED indicators), audio feedback devices (e.g., a speaker, a buzzer) or tactile feedback devices (e.g., haptic actuators) for use in combined ultrasonic and/or electrosurgical instruments are contemplated in the subsequent disclosure.

[0572] Other electrical surgical instruments include, without limitation, irreversible and/or reversible electroporation, and/or microwave technologies, among others. Accordingly,

the techniques disclosed herein are applicable to ultrasonic, bipolar or monopolar RF (electrosurgical), irreversible and/or reversible electroporation, and/or microwave based surgical instruments, among others.

[0573] Various aspects are directed to improved ultrasonic surgical devices, electrosurgical devices and generators for use therewith. Aspects of the ultrasonic surgical devices can be configured for transecting and/or coagulating tissue during surgical procedures, for example. Aspects of the electrosurgical devices can be configured for transecting, coagulating, scaling, welding and/or desiccating tissue during surgical procedures, for example.

[0574] Aspects of the generator utilize high-speed analog-to-digital sampling (e.g., approximately 200× oversampling, depending on frequency) of the generator drive signal current and voltage, along with digital signal processing, to provide a number of advantages and benefits over known generator architectures. In one aspect, for example, based on current and voltage feedback data, a value of the ultrasonic transducer static capacitance, and a value of the drive signal frequency, the generator may determine the motional branch current of an ultrasonic transducer. This provides the benefit of a virtually tuned system, and simulates the presence of a system that is tuned or resonant with any value of the static capacitance (e.g., C_0 in FIG. 25) at any frequency. Accordingly, control of the motional branch current may be realized by tuning out the effects of the static capacitance without the need for a tuning inductor. Additionally, the elimination of the tuning inductor may not degrade the generator's frequency lock capabilities, as frequency lock can be realized by suitably processing the current and voltage feedback data.

[0575] High-speed analog-to-digital sampling of the generator drive signal current and voltage, along with digital signal processing, may also enable precise digital filtering of the samples. For example, aspects of the generator may utilize a low-pass digital filter (e.g., a finite impulse response (FIR) filter) that rolls off between a fundamental drive signal frequency and a second-order harmonic to reduce the asymmetrical harmonic distortion and EMI-induced noise in current and voltage feedback samples. The filtered current and voltage feedback samples represent substantially the fundamental drive signal frequency, thus enabling a more accurate impedance phase measurement with respect to the fundamental drive signal frequency and an improvement in the generator's ability to maintain resonant frequency lock. The accuracy of the impedance phase measurement may be further enhanced by averaging falling edge and rising edge phase measurements, and by regulating the measured impedance phase to 0°.

[0576] Various aspects of the generator may also utilize the high-speed analog-to-digital sampling of the generator drive signal current and voltage, along with digital signal processing, to determine real power consumption and other quantities with a high degree of precision. This may allow the generator to implement a number of useful algorithms, such as, for example, controlling the amount of power delivered to tissue as the impedance of the tissue changes and controlling the power delivery to maintain a constant rate of tissue impedance increase. Some of these algorithms are used to determine the phase difference between the generator drive signal current and voltage signals. At resonance, the phase difference between the current and voltage signals is zero. The phase changes as the ultrasonic system

goes off-resonance. Various algorithms may be employed to detect the phase difference and adjust the drive frequency until the ultrasonic system returns to resonance, i.e., the phase difference between the current and voltage signals goes to zero. The phase information also may be used to infer the conditions of the ultrasonic blade. As discussed with particularity below, the phase changes as a function of the temperature of the ultrasonic blade. Therefore, the phase information may be employed to control the temperature of the ultrasonic blade. This may be done, for example, by reducing the power delivered to the ultrasonic blade when the ultrasonic blade runs too hot and increasing the power delivered to the ultrasonic blade when the ultrasonic blade runs too cold.

[0577] Various aspects of the generator may have a wide frequency range and increased output power necessary to drive both ultrasonic surgical devices and electrosurgical devices. The lower voltage, higher current demand of electrosurgical devices may be met by a dedicated tap on a wideband power transformer, thereby eliminating the need for a separate power amplifier and output transformer. Moreover, sensing and feedback circuits of the generator may support a large dynamic range that addresses the needs of both ultrasonic and electrosurgical applications with minimal distortion.

[0578] Various aspects may provide a simple, economical means for the generator to read from, and optionally write to, a data circuit (e.g., a single-wire bus device, such as a one-wire protocol EEPROM known under the trade name "1-Wire") disposed in an instrument attached to the handpiece using existing multi-conductor generator/handpiece cables. In this way, the generator is able to retrieve and process instrument-specific data from an instrument attached to the handpiece. This may enable the generator to provide better control and improved diagnostics and error detection. Additionally, the ability of the generator to write data to the instrument makes possible new functionality in terms of, for example, tracking instrument usage and capturing operational data. Moreover, the use of frequency band permits the backward compatibility of instruments containing a bus device with existing generators.

[0579] Disclosed aspects of the generator provide active cancellation of leakage current caused by unintended capacitive coupling between non-isolated and patient-isolated circuits of the generator. In addition to reducing patient risk, the reduction of leakage current may also lessen electromagnetic emissions.

[0580] These and other benefits of aspects of the present disclosure will be apparent from the description to follow.

[0581] It will be appreciated that the terms "proximal" and "distal" are used herein with reference to a clinician gripping a handpiece. Thus, an end effector is distal with respect to the more proximal handpiece. It will be further appreciated that, for convenience and clarity, spatial terms such as "top" and "bottom" may also be used herein with respect to the clinician gripping the handpiece. However, surgical devices are used in many orientations and positions, and these terms are not intended to be limiting and absolute.

[0582] FIG. 46 is an elevational exploded view of modular handheld ultrasonic surgical instrument 6480 showing the left shell half removed from a handle assembly 6482 exposing a device identifier communicatively coupled to the multi-lead handle terminal assembly in accordance with one aspect of the present disclosure. In additional aspects of the

present disclosure, an intelligent or smart battery is used to power the modular handheld ultrasonic surgical instrument **6480**. However, the smart battery is not limited to the modular handheld ultrasonic surgical instrument **6480** and, as will be explained, can be used in a variety of devices, which may or may not have power requirements (e.g., current and voltage) that vary from one another. The smart battery assembly **6486**, in accordance with one aspect of the present disclosure, is advantageously able to identify the particular device to which it is electrically coupled. It does this through encrypted or unencrypted identification methods. For instance, a smart battery assembly **6486** can have a connection portion, such as connection portion **6488**. The handle assembly **6482** can also be provided with a device identifier communicatively coupled to the multi-lead handle terminal assembly **6491** and operable to communicate at least one piece of information about the handle assembly **6482**. This information can pertain to the number of times the handle assembly **6482** has been used, the number of times an ultrasonic transducer/generator assembly **6484** (presently disconnected from the handle assembly **6482**) has been used, the number of times a waveguide shaft assembly **6490** (presently connected to the handle assembly **6482**) has been used, the type of the waveguide shaft assembly **6490** that is presently connected to the handle assembly **6482**, the type or identity of the ultrasonic transducer/generator assembly **6484** that is presently connected to the handle assembly **6482**, and/or many other characteristics. When the smart battery assembly **6486** is inserted in the handle assembly **6482**, the connection portion **6488** within the smart battery assembly **6486** makes communicating contact with the device identifier of the handle assembly **6482**. The handle assembly **6482**, through hardware, software, or a combination thereof, is able to transmit information to the smart battery assembly **6486** (whether by self-initiation or in response to a request from the smart battery assembly **6486**). This communicated identifier is received by the connection portion **6488** of the smart battery assembly **6486**. In one aspect, once the smart battery assembly **6486** receives the information, the communication portion is operable to control the output of the smart battery assembly **6486** to comply with the device's specific power requirements.

[0583] In one aspect, the communication portion includes a processor **6493** and a memory **6497**, which may be separate or a single component. The processor **6493**, in combination with the memory, is able to provide intelligent power management for the modular handheld ultrasonic surgical instrument **6480**. This aspect is particularly advantageous because an ultrasonic device, such as the modular handheld ultrasonic surgical instrument **6480**, has a power requirement (frequency, current, and voltage) that may be unique to the modular handheld ultrasonic surgical instrument **6480**. In fact, the modular handheld ultrasonic surgical instrument **6480** may have a particular power requirement or limitation for one dimension or type of outer tube **6494** and a second different power requirement for a second type of waveguide having a different dimension, shape, and/or configuration.

[0584] A smart battery assembly **6486**, in accordance with at least one aspect of the present disclosure, therefore, allows a battery assembly to be used amongst several surgical instruments. Because the smart battery assembly **6486** is able to identify to which device it is attached and is able to alter its output accordingly, the operators of various

different surgical instruments utilizing the smart battery assembly **6486** no longer need be concerned about which power source they are attempting to install within the electronic device being used. This is particularly advantageous in an operating environment where a battery assembly needs to be replaced or interchanged with another surgical instrument in the middle of a complex surgical procedure.

[0585] In a further aspect of the present disclosure, the smart battery assembly **6486** stores in a memory **6497** a record of each time a particular device is used. This record can be useful for assessing the end of a device's useful or permitted life. For instance, once a device is used 20 times, such batteries in the smart battery assembly **6486** connected to the device will refuse to supply power thereto—because the device is defined as a “no longer reliable” surgical instrument. Reliability is determined based on a number of factors. One factor can be wear, which can be estimated in a number of ways including the number of times the device has been used or activated. After a certain number of uses, the parts of the device can become worn and tolerances between parts exceeded. For instance, the smart battery assembly **6486** can sense the number of button pushes received by the handle assembly **6482** and can determine when a maximum number of button pushes has been met or exceeded. The smart battery assembly **6486** can also monitor an impedance of the button mechanism which can change, for instance, if the handle gets contaminated, for example, with saline.

[0586] This wear can lead to an unacceptable failure during a procedure. In some aspects, the smart battery assembly **6486** can recognize which parts are combined together in a device and even how many uses a part has experienced. For instance, if the smart battery assembly **6486** is a smart battery according to the present disclosure, it can identify the handle assembly **6482**, the waveguide shaft assembly **6490**, as well as the ultrasonic transducer/generator assembly **6484**, well before the user attempts use of the composite device. The memory **6497** within the smart battery assembly **6486** can, for example, record a time when the ultrasonic transducer/generator assembly **6484** is operated, and how, when, and for how long it is operated. If the ultrasonic transducer/generator assembly **6484** has an individual identifier, the smart battery assembly **6486** can keep track of uses of the ultrasonic transducer/generator assembly **6484** and refuse to supply power to that the ultrasonic transducer/generator assembly **6484** once the handle assembly **6482** or the ultrasonic transducer/generator assembly **6484** exceeds its maximum number of uses. The ultrasonic transducer/generator assembly **6484**, the handle assembly **6482**, the waveguide shaft assembly **6490**, or other components can include a memory chip that records this information as well. In this way, any number of smart batteries in the smart battery assembly **6486** can be used with any number of ultrasonic transducer/generator assemblies **6484**, staplers, vessel sealers, etc. and still be able to determine the total number of uses, or the total time of use (through use of the clock), or the total number of actuations, etc. of the ultrasonic transducer/generator assembly **6484**, the stapler, the vessel sealer, etc. or charge or discharge cycles. Smart functionality may reside outside the battery assembly **6486** and may reside in the handle assembly **6482**, the ultrasonic transducer/generator assembly **6484**, and/or the shaft assembly **6490**, for example.

[0587] When counting uses of the ultrasonic transducer/generator assembly 6484, to intelligently terminate the life of the ultrasonic transducer/generator assembly 6484, the surgical instrument accurately distinguishes between completion of an actual use of the ultrasonic transducer/generator assembly 6484 in a surgical procedure and a momentary lapse in actuation of the ultrasonic transducer/generator assembly 6484 due to, for example, a battery change or a temporary delay in the surgical procedure. Therefore, as an alternative to simply counting the number of activations of the ultrasonic transducer/generator assembly 6484, a real-time clock (RTC) circuit can be implemented to keep track of the amount of time the ultrasonic transducer/generator assembly 6484 actually is shut down. From the length of time measured, it can be determined through appropriate logic if the shutdown was significant enough to be considered the end of one actual use or if the shutdown was too short in time to be considered the end of one use. Thus, in some applications, this method may be a more accurate determination of the useful life of the ultrasonic transducer/generator assembly 6484 than a simple “activations-based” algorithm, which for example, may provide that ten “activations” occur in a surgical procedure and, therefore, ten activations should indicate that the counter is incremented by one. Generally, this type and system of internal clocking will prevent misuse of the device that is designed to deceive a simple “activations-based” algorithm and will prevent incorrect logging of a complete use in instances when there was only a simple de-mating of the ultrasonic transducer/generator assembly 6484 or the smart battery assembly 6486 that was required for legitimate reasons.

[0588] Although the ultrasonic transducer/generator assemblies 6484 of the surgical instrument 6480 are reusable, in one aspect a finite number of uses may be set because the surgical instrument 6480 is subjected to harsh conditions during cleaning and sterilization. More specifically, the battery pack is configured to be sterilized. Regardless of the material employed for the outer surfaces, there is a limited expected life for the actual materials used. This life is determined by various characteristics which could include, for example, the amount of times the pack has actually been sterilized, the time from which the pack was manufactured, and the number of times the pack has been recharged, to name a few. Also, the life of the battery cells themselves is limited. Software of the present disclosure incorporates inventive algorithms that verify the number of uses of the ultrasonic transducer/generator assembly 6484 and smart battery assembly 6486 and disables the device when this number of uses has been reached or exceeded. Analysis of the battery pack exterior in each of the possible sterilizing methods can be performed. Based on the harshest sterilization procedure, a maximum number of permitted sterilizations can be defined and that number can be stored in a memory of the smart battery assembly 6486. If it is assumed that a charger is non-sterile and that the smart battery assembly 6486 is to be used after it is charged, then the charge count can be defined as being equal to the number of sterilizations encountered by that particular pack.

[0589] In one aspect, the hardware in the battery pack may be disabled to minimize or eliminate safety concerns due to continuous drain in from the battery cells after the pack has been disabled by software. A situation can exist where the battery's internal hardware is incapable of disabling the

battery under certain low voltage conditions. In such a situation, in an aspect, the charger can be used to “kill” the battery. Due to the fact that the battery microcontroller is OFF while the battery is in its charger, a non-volatile, System Management Bus (SMB) based electrically erasable programmable read only memory (EEPROM) can be used to exchange information between the battery microcontroller and the charger. Thus, a serial EEPROM can be used to store information that can be written and read even when the battery microcontroller is OFF, which is very beneficial when trying to exchange information with the charger or other peripheral devices. This example EEPROM can be configured to contain enough memory registers to store at least (a) a use-count limit at which point the battery should be disabled (Battery Use Count), (b) the number of procedures the battery has undergone (Battery Procedure Count), and/or (c) a number of charges the battery has undergone (Charge Count), to name a few. Some of the information stored in the EEPROM, such as the Use Count Register and Charge Count Register are stored in write-protected sections of the EEPROM to prevent users from altering the information. In an aspect, the use and counters are stored with corresponding bit-inverted minor registers to detect data corruption.

[0590] Any residual voltage in the SMBus lines could damage the microcontroller and corrupt the SMBus signal. Therefore, to ensure that the SM Bus lines of a battery controller do not carry a voltage while the microcontroller is OFF, relays are provided between the external SMBus lines and the battery microcontroller board.

[0591] During charging of the smart battery assembly 6486, an “end-of-charge” condition of the batteries within the smart battery assembly 6486 is determined when, for example, the current flowing into the battery falls below a given threshold in a tapering manner when employing a constant-current/constant-voltage charging scheme. To accurately detect this “end-of-charge” condition, the battery microcontroller and buck boards are powered down and turned OFF during charging of the battery to reduce any current drain that may be caused by the boards and that may interfere with the tapering current detection. Additionally, the microcontroller and buck boards are powered down during charging to prevent any resulting corruption of the SMBus signal.

[0592] With regard to the charger, in one aspect the smart battery assembly 6486 is prevented from being inserted into the charger in any way other than the correct insertion position. Accordingly, the exterior of the smart battery assembly 6486 is provided with charger-holding features. A cup for holding the smart battery assembly 6486 securely in the charger is configured with a contour-matching taper geometry to prevent the accidental insertion of the smart battery assembly 6486 in any way other than the correct (intended) way. It is further contemplated that the presence of the smart battery assembly 6486 may be detectable by the charger itself. For example, the charger may be configured to detect the presence of the SMBus transmission from the battery protection circuit, as well as resistors that are located in the protection board. In such case, the charger would be enabled to control the voltage that is exposed at the charger's pins until the smart battery assembly 6486 is correctly seated or in place at the charger. This is because an exposed voltage at the charger's pins would present a hazard and a risk that

an electrical short could occur across the pins and cause the charger to inadvertently begin charging.

[0593] In some aspects, the smart battery assembly **6486** can communicate to the user through audio and/or visual feedback. For example, the smart battery assembly **6486** can cause the LEDs to light in a pre-set way. In such a case, even though the microcontroller in the ultrasonic transducer/generator assembly **6484** controls the LEDs, the microcontroller receives instructions to be carried out directly from the smart battery assembly **6486**.

[0594] In yet a further aspect of the present disclosure, the microcontroller in the ultrasonic transducer/generator assembly **6484**, when not in use for a predetermined period of time, goes into a sleep mode. Advantageously, when in the sleep mode, the clock speed of the microcontroller is reduced, cutting the current drain significantly. Some current continues to be consumed because the processor continues pinging waiting to sense an input. Advantageously, when the microcontroller is in this power-saving sleep mode, the microcontroller and the battery controller can directly control the LEDs. For example, a decoder circuit could be built into the ultrasonic transducer/generator assembly **6484** and connected to the communication lines such that the LEDs can be controlled independently by the processor **6493** while the ultrasonic transducer/generator assembly **6484** microcontroller is "OFF" or in a "sleep mode." This is a power-saving feature that eliminates the need for waking up the microcontroller in the ultrasonic transducer/generator assembly **6484**. Power is conserved by allowing the generator to be turned off while still being able to actively control the user-interface indicators.

[0595] Another aspect slows down one or more of the microcontrollers to conserve power when not in use. For example, the clock frequencies of both microcontrollers can be reduced to save power. To maintain synchronized operation, the microcontrollers coordinate the changing of their respective clock frequencies to occur at about the same time, both the reduction and, then, the subsequent increase in frequency when full speed operation is required. For example, when entering the idle mode, the clock frequencies are decreased and, when exiting the idle mode, the frequencies are increased.

[0596] In an additional aspect, the smart battery assembly **6486** is able to determine the amount of usable power left within its cells and is programmed to only operate the surgical instrument to which it is attached if it determines there is enough battery power remaining to predictably operate the device throughout the anticipated procedure. For example, the smart battery assembly **6486** is able to remain in a non-operational state if there is not enough power within the cells to operate the surgical instrument for 20 seconds. According to one aspect, the smart battery assembly **6486** determines the amount of power remaining within the cells at the end of its most recent preceding function, e.g., a surgical cutting. In this aspect, therefore, the smart battery assembly **6486** would not allow a subsequent function to be carried out if, for example, during that procedure, it determines that the cells have insufficient power. Alternatively, if the smart battery assembly **6486** determines that there is sufficient power for a subsequent procedure and goes below that threshold during the procedure, it would not interrupt the ongoing procedure and, instead, will allow it to finish and thereafter prevent additional procedures from occurring.

[0597] The following explains an advantage to maximizing use of the device with the smart battery assembly **6486** of the present disclosure. In this example, a set of different devices have different ultrasonic transmission waveguides. By definition, the waveguides could have a respective maximum allowable power limit where exceeding that power limit overstresses the waveguide and eventually causes it to fracture. One waveguide from the set of waveguides will naturally have the smallest maximum power tolerance. Because prior-art batteries lack intelligent battery power management, the output of prior-art batteries must be limited by a value of the smallest maximum allowable power input for the smallest/thinnest/most-frail waveguide in the set that is envisioned to be used with the device/battery. This would be true even though larger, thicker waveguides could later be attached to that handle and, by definition, allow a greater force to be applied. This limitation is also true for maximum battery power. For example, if one battery is designed to be used in multiple devices, its maximum output power will be limited to the lowest maximum power rating of any of the devices in which it is to be used. With such a configuration, one or more devices or device configurations would not be able to maximize use of the battery because the battery does not know the particular device's specific limits.

[0598] In one aspect, the smart battery assembly **6486** may be employed to intelligently circumvent the above-mentioned ultrasonic device limitations. The smart battery assembly **6486** can produce one output for one device or a particular device configuration and the same smart battery assembly **6486** can later produce a different output for a second device or device configuration. This universal smart battery surgical system lends itself well to the modern operating room where space and time are at a premium. By having a smart battery pack operate many different devices, the nurses can easily manage the storage, retrieval, and inventory of these packs. Advantageously, in one aspect the smart battery system according to the present disclosure may employ one type of charging station, thus increasing ease and efficiency of use and decreasing cost of surgical room charging equipment.

[0599] In addition, other surgical instruments, such as an electric stapler, may have a different power requirement than that of the modular handheld ultrasonic surgical instrument **6480**. In accordance with various aspects of the present disclosure, a smart battery assembly **6486** can be used with any one of a series of surgical instruments and can be made to tailor its own power output to the particular device in which it is installed. In one aspect, this power tailoring is performed by controlling the duty cycle of a switched mode power supply, such as buck, buck-boost, boost, or other configuration, integral with or otherwise coupled to and controlled by the smart battery assembly **6486**. In other aspects, the smart battery assembly **6486** can dynamically change its power output during device operation. For instance, in vessel sealing devices, power management provides improved tissue sealing. In these devices, large constant current values are needed. The total power output needs to be adjusted dynamically because, as the tissue is sealed, its impedance changes. Aspects of the present disclosure provide the smart battery assembly **6486** with a variable maximum current limit. The current limit can vary from one application (or device) to another, based on the requirements of the application or device.

[0600] FIG. 47 is a detail view of a trigger 6483 portion and switch of the ultrasonic surgical instrument 6480 shown in FIG. 46, in accordance with at least one aspect of the present disclosure. The trigger 6483 is operably coupled to the jaw member 6495 of the end effector 6492. The ultrasonic blade 6496 is energized by the ultrasonic transducer/generator assembly 6484 upon activating the activation switch 6485. Continuing now with FIG. 46 and also looking to FIG. 47, the trigger 6483 and the activation switch 6485 are shown as components of the handle assembly 6482. The trigger 6483 activates the end effector 6492, which has a cooperative association with the ultrasonic blade 6496 of the waveguide shaft assembly 6490 to enable various kinds of contact between the end effector jaw member 6495 and the ultrasonic blade 6496 with tissue and/or other substances. The jaw member 6495 of the end effector 6492 is usually a pivoting jaw that acts to grasp or clamp onto tissue disposed between the jaw and the ultrasonic blade 6496. In one aspect, an audible feedback is provided in the trigger that clicks when the trigger is fully depressed. The noise can be generated by a thin metal part that the trigger snaps over while closing. This feature adds an audible component to user feedback that informs the user that the jaw is fully compressed against the waveguide and that sufficient clamping pressure is being applied to accomplish vessel sealing. In another aspect, force sensors such as strain gages or pressure sensors may be coupled to the trigger 6483 to measure the force applied to the trigger 6483 by the user. In another aspect, force sensors such as strain gages or pressure sensors may be coupled to the switch 6485 button such that displacement intensity corresponds to the force applied by the user to the switch 6485 button.

[0601] The activation switch 6485, when depressed, places the modular handheld ultrasonic surgical instrument 6480 into an ultrasonic operating mode, which causes ultrasonic motion at the waveguide shaft assembly 6490. In one aspect, depression of the activation switch 6485 causes electrical contacts within a switch to close, thereby completing a circuit between the smart battery assembly 6486 and the ultrasonic transducer/generator assembly 6484 so that electrical power is applied to the ultrasonic transducer, as previously described. In another aspect, depression of the activation switch 6485 closes electrical contacts to the smart battery assembly 6486. Of course, the description of closing electrical contacts in a circuit is, here, merely an example general description of switch operation. There are many alternative aspects that can include opening contacts or processor-controlled power delivery that receives information from the switch and directs a corresponding circuit reaction based on the information.

[0602] FIG. 48 is a fragmentary, enlarged perspective view of an end effector 6492, in accordance with at least one aspect of the present disclosure, from a distal end with a jaw member 6495 in an open position. Referring to FIG. 48, a perspective partial view of the distal end 6498 of the waveguide shaft assembly 6490 is shown. The waveguide shaft assembly 6490 includes an outer tube 6494 surrounding a portion of the waveguide. The ultrasonic blade 6496 portion of the waveguide 6499 protrudes from the distal end 6498 of the outer tube 6494. It is the ultrasonic blade 6496 portion that contacts the tissue during a medical procedure and transfers its ultrasonic energy to the tissue. The waveguide shaft assembly 6490 also includes a jaw member 6495 that is coupled to the outer tube 6494 and an inner tube (not

visible in this view). The jaw member 6495, together with the inner and outer tubes and the ultrasonic blade 6496 portion of the waveguide 6499, can be referred to as an end effector 6492. As will be explained below, the outer tube 6494 and the non-illustrated inner tube slide longitudinally with respect to each other. As the relative movement between the outer tube 6494 and the non-illustrated inner tube occurs, the jaw member 6495 pivots upon a pivot point, thereby causing the jaw member 6495 to open and close. When closed, the jaw member 6495 imparts a pinching force on tissue located between the jaw member 6495 and the ultrasonic blade 6496, insuring positive and efficient blade-to-tissue contact.

[0603] FIG. 49 is a system diagram 7400 of a segmented circuit 7401 comprising a plurality of independently operated circuit segments 7402, 7414, 7416, 7420, 7424, 7428, 7434, 7440, in accordance with at least one aspect of the present disclosure. A circuit segment of the plurality of circuit segments of the segmented circuit 7401 comprises one or more circuits and one or more sets of machine executable instructions stored in one or more memory devices. The one or more circuits of a circuit segment are coupled to for electrical communication through one or more wired or wireless connection media. The plurality of circuit segments are configured to transition between three modes comprising a sleep mode, a standby mode and an operational mode.

[0604] In one aspect shown, the plurality of circuit segments 7402, 7414, 7416, 7420, 7424, 7428, 7434, 7440 start first in the standby mode, transition second to the sleep mode, and transition third to the operational mode. However, in other aspects, the plurality of circuit segments may transition from any one of the three modes to any other one of the three modes. For example, the plurality of circuit segments may transition directly from the standby mode to the operational mode. Individual circuit segments may be placed in a particular state by the voltage control circuit 7408 based on the execution by a processor of machine executable instructions. The states comprise a deenergized state, a low energy state, and an energized state. The deenergized state corresponds to the sleep mode, the low energy state corresponds to the standby mode, and the energized state corresponds to the operational mode. Transition to the low energy state may be achieved by, for example, the use of a potentiometer.

[0605] In one aspect, the plurality of circuit segments 7402, 7414, 7416, 7420, 7424, 7428, 7434, 7440 may transition from the sleep mode or the standby mode to the operational mode in accordance with an energization sequence. The plurality of circuit segments also may transition from the operational mode to the standby mode or the sleep mode in accordance with a deenergization sequence. The energization sequence and the deenergization sequence may be different. In some aspects, the energization sequence comprises energizing only a subset of circuit segments of the plurality of circuit segments. In some aspects, the deenergization sequence comprises deenergizing only a subset of circuit segments of the plurality of circuit segments.

[0606] Referring back to the system diagram 7400 in FIG. 49, the segmented circuit 7401 comprise a plurality of circuit segments comprising a transition circuit segment 7402, a processor circuit segment 7414, a handle circuit segment 7416, a communication circuit segment 7420, a display circuit segment 7424, a motor control circuit segment 7428,

an energy treatment circuit segment **7434**, and a shaft circuit segment **7440**. The transition circuit segment comprises a wake up circuit **7404**, a boost current circuit **7406**, a voltage control circuit **7408**, a safety controller **7410** and a POST controller **7412**. The transition circuit segment **7402** is configured to implement a deenergization and an energization sequence, a safety detection protocol, and a POST.

[**0607**] In some aspects, the wake up circuit **7404** comprises an accelerometer button sensor **7405**. In aspects, the transition circuit segment **7402** is configured to be in an energized state while other circuit segments of the plurality of circuit segments of the segmented circuit **7401** are configured to be in a low energy state, a deenergized state or an energized state. The accelerometer button sensor **7405** may monitor movement or acceleration of the surgical instrument **6480** described herein. For example, the movement may be a change in orientation or rotation of the surgical instrument. The surgical instrument may be moved in any direction relative to a three dimensional Euclidean space by for example, a user of the surgical instrument. When the accelerometer button sensor **7405** senses movement or acceleration, the accelerometer button sensor **7405** sends a signal to the voltage control circuit **7408** to cause the voltage control circuit **7408** to apply voltage to the processor circuit segment **7414** to transition the processor and a volatile memory to an energized state. In aspects, the processor and the volatile memory are in an energized state before the voltage control circuit **7409** applies voltage to the processor and the volatile memory. In the operational mode, the processor may initiate an energization sequence or a deenergization sequence. In various aspects, the accelerometer button sensor **7405** may also send a signal to the processor to cause the processor to initiate an energization sequence or a deenergization sequence. In some aspects, the processor initiates an energization sequence when the majority of individual circuit segments are in a low energy state or a deenergized state. In other aspects, the processor initiates a deenergization sequence when the majority of individual circuit segments are in an energized state.

[**0608**] Additionally or alternatively, the accelerometer button sensor **7405** may sense external movement within a predetermined vicinity of the surgical instrument. For example, the accelerometer button sensor **7405** may sense a user of the surgical instrument **6480** described herein moving a hand of the user within the predetermined vicinity. When the accelerometer button sensor **7405** senses this external movement, the accelerometer button sensor **7405** may send a signal to the voltage control circuit **7408** and a signal to the processor, as previously described. After receiving the sent signal, the processor may initiate an energization sequence or a deenergization sequence to transition one or more circuit segments between the three modes. In aspects, the signal sent to the voltage control circuit **7408** is sent to verify that the processor is in operational mode. In some aspects, the accelerometer button sensor **7405** may sense when the surgical instrument has been dropped and send a signal to the processor based on the sensed drop. For example, the signal can indicate an error in the operation of an individual circuit segment. One or more sensors may sense damage or malfunctioning of the affected individual circuit segments. Based on the sensed damage or malfunctioning, the POST controller **7412** may perform a POST of the corresponding individual circuit segments.

[**0609**] An energization sequence or a deenergization sequence may be defined based on the accelerometer button sensor **7405**. For example, the accelerometer button sensor **7405** may sense a particular motion or a sequence of motions that indicates the selection of a particular circuit segment of the plurality of circuit segments. Based on the sensed motion or series of sensed motions, the accelerometer button sensor **7405** may transmit a signal comprising an indication of one or more circuit segments of the plurality of circuit segments to the processor when the processor is in an energized state. Based on the signal, the processor determines an energization sequence comprising the selected one or more circuit segments. Additionally or alternatively, a user of the surgical instruments **6480** described herein may select a number and order of circuit segments to define an energization sequence or a deenergization sequence based on interaction with a graphical user interface (GUI) of the surgical instrument.

[**0610**] In various aspects, the accelerometer button sensor **7405** may send a signal to the voltage control circuit **7408** and a signal to the processor only when the accelerometer button sensor **7405** detects movement of the surgical instrument **6480** described herein or external movement within a predetermined vicinity above a predetermined threshold. For example, a signal may only be sent if movement is sensed for 5 or more seconds or if the surgical instrument is moved 5 or more inches. In other aspects, the accelerometer button sensor **7405** may send a signal to the voltage control circuit **7408** and a signal to the processor only when the accelerometer button sensor **7405** detects oscillating movement of the surgical instrument. A predetermined threshold reduces inadvertent transition of circuit segments of the surgical instrument. As previously described, the transition may comprise a transition to operational mode according to an energization sequence, a transition to low energy mode according to a deenergization sequence, or a transition to sleep mode according to a deenergization sequence. In some aspects, the surgical instrument comprises an actuator that may be actuated by a user of the surgical instrument. The actuation is sensed by the accelerometer button sensor **7405**. The actuator may be a slider, a toggle switch, or a momentary contact switch. Based on the sensed actuation, the accelerometer button sensor **7405** may send a signal to the voltage control circuit **7408** and a signal to the processor.

[**0611**] The boost current circuit **7406** is coupled to a battery. The boost current circuit **7406** is a current amplifier, such as a relay or transistor, and is configured to amplify the magnitude of a current of an individual circuit segment. The initial magnitude of the current corresponds to the source voltage provided by the battery to the segmented circuit **7401**. Suitable relays include solenoids. Suitable transistors include field-effect transistors (FET), MOSFET, and bipolar junction transistors (BJT). The boost current circuit **7406** may amplify the magnitude of the current corresponding to an individual circuit segment or circuit which requires more current draw during operation of the surgical instruments **6480** described herein. For example, an increase in current to the motor control circuit segment **7428** may be provided when a motor of the surgical instrument requires more input power. The increase in current provided to an individual circuit segment may cause a corresponding decrease in current of another circuit segment or circuit segments. Additionally or alternatively, the increase in current may correspond to voltage provided by an additional voltage source operating in conjunction with the battery.

[0612] The voltage control circuit 7408 is coupled to the battery. The voltage control circuit 7408 is configured to provide voltage to or remove voltage from the plurality of circuit segments. The voltage control circuit 7408 is also configured to increase or reduce voltage provided to the plurality of circuit segments of the segmented circuit 7401. In various aspects, the voltage control circuit 7408 comprises a combinational logic circuit such as a multiplexer (MUX) to select inputs, a plurality of electronic switches, and a plurality of voltage converters. An electronic switch of the plurality of electronic switches may be configured to switch between an open and closed configuration to disconnect or connect an individual circuit segment to or from the battery. The plurality of electronic switches may be solid state devices such as transistors or other types of switches such as wireless switches, ultrasonic switches, accelerometers, inertial sensors, among others. The combinational logic circuit is configured to select an individual electronic switch for switching to an open configuration to enable application of voltage to the corresponding circuit segment. The combination logic circuit also is configured to select an individual electronic switch for switching to a closed configuration to enable removal of voltage from the corresponding circuit segment. By selecting a plurality of individual electronic switches, the combination logic circuit may implement a deenergization sequence or an energization sequence. The plurality of voltage converters may provide a stepped-up voltage or a stepped-down voltage to the plurality of circuit segments. The voltage control circuit 7408 may also comprise a microprocessor and memory device.

[0613] The safety controller 7410 is configured to perform safety checks for the circuit segments. In some aspects, the safety controller 7410 performs the safety checks when one or more individual circuit segments are in the operational mode. The safety checks may be performed to determine whether there are any errors or defects in the functioning or operation of the circuit segments. The safety controller 7410 may monitor one or more parameters of the plurality of circuit segments. The safety controller 7410 may verify the identity and operation of the plurality of circuit segments by comparing the one or more parameters with predefined parameters. For example, if an RF energy modality is selected, the safety controller 7410 may verify that an articulation parameter of the shaft matches a predefined articulation parameter to verify the operation of the RF energy modality of the surgical instrument 6480 described herein. In some aspects, the safety controller 7410 may monitor, by the sensors, a predetermined relationship between one or more properties of the surgical instrument to detect a fault. A fault may arise when the one or more properties are inconsistent with the predetermined relationship. When the safety controller 7410 determines that a fault exists, an error exists, or that some operation of the plurality of circuit segments was not verified, the safety controller 7410 prevents or disables operation of the particular circuit segment where the fault, error or verification failure originated.

[0614] The POST controller 7412 performs a POST to verify proper operation of the plurality of circuit segments. In some aspects, the POST is performed for an individual circuit segment of the plurality of circuit segments prior to the voltage control circuit 7408 applying a voltage to the individual circuit segment to transition the individual circuit segment from standby mode or sleep mode to operational

mode. If the individual circuit segment does not pass the POST, the particular circuit segment does not transition from standby mode or sleep mode to operational mode. POST of the handle circuit segment 7416 may comprise, for example, testing whether the handle control sensors 7418 sense an actuation of a handle control of the surgical instrument 6480 described herein. In some aspects, the POST controller 7412 may transmit a signal to the accelerometer button sensor 7405 to verify the operation of the individual circuit segment as part of the POST. For example, after receiving the signal, the accelerometer button sensor 7405 may prompt a user of the surgical instrument to move the surgical instrument to a plurality of varying locations to confirm operation of the surgical instrument. The accelerometer button sensor 7405 may also monitor an output of a circuit segment or a circuit of a circuit segment as part of the POST. For example, the accelerometer button sensor 7405 can sense an incremental motor pulse generated by the motor 7432 to verify operation. A motor controller of the motor control circuit 7430 may be used to control the motor 7432 to generate the incremental motor pulse.

[0615] In various aspects, the surgical instrument 6480 described herein may comprise additional accelerometer button sensors. The POST controller 7412 may also execute a control program stored in the memory device of the voltage control circuit 7408. The control program may cause the POST controller 7412 to transmit a signal requesting a matching encrypted parameter from a plurality of circuit segments. Failure to receive a matching encrypted parameter from an individual circuit segment indicates to the POST controller 7412 that the corresponding circuit segment is damaged or malfunctioning. In some aspects, if the POST controller 7412 determines based on the POST that the processor is damaged or malfunctioning, the POST controller 7412 may send a signal to one or more secondary processors to cause one or more secondary processors to perform critical functions that the processor is unable to perform. In some aspects, if the POST controller 7412 determines based on the POST that one or more circuit segments do not operate properly, the POST controller 7412 may initiate a reduced performance mode of those circuit segments operating properly while locking out those circuit segments that fail POST or do not operate properly. A locked out circuit segment may function similarly to a circuit segment in standby mode or sleep mode.

[0616] The processor circuit segment 7414 comprises the processor and the volatile memory. The processor is configured to initiate an energization or a deenergization sequence. To initiate the energization sequence, the processor transmits an energizing signal to the voltage control circuit 7408 to cause the voltage control circuit 7408 to apply voltage to the plurality or a subset of the plurality of circuit segments in accordance with the energization sequence. To initiate the deenergization sequence, the processor transmits a deenergizing signal to the voltage control circuit 7408 to cause the voltage control circuit 7408 to remove voltage from the plurality or a subset of the plurality of circuit segments in accordance with the deenergization sequence.

[0617] The handle circuit segment 7416 comprises handle control sensors 7418. The handle control sensors 7418 may sense an actuation of one or more handle controls of the surgical instrument 6480 described herein. In various aspects, the one or more handle controls comprise a clamp

control, a release button, an articulation switch, an energy activation button, and/or any other suitable handle control. The user may activate the energy activation button to select between an RF energy mode, an ultrasonic energy mode or a combination RF and ultrasonic energy mode. The handle control sensors **7418** may also facilitate attaching a modular handle to the surgical instrument. For example, the handle control sensors **7418** may sense proper attachment of the modular handle to the surgical instrument and indicate the sensed attachment to a user of the surgical instrument. The LCD display **7426** may provide a graphical indication of the sensed attachment. In some aspects, the handle control sensors **7418** senses actuation of the one or more handle controls. Based on the sensed actuation, the processor may initiate either an energization sequence or a deenergization sequence.

[0618] The communication circuit segment **7420** comprises a communication circuit **7422**. The communication circuit **7422** comprises a communication interface to facilitate signal communication between the individual circuit segments of the plurality of circuit segments. In some aspects, the communication circuit **7422** provides a path for the modular components of the surgical instrument **6480** described herein to communicate electrically. For example, a modular shaft and a modular transducer, when attached together to the handle of the surgical instrument, can upload control programs to the handle through the communication circuit **7422**.

[0619] The display circuit segment **7424** comprises a LCD display **7426**. The LCD display **7426** may comprise a liquid crystal display screen, LED indicators, etc. In some aspects, the LCD display **7426** is an organic light-emitting diode (OLED) screen. A display may be placed on, embedded in, or located remotely from the surgical instrument **6480** described herein. For example, the display can be placed on the handle of the surgical instrument. The display is configured to provide sensory feedback to a user. In various aspects, the LCD display **7426** further comprises a backlight. In some aspects, the surgical instrument may also comprise audio feedback devices such as a speaker or a buzzer and tactile feedback devices such as a haptic actuator.

[0620] The motor control circuit segment **7428** comprises a motor control circuit **7430** coupled to a motor **7432**. The motor **7432** is coupled to the processor by a driver and a transistor, such as a FET. In various aspects, the motor control circuit **7430** comprises a motor current sensor in signal communication with the processor to provide a signal indicative of a measurement of the current draw of the motor to the processor. The processor transmits the signal to the display. The display receives the signal and displays the measurement of the current draw of the motor **7432**. The processor may use the signal, for example, to monitor that the current draw of the motor **7432** exists within an acceptable range, to compare the current draw to one or more parameters of the plurality of circuit segments, and to determine one or more parameters of a patient treatment site. In various aspects, the motor control circuit **7430** comprises a motor controller to control the operation of the motor. For example, the motor control circuit **7430** controls various motor parameters, such as by adjusting the velocity, torque and acceleration of the motor **7432**. The adjusting is done based on the current through the motor **7432** measured by the motor current sensor.

[0621] In various aspects, the motor control circuit **7430** comprises a force sensor to measure the force and torque generated by the motor **7432**. The motor **7432** is configured to actuate a mechanism of the surgical instruments **6480** described herein. For example, the motor **7432** is configured to control actuation of the shaft of the surgical instrument to realize clamping, rotation and articulation functionality. For example, the motor **7432** may actuate the shaft to realize a clamping motion with jaws of the surgical instrument. The motor controller may determine whether the material clamped by the jaws is tissue or metal. The motor controller may also determine the extent to which the jaws clamp the material. For example, the motor controller may determine how open or closed the jaws are based on the derivative of sensed motor current or motor voltage. In some aspects, the motor **7432** is configured to actuate the transducer to cause the transducer to apply torque to the handle or to control articulation of the surgical instrument. The motor current sensor may interact with the motor controller to set a motor current limit. When the current meets the predefined threshold limit, the motor controller initiates a corresponding change in a motor control operation. For example, exceeding the motor current limit causes the motor controller to reduce the current draw of the motor.

[0622] The energy treatment circuit segment **7434** comprises a RF amplifier and safety circuit **7436** and an ultrasonic signal generator circuit **7438** to implement the energy modular functionality of the surgical instrument **6480** described herein. In various aspects, the RF amplifier and safety circuit **7436** is configured to control the RF modality of the surgical instrument by generating an RF signal. The ultrasonic signal generator circuit **7438** is configured to control the ultrasonic energy modality by generating an ultrasonic signal. The RF amplifier and safety circuit **7436** and an ultrasonic signal generator circuit **7438** may operate in conjunction to control the combination RF and ultrasonic energy modality.

[0623] The shaft circuit segment **7440** comprises a shaft module controller **7442**, a modular control actuator **7444**, one or more end effector sensors **7446**, and a non volatile memory **7448**. The shaft module controller **7442** is configured to control a plurality of shaft modules comprising the control programs to be executed by the processor. The plurality of shaft modules implements a shaft modality, such as ultrasonic, combination ultrasonic and RF, RF I-blade, and RF-opposable jaw. The shaft module controller **7442** can select shaft modality by selecting the corresponding shaft module for the processor to execute. The modular control actuator **7444** is configured to actuate the shaft according to the selected shaft modality. After actuation is initiated, the shaft articulates the end effector according to the one or more parameters, routines or programs specific to the selected shaft modality and the selected end effector modality. The one or more end effector sensors **7446** located at the end effector may include force sensors, temperature sensors, current sensors or motion sensors. The one or more end effector sensors **7446** transmit data about one or more operations of the end effector, based on the energy modality implemented by the end effector. In various aspects, the energy modalities include an ultrasonic energy modality, a RF energy modality, or a combination of the ultrasonic energy modality and the RF energy modality. The non volatile memory **7448** stores the shaft control programs. A control program comprises one or more parameters, routines

or programs specific to the shaft. In various aspects, the non volatile memory 7448 may be an ROM, EPROM, EEPROM or flash memory. The non volatile memory 7448 stores the shaft modules corresponding to the selected shaft of the surgical instrument 6480 described herein in. The shaft modules may be changed or upgraded in the non volatile memory 7448 by the shaft module controller 7442, depending on the surgical instrument shaft to be used in operation. [0624] FIG. 50 is a schematic diagram of a circuit 7925 of various components of a surgical instrument with motor control functions, in accordance with at least one aspect of the present disclosure. In various aspects, the surgical instrument 6480 described herein may include a drive mechanism 7930 which is configured to drive shafts and/or gear components in order to perform the various operations associated with the surgical instrument 6480. In one aspect, the drive mechanism 7930 includes a rotation drivetrain 7932 configured to rotate an end effector, for example, about a longitudinal axis relative to handle housing. The drive mechanism 7930 further includes a closure drivetrain 7934 configured to close a jaw member to grasp tissue with the end effector. In addition, the drive mechanism 7930 includes a firing drive train 7936 configured to open and close a clamp arm portion of the end effector to grasp tissue with the end effector.

[0625] The drive mechanism 7930 includes a selector gearbox assembly 7938 that can be located in the handle assembly of the surgical instrument. Proximal to the selector gearbox assembly 7938 is a function selection module which includes a first motor 7942 that functions to selectively move gear elements within the selector gearbox assembly 7938 to selectively position one of the drivetrains 7932, 7934, 7936 into engagement with an input drive component of an optional second motor 7944 and motor drive circuit 7946 (shown in dashed line to indicate that the second motor 7944 and motor drive circuit 7946 are optional components).

[0626] Still referring to FIG. 50, the motors 7942, 7944 are coupled to motor control circuits 7946, 7948, respectively, which are configured to control the operation of the motors 7942, 7944 including the flow of electrical energy from a power source 7950 to the motors 7942, 7944. The power source 7950 may be a DC battery (e.g., rechargeable lead-based, nickel-based, lithium-ion based, battery etc.) or any other power source suitable for providing electrical energy to the surgical instrument.

[0627] The surgical instrument further includes a microcontroller 7952 (“controller”). In certain instances, the controller 7952 may include a microprocessor 7954 (“processor”) and one or more computer readable mediums or memory units 7956 (“memory”). In certain instances, the memory 7956 may store various program instructions, which when executed may cause the processor 7954 to perform a plurality of functions and/or calculations described herein. The power source 7950 can be configured to supply power to the controller 7952, for example.

[0628] The processor 7954 may be in communication with the motor control circuit 7946. In addition, the memory 7956 may store program instructions, which when executed by the processor 7954 in response to a user input 7958 or feedback elements 7960, may cause the motor control circuit 7946 to motivate the motor 7942 to generate at least one rotational motion to selectively move gear elements within the selector gearbox assembly 7938 to selectively position one of the drivetrains 7932, 7934, 7936 into engagement with the input

drive component of the second motor 7944. Furthermore, the processor 7954 can be in communication with the motor control circuit 7948. The memory 7956 also may store program instructions, which when executed by the processor 7954 in response to a user input 7958, may cause the motor control circuit 7948 to motivate the motor 7944 to generate at least one rotational motion to drive the drivetrain engaged with the input drive component of the second motor 7948, for example.

[0629] The controller 7952 and/or other controllers of the present disclosure may be implemented using integrated and/or discrete hardware elements, software elements, and/or a combination of both. Examples of integrated hardware elements may include processors, microprocessors, microcontrollers, integrated circuits, ASICs, PLDs, DSPs, FPGAs, logic gates, registers, semiconductor devices, chips, microchips, chip sets, microcontrollers, system on a chip (SoC), and/or single in-line package (SIP). Examples of discrete hardware elements may include circuits and/or circuit elements such as logic gates, field effect transistors, bipolar transistors, resistors, capacitors, inductors, and/or relays. In certain instances, the controller 7952 may include a hybrid circuit comprising discrete and integrated circuit elements or components on one or more substrates, for example.

[0630] In certain instances, the controller 7952 and/or other controllers of the present disclosure may be an LM 4F230H5QR, available from Texas Instruments, for example. In certain instances, the Texas Instruments LM4F230H5QR is an ARM Cortex-M4F Processor Core comprising on-chip memory of 256 KB single-cycle flash memory, or other non-volatile memory, up to 40 MHz, a prefetch buffer to improve performance above 40 MHz, a 32 KB single-cycle SRAM, internal ROM loaded with StellarisWare® software, 2 KB EEPROM, one or more PWM modules, one or more QEI analog, one or more 12-bit ADC with 12 analog input channels, among other features that are readily available. Other microcontrollers may be readily substituted for use with the present disclosure. Accordingly, the present disclosure should not be limited in this context.

[0631] In various instances, one or more of the various steps described herein can be performed by a finite state machine comprising either a combinational logic circuit or a sequential logic circuit, where either the combinational logic circuit or the sequential logic circuit is coupled to at least one memory circuit. The at least one memory circuit stores a current state of the finite state machine. The combinational or sequential logic circuit is configured to cause the finite state machine to the steps. The sequential logic circuit may be synchronous or asynchronous. In other instances, one or more of the various steps described herein can be performed by a circuit that includes a combination of the processor 7958 and the finite state machine, for example.

[0632] In various instances, it can be advantageous to be able to assess the state of the functionality of a surgical instrument to ensure its proper function. It is possible, for example, for the drive mechanism, as explained above, which is configured to include various motors, drivetrains, and/or gear components in order to perform the various operations of the surgical instrument, to wear out over time. This can occur through normal use, and in some instances the drive mechanism can wear out faster due to abuse conditions. In certain instances, a surgical instrument can be

configured to perform self-assessments to determine the state, e.g. health, of the drive mechanism and its various components.

[0633] For example, the self-assessment can be used to determine when the surgical instrument is capable of performing its function before a re-sterilization or when some of the components should be replaced and/or repaired. Assessment of the drive mechanism and its components, including but not limited to the rotation drivetrain 7932, the closure drivetrain 7934, and/or the firing drivetrain 7936, can be accomplished in a variety of ways. The magnitude of deviation from a predicted performance can be used to determine the likelihood of a sensed failure and the severity of such failure. Several metrics can be used including: Periodic analysis of repeatably predictable events, Peaks or drops that exceed an expected threshold, and width of the failure.

[0634] In various instances, a signature waveform of a properly functioning drive mechanism or one or more of its components can be employed to assess the state of the drive mechanism or the one or more of its components. One or more vibration sensors can be arranged with respect to a properly functioning drive mechanism or one or more of its components to record various vibrations that occur during operation of the properly functioning drive mechanism or the one or more of its components. The recorded vibrations can be employed to create the signature waveform. Future waveforms can be compared against the signature waveform to assess the state of the drive mechanism and its components.

[0635] Still referring to FIG. 50, the surgical instrument 7930 includes a drivetrain failure detection module 7962 configured to record and analyze one or more acoustic outputs of one or more of the drivetrains 7932, 7934, 7936. The processor 7954 can be in communication with or otherwise control the module 7962. As described below in greater detail, the module 7962 can be embodied as various means, such as circuitry, hardware, a computer program product comprising a computer readable medium (for example, the memory 7956) storing computer readable program instructions that are executable by a processing device (for example, the processor 7954), or some combination thereof. In some aspects, the processor 36 can include, or otherwise control the module 7962.

[0636] Turning now to FIG. 51, the end effector 8400 comprises RF data sensors 8406, 8408a, 8408b located on the jaw member 8402. The end effector 8400 comprises a jaw member 8402 and an ultrasonic blade 8404. The jaw member 8402 is shown clamping tissue 8410 located between the jaw member 8402 and the ultrasonic blade 8404. A first sensor 8406 is located in a center portion of the jaw member 8402. Second and third sensors 8408a, 8408b are located on lateral portions of the jaw member 8402. The sensors 8406, 8408a, 8408b are mounted or formed integrally with a flexible circuit 8412 (shown more particularly in FIG. 52) configured to be fixedly mounted to the jaw member 8402.

[0637] The end effector 8400 is an example end effector for a surgical instrument. The sensors 8406, 8408a, 8408b are electrically connected to a control circuit such as the control circuit 7400 (FIG. 63) via interface circuits. The sensors 8406, 8408a, 8408b are battery powered and the

signals generated by the sensors 8406, 8408a, 8408b are provided to analog and/or digital processing circuits of the control circuit.

[0638] In one aspect, the first sensor 8406 is a force sensor to measure a normal force F3 applied to the tissue 8410 by the jaw member 8402. The second and third sensors 8408a, 8408b include one or more elements to apply RF energy to the tissue 8410, measure tissue impedance, down force F1, transverse forces F2, and temperature, among other parameters. Electrodes 8409a, 8409b are electrically coupled to an energy source and apply RF energy to the tissue 8410. In one aspect, the first sensor 8406 and the second and third sensors 8408a, 8408b are strain gauges to measure force or force per unit area. It will be appreciated that the measurements of the down force F1, the lateral forces F2, and the normal force F3 may be readily converted to pressure by determining the surface area upon which the force sensors 8406, 8408a, 8408b are acting upon. Additionally, as described with particularity herein, the flexible circuit 8412 may comprise temperature sensors embedded in one or more layers of the flexible circuit 8412. The one or more temperature sensors may be arranged symmetrically or asymmetrically and provide tissue 8410 temperature feedback to control circuits of an ultrasonic drive circuit and an RF drive circuit.

[0639] FIG. 52 illustrates one aspect of the flexible circuit 8412 shown in FIG. 51 in which the sensors 8406, 8408a, 8408b may be mounted to or formed integrally therewith. The flexible circuit 8412 is configured to fixedly attach to the jaw member 8402. As shown particularly in FIG. 52, asymmetric temperature sensors 8414a, 8414b are mounted to the flexible circuit 8412 to enable measuring the temperature of the tissue 8410 (FIG. 51).

[0640] FIG. 53 is an alternative system 132000 for controlling the frequency of an ultrasonic electromechanical system 132002 and detecting the impedance thereof, in accordance with at least one aspect of the present disclosure. The system 132000 may be incorporated into a generator. A processor 132004 coupled to a memory 132026 programs a programmable counter 132006 to tune to the output frequency f_o of the ultrasonic electromechanical system 132002. The input frequency is generated by a crystal oscillator 132008 and is input into a fixed counter 132010 to scale the frequency to a suitable value. The outputs of the fixed counter 132010 and the programmable counter 132006 are applied to a phase/frequency detector 132012. The output of the phase/frequency detector 132012 is applied to an amplifier/active filter circuit 132014 to generate a tuning voltage V_t that is applied to a voltage controlled oscillator 132016 (VCO). The VCO 132016 applies the output frequency f_o to an ultrasonic transducer portion of the ultrasonic electromechanical system 132002, shown here modeled as an equivalent electrical circuit. The voltage and current signals applied to the ultrasonic transducer are monitored by a voltage sensor 132018 and a current sensor 132020.

[0641] The outputs of the voltage and current sensors 132018, 132020 are applied to another phase/frequency detector 132022 to determine the phase angle between the voltage and current as measured by the voltage and current sensors 132018, 132020. The output of the phase/frequency detector 132022 is applied to one channel of a high speed analog to digital converter 132024 (ADC) and is provided to the processor 132004 therethrough. Optionally, the outputs of the voltage and current sensors 132018, 132020 may be

applied to respective channels of the two-channel ADC **132024** and provided to the processor **132004** for zero crossing, FFT, or other algorithm described herein for determining the phase angle between the voltage and current signals applied to the ultrasonic electromechanical system **132002**.

[0642] Optionally the tuning voltage V_r , which is proportional to the output frequency f_o , may be fed back to the processor **132004** via the ADC **132024**. This provides the processor **132004** with a feedback signal proportional to the output frequency f_o and can use this feedback to adjust and control the output frequency f_o .

[0643] Estimating the State of the Jaw (Pad Burn Through, Staples, Broken Blade, Bone in Jaw, Tissue in Jaw)

[0644] A challenge with ultrasonic energy delivery is that ultrasonic acoustics applied on the wrong materials or the wrong tissue can result in device failure, for example, clamp arm pad burn through or ultrasonic blade breakage. It is also desirable to detect what is located in the jaws of an end effector of an ultrasonic device and the state of the jaws without adding additional sensors in the jaws. Locating sensors in the jaws of an ultrasonic end effector poses reliability, cost, and complexity challenges.

[0645] Ultrasonic spectroscopy smart blade algorithm techniques may be employed for estimating the state of the jaw (clamp arm pad burn through, staples, broken blade, bone in jaw, tissue in jaw, back-cutting with jaw closed, etc.) based on the impedance

$$Z_g(t) = \frac{V_g(t)}{I_g(t)}$$

of an ultrasonic transducer configured to drive an ultrasonic transducer blade, in accordance with at least one aspect of the present disclosure. The impedance $Z_g(t)$, magnitude $|Z|$, and phase φ are plotted as a function of frequency f .

[0646] Dynamic mechanical analysis (DMA), also known as dynamic mechanical spectroscopy or simply mechanical spectroscopy, is a technique used to study and characterize materials. A sinusoidal stress is applied to a material, and the strain in the material is measured, allowing the determination of the complex modulus of the material. The spectroscopy as applied to ultrasonic devices includes exciting the tip of the ultrasonic blade with a sweep of frequencies (compound signals or traditional frequency sweeps) and measuring the resulting complex impedance at each frequency. The complex impedance measurements of the ultrasonic transducer across a range of frequencies are used in a classifier or model to infer the characteristics of the ultrasonic end effector. In one aspect, the present disclosure provides a technique for determining the state of an ultrasonic end effector (clamp arm, jaw) to drive automation in the ultrasonic device (such as disabling power to protect the device, executing adaptive algorithms, retrieving information, identifying tissue, etc.).

[0647] FIG. **54** is a spectra **132030** of an ultrasonic device with a variety of different states and conditions of the end effector where the impedance $Z_g(t)$, magnitude $|Z|$, and phase φ are plotted as a function of frequency f , in accordance with at least one aspect of the present disclosure. The spectra **132030** is plotted in three-dimensional space where

frequency (Hz) is plotted along the x-axis, phase (Rad) is plotted along the y-axis, and magnitude (Ohms) is plotted along the z-axis.

[0648] Spectral analysis of different jaw bites and device states produces different complex impedance characteristic patterns (fingerprints) across a range of frequencies for different conditions and states. Each state or condition has a different characteristic pattern in 3D space when plotted. These characteristic patterns can be used to estimate the condition and state of the end effector. FIG. **54** shows the spectra for air **132032**, clamp arm pad **132034**, chamois **132036**, staple **132038**, and broken blade **132040**. The chamois **132036** may be used to characterize different types of tissue.

[0649] The spectra **132030** can be evaluated by applying a low-power electrical signal across the ultrasonic transducer to produce a non-therapeutic excitation of the ultrasonic blade. The low-power electrical signal can be applied in the form of a sweep or a compound Fourier series to measure the impedance

$$Z_g(t) = \frac{V_g(t)}{I_g(t)}$$

across the ultrasonic transducer at a range of frequencies in series (sweep) or in parallel (compound signal) using an FFT.

Methods of Classification of New Data

[0650] For each characteristic pattern, a parametric line can be fit to the data used for training using a polynomial, a Fourier series, or any other form of parametric equation as may be dictated by convenience. A new data point is then received and is classified by using the Euclidean perpendicular distance from the new data point to the trajectory that has been fitted to the characteristic pattern training data. The perpendicular distance of the new data point to each of the trajectories (each trajectory representing a different state or condition) is used to assign the point to a state or condition.

[0651] The probability distribution of distance of each point in the training data to the fitted curve can be used to estimate the probability of a correctly classified new data point. This essentially constructs a two-dimensional probability distribution in a plane perpendicular to the fitted trajectory at each new data point of the fitted trajectory. The new data point can then be included in the training set based on its probability of correct classification to make an adaptive, learning classifier that readily detects high-frequency changes in states but adapts to slow occurring deviations in system performance, such as a device getting dirty or the pad wearing out.

[0652] FIG. **55** is a graphical representation of a plot **132042** of a set of 3D training data set (S), where ultrasonic transducer impedance $Z_g(t)$, magnitude $|Z|$, and phase φ are plotted as a function of frequency f , in accordance with at least one aspect of the present disclosure. The 3D training data set (S) plot **132042** is graphically depicted in three-dimensional space where phase (Rad) is plotted along the x-axis, frequency (Hz) is plotted along the y-axis, magnitude (Ohms) is plotted along the z-axis, and a parametric Fourier series is fit to the 3D training data set (S). A methodology for

classifying data is based on the 3D training data set (S0 is used to generate the plot **132042**).

[0653] The parametric Fourier series fit to the 3D training data set (S) is given by:

$$\vec{p} = \vec{a}_0 + \sum_{n=1}^{\infty} \left(\vec{a}_n \cos \frac{n\pi t}{L} + \vec{b}_n \sin \frac{n\pi t}{L} \right)$$

[0654] For a new point \vec{z} , the perpendicular distance from \vec{p} to \vec{z} is found by:

$$D = \|\vec{p} - \vec{z}\|$$

[0655] When:

$$\frac{\partial D}{\partial T} = 0$$

[0656] Then:

$$D = D_{\perp}$$

[0657] A probability distribution of D can be used to estimate the probability of a data point \vec{z} belonging to the group S.

Control

[0658] Based on the classification of data measured before, during, or after activation of the ultrasonic transducer/ultrasonic blade, a variety of automated tasks and safety measures can be implemented. Similarly, the state of the tissue located in the end effector and temperature of the ultrasonic blade also can be inferred to some degree, and used to better inform the user of the state of the ultrasonic device or protect critical structures, etc. Temperature control of an ultrasonic blade is described in commonly owned U.S. Provisional Patent Application No. 62/640,417, filed Mar. 8, 2018, titled TEMPERATURE CONTROL IN ULTRASONIC DEVICE AND CONTROL SYSTEM THEREFOR, which is incorporated herein by reference in its entirety.

[0659] Similarly, power delivery can be reduced when there is a high probability that the ultrasonic blade is contacting the clamp arm pad (e.g., without tissue in between) or if there is a probability that the ultrasonic blade has broken or that the ultrasonic blade is touching metal (e.g., a staple). Furthermore, back-cutting can be disallowed if the jaw is closed and no tissue is detected between the ultrasonic blade and the clamp arm pad.

Integration of Other Data to Improve Classification

[0660] This system can be used in conjunction with other information provided by sensors, the user, metrics on the patient, environmental factors, etc., by combing the data from this process with the aforementioned data using probability functions and a Kalman filter. The Kalman filter determines the maximum likelihood of a state or condition occurring given a plethora of uncertain measurements of varying confidence. Since this method allows for an assignment of probability to a newly classified data point, this algorithm's information can be implemented with other measures or estimates in a Kalman filter.

[0661] FIG. **56** is a logic flow diagram **132044** depicting a control program or a logic configuration to determine jaw conditions based on the complex impedance characteristic pattern (fingerprint), in accordance with at least one aspect of the present disclosure. Prior to determining jaw conditions based on the complex impedance characteristic pattern (fingerprint), a database is populated with reference complex impedance characteristic patterns or a training data sets (S) that characterize various jaw conditions, including, without limitation, air **132032**, clamp arm pad **132034**, chamois **132036**, staple **132038**, broken blade **132040**, as shown in FIG. **82**, and a variety of tissue types and conditions. The chamois dry or wet, full byte or tip, may be used to characterize different types of tissue. The data points used to generate reference complex impedance characteristic patterns or a training data set (S) are obtained by applying a sub-therapeutic drive signal to the ultrasonic transducer, sweeping the driving frequency over a predetermined range of frequencies from below resonance to above resonance, measuring the complex impedance at each of the frequencies, and recording the data points. The data points are then fit to a curve using a variety of numerical methods including polynomial curve fit, Fourier series, and/or parametric equation. A parametric Fourier series fit to the reference complex impedance characteristic patterns or a training data set (S) is described herein.

[0662] Once the reference complex impedance characteristic patterns or a training data sets (S) are generated, the ultrasonic instrument measures new data points, classifies the new points, and determines whether the new data points should be added to the reference complex impedance characteristic patterns or a training data sets (S).

[0663] Turning now to the logic flow diagram of FIG. **56**, in one aspect, the processor or control circuit measures **132046** a complex impedance of an ultrasonic transducer, wherein the complex impedance is defined as

$$Z_g(t) = \frac{V_g(t)}{I_g(t)}$$

The processor or control circuit receives **132048** a complex impedance measurement data point and compares **132050** the complex impedance measurement data point to a data point in a reference complex impedance characteristic pattern. The processor or control circuit classifies **132052** the complex impedance measurement data point based on a result of the comparison analysis and assigns **132054** a state or condition of the end effector based on the result of the comparison analysis.

[0664] In one aspect, the processor or control circuit receives the reference complex impedance characteristic pattern from a database or memory coupled to the processor. In one aspect, the processor or control circuit generates the reference complex impedance characteristic pattern as follows. A drive circuit coupled to the processor or control circuit applies a nontherapeutic drive signal to the ultrasonic transducer starting at an initial frequency, ending at a final frequency, and at a plurality of frequencies therebetween. The processor or control circuit measures the impedance of the ultrasonic transducer at each frequency and stores a data point corresponding to each impedance measurement. The processor or control circuit curve fits a plurality of data points to generate a three-dimensional curve of representa-

tive of the reference complex impedance characteristic pattern, wherein the magnitude $|Z|$ and phase φ are plotted as a function of frequency f . The curve fitting includes a polynomial curve fit, a Fourier series, and/or a parametric equation.

[0665] In one aspect, the processor or control circuit receives a new impedance measurement data point and classifies the new impedance measurement data point using a Euclidean perpendicular distance from the new impedance measurement data point to a trajectory that has been fitted to the reference complex impedance characteristic pattern. The processor or control circuit estimates a probability that the new impedance measurement data point is correctly classified. The processor or control circuit adds the new impedance measurement data point to the reference complex impedance characteristic pattern based on the probability of the estimated correct classification of the new impedance measurement data point. In one aspect, the processor or control circuit classifies data based on a training data set (S), where the training data set (S) comprises a plurality of complex impedance measurement data, and curve fits the training data set (S) using a parametric Fourier series, wherein S is defined herein and wherein the probability distribution is used to estimate the probability of the new impedance measurement data point belonging to the group S.

State of Jaw Classifier Based on Model

[0666] There has been an existing interest in classifying matter located within the jaws of an ultrasonic device including tissue types and condition. In various aspects, it can be shown that with high data sampling and sophisticated pattern recognition this classification is possible. The approach is based on impedance as a function of frequency, where magnitude, phase, and frequency are plotted in 3D the patterns look like ribbons as shown in FIGS. 54 and 55 and the logic flow diagram of FIG. 56. This disclosure provides an alternative smart blade algorithm approach that is based on a well-established model for piezoelectric transducers.

[0667] By way of example, the equivalent electrical lumped parameter model is known to be an accurate model of the physical piezoelectric transducer. It is based on the Mittag-Leffler expansion of a tangent near a mechanical resonance. When the complex impedance or the complex admittance is plotted as an imaginary component versus a real component, circles are formed. FIG. 57 is a circle plot 132056 of complex impedance plotted as an imaginary component versus real components of a piezoelectric vibrator, in accordance with at least one aspect of the present disclosure. FIG. 58 is a circle plot 132058 of complex admittance plotted as an imaginary component versus real components of a piezoelectric vibrator, in accordance with at least one aspect of the present disclosure. The circles depicted in FIGS. 57 and 58 are taken from the IEEE 177 Standard, which is incorporated herein by reference in its entirety. Tables 1-4 are taken from the IEEE 177 Standard and disclosed herein for completeness.

[0668] The circle is created as the frequency is swept from below resonance to above resonance. Rather than stretching the circle out in 3D, a circle is identified and the radius (r) and offsets (a, b) of the circle are estimated. These values are then compared with established values for given conditions. These conditions may be: 1) open nothing in jaws, 2) tip bite 3) full bite and staple in jaws. If the sweep generates

multiple resonances, circles of different characteristics will be present for each resonance. Each circle will be drawn out before the next if the resonances are separated. Rather than fitting a 3D curve with a series approximation, the data is fitted with a circle. The radius (r) and offsets (a, b) can be calculated using a processor programmed to execute a variety of mathematical or numerical techniques described below. These values may be estimated by capturing an image of a circle and, using image processing techniques, the radius (r) and offsets (a, b) that define the circle are estimated.

[0669] FIG. 59 is a circle plot 132060 of complex admittance for a 55.5 kHz ultrasonic piezoelectric transducer for lumped parameters inputs and outputs specified hereinbelow. Values for a lumped parameter model were used to generate the complex admittance. A moderate load was applied in the model. The obtained admittance circle generated in MathCad is shown in FIG. 59. The circle plot 132060 is formed when the frequency is swept from 54 to 58 kHz.

[0670] The lumped parameter input values are:

$$[0671] \quad C_0 = 3.0 \text{ nF}$$

$$[0672] \quad C_s = 8.22 \text{ pF}$$

$$[0673] \quad L_s = 1.0 \text{ H}$$

$$[0674] \quad R_s = 450 \Omega$$

[0675] The outputs of the model based on the inputs are:

$$am = \frac{D \cdot C - B \cdot C}{A \cdot C - B^2} = 1.013 \cdot 10^3$$

$$bm = \frac{A \cdot E - B \cdot D}{A \cdot C - B^2} = -954.585$$

$$rm = \frac{1}{fpts} \left(\sum_i^{fps} \sqrt{((Zout_{1,i} - am)^2 + (Zout_{2,i} - bm)^2)} \right) = 1.012 \cdot 10^3$$

[0676] The output values are used to plot the circle plot 132060 shown in FIG. 59. The circle plot 132060 has a radius (r) and the center 132062 is offset (a, b) from the origin 132064 as follows:

$$r = 1.012 \cdot 10^3$$

$$a = 1.013 \cdot 10^3$$

$$b = -954.585$$

[0677] The summations A-E specified below are needed to estimate the circle plot 132060 plot for the example given in FIG. 59, in accordance with at least one aspect of the present disclosure. Several algorithms exist to calculate a fit to a circle. A circle is defined by its radius (r) and offsets (a, b) of the center from the origin:

$$r^2 = (x-a)^2 + (y-b)^2$$

[0678] The modified least squares method (Umbach and Jones) is convenient in that there a simple close formed solution for a, b, and r.

$$\hat{a} = \frac{DC - BE}{AC - B^2}$$

$$\hat{b} = \frac{AE - BD}{AC - B^2}$$

-continued

$$\hat{r} = \frac{1}{n} \sum_{i=1}^n \sqrt{(x_i - \hat{a})^2 + (y_i - \hat{b})^2}$$

[0679] The caret symbol over the variable “a” indicates an estimate of the true value. A, B, C, D, and E are summations of various products which are calculated from the data. They are included herein for completeness as follows:

$$A := fpts \cdot \sum_i^{fpts} (Zout_{1,i})^2 - \left(\sum_i^{fpts} (Zout_{1,i}) \right)^2 = 5.463 \cdot 10^{10}$$

$$B := fpts \sum_i^{fpts} (Zout_{1,i} \cdot Zout_{2,i}) - \left(\sum_i^{fpts} (Zout_{1,i}) \right) \cdot \left(\sum_i^{fpts} (Zout_{2,i}) \right) = 5.461 \cdot 10^7$$

$$C := fpts \sum_i^{fpts} (Zout_{2,i})^2 - \left(\sum_i^{fpts} (Zout_{2,i}) \right)^2 = 5.445 \cdot 10^{10}$$

$$D := 0.5 \cdot \left(fpts \sum_i^{fpts} (Zout_{1,i} \cdot (Zout_{2,i})^2) - \left(\sum_i^{fpts} (Zout_{1,i}) \right) \cdot \left(\sum_i^{fpts} (Zout_{2,i})^2 \right) + fpts \sum_i^{fpts} (Zout_{1,i}^3) - \left(\sum_i^{fpts} (Zout_{1,i}) \right) \cdot \left(\sum_i^{fpts} (Zout_{1,i})^2 \right) \right) = 5.529 \cdot 10^3$$

$$E := 0.5 \cdot \left(fpts \sum_i^{fpts} (Zout_{2,i} \cdot (Zout_{1,i})^2) - \left(\sum_i^{fpts} (Zout_{2,i}) \right) \cdot \left(\sum_i^{fpts} (Zout_{1,i})^2 \right) + fpts \sum_i^{fpts} (Zout_{2,i}^3) - \left(\sum_i^{fpts} (Zout_{2,i}) \right) \cdot \left(\sum_i^{fpts} (Zout_{2,i})^2 \right) \right) = -5.192 \cdot 10^{13}$$

[0680] Z1,i is a first vector of the real components referred to as conductance;

[0681] Z2,i is a second of the imaginary components referred to as susceptance; and

[0682] Z3,i is a third vector that represents the frequencies at which admittances are calculated.

[0683] This disclosure will work for ultrasonic systems and may possibly be applied to electrosurgical systems, even though electrosurgical systems do not rely on a resonance.

[0684] FIGS. 60-64 illustrate images taken from an impedance analyzer showing impedance/admittance circle plots for an ultrasonic device with the end effector jaw in various open or closed configurations and loading. The circle plots in solid line depict impedance and the circle plots in broken lines depict admittance, in accordance with at least one aspect of the present disclosure. By way of example, the impedance/admittance circle plots are generated by connecting an ultrasonic device to an impedance analyzer. The display of the impedance analyzer is set to complex impedance and complex admittance, which can be selectable from the front panel of the impedance analyzer. An initial display may be obtained with the jaw of the ultrasonic end effector

in an open position and the ultrasonic device in an unloaded state, as described below in connection with FIG. 60, for example. The autoscale display function of the impedance analyzer may be used to generate both the complex impedance and admittance circle plots. The same display is used for subsequent runs of the ultrasonic device with different loading conditions as shown in the subsequent FIGS. 60-64. A LabVIEW application may be employed to upload the data files. In another technique, the display images may be captured with a camera, such as a smartphone camera, like an iPhone or Android. As such, the image of the display may include some “keystone-ing” and in general may not appear to be parallel to the screen. Using this technique, the circle plot traces on the display will appear distorted in the captured image. With this approach, the material located in the jaws of the ultrasonic end effector can be classified.

[0685] The complex impedance and complex admittance are just the reciprocal of one another. No new information should be added by looking at both. Another consideration includes determining how sensitive the estimates are to noise when using complex impedance or complex admittance.

[0686] In the examples illustrated in FIGS. 60-64, the impedance analyzer is set up with a range to just capture the main resonance. By scanning over a wider range of frequencies more resonances may be encountered and multiple circle plots may be formed. An equivalent circuit of an ultrasonic transducer may be modeled by a first “motional” branch having a serially connected inductance Ls, resistance Rs and capacitance Cs that define the electromechanical properties of the resonator, and a second capacitive branch having a static capacitance C0. In the impedance/admittance plots shown in FIGS. 60-64 that follow, the values of the components of the equivalent circuit are:

- [0687]** Ls=L1=1.1068 H
- [0688]** Rs=R1=311.352Ω
- [0689]** Cs=C1=7.43265 pF
- [0690]** C0=C0=3.64026 nF

[0691] The oscillator voltage applied to the ultrasonic transducer is 500 mV and the frequency is swept from 55 kHz to 56 kHz. The impedance (Z) scale is 200 Ω/div and the admittance (Y) scale is 500 μS/div. Measurements of values that may characterize the impedance (Z) and admittance (Y) circle plots may be obtained at the locations on the circle plots as indicated by an impedance cursor and an admittance cursor.

State of Jaw: Open with No Loading

[0692] FIG. 60 is a graphical display 132066 of an impedance analyzer showing complex impedance (Z)/admittance (Y) circle plots 132068, 132070 for an ultrasonic device with the jaw open and no loading where a circle plot 132068 in solid line depicts complex impedance and a circle plot 132070 in broken line depicts complex admittance, in accordance with at least one aspect of the present disclosure. The oscillator voltage applied to the ultrasonic transducer is 500 mV and the frequency is swept from 55 kHz to 56 kHz. The impedance (Z) scale is 200 Ω/div and the admittance (Y) scale is 500 μS/div. Measurements of values that may characterize the complex impedance (Z) and admittance (Y) circle plots 132068, 132070 may be obtained at locations on the circle plots 132068, 132070 as indicated by the impedance cursor 132072 and the admittance cursor 132074. Thus, the impedance cursor 132072 is located at a portion of the

impedance circle plot **132068** that is equivalent to about 55.55 kHz, and the admittance cursor **132074** is located at a portion of the admittance circle plot **132070** that is equivalent to about 55.29 kHz. As depicted in FIG. 60, the position of the impedance cursor **132072** corresponds to values of:

$$[0693] \quad R=1.66026\Omega$$

$$[0694] \quad X=-697.309\Omega$$

[0695] where R is the resistance (real value) and X is the reactance (imaginary value). Similarly, the position of the admittance cursor **132074** corresponds to values of:

$$[0696] \quad G=64.0322 \mu\text{S}$$

$$[0697] \quad B=1.63007 \text{ mS}$$

[0698] where G is the conductance (real value) and B is susceptance (imaginary value).

State of Jaw: Clamped on Dry Chamois

[0699] FIG. 61 is a graphical display **132076** of an impedance analyzer showing complex impedance (Z)/admittance (Y) circle plots **132078**, **132080** for an ultrasonic device with the jaw of the end effector clamped on dry chamois where the impedance circle plot **132078** is shown in solid line and the admittance circle plot **132080** is shown in broken line, in accordance with at least one aspect of the present disclosure. The voltage applied to the ultrasonic transducer is 500 mV and the frequency is swept from 55 kHz to 56 kHz. The impedance (Z) scale is 200 Ω /div and the admittance (Y) scale is 500 μS /div.

[0700] Measurements of values that may characterize the complex impedance (Z) and admittance (Y) circle plots **132078**, **132080** may be obtained at locations on the circle plots **132078**, **132080** as indicated by the impedance cursor **132082** and the admittance cursor **132084**. Thus, the impedance cursor **132082** is located at a portion of the impedance circle plot **132078** that is equivalent to about 55.68 kHz, and the admittance cursor **132084** is located at a portion of the admittance circle plot **132080** that is equivalent to about 55.29 kHz. As depicted in FIG. 61, the position of the impedance cursor **132082** corresponds to values of:

$$[0701] \quad R=434.577\Omega$$

$$[0702] \quad X=-758.772\Omega$$

[0703] where R is the resistance (real value) and X is the reactance (imaginary value). Similarly, the position of the admittance cursor **132084** corresponds to values of:

$$[0704] \quad G=85.1712 \mu\text{S}$$

$$[0705] \quad B=1.49569 \text{ mS}$$

[0706] where G is the conductance (real value) and B is susceptance (imaginary value).

State of Jaw: Tip Clamped on Moist Chamois

[0707] FIG. 62 is a graphical display **132086** of an impedance analyzer showing complex impedance (Z)/admittance (Y) circle plots **132098**, **132090** for an ultrasonic device with the jaw tip clamped on moist chamois where the impedance circle plot **132088** is shown in solid line and the admittance circle plot **132090** is shown in broken line, in accordance with at least one aspect of the present disclosure. The voltage applied to the ultrasonic transducer is 500 mV and the frequency is swept from 55 kHz to 56 kHz. The impedance (Z) scale is 200 Ω /div and the admittance (Y) scale is 500 μS /div.

[0708] Measurements of values that may characterize the complex impedance (Z) and complex admittance (Y) circle plots **132088**, **132090** may be obtained at locations on the

circle plots **132088**, **132090** as indicated by the impedance cursor **132092** and the admittance cursor **132094**. Thus, the impedance cursor **132092** is located at a portion of the impedance circle plot **132088** that is equivalent to about 55.68 kHz, and the admittance cursor **132094** is located at a portion of the admittance circle plot **132090** that is equivalent to about 55.29 kHz. As depicted in FIG. 63, the impedance cursor **132092** corresponds to values of:

$$[0709] \quad R=445.259\Omega$$

$$[0710] \quad X=-750.082\Omega$$

[0711] where R is the resistance (real value) and X is the reactance (imaginary value). Similarly, the admittance cursor **132094** corresponds to values of:

$$[0712] \quad G=96.2179 \mu\text{S}$$

$$[0713] \quad B=1.50236 \text{ mS}$$

[0714] where G is the conductance (real value) and B is susceptance (imaginary value).

State of Jaw: Fully Clamped on Moist Chamois

[0715] FIG. 63 is a graphical display **132096** of an impedance analyzer showing complex impedance (Z)/admittance (Y) circle plots **132098**, **132100** for an ultrasonic device with the jaw fully clamped on moist chamois where the impedance circle plot **132098** is shown in solid line and the admittance circle plot **132100** is shown in broken line, in accordance with at least one aspect of the present disclosure. The voltage applied to the ultrasonic transducer is 500 mV and the frequency is swept from 55 kHz to 56 kHz. The impedance (Z) scale is 200 Ω /div and the admittance (Y) scale is 500 μS /div.

[0716] Measurements of values that may characterize the impedance and admittance circle plots **132098**, **132100** may be obtained at locations on the circle plots **132098**, **132100** as indicated by the impedance cursor **132102** and admittance cursor **132104**. Thus, the impedance cursor **132102** is located at a portion of the impedance circle plot **132098** equivalent to about 55.63 kHz, and the admittance cursor **132104** is located at a portion of the admittance circle plot **132100** equivalent to about 55.29 kHz. As depicted in FIG. 63, the impedance cursor **132102** corresponds to values of R, the resistance (real value, not shown), and X, the reactance (imaginary value, also not shown).

[0717] Similarly, the admittance cursor **132104** corresponds to values of:

$$[0718] \quad G=137.272 \mu\text{S}$$

$$[0719] \quad B=1.48481 \text{ mS}$$

[0720] where G is the conductance (real value) and B is susceptance (imaginary value).

State of Jaw: Open with No Loading

[0721] FIG. 64 is a graphical display **132106** of an impedance analyzer showing impedance(Z)/admittance (Y) circle plots where frequency is swept from 48 kHz to 62 kHz to capture multiple resonances of an ultrasonic device with the jaw open and no loading where the area designated by the rectangle **132108** shown in broken line is to help see the impedance circle plots **132110a**, **132110b**, **132110c** shown in solid line and the admittance circle plots **132112a**, **132112b**, **132112c**, in accordance with at least one aspect of the present disclosure. The voltage applied to the ultrasonic transducer is 500 mV and the frequency is swept from 48 kHz to 62 kHz. The impedance (Z) scale is 500 Ω /div and the admittance (Y) scale is 500 μS /div.

[0722] Measurements of values that may characterize the impedance and admittance circle plots 132110a-c, 132112a-c may be obtained at locations on the impedance and admittance circle plots 132110a-c, 132112a-c as indicated by the impedance cursor 132114 and the admittance cursor 132116. Thus, the impedance cursor 132114 is located at a portion of the impedance circle plots 132110a-c equivalent to about 55.52 kHz, and the admittance cursor 132116 is located at a portion of the admittance circle plot 132112a-c equivalent to about 59.55 kHz. As depicted in FIG. 64, the impedance cursor 132114 corresponds to values of:

[0723] R=1.86163 kΩ

[0724] X=-536.229Ω

[0725] where R is the resistance (real value) and X is the reactance (imaginary value). Similarly, the admittance cursor 132116 corresponds to values of:

[0726] G=649.956 μS

[0727] B=2.51975 mS where G is the conductance (real value) and B is susceptance (imaginary value).

[0728] Because there are only 400 samples across the sweep range of the impedance analyzer, there are only a few points about a resonance. So, the circle on the right side becomes choppy. But this is only due to the impedance analyzer and the settings used to cover multiple resonances.

[0729] When multiple resonances are present, there is more information to improve the classifier. The circle plots 132110a-c, 132112a-c fit can be calculated for each as encountered to keep the algorithm running fast. So once there is a cross of the complex admittance, which implies a circle, during the sweep, a fit can be calculated.

[0730] Benefits include in-the-jaw classifier based on data and a well-known model for ultrasonic systems. Count and characterizations of circles are well known in vision systems. So data processing is readily available. For example, a closed form solution exists to calculate the radius and axes' offsets for a circle. This technique can be relatively fast.

[0731] TABLE 2 is a list of symbols used for lumped parameter model of a piezoelectric transducer (from IEEE 177 Standard).

TABLE 2

Symbols	Meaning	SI Units	References		
			Equations	Tables	FIG.
B _p	Equivalent parallel susceptance of vibrator	mho		2	
C _o	Shunt (parallel) capacitance in the equivalent electric circuit	farad	2, 3, 4, 8	5	1, 4
C ₁	Motional capacitance in the equivalent electric circuit	farad	2, 3, 4, 6, 8, 9	5	1, 4
f	Frequency	hertz			3
f _a	Antiresonance frequency, zero susceptance	hertz		2, 4	2, 3
f _m	Frequency of maximum admittance (minimum impedance)	hertz		2, 4	2, 3
f _n	Frequency of minimum admittance (maximum impedance)	hertz		2, 4	2, 3
f _p	Parallel resonance frequency	hertz	2, 3	2, 4	2
	(lossless) = $\frac{1}{2\pi\sqrt{L_1\frac{C_1C_o}{C_1+C_o}}}$				
f _r	Resonance frequency, zero substance	hertz		2, 4	2, 3
f _B	Motional (series) resonance frequency $\frac{1}{2}$	hertz	2, 3, 6, 7, 9, 11a, 11b, 11c, 12,	2, 4	2, 3, 6, 8
G _p	Equivalent parallel conductance of vibrator		1		
L ₁	Motional inductance in the equivalent electric circuit	henry	8, 9		1, 4, 5
M	Figure of merit of a vibrator = $\frac{Q}{r}$	dimensionless	10, 11a, 11b	3, 4, 5	
	$M = \frac{1}{\omega_s C_o R_1}$				
Q	Quality factor Q = $\frac{\omega_s L_1}{R_1} = \frac{1}{\omega_s C_1 R_1} = rM$	dimensionless	12	3	6, 8
r	Capacitance ratio r = $\frac{C_o}{C_1}$	dimensionless	2, 3, 10, 11	2, 3, 4, 5	8

TABLE 2-continued

Symbols	Meaning	SI Units	References		
			Equations	Tables	FIG.
R_a	Impedance at zero phase angle near antiresonance	ohm			2, 3
R_e	Equivalent series resistance of vibrator	ohm			1, 2
R_r	Impedance at f_r zero phase angle	ohm			2, 3
R_1	Motional resistance in the equivalent electric circuit	ohm	4, 8, 10, 11a, 11b, 11c, 12	2.5	1, 3, 4, 6, 7, 8
X_e	Equivalent series reactance of vibrator	ohm			1,2
X_o	Reactance of shunt (parallel) capacitance at series resonance = $\frac{1}{\omega_s C_o}$	ohm	1, 4, 5	5	3, 7
X_1	Reactance of motional (series) arm of vibrator $X_1 = \omega L_1 - \frac{1}{\omega C_1}$	ohm		2	2
Y	Admittance of vibrator $Y = G_p + j B_p = \frac{1}{Z}$	mho	1		
Y_m	Maximum admittance of vibrator	mho			3
Y_n	Minimum admittance of vibrator	mho			3
Z	Impedance of vibrator $Z = R_e + j X_e$	ohm	1		
Z_m	Minimum impedance of vibrator	ohm			3
Z_n	Maximum impedance of vibrator	ohm			3
	Absolute value of impedance of vibrator $Z = \sqrt{R_e^2 + X_e^2}$	ohm		2	2
	Absolute value of impedance at f_m (minimum impedance)	ohm			2
	Absolute value of impedance at f_n (maximum impedance)	ohm			2
δ	Normalized damping factor $\delta = \frac{\omega_s C_o R_1}{2}$	dimensionless	1	2	
Ω	Normalized frequency factor $\Omega = \frac{f^2 - f_s^2}{f_p^2 - f_s^2}$	dimensionless	1	2	
ω	Circular (angular) frequency $\omega = 2\pi f$	hertz		2	
ω_s	Circular frequency at motional resonance $\omega_s = 2\pi f_s$	hertz			

[0732] TABLE 3 is a list of symbols for the transmission network (from IEEE 177 Standard).

TABLE 3

Symbols	Meaning	SI Units	References		
			Equations	Tables	FIG.
b	Normalized compensation factor $1 - \frac{1}{4\pi^2 f_s^2 C_o L_o}$	dimensionless	4, 10	5	

TABLE 3-continued

Symbols	Meaning	SI Units	References		
			Equations	Tables	FIG.
B	Normalized admittance factor	dimensionless	10	5	
C	Normalized admittance factor	dimensionless	10	5	
C_{A-B}	Stray capacitance between the terminals A-B (FIG. 4)	farad			
C_L	Load capacitance	farad	6		4
C_T	Shunt capacitance terminating transmission circuit	farad	4, 10	5	4
C_{L1}	Load capacitance	farad	7		
C_{L2}	Load capacitance	farad	7		
e_2	Output voltage of transmission network	volt			4
f_{mT}	Frequency of maximum transmission	hertz	10		
F_{sL1}	Motional resonance frequency of combination of vibrator and C_{L1}	hertz	7		
F_{sL2}	Motional resonance frequency of combination of vibrator and C_{L2}	hertz	7		
i_1	Input current to transmission network	ampere			4
L_0	Compensation inductance shunting vibrator	henry			4
M_T	Figure of merit of transmission network termination = $\frac{1}{2\pi f_s C_T R_T} = \frac{X_T}{R_T}$	dimensionless	4, 10	5	
RT	Shunt resistance termination of transmission network	ohm	4, 11a, 11b, 11c, 12	5	4, 6, 7, 8
R_{sL2}	Standard resistor	ohm	4, 5	5	7
S	Detector sensitivity smallest detectable current change/ current	dimensionless	12		6
x	Normalized frequency factor = $\frac{f^2}{f_s^2} - 1 = \frac{\Omega}{r}$	dimensionless	12		
X_{A-B}	Reactance of stray capacitance C_{A-B}	ohm			
X_T	Reactance of C_T at the motional resonance frequency $X_T = \frac{1}{2\pi f_s C_T}$	ohm	4	5	
x_{mT}	Normalized frequency factor at the frequency of maximum transmission	dimensionless		5	
ΔC_L	$\Delta C_L = C_{L2} - C_{L1}$	farad	6, 7		
Δf	$\Delta f_1 = f_{sL1} - f_{sL2}$	hertz	6, 7		6, 8
Δf_1	$\Delta f_1 = f_{sL1} - f_s$	hertz	6, 7		
Δf_2	$\Delta f_1 = f_{sL2} - f_s$	hertz	6, 7		

*Refers to real roots; complex roots to be disregarded.

[0733] TABLE 4 is a list of solutions for various characteristic frequencies (from IEEE 177 Standard).

Solutions for the Various Characteristic Frequencies

[0734]

TABLE 4

Characteristic Frequencies	Meaning	Condition	Constituent Equation for Frequency	57 IEEE Root 14.S1 ¹
f_m	Frequency of maximum admittance (minimum impedance)	= 0	$-2\delta^2(\Omega + r) - 2\Omega r(1 - \Omega) - \Omega^2 = 0$	lower* f_m

TABLE 4-continued

Characteristic Frequencies	Meaning	Condition	Constituent Equation for Frequency	Root	57 IEEE 14.S1 ¹
f_a	Motional (series) resonance frequency	$X_1 = \circ$	$\Omega = 0$		f_a
f_r	Resonance frequency	$X_e = B_p = \circ$	$\Omega(1 - \Omega) - \delta^2 = 0$	lower	f_r
f_a	Antiresonance frequency	$X_e = B_p = \circ$	$\Omega(1 - \Omega) - \delta^2 = 0$	upper	f_a
f_p	Parallel resonance frequency (lossless)	$l = \infty R_1 = 0$	$\Omega = 1$		f_p
f_n	Frequency of minimum admittance (maximum impedance)	$= \circ$	$-2\delta^2(\Omega + r) - 2\Omega r(1 - \Omega) - \Omega^2 = 0$	upper*	f_n

*Refers to real roots; complex roots to be disregarded

[0735] TABLE 5 is a list of losses of three classes of piezoelectric materials.

TABLE 5

Type of Piezoelectric Vibrator	Q = Mr	r	Q'/r min
Piezoelectric Ceramics	90-500	2-40	200
Water-Soluble	200-50,000	3-500	80
Piezoelectric Crystals			
Quartz	10 ⁴ -10 ⁷	100-50,000	2000

Minimum Values for the Ratio Q'/r to be Expected for Various Types of Piezoelectric Vibrators

[0736] TABLE 6 illustrates jaw conditions, estimated parameters of a circle based on real time measurements of complex impedance/admittance, radius (re) and offsets (ae and be) of the circle represented by measured variables Re, Ge, Xe, Be, and parameters of a reference circle plots, as described in FIGS. 60-64, based on real time measurements of complex impedance/admittance, radius (rr) and offsets (ar, br) of the reference circle represented by reference variables Rref, Gref, Xref, Bref. These values are then compared with established values for given conditions. These conditions may be: 1) open with nothing in jaws, 2) tip bite 3) full bite and staple in jaws. The equivalent circuit of the ultrasonic transducer was modeled as follows and the frequency was swept from 55 kHz to 56 kHz:

- [0737] Ls=L1=1.1068 H
- [0738] Rs=R1=311.352 Ω
- [0739] Cs=C1=7.43265 pF and
- [0740] C0=C0=3.64026 nF.

TABLE 6

Reference Jaw Conditions	Reference Circle Plot			
	R _{ref} (Ω)	G _{ref} (μ S)	X _{ref} (Ω)	B _{ref} (mS)
Jaw open and no loading	1.66026	64.0322	-697.309	1.63007
Jaw clamped on dry chamois	434.577	85.1712	-758.772	1.49569
Jaw tip clamped on moist chamois	445.259	96.2179	-750.082	1.50236
Jaw fully clamped on moist chamois		137.272		1.48481

[0741] In use, the ultrasonic generator sweeps the frequency, records the measured variables, and determines estimates Re, Ge, Xe, Be. These estimates are then com-

pared to reference variables Rref, Gref, Xref, Bref stored in memory (e.g., stored in a look-up table) and determines the jaw conditions. The reference jaw conditions shown in TABLE 6 are examples only. Additional or fewer reference jaw conditions may be classified and stored in memory. These variables can be used to estimate the radius and offsets of the impedance/admittance circle.

[0742] FIG. 65 is a logic flow diagram 132120 of a process depicting a control program or a logic configuration to determine jaw conditions based on estimates of the radius (r) and offsets (a, b) of an impedance/admittance circle, in accordance with at least one aspect of the present disclosure. Initially a data base or lookup table is populated with reference values based on reference jaw conditions as described in connection with FIGS. 60-64 and TABLE 6. A reference jaw condition is set and the frequency is swept from a value below resonance to a value above resonance. The reference values Rref, Gref, Xref, Bref that define the corresponding impedance/admittance circle plot are stored in a database or lookup table. During use, under control of a control program or logic configuration a processor or control circuit of the generator or instrument causes the frequency to sweep 132122 from below resonance to above resonance. The processor or control circuit measures and records 132124 (e.g., stores in memory) the variables Re, Ge, Xe, Be that define the corresponding impedance/admittance circle plot and compares 132126 them to the reference values Rref, Gref, Xref, Bref stored in the database or lookup table. The processor or control circuit determines 132128, e.g., estimates, the end effector jaw conditions based on the results of the comparison.

Temperature Inference

[0743] FIGS. 66A-66B are graphical representations 133000, 133010 of complex impedance spectra of the same ultrasonic device with a cold (room temperature) and hot ultrasonic blade, in accordance with at least one aspect of the present disclosure. As used herein, a cold ultrasonic blade refers to an ultrasonic blade at room temperature and a hot ultrasonic blade refers to an ultrasonic blade after it is frictionally heated in use. FIG. 66A is a graphical representation 133000 of impedance phase angle φ as a function of resonant frequency f_o of the same ultrasonic device with a cold and hot ultrasonic blade and FIG. 66B is a graphical representation 133010 of impedance magnitude |Z| as a function of resonant frequency f_o of the same ultrasonic device with a cold and hot ultrasonic blade. The impedance

phase angle φ and impedance magnitude $|Z|$ are at a minimum at the resonant frequency f_o .

[0744] The ultrasonic transducer impedance $Z_g(t)$ can be measured as the ratio of the drive signal generator voltage $V_g(t)$ and current $I_g(t)$ drive signals:

$$Z_g(t) = \frac{V_g(t)}{I_g(t)}$$

[0745] As shown in FIG. 66A, when the ultrasonic blade is cold, e.g., at room temperature and not frictionally heated, the electromechanical resonant frequency f_o of the ultrasonic device is approximately 55,500 Hz and the excitation frequency of the ultrasonic transducer is set to 55,500 Hz. Thus, when the ultrasonic transducer is excited at the electromechanical resonant frequency f_o and the ultrasonic blade is cold the phase angle φ is at minimum or approximately 0 Rad as indicated by the cold blade plot 133002. As shown in FIG. 66B, when the ultrasonic blade is cold and the ultrasonic transducer is excited at the electromechanical resonant frequency f_o , the impedance magnitude $|Z|$ is 800 Ω , e.g., the impedance magnitude $|Z|$ is at a minimum impedance, and the drive signal amplitude is at a maximum due to the series resonance equivalent circuit of the ultrasonic electromechanical system as depicted in FIG. 25.

[0746] With reference now back to FIGS. 66A and 66B, when the ultrasonic transducer is driven by generator voltage $V_g(t)$ and generator current $I_g(t)$ signals at the electromechanical resonant frequency f_o of 55,500 Hz, the phase angle φ between the generator voltage $V_g(t)$ and generator current $I_g(t)$ signals is zero, the impedance magnitude $|Z|$ is at a minimum impedance, e.g., 800 Ω , and the signal amplitude is at a peak or maximum due to the series resonance equivalent circuit of the ultrasonic electromechanical system. As the temperature of the ultrasonic blade increases, due to frictional heat generated in use, the electromechanical resonant frequency f_o' of the ultrasonic device decreases. Since the ultrasonic transducer is still driven by generator voltage $V_g(t)$ and generator current $I_g(t)$ signals at the previous (cold blade) electromechanical resonant frequency f_o of 55,500 Hz, the ultrasonic device operates off-resonance f_o' causing a shift in the phase angle φ between the generator voltage $V_g(t)$ and generator current $I_g(t)$ signals. There is also an increase in impedance magnitude $|Z|$ and a drop in peak magnitude of the drive signal relative to the previous (cold blade) electromechanical resonant frequency of 55,500 Hz. Accordingly, the temperature of the ultrasonic blade may be inferred by measuring the phase angle φ between the generator voltage $V_g(t)$ and the generator current $I_g(t)$ signals as the electromechanical resonant frequency f_o changes due to the changes in temperature of the ultrasonic blade.

[0747] As previously described, an electromechanical ultrasonic system includes an ultrasonic transducer, a waveguide, and an ultrasonic blade. As previously discussed, the ultrasonic transducer may be modeled as an equivalent series resonant circuit (see FIG. 25) comprising first branch having a static capacitance and a second "motional" branch having a serially connected inductance, resistance and capacitance that define the electromechanical properties of a resonator. The electromechanical ultrasonic system has an initial electromechanical resonant frequency defined by the physical properties of the ultrasonic transducer, the waveguide, and the ultrasonic blade. The ultrasonic transducer is

excited by an alternating voltage $V_g(t)$ and current $I_g(t)$ signal at a frequency equal to the electromechanical resonant frequency, e.g., the resonant frequency of the electromechanical ultrasonic system. When the electromechanical ultrasonic system is excited at the resonant frequency, the phase angle φ between the voltage $V_g(t)$ and current $I_g(t)$ signals is zero.

[0748] Stated in another way, at resonance, the analogous inductive impedance of the electromechanical ultrasonic system is equal to the analogous capacitive impedance of the electromechanical ultrasonic system. As the ultrasonic blade heats up, for example due to frictional engagement with tissue, the compliance of the ultrasonic blade (modeled as an analogous capacitance) causes the resonant frequency of the electromechanical ultrasonic system to shift. In the present example, the resonant frequency of the electromechanical ultrasonic system decreases as the temperature of the ultrasonic blade increases. Thus, the analogous inductive impedance of the electromechanical ultrasonic system is no longer equal to the analogous capacitive impedance of the electromechanical ultrasonic system causing a mismatch between the drive frequency and the new resonant frequency of the electromechanical ultrasonic system. Thus, with a hot ultrasonic blade, the electromechanical ultrasonic system operates "off-resonance." The mismatch between the drive frequency and the resonant frequency is manifested as a phase angle φ between the voltage $V_g(t)$ and current $I_g(t)$ signals applied to the ultrasonic transducer.

[0749] As previously discussed, the generator electronics can easily monitor the phase angle φ between the voltage $V_g(t)$ and current $I_g(t)$ signals applied to the ultrasonic transducer. The phase angle φ may be determined through Fourier analysis, weighted least-squares estimation, Kalman filtering, space-vector-based techniques, zero-crossing method, Lissajous figures, three-voltmeter method, crossed-coil method, vector voltmeter and vector impedance methods, phase standard instruments, phase-locked loops, among other techniques previously described. The generator can continuously monitor the phase angle φ and adjust the drive frequency until the phase angle φ goes to zero. At this point, the new drive frequency is equal to the new resonant frequency of the electromechanical ultrasonic system. The change in phase angle φ and/or generator drive frequency can be used as an indirect or inferred measurement of the temperature of the ultrasonic blade.

[0750] A variety of techniques are available to estimate temperature from the data in these spectra. Most notably, a time variant, non-linear set of state space equations can be employed to model the dynamic relationship between the temperature of the ultrasonic blade and the measured impedance

$$Z_g(t) = \frac{V_g(t)}{I_g(t)}$$

across a range of generator drive frequencies, where the range of generator drive frequencies is specific to device model.

Methods of Temperature Estimation

[0751] One aspect of estimating or inferring the temperature of an ultrasonic blade may include three steps. First,

define a state space model of temperature and frequency that is time and energy dependent. To model temperature as a function of frequency content, a set of non-linear state space equations are used to model the relationship between the electromechanical resonant frequency and the temperature of the ultrasonic blade. Second, apply a Kalman filter to improve the accuracy of the temperature estimator and state space model over time. Third, a state estimator is provided in the feedback loop of the Kalman filter to control the power applied to the ultrasonic transducer, and hence the ultrasonic blade, to regulate the temperature of the ultrasonic blade. The three steps are described hereinbelow.

Step 1

[0752] The first step is to define a state space model of temperature and frequency that is time and energy dependent. To model temperature as a function of frequency content, a set of non-linear state space equations are used to model the relationship between the electromechanical resonant frequency and the temperature of the ultrasonic blade. In one aspect, the state space model is given by:

$$\begin{bmatrix} \dot{F}_n \\ \dot{T} \end{bmatrix} = f(t, T(t), F_n(t), E(t))$$

$$\hat{y} = h(t, T(t), F_n(t), E(t))$$

[0753] The state space model represents the rate of change of the natural frequency of the electromechanical ultrasonic system \dot{F}_n and the rate of change of the temperature \dot{T} of the ultrasonic blade with respect to natural frequency $F_n(t)$, temperature $T(t)$, energy $E(t)$, and time t . \hat{y} represents the observability of variables that are measurable and observable such as the natural frequency $F_n(t)$ of the electromechanical ultrasonic system, the temperature $T(t)$ of the ultrasonic blade, the energy $E(t)$ applied to the ultrasonic blade, and time t . The temperature $T(t)$ of the ultrasonic blade is observable as an estimate.

Step 2

[0754] The second step is to apply a Kalman filter to improve temperature estimator and state space model. FIG. 67 is a diagram of a Kalman filter 133020 to improve the temperature estimator and state space model based on impedance according to the equation:

$$Z_g(t) = \frac{V_g(t)}{I_g(t)}$$

which represents the impedance across an ultrasonic transducer measured at a variety of frequencies, in accordance with at least one aspect of the present disclosure.

[0755] The Kalman filter 133020 may be employed to improve the performance of the temperature estimate and allows for the augmentation of external sensors, models, or prior information to improve temperature prediction in the midst of noisy data. The Kalman filter 133020 includes a regulator 133022 and a plant 133024. In control theory a plant 133024 is the combination of process and actuator. A plant 133024 may be referred to with a transfer function

which indicates the relation between an input signal and the output signal of a system. The regulator 133022 includes a state estimator 133026 and a controller K 133028. The state regulator 133026 includes a feedback loop 133030. The state regulator 133026 receives y , the output of the plant 133024, as an input and a feedback variable u . The state estimator 133026 is an internal feedback system that converges to the true value of the state of the system. The output of the state estimator 133026 is \hat{x} , the full feedback control variable including $F_n(t)$ of the electromechanical ultrasonic system, the estimate of the temperature $T(t)$ of the ultrasonic blade, the energy $E(t)$ applied to the ultrasonic blade, the phase angle φ , and time t . The input into the controller K 133028 is \hat{x} and the output of the controller K 133028 u is fed back to the state estimator 133026 and t of the plant 133024.

[0756] Kalman filtering, also known as linear quadratic estimation (LQE), is an algorithm that uses a series of measurements observed over time, containing statistical noise and other inaccuracies, and produces estimates of unknown variables that tend to be more accurate than those based on a single measurement alone, by estimating a joint probability distribution over the variables for each time-frame and thus calculating the maximum likelihood estimate of actual measurements. The algorithm works in a two-step process. In a prediction step, the Kalman filter 133020 produces estimates of the current state variables, along with their uncertainties. Once the outcome of the next measurement (necessarily corrupted with some amount of error, including random noise) is observed, these estimates are updated using a weighted average, with more weight being given to estimates with higher certainty. The algorithm is recursive and can run in real time, using only the present input measurements and the previously calculated state and its uncertainty matrix; no additional past information is required.

[0757] The Kalman filter 133020 uses a dynamics model of the electromechanical ultrasonic system, known control inputs to that system, and multiple sequential measurements (observations) of the natural frequency and phase angle of the applied signals (e.g., magnitude and phase of the electrical impedance of the ultrasonic transducer) to the ultrasonic transducer to form an estimate of the varying quantities of the electromechanical ultrasonic system (its state) to predict the temperature of the ultrasonic blade portion of the electromechanical ultrasonic system that is better than an estimate obtained using only one measurement alone. As such, the Kalman filter 133020 is an algorithm that includes sensor and data fusion to provide the maximum likelihood estimate of the temperature of the ultrasonic blade.

[0758] The Kalman filter 133020 deals effectively with uncertainty due to noisy measurements of the applied signals to the ultrasonic transducer to measure the natural frequency and phase shift data and also deals effectively with uncertainty due to random external factors. The Kalman filter 133020 produces an estimate of the state of the electromechanical ultrasonic system as an average of the predicted state of the system and of the new measurement using a weighted average. Weighted values provide better (i.e., smaller) estimated uncertainty and are more "trustworthy" than unweighted values. The weights may be calculated from the covariance, a measure of the estimated uncertainty of the prediction of the system's state. The result of the weighted average is a new state estimate that lies between the predicted and measured state, and has a better estimated uncer-

tainty than either alone. This process is repeated at every time step, with the new estimate and its covariance informing the prediction used in the following iteration. This recursive nature of the Kalman filter **133020** requires only the last “best guess,” rather than the entire history, of the state of the electromechanical ultrasonic system to calculate a new state.

[0759] The relative certainty of the measurements and current state estimate is an important consideration, and it is common to discuss the response of the filter in terms of the gain K of the Kalman filter **133020**. The Kalman gain K is the relative weight given to the measurements and current state estimate, and can be “tuned” to achieve particular performance. With a high gain K , the Kalman filter **133020** places more weight on the most recent measurements, and thus follows them more responsively. With a low gain K , the Kalman filter **133020** follows the model predictions more closely. At the extremes, a high gain close to one will result in a more jumpy estimated trajectory, while low gain close to zero will smooth out noise but decrease the responsiveness.

[0760] When performing the actual calculations for the Kalman filter **133020** (as discussed below), the state estimate and covariances are coded into matrices to handle the multiple dimensions involved in a single set of calculations. This allows for a representation of linear relationships between different state variables (such as position, velocity, and acceleration) in any of the transition models or covariances. Using a Kalman filter **133020** does not assume that the errors are Gaussian. However, the Kalman filter **133020** yields the exact conditional probability estimate in the special case that all errors are Gaussian-distributed.

Step 3

[0761] The third step uses a state estimator **133026** in the feedback loop **133032** of the Kalman filter **133020** for control of power applied to the ultrasonic transducer, and hence the ultrasonic blade, to regulate the temperature of the ultrasonic blade.

[0762] FIG. 68 is a graphical depiction **133040** of three probability distributions employed by the state estimator **133026** of the Kalman filter **133020** shown in FIG. 67 to maximize estimates, in accordance with at least one aspect of the present disclosure. The probability distributions include the prior probability distribution **133042**, the prediction (state) probability distribution **133044**, and the observation probability distribution **133046**. The three probability distributions **133042**, **133044**, **133046** are used in feedback control of power applied to an ultrasonic transducer to regulate temperature based on impedance across the ultrasonic transducer measured at a variety of frequencies, in accordance with at least one aspect of the present disclosure. The estimator used in feedback control of power applied to an ultrasonic transducer to regulate temperature based on impedance is given by the expression:

$$Z_g(t) = \frac{V_g(t)}{I_g(t)}$$

which is the impedance across the ultrasonic transducer measured at a variety of frequencies, in accordance with at least one aspect of the present disclosure.

[0763] The prior probability distribution **133042** includes a state variance defined by the expression:

$$(\sigma_k^{-1})^2 = \sigma_{k-1}^2 + \sigma_{P_k}^2$$

[0764] The state variance (σ_k^{-1}) is used to predict the next state of the system, which is represented as the prediction (state) probability distribution **133044**. The observation probability distribution **133046** is the probability distribution of the actual observation of the state of the system where the observation variance σ_m is used to define the gain, which is given by the following expression:

$$K = \frac{(\sigma_k^{-1})^2}{(\sigma_k^{-1})^2 + \sigma_m^2}$$

Feedback Control

[0765] Power input is decreased to ensure that the temperature (as estimated by the state estimator and of the Kalman filter) is controlled.

[0766] In one aspect, the initial proof of concept assumed a static, linear relationship between the natural frequency of the electromechanical ultrasonic system and the temperature of the ultrasonic blade. By reducing the power as a function of the natural frequency of the electromechanical ultrasonic system (i.e., regulating temperature with feedback control), the temperature of the ultrasonic blade tip could be controlled directly. In this example, the temperature of the distal tip of the ultrasonic blade can be controlled to not exceed the melting point of the Teflon pad.

[0767] FIG. 69A is a graphical representation **133050** of temperature versus time of an ultrasonic device without temperature feedback control. Temperature ($^{\circ}$ C.) of the ultrasonic blade is shown along the vertical axis and time (sec) is shown along the horizontal axis. The test was conducted with a chamois located in the jaws of the ultrasonic device. One jaw is the ultrasonic blade and the other jaw is the clamp arm with a TEFLON pad. The ultrasonic blade was excited at the resonant frequency while in frictional engagement with the chamois clamped between the ultrasonic blade and the clamp arm. Over time, the temperature ($^{\circ}$ C.) of the ultrasonic blade increases due to the frictional engagement with the chamois. Over time, the temperature profile **133052** of the ultrasonic blade increases until the chamois sample is cut after about 19.5 seconds at a temperature of 220° C. as indicated at point **133054**. Without temperature feedback control, after cutting the chamois sample, the temperature of the ultrasonic blade increases to a temperature well above the melting point of TEFLON $\sim 380^{\circ}$ C. up to $\sim 490^{\circ}$ C. At point **133056** the temperature of the ultrasonic blade reaches a maximum temperature of 490° C. until the TEFLON pad is completely melted. The temperature of the ultrasonic blade drops slightly from the peak temperature at point **133056** after the pad is completely gone.

[0768] FIG. 69B is a plot of temperature versus time of an ultrasonic device with temperature feedback control, in accordance with at least one aspect of the present disclosure. Temperature ($^{\circ}$ C.) of the ultrasonic blade is shown along the vertical axis and the time (sec) is shown along the horizontal axis. The test was conducted with a chamois sample located in the jaws of the ultrasonic device. One jaw is the ultrasonic

blade and the other jaw is the clamp arm with a TEFLON pad. The ultrasonic blade was excited at the resonant frequency while in frictional engagement with the chamois clamped between the ultrasonic blade and the clamp arm pad. Over time, the temperature profile **133062** of the ultrasonic blade increases until the chamois sample is cut after about 23 seconds at a temperature of 220° C. as indicated at point **133064**. With temperature feedback control, the temperature of the ultrasonic blade increases up to a maximum temperature of about 380° C., just below the melting point of TEFLON, as indicated at point **133066** and then is lowered to an average of about 330° C. as indicated generally at region **133068**, thus preventing the TEFLON pad from melting.

Application of Smart Ultrasonic Blade Technology

[0769] When an ultrasonic blade is immersed in a fluid-filled surgical field, the ultrasonic blade cools down during activation rendering less effective for sealing and cutting tissue in contact therewith. The cooling down of the ultrasonic blade may lead to longer activation times and/or hemostasis issues because adequate heat is not delivered to the tissue. In order to overcome the cooling of the ultrasonic blade, more energy delivery may be required to shorten the transection times and achieve suitable hemostasis under these fluid immersion conditions. Using a frequency-temperature feedback control system, if the ultrasonic blade temperature is detected to, either start out below, or remain below a certain temperature for a certain period of time, the output power of the generator can be increased to compensate for cooling due to blood/saline/other fluid present in the surgical field.

[0770] Accordingly, the frequency-temperature feedback control system described herein can improve the performance of an ultrasonic device especially when the ultrasonic blade is located or immersed, partially or wholly, in a fluid-filled surgical field. The frequency-temperature feedback control system described herein minimizes long activation times and/or potential issues with ultrasonic device performance in fluid-filled surgical field.

[0771] As previously described, the temperature of the ultrasonic blade may be inferred by detecting the impedance of the ultrasonic transducer given by the following expression:

$$Z_g(t) = \frac{V_g(t)}{I_g(t)}$$

or equivalently, detecting the phase angle φ between the voltage $V_g(t)$ and current $I_g(t)$ signals applied to the ultrasonic transducer. The phase angle φ information also may be used to infer the conditions of the ultrasonic blade. As discussed with particularity herein, the phase angle φ changes as a function of the temperature of the ultrasonic blade. Therefore, the phase angle φ information may be employed to control the temperature of the ultrasonic blade. This may be done, for example, by reducing the power delivered to the ultrasonic blade when the ultrasonic blade runs too hot and increasing the power delivered to the ultrasonic blade when the ultrasonic blade runs too cold. FIGS. 70A-70B are graphical representations of temperature feedback control for adjusting ultrasonic power applied to an

ultrasonic transducer when a sudden drop in temperature of an ultrasonic blade is detected.

[0772] FIG. 70A is a graphical representation of ultrasonic power output **133070** as a function of time, in accordance with at least one aspect of the present disclosure. Power output of the ultrasonic generator is shown along the vertical axis and time (sec) is shown along the horizontal axis. FIG. 70B is a graphical representation of ultrasonic blade temperature **133080** as a function of time, in accordance with at least one aspect of the present disclosure. Ultrasonic blade temperature is shown along the vertical axis and time (sec) is shown along the horizontal axis. The temperature of the ultrasonic blade increases with the application of constant power **133072** as shown in FIG. 70A. During use, the temperature of the ultrasonic blade suddenly drops. This may result from a variety of conditions, however, during use, it may be inferred that the temperature of the ultrasonic blade drops when it is immersed in a fluid-filled surgical field (e.g., blood, saline, water, etc.). At time t_0 , the temperature of the ultrasonic blade drops below the desired minimum temperature **133082** and the frequency-temperature feedback control algorithm detects the drop in temperature and begins to increase or “ramp up” the power as shown by the power ramp **133074** delivered to the ultrasonic blade to start raising the temperature of the ultrasonic blade above the desired minimum temperature **133082**.

[0773] With reference to FIGS. 70A and 70B, the ultrasonic generator is outputs substantially constant power **133072** as long the temperature of the ultrasonic blade remains above the desired minimum temperature **133082**. At t_0 , processor or control circuit in the generator or instrument or both detects the drop in temperature of the ultrasonic blade below the desired minimum temperature **133072** and initiates a frequency-temperature feedback control algorithm to raise the temperature of the ultrasonic blade above the minimum desired temperature **133082**. Accordingly, the generator power begins to ramp **133074** at t_1 corresponding to the detection of a sudden drop in the temperature of the ultrasonic blade at t_0 . Under the frequency-temperature feedback control algorithm, the power continues to ramp **133074** until the temperature of the ultrasonic blade is above the desired minimum temperature **133082**.

[0774] FIG. 71 is a logic flow diagram **133090** of a process depicting a control program or a logic configuration to control the temperature of an ultrasonic blade, in accordance with at least one aspect of the present disclosure. According to the process, the processor or control circuit of the generator or instrument or both executes one aspect of a frequency-temperature feedback control algorithm discussed in connection with FIGS. 70A and 70B to apply **133092** a power level to the ultrasonic transducer to achieve a desired temperature at the ultrasonic blade. The generator monitors **133094** the phase angle φ between the voltage $V_g(t)$ and current $I_g(t)$ signals applied to drive the ultrasonic transducer. Based on the phase angle φ , the generator infers **133096** the temperature of the ultrasonic blade using the techniques described herein in connection with FIGS. 66A-68. The generator determines **133098** whether the temperature of the ultrasonic blade is below a desired minimum temperature by comparing the inferred temperature of the ultrasonic blade to a predetermined desired temperature. The generator then adjusts the power level applied to the ultrasonic transducer based on the comparison. For example, the process continues along NO branch when the temperature of

the ultrasonic blade is at or above the desired minimum temperature and continues along YES branch when the temperature of the ultrasonic blade is below the desired minimum temperature. When the temperature of the ultrasonic blade is below the desired minimum temperature, the generator increases 133100 the power level to the ultrasonic transducer, e.g., by increasing the voltage $V_g(t)$ and/or current $I_g(t)$ signals, to raise the temperature of the ultrasonic blade and continues increasing the power level applied to the ultrasonic transducer until the temperature of the ultrasonic blade increases above the minimum desired temperature.

Situational Awareness

[0775] Referring now to FIG. 72, a timeline 5200 depicting situational awareness of a hub, such as the surgical hub 106 or 206, for example, is depicted. The timeline 5200 is an illustrative surgical procedure and the contextual information that the surgical hub 106, 206 can derive from the data received from the data sources at each step in the surgical procedure. The timeline 5200 depicts the typical steps that would be taken by the nurses, surgeons, and other medical personnel during the course of a lung segmentectomy procedure, beginning with setting up the operating theater and ending with transferring the patient to a post-operative recovery room.

[0776] The situationally aware surgical hub 106, 206 receives data from the data sources throughout the course of the surgical procedure, including data generated each time medical personnel utilize a modular device that is paired with the surgical hub 106, 206. The surgical hub 106, 206 can receive this data from the paired modular devices and other data sources and continually derive inferences (i.e., contextual information) about the ongoing procedure as new data is received, such as which step of the procedure is being performed at any given time. The situational awareness system of the surgical hub 106, 206 is able to, for example, record data pertaining to the procedure for generating reports, verify the steps being taken by the medical personnel, provide data or prompts (e.g., via a display screen) that may be pertinent for the particular procedural step, adjust modular devices based on the context (e.g., activate monitors, adjust the field of view (FOV) of the medical imaging device, or change the energy level of an ultrasonic surgical instrument or RF electro-surgical instrument), and take any other such action described above.

[0777] As the first step 5202 in this illustrative procedure, the hospital staff members retrieve the patient's EMR from the hospital's EMR database. Based on select patient data in the EMR, the surgical hub 106, 206 determines that the procedure to be performed is a thoracic procedure.

[0778] Second step 5204, the staff members scan the incoming medical supplies for the procedure. The surgical hub 106, 206 cross-references the scanned supplies with a list of supplies that are utilized in various types of procedures and confirms that the mix of supplies corresponds to a thoracic procedure. Further, the surgical hub 106, 206 is also able to determine that the procedure is not a wedge procedure (because the incoming supplies either lack certain supplies that are necessary for a thoracic wedge procedure or do not otherwise correspond to a thoracic wedge procedure).

[0779] Third step 5206, the medical personnel scan the patient band via a scanner that is communicably connected to the surgical hub 106, 206. The surgical hub 106, 206 can then confirm the patient's identity based on the scanned data.

[0780] Fourth step 5208, the medical staff turns on the auxiliary equipment. The auxiliary equipment being utilized can vary according to the type of surgical procedure and the techniques to be used by the surgeon, but in this illustrative case they include a smoke evacuator, insufflator, and medical imaging device. When activated, the auxiliary equipment that are modular devices can automatically pair with the surgical hub 106, 206 that is located within a particular vicinity of the modular devices as part of their initialization process. The surgical hub 106, 206 can then derive contextual information about the surgical procedure by detecting the types of modular devices that pair with it during this pre-operative or initialization phase. In this particular example, the surgical hub 106, 206 determines that the surgical procedure is a VATS procedure based on this particular combination of paired modular devices. Based on the combination of the data from the patient's EMR, the list of medical supplies to be used in the procedure, and the type of modular devices that connect to the hub, the surgical hub 106, 206 can generally infer the specific procedure that the surgical team will be performing. Once the surgical hub 106, 206 knows what specific procedure is being performed, the surgical hub 106, 206 can then retrieve the steps of that procedure from a memory or from the cloud and then cross-reference the data it subsequently receives from the connected data sources (e.g., modular devices and patient monitoring devices) to infer what step of the surgical procedure the surgical team is performing.

[0781] Fifth step 5210, the staff members attach the EKG electrodes and other patient monitoring devices to the patient. The EKG electrodes and other patient monitoring devices are able to pair with the surgical hub 106, 206. As the surgical hub 106, 206 begins receiving data from the patient monitoring devices, the surgical hub 106, 206 thus confirms that the patient is in the operating theater.

[0782] Sixth step 5212, the medical personnel induce anesthesia in the patient. The surgical hub 106, 206 can infer that the patient is under anesthesia based on data from the modular devices and/or patient monitoring devices, including EKG data, blood pressure data, ventilator data, or combinations thereof, for example. Upon completion of the sixth step 5212, the pre-operative portion of the lung segmentectomy procedure is completed and the operative portion begins.

[0783] Seventh step 5214, the patient's lung that is being operated on is collapsed (while ventilation is switched to the contralateral lung). The surgical hub 106, 206 can infer from the ventilator data that the patient's lung has been collapsed, for example. The surgical hub 106, 206 can infer that the operative portion of the procedure has commenced as it can compare the detection of the patient's lung collapsing to the expected steps of the procedure (which can be accessed or retrieved previously) and thereby determine that collapsing the lung is the first operative step in this particular procedure.

[0784] Eighth step 5216, the medical imaging device (e.g., a scope) is inserted and video from the medical imaging device is initiated. The surgical hub 106, 206 receives the medical imaging device data (i.e., video or image data) through its connection to the medical imaging device. Upon receipt of the medical imaging device data, the surgical hub 106, 206 can determine that the laparoscopic portion of the surgical procedure has commenced. Further, the surgical hub 106, 206 can determine that the particular procedure being

performed is a segmentectomy, as opposed to a lobectomy (note that a wedge procedure has already been discounted by the surgical hub **106, 206** based on data received at the second step **5204** of the procedure). The data from the medical imaging device **124** (FIG. **2**) can be utilized to determine contextual information regarding the type of procedure being performed in a number of different ways, including by determining the angle at which the medical imaging device is oriented with respect to the visualization of the patient's anatomy, monitoring the number or medical imaging devices being utilized (i.e., that are activated and paired with the surgical hub **106, 206**), and monitoring the types of visualization devices utilized. For example, one technique for performing a VATS lobectomy places the camera in the lower anterior corner of the patient's chest cavity above the diaphragm, whereas one technique for performing a VATS segmentectomy places the camera in an anterior intercostal position relative to the segmental fissure. Using pattern recognition or machine learning techniques, for example, the situational awareness system can be trained to recognize the positioning of the medical imaging device according to the visualization of the patient's anatomy. As another example, one technique for performing a VATS lobectomy utilizes a single medical imaging device, whereas another technique for performing a VATS segmentectomy utilizes multiple cameras. As yet another example, one technique for performing a VATS segmentectomy utilizes an infrared light source (which can be communicably coupled to the surgical hub as part of the visualization system) to visualize the segmental fissure, which is not utilized in a VATS lobectomy. By tracking any or all of this data from the medical imaging device, the surgical hub **106, 206** can thereby determine the specific type of surgical procedure being performed and/or the technique being used for a particular type of surgical procedure.

[**0785**] Ninth step **5218**, the surgical team begins the dissection step of the procedure. The surgical hub **106, 206** can infer that the surgeon is in the process of dissecting to mobilize the patient's lung because it receives data from the RF or ultrasonic generator indicating that an energy instrument is being fired. The surgical hub **106, 206** can cross-reference the received data with the retrieved steps of the surgical procedure to determine that an energy instrument being fired at this point in the process (i.e., after the completion of the previously discussed steps of the procedure) corresponds to the dissection step. In certain instances, the energy instrument can be an energy tool mounted to a robotic arm of a robotic surgical system.

[**0786**] Tenth step **5220**, the surgical team proceeds to the ligation step of the procedure. The surgical hub **106, 206** can infer that the surgeon is ligating arteries and veins because it receives data from the surgical stapling and cutting instrument indicating that the instrument is being fired. Similarly to the prior step, the surgical hub **106, 206** can derive this inference by cross-referencing the receipt of data from the surgical stapling and cutting instrument with the retrieved steps in the process. In certain instances, the surgical instrument can be a surgical tool mounted to a robotic arm of a robotic surgical system.

[**0787**] Eleventh step **5222**, the segmentectomy portion of the procedure is performed. The surgical hub **106, 206** can infer that the surgeon is transecting the parenchyma based on data from the surgical stapling and cutting instrument, including data from its cartridge. The cartridge data can

correspond to the size or type of staple being fired by the instrument, for example. As different types of staples are utilized for different types of tissues, the cartridge data can thus indicate the type of tissue being stapled and/or transected. In this case, the type of staple being fired is utilized for parenchyma (or other similar tissue types), which allows the surgical hub **106, 206** to infer that the segmentectomy portion of the procedure is being performed. [**0788**] Twelfth step **5224**, the node dissection step is then performed. The surgical hub **106, 206** can infer that the surgical team is dissecting the node and performing a leak test based on data received from the generator indicating that an RF or ultrasonic instrument is being fired. For this particular procedure, an RF or ultrasonic instrument being utilized after parenchyma was transected corresponds to the node dissection step, which allows the surgical hub **106, 206** to make this inference. It should be noted that surgeons regularly switch back and forth between surgical stapling/cutting instruments and surgical energy (i.e., RF or ultrasonic) instruments depending upon the particular step in the procedure because different instruments are better adapted for particular tasks. Therefore, the particular sequence in which the stapling/cutting instruments and surgical energy instruments are used can indicate what step of the procedure the surgeon is performing. Moreover, in certain instances, robotic tools can be utilized for one or more steps in a surgical procedure and/or handheld surgical instruments can be utilized for one or more steps in the surgical procedure. The surgeon(s) can alternate between robotic tools and handheld surgical instruments and/or can use the devices concurrently, for example. Upon completion of the twelfth step **5224**, the incisions are closed up and the post-operative portion of the procedure begins.

[**0789**] Thirteenth step **5226**, the patient's anesthesia is reversed. The surgical hub **106, 206** can infer that the patient is emerging from the anesthesia based on the ventilator data (i.e., the patient's breathing rate begins increasing), for example.

[**0790**] Lastly, the fourteenth step **5228** is that the medical personnel remove the various patient monitoring devices from the patient. The surgical hub **106, 206** can thus infer that the patient is being transferred to a recovery room when the hub loses EKG, BP, and other data from the patient monitoring devices. As can be seen from the description of this illustrative procedure, the surgical hub **106, 206** can determine or infer when each step of a given surgical procedure is taking place according to data received from the various data sources that are communicably coupled to the surgical hub **106, 206**.

[**0791**] Situational awareness is further described in U.S. Provisional Patent Application Ser. No. 62/611,341, titled INTERACTIVE SURGICAL PLATFORM, filed Dec. 28, 2017, which is herein incorporated by reference in its entirety. In certain instances, operation of a robotic surgical system, including the various robotic surgical systems disclosed herein, for example, can be controlled by the hub **106, 206** based on its situational awareness and/or feedback from the components thereof and/or based on information from the cloud **102**.

Situational Awareness of Electrosurgical Systems

[**0792**] Electrosurgical instruments are utilized to treat various tissue types by application of energy to the tissue. As described in connection with FIGS. **22-24**, an electrosurgical

instrument (e.g. surgical instruments **1104**, **1106**, **1108**) may be connected to a generator **1100**, and include an end effector (e.g. end effectors **1122**, **1124**, **1125**) configured to grasp and transmit therapeutic energy to tissue.

[**0793**] In various aspects, the end effector can be used to seal, weld, or coagulate tissue such as, for example, a blood vessel by application of energy to the blood vessel while grasped by the end effector. Since blood vessels are generally surrounded by protective tissue, the tissue has to be separated to expose the blood vessels for an effective seal to be achieved. But tissue separation requires lower energy than tissue sealing or coagulation. Also, the amount of tissue to be separated varies depending on, for example, the anatomical location of the blood vessel, the state of the tissue, and the type of surgery being performed.

[**0794**] One technique of treating a tissue that includes a blood vessel involves separating and moving the inner muscle layer of the blood vessel away from the adventitia layer prior to sealing and/or transecting the blood vessel. In order to more effectively separate the tissue layers of the blood vessel, a low level energy sufficient to separate but not coagulate or seal the tissue can be generated and transmitted to the tissue. Subsequently, a high level energy is employed to seal or coagulate the tissue.

[**0795**] A successful energy treatment of tissue grasped by an end effector depends on selecting a suitable energy mode of operation for each closure stage of the end effector. Furthermore, closure stages of an end effector may be determined by various situational parameters such as, for example, tissue type, anatomical location, and/or composition. Various suitable situational parameters are described under the heading "SITUATIONAL AWARENESS" in connection with FIG. 72.

[**0796**] Aspects of the present disclosure present various processes for selecting different energy modes for different closure stages of an end effector of an electrosurgical instrument. The selection can be based, at least in part, on one or more situational parameters.

[**0797**] In various aspects, the tissue interaction with the end effector during closure offers one or more situational parameters that can be useful in selecting, or adjusting, an energy mode for treating the tissue. FIG. 73 illustrates an end effector **131000** extending from a shaft **131001**, and undergoing closure motions to grasp tissue "T". The end effector **131000** includes a first jaw **131002** and a second jaw **131004**. At least one of the first jaw **131002** and the second jaw **131004** is movable relative to the other to grasp tissue therebetween. In various aspects, a closure stage can be defined by one or more angular positions of the first jaw **131002** relative to the second jaw **131004**, or one or more angular distances between the first jaw **131002** and the second jaw **131004**.

[**0798**] In the example of FIG. 73, the first jaw **131002** is movable relative to the second jaw **131004** to transition the end effector through different closure stages between an open configuration and a closed configuration to clamp tissue between the jaws **131002**, **131004**. FIG. 73 depicts two closure stages. In a first closure stage, the first jaw **131002** is moved an angular distance θ_1 from the open configuration.

[**0799**] The first closure stage is directly followed by a second closure stage extending an angular distance θ_2 from the open configuration of the end effector **131000**. Although only two closure stages are depicted in the example of FIG.

73, an end effector in accordance with the present disclosure may be transitioned through more or less than two closure stages.

[**0800**] FIGS. 75A and 75B are schematic diagrams of the end effector **131000** undergoing closure motions to separate, seal, and transect tissue "T". In FIG. 75A, the end effector **131000** is in a first closure stage, and an initial contact with the tissue "T" has been established. In FIG. 75B, the first jaw **131002** has completed the first closure stage, and is about to begin a second closure stage.

[**0801**] Referring to FIG. 74, a graph **131010** depicts a first therapeutic cycle **131012** applied to the tissue "T" of FIGS. 75A and 75B. Time is represented on the x-axis, while Amplitude is represented on the y-axis. The first therapeutic cycle **131012** comprises an initial tissue separation energy mode that achieves tissue separation in the first closure stage by applying a first energy to the tissue "T". The first therapeutic cycle **131012** further comprises a tissue sealing energy mode that achieves tissue sealing by applying a second energy, greater than the first energy, to the tissue "T" in the second closure stage.

[**0802**] A second therapeutic cycle **131014** is also depicted in the graph **131010** of FIG. 74. The second therapeutic cycle **131014** only comprises a tissue sealing energy mode. In other words, in the second therapeutic cycle **131014**, the tissue sealing energy mode does not follow an initial tissue separation energy mode. The second therapeutic cycle **131014** is suitable for use in certain situations where tissue separation is not needed.

[**0803**] FIG. 76 is a logic flow diagram of a process **131020** depicting a control program or a logic configuration for selecting an energy operational mode of an electrosurgical instrument. The process **131020** detects **131022** closure stages of the end effector **131000**. The process **131020** further selects **131024** between energy modes delivering different energy outputs based on the detected closure stages of the end effector **131000**. In one example, a first energy mode delivering a first energy output is selected in a first closure stage, while a second energy mode delivering a second energy output, greater than the first energy output, is selected in a second closure stage. The first energy output is sufficient to separate, but not seal, the tissue "T", while the second energy output is sufficient to seal the tissue "T".

[**0804**] In certain aspects, one or more of the processes of the present disclosure can be performed by a control circuit of the electrosurgical instrument such as, for example, the control circuit **710** of the surgical instrument **700**, the control circuit **760** of the surgical instrument **750**, and/or the control circuit **760** of the surgical instrument **790**. In certain aspects, as illustrated in FIG. 13, a control circuit **500** for performing one or more of the processes of the present disclosure may comprise one or more processors **502** (e.g., microprocessor, microcontroller) coupled to at least one memory circuit **504**, which stores program instructions, which, when executed by the processor **502**, cause the processor **502** to perform the one or more of the processes. Alternatively, one or more of the processes of the present disclosure can be performed by one or more of the control circuits depicted in FIGS. 14, 15. In certain aspects, an electrosurgical instrument may include a non-transitory storage medium storing one or more algorithms for performing one or more of the processes of the present disclosure.

[**0805**] FIG. 77 is another logic flow diagram of a process **131030** depicting a control program or a logic configuration

for selecting an energy operational mode of an electrosurgical instrument. The process **131030** selects an operational mode from operational modes delivering different energy outputs based on sensor signals indicative of closure stages of the end effector **131000**. In one example, the process of FIG. 77 is executed by a control circuit connected to one or more sensors configured to generate sensor signals indicative of the closure stages of the end effector **131000**. The sensor signals are received **131032** by the control circuit which selects an energy operational mode from operational modes delivering different energy outputs based on the received sensor signals. The control circuit, for example, determines **131034** whether the received sensor signals indicate that the end effector **131000** is in the first closure stage. If so, the control circuit selects a first operational mode causing a first energy output to be delivered **131036** to the tissue "T". If the received sensor signal does not indicate that the end effector is in the first closure stage, the control circuit further determines **131038** whether the received sensor signal indicates that the end effector **131000** is in the second closure stage. If so, the control circuit selects a second operational mode causing a second energy output, greater than the first energy output, to be delivered **131039** to the tissue "T".

[0806] In various exemplifications, the control circuit of the ultrasonic surgical instrument is configured to cause the transducer to change magnitude of the ultrasonic energy output in response to a transition of the clamp member from the first closure stage to the second closure stage.

[0807] In various exemplifications, the control circuit is configured to correlate a change in magnitude of the energy output to a transition from the first closure stage to the second closure stage. In various examples, the second energy output is sufficient for sealing and coagulating tissue, while the first energy output is sufficient for separating tissue but not sealing and coagulating tissue. Although only two energy operational modes are depicted in the example of FIG. 77, an electrosurgical instrument in accordance with the present disclosure may include more or less than two energy operational modes, each corresponding to a predetermined closure stage of the end effector **131000**. In various examples, the tissue separation mode is defined by a lower amplitude and/or frequency than that of the tissue coagulation and sealing mode.

[0808] FIG. 78 is another logic flow diagram of a process **131040** depicting a control program or a logic configuration for selecting an energy operational mode of the electrosurgical instrument. The process **131040** is similar in many respects to the process of FIG. 76. In addition, the process **131040** determines **131042** when an initial contact with the tissue "T" is achieved (See FIG. 75.A) as the first jaw **131002** is moved through the closure stages between the open configuration and the closed configuration. More specifically, the selection between the energy operational modes of the electrosurgical instrument is based on the closure stage in which the initial contact with the tissue "T" is detected.

[0809] In various aspects, the initial tissue contact can be detected by a tissue-contact circuit, which comprises first jaw electrodes and second jaw electrodes. The first jaw electrodes are coupled to one pole of an electrosurgical energy source and the second jaw electrodes are coupled to an opposite pole of the electrosurgical energy source. When tissue is simultaneously in contact with first jaw electrodes and the second jaw electrodes, the tissue-contact circuit is in

a closed configuration, allowing a non-therapeutic signal to pass between the jaws **131002**, **131004**. Accordingly, electrical continuity is established between the jaws **131002**, **131004** where tissue is located therebetween and no electrical continuity is established between the jaws **131002**, **131004** where no tissue is located therebetween.

[0810] In various aspects, the initial tissue contact is achieved when the jaws **131002**, **131004** exert sufficient compression on the tissue "T" captured therebetween to cause a sensing circuit "SC" to be closed.

[0811] FIG. 78A is a schematic illustration of an example tissue contact circuit showing the completion of the circuit upon contact with tissue to a pair of spaced apart contact plates. Contact of the jaws **131002**, **131004** with tissue "T" closes a sensing circuit "SC" that is otherwise open, by establishing contact with a pair of opposed plates "P1, P2" provided on the jaws **131002**, **131004**. Closure of the sensing circuit "SC" causes a sensor signal to be transmitted to a control circuit (e.g. FIGS. 13-14, 17-19). The sensor signal indicates that initial tissue contact has been established. FIG. 78A and additional exemplifications are further described in U.S. Pat. No. 8,181,839, filed Jun. 27, 2011, titled SURGICAL INSTRUMENT EMPLOYING SENSORS, which issued May 5, 2012, the entire disclosure of which is incorporated by reference herein.

[0812] FIG. 79 is another logic flow diagram of a process **131050** depicting a control program or a logic configuration for selecting an energy operational mode of an electrosurgical instrument based on the closure stage in which initial contact with the tissue "T" is detected. The process **131050** includes receiving **131052** first and second sensor signals. In one example, the process **131050** is executed by a control circuit (e.g. FIGS. 13-14, 17-19) connected to at least one first sensor configured to generate sensor signals indicative of the closure stages of the end effector **131000**. The control circuit is also connected to at least one second sensor configured to generate sensor signals indicative of detecting an initial contact with the tissue "T". Sensor signals from the first and second sensors are transmitted to the control circuit.

[0813] The process **131050** further determines **131054** whether the first sensor signals indicate that the end effector **131000** is in a first closure stage. If so, the process **131050** further determines **131056** whether the second sensor signals indicate that an initial tissue contact has been established.

[0814] If the first sensor signals indicate that the end effector **131000** is in a first closure stage, and the second sensor signals indicate that an initial tissue contact has been established, a first energy output is delivered **131058** to the tissue "T". In one example, the control circuit selects a first operational mode causing the first energy output to be delivered **131058** to the tissue "T".

[0815] Conversely, if the end effector **131000** is not in the first closure stage, the process **131050** further determines **131060** whether the end effector **131000** is in the second closure stage. If so, the process **131050** further determines **131062** whether the second sensor signals indicate that an initial tissue contact has been established in the second closure stage.

[0816] If the first sensor signals indicate that the end effector **131000** is in a second closure stage, and the second sensor signals indicate that an initial tissue contact has been established in the second closure stage, a second energy output, greater than the first energy output, is delivered

131064 to the tissue “T”. In one example, the control circuit selects a second operational mode causing the second energy output to be delivered **131064** to the tissue “T”.

[0817] In other words, a detection of an initial contact with the tissue in the first closure stage causes the control circuit to cause a first energy output to be delivered to the tissue “T”, while a detection of the initial contact with the tissue in the second closure stage causes the control circuit to cause a second energy output to be delivered to the tissue “T”. As described above, in various aspects, the second energy output is sufficient for sealing and coagulating tissue, while the first energy output is sufficient for separating tissue but not sealing and coagulating of tissue.

[0818] In various aspects, as described above in greater detail, a closure stage can be defined by an angular position, or a range of angular positions, of the first jaw **131002** relative to the second jaw **131004**. In certain instances, first and second closure stages can span predetermined portions of the maximum angular distance between the jaws **131002**, **131004** in the open configuration. An end effector **131000** completes a full closure cycle by moving the first jaw **131002** relative to the second jaw **131004** the maximum angular distance.

[0819] In one example, the first closure stage spans a first angular distance, and the second closure stage spans a second angular distance. In one example, the first and second angular distances are equal, or at least substantially equal. In one example, the second angular distance directly follows the first angular distance. Alternatively, in another example, the first angular distance is spaced apart from the second angular distance. In one example, the ratio of the first angular distance to the second angular distance is selected from a range of about one half to about two, for example.

[0820] In one example, the first closure stage spans the first half of the maximum angular distance, and the second closure stage spans the second half of the maximum angular distance. Accordingly, a detection of an initial tissue contact at any point up to 50% of the full closure cycle of the end effector **131000** yields the first energy output, in accordance with the process **131050**, while a detection of the initial tissue contact at a point beyond the 50% mark yields the second energy output.

[0821] Angular position is not the only identifying characteristic of a closure stage of the end effector **131000**. As described below in connection with FIG. **80**, closure motions of an end effector **131000** are driven by a longitudinally-movable drive member **131110**. Longitudinal position of the longitudinally-movable drive member **131110** is another identifying characteristic of a closure stage. The longitudinal movement of the longitudinally-movable drive member **131110** corresponds to the angular motion of the first jaw **131002** relative to the second jaw **131004**, and is monitored by an absolute positioning system **7000**.

[0822] In various examples, a control circuit (e.g. FIGS. **13-14**, **17-19**) of an electrosurgical instrument includes a storage medium storing, among other things, information characteristic of the closure stages of the end effector **131000** such as, for example, the start point of a closure stage, the end point of a closure stage, the angular position(s) of the first jaw **131002** that are associated with a closure stage, and/or the longitudinal position(s) of the longitudinally-movable drive member **131110** that are associated with a closure stage.

[0823] As illustrated in FIG. **80**, the absolute positioning system **7000** is configured to track closure of the end effector **131000**. Relying on the stored information and the output of the absolute positioning system **7000**, a control circuit (e.g. FIGS. **13-14**, **17-19**) of the electrosurgical instrument can determine the closure stages of the end effector **131000** as it transitions between the open configuration and the closed configuration.

[0824] In certain aspects, a drive system is configured to apply drive motions to motivate the end effector **131000** through the closure stages. The drive system may employ an electric motor **131102**. In various forms, the motor **131102** may be a DC brushed driving motor having a maximum rotation of, approximately, 25,000 RPM, for example. In other arrangements, the motor **131102** may include a brushless motor, a cordless motor, a synchronous motor, a stepper motor, or any other suitable electric motor. A battery **1104** (or “power source” or “power pack”), such as a Li ion battery, for example, may supply power to the control circuit and ultimately to the motor **131102**.

[0825] The electric motor **131102** can include a rotatable shaft **7016** that operably interfaces with a gear reducer assembly **7014** that is mounted in meshing engagement with a set, or rack, of drive teeth on a longitudinally-movable drive member **131110**. In use, a voltage polarity provided by the battery **1104** can operate the electric motor **131102** in a clockwise direction wherein the voltage polarity applied to the electric motor **131102** by the battery **1104** can be reversed in order to operate the electric motor **131102** in a counter-clockwise direction. When the electric motor **131102** is rotated in one direction, the longitudinally-movable drive member **131110** will be axially driven in the distal direction “D” causing the first jaw **131002** to move through the closure stages from the open configuration to the closed configuration. When the motor **131102** is driven in the opposite rotary direction, the drive member **131110** will be axially driven in a proximal direction “P” transitioning the first jaw **131002** back to the open configuration.

[0826] FIG. **80** is a schematic diagram of an absolute positioning system **7000** comprising a microcontroller **7004** controlled motor drive circuit arrangement comprising a sensor arrangement **7002**, according to one embodiment. The electrical and electronic circuit elements associated with the absolute positioning system **7000** and/or the sensor arrangement **7002** are supported by the control circuit board assembly. The microcontroller **7004** generally comprises a memory **7006** and a microprocessor **7008** (“processor”) operationally coupled thereto. The processor **7008** controls a motor driver **7010** circuit to control the position and velocity of the motor **131102**. The motor **131102** is operatively coupled to the sensor arrangement **7002** and an absolute position sensor **7012** arrangement to provide a unique position signal to the microcontroller **7004** for each possible location of longitudinally-movable drive member **131110** and, consequently, each possible location of the first jaw **131002**.

[0827] The unique position signal is provided to the microcontroller **7004** over feedback element **7024**. It will be appreciated that the unique position signal may be an analog signal or digital value based on the interface between the position sensor **7012** and the microcontroller **7004**. In one aspect, the interface between the position sensor **7012** and the microcontroller **7004** is standard serial peripheral interface (SPI) and the unique position signal is a digital value

representing the position of a sensor element **7026** over one revolution. The value representative of the absolute position of the sensor element **7026** over one revolution can be stored in the memory **7006**. The absolute position feedback value of the sensor element **7026** corresponds to the position of the first jaw **131002**.

[0828] In addition, other sensor(s) **7018** may be provided to measure other parameters associated with the absolute positioning system **7000**. One or more display indicators **7020**, which may include an audible component, also may be provided.

[0829] A sensor arrangement **7002** provides a unique position signal corresponding to the location of the longitudinally-movable drive member **131110**. The electric motor **131102** can include a rotatable shaft **7016** that operably interfaces with a gear assembly **7014** that is mounted in meshing engagement with a set, or rack, of drive teeth on the longitudinally-movable drive member **131110**. The sensor element **7026** may be operably coupled to the gear assembly **7014** such that a single revolution of the sensor element **7026** corresponds to some linear longitudinal translation of the longitudinally-movable drive member **131110**

[0830] The sensor arrangement **7002** for the absolute positioning system **7000** employs a position sensor **7012** which generates a unique position signal for each rotational position in a single revolution of a sensor element associated with the position sensor **7012**. Thus, a single revolution of a sensor element associated with the position sensor **7012** is equivalent to a longitudinal linear displacement d_1 of the longitudinally-movable drive member **131110**. In other words, d_1 is the longitudinal linear distance that the longitudinally-movable drive member **131110** moves from point "a" to point "b" after a single revolution of a sensor element coupled to the longitudinally-movable drive member **131110**. A series of switches **7022a** to **7022n**, where n is an integer greater than one, may be employed alone or in combination with gear reduction to provide a unique position signal for more than one revolution of the position sensor **7012**. The state of the switches **7022a-7022n** are fed back to the microcontroller **7004**, which applies logic to determine a unique position signal corresponding to the longitudinal linear displacement $d_1+d_2+\dots+d_n$ of the longitudinally-movable drive member **131110**, which corresponds to a unique position of the first jaw **131002** between the open configuration and the closed configuration.

[0831] In various aspects, the position sensor **7012** of the sensor arrangement **7002** may comprise one or more magnetic sensors, an analog rotary sensor like a potentiometer, an array of analog Hall-effect elements, which output a unique combination of position signals or values, among others, for example.

[0832] In various aspects, the motor **131102** is replaced with a hand trigger that manually drives the longitudinally-movable drive member **131110**. The hand trigger can be a part of a handle of the ultrasonic surgical instrument. In such aspects, the absolute positioning system **7000** is configured to track the manual advancement and retraction of the longitudinally-movable drive member **131110**.

[0833] In various aspects, the microcontroller **7004** may be programmed to perform various functions, such as precise control over the speed and position of the first jaw **131002**. Using the known physical properties, the microcontroller **7004** can be designed to determine the position of the first jaw **131002** and/or the rate of motion of the first jaw

131002 throughout its range of motion, which can be further utilized to determine a current closure stage of the first jaw **131002**. Additional details regarding the absolute positioning system are disclosed in U.S. patent application Ser. No. 13/803,210, titled SENSOR ARRANGEMENTS FOR ABSOLUTE POSITIONING SYSTEM FOR SURGICAL INSTRUMENTS, and filed Mar. 14, 2013, which is hereby incorporated by reference herein in its entirety.

[0834] In certain aspects, closure stages are defined or characterized by predetermined positions that can be stored in a storage medium of a control circuit (e.g. FIGS. **13-15**, **17-19**). The position sensor **7012** transmits sensor signals indicative of the position of the longitudinally-movable drive member **131110** along its range of motion to the control circuit. Since the position of the longitudinally-movable drive member **131110** corresponds to the position of the first jaw **131002**, the control circuit may assess a closure stage of the end effector **131000** based on the received sensor signals and the predetermined positions data stored in the storage medium.

[0835] For example, a first closure stage may span a first range of positions, while a second closure stage may span a second range of positions beyond the first range of positions. Accordingly, sensor signals from the position sensor **7012** indicating that the position of the longitudinally-movable drive member **131110** is within the first range of positions causes the processor **7008** to determine that the end effector **131000** is in the first closure stage and, consequently, causes a selection of a first energy operational mode. On the other hand, sensor signals from the position sensor **7012** indicating that the position of the longitudinally-movable drive member **131110** is within the second range of positions causes the processor **7008** to determine that the end effector **131000** is in the second closure stage and, consequently, causes a selection of a second energy operational mode different than the first energy operational mode. As discussed above, the second energy operational mode may yield a second energy output that is sufficient for sealing and coagulating tissue, while the first energy operational mode may yield a first energy output that is sufficient for separating tissue, but not sealing and coagulating of tissue.

[0836] Another identifying characteristic of closure stages of the end effector **131000** includes closure speed. The motor **131102** (FIG. **80**) can be configured to motivate the longitudinally-movable drive member **131110**, which drives the first jaw **131002**, at a constant speed. However, as the first jaw **131002** interacts with the tissue "T", the closure speed may vary depending on characteristics of the tissue "T" portions interacting with the first jaw **131002**. Accordingly, a change in closure speed can be an identifying characteristic of closure stages of the end effector **131000**. Closure speed may change as the end effector **131000** transitions from one tissue portion to another, such as, for example, a transition from a tissue portion suitable for tissue separation to a tissue portion suitable for tissue sealing. The change in the rate of motion of the first jaw **131002** can indicate completion of the tissue separation, which precedes the tissue sealing and coagulation.

[0837] In certain aspects, closure stages are defined or characterized by predetermined rates of motion that can be stored in a storage medium of a control circuit (e.g. FIGS. **13-15**, **17-19**). The rate of motion of the longitudinally-movable drive member **131110**, which corresponds to the rate of motion of the first jaw **131002**, can be determined

based on the sensor signals of the position sensor **7012**. In certain aspects, a change in the rate of motion of longitudinally-movable drive member **131110** indicates a transition from a first closure stage to a second closure stage, which may cause the control circuit to switch from the first energy operational mode to the second energy operational mode.

[0838] Another identifying characteristic of closure stages of the end effector **131000** includes clamp load. Like closure speed, the load exerted by the end effector **131000** on the tissue “T” may change depending on characteristics of the tissue “T” portions interacting with the first jaw **131002**. Accordingly, a change in clamp load can be an identifying characteristic of closure stages of the end effector **131000**. Clamp load may change as the end effector **131000** transitions from one tissue portion to another, such as, for example, a transition from a tissue portion suitable for tissue separation to a tissue portion suitable for tissue sealing. The change in the clamp load can indicate completion of the tissue separation, which precedes the tissue sealing and coagulation.

[0839] FIG. **81** is a logic flow diagram of a process **131070** depicting a control program or a logic configuration for switching between energy operational modes of an electro-surgical instrument, in accordance with at least one aspect of the present disclosure. The process **131070** comprises detecting **131072** closure speed and clamp load of an end effector **131000**. Closure speed can be monitored via the absolute positioning system **7000**. Clamp load can be determined using sensors **8406**, **8408a**, **8408b**, as described in connection with FIGS. **51**, **52**. The sensors **8406**, **8408a**, **8408b** are electrically connected to a control circuit such as the control circuit **7400** (FIG. **49**) via interface circuits. The process **131070** further includes determining **131074** whether the closure speed has changed beyond a predetermined threshold. A storage medium of the control circuit performing the process **131070** may store a value of the predetermined threshold. The current closure speed can be compared to the predetermined threshold to determine whether the current closure speed reaches or exceeds the predetermined threshold. The process **131070** also determines **131076** whether the clamp load has changed beyond a predetermined threshold. A storage medium of the control circuit performing the process **131070** may store a value of the predetermined threshold. The current clamp load can be compared to the predetermined threshold to determine whether the current clamp load reaches or exceeds the predetermined threshold. An occurrence of either of the two events causes the process **131070** to switch **131078** from a tissue separation energy mode to a tissue sealing energy mode.

[0840] In various instances, the end effector **131000** can be in the form of an ultrasonic end effector adapted for use with an ultrasonic surgical instrument **1104**, an RF end effector adapted for use with an RF electro-surgical instrument **1106**, or a combination end effector adapted for use with a multifunction surgical instrument **1108**, as described in connection with FIGS. **17-19**, **22-24**. Any of the instruments **1104**, **1106**, **1108** can be configured to perform one or more of the processes **131020**, **131030**, **131040**, **131050**, **131070**, as described above.

[0841] In examples where the end effector **131000** is in the form of an ultrasonic end effector, the jaws **131002**, **131004** can be in the form of a clamp member and an ultrasonic blade. The clamp member can be moved relative to the

ultrasonic blade to grasp tissue therebetween. As described above in greater detail, the ultrasonic generator may be activated to apply power to an ultrasonic transducer, which is acoustically coupled to the ultrasonic blade via an ultrasonic waveguide.

[0842] In various aspects, a first ultrasonic frequency may be set initially, during a first closure stage, to mechanically separate the muscle tissue layer of a vessel prior to applying a second ultrasonic frequency, during a second closure stage, to cut and seal the vessel.

[0843] An ultrasonic generator module is programmed to output a first drive frequency f_1 during a first closure stage, wherein the first frequency f_1 is significantly off resonance, for example, $f_0/2$, $2f_0$ or other structural resonant frequencies, where f_0 is the resonant frequency (e.g., 55.5 kHz). The first frequency f_1 provides a low level of mechanical vibration action to the ultrasonic blade that, in conjunction with the clamp force, mechanically separates the muscle tissue layer (sub-therapeutic) of the vessel without causing significant heating that generally occurs at resonance. During a second closure stage, the ultrasonic generator module is programmed to automatically switch the drive frequency to the resonant frequency f_0 to transect and seal the vessel.

[0844] In various aspects, the ultrasonic surgical instrument is connected to a surgical hub which interacts with a cloud based system, as described in connection with FIGS. **1-11**. In such instances, the control circuit of the electro-surgical instrument may receive input regarding various situational parameters collected by the surgical hub and/or the cloud based system. Such input can be useful in selecting a suitable energy mode of operation. Moreover, the energy levels generated by the transducer can be specifically adjusted to the type of tissue being treated. Situational parameters include, but not limited to, tissue type, tissue anatomical location, and/or tissue composition. For example, the energy required for tissue separation in liver or other solid organs can be different than other organs. Furthermore, energy levels for tissue separation can be increased to accommodate tissue adhesions or other errant connective tissue, as reported by the surgical hub. Additional details on situational awareness of the surgical hub, the cloud-based system, and various surgical instruments are described under the heading “SITUATIONAL AWARENESS.”

Controlling Different Electromechanical Systems of an Electro-surgical Instrument

[0845] Various surgical instruments include end effectors that clamp tissue and apply RF energy, ultrasonic energy, or a combination of RF energy and ultrasonic energy to the clamped tissue, as described in connection with FIGS. **22-24**. Optimal tissue treatment is achieved by carefully modulating energy application to tissue and tissue compression, which are achieved by separate systems that nonetheless influence each other’s effect on tissue. For example, energy application to tissue can be influenced by the tissue water content which is influenced by the compression applied to the tissue. Increasing the compression applied to tissue increases the speed by which the tissue water content egresses the tissue clamped by the end effector which, in turn, influences the tissue conductivity.

[0846] Aspects of the present disclosure provide various processes for modulating systems of an electro-surgical instrument that act separately on tissue but, nonetheless,

have interrelated impacts on the tissue. Using the same parameter to modulate separate systems of an electrosurgical instrument that have interrelated impacts on tissue ensures consistency of the systems' effect on the tissue. In other words, relying on the same parameter to coordinate the operation of such systems allows for a better-correlated effect on the tissue.

[0847] In certain aspects, one or more of processes of the present disclosure can be performed by a control circuit of an electrosurgical instrument such as, for example, the control circuit 710 of the surgical instrument 700 and/or the control circuit 760 of the surgical instruments 750, 790. In certain aspects, as illustrated in FIG. 13, a control circuit for performing the one or more processes may comprise one or more processors 502 (e.g., microprocessor, microcontroller) coupled to at least one memory circuit 504, which stores program instructions, which, when executed by the processor 502, cause the processor 502 to perform the one or more processes. Alternatively, the one or more processes can be performed by one or more of the control circuits depicted in FIGS. 14, 15. In certain aspects, an electrosurgical instrument may include a non-transitory storage medium storing one or more algorithms for performing the one or more processes.

[0848] FIG. 82 is a logic flow diagram of a process 131100 depicting a control program or a logic configuration for modulating systems of a surgical instrument (e.g. surgical instruments 700, 750, 790, 1104, 1106, 1108) in accordance with at least one aspect of the present disclosure. The process 131100 monitors 131101 a parameter of the surgical instrument. In various examples, the electrosurgical instrument includes an end effector 131000. In certain examples, the parameter is an impedance of tissue grasped by the end effector 131000. In another examples, the parameter is a temperature of the grasped tissue.

[0849] The process 131100 further causes a change 131104 in energy delivered to the tissue in response to reaching or crossing 131106 an upper predetermined threshold of the parameter. The process 131100 further causes a change 131108 in energy delivered to a motor (e.g. motors 603, 704a, 754) of the surgical instrument in response to reaching or crossing 131109 a lower predetermined threshold of the parameter. The motor is operably coupled to the end effector 131000 such that energy delivered to the motor causes the motor to transition the end effector 131000 toward the closed configuration. Accordingly, the process 131100 effects a change in end effector closure in response to reaching or crossing 131109 a lower predetermined threshold of the parameter.

[0850] In the example of FIG. 82, the change in end effector closure is accomplished by modifying the energy delivered to the motor. In other instances, the change in end effector closure can be achieved differently through a gear box assembly, for example. A clutch mechanism can be configured to engage or disengage the gear box assembly in order to increase or decrease the speed of a drive shaft couple to the motor and, in turn, cause the desired change in end effector closure.

[0851] In situations where tissue impedance (Z) is the monitored parameter, tissue impedance (Z) can be monitored by one or more sensors, as described in connection with the FIGS. 18, 19, 21, 78A. For example, the end effector 131000 can be equipped with the tissue contact

circuit of FIG. 78A where tissue "T" is grasped between the plates P1, P2. Tissue impedance (Z_{tissue}) can be calculated based on the formula:

$$Z_{tissue} = \frac{V}{I} - Z_{sense\ circuit}$$

wherein V is voltage, I is current, and $Z_{sense\ circuit}$ is a predetermined impedance of the sense circuit "SC", as illustrated in FIG. 78A. In various example, as illustrated in connection with FIG. 21, the tissue impedance (Z) may be measured by dividing the output of the second voltage sensing circuit 924 by the current sensing circuit 914.

[0852] In situations where tissue impedance (Z) is the monitored parameter, tissue impedance (Z) can be monitored by one or more temperature sensors. Alternatively, tissue temperature can be determined, as described above in connection with FIGS. 51-53, wherein a flexible circuit 8412 may comprise temperature sensors embedded in one or more layers of the flexible circuit 8412. The one or more temperature sensors may be arranged symmetrically or asymmetrically and provide tissue 8410 temperature feedback to control circuits of an ultrasonic drive circuit and/or an RF drive circuit. In other examples, as illustrated in connection with FIGS. 66A-66B, a change in phase angle ϕ and/or generator drive frequency can be used as an indirect or inferred measurement of the temperature of an ultrasonic blade, which, in turn, can be used to estimate or infer the temperature of tissue being grasped between the ultrasonic blade and the clamp member of an ultrasonic end effector.

[0853] FIG. 83 is another logic flow diagram of a process 131120 depicting a control program or a logic configuration for modulating systems of an electrosurgical instrument (e.g. surgical instruments 700, 750, 790, 1104, 1108) in accordance with at least one aspect of the present disclosure. The process 131120 monitors 131121 a parameter associated with the electrosurgical instrument. As described above in connection with the process 131120, the parameter can be an impedance or a temperature associated with the electrosurgical instrument. The process 131120 further causes a change 131124 in a first electromechanical system of the electrosurgical instrument in response to reaching or crossing 131126 an upper predetermined threshold of the parameter. The process 131120 further causes a change 131128 in a second electromechanical system of the electrosurgical instrument, different than the first electromechanical system, in response to reaching or crossing 131129 a lower predetermined threshold of the parameter.

[0854] FIG. 84 is a graph 131130 illustrating implementation of the process 131120 in connection with an ultrasonic surgical instrument that includes the ultrasonic end effector 1122 of FIG. 23, for example. The first electromechanical system is represented by the transducer 1120 and the ultrasonic blade 1128, which is acoustically coupled to the ultrasonic transducer 1120 via a waveguide. The ultrasonic transducer 1120 can be energized with the generator 1100. When driven by the ultrasonic transducer 1120, the ultrasonic blade 1128 may vibrate and, when brought into contact with tissue, may cut and/or coagulate the tissue, as described herein.

[0855] The second electromechanical system is represented by a motor-driven clamp arm 1140 of the end effector 1122. Motorized movement of a clamp arm of an ultrasonic

surgical instrument is described in greater detail in connection with FIGS. 46-50. The clamp arm 1140 can be operably coupled to a motor, which may drive the clamp arm 1140 to transition the end effector 1122 between an open configuration and a closed configuration to grasp tissue between the clamp arm 1122 and the ultrasonic blade 1128.

[0856] Referring to FIG. 84, the graph 131130 includes three graphs 131132, 131134, 131136 illustrating the tissue impedance (Z), power (P), and force (F) plotted on the Y-axis against time (t) on the X-axis. The force (F) is determined at a distal portion (tip) of the end effector 1122. Upper and lower thresholds are defined in the impedance graph 131132. At t_1 and t_4 , power (P) is adjusted in the power graph 131134, as the impedance (Z) reaches or crosses the upper threshold defined in the impedance graph 131132. Accordingly, the energy delivered to the transducer 1120 of the first electrosurgical system is governed by the upper threshold of the impedance (Z) parameter. At t_2 and t_3 , tip forces (F) are adjusted in the force graph 131136 as the impedance value reaches or crosses the lower threshold defined in the impedance graph 131132. Accordingly, the forces exerted by the clamp member 1122 onto the tissue are governed by the lower threshold of the impedance (Z) parameter.

[0857] In various example, the current (I) delivered to the motor can be changed, as the tissue impedance (Z) reaches or crosses the lower threshold, in order to effect a change in the forces exerted by the clamp member 1122 onto the tissue. In at least one example, the motor current (I) can be increased to increase clamp forces applied to the tissue as tissue impedance (Z) reaches or crosses the lower predetermined threshold, as illustrated in FIG. 84.

[0858] Due to the pivoting motion of the clamp arm of an ultrasonic surgical instrument, more tissue compression is applied to tissue positioned proximally between the jaws than tissue positioned distally between the jaws. The decreased tissue compression at a distal portion of the jaws may reduce heat flux to the tissue at the distal portion of the jaws below a threshold level necessary for an effective treatment of the tissue.

[0859] In various aspects, the clamp arm can be equipped with tissue sensing circuits configured to determine location of the tissue clamped between the jaws of an end effector. Examples of suitable tissue sensing circuits are described in U.S. Pat. No. 8,181,839, filed Jun. 27, 2011, titled SURGICAL INSTRUMENT EMPLOYING SENSORS, which issued May 5, 2012, the entire disclosure of which is incorporated by reference herein. Various tissue sensing techniques are also described in U.S. Provisional Application No. 62/650,887, titled SURGICAL SYSTEMS WITH OPTIMIZED SENSING CAPABILITIES, and filed Mar. 30, 2018, which is hereby incorporated by reference herein in its entirety. In at least one example, a tissue sensing circuit includes two electrodes spaced apart. When tissue is in contact with the two electrodes the tissue sensing circuit is closed, causing a sensor signal indicative of the presence of tissue to be transmitted to a control circuit (e.g. FIGS. 13-14, 17-19).

[0860] The clamp arm load can be adjusted based on the detected tissue location. For example, a higher load can be applied in situations where tissue is concentrated at a distal portion of the jaws. The higher clamp arm load can be sustained until the clamped tissue at the distal portion of the jaws is nearly fully coagulated. The clamp arm load is then

reduced to avoid driving the ultrasonic blade into the pad of the clamp arm. In one example, the higher clamp arm load can be sustained up to predetermined angular distance between the clamp arm and the ultrasonic blade. Once the clamp arm reaches or crosses the predetermined angular distance, the clamp arm load is reduced.

[0861] In certain aspects, in connection with a combo device, RF energy can be blended with the modulation of clamp arm load in order to provide sufficient heat flux to coagulate tissue concentrated at a distal end portion of jaws.

Detection of End Effector Emersion in Liquid

[0862] The frequency response associated with immersion of the ultrasonic blade into a liquid is analogous to that associated with a thick tissue clamped between the clamp member and the ultrasonic blade. To avoid mistakenly triggering a tissue treatment by the generator that is specific to thick tissue, it is desirable to detect when the ultrasonic blade is immersed in a liquid.

[0863] As described above in connection with FIGS. 70A-71, an ultrasonic surgical instrument, or a combination electrosurgical instrument including an ultrasonic component, is configured to detect immersion of its ultrasonic blade in a liquid (e.g., blood, saline, water, etc.) by detecting a temperature of the ultrasonic blade significantly below a predetermined threshold.

[0864] As previously described, the temperature of the ultrasonic blade may be inferred by detecting the impedance of the ultrasonic transducer given by the following expression:

$$Z_g(t) = \frac{V_g(t)}{I_g(t)}$$

[0865] or equivalently, detecting the phase angle φ between the voltage $V_g(t)$ and current $I_g(t)$ signals applied to the ultrasonic transducer. The phase angle φ information also may be used to infer the conditions of the ultrasonic blade. As discussed with particularity herein, the phase angle φ changes as a function of the temperature of the ultrasonic blade. Therefore, the phase angle φ information may be employed to control the temperature of the ultrasonic blade.

[0866] FIGS. 70A-70B are graphical representations of temperature feedback control for adjusting ultrasonic power applied to an ultrasonic transducer when a sudden drop in temperature of an ultrasonic blade is detected. The temperature of the ultrasonic blade increases with the application of power 133072 as shown in FIG. 70A. During use, the temperature of the ultrasonic blade suddenly drops. It may be inferred that the temperature of the ultrasonic blade drops when it is immersed in a fluid-filled surgical field (e.g., blood, saline, water, etc.).

[0867] The immersion of the ultrasonic blade into the liquid causes a percentage of the heat produced by the ultrasonic blade to be lost to the liquid. Accordingly, the immersion increases the heat flux necessary to deliver an effective treatment, such as tissue coagulation. To modulate the heat flux to a level sufficient to deliver the effective treatment, the generator modulates the power delivered to the ultrasonic transducer.

[0868] In certain instances, a blend of RF energy and ultrasonic energy may be employed to adjust the heat flux to

a level sufficient to deliver the effective treatment. In certain instances, the compression forces applied to the tissue between the ultrasonic blade and the clamp arm of the surgical instrument can be modulated to adjust the heat flux to a level sufficient to deliver the effective treatment.

[0869] In another aspect, as illustrated in FIG. 85, detection of an immersion of the ultrasonic blade into a liquid can be inferred from the frequency response of the wave guide/transducer.

[0870] Referring to FIG. 85, power (P) is plotted as a function of time in a diagnostic mode, as illustrated in graph 131140, and in a response mode, as illustrated in graph 131142. Power (P) is plotted on the vertical axis while time (t) is plotted on the horizontal axis. The frequency response of the wave guide/transducer in a liquid is different than an ideal frequency response of the waveguide/transducer in air, and is below a predetermined threshold curve 131141. The frequency response curve 131143 of the wave guide/transducer is flattened when the ultrasonic blade is immersed in a liquid rather than having the characteristic increases and flat areas expected in an ideal frequency response curve 131145 that delivers an effective tissue treatment.

[0871] FIG. 86 is a logic flow diagram of a process 131150 depicting a control program or a logic configuration to detect and compensate for immersion of an ultrasonic blade into a liquid in accordance with at least one aspect of the present disclosure. The process 131150 monitors 131152 power delivered to tissue over time, and compares it to a predetermined threshold. As illustrated in FIG. 85, the process 131150 may sample the change in power over predetermined time periods ($\delta P/\delta t$), and compare it to the predetermined threshold slope. If the determined slope ($\delta p/\delta t$) is below the threshold slope, it is inferred that the ultrasonic blade is immersed in a liquid that dampens/cooling the blade, increasing the head flux necessary for the blade to deliver an effective treatment (curve 131145). To compensate 131156, more power (curve 131147) is delivered to the transducer. The added power is selected to be sufficient to yield the ideal frequency response (curve 131145) when adjusted by the dampening effect of the liquid. If, however, the determined slope ($\delta p/\delta t$) is greater than the threshold slope, power delivery to the ultrasonic transducer continues as planned.

[0872] As illustrated in graph 131142 of FIG. 85, a modified power curve 131147 is delivered to tissue in response to detecting that the ultrasonic end effector is immersed in fluid. The modified power curve 131147 compensates for the liquid immersion. In the example of graph 131142 the modified power (P) curve 131147 increases the power delivered to the transducer by a predetermined factor/percentage in order to achieve the desired power curve 131145.

[0873] In another aspect, detection of an immersion of an end effector into a liquid can be determined by a liquid sensing circuit in the end effector. The liquid sensing circuit may include two electrodes on the end effector which can be positioned on separate jaws. Alternatively, the electrodes could be positioned on the same jaw. The presence of liquid between the electrodes completes the circuit transmitting a signal, which can be used to detect immersion of the end effector in liquid. In response to the detection, as described above, the power delivered to the ultrasonic transducer can be modulated to compensate for the dampening/cooling effect of the end effector immersion in the liquid.

[0874] Depending on the degree an end effector is immersed in a liquid and/or the temperature of the liquid, an

algorithm can be selected to compensate for the heat lost to the liquid in order to achieve an effective treatment of the tissue. In at least one example, power (P) delivered to an ultrasonic transducer can be modulated, as described above, to counter the effects of immersion. Alternatively, compression forces can be applied to the tissue between the clamp arm and the ultrasonic blade to counter the effects of immersion. In various aspects, both power (P) and tissue compression can be modulated to counter the effects of liquid immersion. Blended RF and ultrasonic energy modes can also be used to minimize the effects of immersion and could be used in combination with increasing the ultrasonic power, the RF power, or the clamp arm pressure to achieve an effective treatment of the tissue.

[0875] Referring to FIG. 87, a graph 131160 depicts power (P) delivered to tissue by an end effector 131000 (FIG. 73) of an electrosurgical instrument and temperature (T) of the tissue grasped by the end effector 131000 as functions of displacement of a closure driver (e.g. closure member 764 of FIGS. 18, 19) that controls transition of the end effector 131000 to a closed configuration. As described herein, the end effector 131000 treats tissue by grasping tissue and applying an RF energy and/or an ultrasonic energy to the grasped tissue.

[0876] Further to the above, the closure driver is operably coupled to at least one of the jaws 131002, 131004, and is movable to transition the end effector 131000 between an open configuration and a closed configuration to clamp tissue between the jaws 131002, 131004. Accordingly, movement of the closure driver may represent, or correlate with, closure motions of the end effector 131000. Accordingly, a correlation exists between compression forces applied by the end effector 131000 to the tissue captured between the jaws 131002, 131004 and the closure driver displacement.

[0877] The graph 131160 represents a tissue treatment cycle of the end effector 131000. Power (P) is represented on the left vertical axis, temperature (T) is represented on the right vertical axis, and closure driver displacement or translation (δ) is represented on the horizontal axis. Each δ on graph 131160 on the horizontal axis represents a distance travelled by the closure driver from a starting position.

[0878] Stages of the tissue treatment cycle are defined by closure driver positions. In various aspects, it is desirable to maintain the tissue at a desired temperature, or range of desired temperatures, at one or more of the stages of the tissue treatment cycle. power (P) delivered to the tissue can be adjusted to maintain a tight control over the temperature of the tissue.

[0879] In the example of FIG. 87, an initial stage 131162 depicts a gradual increase in Power (P) toward the power level (P1) as the closure driver translates toward $\delta 1$. Power (P) is then maintained at a power level (P1) in a first stage 131164 corresponding to a temperature of about 60° C. At such temperature, the tissue experiences a denaturation of collagen. Toward the end of the first stage 131164, the power level is raised again to a power level (P2) corresponding to a temperature between 60° C. and 100° C. at the beginning of a second stage 131166. Toward the end of the second stage 131166, the power level is raised again toward a power level (P4) configured to cause the tissue to reach and/or exceed a temperature of 100° C.

[0880] On the horizontal axis, the first stage 131164 is defined between a first position at 61 and a second position

at $\delta 2$. Power (P) is maintained at the power level (P1) as the closure driver translates toward the second position at $\delta 2$. Tissue temperature is sustained at 60° C. to facilitate denaturation of collagen.

[0881] The second stage 131166 is defined between the second position at $\delta 2$ and a third position at $\delta 3$. Power (P) is maintained at the power level (P2) as the closure driver translates toward the third position at $\delta 3$. During the second stage 131166, it is desirable to maintain the tissue temperature between 60° C. and 100° C. in effort to avoid collateral damage to surrounding tissue that may be caused by the resulting steam at 100° C. In certain instances, however, as illustrated by the curve portion 131168 of the graph 131160, tissue temperature may prematurely rise to 100° C. before the closure driver reaches δ_{max} . In various aspects, as illustrated in FIG. 87, a predetermined power threshold (P3) is set to prevent the tissue from prematurely reaching the boiling temperature of 100° C.

[0882] FIG. 88 is a logic flow diagram of a process 131170 depicting a control program or a logic configuration to maintain tissue temperature below 100° C. as the clamp arm transitions to a closed configuration at δ_{max} . The process 131170 monitors 131172 closure driver position and/or displacement. In one example, the closure tube position and/or displacement can be monitored through an absolute positioning system 7000, as described in greater detail in connection with FIG. 80.

[0883] The process 131170 also monitors 131172 tissue temperature, which can be estimated based on temperature of the ultrasonic blade, for example. In the event the end effector 131000 is in the form of an ultrasonic end effector, or a combination end effector, the ultrasonic blade temperature can be determined by detecting the impedance of the ultrasonic transducer given by the following expression:

$$Z_g(t) = \frac{V_g(t)}{I_g(t)}$$

[0884] or equivalently, detecting the phase angle φ between the voltage $V_g(t)$ and current $I_g(t)$ signals applied to the ultrasonic transducer, as described herein. Alternatively, the end effector 131000 can be equipped with one or more temperature sensors for measuring tissue temperature.

[0885] Based on the monitored temperature and position information, the process 131170 determines 131174 if the temperature of the tissue will prematurely reach or exceed 100° C. before the closure driver reaches or passes δ_{max} , as illustrated by curved portion 131168 of graph 131160. If so, the process 131170 adjusts 131176 the power (P) to a level that is below or equal to the predetermined power threshold (P3) in order to keep the temperature (T) of the tissue from reaching 100° C. before the closure driver reaches or passes δ_{max} , as illustrated in curve portion 131169.

[0886] In certain aspects, the process 131170 can be executed, at least in part, by a control circuit (FIG. 13) that comprises one or more processors 502 (e.g., microprocessor, microcontroller) coupled to at least one memory circuit 504, which stores program instructions, which when executed by the processor 502, cause the processor 502 to perform the process 131170. The control circuit may receive closure-driver position information from the absolute positioning system 7000, for example. Tissue temperature can be ascer-

ained by the processor 502 from temperature sensor readings, or the determined ultrasonic blade temperature, as described herein.

[0887] Further to the above, determining 131174 whether the temperature of the tissue will prematurely reach or exceed 100° C. before the closure driver reaches or passes δ_{max} can be accomplished, for example, by calculating a temperature trajectory from position, power, and/or temperature data at the end of the second stage 131166. In one example, a processor 502 can be employed to calculate the temperature trajectory from one or more tables and/or equations stored in the memory circuit 504, for example.

[0888] In various aspects, the process 131170 can be performed by one or more of the control circuits depicted in FIGS. 14, 15. In certain aspects, an electrosurgical instrument may include a non-transitory storage medium storing one or more algorithms for performing process 131170.

[0889] In at least one example, as illustrated in FIG. 87, reaching or exceeding a predetermined threshold temperature T_1 , which is between 60° C. and 100° C., at a predetermined threshold position $\delta 3$, which is less than δ_{max} , can indicate that the temperature of the tissue will prematurely reach or exceed 100° C. before the closure driver reaches or passes δ_{max} . Accordingly, if the determined temperature is greater than or equal the predetermined threshold temperature T_1 at the predetermined position threshold $\delta 3$, the process 131170 determines 131174 that the temperature of the tissue will prematurely reach or exceed 100° C. before the closure driver reaches or passes δ_{max} .

[0890] Referring to FIG. 89, a graph 131180 comprises four graphs 131182, 131184, 131186, 131188. Graph 131182 represents voltage (V) and current (I) versus time (t), graph 131184 represents power (P) versus time (t), graph 131186 represents temperature (T) versus time (t), and graph 131188 represents tissue impedance (Z) versus time (t). In the graph 131188, an impedance bath tub (e.g., the tissue impedance versus time initially decreases, stabilizes, and finally increases and the curve resembles a bath tub shape) is depicted.

[0891] Here, time zero represents the first point at which electrosurgical energy is applied to the tissue at a surgical site. The Y-axis represents the level of tissue impedance (Z) present when a substantially constant level of power (P) is applied to the tissue, as illustrated in corresponding portion of graph 131184. At time zero, the tissue exhibits an initial level of impedance (Z_{init}). The initial level of impedance (Z_{init}) may be based on native physiological properties about the tissue, such as density, amount of moisture, and what type of tissue it is. Over a short period of time, the level of impedance actually dips slightly as power is continuously applied to the tissue. A minimum level of impedance (Z_{min}) is eventually reached. From here, the overall level of impedance increases.

[0892] As tissue impedance (Z) decreases, toward the minimum tissue impedance (Z_{min}) at time (t_1), current (I) increases and voltage (V) decreases. The current curve depicted in the graph 131182 corresponds to the voltage curve L1. The current curves corresponding to the voltage curves L2 and L3 are omitted for clarity. During the initial time period (t_1), the temperature of the tissue gradually rises toward 100° C. Once the water in the tissue begins to evaporate, tissue impedance (Z) increases significantly causing a decay in the current (I) passing through the tissue. As

tissue impedance (Z) rises toward 100Ω , tissue temperature also rises toward 110°C ., which constitutes a boiling point for certain tissue oils.

[0893] To achieve an effective tissue treatment, it is desirable to maintain the tissue below a predetermined maximum temperature. To prevent the temperature of the tissue from exceeding the predetermined maximum threshold temperature, voltage (V) is stepped up as indicated in the voltage (V) curves L2 and L3. The increase in the voltage (V) prevents the temperature of the tissue from exceeding the predetermined threshold temperature, as indicated in the temperature curve L3", which corresponds to the voltage curve L3, or at least quickly return the temperature of the tissue below the predetermined threshold temperature, as indicated in the temperature curve L2", which corresponds to the voltage curve L2. By comparison, where the voltage (V) is not increased, as indicated in the voltage curve L1, the tissue temperature of the tissue significantly rises beyond the predetermined threshold temperature, as indicated in corresponding temperature curve L1".

[0894] In at least one example, as illustrated in FIG. 89, the predetermined maximum temperature is about 130°C . To maintain the tissue below the predetermined maximum temperature, the voltage (V) is stepped up in order to slow down further increase in temperature, and ultimately reverse the increase in temperature.

[0895] In the example of FIG. 89, the tissue temperature reaches about 110°C . as tissue impedance (Z) reaches 100Ω , and the tissue temperature (T) reaches about 130°C . as tissue impedance (Z) reaches 4500 .

[0896] Processes 131190 (FIG. 90) and 131200 (FIG. 91) depict control programs or logic configurations that employ such values of tissue impedance (Z) and temperature (T) as trigger conditions for stepping up the voltage (V) toward the end of a tissue treatment cycle applied by an end effector 131000, as illustrated in FIG. 89. Other values of tissue impedance (Z) and tissue temperature (T) that can be employed as trigger conditions for stepping up the voltage (V) are contemplated by the present disclosure. In various examples, as illustrated in graph 131188 of FIG. 89, the threshold tissue impedance (Z) can be about 100Ω . In other examples, the threshold tissue impedance (Z) can be about 450Ω . In various examples, as illustrated in graph 131186 of FIG. 89, the threshold temperature (T) can be about 110°C . In other examples, the threshold temperature (T) can be about 130°C .

[0897] In one example, as illustrated in process 131190 of FIG. 90, tissue impedance (Z) can be monitored 131192, and used to determine 131194 when to trigger the voltage (V) increase 131196. As described herein in connection with FIG. 78A, for example, a sense circuit can be utilized to determine tissue impedance (Z). Control circuits (e.g. FIGS. 13-15) of an ultrasonic drive circuit and/or an RF drive circuit can be utilized to perform the process 131190 based on input received from the sense circuit.

[0898] In another example, as illustrated in process 131200 of FIG. 91, tissue temperature (T) can be monitored 131202, and used to determine 131204 when to trigger the voltage (V) increase 131206. As described herein in connection with FIGS. 66A-68, the generator infers the temperature of the ultrasonic blade based on the phase angle φ between the voltage $V_g(t)$ and current $I_g(t)$ signals applied to drive the ultrasonic transducer. Alternatively, tissue temperature can be determined, as described above in connec-

tion with FIGS. 51-53, wherein a flexible circuit 8412 may comprise temperature sensors embedded in one or more layers of the flexible circuit 8412. The one or more temperature sensors may be arranged symmetrically or asymmetrically and provide tissue 8410 temperature feedback to control circuits (e.g. FIGS. 13-15) of an ultrasonic drive circuit and/or an RF drive circuit. The control circuits can be utilized to perform the process 131200 based on the temperature feedback.

[0899] In various examples, the voltage (V) is increased in a stepwise manner, as indicated in the voltage curves L2, L3. In other examples, the voltage (V) can be gradually increased.

[0900] In at least one example, two different upper boundary temperatures are set to effect power level. Primary and secondary minimum shut off temperature thresholds can be employed in addition to the maximum temperature threshold.

Combination Ultrasonic and Radiofrequency Surgical Instruments

[0901] As described above, an end effector 131000 (FIG. 73) can be adapted for use with a combo electrosurgical instrument that provides tissue treatment through application of radiofrequency (RF) energy alone or in combination with ultrasonic vibrations. Examples of generators configured to drive the ultrasonic transducer and RF electrodes of an end effector are discussed in greater detail in U.S. Patent Publication No. 2017/0202609, entitled "Modular Battery Powered Hand-Held Surgical Instrument With Curved End Effectors Having Asymmetric Engagement Between Jaw and Blade," the entirety of which is incorporated by reference.

[0902] In various aspects, an end effector 131000, which includes an ultrasonic component and an RF component, is configured to modulate one or more parameters of the RF component based on tissue temperature measurements performed by the ultrasonic component. Accordingly, the ultrasonic component can be utilized in a non-therapeutic diagnostic mode while the RF component is utilized in a therapeutic mode, to adjust, in real time, one or more parameters of the RF component.

[0903] FIG. 92 is a process 131210 depicting a control program or a logic configuration for utilizing the ultrasonic component in a non-therapeutic diagnostic mode while the RF component is being utilized in a therapeutic mode.

[0904] The process 131210 monitors 131212 temperature of the ultrasonic blade. The process 131210 further determines 131214 whether the temperature of the ultrasonic blade is greater than or equal to a predetermined threshold temperature. If so, the process 131210 adjusts the power (P) of the RF component to reduce the energy delivered to the tissue.

[0905] As described in connection with FIGS. 66A-68, the generator infers the temperature of the ultrasonic blade based on the phase angle φ between the voltage $V_g(t)$ and current $I_g(t)$ signals applied to drive the ultrasonic transducer. Since the temperature of the ultrasonic blade corresponds to the temperature of the tissue captured by the end effector 131000 of the combo device, the ultrasonic component can be utilized in the diagnostic non-therapeutic mode to monitor the tissue temperature and provide feedback for adjusting the power level of the RF component.

[0906] FIG. 93 is a graph 131220 illustrating execution of the process 131210, in accordance with at least one aspect of the present disclosure. The graph 131220 comprises three graphs 131222, 131224, 131226, depicting power (P), temperature (T), and phase, respectively, on the vertical axis. Graph 131222 represents power (P) delivered to tissue captured between jaws 131002, 131004 of an end effector 131000 of a combo device versus time (t). Graph 131224 represents temperature (T) of the ultrasonic blade of the end effector 131000 versus time (t). Graph 131226 represents dual non-therapeutic frequencies employed by the ultrasonic component to determine temperature of the ultrasonic blade, and in turn, temperature of the tissue, as described in greater detail in connection with FIGS. 66A-68. The ultrasonic component can be configured to detect a tissue temperature transition to or across a predetermined threshold temperature ($T_{threshold}$), as illustrated in the graph 131224. The power (P) level of the RF component can then be adjusted (P1 to P2) to prevent exceedingly high temperatures, as illustrated in the graph 131222.

[0907] In at least one example, the power (P) level of the RF component is adjusted to maintain the tissue temperature below 100° C. to prevent steam from causing collateral damage to surrounding tissue while still locally coagulating collagen in the tissue grasped by the end effector 131000 of the combo device. In at least one example, the power (P) level of the RF component is adjusted to maintain the tissue temperature below 130° C. to prevent tissue charring that may occur at such temperature. In at least one example, the temperature feedback provided by the ultrasonic component allows the RF component to adjust power ramp rates in accordance with tissue phase transitions during a tissue treatment cycle.

[0908] In various aspects, a process comprises a control program or a logic configuration for distinguishing between sections of an ultrasonic blade based on temperature. The process separates very hot small sections from moderately hot larger sections of the ultrasonic blade. In at least one aspect, the process includes applying multiple frequencies through the 55.5 KHz, which is a standard frequency, and then alternatively using a 3× frequency of 150 KHz, for example, to determine two different resonate frequencies that would allow for determination of a small portion of the ultrasonic blade with a very hot temperature, or a larger portion of the ultrasonic blade with a moderately hot temperature.

[0909] FIG. 94 is a logic flow diagram of a process 131230 depicting a control program or a logic configuration for adjusting frequency of RF waveform of an RF electrosurgical instrument or an RF component of a combo device based on measured tissue impedance, in accordance with at least one aspect of the present disclosure. In at least one example, tissue impedance is measured 131232 prior to, or during an initial part of a tissue treatment cycle, and the measurement is used to choose 131231 between predetermined high 131234 and low frequency 131236 options of the RF waveform applied to the tissue.

[0910] The process 131230 addresses low power transmission conditions. If it is determined that measured tissue impedance is equal to or below a predetermined threshold, the high frequency RF waveform is selected for the treatment cycle. The high frequency RF waveform is configured to drive the tissue impedance higher to address low power transmission. If, however, it is determined that measured

tissue impedance is greater than or equal to a predetermined threshold, the low frequency RF waveform is selected for the treatment cycle. In various aspects, tissue impedance can be measured by one or more sensors, as described in connection with the FIGS. 18, 21, 78A.

[0911] In various aspects, one or more of the processes of the present disclosure can be performed by a control circuit of the electrosurgical instrument such as, for example, the control circuit 710 of the surgical instrument 700, the control circuit 760 of the surgical instrument 750, and/or the control circuit 760 of the surgical instrument 790. In certain aspects, as illustrated in FIG. 13, a control circuit for performing one or more of the processes of the present disclosure may comprise one or more processors 502 (e.g., microprocessor, microcontroller) coupled to at least one memory circuit 504, which stores program instructions, which when executed by the processor 502, cause the processor 502 to perform the one or more of the processes. Alternatively, one or more of the processes of the present disclosure can be performed by one or more of the control circuits depicted in FIGS. 14, 15. In certain aspects, an electrosurgical instrument may include a non-transitory storage medium storing one or more algorithms for performing one or more of the processes of the present disclosure.

[0912] Various aspects of the subject matter described herein are set out in the following numbered examples:

Example 1

[0913] A surgical instrument comprising an end effector, comprising an ultrasonic blade and a clamp arm. The clamp arm is movable relative to the ultrasonic blade to transition the end effector through different closure stages between an open configuration and a closed configuration to clamp tissue between the ultrasonic blade and the clamp arm. The surgical instrument further comprises a transducer configured to generate an ultrasonic energy output, a waveguide configured to transmit the ultrasonic energy output to the ultrasonic blade, and a sensor configured to transmit sensor signals indicative of the closure stages of the end effector. The surgical instrument further comprises a control circuit configured to receive the sensor signals and select an operational mode from operational modes delivering different ultrasonic energy outputs from the transducer based on the received sensor signals.

Example 2

[0914] The surgical instrument of Example 1, wherein the operational modes comprise a low energy operational mode configured to cause tissue separation but not tissue coagulation and a high energy operational mode configured to cause the tissue coagulation.

Example 3

[0915] The surgical instrument of Examples 1 or 2, wherein the closure stages comprise an initial closure stage spanning an initial portion of the clamp arm range of motion up to a predetermined threshold.

Example 4

[0916] The surgical instrument of Example 3, wherein the control circuit is configured to select a first operational mode delivering a first ultrasonic energy output in the initial closure stage.

Example 5

[0917] The surgical instrument of Example 4, wherein the control circuit is configured to switch to a second operational mode delivering a second ultrasonic energy output greater than the first ultrasonic energy output beyond the predetermined threshold.

Example 6

[0918] The surgical instrument of any one of Examples 1-5, wherein the selection between operational modes is further based on at least one situational parameter.

Example 7

[0919] The surgical instrument of Example 6, wherein the at least one situational parameter comprises type of the tissue.

Example 8

[0920] The surgical instrument of Examples 6 or 7, wherein the at least one situational parameter comprises anatomical location of the tissue.

Example 9

[0921] The surgical instrument of any one of Examples 6-8, wherein the at least one situational parameter comprises composition of the tissue.

Example 10

[0922] The surgical instrument of any one of Examples 1-9, wherein each of the closure stages is defined by a range of angular distances between the clamp arm and the ultrasonic blade.

Example 11

[0923] The surgical instrument of any one of Examples 1-10, further comprising a drive member configured to motivate the clamp member to move through the closure stages, and wherein each of closure stages is defined by a range of positions of the drive member.

Example 12

[0924] A surgical instrument comprising an end effector, comprising an ultrasonic blade and a clamp arm. The clamp arm is movable relative to the ultrasonic blade to transition the end effector through different closure stages between an open configuration and a closed configuration to clamp tissue between the ultrasonic blade and the clamp arm. The closure stages comprise a first closure stage and a second closure stage after the first closure stage. The surgical instrument further comprises a transducer configured to generate an ultrasonic energy output, a waveguide configured to transmit the ultrasonic energy output to the ultrasonic blade, and a sensor circuit configured to transmit a sensor signal indicative of detecting an initial contact of the clamp arm with the tissue. The surgical instrument further comprises a control circuit configured to receive the sensor signal, cause the transducer to generate a first ultrasonic energy output in response to receiving the sensor signal in the first closure stage, and cause the transducer to generate

a second ultrasonic energy output greater than the first ultrasonic output in response to receiving the sensor signal in the second closure stage.

Example 13

[0925] The surgical instrument of Example 12, wherein the control circuit is further configured to cause the transducer to switch from the first ultrasonic energy output to the second ultrasonic energy output in response to a transition from the first closure stage to the second closure stage.

Example 14

[0926] The surgical instrument of Examples 12 or 13, wherein the first ultrasonic energy output is configured to cause tissue separation but not tissue coagulation, and wherein the second ultrasonic energy output is configured to cause the tissue coagulation.

Example 15

[0927] The surgical instrument of any one of Examples 12-14, wherein the first closure stage spans a first portion of the clamp arm range of motion up to a predetermined threshold.

Example 16

[0928] The surgical instrument of Example 15, wherein the second closure stage spans a second portion of the clamp arm range of motion beyond the predetermined threshold.

Example 17

[0929] The surgical instrument of Examples 15 or 16, wherein the control circuit is further configured to cause the transducer to switch from the first ultrasonic energy output to the second ultrasonic energy output in response to a transition of the clamp arm beyond the threshold.

Example 18

[0930] The surgical instrument of any one of Examples 12-17, wherein at least one of the first ultrasonic energy output and the second ultrasonic energy output is further determined by at least one situational parameter.

Example 19

[0931] The surgical instrument of Example 18, wherein the at least one situational parameter comprises type of the tissue.

Example 20

[0932] The surgical instrument of Examples 18 or 19, wherein the at least one situational parameter comprises anatomical location of the tissue.

Example 21

[0933] The surgical instrument of any one of Examples 18-20, wherein the at least one situational parameter comprises composition of the tissue.

[0934] While several forms have been illustrated and described, it is not the intention of the applicant to restrict or limit the scope of the appended claims to such detail. Numerous modifications, variations, changes, substitutions, combinations, and equivalents to those forms may be imple-

mented and will occur to those skilled in the art without departing from the scope of the present disclosure. Moreover, the structure of each element associated with the described forms can be alternatively described as a means for providing the function performed by the element. Also, where materials are disclosed for certain components, other materials may be used. It is therefore to be understood that the foregoing description and the appended claims are intended to cover all such modifications, combinations, and variations as falling within the scope of the disclosed forms. The appended claims are intended to cover all such modifications, variations, changes, substitutions, modifications, and equivalents.

[0935] The foregoing detailed description has set forth various forms of the devices and/or processes via the use of block diagrams, flowcharts, and/or examples. Insofar as such block diagrams, flowcharts, and/or examples contain one or more functions and/or operations, it will be understood by those within the art that each function and/or operation within such block diagrams, flowcharts, and/or examples can be implemented, individually and/or collectively, by a wide range of hardware, software, firmware, or virtually any combination thereof. Those skilled in the art will recognize that some aspects of the forms disclosed herein, in whole or in part, can be equivalently implemented in integrated circuits, as one or more computer programs running on one or more computers (e.g., as one or more programs running on one or more computer systems), as one or more programs running on one or more processors (e.g., as one or more programs running on one or more microprocessors), as firmware, or as virtually any combination thereof, and that designing the circuitry and/or writing the code for the software and or firmware would be well within the skill of one of skill in the art in light of this disclosure. In addition, those skilled in the art will appreciate that the mechanisms of the subject matter described herein are capable of being distributed as one or more program products in a variety of forms, and that an illustrative form of the subject matter described herein applies regardless of the particular type of signal bearing medium used to actually carry out the distribution.

[0936] Instructions used to program logic to perform various disclosed aspects can be stored within a memory in the system, such as dynamic random access memory (DRAM), cache, flash memory, or other storage. Furthermore, the instructions can be distributed via a network or by way of other computer readable media. Thus a machine-readable medium may include any mechanism for storing or transmitting information in a form readable by a machine (e.g., a computer), but is not limited to, floppy diskettes, optical disks, compact disc, read-only memory (CD-ROMs), and magneto-optical disks, read-only memory (ROMs), random access memory (RAM), erasable programmable read-only memory (EPROM), electrically erasable programmable read-only memory (EEPROM), magnetic or optical cards, flash memory, or a tangible, machine-readable storage used in the transmission of information over the Internet via electrical, optical, acoustical or other forms of propagated signals (e.g., carrier waves, infrared signals, digital signals, etc.). Accordingly, the non-transitory computer-readable medium includes any type of tangible machine-readable medium suitable for storing or transmitting electronic instructions or information in a form readable by a machine (e.g., a computer).

[0937] As used in any aspect herein, the term “control circuit” may refer to, for example, hardwired circuitry, programmable circuitry (e.g., a computer processor comprising one or more individual instruction processing cores, processing unit, processor, microcontroller, microcontroller unit, controller, digital signal processor (DSP), programmable logic device (PLD), programmable logic array (PLA), or field programmable gate array (FPGA)), state machine circuitry, firmware that stores instructions executed by programmable circuitry, and any combination thereof. The control circuit may, collectively or individually, be embodied as circuitry that forms part of a larger system, for example, an integrated circuit (IC), an application-specific integrated circuit (ASIC), a system on-chip (SoC), desktop computers, laptop computers, tablet computers, servers, smart phones, etc. Accordingly, as used herein, “control circuit” includes, but is not limited to, electrical circuitry having at least one discrete electrical circuit, electrical circuitry having at least one integrated circuit, electrical circuitry having at least one application specific integrated circuit, electrical circuitry forming a general purpose computing device configured by a computer program (e.g., a general purpose computer configured by a computer program which at least partially carries out processes and/or devices described herein, or a microprocessor configured by a computer program which at least partially carries out processes and/or devices described herein), electrical circuitry forming a memory device (e.g., forms of random access memory), and/or electrical circuitry forming a communications device (e.g., a modem, communications switch, or optical-electrical equipment). Those having skill in the art will recognize that the subject matter described herein may be implemented in an analog or digital fashion or some combination thereof.

[0938] As used in any aspect herein, the term “logic” may refer to an app, software, firmware and/or circuitry configured to perform any of the aforementioned operations. Software may be embodied as a software package, code, instructions, instruction sets and/or data recorded on non-transitory computer readable storage medium. Firmware may be embodied as code, instructions or instruction sets and/or data that are hard-coded (e.g., nonvolatile) in memory devices.

[0939] As used in any aspect herein, the terms “component,” “system,” “module” and the like can refer to a computer-related entity, either hardware, a combination of hardware and software, software, or software in execution.

[0940] As used in any aspect herein, an “algorithm” refers to a self-consistent sequence of steps leading to a desired result, where a “step” refers to a manipulation of physical quantities and/or logic states which may, though need not necessarily, take the form of electrical or magnetic signals capable of being stored, transferred, combined, compared, and otherwise manipulated. It is common usage to refer to these signals as bits, values, elements, symbols, characters, terms, numbers, or the like. These and similar terms may be associated with the appropriate physical quantities and are merely convenient labels applied to these quantities and/or states.

[0941] A network may include a packet switched network. The communication devices may be capable of communicating with each other using a selected packet switched network communications protocol. One example communications protocol may include an Ethernet communications

protocol which may be capable permitting communication using a Transmission Control Protocol/Internet Protocol (TCP/IP). The Ethernet protocol may comply or be compatible with the Ethernet standard published by the Institute of Electrical and Electronics Engineers (IEEE) titled "IEEE 802.3 Standard", published in December, 2008 and/or later versions of this standard. Alternatively or additionally, the communication devices may be capable of communicating with each other using an X.25 communications protocol. The X.25 communications protocol may comply or be compatible with a standard promulgated by the International Telecommunication Union-Telecommunication Standardization Sector (ITU-T). Alternatively or additionally, the communication devices may be capable of communicating with each other using a frame relay communications protocol. The frame relay communications protocol may comply or be compatible with a standard promulgated by Consultative Committee for International Telegraph and Telephone (CCITT) and/or the American National Standards Institute (ANSI). Alternatively or additionally, the transceivers may be capable of communicating with each other using an Asynchronous Transfer Mode (ATM) communications protocol. The ATM communications protocol may comply or be compatible with an ATM standard published by the ATM Forum titled "ATM-MPLS Network Interworking 2.0" published August 2001, and/or later versions of this standard. Of course, different and/or after-developed connection-oriented network communication protocols are equally contemplated herein.

[0942] Unless specifically stated otherwise as apparent from the foregoing disclosure, it is appreciated that, throughout the foregoing disclosure, discussions using terms such as "processing," "computing," "calculating," "determining," "displaying," or the like, refer to the action and processes of a computer system, or similar electronic computing device, that manipulates and transforms data represented as physical (electronic) quantities within the computer system's registers and memories into other data similarly represented as physical quantities within the computer system memories or registers or other such information storage, transmission or display devices.

[0943] One or more components may be referred to herein as "configured to," "configurable to," "operable/operative to," "adapted/adaptable," "able to," "conformable/conformed to," etc. Those skilled in the art will recognize that "configured to" can generally encompass active-state components and/or inactive-state components and/or standby-state components, unless context requires otherwise.

[0944] The terms "proximal" and "distal" are used herein with reference to a clinician manipulating the handle portion of the surgical instrument. The term "proximal" refers to the portion closest to the clinician and the term "distal" refers to the portion located away from the clinician. It will be further appreciated that, for convenience and clarity, spatial terms such as "vertical", "horizontal", "up", and "down" may be used herein with respect to the drawings. However, surgical instruments are used in many orientations and positions, and these terms are not intended to be limiting and/or absolute.

[0945] Those skilled in the art will recognize that, in general, terms used herein, and especially in the appended claims (e.g., bodies of the appended claims) are generally intended as "open" terms (e.g., the term "including" should be interpreted as "including but not limited to," the term "having" should be interpreted as "having at least," the term

"includes" should be interpreted as "includes but is not limited to," etc.). It will be further understood by those within the art that if a specific number of an introduced claim recitation is intended, such an intent will be explicitly recited in the claim, and in the absence of such recitation no such intent is present. For example, as an aid to understanding, the following appended claims may contain usage of the introductory phrases "at least one" and "one or more" to introduce claim recitations. However, the use of such phrases should not be construed to imply that the introduction of a claim recitation by the indefinite articles "a" or "an" limits any particular claim containing such introduced claim recitation to claims containing only one such recitation, even when the same claim includes the introductory phrases "one or more" or "at least one" and indefinite articles such as "a" or "an" (e.g., "a" and/or "an" should typically be interpreted to mean "at least one" or "one or more"); the same holds true for the use of definite articles used to introduce claim recitations.

[0946] In addition, even if a specific number of an introduced claim recitation is explicitly recited, those skilled in the art will recognize that such recitation should typically be interpreted to mean at least the recited number (e.g., the bare recitation of "two recitations," without other modifiers, typically means at least two recitations, or two or more recitations). Furthermore, in those instances where a convention analogous to "at least one of A, B, and C, etc." is used, in general such a construction is intended in the sense one having skill in the art would understand the convention (e.g., "a system having at least one of A, B, and C" would include but not be limited to systems that have A alone, B alone, C alone, A and B together, A and C together, B and C together, and/or A, B, and C together, etc.). In those instances where a convention analogous to "at least one of A, B, or C, etc." is used, in general such a construction is intended in the sense one having skill in the art would understand the convention (e.g., "a system having at least one of A, B, or C" would include but not be limited to systems that have A alone, B alone, C alone, A and B together, A and C together, B and C together, and/or A, B, and C together, etc.). It will be further understood by those within the art that typically a disjunctive word and/or phrase presenting two or more alternative terms, whether in the description, claims, or drawings, should be understood to contemplate the possibilities of including one of the terms, either of the terms, or both terms unless context dictates otherwise. For example, the phrase "A or B" will be typically understood to include the possibilities of "A" or "B" or "A and B."

[0947] With respect to the appended claims, those skilled in the art will appreciate that recited operations therein may generally be performed in any order. Also, although various operational flow diagrams are presented in a sequence(s), it should be understood that the various operations may be performed in other orders than those which are illustrated, or may be performed concurrently. Examples of such alternate orderings may include overlapping, interleaved, interrupted, reordered, incremental, preparatory, supplemental, simultaneous, reverse, or other variant orderings, unless context dictates otherwise. Furthermore, terms like "responsive to," "related to," or other past-tense adjectives are generally not intended to exclude such variants, unless context dictates otherwise.

[0948] It is worthy to note that any reference to “one aspect,” “an aspect,” “an exemplification,” “one exemplification,” and the like means that a particular feature, structure, or characteristic described in connection with the aspect is included in at least one aspect. Thus, appearances of the phrases “in one aspect,” “in an aspect,” “in an exemplification,” and “in one exemplification” in various places throughout the specification are not necessarily all referring to the same aspect. Furthermore, the particular features, structures or characteristics may be combined in any suitable manner in one or more aspects.

[0949] Any patent application, patent, non-patent publication, or other disclosure material referred to in this specification and/or listed in any Application Data Sheet is incorporated by reference herein, to the extent that the incorporated materials is not inconsistent herewith. As such, and to the extent necessary, the disclosure as explicitly set forth herein supersedes any conflicting material incorporated herein by reference. Any material, or portion thereof, that is said to be incorporated by reference herein, but which conflicts with existing definitions, statements, or other disclosure material set forth herein will only be incorporated to the extent that no conflict arises between that incorporated material and the existing disclosure material.

[0950] In summary, numerous benefits have been described which result from employing the concepts described herein. The foregoing description of the one or more forms has been presented for purposes of illustration and description. It is not intended to be exhaustive or limiting to the precise form disclosed. Modifications or variations are possible in light of the above teachings. The one or more forms were chosen and described in order to illustrate principles and practical application to thereby enable one of ordinary skill in the art to utilize the various forms and with various modifications as are suited to the particular use contemplated. It is intended that the claims submitted herewith define the overall scope.

1. A surgical instrument, comprising:
 - an end effector, comprising:
 - an ultrasonic blade; and
 - a clamp arm movable relative to the ultrasonic blade to transition the end effector through different closure stages between an open configuration and a closed configuration to clamp tissue between the ultrasonic blade and the clamp arm;
 - a transducer configured to generate an ultrasonic energy output;
 - a waveguide configured to transmit the ultrasonic energy output to the ultrasonic blade;
 - a sensor configured to transmit sensor signals indicative of the closure stages of the end effector; and
 - a control circuit configured to:
 - receive the sensor signals; and
 - select an operational mode from operational modes delivering different ultrasonic energy outputs from the transducer based on the received sensor signals.
2. The surgical instrument of claim 1, wherein the operational modes comprise:
 - a low energy operational mode configured to cause tissue separation but not tissue coagulation; and
 - a high energy operational mode configured to cause the tissue coagulation.

3. The surgical instrument of claim 1, wherein the closure stages comprise an initial closure stage spanning an initial portion of the clamp arm range of motion up to a predetermined threshold.

4. The surgical instrument of claim 3, wherein the control circuit is configured to select a first operational mode delivering a first ultrasonic energy output in the initial closure stage.

5. The surgical instrument of claim 4, wherein the control circuit is configured to switch to a second operational mode delivering a second ultrasonic energy output greater than the first ultrasonic energy output beyond the predetermined threshold.

6. The surgical instrument of claim 1, wherein the selection between operational modes is further based on at least one situational parameter.

7. The surgical instrument of claim 6, wherein the at least one situational parameter comprises type of the tissue.

8. The surgical instrument of claim 6, wherein the at least one situational parameter comprises anatomical location of the tissue.

9. The surgical instrument of claim 6, wherein the at least one situational parameter comprises composition of the tissue.

10. The surgical instrument of claim 1, wherein each of the closure stages is defined by a range of angular distances between the clamp arm and the ultrasonic blade.

11. The surgical instrument of claim 1, further comprising a drive member configured to motivate the clamp member to move through the closure stages, and wherein each of closure stages is defined by a range of positions of the drive member.

12. A surgical instrument, comprising:

an end effector, comprising:

an ultrasonic blade; and

a clamp arm movable relative to the ultrasonic blade to transition the end effector through different closure stages between an open configuration and a closed configuration to clamp tissue between the ultrasonic blade and the clamp arm, wherein the closure stages comprise:

a first closure stage; and

a second closure stage after the first closure stage;

a transducer configured to generate an ultrasonic energy output;

a waveguide configured to transmit the ultrasonic energy output to the ultrasonic blade;

a sensor circuit configured to transmit a sensor signal indicative of detecting an initial contact of the clamp arm with the tissue; and

a control circuit configured to:

receive the sensor signal;

cause the transducer to generate a first ultrasonic energy output in response to receiving the sensor signal in the first closure stage; and

cause the transducer to generate a second ultrasonic energy output greater than the first ultrasonic output in response to receiving the sensor signal in the second closure stage.

13. The surgical instrument of claim 12, wherein the control circuit is further configured to cause the transducer to switch from the first ultrasonic energy output to the second ultrasonic energy output in response to a transition from the first closure stage to the second closure stage.

14. The surgical instrument of claim 12, wherein the first ultrasonic energy output is configured to cause tissue separation but not tissue coagulation, and wherein the second ultrasonic energy output is configured to cause the tissue coagulation.

15. The surgical instrument of claim 12, wherein the first closure stage spans a first portion of the clamp arm range of motion up to a predetermined threshold.

16. The surgical instrument of claim 15, wherein the second closure stage spans a second portion of the clamp arm range of motion beyond the predetermined threshold.

17. The surgical instrument of claim 15, wherein the control circuit is further configured to cause the transducer to switch from the first ultrasonic energy output to the second ultrasonic energy output in response to a transition of the clamp arm beyond the predetermined threshold.

18. The surgical instrument of claim 12, wherein at least one of the first ultrasonic energy output and the second ultrasonic energy output is further determined by at least one situational parameter.

19. The surgical instrument of claim 18, wherein the at least one situational parameter comprises type of the tissue.

20. The surgical instrument of claim 18, wherein the at least one situational parameter comprises anatomical location of the tissue.

21. The surgical instrument of claim 18, wherein the at least one situational parameter comprises composition of the tissue.

* * * * *