

12

EUROPEAN PATENT APPLICATION

21 Application number: **88203014.1**

51 Int. Cl.⁵: **H01R 23/68**

22 Date of filing: **23.12.88**

43 Date of publication of application:
27.06.90 Bulletin 90/26

84 Designated Contracting States:
AT BE CH DE ES FR GB GR IT LI LU NL SE

71 Applicant: **BURNDY ELECTRA N.V.**
Antoon Spinostraat 8
B-2800 Mechelen(BE)

72 Inventor: **Bueds, Marc Filemon**
Vlasstraat 8
B-2860 Sint-Katelijne-Waver(BE)
Inventor: **Morlion, Danny Louis Cornelis**
Coupure 368
B-9000 Gent(BE)

74 Representative: **de Vries, Johannes Hendrik**
Fokke et al
Octrooibureau Los en Stigter B.V. P.O. Box
20052
NL-1000 HB Amsterdam(NL)

54 **Connector assembly for printed circuit boards.**

57 A connector for printed circuit boards comprises first and second connector elements. The first connector element has a first housing of insulating material including a base and two spaced upright sidewalls extending parallel to each other from the base and defining a contact region therebetween and a plurality of rows of male contacts provided within said contact region parallel to the sidewalls. The second connector element has a second housing of insulating material including outwardly directed sidewalls adapted to be fitted between the spaced sidewalls of the first housing, and a plurality of parallel rows of female contacts having contact portions for contacting the male contacts when the second housing is received between the sidewalls of the first housing.

A plurality of first additional contacts are provided in the first housing, which first additional contacts are male contacts mounted in the base of the first housing in at least one row close to one of the sidewalls.

A plurality of second additional contacts are arranged in at least one row in the second housing adjacent a corresponding one of its outwardly di-

rected sidewalls which is provided with a plurality of slots for receiving the at least one row of first additional contacts, the second additional contacts having contact portions for contacting the first additional contacts.

In the alternative, the first additional contacts are male contacts mounted in a row in the base of the first housing. The second housing comprises two parts each having outwardly directed sidewalls, one sidewall of one part facing one sidewall of the other part, wherein the printed circuit board to be connected to the contacts of the second housing is to be located above the facing sidewalls, the facing sidewalls of said two parts being provided with slots for receiving the row of first additional contacts and at least one of the parts being provided with second additional contacts arranged in a row adjacent the sidewall provided with slots.

EP 0 374 307 A1

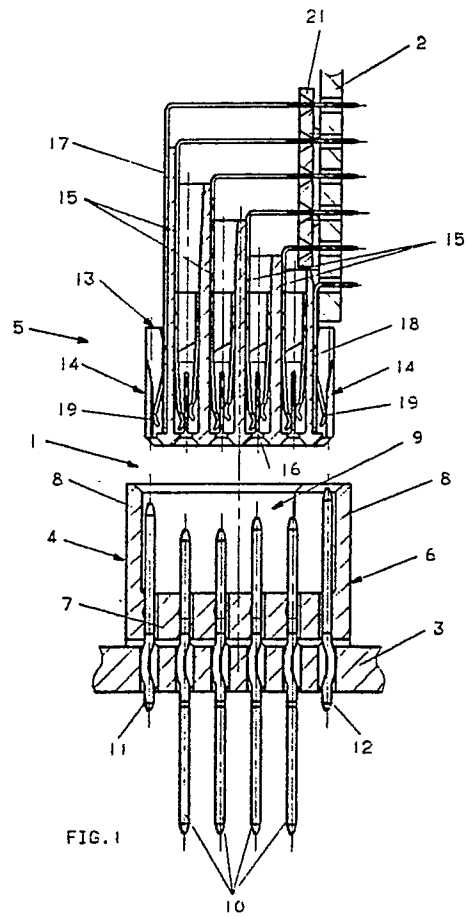

Connector assembly for printed circuit boards

The invention relates to a connector assembly for printed circuit boards according to the preamble of claim 1 or 9.

A connector assembly of this type, also known as a so-called backplane connector, is described in US patent 4,655,518. In this known connector assembly, the first additional contacts are mounted in a sidewall of the first housing and made as a spring type contact. The second additional contacts are mounted on one of the outwardly directed sidewalls of the second housing. Therefore, both the first and second additional contacts have to be especially manufactured contacts and have to be fixed in the first and second housing, respectively, in a special manner. These additional contacts are mounted in this special manner to provide current distribution contacts without increasing the dimensions of the connector assembly.

It is an object of the invention to provide an improved connector assembly of the above-mentioned type, wherein standard contacts can be used at least partially for the additional contacts which standard contacts can be simply mounted in the corresponding housing.

To this end, according to a first aspect of the invention the connector assembly is characterized by the features of the characterising part of claim 1.

In this manner the first additional contacts can be standard male contacts resulting in the possibility to assemble the first connector element by means of a selective pin insertion machine which inserts all male contacts including the additional contacts at desired locations in the printed circuit board, whereafter the first housing is pushed with its base on the contacts. In this case two or more contacts may be connected in parallel on the printed circuit board. Of course it is also possible that the pin insertion machine inserts the male contacts only whereas the additional contacts are inserted manually after mounting the first housing. Two or more additional contacts can be integral in this case. Further two or more integral additional contacts can be provided with a common power connection end opposite of the contact region of the first housing.

As an alternative the first connector element may be preassembled, so that the contacts are inserted in holes of the printed circuit board simultaneously. The additional contacts may also be preassembled or may be manually inserted when the connector element is mounted on the printed circuit board.

As the first additional contacts are received in the slots of the second housing, the overall dimen-

sion of the connector assembly is not increased substantially.

Moreover, if due to circumstances one or more of the first additional contacts are damaged, they can be removed easily and replaced by new contacts.

According to a favourable embodiment of the invention said first additional contacts extend along a longer distance from said base into said contact region than said male contacts. In this manner different contact levels can be provided for the contacts so that for example first make/last break facilities for ground and power connections can be provided in a very convenient manner.

According to a further favourable embodiment of the invention said male contacts and said first additional contacts are lengthened at the side opposite of the contact region of the first housing, a third housing of insulating material being provided including a base and two spaced upright sidewalls extending parallel to each other from said base and defining a second contact region therebetween, said lengthened male and first additional contacts projecting through said base into said second contact region thus providing a third connector element with at least one row of additional contacts close to one of its sidewalls.

Thereby high density connections can be provided with a backplane between the first and third connector elements.

According to the invention the third connector element may cooperate with a fourth connector element with a fourth housing of insulating material including outwardly directed sidewalls adapted to be fitted between said spaced sidewalls of said third housing, and a plurality of parallel rows of fourth contacts and at least one row of fourth additional contacts, said fourth and fourth additional contacts each having contact portions for contacting the lengthened male and first additional contacts, respectively, when said fourth housing is received between the sidewalls of said third housing, at least one of the outwardly directed sidewalls of said fourth housing being provided with a plurality of slots for receiving said at least one row of lengthened first additional contacts.

Preferably the second and fourth connector elements are identical to each other.

In an alternative embodiment said fourth connector element is made as a cable connector element for a shielded cable with a plurality of wires connected to said fourth with a metal cap with a passage for said cable adapted to contact the shield of the cable, wherein said at least one row of fourth additional contacts is connected to said met-

al cap thereby providing a continuous connection from said shield to said first additional contacts.

According to a second aspect based upon the general inventive concept of the invention, said first additional contacts are male contacts mounted in a row in the base of said first housing and said second housing comprises two parts each having outwardly directed sidewalls, one sidewall of one part facing one sidewall of the other part, wherein the printed circuit board to be connected to the contacts of the second housing is to be located above the facing sidewalls, the facing sidewalls of said two parts being provided with slots for receiving said row of first additional contacts, at least one of said parts being provided with said second additional contacts arranged in a row adjacent said sidewall provided with slots.

This embodiment of the invention may be preferred in high speed applications, as the printed circuit board connected to the contacts of the second housing is located more centrally with respect to the contacts of the second housing, whereby the length of the contacts, in particular the contacts at the outsides of the second housing, can be shorter.

Preferably, said parts of said second housing are identical and said row of first additional contacts is mounted in the center of the base of the first housing.

The invention will be further explained by reference to the drawings in which a plurality of embodiments of the connector assembly according to the invention are shown.

Fig. 1 schematically shows a cross section of a first embodiment of the connector assembly according to the invention for connecting a daughter printed circuit board to a backplane.

Fig. 2 is a partially shown perspective view of the second connector element of the connector assembly according to fig. 1.

Fig. 3 shows a cross section of the first connector element of a second embodiment of the connector assembly according to the invention.

Fig. 4 is a perspective view of three integral additional contacts of the first connector element of fig. 3.

Fig. 5 shows a third embodiment of the connector assembly according to the invention providing connector elements on both sides of the backplane.

Fig. 6 shows a cross section of a fourth embodiment of the connector assembly according to the invention.

Fig. 7 schematically shows a cross section of the second connector element of a fifth embodiment before mounting.

Fig. 8 shows the second connector element of fig. 7 after mounting together with a first connector element.

tor element.

Fig. 9 shows a sixth embodiment of the connector assembly according to the invention.

Referring to fig. 1, there is shown a connector assembly 1 for connecting a printed circuit board 2 (daughter board) to a printed circuit board 3 (backplane). The connector assembly 1 comprises a first connector element 4 connected to the backplane 3 and a second connector element 5 connected to the daughter board 2.

The first connector element 4 comprises a first housing 6 of insulating material including a base 7 and two spaced upright sidewalls 8 which extend parallel to each other from the base 7. A contact region 9 is defined between sidewalls 8. Further the first connector element 4 is provided with four rows of male signal contacts 10 which are press fit in the backplane 3 and extend through the base 7 into the contact region 9.

The first connector element 4 is further provided with two rows of first additional contacts 11 and 12 which rows of additional contacts 11, 12 are close to a corresponding sidewall 8. As appears from fig. 1 the additional contacts 11, 12 are male contacts which are also press fit in the backplane 3 and extend through the base 7 into the contact region 9 of the housing 6 along a longer distance from the base 7 than the signal connector 10. Thereby different contact levels for the additional contacts 11, 12 with respect to each other and with respect to the signal contacts 10 are possible, which results in first make/last break facilities for these additional contacts 11, 12 which are used for ground and power connection. Moreover, when due to circumstances one or more of the additional contacts 11, 12 are damaged, they can easily be removed and replaced by new contacts.

A further major advantage of the first connector element 4 is that this connector element can be assembled by a selective pin insertion machine which inserts the signal contacts 10 and additional contacts 11, 12 at the desired locations of the backplane 3 whereafter the housing 6 is pushed with its base 7 on the contacts 10-12. As mentioned above, the additional contacts 11, 12 can be manually inserted, especially when two or more additional contacts 11, 12 are integral. It is further possible to provide a pre-assembled connector element 4 which is mounted on the backplane 3 by simultaneously inserting all contacts. In this case the additional contacts 11, 12 can also be manually inserted afterwards.

It is noted that the cross section of the additional contacts 11, 12 may have any desired size and does not have to be equal to the cross section of the male contacts 10.

The second connector element 5 is provided with a second housing 13 of insulating material

including outwardly directed sidewalls 14 adapted to be fitted between the sidewalls 8 of the first housing 6. The second connector element 5 includes four rows of female signal contacts 15 having forked contact portions at their lower ends for contacting the male signal contacts 10 when the second housing 13 is inserted into the first housing 6. The forked contact portions of the female contacts 15 lie within cavities 16 of the second housing 13.

The second connector element 2 is further provided with two rows of second additional contacts 17 and 18 for ground and power connection. The rows of additional contacts 17 and 18 are located adjacent a corresponding sidewall 14 of the second housing 13. At their lower ends the additional contacts 17, 18 are provided with a spring type tongue 19 as contact portions for contacting the male additional contacts 11, 12. The tongues 19 are biased against the sidewalls 14. These sidewalls 14 are further provided with slots 20 as more clearly shown in the perspective view of fig. 2. These slots 20 are provided for receiving the additional contacts 11, 12.

Due to the described design of the connector assembly 1, the overall dimension of the connector assembly is not increased substantially by the provision of the rows of additional contacts.

As shown in fig. 1 and 2 the contacts 15, 17 are guided through a guide plate 21 for aligning the outer ends of these contacts with the holes of the daughter board 2 in which the outer ends of all contacts 15, 17 and 19 are for example press fit.

In the embodiment of fig. 1 and 2 each three subsequent additional contacts 17 and 18 are integral as shown in fig. 2.

Fig. 3 shows a second embodiment of a first connector element 22 which mainly corresponds with the first connector element 4 of fig. 1. In this case three additional contacts 23 are also integral and provided with a common power connection end 24 as clearly shown in the perspective view of fig. 4. For the remaining part the connector element 22 is identical to the connector element 4 and will not further be described. It will be clear that any desired design for power connection to the additional contacts can be chosen. The advantage of the use of standard male contacts as additional contacts lies in the fact that in this case they can easily be inserted from the backside of the backplane 3.

The described design of the first connector element 4 provides the possibility to lengthen the first signal contacts 10 and the additional contacts 11, 12 at the side opposite of the contact region 9 of the first housing 6 as shown in fig. 5. Thereby a third connector element 25 can be provided with the backplane 3 lying in the center between the

connector elements 4 and 25. The third connector element 25 comprises a third housing 26 of insulating material with a base 27 and spaced upright sidewalls 28 extending parallel to each other from the base 27. Between the sidewalls 28 a contact region 29 is defined in which the lengthened contacts 8, 11 and 12 are projecting through the base 27. In this manner a high density connection is obtained with the backplane 3 as central part of the system. As shown in the embodiment of fig. 5 the third connector element 25 may cooperate with a fourth connector element 30 which is connected to another daughter board 31 and which is identical to the second connector element 5.

Referring to fig. 6 there is shown an alternative embodiment of the connector assembly with the first connector element 4 and third connector element 25 on both sides of the backplane 3. In this case the connector element 25 cooperates with a cable connector element 32 for a shielded cable 33. The cable connector element 32 is provided with a metal cap 34 for the cable 33 with a passage for this cable, which passage contacts the shield 35 of the cable 33 as indicated in fig. 6. Wires 36 of the cable 33 are connected to the signal contacts 37 mounted in a housing 38 of insulating material. The housing 38 mainly corresponds with the housing 13 of the second connector element 5. In this case the additional contacts 17, 18 are contacting the metal cap 34 so that a continuous low impedance ground connection from the cable shield 35 to the daughter board 2 is obtained through the additional contacts 11, 12 of the connector elements 25 and 4 and the additional contacts 17, 18 of the connector element 5.

For high speed applications it may be desired to use contacts as short as possible. In the embodiments of fig. 1-5 in which the connector elements 5, 30 connected to the daughter board are located on one side of the daughter board the length of the contacts at the side directed away from the daughter board 2 is relatively long. Fig. 7 and 8 show a first embodiment of the invention in which the length of the contacts is decreased.

As shown in fig. 7 and 8 a connector element 39 is provided with a housing 40 of insulating material having two equal parts 41 each having outwardly directed sidewalls 42 and 43. The sidewalls 43 of the parts 41 are facing each other and each are provided with slots 44 corresponding with the slots 20 in the sidewall 14 of the housing 13.

In the mounted situation of fig. 8 the housing 40 includes four rows of signal contacts 45 with forked contact portions for contacting the male signal contacts 46 of a connector element 47 with a housing 48 of insulating material. The construction of the housing 48 corresponds the center of the

housing 48, which additional contacts 49 with the construction of the housing 6. However, in this embodiment one row of additional contacts 49 is provided in cooperate with additional contacts 50 of the connector element 39. Each part 41 of the housing 40 is provided with one row of additional contacts 50 mounted in the same manner as the additional contacts 17, 18 in the housing 13 of the connector element 5. The additional contacts 49 will be received in the slots 44 in the sidewalls 43 of the parts 41 while contacting tongues 51 of the additional contacts 50.

A daughter board 52 is located in the center of the housing 40 in line with the additional contacts 49 and 50 so that these additional contacts can be provided without increasing the overall dimension of the housing 40. The outer ends 53 of all contacts 45 and 50 are surface mounted on the daughter board 52.

As shown in fig. 9, the outer ends of the contacts 45 and 50 of the connector element 39 can also be mounted in plated through holes in the daughter board 52 in any desired manner, for example by press fit.

Although not specifically claimed the embodiments of fig. 7, 8 and 9 can be modified in the same manner as described for the connector assembly 1 of fig. 1.

It will be clear that the invention is not limited in any way to the embodiments described and shown in the drawings and can be varied in a number of ways within the scope of the claims.

Claims

1. Connector assembly for printed circuit boards, comprising
 a first connector element with a first housing of insulating material including a base and two spaced upright sidewalls extending parallel to each other from said base and defining a contact region therebetween and a plurality of rows of male contacts provided within said contact region parallel to said sidewalls,
 a second connector element with a second housing of insulating material including outwardly directed sidewalls adapted to be fitted between the spaced sidewalls of said first housing, and a plurality of parallel rows of female contacts having contact portions for contacting the male contacts when said second housing is received between the sidewalls of said first housing,
 a plurality of first additional contacts in said first housing, and
 a plurality of second additional contacts in said second housing, said second additional contacts having contact portions for contacting said first ad-

ditional contacts when said second housing is received between the sidewalls of said first housing, **characterized** in that

said first additional contacts are male contacts mounted in the base of said first housing in at least one row close to one of said sidewalls, and said second additional contacts being arranged in at least one row in said second housing adjacent a corresponding one of its outwardly directed sidewalls which is provided with a plurality of slots for receiving said at least one row of first additional contacts.

2. Connector assembly according to claim 1, **characterized** in that said first additional contacts extend along a longer distance from said base into said contact region than said male contacts.

3. Connector assembly according to claim 1 or 2, **characterized** in that said male contacts and said first additional contacts are lengthened at one side opposite of the contact region of the first housing, a third housing of insulating material being provided including a base and two spaced upright sidewalls extending parallel to each other from said base and defining a second contact region therebetween, said lengthened male and first additional contacts projecting through said base into said second contact region thus providing a third connector element with at least one row of additional contacts close to one of its sidewalls.

4. Connector assembly according to claim 3, **characterized** by a fourth connector element with a fourth housing of insulating material including outwardly directed sidewalls adapted to be fitted between said spaced sidewalls of said third housing, and a plurality of parallel rows of fourth contacts and at least one row of fourth additional contacts, said fourth and fourth additional contacts each having contact portions for contacting the lengthened male and first additional contacts, respectively, when said fourth housing is received between the sidewalls of said third housing, at least one of the outwardly directed sidewalls of said fourth housing being provided with a plurality of slots for receiving said at least one row of lengthened first additional contacts.

5. Connector assembly according to claim 4, **characterized** in that the second and fourth connector elements are identical to each other.

6. Connector assembly according to claim 4, **characterized** in that said fourth connector element is made as a cable connector element for a shielded cable with a plurality of wires connected to said fourth contacts, said fourth connector element being provided with a metal cap with a passage for said cable adapted to contact the shield of the cable, wherein said at least one row of fourth additional contacts is connected to said metal cap thereby providing a continuous connection from

said shield to said first additional contacts.

7. Connector assembly according to claim 1 or 2, **characterized** in that a plurality of said first additional contacts are integral with each other.

8. Connector assembly according to claim 7, characterised in that a plurality of integral additional contacts are provided with a common power connection end opposite of the contact region of the first housing.

9. Connector assembly for printed circuit boards comprising

a first connector element with a first housing of insulating material including a base and two spaced upright sidewalls extending parallel to each other from said base and defining a contact region therebetween and a plurality of rows of male contacts provided within said contact region parallel to said sidewalls,

a second connector element with a second housing of insulating material including outwardly directed sidewalls adapted to be fitted between the spaced sidewalls of said first housing, and a plurality of parallel rows of female contacts having contact portions for contacting the male contacts when said second housing is received between the sidewalls of said first housing,

a plurality of first additional contacts in said first housing, and

a plurality of second additional contacts in said second housing, said second additional contacts having contact portions for contacting said first additional contacts when said second housing is received between the sidewalls of said first housing,

characterized in that

said first additional contacts are male contacts mounted in a row in the base of said first housing and

said second housing comprises two parts each having outwardly directed sidewalls, one sidewall of one part facing one sidewall of the other part, wherein the printed circuit board to be connected to the contacts of the second housing is to be located above the facing sidewalls, the facing sidewalls of said two parts being provided with slots for receiving said row of first additional contacts, at least one of said parts being provided with said second additional contacts arranged in a row adjacent said sidewall provided with slots.

10. Connector assembly according to claim 9, **characterized** in that said parts of said second housing are identical and said row of first additional contacts is mounted in the center of the base of the first housing.

5

10

15

20

25

30

35

40

45

50

55

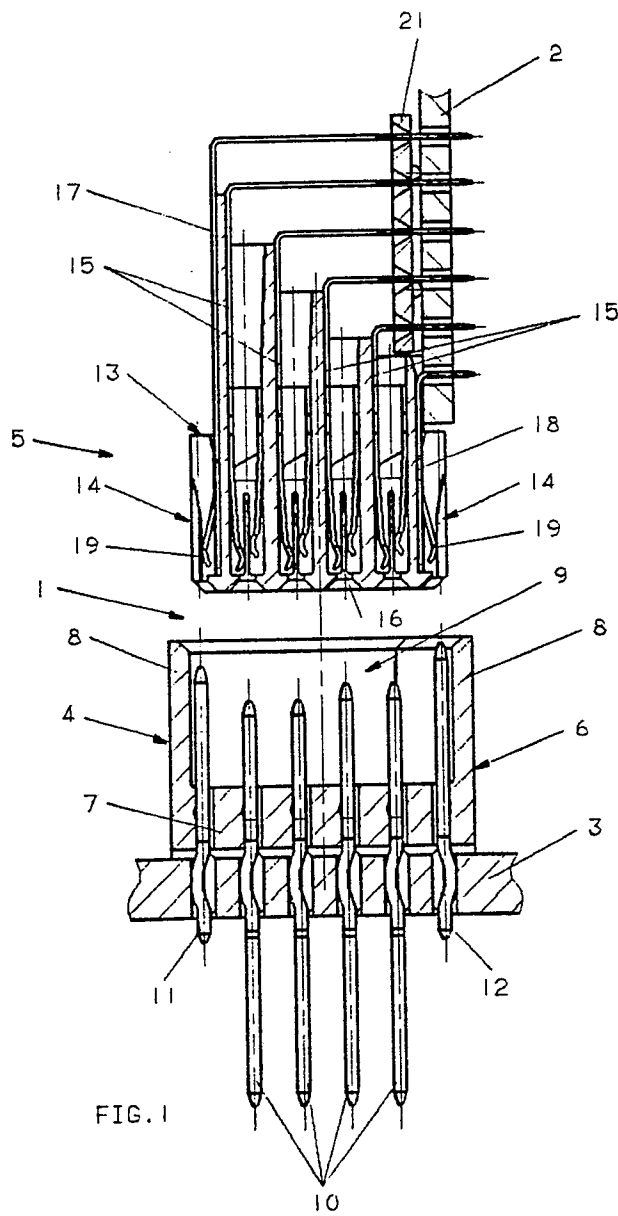

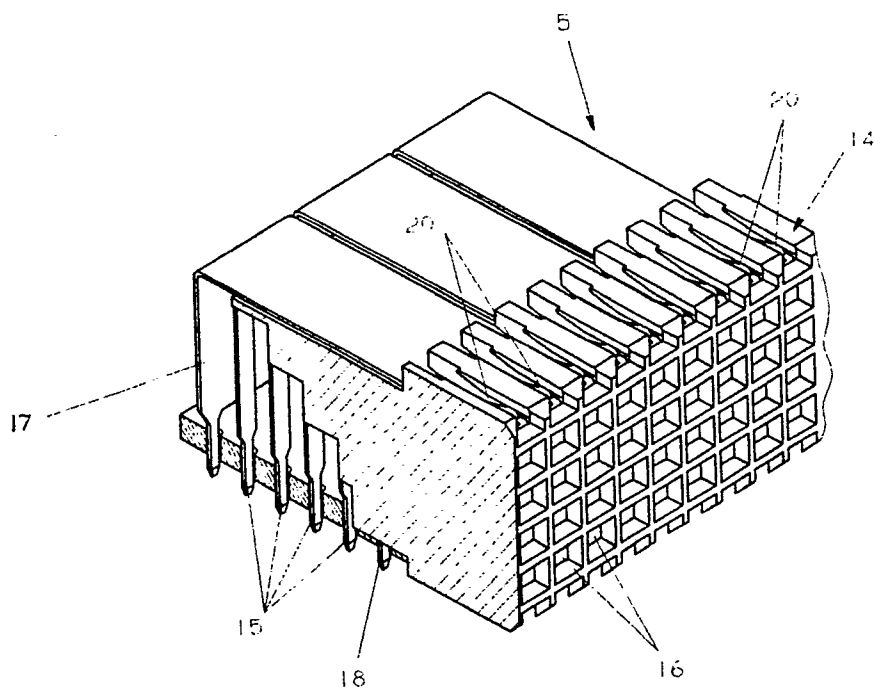
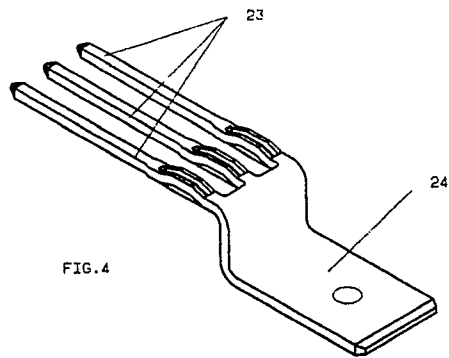
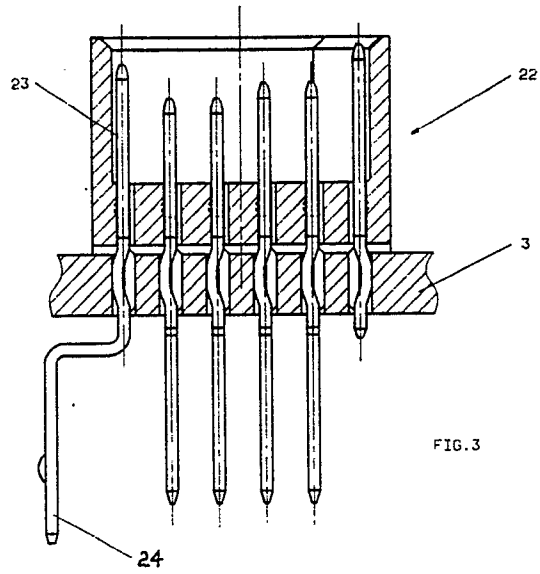

FIG. 2



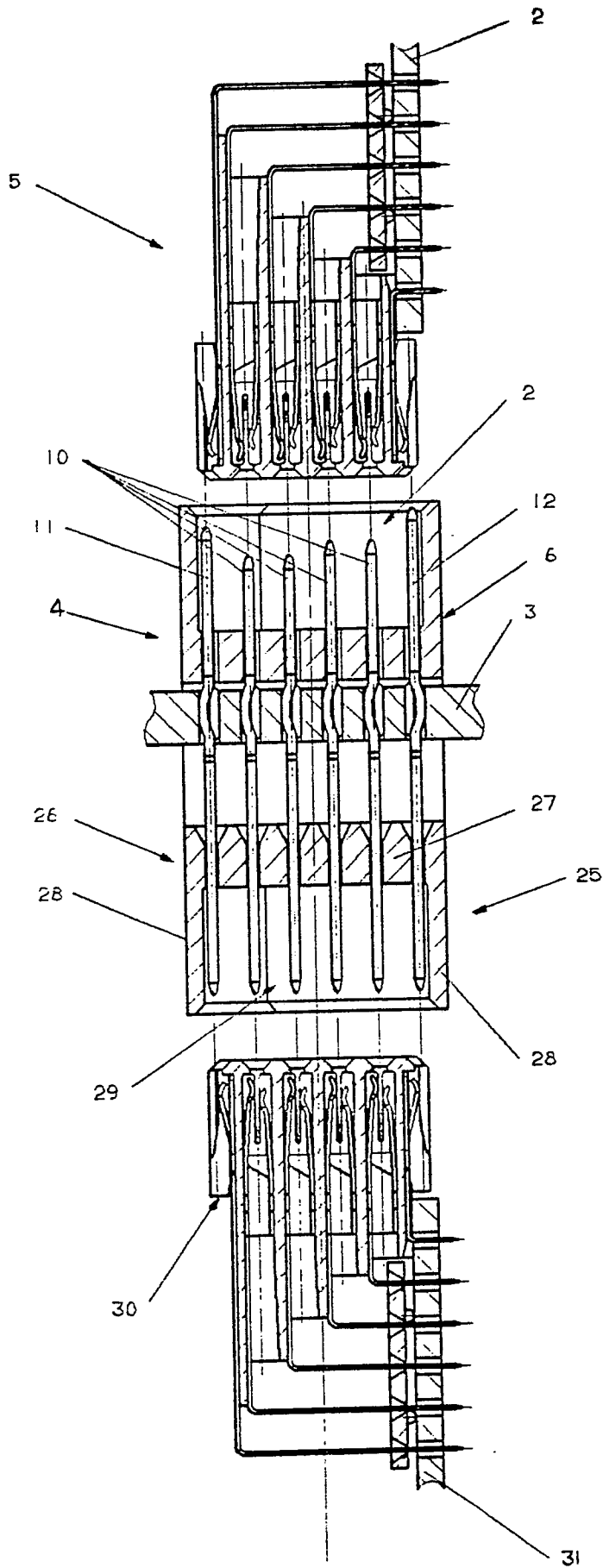

FIG. 5

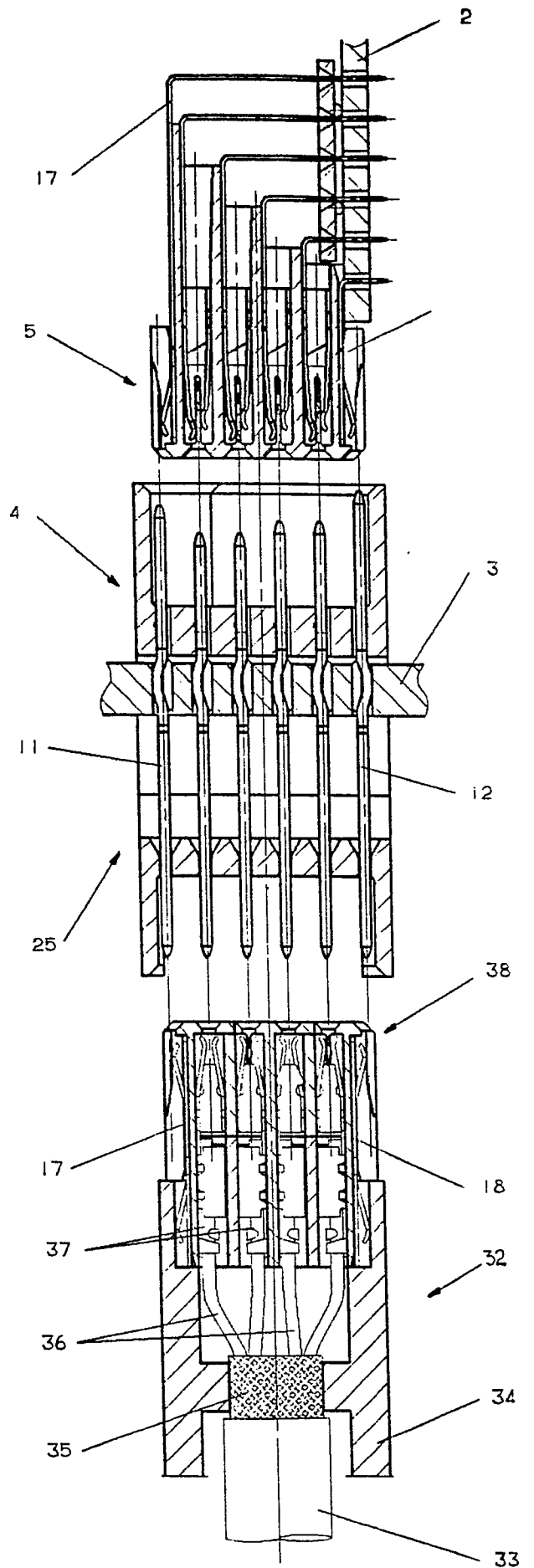

FIG. 6

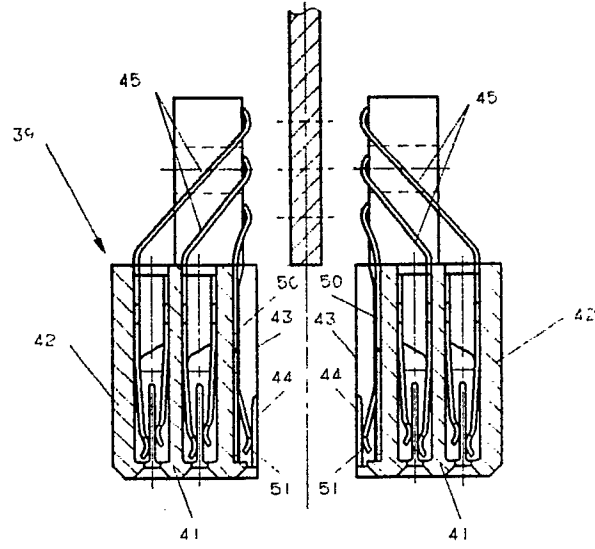

FIG. 7

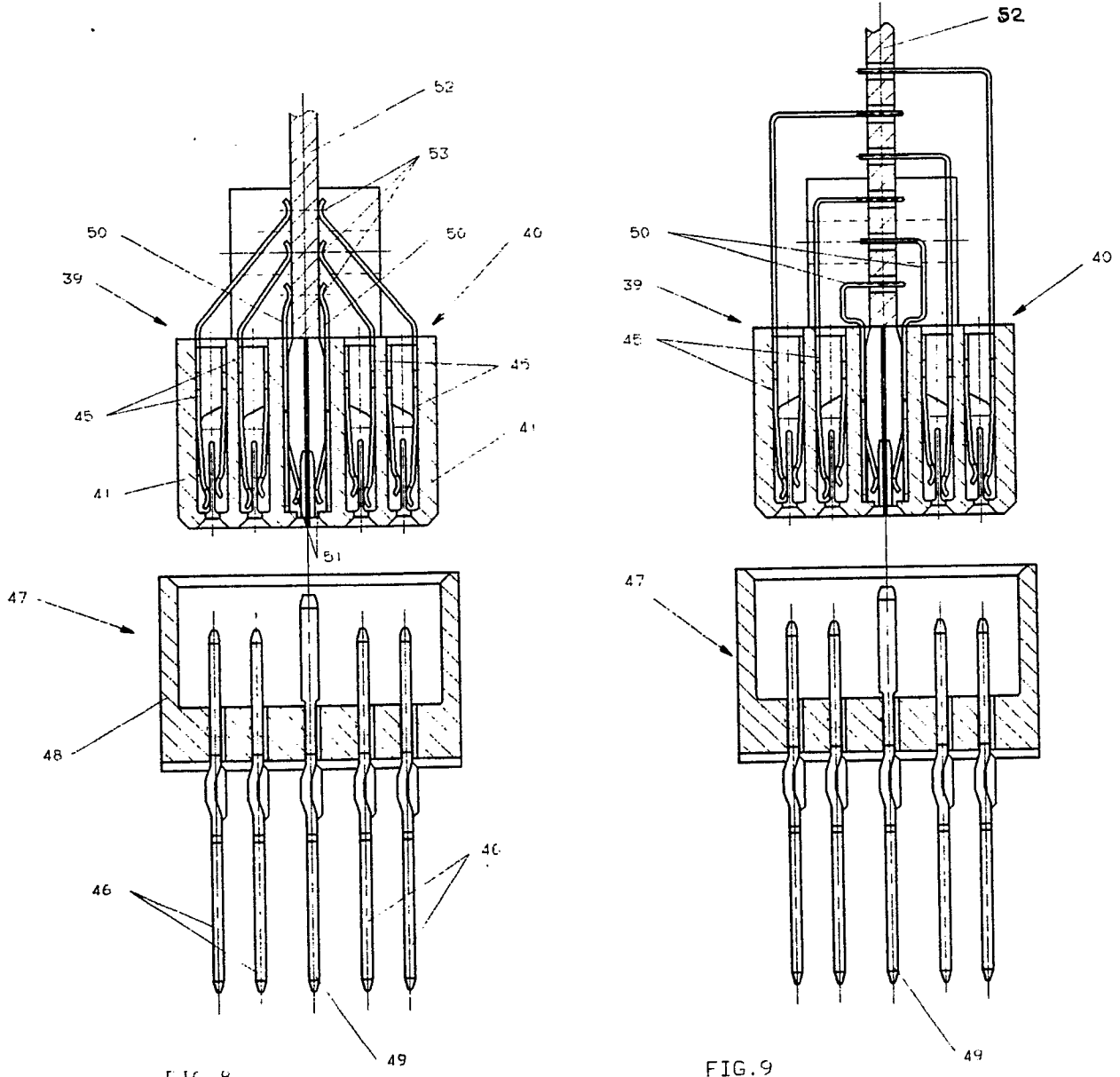

FIG. 8

FIG. 9



DOCUMENTS CONSIDERED TO BE RELEVANT			
Category	Citation of document with indication, where appropriate, of relevant passages	Relevant to claim	CLASSIFICATION OF THE APPLICATION (Int. Cl.5)
A	GB-A-2185160 (TERADYNE) * page 1, line 68 - line 110; figure 1 * ---	1-5	H01R23/68
A	EP-A-0292144 (HIROSE) * column 3, line 26 - line 36; figures 1, 2 * ---	6	
A	US-A-4631637 (BURROUGHS CORPORATION) * column 4, line 1 - line 19; figures 4, 5 * -----	9	
The present search report has been drawn up for all claims			TECHNICAL FIELDS SEARCHED (Int. Cl.5)
			H01R
Place of search THE HAGUE		Date of completion of the search 14 AUGUST 1989	Examiner CERIBELLA G.
CATEGORY OF CITED DOCUMENTS X : particularly relevant if taken alone Y : particularly relevant if combined with another document of the same category A : technological background O : non-written disclosure P : intermediate document		T : theory or principle underlying the invention E : earlier patent document, but published on, or after the filing date D : document cited in the application L : document cited for other reasons & : member of the same patent family, corresponding document	