



(51) International Patent Classification:
A61F 5/01 (2006.01)

(21) International Application Number:
PCT/US2014/012860

(22) International Filing Date:
24 January 2014 (24.01.2014)

(25) Filing Language: English

(26) Publication Language: English

(30) Priority Data:
61/756,438 24 January 2013 (24.01.2013) US
61/756,220 24 January 2013 (24.01.2013) US
61/894,953 24 October 2013 (24.10.2013) US

(71) Applicants: OSSUR HF [IS/IS]; Grjothals 5, IS-110 Reykjavik (IS). OSSUR AMERICAS, INC. [US/US]; 27051 Towne Centre Drive, Foothill Ranch, California 92610 (US).

(72) Inventors: INGIMUNDARSON, Arni Thor; Breidas 11, IS-210 Gardabaer (IS). INGVARSSON, Thorvaldur; Al-

fabyggd 14, IS-600 Akureyri (IS). BAKKEN, Nina; Lindebergasen 19B, N-1071 Oslo (NO). PETURSSON, Valgeir; Jorfagrund 8, IS-116 Reykjavik (IS). PALSDOT-TIR, Helga Run; Karfavogi 20, IS-104 Reykjavik (IS). STEFANSSON, Thorleifur; c/o Ossur hf, Grjothals 5, IS-110 Reykjavik (IS).

(74) Agent: CASSELL, Justin J.; Workman Nydegger, 60 East South Temple, Suite 1000, Salt Lake City, Utah 84111 (US).

(81) Designated States (unless otherwise indicated, for every kind of national protection available): AE, AG, AL, AM, AO, AT, AU, AZ, BA, BB, BG, BH, BN, BR, BW, BY, BZ, CA, CH, CL, CN, CO, CR, CU, CZ, DE, DK, DM, DO, DZ, EC, EE, EG, ES, FI, GB, GD, GE, GH, GM, GT, HN, HR, HU, ID, IL, IN, IR, IS, JP, KE, KG, KN, KP, KR, KZ, LA, LC, LK, LR, LS, LT, LU, LY, MA, MD, ME, MG, MK, MN, MW, MX, MY, MZ, NA, NG, NI, NO, NZ, OM, PA, PE, PG, PH, PL, PT, QA, RO, RS, RU, RW, SA, SC, SD, SE, SG, SK, SL, SM, ST, SV, SY, TH, TJ, TM, TN, TR, TT, TZ, UA, UG, US, UZ, VC, VN, ZA, ZM, ZW.

[Continued on next page]

(54) Title: ORTHOPEDIC DEVICE FOR TREATING COMPLICATIONS OF THE HIP

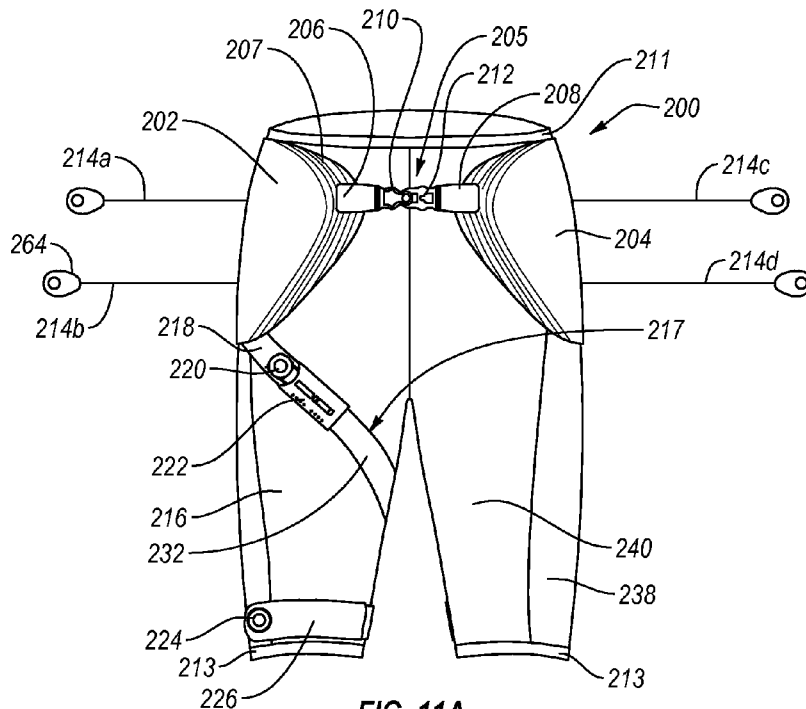

(57) Abstract: An orthopedic device (200) is provided for treating complications of the hip and has means for trochanter compression, pelvis support, lumbar compression, variously directed straps, and thigh support. The trochanter compression and an internal/external rotation strap (217) provide pain relief through compression and skin protection, unloading of joints through compression and sealing, and unloading by load transfer. Means (220) for adjustably dosing of straps enables pain management and ease of use.

WO 2014/116895 A1



(84) Designated States (*unless otherwise indicated, for every kind of regional protection available*): ARIPO (BW, GH, GM, KE, LR, LS, MW, MZ, NA, RW, SD, SL, SZ, TZ, UG, ZM, ZW), Eurasian (AM, AZ, BY, KG, KZ, RU, TJ, TM), European (AL, AT, BE, BG, CH, CY, CZ, DE, DK, EE, ES, FI, FR, GB, GR, HR, HU, IE, IS, IT, LT, LU, LV, MC, MK, MT, NL, NO, PL, PT, RO, RS, SE, SI, SK,

SM, TR), OAPI (BF, BJ, CF, CG, CI, CM, GA, GN, GQ, GW, KM, ML, MR, NE, SN, TD, TG).

Published:

— *with international search report (Art. 21(3))*

ORTHOPEDIC DEVICE FOR TREATING COMPLICATIONS OF THE HIP

[1] FIELD OF ART

[2] The embodiments of this disclosure are directed to orthopedic devices, particularly to a garment and/or hip orthosis for treating complications of the hip and methods for using the same.

[3] BACKGROUND

[4] Conventional hip braces and supports are mainly directed towards post-operative treatment of arthritis related surgeries (such as arthroplasties and arthroscopies). Few if any braces and supports are designed to treat osteoarthritis (OA) development or reduce the symptoms related to arthritis of the hip.

[5] Braces and supports can assist weak muscles such as gluteus medius believed to be implicated in the sensation of pain. Re-positioning of the joint is also considered to be beneficial for other indications, such as anterior-collateral-ligament (ACL) injuries, and may offer improved control of the knee. One particular group of patients at risk includes female athletes who experience pain caused by non-contact ACL injuries because of landing from a jump.

[6] A common problem with landing from a jump is a hyperextended knee position regarding the valgus causing internal rotation. It is believed that the root cause of this problem may be a weak gluteus medius causing the hip to over-extend and transfer the landing load onto the quadriceps instead of the gluteus medius. Therefore by flexing, abducting and externally rotating the hip one may alter the knee position and reduce the load on the ACL when landing from a jump.

[7] Re-positioning or encouraging a preferred position of the hip relative to the joint may also reduce the load in the medial compartment of the knee and control proper tracking of the patella. Patella pain may be caused by lateral shift. Most patella braces and supports attempt to push the patella medially, however, by rotating the femur externally one may achieve better results by moving the femur relative to the patella instead of trying to push straight on the patella. It is known that the medial compartment loading for an OA patient is linked to the adduction moment of the knee.

[8] It is more recently understood the medial compartment load is also linked to the knee extension moment. By rotating the femur externally, one may create a “toe-out” gait shown to reduce the load on the quadriceps and may directly reduce the load on the medial compartment.

[9] Hip orthoses may be used for preventing hip dislocation, and provide early mobilization after hip surgery while minimizing post-surgical complications. Certain surgical operations include hip joint replacements or complete or partial revision surgery, and hip arthroscopy. These orthoses can reduce the length of hospitalization and rehabilitation, and the total period for convalescence. Hip orthoses may also treat persistent hip pain and non-operable hip deformities.

[10] Prophylaxis of hip dislocation is a problem that occurs when the femoral head is displaced in the acetabulum or the hip socket. Typically, after hip surgery, a hip orthosis is needed for immobilization and support to aid in rehabilitation by preventing such a dislocation again.

[11] The head of the femur meets the pelvis at the acetabulum and forms the hip joint. The head of the femur ("femoral head") and the acetabulum form as a ball-and-socket joint that allows for flexion, extension, abduction, adduction and circumduction. The hip is arranged for weight bearing, and there are connective ligaments for supporting the hip joint. The trochanter of the femur is located generally opposite the femoral head, and includes a lateral surface that serves at the insertion of the tendon of the gluteus medius.

[12] Known hip orthoses used to prevent hip dislocation typically may have an adjustable hinge, which only allows for rotation of the upper leg about the hip joint in forward and backward directions. These hip orthoses have the drawback of failing to provide a dynamic abducting force on the leg throughout an entire range of motion. The abducting force may be provided while standing, but is not applied when sitting. Because the conventional orthoses hold the leg in abduction rigidly, this may lead to abnormal gait patterns and compliance issues.

[13] Like other joints, hips may develop osteoarthritis of the hip as the articular cartilage between the femoral head and the acetabulum breaks down. The breakdown of the cartilage causes pain, swelling and deformity. As a result of the osteoarthritis, a patient having osteoarthritis of the hip may have difficulty walking. While

osteoarthritis cannot be reversed, nonsurgical treatment may involve rest, anti-inflammatories and/or weight loss. If one has later stages of osteoarthritis of the hip, one may undergo total hip replacement surgery.

[14] The wear of cartilage is particularly troublesome when loads are placed on the hip. Although there are plenty of solutions for treating osteoarthritis of the knee, few, if any, braces and supports have been offered to successfully treat hip osteoarthritis, specifically for reducing a load on the hip. Thus, there is a need and demand for an orthopedic device arranged for treating hip osteoarthritis.

[15] Another concern regarding complications of the hip and associated vertebral column involves pelvic tilt and lordosis. Pelvic tilt refers to the orientation of the pelvis in regard to the femurs it rests upon and in space. There are various forms of pelvic tilt including anterior pelvic tilt result in front tilt and rear rising of the pelvis when hip flexors shorten and hip extensors lengthen, and posterior pelvic tilt involving front rise and rear tilt of the pelvis when hip flexors lengthen and the hip extensors shorten. Lateral pelvic tilt describes tilting in both directions.

[16] Lordosis is often associated with pelvic tilt, and is the inward curvature of the lumbar and cervical vertebral column. A major factor of lordosis is anterior pelvic tilt that results in the pelvis tipping forward when resting on top of the femurs. A variety of health conditions can cause lordosis and include imbalances in muscle strength and length such as in the hamstrings and hip extensors and flexors.

[17] Another spinal disorder is spinal stenosis that involves the abnormal narrowing of the spinal canal. One form of spinal stenosis is lumbar spinal stenosis that occurs at the lower back. In lumbar stenosis, the spinal nerve roots in the lower back are compressed which can lead to symptoms of sciatica. Sciatica refers to tingling, weakness or numbness radiating from the lower back and into the buttocks and lower legs.

[18] A variety of solutions exist for treatment of excessive pelvic tilt, lordosis and spinal stenosis of the lower back, however rare are solutions including orthopedic devices capable of treating both the hip and these aforementioned disorders.

[19] SUMMARY

[20] The orthopedic devices described are designed to reduce the load on the hip joint and encourage a positional shift of the joint believed to reduce pain by guiding

the hip away from areas having worn or damaged cartilage. With mobility improved or restored, a user can engage in various activities without limitations of a constantly painful hip. Increased mobility helps avoid weight gain that may exacerbate symptoms of osteoarthritis of the hip.

[21] According to a preferred embodiment, the orthopedic device is a garment and/or hip orthosis for treating complications of the hip. The garment and/or hip orthosis may provide means for trochanter compression, pelvis support, lumbar compression, variously directed straps, and thigh support. The trochanter compression and internal/external rotation strap provide pain relief through compression and skin protection, unloading of joints through compression and sealing, and unloading by load transfer. Adjustable dosing of straps enables pain management and ease of use. Reduced pelvis drop is allowed on the contralateral side by the pelvis support. The lumbar compression increases stability and support. Thigh support with a dosing system provides easy and consistent use for anchoring the orthopedic device on the leg, and hip adduction when required.

[22] The garment (for example, a pair of tights extending over the waist and at least the upper leg) according to this disclosure may protect primary arthroplasty patients at risk of dislocation, hip revision, recurrent dislocations, inoperable hip abnormalities or for preventative use in everyday living. Certain embodiments may also treat osteoarthritis of the hip, pelvic tilt, lordosis and spinal stenosis.

[23] Embodiments of the garment described secure and control the femoral head in the acetabulum by providing a dynamic force on the leg and hip socket to prevent dislocation and treat instances of osteoarthritis. Forces may be exerted on the trochanter to urge the femoral head into the acetabulum.

[24] The garment allows the user freedom of movement since the upper leg can move in all directions and not only in one direction while a desired interplay of forces can continue to act on the hip. This offers more comfort and the possibility of more efficient exercise of the muscles around the hip joint, which muscles may be weakened due to surgery.

[25] In a first embodiment, the garment includes an upper belt member or belt and a lower wrap securing about the knee and/or thigh to position and anchor garment onto a user's body. A plurality of straps is arranged on the garment in a plurality of

orientations to provide different directional forces over the user. The straps may be detachable and attachable at a plurality of predetermined locations. The straps may be also semi-elastic to encourage certain movements through their elasticity and softly prevent certain movements through their resistance. The prevention of movement is neither rigid nor stops movement but rather provides feedback and inhibits certain movement.

[26] The straps can be integrated into a garment. The functionality from the straps can be achieved using textile patterns where portions of the textile will have different elastic properties providing feedback, or straps integrated into the garment separately adjustable using hook and loop or other tightening methods. The straps may extend at least in part through various sleeves formed on the garment to control movement. The sleeves may be formed from inelastic material to stabilize the straps and provide additional support while not inhibiting the elasticity of the straps.

[27] The straps are preferably anchored at a first end to the garment and movably adjustable at a second, free end at various locations on the garment according to the tension and anatomy of the user.

[28] A flexion strap may be attached to the anterior portion of the belt and anterior portion of the lower wrap. The strap encourages flexion and prevents extension of the hip. An abduction strap may be attached to the lateral portion of the upper belt member and the lateral portion of the lower wrap. The abduction strap encourages abduction and prevents adduction of the hip.

[29] An exorotational strap may be attached to the lateral side over the posterior of the garment and spirals over the anterior side of the thigh and to the medial side towards posterior portion of the lower wrap. The strap encourages exorotation of the hip, and prevents endorotation. The strap encourages abduction and flexion of the hip, while preventing adduction and extension.

[30] The garment may include a waist strap or belt extending laterally about the pelvis and circumferentially tightening over the trochanter of the femur to encourage placing or securing the femoral head in the hip socket. A lower wrap or band may extend laterally near the knee and form part of the lower wrap to serve as an anchor point for at least the abduction and the exorotational straps. The lower wrap may

include first and second straps extending above and below the knee respectively, or the lower leg strap may be located singularly either above or below the knee.

[31] The hip orthosis according to this disclosure may protect primary arthroplasty patients at risk of dislocation, hip revision, recurrent dislocations, inoperable hip abnormalities or for preventative use in everyday living. Certain embodiments may also treat osteoarthritis of the hip. The hip orthosis may form part of the garment and/or be in supplement to the hip garment.

[32] Pain relief is achieved by various embodiments by applying pressure on the greater trochanter by using a tensioning system, such as a pulley-type, to tension the orthosis over the trochanter. The upper part of the garment may be made from a non-stretchable material to better transmit the force from the tensioning system to the trochanter area. Using an elastic strap creates rotation of the leg. The upper part of the strap is fixed to the back area of the garment. Depending on the required rotation, internal or external, the strap is taken between the legs and to the front of the thigh or directly to the front of the thigh and then in both cases secured to a lower tightening unit using a fastening device. Using a frame fastened to the garment once the tensioning system has been tightened and fully secured creates abduction of the leg.

[33] The orthopedic device, particularly the lumbar support in combination or considered alone with the tensioning system, may be used to improve immobilization of the lower back, by resisting flexion, extension, pelvic tilt, spinal rotation, and lateral bending. Another mechanism is pelvic stabilization in which the lumbar support maintains proper alignment of the pelvis in relation to the spine, and reduces pain in the lumbo-sacral region. Yet another mechanism is hydrostatic lift that occurs when the abdominal cavity is gently compressed, and the intra-abdominal pressure is increased. In yet another mechanism, the lumbar support introduces lordosis support or maintains lumbar support in order to provide correct lumbar lordosis for pain relief, spinal stabilization and improved posture.

[34] The orthopedic device may include a plate system in combination with the tensioning system, or the tensioning system alone whether by placement or structure, may provide lordosis support to exert pressure to introduce and maintain correct lumbar lordosis for pain relief, spinal stabilization and improved posture such as by decreasing lordosis and increasing pelvic tilt.

[35] Embodiments of the hip orthosis described secure and control the femoral head in the acetabulum by providing a dynamic force on the leg and hip socket to prevent dislocation and treat instances of osteoarthritis. This dynamic force mechanism follows the anatomical motion of the hip joint by maintaining the prescribed flexion and extension restrictions. Forces may be exerted on the trochanter to urge the femoral head into the acetabulum. Features of the hip orthosis attribute to a more stable and versatile orthosis over conventional braces.

[36] Because of the versatility in sizing of the garment, there is only need for a few sizes, and a clinician may make further size adjustments by trimming belt segments and various cables. The garment provides pain relief and comfort through compression and skin protection. The orthosis enables trochanter compression with an optional pad, which allows for pain relief by unloading through compression and sealing, and unloading by load transfer.

[37] The embodiments may include an internal or external rotation strap that permits adjustable dosing for pain management and versatility depending on whether internal or external rotation control is desired. The embodiments also allow for pelvis support by inhibiting reduced pelvis drop on a contralateral side. Lumbar compression is also allowed which increases stability and support. Thigh support is achieved with dial tensioning providing easy and consistent use for anchor and effective hip abduction when required.

[38] The hip orthosis according to this disclosure may protect primary arthroplasty patients at risk of dislocation, hip revision, recurrent dislocations, and inoperable hip abnormalities or for preventative use in everyday living. Certain embodiments may also treat osteoarthritis of the hip.

[39] In an embodiment of the hip orthosis, it may include a spring assembly for operatively preventing adduction movement of an upper leg by a spring force. The spring assembly operatively exerts a force and/or a moment on the upper leg which makes the upper leg abduct, viewed from the front side of the person, preferably independently of the position of the upper leg regarding the trunk.

[40] The hip orthosis allows the user freedom of movement since the upper leg can move in all directions and not only in one direction while a desired interplay of forces can continue to act on the hip. This offers more comfort and the possibility of more

efficient exercise of the muscles around the hip joint, which muscles are weakened due to surgery.

[41] In use, the spring assembly exerts a force on the hip joint, such that the hip is pressed into its socket under the influence of that force, so the risk of dislocation is reduced further. The spring assembly also exerts a moment on the hip joint. This allows the upper leg to be given a preferred position regarding the trunk and/or to rotate it to a preferred position. The moment is directed so the upper leg is rotated substantially outwards, at least into a direction transverse to the sagittal plane. This prevents excessive abduction of the upper leg (towards the other leg), and reduces the risk of hip dislocation.

[42] Other embodiments of the hip orthosis may be hingedly attached to the garment, such at a portion located above the knee. The hip orthosis may be without the spring assembly, but rather include a strut connecting at one end to a trochanter support and another end to the garment above the knee.

[43] BRIEF DESCRIPTION OF THE DRAWINGS

[44] These and other features, aspects, and advantages of the embodiments will become better understood regarding the following description, appended claims, and accompanying drawings.

[45] Fig. 1 is a perspective front view of an embodiment of a garment according to the disclosure.

[46] Fig. 2 is a perspective rear view of the garment according to Fig. 1.

[47] Fig. 3 is a side view of the garment according to Fig. 1.

[48] Fig. 4 is a detailed lateral side view of the garment according to Fig. 1.

[49] Fig. 5 is a detailed medial side view of the garment according to Fig. 1.

[50] Fig. 6 is a schematic view of the garment according to Fig. 1 showing the directional forces created by tensioning various straps.

[51] Figs. 7A-7C are side, front and rear views of another hip orthosis embodiment according to the disclosure.

[52] Fig. 8 is a schematic view of the hip orthosis of Figs. 7A-7C with the first belt segment open showing a trochanter support.

[53] Figs. 9A-9B are side and front views showing the hip orthosis of Fig. 1 in combination with a compression belt on a user.

[54] Figs. 10A-10B are side and front views showing another hip orthosis embodiment according to the disclosure.

[55] Figs. 11A is a front view showing another hip orthosis embodiment according to the disclosure.

[56] Fig. 11B is a schematic view showing opening of the hip orthosis of Fig. 11A and installation of a trochanter pad.

[57] Fig. 12 is a rear view showing the hip orthosis of Fig. 11A.

[58] Fig. 13 is a detailed view showing a rear view of the compression system without a cover.

[59] Fig. 14 is a detailed view of a set of pulleys in the compression system in the hip orthosis of Fig. 11A.

[60] Fig. 15 is a schematic view of a buckle assembly in the hip orthosis of Fig. 11A.

[61] Fig. 16 is a detailed view of the lower support in the hip orthosis of Fig. 11A.

[62] Fig. 17 is a schematic view of the lower support in Fig. 16 and attachment of straps.

[63] Fig. 18A is a plan view of a support element in the lower support of Fig. 17.

[64] Fig. 18B is a front view of a strap of the lower support in Fig. 17.

[65] Figs. 19 is a perspective view of another hip orthosis embodiment according to the disclosure.

[66] Figs. 20-22 are rear, front and side views of the hip orthosis embodiment of Fig. 19.

[67] Fig. 23 exemplifies views of another hip orthosis embodiment according to the disclosure.

[68] Fig. 24 includes schematic views showing a hip orthosis embodiment arranged for derotational strapping in a hip.

[69] Fig. 25 includes schematic views showing another hip orthosis embodiment arranged for derotational strapping in a hip.

[70] Fig. 26 includes schematic views showing another hip orthosis embodiment arrangement for rotational strapping in a hip.

[71] Figs. 27 and 28 disclose frontal and rear views of a strut assembly for use with embodiments described herein.

[72] Fig. 29 is a schematic view of a length adjustment assembly for tensioning devices.

[73] Fig. 30 is a perspective of an embodiment of a hip orthosis according to the disclosure.

[74] Fig. 31A is a perspective view of an adjustment assembly of the hip orthosis according to Fig. 30.

[75] Fig. 31B is another perspective view of the adjustment assembly of the hip orthosis according to Fig. 30.

[76] Fig. 32 is a detailed sectional side view showing an upper portion of the hip orthosis according to Fig. 30.

[77] Fig. 33 is a detailed view showing adjustment of the pivot adjustment mechanism in the hip orthosis according to Fig. 30.

[78] Fig. 34 is a detailed view showing adjustment of the pressure adjustment mechanism in the hip orthosis according to Fig. 30.

[79] Fig. 35 is a detailed sectional rear view showing a lower portion of the hip orthosis according to Fig. 30.

[80] Fig. 36 is schematic view showing another embodiment of the orthopedic device.

[81] Fig. 37 is a perspective view showing a frame assembly in the orthopedic device of Fig. 36.

[82] DETAILED DESCRIPTION OF VARIOUS EMBODIMENTS

[83] A. Environment and Context of Embodiments

[84] For further ease of understanding the embodiments of an orthopedic device in the exemplary form of a garment and/or hip orthosis for treating complications of the hip and variants as disclosed, a description of a few terms is necessary.

[85] The terms “rigid,” “flexible,” “compliant,” and “resilient” may distinguish characteristics of portions of certain features of the straps and garment. The term “rigid” should denote an element of the device is generally devoid of flexibility. Within the context of features that are “rigid,” it is intended to indicate that they do not lose their overall shape when force is applied, and may break if bent with sufficient force. The term “flexible” should denote that features are capable of repeated bending such that the features may be bent into retained shapes or the features do not retain a general shape, but continuously deform when force is applied.

[86] The term “compliant” may qualify such flexible features as generally conforming to the shape of another object when placed in contact therewith, via any suitable natural or applied forces, such as gravitational forces, or forces applied by external mechanisms, for example, strap mechanisms. The term “resilient” may qualify such flexible features as generally returning to an initial general shape without permanent deformation. As for the term “semi-rigid,” this term may be used to connote properties of support members or shells that provide support and are freestanding; however such support members or shells may have some degree of flexibility or resiliency. The term “elastic” may connote stretchability, and the term “semi-elastic” connotes various degrees of elasticity as compared to the term “inelastic” which may mean devoid or substantially devoid of any elasticity.

[87] The embodiments of the disclosure are adapted for a human body, and may be dimensioned to accommodate different types, shapes and sizes of human body sizes and contours. For explanatory purposes, the orthopedic device embodiments described are referred to as corresponding to different sections of a body and are denoted by general anatomical terms for the human body.

[88] For explanatory purposes, each orthopedic brace embodiment or component described may be divided into sections denoted by general anatomical terms for the human body. Such anatomical terms are provided to distinguish various elements of the brace embodiments from one another, but which are not to be considered to limit the scope of the invention.

[89] Each of these terms is used in reference to a human leg, for example, which is divided in similar sections with a proximal-distal plane extending along the meniscus of the knee between the femur and tibia. The terms "proximal" and "distal" refer to locations of the brace that correspond to the location of the leg relative to the point of attachment of the leg to the body. The terms "upper" and "lower" may be used in combination with "proximal" and "distal" to connote gradations in location of "proximal" and "distal." The location at where the brace corresponds to the knee joint is used to generally delimit the proximal and distal sections of the brace.

[90] The embodiments of the knee brace can also be considered to fall within "anterior" and "posterior" sections by an anterior-posterior plane. The anterior-posterior plane generally corresponds to the coronal or frontal plane of a human leg lying along the central longitudinal axis of a body. A posterior side or element is therefore located behind this anterior-posterior plane, whereas an anterior side or element is in front of the anterior-posterior plane.

[91] The terms "inwardly" or "inner" commonly used to distinguish the side of the brace may be directed to the posterior side of the brace and adjacent to the leg of the user of the brace. Contrariwise, the terms "outwardly" or "outer" are used to denote the side of the brace opposite to the inwardly side.

[92] The terms "medial" and "lateral" are relative terms generally understood as indicating location near the midsagittal plane or midline. Therefore, elements located near the midline are referred to as "medial" and those elements further from the midline are "lateral." The term "central" is used to denote the area along the midline of a joint dividing and sharing regions of the medial and lateral regions.

[93] The term "adduction" is defined as being a movement towards the trunk. The term "abduction" is defined as being a movement by which a body part is moved away from the axis of the body.

[94] The hip region is commonly considered as being located lateral to the gluteal region (i. e. the buttock), inferior to the iliac crest, and overlying the greater trochanter of the femur, or "thigh bone". In adults, three of the bones of the pelvis have fused into the hip bone that forms part of the hip region.

[95] The hip joint, scientifically referred to as the acetabulofemoral joint, is the joint between the femur and acetabulum of the pelvis and its primary function is to

support the weight of the body in both static (e. g. standing) and dynamic (e. g. walking or running) postures. The pelvic inclination angle, which is the single most important element of human body posture, is adjusted at the hips.

[96] The pelvis is referred to as either the lower part of the trunk, between the abdomen and the thighs (sometimes also called pelvic region of the trunk), or the skeleton embedded in it (sometimes also called bony pelvis, or pelvic skeleton). The pelvic region of the trunk includes the bony pelvis, the pelvic cavity (the space enclosed by the bony pelvis), the pelvic floor, below the pelvic cavity, and the perineum, below the pelvic floor. The pelvic skeleton is formed in the area of the back, by the sacrum and the coccyx and anteriorly and to the left and right sides, by a pair of hip bones. The two hip bones connect the spine with the lower limbs. They are attached to the sacrum posteriorly, connected to each other anteriorly, and joined with the two femurs at the hip joints.

[97] The waist or waist region is the part of the abdomen between the rib cage and the hips, and is often the narrowest part of the torso on proportionate people. The thigh or thigh region is considered the area between the pelvis and the knee.

[98] The term "adduction" is defined as being a movement towards the trunk. The term "abduction" is defined as being a movement by which a body part is moved away from the axis of the body.

[99] B. Various Embodiments of the Orthopedic Brace and Components for Use Therewith

[100] In reference to Figs. 1-5, a garment 10 for treating complications of the hip is illustrated. The garment includes an upper wrap 12 in a belt, a main body portion 14 extending over the thighs, and a lower band or wrap 16 located near the knees K. The upper and lower wraps 12, 16 serve as anchors to securing the garment on the user, and likewise for various straps attached to the garment. The lower wrap 16 may be secured below or above the knee, or both.

[101] The belt 12 is attached around the user's pelvis/waist, anatomically shaped, and tightened using hook and loop, buckles or other fastener means. The belt 12 includes first and second belt segments arranged to overlap and secure to one another. By circumferentially compressing over the user's waist, the belt forms an upper anchor to the garment.

[102] The belt 12 is preferably formed from a stretchable and compressible material arranged to extend over the user's waist and pelvis. The belt can have silicone patches integrated into the textile that creates a frictional interface to the skin or the user's undergarments to reduce migration, as shown in Fig. 6 under reference 46. The belt can be arranged with a tensioning or pulley system similar to a lumbar belt discussed in U.S. patent 8,172,779, granted on May 8, 2012. The embodiments are not limited to pulleys and may include posts, sliders or other means for providing mechanical advantage for a cable. Alternatively, the tensioning system may be a plurality of straps replacing pulleys, cables and similar means.

[103] A lateral strap 18 may be secured at a first end to the posterior of the garment and extend about the user's pelvis. The lateral strap 18 has a second end adjustably attachable to the garment. The lateral strap 18 is intended to provide localized and enhanced pressure over the user's trochanter to maintain the femoral head in the user's socket.

[104] The body portion 14 may be formed from a generally sturdy fabric elastic material, such as Lycra or Spandex. The body portion 14 is configured to conform to the legs of the user and provide an interface over which the straps extend.

[105] The lower wrap 16 may form a knee/thigh wrap anatomically shaped to slip onto the leg. The wrap can be solely around the thigh, or extend down below the patella. The knee/thigh wrap can have a hole for the patella, and include straps in the bottom, middle or top portion that allows for tightening to avoid migration. The wrap can also have integrated silicone patches, as discussed in connection with the upper wrap, to provide frictional resistance.

[106] In the embodiments of Figs. 2-5, the lower wrap 16 is arranged as a lateral strap extending adjacent to and below the user's knee. The lower wrap 16 forms a lower anchor to the garment, and prevents migration of the garment on the lower leg. In this configuration, the lower wrap 16 forms a gastroc strap that corresponds to the gastroc and secures the brace in place between the knee and the user's calf by the shape of the user's calf to inhibit migration. Alternatively, the lower wrap 16 may be located so it extends adjacent to and above the user's knee.

[107] The lower wrap 16 may include a lower strap 32 allowing for tensioning of the lower wrap 16 over the leg. The lower wrap 16 may define an elasticized portion of

the garment 10 having a channel through which the lower strap 32 extends. The lower wrap 16 is yet further tightened over the user's leg by adjustment of the elastic strap 32 relative to the channel. The lower strap 32 may be inelastic or elastic.

[108] In a variation of the lower wrap 16 depicted in Fig. 1, the lower wrap 16 includes an upper circumferential strap 40 arranged to extend about the lower thigh above the knee, and a lower circumferential strap 50 arranged to extend about the lower leg below the knee. Medial and lateral elongate straps 42, 44 extend transversely relative to and connect the upper and lower circumferential straps 40, 50 to keep them secured to one another.

[109] A longitudinal band or abduction strap 20 extends longitudinally along the lateral side of the garment, and is arranged to encourage abduction and prevents adduction of the hip. The abduction strap 20 is anchored at point 34 above the lower wrap 16, and is adapted to extend to the upper wrap 12 so a free end 28 secures to the upper wrap 12.

[110] The body 14 may define a sleeve 24 having an opening 36 through which the abduction strap 20 extends from the lower wrap 16 to the upper wrap 12. The sleeve 24 has a greater width than the abduction strap 20 to permit adjustment of the abduction strap 20 relative to the sleeve 24. The sleeve 24 may be formed at least in part from a material inelastic to stabilize and support the area of the leg corresponding to the sleeve 24.

[111] An oblique band or exorotational strap 22 extends from an anchor point at the posterior of the leg wrap 16 and spirals toward the medial posterior of the leg, over the anterior thigh and has a free end 26 securable to the posterior lateral side near or at the upper wrap. The exorotational strap 22 extends through a channel 30 formed from the lower wrap to a location on the anterior side of the garment. The channel 30 is wider than the exorotational strap 22 and is formed at least in part from a material inelastic to stabilize and support the exorotational strap 22 over the leg. The channel 30 assists in distributing pressure over the leg.

[112] The garment 10 may be provided with a flexion strap 38 arranged from the lower wrap 16 and securing to the upper wrap 12 along the anterior of the garment generally along the midline. The flexion strap encourages flexion and prevents extension of the hip.

[113] In a variation, the garment may be provided with an extension strap arranged on the posterior of the garment generally along the midline. The extension strap encourages extension and resists flexion.

[114] Fig. 6 depicts various forces incurred by the various straps. The lateral strap 18 provides a circumferential force F_1 about the pelvis to apply to the trochanter. The abduction strap 20 provides an upwardly force F_2 from the knee to the pelvic to prevent adduction of a user's leg. The exorotational strap 22 provides a spiraling force F_3 generally oblique to the forces F_1 , F_2 , to encourage abduction and therefore resist adduction. The lower strap 16 provides a circumferential force F_4 to anchor a lower portion of the garment.

[115] As shown in Figs. 7A-7C, another embodiment of a hip orthosis includes a pelvic compression support 100 adapted to be secured about the user at the pelvis. This arrangement is distinguishable from a lumbar compression support discussed in U.S. 8,172,779 provided about the waist and intended to provide compression to the lumbar area of the user. The pelvic compression support 100 has a more significant width 112 than a conventional lumbar support, and is arranged to sit over the hips including the trochanter resting at least partially below a lumbar region of the user's back unlike the conventional lumbar support.

[116] The pelvic compression support 100 includes first and second belt segments 102, 104 extending from a rear or posterior compression system 106 discussed more fully in U.S. 8,172,779. Tensioning devices 108, 110 extend from the compression system 106, and are intended to provide compressive adjustment to the rear compression system 106 and secure over the first and second belt segments 102, 104. Multiple tensioning devices may be provided on each side of the compression system. Each side may include upper and lower tensioning devices each selectively adjusting various locations of the compression system.

[117] Fig. 8 shows a trochanter support 114 located underneath the first belt segment 104, and adjacent the user's body. As the first and second belt segments 102, 104 are secured to one another, and the tensioning devices 108, 110 are used to tension the rear compression system, compressive support is provided particularly at the trochanter support 114, which urges the femoral head into the hip socket (acetabular)

to provide relief to the user. The garment may be provided with inelastic fabric that is hook receivable to include a trochanter pad carried by the trochanter support.

[118] Figs. 9A and 9B show the hip orthosis of Fig. 1 in combination with a compression belt or upper wrap 150. Unlike the compression belt of Figs. 7A-7C, the compression belt 150 sits higher toward the waist of the user by a difference 156, and has a narrower width 158.

[119] In this embodiment, the pelvic support 12 is located adjacent the user and underneath a first belt segment 152 which secures to a second belt segment 154. A pad 70 covering at least part of the pelvic support 12 may be retained by the pelvic support 12 to the first belt segment 152.

[120] An exorotation strap 71 secures to a strut assembly 121 at an upper anchor 78 and wraps around the leg and secures to a lower anchor 80 on the lower support 16. The exorotation strap 71 defines a first segment 72 depending from the upper anchor 78 and couples to a second segment 74 by a tensioning device 76 providing incremental tensioning of the exorotation strap 71. The tensioning device 76 may correspond to the strap tightener assembly for an orthopedic device according to U.S. application no. 13/739,491, filed on January 11, 2013. Alternatively, the exorotation strap 71A (shown in dashed lines) may run underneath the strut assembly 121 and secure to the posterior side of the upper wrap 150.

[121] The strut assembly 121 includes a strut 123 connecting to the lower wrap 16 and the pelvic support 12. The strut may carry a trochanter support 114, and a strut adjustment or pivot mechanism 35 may adjust position of the trochanter, as discussed more fully regarding the strut assembly of Fig. 30.

[122] Figs. 10A-10B show another embodiment of a hip orthosis employing the compression belt 150 of Figs. 9A-9B and the exorotation strap 71 attached directly to a generally posterior side of the compression belt 150 on a lateral side of the leg. The tensioning device 76 is secured directly to the compression belt and allows for adjustment of the exorotation strap 71. The tensioning device 76 allows for tensioning of the second strap segment 74, which couples to the lower support 16. A strap support 82 may be in combination with the exorotation strap 71 to distribute pressure over the thigh.

[123] Referring to the embodiment of Figs. 11A-18, the orthopedic device 200 combines a garment and hip orthosis and includes first and second upper belt members 202, 204 adapted to wrap about a user's hip. A waist band 211 is located at a generally uppermost portion of the orthopedic device, and is adapted to secure to the waist of the user. Lower bands 213 are located at generally lowermost portions of the orthopedic device, and the inside surface of the lower bands 213 may include a frictional interface to engage the skin and prevent migration of the garment on the user.

[124] The upper belt members 202, 204 having posterior or lateral ends that are joined to the garment 216 on the lateral and/or posterior sides of the orthosis by a joint 244 such as permanently by stitching or removably by hook and loop fastening. The upper belt members 202, 204 freely extend from the joint or stitching, and have anterior ends that are secured to one another by a buckle assembly 205. The anterior ends of the upper belt members have trimmable sections 207 bordered by trim lines allowing for sizing of the upper belt members to the specific dimensions of an individual user. The trim lines may be reduced thickness regions of the upper belt members.

[125] The shape of the anterior side of the belt members is significant in that it extends more substantially toward the upper portion of the garment, although preferably at its greatest slight below, as shown in Fig. 11A, and tapers in the extent it extends anteriorly toward the lower portion of the garment. The height of the belt members is preferably at its greatest at the joint to distribute forces created when the belt members are secured to one another. The tapering height of the belt members tracks generally the anatomy of the pelvic region of the user so that the anterior-most portion does not interfere with normal activities.

[126] The garment 216 may include different sections having different stretchability, stiffness, or carry various surface textures for securing to various straps. Lateral portions 238 may have a stiffer property than portions 240 outside of the lateral portions 238. The lateral portions may be reinforced or possess the stiffer properties to provide additional resistance for controlling movement of the hip and legs. The lateral portions may also be substantially inelastic as compared to other portions of the garment outside the lateral portions.

[127] Fig. 11B shows insertion of a trochanter pad 267 along an inner surface of the upper belt member 206. The trochanter pad 267 may be removably secured along the inner surface by a hook and look system, whereby the trochanter pad 267 includes a hook material segment arranged to be secured to loop material formed along the inner surface. The trochanter pad 267 may have a pocket 269 arranged for receiving a frame element of a strut assembly, as discussed herein.

[128] Observing Figs. 11A and 15, the buckle assembly 205 includes first and second segments 206, 208 depending from the first and second belt members 202, 204. The first and second segments may be trimmable to size according to an individual user, and may be elastic or inelastic. The first and second segments 206, 208 may comprise “alligator” type hook clamps forming opposed hook surfaces arranged to clamp onto a hook receivable surface of the first and second belt members.

[129] The first segment 206 carries a tab 210 having a catch 258, such as a pin or other protrusion, adapted to be received by a clip 212 carried by the second segment 208, thereby forming a buckle. The clip 212 may define a plurality of engagement openings 260, 262 for receiving and allowing the catch 258 to engage with the clip 212.

[130] Each of the engagement openings 260, 262 is sized and configured for quick attachment of the catch 258. In the depicted embodiment, a larger opening 261 permits insertion of the catch 258 therethrough and a smaller opening 263 continuously depends from the larger opening 261 so the tab 210 can be pulled toward an end of the clip 212 to firmly engage the catch 258 within the smaller opening 263.

[131] The orthosis 200 includes tensioning devices 214A-214D arranged for tensioning a compression system 229, and arranged to function similarly to the compression system in the embodiment of Figs. 7A and 7B. Tensioning devices 214A and 214B correspond to the first belt member 202 and tensioning devices 214C and 214D correspond to the second belt member 204. Handles 264 of the tensioning devices are secured to the upper belt members, which may bear hook receivable material, and the handles themselves may carry hook material. As the compression system 229 is arranged on the posterior of the hip orthosis 200, the tensioning devices extend freely from the compression system 229 and pulling of the tensioning devices from the compression system 229 tensions the compression system over the pelvis.

[132] As shown in Figs. 13 and 14, the compression system 229 includes a plurality of tensioning sets such as those including pulleys 242A- 242D corresponding to the tensioning devices 214A-214D. The pulley sets function in a manner similarly as the pulley sets described in U.S. 8,172,779, in that the pulley sets include pulleys 248 corresponding to each tensioning device 214A-214D, and anchors 250 for each tensioning device. A cover 231 may be provided to cover the compression system 229.

[133] In this embodiment, as the first and second belt members 202, 204 may be stitched at their posterior ends to the garment 216 by the joint 244, the distance between the pulley sets 242A-242D is adjustable to provide tension on the pelvis. The stitching occurs along a plurality of openings 246 formed along a tab of the pulley sets such that the belt members extend toward the anterior side of the garment from the joint and the tensioning sets extend toward one another posteriorly from the joint. The belt members and the tensioning sets preferably are arranged to counteract one another.

[134] An oblique band or exorotation strap 217 secures at one end to an anchor 230 protruding from the pulley sets. The upper belt members 202, 204 may each define an opening 236, 238 through which the exorotation strap 217 can secure so as not to interfere with operation of the belt members 202, 204, and the exorotation strap 217.

[135] The exorotation strap 217 may include a tab 228 having means such as a keyhole to secure to the anchor 230. As with the embodiment of Figs. 9A and 9B, the exorotation strap 217 defines a first segment 218 depending from the upper anchor 230 and couples to a second segment 232 by a tensioning device 220 and indicia sleeve 222 which provides incremental tensioning of the exorotation strap 217.

[136] The exorotation strap may be arranged on the leg in different orientations depending on the desired rotation, internal or external. The strap is either taken between the legs and to the front of the thigh or directly to the front of the thigh or then in fastened to a lower portion of the garment.

[137] Referring to Figs. 11A, 12 and 16, a lower tightening unit or wrap 226 includes a junction 227 for receiving the second segment 232 of the exorotation strap 217 and carries a dial tensioning unit 224 for adjusting the tightness in the lower wrap 226. In the illustrated embodiment of Fig. 16, the lower wrap 226 has a strap 252

with opposed ends connected to locking elements or buckles 254, 256 enabling quick attachment to secure the lower wrap onto the leg. The locking elements 254, 256 may secure about the junction 227 with the second segment of the exorotation strap.

[138] Referring to the embodiment of Figs. 17 and 18A, the lower wrap 226 includes an elongate tab 264 carrying an anchor point 268 and replacing the buckle 254 in Fig. 16. The anchor point 268 is used to secure to the locking element 256 carried by a second end of the strap 252, whereas the tab 264 connects to a first end of the strap 252. The tab 264 includes another anchor 266 extending along a rear portion of the tab and adapted to secure to a locking element 272 carried by the second segment 232 of the exorotation strap.

[139] The tab 264 carries a dial tensioning device 224 coupled to a cable system 269 securing to the first end of the strap 252. The dial tensioning device 224 allows for fine adjustment of the tensioning of the strap 252.

[140] The exorotation strap may be formed from an elastic or inelastic material. In the depicted embodiments, the exorotation strap is elastic. The exorotation strap is preferably trimmable in length at both ends for correct placement of the tensioning device over the user's leg. The exorotation strap may removably secure to the tensioning device 220 and the lower wrap 226 by means such as "alligator" type hook clamps and/or with keyhole connections. A pad may be on a body facing surface of the indicia sleeve 222 to provide for improved comfort.

[141] The lower wrap strap 252 is preferably an elastic strap for improved comfort. Alternatively, the lower wrap strap may be inelastic or elastic, and formed from a loop material/foam material/loop material laminate.

[142] Fig. 18B shows the strap 252 as having an elastic segment 263 with an inelastic segment 259 located at a first end carrying the locking element 256 with a keyhole 257. The strap 252 includes a sleeve 265 extending over a second end of the strap carrying the dial-tensioning device 224. The second end of the strap carries the anchor point 268, which is arranged to couple with the locking element 256 on the second end. The second end, by the dial tensioning device features or otherwise may be inelastic so the elasticity of the strap 252 is confined by the elastic segment 263 that provides comfort to the user. Of course other combinations of elastic and inelastic segments may be envisioned for the strap.

[143] Any of the orthopedic device embodiments may be provided with a plate system arranged for securing against at least the lumbar region and/or abdomen of the user. Various back plate systems useable with the orthopedic device embodiments may be found in U.S. patent 8,172,779. The difference from the lumbar-sacral orthosis in U.S. patent 8,172,729 is that the orthosis in such patent is arranged as a lumbar belt whereas the embodiments described herein are arranged for the hip and pelvis. The embodiments herein may be configured with at least a higher posterior portion to accommodate a plate system or have a connection for plate system to extend above the orthopedic device for placement against a lumbar region if the orthopedic device is configured for securing below such region.

[144] For example, a back plate may slidably connect to the posterior portion of the orthopedic device. According to this embodiment, the back plate is flexible or bendable to accommodate the anatomy of a wearer's back when the closure system is employed. The ability to bend about the wearer's back is particularly advantageous since the back plate can be used to support a variety of anatomical contours of a single wearer or a variety of wearers. However, while the back plate is bendable about the wearer's back, it provides sufficient rigidity to support the lumbo-sacral region of the wearer. In an alternative, the back plate may be custom formed so as to correspond to exact contours of a particular wearer wherein the back plate is substantially rigid or semi-rigid.

[145] The back plate of the plate system may have a particular anatomical geometry that is arranged to closely accommodate a wide variety of different back anatomies. For example, the plate may be configured to relieve pressure over a spinal region of a human back by having an outwardly directed curvature generally protruding away from the spinal region. The plate may be arranged to apply even pressure over a paraspinal musculature of a human back by having an inwardly directed contour extending over the paraspinal musculature. The plate may include side wing portions which are inwardly contoured toward the wearer, a tapered top portion and generally rounded side portions, which provide coverage over side portions of the lumbar region of a wearer's back, and contribute to better pressure distribution over sensitive and less sensitive areas of a wearer's back.

[146] The plate may define a general arcuate contour providing lordosis support for the wearer. This contour, in combination with pressure exerted on the plate via the

closure system, introduces and maintains correct lumbar lordosis for pain relief, spinal stabilization and improved posture, such for decreasing lordosis and increasing pelvic tilt. Because the plate is anatomically contoured with the aforementioned features, better hydrostatic lift is also created when the abdominal cavity is gently compressed and the intra-abdominal pressure is increased.

[147] As discussed in U.S. patent 8,172,729, the anatomical shape of the plate creates better pelvic stabilization since it is arranged to properly align the pelvis in relation to the spine, thereby reducing pain in the lumbo-sacral region of a wearer's back. Again, in combination with closure system, the plate allows for improved immobilization of a wearer's back by immobilizing flexion, extension, pelvic tilt, spinal rotation and lateral bending.

[148] Referring to Figs. 19-22, a hip orthosis 300 embodiments is shown wherein exorotational straps 302, 304 are arranged in a neutral configuration to keep the hip in neutral position and to restrict both internal and external rotation. Both upper ends of the exorotational straps 302, 304 are secured to an upper anchor point 306 on the compression system and to a lower anchor point 308 on the lower wrap 314.

[149] Figs. 19-22 exemplify how the exorotational straps 302, 304 may be anchored to the belt member 310 with a tensioning system and the lower wrap 314 without the necessity of a garment, as described in various embodiments herein. The upper and lower wraps 310, 314 may be connected with an elongate lateral segment 312 which may include a strut assembly.

[150] Fig. 23 shows an embodiment without a belt member, rather the embodiment includes a garment 320 on which the exorotation strap 322, 324 secures to a posterior portion or panel 326 and a lower wrap 328 of the embodiments described herein. In this embodiment, exorotation straps are on both legs for stabilization of both hips.

[151] Fig. 24 exemplifies an embodiment in which the strap provides derotational strapping in the hip. In the configuration in Fig. 24, there is minimal rotation, minimal abduction and little or no flexion resistance or assistance. The strap 340 includes a lower wrap 342 having portions that may extend above and below the knee to anchor the strap 340. A rotational strap 344 extends from the medial side of the lower wrap and spirals along the medial leg and over the buttocks to an upper belt

member 346 at about a frontal or anterior portion of the hip generally between the lateral and medial sides.

[152] Fig. 25 offers another configuration of the strap 340 including the lower wrap 342 and the rotational strap 344 in the embodiment of Fig. 24. Similarly to the embodiment of Fig. 24, the rotational strap 344 extends from the medial side of the lower wrap 342 and spirals along the medial leg and over the buttocks. Unlike in the configuration of Fig. 24, the rotational strap 344 is secured to a lateral side of the upper belt member 346. In this configuration, there is internal rotational and abduction control, and flexion and resistance and extension assistance.

[153] Referring to the embodiment of Fig. 26, a variation of the hip orthosis of Figs. 10A-10B or Figs. 24-25 is employed in combination with a derotational strap 350. The derotational strap 350 secured to the lower wrap 342. In this configuration, the rotational strap 344 is arranged to extend from the medial side of the lower wrap 342, over the anterior thigh and secures to the lateral side or lateral-posterior side of the upper belt member 346.

[154] Besides the rotational strap 344, the derotational strap 350 extends from a lateral side of the lower wrap 342 whereat a lower end 352 secures to the lower wrap 342, crossing over the rotational strap as it is directed toward the medial side of the thigh, about the lateral waist and securing to the upper belt member 346 and secured to a plurality locations on the upper belt member. As shown, the derotational strap 350 has an upper end 354 securing over the hip above the other leg. According to this configuration, the hip orthosis provides internal and external rotation control.

[155] Figs. 27 and 28 exemplify a strut assembly 360 for use with the hip orthosis for connection to the upper and lower wraps in the embodiments disclosed herein. The frame 360 includes a strut 362 extending between an upper frame 364 and a lower connection 368 to the lower wrap 226. The lower connection 368 may secure to the lower wrap 226 to an anchor such as the anchor 266 disclosed with the embodiment of Figs. 17 and 18 whereby a pin or button 374 secures within a slot 368 defined by the lower connection.

[156] The strut 362 has a pivot point 366 within upper frame 364, and the upper end of the strut 362 can slidably engage within a recess or area 370 defined within the upper frame 364 to accommodate movement of the user. The strut 362 may be rigid

or substantially rigid to provide for additional thigh support. As shown in Fig. 9A, the strut 362 may carry a trochanter pad to urge against the trochanter.

[157] The frame 360 may be configured to be attachable and detachable to the hip orthosis embodiments described herein. The garment may include pockets to receive the upper frame, or the upper frame may be attached by hook and loop fasteners. The upper frame may be flexible to accommodate the shape of the hip of the user. The strut may reduce or prevent adduction and provides more rigidity to the orthosis to avoid the risk of dislocation.

[158] Fig. 29 shows an embodiment of a length adjustment assembly for the tensioning device or cable 400. The handle 402 is flexible and defines a pocket 408. The embodiment includes a retainer 404 arranged for wrapping excess or an undesired length 406 of the cable 400 thereabout. The retainer 404 may include grooves or channels 410 arranged to hold the cable 400. The pocket 408 is sized and configured to accommodate the retainer 404 and excess length 406.

[159] The embodiments of Figs. 30-35 are directed to an embodiment of a hip orthosis arranged to maintain an upper leg positioned correctly regarding a trunk during use.

[160] In reference to the embodiment of Fig. 30, the hip orthosis 510 includes a pelvic support 512, a trochanter support 514 and a lower support 516. The pelvic support 512 is arranged for placement at or near the pelvis of the wearer, whereas the trochanter support 514 is arranged for placement at or near the trochanter of the femur opposite the femoral head. The lower support 16 is preferably arranged near and above the knee of the wearer. The pelvic, trochanter and lower supports 512, 514, 516 are connected to one another by a strut assembly comprising at least upper and lower struts 518, 520.

[161] The strut assembly comprises a leaf spring from, for instance, metal or plastic. Due to the resiliency of the strut assembly, the hip orthosis can exert a force and/or a moment on the upper leg, which makes the upper leg abduct, viewed from the front side of the person, preferably independently of the position of the upper leg regarding the waist or trunk. The wearer has more freedom of movement, since the upper leg can preferably move in all directions.

[162] The upper strut 518 has a first end slidably connected to the pelvic support 512 by a slot formed by the upper strut 518 and a fastener 524 extending through and securing against the pelvic support 512 and the upper strut 518. By loosening the fastener 524 from the pelvic support 512, the pelvic support 512 can be slidably adjusted along the length of the upper strut 518 to accommodate the wearer's size. At least one strap 526 secures through slots 527 formed along the pelvic support, and is sized and configured to extend around the trunk, waist or pelvis of the wearer to anchor the hip orthosis at an upper end of the wearer's leg.

[163] In referring to Figs. 31A-32, a second end of the upper strut 518 is pivotally connected to a first end of the lower strut 520 by a hinge 528. The hinge 528 has a plate 558 secured to an outer surface of the upper strut 518 and permits the lower strut 520 to pivot away from the outer surface of the upper strut 518. Both the upper and lower struts are preferably resilient bars or plates, and are flexible and resilient so they return to a predetermined shape after they are bent.

[164] A strut adjustment or pivot mechanism 535 is secured to the second end of the upper strut 518, and to the first end of the lower strut 520. The pivot mechanism 535 includes a dial 536 and a pin 538 connected to the dial 536. A first end of the pin 538 is coupled to the upper strut 518 by a pin mount 560, and a second end extends through an opening formed through the lower strut 520 to engage the dial 536 which rests upon an outer surface of the lower strut 520. A cover plate 66 may be included to cover at least part of the pin 538 located between the upper and lower struts 518, 520.

[165] Fig. 33 depicts rotation of the dial 536 which urges the pivoting of the lower strut 520 relative to the upper strut 518. This arrangement is advantageous in that the wearer can adjust the force exerted by the strut assembly on the trochanter via the trochanter support 514 to urge the femoral head into the hip socket. The dial 536 may include indicia, which would allow the wearer to have an understanding how much force to exert onto the hip joint.

[166] The wearer may in an initial fitting set the lower strut 520 so it pivots significantly away from the upper strut 518, and then rotate the dial so the lower strut 520 is drawn toward the upper strut 518 to exert more pressure on the trochanter. The

dial may be coupled to a gear system that provides mechanical advantage to enable easier adjustment and locking of the dial as it is adjusted.

[167] The trochanter support 514 is pivotally and rotatably secured to the inner surface of the upper strut 518 by a swivel 568 and hinge 530. This arrangement permits the trochanter support 514 to adjust to the specific anatomy of the wearer and to adapt to movement of the wearer's leg.

[168] A pressure adjustment mechanism 531 is secured to the upper strut 518 and preferably located between the pin 538 and the hinge 528. The pressure mechanism 531 is adapted to urge linear movement of the trochanter support 514 relative to the inner surface of the upper strut 518.

[169] The pressure mechanism 531 includes a dial 532 and a pin 534. The dial 532 is on the outer surface of the upper strut 518, and the pin 534 extends between the dial 532 and a pin mount 537 on or part of the swivel 568. The lower strut 520 may include a slot 539 enabling the pin 534 at least partly through when the trochanter support 514 is fully drawn toward the upper strut 518.

[170] As shown in Fig. 34, rotation of the dial 532 causes the trochanter support 514 to linearly travel relative to the inner surface of the upper strut 518. This allows for fine adjustment of the pressure of the trochanter support 514 without further adjusting the upper and lower struts 518, 520 relative to one another. The trochanter support 514 may include padding 562 to provide more compression as the trochanter support 514 is adjusted against the wearer.

[171] A cover 564 is used to cover both portions of the pressure mechanism 531 and the pivot mechanism 535 when they are not being used for adjustment. Portions of the dial 536 may be exposed from the cover 564 for quick adjustment of the trochanter support 514, whereas the pivot mechanism 535 is concealed.

[172] Referring to Fig. 35, the lower support 516 is adjustably secured to the lower strut 520 by a sleeve 542 engaging one of apertures 540 formed by the lower support 516. The apertures 540 are formed along the length of the lower strut 520, and the sleeve 542 defines an adjustment device 544 that engages one of the apertures 540. The adjustment device 544 includes a flexible tab 546 having a head 548 biased toward the lower strut to flexibly engage one of the apertures 540. The adjustment device 544 allows for sliding the lower support 516 along the second end of the lower

strut 520 to adjust the position of the lower support 516 to the length of the wearer's leg.

[173] The lower support 516 is rotatably and pivotally adjustably secured to the sleeve 542. A pivot mount 552 secures to the lower support 516 by a pivot pin 556 and a hinge 554 attaches to the lower support 516 via the pivot mount 552. A strap 550 secures to the lower support 516 to circumferentially secure to the lower leg of the wearer.

[174] The embodiments described may include means to allow for quick removal of the garment if the user desires its removal, such as using a restroom. A zipper may be provided to enable opening the opening of the garment to facilitate removal or as an opening for male users.

[175] The garment may include various sections including silicone on the inner surface to resist movement of the garment on the body of the user. These sections may include the waist portion of the garment and at the lower portion over the thigh. When added with the tension from the tensioning system, the silicone and the tension of the garment tightly secures the garment to the body of the user.

[176] The garment may be used in combination with various means for therapy including cold or hot therapy, such as at the trochanter pad, or various forms of electrotherapy including NMES, TENS, PEMF and heat therapy.

[177] The embodiments described provide compression, skin protection, sealing, load transfer (compression/rotation), and reduction in pelvis drop and stability. The garment provides compression for those users having superior or lateral osteoarthritis of the hip. Compression at the hip by applying force to the femoral head moves the point of contact, or may be placing a counter force on to the femur to reduce the load on the hip socket. Compression of the pelvis may also assist hip muscles to relax and reduce muscle pain.

[178] Sealing of the labrum is helpful by placing pressure on the greater trochanter by the trochanter pad and assisting the labrum to seal the internal pressure of the joint. The main function of the acetabular labrum improves hip joint stability by deepening the hip socket by providing it with extra structural support, and partially sealing the joint to create a negative intra-articular pressure which contracts any distractive or pulling-apart forces. The second function of the acetabular labrum increases joint

congruity. By placing pressure on the labrum, the femoral head may get pulled into the socket and moved away from the affected osteoarthritis area of the joint.

[179] The exorotation strap may provide pain relief when the hip joint is externally rotated. By rotating the femoral head, either internally or externally, sealing of the labrum may occur. Correcting the posture of the muscles placed in a more normal position may assist reduction of pelvis drop and reduce muscle pain. By stabilizing the hip, pain may be reduced since it is placed in a more correct position. Various embodiments of the garment may be formed from a slippery elastic material, such as a spandex, which assists in compressing against the body of the user and reduces the possibility of irritation. Referring to the embodiment of Fig. 36, features of the embodiments described herein may be combined in an orthopedic device 600 arranged to aid in hip arthroscopy procedures by distracting the hip joint to allow entry of the arthroscope. The orthopedic device may serve to alleviate pain arising from indications such as femoral acetabular impingement.

[180] The orthopedic device 600 includes a belt assembly 602 with tensioning device 608 that may be arranged similarly to the first and second belt members 202, 204, and tensioning devices 214 of the orthopedic device 200. The tensioning device 608 may be spread out so the upper tensioning devices adjust compression in the lumbar region while the lower tensioning devices apply pressure in the trochanter region. The lumbar compression system delivers active vertebral offloading and a better grip of patient's hips

[181] An exorotation strap 604 with a tensioning device 606 with may likewise be provided similarly to the exorotation strap 217 and the tensioning device 220. The exorotation strap 604 may secure to a lower strap 622 that may be similar to the lower strap 226. Alternatively, the exorotation strap 604 may strap to the lower wrap with a buckle that enables the user to open the buckle for removal or loosening of the exorotation strap. A known buckle that may be used is described in U.S. patent 7,198,610, granted on April 3, 2007.

[182] The orthopedic device 600 is preferably without a garment, but rather it includes a hip orthosis 610. The hip orthosis is secured to the belt assembly 602 by appropriate means such as a pocket 630 or other fastener means such as hook and loop, and to the lower wrap 622. The hip orthosis may be arranged similarly to the

hip orthosis described in U.S. application no. 13/528,032, filed on June 20, 2012, and published as U.S. patent application publication 2012/0323154 A1 on December 20, 2012. The hip orthosis may employ the features in U.S. application no. 12/353,555, filed on January 14, 2009 and published as U.S. patent application publication 2009/0124948 A1 on May 14, 2009, U.S. patent 8,172,779, granted on May 8, 2012, U.S. patent 7,597,672, granted on October 6, 2009, and U.S. patent 7,198,610, granted on April 3, 2007.

[183] In referring to Figs. 36 and 37 illustrate an embodiment of the hip orthosis 610, which incorporates some of the basic functions of the hip orthosis taught in part in U.S. patent 7,597,672. According to this embodiment, the hip orthosis 602 includes a hip plate 612 adapted to secure to the hip of the user and remain in place with the belt assembly 602. The orthosis includes a lower thigh cuff 620 adapted to secure to the thigh of the user and remain in place with the lower wrap 622.

[184] A spring rod 614 connects the hip plate 612 and the lower thigh cuff 620 to one another. A lower spring rod support 616 and an upper spring rod support 622 engage the spring rod 614. An thigh pad or shell 618 slidably engages and is carried by the spring rod 614. The thigh pad or shell 618 may or may not be arranged to rotated relative to the thigh of a user. The spring rod 614 is pivotally connected to the lower thigh cuff 620 at pivot connection 628. The lower thigh cuff 620 may be arranged for height adjustment such that it can slide up and down relative to the spring rod 614 and snap in place among a plurality of predetermined locations.

[185] As for the hip plate 612, the spring rod 614 has an end portion inserted within the hip plate 612, and slides side to side relative to the hip plate 612 with the motion restricted by restriction stops 626, and flexion and extension stops 624 limit movements of the hip plate 612 and spring rod 106 relative to one another. The flexion and extensions stops 624 and the restriction stops 626 are adjustable on the hip plate 102.

[186] The stops are preassembled for the right hip and range of motion of 0° extension to 70° flexion. If the hip orthosis is fitted for the left hip and the range of motion restriction is adjusted, the restriction stops and the flexion/extension stops can be placed in the correct location. Two restriction stops, one flexion stop and one extension stop, are arranged to restrict the range of motion. Guides may be provided

on the inside and outside portions of the hip plate for reference, however the resultant flexion and extension angle should be verified to assure that the correct is angle is set.

[187] If the desired angle is between 0° and 70° , the restriction stops are placed in two inner openings (closest to the spring rod). If the desired angle is between 60° and 90° , the restriction stops are placed in two outer openings (farthest from the spring rod). The flexion/extension stops are placed according to indicia on the inside and/or the outside of the hip plate.

[188] The various straps, wraps and tensioning devices may be trimmed to accommodate the various size profiles of users. Hook materials, buckles and other fastening devices may be removably secured to these various components to permit quick sizing changes. The straps may be oriented in different directions, such as the exorotation strap, to allow for modular placement of these straps to allow for extension or flexion control, and internal or external control. Various pads may be removably secured to frame elements, such as the trochanter pad that can have a cutout of inner foam for better fit and comfort around the trochanter.

Claims:

1. An orthopedic device (200), comprising:

a garment (216) having a hip region arranged to circumferentially extend over a hip region of a user;

characterized in further comprising first and second belt members (202, 204) secured to and extending generally from first and second sides of the garment (216) and at an anterior side of the garment (216), the first and second belt members (202, 204) arranged to secure to one another and tension over the anterior side of the garment (216);

an exorotation strap (217) extending from a medial or lateral side of the orthopedic device at the lowermost orthopedic device of the garment (216) and extending obliquely by spiraling over a thigh region to a lateral or medial side over an posterior or anterior side and toward the uppermost portion of the orthopedic device, the exorotation strap (217) arranged to extend over a hip region of a user, the exorotation strap (217) having a lower end anchoring to the garment (216) and an upper end connecting to the posterior compression unit.

2. The orthopedic device of claim 1, characterized in further a posterior compression system (229) having first and second tensioning devices (214a, 214b, 214c, 214d) secured to and arranged to extend from opposed sides of a posterior region of the garment (216) toward the anterior region of the garment (216), the posterior compression system (229) arranged to produce compression over the posterior side of the garment (216).

3. The orthopedic device of claim 2, characterized in that the posterior compression system (229) has first and second tensioning sets (242a, 242b, 242c, 242d) cooperating with the first and second tensioning devices (214a, 214b, 214c, 214d), respectively, the first and second tensioning sets (242a, 242b, 242c, 242d) secured to the garment (216) at first and second joints (244), respectively, located on opposed

sides of the garment (216) and oriented to extend toward another toward the posterior side of the garment (216).

4. The orthopedic device of claim 3, characterized in that the first and second tensioning sets (242a, 242b, 242c, 242d) are arranged to travel toward one another upon tensioning of the first and second tensioning devices (214a, 214b, 214c, 214d), and counteract tension exerted by the first and second belt members (202, 204).
5. The orthopedic device of claims 3 or 4, characterized in that the first and second belt members (202, 204) are secured along the first and second joints (244), respectively.
6. The orthopedic device of any one of claims 2-5, characterized in that the posterior compression system (229) is arranged to extend over a posterior pelvic region of a user.
7. The orthopedic device of any one of claims 2-6, characterized in that the first and second tensioning devices (214a, 214b, 214c, 214d) are arranged to extend over and secure to the first and second belt members (202, 204).
8. The orthopedic device of any one of the preceding claims, characterized in that the first and second belt members (202, 204) have a greatest height at first and second joints (244) whereat they secure to the garment (216), and generally taper in height toward the anterior side of an uppermost portion of the garment (216).
9. The orthopedic device of any one of the preceding claims, characterized in that the first and second belt members (202, 204) have a plurality of trim sections (207) bordered by trim lines for severing a section of an end portion of the first and second belt members (202, 204).
10. The orthopedic device of any one of the preceding claims, characterized in that the garment (216) includes an elastic portion (240) formed from a textile and configured to extend from a waist region at an uppermost portion of the garment (216) to a knee of a user at the lowermost portion of the garment (216).

11. The orthopedic device of any one of the preceding claims, characterized in further comprising a substantially inelastic lateral portion (238) extending along the elastic portion of the garment (216) generally from the uppermost portion to the lowermost portion of the garment (216) on a lateral side of the garment (216).

12. The orthopedic device of any one of the preceding claims, characterized in further comprising a tensionable lower wrap (226) arranged to extend near a knee of a user, the lower wrap (226) is secured to and extends over the garment (216) at or near a lowermost region.

13. The orthopedic device of claim 12, characterized in further comprising an elastic band (213) at a lowermost region of the garment (216), the elastic band (213) including a frictional interface defined on an inner surface of the orthopedic device for engaging skin of a user to prevent migration of the garment on a user, the lower wrap (226) extending over the elastic band (213) over an outer surface of the garment (216).

14. The orthopedic device of any one of the preceding claims, characterized in that the exorotation strap (217) is adjustable in length between the lower and upper ends thereof.

15. The orthopedic device of claim 2, characterized in that an upper end of the exorotation strap (217) anchors to the posterior compression system (229).

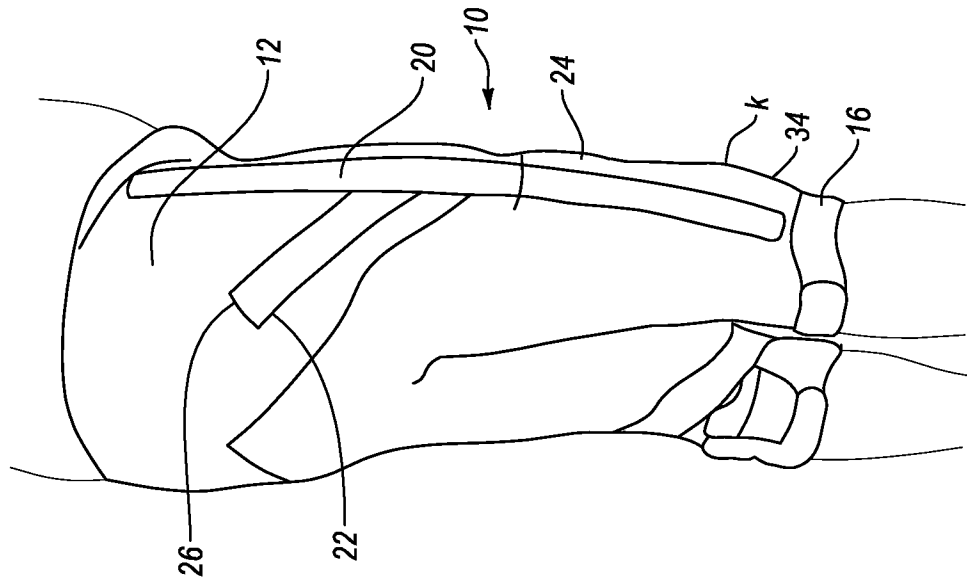

FIG. 2

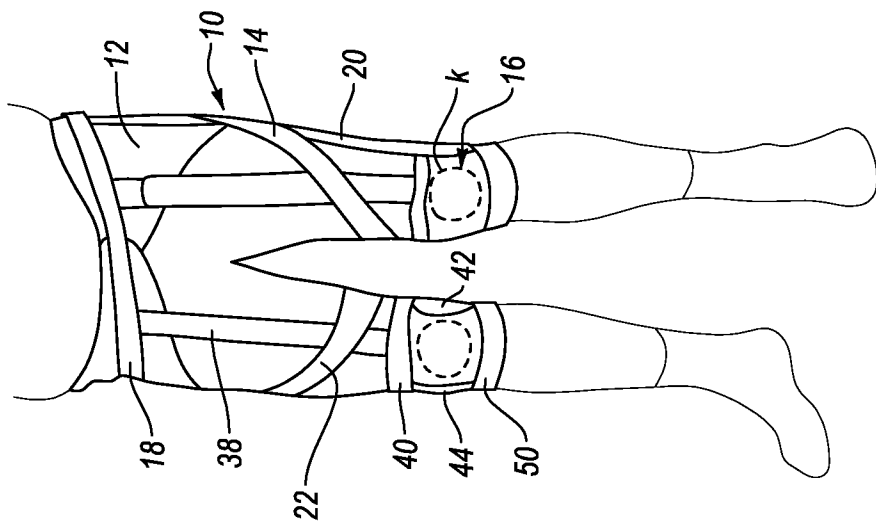

FIG. 1

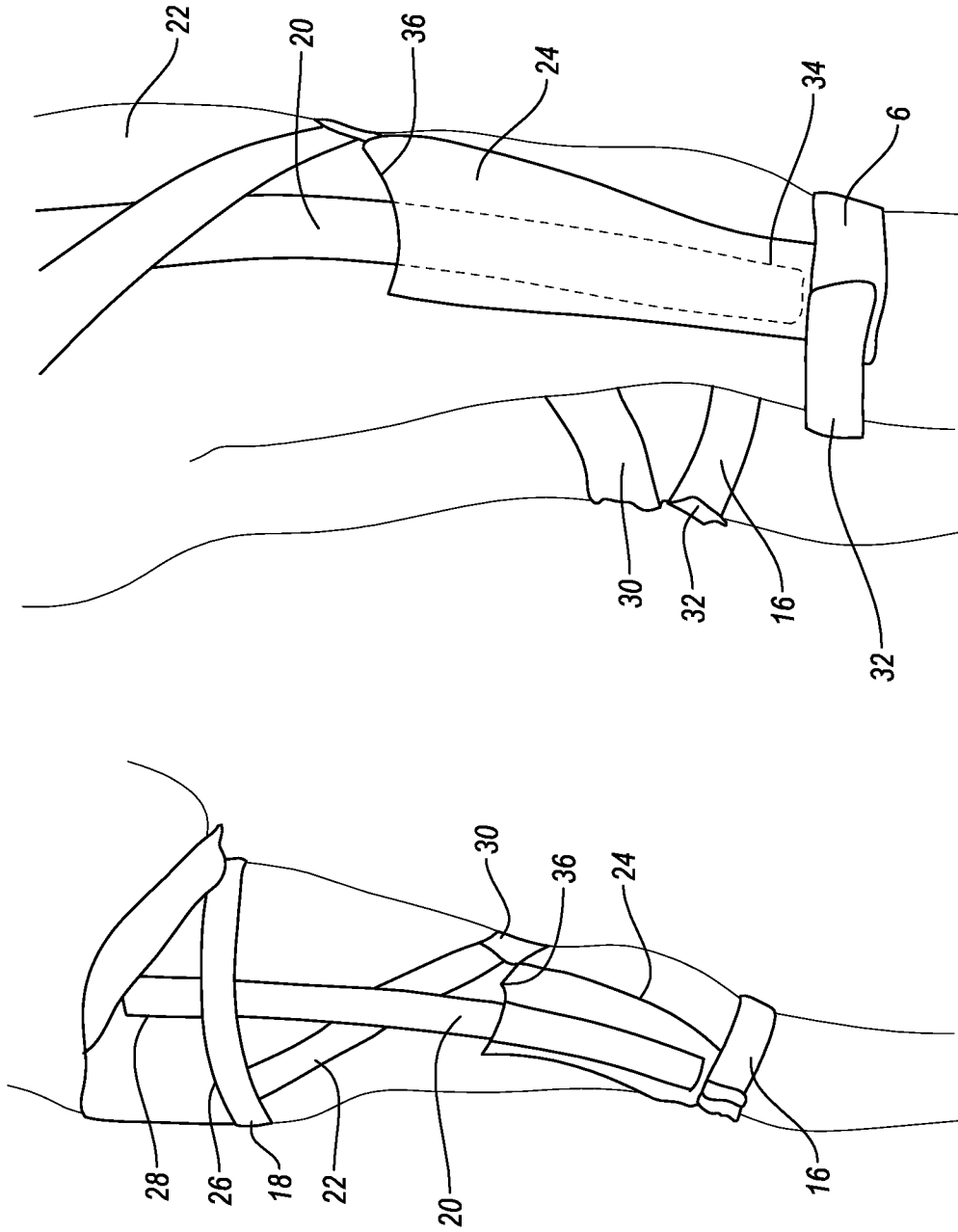

FIG. 3

FIG. 4

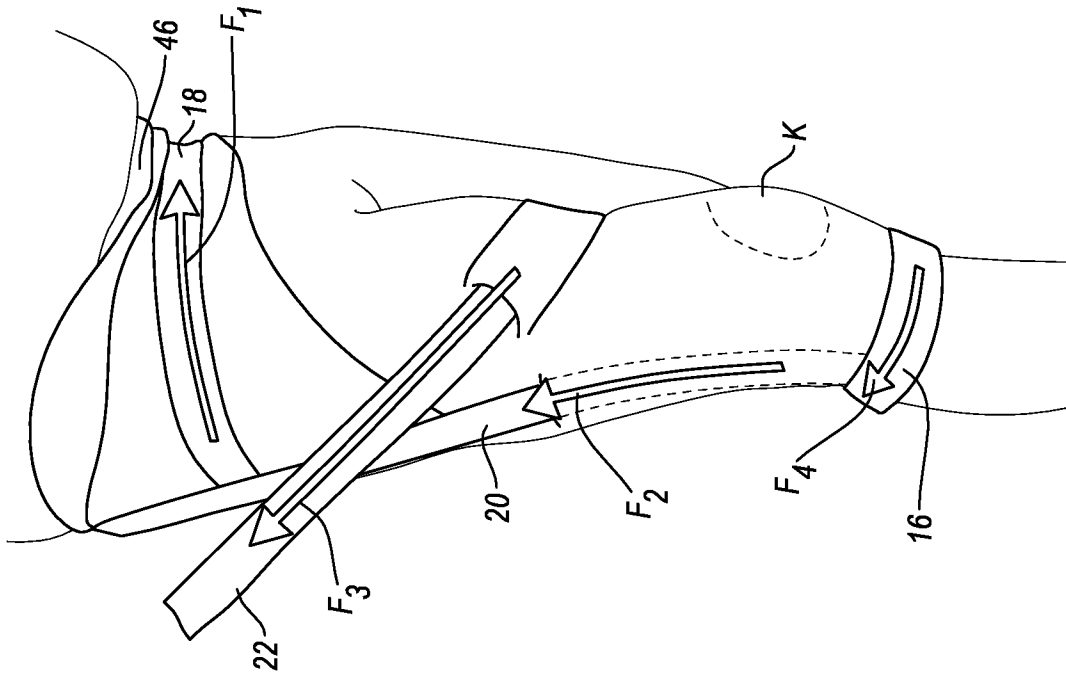

FIG. 6

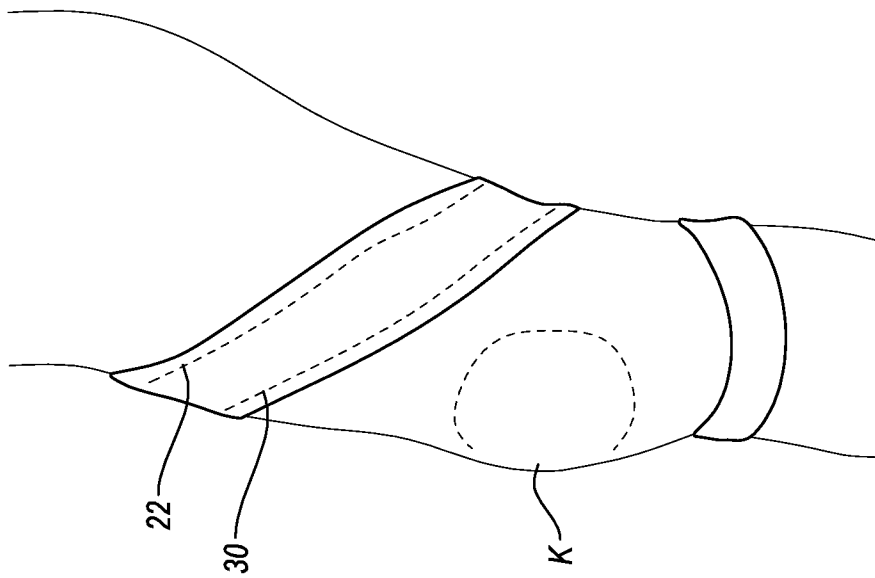

FIG. 5

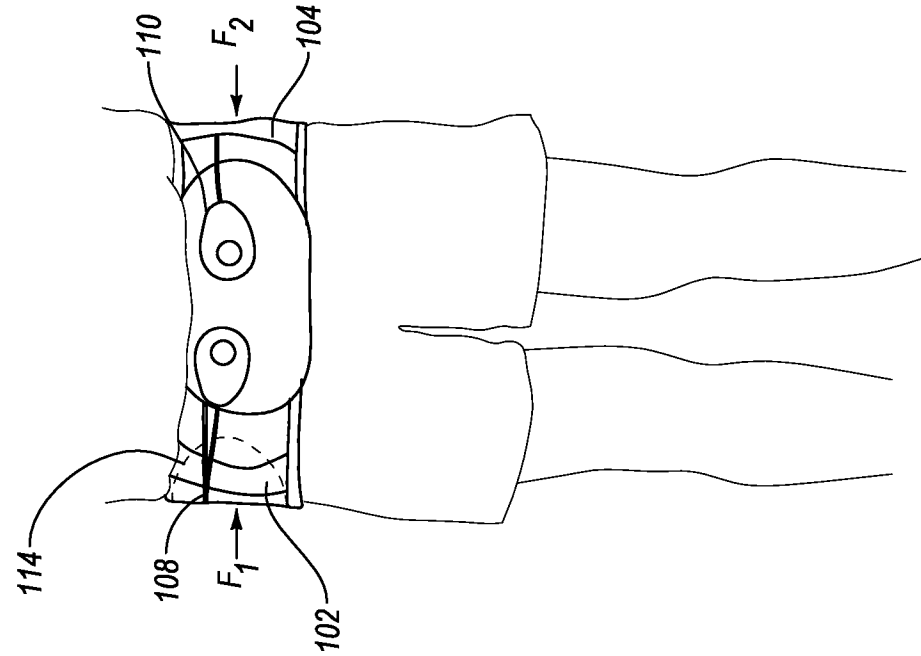

FIG. 7B

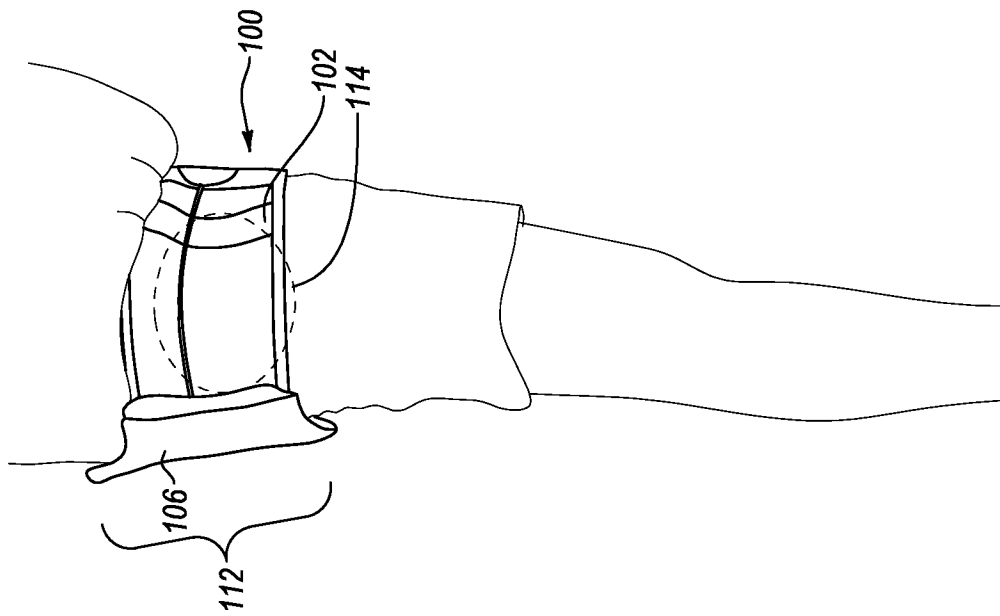

FIG. 7A

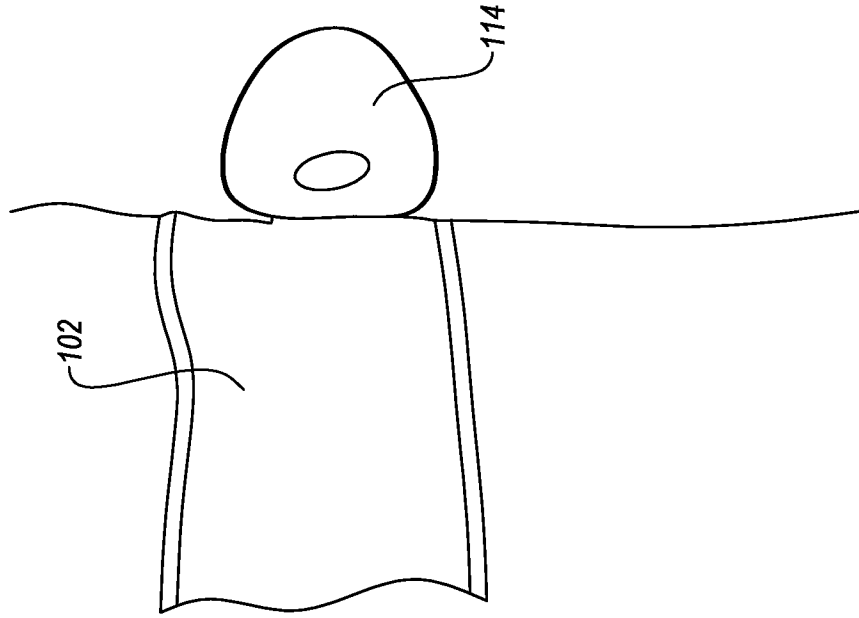

FIG. 8

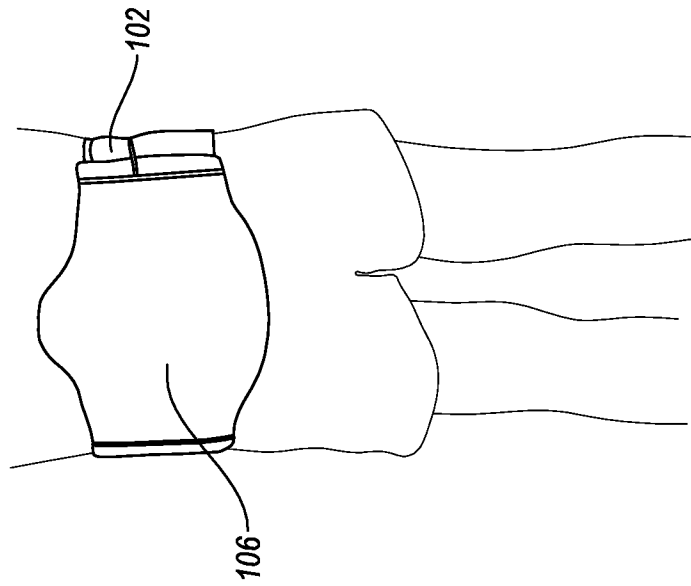

FIG. 7C

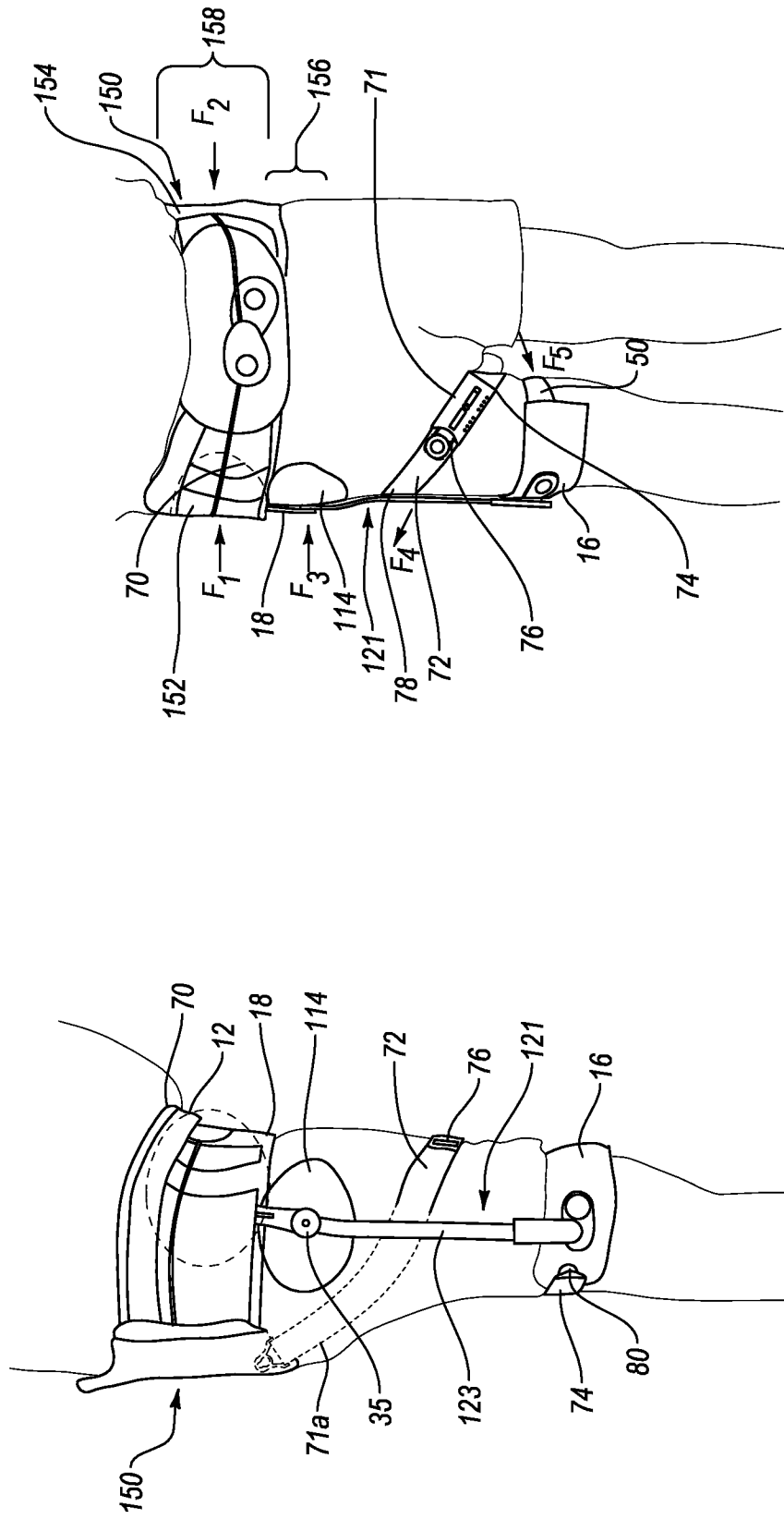

FIG. 9B

FIG. 9A

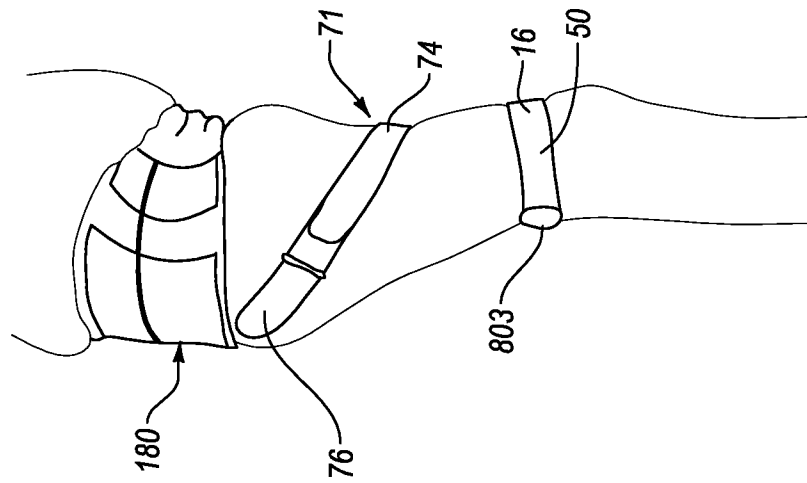

FIG. 10A

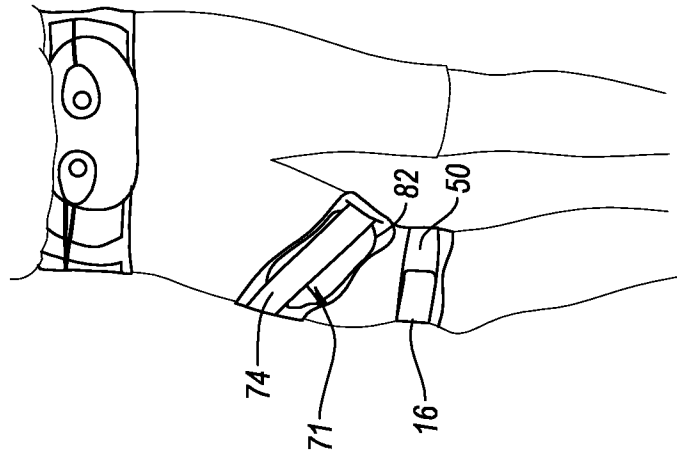

FIG. 10B

8 / 24

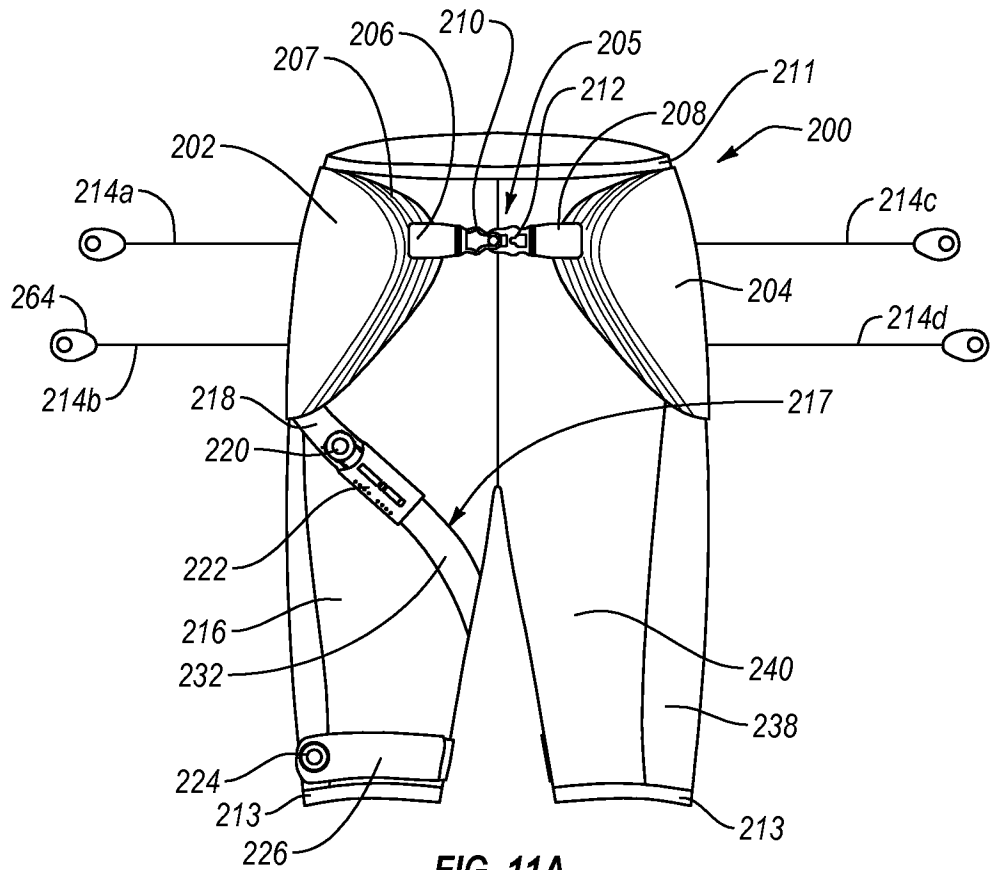

FIG. 11A

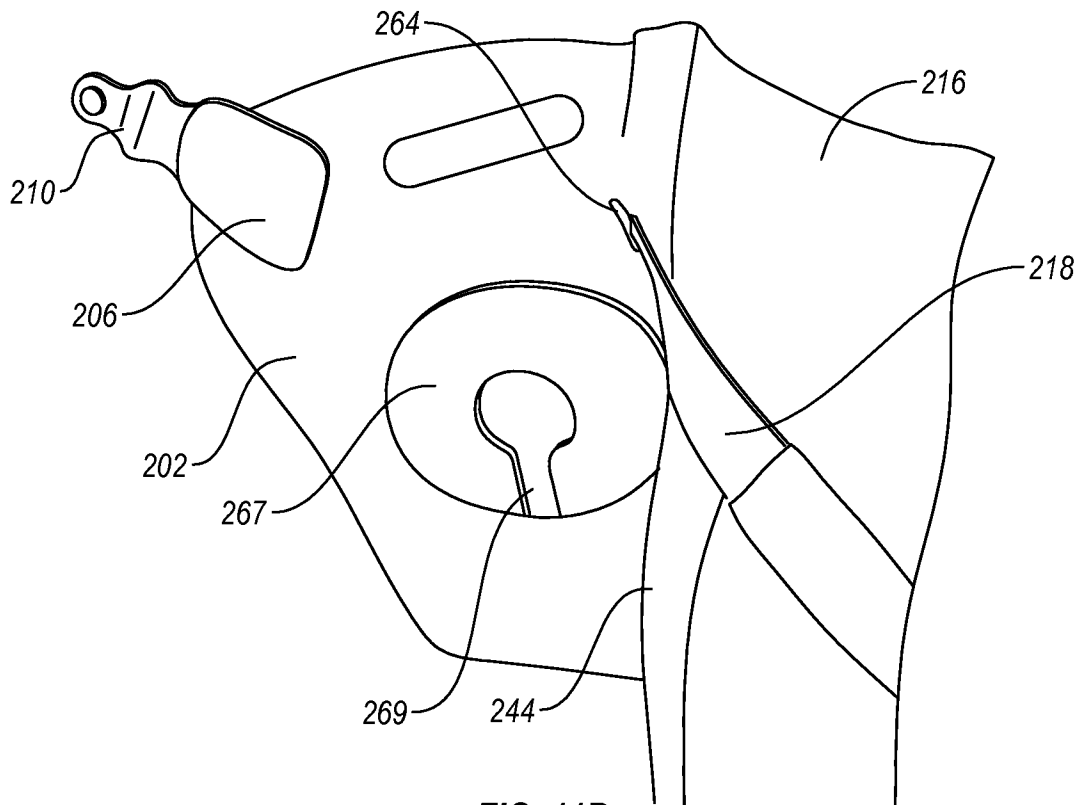

FIG. 11B

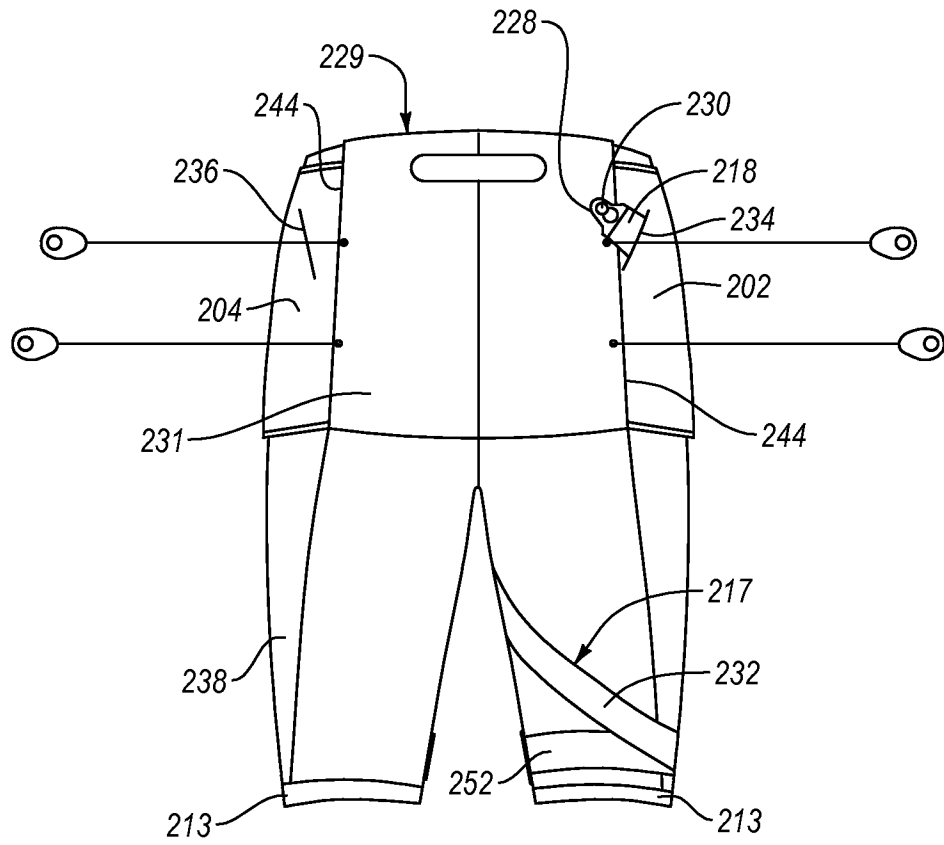

FIG. 12

10 / 24

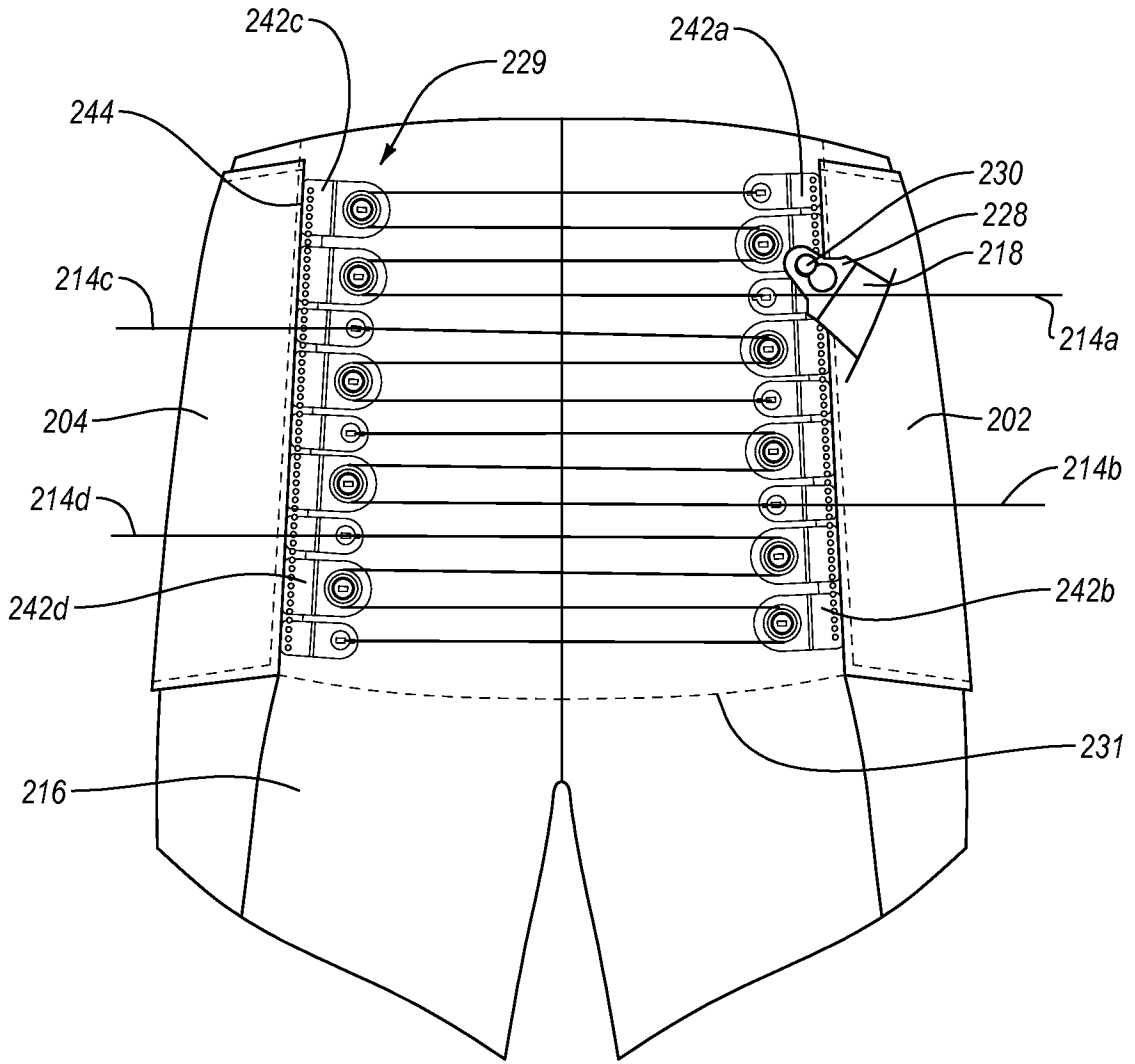

FIG. 13

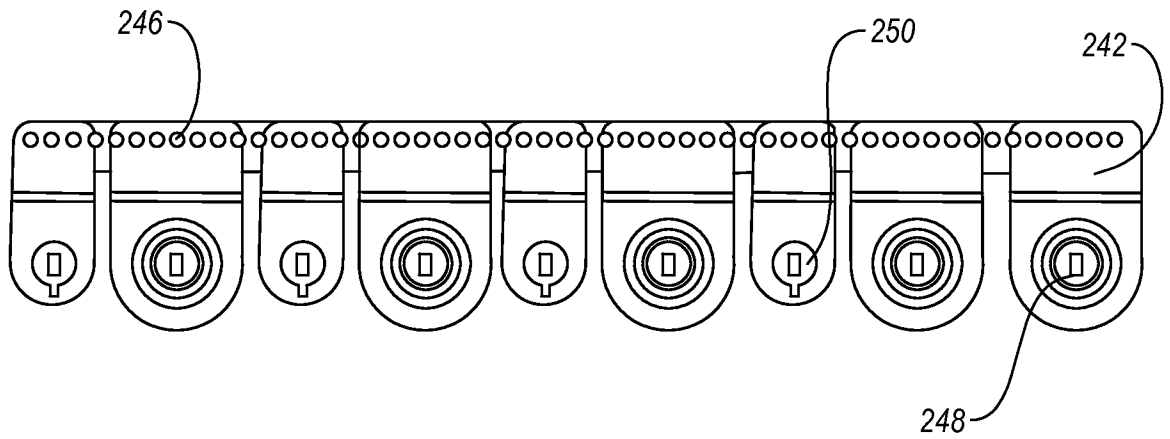
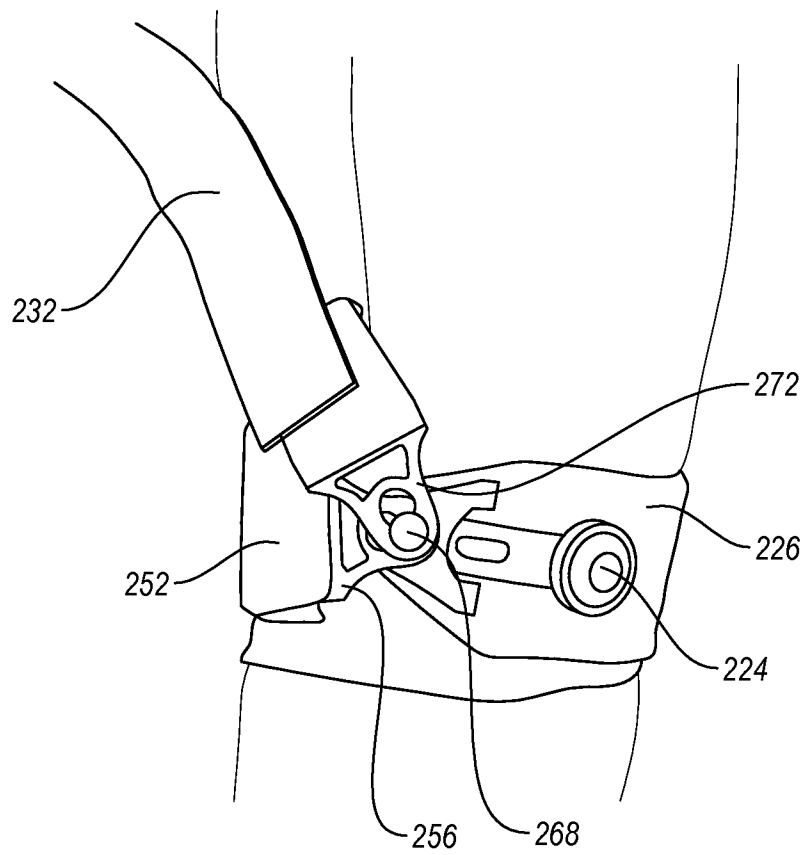
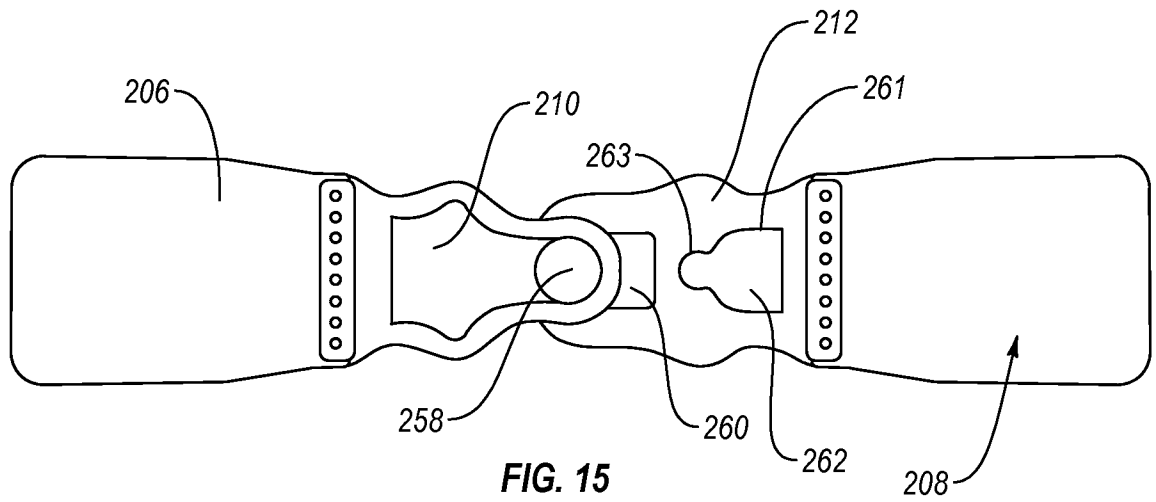

FIG. 14

11 / 24



12 / 24

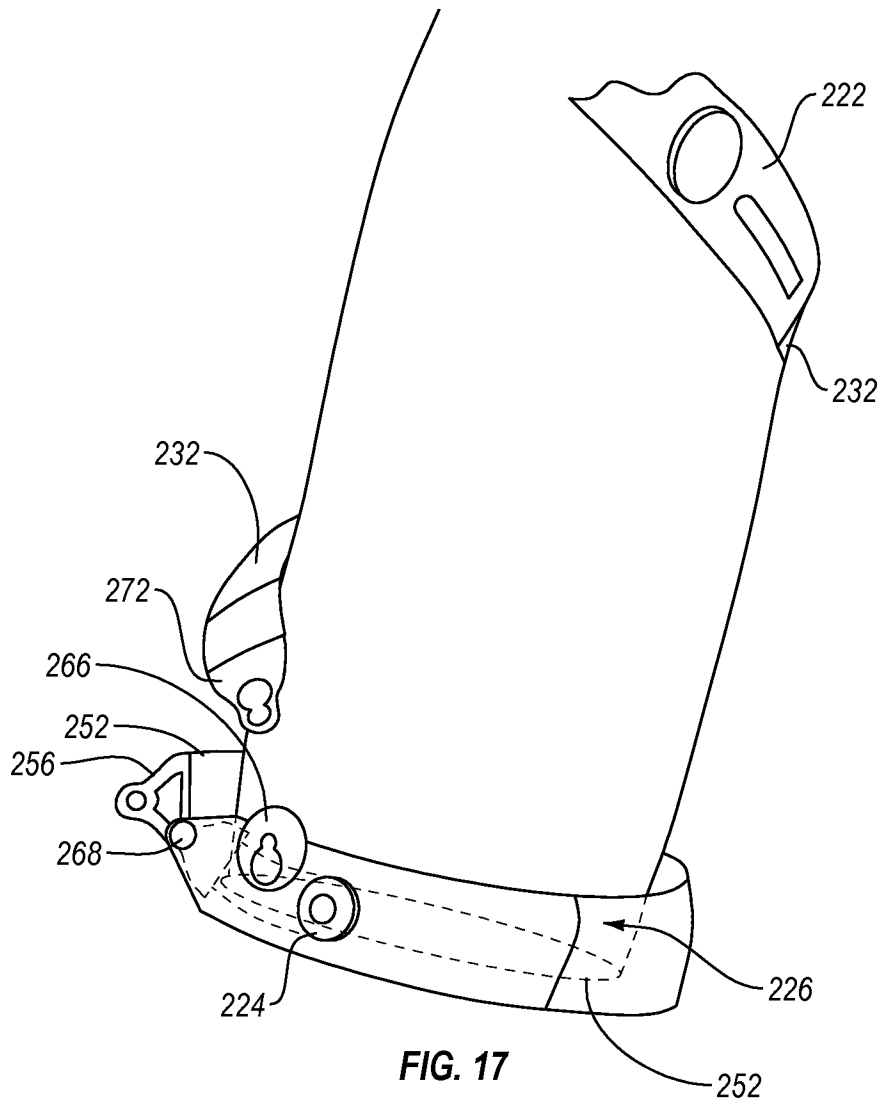

FIG. 17

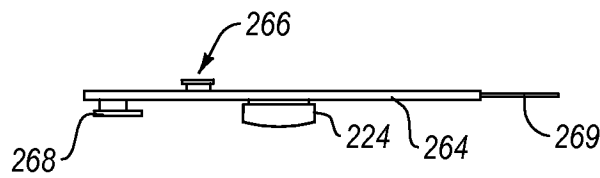

FIG. 18A

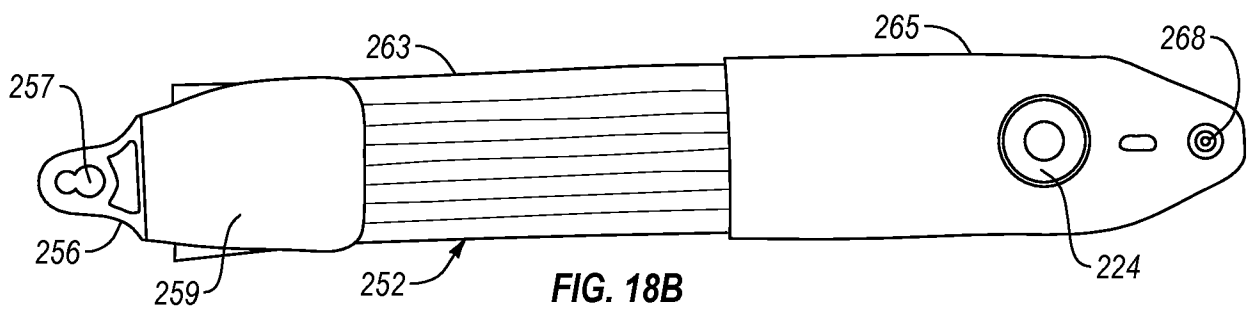

FIG. 18B

13 / 24

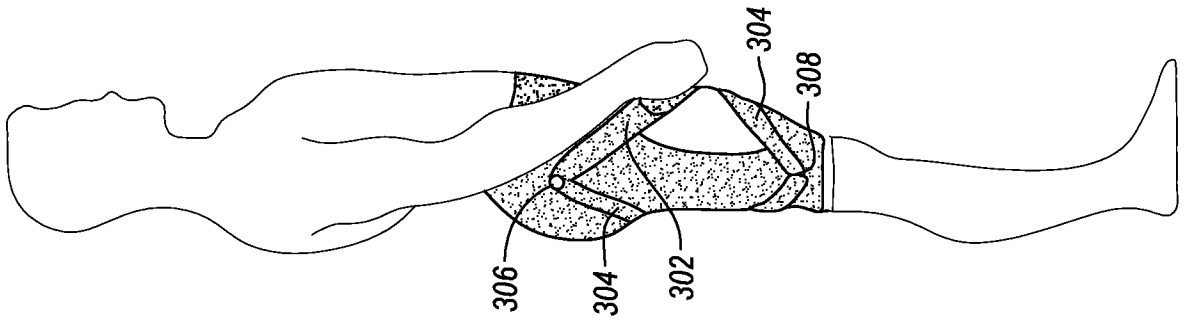

FIG. 22

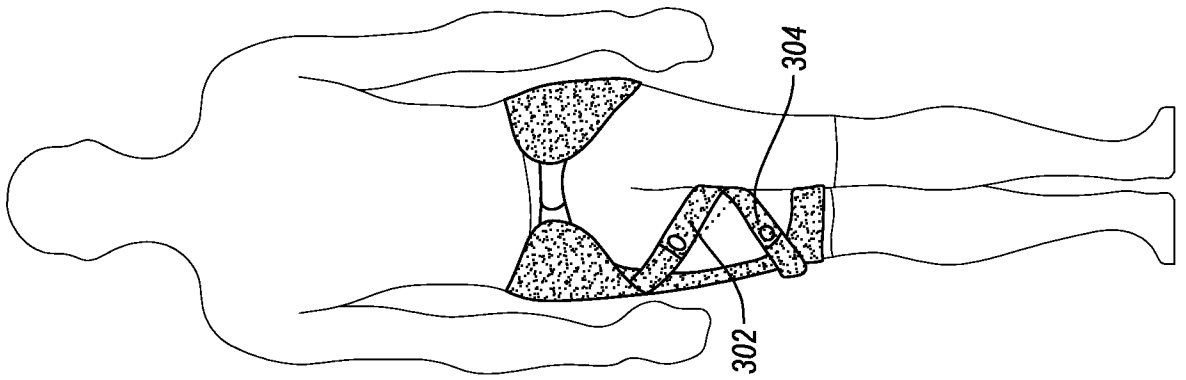

FIG. 21

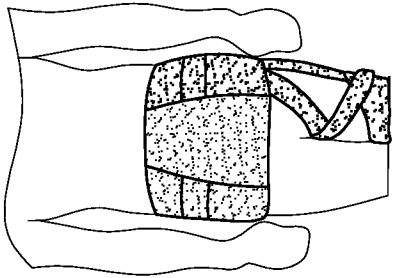

FIG. 20

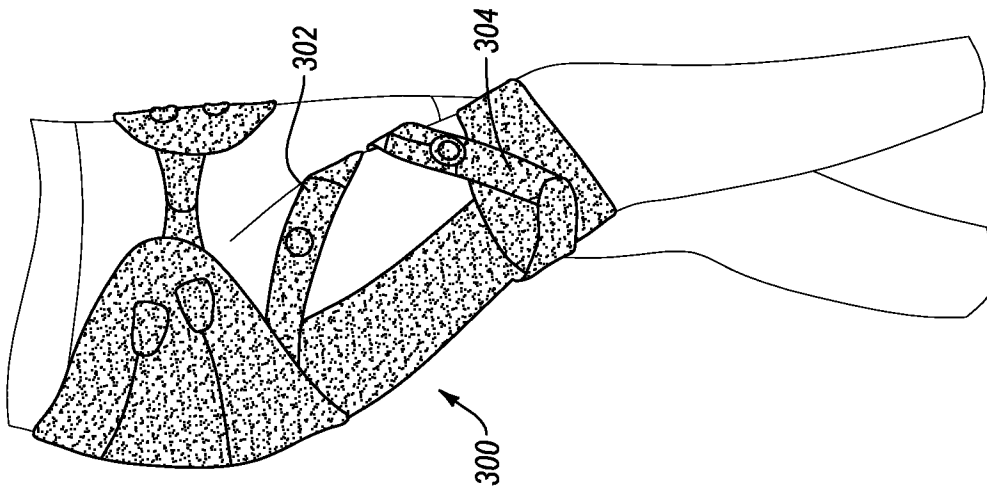

FIG. 19

14 / 24

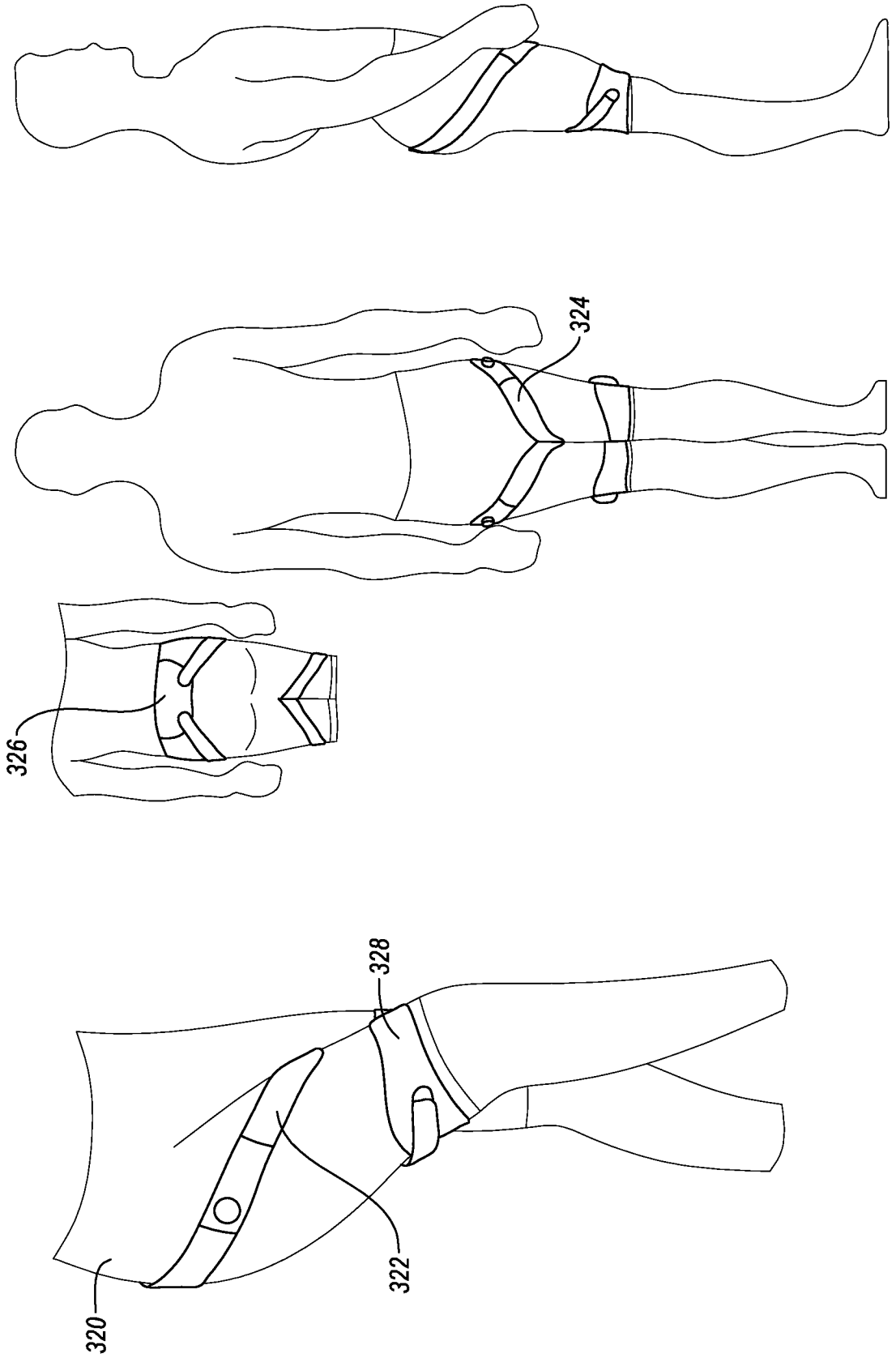

FIG. 23

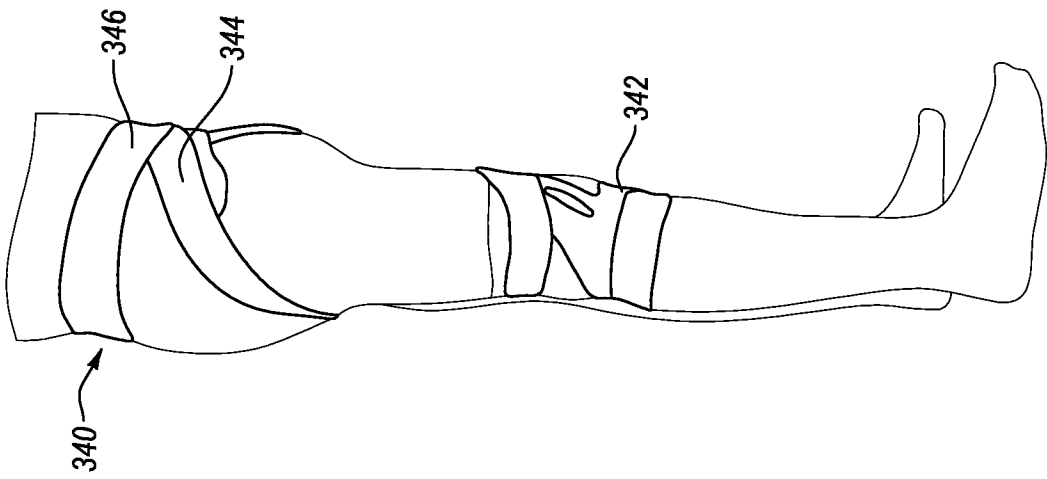
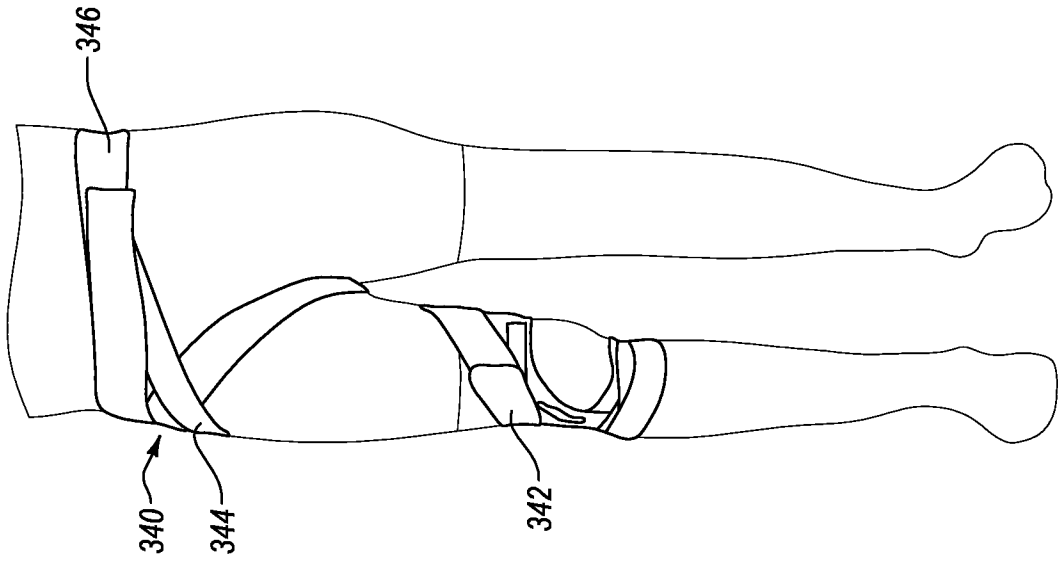

FIG. 24

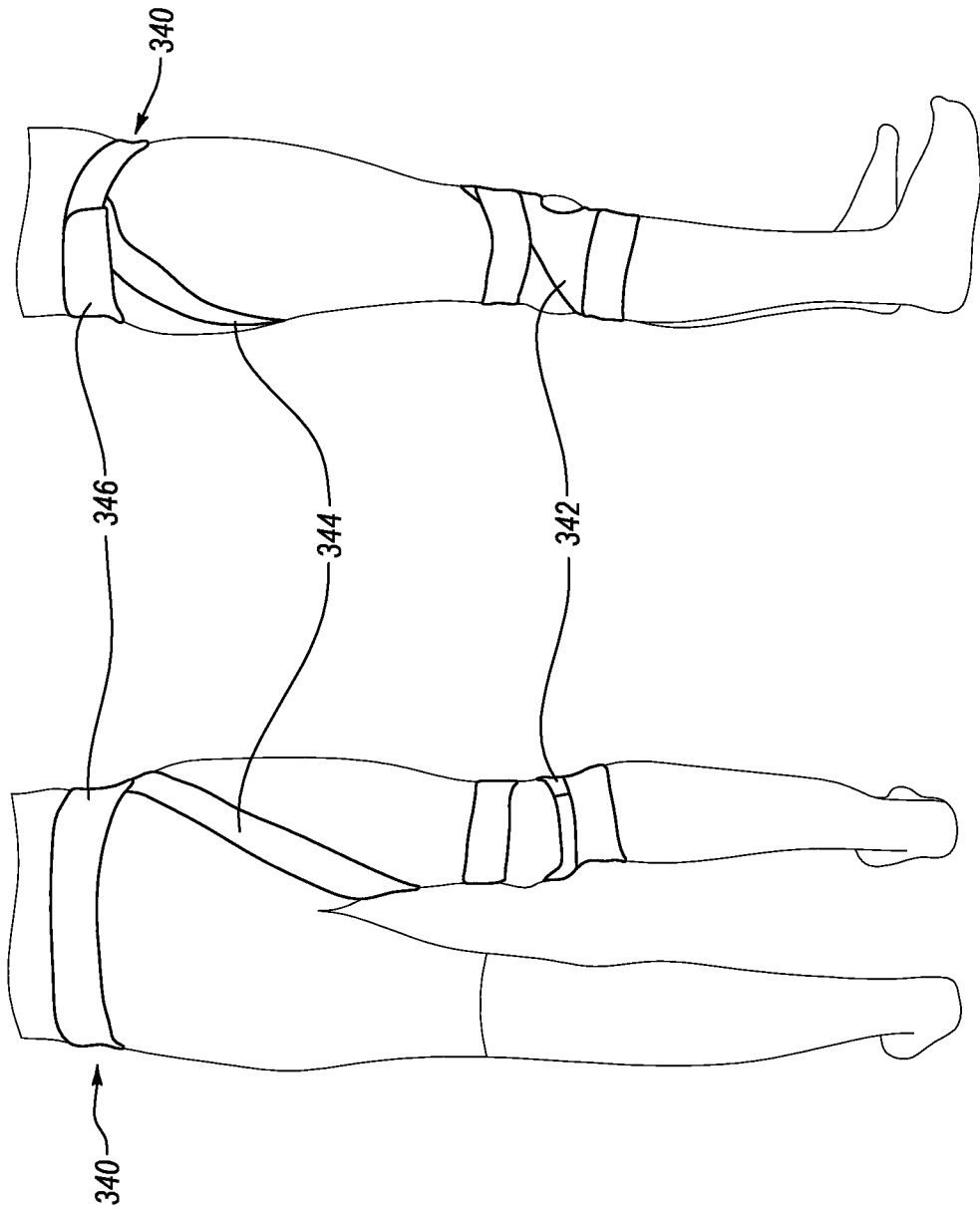

FIG. 25

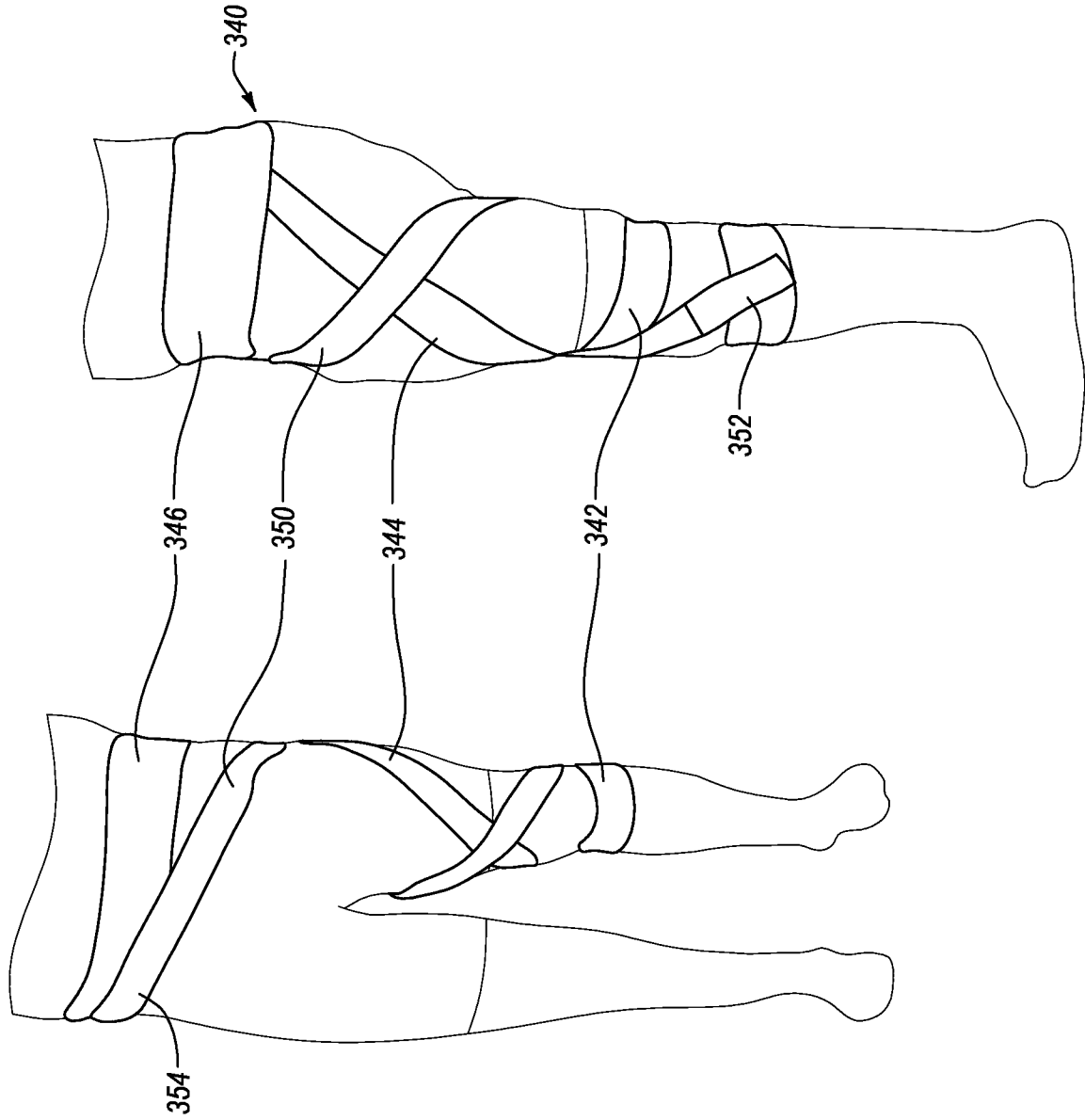
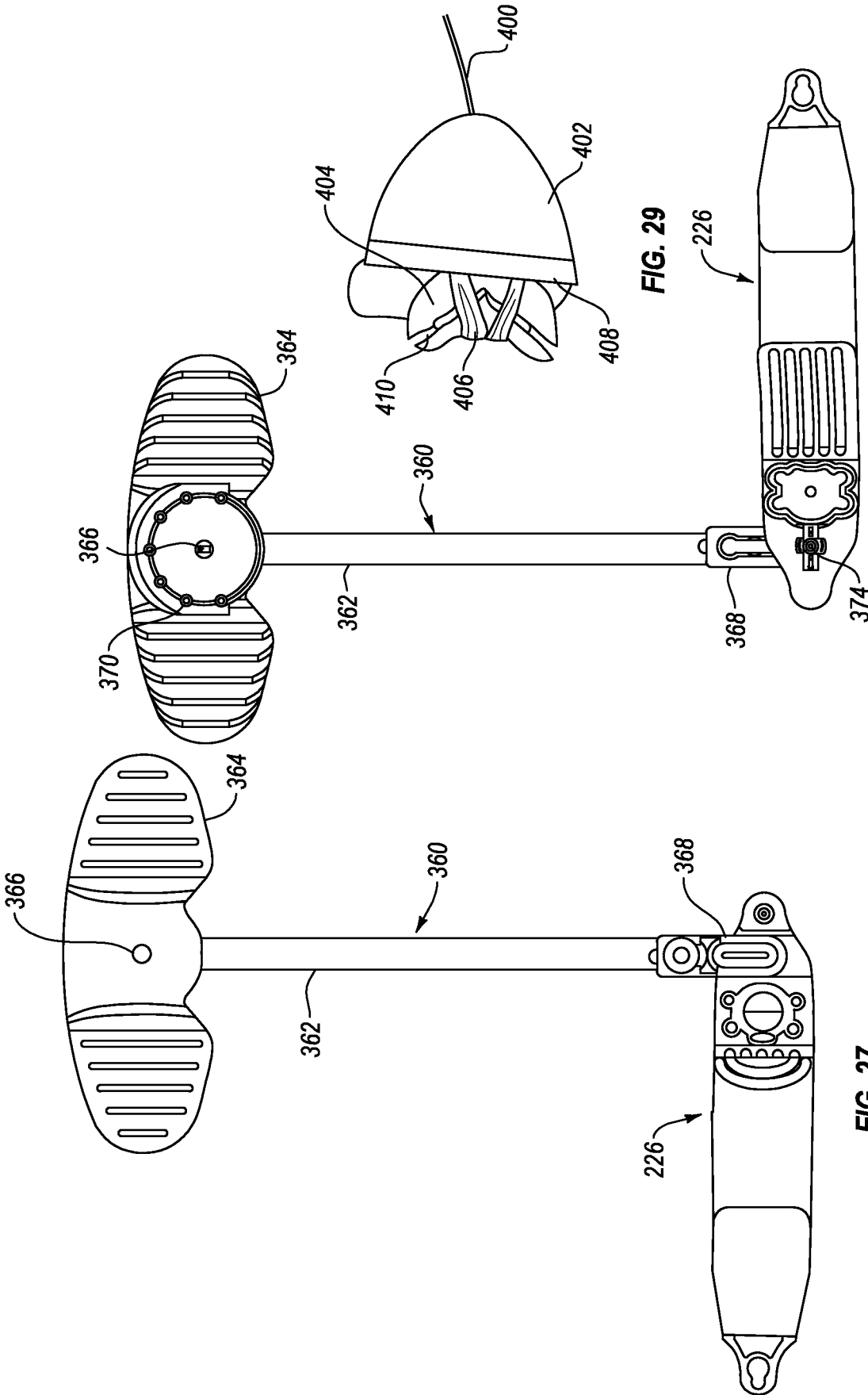

FIG. 26



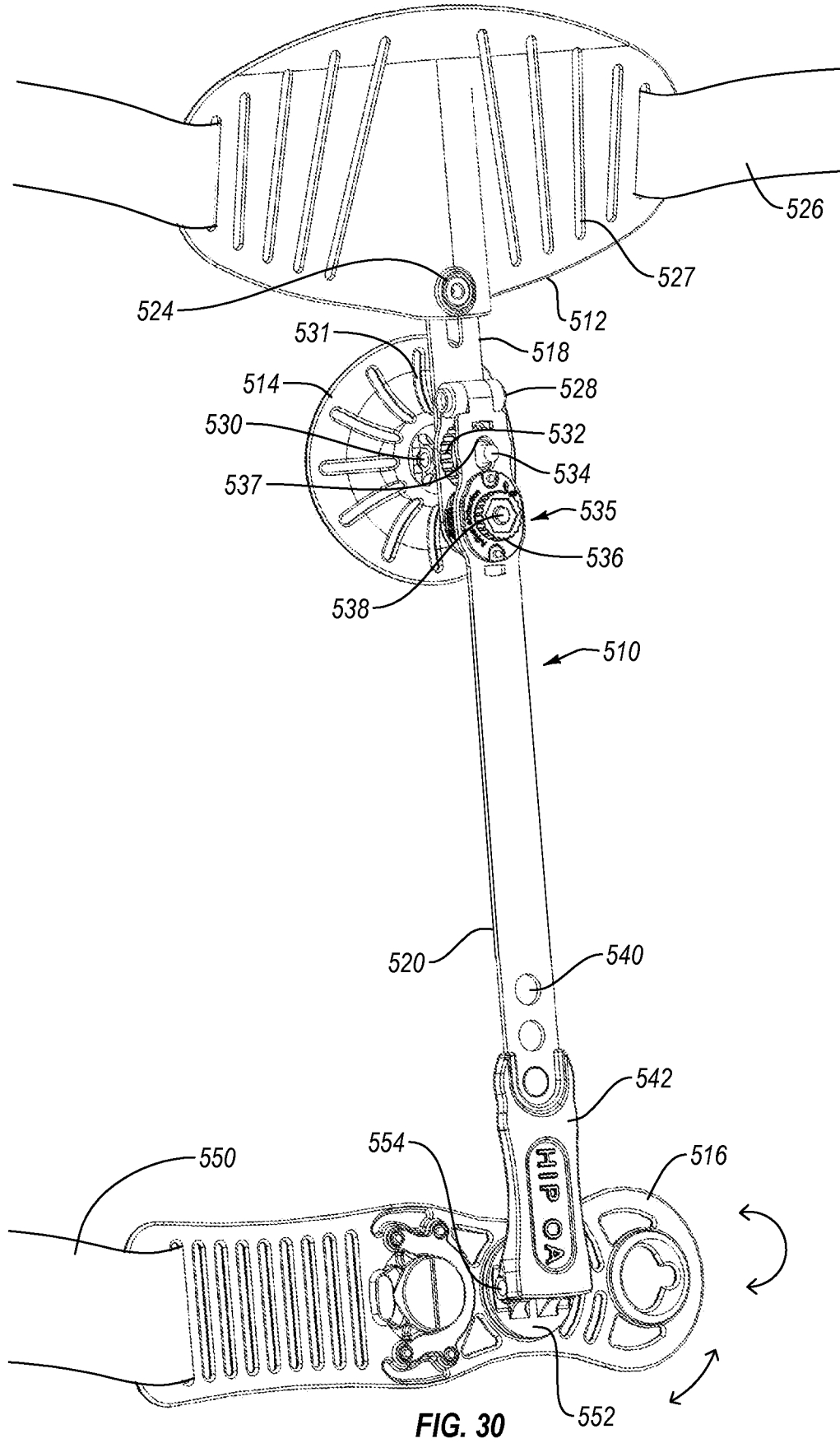

FIG. 30

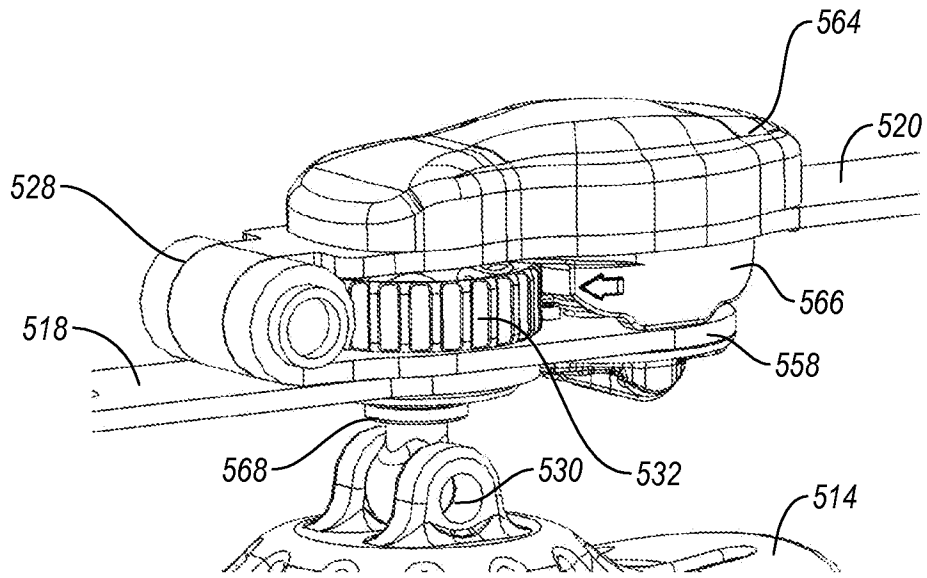

FIG. 31a

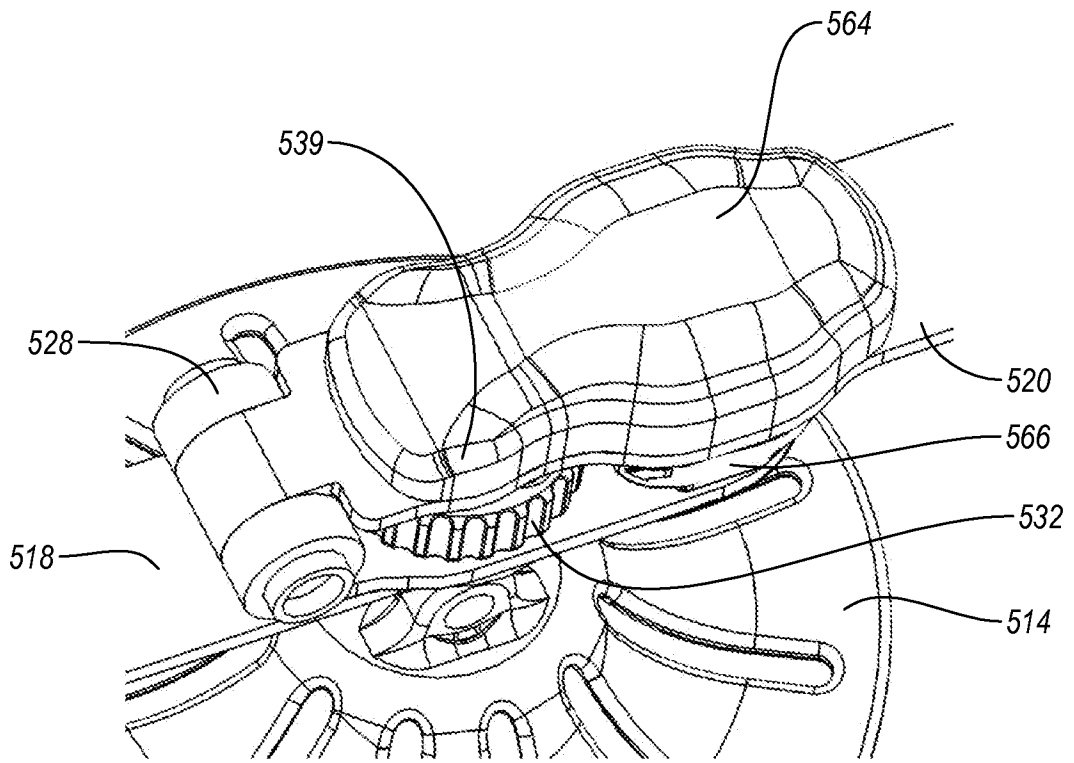

FIG. 31b

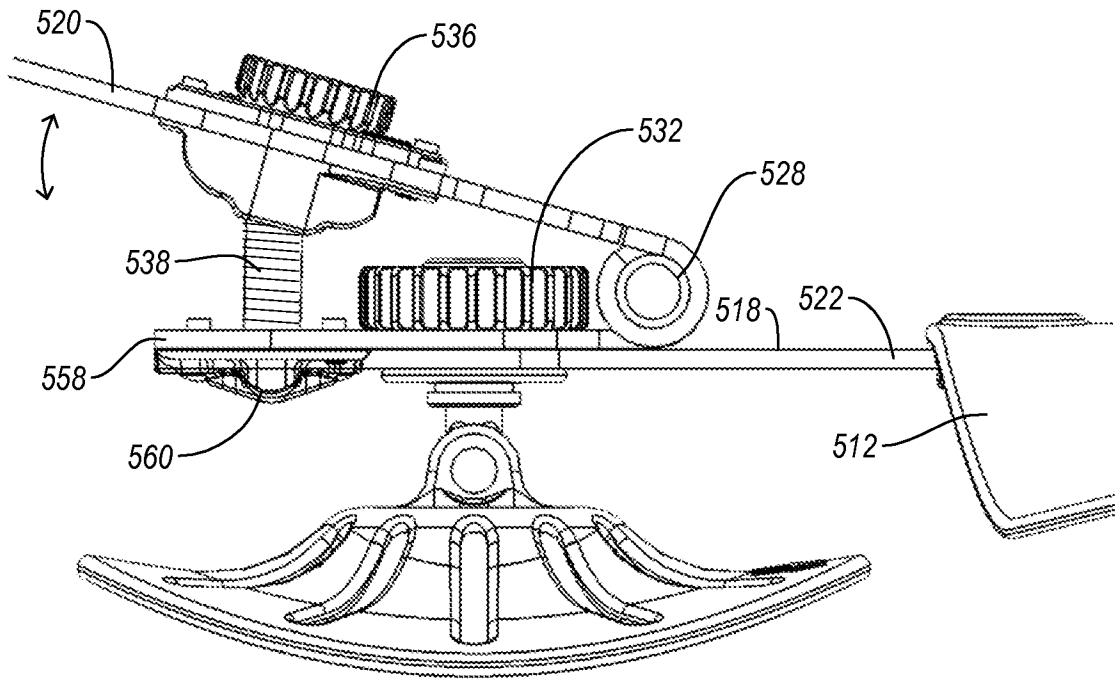

FIG. 33

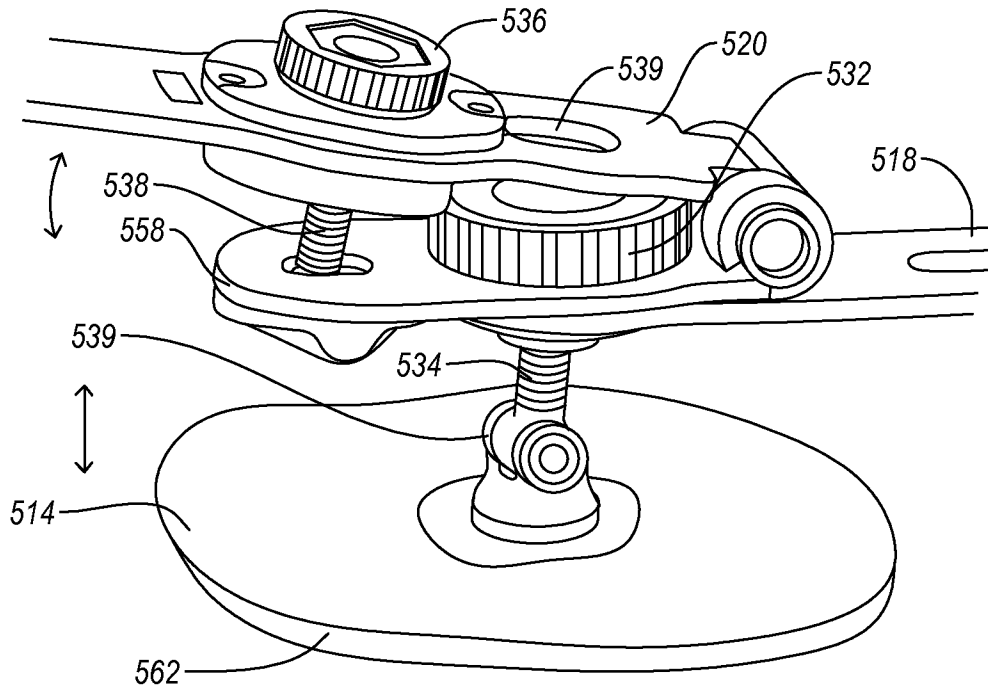

FIG. 34

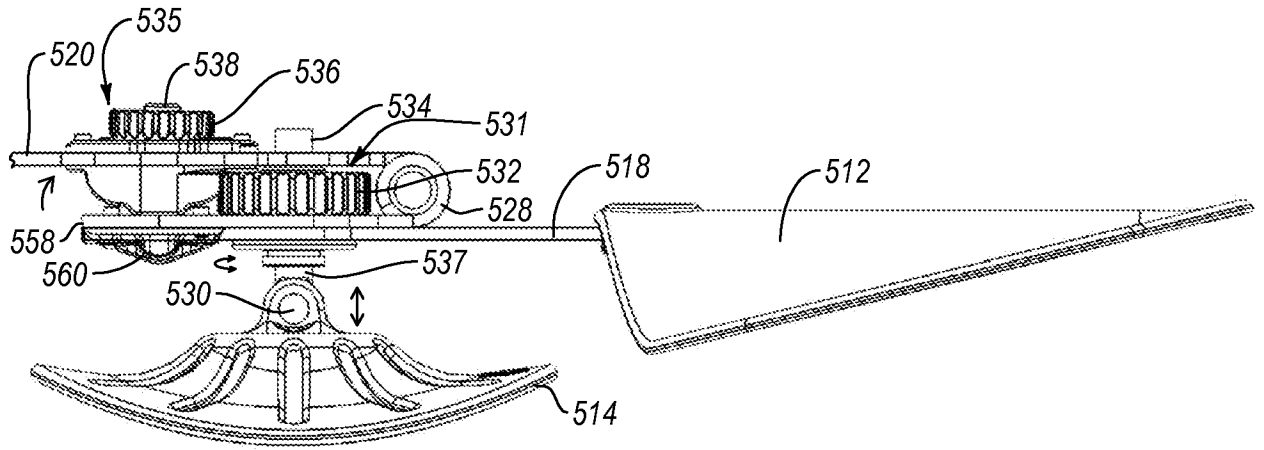
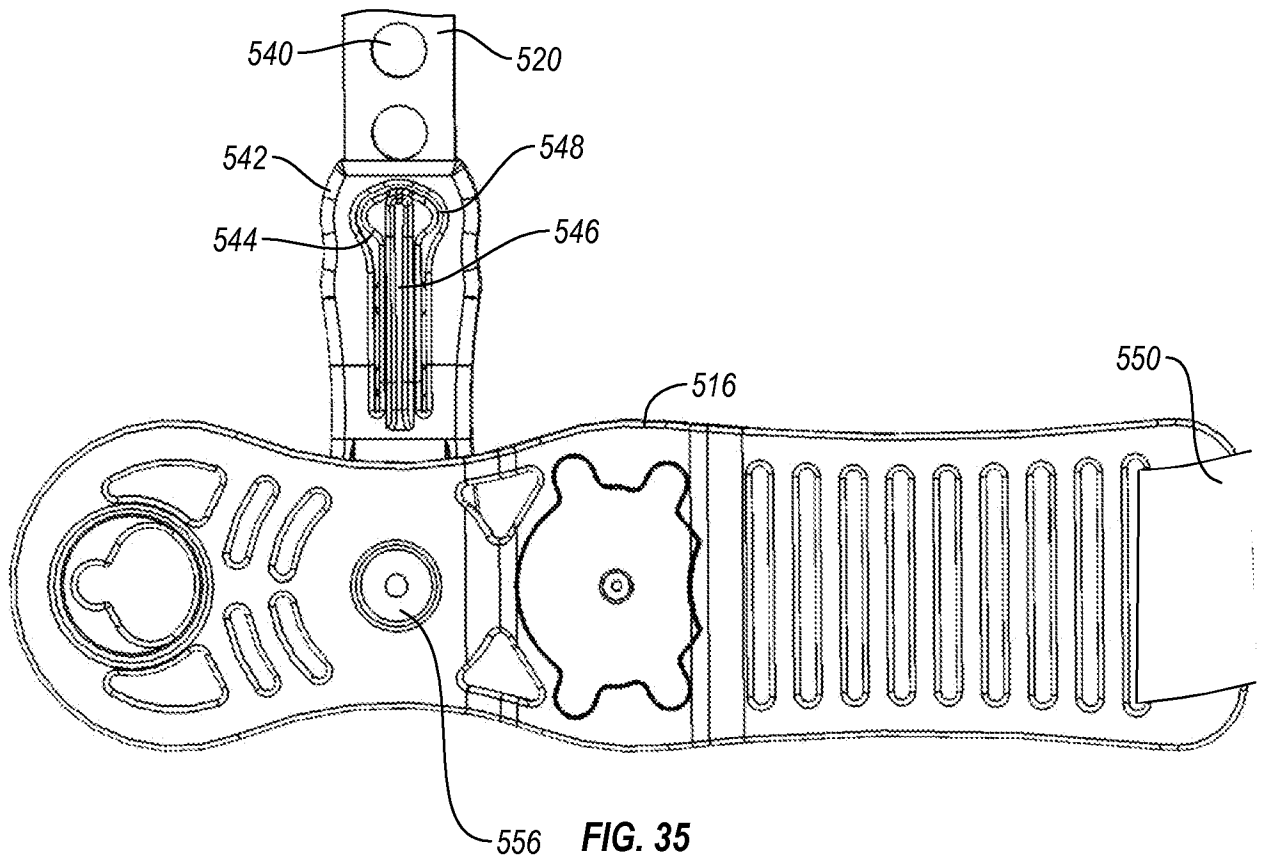

FIG. 32



556 FIG. 35

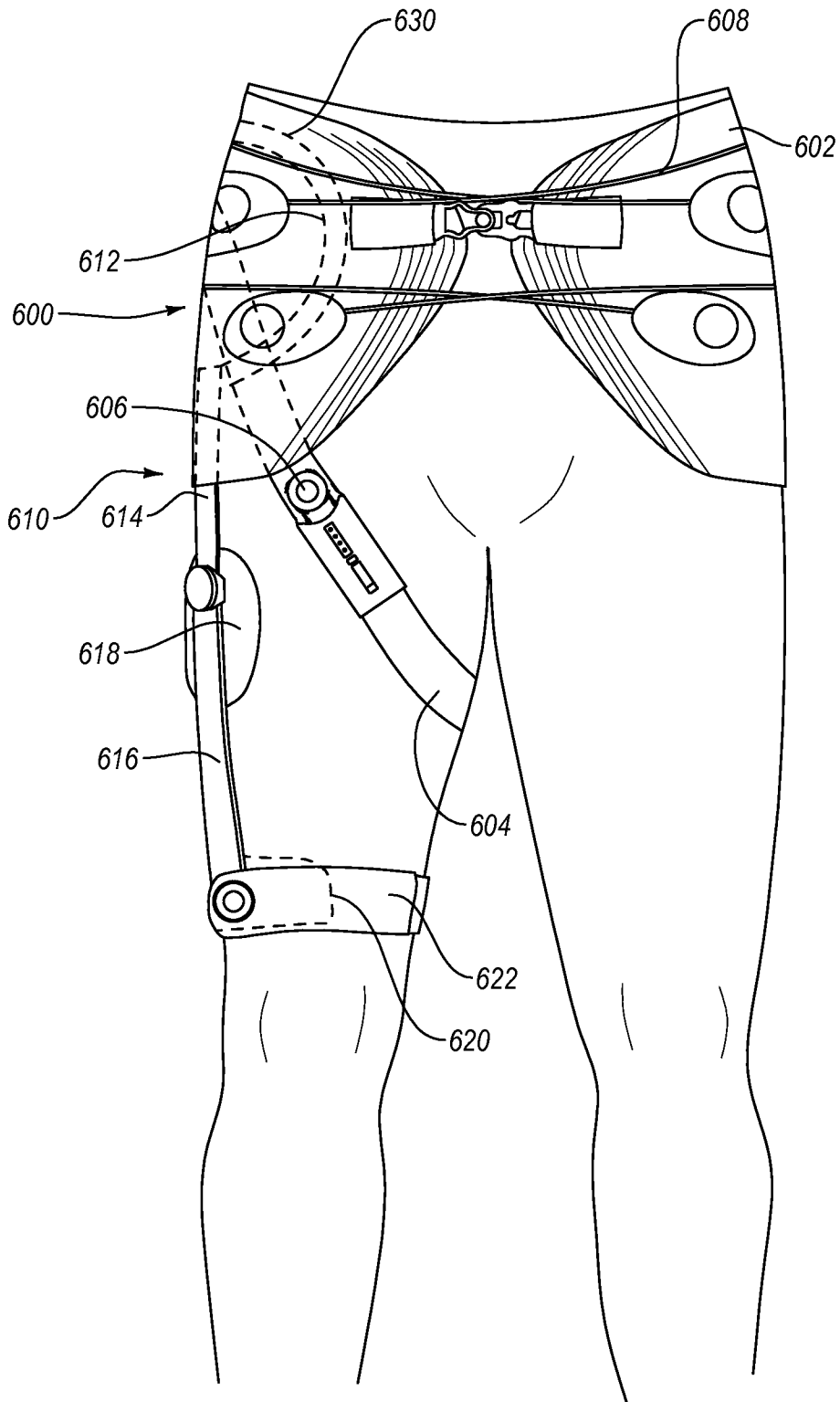

FIG. 36

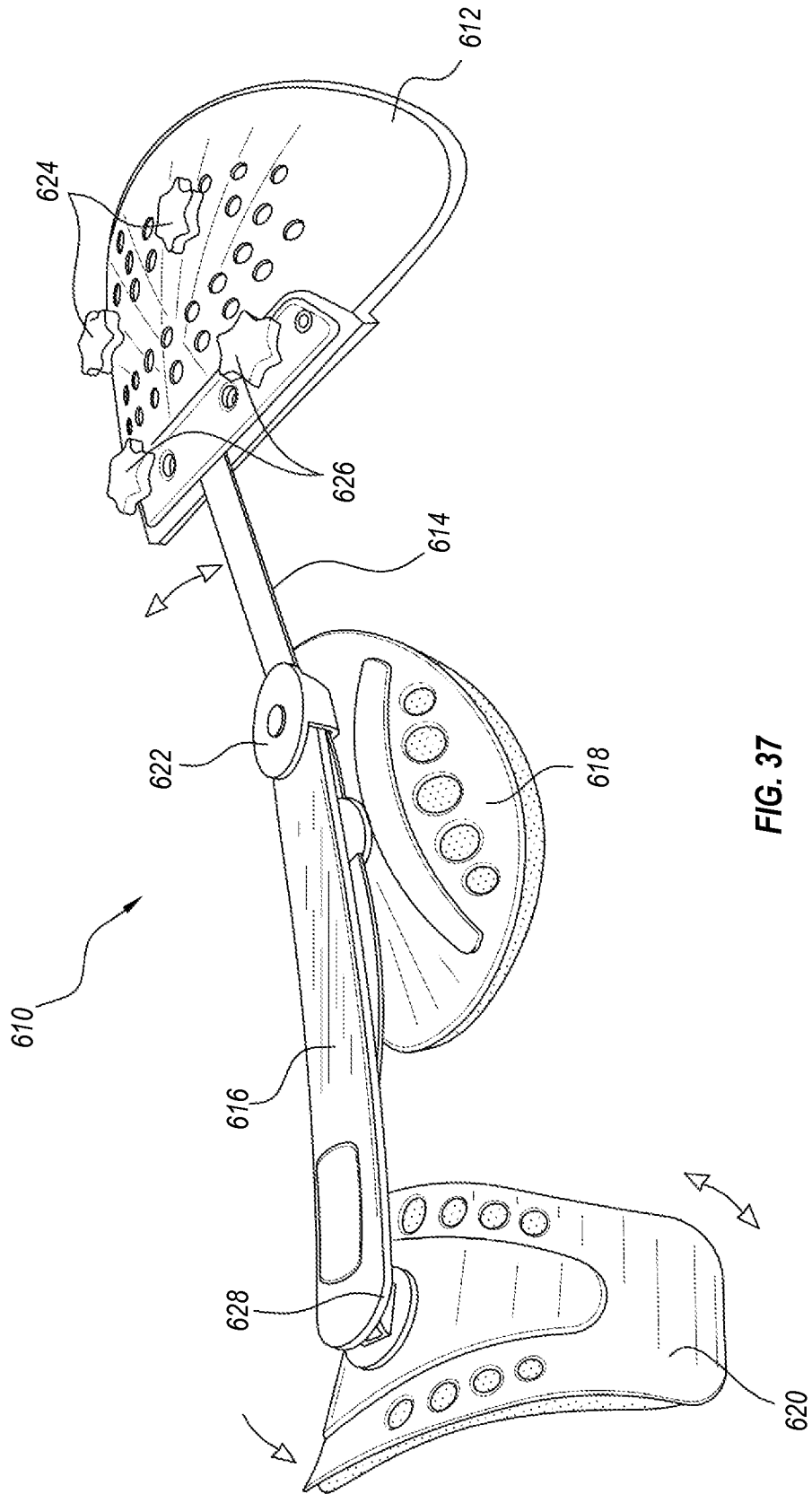

FIG. 37

INTERNATIONAL SEARCH REPORT

International application No
PCT/US2014/012860

A. CLASSIFICATION OF SUBJECT MATTER
INV. A61F5/01
ADD.
According to International Patent Classification (IPC) or to both national classification and IPC

B. FIELDS SEARCHED
Minimum documentation searched (classification system followed by classification symbols)
A61F
Documentation searched other than minimum documentation to the extent that such documents are included in the fields searched

Electronic data base consulted during the international search (name of data base and, where practicable, search terms used)
EPO-Internal, WPI Data

C. DOCUMENTS CONSIDERED TO BE RELEVANT		
Category*	Citation of document, with indication, where appropriate, of the relevant passages	Relevant to claim No.
X	US 5 201 074 A (DICKER TIMOTHY P [US]) 13 April 1993 (1993-04-13)	1
A	abstract; figures 10-13 column 6, lines 3-43 column 6, line 62 - column 7, line 7 -----	2-15
X	EP 1 342 423 A1 (WACOAL CORP [JP]) 10 September 2003 (2003-09-10)	1
A	abstract; figures 10-12, 19-26, 52-57 paragraphs [0010], [0016], [0023], [0024], [0027] - [0033], [0072], [0080], [0087], [0088], [0093] -----	2-15
A	DE 20 2009 004817 U1 (HANS PETER GBR [DE]) 30 September 2010 (2010-09-30) abstract; figures -----	1-15
	-/--	

Further documents are listed in the continuation of Box C.

See patent family annex.

* Special categories of cited documents :

- "A" document defining the general state of the art which is not considered to be of particular relevance
- "E" earlier application or patent but published on or after the international filing date
- "L" document which may throw doubts on priority claim(s) or which is cited to establish the publication date of another citation or other special reason (as specified)
- "O" document referring to an oral disclosure, use, exhibition or other means
- "P" document published prior to the international filing date but later than the priority date claimed

"T" later document published after the international filing date or priority date and not in conflict with the application but cited to understand the principle or theory underlying the invention

"X" document of particular relevance; the claimed invention cannot be considered novel or cannot be considered to involve an inventive step when the document is taken alone

"Y" document of particular relevance; the claimed invention cannot be considered to involve an inventive step when the document is combined with one or more other such documents, such combination being obvious to a person skilled in the art

"&" document member of the same patent family

Date of the actual completion of the international search 8 April 2014	Date of mailing of the international search report 17/04/2014
Name and mailing address of the ISA/ European Patent Office, P.B. 5818 Patentlaan 2 NL - 2280 HV Rijswijk Tel. (+31-70) 340-2040, Fax: (+31-70) 340-3016	Authorized officer Lager, Johan

INTERNATIONAL SEARCH REPORT

International application No
PCT/US2014/012860

C(Continuation). DOCUMENTS CONSIDERED TO BE RELEVANT		
Category*	Citation of document, with indication, where appropriate, of the relevant passages	Relevant to claim No.
A	US 2004/116260 A1 (DRENNAN DENIS [US] DRENNAN DENIS BURKE [US]) 17 June 2004 (2004-06-17) abstract; figures -----	1-15

INTERNATIONAL SEARCH REPORT

Information on patent family members

International application No

PCT/US2014/012860

Patent document cited in search report	Publication date	Patent family member(s)	Publication date
US 5201074	A	13-04-1993	NONE

EP 1342423	A1	10-09-2003	AT 355761 T 15-03-2007
		AU 1736201 A	24-06-2002
		CN 1461190 A	10-12-2003
		DE 60033856 T2	20-12-2007
		EP 1342423 A1	10-09-2003
		HK 1060835 A1	22-12-2006
		KR 20030060103 A	12-07-2003
		US 2003028952 A1	13-02-2003
		WO 0247501 A1	20-06-2002

DE 202009004817	U1	30-09-2010	NONE

US 2004116260	A1	17-06-2004	NONE
