



New Mix Design Method for Hot-Mix Cold-Laid Mixtures

Technical Report 0-7153-R1

Cooperative Research Program

TEXAS A&M TRANSPORTATION INSTITUTE
COLLEGE STATION, TEXAS

sponsored by the
Federal Highway Administration and the
Texas Department of Transportation
<https://tti.tamu.edu/documents/0-7153-R1.pdf>

1. Report No. FHWA/TX-24/0-7153-R1		2. Government Accession No.		3. Recipient's Catalog No.	
4. Title and Subtitle NEW MIX DESIGN METHOD FOR HOT-MIX COLD-LAID MIXTURES				5. Report Date Published: June 2024	
				6. Performing Organization Code	
7. Author(s) Kin Ming Chan, Fujie Zhou, and Cindy Estakhri				8. Performing Organization Report No. Report 0-7153-R1	
9. Performing Organization Name and Address Texas A&M Transportation Institute The Texas A&M University System College Station, Texas 77843-3135				10. Work Unit No. (TRAIS)	
				11. Contract or Grant No. Project 0-7153	
12. Sponsoring Agency Name and Address Texas Department of Transportation Research and Technology Implementation Office 125 E. 11 th Street Austin, Texas 78701-2483				13. Type of Report and Period Covered Technical Report: 9/1/2022–11/30/2023	
				14. Sponsoring Agency Code	
15. Supplementary Notes Project sponsored by the Texas Department of Transportation and the Federal Highway Administration. Project Title: Develop Design of Hot-Mix Cold-Laid Mixtures with the Superpave Gyratory Compactor URL: https://tti.tamu.edu/documents/0-7153-R1.pdf					
16. Abstract Hot-mix cold-laid (HMCL) asphalt mixes are crucial for maintaining asphalt pavements via blade-on/level-up patching. While the Superpave Gyratory Compactor (SGC) is widely used for hot-mix asphalt mixes due to its adjustable parameters and manageable compaction densities, the HMCL mix design still follows the Hveen mix design method, as per the Texas Department of Transportation (TxDOT) specification Item 334, using a Texas Gyratory Compactor. This study proposes a new HMCL mix design method that employs an SGC. This study examined five types of HMCL mixes, consisting of binders and aggregates commonly used in the industry. For each mix, three levels of binder content were determined following the TxDOT specification Item 334. These 15 laboratory-mixed HMCL mixes were then used to mold SGC specimens with four different compaction levels to establish the design gyration for SGC laboratory-molded densities in the range of 94.0 ± 1.5 percent. The study also found that the current specification may include mix designs with low compatibility. Specifically, the Hveen stability test in the specification was sometimes not sensitive to mix designs, leading to weak correlations with field performance. In developing a new mix design method, the Cantabro mass loss and IDEAL cracking and rutting tests were employed to characterize the resistance of mixes to raveling, cracking, and rutting. Binder contents significantly affected these test results. Moreover, mixes with low compactability were able to be excluded during testing specimen preparation. Therefore, the new HMCL mix design method using an SGC improved the current HMCL mix design method.					
17. Key Words Hot-mix Cold-laid, Hveen stability, Superpave Gyratory Compactor, Compactability, Cantabro Mass Loss Test, Ideal Rutting Test.			18. Distribution Statement No restrictions. This document is available to the public through NTIS: National Technical Information Service Alexandria, Virginia https://www.ntis.gov		
19. Security Classif. (of this report) Unclassified		20. Security Classif. (of this page) Unclassified		21. No. of Pages 86	22. Price

NEW MIX DESIGN METHOD FOR HOT-MIX COLD-LAID MIXTURES

by

Kin Ming Chan
Postdoctoral Research Associate
Texas A&M Transportation Institute

Fujie Zhou
Senior Research Engineer
Texas A&M Transportation Institute

and

Cindy Estakhri
Research Engineer
Texas A&M Transportation Institute

Report 0-7153-R1
Project 0-7153
Project Title: Develop Design of Hot-Mix Cold-Laid Mixtures with the
Superpave Gyratory Compactor

Sponsored by the
Texas Department of Transportation
and the
Federal Highway Administration

Published: June 2024

TEXAS A&M TRANSPORTATION INSTITUTE
The Texas A&M University System
College Station, Texas 77843-3135

DISCLAIMER

This research was sponsored by the Texas Department of Transportation (TxDOT) and the Federal Highway Administration (FHWA). The contents of this report reflect the views of the authors, who are responsible for the facts and the accuracy of the data presented herein. The contents do not necessarily reflect the official views or policies of FHWA or TxDOT. This report does not constitute a standard, specification, or regulation, and it is not intended for construction, bidding, or permit purposes. The engineer in charge was Dr. Fujie Zhou, P.E. (Texas, # 95969).

There is no invention or discovery conceived or first actually reduced to practice in the course of or under this contract, including any art, method, process, machine, manufacture, design, or composition of matter, or any new useful improvement thereof, or any variety of plant, which is or may be patentable under the patent laws of the United States of America or any foreign country.

The United States Government and the State of Texas do not endorse products or manufacturers. Trade or manufacturers' names appear herein solely because they are considered essential to the object of this report.

ACKNOWLEDGMENTS

This project was sponsored by TxDOT and FHWA. The authors thank the many personnel who contributed to the coordination and accomplishment of the work presented here. Special thanks are extended to Tom Schwerdt for serving as the project manager. Many people volunteered their time to serve as Project Monitoring Committee, including:

- Melissa Benavides.
- Gisel Carrasco.
- Enad Mahmoud.
- Clayton McCulloch.
- Travis Patton.
- Marta Stephens.

TABLE OF CONTENTS

LIST OF FIGURES	ix
LIST OF TABLES	xi
CHAPTER 1. INTRODUCTION	1
1.1 Background	1
1.2 Objectives	2
1.3 Report Organization	2
CHAPTER 2. LITERATURE REVIEW AND SURVEY	3
2.1 Review of the Current Hveem Mix Design, Specification Item 334	3
2.2 Usage and Performance of HMCL Mixes	6
2.3 Characteristics of High-Quality HMCL Mixtures in Previous Studies	11
2.4 Common Performance Tests for Characterizing HMCL Mixes	13
2.5 Use of SGC for HMCL Mix Design	18
2.6 Findings from Surveying Districts	19
2.7 Findings from Contacting Contractors	21
2.8 Summary	21
CHAPTER 3. LABORATORY EXPERIMENTAL TESTING PLAN FOR HMCL MIXES	23
3.1 Selection of HMCL Materials	23
3.1.1 Mix Types (or Aggregate Gradations)	23
3.1.2 Aggregate Types	24
3.1.3 Asphalt Binder Types	28
3.2 Balanced and Factorial Experiment Plan to Design HMCL Mixes with an SGC	28
3.3 Performance Tests Included in This Study	29
3.4 Summary of the Laboratory Experimental Test Procedure	30
CHAPTER 4. LABORATORY TEST RESULTS AND DISCUSSION	33
4.1 Phase I: Prescreening Performance Tests	33
4.1.1 Hveem Stability Test	33
4.1.2 Hamburg Wheel Track Test	34
4.1.3 IDEAL-RT Test	36
4.1.4 Cantabro Test	38
4.1.5 IDEAL-CT Test	40
4.1.6 Overlay Test	42
4.1.7 Selection of Performance Tests for the Proposed HMCL Mix Design Method	42
4.2 Phase II: HMCL Designs Using the Current Hveem Mix Design Method	43
4.3 Phase III: Development of the Proposed HMCL Mix Design Method	46
4.3.1 Requirement for the Compactability of the Mixes	47
4.3.2 Determination of N_{design}	49
4.3.3 Requirements for Performance Test Results	52
4.4 Summary of the Proposed HMCL Mix Design Method	56
CHAPTER 5. SUMMARY AND CONCLUSIONS	57

APPENDIX A. REVISED SPECIFICATION FOR ITEM 334..... 59
APPENDIX B. PROPOSED SPECIFICATION FOR IDEAL-RT TEST PROCEDURE..... 67
REFERENCES 73

LIST OF FIGURES

Figure 1. Districts Responding to Project 0-7109 Survey (February 2022).	8
Figure 2. District Survey Results for Maintenance Materials Available for Prep Work (February 2022).	9
Figure 3. Failure Symptoms and Mechanisms (Anderson et al., 1988).	10
Figure 4. Performance Tests for HMCL Mixes.	14
Figure 5. DWT Workability Determination.	15
Figure 6. IDEAL-RT Test Setup.	16
Figure 7. Laboratory-Molded Samples of LRA Stockpile Patching Mix before and after Cantabro Loss Tests.	17
Figure 8. SGC Compaction for Different HMCL Mixes (Chatterjee et al., 2006).	19
Figure 9. Aggregate Design for Limestone HMCL-D Mixes.	24
Figure 10. Aggregate Design for Gravel HMCL-D Mixes.	25
Figure 11. Aggregate Design for Limestone HMCL-B Mixes.	26
Figure 12. Aggregate Gradations of Limestone HMCL-D Mixes.	27
Figure 13. Aggregate Gradations of Gravel HMCL-D Mixes.	27
Figure 14. Aggregate Design for Limestone HMCL-B Mixes.	28
Figure 15. Flowchart of the Development of Proposed HMCL Mix Design Method.	32
Figure 16. SGC (left), IDEAL-CT (middle), and TGC (right) Specimens.	34
Figure 17. Specimen of HWTT.	35
Figure 18. Setup of HWTT.	35
Figure 19. Rut Depth after 1014 Load Passes.	36
Figure 20. Conditioning of IDEAL-RT Specimens.	36
Figure 21. Setup of IDEAL-RT Test.	37
Figure 22. Specimen after IDEAL-RT Test.	38
Figure 23. Setup of Cantabro Test.	39
Figure 24. Specimen after Cantabro Test.	40
Figure 25. Setup of IDEAL-CT Test.	41
Figure 26. Specimen after IDEAL-CT Test.	41
Figure 27. Conditioning of IDEAL-CT Specimens.	42
Figure 28. Relationships between Binder Contents and Corresponding TGC Laboratory- Molded Densities (Mix 1–4).	44
Figure 29. Relationship between Binder Contents and Corresponding TGC Laboratory- Molded Densities (Mix 5).	44
Figure 30. Relationships between Binder Contents and Corresponding TGC Laboratory- Molded Densities (Mix 1–4).	45
Figure 31. Relationship between Binder Contents and Corresponding TGC Laboratory- Molded Densities (Mix 5).	45
Figure 32. Results of Hveem Stability Tests.	46
Figure 33. Gyration of SCG Compactions in Molding IDEAL-CT Specimens.	48
Figure 34. Gyration of SCG Compactions in Molding Cantabro Specimens.	48
Figure 35. Temperature Change along Gyration of an HMCL Mix (Mix 5 with low BC) for Preparing an IDEAL-CT Specimen.	49
Figure 36. Relationships between SGC Laboratory-Molded Densities and Gyration of Limestone Mixes (Mix 1 and Mix 2).	50

Figure 37. Relationships between SGC Laboratory-Molded Densities and Gyrations of Gravel Mixes (Mix 3 and Mix 4).....	50
Figure 38. Relationships between SGC Laboratory-Molded Densities and Gyrations of Mix 5.....	51
Figure 39. Relationships between Binder Contents and SGC Laboratory-Molded Densities at a Compaction Level of 75 Gyrations.....	52
Figure 40. Results of Cantabro Tests.....	53
Figure 41. Results of IDEAL-CT Tests.....	53
Figure 42. Results of IDEAL-RT Tests.....	54
Figure 43. Relationship between Results of Cantabro and IDEAL-CT Tests.....	55

LIST OF TABLES

Table 1. HMCL Aggregates Gradation Designs (Item 334, 2014).....	4
Table 2. HMCL Property Requirements (Item 334, 2014).....	4
Table 3. HMCL Mix Trade-Off Design Parameters.	5
Table 4. Operational Tolerances.	6
Table 5. Summary of District Survey on HMCL Asphalt Mixes.	19
Table 6. Summary of Contacting Contractors on HMCL Asphalt Mixes.	21
Table 7. Factorial Experimental Plan for Designing HMCL Mixes with SGC.....	29
Table 8. Potential Performance Tests and Their Specifications for the New Mix Design Method.....	30
Table 9. IDEAL-RT Test Results of Plant-Mixed HMCL Mix.....	37
Table 10. Cantabro Test Results of Plant-Mixed HMCL Mix.....	40
Table 11. IDEAL-CT Test Results of Plant-Mixed HMCL Mix.....	42
Table 12. Binder Contents and Corresponding TGC Laboratory-Molded Densities (Determined from TxDOT Mix Design Spreadsheet).	43
Table 13. HMCL Property Requirements in Proposed Mix Design.	56

CHAPTER 1. INTRODUCTION

1.1 BACKGROUND

In Texas, hot-mix cold-laid (HMCL) asphalt mixes are commonly used for blade-on/level-up patching of pavements (Estakhri et al., 1999a, 1999b). These materials are designed to balance workability (ease of handling, loosening, and shoveling after long-term storage) and stability after compaction since they are often prepared in advance and stockpiled for maintenance activities. Up to date, HMCL mixes are designed using the Hveem mix design method according to the Texas Department of Transportation (TxDOT) specification Item 334 (Standard Specifications, 2014, Item 334, 2014). This method involves compacting mixes with a Texas Gyrotory Compactor (TGC) to mold specimens that meet certain requirements, such as sufficient stability in the Hveem stability test (Item 334, 2014).

However, the current HMCL mix design method has several drawbacks. For example, TGC compactions often require a lot of manual controls, which can lead to high variability and low reproducibility. The Strategic Highway Research Program (SHRP) has developed a more modern approach called the Superpave mix design method (Cominsky et al., 1994). This method uses a Superpave gyrotory compactor (SGC) instead of a TGC, offering several advantages over traditional compaction methods such as TGC and Marshall compactor compactions. These advantages include:

- SGC compactions are mainly machine-controlled, which results in better reproducibility.
- During SGC compactions, the gyrations and height of specimens are recorded, allowing for easier control of specimen volumes and densities. These records can also be used to determine the compactability of the mixes.
- SGC provides more adjustable compaction parameters such as internal gyration angle and compaction vertical stress. Thus, the compactions can be more consistent with field compactions by tuning the parameters.
- SGC can mold various heights of specimens, allowing for the use of different aggregate sizes and gradations. However, the TGC specimens have a fixed height of 2.00 inches (50.8 mm), and this volumetric requirement may not be suitable for larger aggregates.
- Most mixture performance tests use the specimens molded by the SGC rather than the TGC.

Due to the benefits of the SGC compactions, TxDOT has been transferring to SGC from TGC since the early 2000s (Button et al., 2006). The focus of this research project was to develop a new mix design method for HMCL materials using the SGC.

1.2 OBJECTIVES

The three objectives of this study were:

1. To determine the design gyration (N_{design}) of SGC ensuring that the HMCL mixes designed with SGC conform to current mixes designed with the Hveem mix design method.
2. To replace the Hveem stability test with new performance tests that use SGC specimens and are easy to use and closely related to field performance.
3. To address the compactability of HMCL mixes, since the current Hveem mix design method still results in poor compactability despite the increase in the TGC laboratory-molded density and accordingly binder content by Item 334.

1.3 REPORT ORGANIZATION

This report is organized into the following five chapters:

- Chapter 1: Introduction, with a brief description of the project background, objectives, and report organization.
- Chapter 2: Literature review and survey of the current state of practice of HMCL mix design method and performance tests.
- Chapter 3: Development of an experimental testing plan for establishing the new HMCL mix design method.
- Chapter 4: Laboratory test results and discussion.
- Chapter 5: Summary and conclusions.

Additionally, this report is accompanied by two appendices:

- Appendix A: Revised specification for Item 334.
- Appendix B: Proposed test standard for Ideal Cracking Test.

CHAPTER 2. LITERATURE REVIEW AND SURVEY

This chapter documents the current state of practice for the HMCL mix design method, laboratory performance tests, and field performance. The information provided serves as the foundation for the new HMCL mix design method using SGC. Additionally, the chapter includes findings from surveying districts and contacting contractors.

2.1 REVIEW OF THE CURRENT HVEEM MIX DESIGN, SPECIFICATION ITEM 334

HMCL mixes are described in Item 334 of TxDOT's construction specification book. These HMCL designs consist of dense-graded aggregates and asphalt binders, and may include additional additives blended in a hot-mix plant. The mixes are designed with asphaltic binders, allowing them to be stockpiled and applied coldly (Estakhri et al., 1999a, 1999b). HMCL is primarily used for maintenance applications, such as a blade-on/level-up material, rather than as a pothole repair material. Most districts use this material to prepare roads for the following year's seal coat program (Estakhri et al., 1999a, 1999b).

The mixes are designed according to the specification Tex-204-F, Part I, which requires that the mixes remain workable in a stockpile for at least six months (Tex-204-F, 2004). The design procedure originally required the use of a TGC with a target TGC laboratory-molded density of 92.5 ± 1.5 percent. However, since January 2022, all lettings will use the amendment SP334-003 with a TGC laboratory-molded density of 94.0 ± 1.5 percent (Item 334, 2014, SP334-003, 2021). This change in density is significant since it provides more cohesion to the mix, resulting in less raveling and better life from patches that may be exposed to traffic for one to two years before the seal coat, according to the Austin District. The increase in the TGC laboratory-molded density (and thereby increase in asphalt content) has been a positive change, improving the performance of the mixes in maintenance applications as well as their compaction. The general aggregate gradations and design properties of HMCL mixes in current mix designs are shown in Table 1 and Table 2, providing detailed information on the composition of the mix (Item 334, 2014, SP334-003, 2021).

Table 1. HMCL Aggregates Gradation Designs (Item 334, 2014).

Sieve Size	HMCL-A	HMCL-B	HMCL-C	HMCL-D	HMCL-F
	Cumulative Passing, %				
2"	100.0	—	—	—	—
1½"	98.0–100.0	100.0	—	—	—
1"	78.0–94.0	98.0–100.0	100.0	—	—
¾"	64.0–85.0	84.0–98.0	95.0–100.0	100.0	—
½"	60.0–70.0	—	—	98.0–100.0	100.0
¾"	—	60.0–80.0	70.0–85.0	85.0–100.0	98–100.0
#4	30.0–50.0	40.0–60.0	43.0–63.0	50.0–70.0	70.0–90.0
#8	22.0–36.0	29.0–43.0	32.0–44.0	35.0–46.0	38.0–48.0
#30	8.0–23.0	13.0–28.0	14.0–28.0	15.0–29.0	12.0–27.0
#50	3.0–19.0	6.0–20.0	7.0–21.0	7.0–20.0	6.0–19.0
#200	2.0–7.0	2.0–7.0	2.0–7.0	2.0–7.0	2.0–7.0

Table 2. HMCL Property Requirements (Item 334, 2014).

Property	Test Method	Requirement
Target TGC laboratory-molded density, %	Tex-207-F	94.0 ± 1.5
Hveem stability	Tex-208-F	> 35.0
Hydrocarbon-volatile content, %	Tex-213-F	< 0.6
Moisture content, %	Tex-212-F	< 1.0
Boil test, %	Tex-530-C	< 10.0

Discussions with contractors producing the HMCL (in the southern half of the state) showed typical asphalt binders used are AC-0.6 and AC-1.5. These soft binders provide a longer stockpile life.

The current aggregate gradation limits and properties of HMCL mixes are detailed in Table 1 and Table 2. Elsewhere, different trade-off parameters have been developed that aid in the creation of effective HMCL mixes. These mixes are designed to balance handling ease and performance. An example of trade-off parameters is presented in Table 3.

For aggregate gradations, reducing fines can improve workability, but excessing fines can reduce the stickiness of mixes. Coarse mixes (≥ 1.0 inch or 25.0 mm) present challenges in shoveling and spreading, while open-graded mixes may cure rapidly but are susceptible to water ingress.

A dense gradation could result in bleeding or a thin binder coating, leading to a dry mix with compromised durability. Conversely, an open or permeable mix may exhibit limited freeze-thaw resistance.

Regarding aggregate shape, angular and rough aggregates provide strong resistance to rutting and shoving but pose difficulties during handling. On the other hand, rounded and smooth aggregates offer good workability but exhibit poor resistance to rutting and shoving.

In terms of binder content, a higher content can improve workability, but lead to drain-down in the stockpile and potentially reduce skid resistance due to bleeding. This could further result in shoving and rutting. Conversely, an insufficient binder content may weaken the cohesion of the mix and increase its susceptibility to moisture.

Table 3. HMCL Mix Trade-Off Design Parameters.

Property	Parameter	Workability	Durability
Aggregate Gradation	Open-graded	Good	Poor
	Dense graded	Poor	Good
	One size	Good	
Aggregate Shape	Angular	Poor	Good
	Round	Good	Poor
Aggregate Size	Course	Poor	Good for well-prepared potholes (vertical, dry, etc.)
	Fine	Good	Good for shallow depth; poor for deep potholes
Binder Viscosity	Low viscosity	Good for storage	Poor
	High viscosity	Poor	Good
Binder Content (about 3.5–5.0%)	High	Good	Poor
	Low	Poor	Good
Compatible Anti-stripping			Good (protect binder coating on aggregates during storage and wet installation)

The aggregate gradation and asphalt binder content of the produced mix must adhere to the job mix formula (JMF) within the percentage point tolerances specified in Table 4. The gradation of the produced mix may deviate from the master grading limits for any sieve size ranging from 1½ inch to No. 50, provided that it remains within the JMF tolerances. The aggregate gradation of the No. 200 sieve must not exceed the master gradations indicated in Table 1. Any sieve size listed in Table 1 with a 100.0 percent passing requirement will be granted a 2.0 percent tolerance before being deemed out of specification.

Table 4. Operational Tolerances.

Property	Test Method	Operational Tolerance from JMF
Individual % retained for sieve sizes smaller than 1½ inch and larger than #8	Tex-200-F	± 5.0
Individual % retained for sieve sizes smaller than #8	Tex-200-F	± 3.0
Asphalt binder content, %	Tex-236-F	± 0.3
Laboratory-molded density, %	Tex-207-F	± 1.0

2.2 USAGE AND PERFORMANCE OF HMCL MIXES

In the research report 1717-1, titled *Evaluation of Texas DOT Item 334, Hot-Mix Cold-Laid Asphalt Concrete Paving Mixtures*, Estakhri et al. conducted laboratory tests on HMCL samples to assess the properties of mixes fabricated at different TGC laboratory-molded densities and to determine the suitability of these tests for differentiating between mixes with varying degrees of workability and cohesion (Estakhri et al., 1999a, 1999b). When preparing mixtures with varying densities, the asphalt content was also adjusted to achieve the target values. As a result, a lower density requirement, which necessitates less binder in the mix, is likely to provide better workability during winter. However, this improved workability may come at the cost of reduced cohesion and other performance. The specific testing results are summarized as follows (Estakhri et al., 1999a, 1999b).

Firstly, the curing time of loose mixes before compaction was examined by placing six different mix combinations into a forced-air oven set at 60 °C and allowing them to cure until they reached a constant weight. The samples were cured for an extended period (exceeding 10 days) to observe their specific weight loss characteristics (which will be discussed subsequently). Weight loss, which includes moisture and volatiles, is a crucial parameter for evaluating HMCL since it is directly related to workability. The curing process for HMCL samples to achieve a constant weight was time-consuming. In fact, some mixes required up to three days of oven-curing to attain 90.0 percent of the total weight loss (Estakhri et al., 1999a, 1999b).

For the Hveem stability test, samples were cast at three different densities. The results showed that the crushed limestone mixes exhibited significantly higher stability than the gravel mixes. Furthermore, designing mixes at lower TGC laboratory-molded densities did not have an adverse effect on the Hveem stability. Similarly, for the Marshall stability test, the crushed gravel mixes demonstrated significantly lower Marshall stabilities than the crushed limestone mixes. However, the stability values of the gravel mixes were not as strongly influenced by density as those of the crushed limestone mixes. For the limestone mixes, a stability peak was observed at 92.0 percent TGC laboratory-molded density for all binders used. With respect to the unconfined compression test, the compressive strength of the limestone mixes remained higher than that of

the gravel mixes. Most mixes reached their lowest strength at 95.0 percent density, compared to 89 and 92 percent densities (Estakhri et al., 1999a, 1999b).

Based on the cohesion test results, mixes designed at a TGC laboratory-molded density of 95.0 percent generally exhibited the best cohesion properties, with retention values ranging from 89.0 to 95.0 percent. In contrast, mixes designed at 92.0 percent density experienced a loss in cohesion, with retention values ranging from 75.0 to 88.0 percent. A significant loss of cohesion was observed in mixes designed at 89.0 percent density, with retention values typically ranging from 10.0 to 39.0 percent. SHRP Project H-348 recommended a minimum retention value of 60.0 percent. Both mixes designed at densities of 92.0 and 95.0 percent can meet this requirement (Estakhri et al., 1999a, 1999b).

The workability box test results revealed that all mixtures had values below 1.0, while the original acceptable limit, developed for high-performance pothole patching materials, was 3.0. No significant trends were observed for any of the mixes when subjected to the SHRP workability test. Since these materials produce higher workability values than HMCL mixes, the acceptable values for this test should be considered lower for HMCL mixes (Estakhri et al., 1999a, 1999b).

In general, most laboratory data suggest that the TGC laboratory-molded density requirements could be reduced to 92.0 percent (to improve winter workability) without compromising mix properties. Some material properties, such as the Marshall stability, showed improvement at a density of 92.0 percent. The primary concern with lowering the density requirement is the potential sacrifice in cohesion (the mixes may be more prone to raveling); however, the cohesion test did not indicate any issues with these mixes (Estakhri et al., 1999a, 1999b).

In addition to laboratory sample tests, aged stockpile HMCL samples from the field were also examined to investigate the effect of age on workability, cohesion, and other performance properties. Most of the mixes evaluated in the mentioned study exhibited poor winter workability but performed well in service. Specifically, mixes initially demonstrated excellent cohesion (70.0 to 95.0 percent) but dropped to values below 40.0 percent after six months in the stockpile. In terms of workability, most of the HMCL mixes evaluated in this study had much lower (better) workability ratings. The data did not indicate a significant correlation between workability rating and stockpile age; however, there was a slight trend of increasing workability rating with stockpile age (as would be expected). Marshall stability tests were performed on all field materials, and some mixes showed an increase in stability with age and a slight drop in stability with additional aging. The data trend of the unconfined compression test indicated an increase in compressive strength with stockpile age (Estakhri et al., 1999a, 1999b).

In the research project 0-7109, titled “Synthesis for Best Practices for Preventive Maintenance Preparatory Work,” researchers conducted a statewide survey on different maintenance materials available for prep work. There were 17 districts that responded, as shown in blue in Figure 1.

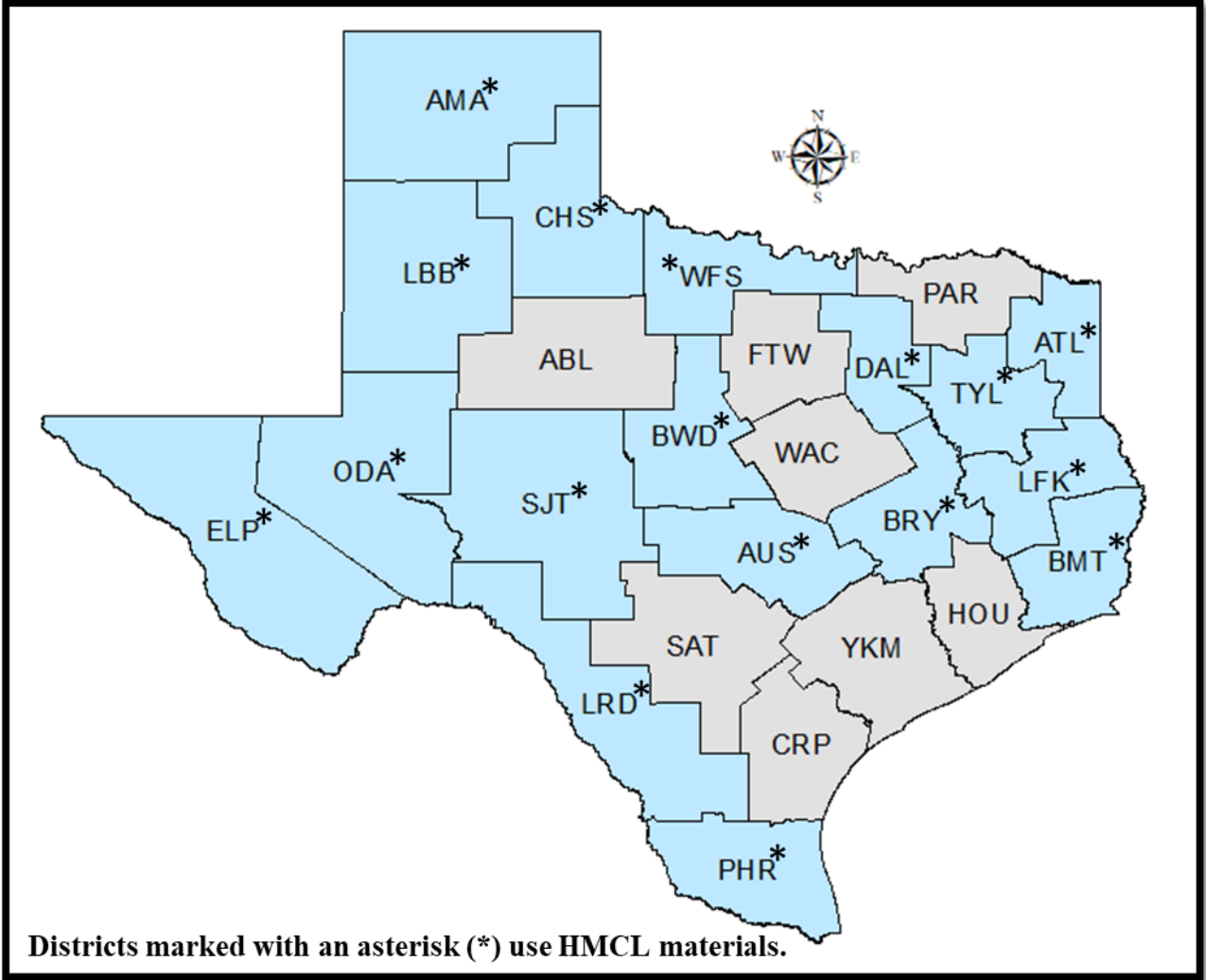

Figure 1. Districts Responding to Project 0-7109 Survey (February 2022).

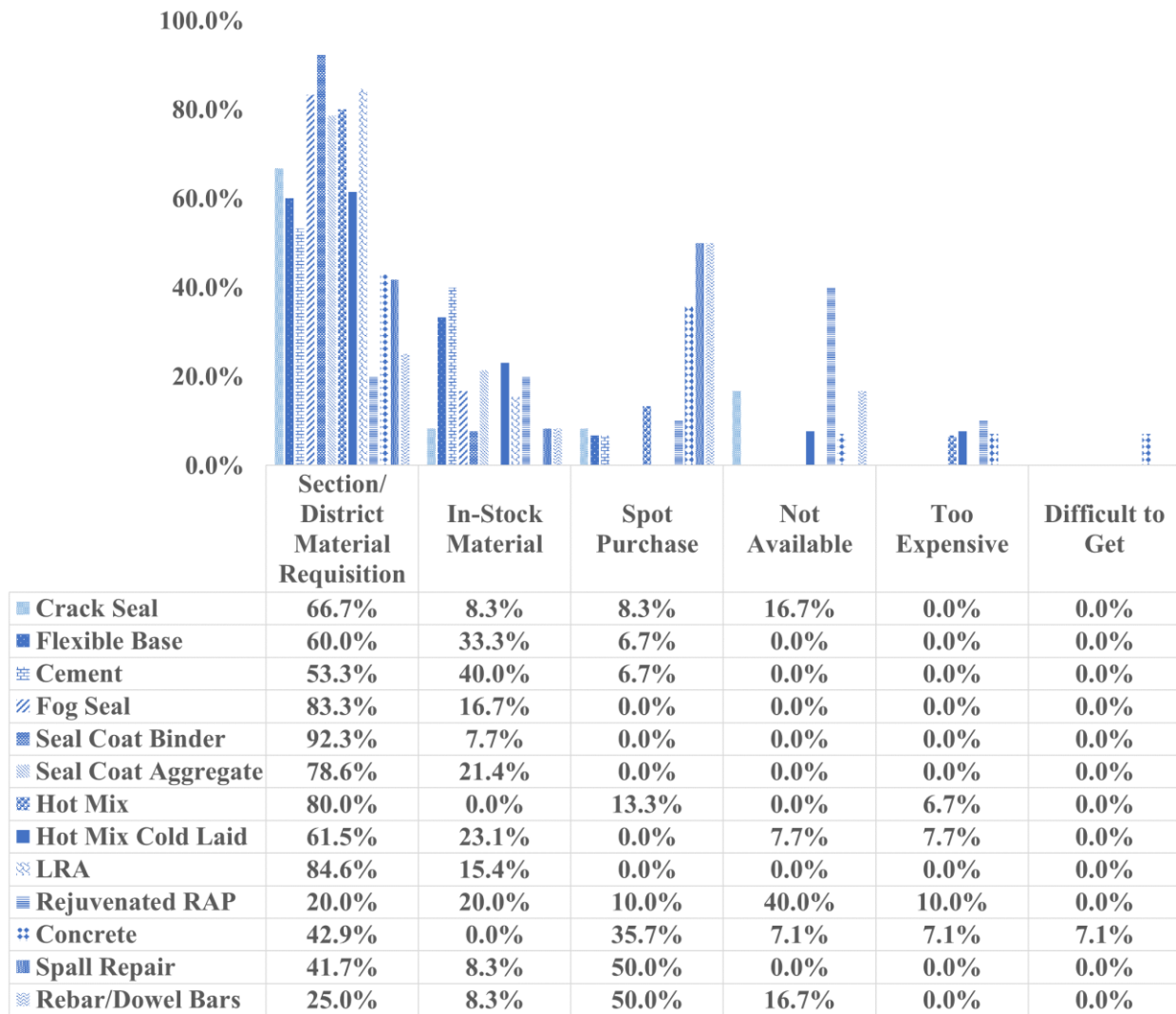

Figure 2. District Survey Results for Maintenance Materials Available for Prep Work (February 2022).

In summary, the use of cold patching mixes has been associated with multiple issues. These problems, or failure symptoms, may arise during storage in the stockpile, during material installation, or over the course of the mix’s service life. The various types of failure symptoms and mechanisms, which have been extensively documented and previously identified in the literature, are summarized in Figure 3 (Anderson et al., 1988).

Symptom	Failure Mechanism
In Stockpile	
Poor Workability	Binder too stiff; excessive fines or dirty aggregate; mix too coarse or too fine
Binder Draindown	Binder too soft; stockpiled or mixed at high temperatures
Stripping	Inadequate binder coating during mixing; cold or wet aggregate
Clumpy Mixture	Binder cures prematurely
Cold Weather Stiffness	Significant binder susceptibility to temperature; excessive fines or dirty aggregate; mix too coarse or too fine
During Placement	
Poor Workability	Binder too stiff; excessive fines or dirty aggregate; mix too coarse or too fine
Poor Stability	Binder too soft or excessive binder; insufficient voids in mineral aggregate; poor aggregate interlock
Excessive Softening (when used with hot box)	Binder too soft
In-Service	
Pushing, Shoving	Poor compaction; binder too soft or excessive binder; significant binder susceptibility to temperature; contaminated mixture; slow curing rate; moisture damage; insufficient voids in mineral aggregate; poor aggregate interlock
Dishing	Poor compaction
Raveling	Poor compaction; binder too soft; poor mixture cohesion; poor aggregate interlock; aggregate binder absorption; moisture damage; excessive fines or dirty aggregate; mix too coarse or too fine
Freeze-Thaw Deterioration	Mix too permeable; poor mix cohesion; moisture damage
Poor skid resistance	Excessive binder; aggregate not skid resistant; gradation too dense
Shrinkage or lack of adhesion to sides of hole	Poor adhesion; tack coat not used or mix not self-tacking; poor hole preparation

Figure 3. Failure Symptoms and Mechanisms (Anderson et al., 1988).

Problems commonly encountered in the stockpile include poor workability, binder drain-down, and stripping. Workability and the potential for drain-down are particularly influenced by the stiffness of the binder and the binder content, where excessive binder stiffness can cause these issues. Stripping, or loss of coating, in the stockpile can result from inadequate coating during the mixing process or the use of cold or wet aggregate. Other failure symptoms include clumpy and stiff mixtures. Clumpiness in mixtures is a direct consequence of the binder curing rate.

Mixtures stored in an unprotected stockpile typically form a thin crust due to the evaporation of volatiles. The thickness of this crust should be minimized to reduce the clumpiness of the mixture and prevent workability degradation. Workability degradation is a significant issue in cold weather since the temperature susceptibility of the binder can produce stiffer mixtures that are less workable (Anderson et al., 1988).

Workability and stability are crucial characteristics during mixture placement. A lack of these material characteristics must be avoided to prevent poor material performance. Extremes in binder stiffness are often the underlying cause of these symptoms. Other factors that may contribute to a loss in workability include excessive fines or dirty aggregate in a mixture, or a mixture with a gradation that is too coarse or too fine. A loss in stability can result from a lack of aggregate voids in the mineral aggregate or aggregate lock. Since material properties designed to improve these characteristics often conflict with one another, they must be carefully balanced to ensure proper installation and resistance to potential in-service failure symptoms (Anderson et al., 1988).

Distresses typically observed in the field, such as pushing, shoving, raveling, and dishing, are often a direct result of inadequate compaction during installation. Other causes of shoving and raveling may include insufficient binder stiffness or moisture damage. The presence of these distresses is particularly detrimental to the integrity and performance of patch installations since it can significantly accelerate the deterioration of patching mixtures. Another source of deterioration in areas with temperatures below freezing and large temperature differentials is the freeze-thaw cycle. Moisture damage and mixture permeability may trigger freeze-thaw deterioration. Poor skid resistance and shrinkage are other failure symptoms that are less frequently observed (Anderson et al., 1988).

2.3 CHARACTERISTICS OF HIGH-QUALITY HMCL MIXTURES IN PREVIOUS STUDIES

In Texas, the primary performance concern for HMCL mixes in existing studies is their behavior in cold and wet weather. Previous studies have indicated that high-quality HMCL materials must be well-designed in the following aspects (Chatterjee et al., 2006; Roberts et al., 1996; Kandhal & Mellott, 1981):

- **Stability:** An HMCL mixture must be stable under the prevailing traffic load. Poor stability can result in dishing and shoving of the mix.
- **Resistance to stripping:** Water can cause the asphalt binder to peel off the aggregates, a phenomenon known as stripping. Materials that are susceptible to stripping can ravel and ultimately cause patch failure.
- **Durability:** Ideally, HMCL materials should be able to withstand external loading (i.e., designated traffic) during their designed lifespan. However, issues such as inadequate cohesion within the mixtures, raveling, and stripping may shorten the life of the patch.

- **Workability:** This refers to the ability of the materials to be easily applied or placed, especially in winter using hand tools. Workability is achieved by using an adequate amount of relatively soft binder. Immediately after compaction, before the binder cures, the mix must be stable and not susceptible to pushing or shoving. This immediate stability is primarily obtained through careful attention to aggregate properties and gradation. Mix properties designed to improve workability may worsen stability; therefore, these two characteristics must be carefully balanced.
- **Storage:** A stockpiled HMCL mix should remain workable during storage time (typically six months). If the mix does not contain the right type of liquid asphalt binder, it can lose volatiles too rapidly and become harder over time. Additionally, mixes can develop drain-down issues if not well-designed for storage.
- **Freeze-thaw resistance:** This refers to the ability of the materials to withstand thermal expansion and contraction forces resulting from freeze-thaw cycles. Cracks and potholes develop more rapidly during freeze-thaw cycles.

As discussed in Figure 3, designing HMCL mixes is challenging due to the conflicting demands on the material to satisfy all performance criteria. The workability and stability properties must be balanced, taking into account the aggregate gradation and shape. Achieving a balance among storage stability, workability, and stability requires careful design when selecting binder viscosity and asphalt content. As previously discussed, the design criteria for HMCL asphalt mixes might require modifications. Given the challenges associated with the current Hveem mix design method and the concepts for enhanced design outlined in earlier studies, certain characteristics seem to be desirable for a satisfactory stockpile patching mix. These characteristics are (Roberts et al., 1996; Kandhal & Mellott, 1981):

- **Finer and predominantly one-size gradation:** A uniform gradation consisting of 100.0 percent passing the 9.5 mm (3/8 inch) sieve has the following advantages:
 - The mix is pliable and workable.
 - Due to the increased surface area that results from higher voids in mineral aggregate, binders can be incorporated into the mix to improve durability.
 - The mix remains pliable for a longer period and continues to get compacted under traffic.
- **Angular aggregate shape:** Angular aggregate shape is desirable for higher stability. If a finer and predominantly one-size gradation is used, the effect of aggregate angularity on the workability of the mix may be minimized. Angular crushed stone aggregate is an appropriate material.
- **Low aggregate absorption:** Highly absorptive aggregates should be avoided. The aggregate water absorption should be limited to less than 1.0 percent.
- **Proper binder type:** It should have relatively low viscosity at low temperatures so the mix remains workable when cold. Second, it should not lose volatiles at a fast rate, which would cause the mix to become unworkable in the stockpile.

- Adequate binder content: The literature indicates that at least 4.5 percent residual bituminous binder is required in a stockpile patching mix made from an aggregate whose water absorption is less than 1.0 percent. The factor limiting the maximum amount of the bituminous binder is drainage in the stockpile just after manufacture. The drainage can be minimized or eliminated by using a lower mix temperature and limiting the stockpile height.
- Proper type and amount of anti-stripping agent: A mix should retain its coating in the stockpile under adverse weather conditions, during handling, and in the pothole after placement. A stockpile patching mix is more pervious than dense-graded hot-mix asphalt (HMA) and thus more susceptible to severe weather and traffic effects. Spraying pavement striping paint on the stockpile surface can help reduce stripping and was one of the most effective treatments for HMCL mixes in laboratory evaluation. Extensive testing has shown that there is no single additive that works with all aggregate types. Thus, the type of anti-stripping agent and its rate of application must be selected after testing with the specific aggregate used in the mix.

In conclusion, while certain field performances such as stripping resistance are taken into account, the majority of existing HMCL material studies primarily concentrate on workability issues during stockpiling. Other field performances, including resistance to cracking and rutting, are often overlooked. The following subsection introduces a series of field performance-related tests for general HMA, aiming to identify potential performance tests for the development of a new HMCL mix design method that considers field performance.

2.4 Common Performance Tests for Characterizing HMCL Mixes

Some common performance tests that are easy to use for general HMA and HMCL mixes are shown in Figure 4.

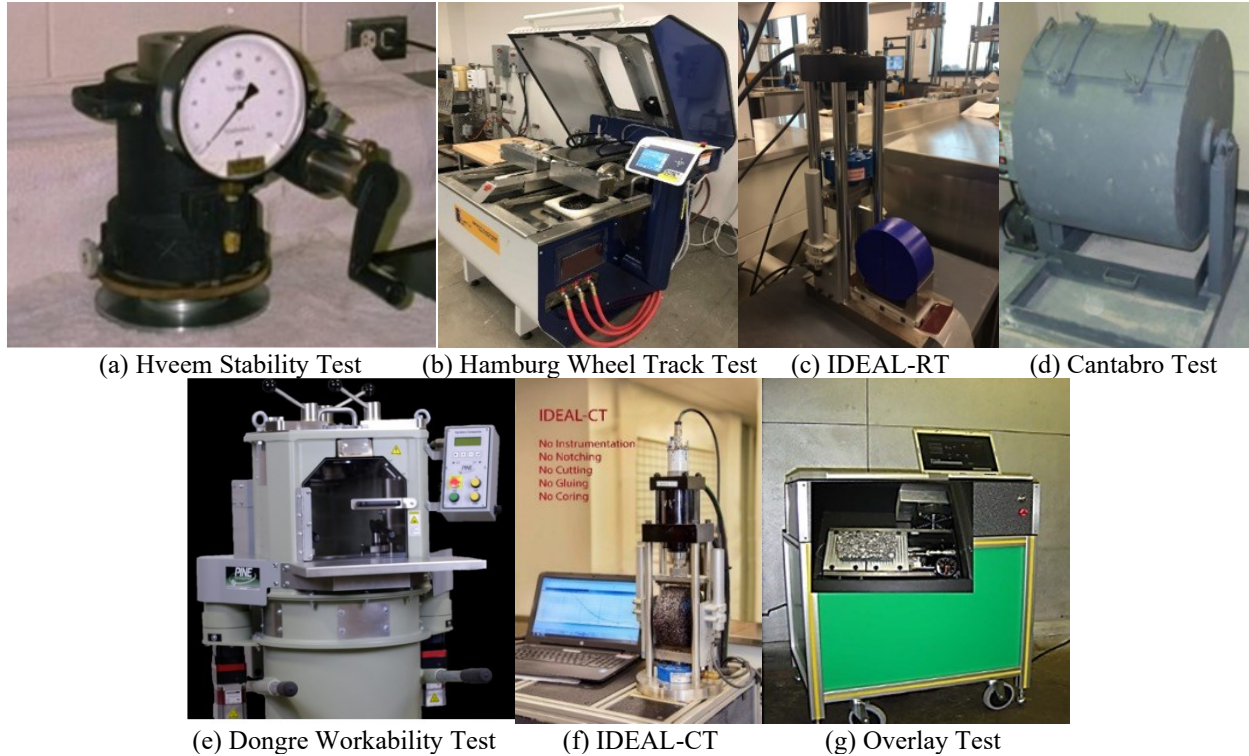

Figure 4. Performance Tests for HMCL Mixes.

Accordingly, the properties of HMCL mixes could be assessed using the tests shown in Figure 4:

- **Workability:** There are several tests used to measure the workability of cold mixes, and they are described as follows:
 - A potential test method for measuring the workability of cold mixes is under the American Association of State Highway and Transportation Officials (AASHTO) TP43-94 protocol. The test measures the relative penetration value of a plunger pushed into the mix held in a special metal box at 4 °C. Other states recommend the value be below 4 °C for the material to pass the workability test (Oregon Department of Transportation, 2016).
 - Another method that could be used to measure the workability of HMCL is the Dongre workability test (DWT). This new method uses the SGC to measure workability. The DWT is conducted under displacement control in the SGC using an asphalt loose mix. The workability of asphalt concrete is defined as the slope of the non-linear stress versus volumetric strain (%) curve calculated at 600 kPa stress level (Figure 5) (Dongré et al., 2013).

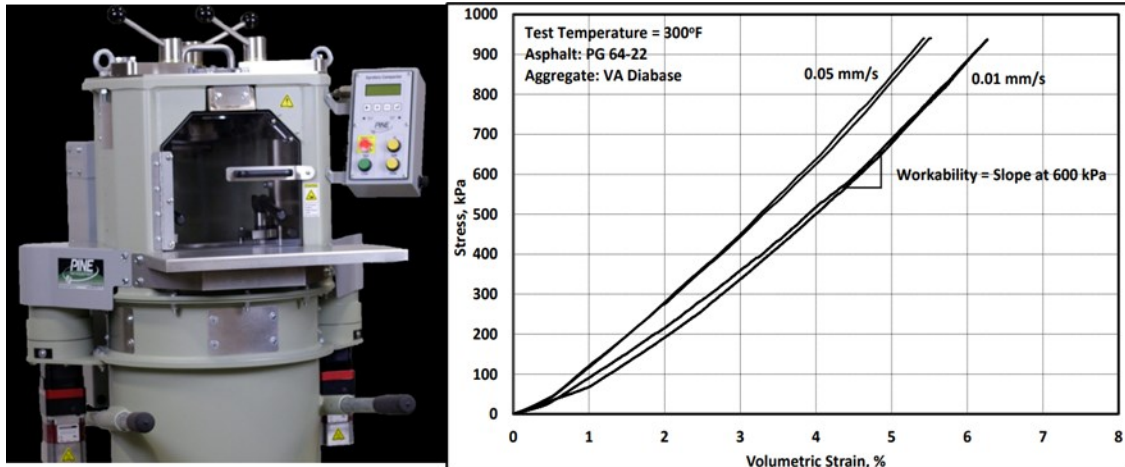

Figure 5. DWT Workability Determination.

- **Cohesion:** The purpose of the test is to assess the ability of the mixes to stick together. Hveem stability test (Figure 4a) has been used to measure cohesion.
- **Moisture susceptibility:** To simulate moisture susceptibility, the researchers could use the Hamburg Wheel Tracking Test (HWTT) (Figure 4b). The HWTT is a routine standard test, Tex-242-F, Hamburg Wheel Tracking Test, for evaluating the potential rutting and moisture damage of asphalt mixes (Tex-242-F, 2004). This test method determines the premature failure susceptibility of asphalt mixtures due to weakness in the aggregate structure, inadequate binder stiffness, moisture damage, and other factors including inadequate adhesion between the asphalt binder and aggregate. The original HWTT used an HMA slab with dimensions of 320.0 mm × 260.0 mm × 40.0 mm (12.6 inch × 10.2 inch × 1.6 inches). However, the test procedure was modified to accommodate gyratory molded samples: 150.0 mm (5.9 inches) diameter by 62.0 ± 2.0 mm (2.4 inches) height. The test is conducted in a water bath at a constant temperature: of 50 °C (122 °F). The sample is tested under a rolling 47.0-mm-wide (1.85-inch) steel wheel using a 705.0 N (158 lb) force. Rut depths are measured at several locations including the center of the wheel travel path, where usually it reaches the maximum value. One forward and backward motion is counted as two passes. It was found that asphalt binder performance grade (PG) has a significant influence on rutting and moisture damage. The pass/fail criteria are based on asphalt binder PG. For instance, for a mix with a PG 76-22 binder to pass, the mix must have a rut depth of less than 12.5 mm (0.5 inch) after 20,000 load passes.
- **Rutting resistance:** The IDEAL rutting test (IDEAL-RT) was recently developed to evaluate the rutting resistance of asphalt mixes using the Hamburg size samples (Figure 4c). IDEAL-RT is currently being balloted in ASTM WK71466: Standard Test Method for Determination of Rutting Tolerance Index of Asphalt Mixture Using the Rapid Rutting Test. It is run at a loading rate of 50.0 mm/min at the high temperature of 50 °C (the same temperature as HWTT) and is often completed within 2 minutes after taking a specimen out of the conditioning chamber (e.g., water bath). The IDEAL-RT

uses the Rutting Tolerance Index (RT-Index) as its rutting parameter, which directly characterizes the shearing strength of the asphalt mixes. Figure 6 shows the IDEAL-RT fixture. The larger the RT-Index, the better the rutting resistance of the mix. The IDEAL-RT has been validated using field rutting data from WesTrack, MnROAD, and several Texas test sections (Zhou et al., 2019). Three specimens with 150.0 mm (5.9 inches) in diameter and 62.0 (2.4 inches) mm in height are molded at 7.0 ± 0.5 percent air voids using a Superpave gyratory compactor. The IDEAL-RT is a rapid, simple, repeatable test that is sensitive to asphalt mix composition (aggregate, binder, recycled materials) and aging conditions.

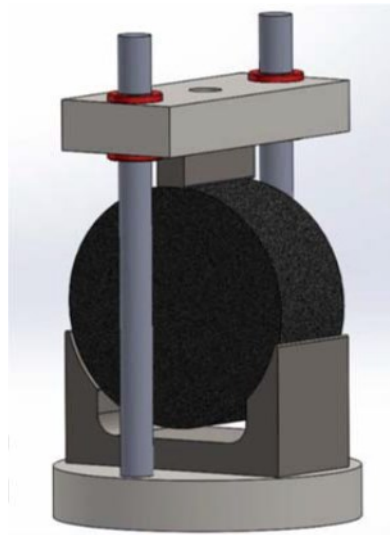

Figure 6. IDEAL-RT Test Setup.

- **Raveling resistance:** The Cantabro test has been widely used to evaluate the raveling potential of asphalt mixes (Figure 4d) (Tex-245-F, 2007). The Cantabro involves tumbling a laboratory-molded specimen in the Los Angeles Abrasion machine for a predetermined time and measuring the percentage of material that is lost from the specimen, as shown in Figure 7. Historically, this test has been used on permeable friction course mixes as an indication of the propensity of the mix for raveling. More recently it was implemented by TxDOT for LRA stockpile patching materials based on TxDOT research project 0-6686 (Estakhri et al., 2015). A laboratory-molded LRA sample is shown before and after Cantabro in Figure 7a. Additional Cantabro-tested specimens are shown in Figure 7b, showing that the specimen experiences more loss in material as flux oil content decreases (as expected). This is a clear indication that the test may be used to identify HMCL mixes that are too dry and prone to raveling. The Cantabro test measures the breakdown of compacted specimens utilizing the Los Angeles Abrasion machine. The percentage of weight loss (Cantabro loss) is an indication of porous friction course (PFC), LRA, and HMCL durability and relates to the quantity and quality of the asphalt binder. The Cantabro test consists of preparing 150.0 mm (6.0

inches) in diameter by 114.3 mm (4.5 inches) in height specimens and subjecting them to 300 revolutions in the Los Angeles abrasion machine without the steel spheres. After the test, the percentage of abrasion loss (i.e., percentage of mass loss) is determined based on the initial and final mass of the tested specimen, expressed as a percentage. Despite being a simple test, several studies have demonstrated that the results correlate well with field performance (Arambula-Mercado et al., 2019).



(a) LRA Specimen Before and After Cantabro Test



(b) Increasing Cantabro Loss as Flux Oil Content Decreases

Figure 7. Laboratory-Molded Samples of LRA Stockpile Patching Mix before and after Cantabro Loss Tests.

- **Cracking resistance:** Both the Texas Overlay Test (OT, Figure 4e) and the IDEAL cracking test (IDEAL-CT, Figure 4f) have been widely used in many states to evaluate the cracking resistance of asphalt mixes. The OT is a routine standard test, Tex-248-F, Overlay Test, for evaluating the susceptibility of asphalt mixtures to fatigue or reflective cracking (Tex-248-F, 2019). The key parts of the apparatus consist of two steel plates, one fixed and the other that moves horizontally to simulate the opening and closing of joints or cracks in old pavements beneath an overlay. The OT is often conducted in a cyclic triangle displacement-controlled mode with a maximum opening of 0.025 inch at a room temperature of 77 °F. The most often used loading frequency is 0.1 Hz (10 seconds per cycle). The OT specimen has a dimension of 6 inches × 3 inches wide × 1.5 inches high cut from Superpave gyratory compacted samples for field cores. The two key parameters for evaluating the cracking resistance of asphalt mixes are critical fracture energy and crack progression rate. The critical fracture energy is the energy required to initiate a crack on the bottom of the specimen at the first OT loading cycle, and it characterizes the fracture properties of the specimen during the crack initiation phase. The crack progression rate is the reduction in load required to propagate cracking under the cyclic loading conditions of the OT. This parameter characterizes the flexibility and fatigue properties of specimens during the crack propagation phase. In general, the smaller the crack progression rate, the better the cracking resistance.

The IDEAL-CT is a standard test in Texas, Tex-250-F, Ideal Cracking Test, for determining the cracking tolerance index (CT-Index) of compacted asphalt mixtures (Tex-250, 2019). The larger the CT-Index, the better the cracking resistance of the mixture. It is a monotonic test run with a loading rate of 50.0 mm/min at 25 °C. This test is often completed within 2 minutes after taking a specimen out of a conditioning chamber (e.g., water bath). The IDEAL-CT has been validated using field cracking data from the Federal Highway Administration accelerated loading facility, long-term pavement performance special pavement study 10, the National Center for Asphalt Technology test track, MnROAD, and numerous Texas test sections (ASTM D8360-22, 2022). A minimum of four specimens with 150.0 mm (5.9 inches) in diameter and 62.0 mm (2.4 inches) in height are molded at 7.0 ± 0.5 percent air voids using a Superpave gyratory compactor. The IDEAL-CT is a rapid, simple, reliable, repeatable test that is sensitive to asphalt mix composition (aggregate, binder, recycled materials) and aging conditions.

2.5 USE OF SGC FOR HMCL MIX DESIGN

SGC is a device designed for HMA compaction in the Superpave design. The device replaced the compaction devices for the Hveem and Marshall specimen preparations. A study indicated that when an SGC was used to compact cured and uncured cold mixes, it could not achieve densities of above 90 percent (Chatterjee et al., 2006). The study also noted that curing is essential to compaction, affecting the workability of the mixes. Furthermore, to simulate the workability of a mix in the stockpile and during placement, the study recommended that the mix be cured at 25 °C (77 °F). For stability of the mix in service, it was recommended to cure the mixes at 60 °C (140 °F) for 96 hours and then increase the mix temperature to 100 °C (212 °F) to compact the specimens for HWTT. Figure 8 shows an example of compaction for different HMCL mixes. The compaction curves indicate that almost all the compacted specimens have air voids between 11.0 and 14.0 percent. When the curing time was increased to 96 hours, the mixes approached or surpassed the final density of more than 90.0 percent at 200 gyrations (Chatterjee et al., 2006). Compaction was terminated at 200 gyrations or a final specimen height of 63.0 mm, whichever occurred first. An appropriate amount of material was used for the preparation of the specimens to achieve both termination conditions simultaneously. The tolerance limit for heights of compacted specimens for Hamburg stability testing is 62.0 ± 2.0 mm (2.4 inches). Because many specimens did not undergo 200 gyrations, this criterion was lowered to 60.0 mm to help ensure that all the specimens were subjected to the same compaction effort of 200 gyrations.

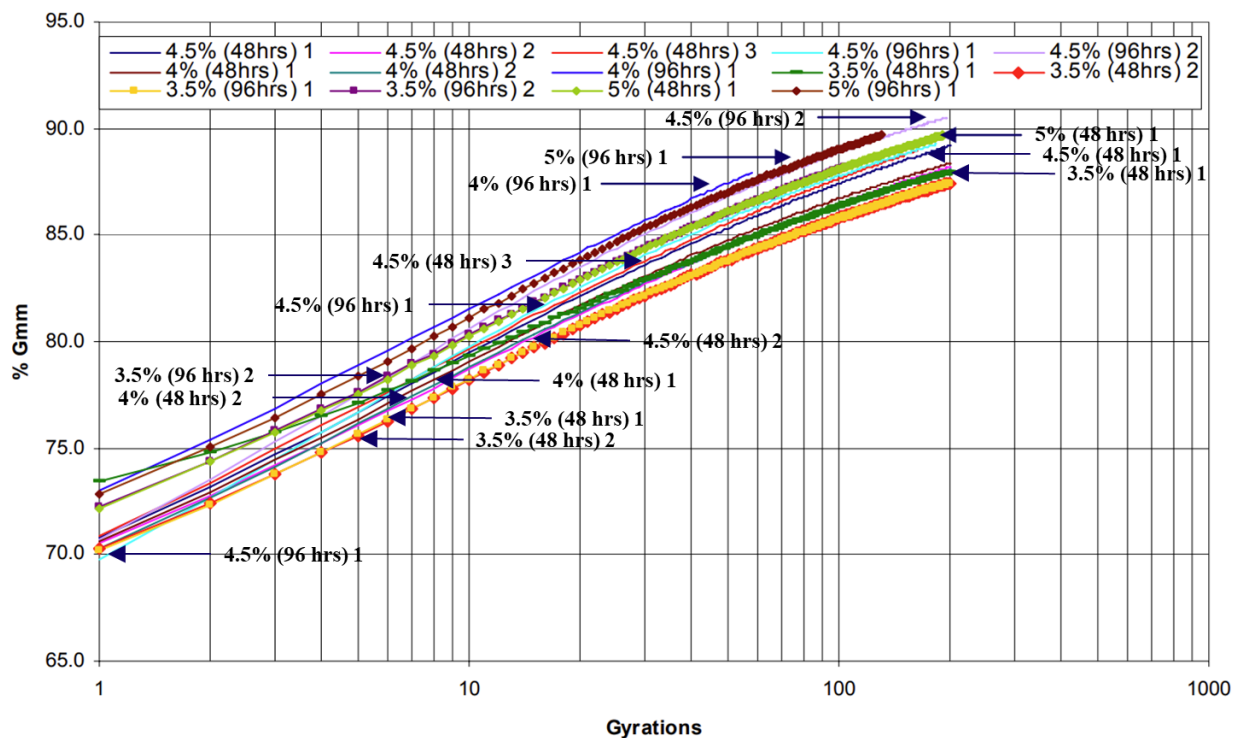

Figure 8. SGC Compaction for Different HMCL Mixes (Chatterjee et al., 2006).

2.6 FINDINGS FROM SURVEYING DISTRICTS

The research team surveyed the districts that historically used HMCL asphalt mixes. Table 5 presents the survey summary.

Table 5. Summary of District Survey on HMCL Asphalt Mixes.

District	Use of HMCL Asphalt Mixes
Atlanta	Use about 750 tons per year. The supplier is RK Hall. No performance issues.
Austin	Use mostly HMCL-D and HMCL-B mixes. The main supplier is Texas Materials.
El Paso	Use some HMCL. Shelf life can sometimes be an issue. They think sometimes it is already “old” by the time they get it. Sometimes they add a rejuvenator to the stockpile or MS-2 emulsions to liven it up.

District	Use of HMCL Asphalt Mixes
Lufkin	<p>Use HMCL-D mixes for the blade on level up.</p> <p>Out of nine counties, four use HMCL, others use LRA.</p> <p>Issues in the past (before 2015) with seal coats, too soft causes flushing. Those sections who remember that only choose to use LRA.</p> <p>The supplier is mainly East Texas Asphalt. Had some trouble in the recent past with Longview Asphalt, material set up in the stockpile too quickly and they made them come haul it off.</p>
Paris	<p>Currently do not use it a lot.</p> <p>Have used rejuvenated reclaimed asphalt pavement some.</p> <p>Had some problems in the past because they were using it as a blade on level-up before the seal coat and some of their seal coats had issues because the underlying patch was too soft. They talked to other districts who worked with suppliers and got the asphalt content reduced which helped.</p>
San Antonio	<p>Most common problem is having some major placement and workability issues with the product even though it tested okay in the lab. TxDOT sent out a special provision to Item 334 where they increased the TGC laboratory-molded density, which has helped with the workability in the field. Getting more asphalt into the mix has helped. A few years back they had a lot of recycled engine oil bottom (REOB) used in the mix by the supplier, which caused performance issues, particularly lots of raveling.</p> <p>Until they got new provision they had buy-in from producers to give 96.5 density in the lab. Maintenance uses HMCL-D and C mixes, primarily HMCL-D, and some HMCL-B mixes.</p> <p>No particular stockpile issues.</p>
Waco	<p>Very limited use of HMCL.</p>
Wichita Falls	<p>Do not use HMCL or LRA materials. Have about five HMA plants around the district, and they are always producing mix for either construction or maintenance.</p> <p>Shelf life for any type of cold mix can be an issue and it is just easier and better to purchase it hot.</p> <p>They primarily use an HMCL-D mix (PG 64-22 binders) for maintenance work with either a laydown machine or blade-on level-up or base repair. Do not lay HMCL-B mixes.</p>
Yoakum	<p>Use HMCL for level-up. Use LRA for deep repairs.</p> <p>No particular issues now. Previously that had some problems with Century Asphalt. The mix was too greasy but worked with them and got it resolved. Century (Tx Mat'ls) has not bid in the past few years due to problems with trucking.</p> <p>Current Suppliers: Quality Hot Mix from El Campo (but they have also had some trucking issues), BraunTex Materials from New Braunfels, Colorado Materials from Nursery (newer supplier and maintenance personnel claim it is a little harder to blade because they use a manufactured aggregate.)</p>

2.7 FINDINGS FROM CONTACTING CONTRACTORS

The research team also contacted different contractors producing HMCL asphalt mixes. Table 6 lists the discussion with contractors.

Table 6. Summary of Contacting Contractors on HMCL Asphalt Mixes.

Contractor	Information about HMCL Asphalt Mixes
#1	<p>HMCL-D mixes are most commonly used.</p> <p>Use AC-0.6 binder and limestone aggregates from Marble Falls.</p> <p>No particular performance issues were noted.</p> <p>Have never tried designing with Superpave Press but plan to do some this winter. Do not foresee any problems designing with the Superpave press but suggest using a 35-gradation design to ensure that enough binder gets in the mix.</p>
#2	<p>Mostly produce HMCL-D mixes. Supply to TxDOT, cities, and counties.</p> <p>Use AC-0.6 binders and a blend of limestone, granite, and sand.</p> <p>No particular performance issues were noted.</p> <p>Have tried designing in the Superpave but have not been successful. Cannot achieve the required density in the Superpave.</p>
#3	<p>HMCL-D mixes are the most common mixes. Produce at multiple plants in the state. Working on designs now.</p> <p>Use AC-0.6 binders and provide a design using 70.0 percent gravel and limestone screenings.</p> <p>No particular performance issues were noted.</p> <p>Have never tried designing in a Superpave but offered to help with some designs.</p>

2.8 SUMMARY

Generally, prior studies indicate that HMCL mixes, designed using the conventional Hveem mix design method with TGC laboratory-molded densities ranging from 92.0 percent to 95.0 percent, can offer excellent workability. Higher densities contribute to increased cohesion, stability, and durability. Furthermore, literature reviews and district surveys suggest that a balance between the workability and stability of HMCL mixes can be achieved when they are composed of soft binders, such as AC-0.6 binders, and crushed dense graded aggregates like crushed limestone HMCL-D aggregates.

Despite the consideration of certain field performances such as stripping resistance in existing HMCL studies, the primary focus often remains on workability issues during stockpiling. Other field performances, including resistance to cracking and rutting, are frequently neglected.

Moreover, the specification Item 334 typically results in dry HMCL mixes with low binder contents, leading to high workability but reduced compactability. Consequently, some mixes may pose challenges in compaction and paving, especially during winter. In essence, field performance and compactability are rarely considered in current studies and specifications. Thus, it becomes imperative to substitute the Hveem stability test with new performance tests and incorporate the compactability of HMCL mixes in the development of a novel HMCL mix design method.

CHAPTER 3. LABORATORY EXPERIMENTAL TESTING PLAN FOR HMCL MIXES

This chapter outlines the development of an experimental testing plan to establish a new HMCL mix design method using SGC. The new method should include the following components:

1. A compaction level, determined by the number of gyrations, corresponds to a specific laboratory-molded density range.
2. Performance tests to ensure good field performance.
3. A balance among durability, workability, and compactability.

To achieve these goals, the research team has completed the following tasks:

1. Selection of appropriate HMCL materials.
2. Establishment of a balanced and factorial experiment plan to design HMCL mixes with TGC.
3. Recommendation of potential performance tests for the new HMCL mix design method.

The following subsections of this chapter describe the above process in more detail. Then, a summary of the procedure for the development of the new HMCL mix design method is provided.

3.1 SELECTION OF HMCL MATERIALS

The proposed mix design method for HMCL materials is developed by investigating various types of laboratory-mixed HMCL mixes. The selection of HMCL materials should take into account the designs of mix types (i.e., aggregate gradations), aggregate types, and asphalt binder types. This selection is based on several factors, including the specification Item 334, the balance between workability and durability, and common practices among contractors working with HMCL asphalt mixes in the state. These considerations are informed by literature reviews, district surveys, and contractor interviews conducted in Chapter 2.

3.1.1 Mix Types (or Aggregate Gradations)

The aggregate gradations for HMCL mix designs primarily adhere to the specification Item 334. These designs propose five types of dense-graded master gradation limits for HMCL materials, designated as HMCL-A to D and HMCL-F, as shown in Table 1.

According to the district surveys conducted in the previous chapter, the HMCL-D gradation is generally the most widely used in districts throughout Texas, followed by the HMCL-B gradation. As a result, these two gradations will be the primary focus of the project.

3.1.2 Aggregate Types

Based on discussions with contractors, crushed limestone and gravel aggregates are commonly used for HMCL materials. These aggregates have been extensively studied for their suitability in HMCL applications, as detailed in TxDOT research report 1717-1 (Estakhri et al., 1999a, 1999b). This project thus concentrates on the study of crushed limestone and gravel aggregates. The crushed stones and sand from the stockpiles will undergo a process of drying, sieving, and batching to ensure each mix aligns with the desired gradation. It is challenging to obtain the desired gradation with a single source of aggregate. As a result, all mixes in this study consist of multiple sources of aggregates. Figure 9–Figure 11 display snapshots of the combined aggregate design from TxDOT for the mixes used in this study. Figure 12–Figure 14 provide the sieve analysis on the combined aggregate of the mixes.

Aggregate	Bin No.1		Bin No.2		Bin No.3		Bin No.4	
Source:	Limestone_Dolomite		Limestone_Dolomite		Limestone_Dolomite			
Pit:	HC		HC		HC		River Bend	
Number:								
Producer:	KR		KR		KR		Knife River	
Sample ID:	D		F		Washed Screenings		Sand	
Hydrated Lime?:								
Individual Bin (%):	25.0	Percent	30.0	Percent	35.0	Percent	10.0	Percent
48.1								
Sieve Size:	Cum.% Passing	Wtd Cum. %	Cum.% Passing	Wtd Cum. %	Cum.% Passing	Wtd Cum. %	Cum.% Passing	Wtd Cum. %
3/4"	100.0	25.0	100.0	30.0	100.0	35.0	100.0	10.0
1/2"	100.0	25.0	100.0	30.0	100.0	35.0	100.0	10.0
3/8"	89.4	22.4	100.0	30.0	100.0	35.0	100.0	10.0
No. 4	4.5	1.1	65.0	19.5	99.8	34.9	100.0	10.0
No. 8	0.7	0.2	9.5	2.9	90.1	31.5	99.9	10.0
No. 30	0.4	0.1	2.5	0.8	36.5	12.8	94.9	9.5
No. 50	0.4	0.1	2.1	0.6	19.5	6.8	45.7	4.6
No. 200	0.3	0.1	1.4	0.4	4.0	1.4	2.0	0.2

Figure 9. Aggregate Design for Limestone HMCL-D Mixes.

Aggregate	Bin No.1		Bin No.2		Bin No.3		Bin No.4	
Source:	Gravel		Gravel		limestone_Dolomite		limestone_Dolomite	
Pit:	Young		Young		Pate		Pate	
Number:	0907402		0907402		0914710		0914710	
Producer:	Big Creek Construction		Big Creek Construction		Cedar Creek Stone		Cedar Creek Stone	
Sample ID:	D/F		MANF. SCRNGS.		FINE SCRNGS.		D	
Recycled Material?:								
Asphalt %:								
Hydrated Lime?:								
Individual Bin (%):	30.0	Percent	35.0	Percent	15.0	Percent	20.0	Percent
Sieve Size:	Cum.% Passing	Wtd Cum. %	Cum.% Passing	Wtd Cum. %	Cum.% Passing	Wtd Cum. %	Cum.% Passing	Wtd Cum. %
3/4" 39.000	100.0	30.0	100.0	35.0	100.0	15.0	100.0	20.0
1/2" 49.000	100.0	30.0	100.0	35.0	99.9	15.0	100.0	20.0
3/8" 59.000	88.9	26.7	100.0	35.0	99.8	15.0	76.5	15.3
No. 4 67.500	19.7	5.9	100.0	35.0	99.3	14.9	4.1	0.8
No. 8 73.500	0.9	0.3	64.0	22.4	99.0	14.8	3.0	0.6
No. 30 85.000	0.6	0.2	20.3	7.1	96.1	14.4	2.9	0.6
No. 50 89.000	0.5	0.2	5.0	1.8	85.7	12.9	2.8	0.6
No. 200 90.750	0.4	0.1	0.6	0.2	13.0	2.0	1.8	0.4

Figure 10. Aggregate Design for Gravel HMCL-D Mixes.

Aggregate	Bin No.1		Bin No.2		Bin No.3		Bin No.4		Bin No.5	
Source:	Limestone_Dolomite		Limestone_Dolomite		Limestone_Dolomite		Limestone_Dolomite			
Pit:	Servtex						Servtex		River Bend	
Number:	1504603						1504603			
Producer:	Hanson Aggregates						Hanson Aggregates		Knife River	
Sample ID:	B		C		D		Washed Screenings		Sand	
Hydrated Lime?:										
Individual Bin (%):	10.0	Percent	18.0	Percent	39.0	Percent	18.0	Percent	15.0	Percent
48.1										
Sieve Size:	Cum.% Passing	Wtd Cum. %	Cum.% Passing	Wtd Cum. %	Cum.% Passing	Wtd Cum. %	Cum.% Passing	Wtd Cum. %	Cum.% Passing	Wtd Cum. %
1-1/2"	100.0	10.0	100.0	18.0	100.0	39.0	100.0	18.0	100.0	15.0
1"	100.0	10.0	100.0	18.0	100.0	39.0	100.0	18.0	100.0	15.0
3/4"	67.7	6.8	100.0	18.0	100.0	39.0	100.0	18.0	100.0	15.0
3/8"	24.6	2.5	7.5	1.3	65.0	25.4	100.0	18.0	99.8	15.0
No. 4	7.2	0.7	1.8	0.3	27.1	10.6	99.6	17.9	98.1	14.7
No. 8	4.6	0.5	1.6	0.3	12.3	4.8	78.9	14.2	76.8	11.5
No. 30	3.2	0.3	1.4	0.3	8.0	3.1	37.7	6.8	53.0	7.9
No. 50	3.0	0.3	1.3	0.2	6.3	2.5	20.7	3.7	22.4	3.4
No. 200	2.6	0.3	1.0	0.2	4.6	1.8	14.8	2.7	3.6	0.5

Figure 11. Aggregate Design for Limestone HMCL-B Mixes.

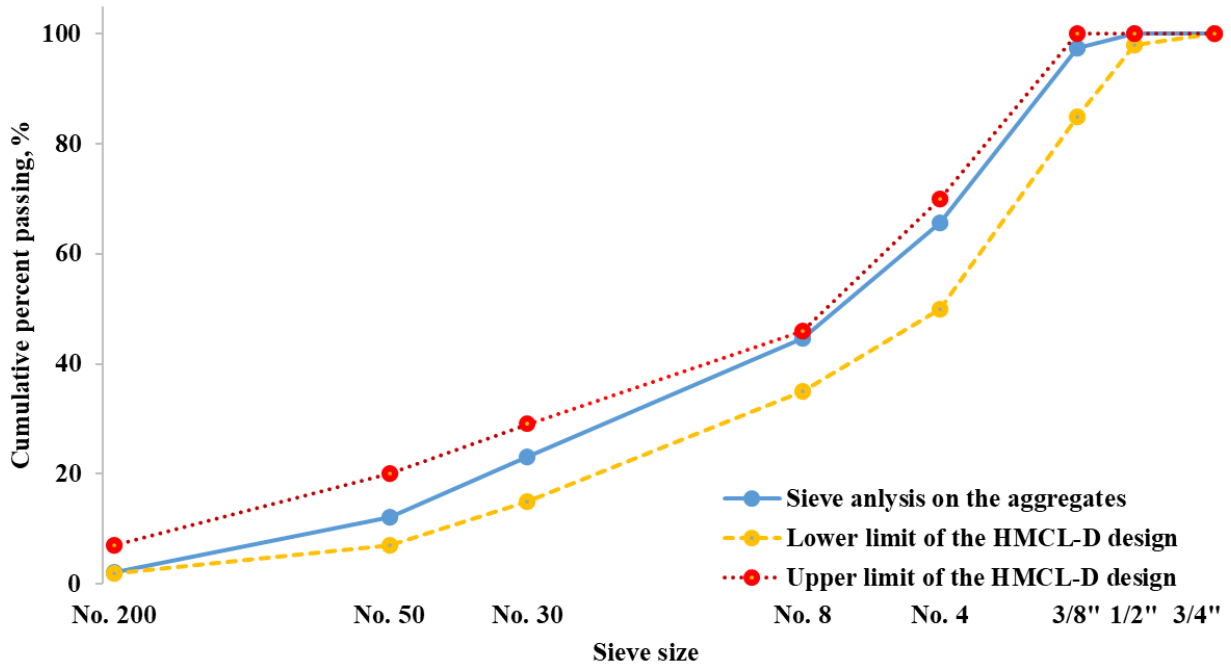

Figure 12. Aggregate Gradations of Limestone HMCL-D Mixes.

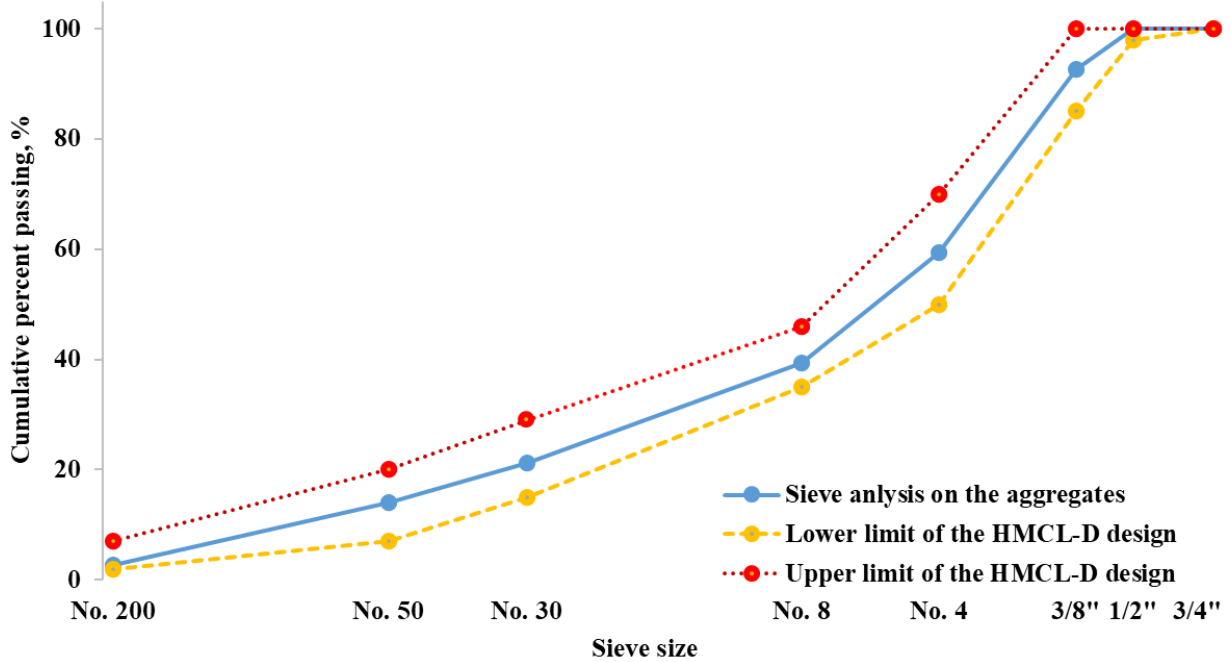

Figure 13. Aggregate Gradations of Gravel HMCL-D Mixes.

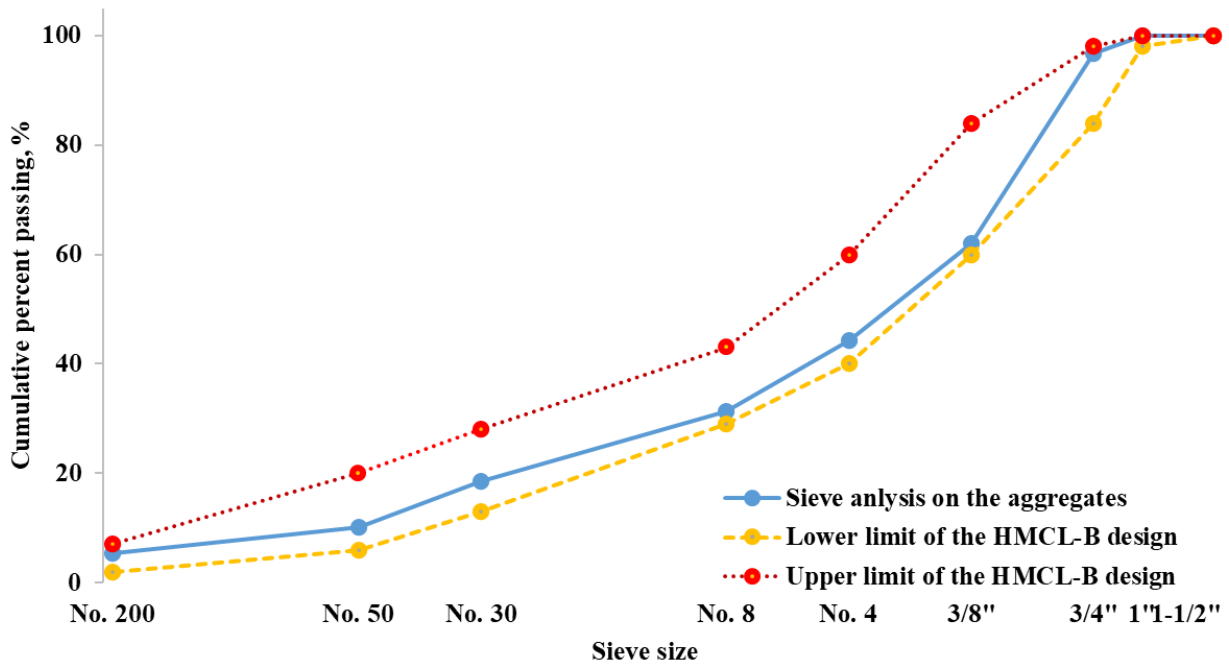

Figure 14. Aggregate Design for Limestone HMCL-B Mixes.

3.1.3 Asphalt Binder Types

According to the survey in the previous chapter, AC-0.6 binders are the most popular asphalt binders applied for HMCL materials, followed by AC-1.5 binders. Two AC-0.6 binders from binder suppliers 1 and 2 were collected and used for the study. In summary, in this study, the HMCL mixes are made of dense-graded crushed aggregates with soft binders. The gradations and the angular shapes of aggregates provide good durability while the low viscosities of the binders improve the workability of the mixes. Therefore, the selected designs shown in Table 3 are widely applied for HMCL mixes in the state.

3.2 BALANCED AND FACTORIAL EXPERIMENT PLAN TO DESIGN HMCL MIXES WITH AN SGC

This section presents a fractional factorial design for the HMCL mixes, which are designed based on the specification Item 334. The factors considered in the experimental plan include aggregate gradation, aggregate type, and asphalt binder type. Given that two aggregate gradations, two aggregate types, and three asphalt binder types are considered, this results in twelve types of HMCL mixes, as depicted in Table 7. Each empty cell in the table represents a mix corresponding to the factors. By employing the D-Optimal Experimental Design (<https://www.itl.nist.gov/div898/handbook/pri/section5/pri521.htm>), the size of the test can be reduced, and the study concentrates on five types of laboratory-mixed HMCL mixes (Mix 1–5), as shown in Table 7.

Table 7. Factorial Experimental Plan for Designing HMCL Mixes with SGC.

Binder Type	Aggregate Gradation			
	HMCL- D		HMCL-B	
	Aggregate Type			
	Crushed Limestone	Crushed Gravel	Crushed Limestone	Crushed Gravel
AC-0.6 (Supplier 1)	Mix 1	Mix 3	Mix 5	
AC-0.6 (Supplier 2)	Mix 2			
AC-1.5 (Supplier 3)		Mix 4		

Therefore, these five types of mixes with corresponding factors will be designed according to the specification Item 334 with a mixing temperature of 250 °F and compaction temperature of 140 °F. Those temperatures are also applied for all mixes in the study unless they are specified. In the specification, the TGC laboratory-molded density in the current Hveem mix design method is not a fixed value but within a range of 94.0 ± 1.5 percent (SP334-003 effective January 2022 letting, statewide use), which is significantly different from asphalt mix designs in other specifications like Items 340/341, 342, 344, and 346 (Tex-207-F, 2007). For each type of mix given in Table 7, three levels of binder content (BC) (i.e., high, medium, and low BC) are determined according to the TGC laboratory-molded density range of 94.0 ± 1.5 percent and other requirements shown in Table 2. As a result, a total of 15 HMCL mixes designed according to specification Item 334 were adopted. The proposed mix design method was constructed through a study of these mixes.

3.3 PERFORMANCE TESTS INCLUDED IN THIS STUDY

In addition to specifying the gyrations and densities, the new HMCL mix design method should also establish performance requirements for the mixes. According to the reviews from Chapter 2, performance indicators such as cohesion, rutting resistance, raveling resistance, and cracking resistance can be evaluated through a series of tests. These tests include the HWTT, IDEAL-RT Test, Cantabro Test, IDEAL-CT Test, and Overlay Test, as illustrated in Figure 4. They thus become the potential performance tests of the new HMCL mix design method. Moreover, the Hveem Stability Test is crucial for this study since it is the performance test currently used in the Hveem mix design method for HMCL mixes. Hence, all performance tests that this study focused on, along with their respective specifications, are outlined in Table 8.

Table 8. Potential Performance Tests and Their Specifications for the New Mix Design Method.

Test	Specification
Hveem Stability Test	Tex-208-F
Hamburg Wheel Track Test	Tex-242-F
IDEAL-RT Test	ASTM D8360-22
Cantabro Test	Tex-245-F
IDEAL-CT Test	Tex-250-F
Overlay Test	Tex-248-F

The study should provide ranges of test results for the above performance tests, excluding the Hveem Stability Test, which is only used for TGC mix designs of Mix 1–5. These ranges can be adopted as specifications for the new mix design that aligns with the current TGC design method. It is thus necessary to test all 15 mixes to determine the lower limits of performance for HMCL mixes. Additionally, since the gyrations and height of specimens are recorded during the molding of test specimens with an SGC, these gyrations can serve as an indicator of compactability. Therefore, the gyrations of test specimens for mixes with good compactability can be identified and used to establish an upper limit for gyrations in the new mix design method.

However, it is well-known that some aspects of HMCL material performance are not as satisfactory as general HMA due to the trade-off between durability and workability. Additionally, some tests may not be feasible due to difficulties in preparing specimens caused by the weak cohesion of HMCL materials. Therefore, before proceeding with the development of a new mix design method using laboratory-mixed samples, it is crucial to recognize performance tests from Table 8 that can be properly applied to HMCL mixes. A plant-mixed HMCL mix from an aggregate supplier was collected and subjected to various tests to identify and prescreen the most appropriate performance tests for HMCL materials before the investigation of the 15 laboratory-mixed HMCL mixes.

3.4 Summary of the Laboratory Experimental Test Procedure

To summarize, the laboratory experimental tests are organized into three distinct phases: prescreening performance test (Phase I), mix designs based on the current Hveem mix design method (Phase II), and development of the proposed mix design method (Phase III).

In Phase I, a plant-mixed HMCL mix, obtained from an aggregate supplier, undergoes a series of tests, as outlined in Table 8. This process aids in identifying appropriate tests for HMCL materials.

Phase II involves the use of the current Hveem mix design method to formulate mix designs for laboratory-mixed HMCL mixes. These mixes are mainly used in developing a new mix design method. The new method is derived from an analysis of 15 laboratory-mixed HMCL mixes, which are from 5 different mix types (Mix 1–5 in Table 7). Each type has three levels of binder content (i.e., high, medium, and low BC) determined according to the TGC laboratory-molded density range of 94.0 ± 1.5 percent and other requirements in the TGC mix design method (Table 2).

In Phase III, the HMCL property requirements for the proposed mix design method are established. Since the proposed method is designed to align with the current Hveem mix design method while considering field performance and compactability, these requirements include the SGC laboratory-molded density for a gyration of N_{design} , maximum gyrations for molding test specimens, and minimum performance in the tests of the mixes.

To ensure conformity with the original mix design, SGC specimens are molded for each laboratory-mixed HMCL mix in Phase II at various compaction levels (i.e., 50, 75, 100, and 125 gyrations). This process helps establish relationships between the gyrations and densities of the 15 mixes designed with the original mix design. These relationships are then used to identify the N_{design} value for the prescribed SGC laboratory-molded density (94.0 percent) for the new mix design method.

Selected performance tests from Phase I are conducted on all 15 mixes to evaluate their performance as well as the gyrations needed to mold test specimens. This aids in developing standards of compactability and field performance for the proposed mix design method. All TGC and SGC compactations in this study adhere to specification Tex-204-F, where a mixing temperature of 250 °F (121.1 °C) and a compaction temperature of 140 °F (60 °C) are applied (Tex-204-F, 2004). In line with Superpave requirements, the SGC gyration angle is 1.25 degrees and the vertical stress is 600 kPa. All specimens undergo 30 gyrations per minute.

Figure 15 details the development of the proposed HMCL mix design method, derived from the work on 15 laboratory-mixed HMCL mixes. This work can be divided into two parts based on the compactations of specimens: TGC compactations (Phase II) and SGC compactations (Phase III).

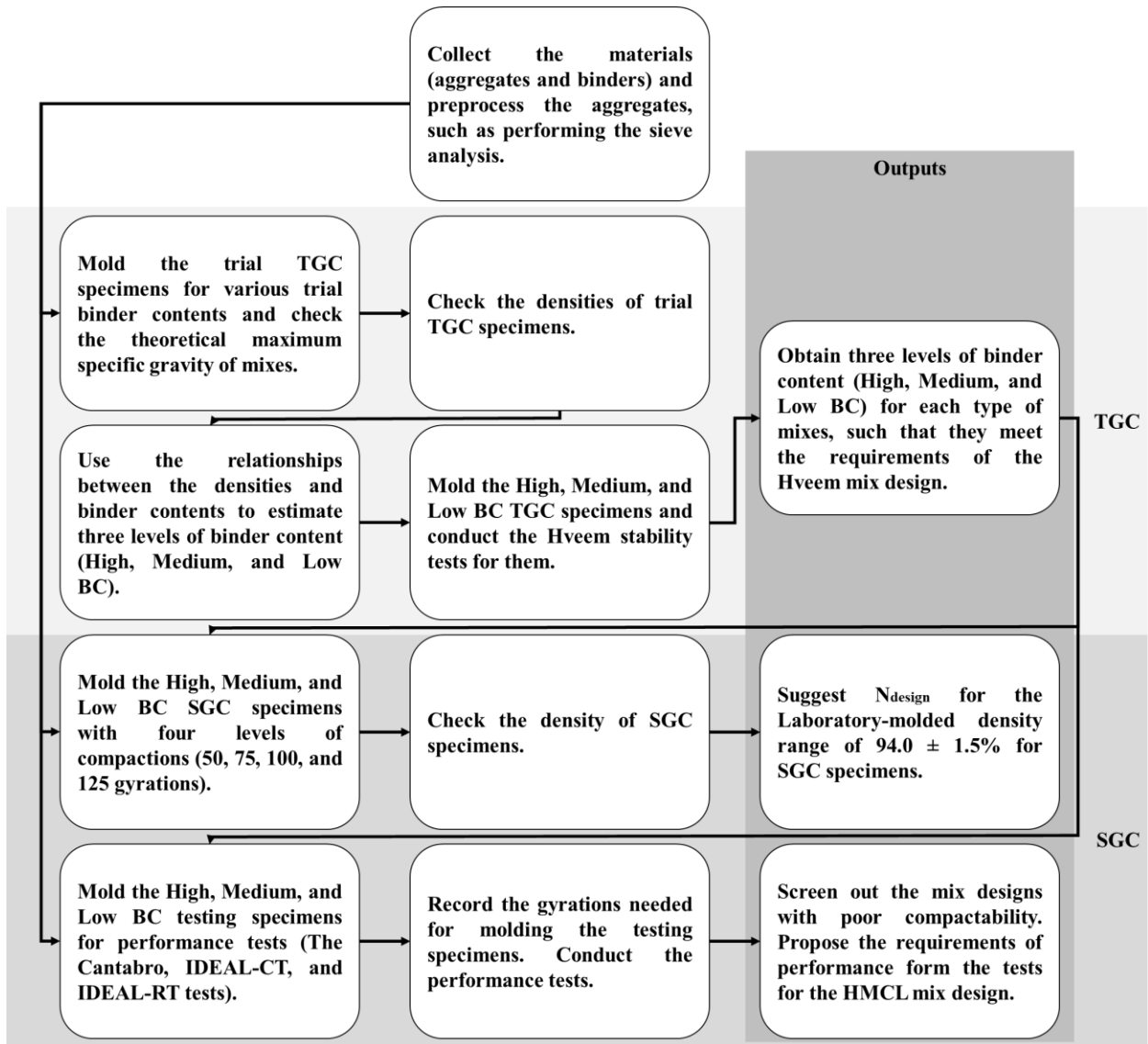

Figure 15. Flowchart of the Development of Proposed HMCL Mix Design Method.

CHAPTER 4. LABORATORY TEST RESULTS AND DISCUSSION

This chapter presents and discusses the results of the experimental tests outlined in the previous chapter to establish an HMCL mix design method using an SGC and new performance tests. It provides a detailed account of the execution of the experimental test plan and presents the test results. Furthermore, this chapter recommends a new HMCL mix design method based on the results obtained using SGC. The results of Phase I, Phase II, and Phase III from the experimental testing plan are presented, followed by a summary of the proposed mix design method.

4.1 PHASE I: PRESCREENING PERFORMANCE TESTS

This section aims to prescreen which performance tests stated in Table 8 can be adopted for common HMCL materials. This is accomplished through evaluations of test results from general HMCL mixes used by contractor agencies. As part of this process, the plant-mixed HMCL mix was subjected to a series of tests, including the HWTT, IDEAL-RT, Cantabro, IDEAL-CT, and Overlay tests. The following subsections provide a concise overview of these tests and discuss the results obtained from the performance tests conducted on the plant-mixed HMCL mix. The final selection of performance tests for the proposed HMCL mix design method is presented at the end of this section.

4.1.1 Hveem Stability Test

The Hveem Stability Test is primarily used for TGC designs for various mixes in this study but is not included in the proposed SGC mix design method. Its purpose is to evaluate the cohesion of the mix design, and it is a requirement in the TGC design, as indicated in Table 3. The test is performed when the TGC specimen is conditioned at a temperature of 60 ± 3 °C. The TGC specimens are 4.0 inches (100.0 mm) in diameter and 2.0 inches (50.0 mm) in height, as shown in Figure 16. A stabilometer, which applies a vertical load and lateral pressure to the TGC specimen, is used during the test. After a sequence of vertical loads and lateral pressure adjustments, the test primarily measures the vertical displacement of the specimen when a vertical load of 4448 ± 445 N (1000 ± 100 lb) and a lateral pressure of 689.5 kPa (100 psi) are applied. The test result (i.e., the corrected Hveem stability) can be determined by the displacement, and the stability should exceed 35 for the TGC design.



Figure 16. SGC (left), IDEAL-CT (middle), and TGC (right) Specimens.

4.1.2 Hamburg Wheel Track Test

The HWTT can indicate the performance of a mix in terms of rutting and moisture damage resistance. The test can accommodate SGC molding, where two IDEAL-CT specimens with a diameter of 150.0 mm (5.9 inches) and a height of 62.0 ± 2.0 mm (2.4 inches) are cut and joined together to form a plane for rutting, as illustrated in Figure 17.

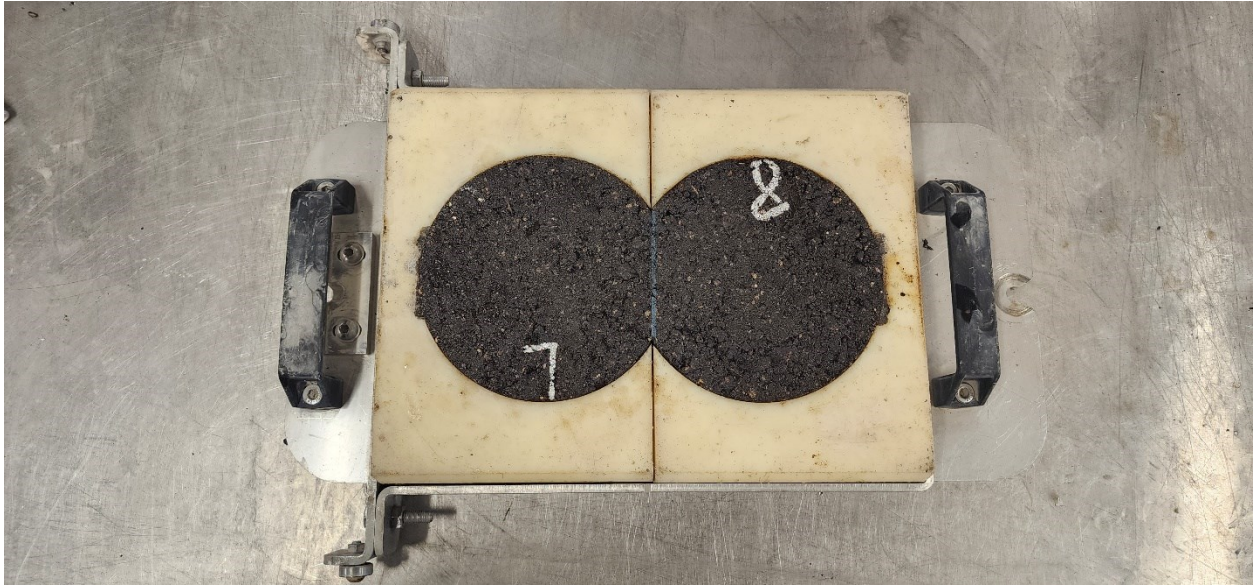

Figure 17. Specimen of HWTT.

The test is performed in a water bath maintained at a constant temperature of 50 °C. Rolling loads of 705 N are applied to the specimen during the test using a 47.0 mm wide steel wheel, as illustrated in Figure 18.

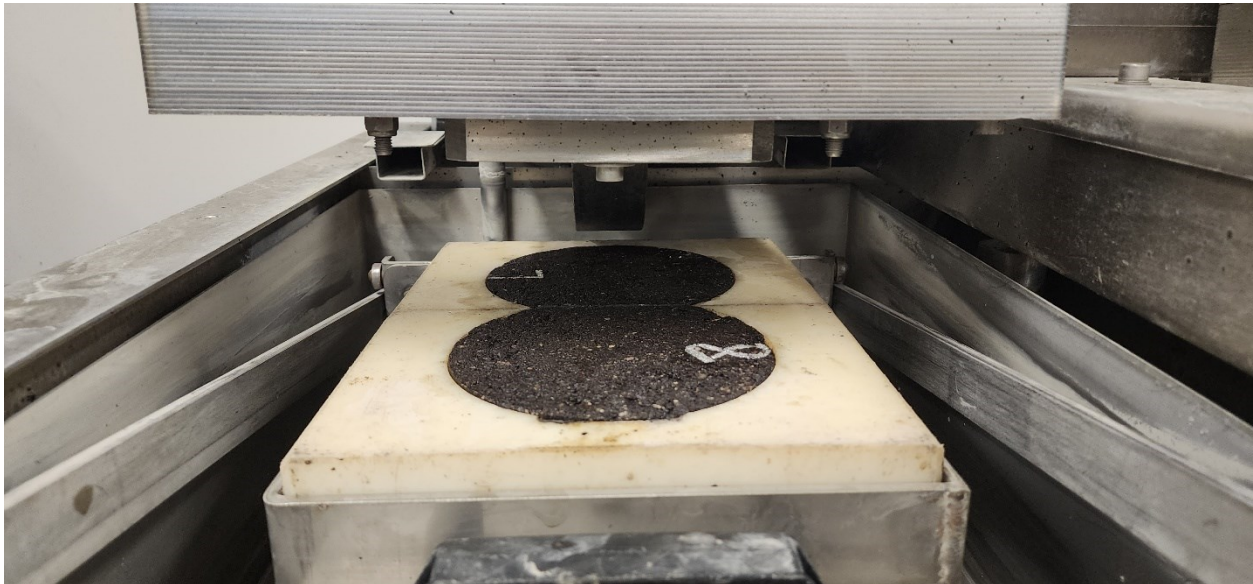

Figure 18. Setup of HWTT.

A general HMA mixture with a PG 76-22 binder is considered to have passed the test if the rut depth is less than 12.5 mm after 20,000 load passes using a rolling 47-mm-wide steel wheel with a force of 705 N. However, for the plant-mixed HMCL mix, as illustrated in Figure 19, the rut depth reaches 13.65 mm after only 1014 load passes. This indicates that the rutting resistance of a common HMCL mixture is poor compared to an HMA mixture and that the HWTT may not accurately reflect the performance of HMCL mixes. As a result, the HWTT is not selected for the

development of the HMCL mix design method, and the performance of the HMCL material's rutting resistance should be indicated by another test, such as the IDEAL-RT test.



Figure 19. Rut Depth after 1014 Load Passes.

4.1.3 IDEAL-RT Test

The IDEAL-RT Test is recently developed for the evaluation of the rutting resistance of an asphalt mixture (Zhou et al., 2019). The test adopts IDEAL-CT specimens molded by a SGC, with a diameter of 150 mm (5.9 inches), a height of 62.0 ± 2.0 mm (2.4 inches), and a density of 93.0 ± 0.5 percent. In this study, the specimens were conditioned in an air chamber with a constant temperature of 25 °C, as shown in Figure 20.

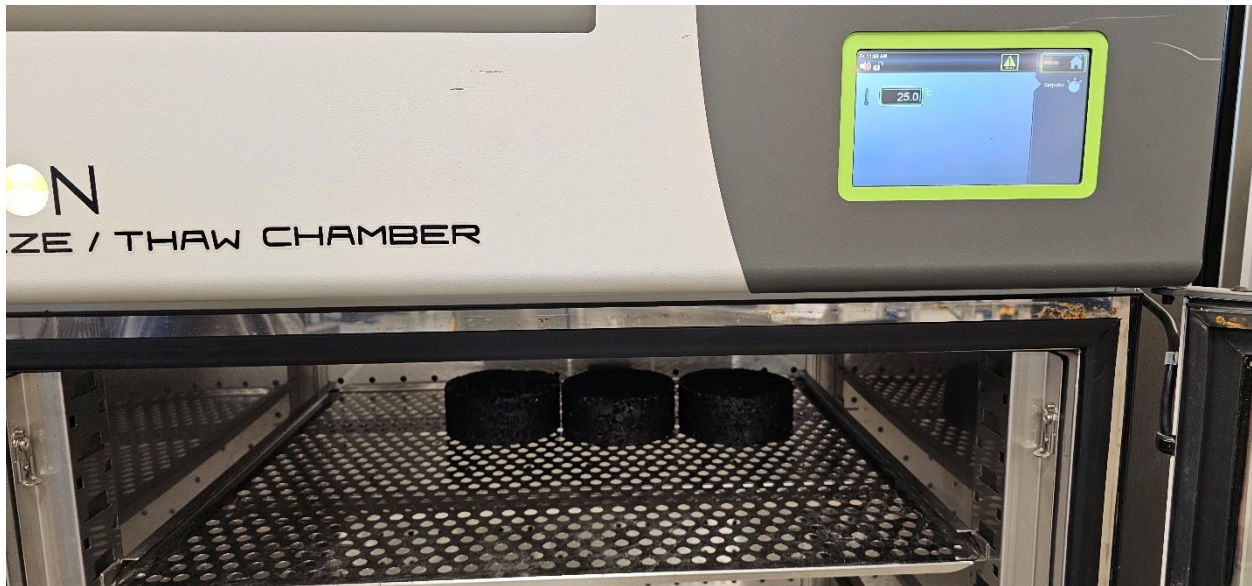

Figure 20. Conditioning of IDEAL-RT Specimens.

The test was conducted by the IDEAL-CT machine with a loading rate of 50 mm/min and an IDEAL-RT fixture, as shown in Figure 21.



Figure 21. Setup of IDEAL-RT Test.

Table 9 gives the test results (i.e., the RT-Index of the plant-mixed HMCL mix).

Table 9. IDEAL-RT Test Results of Plant-Mixed HMCL Mix.

Specimen	Height, mm	Max Load, kN	RT-Index
1	62.10	3.830	76.08
2	62.00	3.869	76.98
3	62.07	3.779	75.10
Average	62.06	3.826	76.05

As shown in Figure 22, the HMCL specimen appears soft and easily breakable after undergoing the IDEAL-RT test. Despite this, the test is still able to accurately assess the performance of the material due to its ability to record the load history and sensitivity to force. This makes it a valuable tool for evaluating even materials with weak rutting resistance, such as HMCL. As a result, the IDEAL-RT test will be incorporated into the new HMCL mix design method.



Figure 22. Specimen after IDEAL-RT Test.

4.1.4 Cantabro Test

The Cantabro Test is used to measure the raveling resistance of a mixture. The test adopts SGC specimens with a diameter of 150 mm (5.9 inches), a height of 115.0 ± 5.0 mm (4.5 inches), and a density of 93.0 ± 0.5 percent. During the test, the specimen is tumbled in a Los Angeles Abrasion machine for 300 revolutions at a rate of 30 revolutions per minute, as depicted in Figure 23.



Figure 23. Setup of Cantabro Test.

During the tumbling process, some aggregates of the specimen may disintegrate. Figure 24 shows an image of a specimen from the HMCL mix after undergoing the test.



Figure 24. Specimen after Cantabro Test.

The weight loss of a specimen after tumbling is used to measure the raveling potential of a mix design. While the weight loss can vary depending on the design of the mixture, it generally does not exceed 20 percent for common dense-graded HMA. Table 10 displays the results of the Cantabro Test for the HMCL mix, which show that the variance in weight loss is minimal and the results are comparable to those of common HMA. Based on these results, it can be concluded that the Cantabro Test is an effective tool for evaluating the performance of HMCL mixes and will be adopted in this study.

Table 10. Cantabro Test Results of Plant-Mixed HMCL Mix.

Specimen	Weight before the Test, g	Weight after the Test, g	Weight Loss, %
1	4728	4413	6.66
2	4765	4507	5.41
Average	4746.5	4460	6.04

4.1.5 IDEAL-CT Test

The IDEAL-CT Test is a standard procedure for evaluating the cracking resistance of a mix design. Similar to the IDEAL-RT Test, the test uses IDEAL-CT specimens molded by an SGC, with a diameter of 150 mm (5.9 inches), a height of 62.0 ± 2.0 mm (2.4 inches), and a density of 93 ± 0.5 percent, as well as a load with a loading rate of 50 mm/min. The specimen is placed on the IDEAL-CT fixture, as shown in Figure 25, and the test measures the force-displacement relationship as the load is applied until the specimen breaks, as illustrated in Figure 26. In this study, before testing, the specimens were conditioned in an air chamber at a constant temperature of 25 °C, as depicted in Figure 27.



Figure 25. Setup of IDEAL-CT Test.



Figure 26. Specimen after IDEAL-CT Test.



Figure 27. Conditioning of IDEAL-CT Specimens.

Table 11 displays the test results (i.e., the CT-Index of the plant-mixed HMCL mix).

Table 11. IDEAL-CT Test Results of Plant-Mixed HMCL Mix.

Specimen	Height, mm	Diameter, mm	Density, %	CT-Index
1	61.69	150.04	92.58	17.0
2	61.85	150.01	92.60	17.5
3	61.61	150.08	92.83	19.0
Average	61.72	150.04	92.67	17.83

Despite the fact that HMCL material has relatively weaker cracking resistance compared to general HMA mixtures, the test is still capable of accurately assessing the performance of HMCL mixes. As a result, the test will be incorporated into this study.

4.1.6 Overlay Test

The Overlay Test is a standard test in Texas for the evaluation of the cracking resistance of an HMA mixture. However, since the test requires cutting large portions of SGC specimens and the HMCL specimen will be easily broken during the cutting, the test will not be included in the study and the cracking resistance will be assessed by the IDEAL-CT test for HMCL mixes.

4.1.7 Selection of Performance Tests for the Proposed HMCL Mix Design Method

To summarize, the proposed method for designing HMCL mixes incorporates the Cantabro, IDEAL-CT, and IDEAL-RT tests. These tests allow for a comprehensive evaluation of the HMCL mixes' resistance to revealing, cracking, and rutting. Conversely, the HWTT and Overlay

tests are not employed in this method. This is because the HWTT may not provide an accurate reflection of the mixes' weak rutting resistance, and obtaining an HMCL test specimen for the Overlay test poses a challenge due to its tendency to fracture during multiple cuts. Furthermore, these two tests primarily assess the mixes' resistances to rutting and cracking, aspects that are already covered by the IDEAL-CT and IDEAL-RT tests.

4.2 PHASE II: HMCL DESIGNS USING THE CURRENT HVEEM MIX DESIGN METHOD

As mentioned in the experimental plan and the objectives in the introduction, the proposed mix design aims to comply with the current mix design. The proposed mix design method is thus based on a study of five types of mixes (Mix 1–5 in Table 7), each with three levels of binder content (i.e., high, medium, and low BC) determined from the current Hveem mix design method. Table 12 shows the binder contents and corresponding TGC laboratory-molded densities of these 15 mixes. These contents correspond to high, medium, and low TGC laboratory-molded densities in the range of 94.0 ± 1.5 percent (Table 2).

Table 12. Binder Contents and Corresponding TGC Laboratory-Molded Densities (Determined from TxDOT Mix Design Spreadsheet).

	Binder Content, %			Laboratory-Molded Density, %		
	Low	Medium	High	Low	Medium	High
Mix 1	4.1	4.7	5.3	92.5	94.0	95.5
Mix 2	4.3	4.7	5.3	93.1	94.0	95.5
Mix 3	4.0	4.3	4.8	93.3	94.0	95.5
Mix 4	4.0	4.3	4.8	93.4	94.0	95.5
Mix 5	2.7	3.0	3.6	92.9	94.0	95.5

To establish relationships between binder contents and corresponding TGC laboratory-molded densities, as well as theoretical maximum specific gravity (GMM), TGC specimens are molded using mixes with some trial binder contents. High, medium, and low BC are then obtained from the linear relationships between the contents and densities, as shown in Figure 28–Figure 29. Figure 30–Figure 31 display the GMM of mixes with the binder contents, where the relationships can also be estimated to be linear. Additionally, these figures demonstrate that the effects of binder types and sources on the TGC laboratory-molded densities and GMM of the mixes are negligible. Moreover, the gradation affects the binder contents determined by the TGC mix design method significantly and HMCL-B generally will have lower binder content than HMCL-D.

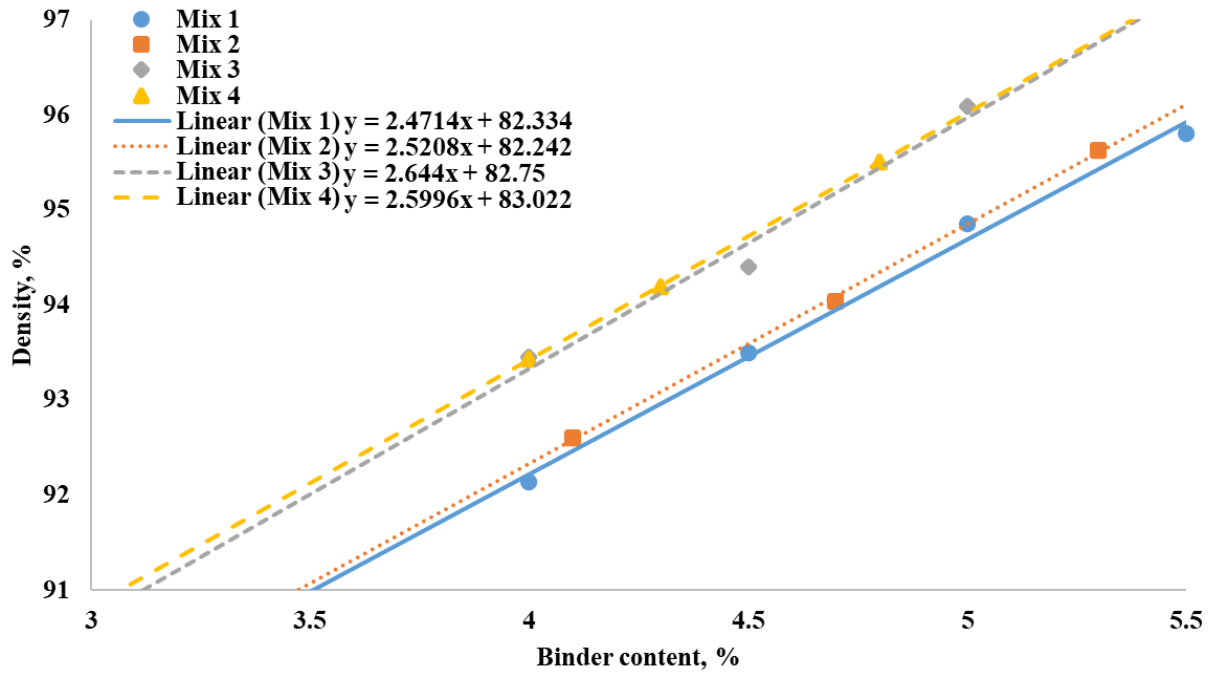

Figure 28. Relationships between Binder Contents and Corresponding TGC Laboratory-Molded Densities (Mix 1–4).

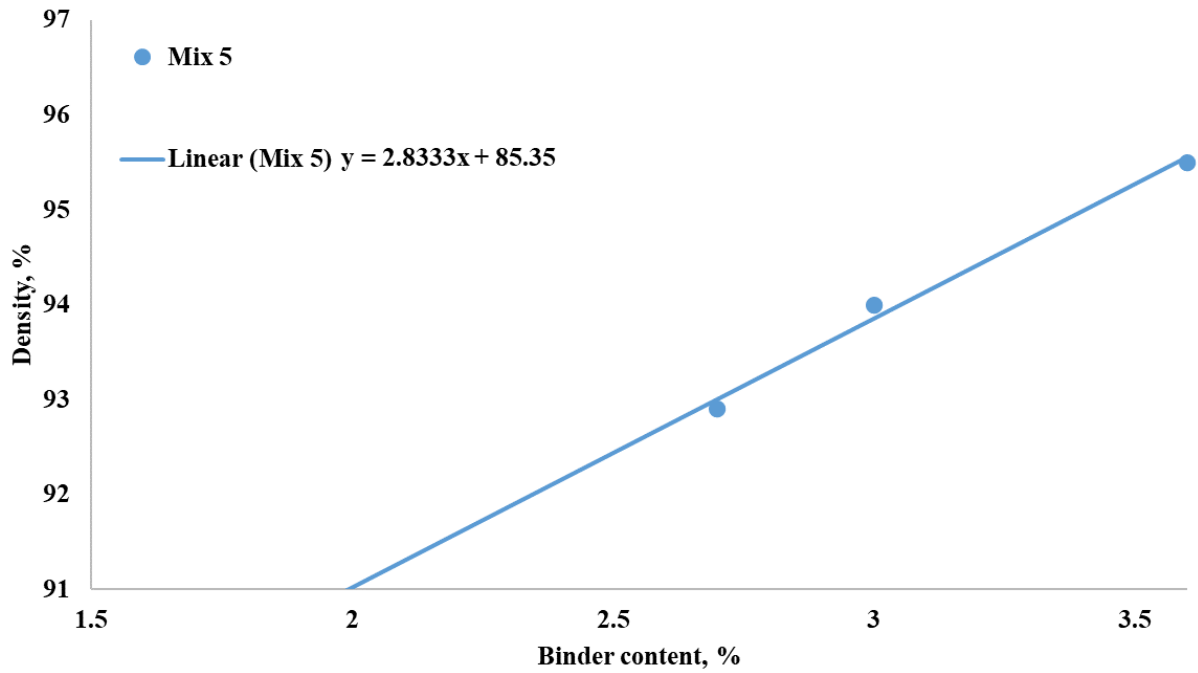

Figure 29. Relationship between Binder Contents and Corresponding TGC Laboratory-Molded Densities (Mix 5).

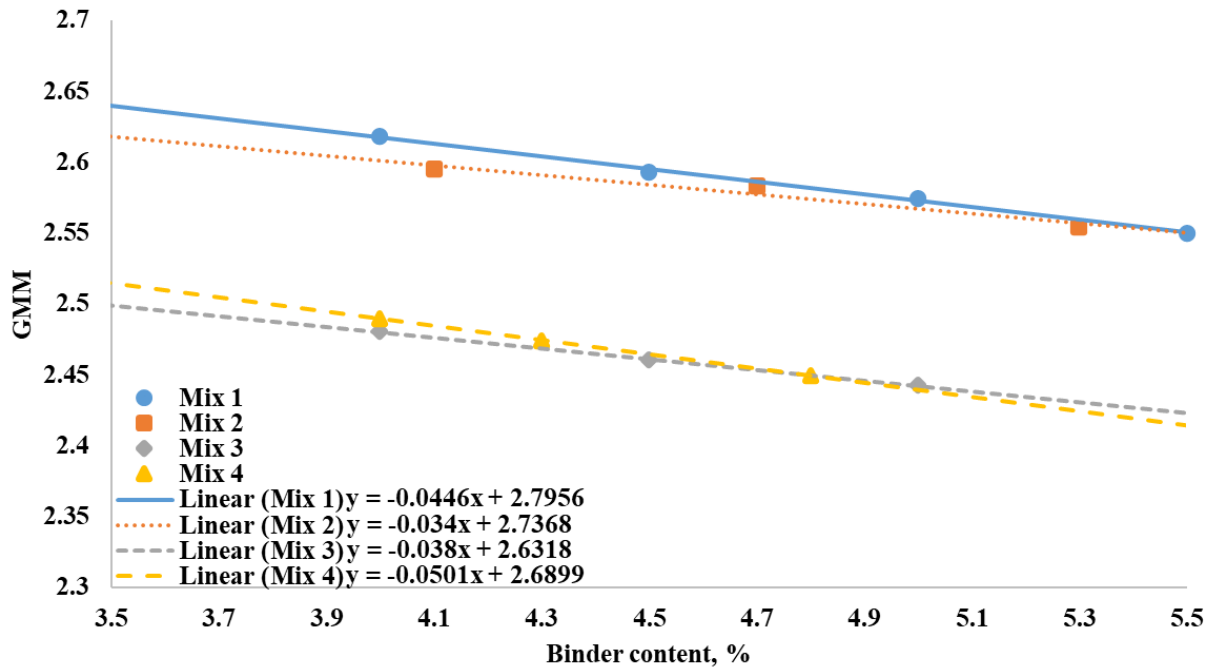

Figure 30. Relationships between Binder Contents and Corresponding TGC Laboratory-Molded Densities (Mix 1–4).

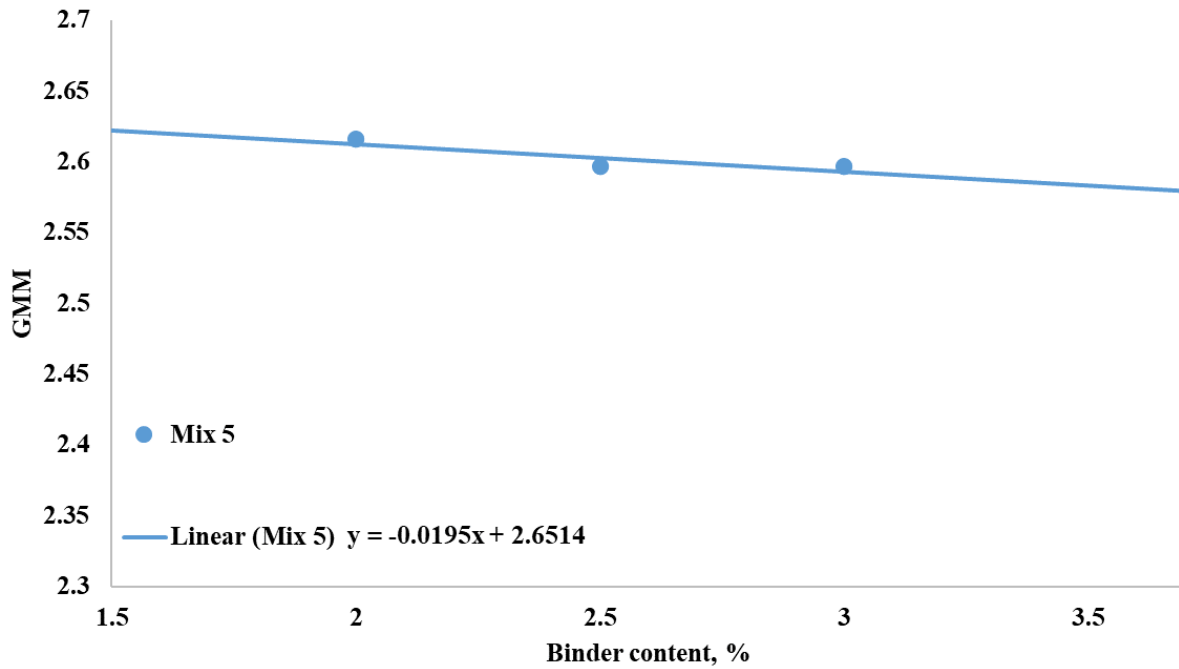

Figure 31. Relationship between Binder Contents and Corresponding TGC Laboratory-Molded Densities (Mix 5).

According to TxDOT specification Item 334, as shown in Table 2, HMCL materials should have a Hveem stability greater than 35.0 (Item 334, 2014). To comply with this specification, Hveem stability tests are conducted on all 15 mixes, and the results are presented in Figure 32.

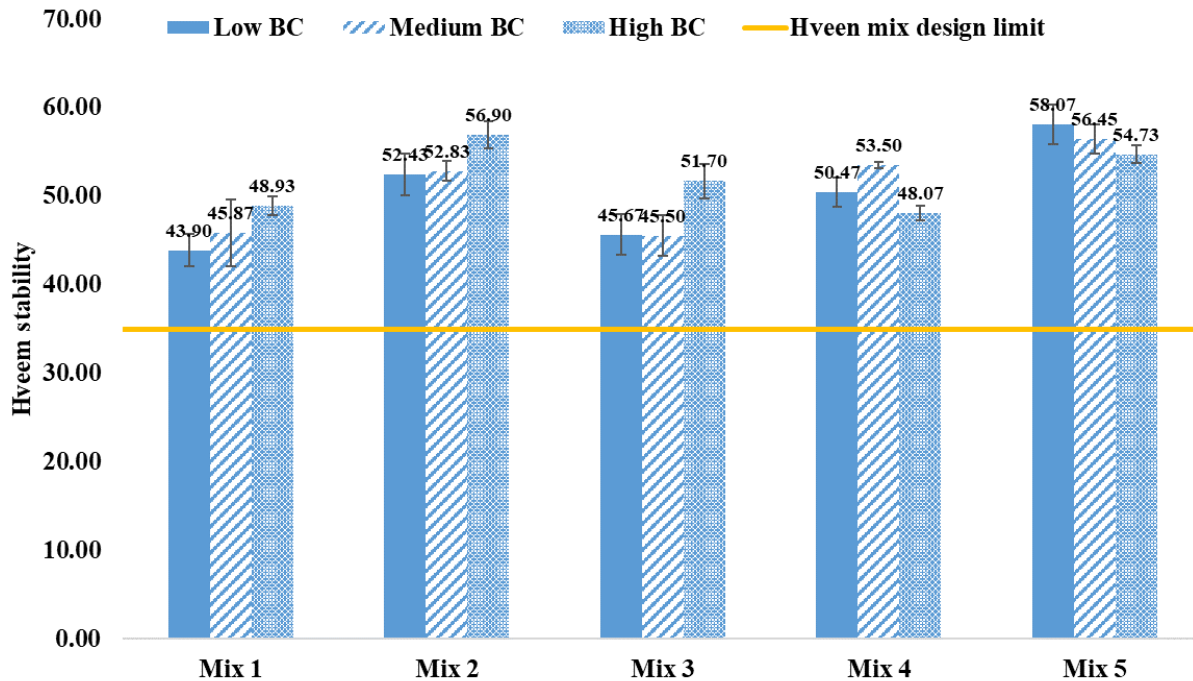

Figure 32. Results of Hveem Stability Tests.

All mixes in the study have a Hveem stability greater than 35.0, indicating that the current Hveem mix design method accepts mixes with low binder contents and poor compactability. Although Hveem stability generally increases with increasing binder content, the increase is not significant, with changes of less than 10 percent. When comparing limestone and gravel mixes using the same binder and binder content level (Mix 2 and Mix 3), the stabilities of the gravel mixes are generally lower than those of the limestone mixes, in agreement with the previous study (Estakhri et al., 1999a, 1999b). Moreover, the HMCL-B design generally has better stability than the HMCL-D design. However, the differences between them are not as clear as in the previous results, suggesting that Hveem stability is not always sensitive to mix designs.

4.3 PHASE III: DEVELOPMENT OF THE PROPOSED HMCL MIX DESIGN METHOD

In order to align with the existing Hveem mix design, SGC specimens are molded for each laboratory-mixed HMCL mix with various compaction levels (i.e., 50, 75, 100, and 125 gyrations) to determine the N_{design} value for SGC laboratory-molded densities in the range of 94.0 ± 1.5 percent. Performance tests selected from Phase I (Cantabro, IDEAL-CT, and IDEAL-RT tests) are then conducted on all mixes to evaluate their compactability and performance, helping to develop standards for the proposed mix design method. According to Table 2, the

Hveem mix design method stipulates that the Hveem stability of TGC specimens molded from HMCL mixes exceeds 35 in addition to meeting the laboratory-molded density requirement. However, as shown in Phase II, the stability is not always sensitive to binder content, making it challenging to correlate test results with performance. Therefore, besides determining N_{design} to replace TGC with SGC for mix design, this study also aims to replace the Hveem stability test with performance tests that are easy to use and closely related to field performance for the mix design. The Cantabro test, IDEAL-CT test, and IDEAL-RT test at 25 °C are adopted for this purpose.

The TGC laboratory-molded densities specified in the current version (94.0 ± 1.5 percent, as stated in the specification SP334-003 effective January 2022 letting, statewide use) are significantly higher than those in the previous version (92.5 ± 1.5 percent) (SP334-003, 2021). Densities generally increase as binder contents increase, indicating that higher binder contents are recommended for HMCL mixes nowadays. While an increase in binder contents should enhance mix compactability, as demonstrated in the subsequent subsection, the current specification may still result in low compactability. Therefore, another goal of this research is to study the effects of binder contents on mix compactability. The compactability of mixes is indicated by the number of gyrations required to mold specimens for performance tests, with more gyrations implying lower compactability and helping to screen out poor mix designs.

Therefore, the compactability of the mixes, determination of N_{design} , and results of the performance tests are discussed in the following sections.

4.3.1 Requirement for the Compactability of the Mixes

The compactability of the mixes is evaluated by preparing specimens for performance tests. The compactability is determined by the gyrations of SCG compactions during the molding of IDEAL-CT and Cantabro specimens. IDEAL-CT specimens are cylindrical, with a diameter of 150.0 mm (5.9 inches), a height of 62.0 ± 2.0 mm (2.4 inches), and a density of 93.0 ± 0.5 percent, which is the same as IDEAL-RT specimens. Cantabro specimens are also cylindrical, with a diameter of 150.0 mm (5.9 inches), a height of 115 ± 1.0 mm (4.5 inches), and a density of 93.0 ± 0.5 percent. Figure 33 and Figure 34 show the gyrations during the molding of IDEAL-CT and Cantabro specimens, respectively.

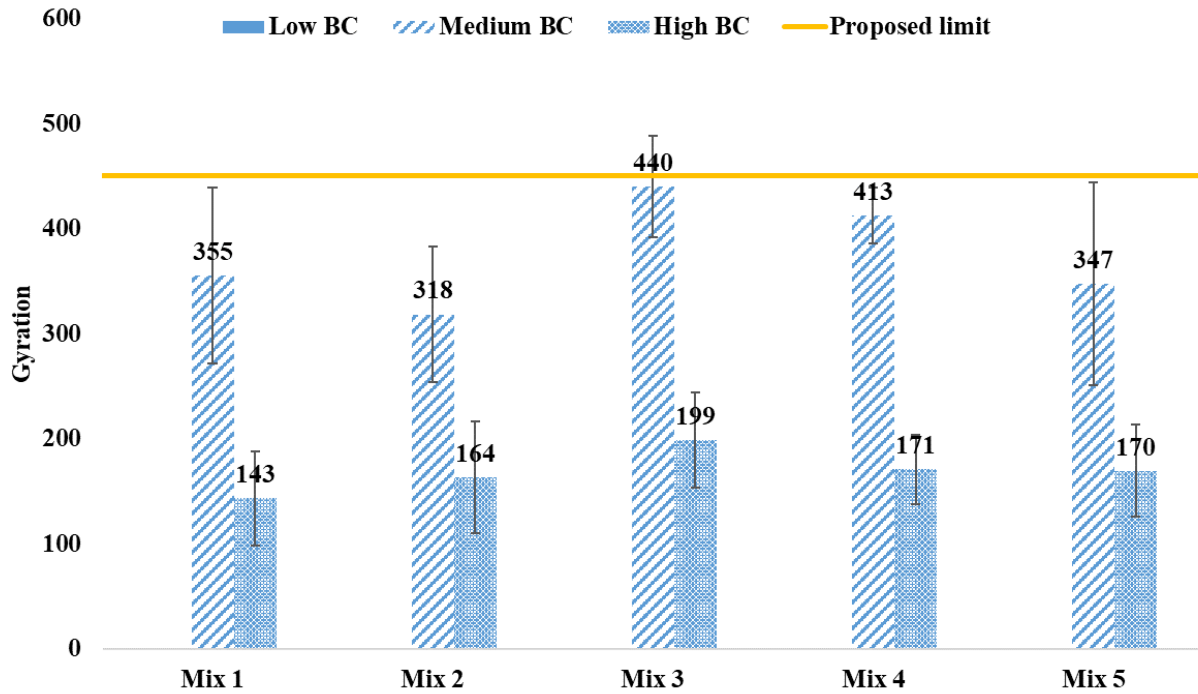

Note: Specimens of mixes with low BC failed to be prepared within 450 gyrations and thus are not shown.

Figure 33. Gyrations of SCG Compactions in Molding IDEAL-CT Specimens.

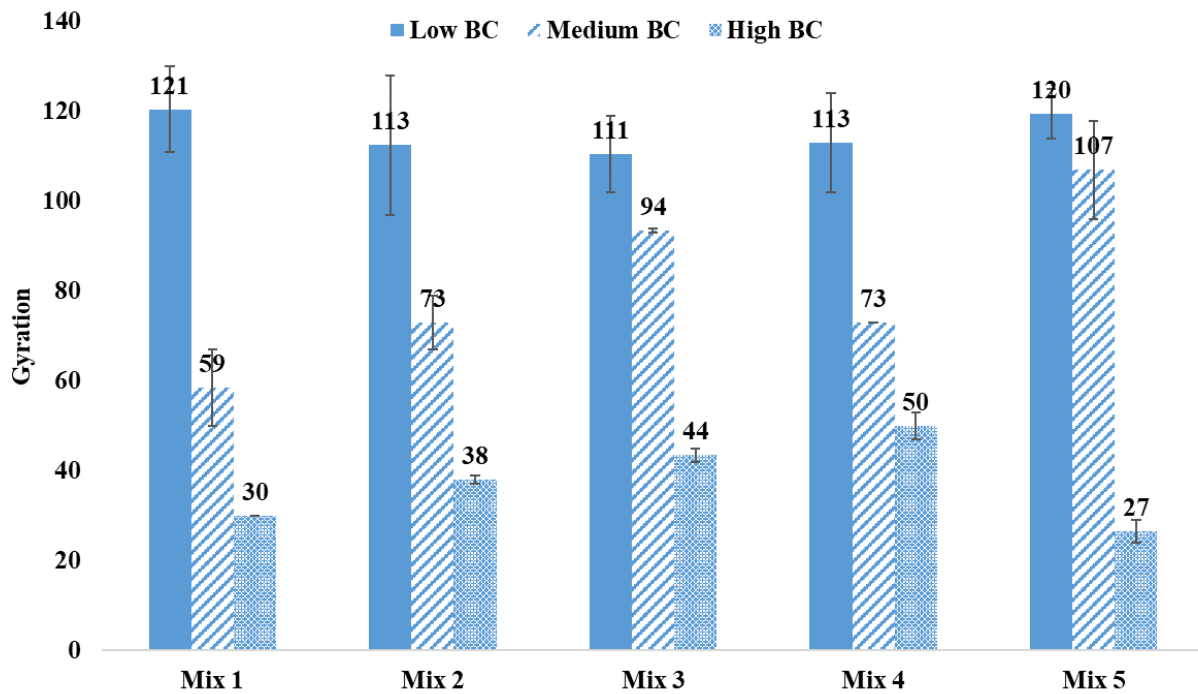

Figure 34. Gyrations of SCG Compactions in Molding Cantabro Specimens.

Since all specimens have densities around 93.0 percent, it can be concluded from the figures that a larger volume and higher binder content can reduce the number of gyrations needed for compaction. Therefore, HMCL mixes with lower binder contents exhibit poor compactability,

making it difficult to mold small specimens. Specifically, all IDEAL-CT specimens of HMCL mixes with low BC cannot be molded within 450 gyrations. The temperature change along the gyration of an HMCL mix (Mix 5 with low BC) under the SGC compaction for preparing an IDEAL-CT specimen is illustrated in Figure 35. Since the compaction temperature normally drops to approximately 45 °C after 15 minutes (equivalent to 450 gyrations) in molding IDEAL-CT specimens, it becomes impossible to generate the specimens from these mixes with low BC. Hence, their gyrations are not shown in Figure 33. Moreover, the mixes with medium BC have gyrations of 300–500 in Figure 33, which means that they are already difficult to compact and generate IDEAL-CT specimens. Since the IDEAL-CT test is a common test to indicate the cracking resistance of the asphalt mixture and asphalt mix should be compactable for the test, this study should screen out those dry mixes without enough binder contents. In other words, mixes with laboratory-molded densities of less than 94.0 percent in the current Hveem mix design method have low compactability and should not be accepted.

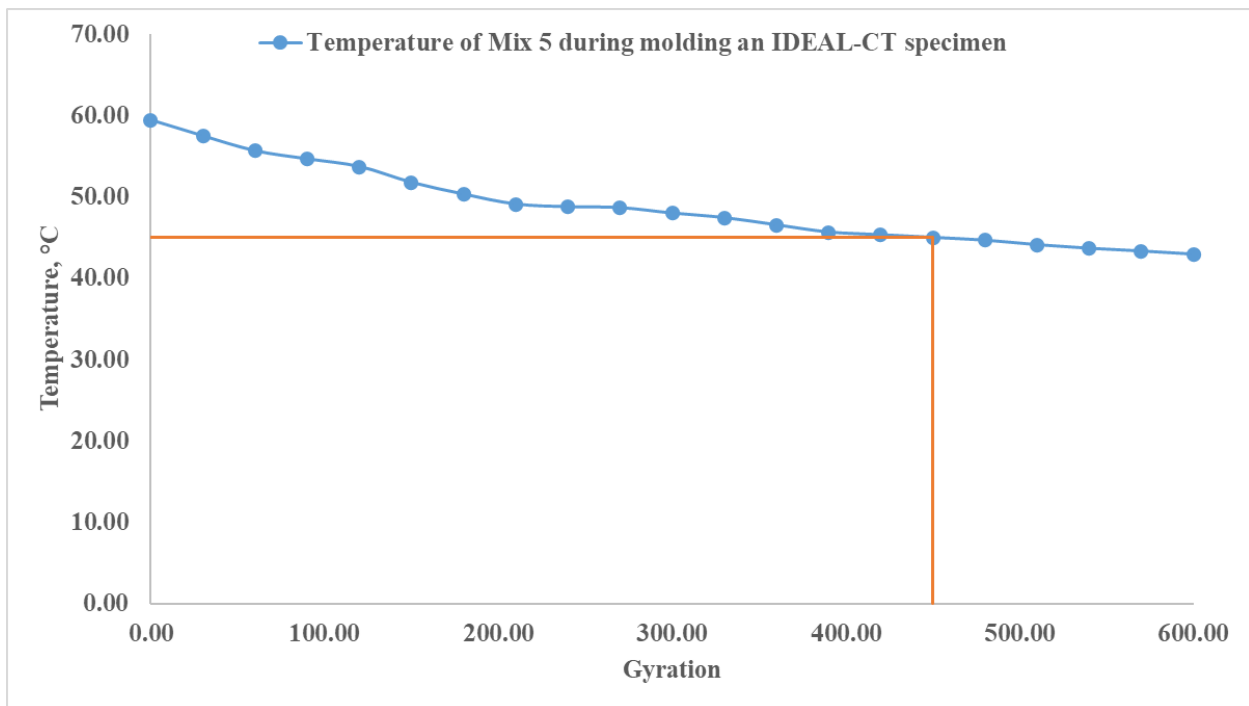

Figure 35. Temperature Change along Gyration of an HMCL Mix (Mix 5 with low BC) for Preparing an IDEAL-CT Specimen.

4.3.2 Determination of N_{design}

To develop a mix design method for HMCL materials using an SGC, the N_{design} and SGC laboratory-molded density should be established. To keep the change as minimal as possible, the chosen SGC laboratory-molded density is within the range of 94.0 ± 1.5 percent, which is the same as the current Hveem mix design method based on the specification Item 334. N_{design} can be determined by analyzing the relationship between laboratory-molded densities and compaction

levels of SGC specimens. Figure 36–Figure 38 show the relationships for limestone mixes (Mixes 1–2), gravel mixes (Mixes 3–4), and Mix 5.

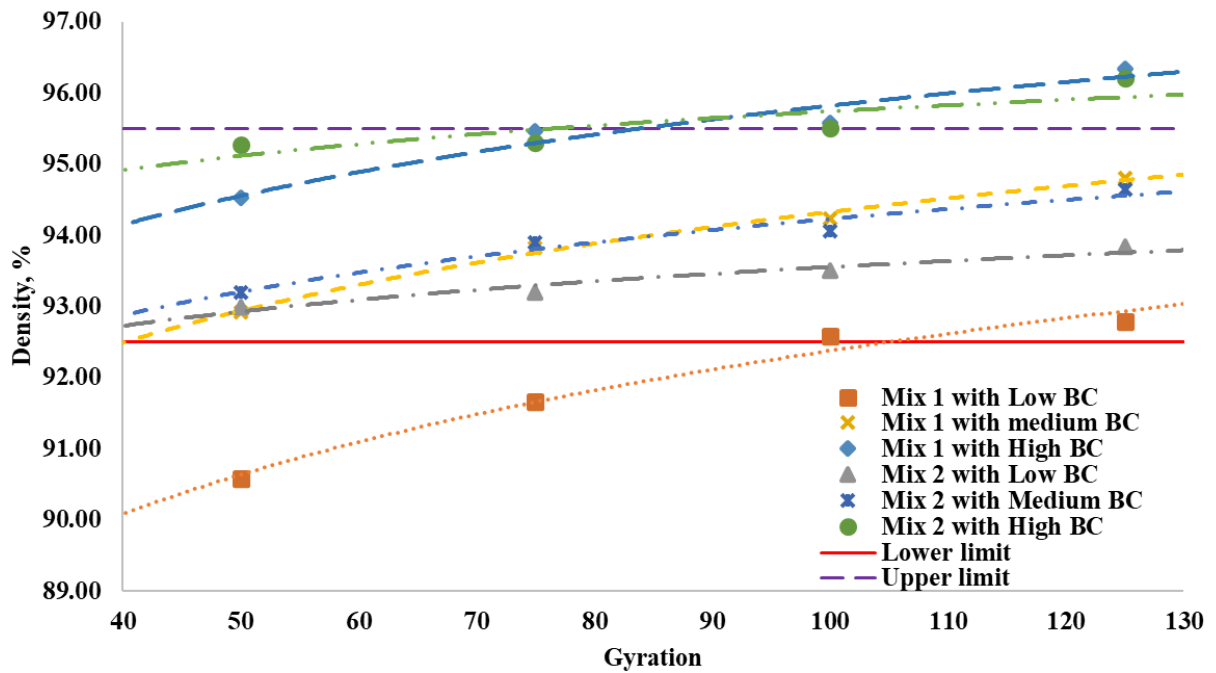

Figure 36. Relationships between SGC Laboratory-Molded Densities and Gyration of Limestone Mixes (Mix 1 and Mix 2).

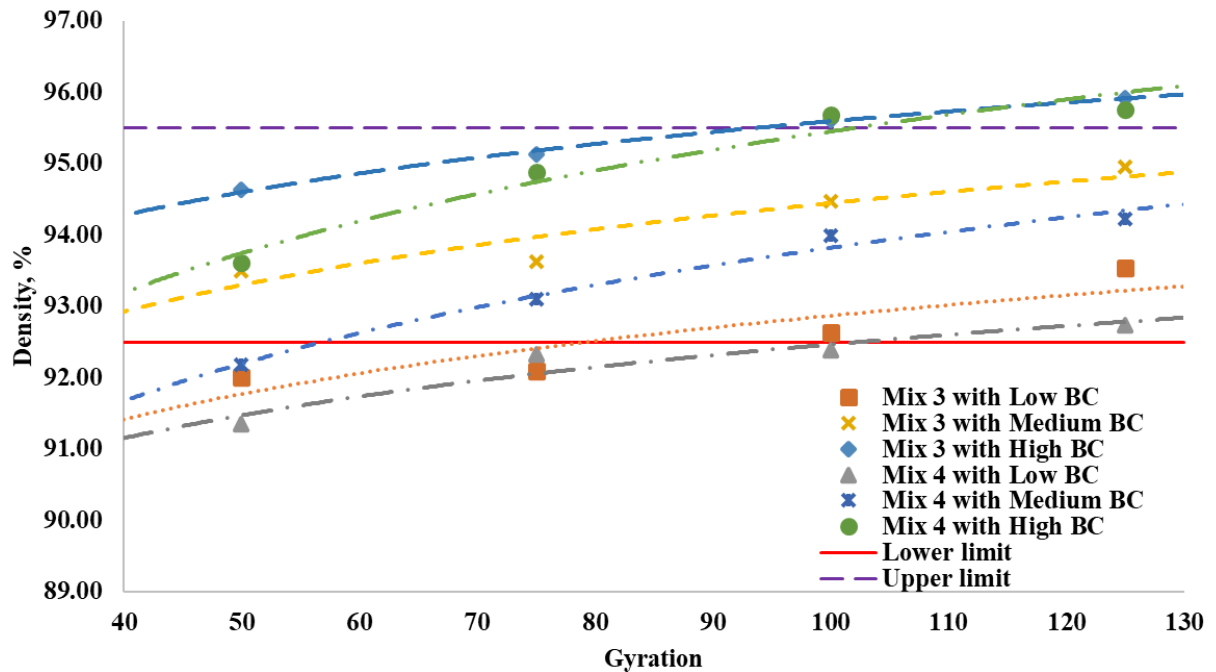

Figure 37. Relationships between SGC Laboratory-Molded Densities and Gyration of Gravel Mixes (Mix 3 and Mix 4).

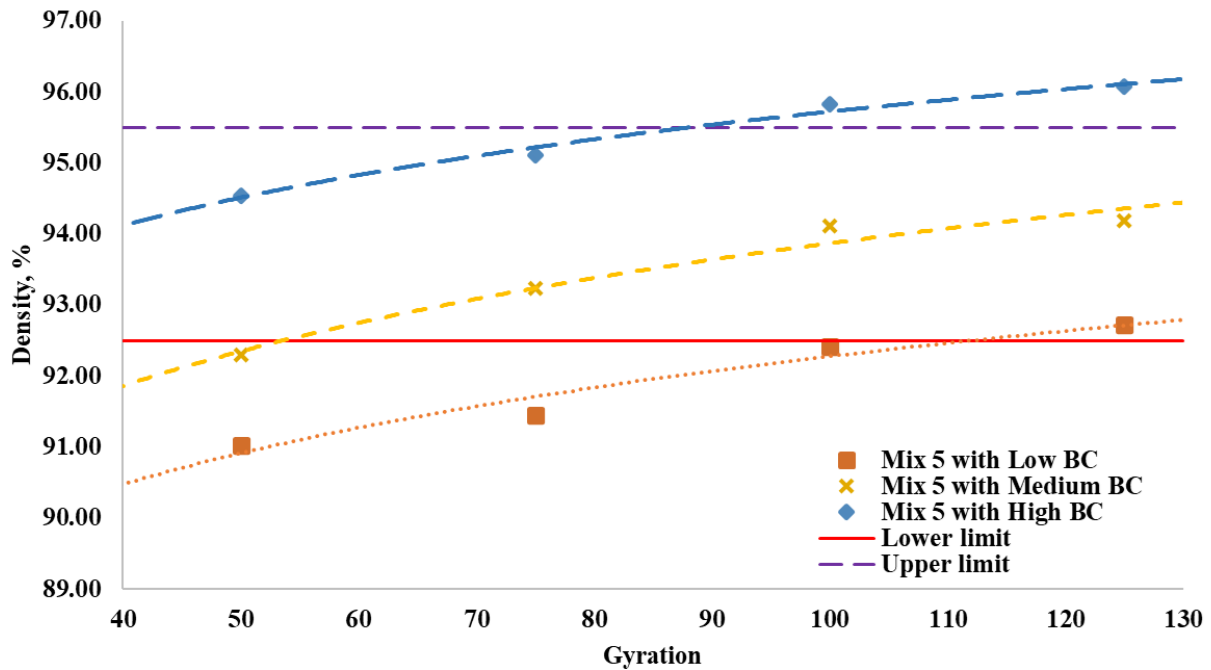

Figure 38. Relationships between SGC Laboratory-Molded Densities and Gyration of Mix 5.

The figures show that for the compaction level of 75 gyrations, almost all the mixes with low BC except Mix 2 have laboratory-molded densities lower than the lower limit of 92.5 percent. Moreover, the densities of other mixes at this compaction level are within the prescribed range of 94.0 ± 1.5 percent. Furthermore, the figures show that at the compaction level of 75 gyrations, the laboratory-molded densities for mixes of the same types of aggregates and the same binder contents are very similar (excluding Mix 1 and 2 with low BC since they have different binder contents). In other words, the effects of binder types and sources on compaction are slight compared with those of aggregate types. Figure 39 shows the linear regressions used for the relationships between binder contents and the densities of limestone and gravel mixes at the compaction level of 75 gyrations.

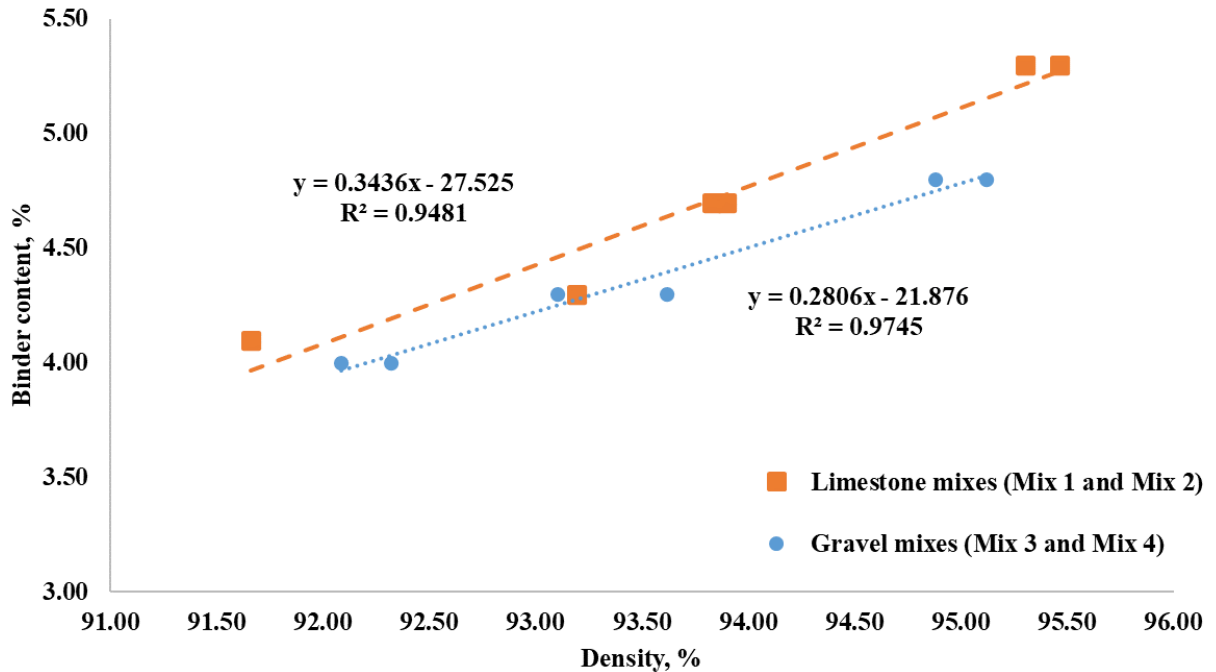

Figure 39. Relationships between Binder Contents and SGC Laboratory-Molded Densities at a Compaction Level of 75 Gyration.

Consequently, from the linear relationships in Figure 39, it can be concluded that if the N_{design} is set to 75 and the laboratory-molded density is set to be in the range of 94.0 ± 1.5 percent, then the allowable binder contents for limestone mixes and gravel mixes are 4.3–5.3 percent and 4.1–4.9 percent (corresponding to TGC laboratory-molded densities in the ranges of 93.0–95.5 percent and 93.6–95.7 percent), respectively. This effectively filters out low binder contents, which lead to poor compactability.

4.3.3 Requirements for Performance Test Results

The Cantabro, IDEAL-CT, and IDEAL-RT tests are performed on the mixes, and the results are presented in Figure 40 through Figure 42.

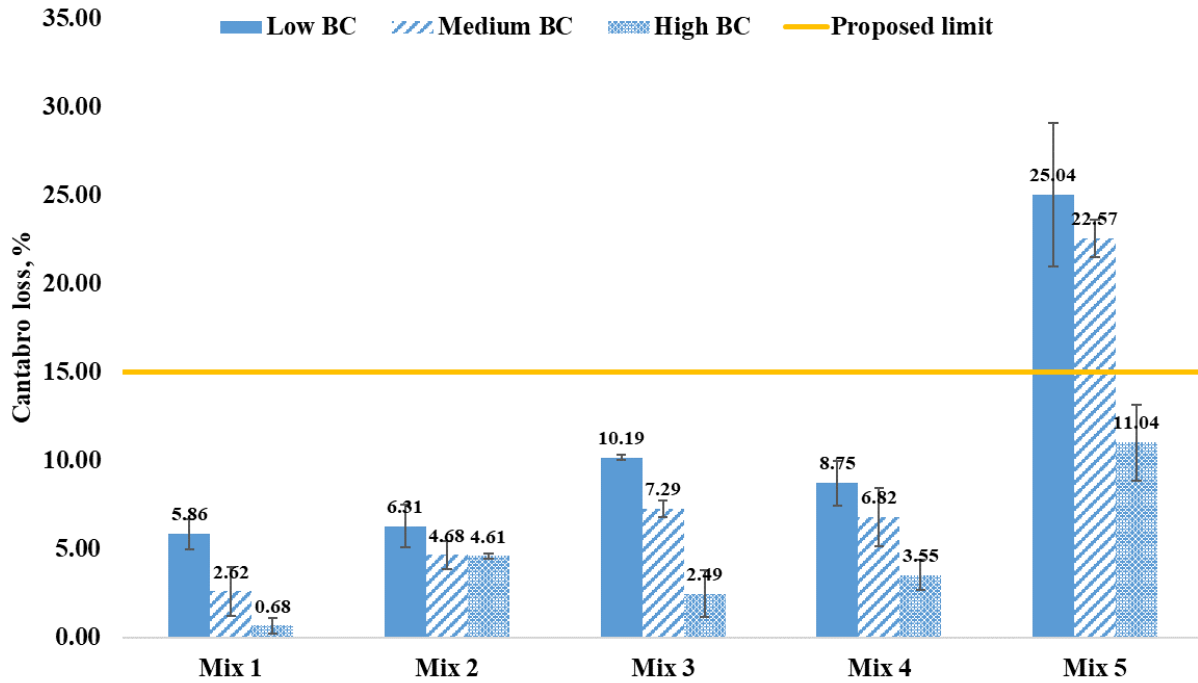
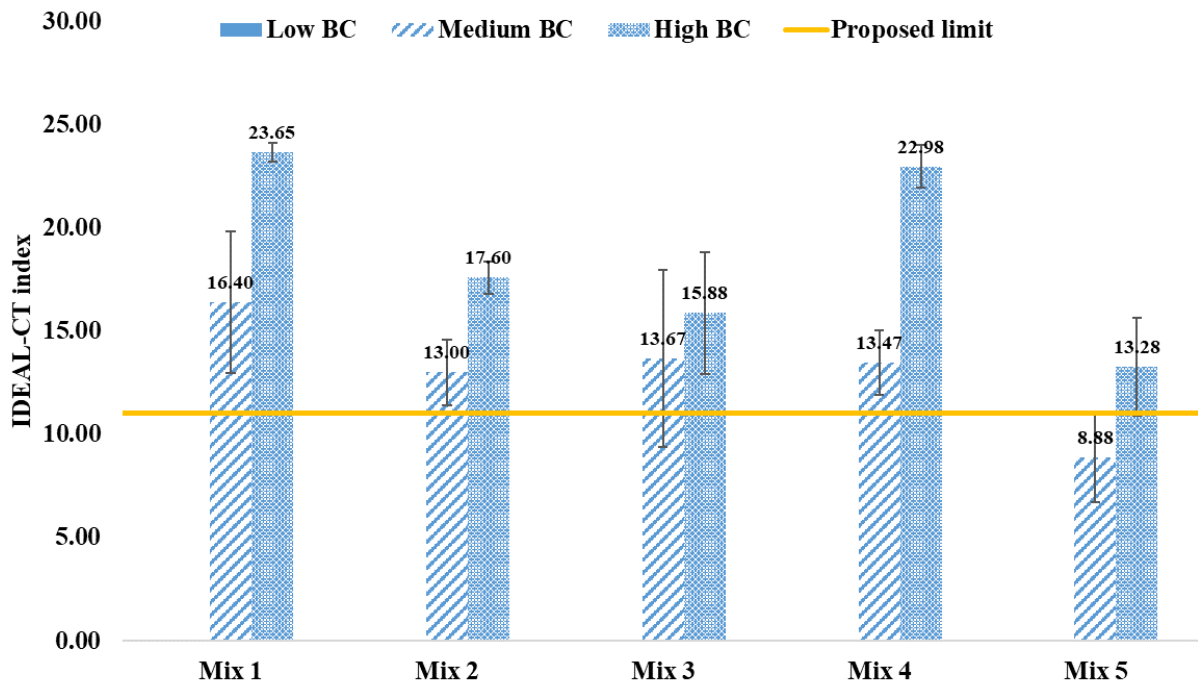
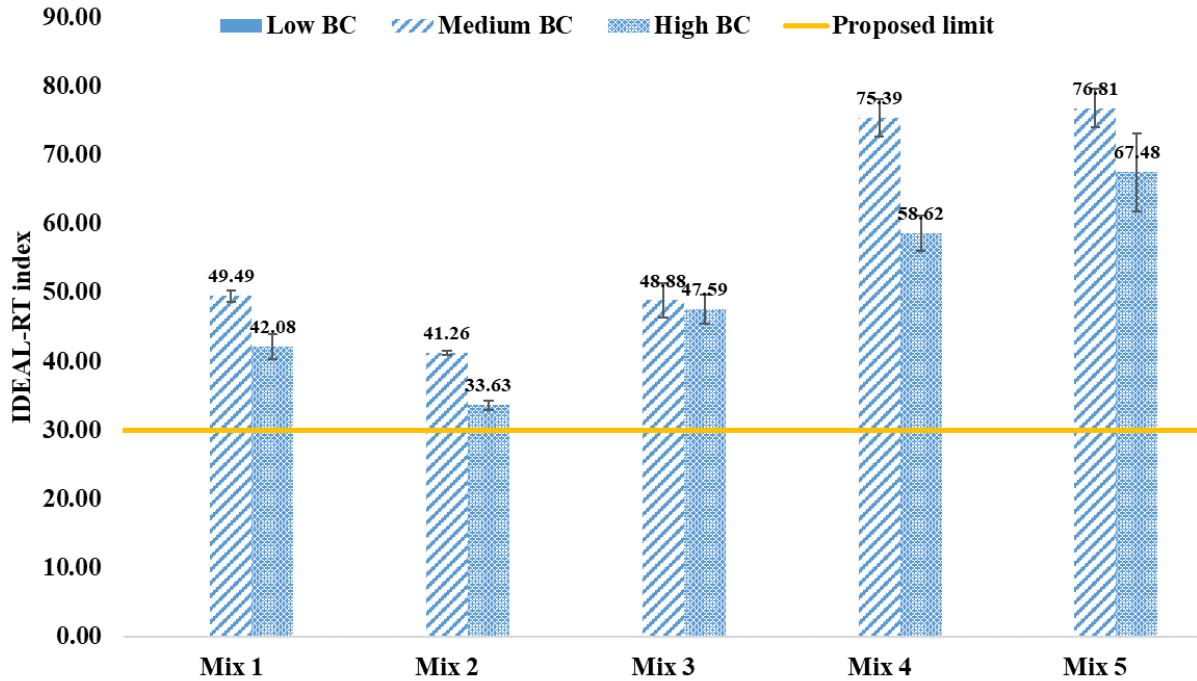

Figure 40. Results of Cantabro Tests.



Note: Results of mixes with low BC are not shown since their compactability is low and the specimens cannot be molded.

Figure 41. Results of IDEAL-CT Tests.



Note: Results of mixes with low BC are not shown since their compactability is low and the specimens cannot be molded.

Figure 42. Results of IDEAL-RT Tests.

The following observations can be made from the results:

- The Cantabro test shows better performance for the HMCL-D design compared to the HMCL-B design. This can be expected since the HMCL-B design is coarser and the large aggregates are easily lost in the test.
- As indicated by the TGC and SGC densities of various mixes, binder sources and types may not significantly affect compaction. However, they do influence performance. For instance, the binder from the binder supplier 1 provides better resistance to cracking and rutting than the binder from the binder supplier 2, while the AC-1.5 binder significantly improves rutting resistance compared to AC-0.6 binders.
- With an increase in binder contents, the performance from the Cantabro tests and IDEAL-CT tests generally improve, while those from the IDEAL-RT tests degrade. Therefore, raising binder contents can enhance the raveling and cracking resistance of HMCL mixes but at the expense of rutting resistance.
- The results of the proposed tests are more sensitive to binder contents than those of the Hveem stability test. The former's results are generally altered by more than 15 percent when binder contents are changed, while those variations from the latter are often less than 10 percent.
- The IDEAL-CT and RT indices of HMCL specimens should generally be lower than those of common HMA mixes due to the balance of performance and workability.

It is crucial to reemphasize that all mixes with low BC exhibit poor compactability, as detailed in Section 4.3. Additionally, the Cantabro test results indicate that the HMCL-B mix (Mix 5) shows insufficient raveling resistance, even when medium BC is applied. This resistance can be significantly enhanced by using high BC. Consequently, all mixes with low BC and Mix 5 with medium BC are considered unsuitable. To exclude these mixes and retain the rest, a maximum limit of 15.0 percent is established for Cantabro loss in the proposed mix design method. The method should also take into account the mixes' resistance to cracking and rutting, hence minimum limits of 11.0 and 30.0 are set for the IDEAL-CT and RT indices, respectively. These proposed limits are also applicable to general HMCL mixes, such as the plant-mixed HMCL mix, as evidenced by its test results in Section 4.1.

It is noteworthy that the laboratory-mixed HMCL mixes' test results generally show an increase in the IDEAL-CT index as Cantabro loss decreases, as depicted in Figure 43. This may imply the cracking resistance is closely related to the revealing resistance. Given the desire to minimize the number of tests for a mix design method, this observation can be utilized. A log-linear model is proposed to represent the relationship between the Cantabro and IDEAL-CT test results of the HMCL mixes, as shown in Figure 43. It is evident that when an HMCL mix's Cantabro loss is below 15.0 percent, its IDEAL-CT index will typically exceed 11.0. Therefore, the IDEAL-CT index requirement mentioned earlier can be substituted by the Cantabro loss requirement, allowing for the omission of the IDEAL-CT test in the proposed HMCL mix design method.

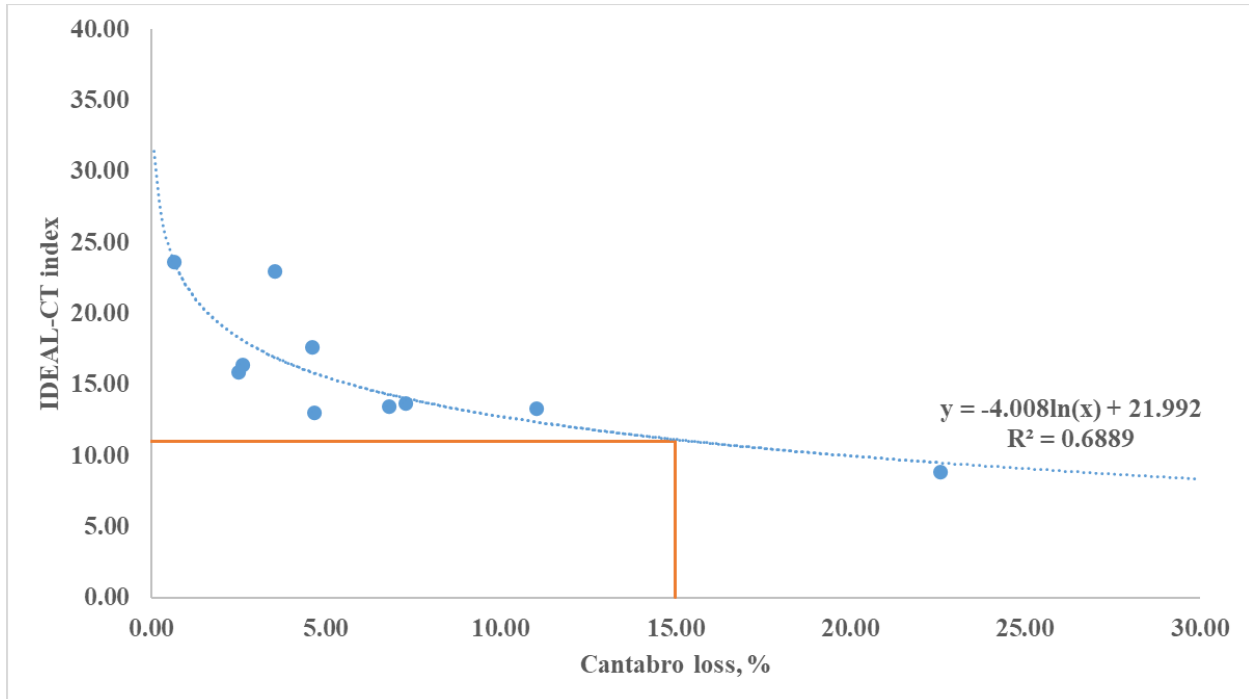

Figure 43. Relationship between Results of Cantabro and IDEAL-CT Tests.

4.4 SUMMARY OF THE PROPOSED HMCL MIX DESIGN METHOD

The proposed mix design requirements are summarized in Table 13.

Table 13. HMCL Property Requirements in Proposed Mix Design.

Property	Test Method	Requirement
Target SGC laboratory-molded density, %	Tex-207-F	94.0 ± 1.5
Cantabro loss, %	Tex-245-F	< 15.0
IDEAL-RT index at 25 °C	ASTM D8360	> 30.0
Gyrations for molding IDEAL-RT specimens	ASTM D8360	< 450

CHAPTER 5. SUMMARY AND CONCLUSIONS

Due to the several well-known and mentioned advantages of SGC, this study aimed to replace TGC with SGC in the new HMCL mix design method. Furthermore, through the investigation of several HMCL mixes designed following TxDOT specification item 334, the following defects were found:

- Despite TxDOT increasing the required TGC laboratory-molded density in its specification, binder contents determined from a low TGC laboratory-molded density may still be insufficient, resulting in poor compactability.
- The Hveem stability test is sometimes not sensitive enough to binder content to accurately reflect performance correspondence.

Therefore, this study proposes a new HMCL mix design method that utilizes an SGC, taking into account the compactability and field performance of the mixes. The new design method was developed based on performance evaluation of 15 representative laboratory-mixed HMCL mixes designed with the current Hveem mix design method. The testing process led to the following observations:

- The influence of binder sources and grades on laboratory-molded densities is relatively minor when compared to that of aggregates.
- For similar levels of laboratory-molded densities, HMCL-D aggregates generally require more binder contents than HMCL-B aggregates.
- The HWTT and Overlay test are not suitable methods for evaluating the performance of HMCL materials.
- The IDEAL-CT and RT indices of HMCL specimens are generally lower than those of standard HMA mixes due to the soft binders (AC1.5 and AC0.6) used for HMCL.
- The Cantabro test demonstrates better performance for the HMCL-D design as opposed to the HMCL-B design.
- The binder source and grade significantly impact performance. For example, AC0.6 from Supplier 1 offers better resistance to cracking and rutting than the binder from that of Supplier 2, while the AC-1.5 binder markedly enhances rutting resistance in comparison to AC-0.6 binders.
- An increase in binder content generally results in improved performance in Cantabro tests and IDEAL-CT tests, while performance in IDEAL-RT tests tends to deteriorate. Thus, increasing binder contents can improve the raveling and cracking resistance of HMCL mixes at the cost of rutting resistance.
- The results of the proposed tests are more sensitive to changes in binder contents than those of the Hveem stability test. The former's results typically change by more than 15 percent when binder content levels are altered, while variations in the latter are often less than 10 percent.

- The existing HMCL mix design method may result in mixes that have insufficient binder content for compaction, thereby making it challenging to generate the IDEAL-CT specimens at a compaction temperature of 140 °F (60 °C).

Informed by the data derived from 15 HMCL mixes, the new mix design method establishes requirements for the SGC laboratory-molded density, the minimum performance of the mix as determined by the Cantabro and IDEAL-RT tests, and the maximum gyration for molding IDEAL-RT specimens, as outlined in Table 13. The requirement for the SGC laboratory-molded density is designed to align with the existing mix design method, while the requirements for the test results aim to ensure adequate field performance in terms of resistance to raveling, cracking, and rutting. It is also crucial to note that the mixes must exhibit sufficient compactability to mold all testing specimens, particularly for IDEAL-RT specimens at a compaction temperature of 140 °F (60 °C).

The tests used are widely accepted in the United States and simple to conduct. They evaluate the resistance of mixes to raveling, cracking, and rutting. The cracking resistance performance, as determined by the IDEAL-CT test, can be inferred from the Cantabro test results, thereby rendering the IDEAL-CT test unnecessary. The test results of the HMCL mixes in this study reveal a distinct correlation between binder content and performance. Moreover, the recommended values in Table 13 can assist in eliminating mixes with inadequate binder content and poor compactability from the existing mix design. Consequently, the proposed mix design method enhances the current HMCL mix design by improving compactability and performance correspondence.

APPENDIX A. REVISED SPECIFICATION FOR ITEM 334

Revised Item 334

Hot-Mix Cold-Laid Asphalt Concrete Pavement



1. DESCRIPTION

Construct a cold-laid pavement layer consisting of a compacted mixture of aggregate and asphalt material mixed hot in a mixing plant.

This Item governs mixtures designed for cold placement, defined as placement temperatures below 175°F. If the mixture placement temperature is greater than 175°F, then design, produce, place, and compact the mixture in conformance with the applicable hot-mix asphalt specification.

2. MATERIALS

Furnish uncontaminated materials of uniform quality that meet the requirements of the plans and specifications.

Notify the Engineer of all material sources and before changing any material source or formulation. The Engineer will verify that the specification requirements are met when the Contractor makes a source or formulation change, and may require a new laboratory mixture design, trial batch, or both. The Engineer may sample and test project materials at any time during the project to verify specification compliance in accordance with Item 6, "Control of Materials."

2.1. **Aggregate.** Furnish aggregates from sources that conform to the requirements shown in Table 1 and in accordance with this Section. Aggregate requirements in this Section, including those shown in Table 1, may be modified, or eliminated when shown on the plans. Additional aggregate requirements may be specified when shown on the plans. Provide aggregate stockpiles that meet the definitions in this Section for coarse aggregate, intermediate aggregate, or fine aggregate. Supply aggregates that meet the definitions in [Tex-100-E](#) for crushed gravel or crushed stone. The Engineer will designate the plant or the quarry as the sampling location. Provide samples from materials produced for the project. The Engineer will establish the Surface Aggregate Classification (SAC) and perform Los Angeles Abrasion, Magnesium Sulfate Soundness, and Micro-Deval Abrasion Tests. Perform all other aggregate quality tests shown in Table 1. Document all test results in the mixture design report. The Engineer may perform tests on independent or split samples to verify Contractor test results. Stockpile aggregates for each source and type separately. Determine aggregate gradations for mixture design and production testing based on the washed sieve analysis in accordance with [Tex-200-F](#), Part II.

2.1.1. **Coarse Aggregate.** Coarse aggregate stockpiles must have no more than 20% material passing the No. 8 sieve. Aggregates from sources listed in the Department's *Bituminous Rated Source Quality Catalog* (BRSQC) are preapproved for use. Use only the rated values for hot mix listed in the BRSQC. Rated values for surface treatment (ST) do not apply to coarse aggregate sources used in hot-mix asphalt (HMA).

For sources not listed in the Department's BRSQC:

- build an individual stockpile for each material;
- request that the Department test the stockpile for specification compliance; and
- once approved, do not add material to the stockpile unless otherwise approved.

Provide aggregate from non-listed sources only when tested by the Engineer and approved before use. Allow 30 calendar days for the Engineer to sample, test, and report results for non-listed sources.

Provide coarse aggregate with at least the minimum SAC shown on the plans. SAC requirements only apply to aggregates used on the surface of travel lanes. SAC requirements apply to aggregates used on surfaces other than travel lanes when shown on the plans. The SAC for sources in the Department's *Aggregate Quality Monitoring Program* (AQMP) ([Tex-499-A](#)) is listed in the BRSQC.

2.1.1.1. **Blending Class A and Class B Aggregates.** Class B aggregate meeting all other requirements shown in Table 1 may be blended with a Class A aggregate to meet requirements for Class A materials. Ensure that at least 50% by weight, or volume if required, of the material retained on the No. 4 sieve comes from the Class A aggregate source when blending Class A and Class B aggregates to meet a Class A requirement. Blend by volume if the bulk-specific gravities of the Class A and Class B aggregates differ by more than 0.300.

2.1.2. **Fine Aggregate.** Fine aggregates consist of manufactured sands, screenings, and field sands. Fine aggregate stockpiles must meet the gradation requirements shown in Table 2. Supply fine aggregates that are free of organic impurities. The Engineer may test the fine aggregate in accordance with [Tex-408-A](#) to verify the material is free of organic impurities. No more than 15% of the total aggregate may be field sand or other uncrushed fine aggregate. Use fine aggregate, except field sand, from coarse aggregate sources that meet the requirements shown in Table 1 unless otherwise approved.

Test the stockpile if 10% or more of the stockpile is retained on the No. 4 sieve, and verify that it meets the requirements in Table 1 for crushed face count ([Tex-460-A](#)) and flat and elongated particles ([Tex-280-F](#)).

**Table 1
Aggregate Quality Requirements**

Property	Test Method	Requirement
Coarse Aggregate		
SAC	Tex-499-A (AQMP)	As shown on the plans
Deleterious material, %, Max	Tex-217-F , Part I	1.5
Decantation, %, Max	Tex-217-F , Part II	1.5
Micro-Deval abrasion, %	Tex-461-A	Note 1
Los Angeles abrasion, %, Max	Tex-410-A	40
Magnesium sulfate soundness, 5 cycles, %, Max	Tex-411-A	30 ²
Crushed face count, ³ %, Min	Tex-460-A , Part I	85
Flat and elongated particles @ 5:1, %, Max	Tex-280-F	10
Fine Aggregate		
Linear shrinkage, %, Max	Tex-107-E	3
Combined Aggregates⁴		
Sand equivalent, %, Min	Tex-203-F	45

1. Not used for acceptance purposes. Used by the Engineer as an indicator of the need for further investigation.
2. Unless otherwise shown on the plans.
3. Only applies to crushed gravel.
4. Aggregates, without mineral filler or additives, combined as used in the job-mix formula (JMF).

**Table 2
Gradation Requirements for Fine Aggregate**

Sieve Size	% Passing by Weight or Volume
3/8"	100
#8	70–100
#200	0–15

2.2. **Mineral Filler.** Mineral filler consists of finely divided mineral matter such as agricultural lime, crusher fines, hydrated lime, or fly ash. Mineral filler is allowed unless otherwise shown on the plans. Use no more than 2% hydrated lime or fly ash unless otherwise shown on the plans. The plans may require or disallow specific mineral fillers. Provide mineral filler, when used, that:

is sufficiently dry, free-flowing, and free of clumps and foreign matter as determined by the Engineer;

does not exceed 3% linear shrinkage when tested in accordance with [Tex-107-E](#); and meets the gradation requirements shown in Table 3.

**Table 3
Gradation Requirements for Mineral Filler**

Sieve Size	% Passing by Weight or Volume
#8	100
#200	55-100

- 2.3. **Baghouse Fines.** Fines collected by the baghouse or other dust-collecting equipment may be reintroduced into the mixing drum.
- 2.4. **Binder Material.** Furnish asphalt binder, primer, additives, and water, unless otherwise shown on the plans.
- 2.4.1. **Asphalt Binder.** Provide the asphalt shown on the plans, meeting the requirements of Item 300, "Asphalts, Oils, and Emulsions."
- 2.4.2. **Primer.** Provide an approved asphalt primer consisting of a blend of asphalt cement and hydrocarbon volatiles.
- 2.4.3. **Water.** Provide water that meets the requirements of Item 204, "Sprinkling."
- 2.4.4. **Additives.** Use the type and rate of additive specified when shown on the plans. Additives that facilitate mixing or improve the quality of the mixture may be allowed when approved. Provide the Engineer with documentation, such as the bill of lading, showing the quantity of additives used on the project unless otherwise directed.

When lime or liquid antistripping agents are used, add in accordance with Item 301, "Asphalt Antistripping Agents." Do not add lime directly into the mixing drum of any plant where lime is removed through the exhaust stream unless the plant has a baghouse or dust collection system that reintroduces the lime back into the drum.

- 2.5. **Tack Coat.** Furnish CSS-1H, SS-1H, or a performance-graded (PG) binder with a minimum high-temperature grade of PG 58 for tack coat in accordance with Item 300. Specialized or preferred tack coat materials may be allowed or required when shown on the plans. Do not dilute emulsified asphalts at the terminal, in the field, or at any other location before use. The Department may sample the tack coat to verify specification compliance.

3. EQUIPMENT

Provide required or necessary equipment in accordance with Item 320, "Equipment for Asphalt Concrete Pavement."

4. CONSTRUCTION

Design, produce, store, transport, place, and compact the specified paving mixture in accordance with this Item. Provide the mix design unless otherwise shown on the plans. The Department will perform quality assurance (QA) testing. Provide quality control (QC) testing as needed to meet the requirements of this Item.

- 4.1. **Mixture Design.**
- 4.1.1. **Design Requirements.** Use the typical weight design example in accordance with [Tex-204-F](#), Part I, to design a paving mixture consisting of a uniform mixture of aggregate, asphalt material, primer, additives, and water, if allowed, that meets the requirements shown in Tables 4 and 5, unless otherwise shown on the

plans. Ensure that the mixture leaves the plant in a workable condition. Provide materials that remain workable in a stockpile for at least 6 mo.

Submit a new mixture design at any time during the project. The Engineer must approve all mixture designs before the Contractor can begin production.

4.1.2.

Job-Mix Formula Approval. The job-mix formula (JMF) is the combined aggregate gradation and target asphalt percentage used to establish target values for mixture production. JMF1 is the original laboratory mixture design used to produce the trial batch. The Engineer will verify JMF1 based on plant-produced mixture from the trial batch unless otherwise approved. The Engineer may accept an existing mixture design previously used on a Department project and may waive the trial batch to verify JMF1. Provide the Engineer with split samples of the mixtures and blank samples used to determine the ignition oven correction factors. The Engineer will determine the aggregate and asphalt correction factors from the ignition oven in accordance with [Tex-236-F](#).

**Table 4
Master Gradation Limits (% Passing by Weight or Volume) and VMA Requirements**

Sieve Size	A Coarse Base	B Fine Base	C Coarse Surface	D Fine Surface	F Fine Mixture
2"	100.0 ¹	–	–	–	–
1-1/2"	98.0–100.0	100.0 ¹	–	–	–
1"	78.0–94.0	98.0–100.0	100.0 ¹	–	–
3/4"	64.0–85.0	84.0–98.0	95.0–100.0	100.0 ¹	–
1/2"	50.0–70.0	–	–	98.0–100.0	100.0 ¹
3/8"	–	60.0–80.0	70.0–85.0	85.0–100.0	98.0–100.0
#4	30.0–50.0	40.0–60.0	43.0–63.0	50.0–70.0	70.0–90.0
#8	22.0–36.0	29.0–43.0	32.0–44.0	35.0–46.0	38.0–48.0
#30	8.0–23.0	13.0–28.0	14.0–28.0	15.0–29.0	12.0–27.0
#50	3.0–19.0	6.0–20.0	7.0–21.0	7.0–20.0	6.0–19.0
#200	2.0–7.0	2.0–7.0	2.0–7.0	2.0–7.0	2.0–7.0
Design VMA,² % Minimum					
–	12.0	13.0	14.0	15.0	16.0
Production (Plant-Produced) VMA,² % Minimum					
–	11.5	12.5	13.5	14.5	15.5

1. Defined as maximum sieve size. No tolerance allowed.
2. Voids in mineral aggregates.

**Table 5
Laboratory Mixture Design Properties**

Property	Test Method	Requirement
Target laboratory-molded density, % ¹	Tex-207-F	94.0 ± 1.5
RT _{index} , Min	Tex-XXX-F²	30
No. of gyrations, Max ³	Tex-241-F	450
Cantabro loss, %, Max ⁴	Tex-245-F	15
Hydrocarbon-volatile content, %, Max	Tex-213-F	0.6
Moisture content, %, Max ⁵	Tex-212-F	1.0
Boil test, %, Max ⁶	Tex-530-C	10

1. Unless otherwise shown on the plans.
2. Tex-xxx-F: Ideal Rutting Test (see P2)
3. No. of gyrations with Superpave gyratory compactor (SGC) is used to compact Ideal rutting test specimen to reach 7±0.5% air voids.
4. Cantabro test specimens are compacted using SGC.
5. Unless otherwise approved.
6. Limit may be increased or eliminated when approved.

4.2.

Production Operations. Perform a new trial batch when the plant or plant location is changed. Take corrective action and obtain approval to proceed after any production suspension for noncompliance with the specification.

- 4.2.1. **Stockpiling of Aggregates.** Provide a smooth and well-drained area, cleared of trash, weeds, and grass. Build stockpiles in a manner that will minimize aggregate degradation and segregation. Avoid contamination and mixing of stockpiles. Provide aggregate stockpiles for at least 2 days' production before beginning plant operations. Maintain at least a 2-day aggregate supply throughout the project unless otherwise directed. Stockpile aggregate for each source and type separately. The Engineer may reject stockpiled materials that contact the earth or other objectionable material.
- 4.2.2. **Storage and Heating of Asphalt Materials.** Provide enough asphalt material storage capacity to meet the requirements of the plant. Do not heat the asphalt binder above the temperatures specified in Item 300, or outside the manufacturer's recommended values. Keep all equipment used in the storage and handling of asphalt material clean at all times and operate the equipment in a manner that will prevent contamination by foreign matter.
- 4.2.3. **Storage of the Asphalt Mixture.** Store the asphalt mixture in a surge-storage system or in a stockpile. Provide a smooth and well-drained area, cleared of trash, weeds, and grass, if the asphalt mixture is stored in a stockpile. Build stockpiles in a manner that will minimize aggregate degradation and segregation. Avoid contamination and mixing of stockpiles.
- 4.2.4. **Mixing and Discharge of Materials.** Produce the mixture at a discharge temperature between 145°F and 275°F, as directed. Do not allow the temperature to vary from the selected temperature by more than 25°F. The Department will not pay for or allow placement of any mixture produced above 300°F.
- 4.2.5. **Moisture Content.** Furnish the mixture at a moisture content of no more than 1% by weight when discharged from the mixer, unless otherwise shown on the plans or approved. Cease operations at moisture content above 1% until corrective actions reduce moisture content.
- 4.3. **Hauling Operations.** Clean all truck beds before use to ensure mixture is not contaminated. Use a release agent on the Department's MPL to coat truck beds when a release agent is necessary.
- 4.4. **Placement Operations.** Prepare the surface by removing raised pavement markers and objectionable material, such as moisture, dirt, sand, leaves, and other loose impediments, from the surface before placing mixture. Remove vegetation from pavement edges. Place mixture on the road below 175°F. Place the mixture to produce a smooth, finished surface with a uniform appearance and texture that meet typical section requirements. Offset longitudinal joints of successive courses of mixture by at least 6 in. Place mixture so that longitudinal joints on the surface course coincide with lane lines, or as directed. Ensure that all finished surfaces will drain properly.

When desired, dump the asphalt mixture in a windrow and then place in the finishing machine with windrow pickup equipment unless otherwise shown on the plans. Prevent the windrow pickup equipment from contaminating the mixture.

Defer compaction after placing the paving mixture, as directed, to allow for volatilization. Allow the previous course to dry and cure before placing the next course when placing more than one pavement course. Consider the course cured if the hydrocarbon volatile content of the mixture is 0.4% or less by weight of the mixture when tested in accordance with [Tex-213-F](#), unless otherwise directed.

Use a motor grader to spread the mixture when shown on the plans or approved. Thoroughly aerate the mixture and spread into place using a power motor grader in a uniform layer. Placement in narrow strips or small irregular areas may require hand-spreading.

- 4.4.1. **Weather Conditions.** Place the mixture when the roadway surface temperature is 60°F or higher, unless otherwise approved. Place mixtures only when weather conditions and moisture conditions of the roadway surface are suitable in the opinion of the Engineer unless otherwise shown on the plans.

4.4.2. **Tack Coat.** Clean the surface before placing the tack coat. Apply tack coat uniformly at the approved rate unless otherwise directed. The Engineer will set the rate between 0.04 and 0.10 gal. of residual asphalt per square yard of surface area. Apply a thin, uniform tack coat to all contact surfaces of curbs, structures, and joints. Prevent splattering of the tack coat when placed adjacent to curb, gutter, and structures. Roll the tack coat using a pneumatic tire roller when directed.

4.5. **Compaction.** Furnish the type, size, and number of rollers required for compaction as approved. Furnish at least one medium pneumatic tire roller (minimum 12-ton weight). Use the control strip method in accordance with [Tex-207-F](#), Part IV, to establish rolling patterns that achieve maximum compaction. Follow the selected rolling pattern unless changes that affect compaction occur in the mixture or placement conditions. Establish a new rolling pattern when such changes occur. Compact the pavement to the cross-section of the finished paving mixture as shown on the plans and in accordance with specifications. Operate vibratory rollers in static mode when not compacting, when changing directions, or when the plan depth of the pavement mat is less than 1-1/2 in., unless otherwise directed.

Start by first rolling the joint with the adjacent pavement and then continue by rolling longitudinally at the sides when rolling using three-wheel tandem or vibratory rollers. Proceed toward the center of the pavement, overlapping on successive trips by at least 1 ft., unless otherwise directed. Make alternating trips of the roller slightly different in length. Begin rolling at the low side on superelevated curves, and progress toward the high side unless otherwise directed.

Avoid displacement of the mixture. Correct any displacement that may occur to the satisfaction of the Engineer. Ensure pavement is fully compacted before allowing rollers to stand on the pavement. Use only water or an approved release agent on rollers, tamps, and other compaction equipment unless otherwise directed. Keep diesel, gasoline, oil, grease, and other foreign matter off the mixture.

Use tamps to thoroughly compact the edges of the pavement along curbs, headers, and similar structures, and in locations that will not allow thorough compaction by the rollers. The Engineer may require rolling using a trench roller on widened areas, in trenches, and in other limited areas.

Allow the compacted pavement to cool to 160°F or lower before opening to traffic unless otherwise directed. Sprinkle the finished mat with water or limewater, when directed, to expedite opening the roadway to traffic.

4.6. **Production Testing and Operational Tolerances.** The aggregate gradation and the asphalt binder content of the produced mixture must not vary from the JMF by more than the percentage point tolerances shown in Table 6. The gradation of the produced mixture may fall outside the master grading limits for any of the sieve sizes from 1-1/2 in.–No. 50 if it is within the JMF tolerances. The aggregate gradation of the No. 200 sieve may not exceed the master gradations shown in Table 4. Any sieve size shown in Table 4 with 100% passing requirements will be allowed a 2% tolerance before the material is considered out of specification.

The Engineer may allow alternate methods for determining the asphalt content and aggregate gradation if the aggregate mineralogy is such that [Tex-236-F](#) does not yield reliable results. Provide evidence to the Engineer that results from [Tex-236-F](#) are not reliable before an alternate method will be allowed. Use the applicable test procedure as directed if an alternate test method is allowed.

Cease production if three consecutive tests indicate that the material produced exceeds the tolerances shown in Table 6 for any individual sieve or laboratory-molded density until corrective actions are taken and the results approved. Cease production if two consecutive tests indicate that the asphalt binder content tolerances shown in Table 6 are exceeded until corrective actions are taken and the results approved.

Cease production if the Hveem stability shown in Table 5 is not met for three consecutive tests until corrective actions are taken and the results approved.

**Table 6
Operational Tolerances**

Property	Test Method	Operational Tolerance From JMF
Individual % retained for sieve sizes smaller than 1-1/2" and larger than #8	Tex-200-F	±5.0
Individual % retained for sieve sizes smaller than #8		±3.0
Asphalt binder content, %	Tex-236-F	±0.3
Laboratory-molded density, %	Tex-207-F	±1.0

- 4.7. **Irregularities.** Immediately take corrective action if surface irregularities, including segregation, rutting, raveling, flushing, fat spots, mat slippage, color, texture, roller marks, tears, gouges, streaks, or uncoated aggregate particles, are detected. The Engineer may suspend production or placement operations until the problem is corrected.

Remove and replace any mixture that does not bond to the existing pavement or has other surface irregularities identified above at the expense of the Contractor and to the satisfaction of the Engineer.

- 4.8. **Ride Quality.** Use Surface Test Type A to evaluate ride quality in accordance with Item 585, "Ride Quality for Pavement Surfaces," unless otherwise shown on the plans.

5. MEASUREMENT

This Item will be measured by the ton of composite asphalt concrete mixture of the type used in the completed and accepted work. Measure the weight on scales in accordance with Item 520, "Weighing and Measuring Equipment."

For mixture produced by a weigh batch plant or a modified weigh batch plant, measurement will be determined on the batch scales unless surge storage or stockpiling is used. Keep records of the number of batches, batch design, and the weight of the composite asphalt concrete mixture. The composite asphalt concrete mixture is defined as the asphalt, primer, aggregate, additives, and any residual moisture that are not designated to be deducted. Where surge storage or stockpiling is used, measurement of the material taken from the surge storage bin or stockpile will be taken using truck scales or suspended hopper scales.

6. PAYMENT

The work performed and materials furnished in accordance with this Item and measured as provided under Measurement will be paid for at the unit bid price for "Hot-Mix Cold-Laid Asphalt Concrete Pavement" of the mixture type, SAC, and asphalt binder specified.

This price is full compensation for surface preparation, materials including tack coat, placement, equipment, labor, tools, and incidentals.

Payment adjustment for ride quality, when required, will be determined in accordance with Item 585.

**APPENDIX B. PROPOSED SPECIFICATION FOR IDEAL-RT TEST
PROCEDURE**

Test Procedure for

IDEAL RUTTING TEST



TxDOT Designation: Tex-XXX-F

Effective Date: XXX 2023

1. SCOPE

- 1.1 This test method determines the rutting tolerance index (RT_{Index}) of compacted bituminous mixtures.
 - 1.2 The values given in parentheses (if provided) are not standard and may not be exact mathematical conversions. Use each system of units separately. Combining values from the two systems may result in nonconformance with the standard.
-

2. APPARATUS

- 2.1 *Apparatus used in Tex-241-F.*
- 2.2 *Apparatus used in Tex-207-F.*
- 2.3 *Apparatus used in Tex-227-F.*
- 2.4 *Temperature Chamber or Heating Oven or Water Bath, capable of maintaining $77 \pm 2^\circ\text{F}$ ($25 \pm 1^\circ\text{C}$) and $122 \pm 2^\circ\text{F}$ ($50 \pm 1^\circ\text{C}$).*
- 2.5 *Loading Press, capable of applying a compressive load with a capacity of at least 6,000 lb at a controlled deformation rate of 2 inches per minute.*
- 2.6 *Load Cell, with a resolution of 2 lb and a capacity of at least 6,000 lb.*
- 2.7 *Loading Strip and Supporting Cradle, consisting of 0.75×0.75 inch square steel upper bar and supporting cradle with a concave surface having a radius of curvature equal to the nominal radius of the test specimen. For specimens with a nominal diameter of 5.9 inch (150 mm), as depicted in Figure 1. The length of the loading strips shall exceed the thickness of the specimen by at least 0.2 inch (5 mm). The outer edges of the bottom supporting cradle shall incorporate a fillet (Figure 1) to remove sharp edges.*

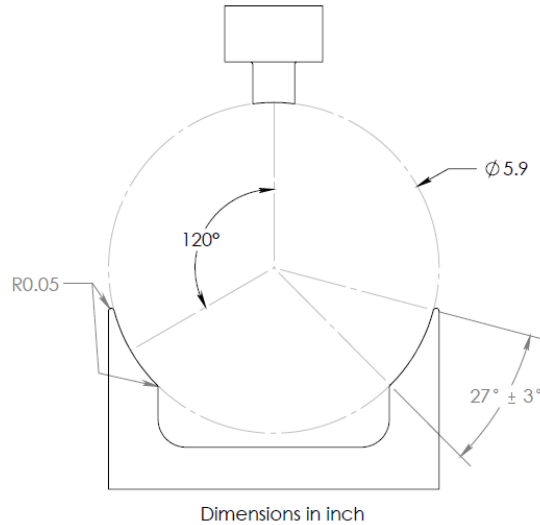

Figure 1. Ideal Rutting Test Fixture

- 2.8 *Displacement Measuring Device*, capable of measuring the displacement with a resolution of ± 0.4 mils (± 0.01 mm). The displacement data measured during the test may need some correction for compensating system compliance.
- 2.9 *Data Acquisition System*, time, load, and displacement data are collected at a minimum of 40 sampling data points per second to obtain a smooth load-displacement curve.

3. SPECIMENS

- 3.1 *Laboratory-Molded Specimens*—Prepare four specimens in accordance with Tex-241-F. Specimen diameter must be 5.9 inches (150 mm) and height must be 2.4 (62 mm) ± 0.1 inch (2 mm).
- 3.1.1 Density of test specimens must be $93 \pm 0.5\%$, except for Permeable Friction Course (PFC) and Crack Attenuating Mix (CAM).
- Note 1**—Mixture weights for laboratory-molded specimens that achieve the density requirement typically vary between 2,400 and 2,600 g.
- 3.1.2 For PFC mixtures, mold test specimens to 50 gyrations (N_{design}).
- 3.1.3 Density of the test specimen must be $95 \pm 0.5\%$ for CAM mixtures.
- 3.2 *Core Specimens*—Specimen diameter must be 6 inches and height must be a minimum of 1.5 inches. There is not a specific density requirement for core specimens.

4. PROCEDURE

- 4.1 *Laboratory-Molded Mixtures:*
- 4.1.1 Mold three specimens in accordance with Section 3.1.

- 4.1.2 Calculate the density of the specimens in accordance with Tex-207-F and Tex-227-F.
- 4.2 *Roadway Cores:*
- 4.2.1 Obtain roadway cores meeting the requirements of Section 3.2.
- 4.2.2 Trim the bottom or top of the core only when necessary to remove any foreign matter and to provide a level and smooth surface for testing.
- 4.3 Record the density, height, and diameter of each molded specimen or roadway core.
- 4.4 *Condition specimens*
- 4.4.1 For Hot-Mixed Cold-Laid mixtures, place the specimens or cores in the temperature chamber or oven long enough to ensure a consistent temperature of $77 \pm 2^\circ\text{F}$ ($25 \pm 1^\circ\text{C}$) throughout the specimen before testing.
Note 2—For room temperature specimens, 1.5 hr. conditioning in a temperature chamber of 77°F or a minimum of 30 min. conditioning in a water bath of 77°F is required.
- 4.4.2 For all other mixtures, place the specimens or cores in the temperature chamber or oven long enough to ensure a consistent temperature of $122 \pm 2^\circ\text{F}$ ($50 \pm 1^\circ\text{C}$) throughout the specimen before testing. Do not leave the specimens or cores in the temperature chamber or oven for more than 24 hr.
Note 3—For room temperature specimens, 3 hr. conditioning in a temperature chamber of 122°F or a minimum of 45 min. conditioning in a water bath of 122°F is required.
- 4.5 Calibrate the loading press to use a deformation rate of 2 inches per minute.
- 4.6 Carefully place one specimen on the lower supporting cradle with uniform contact and ensure the specimen is centered.
- 4.7 Slowly lower top loading strip into light and uniform contact with the specimen.
- 4.8 Apply the load at a controlled deformation rate of 2 inches per minute. The test may be terminated 5 sec. after the peak load. During the testing, record the time, load, and displacement at a minimum sampling rate: 40 data points per second.
Note 4—Testing a specimen must be completed in 3 min. or less after removal from the environmental chamber to maintain a uniform specimen temperature.
- 4.9 Repeat Sections 4.6–4.9 for each specimen.

5. CALCULATIONS

- 5.1 Calculate the shear strength of asphalt mixture from the measured maximum load:

$$\tau_f = 0.356 \times \frac{P_{max}}{t \times w} \quad (1)$$

where:

τ_f = Shear strength, psi
 P_{max} = Measured maximum load, lb
 t = Specimen thickness, inch
 w = Specimen thickness, inch

5.2 Calculate the rutting tolerance index (RT_{Index}) from the shear strength:

$$RT_{Index} = 0.4575 \times \frac{\tau_f}{1 \text{ psi}} \quad (2)$$

where:

RT_{Index} = Rutting tolerance index

τ_f = Shear strength from Eq 1, psi

Note 4—1 psi is a unit cancelation factor and 0.4575 is a scale factor.

6. REPORT

6.1 Report the following for each specimen:

- Density,
- Thickness,
- Diameter,
- Rutting tolerance index, and
- Shear strength.

6.2 Report the average rutting tolerance index and the average shear strength of the tested specimens or cores to the nearest whole number.

REFERENCES

- AASHTO. (2022). Standard method of test for determining the asphalt binder content of hot mix asphalt (HMA) by the ignition method.
- Anderson, D. A., Thomas Jr, H. R., Siddiqui, Z., & Krivohlavek, D. D. (1988). More effective cold, wet-weather patching materials for asphalt pavements (No. FHWA-RD-88-001). United States. Federal Highway Administration.
- Arambula-Mercado, E., Caro, S., Torres, C. A. R., Karki, P., Sanchez-Silva, M., & Park, E. S. (2019). Evaluation of FC-5 with PG 76-22 HP to Reduce Raveling.
- ASTM D8360-22, 2022, Standard Test Method for Determination of Rutting Tolerance Index of Asphalt Mixture Using the Ideal Rutting Test, ASTM International, West Conshohocken, PA, 2022, DOI: 10.1520/D8360-22, www.astm.org
- Button, J. W., Chowdhury, A., & Bhasin, A. (2006). Transitioning from Texas gyratory compactor to Superpave gyratory compactor. *Transportation research record*, 1970(1), 106-115.
- Chatterjee, S., White, R. P., Smit, A., Prozzi, J., & Prozzi, J. A. (2006). Development of mix design and testing procedures for cold patching mixtures (No. FHWA/TX-05/0-4872-1).
- Cominsky, R. J., Huber, G. A., Kennedy, T. W., & Anderson, M. (1994). The superpave mix design manual for new construction and overlays (No. SHRP-A-407). Washington, DC, USA: Strategic Highway Research Program.
- Dongré, R., Morari, E., & Pyle, R. A. (2013). Development of a simple test to determine workability and field compaction temperatures of asphalt concrete.
- Estakhri, C. K., Button, J. W., & Jimenez, L. M. (1999b). Guidelines for improving the performance of TxDOT item 334, hot-mix, cold-laid asphalt concrete paving mixtures (No. FHWA/TX-99/1717-S). Texas Transportation Institute.
- Estakhri, C. K., Jimenez, L. M., & Button, J. W. (1999a). Evaluation of Texas DOT item 334, hot-mix, cold-laid asphalt concrete paving mixtures. Texas Transportation Institute, Texas A&M University System.
- Estakhri, C., Kassem, E., Arambula, E., & Scullion, T. (2015). Improving DMS 9210 requirements for limestone rock asphalt-final report (No. FHWA/TX-15/0-6686-2). Texas A&M Transportation Institute.
- Item 334 Hot-Mix Cold-Laid Asphalt Concrete Pavement. (2014). Retrieved July 27, 2023, from <https://ftp.dot.state.tx.us/pub/txdot-info/cmd/cserve/specs/2014/standard/s334.pdf>
- Kandhal, P. S., & Mellott, D. B. (1981). Rational approach to design of bituminous stockpile patching mixtures. *Transportation Research Record*, (821).

Oregon Department of Transportation. (2016). Standard Guidelines for Product Review for Asphalt Cold Patch, High Performance.

Roberts, F. L., Kandhal, P. S., Brown, E. R., Lee, D. Y., & Kennedy, T. W. (1996). Hot Mix Asphalt Materials, Mixture Design, and Construction NAPA Education Foundation. Lanham, Maryland.

SP334-003, Special Provision to Item 334 Hot-Mix Cold-Laid Asphalt Concrete Pavement. (2021). Retrieved July 27, 2023, from <https://ftp.dot.state.tx.us/pub/txdot-info/cmd/cserve/specs/2014/prov/sp334003.pdf>

Standard Specifications for Construction and Maintenance of Highways, Streets, and Bridges. (2014). Retrieved July 27, 2023, from <https://ftp.dot.state.tx.us/pub/txdot-info/cmd/cserve/specs/2014/standard/specbook-2014.pdf>

Tex-200-F, Sieve Analysis of Fine and Coarse Aggregates. (2004). Retrieved July 27, 2023, from https://ftp.dot.state.tx.us/pub/txdot-info/cst/TMS/200-F_series/archives/200-1104.pdf

Tex-204-F, Design of Bituminous Mixtures. (2004). Retrieved July 27, 2023, from https://ftp.dot.state.tx.us/pub/txdot-info/cst/TMS/200-F_series/archives/204-1204.pdf

Tex-207-F, Test Procedure for Determining Density of Compacted Bituminous Mixtures. (2007). Retrieved July 27, 2023, from https://ftp.dot.state.tx.us/pub/txdot-info/cst/TMS/200-F_series/archives/207-0907.pdf

Tex-208-F, Test for Stabilometer Value of Bituminous Mixtures. (1999). Retrieved July 27, 2023, from https://ftp.dot.state.tx.us/pub/txdot-info/cst/TMS/200-F_series/archives/208-0899.pdf

Tex-212-F, Determining Moisture Content of Bituminous Mixtures. (2004). Retrieved July 27, 2023, from https://ftp.dot.state.tx.us/pub/txdot-info/cst/TMS/200-F_series/archives/212-1104.pdf

Tex-213-F, Determining Hydrocarbon-Volatile Content of Bituminous Mixtures. (1999). Retrieved July 27, 2023, from https://ftp.dot.state.tx.us/pub/txdot-info/cst/TMS/200-F_series/archives/213-0899.pdf

Tex-236-F, Determining Asphalt Content from Asphalt Paving Mixtures by the Ignition Method. (2011). Retrieved July 27, 2023, from https://ftp.dot.state.tx.us/pub/txdot-info/cst/TMS/200-F_series/archives/236-1011.pdf

Tex-242-F, Hamburg Wheel-tracking Test. (2004). Retrieved July 27, 2023, from https://ftp.dot.state.tx.us/pub/txdot-info/cst/TMS/200-F_series/archives/242-1104.pdf

Tex-245-F, Test Procedure for CANTABRO LOSS. (2019). Retrieved July 27, 2023, from https://ftp.dot.state.tx.us/pub/txdot-info/cst/TMS/200-F_series/archives/245-0719.pdf

Tex-248-F, Test Procedure for OVERLAY TEST. (2019). Retrieved July 27, 2023, from https://ftp.dot.state.tx.us/pub/txdot-info/cst/TMS/200-F_series/archives/248-0719.pdf

Tex-250-F, Test Procedure for IDEAL CRACKING TEST. (2019). Retrieved July 27, 2023, from https://ftp.dot.state.tx.us/pub/txdot-info/cst/TMS/200-F_series/archives/250-0619.pdf

Tex-530-C, Test Procedure for Effect of Water on Bituminous Paving Mixtures. (1999). Retrieved July 27, 2023, from https://ftp.dot.state.tx.us/pub/txdot-info/cst/TMS/500-C_series/archives/530-0899.pdf

Zhou, F., Crockford, B., Zhang, J., Hu, S., Epps, J., & Sun, L. (2019). Development and validation of an ideal shear rutting test for asphalt mix design and QC/QA. *Journal of the Association of Asphalt Paving Technologists*, 88, 719–750.

Zhou, F., Im, S., Sun, L., & Scullion, T. (2017). Development of an IDEAL cracking test for asphalt mix design and QC/QA. *Road Materials and Pavement Design*, 18(sup4), 405–427.