

A UNIQUE VENUE  
IN THE CITY OF NEW ORLEANS



AVENUE  
GALLERY

840 ST. CHARLES AVENUE | NEW ORLEANS | 70130

The Times-Picayune  
THE NEW ORLEANS ADVOCATE



A  
*unique venue*  
IN THE CITY  
OF NEW ORLEANS

The Avenue Gallery is located in the heart of the Central Business District, less than 1 mile from the French Quarter and walking distance to many art galleries, museums, and great local hot spots.

The Avenue Gallery is ideal for your corporate meeting, community gathering, Fundraising Gala, or Social event. The multiple locations throughout the building provide flexibility to cater to your specific needs.



FULL SIZE  
COMMERCIAL  
CATERING KITCHEN

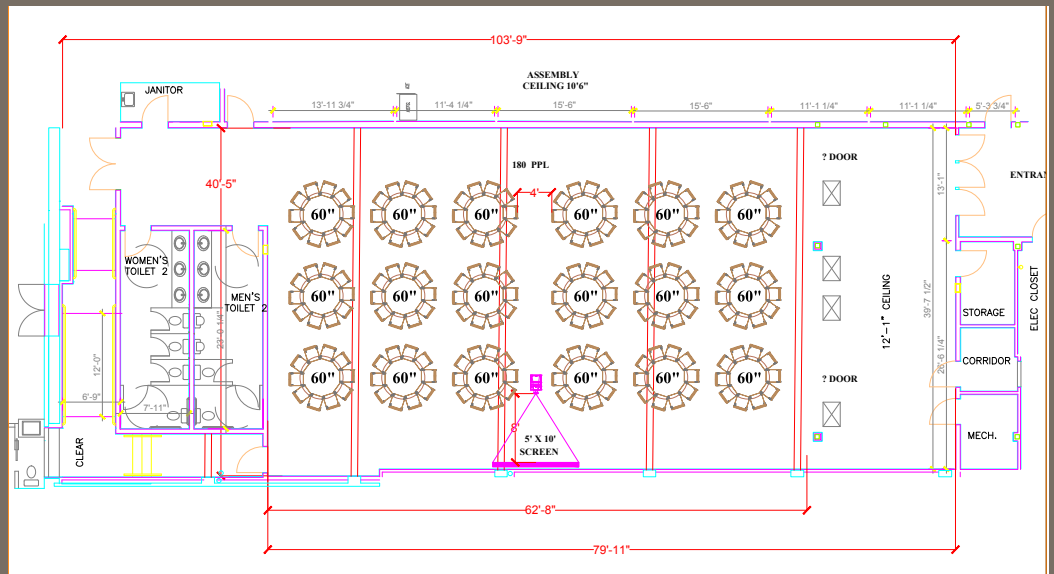

PARKING LOT THAT  
CAN BE TENTED FOR A  
LARGE SCALE EVENT

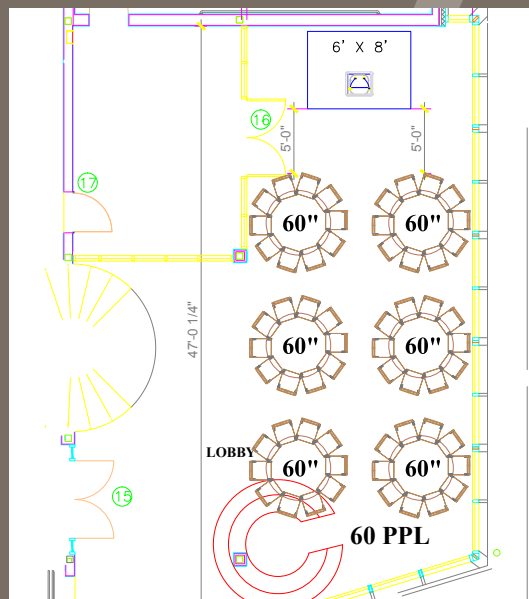
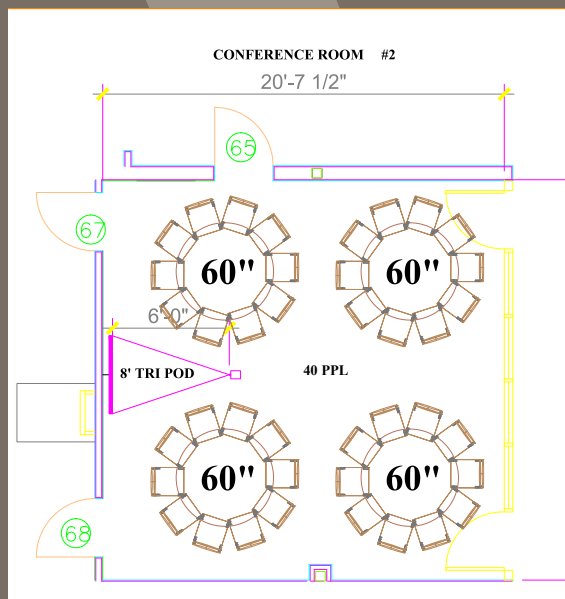
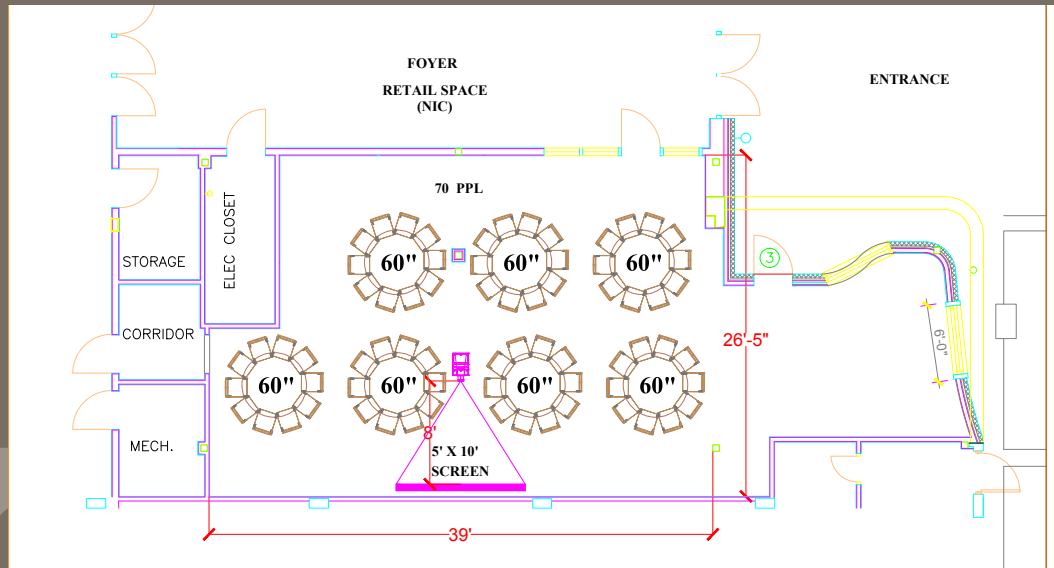

2ND FLOOR  
ACCESS VIA  
STAIRS OR  
ELEVATOR



The first floor offers one large, 2,500?? square foot space that can be configured easily for a seated event or reception.

The second floor is 5,000 ?? square feet that can be customized for a reception as well as a large, private, balcony that overlooks St. Charles Avenue with a fantastic view of the New Orleans cityscape.



The reception space offers a birds eye view into The New Orleans Advocate's working newsroom. This space is ideal for your smaller get together.

Your guests may enter the second floor from the custom built spiral staircase.







## Frequently Asked Questions

### What does The Avenue Gallery provide with facility rentals?

**Facility rentals** include the space(s) rented, security and an on-site attendant (JC). All beverage service, catering, furniture rental, A/V, and any other services are contracted through third-party vendors.

**All third-party vendors** must be approved by The Avenue Gallery.

The **on-site attendant** acts only as an intermediary between The Avenue Gallery, client and third-party vendors for the interests of The Avenue Gallery, and does not serve as an event planner for the client.

The Avenue Gallery does own a number of **chairs** and **tables** available for a rental fee.

### Can I bring in my own caterer?

The Avenue Gallery allows clients to bring in **outside caterers** at no additional charge. All caterers must be licensed and insured, approved by The Avenue Gallery, and available for an on-site meeting with the marketing coordinator no less than **30 days prior to the date of the event**.

### Does Avenue Gallery provide parking?

Depending on the time and size of the event and for a fee, parking could be made available.

**Adjacent parking lots** are not owned by The Avenue Gallery. Parking Arrangements can be made with Premium Parking via [premiumparking.com](http://premiumparking.com).

**FLOOR 1 |**

***Main Assembly Hall***

(CITY PARK HALL INCLUDED):

FULLY SEATED: **150-175**

RECEPTION: **400**

**\$5,000**

**FLOOR 2 |**

***Reception Area & Terrace:***

FULLY SEATED INSIDE: **80-100**

RECEPTION: **150-200**

**\$5,000**

**OTHER AMENITIES:**

CATERING KITCHEN, WIFI, FLAT PANEL TV'S

**AVENUE**  
**GALLERY**

For more information and a  
tour, contact Emily Ward at  
(225) 388-0244 or  
[eward@theadvocate.com](mailto:eward@theadvocate.com)