

TYPICAL NOTES FOR 3/32" PLANS

1. INTERIOR DWELLING UNIT DIMENSIONS OR INTERIOR PUBLIC SPACE DIMENSIONS: SEE 1/4" FLOOR PLANS.
2. DOOR SYMBOLS: SEE 1/4" FLOOR PLANS
3. INTERIOR FINISHED: SEE 1/4" FLOOR PLANS.
4. EXTERIOR DIMENSIONS: INDICATED TO MAIN GRID LINES; TO CENTER LINE OF WINDOWS OR DOOR OPENINGS; AND TO FACE OF MASONRY, CONCRETE OR STUD WALLS AT EXTERIOR WALLS (AS APPLICABLE).
5. INTERIOR DIMENSIONS: APPLIES ONLY TO FACE OF STUD WALLS FACING CORRIDORS; TO CENTER LINE OF CORRIDORS; TO MAIN GRID LINES; AND TO CENTER LINE OF DWELLING UNIT SEPARATION WALLS.



1923 VERMONT AVE NW, 2ND FLR
WASHINGTON, DC 20001
t. 301.588.4800
www.tortigallas.com

TideLock

PROJECT LOCATION
1033, 1055, & 1111 N FAIRFAX ST
ALEXANDRIA, VA 22314

OWNER / DEVELOPER
TIDELock PROPERTY OWNER LLC

STRUCTURAL ENGINEER
SK&A | STRUCTURAL ENGINEERS
301.881.1441

MEP ENGINEER
SUMMIT ENGINEERS, INC
703.533.5593

CIVIL ENGINEER
WALTER L. PHILLIPS
703.532.6163

LANDSCAPE ARCHITECT
MAHAN RYKIEL ASSOCIATES
410.235.6001

SUSTAINABILITY CONSULTANT
GREENSHAPE LLC
202.544.1400

Key Plan

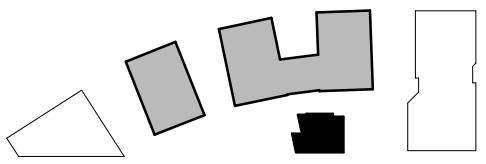

Issue

NO.	DATE
1 SCHEMATIC DESIGN	01/06/2021
2 DESIGN CRITERIA	06/07/2021
3 CD UPDATE SET	10/29/2021
4 PERMIT SET	04/08/2022

Revisions

NO.	DATE
-----	------

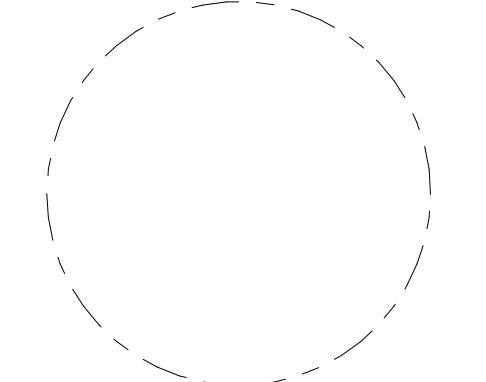

Retail Building- 1st, 2nd, Deck, Roof

PRINCIPAL IN CHARGE
DA

PROJECT ARCHITECT
JS

DRAWN
SI, VS, RG

DATE
07/11/2022

SCALE:
As indicated

APPROVED
XY

JOB NO.
18403.38A

DRAWING NO.
A241

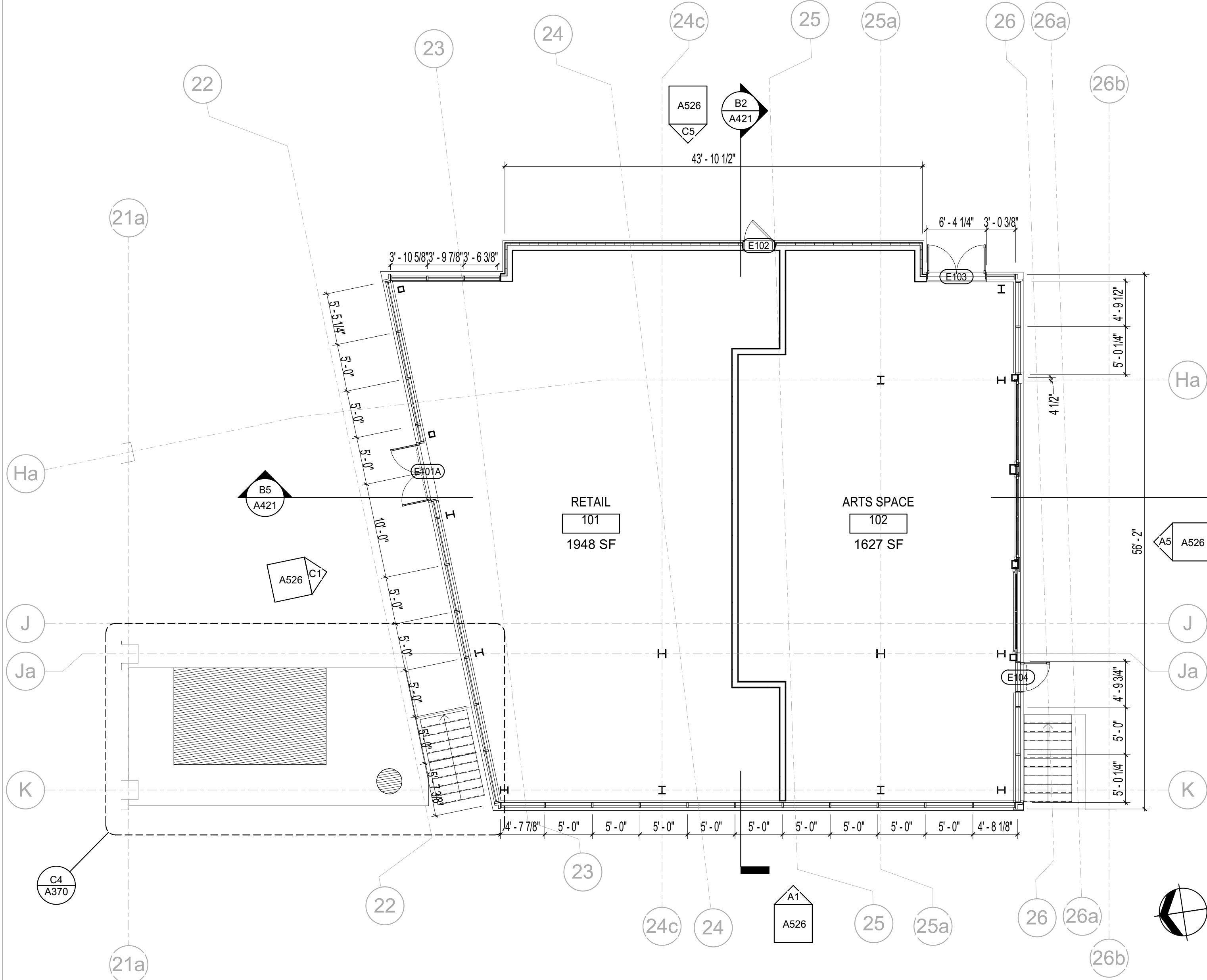

B1 1st Floor -Retail
1/8" = 1'-0"

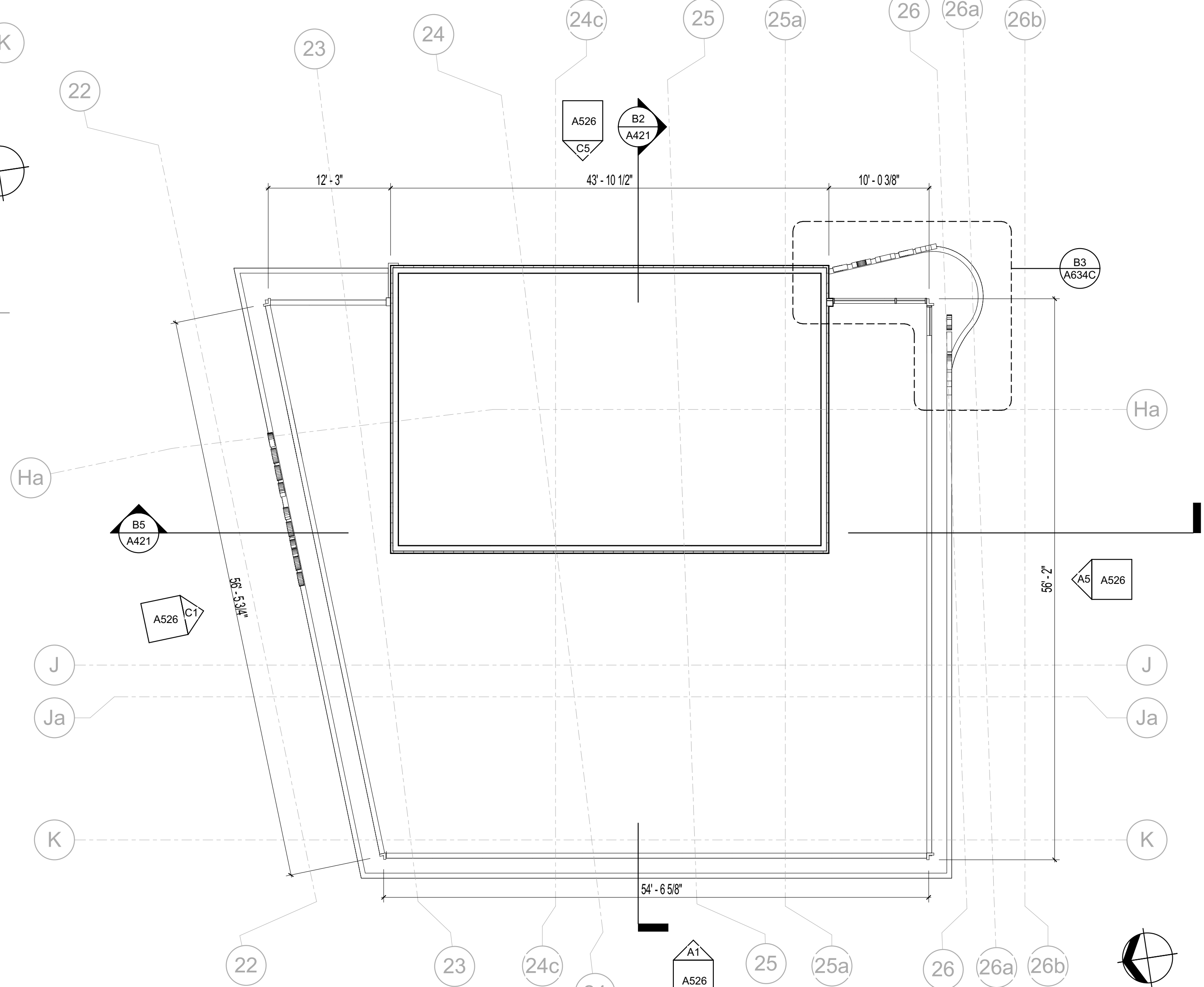

B5 Retail Roof
1/8" = 1'-0"

PERMIT SET

Exterior Materials Keynote Legend	
Key Value	Keynote Text
3.1	CAST STONE COLUMN COVER
4.1	BRICK #1 ACME BRICK STEELE GREY
4.2	BRICK #2 PALMETTO MEDIUM RED SMOOTH
4.3	BRICK #3 ENDICOTT RAVENSWOOD IRONSPOT VELOUR
4.4	ROCKCAST VENEER - COLOR SHADOW
5.1	GLASS RAILING SYSTEM
5.2	PREFINISHED METAL COPING
5.3	METAL MECH SCREEN
5.6	METAL PANEL CANOPY
7.1	METAL PANEL COLOR #1
7.2	METAL PANEL COLOR #2
7.3	METAL PANEL COLOR #3
7.4	METAL PANEL COLOR #4
7.5	METAL PANEL COLOR #5
7.6	CUSTOM ALUMINUM TRIM
8.1	ALUMINUM WINDOW SYSTEM
8.4	STOREFRONT SYSTEM
8.7	BIFOLD DOOR
8.9	MECHANICAL EXHAUST GRILLE
8.10	DRYER EXHAUST

TORTI GALLAS + PARTNERS
 1923 VERMONT AVE NW, 2ND FLR
 WASHINGTON, DC 20001
 t. 301.588.4800
 www.tortigallas.com

TideLock

PROJECT LOCATION
 1033, 1055, & 1111 N FAIRFAX ST
 ALEXANDRIA, VA 22314

OWNER / DEVELOPER
 TIDELOCK PROPERTY OWNER LLC

STRUCTURAL ENGINEER
 SK&A | STRUCTURAL ENGINEERS
 301.881.1441

MEP ENGINEER
 SUMMIT ENGINEERS, INC
 703.533.5593

CIVIL ENGINEER
 WALTER L. PHILLIPS
 703.532.6163

LANDSCAPE ARCHITECT
 MAHAM RYKIEL ASSOCIATES
 410.235.6001

SUSTAINABILITY CONSULTANT
 GREENSHAPE LLC
 202.544.1400

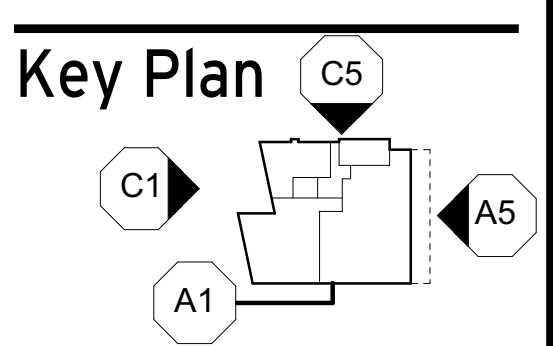

Issue	
NO.	DATE
1	01/06/2021
2	06/07/2021
3	10/29/2021
4	04/08/2022

Revisions	
NO.	DATE

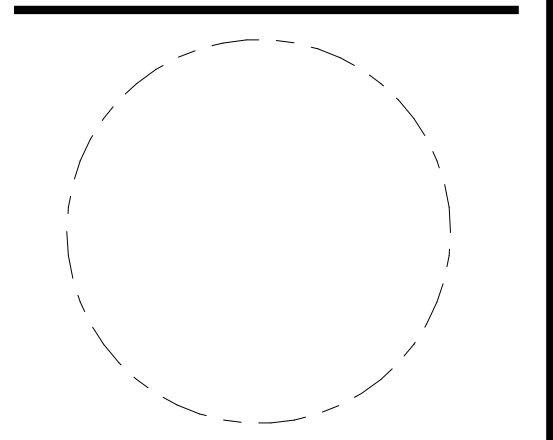

Retail

PRINCIPAL IN CHARGE
 DA

PROJECT ARCHITECT
 JS

DRAWN
 SI, VS, RG

DATE 07/11/2022	APPROVED XY
SCALE: As indicated	JOB NO. 18403.38A

DRAWING NO.
A526

PERMIT SET

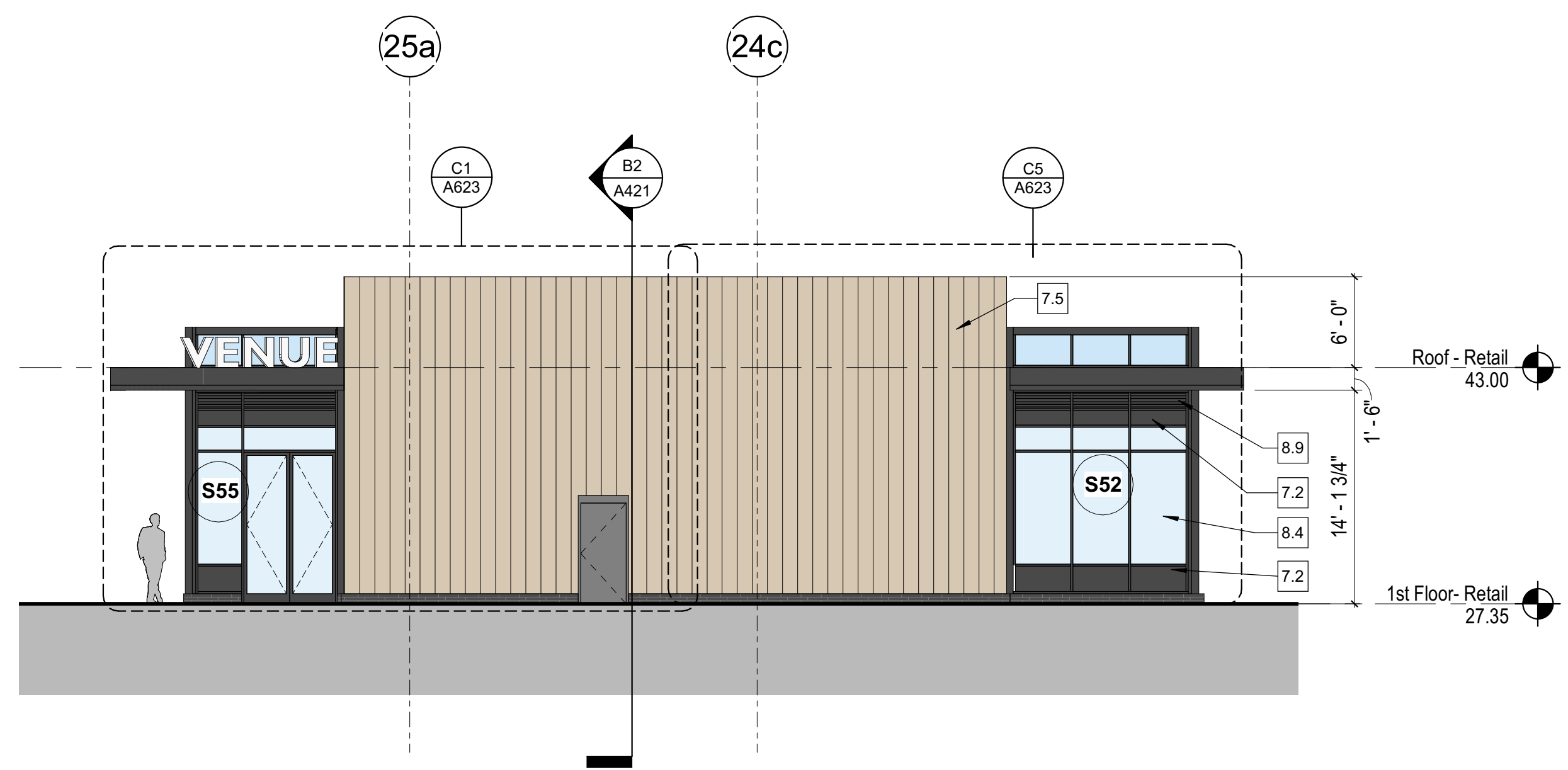
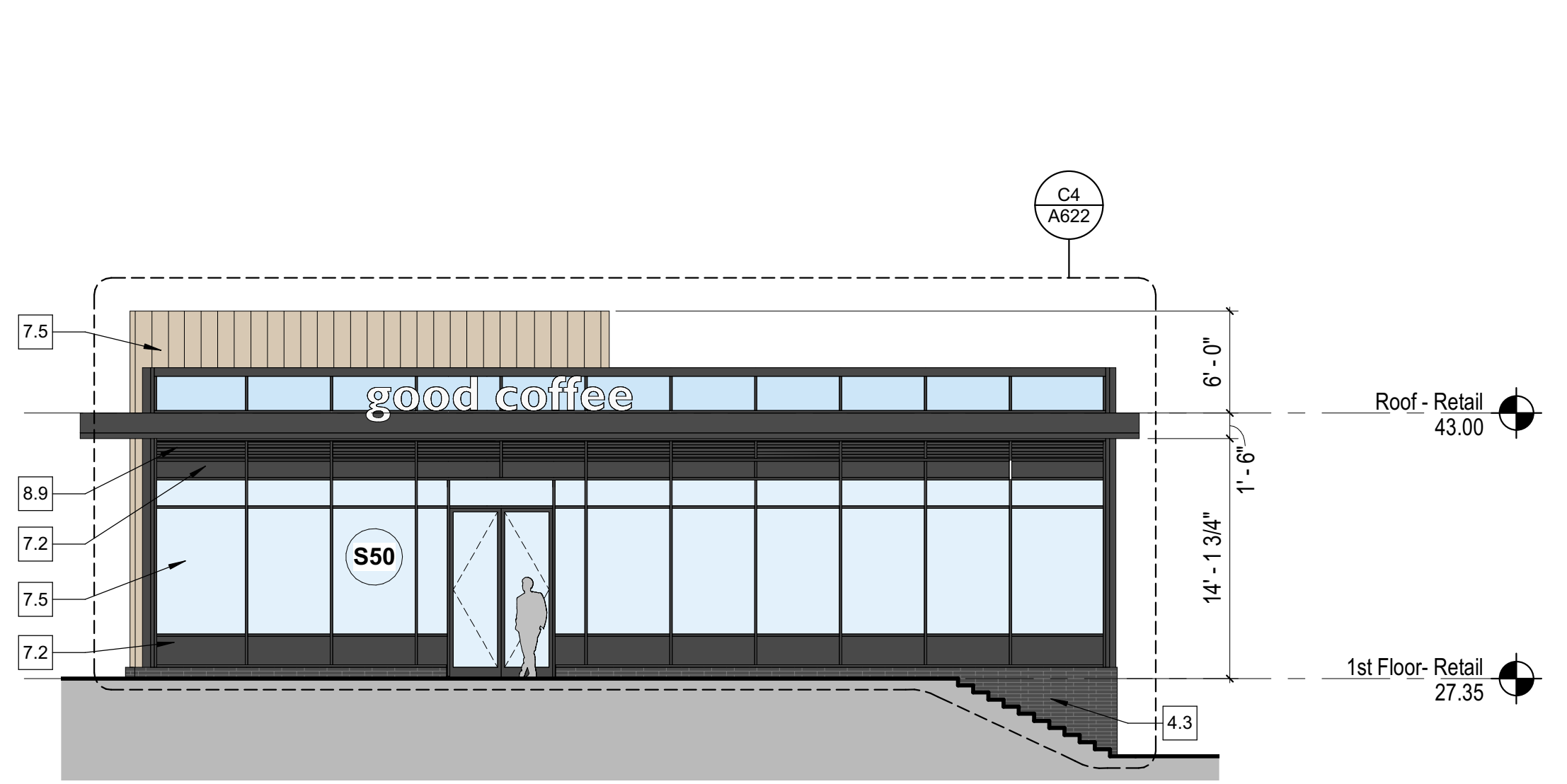

C1 Retail - North
 1/8" = 1'-0"

C5 Retail - East
 1/8" = 1'-0"

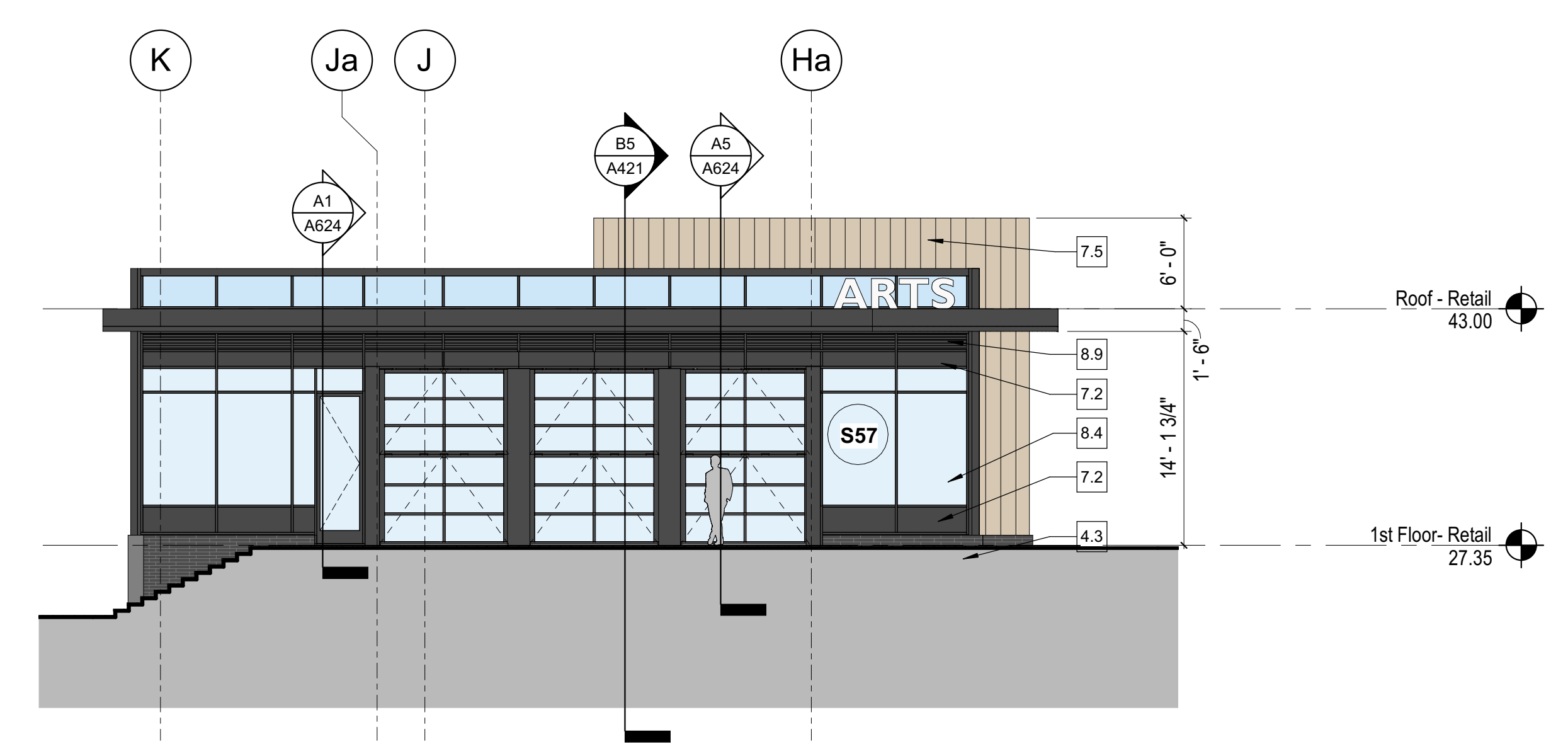
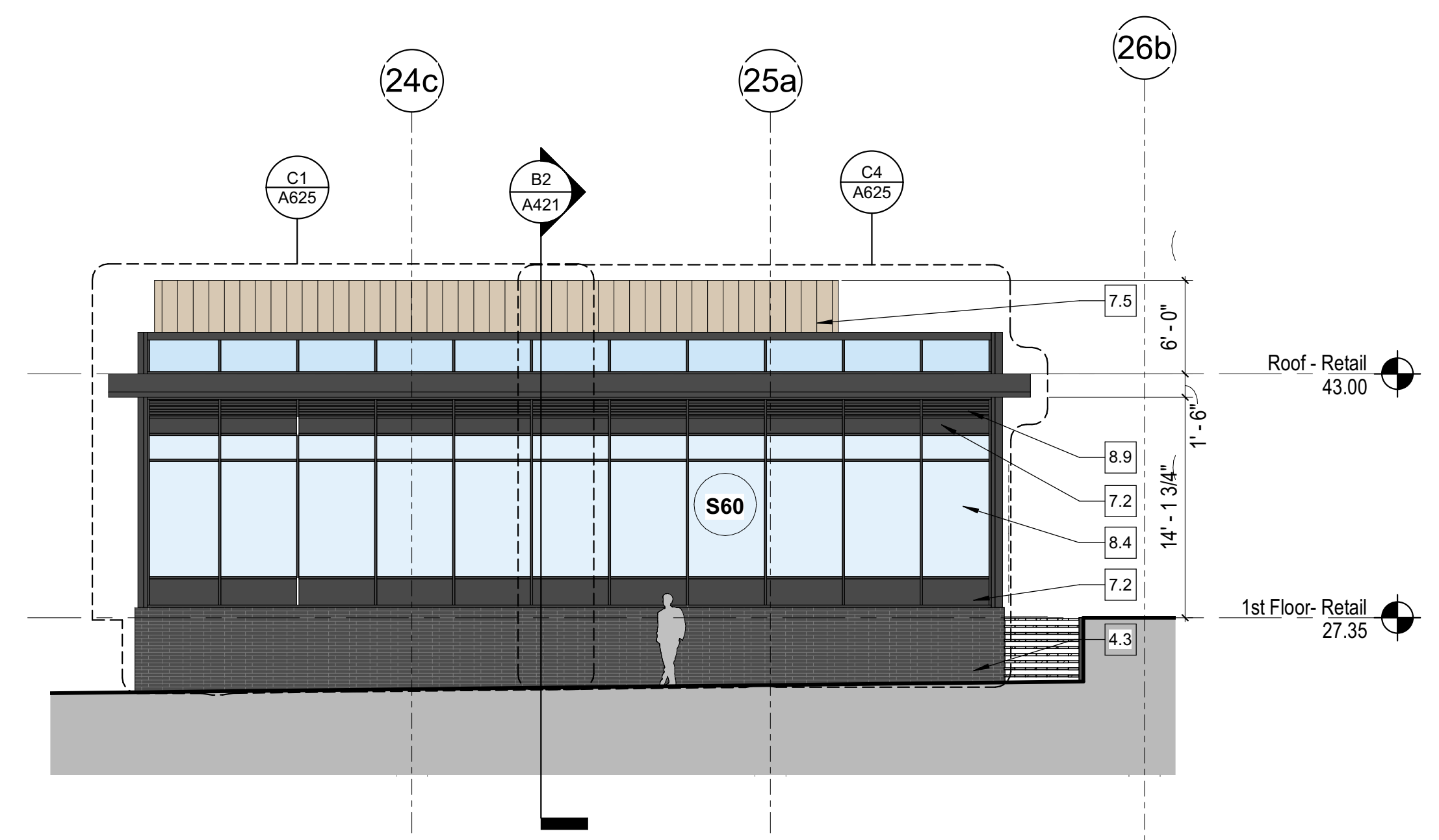

A1 Retail - West
 1/8" = 1'-0"

A5 Retail - South
 1/8" = 1'-0"

TideLock

PROJECT LOCATION
1033, 1055, & 1111 N FAIRFAX ST
ALEXANDRIA, VA 22314

OWNER / DEVELOPER
TIDELock PROPERTY OWNER LLC

STRUCTURAL ENGINEER
SK&A | STRUCTURAL ENGINEERS
301.881.1441

MEP ENGINEER
SUMMIT ENGINEERS, INC
703.533.5593

CIVIL ENGINEER
WALTER L. PHILLIPS
703.532.6163

LANDSCAPE ARCHITECT
MAHAN RYKIEL ASSOCIATES
410.235.6001

Key Plan

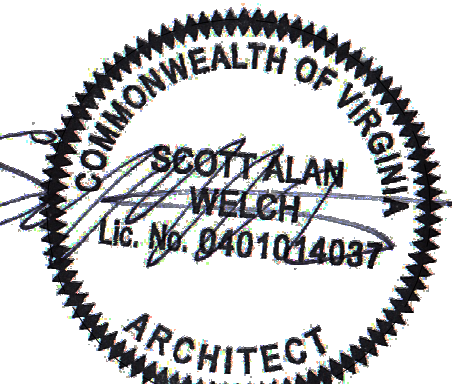

Condo Mockup Panel

PRINCIPAL IN CHARGE
D.A.

PROJECT ARCHITECT
J.S.

DRAWN
S.I., V.S., C.R., R.G., P.B.

DATE 07/11/2022 **APPROVED** X.Y.

SCALE: 3/8" = 1'-0" **JOB NO.** 18403.38A

DRAWING NO.
A0038

Exterior Materials Keynote Legend	
Key Value	Keynote Text
3.1	CAST STONE COLUMN COVER
4.1	BRICK #1 ACME BRICK STEELE GREY
4.2	BRICK #2 PALMETTO MEDIUM RED SMOOTH
4.3	BRICK #3 ENDICOTT RAVENSWOOD IRONSPOT VELOUR
4.4	ROCKCAST VENEER - COLOR SHADOW
5.1	GLASS RAILING SYSTEM
5.2	PREFINISHED METAL COPING
5.3	METAL MECH SCREEN
5.6	METAL PANEL CANOPY
7.1	METAL PANEL COLOR #1
7.2	METAL PANEL COLOR #2
7.3	METAL PANEL COLOR #3
7.4	METAL PANEL COLOR #4
7.5	METAL PANEL COLOR #5
7.6	CUSTOM ALUMINUM TRIM
8.1	ALUMINUM WINDOW SYSTEM
8.4	STOREFRONT SYSTEM
8.7	BIFOLD DOOR
8.9	MECHANICAL EXHAUST GRILLE
8.10	DRYER EXHAUST

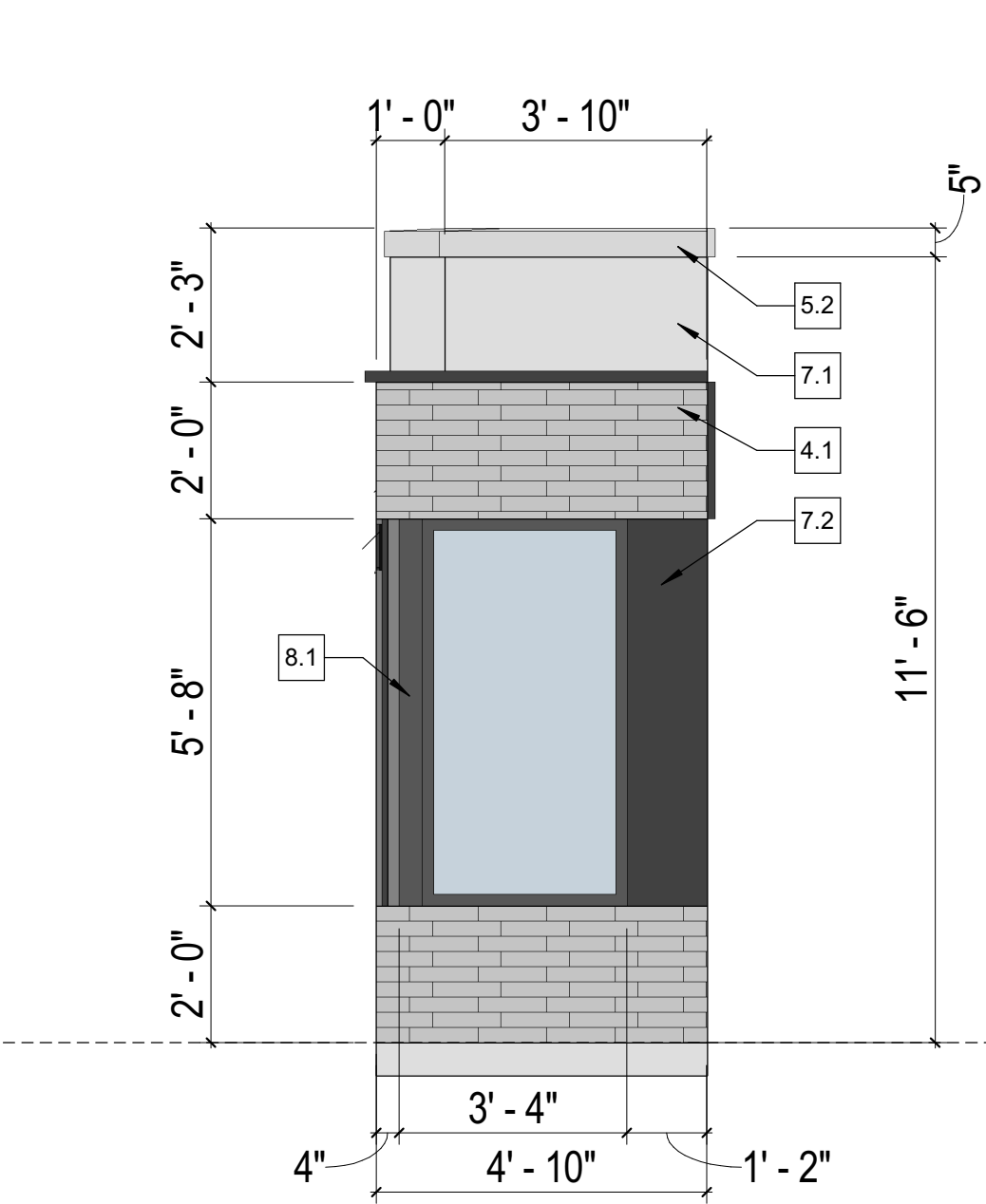

2 Condo Mockup Elevation East
3/8" = 1'-0"

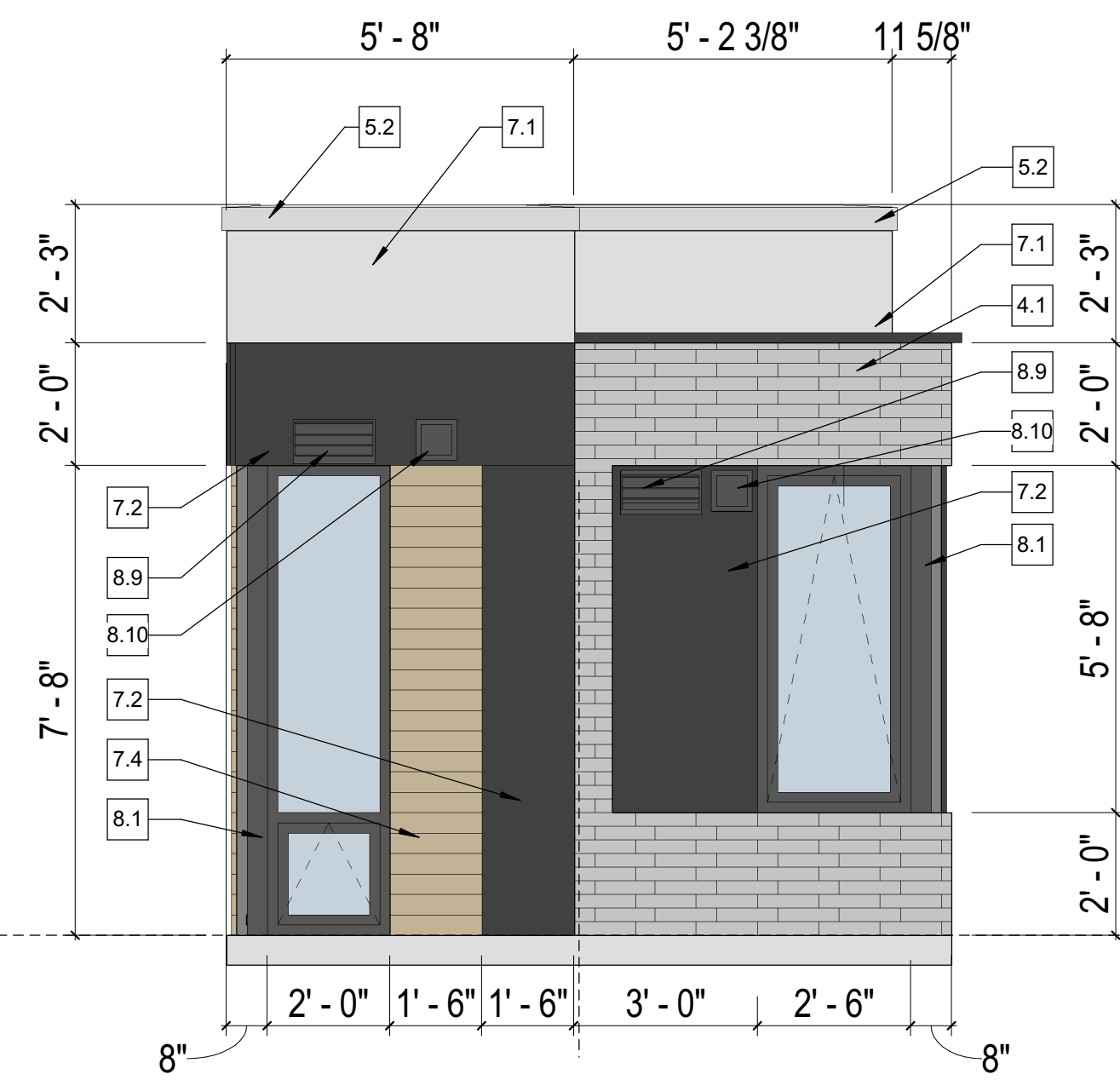

3 Condo Mockup Elevation South
3/8" = 1'-0"

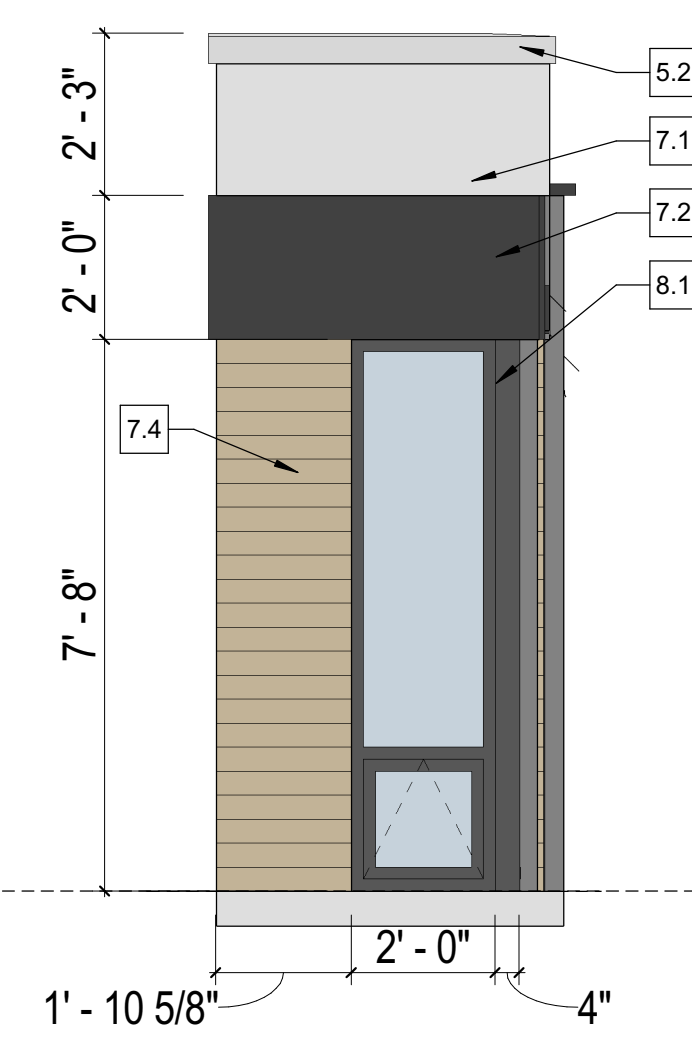

4 Condo Mockup Elevation West
3/8" = 1'-0"

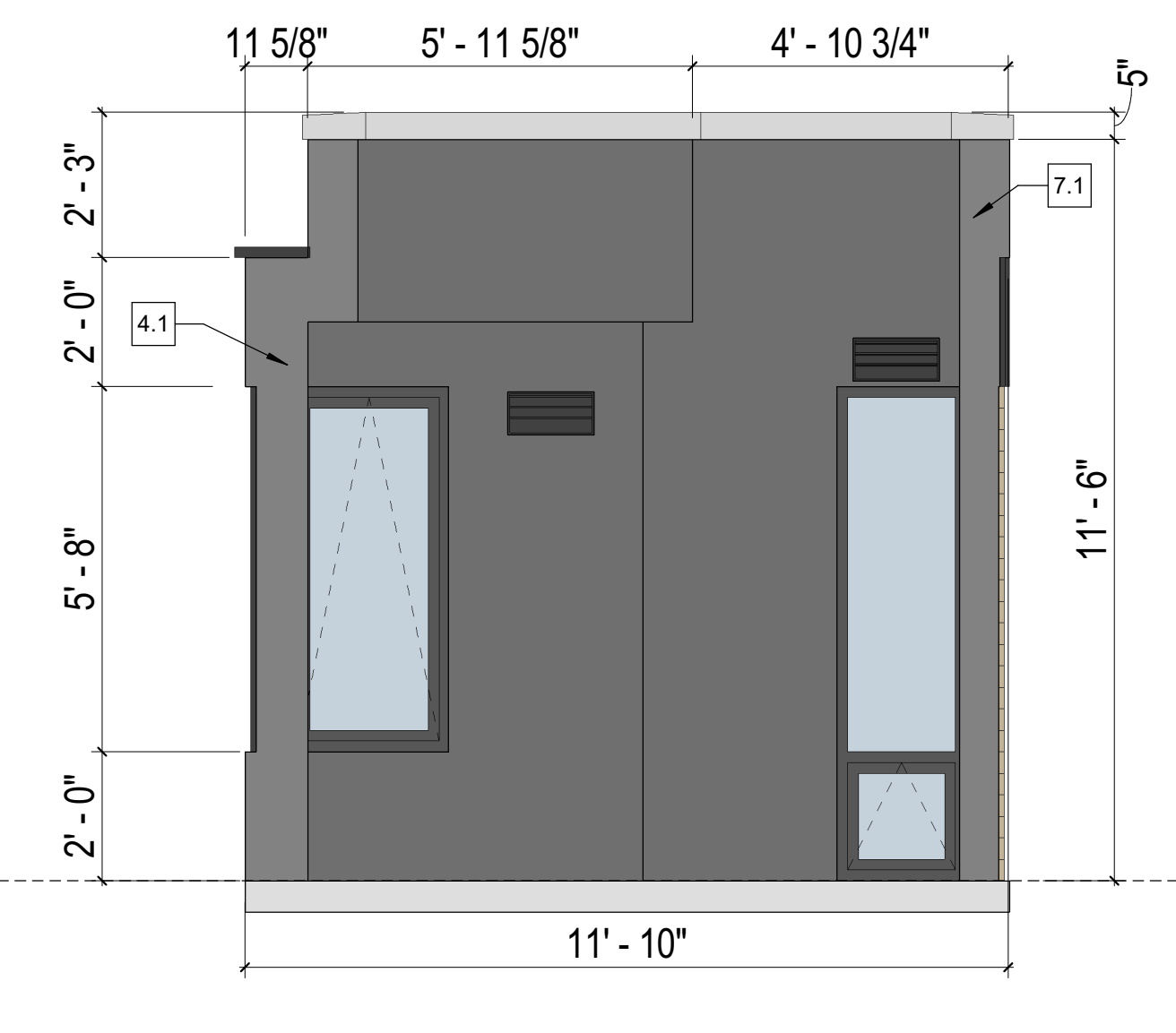

5 Condo Mockup Elevation North
3/8" = 1'-0"

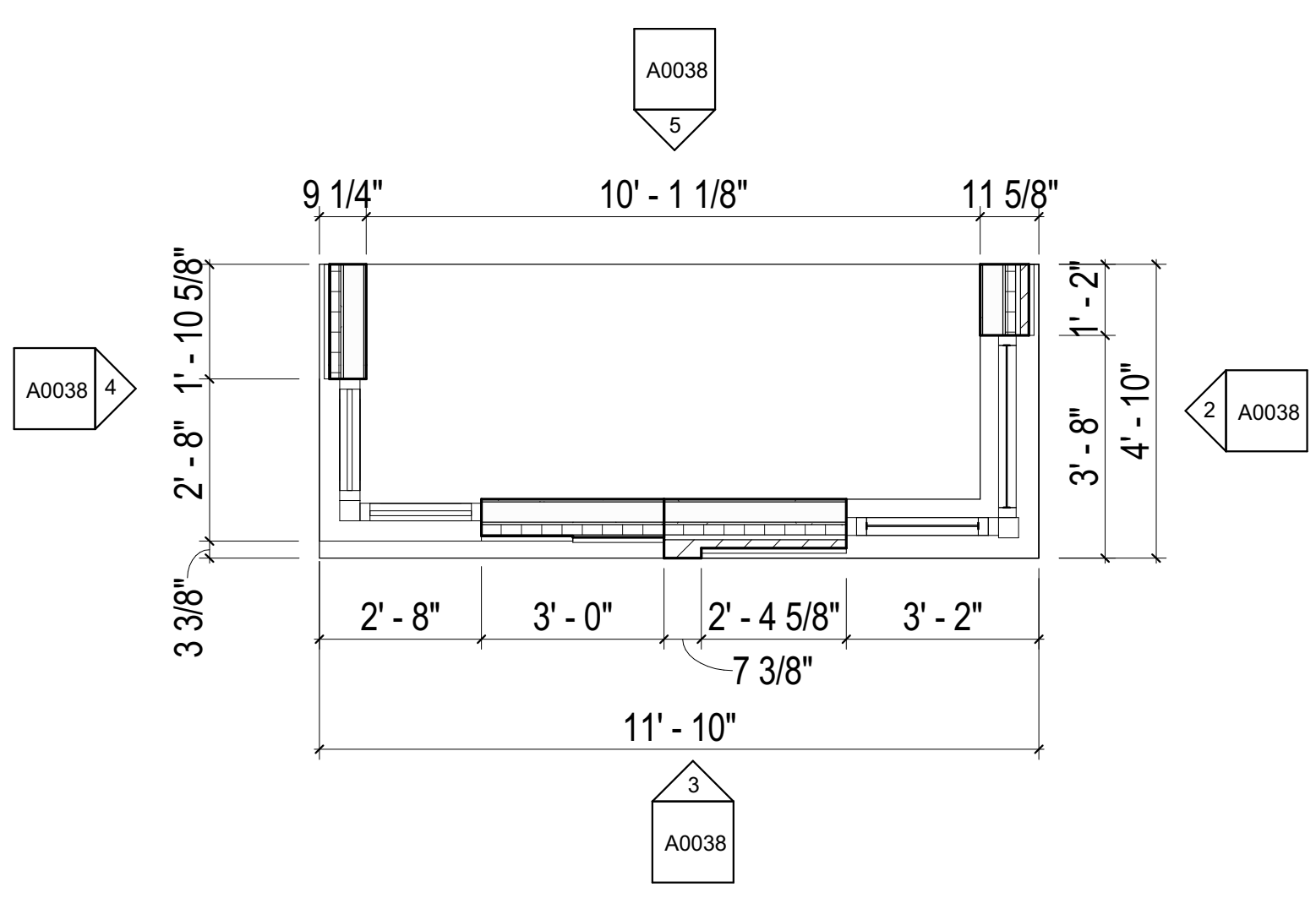

1 Condo Mockup Plan
3/8" = 1'-0"

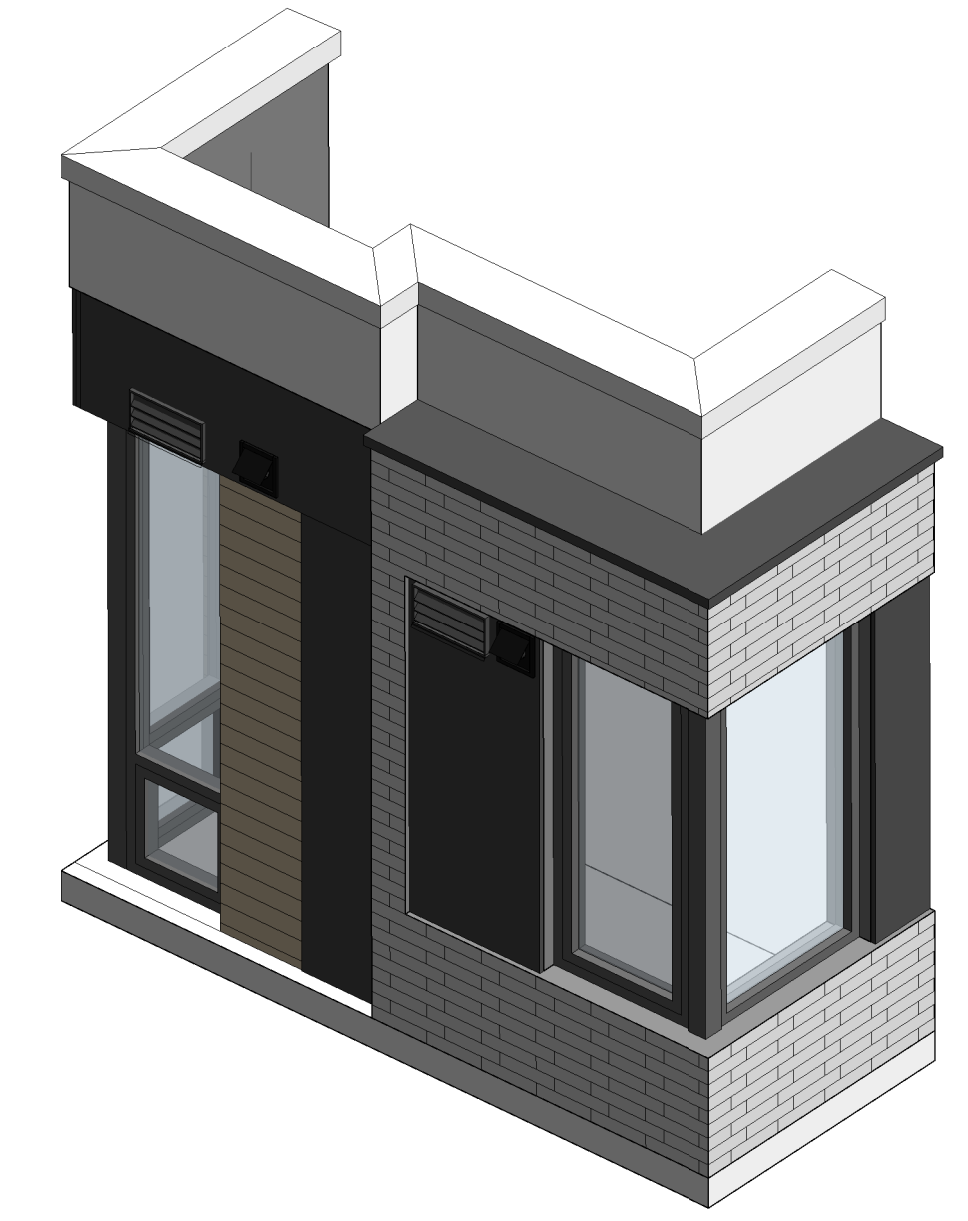

Condo Mockup View 1

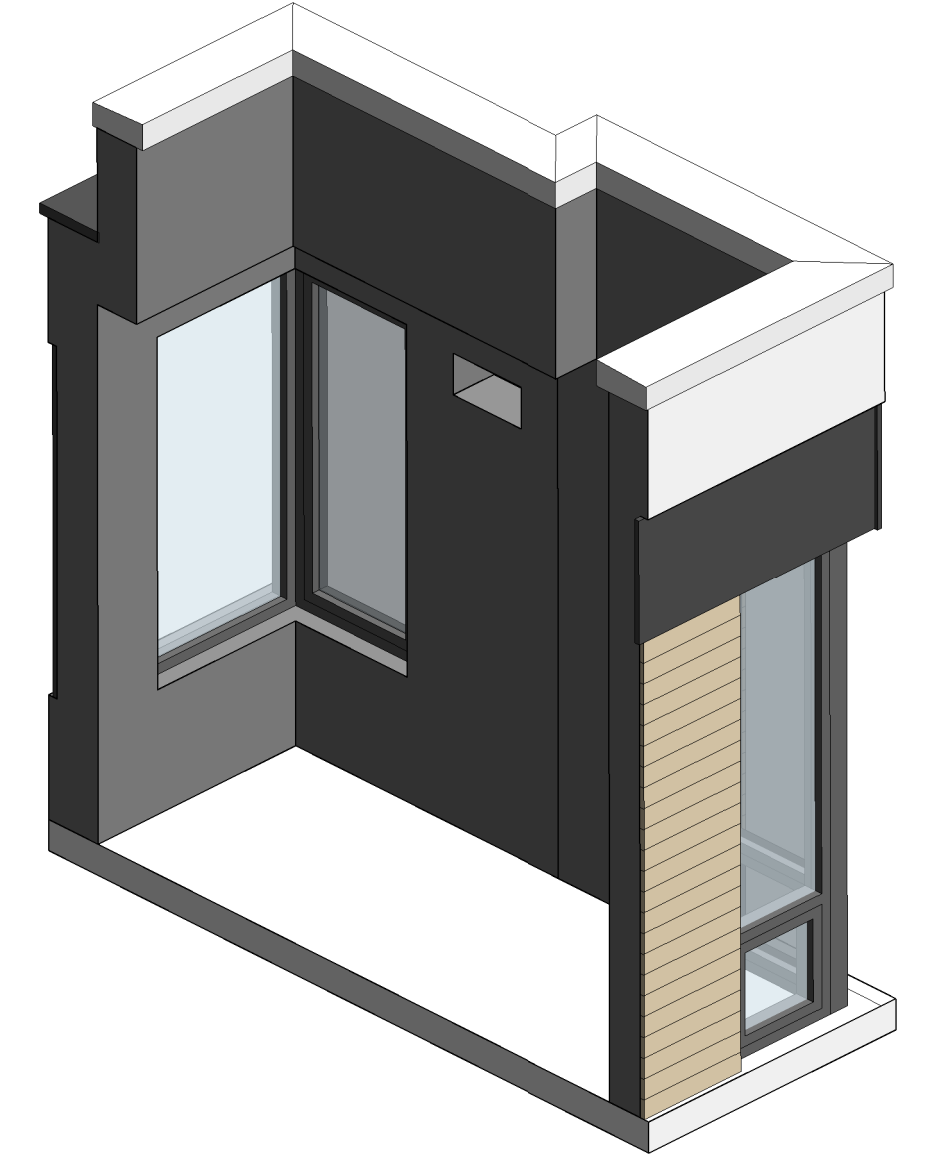

Condo Mockup View 2

ESI
Peer Review

APPROVED
SPECIAL USE PERMIT NO. 2021-10017
DEPARTMENT OF PLANNING & ZONING

DIRECTOR DATE
DEPARTMENT OF TRANSPORTATION & ENVIRONMENTAL SERVICES
SITE PLAN No. _____

DIRECTOR DATE

CHAIRMAN, PLANNING COMMISSION DATE
DATE RECORDED _____

INSTRUMENT NO. DEED BOOK NO. PAGE NO.

TideLock

PROJECT LOCATION
1033, 1055, & 1111 N FAIRFAX ST
ALEXANDRIA, VA 22314

OWNER / DEVELOPER
TIDELOCK PROPERTY OWNER LLC

STRUCTURAL ENGINEER
SK&A | STRUCTURAL ENGINEERS
301.881.1441

MEP ENGINEER
SUMMIT ENGINEERS, INC
703.533.5593

CIVIL ENGINEER
WALTER L. PHILLIPS
703.532.6163

LANDSCAPE ARCHITECT
MAHAN RYKIEL ASSOCIATES
410.235.6001

Key Plan

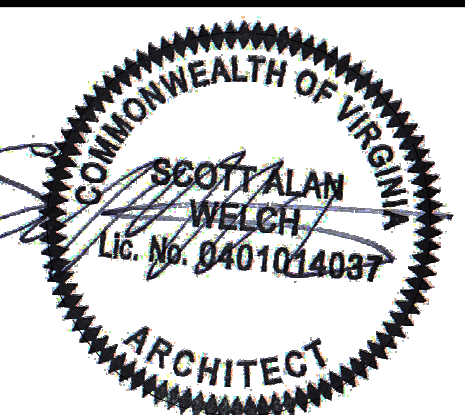

Rental Mockup Panel

PRINCIPAL IN CHARGE
D.A.

PROJECT ARCHITECT
J.S.

DRAWN
S.I., V.S., C.R., R.G., P.B.

DATE
07/11/2022

APPROVED
X.Y.

SCALE:
3/8" = 1'-0"

JOB NO.
18403.38A

DRAWING NO.
A0038.1

APPROVED
SPECIAL USE PERMIT NO. 2021-10017
DEPARTMENT OF PLANNING & ZONING

DIRECTOR DATE
DEPARTMENT OF TRANSPORTATION & ENVIRONMENTAL SERVICES
SITE PLAN No. _____

DIRECTOR DATE

CHAIRMAN, PLANNING COMMISSION DATE
DATE RECORDED _____

INSTRUMENT NO. DEED BOOK NO. PAGE NO.

**ESI
Peer Review**

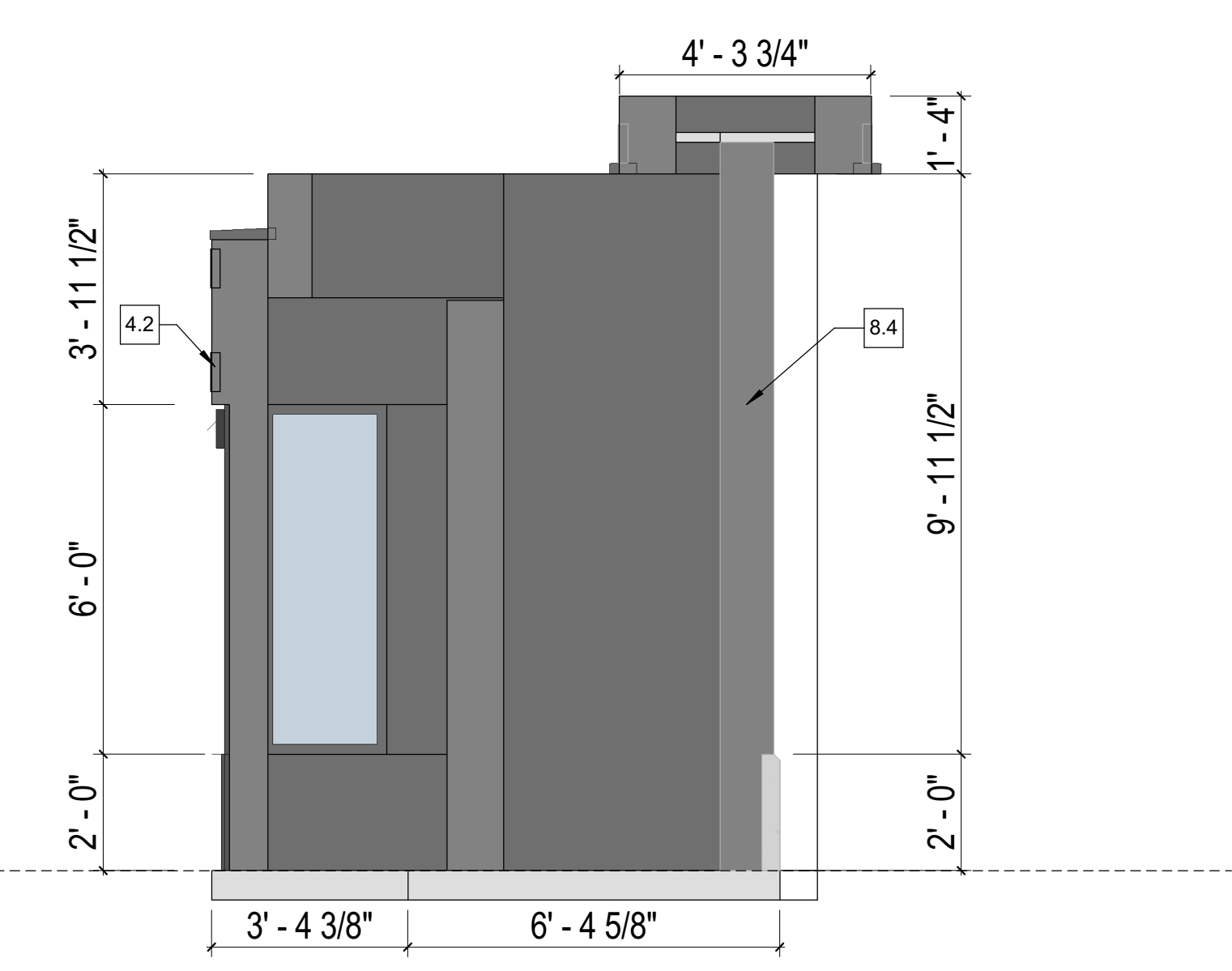

5 Rental Mockup Elevation East
3/8" = 1'-0"

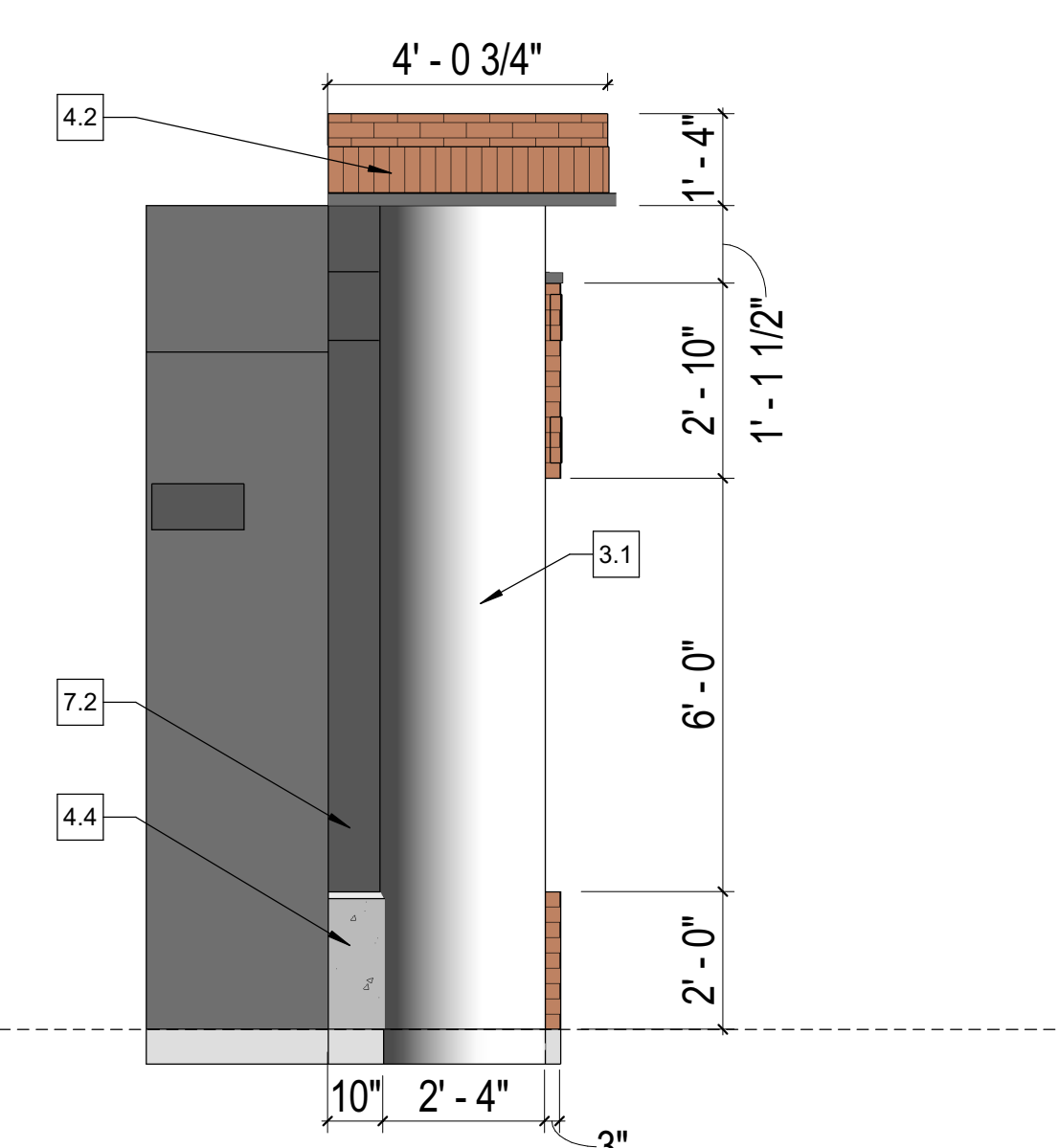

4 Rental Mockup Elevation North
3/8" = 1'-0"

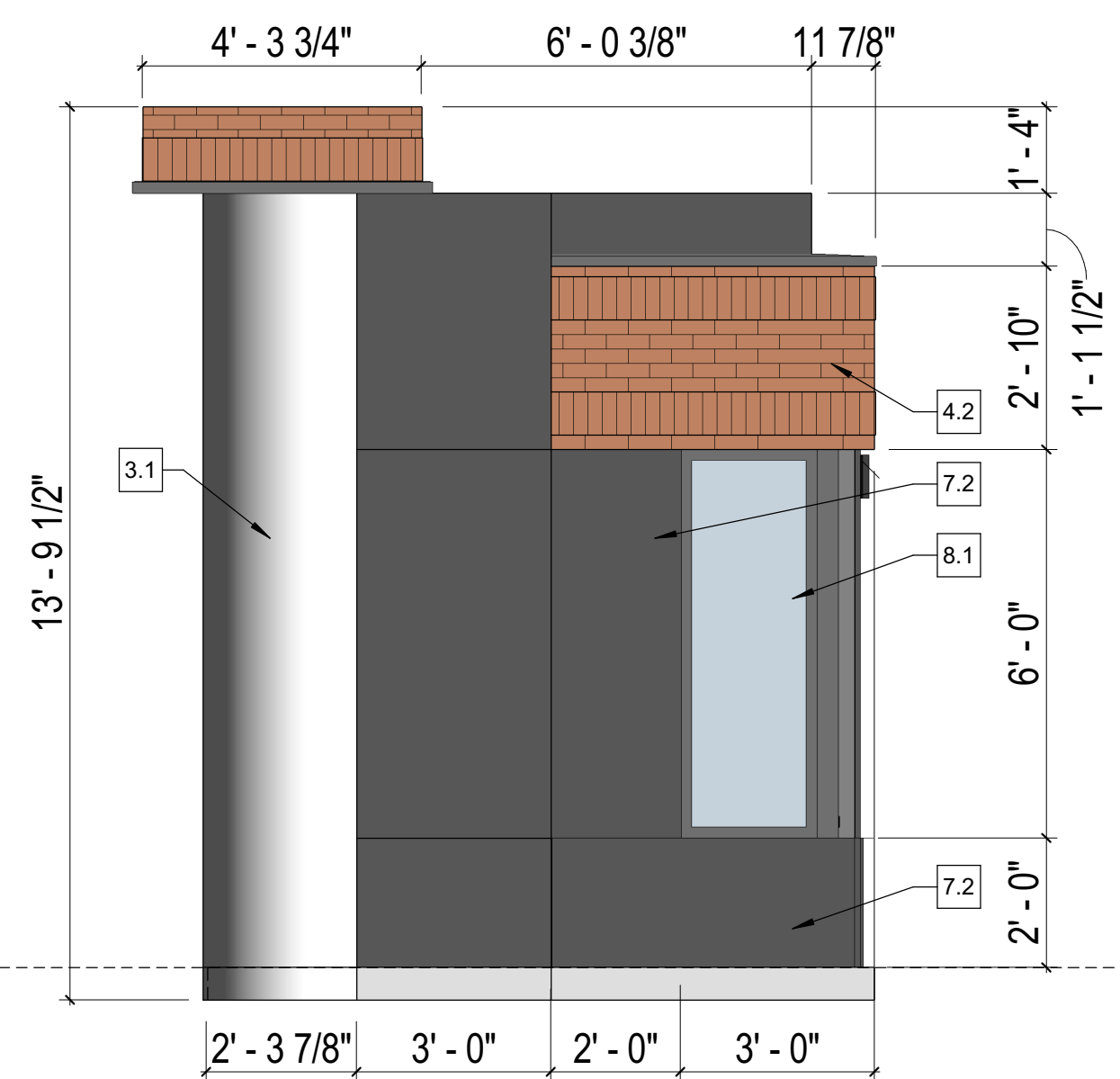

3 Rental Mockup Elevation West
3/8" = 1'-0"

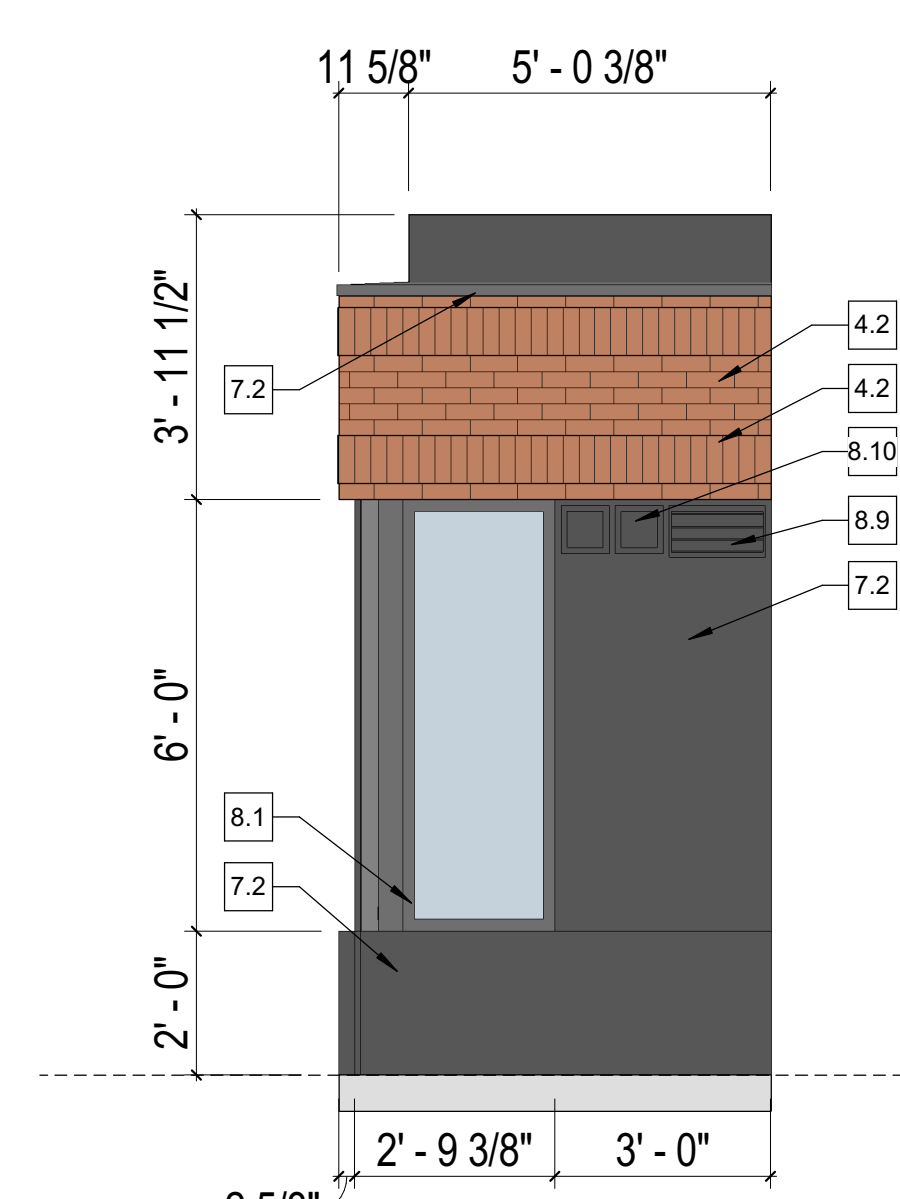

2 Rental Mockup Elevation South
3/8" = 1'-0"

Exterior Materials Keynote Legend	
Key Value	Keynote Text
3.1	CAST STONE COLUMN COVER
4.1	BRICK #1 ACME BRICK STEELE GREY
4.2	BRICK #2 PALMETTO MEDIUM RED SMOOTH
4.3	BRICK #3 ENDICOTT RAVENSWOOD IRONSPOT VELOUR
4.4	ROCKCAST VENEER - COLOR SHADOW
5.1	GLASS RAILING SYSTEM
5.2	PREFINISHED METAL COPING
5.3	METAL MECH SCREEN
5.6	METAL PANEL CANOPY
7.1	METAL PANEL COLOR #1
7.2	METAL PANEL COLOR #2
7.3	METAL PANEL COLOR #3
7.4	METAL PANEL COLOR #4
7.5	METAL PANEL COLOR #5
7.6	CUSTOM ALUMINUM TRIM
8.1	ALUMINUM WINDOW SYSTEM
8.4	STOREFRONT SYSTEM
8.7	BIFOLD DOOR
8.9	MECHANICAL EXHAUST GRILLE
8.10	DRYER EXHAUST

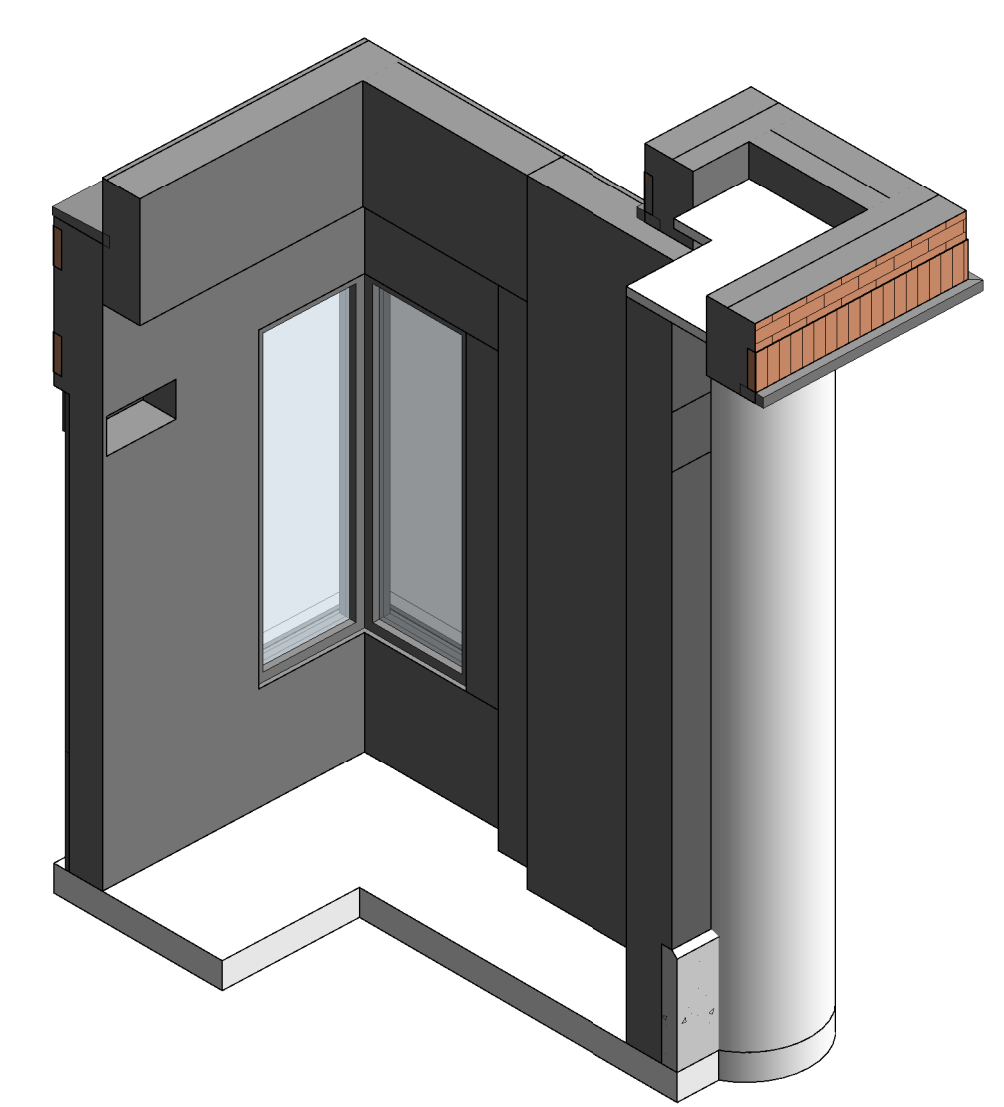

Rental Mockup View 2

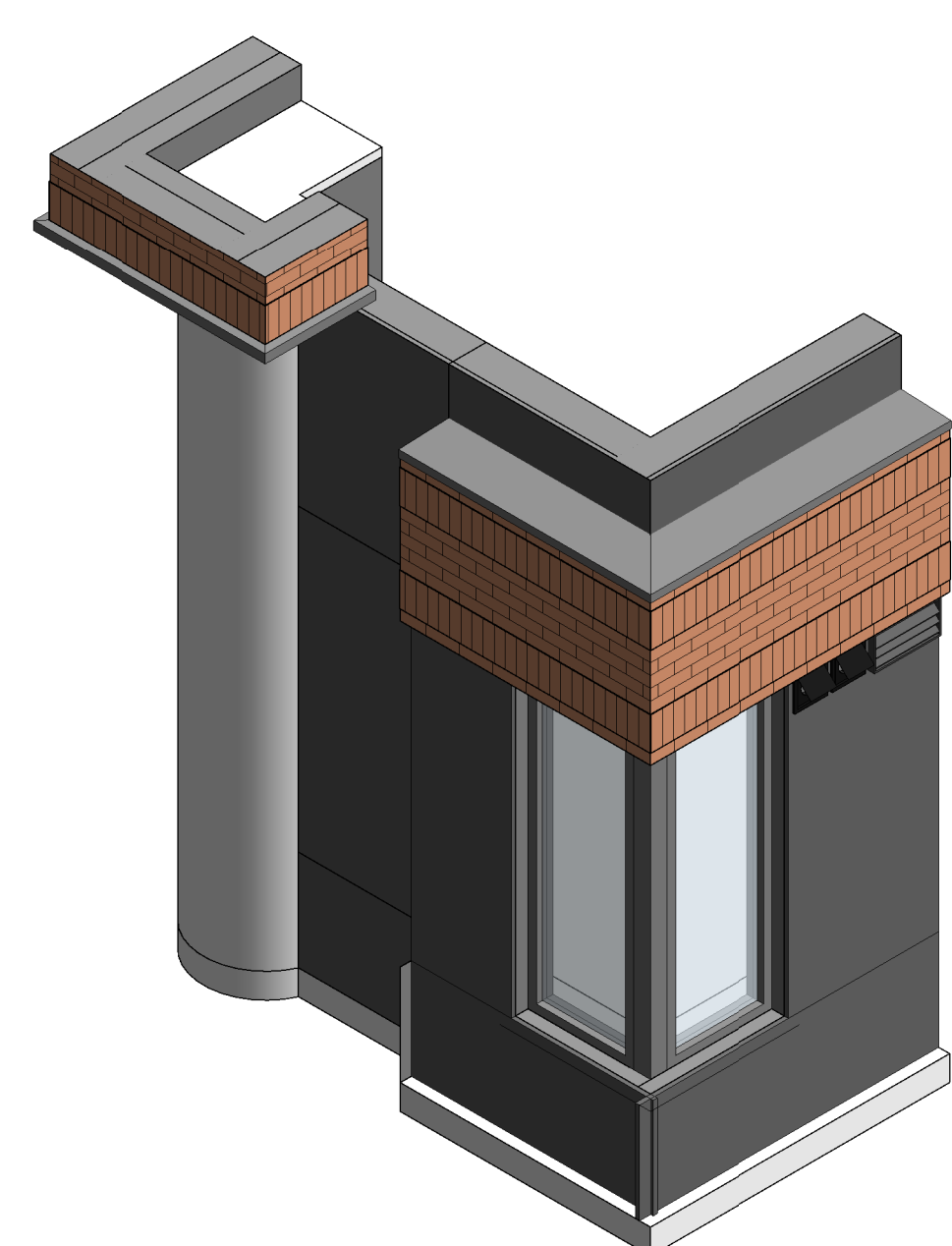

Rental Mockup View 1

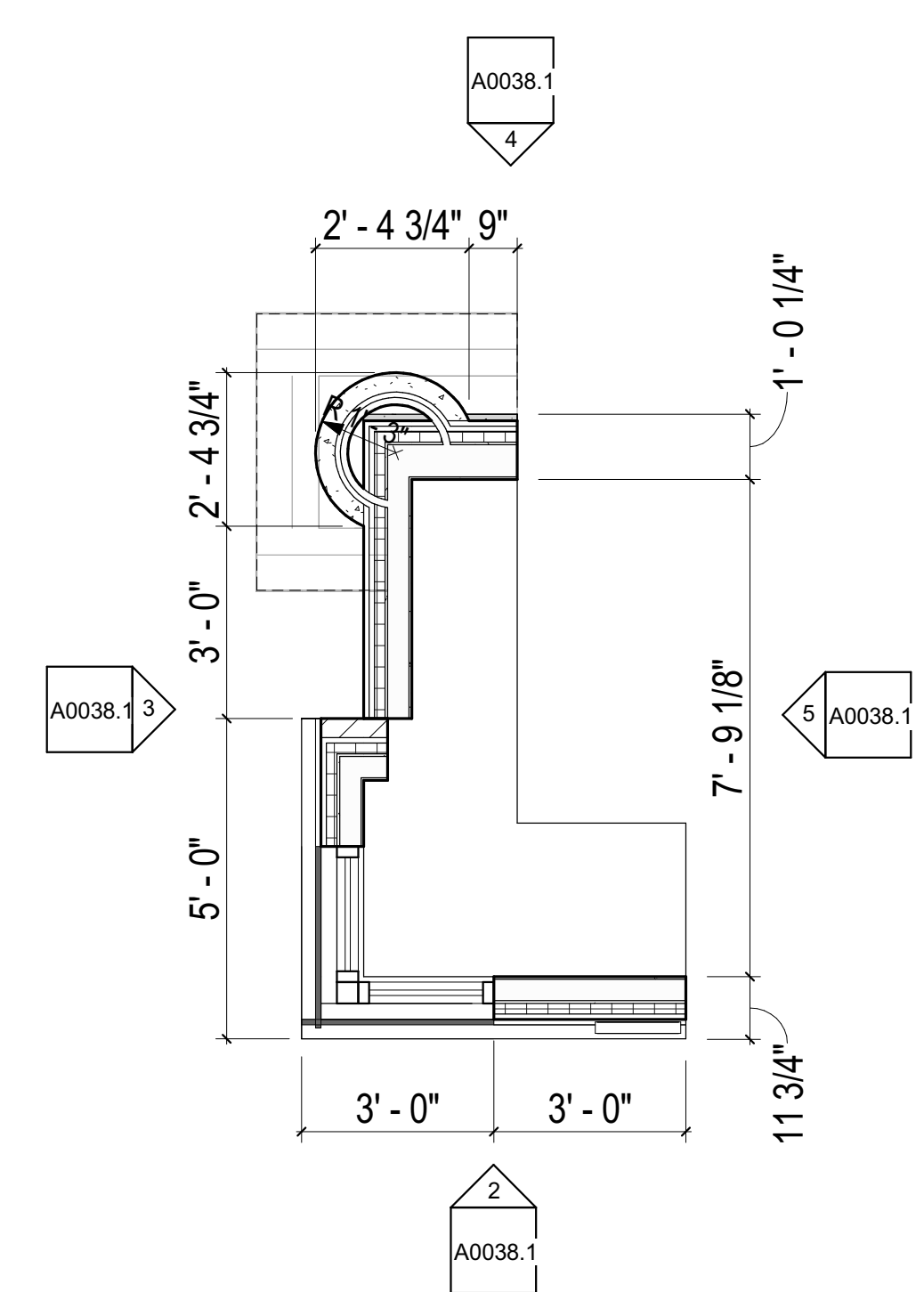

1 4th Floor - Rental Mockup
3/8" = 1'-0"

TideLock

PROJECT LOCATION
1033, 1055, & 1111 N FAIRFAX ST
ALEXANDRIA, VA 22314

OWNER / DEVELOPER
TIDELock PROPERTY OWNER LLC

STRUCTURAL ENGINEER
SK&A | STRUCTURAL ENGINEERS
301.881.1441

MEP ENGINEER
SUMMIT ENGINEERS, INC
703.533.5593

CIVIL ENGINEER
WALTER L. PHILLIPS
703.532.6163

LANDSCAPE ARCHITECT
MAHAN RYKIEL ASSOCIATES
410.235.6001

Exterior Materials Keynote Legend	
Key Value	Keynote Text
3.1	CAST STONE COLUMN COVER
4.1	BRICK #1 ACME BRICK STEELE GREY
4.2	BRICK #2 PALMETTO MEDIUM RED SMOOTH
4.3	BRICK #3 ENDICOTT RAVENSWOOD IRONSPOT VELOUR
4.4	ROCKCAST VENEER - COLOR SHADOW
5.1	GLASS RAILING SYSTEM
5.2	PREFINISHED METAL COPING
5.3	METAL MECH SCREEN
5.6	METAL PANEL CANOPY
7.1	METAL PANEL COLOR #1
7.2	METAL PANEL COLOR #2
7.3	METAL PANEL COLOR #3
7.4	METAL PANEL COLOR #4
7.5	METAL PANEL COLOR #5
7.6	CUSTOM ALUMINUM TRIM
8.1	ALUMINUM WINDOW SYSTEM
8.4	STOREFRONT SYSTEM
8.7	BIFOLD DOOR
8.9	MECHANICAL EXHAUST GRILLE
8.10	DRYER EXHAUST

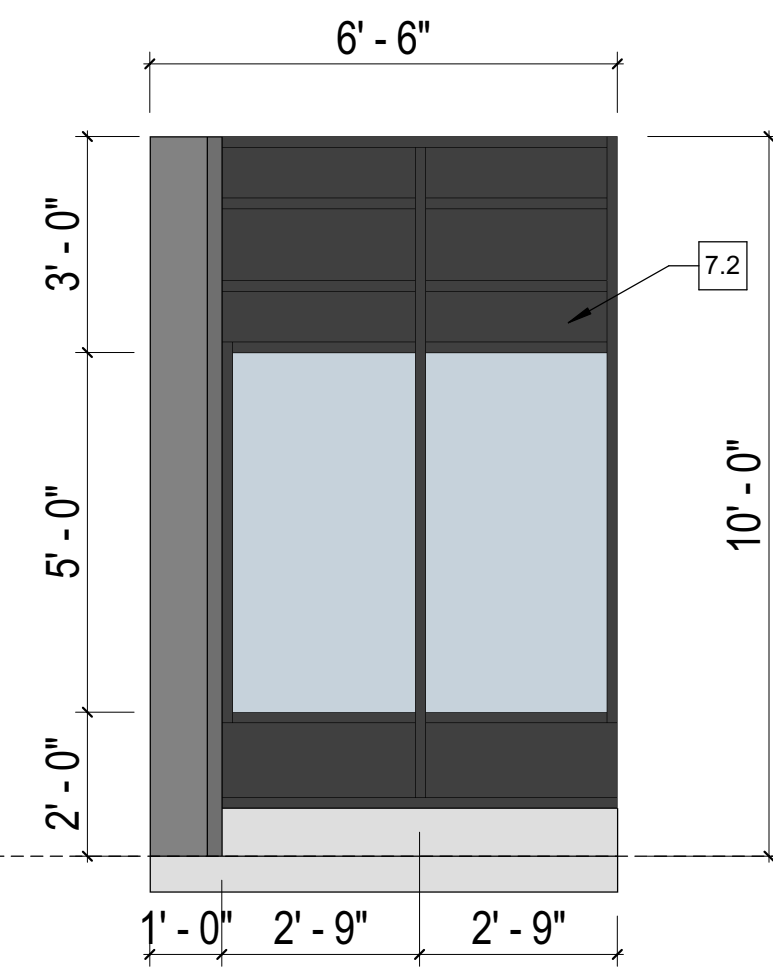

2 Retail Mockup Elevation West
3/8" = 1'-0"

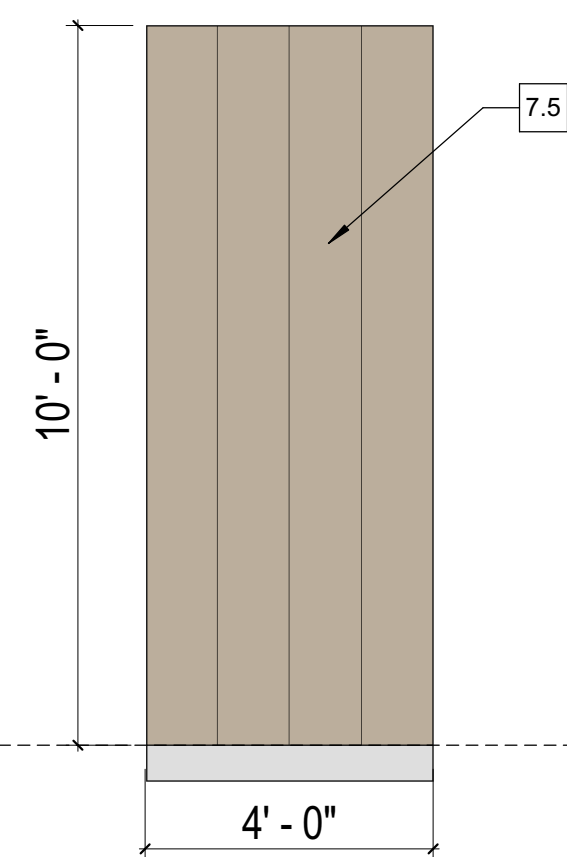

3 Retail Mockup Elevation North
3/8" = 1'-0"

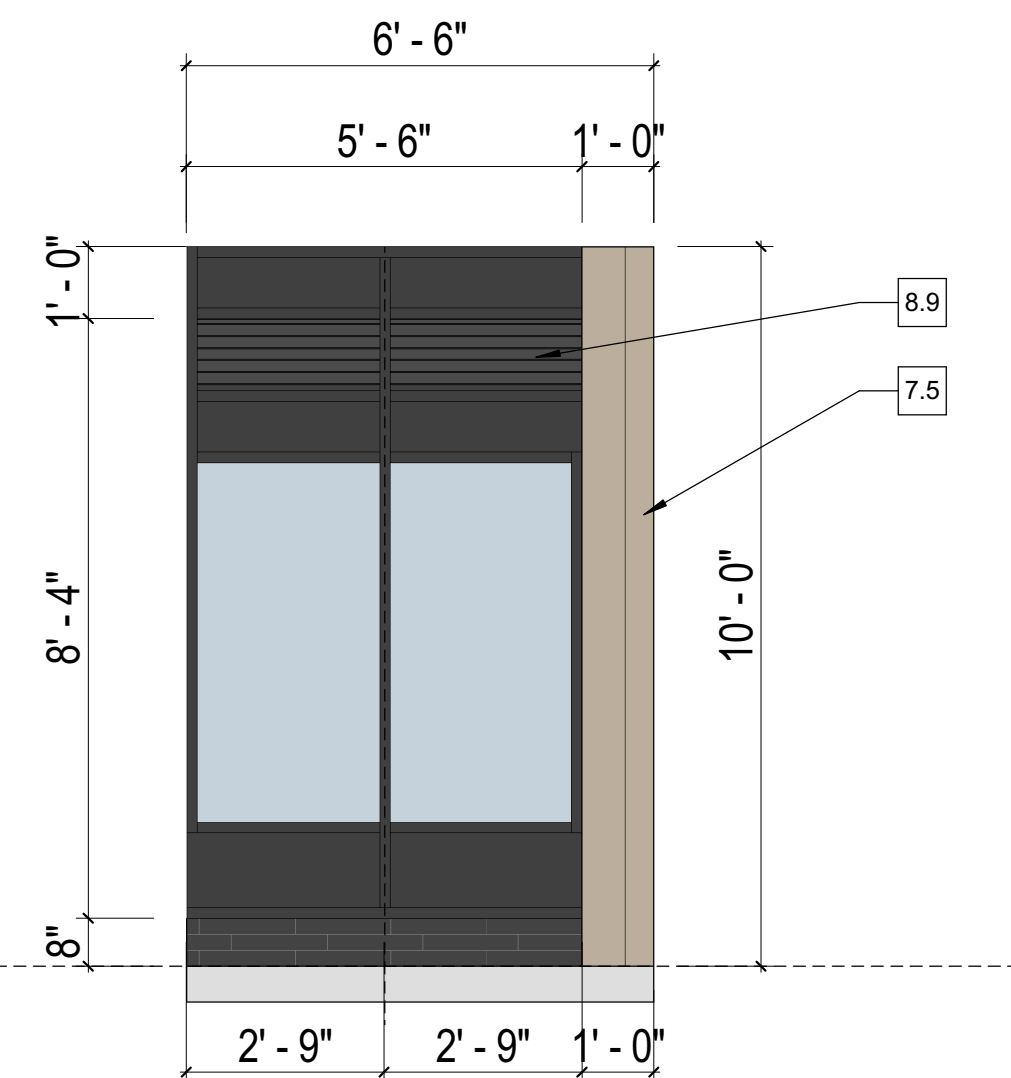

4 Retail Mockup Elevation East
3/8" = 1'-0"

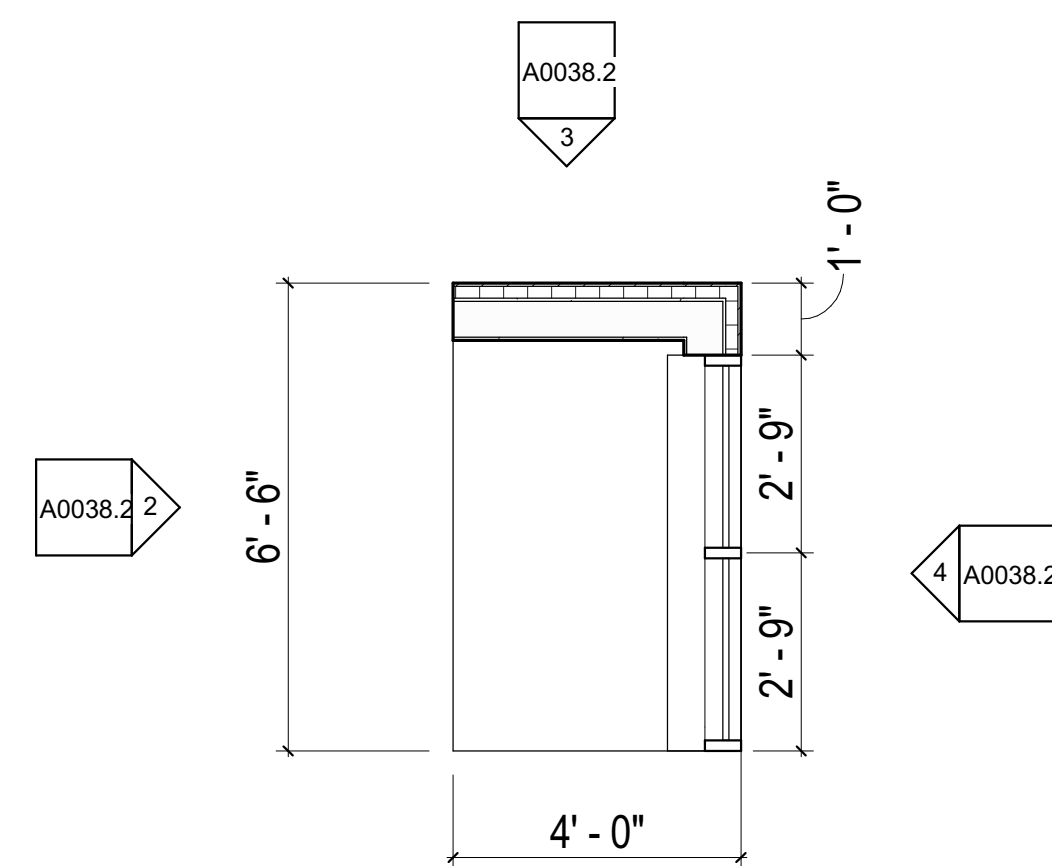

1 Retail Mockup Plan
3/8" = 1'-0"

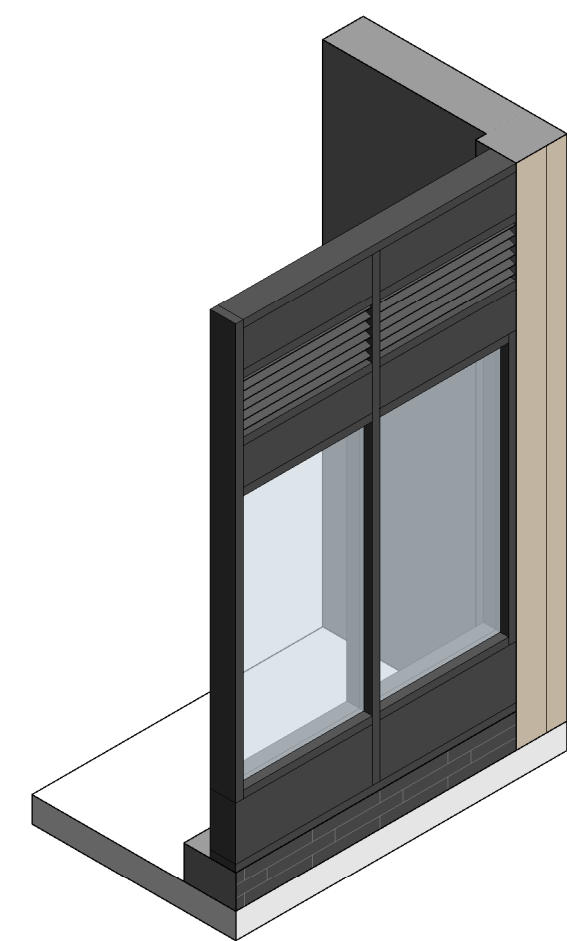

Retail Mockup View 1

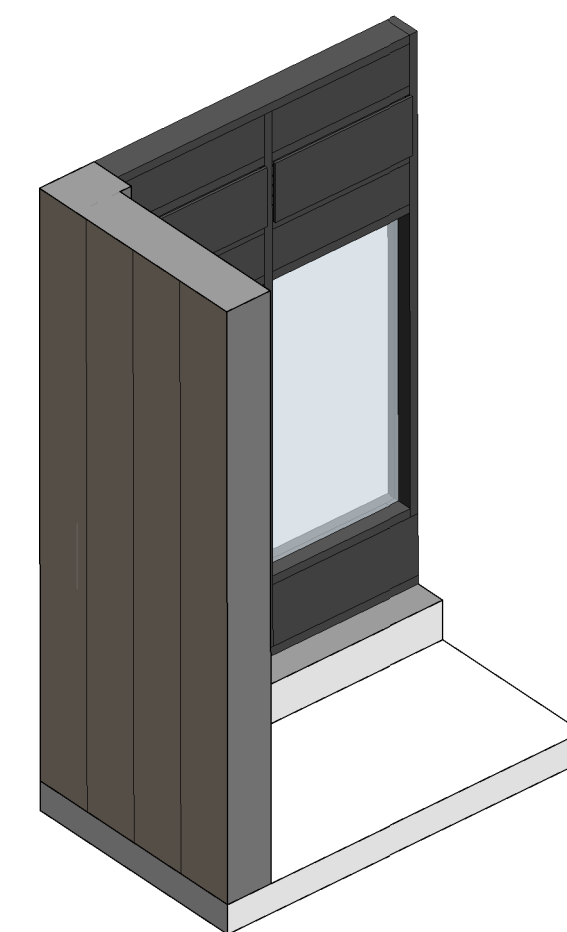

Retail Mockup View 2

Key Plan

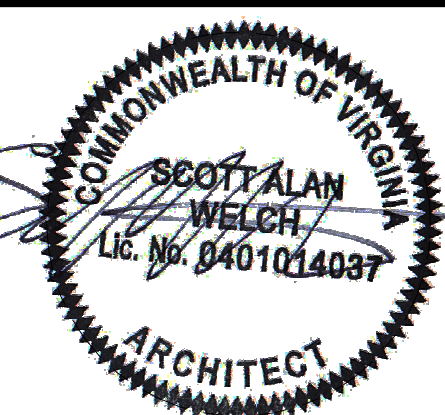

Retail Mockup Panel

PRINCIPAL IN CHARGE
D.A.
PROJECT ARCHITECT
J.S.
DRAWN
S.I., V.S., C.R., R.G., P.B.
DATE
07/11/2022
APPROVED
X.Y.
SCALE:
3/8" = 1'-0"
JOB NO.
18403.38A

DRAWING NO.
A0038.2

APPROVED
SPECIAL USE PERMIT NO. 2021-10017
DEPARTMENT OF PLANNING & ZONING

DIRECTOR _____ DATE _____
DEPARTMENT OF TRANSPORTATION & ENVIRONMENTAL SERVICES
SITE PLAN No. _____

DIRECTOR _____ DATE _____

CHAIRMAN, PLANNING COMMISSION _____ DATE _____
DATE RECORDED _____

INSTRUMENT NO. _____ DEED BOOK NO. _____ PAGE NO. _____

**ESI
Peer Review**