



Madison, Wisconsin

# CITY OF MADISON

## CITY ENGINEERING DIVISION

### DEPARTMENT OF PUBLIC WORKS

# PLAN OF PROPOSED IMPROVEMENT

INDEX OF SHEETS - STREETS

SHEET NO. 1	TITLE
SHEET NO. D1-D2	NOTES AND DETAILS
SHEET NO. P1-P4	PLAN & PROFILE
SHEET NO. U1-U3	UTILITY PLAN & PROFILE
SHEET NO. U-SAN	SANITARY SEWER SCHEDULE
SHEET NO. U-STM	STORM SEWER SCHEDULE
SHEET NO. W1-W3	WATER PLAN & PROFILE
SHEET NO. W4	WATER PLAN OVERVIEW
SHEET NO. W5	WATER ESTIMATE OF MATERIALS

## VILLAGE AT AUTUMN LAKE - PHASE 9

MUNIS NO. 12522  
 CITY PROJECT NO. 12522  
 CITY CONTRACT NO. 8342

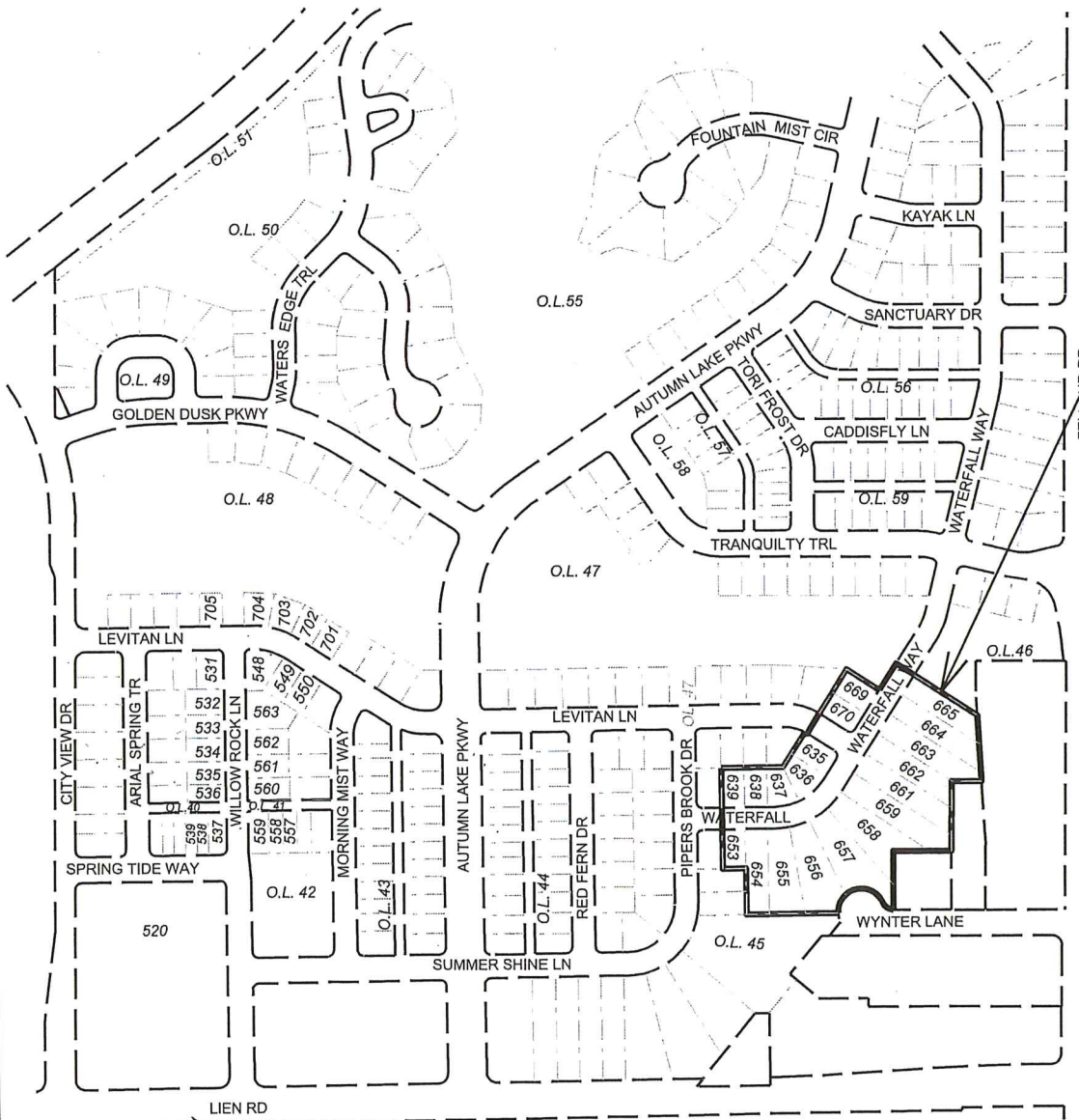

PHASE 9

### PROJECT LOCATION

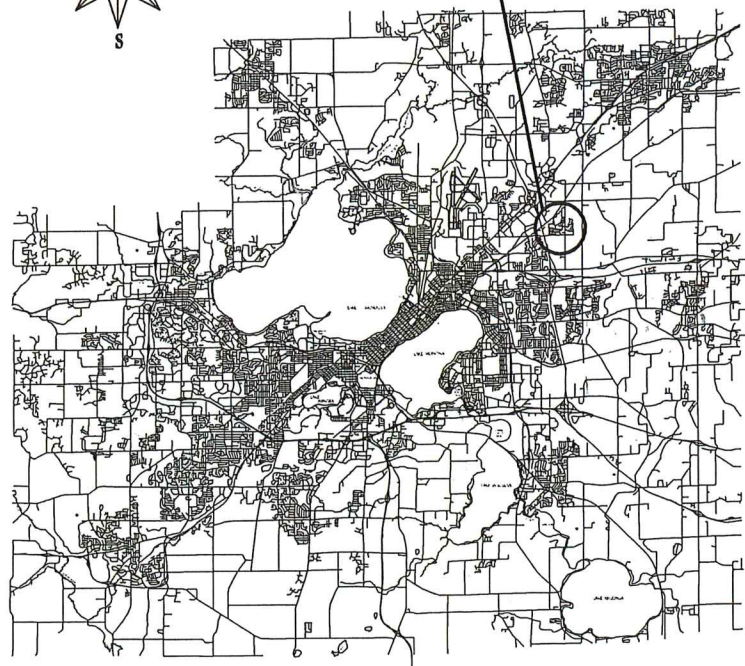
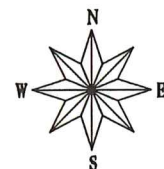

PUBLIC IMPROVEMENT PROJECT APPROVED

MARCH 1, 2019

BY THE COMMON COUNCIL OF MADISON, WISCONSIN

PUBLIC IMPROVEMENT DESIGN APPROVED BY:

*[Signature]* 2/22/19  
 City Engineer Date

SANITARY SEWER DESIGNED BY:

*[Signature]*  
 WISCONSIN PROFESSIONAL ENGINEER  
 MARKO MODER  
 E-33979  
 MADISON WI  
 6/25/19

STORM SEWER DESIGNED BY:

*[Signature]*  
 WISCONSIN PROFESSIONAL ENGINEER  
 GREGORY I. FRIES  
 E-30656  
 MADISON WI  
 6/25/19

STREET GRADES DESIGNED BY:

*[Signature]*  
 WISCONSIN PROFESSIONAL ENGINEER  
 JOHN P. SAPP  
 44054  
 Janesville, WI  
 6-27-19

WATER DESIGNED BY:

*[Signature]*  
 WISCONSIN PROFESSIONAL ENGINEER  
 KELLY B. MIESS  
 E-41821  
 MADISON WI  
 6/25/19

PLOT SCALE:

PLOT NAME:

REV. DATE:

ORIGINATOR: CITY OF MADISON, STREETS DIVISION



THE LOCATION AND INFORMATION FOR PROPOSED NEW TREES, IN THE PUBLIC RIGHT OF WAY OR ON PUBLIC LANDS ARE APPROXIMATE AND ARE SHOWN FOR REFERENCE ONLY. THE LOCATIONS, SPECIFICATIONS AND PLANTING METHODS OF ALL PROPOSED NEW OR REPLACEMENT TREES IN THE PUBLIC RIGHT OF WAY OR ON PUBLIC LANDS SHALL BE APPROVED BY THE CITY FORESTER PRIOR TO INSTALLATION.

NO TREES IN THE RIGHT OF WAY OR ON PUBLIC LANDS SHALL BE TRIMMED, PRUNED, REMOVED OR ADVERSELY AFFECTED IN ANY WAY UNTIL THE DEVELOPER HAS RECEIVED WRITTEN PERMISSION FROM THE CITY ENGINEER OR CITY FORESTER. SAID WRITTEN PERMISSION SHALL INCLUDE LANGUAGE INDICATING THAT SECTION 10.101 OF THE MADISON GENERAL ORDINANCES AND ADMINISTRATIVE PROCEDURE MEMORANDUM NO. 6-2, REFERRING TO NOTIFICATION OF PROPERTY OCCUPANTS AND/OR OWNERS, HAS BEEN COMPLIED WITH.

CONTRACTOR/DEVELOPER SHALL SUBMIT A TRAFFIC CONTROL PLAN TO CITY TRAFFIC ENGINEERING AT LEAST 10 WORKING DAYS PRIOR TO THE START OF WORK. WORK WITHIN THE RIGHT-OF-WAY SHALL NOT BEGIN UNTIL THE TRAFFIC CONTROL PLAN IS APPROVED.

ALL PAVEMENT IN THE LEVITAN LANE AND WATERFALL WAY RIGHTS-OF-WAY SHALL BE TYPE A PAVEMENT PER STANDARD DETAIL DRAWING 4.02.

UNDERDRAINS SHALL BE INSTALLED, PER STANDARD DETAIL DRAWING 4.05 FOR 75' ON EACH SIDE OF THE LOW POINT, OR TO THE NEAREST CURB HIGH POINT. ALL UNDERDRAIN SHALL BE WRAPPED.

ALL GUTTERS SHALL DRAIN WITH A MINIMUM GRADES OF 0.5% TOWARD STORM SEWER INLETS.

ALL DITCHES SHALL DRAIN WITH A MINIMUM GRADES OF 0.5%

THE CROSS SLOPE OF SIDEWALKS AND BARRIER FREE SIDEWALK CURB RAMPS SHALL TYPICALLY BE 1.5%. THE LONGITUDINAL GRADE OF BARRIER FREE SIDEWALK CURB RAMPS SHALL NOT EXCEED 8.33%. ALL SIDEWALK RAMPS SHALL BE CONSTRUCTED ACCORDING TO S.D.D. 3.03. AT ALL OTHER LOCATIONS THE LONGITUDINAL GRADE OF SIDEWALKS SHALL NOT EXCEED 5.0 % OR THE ADJACENT STREET GRADE WHICHEVER IS GREATER NOR BE LESS THAN 0.5% AND SHALL DRAIN TOWARD STORM SEWER INLETS. SIDE SLOPES WITHIN TEN FEET OF A PUBLIC SIDEWALK SHALL NOT EXCEED 4.00:1. ALL SIDEWALK AND SIDEWALK RAMP ELEVATIONS AND GRADES SHALL BE FIELD VERIFIED AND SET TO COMPLY WITH THE CITY OF MADISON STANDARD SPECIFICATIONS AND THE A.D.A. GUIDELINES.

OBTAIN A PRINT OUT OF THE ALIGNMENT FROM THE CITY ENGINEER PRIOR TO STAKING THIS PROJECT.

CURB STATION AND OFFSETS SHALL BE TO THE FACE OF CURB UNLESS OTHERWISE INDICATED. CURB ELEVATIONS SHALL BE TO THE TOP OF CURB (OR EXTENDED TOP OF CURB FOR DRIVEWAYS OR RAMPS) UNLESS OTHERWISE INDICATED.

POWER POLES AND OTHER OBSTRUCTIONS SHALL BE MOVED TO PROVIDE 2 FEET MINIMUM OF CLEAR DISTANCE FROM ANY FACE OF CURB OR EDGE OF SIDEWALK.

ANY INFORMATION SHOWN ON THIS PLAN, WHICH IS NOT PART OF THIS PROJECT, IS PRELIMINARY AND NOT FOR CONSTRUCTION.

THERE MAY BE EXISTING UTILITIES OR OTHER FEATURES WHICH ARE EITHER NOT SHOWN OR SHOWN INCORRECTLY ON THIS PLAN. IT IS THE RESPONSIBILITY OF THE DEVELOPER TO LOCATE AND IDENTIFY ALL UTILITIES AND TOPOGRAPHY WHICH MAY AFFECT THE CONSTRUCTION OF THESE IMPROVEMENTS.

ALL PERMANENT SIGNING AND POSTING WILL BE DETERMINED AND PROVIDED BY THE TRAFFIC ENGINEERING DIVISION, FOLLOWING CONSTRUCTION OF THESE IMPROVEMENTS.

THE DEVELOPER SHALL PROVIDE, INSTALL AND MAINTAIN ALL STREET END BARRICADES, SIGNING AND TRAFFIC CONTROL, AS REQUIRED BY THE CITY TRAFFIC ENGINEER.

PAVEMENT SAWCUTS SHALL BE AS DIRECTED BY THE CITY CONSTRUCTION ENGINEER. SAWCUTS SHOWN ON THE PLAN ARE APPROXIMATE.

CURB ON CUL DE SACS SHALL BE INSTALLED ACCORDING TO SDD 3.05.

CONVENTIONAL SIGNS

FIELD VERIFY ALL UTILITY LOCATIONS

GAS ——— G ———

STORM SEWER ——— ST ———

SANITARY SEWER ——— SAN ———

WATER ——— W ———

OVERHEAD ELECTRIC ——— OH ———

POWER POLE 

ADA COMPLIANT RAMP W/  
DETECTABLE WARNING FIELD 

COMBUSTIBLE FLUIDS 

PLOT SCALE:

PLOT NAME:

REV. DATE:

ORIGINATOR: CITY OF MADISON, STREETS DIVISION

DETAIL

TYPICAL SECTION

CITY OF MADISON

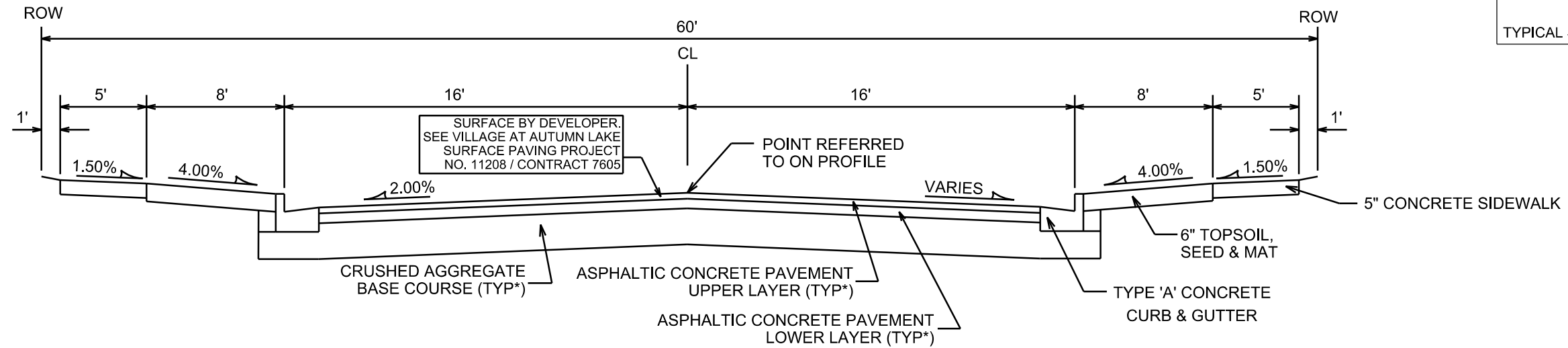

**TYPICAL SECTION**

LEVITAN LANE  
NOT TO SCALE

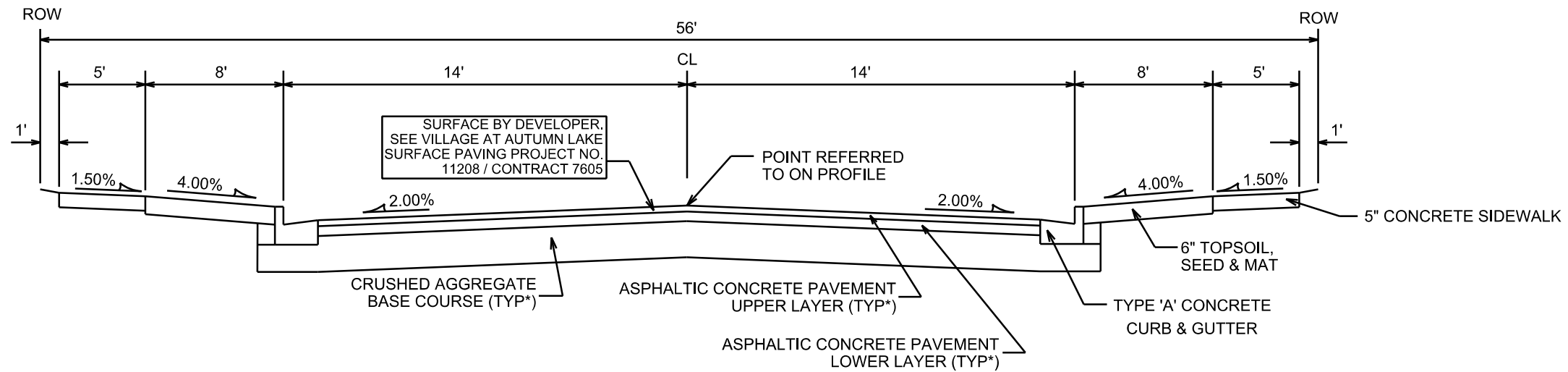

**TYPICAL SECTION**

WATERFALL WAY  
NOT TO SCALE

†CITY OF MADISON MINIMUM PAVEMENT DESIGN

TYPE	CRUSHED AGGREGATE BASE COURSE		ASPHALTIC CONCRETE PAVEMENT			
	LOWER LAYER GRADATION 1	UPPER LAYER GRADATION 2	LOWER LAYER		UPPER LAYER	
			TYPE	THICKNESS	TYPE	THICKNESS
A	6"	6"	4 LT 58-28 S	1.75"	4 LT 58-28 S	1.75"
B	6"	6"	3 LT 58-28 S	2.50"	4 LT 58-28 S	2.00"
C	6"	6"	3 MT 58-28 S/H 3 HT 58-28 H	3.50"	4 MT 58-28 S/H 4 HT 58-28 H	2.00"

NOTES:  
\* LEVITAN LN AND WATERFALL WAY TO BE CONSTRUCTED AS TYPE 'A' PAVEMENT;  
PER CITY OF MADISON MINIMUM PAVEMENT DESIGN†

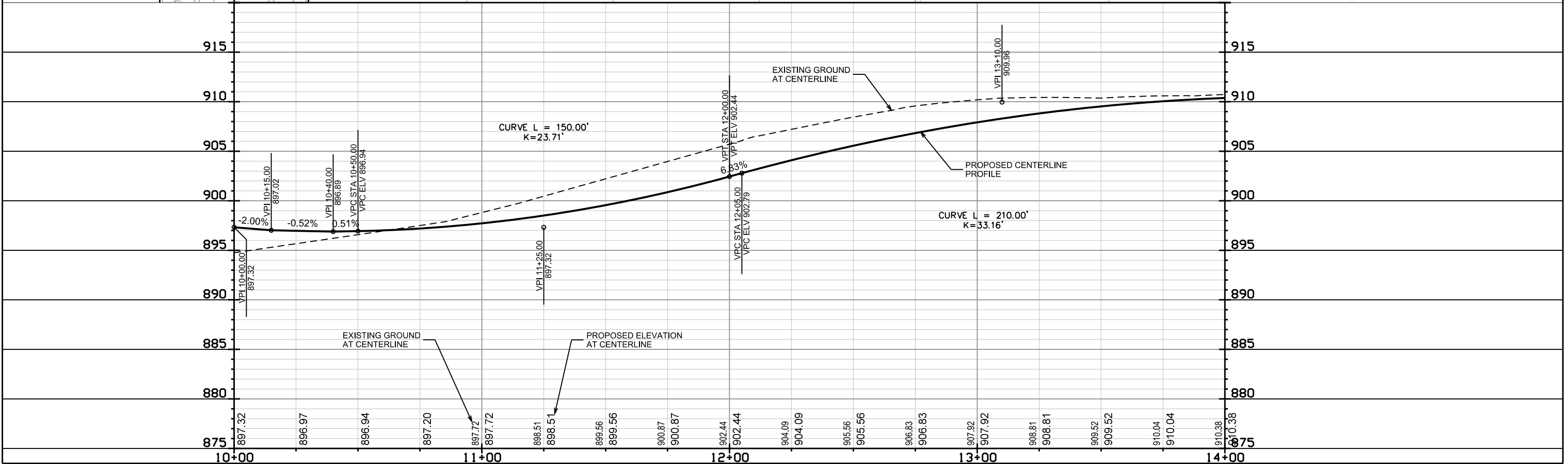
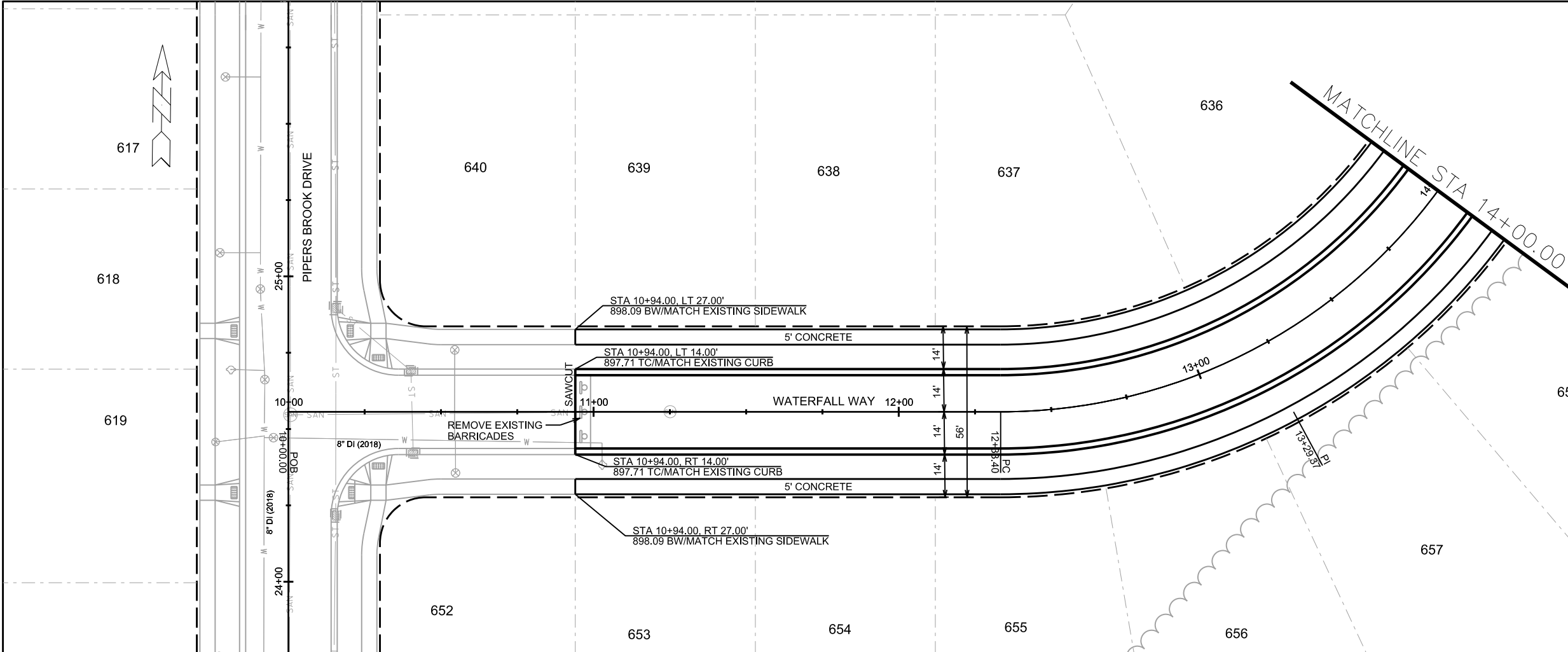

PLOT SCALE:  
PLOT NAME:  
REV. DATE:  
ORIGINATOR: CITY OF MADISON, STREETS DIVISION

PLAN AND PROFILE  
WATERFALL WAY CITY OF MADISON

- NOTES:  
1. 5' CONCRETE SIDEWALK  
2. END OF ROAD SIGNING PER S.D.D. 6.29A  
3. 5' ASPHALT TRANSITION FROM BACK OF CURB TO BACK OF CURB. CONSTRUCT ASPHALT CURB HEAD AND FLOWLINE TO MATCH CONCRETE CURB.  
4. UNDERDRAIN

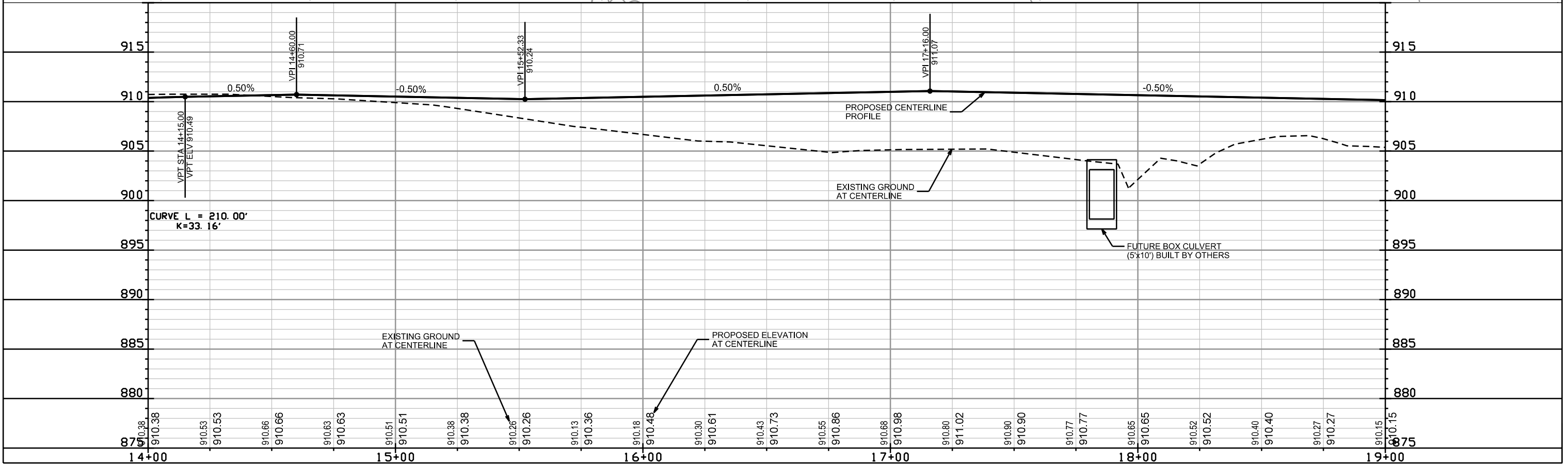
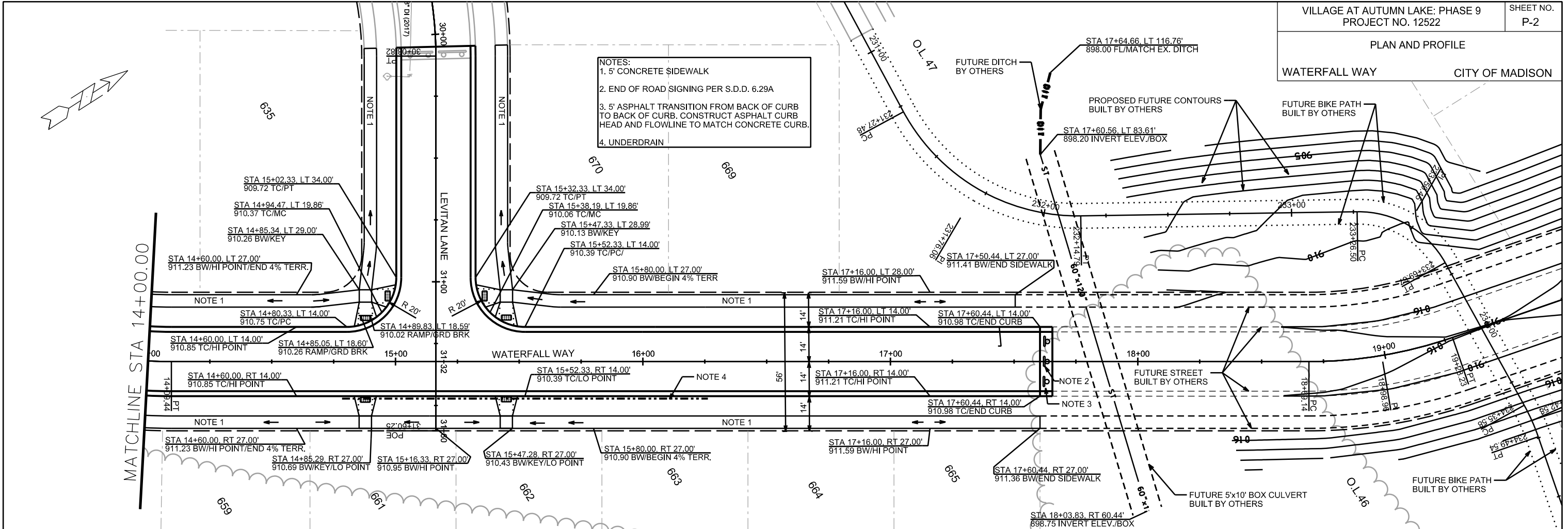

PLOT SCALE: \_\_\_\_\_

PLOT NAME: \_\_\_\_\_

REV. DATE: \_\_\_\_\_

ORIGINATOR: CITY OF MADISON, STREETS DIVISION

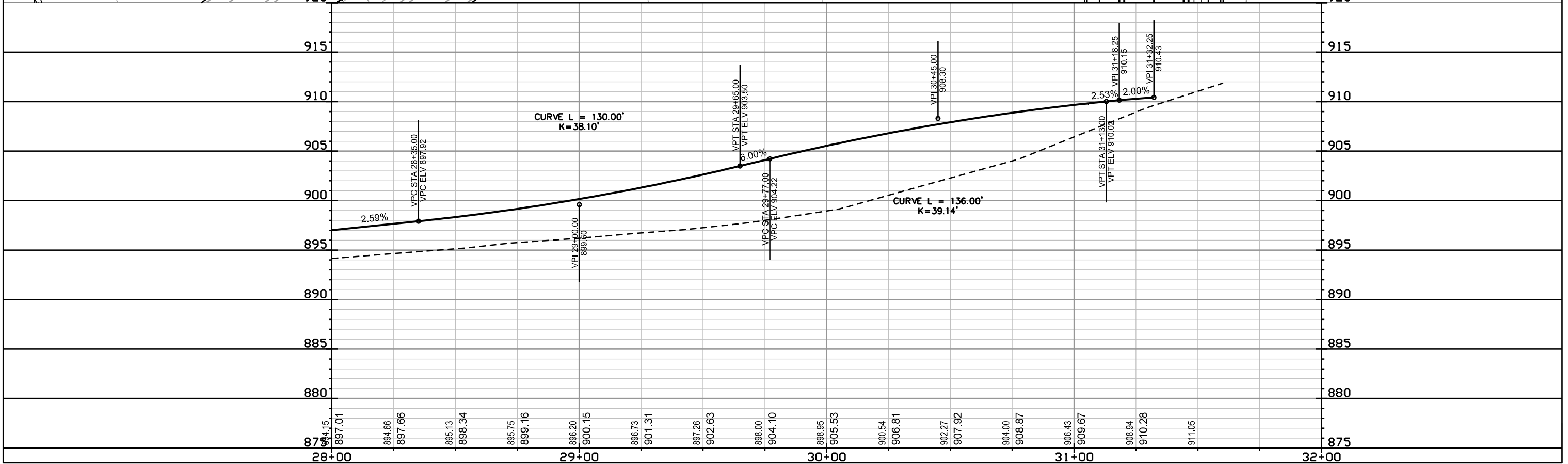
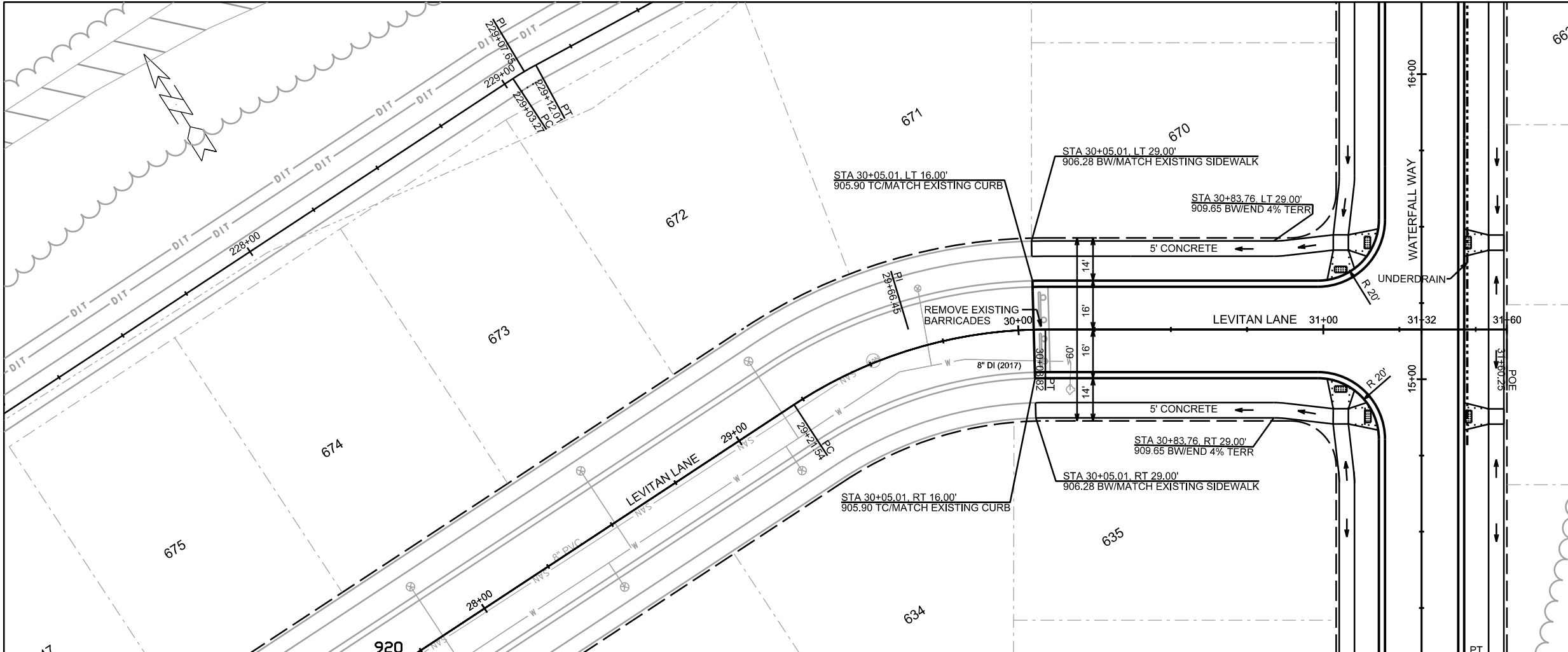

PLOT SCALE: \_\_\_\_\_

PLOT NAME: \_\_\_\_\_

REV. DATE: \_\_\_\_\_

ORIGINATOR: CITY OF MADISON, STREETS DIVISION

PLAN AND PROFILE  
O.L. 47 - FUTURE BIKE PATH CITY OF MADISON

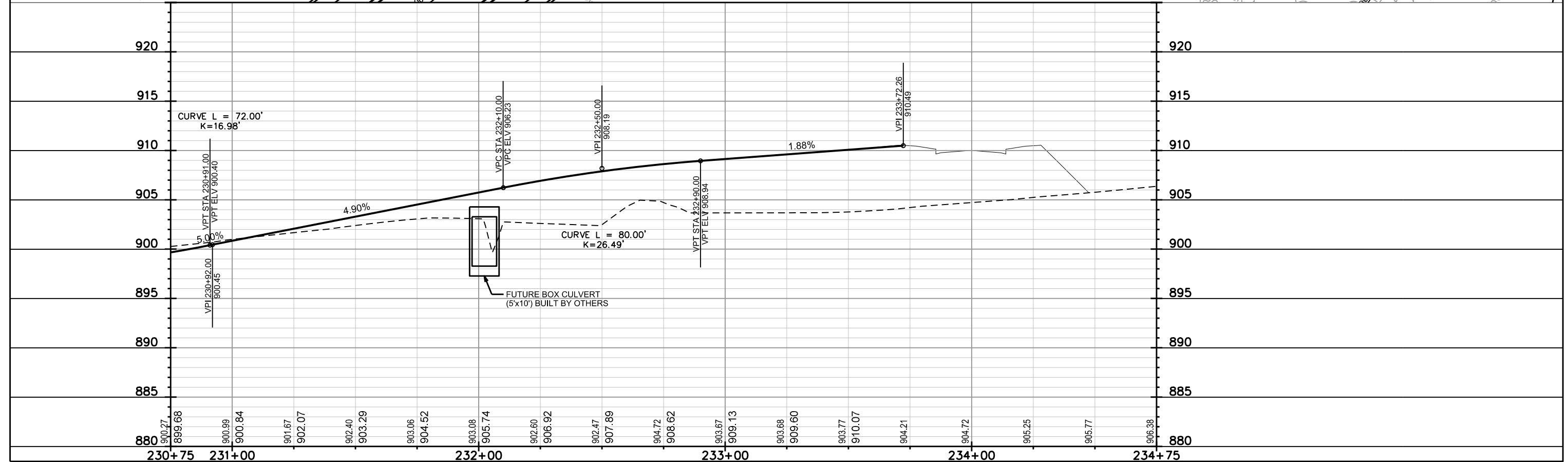
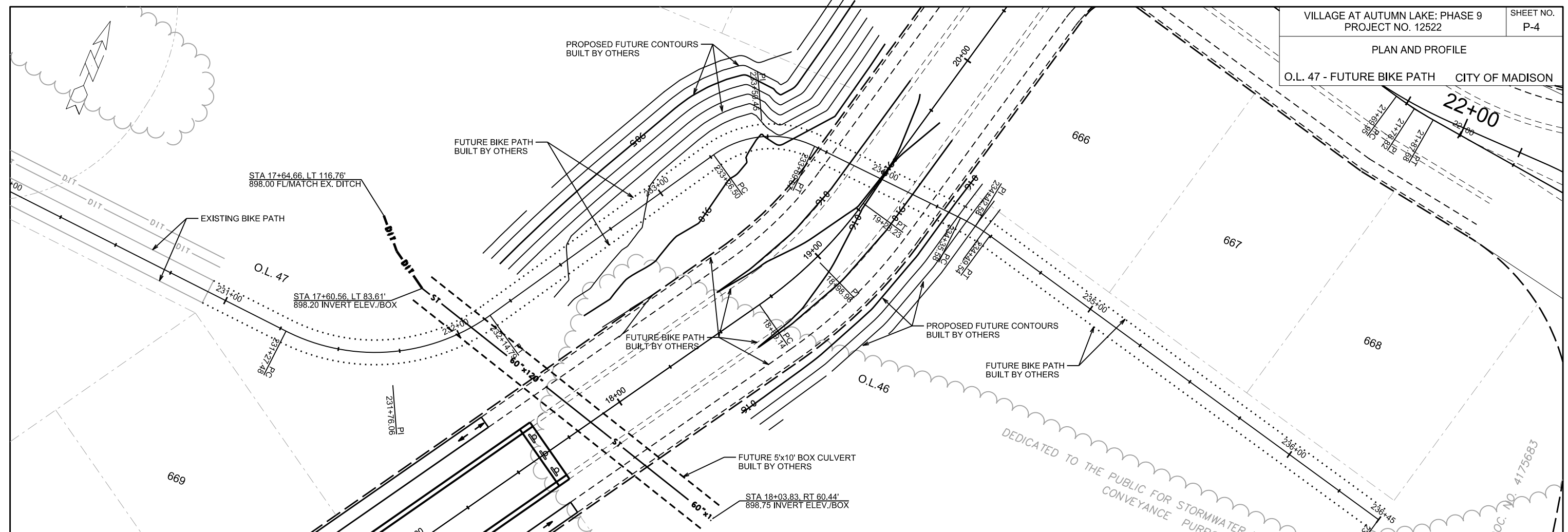

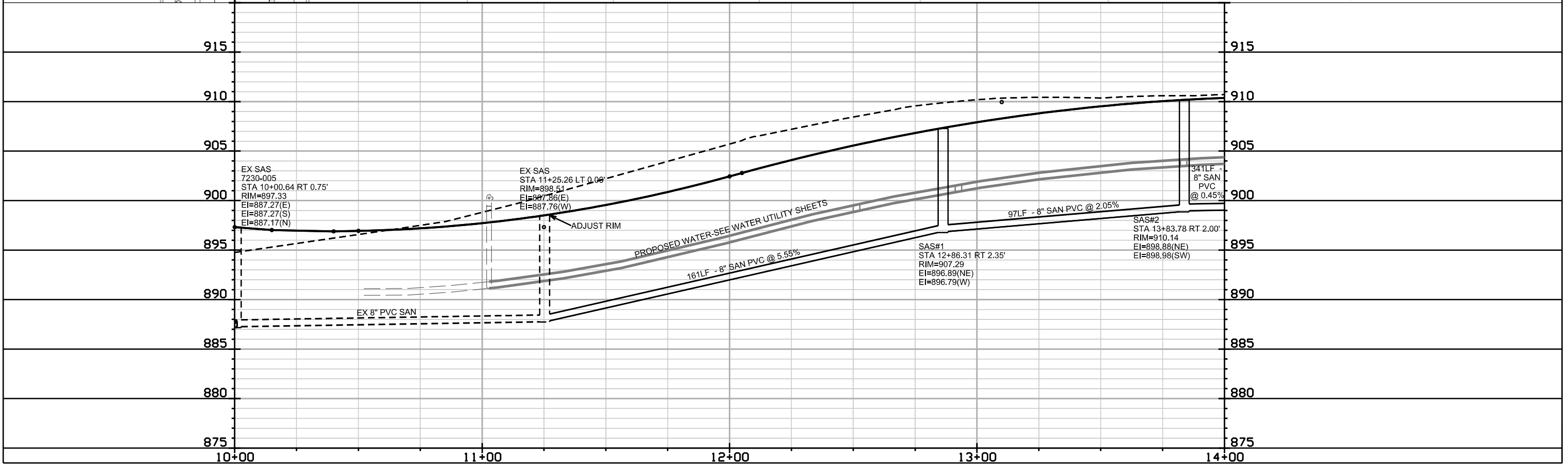
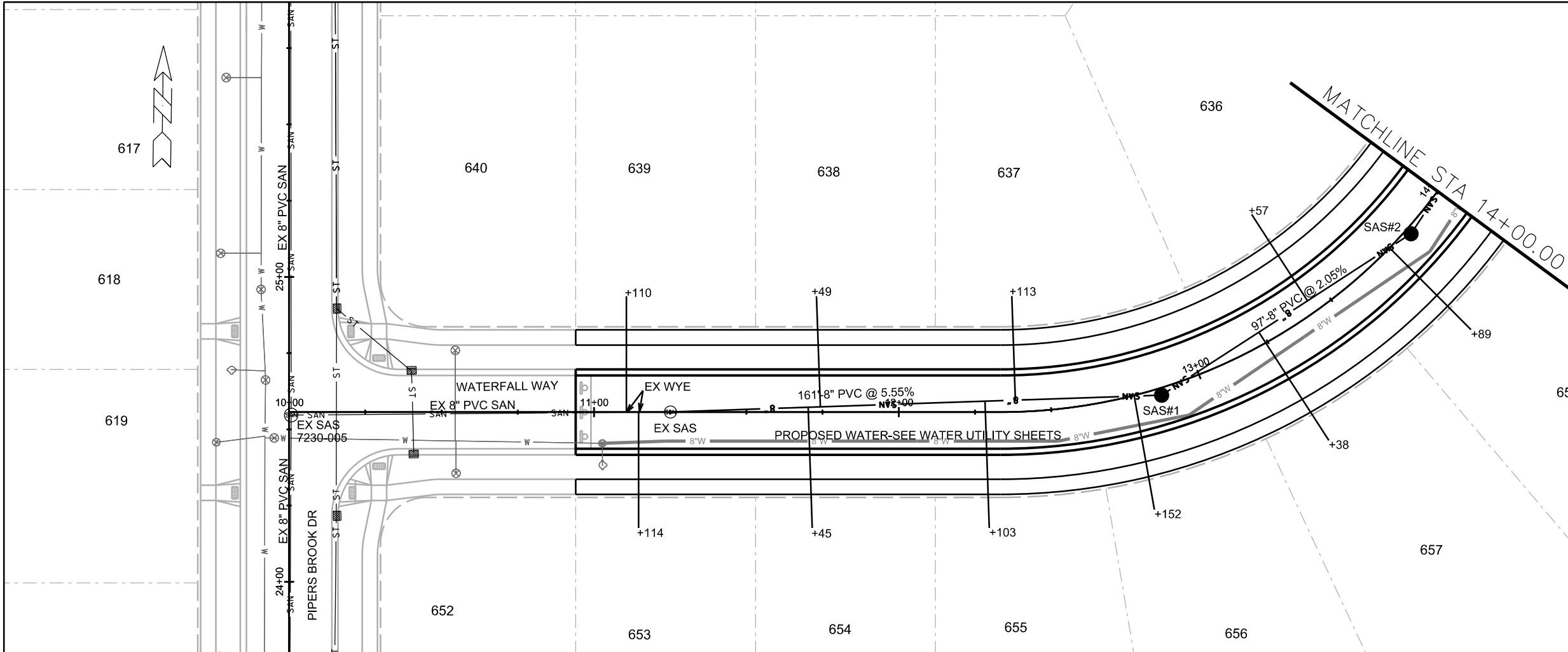

PLOT SCALE: \_\_\_\_\_

PLOT NAME: \_\_\_\_\_

REV. DATE: \_\_\_\_\_

ORIGINATOR: CITY OF MADISON, STREETS DIVISION



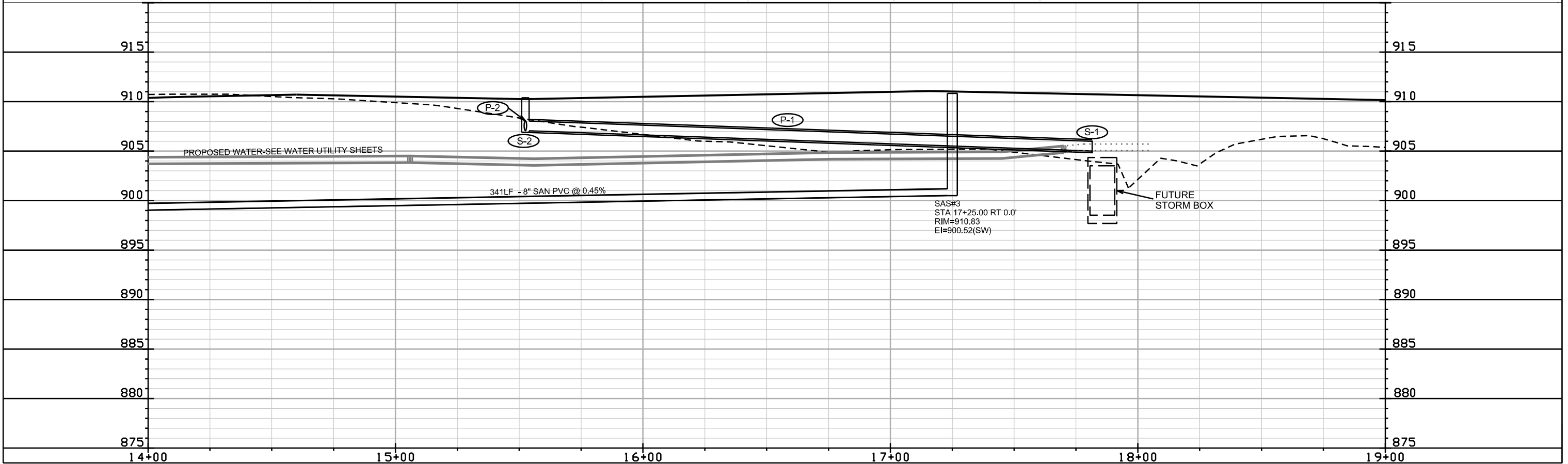
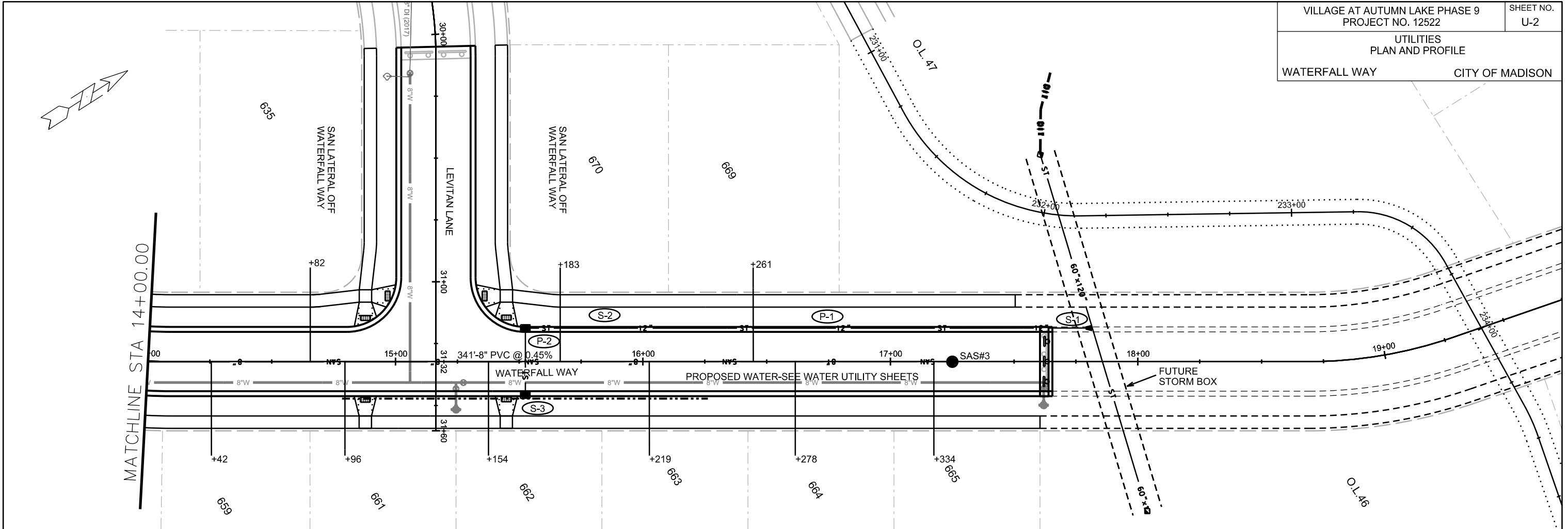

PLOT SCALE: \_\_\_\_\_

PLOT NAME: \_\_\_\_\_

REV. DATE: \_\_\_\_\_

ORIGINATOR: CITY OF MADISON, STREETS DIVISION

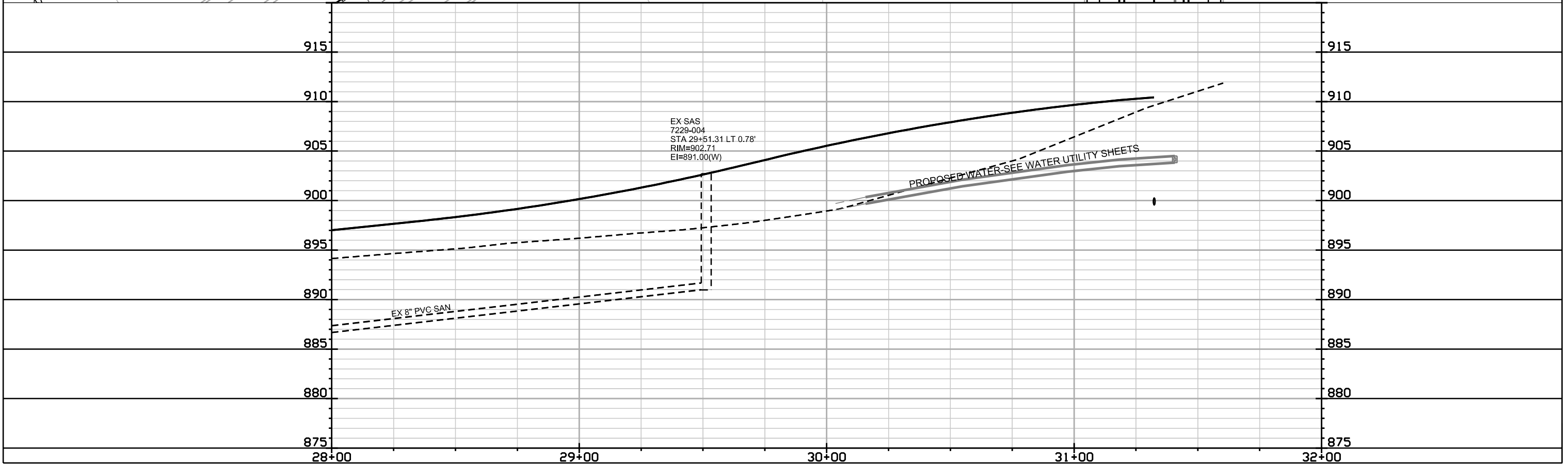
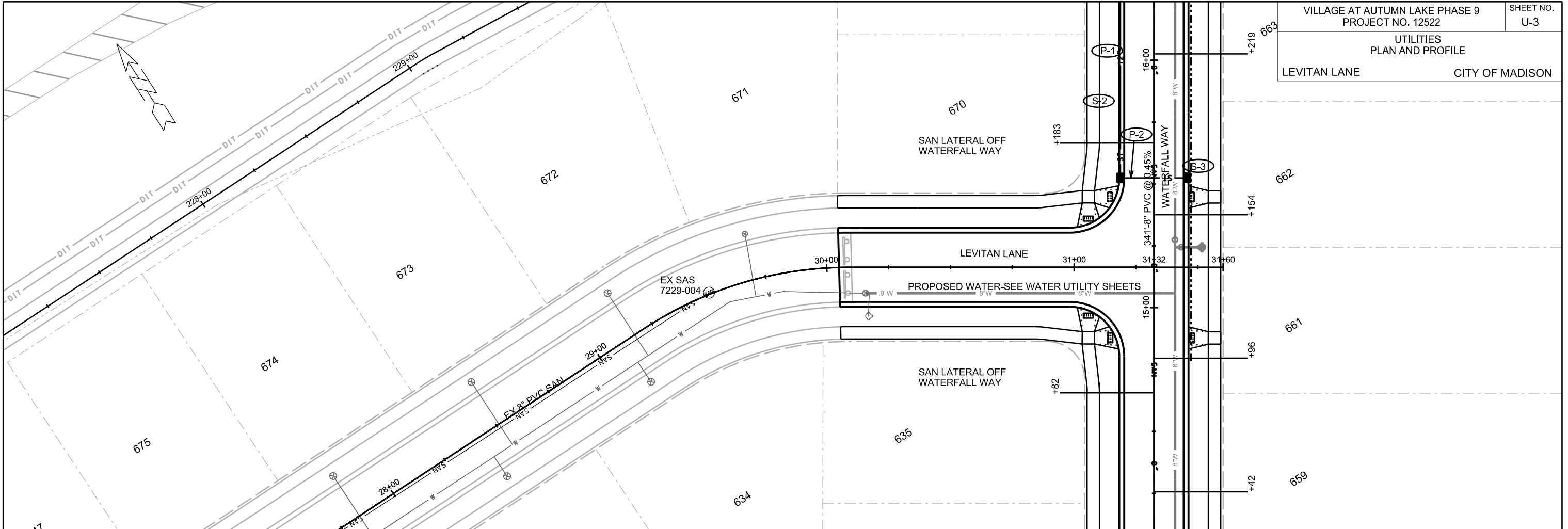

PLOT SCALE: \_\_\_\_\_

PLOT NAME: \_\_\_\_\_

REV. DATE: \_\_\_\_\_

ORIGINATOR: CITY OF MADISON, STREETS DIVISION

# SANITARY SEWER SCHEDULE

VILLAGE AT AUTUMN LAKE PHASE 9 PROJECT NO. 12522	SHEET NO. U-SAN
SANITARY SEWER SCHEDULE	
CITY OF MADISON	

## PROPOSED SANITARY STRUCTURES

SAS NO.	STATION	LOCATION (OFFSET)	TOP OF CASTING	E.I.	DEPTH	NOTES
<b>WATERFALL WAY</b>						
SAS#1	12+86.31	RT-2.35	907.29	896.79	10.50	-
SAS#2	13+83.78	RT-2.00	910.14	898.88	11.26	-
SAS#3	17+25.00	CL	910.83	900.52	10.31	-

## PROPOSED SANITARY PIPES

FROM (DNSTM)	TO (UPSTM)	DWNSTRM E.I.	UPSTRM E.I.	PLAN LGTH (FT)	SLOPE (%)	PIPE SIZE	PVC TYPE	NOTES
EX SAS	SAS#1	887.86	896.79	161	5.55%	8"	SDR-35	-
SAS#1	SAS#2	896.89	898.88	97	2.05%	8"	SDR-35	-
SAS#2	SAS#3	898.98	900.52	341	0.45%	8"	SDR-35	-

# STORM SEWER SCHEDULE

VILLAGE AT AUTUMN LAKE PHASE 9 PROJECT NO. 12522	SHEET NO. U-STM
STORM SEWER SCHEDULE	
CITY OF MADISON	

## PROPOSED STORM STRUCTURES

STRUC. NO.	STATION	LOCATION (OFFSET)	TYPE	TOP OF CASTING	E.I.	DEPTH	NOTES
------------	---------	-------------------	------	----------------	------	-------	-------

## WATERFALL WAY

S-1	17+81.54	LT-13.50	12" RCP AE	-	905.00	-	-
S-2	15+52.33	LT-13.50	H INLET	910.39	907.07	3.32	W/ R-3067-7004-VB
S-3	15+52.33	RT-13.50	H INLET	910.39	907.23	3.16	LP; W/ R-3067-7004-VB; (1)

## PROPOSED STORM PIPES

PIPE NO.	FROM (DNSTM)	TO (UPSTM)	DISCH. E.I.	INLET E.I.	PLAN (PAY) LGTH (FT)	PIPE LGTH (FT)	SLOPE (%)	PIPE SIZE	TYPE	NOTES
----------	--------------	------------	-------------	------------	----------------------	----------------	-----------	-----------	------	-------

P-1	S-1	S-2	905.00	907.07	229	228	0.91%	12"	RCP	-
P-2	S-2	S-3	907.07	907.23	27	25	0.64%	12"	RCP	-

**NOTE:** PLAN LENGTH (PAY LENGTH) IS FROM CENTER OF STRUCTURE TO CENTER OF STRUCTURE. PIPE LENGTH IS ACTUAL LENGTH OF PIPE FROM STRUCTURE WALL TO STRUCTURE WALL. SLOPE CALCULATED USING PIPE LENGTH.

## STANDARD NOTES:

- ABBREVIATIONS: AE = APRON ENDWALL; RCP = REINFORCED CONCRETE PIPE; HERCP = HORIZONTAL ELLIPTICAL REINFORCED CONCRETE PIPE; DNA = DOES NOT APPLY; SAS = SEWER ACCESS STRUCTURE; LP = LOW POINT INLET STRUCTURE; FP = FIELD POURED STRUCTURE; TR = TOP OF CONCRETE ROOF; NCM = NO CROWN MATCH FOR PIPES; UD = UNDERDRAIN

- APPROXIMATE DISCHARGE E.I. GIVEN, ADJUST E.I. AND PIPE SLOPE IN THE FIELD.

- TOP OF CASTING GRADE GIVEN IS THE TOP OF CURB FOR INLET STRUCTURES AND THE FLOWLINE OF THE CLOSED CASTING FOR SAS's.

- TOP OF CONCRETE ROOF (TR) IS 1.25' BELOW TOP OF CASTING UNLESS OTHERWISE NOTED.

- ALL REINFORCED CONCRETE PIPES TO BE CLASS III UNLESS OTHERWISE NOTED.

- SURVEYOR TO CONFIRM THAT ALL INLET STATION / OFFSETS LINE UP WITH PROPOSED CURB AND GUTTER.

- ALL STRUCTURES CALLED OUT AS FIELD POURED SHALL BE FIELD POURED. ALL OTHER STRUCTURES (NOT INDICATED AS FIELD POURED) SHALL BE SUBMITTED TO CITY ENGINEERING FOR APPROVAL IF PRECAST STRUCTURES ARE PREFERRED. CONTACT ELIA E. ACOSTA OF CITY ENGINEERING AT (608) 266-4096 FOR PRECAST APPROVALS, FAX SHOP DRAWINGS TO (608)264-9275, OR EMAIL SHOP DRAWINGS TO EACOSTA@CITYOFMADISON.COM.

## SPECIFIC NOTES

(1) INSTALL LOW POINT PVC DRAIN PER S.D.D 5.7.7A

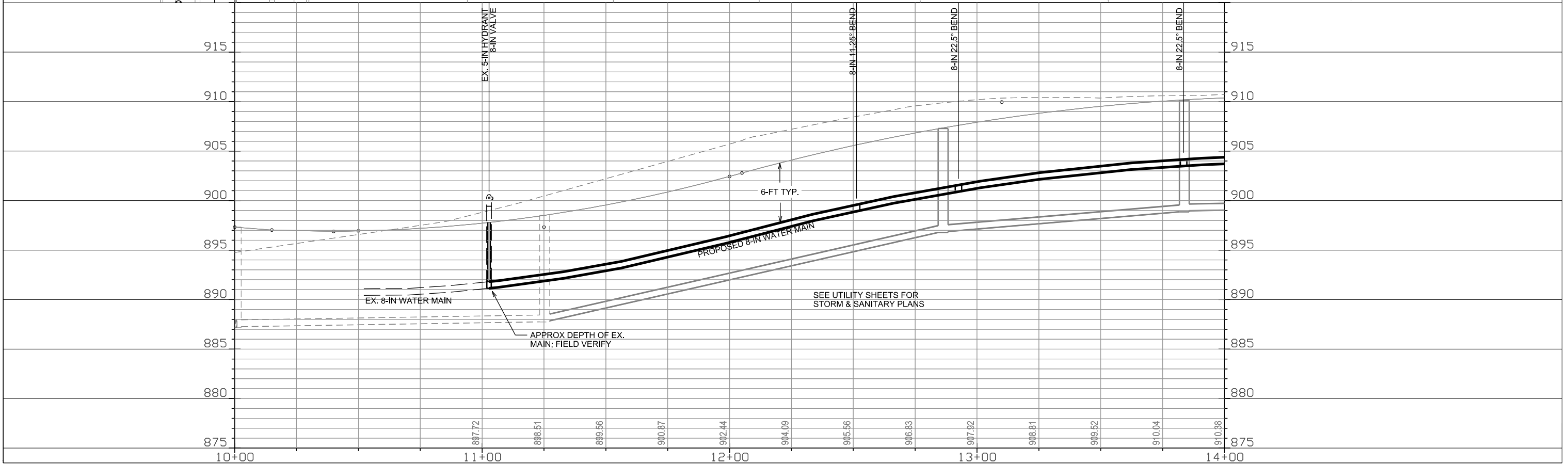
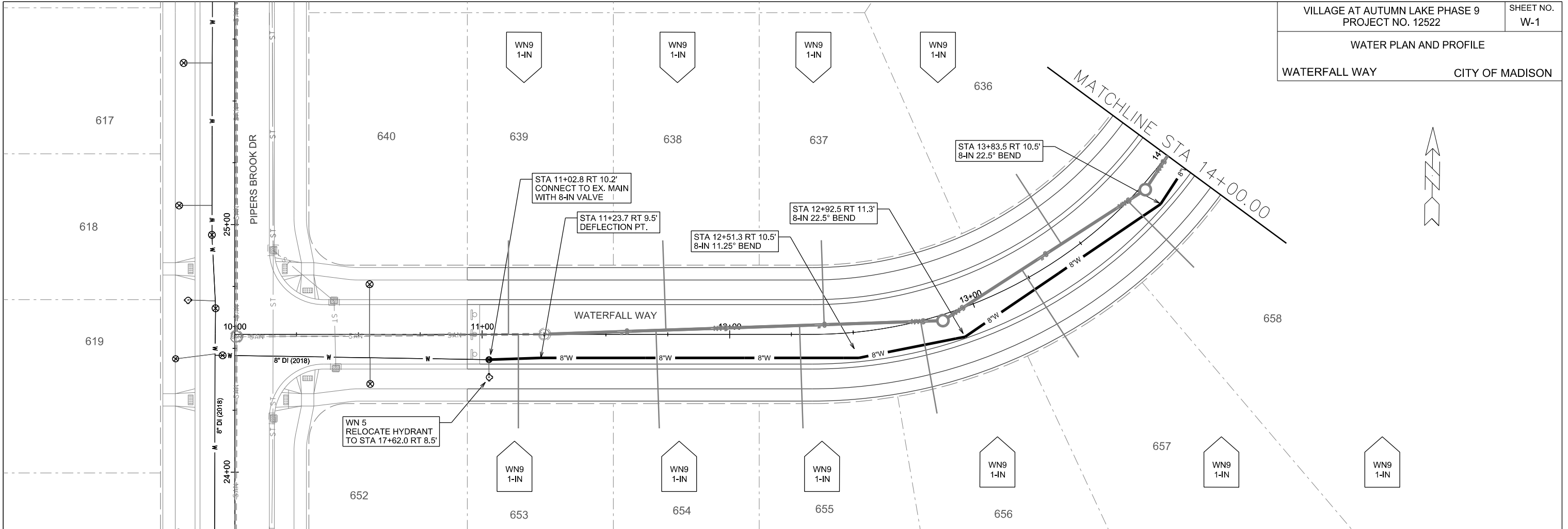

PLOT SCALE: \_\_\_\_\_

PLOT NAME: \_\_\_\_\_

REV. DATE: \_\_\_\_\_

ORIGINATOR: CITY OF MADISON, STREETS DIVISION



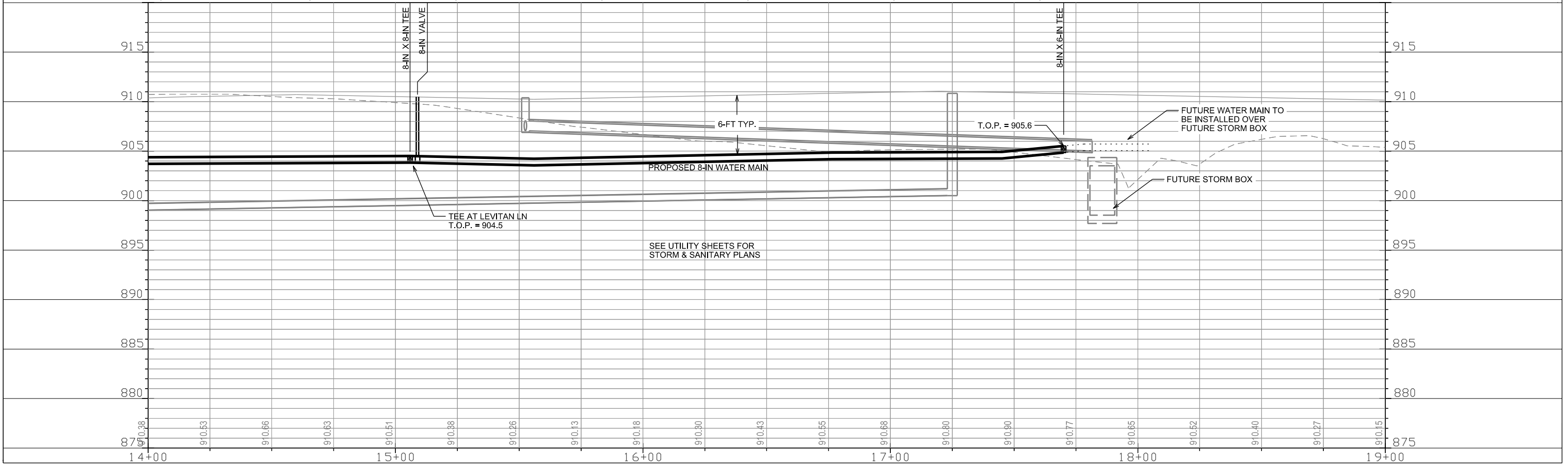
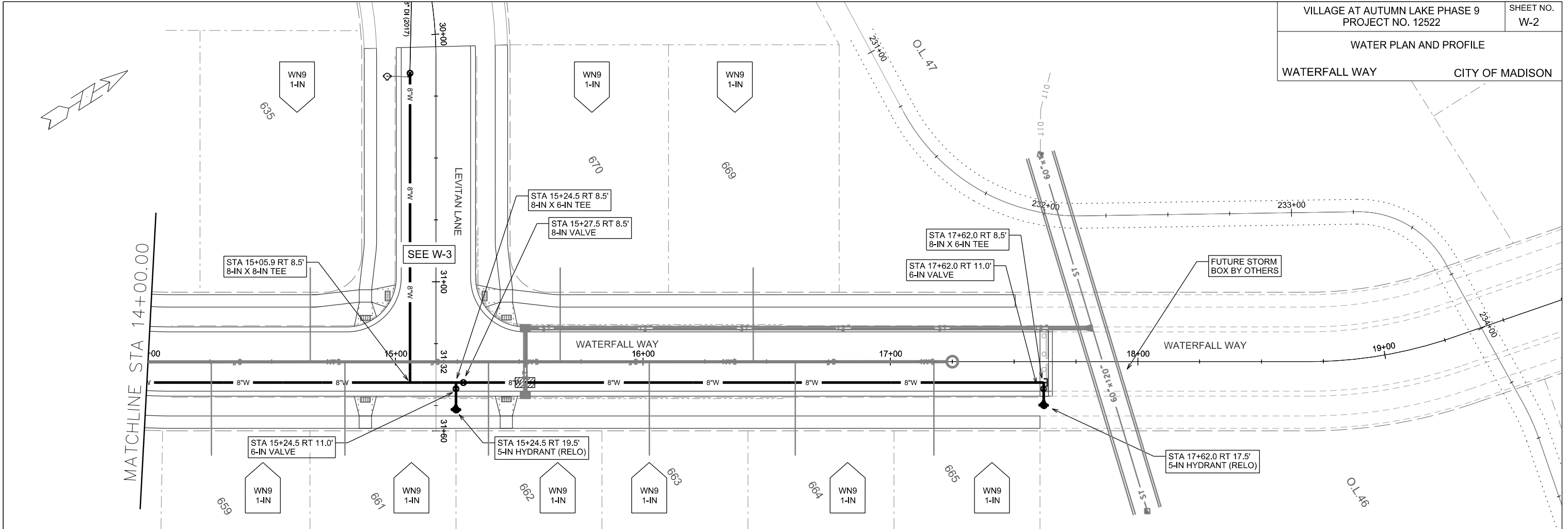

PLOT SCALE: \_\_\_\_\_

PLOT NAME: \_\_\_\_\_

REV. DATE: \_\_\_\_\_

ORIGINATOR: CITY OF MADISON, STREETS DIVISION

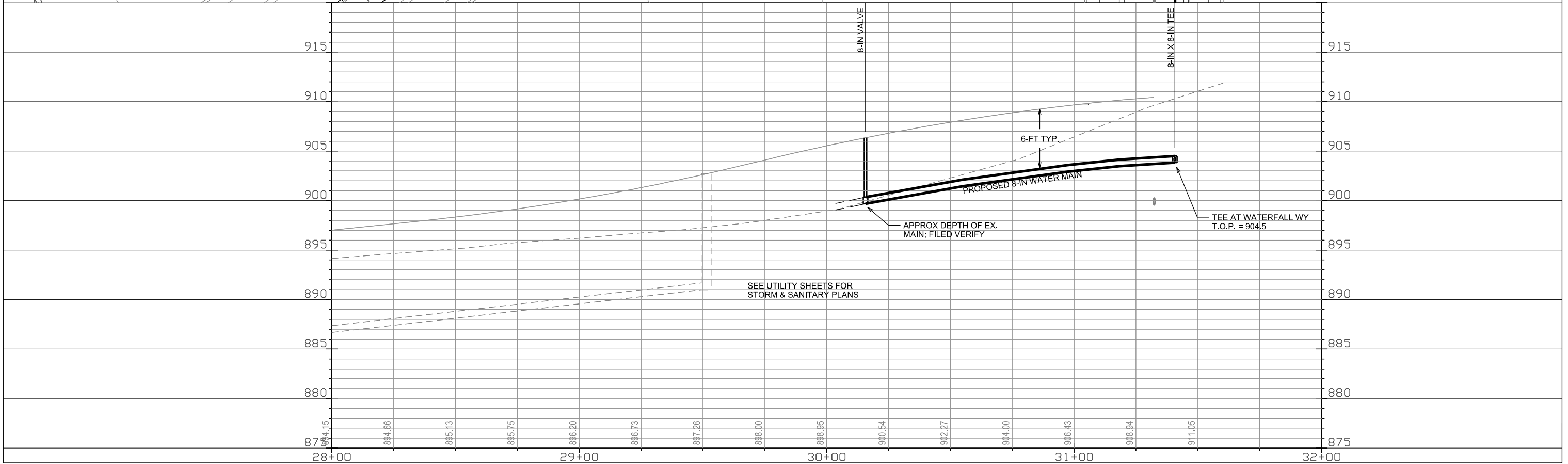
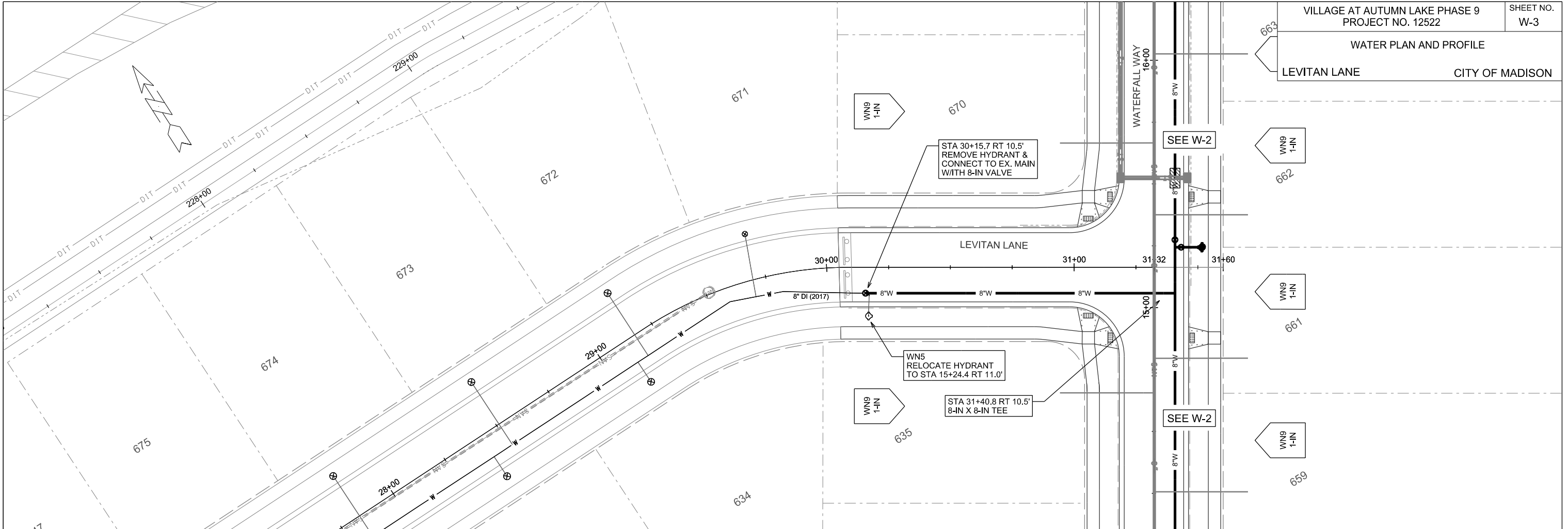

PLOT SCALE: \_\_\_\_\_

PLOT NAME: \_\_\_\_\_

REV. DATE: \_\_\_\_\_

ORIGINATOR: CITY OF MADISON, STREETS DIVISION

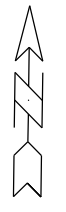

DISCLAIMER NOTE:  
THE WATER IMPACT PLAN IS PROVIDED FOR REFERENCE PURPOSES  
TO AIDE PLANNING CONNECTION POINT ISOLATION AND PREPARING  
NOTIFICATION LISTS DURING PLANNED OUTAGES. REQUEST ANY  
ALTERNATIVE CONNECTION METHODS IN WRITING, PER SPECS.

PLOT SCALE: \_\_\_\_\_

PLOT NAME: \_\_\_\_\_

REV. DATE: \_\_\_\_\_

ORIGINATOR: CITY OF MADISON, STREETS DIVISION

**CONSTRUCTION NOTES:**

1. CONSTRUCT NEW WATER MAIN 6.0' BELOW FINISHED GRADE, UNLESS OTHERWISE NOTED. INSULATE MAIN WITH POLYSTYRENE BOARD AT UTILITY CROSSINGS OR OTHER AREAS IDENTIFIED BY ENGINEER AS HAVING INADEQUATE COVER.
2. VERIFY SIZE OF EXISTING WATER SERVICES AND RECONNECT SERVICES AS INDICATED.
3. MINIMIZE DISRUPTION OF SERVICE TO EXISTING CUSTOMERS. NOTIFY PER CONTRACT REQUIREMENTS OF ANY PLANNED WATER OUTAGE.
4. THE EXISTING UTILITIES SHOWN ON THIS PLAN REPRESENT THE BEST INFORMATION AVAILABLE TO THE WATER UTILITY AT THE TIME OF PLAN PREPARATION. CONTRACTOR IS RESPONSIBLE FOR HAVING EACH UTILITY LOCATED PRIOR TO COMMENCING WORK.

- WN1 REPLACE THE EXISTING LEAD SERVICE WITH A NEW COPPER SERVICE.
- WN2 EXTEND AND RECONNECT THE EXISTING COPPER SERVICE TO THE NEW WATER MAIN.
- WN3 EXISTING SERVICE TO BE ABANDONED WHEN THE WATER MAIN IS CUT OFF.
- WN4 DISCONNECT FROM THE OLD WATER MAIN AND RECONNECT THE EXISTING COPPER WATER SERVICE LATERAL TO THE NEW WATER MAIN.
- WN5 RELOCATE THE EXISTING FIRE HYDRANT.
- WN6 ABANDON WATER VALVE ACCESS STRUCTURE.
- WN7 FURNISH AND INSTALL THE NEW TOP SECTION FOR THE WATER ACCESS STRUCTURE.
- WN8 ABANDON THE VALVE BOX.
- WN9 FURNISH THE DITCH, COMPACTION, AND ALL MATERIALS AND LABOR FOR THE INSTALLATION OF NEW SERVICE LATERAL.
- WN10 REMOVE AND SALVAGE EXISTING HYDRANT
- WN11 REPLACE THE EXISTING COPPER SERVICE WITH A COPPER SERVICE
- WN20+ SEE WATER IMPACT PLAN FOR CONNECTION POINT ISOLATION AND WATER SHUT-OFF NOTIFICATION INFORMATION.

**ESTIMATE OF MATERIALS SUPPLIED BY CONTRACTOR:**

*\* ESTIMATE OF MATERIALS IS FOR INFORMATION ONLY. ENGINEER DOES NOT GUARANTEE ACCURACY OF MATERIAL TAKE-OFF.*

- |                      |                                  |
|----------------------|----------------------------------|
| 20-FT - 6-IN PIPE    | 1 - 8-IN 11.25° BEND             |
| 790-FT - 8-IN PIPE   | 2 - 8-IN 22.5° BEND              |
| 1 - 6-IN VALVE & BOX | 1 - 8-IN MJ PLUG                 |
| 2 - 8-IN VALVE & BOX | 8-FT - 2-IN STYROFOAM INSULATION |
| 2 - 8-IN X 6-IN TEE  | 930-FT - POLY WRAP               |
| 1 - 8-IN X 8-IN TEE  | 1-IN TO 2-IN COPPER (AS REQ'D)   |

TO OBTAIN LOCATION OF PARTICIPANTS' UNDERGROUND FACILITIES BEFORE YOU DIG IN WISCONSIN

CALL DIGGERS HOTLINE  
TOLL FREE  
811 OR 1-800-242-8511  
FAX-A-LOCATE 1-800-338-3860  
TDD (FOR HEARING IMPAIRED) 1-800-542-2289

WIS. STATUTE 182.0175 (1974) REQUIRES MIN. OF 3 WORK DAYS NOTICE BEFORE YOU EXCAVATE.

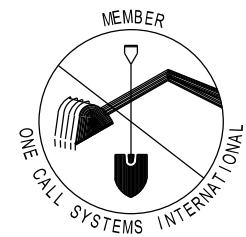

**MATERIALS SUPPLIED BY CITY:**

*\* ESTIMATE OF MATERIALS IS FOR INFORMATION ONLY. ENGINEER DOES NOT GUARANTEE ACCURACY OF MATERIAL TAKE-OFF.*

NONE

**ESTIMATE OF MATERIALS REUSED:**

*\* ESTIMATE OF MATERIALS IS FOR INFORMATION ONLY. ENGINEER DOES NOT GUARANTEE ACCURACY OF MATERIAL TAKE-OFF.*

2 - 5-IN HYDRANT

**DISCLAIMER NOTE:**  
UTILITY LOCATIONS SHOWN ARE APPROXIMATE ONLY. IT SHALL BE THE CONTRACTOR'S RESPONSIBILITY TO DETERMINE THE EXACT HORIZONTAL AND VERTICAL LOCATION OF ALL EXISTING UNDERGROUND AND OVERHEAD UTILITIES PRIOR TO COMMENCING WORK.

**PART VII - WATER MAINS AND SERVICE LATERALS**

**DETAIL DRAWING NO. 7.04**

REVISED: 12/2017

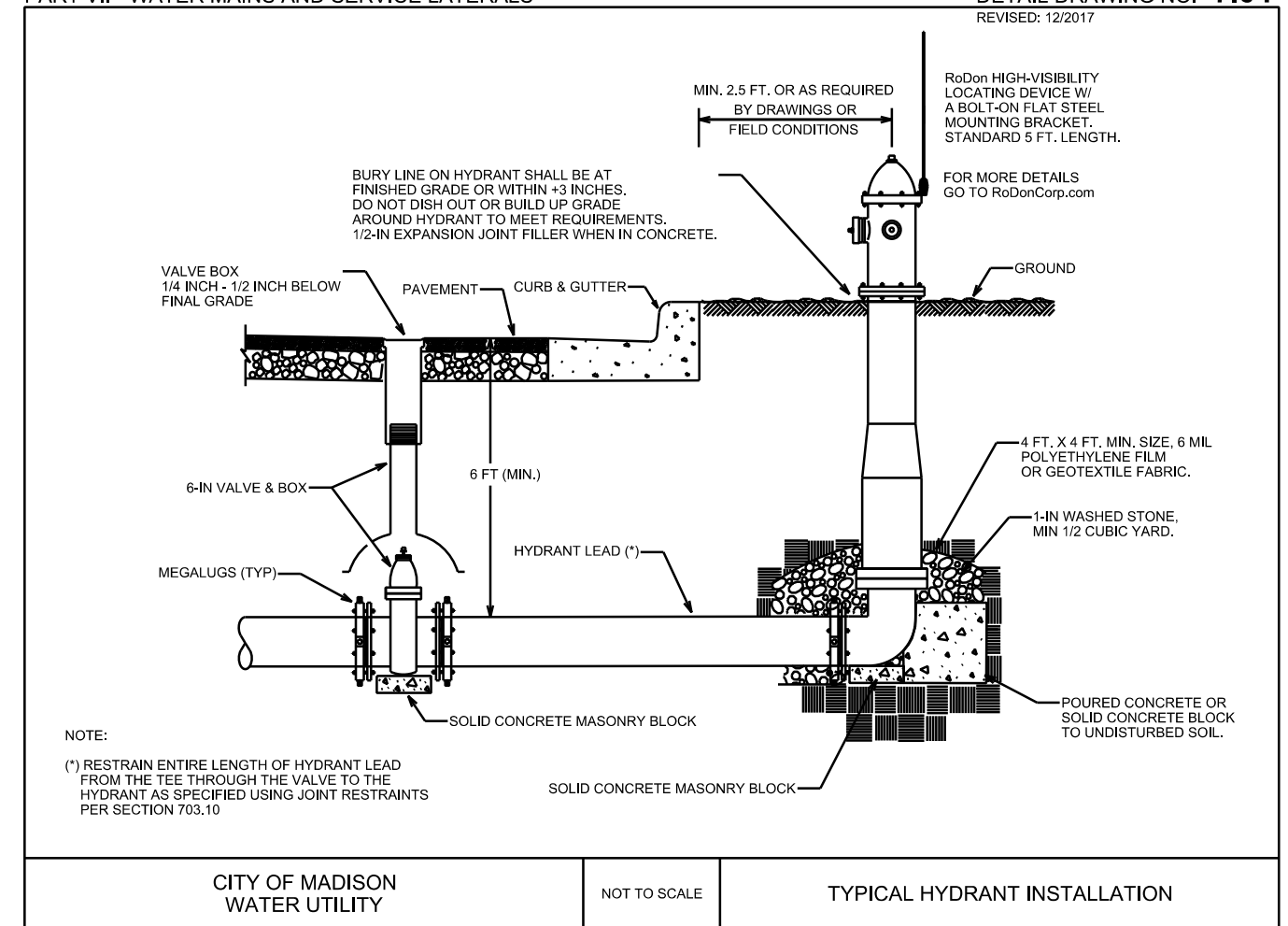

CITY OF MADISON  
WATER UTILITY

NOT TO SCALE

TYPICAL HYDRANT INSTALLATION

City of Madison Standard Specifications for Public Works Construction