

REVISION 6/19/20 AJZ  
- New Sheet C4.1A

PUBLIC IMPROVEMENT PROJECT APPROVED

MAY 21, 2019

BY THE COMMON COUNCIL  
OF MADISON, WISCONSIN

PUBLIC IMPROVEMENT DESIGN  
APPROVED BY:

*[Signature]* 3/17/20  
City Engineer Date

STREET  
DESIGNED BY:

*[Signature]*  
ANDREW J. ZWIEG  
E-41753  
FITCHBURG, WI  
3-9-20  
PROFESSIONAL ENGINEER

STORM SEWER  
DESIGNED BY:

JANET SCHMIDT  
E-3468  
MADISON, WI  
3-23-20  
PROFESSIONAL ENGINEER

PAVEMENT MARKING  
DESIGNED BY:

*[Signature]*  
MARK S. WINTER  
E-39453  
MADISON, WI  
3/17/20  
PROFESSIONAL ENGINEER

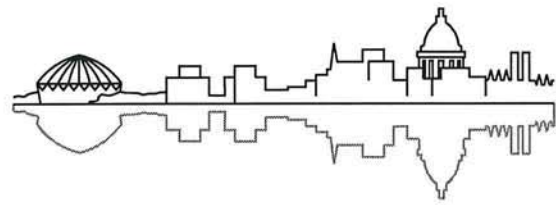

Madison, Wisconsin

# CITY OF MADISON

## CITY ENGINEERING DIVISION DEPARTMENT OF PUBLIC WORKS

### PLAN OF PROPOSED IMPROVEMENT

#### 4202 HOEPKER ROAD (MANUFACTURERS DRIVE EXTENSION TO ANDERSON ROAD, IMPROVEMENTS TO HOEPKER ROAD AND ANDERSON ROAD)

CITY PROJECT NO. 12591  
CONTRACT NO. 8384

INDEX OF SHEETS

SHEET NO.	TITLE
1	NOTES & TYPICAL SECTIONS
D1-D4	COMMERCE PARK DR REMOVAL
D5	4195 ANDERSON ROAD IMPROVEMENTS
D6, C1.4, C2.4, C3.9, C1.5	STREET PLAN & PROFILE
P1-P10	SEWER PLAN & PROFILE
U1-U6	SEWER SCHEDULES ← <b>New Sheet C4.1A Storm Connection to Public System</b>
U-STM	PAVEMENT MARKING PLANS
M1-M4	CROSS SECTIONS MANUFACTURERS DRIVE
X1-X12	CROSS SECTIONS ANDERSON ROAD
X13-X14	CROSS SECTIONS HOEPKER ROAD/USH 51
X15-X20	CROSS SECTIONS HOEPKER ROAD/MANUFACTURERS DRIVE
X21-X25	CROSS SECTIONS HOEPKER ROAD SIDEWALK
X26-X34	MAINTANENCE MAP (CITY USE ONLY)
MM-1	

PROJECT  
LOCATION

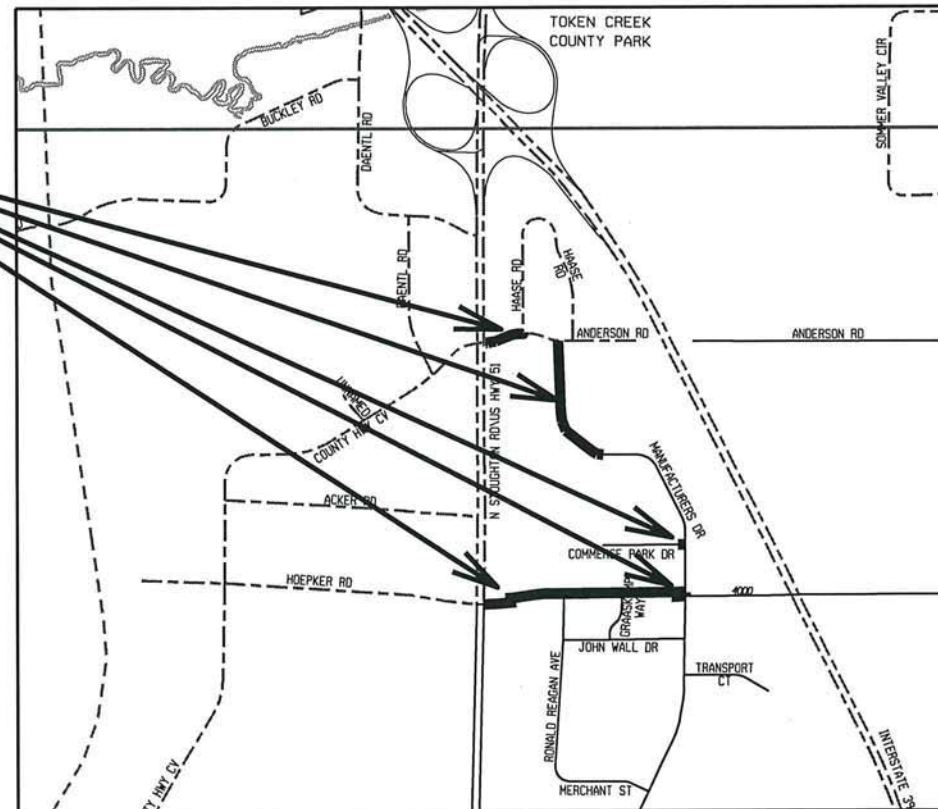

CONVENTIONAL SIGNS

FIELD VERIFY ALL UTILITY LOCATIONS

GAS	G
STORM SEWER	ST
SANITARY SEWER	SAN
WATER	W
OVERHEAD ELECTRIC	OH
FIBER OPTIC	FO
POWER POLE	⊕

NOTES:

ALL GUTTERS SHALL DRAIN WITH A MINIMUM GRADE OF 0.50% TOWARD STORM SEWER INLETS.

SIDEWALK RAMPS AND CURB THRU SIDEWALK RAMPS SHALL HAVE A MAXIMUM SLOPE OF 1" PER 12". SIDEWALK AND CURB RAMPS SHALL BE CONSTRUCTED WITH A SIDE SLOPE OF 2.00%. SIDEWALK SHALL HAVE A MINIMUM LONGITUDINAL SLOPE OF 0.50% AND A MAXIMUM LONGITUDINAL SLOPE OF 5.00%

PLOT SCALE: \_\_\_\_\_

PLOT NAME: \_\_\_\_\_

REV. DATE: \_\_\_\_\_

ORIGINATOR: CITY OF MADISON, STREETS DIVISION

CONTRACTOR/DEVELOPER SHALL WORK WITH CITY TRAFFIC ENGINEERING TO SUBMIT A TRAFFIC CONTROL PLAN AT LEAST 10 WORKING DAYS PRIOR TO THE START OF WORK. WORK WITHIN THE RIGHT-OF-WAY SHALL NOT BEGIN UNTIL THE TRAFFIC CONTROL PLAN IS APPROVED.

ANY PAVEMENT MARKINGS THAT ARE REMOVED OR DAMAGED SHALL BE REPLACED BY THE DEVELOPER/CONTRACTOR AS DIRECTED BY CITY TRAFFIC ENGINEERING.

THE LOCATION AND INFORMATION FOR PROPOSED NEW TREES, IN THE PUBLIC RIGHT OF WAY OR ON PUBLIC LANDS ARE APPROXIMATE AND ARE SHOWN FOR REFERENCE ONLY.

THE CONTRACTOR SHALL CONTACT BRAD HOFMANN OF CITY FORESTRY AT LEAST ONE WEEK PRIOR TO PLANTING TO SCHEDULE MARKING THE PLANTING SITE, INSPECTING THE NURSERY STOCK, AND REVIEWING PLANTING SPECIFICATIONS WITH THE LANDSCAPER. CONTACT BRAD AT BHOFMANN@CITYOFMADISON.COM OR (608) 266-4908.

NO TREES IN THE RIGHT OF WAY OR ON PUBLIC LANDS SHALL BE TRIMMED, PRUNED, REMOVED OR ADVERSELY AFFECTED IN ANY WAY UNTIL THE DEVELOPER HAS RECEIVED WRITTEN PERMISSION FROM THE CITY ENGINEER OR CITY FORESTER. SAID WRITTEN PERMISSION SHALL INCLUDE LANGUAGE INDICATING THAT SECTION 10.101 OF THE MADISON GENERAL ORDINANCES AND ADMINISTRATIVE PROCEDURE MEMORANDUM NO. 6-2, REFERING TO NOTIFICATION OF PROPERTY OCCUPANTS AND/OR OWNERS, HAS BEEN COMPLIED WITH.

ALL PAVEMENT WITHIN THE MANUFACTURERS DRIVE, ANDERSON ROAD, AND HOEPKER ROAD RIGHT-OF-WAY SHALL CONSIST OF:  
2" BITUMINOUS UPPER LAYER, 4 MT 58-28 S  
3.5" BITUMINOUS LOWER LAYER 3 MT 58-28 S

ALL GUTTERS SHALL DRAIN WITH A MINIMUM GRADES OF 0.5% TOWARD STORM SEWER INLETS.

THE CROSS SLOPE OF SIDEWALKS AND BARRIER FREE SIDEWALK CURB RAMPS SHALL BE 1.5%. THE LONGITUDINAL GRADE OF BARRIER FREE SIDEWALK CURB RAMPS SHALL NOT EXCEED 8.33%. ALL SIDEWALK RAMPS SHALL BE CONSTRUCTED ACCORDING TO S.D.D. 3.03. AT ALL OTHER LOCATIONS THE LONGITUDINAL GRADE OF SIDEWALKS SHALL NOT EXCEED 5.0 % OR THE ADJACENT STREET GRADE WHICHEVER IS GREATER NOR BE LESS THAN 0.5% AND SHALL DRAIN TOWARD STORM SEWER INLETS. SIDE SLOPES WITHIN TEN FEET OF A PUBLIC SIDEWALK SHALL NOT EXCEED 4.00:1. ALL SIDEWALK AND SIDEWALK RAMP ELEVATIONS AND GRADES SHALL BE FIELD VERIFIED AND SET TO COMPLY WITH THE CITY OF MADISON STANDARD SPECIFICATIONS AND THE A.D.A. GUIDELINES.

OBTAIN A PRINT OUT OF THE ALIGNMENT FROM THE CITY ENGINEER PRIOR TO STAKING THIS PROJECT.

CURB STATION AND OFFSETS SHALL BE TO THE FACE OF CURB UNLESS OTHERWISE INDICATED. CURB ELEVATIONS SHALL BE TO THE TOP OF CURB (OR EXTENDED TOP OF CURB FOR DRIVEWAYS OR RAMPS) UNLESS OTHERWISE INDICATED.

POWER POLES AND OTHER OBSTRUCTIONS SHALL BE MOVED TO PROVIDE 2 FEET MINIMUM OF CLEAR DISTANCE FROM ANY FACE OF CURB OR EDGE OF SIDEWALK.

ANY INFORMATION SHOWN ON THIS PLAN, WHICH IS NOT PART OF THIS PROJECT, IS PRELIMINARY AND NOT FOR CONSTRUCTION.

THERE MAY BE EXISTING UTILITIES OR OTHER FEATURES WHICH ARE EITHER NOT SHOWN OR SHOWN INCORRECTLY ON THIS PLAN. IT IS THE RESPONSIBILITY OF THE DEVELOPER TO LOCATE AND IDENTIFY ALL UTILITIES AND TOPOGRAPHY WHICH MAY AFFECT THE CONSTRUCTION OF THESE IMPROVEMENTS.

ALL PERMANENT SIGNING AND POSTING WILL BE DETERMINED AND PROVIDED BY THE TRAFFIC ENGINEERING DIVISION, FOLLOWING CONSTRUCTION OF THESE IMPROVEMENTS.

THE DEVELOPER SHALL PROVIDE, INSTALL AND MAINTAIN ALL STREET END BARRICADES, SIGNING AND TRAFFIC CONTROL, AS REQUIRED BY THE CITY TRAFFIC ENGINEER.

PAVEMENT SAWCUTS SHALL BE AS DIRECTED BY THE CITY CONSTRUCTION ENGINEER. SAWCUTS SHOWN ON THE PLAN ARE APPROXIMATE.

DAMAGE TO ANY EXISTING CURB, PAVEMENT, SIDEWALK, ETC. THAT IS TO REMAIN SHALL BE REPAIRED BY THE DEVELOPER/CONTRACTOR AS DIRECTED BY THE ENGINEER.

PLOT SCALE: \_\_\_\_\_

PLOT NAME: \_\_\_\_\_

REV. DATE: \_\_\_\_\_

ORIGINATOR: CITY OF MADISON, STREETS DIVISION

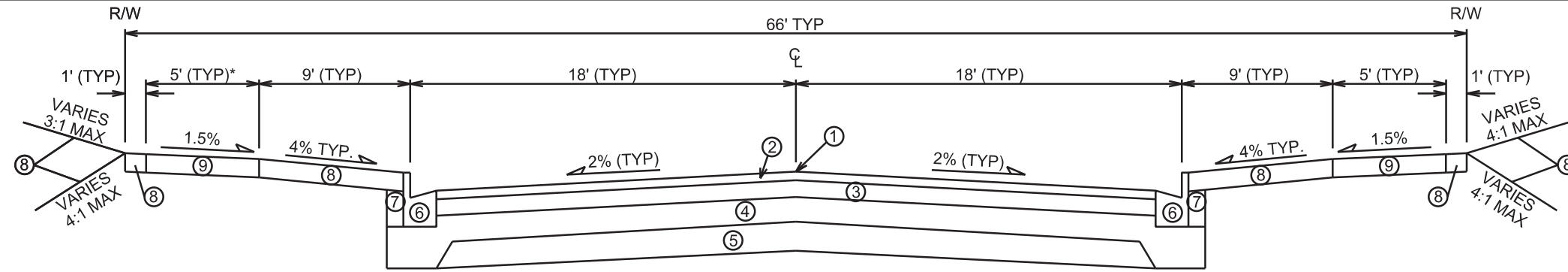

TYPICAL FINISHED SECTION  
MANUFACTURERS DRIVE  
STA 110+80.11 TO STA 118+35.00

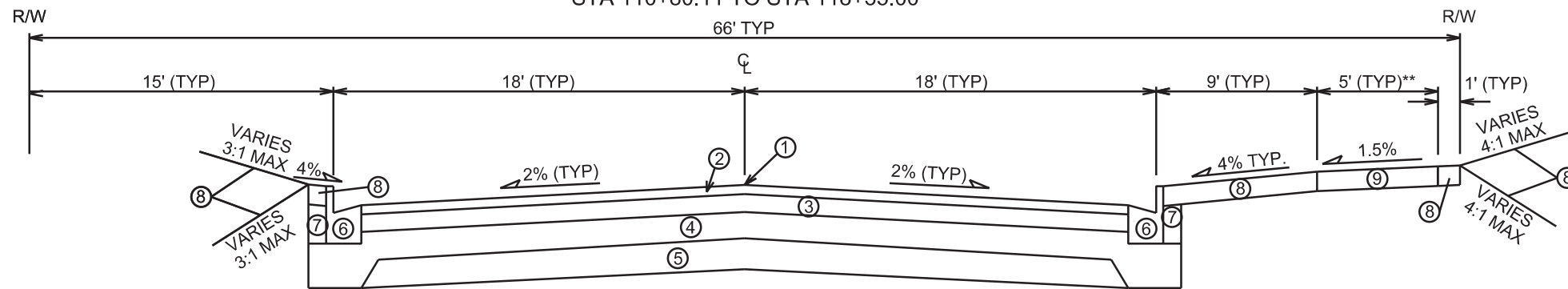

TYPICAL FINISHED SECTION  
MANUFACTURERS DRIVE  
STA 118+35.00 TO STA 118+75.00

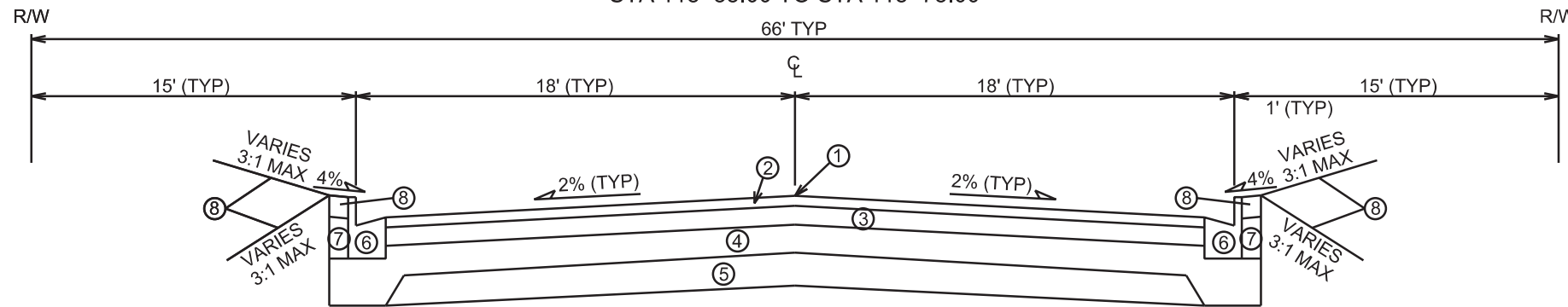

TYPICAL FINISHED SECTION  
MANUFACTURERS DRIVE  
STA 118+75.00 TO STA 123+75.00

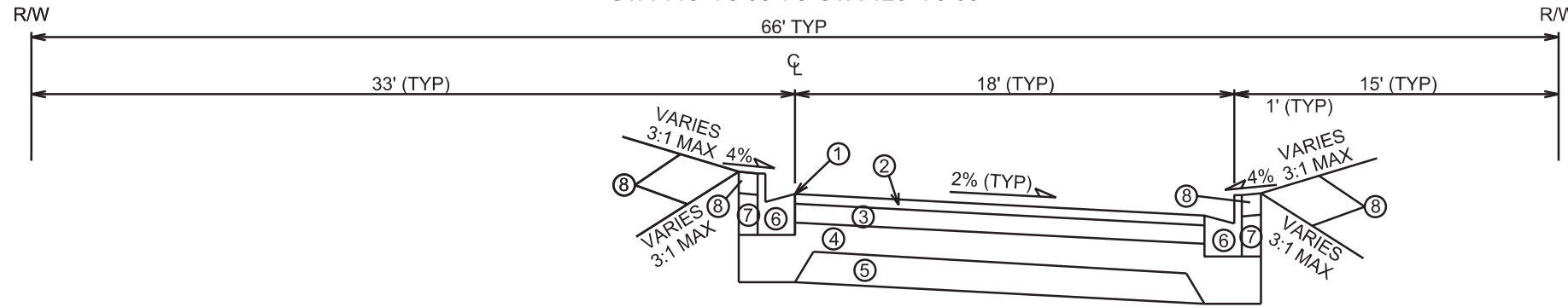

TYPICAL FINISHED SECTION  
MANUFACTURERS DRIVE  
STA 123+75.00 TO STA 125+54.82

- ① POINT REFERRED TO ON PROFILE
- ② 2" BITUMINOUS UPPER LAYER, 4 MT 58-28 S
- ③ 3 1/2" BITUMINOUS LOWER LAYER, 3 MT 58-28 S
- ④ 6" GRADATION 2 CRUSHED STONE
- ⑤ 6" GRADATION 1 CRUSHED STONE
- ⑥ TYPE 'A' CONCRETE CURB & GUTTER
- ⑦ FILL, INCIDENTAL
- ⑧ 6" TOPSOIL, TERRACE SEED AND EROSION MAT
- ⑨ 5" CONCRETE SIDEWALK

NOTE:  
- SEE PLAN/PROFILE SHEETS FOR TOP OF CURB ELEVATIONS.  
- TYPICAL SECTION NOT TO SCALE.

\*END SIDEWALK CONSTRUCTION  
STA 118+35 LT

\*\*END SIDEWALK CONSTRUCTION  
STA 118+75 RT

PLOT SCALE: \_\_\_\_\_  
PLOT NAME: \_\_\_\_\_  
REV. DATE: \_\_\_\_\_  
ORIGINATOR: CITY OF MADISON, STREETS DIVISION

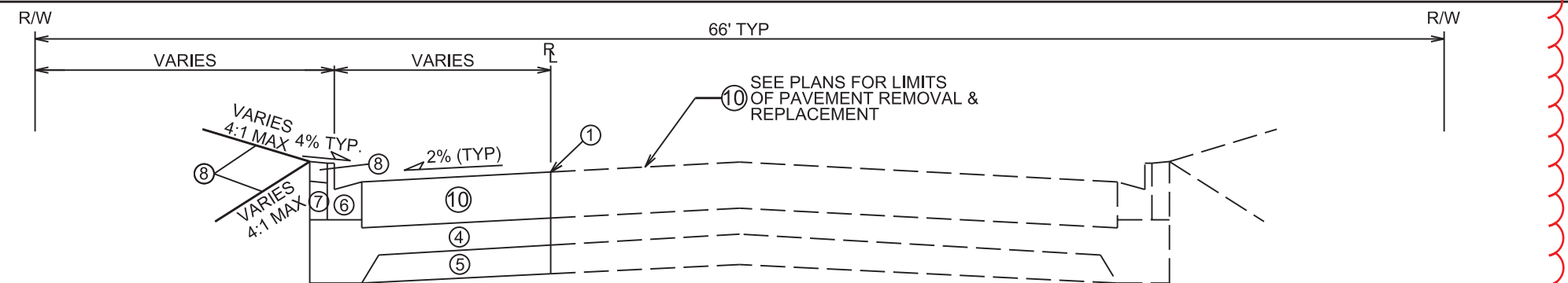

TYPICAL FINISHED SECTION  
ANDERSON ROAD/USH 51  
STA 30+38.02 TO STA 32+75.05

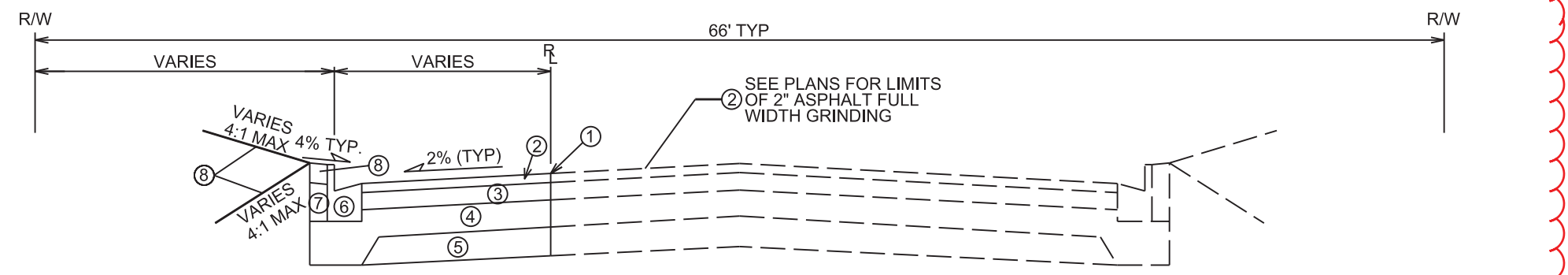

TYPICAL FINISHED SECTION  
ANDERSON ROAD/USH 51  
STA 32+75.05 TO STA 34+34.37

- ① POINT REFERRED TO ON PROFILE
- ② 2" BITUMINOUS UPPER LAYER, 4 MT 58-28 S
- ③ 3 1/2" BITUMINOUS LOWER LAYER, 3 MT 58-28 S
- ④ 6" GRADATION 2 CRUSHED STONE
- ⑤ 6" GRADATION 1 CRUSHED STONE
- ⑥ TYPE 'A' CONCRETE CURB & GUTTER
- ⑦ FILL, INCIDENTAL
- ⑧ 6" TOPSOIL, TERRACE SEED AND EROSION MAT
- ⑨ 5" CONCRETE SIDEWALK
- ⑩ 11" CONCRETE PAVEMENT

NOTE:  
- SEE PLAN/PROFILE SHEETS FOR  
TOP OF CURB ELEVATIONS.  
- TYPICAL SECTION NOT TO SCALE.

REVISION 5/29/20 AJZ  
- Split Anderson Rd Typical for  
Section of Concrete Pavement  
and Asphalt Pavement  
- Remove X's

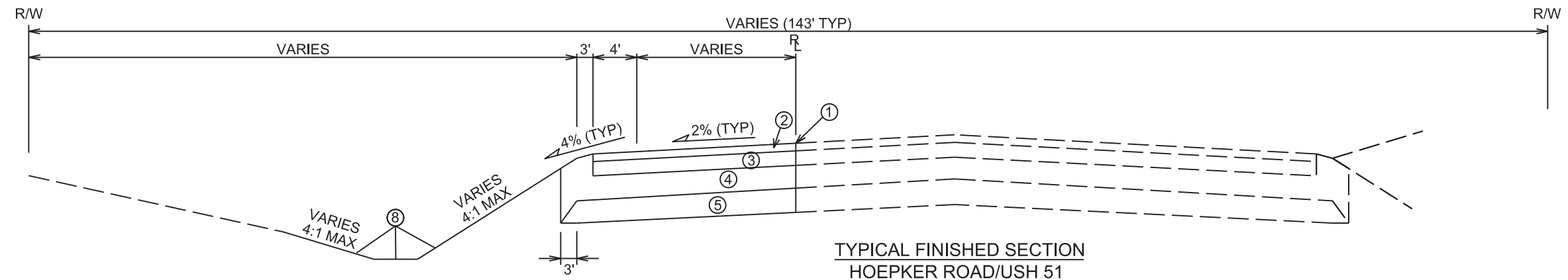

TYPICAL FINISHED SECTION  
HOEPKER ROAD/USH 51  
STA 20+20.82 TO STA 23+80.91

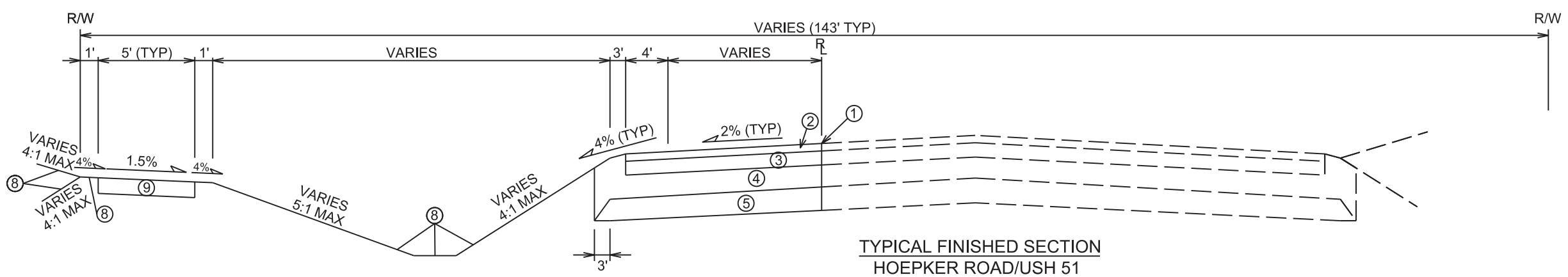

TYPICAL FINISHED SECTION  
HOEPKER ROAD/USH 51  
STA 23+80.91 TO STA 25+14.62

PLOT SCALE: \_\_\_\_\_  
PLOT NAME: \_\_\_\_\_  
REV. DATE: \_\_\_\_\_  
ORIGINATOR: CITY OF MADISON, STREETS DIVISION

TYPICAL SECTIONS  
HOEPKER ROAD/MANUFACTURERS ROAD  
HOEPKER SIDEWALK CITY OF MADISON

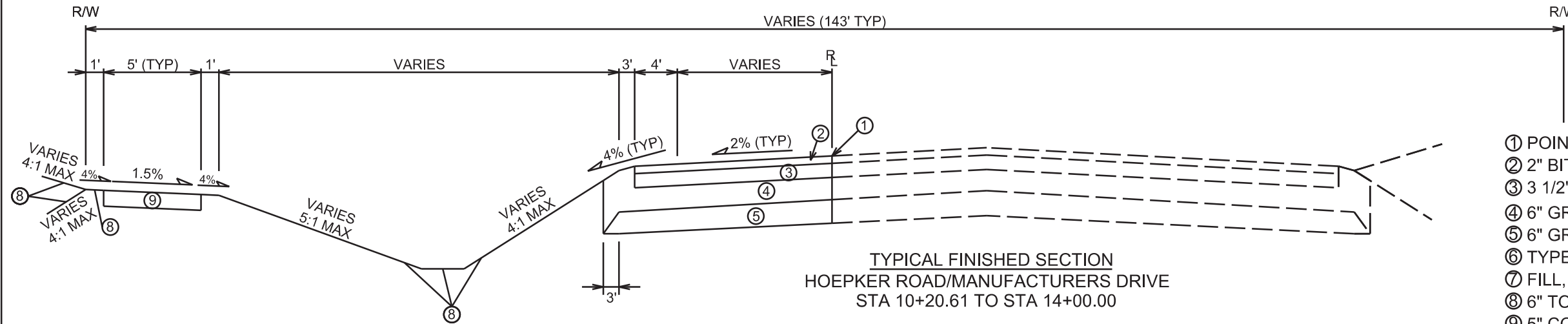

TYPICAL FINISHED SECTION  
HOEPKER ROAD/MANUFACTURERS DRIVE  
STA 10+20.61 TO STA 14+00.00

- ① POINT REFERRED TO ON PROFILE
- ② 2" BITUMINOUS UPPER LAYER, 4 MT 58-28 S
- ③ 3 1/2" BITUMINOUS LOWER LAYER, 3 MT 58-28 S
- ④ 6" GRADATION 2 CRUSHED STONE
- ⑤ 6" GRADATION 1 CRUSHED STONE
- ⑥ TYPE 'A' CONCRETE CURB & GUTTER
- ⑦ FILL, INCIDENTAL
- ⑧ 6" TOPSOIL, TERRACE SEED AND EROSION MAT
- ⑨ 5" CONCRETE SIDEWALK

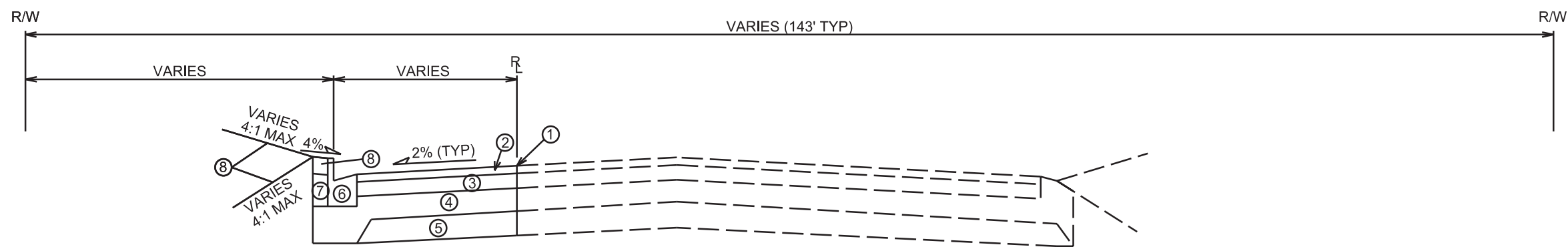

TYPICAL FINISHED SECTION  
HOEPKER ROAD/MANUFACTURERS DRIVE  
STA 14+00.00 TO STA 15+07.48

NOTE:  
- SEE PLAN/PROFILE SHEETS FOR  
TOP OF CURB ELEVATIONS.  
- TYPICAL SECTION NOT TO SCALE.

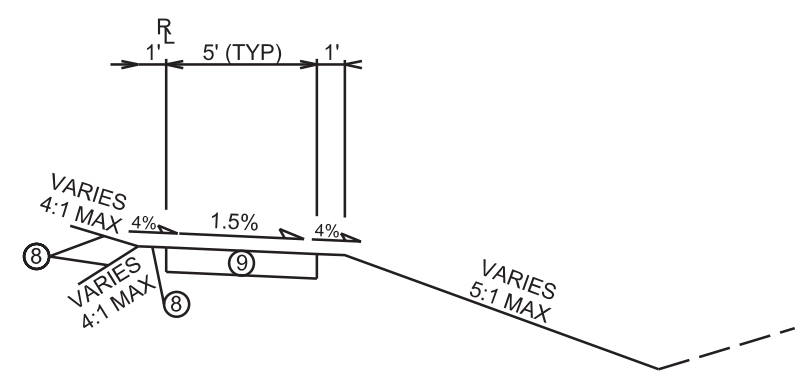

TYPICAL FINISHED SECTION  
HOEPKER ROAD SIDEWALK  
STA 204+00.00 TO STA 220+42.07

PLOT SCALE: \_\_\_\_\_  
PLOT NAME: \_\_\_\_\_  
REV. DATE: \_\_\_\_\_  
ORIGINATOR: CITY OF MADISON, STREETS DIVISION

PLAN  
VACATED COMMERCE PARK DRIVE  
MANUFACTURERS DRIVE CITY OF MADISON

- ① POINT REFERRED TO ON PROFILE
- ② 2" BITUMINOUS UPPER LAYER, 4 MT 58-28 S (BY CITY OF MADISON)
- ③ 3 1/2" BITUMINOUS LOWER LAYER, 3 MT 58-28 S
- ④ 6" GRADATION 2 CRUSHED STONE
- ⑤ 6" GRADATION 1 CRUSHED STONE
- ⑥ TYPE 'A' CONCRETE CURB & GUTTER
- ⑦ FILL, INCIDENTAL
- ⑧ 6" TOPSOIL, TERRACE SEED AND EROSION MAT
- ⑨ 5" CONCRETE SIDEWALK

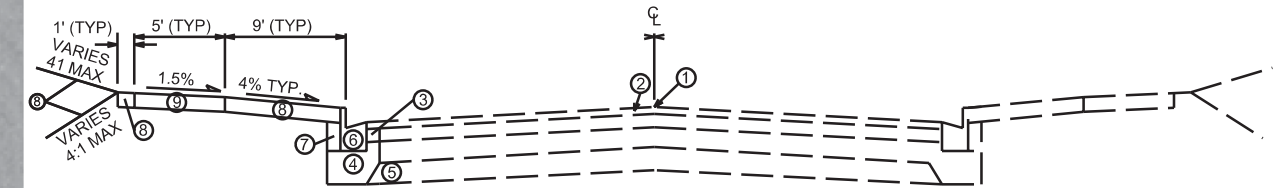

TYPICAL FINISHED SECTION  
MANUFACTURERS DRIVE/COMMERCE PARK DRIVE

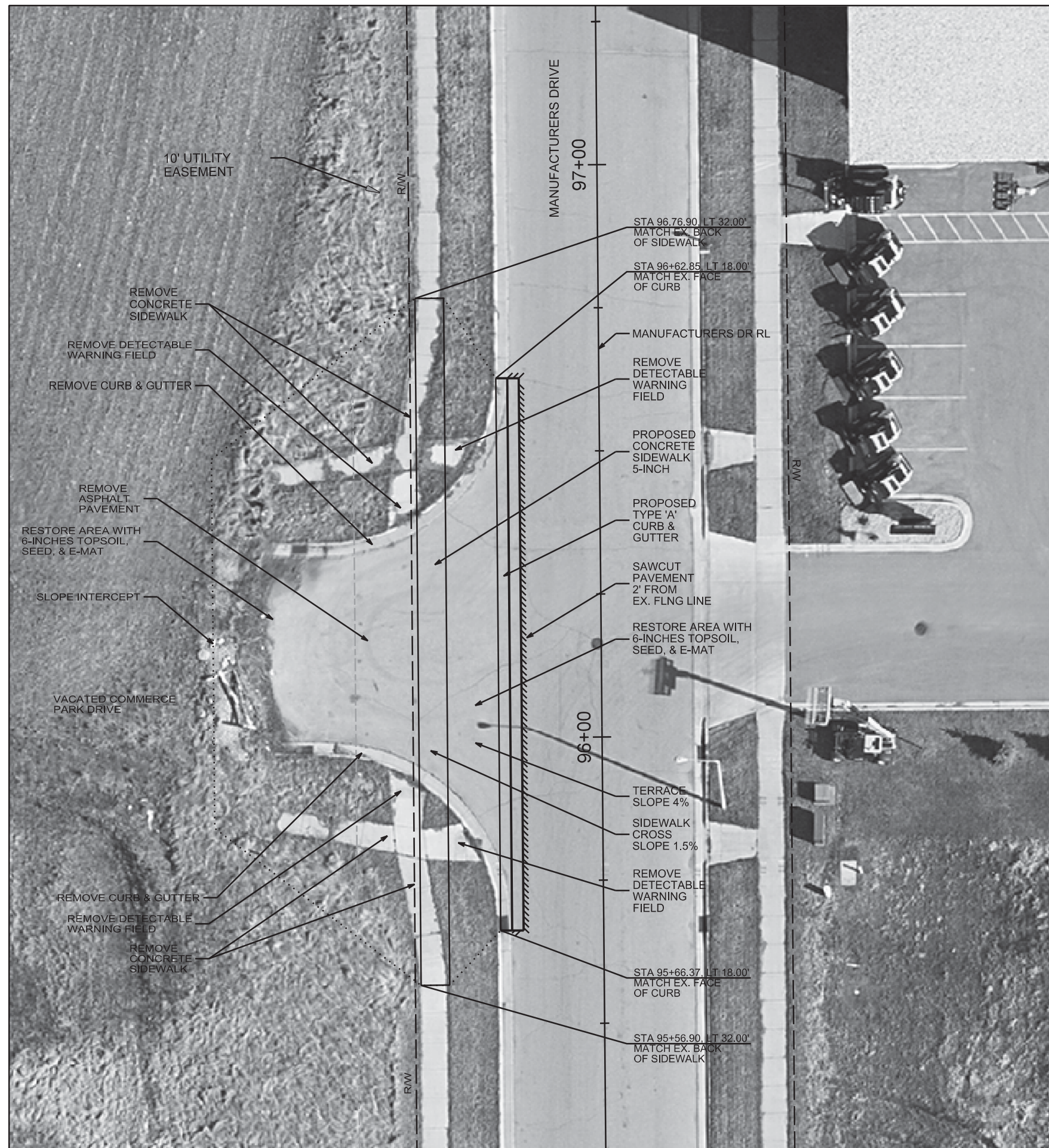

PLOT SCALE: \_\_\_\_\_

PLOT NAME: \_\_\_\_\_

REV. DATE: \_\_\_\_\_

ORIGINATOR: CITY OF MADISON, STREETS DIVISION

**REVISION 5/29/20 AJZ**

- Added Full Width Grinding on Anderson
- Added Note Temporary Easement Acquired
- Remove X's

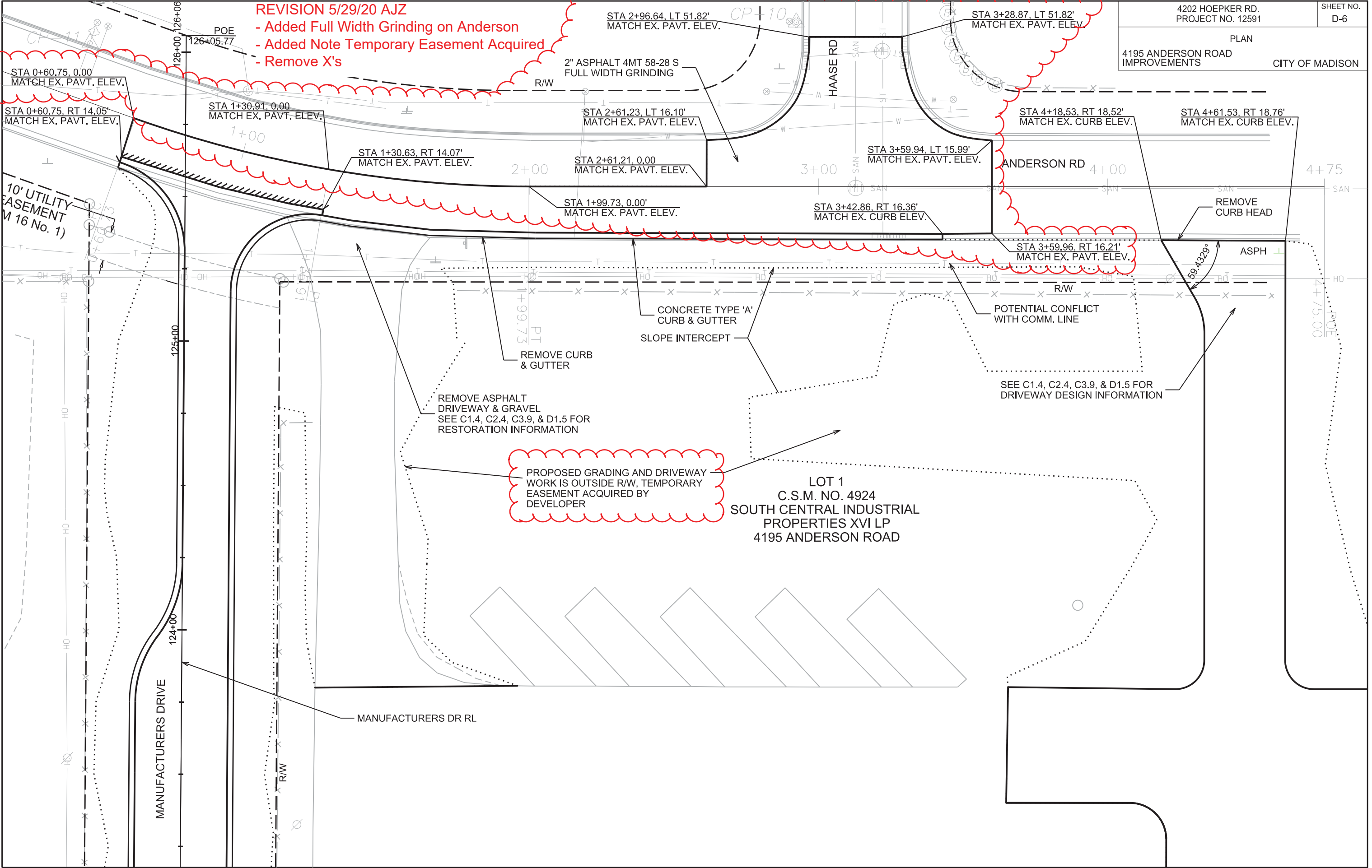

PROPOSED GRADING AND DRIVEWAY  
WORK IS OUTSIDE R/W, TEMPORARY  
EASEMENT ACQUIRED BY  
DEVELOPER

LOT 1  
C.S.M. NO. 4924  
SOUTH CENTRAL INDUSTRIAL  
PROPERTIES XVI LP  
4195 ANDERSON ROAD

PLOT SCALE:

PLOT NAME:

REV. DATE:

ORIGINATOR: CITY OF MADISON, STREETS DIVISION

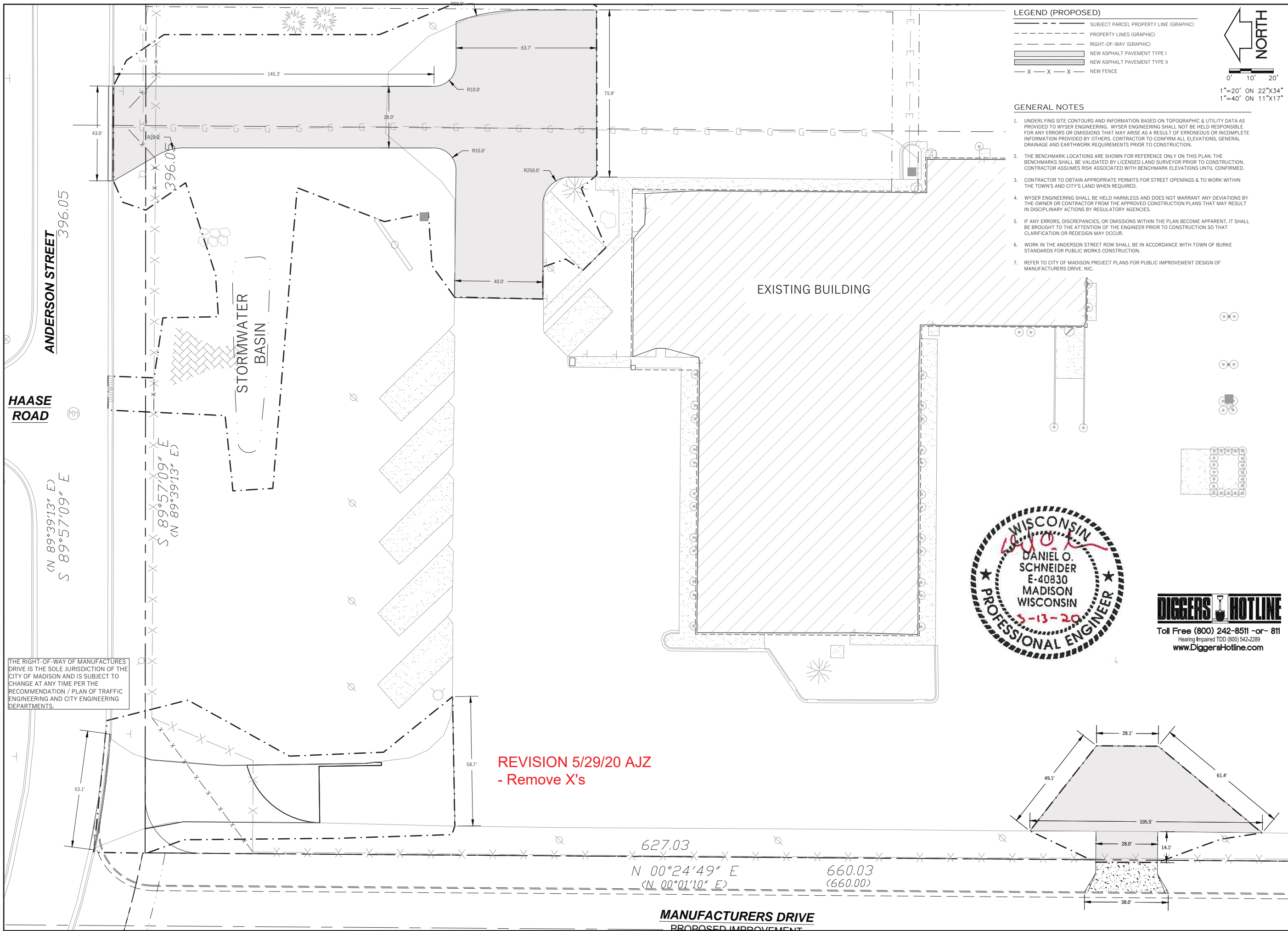

- LEGEND (PROPOSED)**
- SUBJECT PARCEL PROPERTY LINE (GRAPHIC)
  - PROPERTY LINES (GRAPHIC)
  - RIGHT-OF-WAY (GRAPHIC)
  - ▨ NEW ASPHALT PAVEMENT TYPE I
  - ▨ NEW ASPHALT PAVEMENT TYPE II
  - X - X - X - NEW FENCE

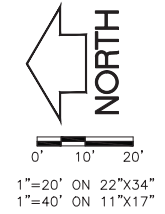

- GENERAL NOTES**
1. UNDERLYING SITE CONTOURS AND INFORMATION BASED ON TOPOGRAPHIC & UTILITY DATA AS PROVIDED TO WYSER ENGINEERING. WYSER ENGINEERING SHALL NOT BE HELD RESPONSIBLE FOR ANY ERRORS OR OMISSIONS THAT MAY ARISE AS A RESULT OF ERRONEOUS OR INCOMPLETE INFORMATION PROVIDED BY OTHERS. CONTRACTOR TO CONFIRM ALL ELEVATIONS, GENERAL DRAINAGE AND EARTHWORK REQUIREMENTS PRIOR TO CONSTRUCTION.
  2. THE BENCHMARK LOCATIONS ARE SHOWN FOR REFERENCE ONLY ON THIS PLAN. THE BENCHMARKS SHALL BE VALIDATED BY LICENSED LAND SURVEYOR PRIOR TO CONSTRUCTION. CONTRACTOR ASSUMES RISK ASSOCIATED WITH BENCHMARK ELEVATIONS UNTIL CONFIRMED.
  3. CONTRACTOR TO OBTAIN APPROPRIATE PERMITS FOR STREET OPENINGS & TO WORK WITHIN THE TOWN'S AND CITY'S LAND WHEN REQUIRED.
  4. WYSER ENGINEERING SHALL BE HELD HARMLESS AND DOES NOT WARRANT ANY DEVIATIONS BY THE OWNER OR CONTRACTOR FROM THE APPROVED CONSTRUCTION PLANS THAT MAY RESULT IN DISCIPLINARY ACTIONS BY REGULATORY AGENCIES.
  5. IF ANY ERRORS, DISCREPANCIES, OR OMISSIONS WITHIN THE PLAN BECOME APPARENT, IT SHALL BE BROUGHT TO THE ATTENTION OF THE ENGINEER PRIOR TO CONSTRUCTION SO THAT CLARIFICATION OR REDESIGN MAY OCCUR.
  6. WORK IN THE ANDERSON STREET ROW SHALL BE IN ACCORDANCE WITH TOWN OF BURKE STANDARDS FOR PUBLIC WORKS CONSTRUCTION.
  7. REFER TO CITY OF MADISON PROJECT PLANS FOR PUBLIC IMPROVEMENT DESIGN OF MANUFACTURERS DRIVE, NIC.

THE RIGHT-OF-WAY OF MANUFACTURERS DRIVE IS THE SOLE JURISDICTION OF THE CITY OF MADISON AND IS SUBJECT TO CHANGE AT ANY TIME PER THE RECOMMENDATION / PLAN OF TRAFFIC ENGINEERING AND CITY ENGINEERING DEPARTMENTS.

**REVISION 5/29/20 AJZ**  
- Remove X's

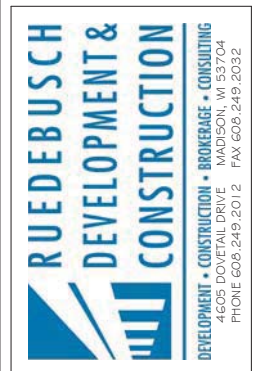
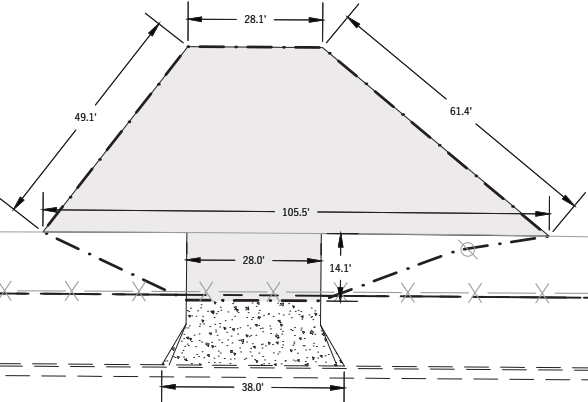

608.843.3388  
www.wyserengineering.com

**INDUSTRIAL DEVELOPMENT  
OFFSITE DRIVEWAY - TOWN  
OF BURKE**  
ANDERSON STREET  
BURKE, WISCONSIN

DATE:	
NO.	REVISION:

SHEET TITLE: LAYOUT PLAN ANDERSON STREET DRIVEWAY	
JOB NUMBER:	Project Number
DESIGNED BY:	DOS
DRAWN BY:	DOS
CHECKED BY:	WFW
DATE:	12.30.19
SHEET NO.:	

**C1.4**

**MANUFACTURERS DRIVE**  
PROPOSED IMPROVEMENT  
DESIGN BY CITY OF MADISON, NIC



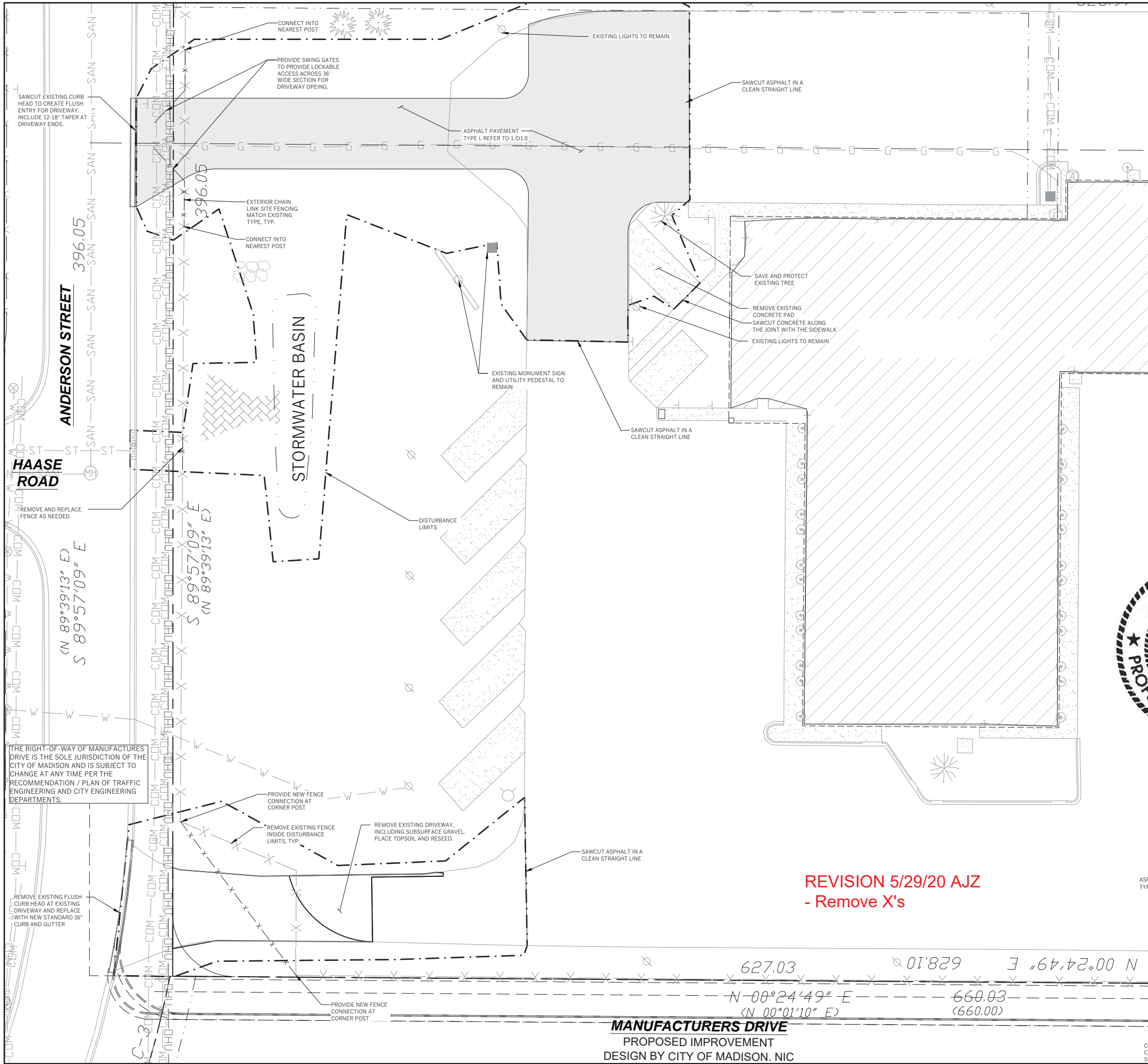

**LEGEND (PROPOSED)**

- SUBJECT PARCEL PROPERTY LINE (GRAPHIC)
- PROPERTY LINES (GRAPHIC)
- RIGHT-OF-WAY (GRAPHIC)
- ▨ NEW ASPHALT PAVEMENT TYPE I
- ▨ NEW ASPHALT PAVEMENT TYPE II
- X-X-X- NEW FENCE

**GENERAL NOTES**

- UNDERLYING SITE CONTOURS AND INFORMATION BASED ON TOPOGRAPHIC & UTILITY DATA AS PROVIDED TO WYSER ENGINEERING. WYSER ENGINEERING SHALL NOT BE HELD RESPONSIBLE FOR ANY ERRORS OR OMISSIONS THAT MAY ARISE AS A RESULT OF ERRONEOUS OR INCOMPLETE INFORMATION PROVIDED BY OTHERS. CONTRACTOR TO CONFIRM ALL ELEVATIONS, GENERAL DRAINAGE AND EARTHWORK REQUIREMENTS PRIOR TO CONSTRUCTION.
- THE BENCHMARK LOCATIONS ARE SHOWN FOR REFERENCE ONLY ON THIS PLAN. THE BENCHMARKS SHALL BE VALIDATED BY LICENSED LAND SURVEYOR PRIOR TO CONSTRUCTION. CONTRACTOR ASSUMES RISK ASSOCIATED WITH BENCHMARK ELEVATIONS UNTIL CONFIRMED.
- CONTRACTOR TO OBTAIN APPROPRIATE PERMITS FOR STREET OPENINGS & TO WORK WITHIN THE TOWN'S AND CITY'S LAND WHEN REQUIRED.
- WYSER ENGINEERING SHALL BE HELD HARMLESS AND DOES NOT WARRANT ANY DEVIATIONS BY THE OWNER OR CONTRACTOR FROM THE APPROVED CONSTRUCTION PLANS THAT MAY RESULT IN DISCIPLINARY ACTIONS BY REGULATORY AGENCIES.
- IF ANY ERRORS, DISCREPANCIES, OR OMISSIONS WITHIN THE PLAN BECOME APPARENT, IT SHALL BE BROUGHT TO THE ATTENTION OF THE ENGINEER PRIOR TO CONSTRUCTION SO THAT CLARIFICATION OR REDESIGN MAY OCCUR.
- WORK IN THE ANDERSON STREET ROW SHALL BE IN ACCORDANCE WITH TOWN OF BURKE STANDARDS FOR PUBLIC WORKS CONSTRUCTION.
- REFER TO CITY OF MADISON PROJECT PLANS FOR PUBLIC IMPROVEMENT DESIGN OF MANUFACTURERS DRIVE, NIC.

**GENERAL NOTES**

SITE ADDRESS: 4195 ANDERSON ROAD - TOWN OF BURKE  
 SITE ACREAGE (LOT 1 CSM 4929): 5.70 AC  
 USE OF PROPERTY: INDUSTRIAL  
 ZONING: HEAVY COMMERCIAL (HC)  
 ZONING: 10.273  
 HC-HEAVY COMMERCIAL - DANE COUNTY ZONING

SETBACKS: 10.273(6)  
 FRONT YARD: 30-FEET  
 BACK YARD: 10-FEET  
 SIDE YARD: 10-FEET

MAXIMUM IMPERVIOUS PERCENT: 60% - 10.273(7)  
 EXISTING PERCENT IMPERVIOUS: 73.7%  
 PROPOSED FINAL PERCENT IMPERVIOUS: 69.7%

EXISTING IMPERVIOUS AREA: 4.20 ACRES  
 REMOVED IMPERVIOUS AREA: 9,959 SQ.FT.  
 REDEVELOPED IMPERVIOUS AREA: 17,661 SQ.FT.  
 DISTURBANCE LIMITS: 37,750 SQ. FT.

1"=20' ON 22"x34"  
 1"=40' ON 11"x17"

**WISCONSIN PROFESSIONAL ENGINEER**  
 DANIEL O. SCHNEIDER  
 E-40830  
 MADISON WISCONSIN  
 5-13-20

**DIGGERS HOTLINE**  
 Toll Free (800) 242-8511 -or- 811  
 Hearing Impaired TDD (800) 542-2289  
 www.DiggersHotline.com

REVISION 5/29/20 AJZ  
 - Remove X's

ASPHALT PAVEMENT TYPE I, REFER TO 1/D1.0

SAWCUT ASPHALT IN A CLEAN STRAIGHT LINE

COMMERCIAL ENTRY PER CITY OF MADISON STANDARD DETAIL.

**RUEDEBUSCH DEVELOPMENT & CONSTRUCTION**

DEVELOPMENT • CONSTRUCTION • BROKERAGE • CONSULTING  
 4605 DOVETAIL DRIVE MADISON, WI 53704  
 PHONE 608.249.2012 FAX 608.249.2032

**WYSER ENGINEERING**

608.843.3388  
 www.wyserengineering.com

INDUSTRIAL DEVELOPMENT  
 OFFSITE DRIVEWAY - TOWN OF BURKE  
 ANDERSON STREET  
 BURKE, WISCONSIN

DATE:	
NO.	REVISION:
SHEET TITLE: LAYOUT PLAN ANDERSON STREET DRIVEWAY	
JOB NUMBER:	Project Number
DESIGNED BY:	DOS
DRAWN BY:	DOS
CHECKED BY:	WFW
DATE:	12.30.19
SHEET NO.:	

C2.4

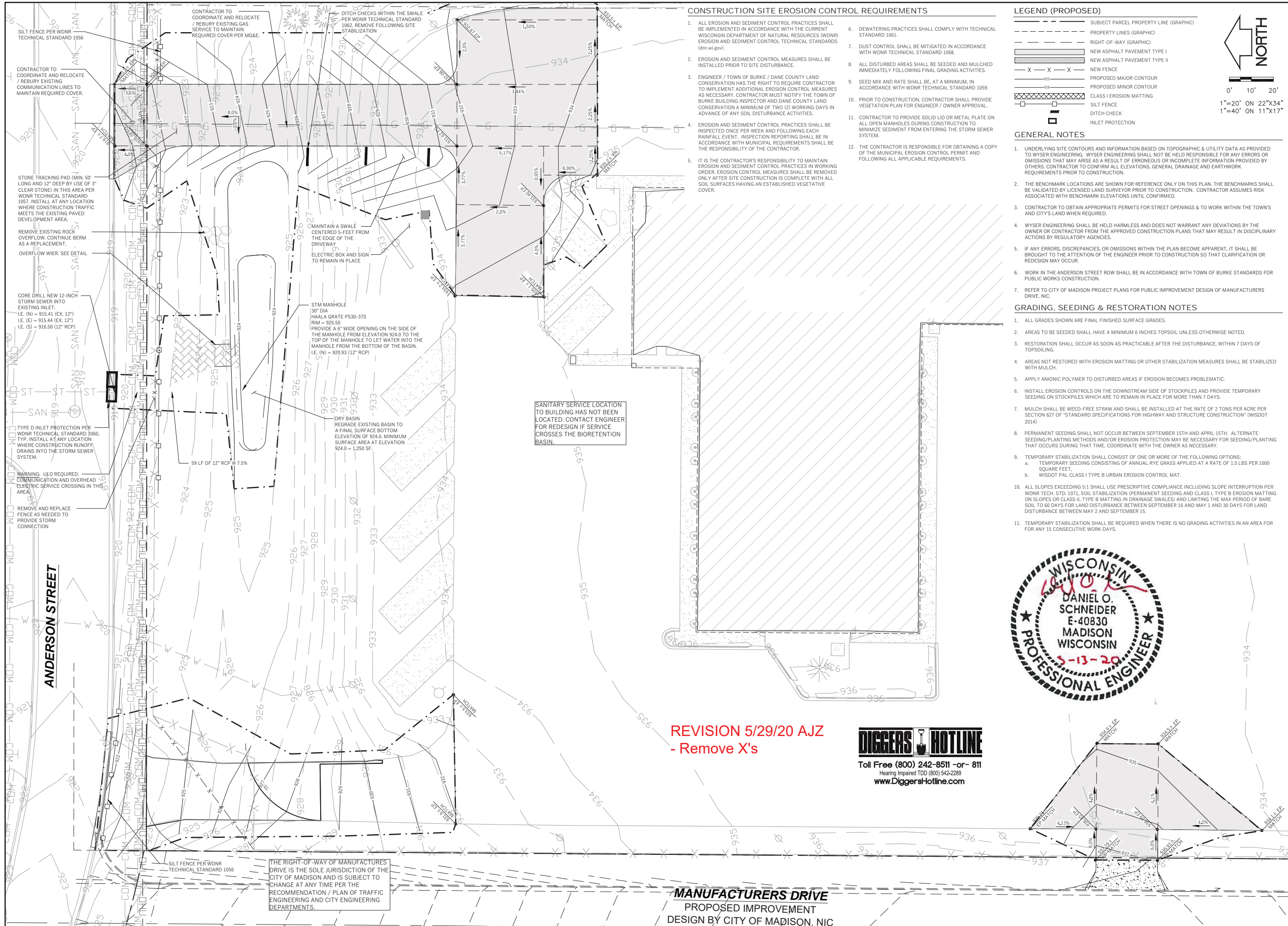

**CONSTRUCTION SITE EROSION CONTROL REQUIREMENTS**

1. ALL EROSION AND SEDIMENT CONTROL PRACTICES SHALL BE IMPLEMENTED IN ACCORDANCE WITH THE CURRENT WISCONSIN DEPARTMENT OF NATURAL RESOURCES (WDNR) EROSION AND SEDIMENT CONTROL TECHNICAL STANDARDS (dnr.wis.gov).
2. EROSION AND SEDIMENT CONTROL MEASURES SHALL BE INSTALLED PRIOR TO SITE DISTURBANCE.
3. ENGINEER / TOWN OF BURKE / DAINE COUNTY LAND CONSERVATION HAS THE RIGHT TO REQUIRE CONTRACTOR TO IMPLEMENT ADDITIONAL EROSION CONTROL MEASURES AS NECESSARY. CONTRACTOR MUST NOTIFY THE TOWN OF BURKE BUILDING INSPECTOR AND DAINE COUNTY LAND CONSERVATION A MINIMUM OF TWO (2) WORKING DAYS IN ADVANCE OF ANY SOIL DISTURBANCE ACTIVITIES.
4. EROSION AND SEDIMENT CONTROL PRACTICES SHALL BE INSPECTED ONCE PER WEEK AND FOLLOWING EACH RAINFALL EVENT. INSPECTION REPORTING SHALL BE IN ACCORDANCE WITH MUNICIPAL REQUIREMENTS SHALL BE THE RESPONSIBILITY OF THE CONTRACTOR.
5. IT IS THE CONTRACTOR'S RESPONSIBILITY TO MAINTAIN EROSION AND SEDIMENT CONTROL PRACTICES IN WORKING ORDER. EROSION CONTROL MEASURES SHALL BE REMOVED ONLY AFTER SITE CONSTRUCTION IS COMPLETE WITH ALL SOIL SURFACES HAVING AN ESTABLISHED VEGETATIVE COVER.
6. DEWATERING PRACTICES SHALL COMPLY WITH TECHNICAL STANDARD 1061.
7. DUST CONTROL SHALL BE MITIGATED IN ACCORDANCE WITH WDNR TECHNICAL STANDARD 1068.
8. ALL DISTURBED AREAS SHALL BE SEEDED AND MULCHED IMMEDIATELY FOLLOWING FINAL GRADING ACTIVITIES.
9. SEED MIX AND RATE SHALL BE, AT A MINIMUM, IN ACCORDANCE WITH WDNR TECHNICAL STANDARD 1059.
10. PRIOR TO CONSTRUCTION, CONTRACTOR SHALL PROVIDE VEGETATION PLAN FOR ENGINEER / OWNER APPROVAL.
11. CONTRACTOR TO PROVIDE SOLID LID OR METAL PLATE ON ALL OPEN MANHOLES DURING CONSTRUCTION TO MINIMIZE SEDIMENT FROM ENTERING THE STORM SEWER SYSTEM.
12. THE CONTRACTOR IS RESPONSIBLE FOR OBTAINING A COPY OF THE MUNICIPAL EROSION CONTROL PERMIT AND FOLLOWING ALL APPLICABLE REQUIREMENTS.

**LEGEND (PROPOSED)**

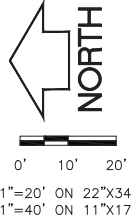
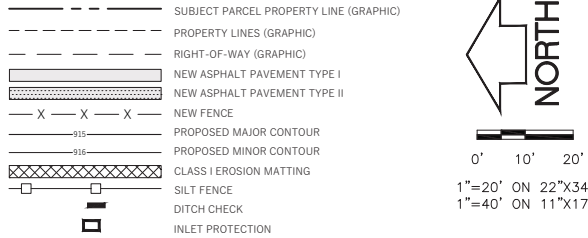

**GENERAL NOTES**

1. UNDERLYING SITE CONTOURS AND INFORMATION BASED ON TOPOGRAPHIC & UTILITY DATA AS PROVIDED TO WYSER ENGINEERING. WYSER ENGINEERING SHALL NOT BE HELD RESPONSIBLE FOR ANY ERRORS OR OMISSIONS THAT MAY ARISE AS A RESULT OF ERRONEOUS OR INCOMPLETE INFORMATION PROVIDED BY OTHERS. CONTRACTOR TO CONFIRM ALL ELEVATIONS, GENERAL DRAINAGE AND EARTHWORK REQUIREMENTS PRIOR TO CONSTRUCTION.
2. THE BENCHMARK LOCATIONS ARE SHOWN FOR REFERENCE ONLY ON THIS PLAN. THE BENCHMARKS SHALL BE VALIDATED BY LICENSED LAND SURVEYOR PRIOR TO CONSTRUCTION. CONTRACTOR ASSUMES RISK ASSOCIATED WITH BENCHMARK ELEVATIONS UNTIL CONFIRMED.
3. CONTRACTOR TO OBTAIN APPROPRIATE PERMITS FOR STREET OPENINGS & TO WORK WITHIN THE TOWN'S AND CITY'S LAND WHEN REQUIRED.
4. WYSER ENGINEERING SHALL BE HELD HARMLESS AND DOES NOT WARRANT ANY DEVIATIONS BY THE OWNER OR CONTRACTOR FROM THE APPROVED CONSTRUCTION PLANS THAT MAY RESULT IN DISCIPLINARY ACTIONS BY REGULATORY AGENCIES.
5. IF ANY ERRORS, DISCREPANCIES, OR OMISSIONS WITHIN THE PLAN BECOME APPARENT, IT SHALL BE BROUGHT TO THE ATTENTION OF THE ENGINEER PRIOR TO CONSTRUCTION SO THAT CLARIFICATION OR REDESIGN MAY OCCUR.
6. WORK IN THE ANDERSON STREET ROW SHALL BE IN ACCORDANCE WITH TOWN OF BURKE STANDARDS FOR PUBLIC WORKS CONSTRUCTION.
7. REFER TO CITY OF MADISON PROJECT PLANS FOR PUBLIC IMPROVEMENT DESIGN OF MANUFACTURERS DRIVE, NIC.

**GRADING, SEEDING & RESTORATION NOTES**

1. ALL GRADES SHOWN ARE FINAL FINISHED SURFACE GRADES.
2. AREAS TO BE SEEDED SHALL HAVE A MINIMUM 6 INCHES TOPSOIL UNLESS OTHERWISE NOTED.
3. RESTORATION SHALL OCCUR AS SOON AS PRACTICABLE AFTER THE DISTURBANCE, WITHIN 7 DAYS OF TOPSOILING.
4. AREAS NOT RESTORED WITH EROSION MATTING OR OTHER STABILIZATION MEASURES SHALL BE STABILIZED WITH MULCH.
5. APPLY ANIONIC POLYMER TO DISTURBED AREAS IF EROSION BECOMES PROBLEMATIC.
6. INSTALL EROSION CONTROLS ON THE DOWNSTREAM SIDE OF STOCKPILES AND PROVIDE TEMPORARY SEEDING/PLANTING METHODS WHICH ARE TO REMAIN IN PLACE FOR MORE THAN 7 DAYS.
7. MULCH SHALL BE WEED-FREE STRAW AND SHALL BE INSTALLED AT THE RATE OF 2 TONS PER ACRE PER SECTION 627 OF "STANDARD SPECIFICATIONS FOR HIGHWAY AND STRUCTURE CONSTRUCTION" (WISDOT 2014)
8. PERMANENT SEEDING SHALL NOT OCCUR BETWEEN SEPTEMBER 15TH AND APRIL 15TH. ALTERNATE SEEDING/PLANTING METHODS AND/OR EROSION PROTECTION MAY BE NECESSARY FOR SEEDING/PLANTING THAT OCCURS DURING THAT TIME. COORDINATE WITH THE OWNER AS NECESSARY.
9. TEMPORARY STABILIZATION SHALL CONSIST OF ONE OR MORE OF THE FOLLOWING OPTIONS:
  - a. TEMPORARY SEEDING CONSISTING OF ANNUAL RYE GRASS APPLIED AT A RATE OF 1.5 LBS PER 1000 SQUARE FEET.
  - b. WISDOT PAL CLASS I TYPE B URBAN EROSION CONTROL MAT.
10. ALL SLOPES EXCEEDING 5:1 SHALL USE PRESCRIPTIVE COMPLIANCE INCLUDING SLOPE INTERRUPTION PER WDNR TECH. STD. 1071, SOIL STABILIZATION (PERMANENT SEEDING AND CLASS I, TYPE B EROSION MATTING ON SLOPES OR CLASS II, TYPE B MATTING IN DRAINAGE SWALES) AND LIMITING THE MAX PERIOD OF BARE SOIL TO 60 DAYS FOR LAND DISTURBANCE BETWEEN SEPTEMBER 16 AND MAY 1 AND 30 DAYS FOR LAND DISTURBANCE BETWEEN MAY 2 AND SEPTEMBER 15.
11. TEMPORARY STABILIZATION SHALL BE REQUIRED WHEN THERE IS NO GRADING ACTIVITIES IN AN AREA FOR ANY 15 CONSECUTIVE WORK DAYS.



**REVISION 5/29/20 AJZ**  
- Remove X's



**MANUFACTURERS DRIVE**  
PROPOSED IMPROVEMENT  
DESIGN BY CITY OF MADISON, NIC

**RUEDEBUSCH DEVELOPMENT & CONSTRUCTION**

DEVELOPMENT • CONSTRUCTION • BROKERAGE • CONSULTING  
4605 DOVETAIL DRIVE MADISON, WI 53704  
PHONE 608.249.2012 FAX 608.249.2032

**WYSER ENGINEERING**

608.843.3388  
www.wyserengineering.com

**INDUSTRIAL DEVELOPMENT  
OFFSITE DRIVEWAY - TOWN  
OF BURKE**

ANDERSON STREET  
BURKE, WISCONSIN

DATE:	
NO. REVISION:	
SHEET TITLE:	GRADING, UTILITY & EROSION CONTROL PLAN ANDERSON STREET DRIVEWAY
JOB NUMBER:	Project Number
DESIGNED BY:	DOS
DRAWN BY:	DOS
CHECKED BY:	WFW
DATE:	12.30.19
SHEET NO.:	C3.9

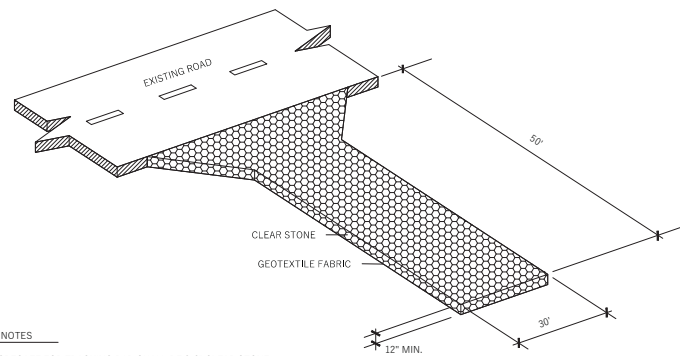

- MATERIAL NOTES**
1. THE AGGREGATE FOR TRACKING PAD SHALL BE 3-6" CLEAR STONE.
  2. THE TRACKING PAD SHALL BE UNDERLAIN WITH A WOOD TYPE R GEOTEXTILE FABRIC.

**INSTALLATION NOTES**

1. INSTALLATION SHALL CONFORM WITH THE REQUIREMENTS OF WDNR CONSERVATION PRACTICE STANDARD 1057.
2. THE TRACKING PAD SHALL BE INSTALLED PRIOR TO ANY TRAFFIC LEAVING THE SITE. STONE TRACKING PAD SHALL BE USED AT ALL POINTS OF CONSTRUCTION EGRESS.
3. DIMENSIONS OF THE TRACKING PAD SHALL BE MINIMUM AS NOTED ON THE FIGURE ABOVE.
4. SURFACE WATER SHALL BE PREVENTED FROM PASSING THROUGH THE TRACKING PAD. FLOWS SHALL BE DIVERTED AWAY FROM TRACKING PADS OR CONVEYED UNDER AND AROUND THEM USING CULVERTS OR OTHER PRACTICES.
5. TRACKING PAD SHALL BE REMOVED OR INCORPORATED INTO GRAVEL DRIVEWAY ONLY AFTER CONSTRUCTION IS COMPLETE AND THE SITE HAS BEEN STABILIZED.

**INSPECTION & MAINTENANCE NOTES**

1. STONE TRACKING PADS SHALL BE INSPECTED WEEKLY AND WITHIN 24 HOURS AFTER EVERY PRECIPITATION EVENT THAT PRODUCES 0.5 INCHES OF RAIN OR MORE DURING A 24 HOUR PERIOD.
2. ADDITIONAL AGGREGATE SHALL BE PLACED IF THE TRACKING PAD BECOMES BURIED OR IF SEDIMENT IS NOT BEING REMOVED EFFECTIVELY FROM THE VEHICLE TIRES.
3. A MINIMUM 30-FOOT WIDE BY 50-FOOT LONG BY 12-INCH THICK PAD SHALL BE MAINTAINED AT ALL TIMES.
4. THE TRACKING PAD PERFORMANCE SHALL BE MAINTAINED BY SCRAPING OR TOP-DRESSING WITH ADDITIONAL AGGREGATE.
5. ANY SEDIMENT TRACKED ONTO A PUBLIC OR PRIVATE ROAD SHOULD BE REMOVED BY STREET CLEANING AT THE END OF EACH WORKING DAY.
6. MAINTENANCE SHALL BE COMPLETED AS SOON AS POSSIBLE WITH CONSIDERATION FOR SITE CONDITIONS.

CONSTRUCTION ENTRANCE (TRACKING PAD)

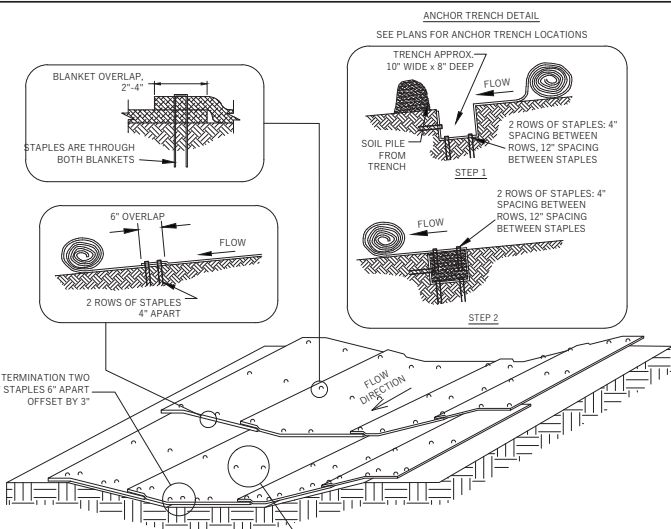

- MATERIAL NOTES**
1. ONLY PRODUCTS LISTED IN THE WISCONSIN DEPARTMENT OF TRANSPORTATION EROSION CONTROL PRODUCT ACCEPTABILITY LIST (PAL) ARE ACCEPTABLE FOR USE.
  2. STAPLES USED FOR CLASS I TYPES A & B MATS SHALL BE 1-2 INCH WIDE, U-SHAPED, MADE OF NO. 11 (3.05mm) OR LARGER DIAMETER STEEL WIRE, AND NOT LESS THAN 6 INCHES LONG FOR FIRM SOILS AND 12 INCHES LONG FOR LOOSE SOILS.

**INSTALLATION NOTES**

1. EROSION CONTROL REVEGETATIVE MATS (ECRM) SHALL BE INSTALLED AFTER TOPSOIL AND SEED HAVE BEEN PLACED.
2. INSTALLATION OF ECRM SHOULD BE COORDINATED WITH PERMANENT RESTORATION PRACTICES.
3. INSTALLATION SHALL CONFORM WITH WDNR CONSERVATION PRACTICE STANDARD 1053.
4. ALL PRODUCTS SHALL BE INSTALLED PER THE MANUFACTURERS

- RECOMMENDATIONS. THIS STANDARD DETAIL IS AN EXAMPLE OF TYPICAL INSTALLATION GUIDANCE.
5. MATS SHALL BE IN FIRM AND CONTINUOUS CONTACT WITH THE SOIL.
  6. IF SECTIONS OF ECRM NEED TO BE OVERLAPPED, ENSURE THAT THE OVERLAP IS FACING DOWNSTREAM TO PREVENT WATER FROM FLOWING BENEATH THE ECRM.

**INSPECTION & MAINTENANCE NOTES**

1. INSTALL ADDITIONAL ANCHORING IN AREAS OF OBSERVED RILLING AND CONCENTRATED FLOW BENEATH THE EROSION MAT. IF RILLING IS SEVERE ENOUGH TO PREVENT VEGETATION ESTABLISHMENT, REMOVE EROSION MAT, REGRADE, COMPACT, RE-SEED, AND REPLACE THE SECTION OF MAT.
2. IF PRODUCTS WITH PLASTIC NETTING ARE USED, REMOVE NETTING OR REPLACE MAT IF SEPARATION OF THE NETTING FROM THE MAT IS OBSERVED.
3. ALL MAINTENANCE ACTIVITIES SHOULD OCCUR AS SOON AS POSSIBLE WITH CONSIDERATION OF SITE CONDITIONS.

EROSION CONTROL MAT (CHANNELS)

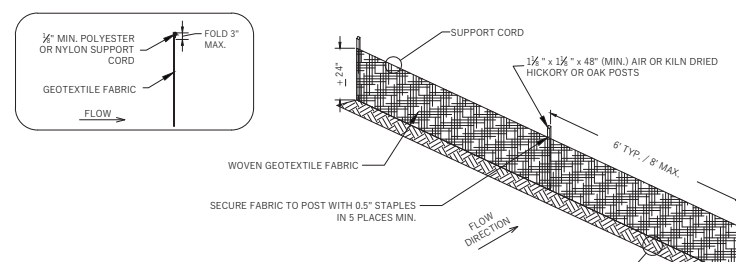

**MATERIAL NOTES**

1. GEOTEXTILE FABRIC SHALL BE WOVEN AND SHALL CONFORM TO THE MATERIAL REQUIREMENTS LISTED IN SECTION 628 OF THE WISDOT STANDARD SPECIFICATIONS FOR HIGHWAY AND STRUCTURE CONSTRUCTION, 2003 EDITION.

**INSTALLATION NOTES**

1. INSTALLATION SHALL CONFORM WITH THE REQUIREMENTS OF WDNR CONSERVATION PRACTICE STANDARD 1056.
2. CONSTRUCT THE SILT FENCE IN AN ARC WITH THE ENDS POINTING UPSLOPE TO AVOID EROSION AROUND THE ENDS OF THE FENCE.
3. FAILURE TO PROPERLY ANCHOR SILT FENCE COULD RESULT IN WATER AND SEDIMENT RELEASE BENEATH THE SILT FENCE. PROPERLY SECURE THE SILT FENCE INTO THE ANCHOR TRENCH.
4. CONSTRUCT THE FENCE FROM A CONTINUOUS ROLL OF GEOTEXTILE TO AVOID JOINTS. WHERE JOINTS ARE NECESSARY, OVERLAP TO THE NEXT POST OR WRAP ADJOINING FABRICS TOGETHER AROUND THE JOINT POST AND TIGHTLY FASTEN.
5. SILT FENCE SHALL NOT BE USED IN AREAS OF CONCENTRATED FLOW.

**INSPECTION & MAINTENANCE NOTES**

1. AT A MINIMUM, PERFORM INSPECTIONS WEEKLY AND WITHIN 24 HOURS OF PRECIPITATION EVENTS PRODUCING 0.5 INCHES OR MORE OF RAINFALL.
2. INSPECT FENCES FOR DAMAGE TO STAKES AND FABRIC, UNDERCUTTING, EXCESSIVE SEDIMENT ACCUMULATION (GREATER THAN 1/2 OF THE FENCE HEIGHT), AND INDICATIONS OF SCOUR AROUND THE EDGES.
3. REPAIR OR REPLACE SILT FENCE WITHIN 24 HOURS OF IDENTIFYING AND DEFICIENCIES.

SILT FENCE

FLEXSTORM INLET FILTERS TO MEET DANE COUNTY EROSION CONTROL STANDARDS

**(HB) HYBRID FILTER BAG SPECIFICATIONS:**

PRODUCT	102 9x10	1000N 10x10	ADN W/WHN 10x10
STABLE DRAINAGE	457M10A02	457M10A02	457M10A02
CONCRETE	457M10A02	457M10A02	457M10A02
CONCRETE	457M10A02	457M10A02	457M10A02
CONCRETE	457M10A02	457M10A02	457M10A02
CONCRETE	457M10A02	457M10A02	457M10A02
CONCRETE	457M10A02	457M10A02	457M10A02
CONCRETE	457M10A02	457M10A02	457M10A02
CONCRETE	457M10A02	457M10A02	457M10A02
CONCRETE	457M10A02	457M10A02	457M10A02
CONCRETE	457M10A02	457M10A02	457M10A02
CONCRETE	457M10A02	457M10A02	457M10A02

**CATCH-IT INLET FILTER (Temporary Inlet Protection)**

Nestah Casting	Inlet Type	Grate Size	Opening Size	Bag Cap (ft)	Flow Ratings (CFS)	ADS PIN
3087	Curb Box	35.25 x 17.75	33.0 x 15.0	4.4	2.0 5.8	62LCBEX1HB
3246A	Curb Box	35.75 x 23.875	33.5 x 21.0	4.2	1.1 3.3	62LCB3624HB
3030	Square/Rect (SQ)	23 x 16	20.5 x 13.5	1.8	0.7 2.2	62MCR2316HB
3087-C	Square/Rect (SQ)	35.25 x 17.75	33 x 15	3.2	1.0 5.2	62LSC3818HB
R-2501	Round (RD)	-26	-24	2.3	0.8 5.2	62MRD26HB
R-1772/2560	Round (RD)	22.25-23.5	20.5-21	1.5	0.6 4.6	62MRD22HB

**Installation Instructions:**

1. Remove grate from the drainage structure
2. Clean stone and dirt from ledge (lip) of drainage structure
3. Drop the inlet filter through the clear opening such that the hangers rest firmly on the lip of the structure
4. Replace the grate and confirm it is not elevated more than 1/8"

**Maintenance Guidelines:**

1. Empty the sediment bag if more than half filled with sediment and debris
2. Remove the grate, engage the lifting points, and lift filter from the drainage structure
3. Dispose of sediment and debris as directed by the Engineer or Maintenance Contract
4. Alternatively, an industrial vacuum can be used to collect sediment from filter bag

**FLEXSTORM CATCH-IT**

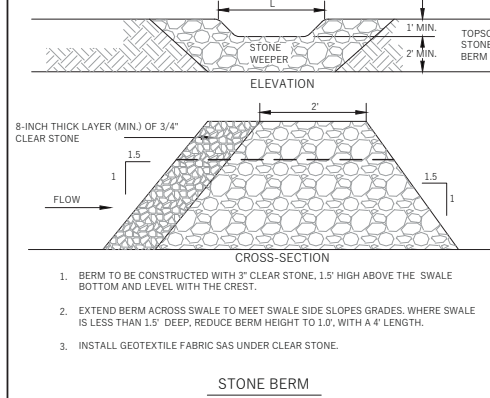

1. BERM TO BE CONSTRUCTED WITH 3" CLEAR STONE, 1.5' HIGH ABOVE THE SWALE BOTTOM AND LEVEL WITH THE CREST.
2. EXTEND BERM ACROSS SWALE TO MEET SWALE SIDE SLOPES GRADES. WHERE SWALE IS LESS THAN 1.5' DEEP, REDUCE BERM HEIGHT TO 1.0', WITH A 4" LENGTH.
3. INSTALL GEOTEXTILE FABRIC SAS UNDER CLEAR STONE.

STONE BERM

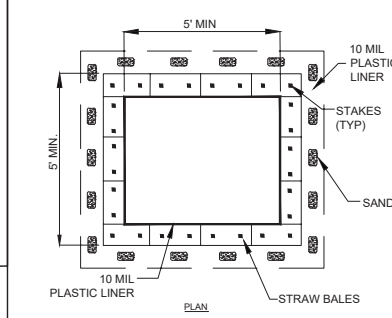

**WASHOUT NOTES**

1. ALTERNATIVE CONCRETE WASHOUTS ALLOWABLE AS APPROVED BY ENGINEER, INCLUDING DISPOSABLE WASHOUTS, ETC.
2. NO WASHING OUT OF CONCRETE TRUCKS OR WASHING OF SWEEPINGS FROM EXPOSED AGGREGATE CONCRETE INTO STORM DRAINS, OPEN DITCHES, STREETS, OR STREAMS IS ALLOWED.
3. EXCESS CONCRETE IS NOT ALLOWED TO BE DUMPED ON-SITE, EXCEPT IN DESIGNATED TEMPORARY CONCRETE WASHOUT PIT AREAS.
4. ON-SITE TEMPORARY CONCRETE WASHOUT AREAS WILL BE LOCATED AT LEAST 60 FEET FROM STORM DRAINS, OPEN DITCHES, OR WATER BODIES AS DETERMINED IN THE FIELD.
5. TEMPORARY CONCRETE WASHOUT FACILITIES WILL BE CONSTRUCTED AND MAINTAINED IN SUFFICIENT QUANTITY AND SIZE TO CONTAIN ALL LIQUID AND CONCRETE WASTE GENERATED BY WASHOUT OPERATIONS.
6. WASHOUT FACILITIES WILL BE CLEANED OUT OR REPLACED ONCE THE WASHOUT IS 75% FULL.
7. PLASTIC LINING MATERIAL WILL BE MINIMUM OF 10 MIL POLYETHYLENE SHEETING AND WILL BE FREE OF HOLES, TEARS, OR OTHER DEFECTS.
8. WHEN WASHOUT FACILITIES ARE NO LONGER REQUIRED FOR WORK, THE HARDENED CONCRETE WILL BE REMOVED AND DISPOSED OF OFF-SITE. MATERIALS USED TO CONSTRUCT TEMPORARY CONCRETE WASHOUT FACILITIES WILL BE REMOVED FROM THE SITE AND DISPOSED OF.

CONCRETE WASHOUT

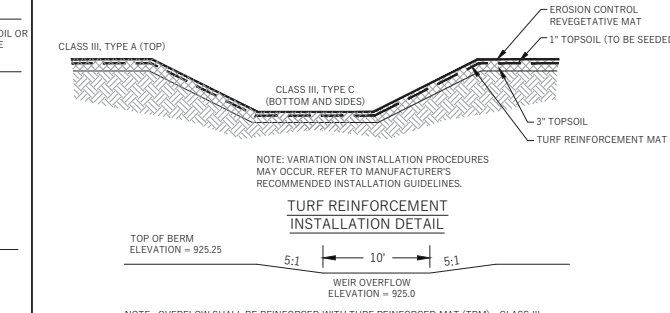

**TURF REINFORCEMENT INSTALLATION DETAIL**

NOTE: VARIATION ON INSTALLATION PROCEDURES MAY OCCUR. REFER TO MANUFACTURER'S RECOMMENDED INSTALLATION GUIDELINES.

TOP OF BERM ELEVATION = 925.25

WEIR OVERFLOW ELEVATION = 925.0

NOTE: OVERFLOW SHALL BE REINFORCED WITH TURF REINFORCED MAT (TRM) - CLASS III, TYPE C BY PYRAMAT OR APPROVED EQUAL. TRM SHALL BE INSTALLED PER MANUFACTURER'S RECOMMENDATIONS.

BIORETENTION BASIN OVERFLOW WEIR

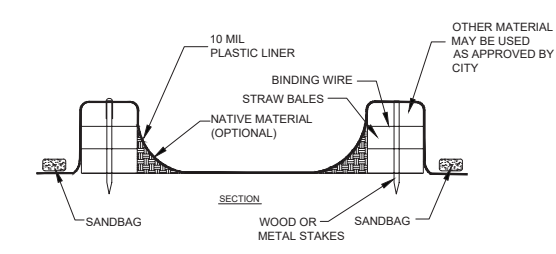

REVISION 5/29/20 AJZ  
- Remove X's



INDUSTRIAL DEVELOPMENT OFFSITE DRIVEWAY - TOWN OF BURKE  
MANUFACTURERS DRIVE MADISON, WISCONSIN

NO.	REVISION

SHEET TITLE:	DETAILS
JOB NUMBER:	Project Number
DESIGNED BY:	DOS
DRAWN BY:	DOS
CHECKED BY:	WPW
DATE:	12.30.19
SHEET NO.:	

D1.5

**REVISION 6/19/20 AJZ**  
- Revised TC Grades  
- Added DW Info

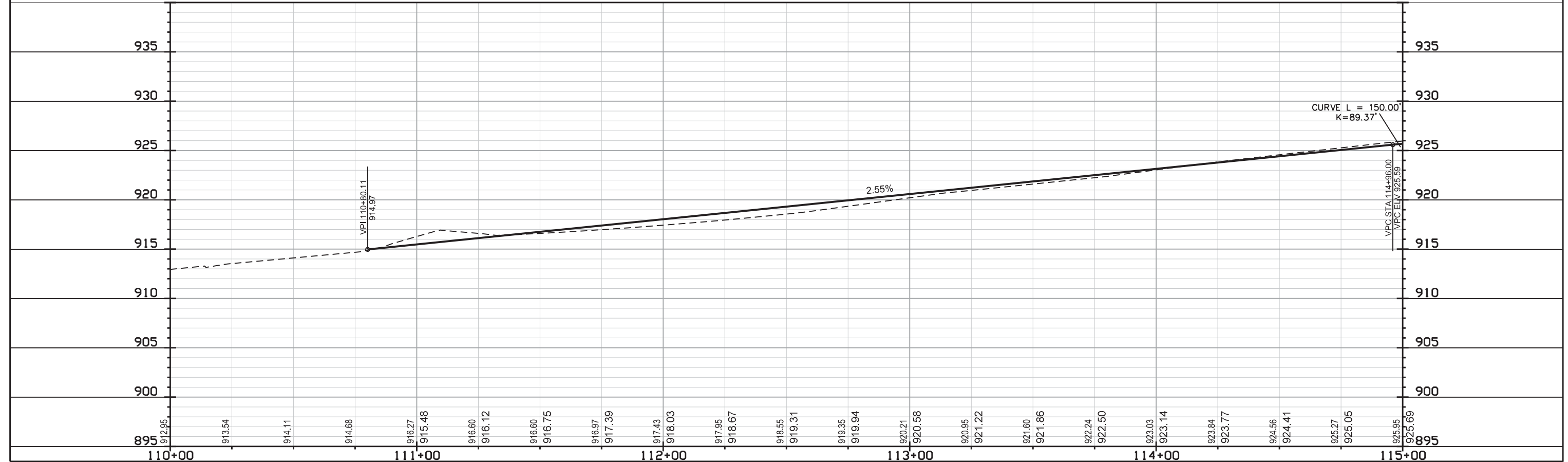
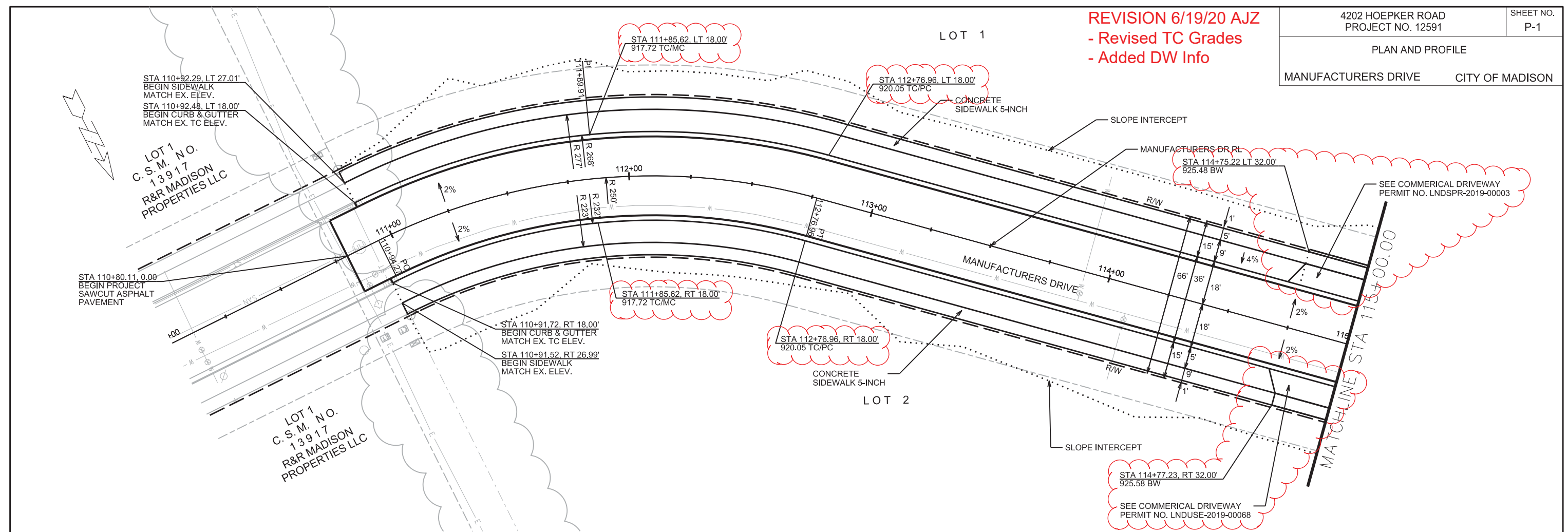

PLOT SCALE: \_\_\_\_\_  
PLOT NAME: \_\_\_\_\_  
REV. DATE: \_\_\_\_\_  
ORIGINATOR: CITY OF MADISON, STREETS DIVISION

REVISION 6/19/20 AJZ  
- Added DW Info  
REVISION 7/13/20 AJZ  
- Revised DW Info

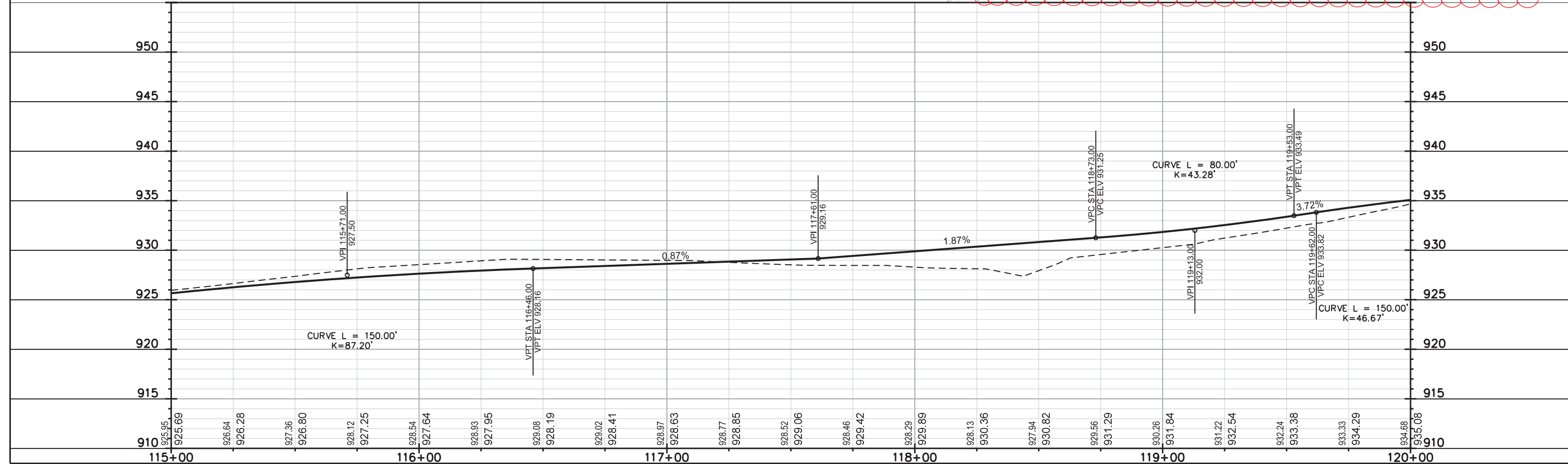
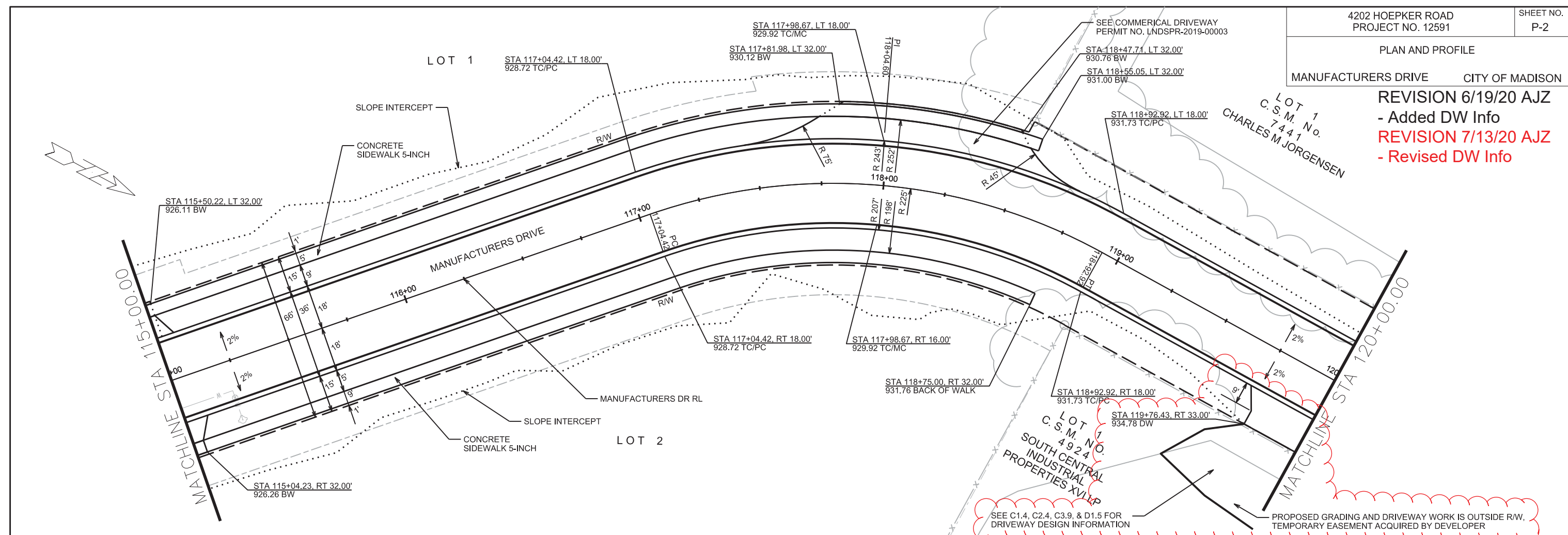

PLOT SCALE: \_\_\_\_\_  
 PLOT NAME: \_\_\_\_\_  
 REV. DATE: \_\_\_\_\_  
 ORIGINATOR: CITY OF MADISON, STREETS DIVISION

PLAN AND PROFILE  
MANUFACTURERS DRIVE CITY OF MADISON

- REVISION 5/1/20 AJZ  
- Added Note About Street Opening  
- Added Note Temporary Easement Acquired  
- Remove X's  
REVISION 6/19/20 AJZ  
- Revised TC Grades  
REVISION 7/13/20 AJZ  
- Revised DW Info

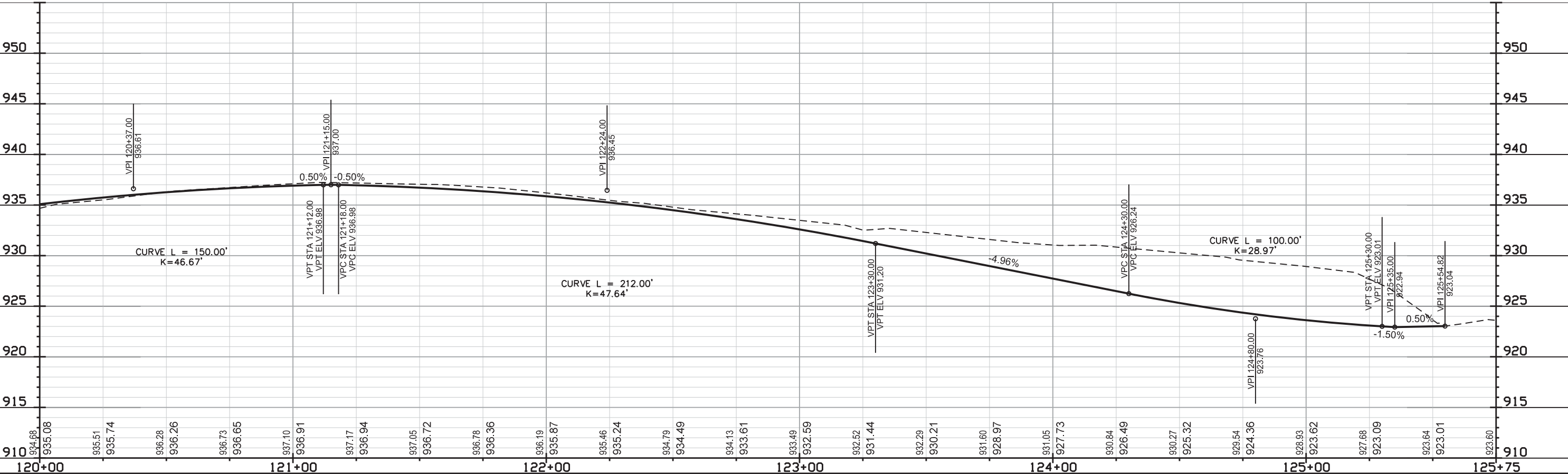
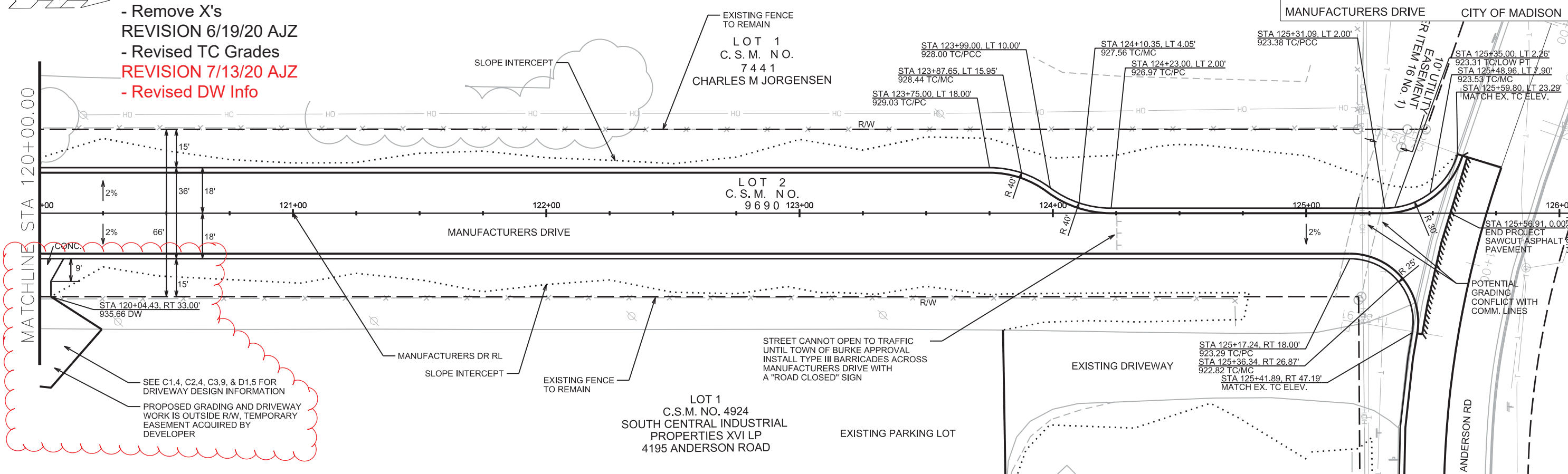

PLOT SCALE: \_\_\_\_\_ PLOT NAME: \_\_\_\_\_ REV. DATE: \_\_\_\_\_ ORIGINATOR: CITY OF MADISON, STREETS DIVISION

PLAN AND PROFILE  
ANDERSON ROAD CITY OF MADISON

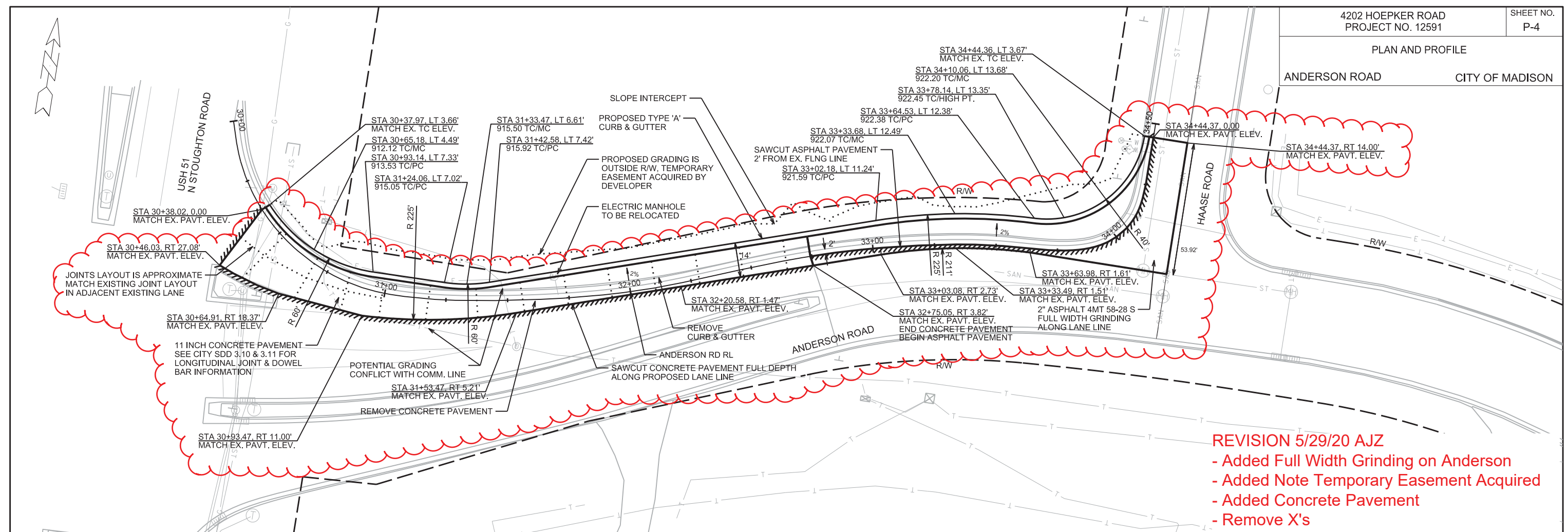

**REVISION 5/29/20 AJZ**

- Added Full Width Grinding on Anderson
- Added Note Temporary Easement Acquired
- Added Concrete Pavement
- Remove X's

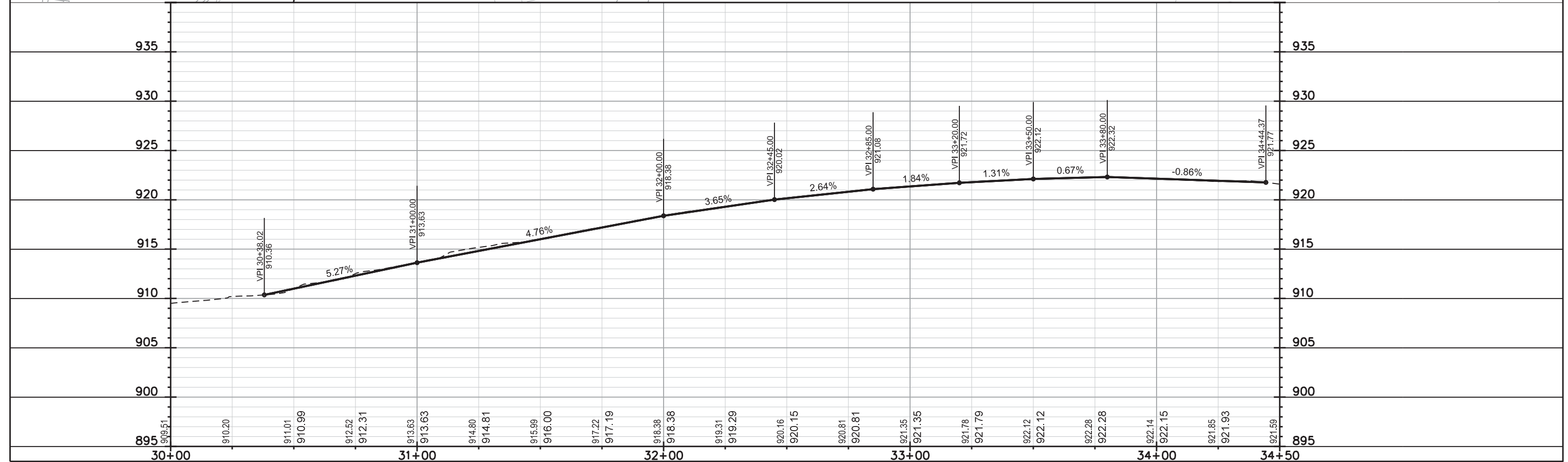

PLOT SCALE: \_\_\_\_\_

PLOT NAME: \_\_\_\_\_

REV. DATE: \_\_\_\_\_

ORIGINATOR: CITY OF MADISON, STREETS DIVISION

PLAN AND PROFILE

HOEPKER ROAD/USH 51 CITY OF MADISON

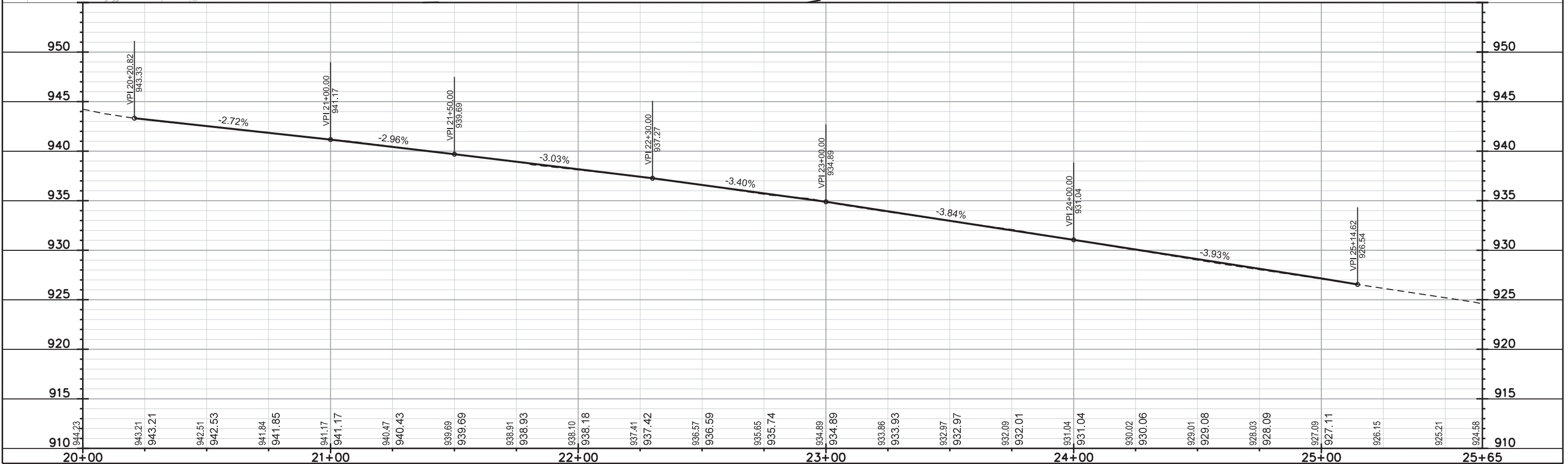
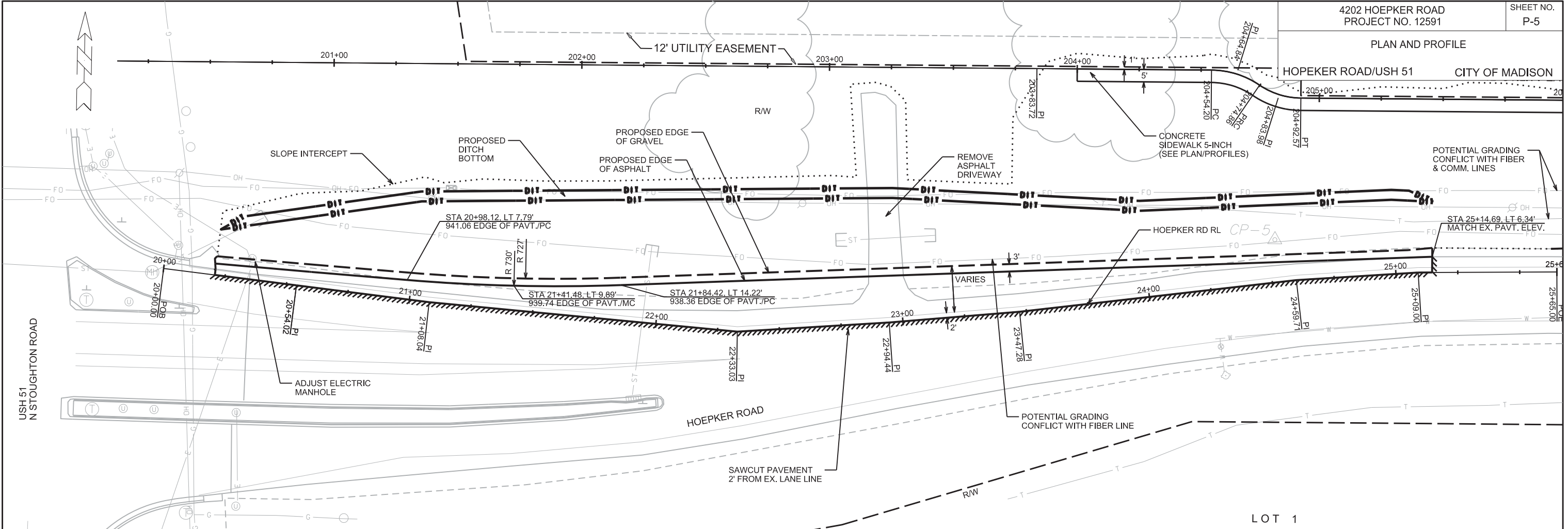

PLOT SCALE: \_\_\_\_\_

PLOT NAME: \_\_\_\_\_

REV. DATE: \_\_\_\_\_

ORIGINATOR: CITY OF MADISON, STREETS DIVISION



PLAN AND PROFILE  
HOEPKER ROAD/  
MANUFACTURERS DRIVE CITY OF MADISON

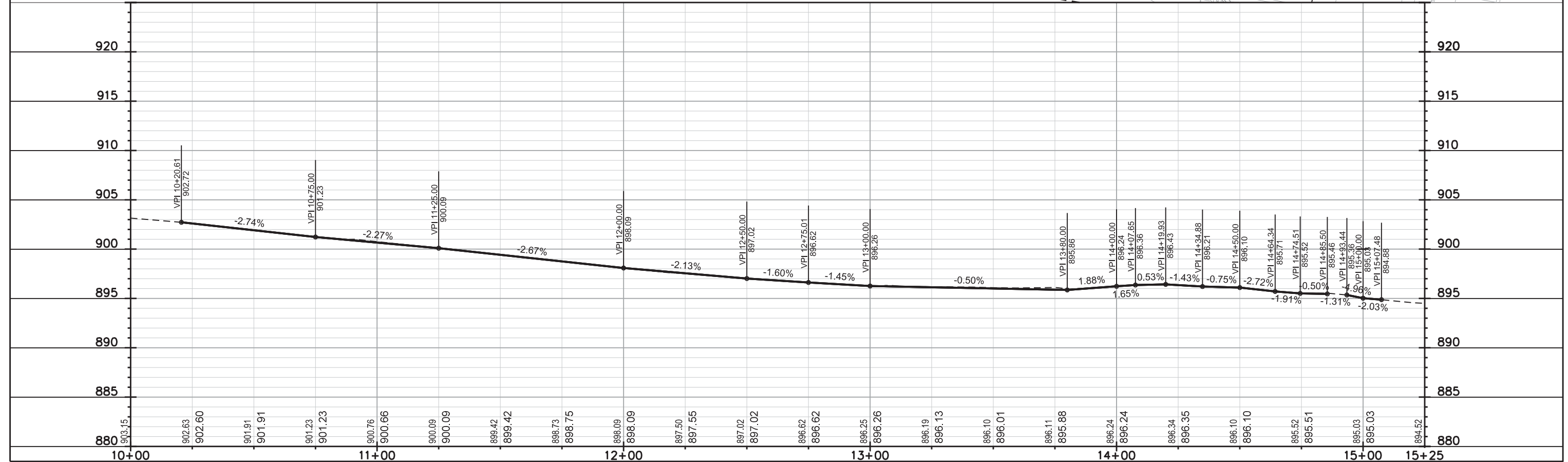
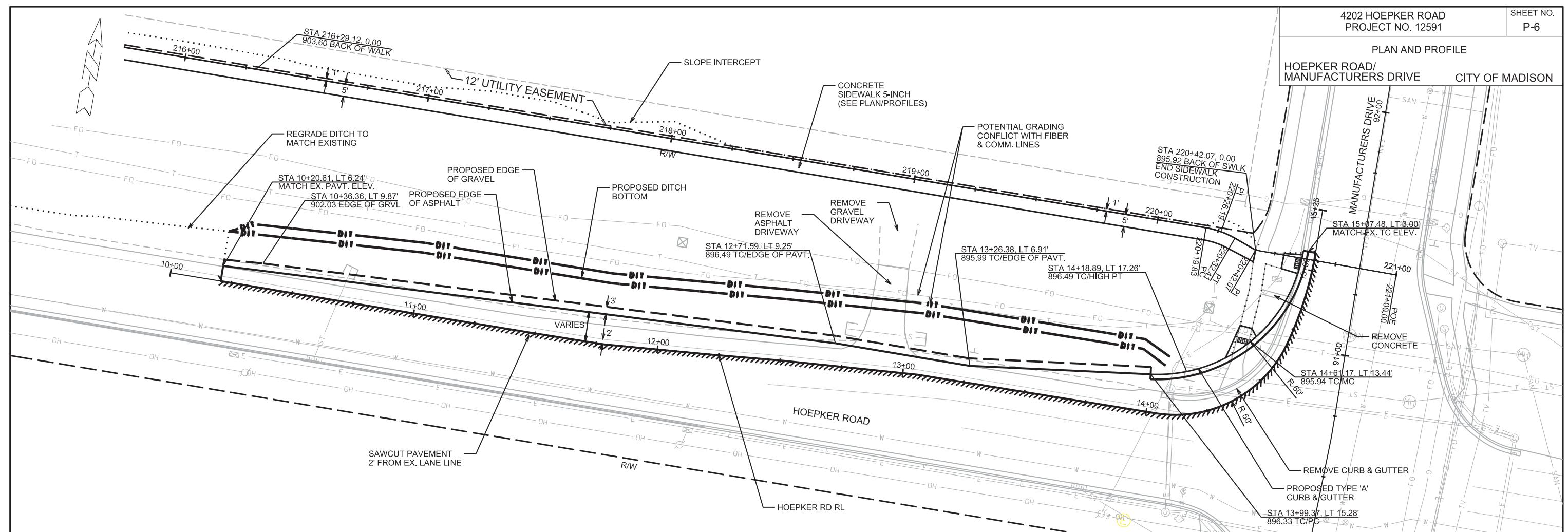

PLOT SCALE: \_\_\_\_\_  
PLOT NAME: \_\_\_\_\_  
REV. DATE: \_\_\_\_\_  
ORIGINATOR: CITY OF MADISON, STREETS DIVISION

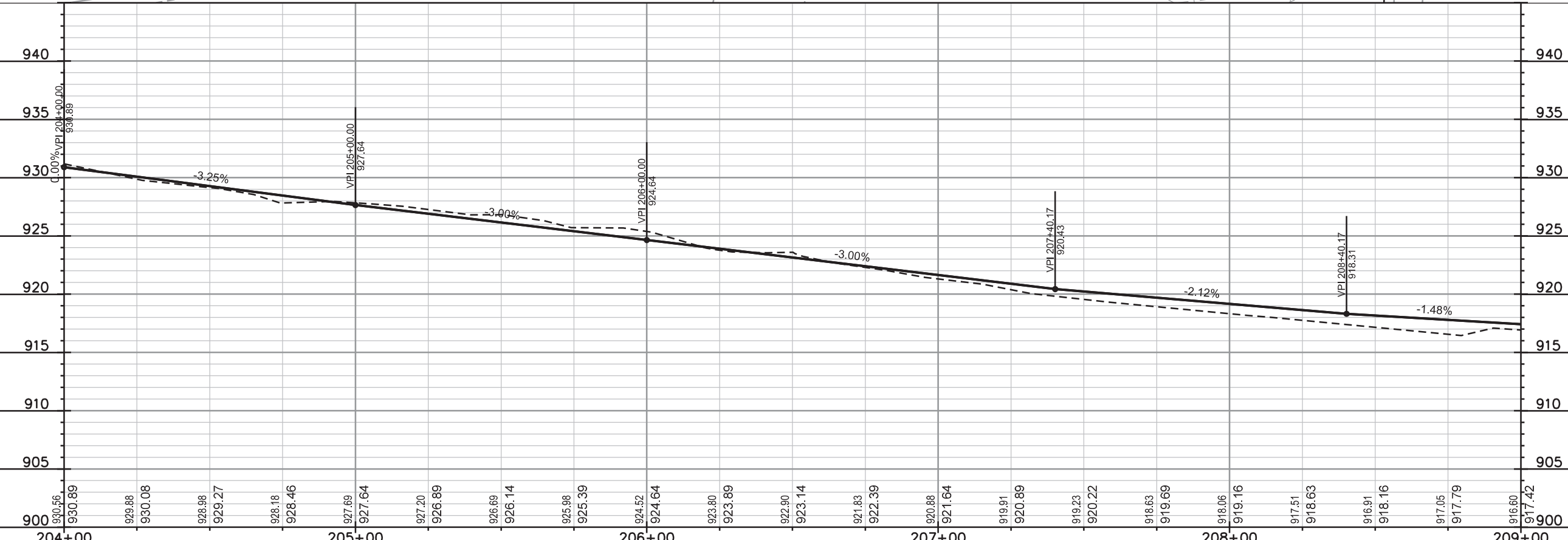
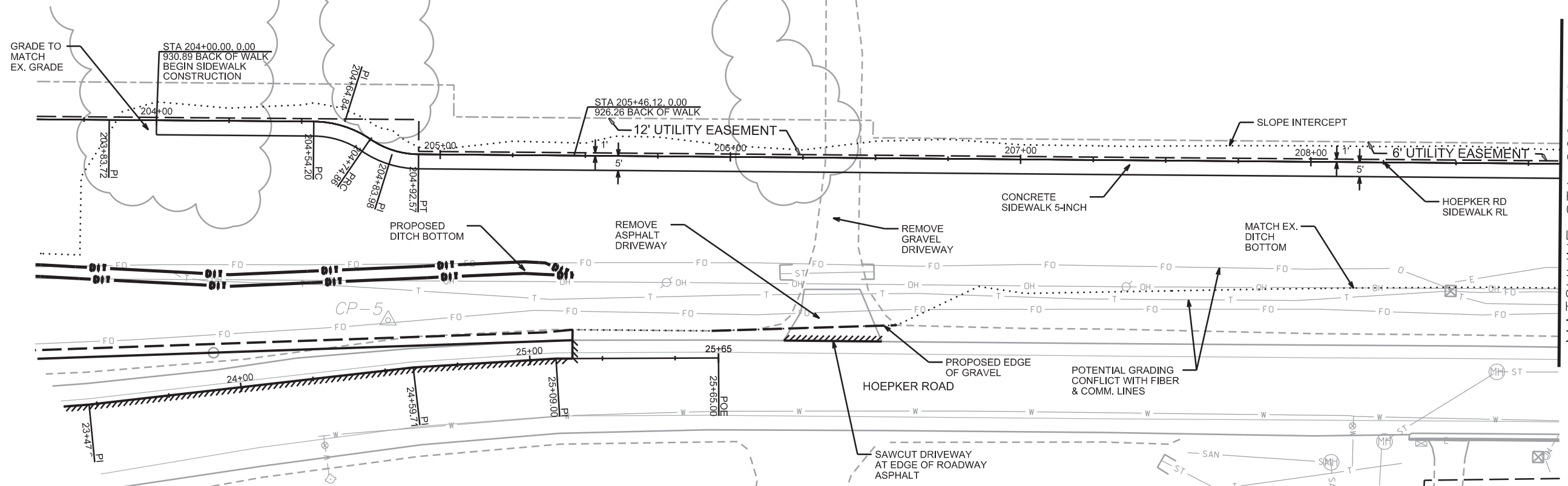

PLOT SCALE: \_\_\_\_\_

PLOT NAME: \_\_\_\_\_

REV. DATE: \_\_\_\_\_

ORIGINATOR: CITY OF MADISON, STREETS DIVISION

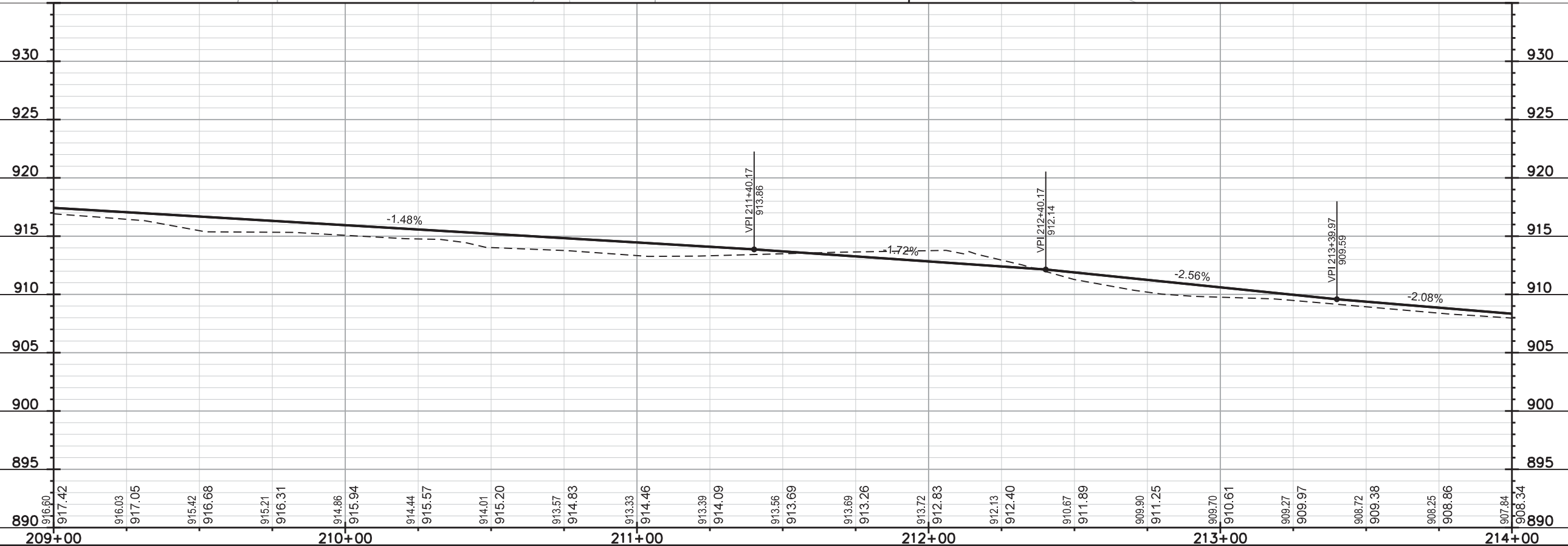
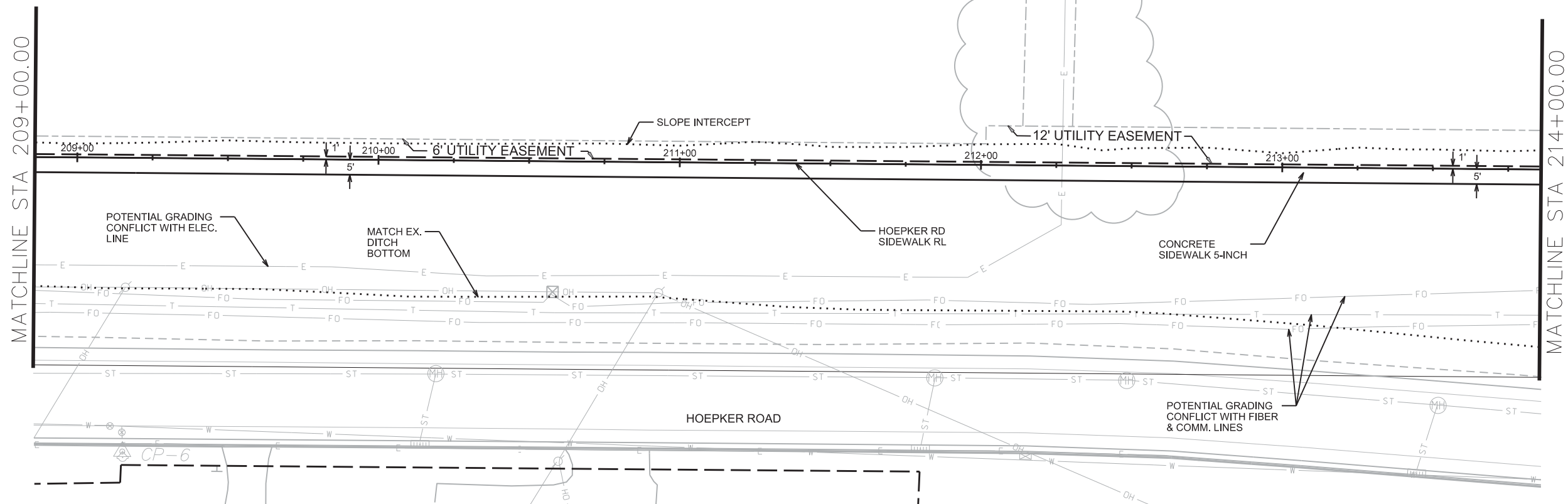

PLOT SCALE: \_\_\_\_\_

PLOT NAME: \_\_\_\_\_

REV. DATE: \_\_\_\_\_

ORIGINATOR: CITY OF MADISON, STREETS DIVISION

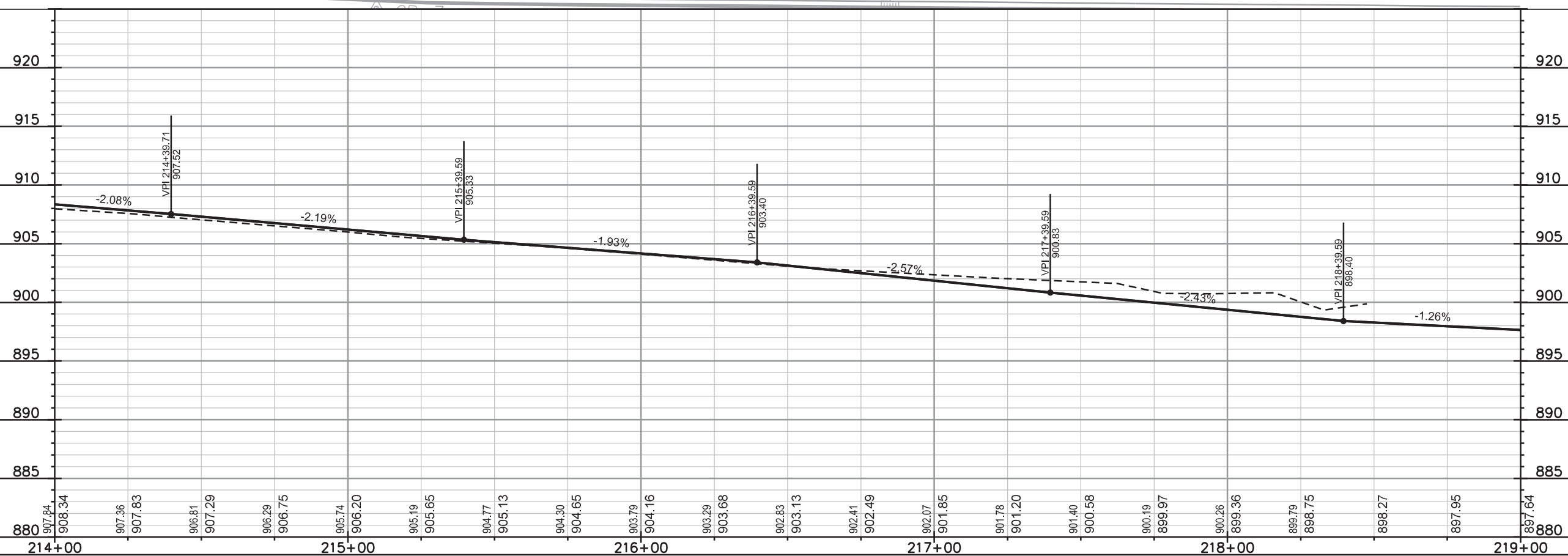
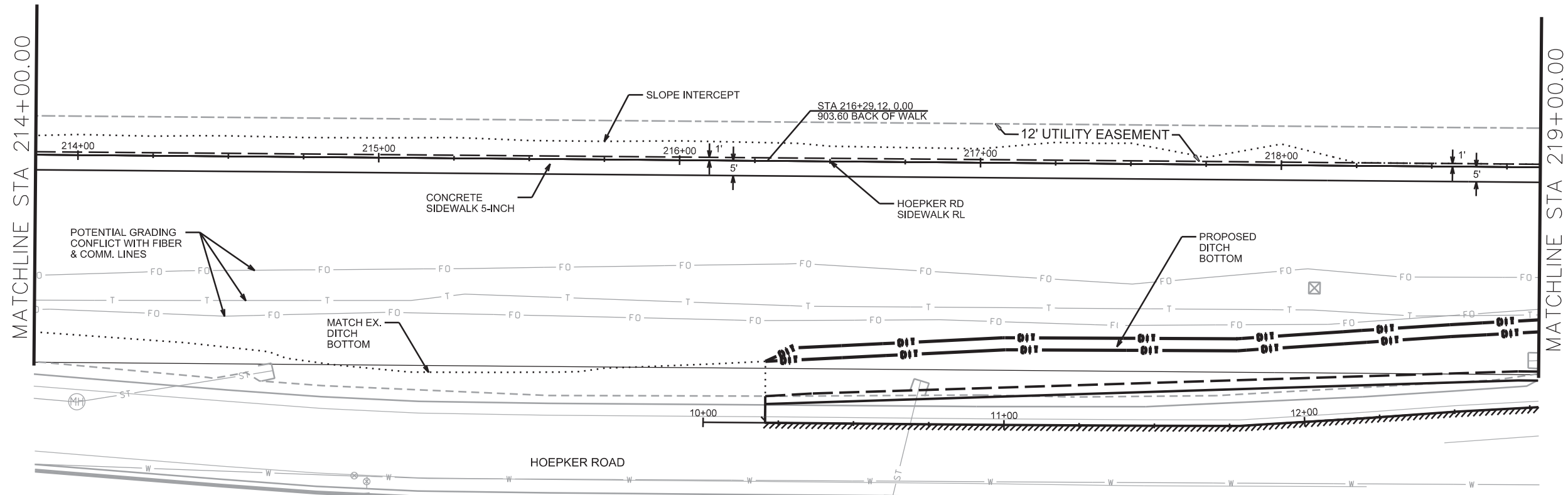

PLOT SCALE: \_\_\_\_\_

PLOT NAME: \_\_\_\_\_

REV. DATE: \_\_\_\_\_

ORIGINATOR: CITY OF MADISON, STREETS DIVISION

PLAN AND PROFILE  
HOEPKER ROAD SIDEWALK CITY OF MADISON

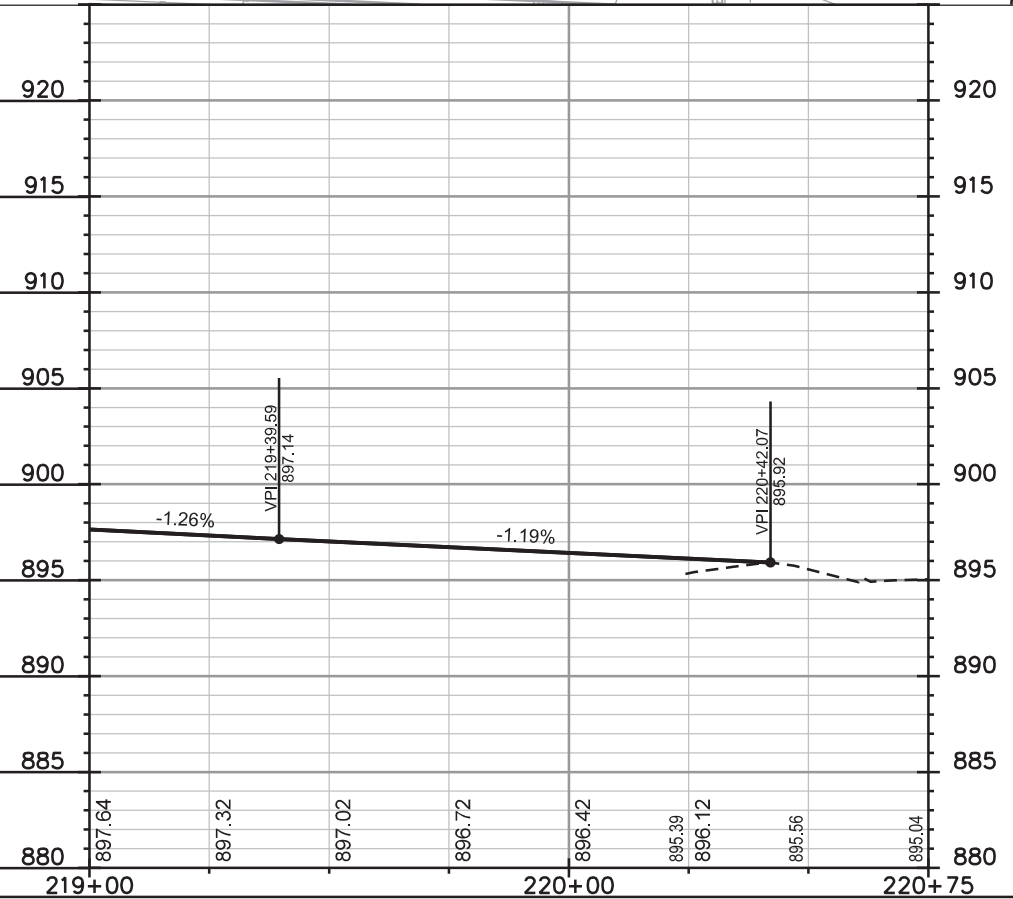
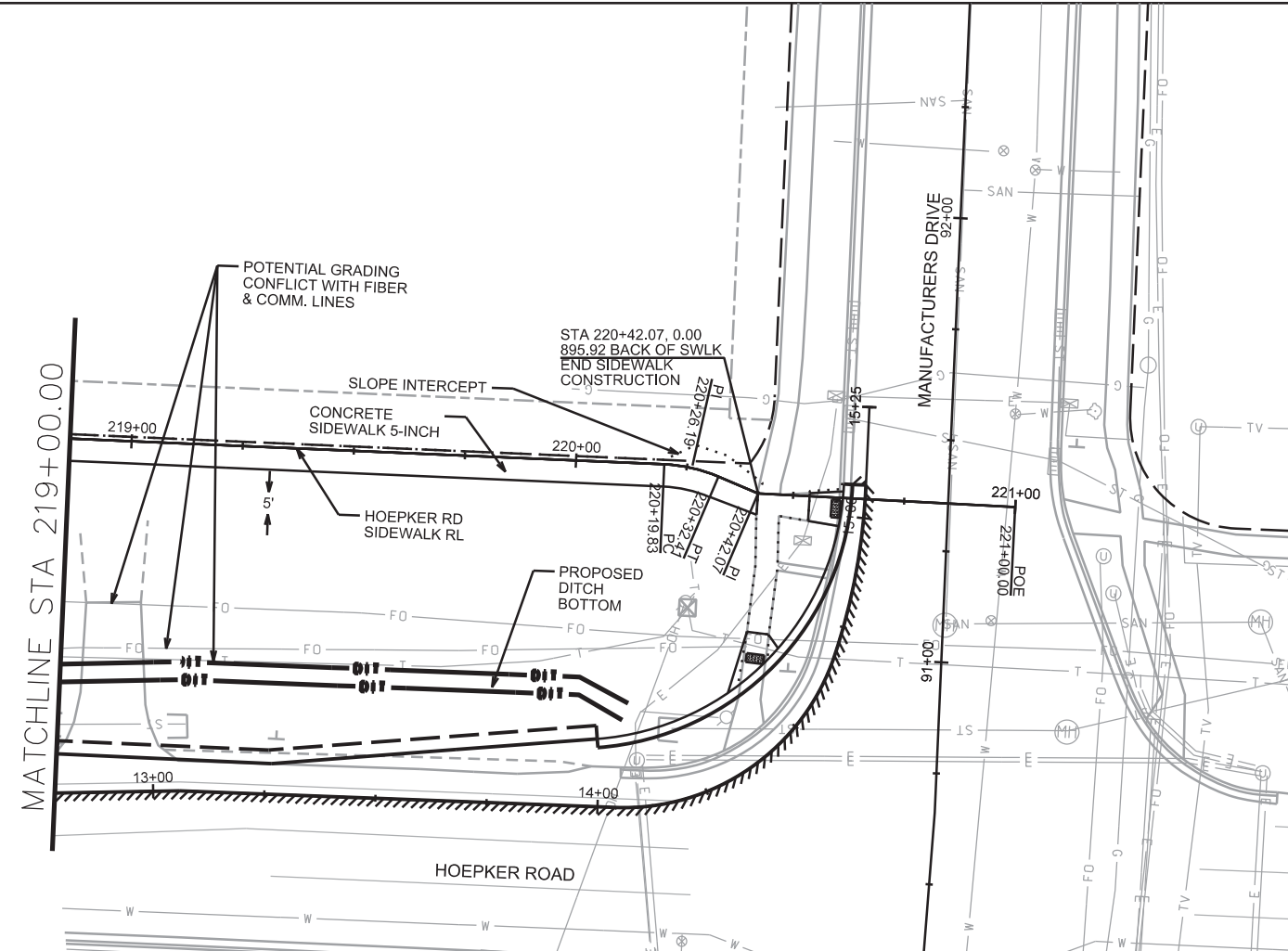

PLOT SCALE: \_\_\_\_\_

PLOT NAME: \_\_\_\_\_

REV. DATE: \_\_\_\_\_

ORIGINATOR: CITY OF MADISON, STREETS DIVISION

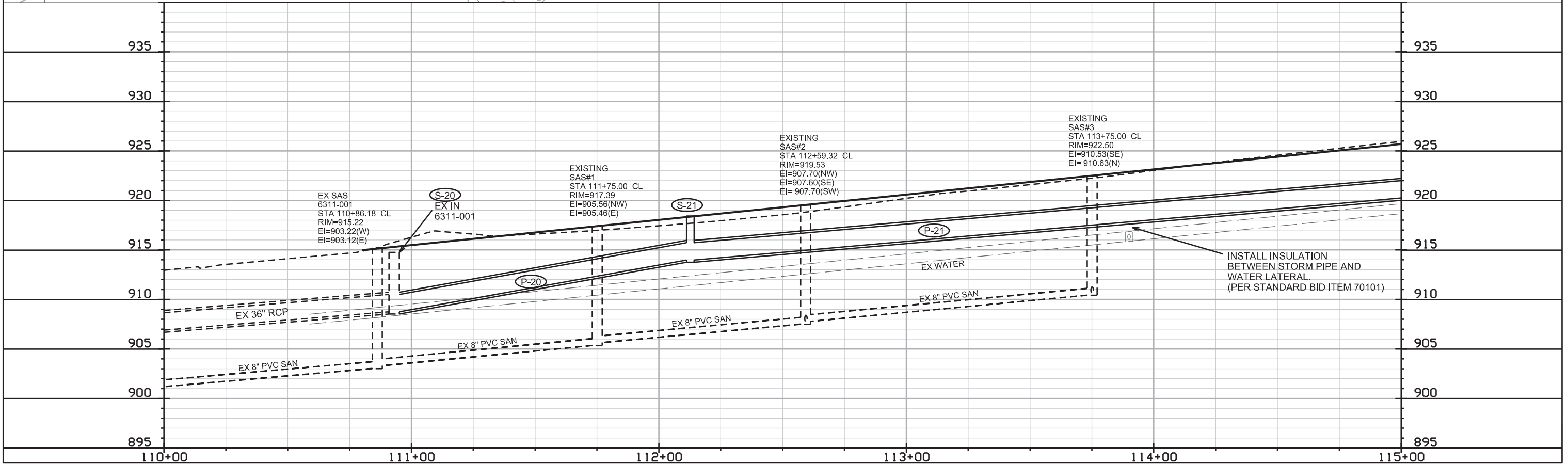
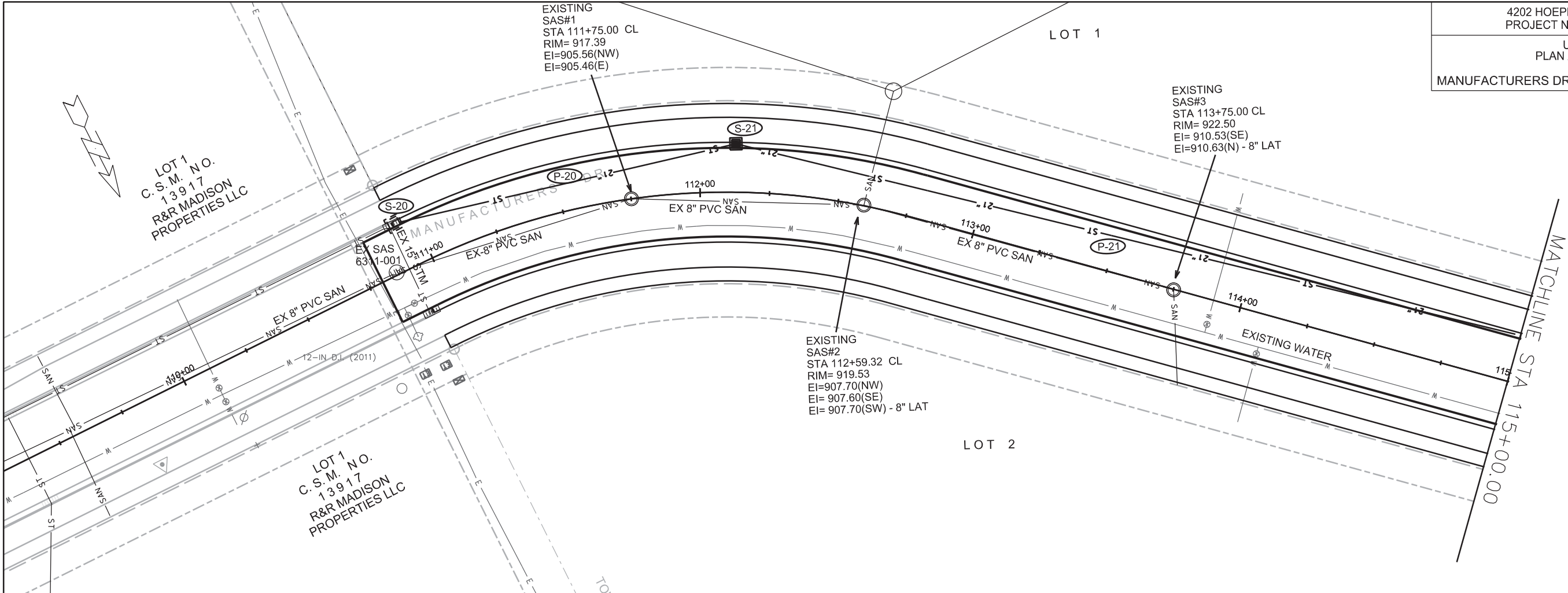

PLOT SCALE: \_\_\_\_\_

PLOT NAME: \_\_\_\_\_

REV. DATE: \_\_\_\_\_

ORIGINATOR: CITY OF MADISON, STREETS DIVISION

LOT 1  
C.S.M. No.  
7441  
CHARLES M JORGENSEN

LOT 1  
C.S.M. NO.  
4924  
SOUTH CENTRAL INDUSTRIAL  
PROPERTIES XVI LP

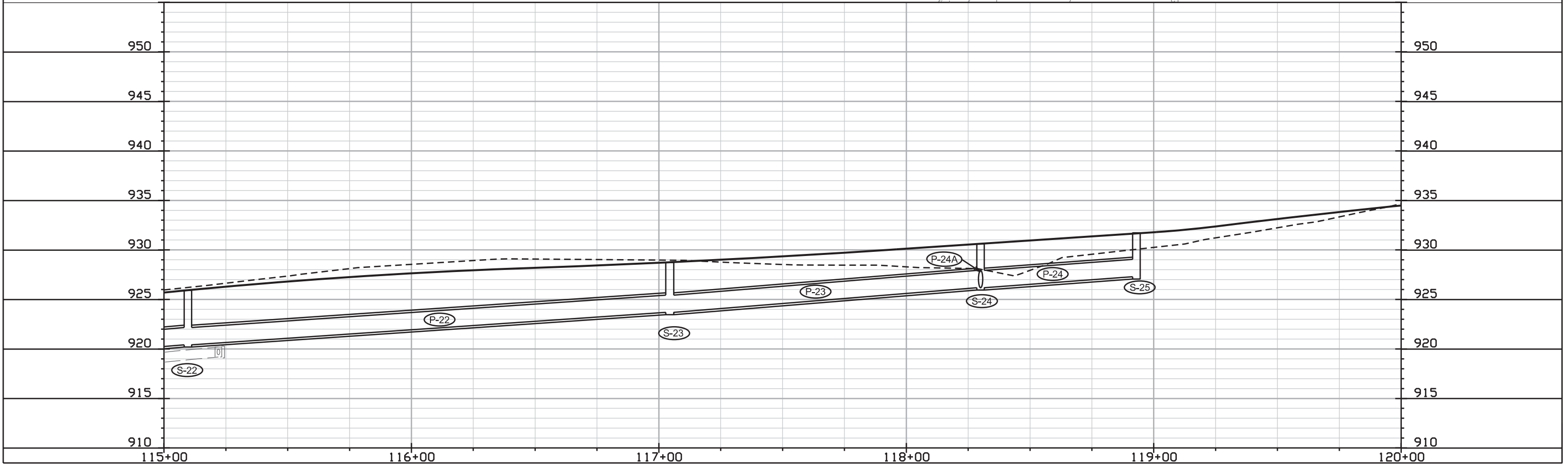
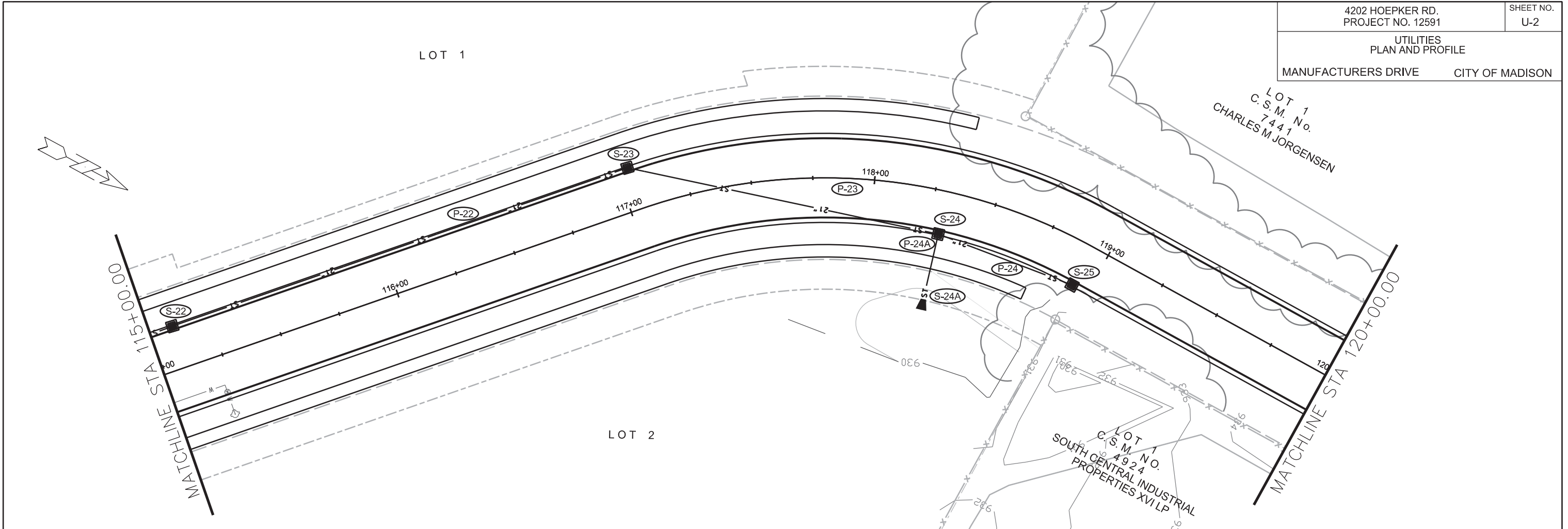

PLOT SCALE: \_\_\_\_\_  
PLOT NAME: \_\_\_\_\_  
REV. DATE: \_\_\_\_\_  
ORIGINATOR: CITY OF MADISON, STREETS DIVISION

REVISION 5/29/20 AJZ  
- Remove X's

4202 HOEPKER RD.  
PROJECT NO. 12951

SHEET NO.  
U-3

UTILITIES  
PLAN AND PROFILE  
MANUFACTURERS DRIVE CITY OF MADISON

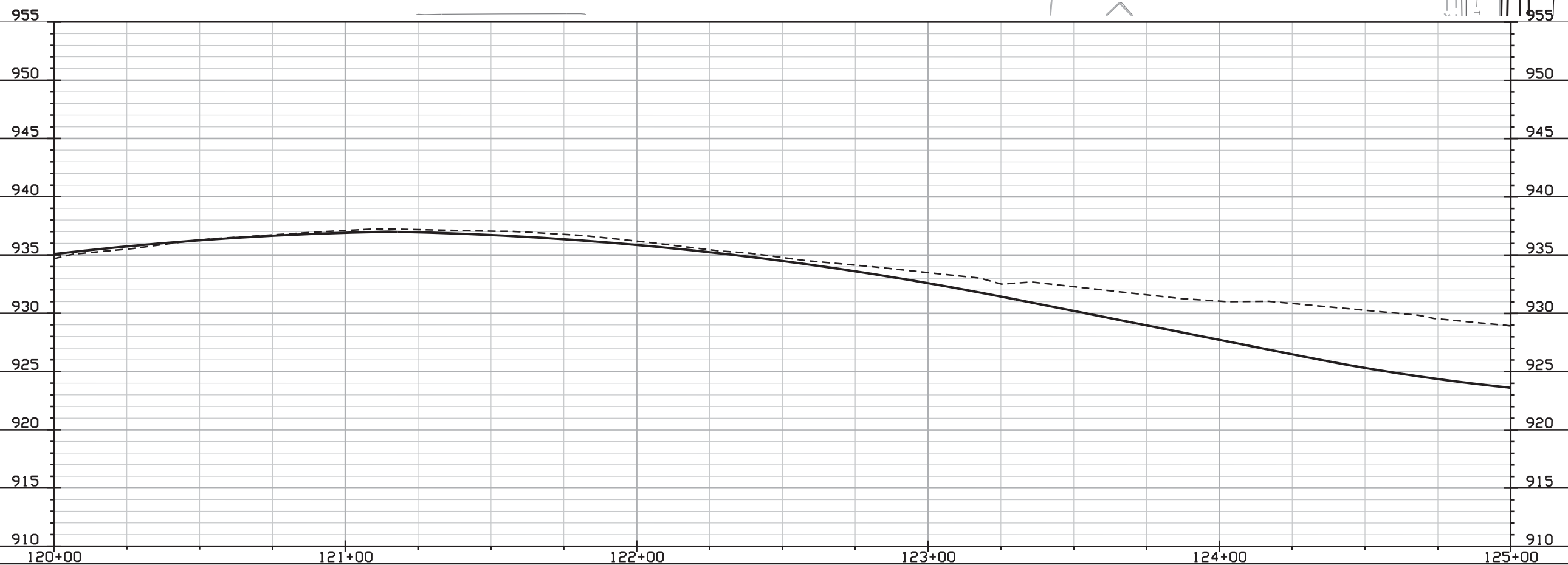
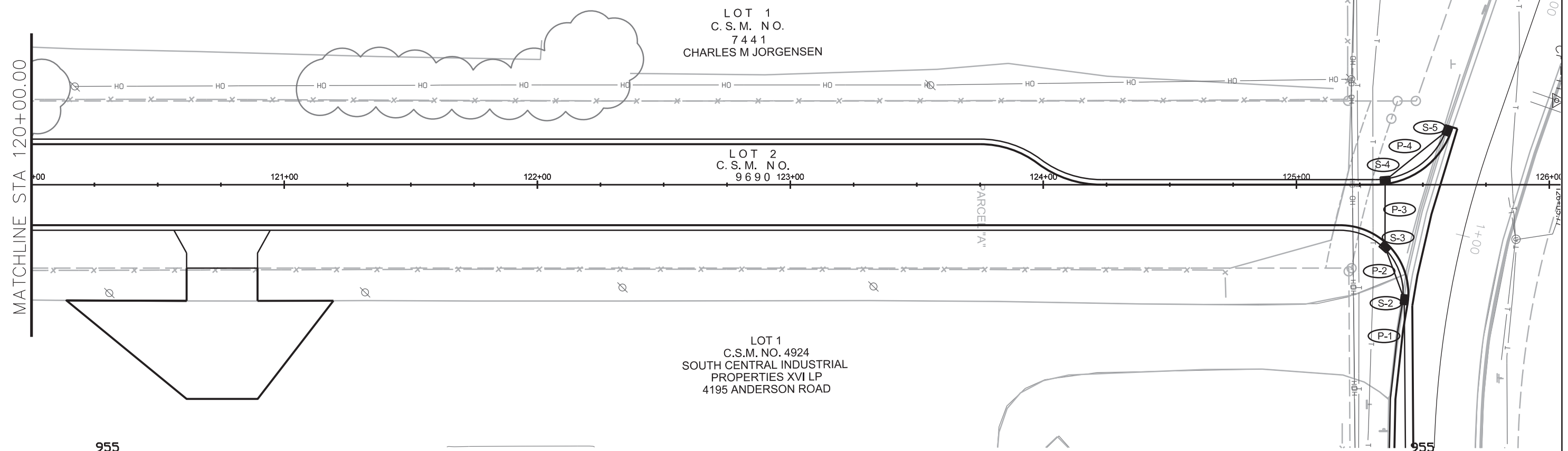
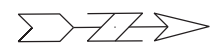

PLOT SCALE: \_\_\_\_\_

PLOT NAME: \_\_\_\_\_

REV. DATE: \_\_\_\_\_

ORIGINATOR: CITY OF MADISON, STREETS DIVISION



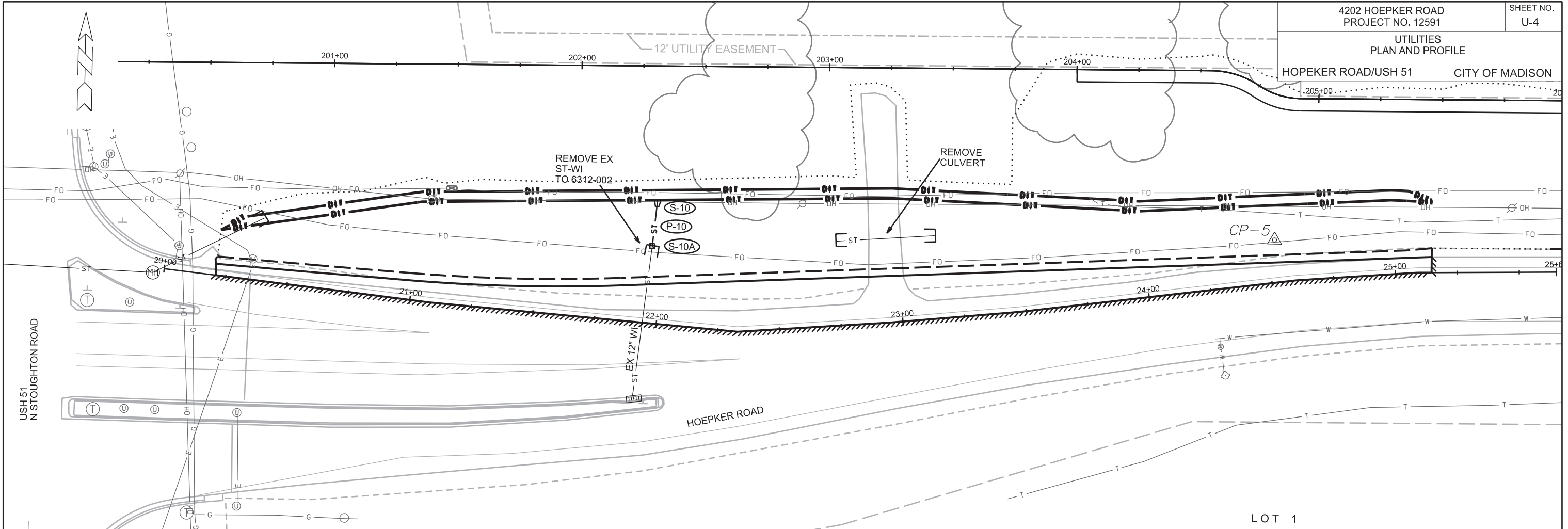

PLOT SCALE: \_\_\_\_\_

PLOT NAME: \_\_\_\_\_

REV. DATE: \_\_\_\_\_

ORIGINATOR: CITY OF MADISON, STREETS DIVISION

UTILITIES  
PLAN AND PROFILE  
HOEPKER ROAD/  
MANUFACTURERS DRIVE CITY OF MADISON

REVISION 6/19/20 EEA  
- Add trench patch call off

TRENCH PATCH TYPE III  
2" UPPER LAYER 4MT 58-28 S  
3" LOWER LAYER 3MT 58-28 S

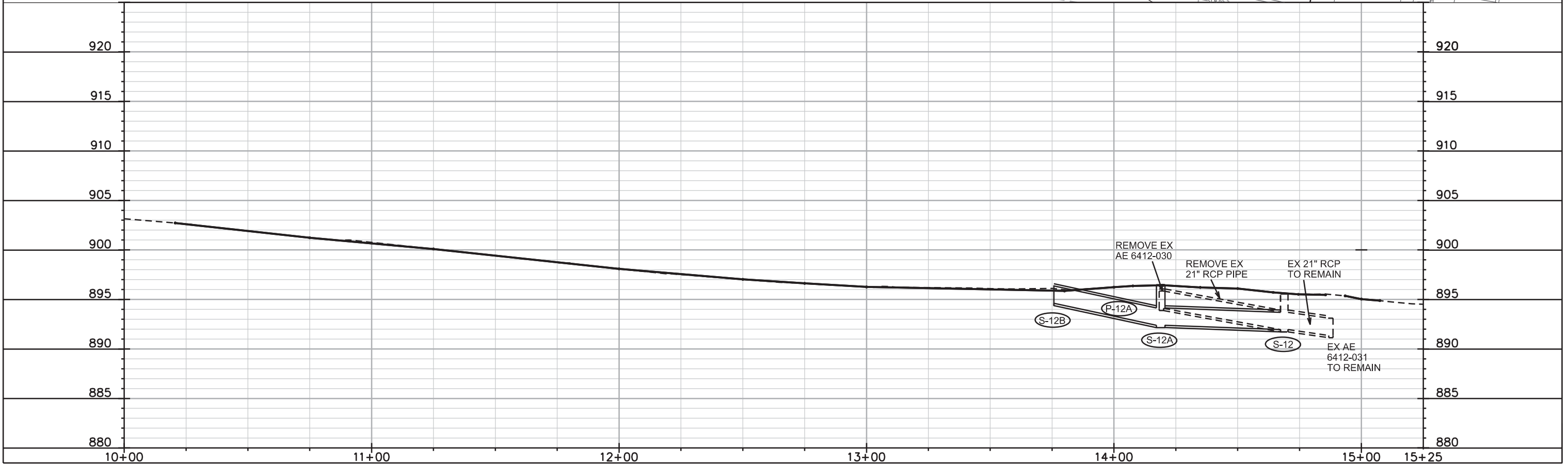
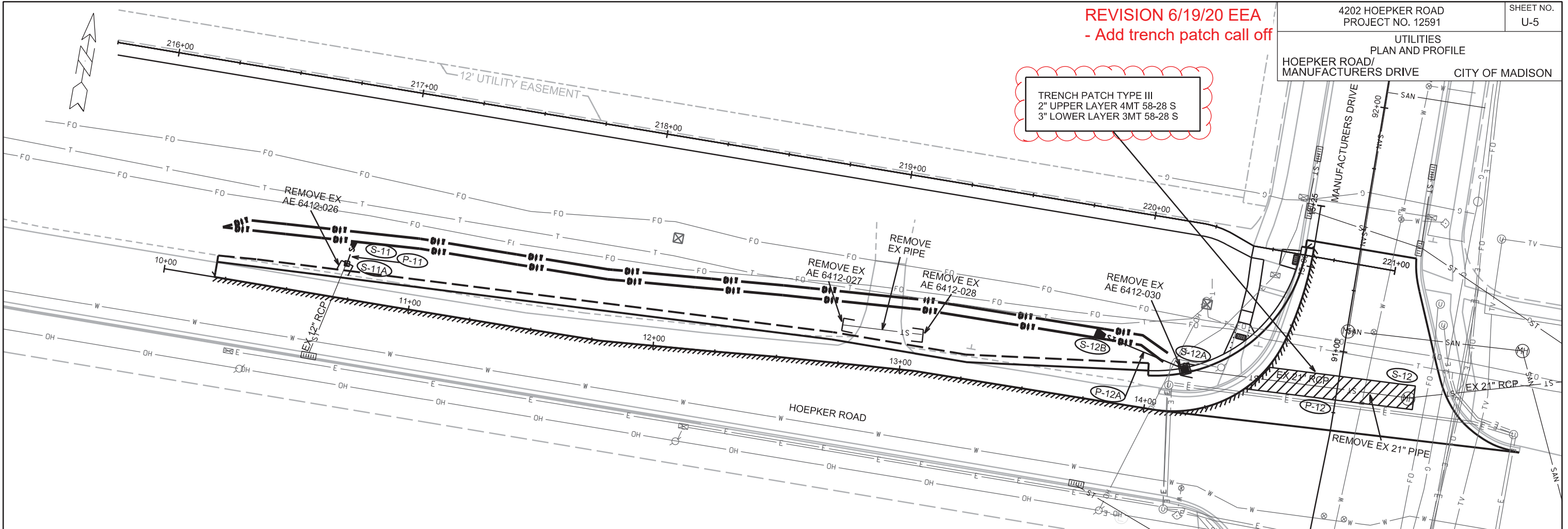

PLOT SCALE: \_\_\_\_\_

PLOT NAME: \_\_\_\_\_

REV. DATE: \_\_\_\_\_

ORIGINATOR: CITY OF MADISON, STREETS DIVISION

REVISED 5/ 21/ 2020 - EEA  
 -Upsized storm from 12" to 18"  
 - Added trench patch note

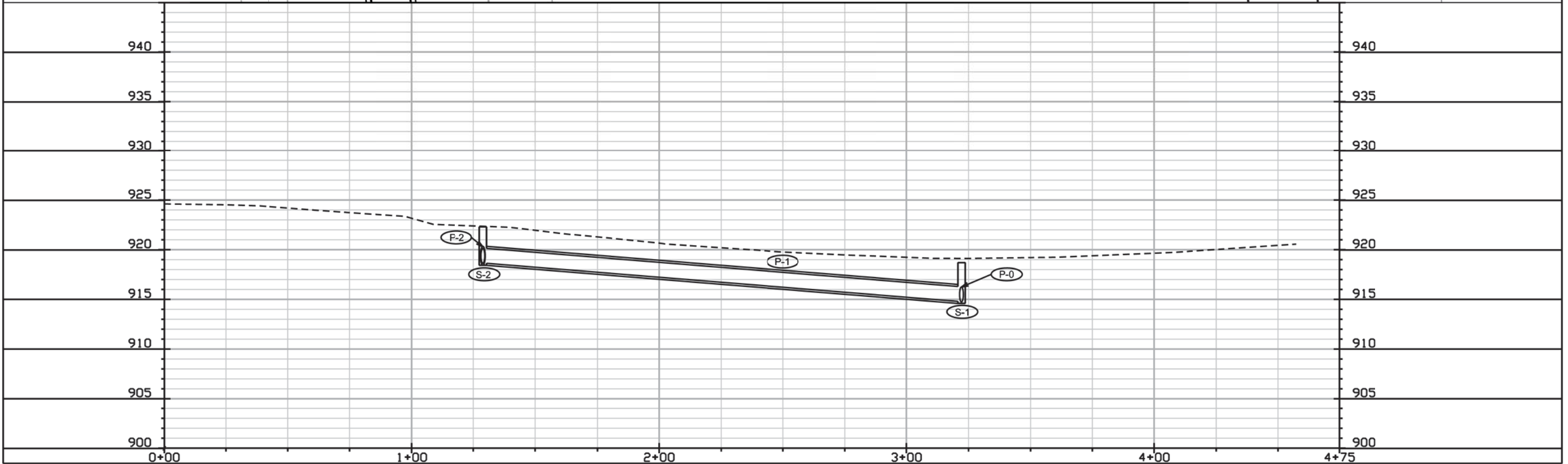
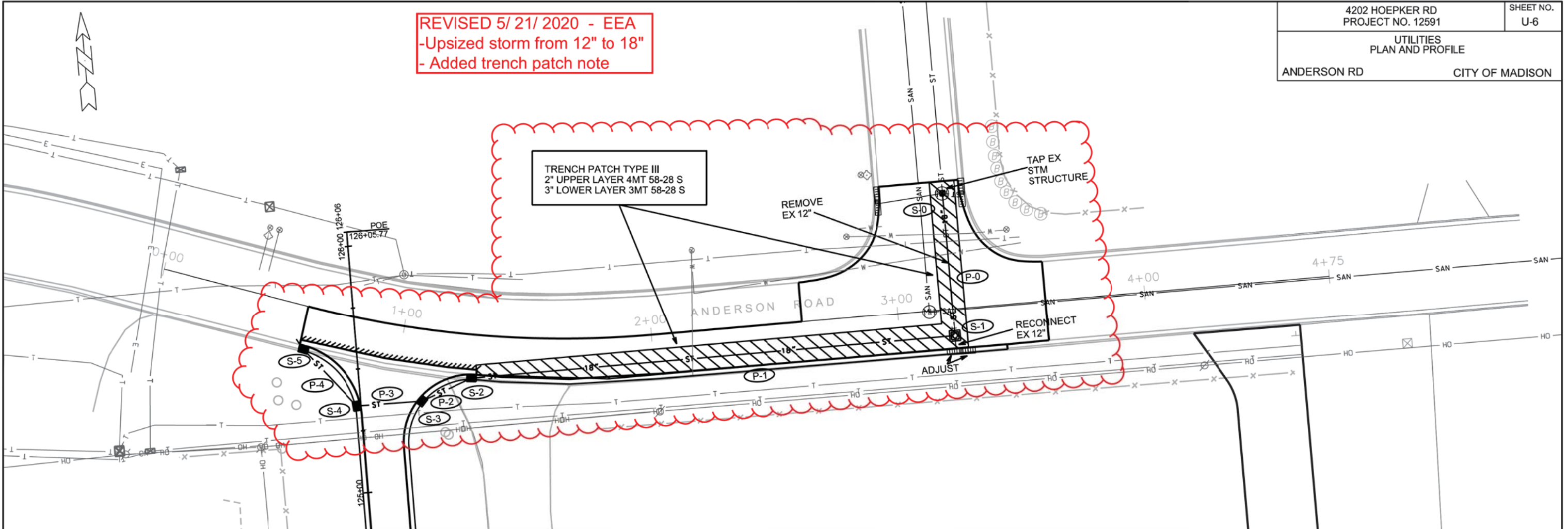

PLOT SCALE: \_\_\_\_\_  
 PLOT NAME: \_\_\_\_\_  
 REV. DATE: \_\_\_\_\_  
 ORIGINATOR: CITY OF MADISON, STREETS DIVISION

# STORM SEWER SCHEDULE

\* REVISED 5/21/2020 EEA

+ REVISED 6/12/20 EEA

^^ REVISED 6/17/20 EEA

4202 HOEPKER RD  
PROJECT NO. 12591

SHEET NO.  
U-STM

STORM SEWER SCHEDULE

CITY OF MADISON

## PROPOSED STORM STRUCTURES

STRUC. NO.	STATION	LOCATION (OFFSET)	TYPE	TOP OF CASTING	E.I.	DEPTH	NOTES
<b>ANDERSON ROAD</b>							
* S-1	3+22.22	RT-11.05	3X3 SAS	918.69	914.79	3.90	FP; W/ R-1550
* S-2	1+28.85	RT-17.58	H INLET	922.28	918.63	3.65	FP; W/ R-3067-7004-V
+* S-3	1+10.92	RT-28.98	H INLET	922.86	918.83	4.03	FP; W/ R-3067-7004-V
+* S-4	0+87.11	RT-35.20	H INLET	923.31	919.29	4.02	FP; LP; W/ R-3067-7004-VB
* S-5	0+62.66	RT-17.62	H INLET	924.03	920.38	3.65	FP; W/ R-3067-7004-V

## HOEPKER ROAD / USH 51

S-10	21+95.79	LT-49.97	12" RCP APRON END	-	931.39	-	W/ GATE
S-10A	21+95.45	LT-31.24	CONCRETE COLLAR	-	931.56	-	-

## HOEPKER ROAD / MANUFACTURERS DRIVE

S-11	10+73.98	LT-23.44	12" RCP APRON END	-	898.69	-	W/ GATE
S-11A	10+72.47	LT-14.20	CONCRETE COLLAR	-	899.06	-	-
S-12	14+68.84	RT-54.99	STORM TAP	-	891.95	-	TAP EX AS 6412-029
^^ S-12A	14+18.89	LT-16.76	3X3 SAS	896.49	892.39	4.10	FP; W/ R-3067-7004-V; (1)
S-12B	13+75.72	LT-27.20	21" RCP APRON END	-	894.61	-	W/ GATE

## MANUFACTURERS DRIVE

S-20	110+93.02	LT-17.50	EX IN 6311-002	-	908.75	-	CONNECT TO EX BOX OUT
S-21	112+12.73	LT-17.50	3X3 SAS	918.42	913.96	4.46	W/ R-3067-7004-V
S-22	115+09.64	LT-17.50	3X3 SAS	925.98	920.42	5.56	W/ R-3067-7004-V
S-23	117+04.42	LT-17.50	3X3 SAS	928.72	923.69	5.03	W/ R-3067-7004-V
S-24	118+30.02	RT-17.50	3X3 SAS	930.51	926.05	4.46	W/ R-3067-7004-V
S-24A	118+29.96	RT-48.90	21" RCP APRON END	-	928.75	-	W/ GATE
S-25	118+92.92	RT-17.50	3X3 SAS	931.73	927.27	4.46	-

## STORM STRUCTURE REMOVALS

ID NO.	STATION	LOCATION (OFFSET)	TYPE	NOTES
<b>HOEPKER ROAD</b>				
AE 6412-030	14+18.89	LT-16.76	21" RCP APRON END & GATE	-
AE 6412-027	12+75.33	LT-15.30	15" RCP APRON END & GATE	-
AE 6412-028	13+06.70	LT-15.03	15" RCP APRON END & GATE	-
AE 6412-026	10+72.47	LT-14.20	12" RCP APRON END & GATE	-
TO 6312-002	21+95.45	LT-31.24	12" RCP APRON END & GATE	-

## NOTES:

(1) BOX OUT TO N AT EI= 893.14 FOR FUTURE 12" PVT CONNECTION

## SPECIFIC NOTES:

-PLAN LENGTH (PAY LENGTH) IS FROM CENTER OF STRUCTURE TO CENTER OF STRUCTURE. PIPE LENGTH IS ACTUAL LENGTH OF PIPE FROM STRUCTURE WALL TO STRUCTURE WALL. SLOPE CALCULATED USING PIPE LENGTH.

-KOR N SEAL BOOTS OR EQUIVALENT SHALL BE USED FOR ALL PIPE CONNECTIONS TO INLETS. IN ADDITION, KOR N SEAL BOOTS SHALL BE REQUIRED FOR ANY TYPE II PIPE CONNECTIONS TO SAS STORM STRUCTURES. CONCRETE COLLARS OR KOR N SEAL MAY BE USED FOR ANY RCP OR HERCP CONNECTIONS TO SAS STORM STRUCTURES.

-ALL REBAR FOR FIELD POURED STRUCTURES SHALL BE EPOXY COATED. ANY EXPOSED STEEL SHALL BE TOUCHED UP OR RECOATED PRIOR TO USE.

-ALL FIELD POURED SAS STORM STRUCTURES SHALL BE CONSTRUCTED IN ACCORDANCE WITH STANDARD DETAIL DRAWING 5.7.3. ALL PRECAST SAS STORM STRUCTURES SHALL BE CONSTRUCTED IN ACCORDANCE WITH STANDARD DETAIL DRAWING 5.7.5.

## PROPOSED STORM PIPES

PIPE NO.	FROM (DNSTM)	TO (UPSTM)	DISCH. E.I.	INLET E.I.	PLAN (PAY) LGTH (FT)	PIPE LGTH (FT)	SLOPE (%)	PIPE SIZE	TYPE	NOTES
* P-0	TAP EX STM	S-1	914.50	914.79	58	57	0.51%	18"	TYPE I	-
* P-1	S-1	S-2	914.79	918.63	196	193	1.99%	18"	TYPE I	-
* P-2	S-2	S-3	918.63	918.83	22	19	1.05%	18"	TYPE I	-
* P-3	S-3	S-4	918.83	919.29	26	24	1.92%	18"	TYPE I	-
* P-4	S-4	S-5	919.29	920.38	31	28	3.89%	18"	TYPE I	-

P-10	S-10	S-10A	931.39	931.56	19	19	0.89%	12"	TYPE I	-
P-11	S-11	S-11A	898.69	899.06	9	9	4.11%	12"	TYPE I	-
P-12	S-12	S-12A	891.95	892.39	91	88	0.50%	21"	TYPE I	-
P-12A	S-12A	S-12B	892.39	894.61	39	37	6.00%	21"	TYPE I	-
P-20	S-20	S-21	908.75	913.96	127	123	4.24%	21"	TYPE I	-
P-21	S-21	S-22	913.96	920.42	301	298	2.17%	21"	TYPE I	-
P-22	S-22	S-23	920.42	923.69	195	192	1.70%	21"	TYPE I	-
P-23	S-23	S-24	923.69	926.05	128	125	1.89%	21"	TYPE I	-
P-24	S-24	S-25	926.05	927.27	58	55	2.22%	21"	TYPE I	-
P-24A	S-24	S-24A	926.05	928.75	31	30	9.00%	21"	TYPE I	-

## STORM PIPE REMOVALS

REMOVE FROM	REMOVE TO	LENGTH (FT)	PIPE SIZE	PIPE TYPE	NOTES
<b>HOEPKER ROAD</b>					
S-12	AE 6412-030	91	21"	RCP	-
AE 6412-027	AE 6412-028	32	15"	CULVERT	-
22+74.84 LT-34.16	23+15.90 LT-33.58	40	24"	CULVERT	-

## ANDERSON ROAD

* S-0	S-1	58	12"	-	-
-------	-----	----	-----	---	---

- ABBREVIATIONS: AE = APRON ENDWALL; RCP = REINFORCED CONCRETE PIPE; HERCP = HORIZONTAL ELLIPTICAL REINFORCED CONCRETE PIPE; DNA = DOES NOT APPLY; SAS = SEWER ACCESS STRUCTURE; LP = LOW POINT INLET STRUCTURE; FP = FIELD POURED STRUCTURE; TR = TOP OF CONCRETE ROOF; NCM = NO CROWN MATCH FOR PIPES; UD = UNDERDRAIN

- APPROXIMATE DISCHARGE E.I. GIVEN, ADJUST E.I. AND PIPE SLOPE IN THE FIELD.

- TOP OF CASTING GRADE GIVEN IS THE TOP OF CURB FOR INLET STRUCTURES AND THE FLOWLINE OF THE CLOSED CASTING FOR SAS'S.

- ALL REINFORCED CONCRETE PIPES TO BE CLASS III UNLESS OTHERWISE NOTED.

- SURVEYOR TO CONFIRM THAT ALL INLET STATION / OFFSETS LINE UP WITH PROPOSED CURB AND GUTTER.

- ALL STRUCTURES CALLED OUT AS FIELD POURED SHALL BE FIELD POURED. ALL OTHER STRUCTURES (NOT INDICATED AS FIELD POURED) SHALL BE SUBMITTED TO CITY ENGINEERING FOR APPROVAL IF PRECAST STRUCTURES ARE PREFERRED. CONTACT ELIA E. ACOSTA OF CITY ENGINEERING AT (608) 266-4096 FOR PRECAST APPROVALS, FAX SHOP DRAWINGS TO (608)264-9275, OR EMAIL SHOP DRAWINGS TO EACOSTA@CITYOFMADISON.COM.

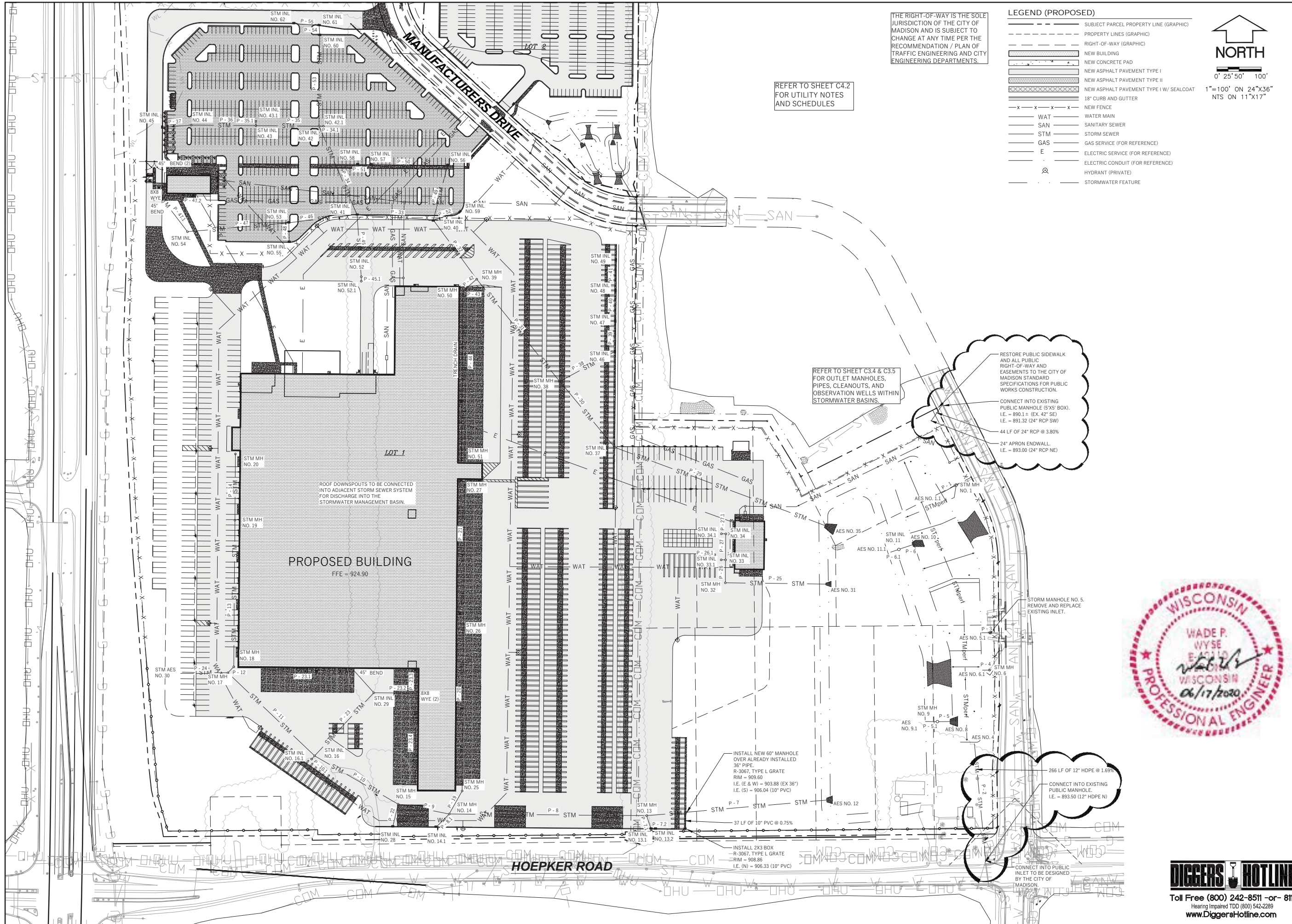

THE RIGHT-OF-WAY IS THE SOLE JURISDICTION OF THE CITY OF MADISON AND IS SUBJECT TO CHANGE AT ANY TIME PER THE RECOMMENDATION / PLAN OF TRAFFIC ENGINEERING AND CITY ENGINEERING DEPARTMENTS.

REFER TO SHEET C4.2 FOR UTILITY NOTES AND SCHEDULES

REFER TO SHEET C3.4 & C3.5 FOR OUTLET MANHOLES, PIPES, CLEANOUTS, AND OBSERVATION WELLS WITHIN STORMWATER BASINS.

RESTORE PUBLIC SIDEWALK AND ALL PUBLIC RIGHT-OF-WAY AND EASEMENTS TO THE CITY OF MADISON STANDARD SPECIFICATIONS FOR PUBLIC WORKS CONSTRUCTION.  
 CONNECT INTO EXISTING PUBLIC MANHOLE (5'x5' BOX).  
 I.E. = 890.1 ± (EX. 42" SE)  
 I.E. = 891.32 (24" RCP SW)  
 44 LF OF 24" RCP @ 3.80%  
 24" APRON ENDWALL.  
 I.E. = 893.00 (24" RCP NE)



- LEGEND (PROPOSED)**
- SUBJECT PARCEL PROPERTY LINE (GRAPHIC)
  - PROPERTY LINES (GRAPHIC)
  - RIGHT-OF-WAY (GRAPHIC)
  - NEW BUILDING
  - NEW CONCRETE PAD
  - NEW ASPHALT PAVEMENT TYPE I
  - NEW ASPHALT PAVEMENT TYPE II
  - NEW ASPHALT PAVEMENT TYPE I W/ SEALCOAT
  - 18" CURB AND GUTTER
  - NEW FENCE
  - WAT WATER MAIN
  - SAN SANITARY SEWER
  - STM STORM SEWER
  - GAS GAS SERVICE (FOR REFERENCE)
  - E ELECTRIC SERVICE (FOR REFERENCE)
  - ELECTRIC CONDUIT (FOR REFERENCE)
  - HYDRANT (PRIVATE)
  - STORMWATER FEATURE

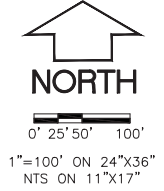

ROOF DOWNSPOUTS TO BE CONNECTED INTO ADJACENT STORM SEWER SYSTEM FOR DISCHARGE INTO THE STORMWATER MANAGEMENT BASIN.

INSTALL NEW 60" MANHOLE OVER ALREADY INSTALLED 36" PIPE.  
 R-3067, TYPE L GRATE  
 RIM = 909.60  
 I.E. (E & W) = 903.88 (EX 36")  
 I.E. (S) = 905.04 (10" PVC)

266 LF OF 12" HDPE @ 1.69%  
 CONNECT INTO EXISTING PUBLIC MANHOLE.  
 I.E. = 893.50 (12" HDPE N)

CONNECT INTO PUBLIC INLET TO BE DESIGNED BY THE CITY OF MADISON.

**RUEDEBUSCH DEVELOPMENT & CONSTRUCTION**  
 DEVELOPMENT • CONSTRUCTION • BROKERAGE • CONSULTING  
 4605 DOVETAIL DRIVE MADISON, WI 53704  
 PHONE 608.249.2012 FAX 608.249.2032

**WYSER ENGINEERING**  
 608.843.3388  
 www.wyserengineering.com

INDUSTRIAL DEVELOPMENT - CITY OF MADISON  
 MANUFACTURERS DRIVE  
 MADISON, WISCONSIN

DATE:	06.22.20
NO.	
REVISION:	STORM ROOF DRAIN UPDATE

SHEET TITLE:	UTILITY PLAN - STORM CONNECTION TO PUBLIC SYSTEM
JOB NUMBER:	Project Number
DESIGNED BY:	DOS
DRAWN BY:	DOS
CHECKED BY:	WFW
DATE:	06.15.19
SHEET NO.:	

**C4.1A**

**DIGGERS HOTLINE**  
 Toll Free (800) 242-8511 or 811  
 Hearing Impaired TDD (800) 542-2289  
 www.DiggersHotline.com

REVISION 5/29/20 AJZ  
- Remove X's

4202 HOEPKER RD.  
PROJECT NO. 12591

SHEET NO.  
M-1

PAVEMENT MARKING PLAN

ANDERSON - MANUFACTURERS

CITY OF MADISON



Anderson Road

Manufacturers Drive

Install 24" Stop Bar Epoxy



PLOT SCALE:

PLOT NAME:

REV. DATE:

ORIGINATOR: CITY OF MADISON, TRAFFIC ENG. DIV.



Manufacturers Drive

Install 8" White Epoxy

Install 4" Double Yellow Epoxy



Install Left Turn/Through Symbol Epoxy

Install Right Turn Symbol Epoxy

Install 24" Stop Bar Epoxy

Install 4" White Edgeline Epoxy

Install 6" Crosswalk Epoxy

Match to Existing

Install 4" Double Yellow Epoxy

250'

11'

45'

Match to Existing

Remove 24" Stop Bar

55'

Remove 10' Line X 30' Gap Remove 4" Double Yellow

Install 8" White Epoxy

Match to Existing

Hoepker Road

Install Right Turn/Through Symbol Epoxy

PLOT SCALE:  
PLOT NAME:  
REV. DATE:  
ORIGINATOR: CITY OF MADISON, TRAFFIC ENG. DIV.

REVISION 5/29/20 AJZ  
- Remove X's



Dimension taken from FOC

Haase Road

Install Right Turn Symbol Epoxy

Install Word Only Epoxy

Match to Existing

N. Stoughton Road/USH 51

Anderson Road

105'

14'

ONLY

ONLY

PLOT SCALE:

PLOT NAME:

REV. DATE:

ORIGINATOR: CITY OF MADISON, TRAFFIC ENG. DIV.



PLOT SCALE:

PLOT NAME:

REV. DATE:

ORIGINATOR: CITY OF MADISON, TRAFFIC ENG. DIV.

N. Stoughton Road/USH 51

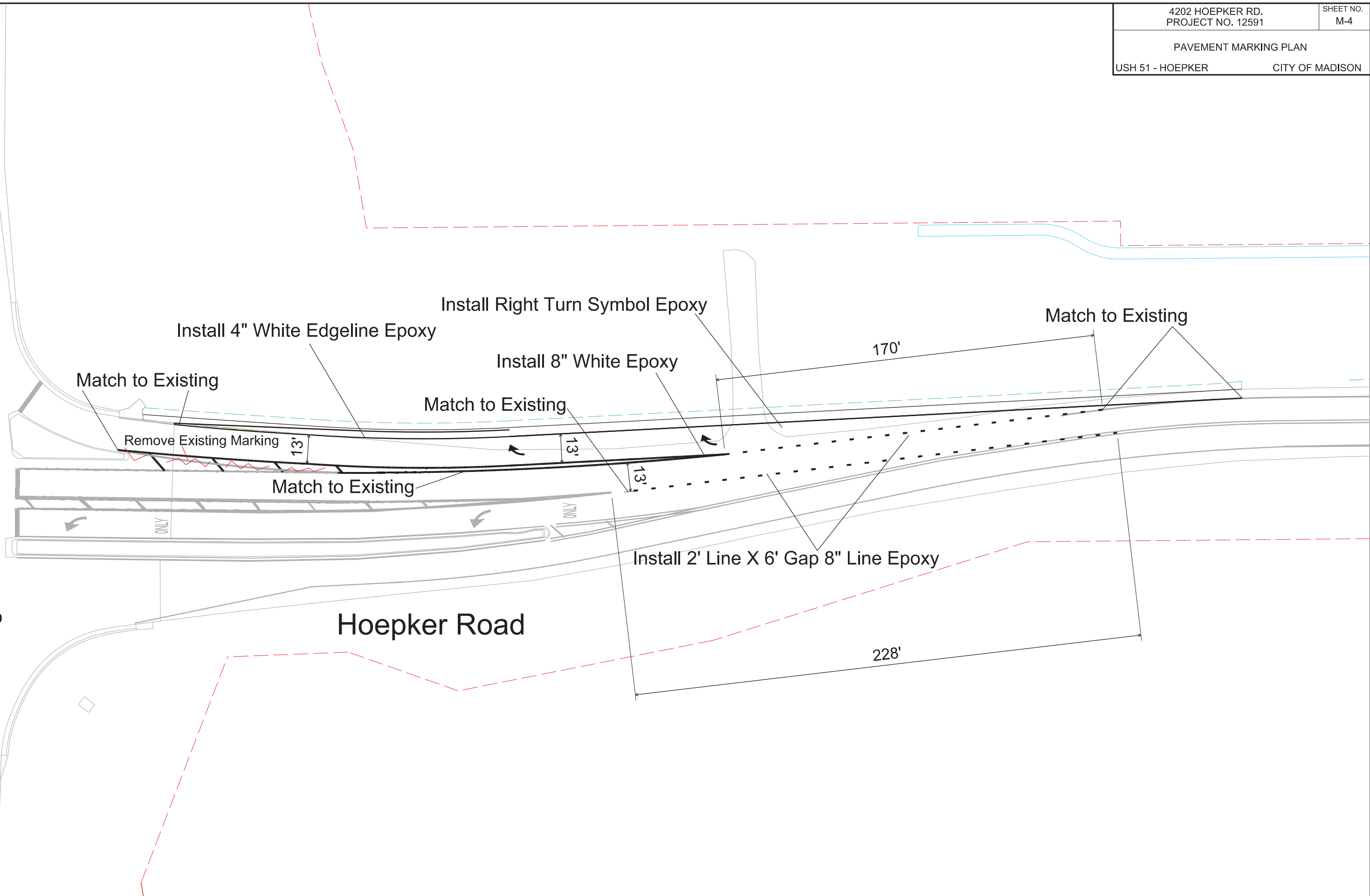

Install 4" White Edgeline Epoxy

Install Right Turn Symbol Epoxy

Match to Existing

Match to Existing

Install 8" White Epoxy

170'

Remove Existing Marking

Match to Existing

Match to Existing

Install 2' Line X 6' Gap 8" Line Epoxy

Hoepker Road

228'

CROSS SECTIONS  
MANUFACTURERS DRIVE CITY OF MADISON

PLOT SCALE: \_\_\_\_\_

PLOT NAME: \_\_\_\_\_

REV. DATE: \_\_\_\_\_

ORIGINATOR: CITY OF MADISON STREETS DIVISION

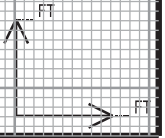
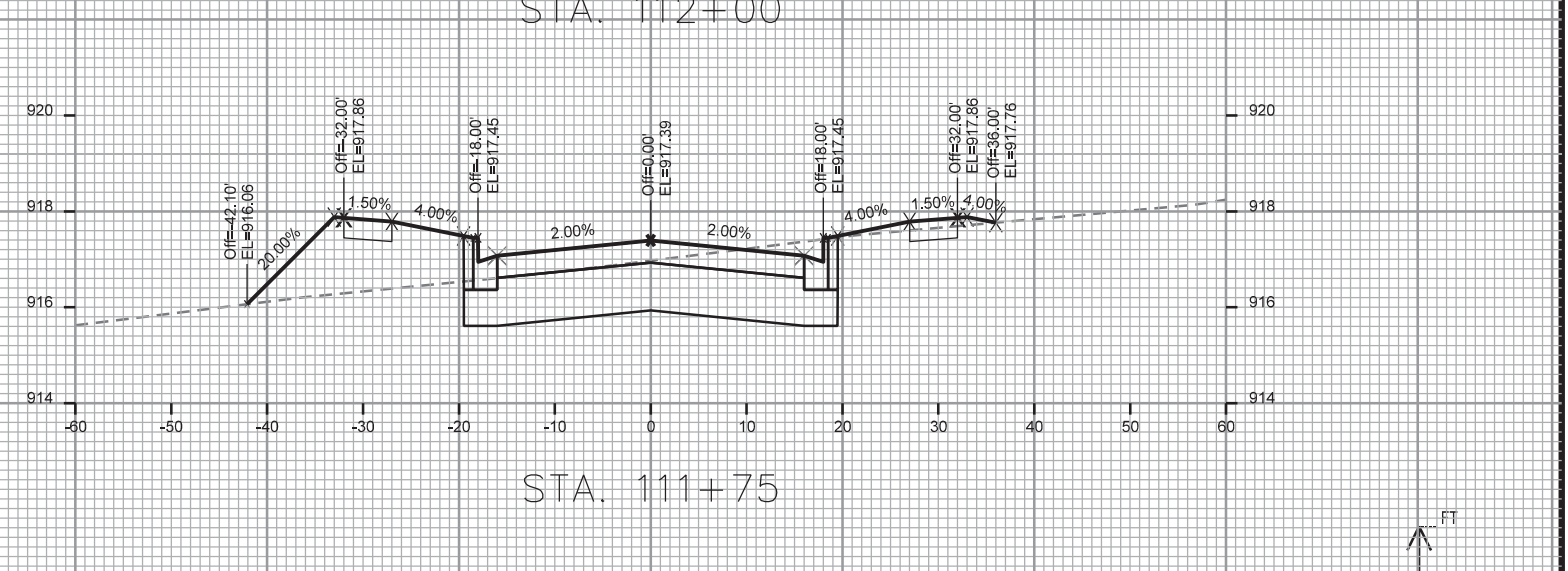
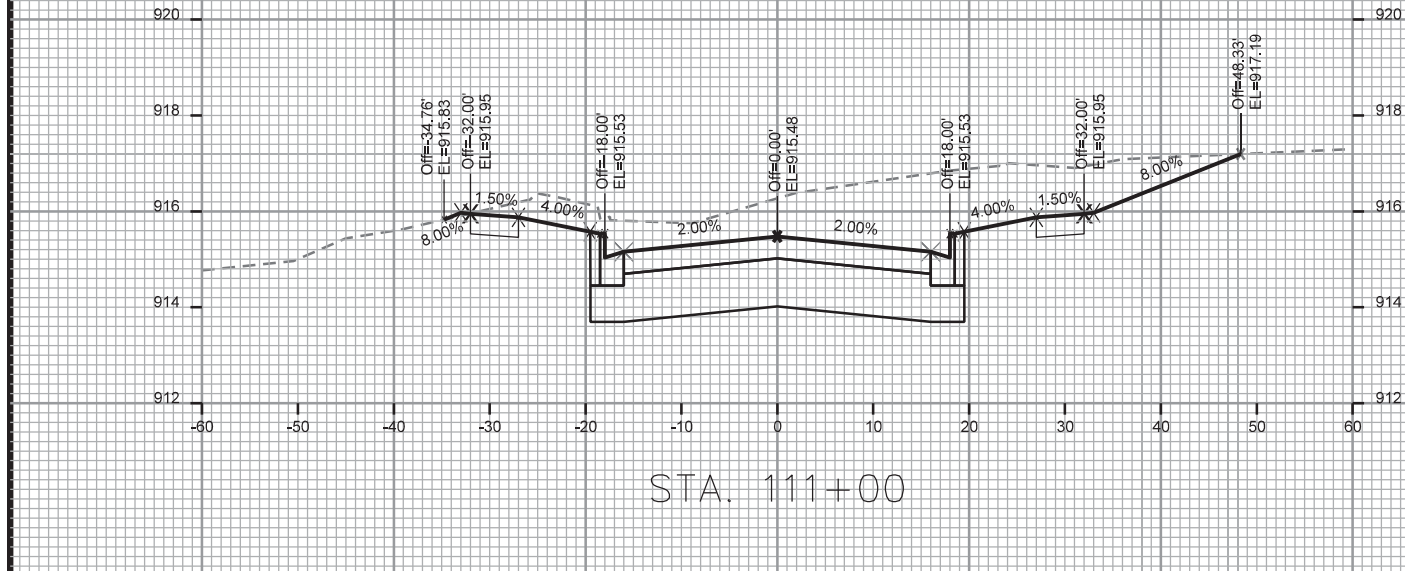
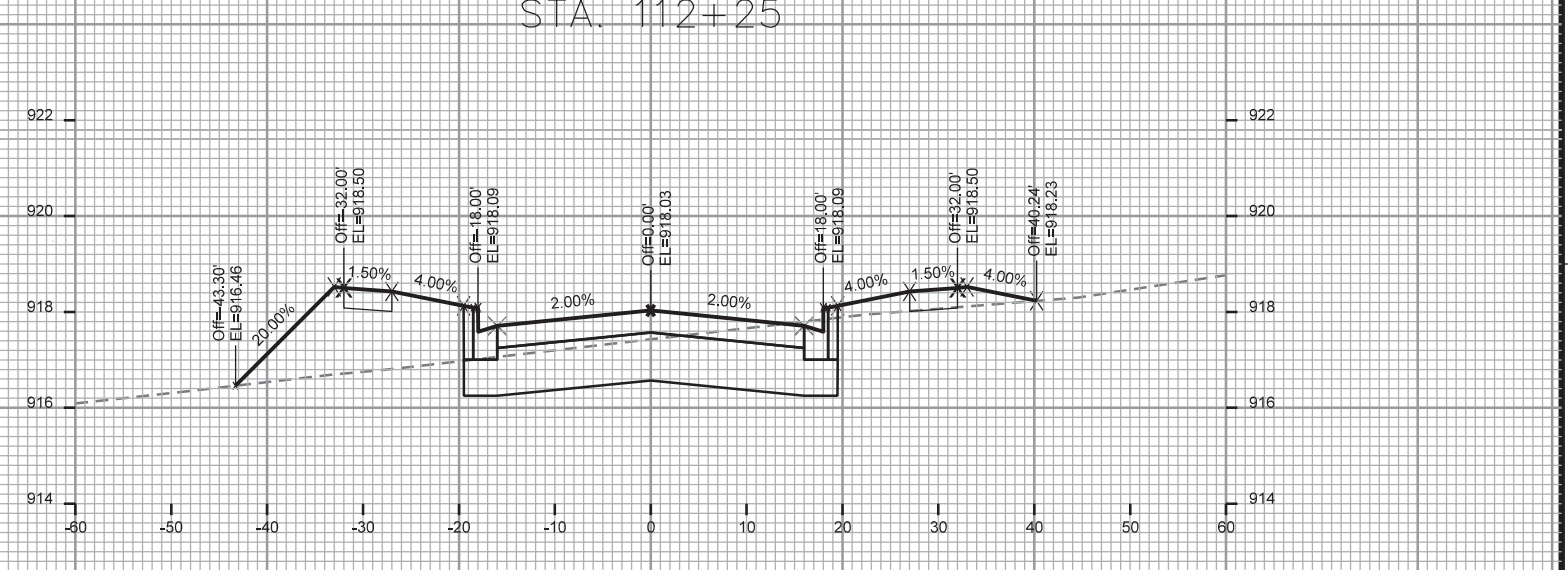
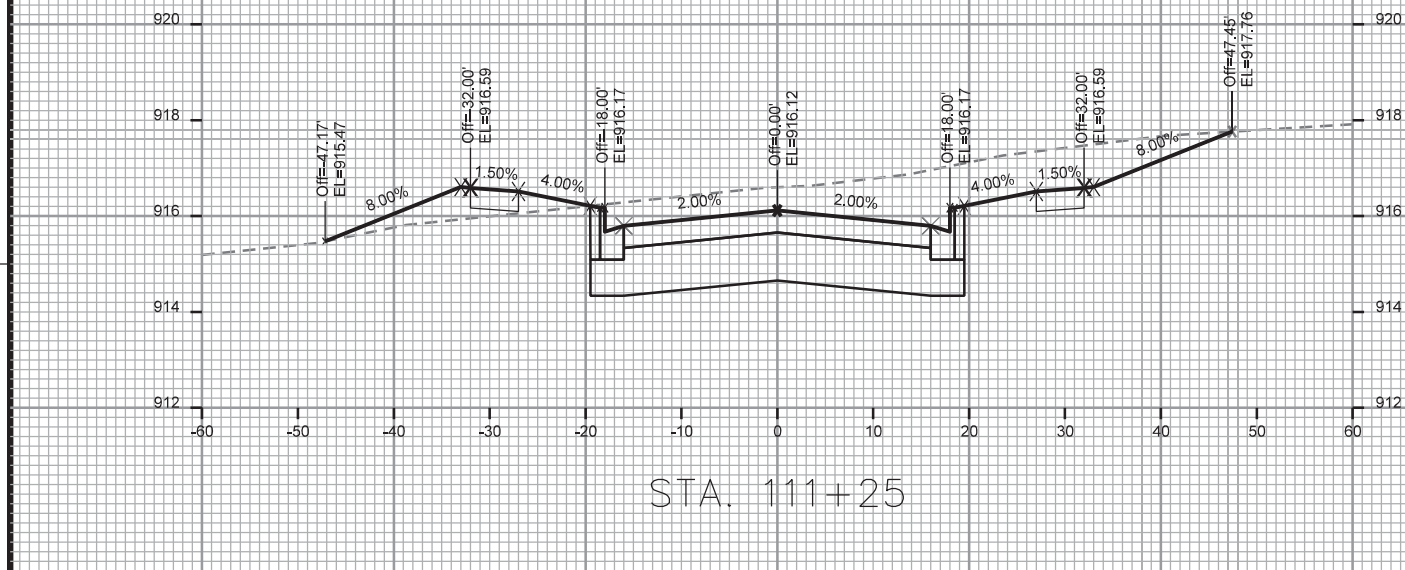
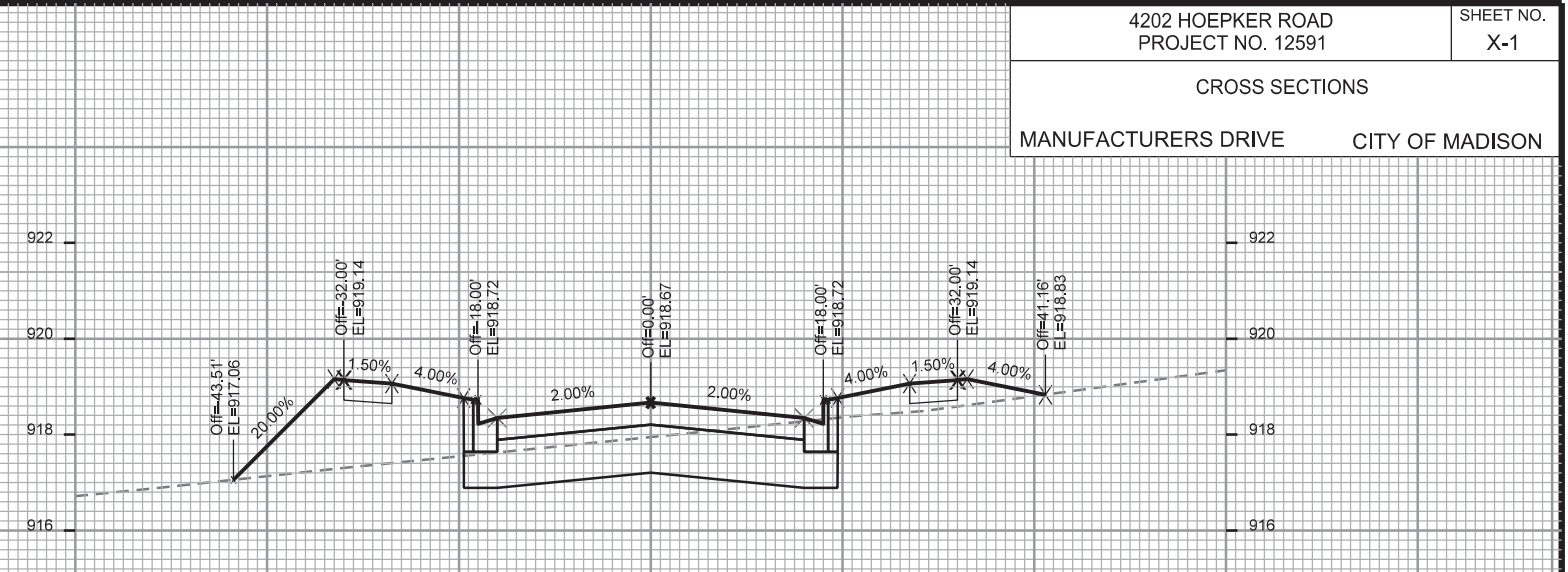
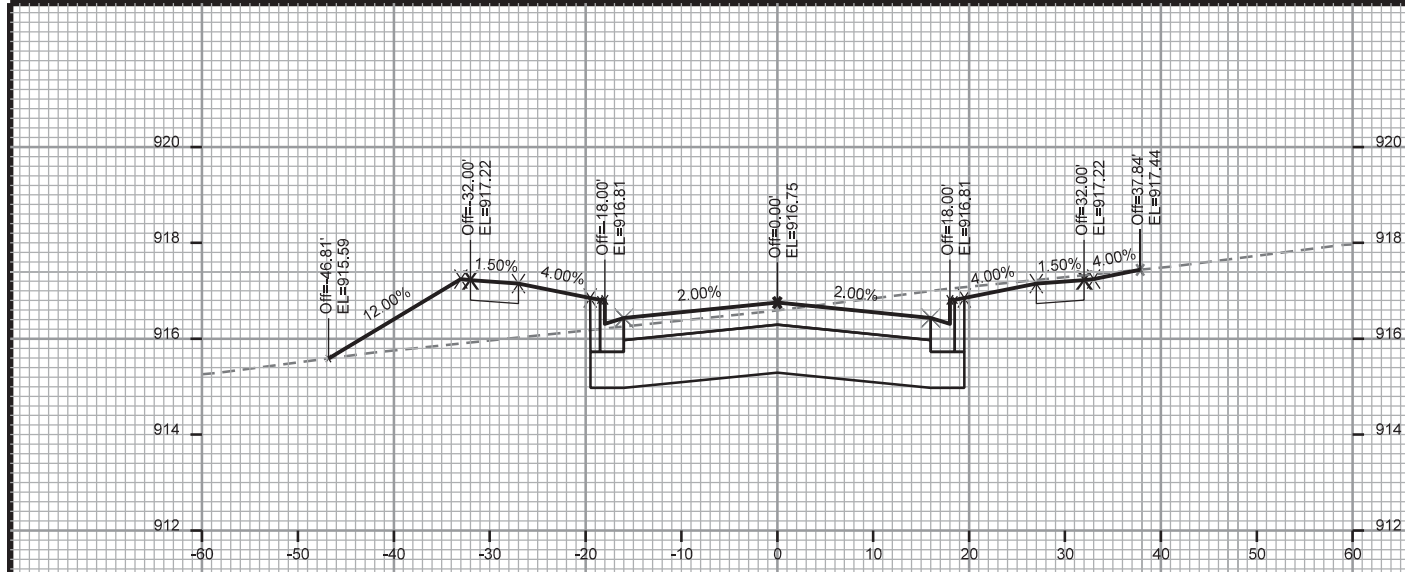

CROSS SECTIONS

MANUFACTURERS DRIVE CITY OF MADISON

PLOT SCALE: \_\_\_\_\_

PLOT NAME: \_\_\_\_\_

REV. DATE: \_\_\_\_\_

ORIGINATOR: CITY OF MADISON STREETS DIVISION

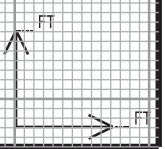
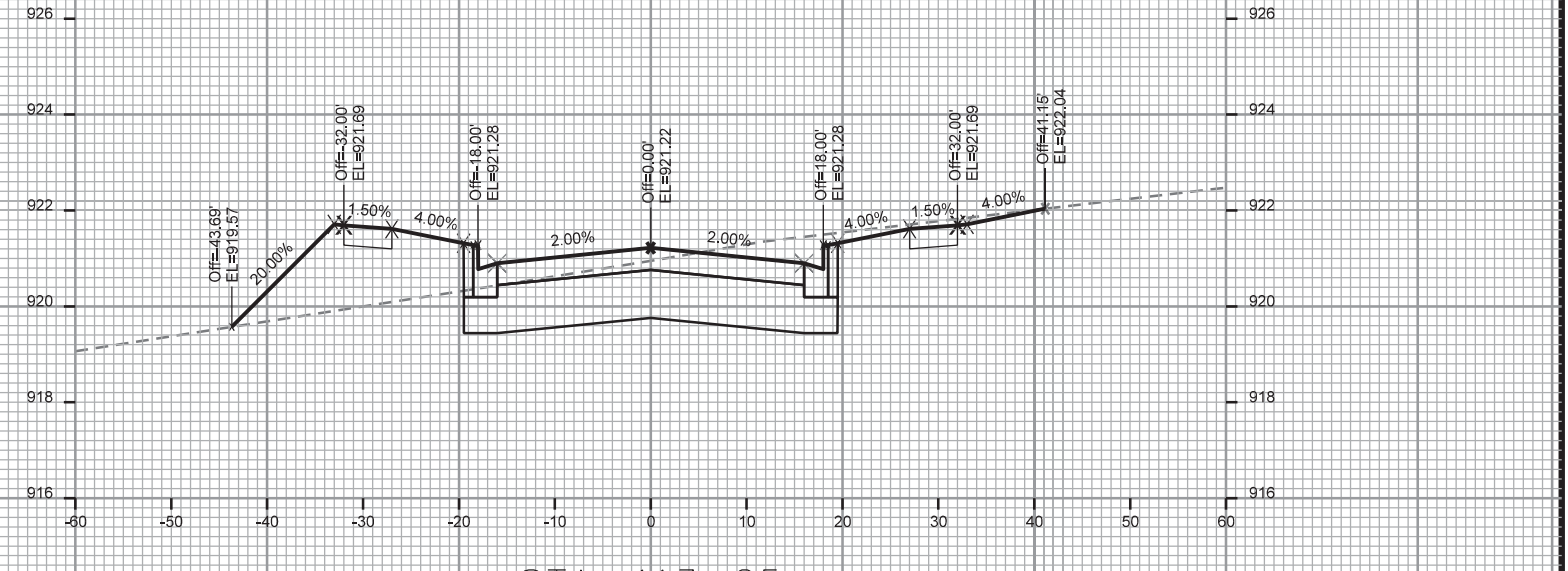
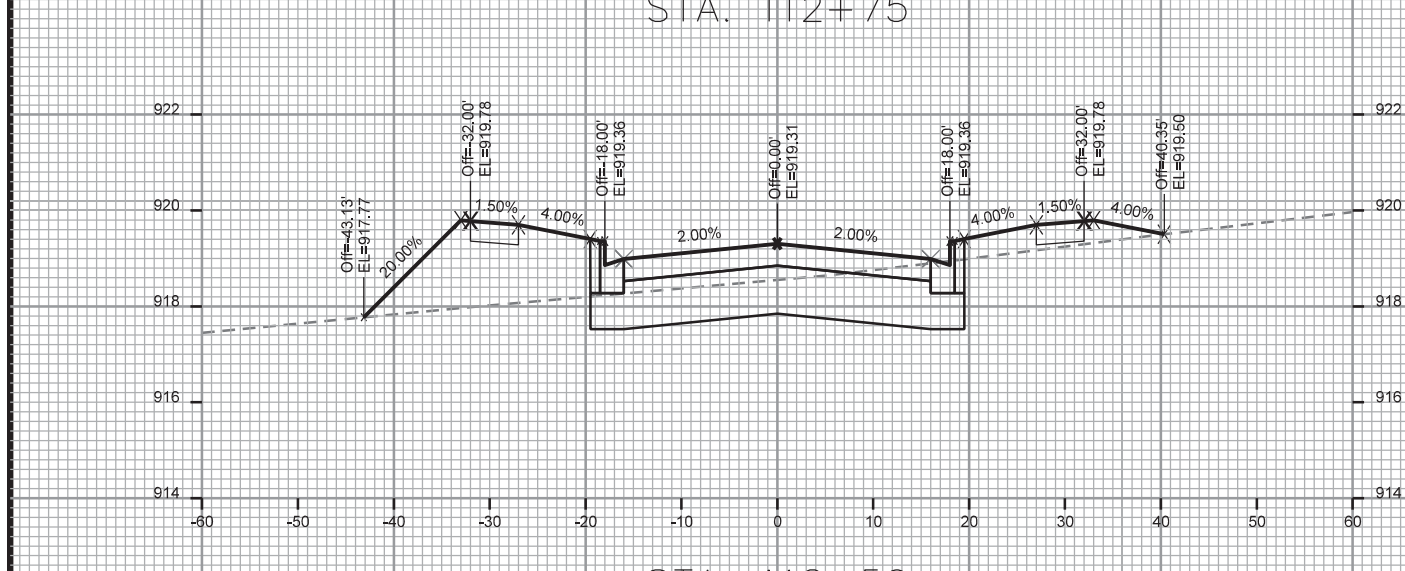
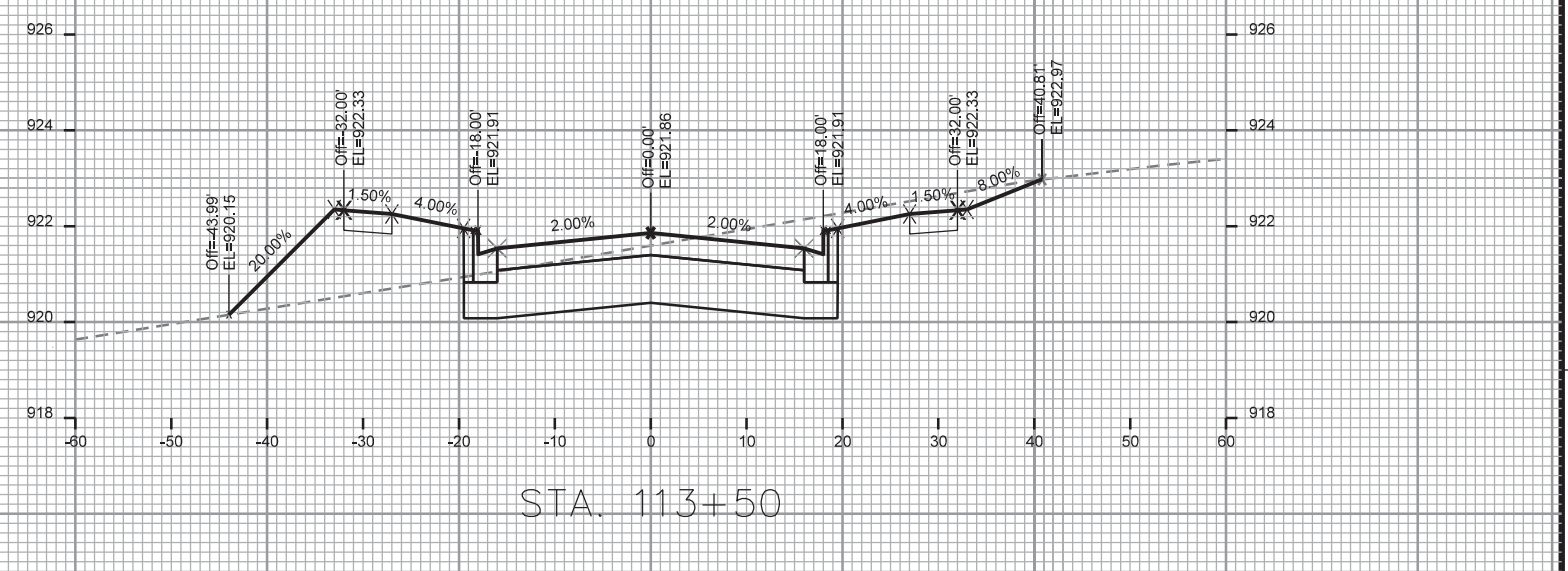
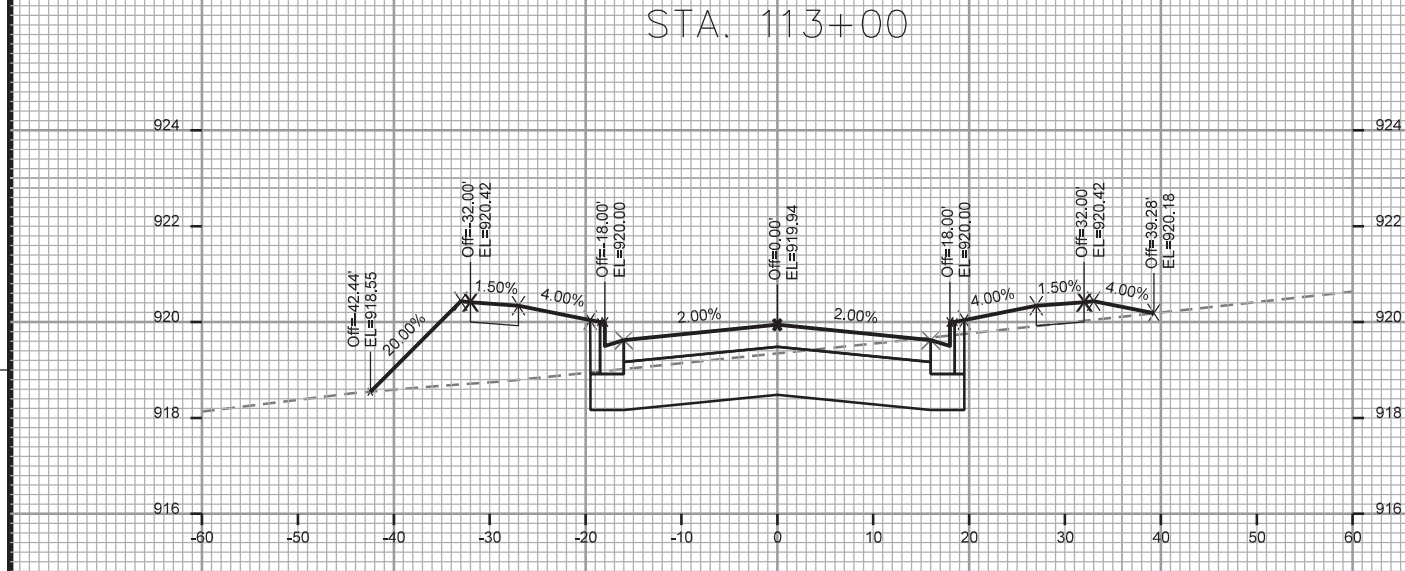
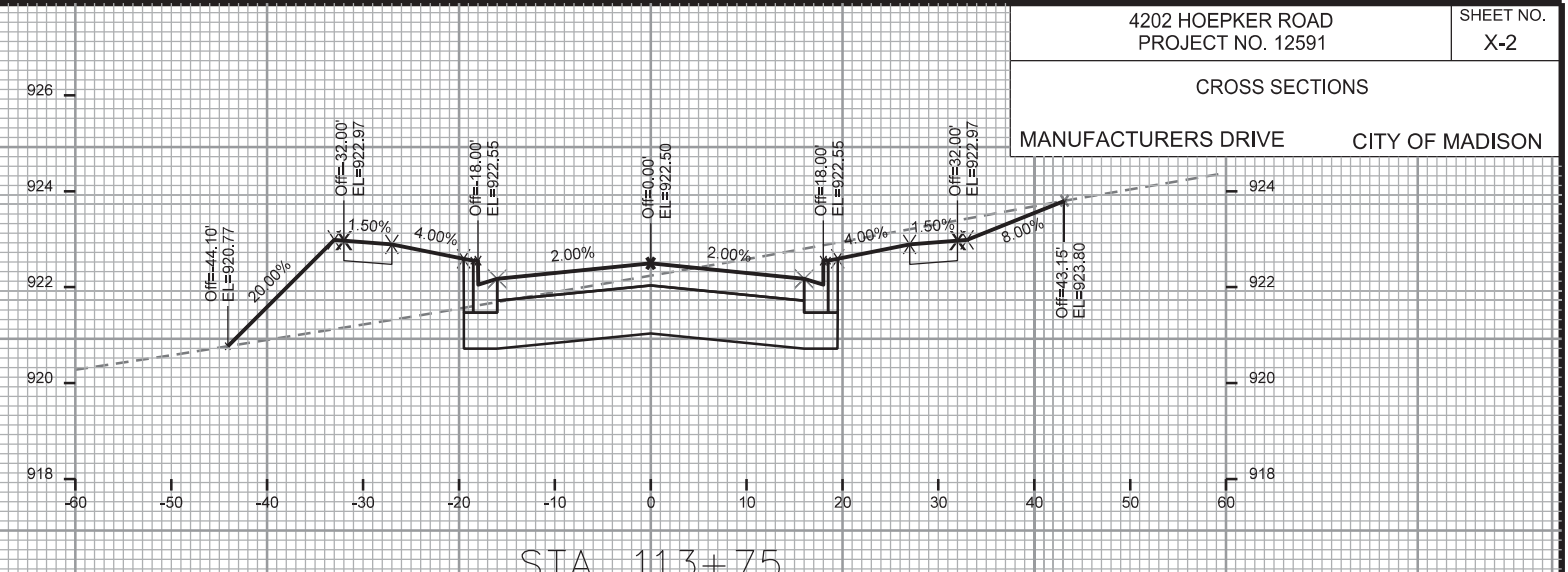
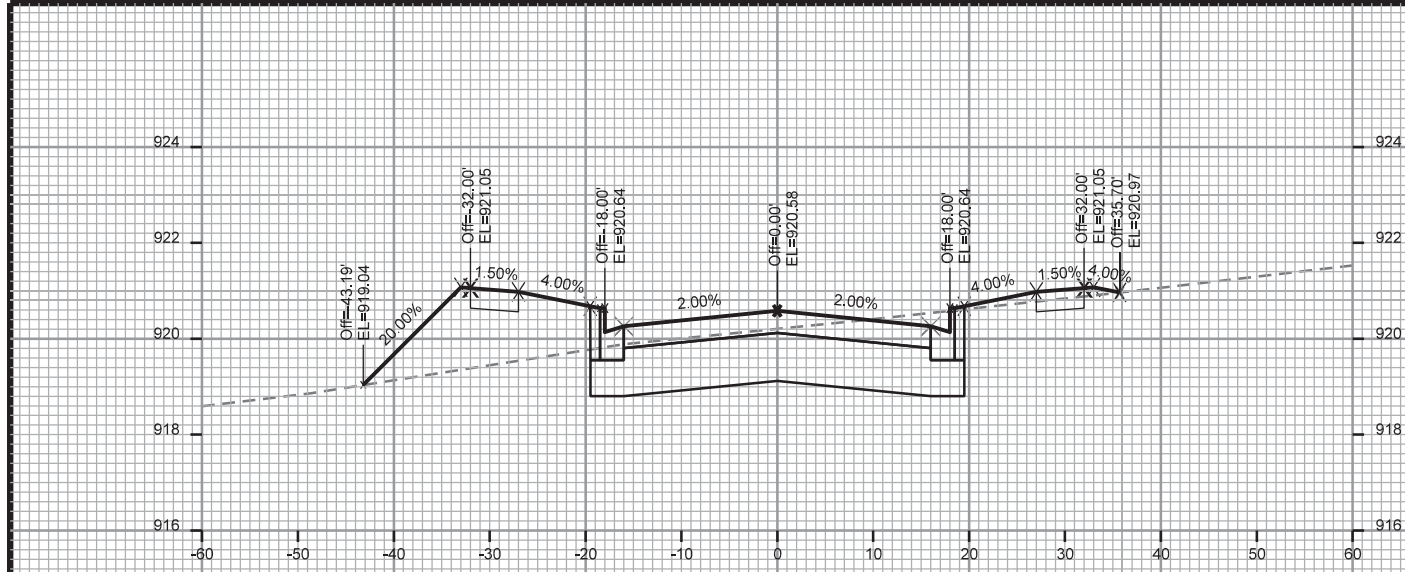

CROSS SECTIONS

MANUFACTURERS DRIVE CITY OF MADISON

PLOT SCALE: \_\_\_\_\_

PLOT NAME: \_\_\_\_\_

REV. DATE: \_\_\_\_\_

ORIGINATOR: CITY OF MADISON STREETS DIVISION

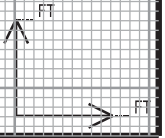
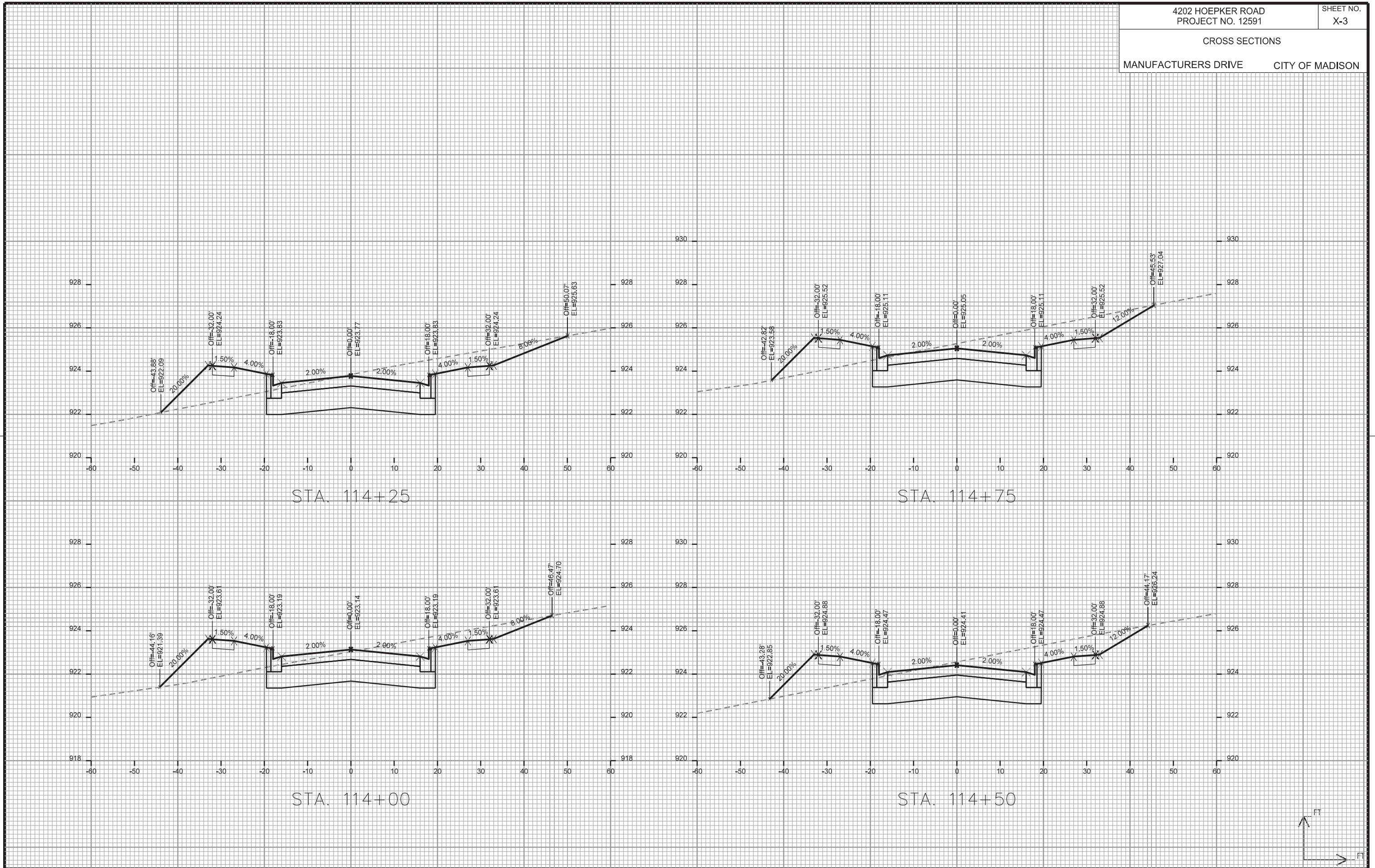

CROSS SECTIONS

MANUFACTURERS DRIVE CITY OF MADISON

PLOT SCALE: \_\_\_\_\_

PLOT NAME: \_\_\_\_\_

REV. DATE: \_\_\_\_\_

ORIGINATOR: CITY OF MADISON STREETS DIVISION

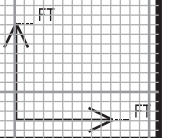
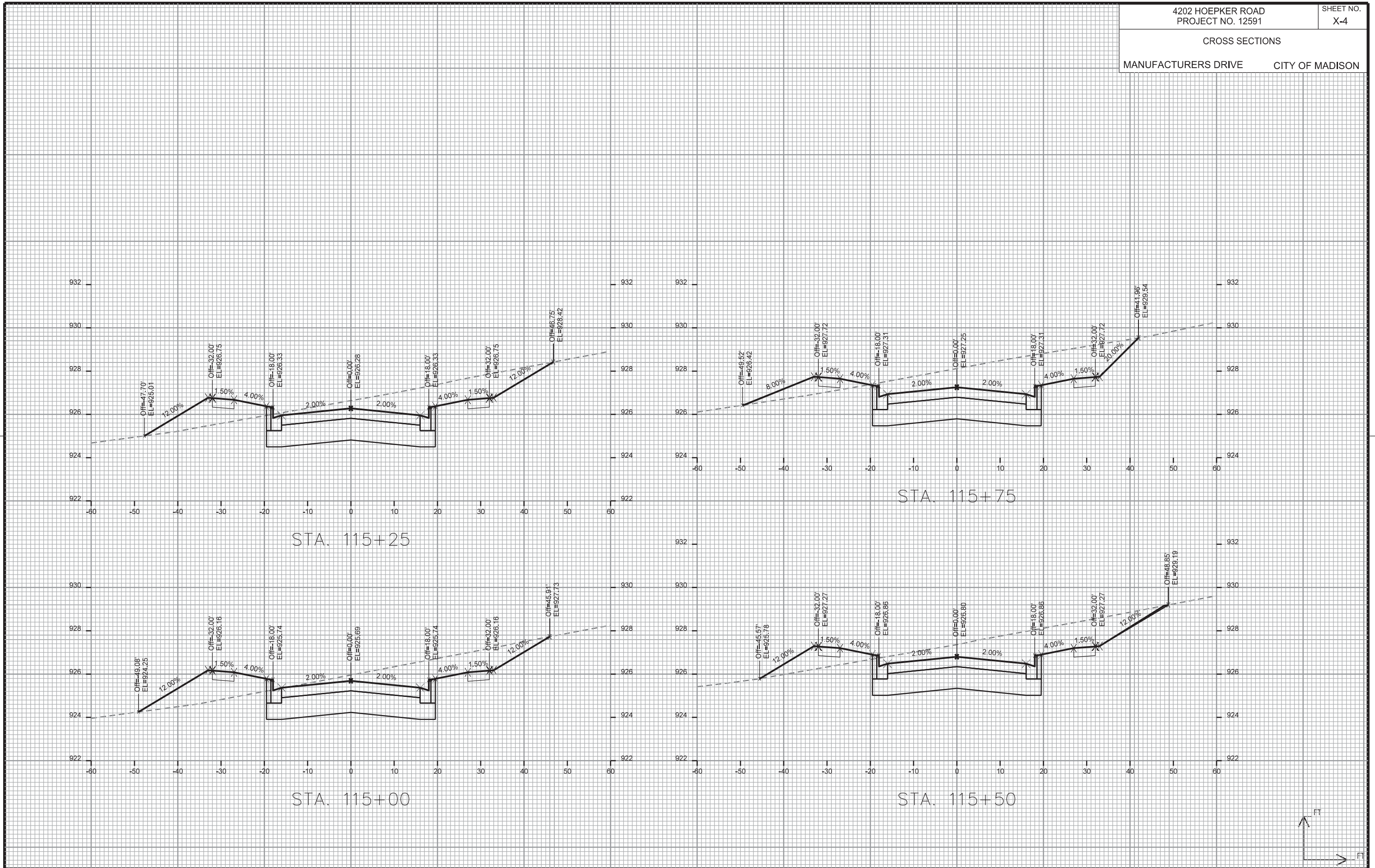

CROSS SECTIONS

MANUFACTURERS DRIVE

CITY OF MADISON

PLOT SCALE: \_\_\_\_\_

PLOT NAME: \_\_\_\_\_

REV. DATE: \_\_\_\_\_

ORIGINATOR: CITY OF MADISON STREETS DIVISION

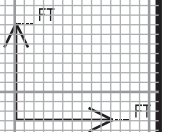
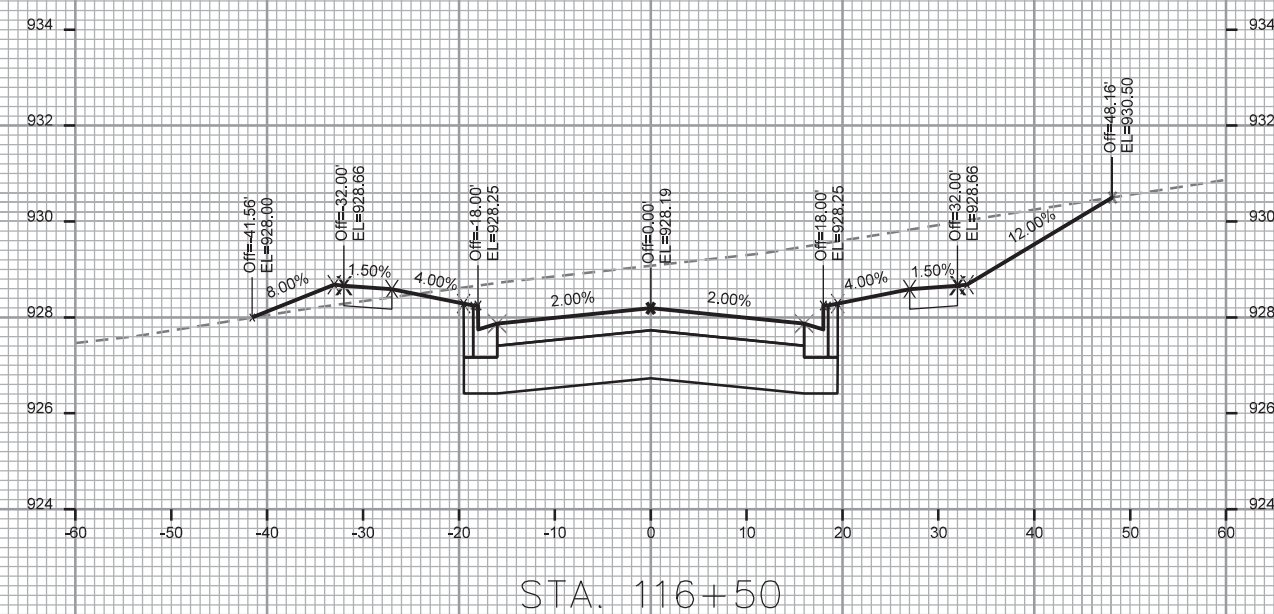
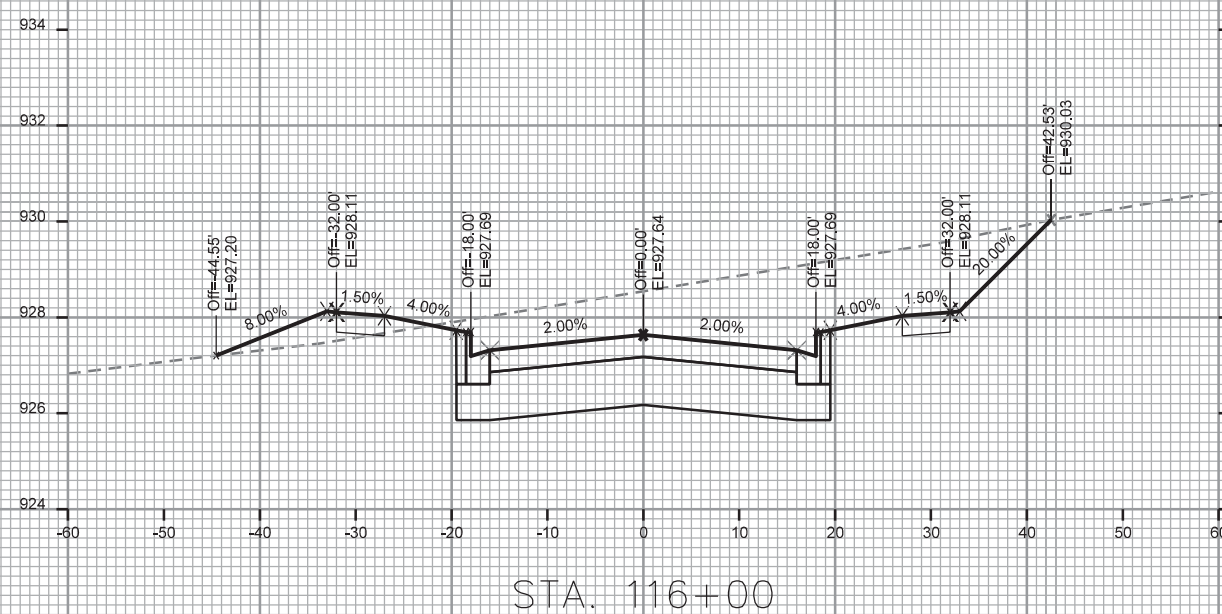
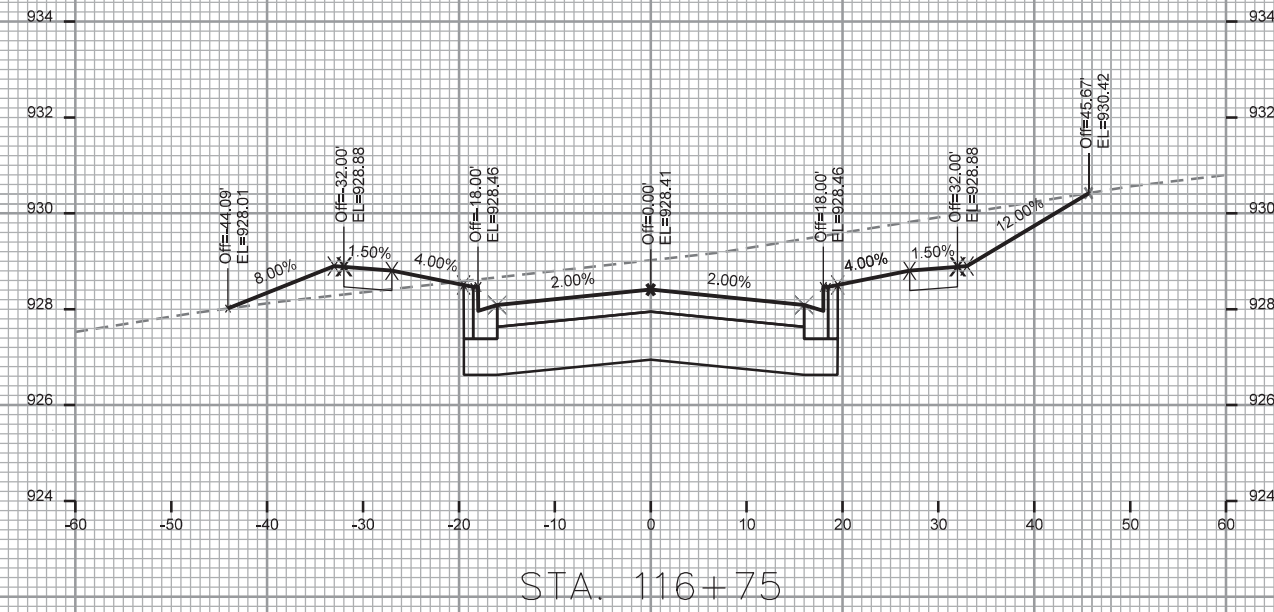
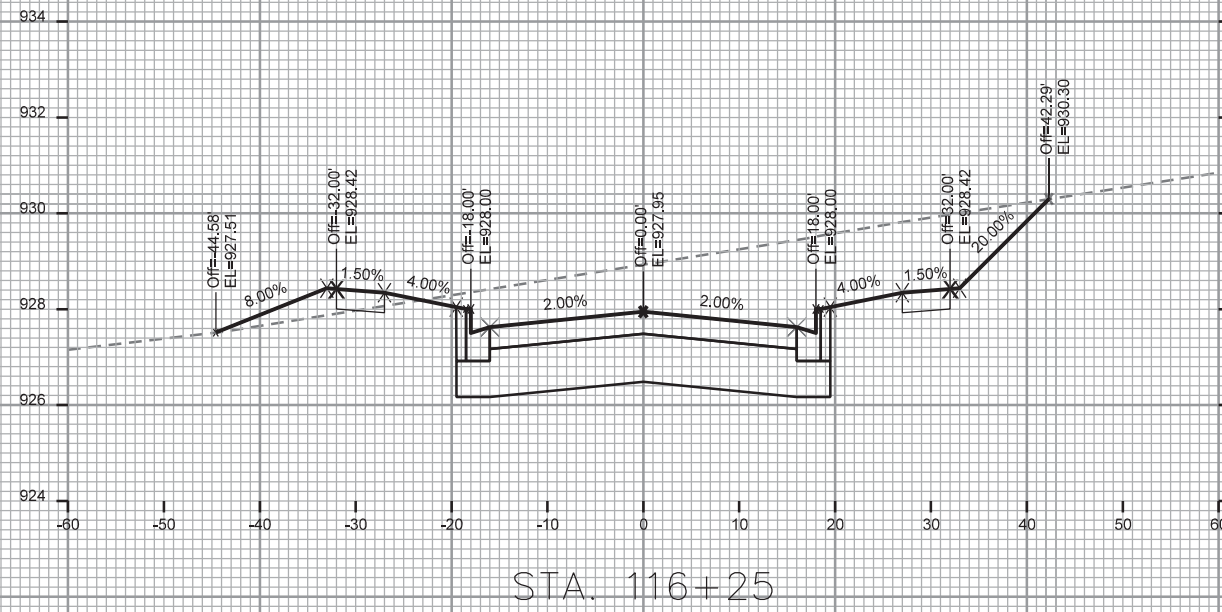

CROSS SECTIONS  
MANUFACTURERS DRIVE CITY OF MADISON

PLOT SCALE: \_\_\_\_\_

PLOT NAME: \_\_\_\_\_

REV. DATE: \_\_\_\_\_

ORIGINATOR: CITY OF MADISON STREETS DIVISION

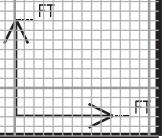
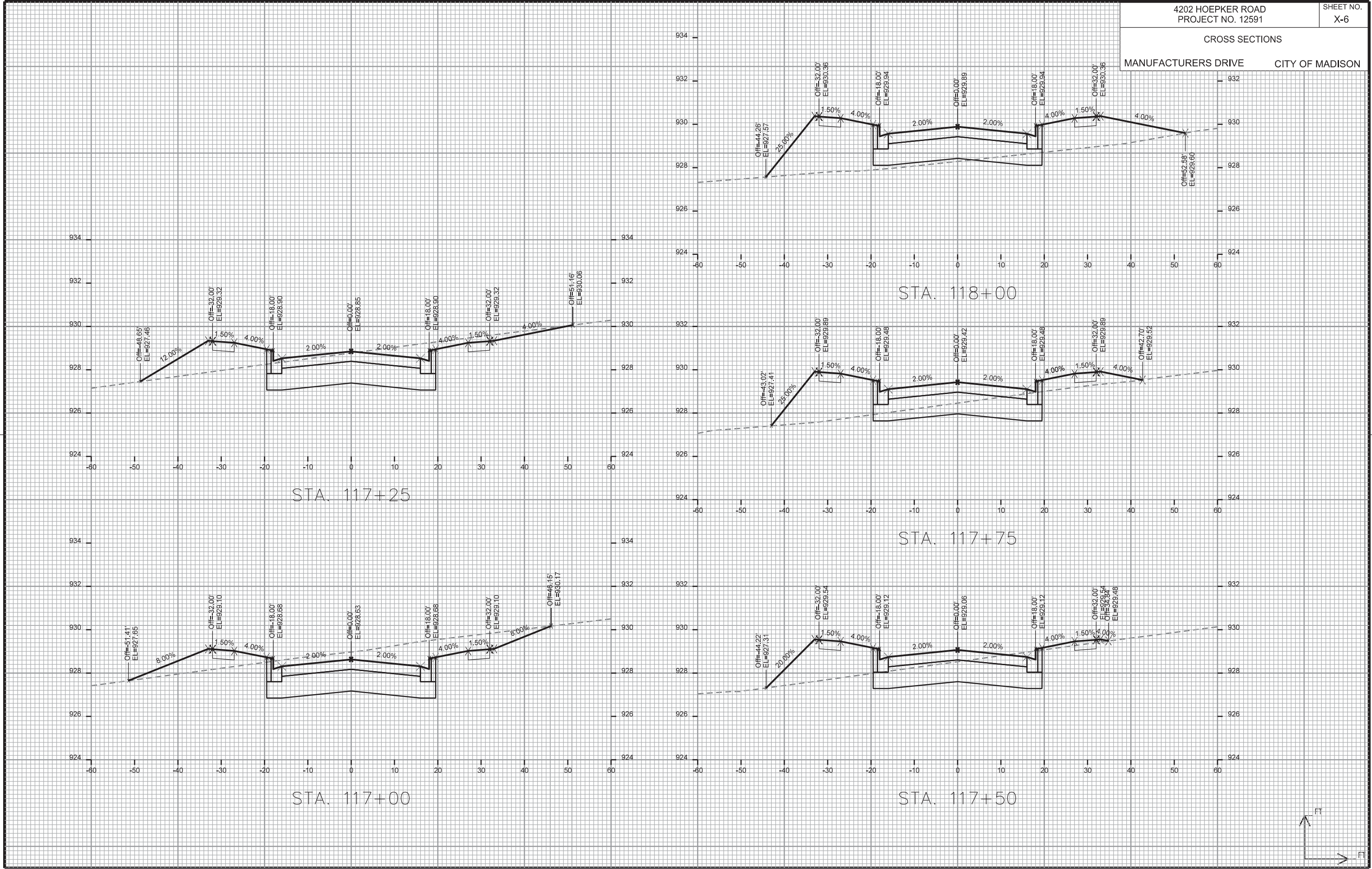

CROSS SECTIONS

MANUFACTURERS DRIVE CITY OF MADISON

PLOT SCALE: \_\_\_\_\_

PLOT NAME: \_\_\_\_\_

REV. DATE: \_\_\_\_\_

ORIGINATOR: CITY OF MADISON STREETS DIVISION

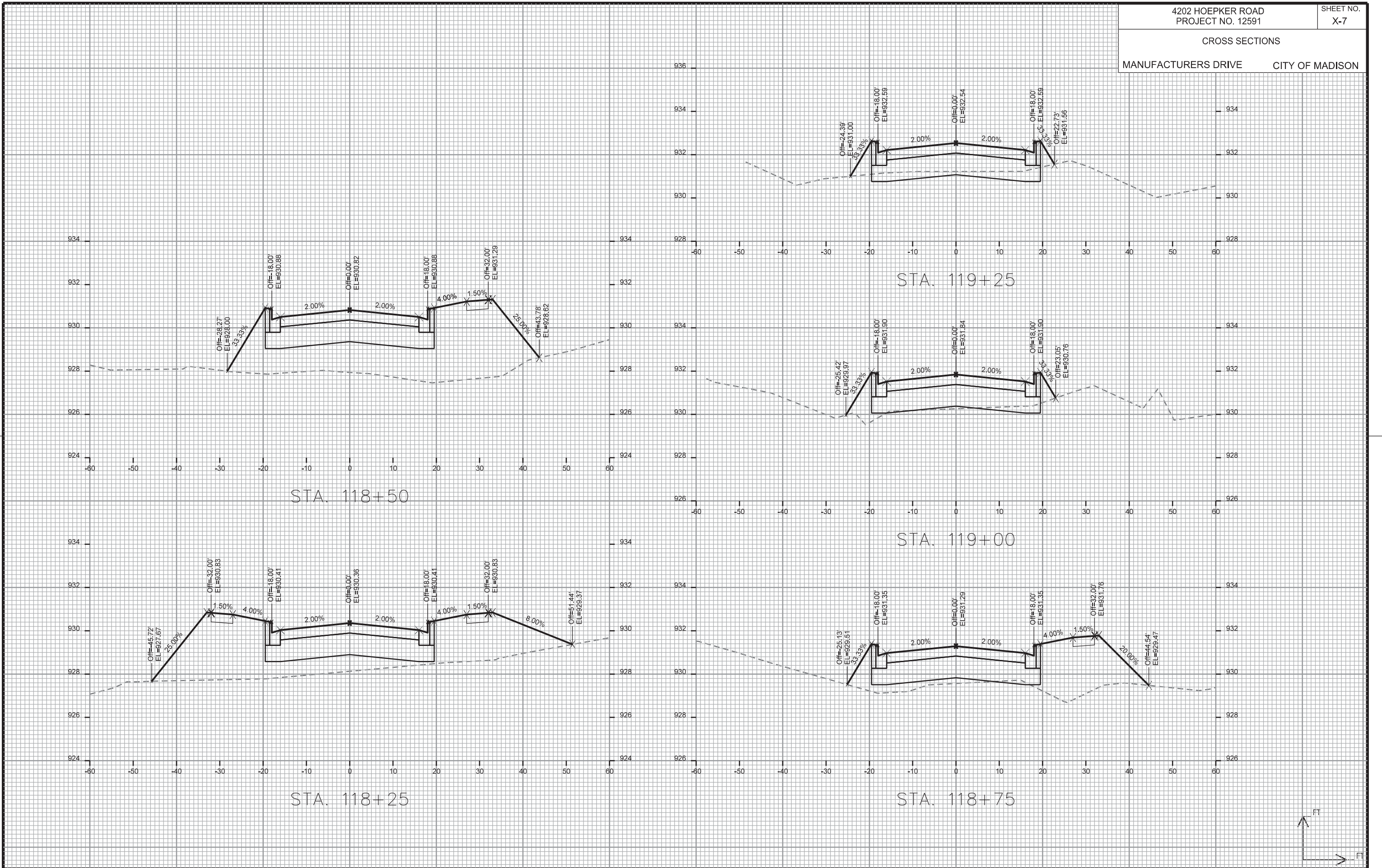



CROSS SECTIONS  
MANUFACTURERS DRIVE CITY OF MADISON

PLOT SCALE: \_\_\_\_\_

PLOT NAME: \_\_\_\_\_

REV. DATE: \_\_\_\_\_

ORIGINATOR: CITY OF MADISON - STREETS DIVISION

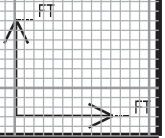
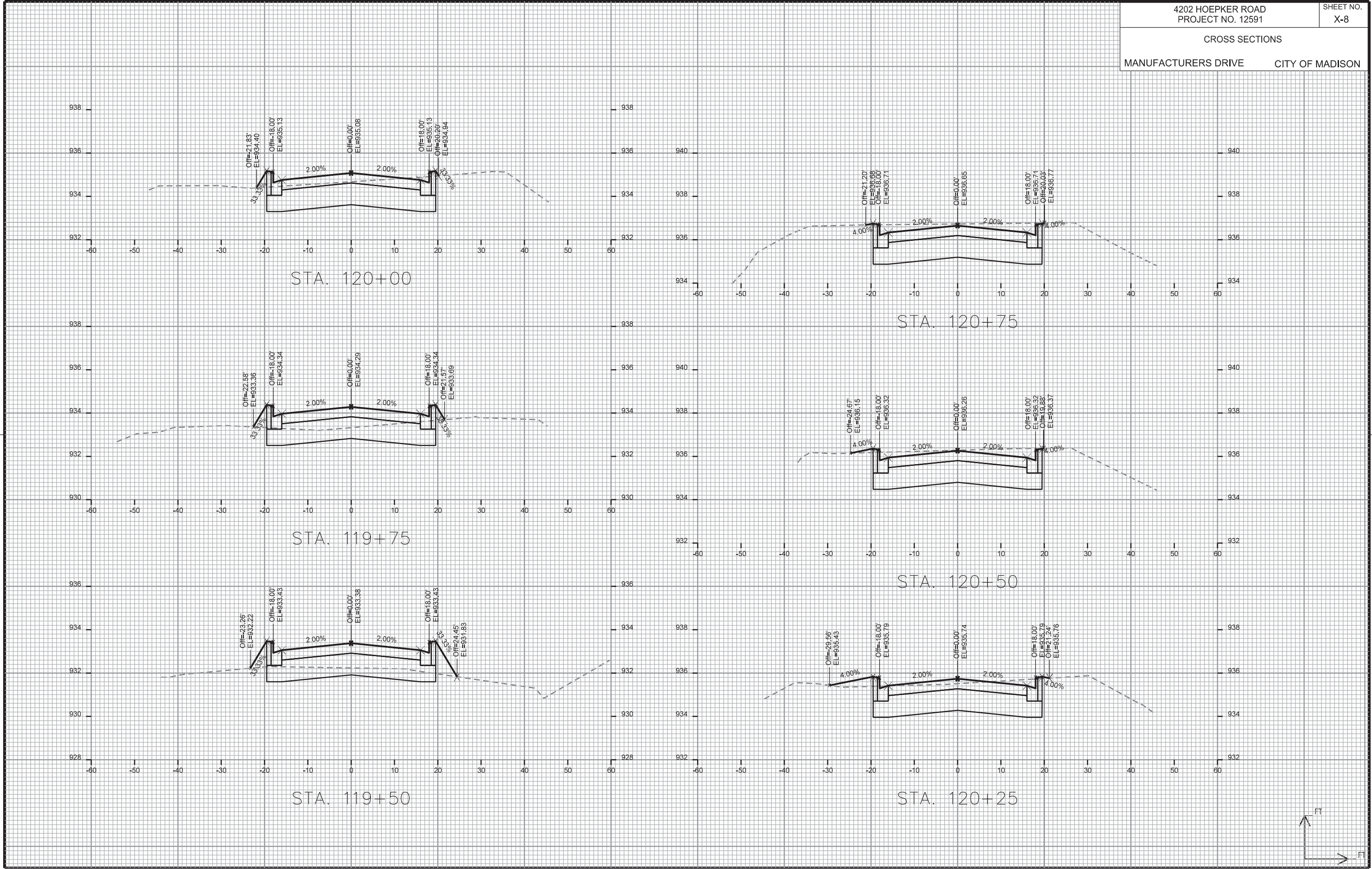

CROSS SECTIONS  
MANUFACTURERS DRIVE CITY OF MADISON

PLOT SCALE: \_\_\_\_\_

PLOT NAME: \_\_\_\_\_

REV. DATE: \_\_\_\_\_

ORIGINATOR: CITY OF MADISON STREETS DIVISION

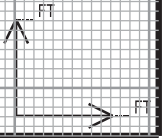
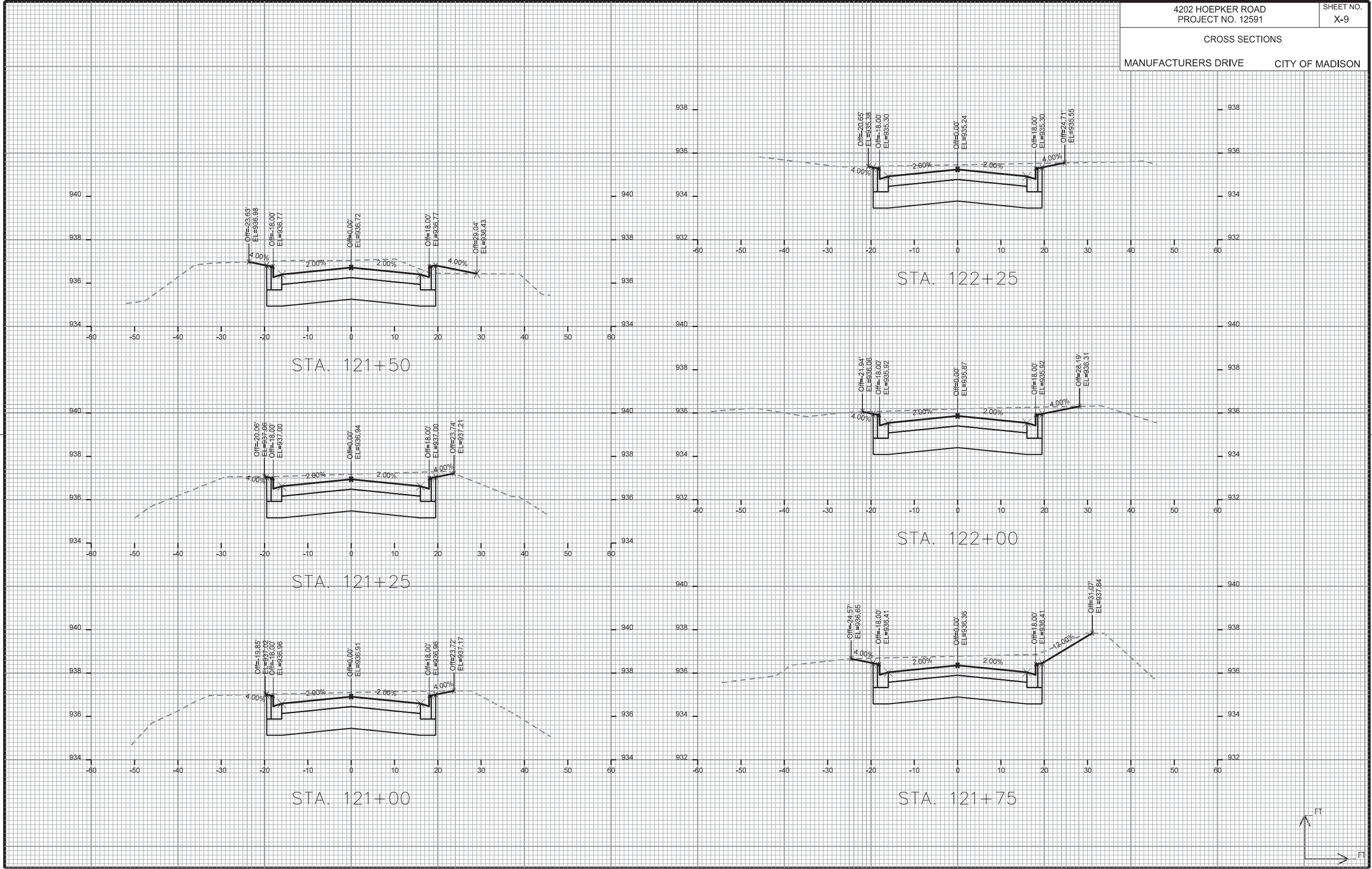

CROSS SECTIONS

MANUFACTURERS DRIVE

CITY OF MADISON

PLOT SCALE: \_\_\_\_\_

PLOT NAME: \_\_\_\_\_

REV. DATE: \_\_\_\_\_

ORIGINATOR: CITY OF MADISON - STREETS DIVISION

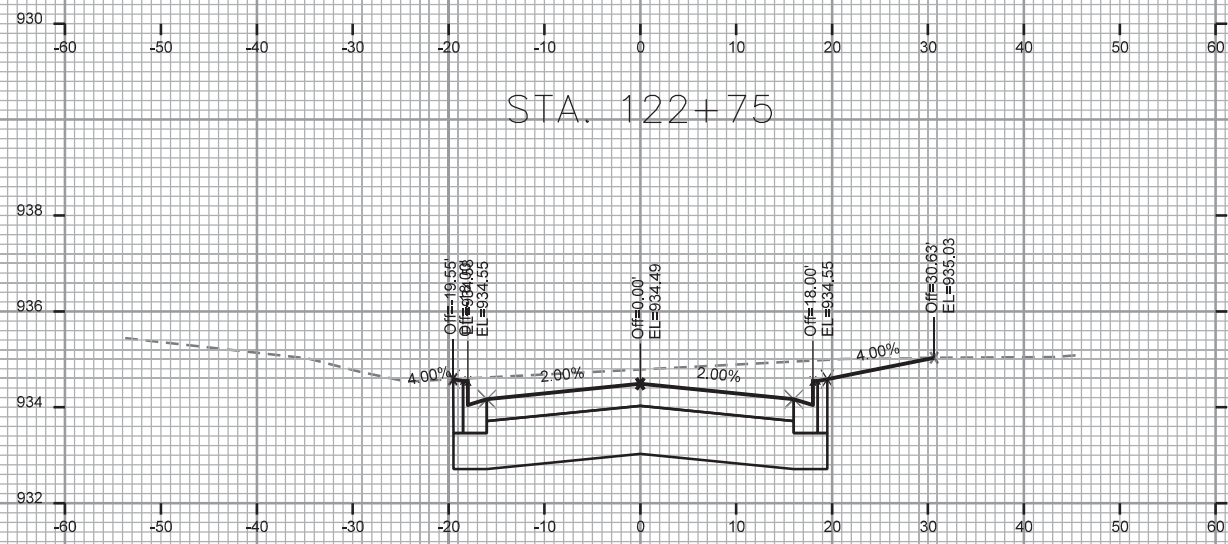
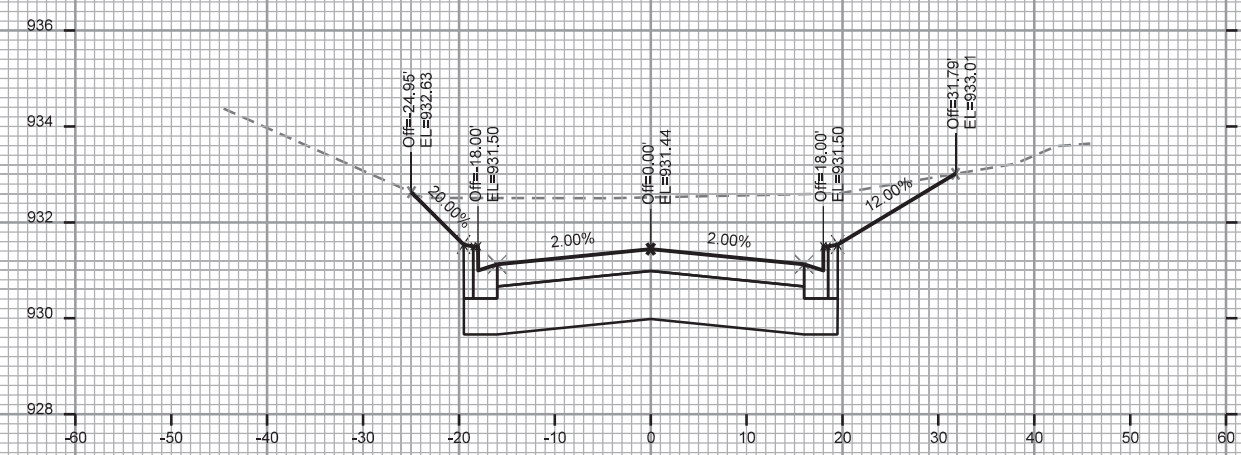
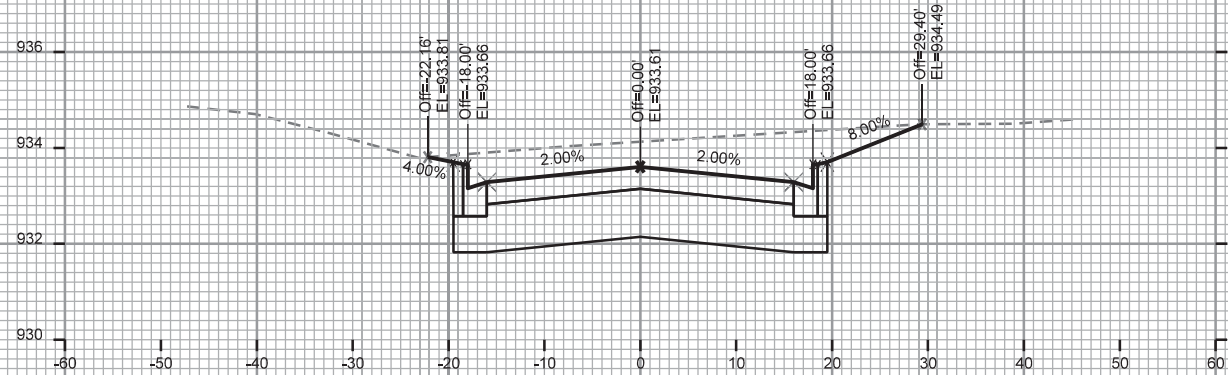
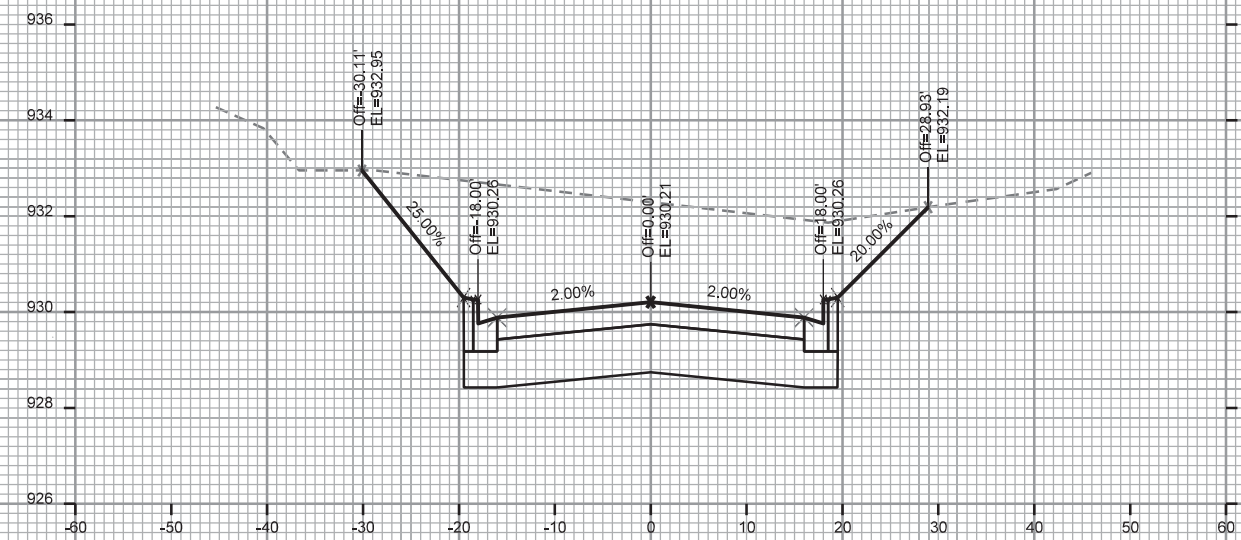
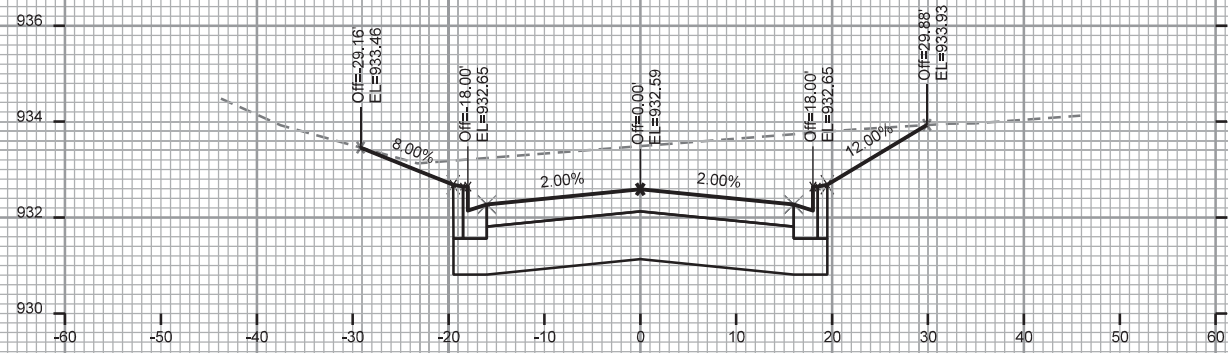

CROSS SECTIONS

MANUFACTURERS DRIVE

CITY OF MADISON

PLOT SCALE: \_\_\_\_\_

PLOT NAME: \_\_\_\_\_

REV. DATE: \_\_\_\_\_

ORIGINATOR: CITY OF MADISON - STREETS DIVISION

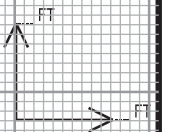
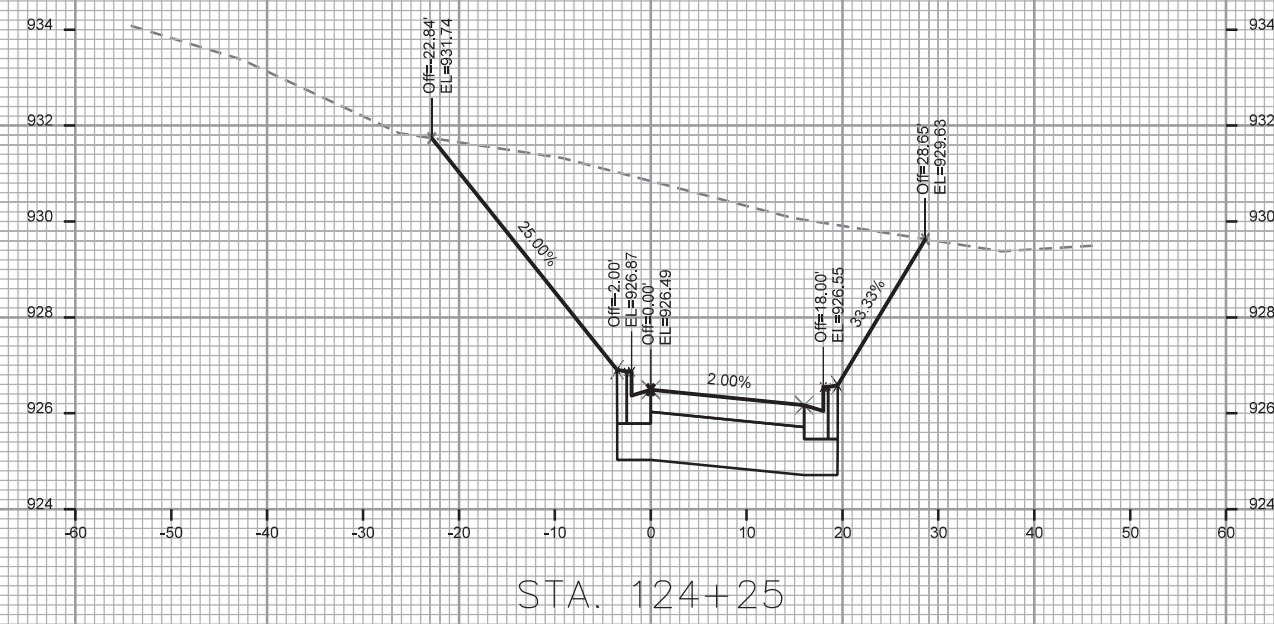
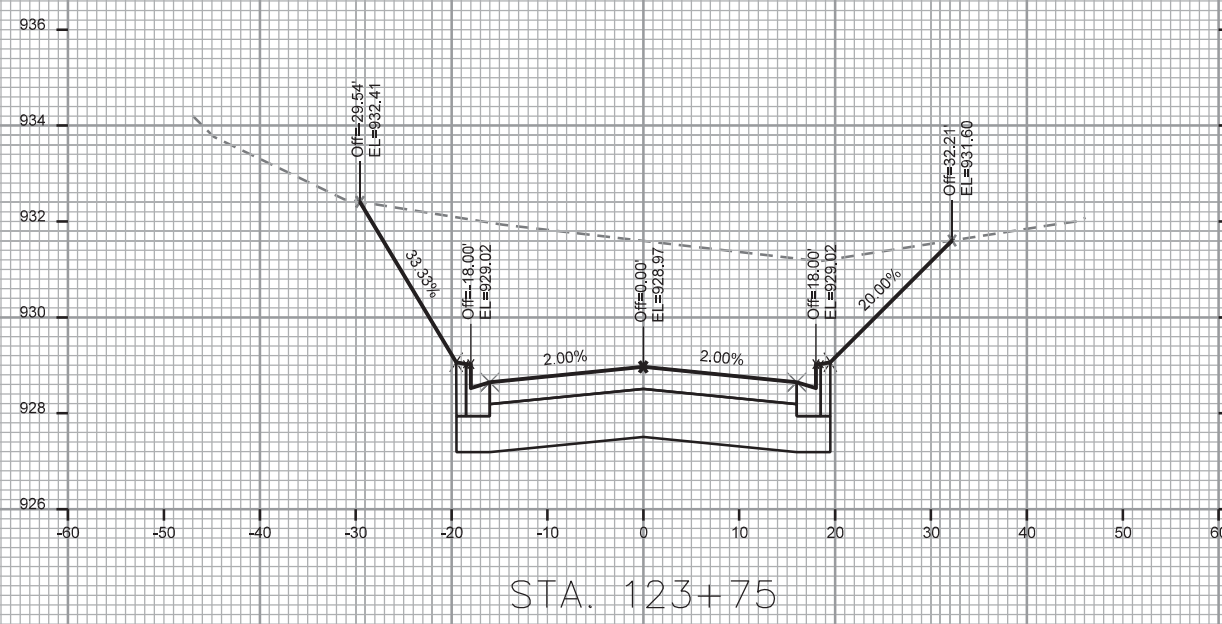
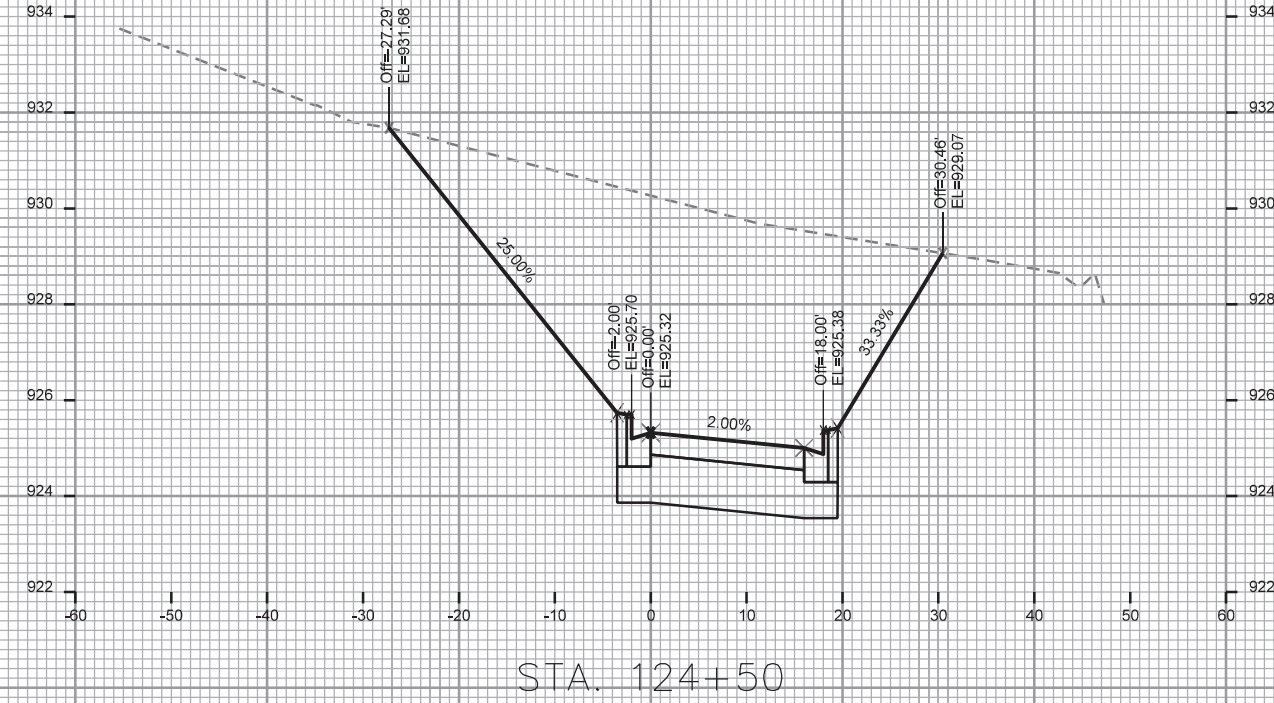
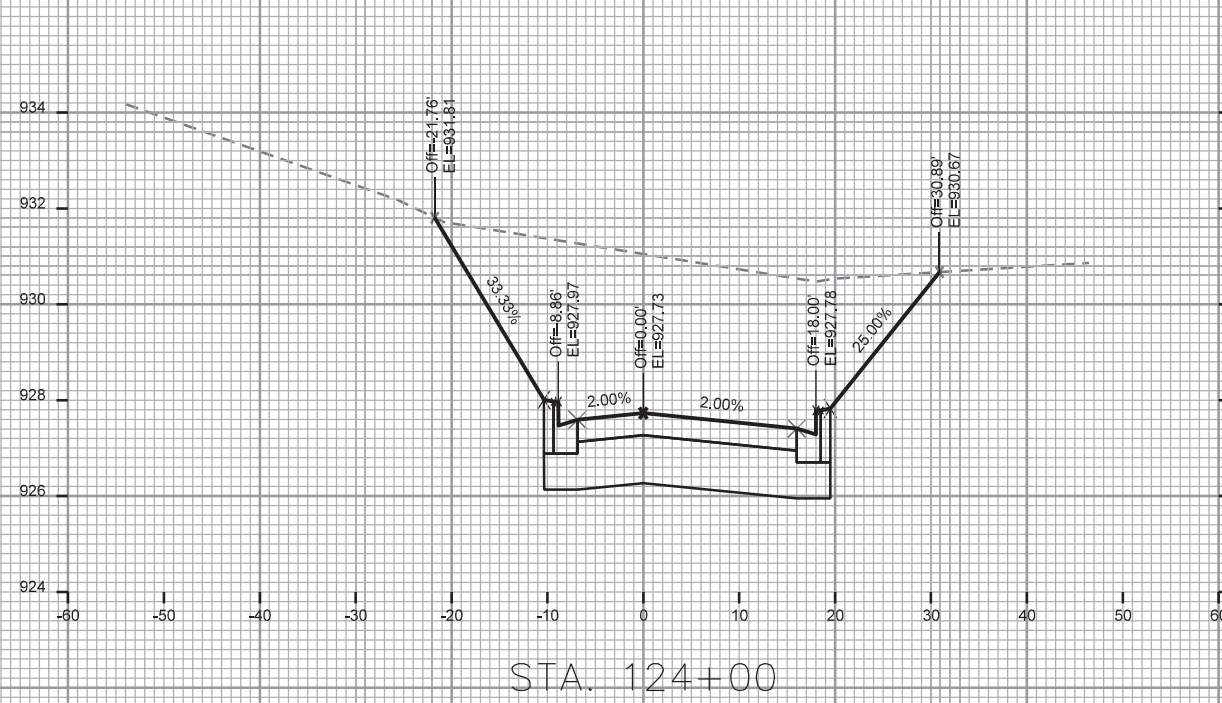

CROSS SECTIONS

MANUFACTURERS DRIVE

CITY OF MADISON

PLOT SCALE: \_\_\_\_\_

PLOT NAME: \_\_\_\_\_

REV. DATE: \_\_\_\_\_

ORIGINATOR: CITY OF MADISON - STREETS DIVISION

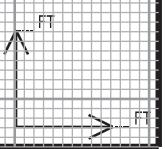
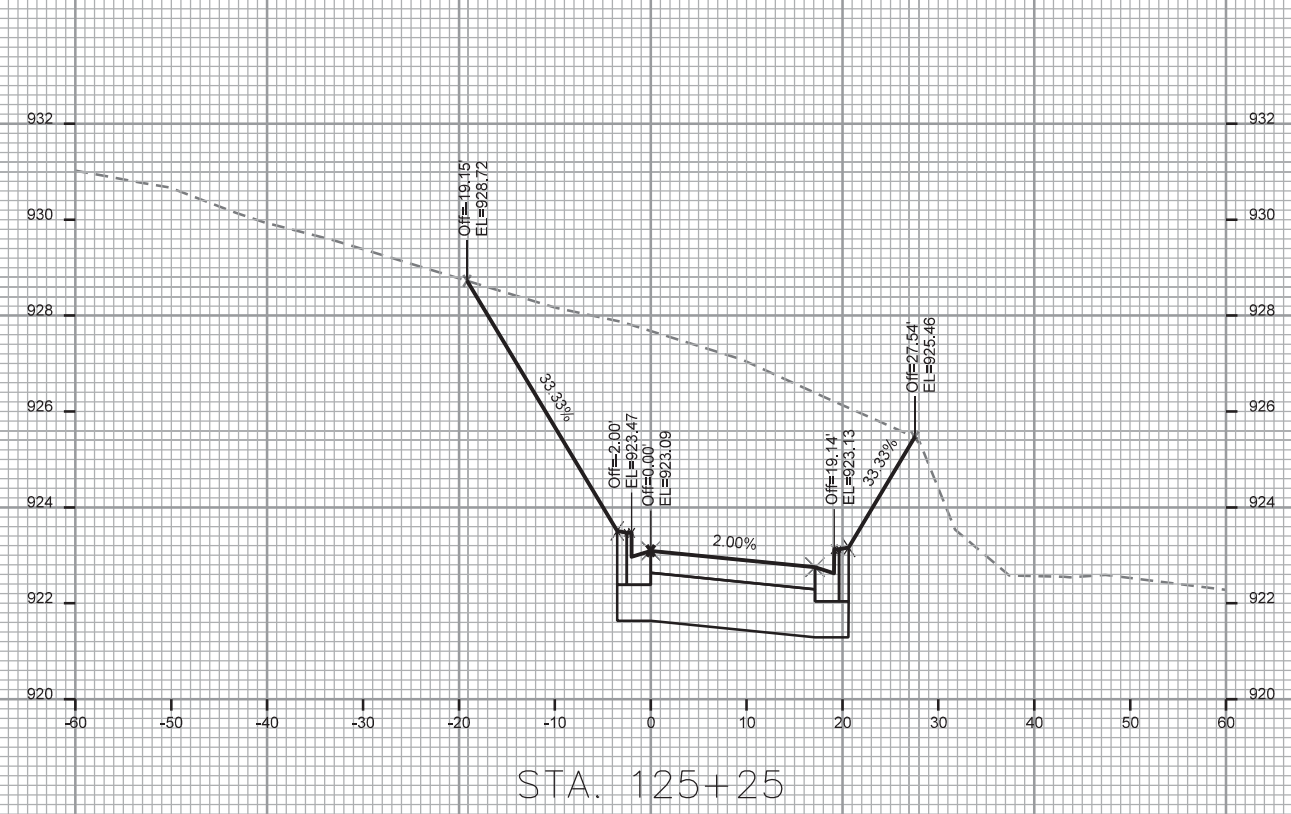
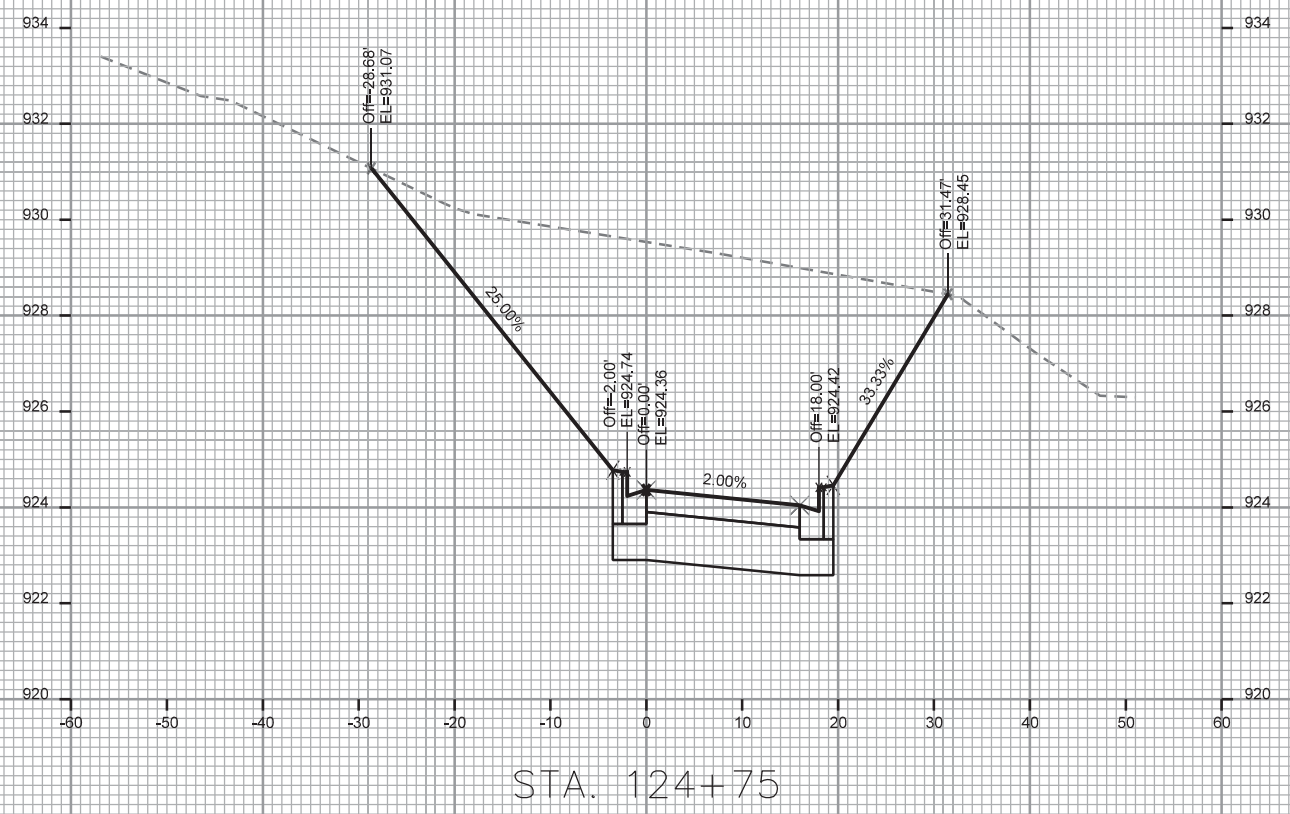
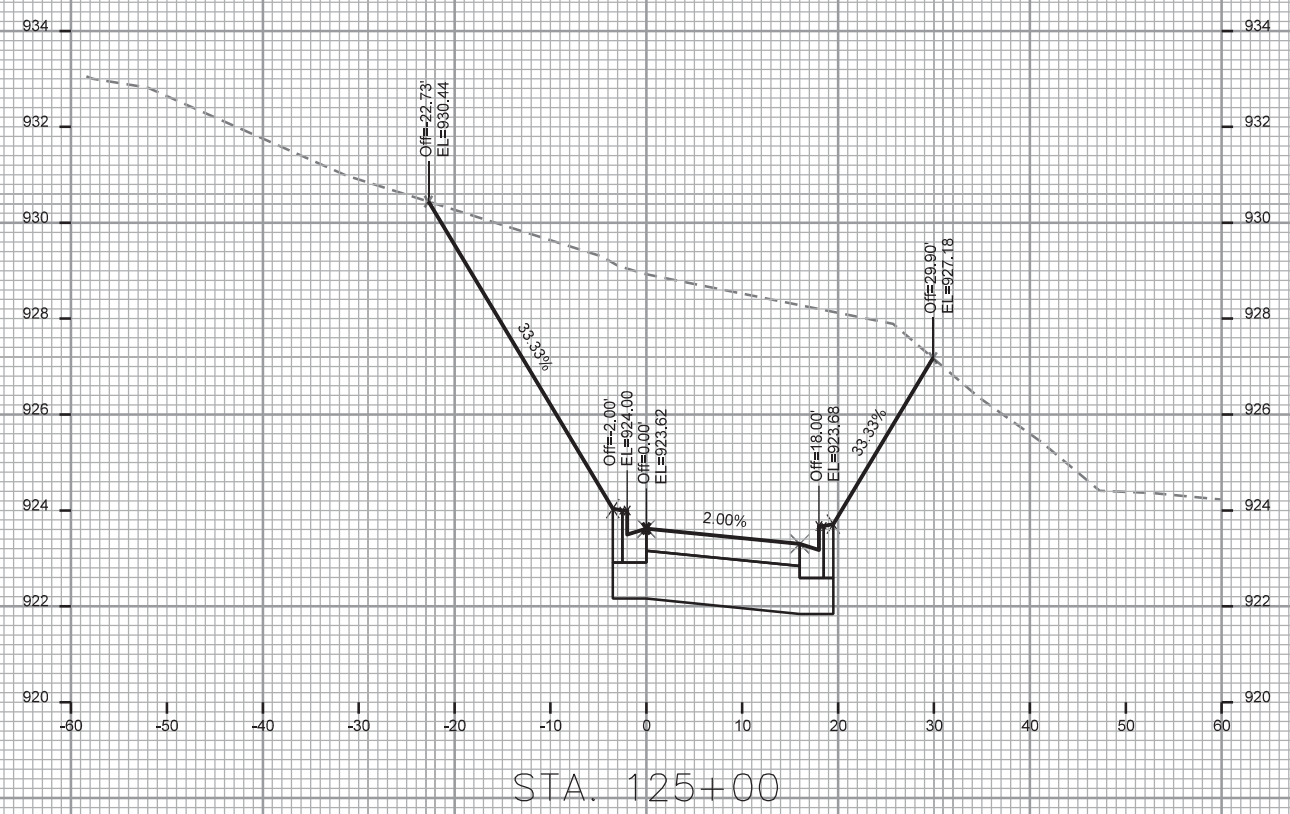

REVISION 5/29/20 AJZ  
- Remove X's

4202 HOEPKER ROAD  
PROJECT NO. 12591

SHEET NO.  
X-13

CROSS SECTIONS  
ANDERSON ROAD CITY OF MADISON

PLOT SCALE: \_\_\_\_\_  
PLOT NAME: \_\_\_\_\_  
REV. DATE: \_\_\_\_\_  
ORIGINATOR: CITY OF MADISON - STREETS DIVISION

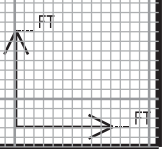
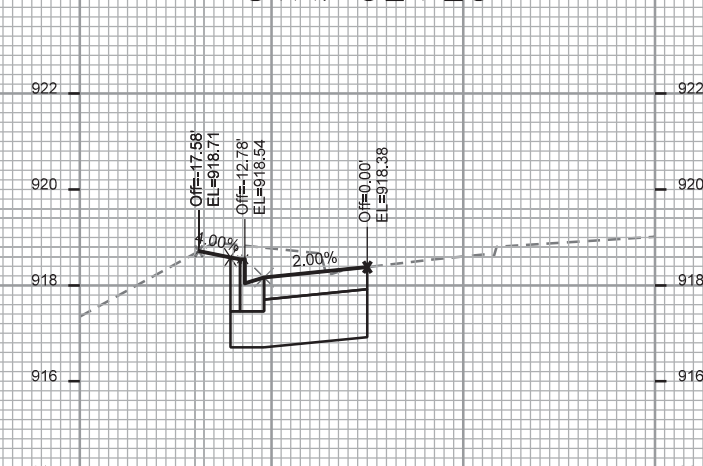
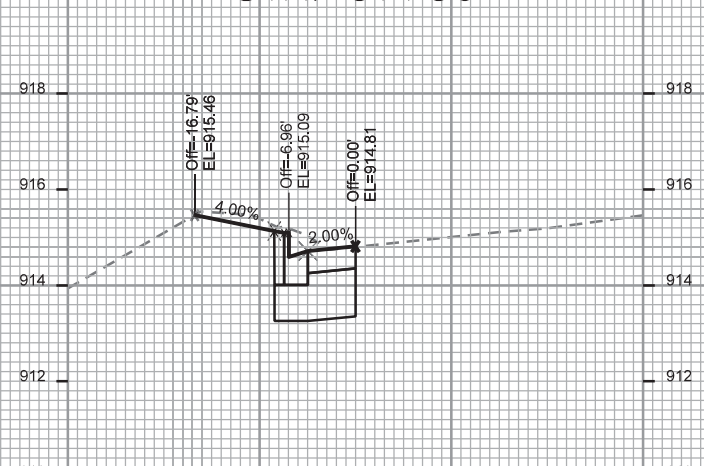
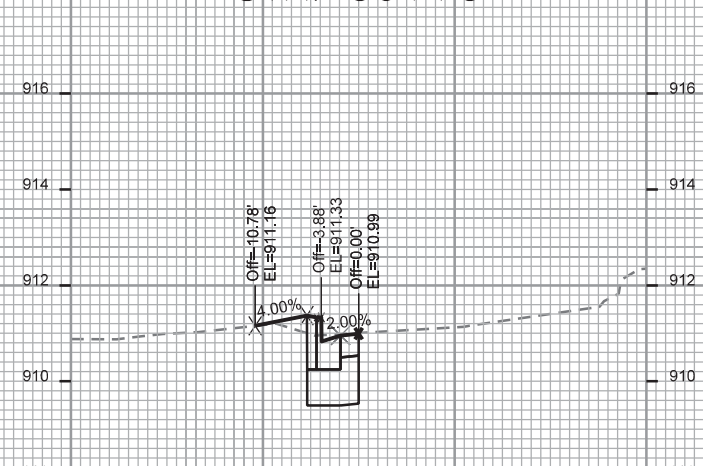
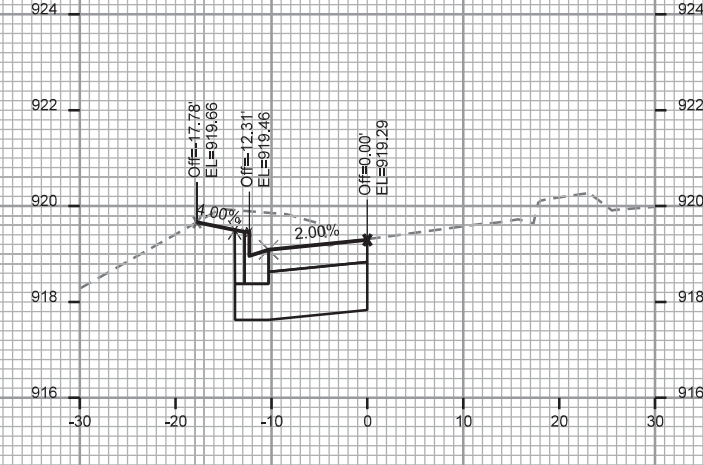
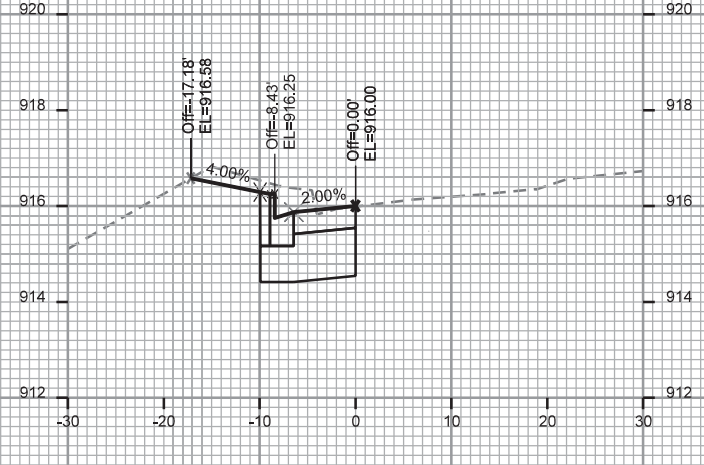
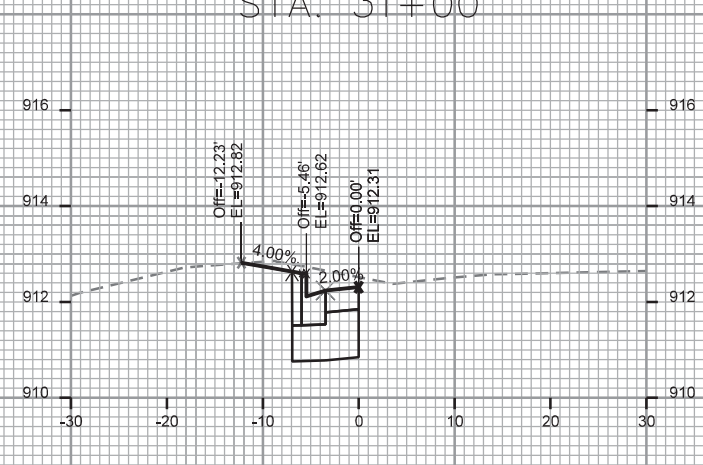
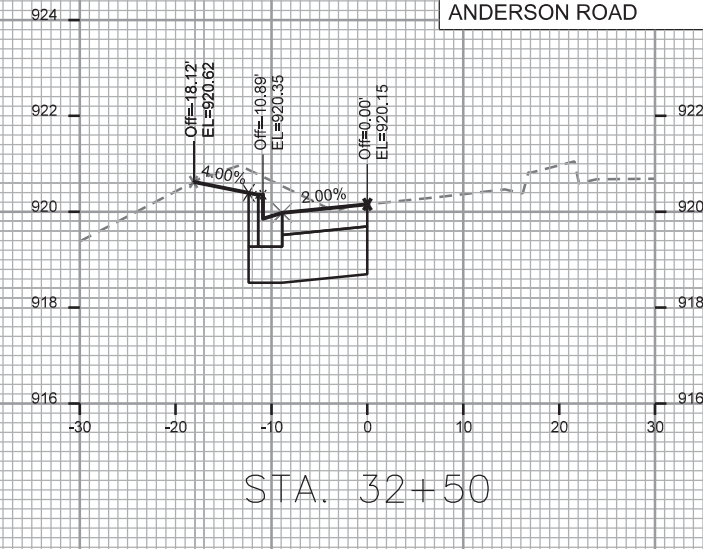
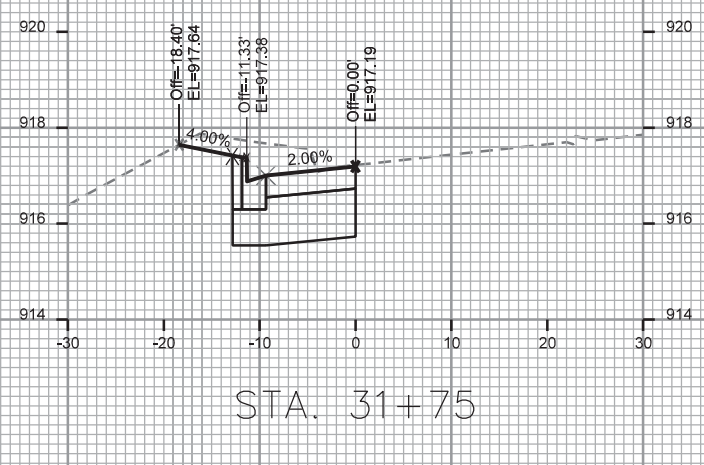
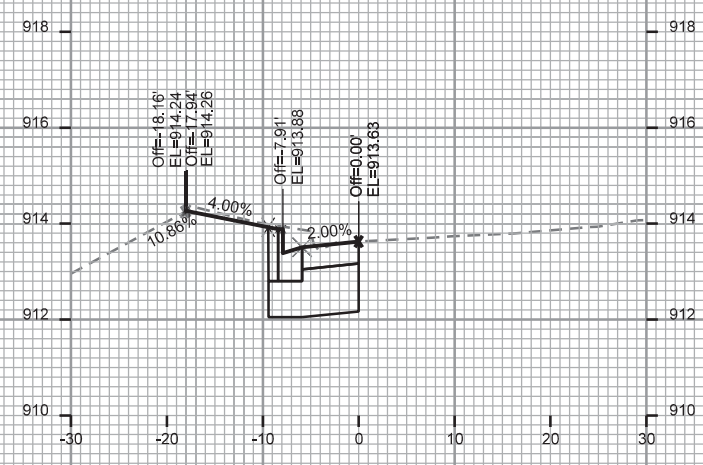

REVISION 5/29/20 AJZ  
- Remove X's

4202 HOEPKER ROAD  
PROJECT NO. 12591

SHEET NO.  
X-14

CROSS SECTIONS  
ANDERSON ROAD CITY OF MADISON

PLOT SCALE: \_\_\_\_\_

PLOT NAME: \_\_\_\_\_

REV. DATE: \_\_\_\_\_

ORIGINATOR: CITY OF MADISON - STREETS DIVISION

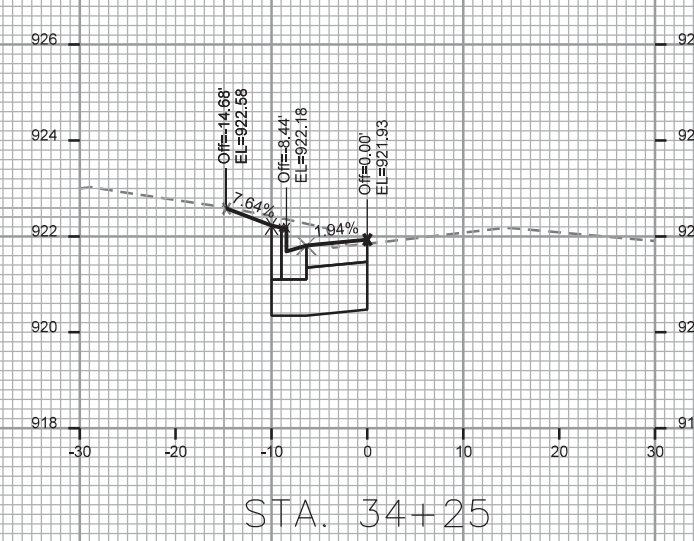
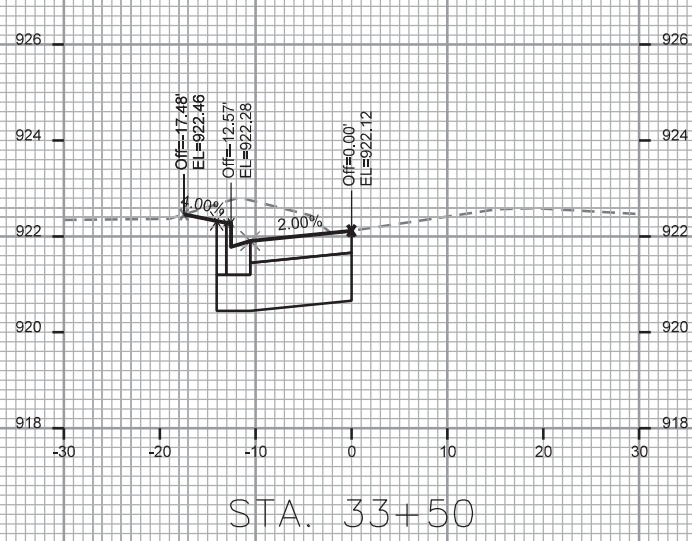
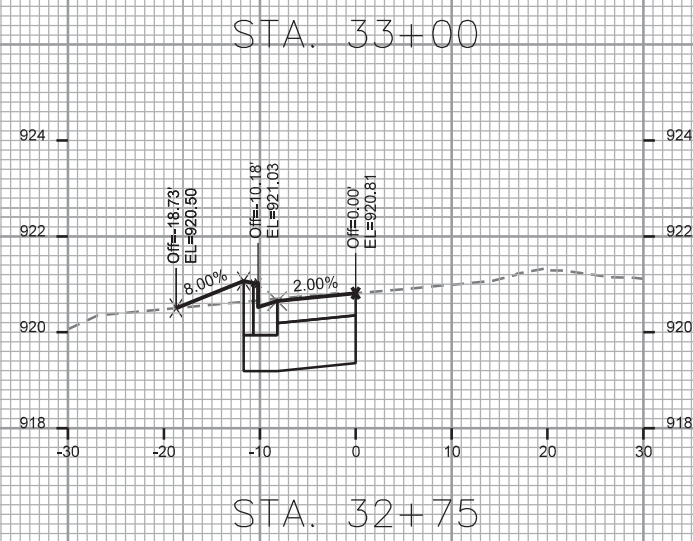
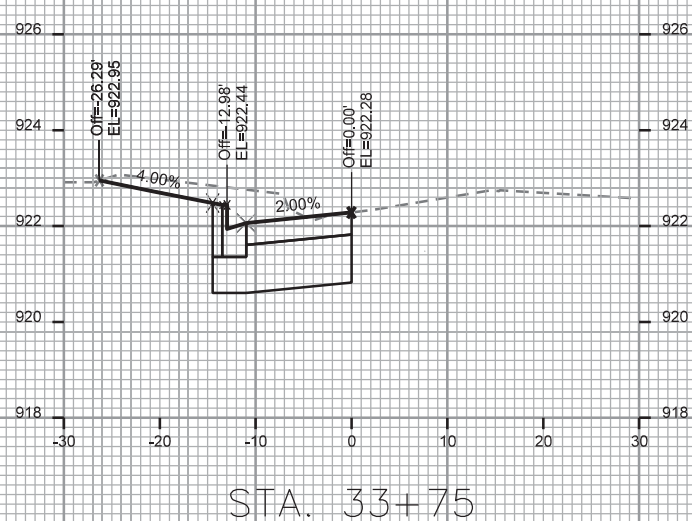
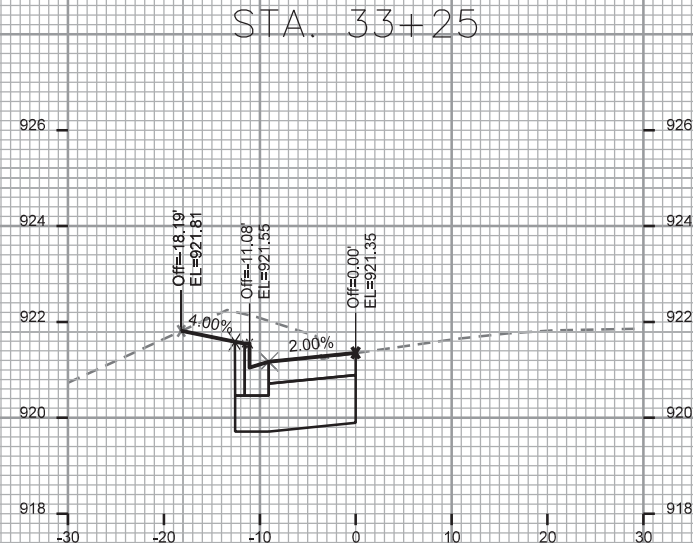
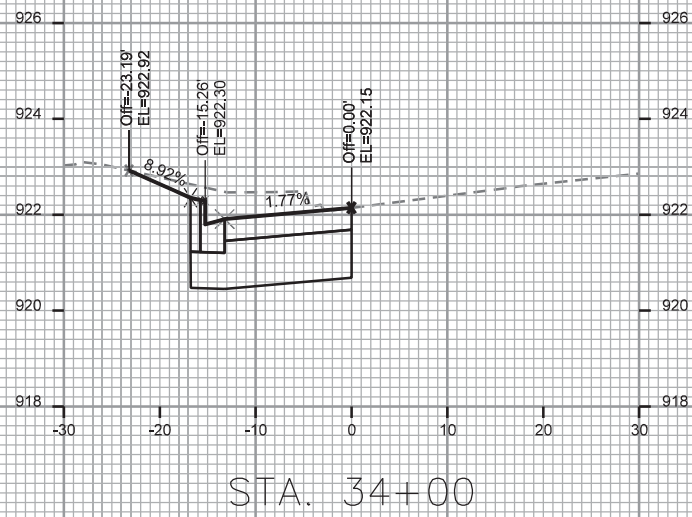
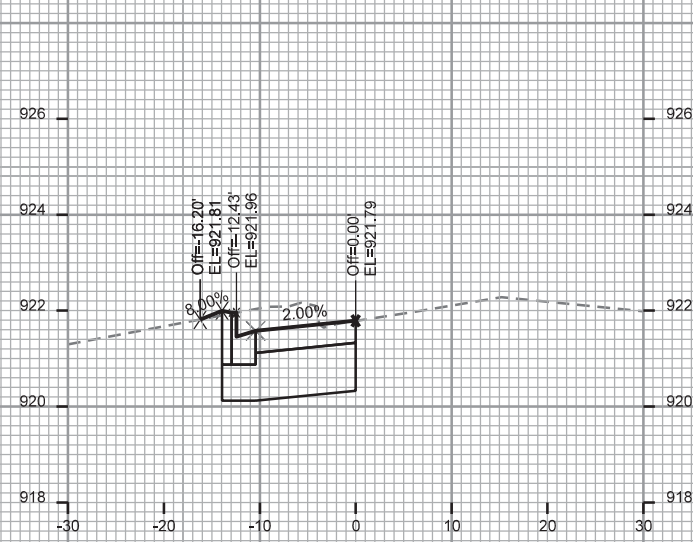

CROSS SECTIONS

HOEPKER RD/USH 51

CITY OF MADISON

PLOT SCALE: \_\_\_\_\_

PLOT NAME: \_\_\_\_\_

REV. DATE: \_\_\_\_\_

ORIGINATOR: CITY OF MADISON - STREETS DIVISION

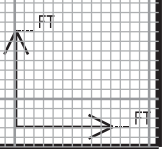
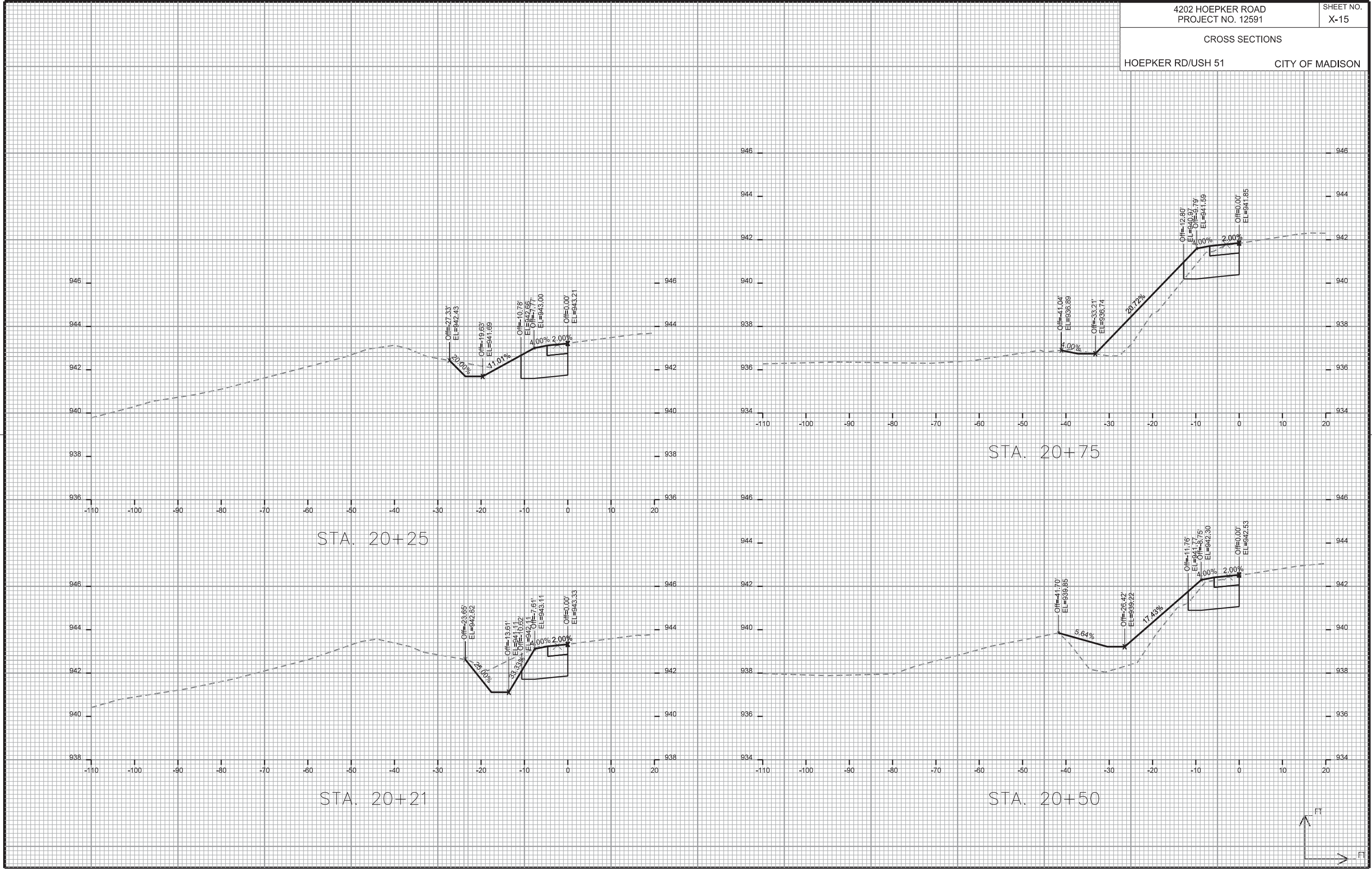



CROSS SECTIONS

HOEPKER RD/USH 51

CITY OF MADISON

PLOT SCALE: \_\_\_\_\_

PLOT NAME: \_\_\_\_\_

REV. DATE: \_\_\_\_\_

ORIGINATOR: CITY OF MADISON - STREETS DIVISION

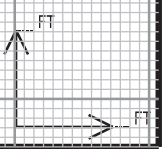
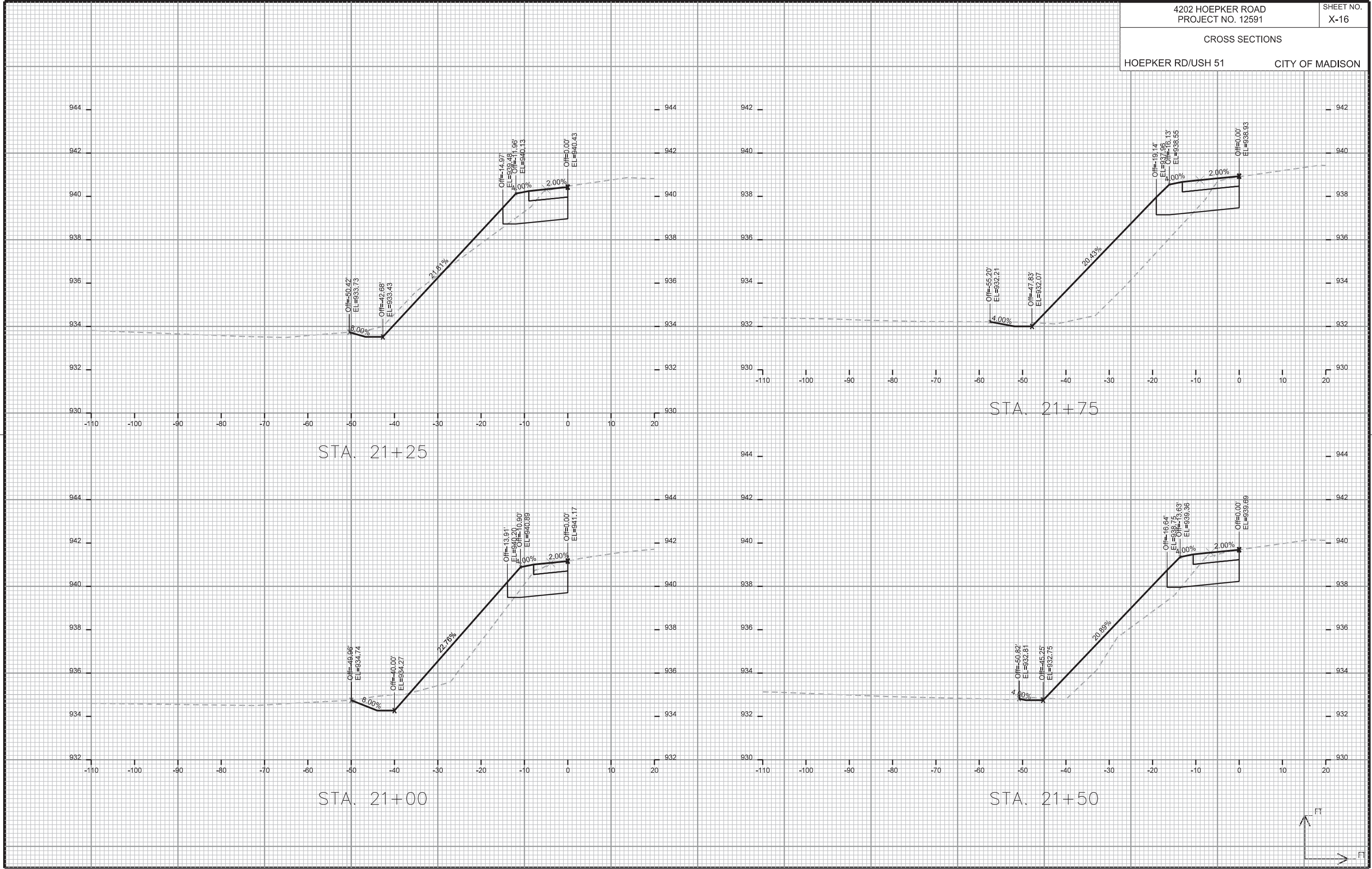

CROSS SECTIONS

HOEPKER RD/USH 51

CITY OF MADISON

PLOT SCALE: \_\_\_\_\_  
PLOT NAME: \_\_\_\_\_

REV. DATE: \_\_\_\_\_

ORIGINATOR: CITY OF MADISON, STREETS DIVISION

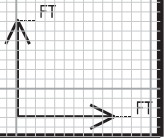
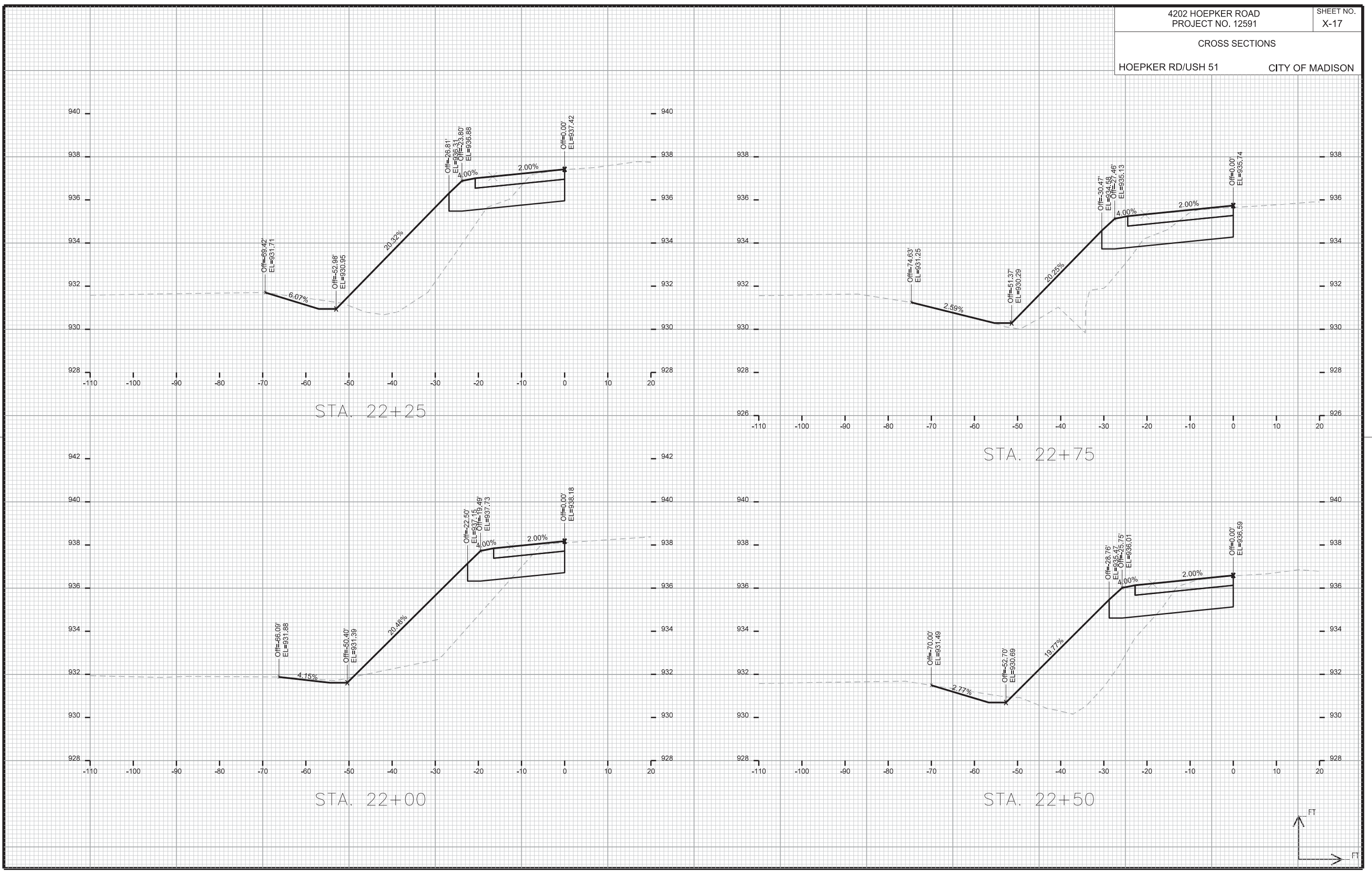

CROSS SECTIONS

HOEPKER RD/USH 51

CITY OF MADISON

PLOT SCALE: \_\_\_\_\_

PLOT NAME: \_\_\_\_\_

REV. DATE: \_\_\_\_\_

ORIGINATOR: CITY OF MADISON, STREETS DIVISION

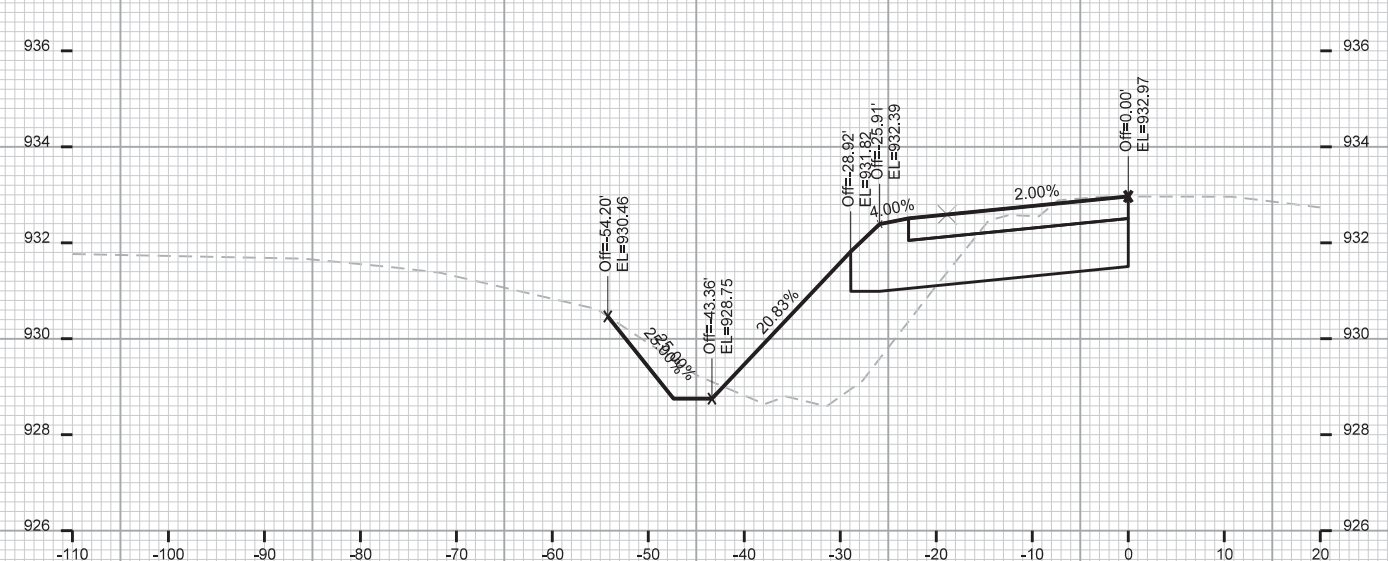
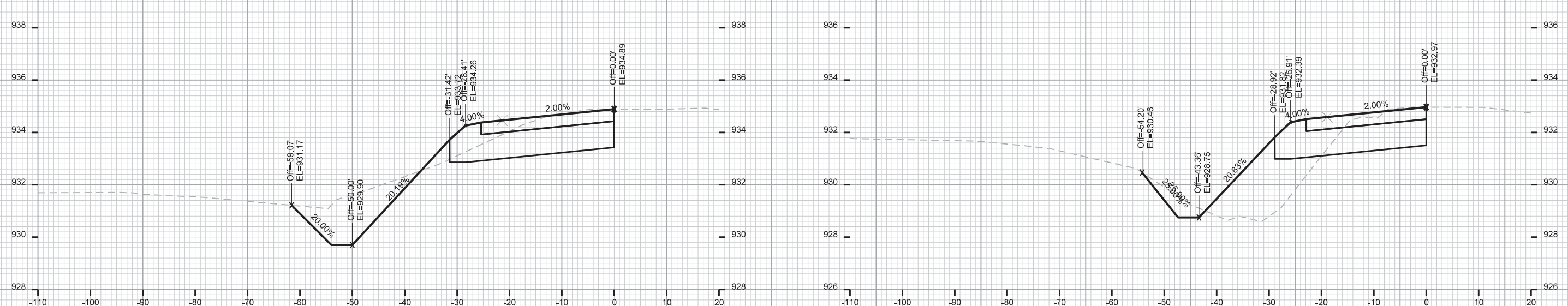
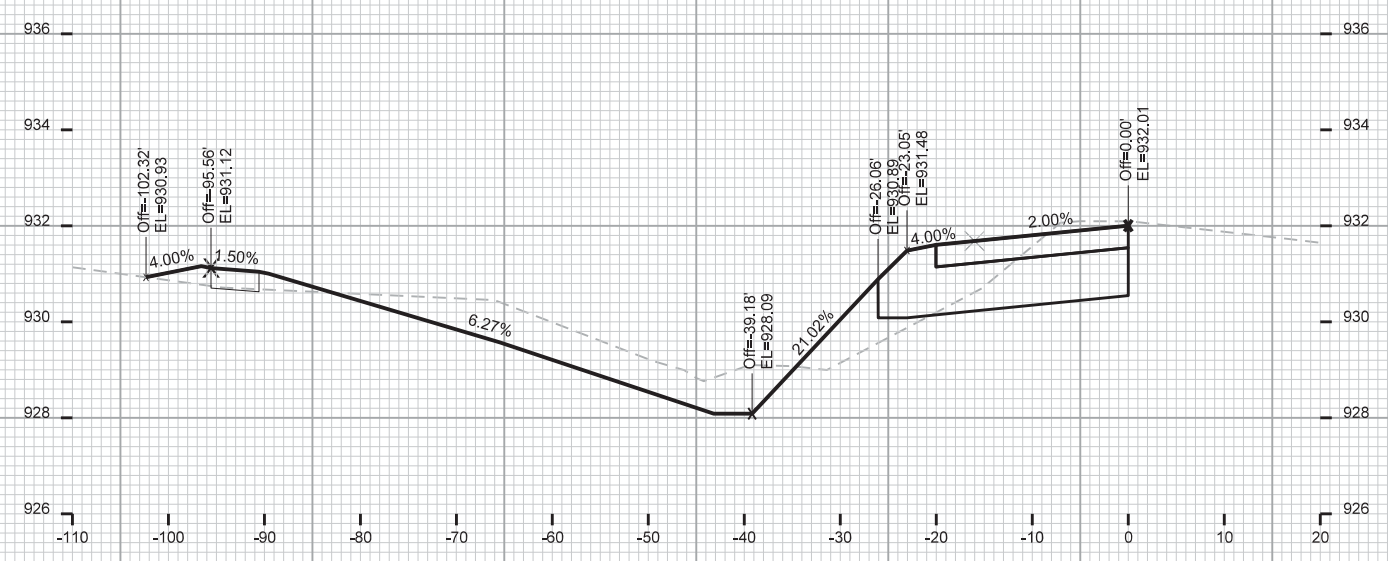
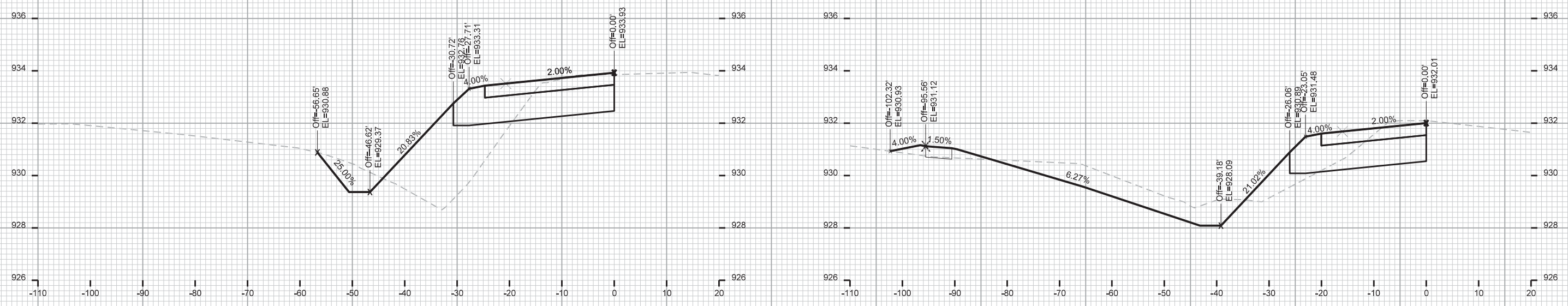

CROSS SECTIONS

HOEPKER RD/USH 51

CITY OF MADISON

PLOT SCALE: \_\_\_\_\_

PLOT NAME: \_\_\_\_\_

REV. DATE: \_\_\_\_\_

ORIGINATOR: CITY OF MADISON, STREETS DIVISION

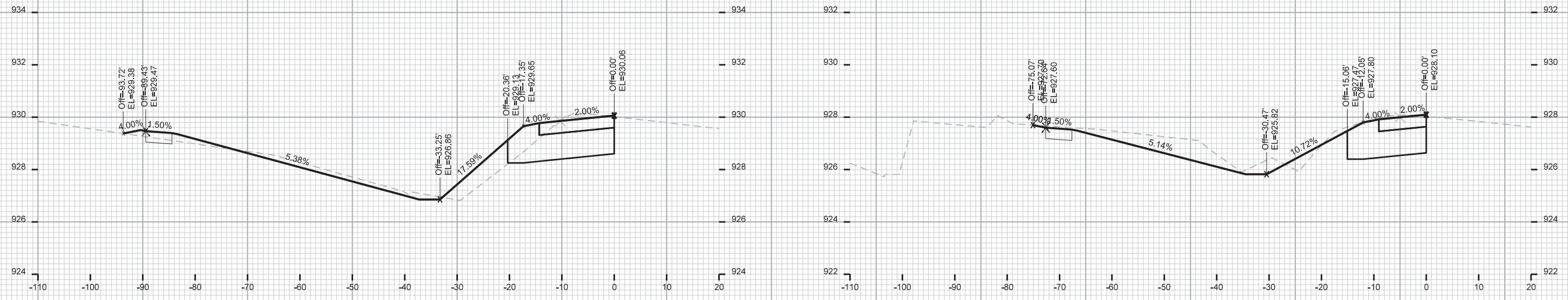

STA. 24+25

STA. 24+75

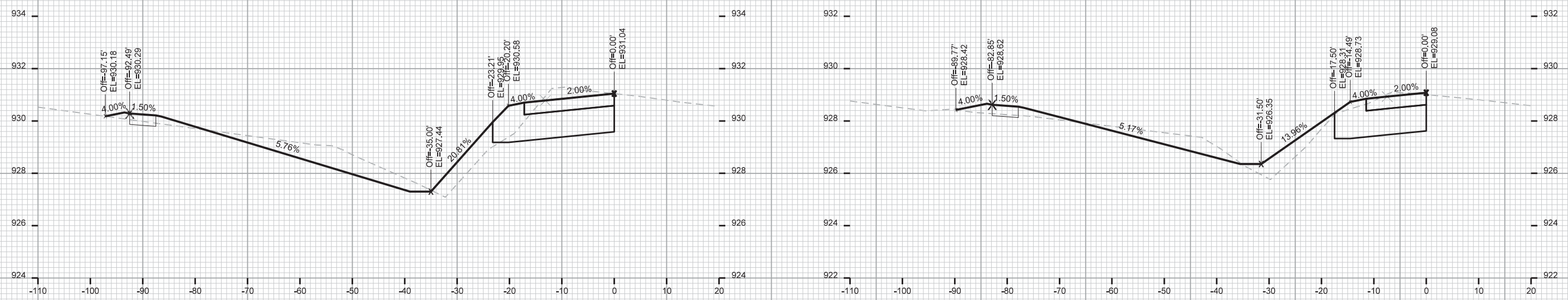

STA. 24+00

STA. 24+50

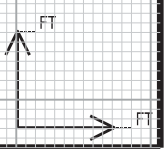

CROSS SECTIONS

HOEPKER RD/USH 51

CITY OF MADISON

PLOT SCALE: \_\_\_\_\_

PLOT NAME: \_\_\_\_\_

REV. DATE: \_\_\_\_\_

ORIGINATOR: CITY OF MADISON, STREETS DIVISION

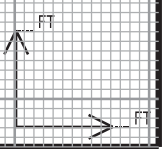
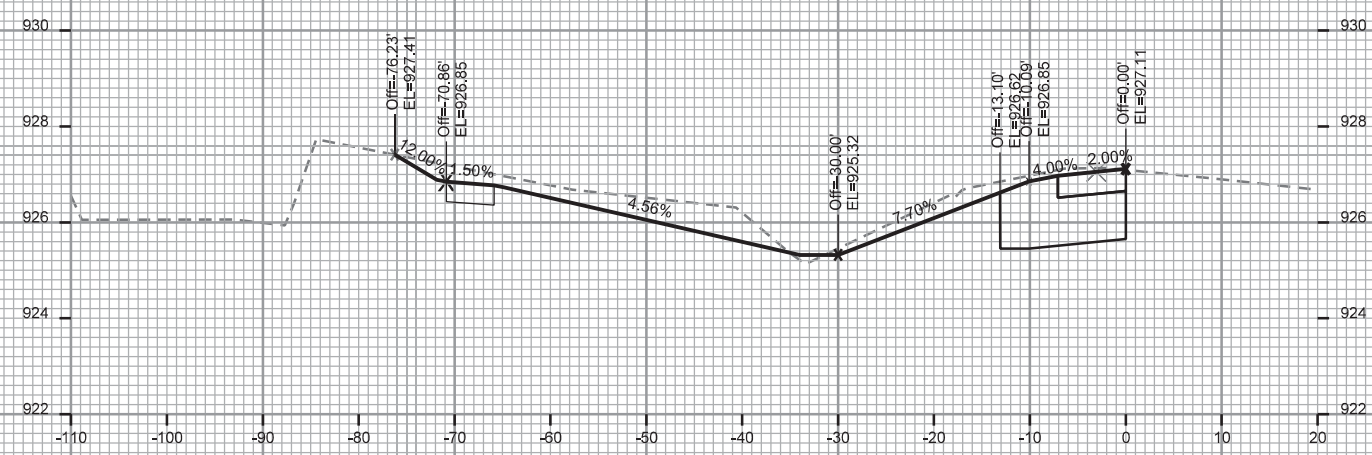
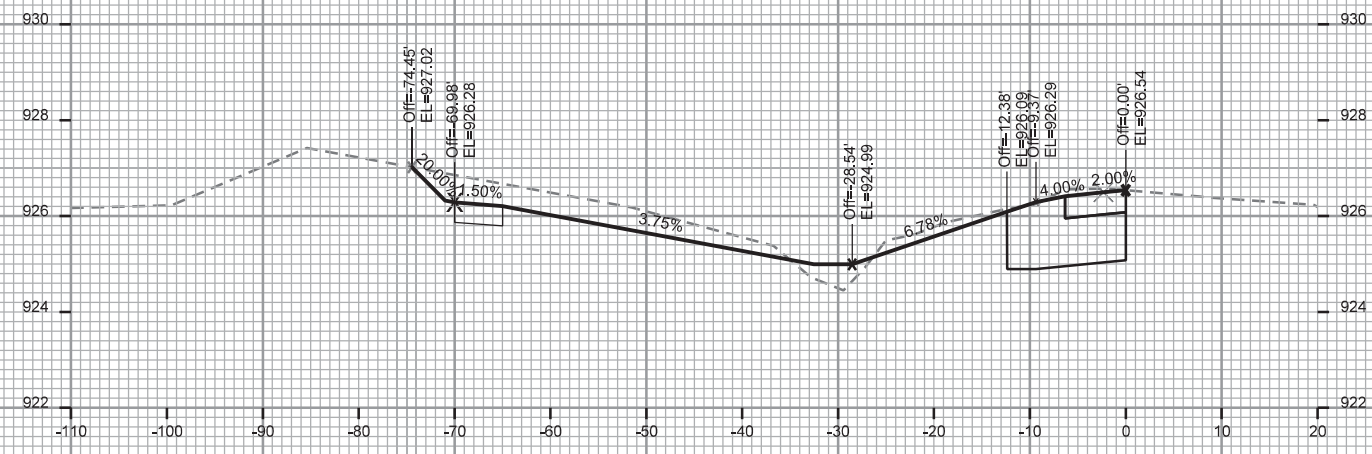

CROSS SECTIONS  
HOEPKER RD/  
MANUFACTURERS RD CITY OF MADISON

PLOT SCALE: \_\_\_\_\_

PLOT NAME: \_\_\_\_\_

REV. DATE: \_\_\_\_\_

ORIGINATOR: CITY OF MADISON STREETS DIVISION

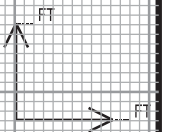
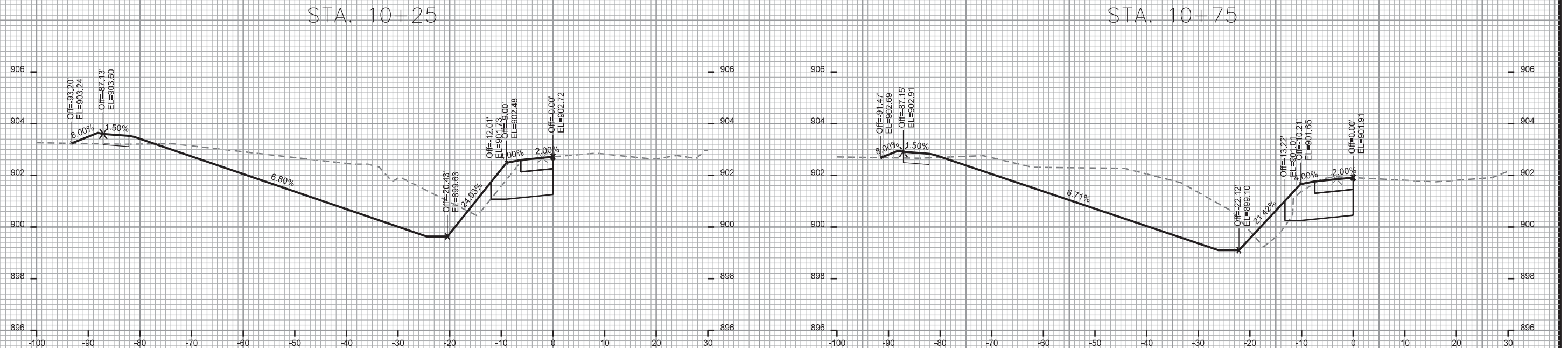
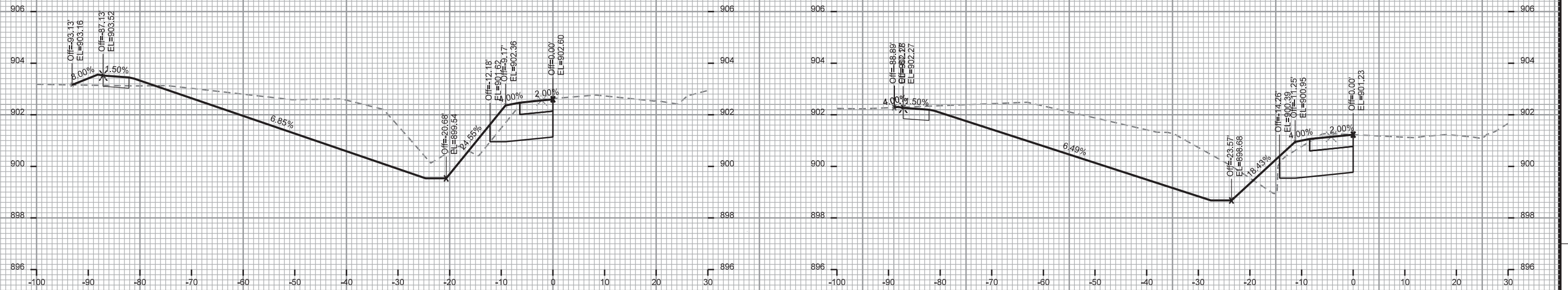

CROSS SECTIONS

HOEPKER RD/  
MANUFACTURERS RD CITY OF MADISON

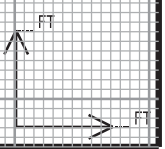
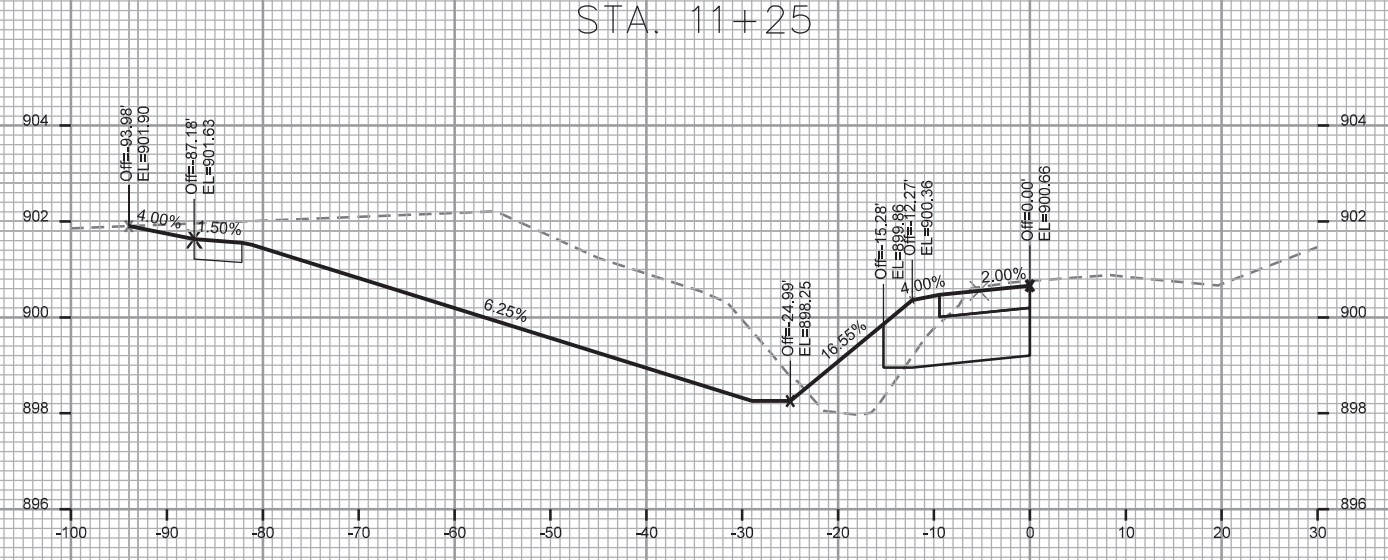
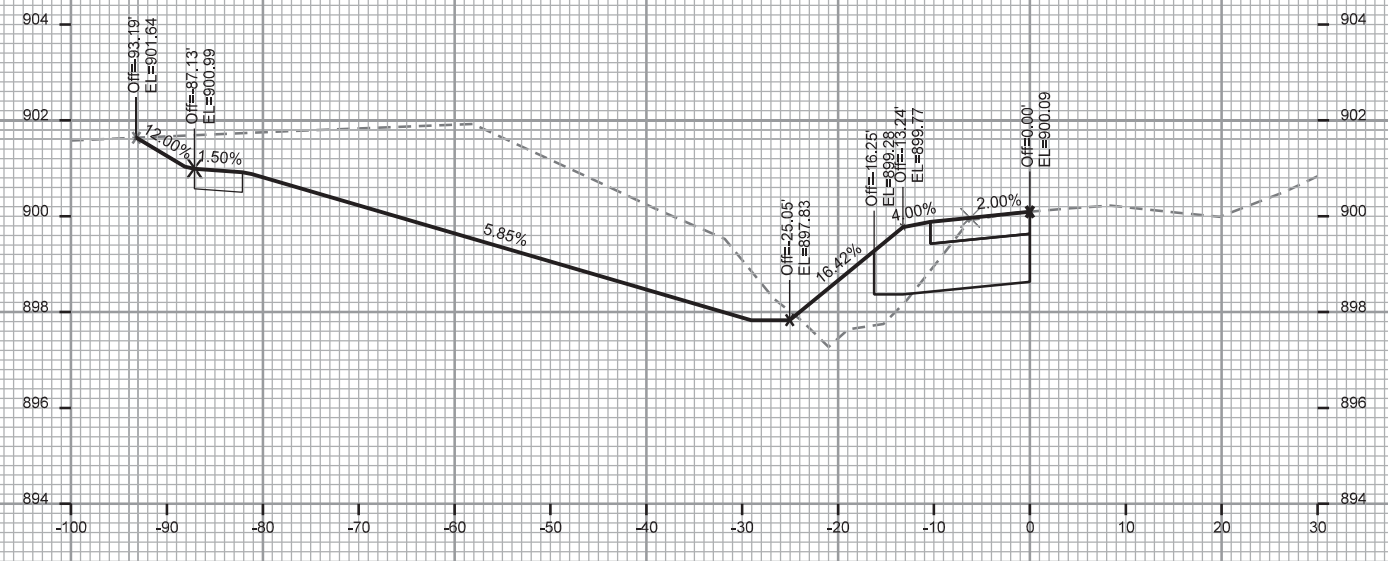
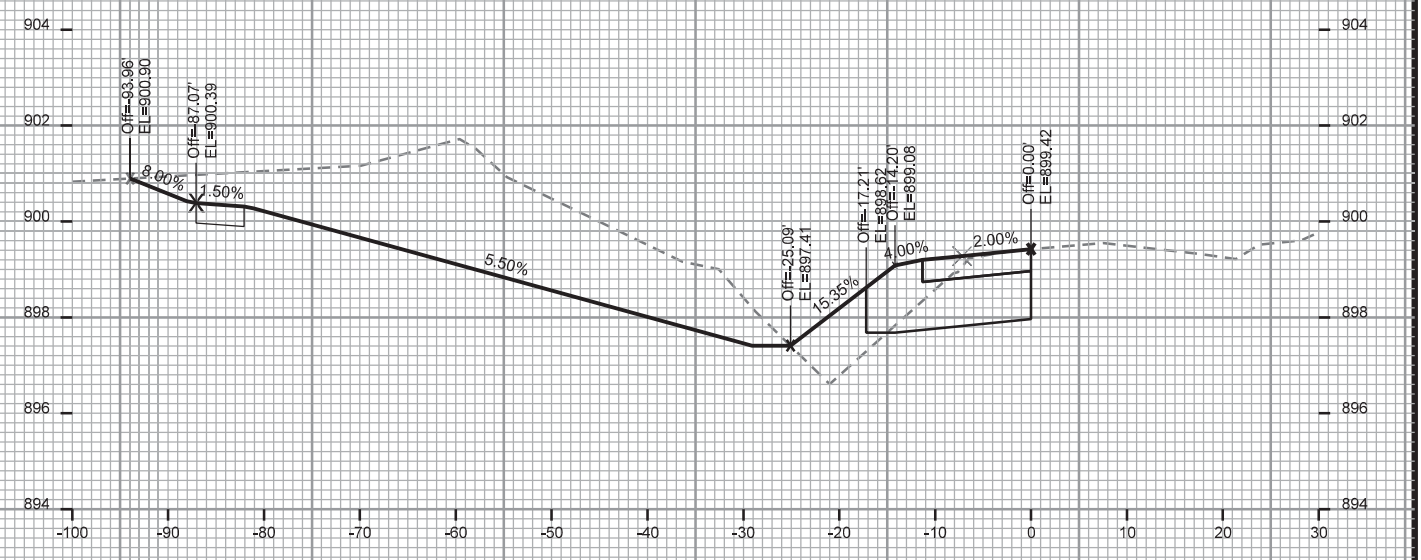
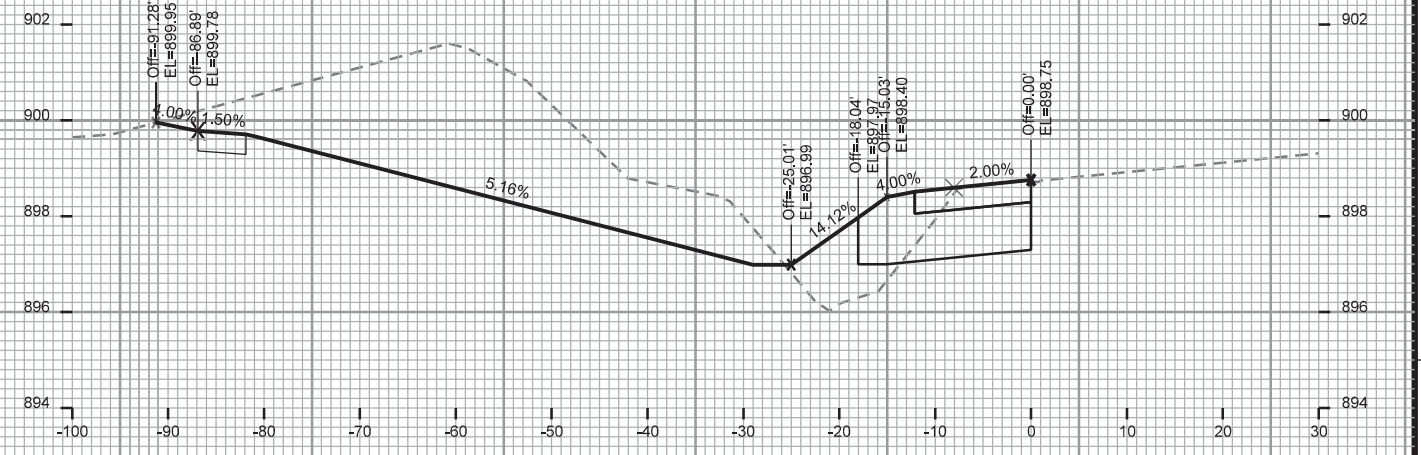
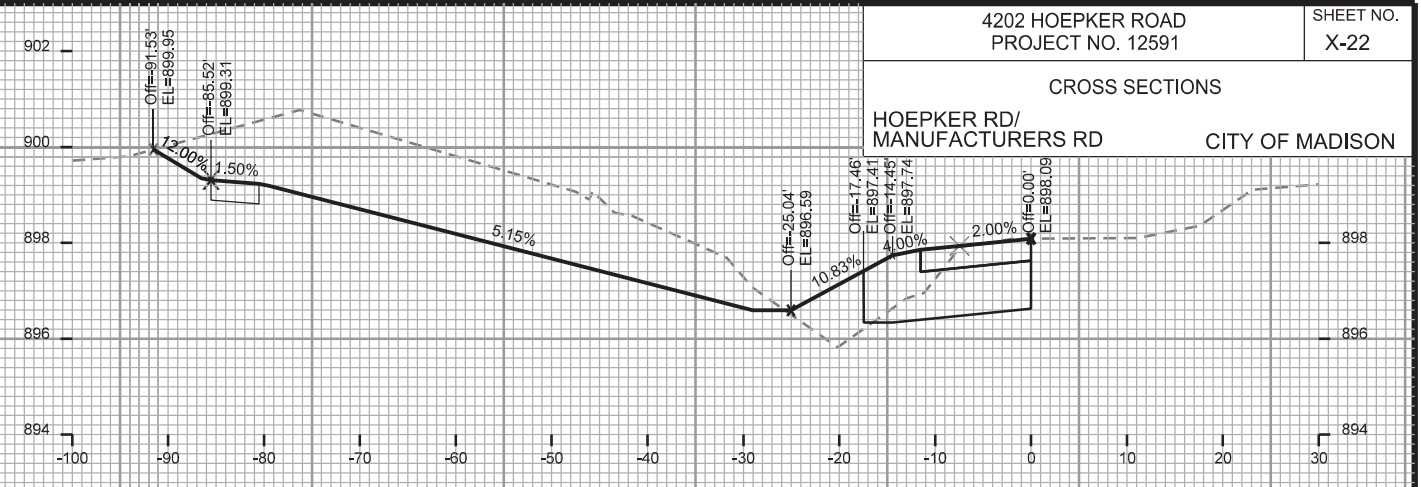

PLOT SCALE: \_\_\_\_\_

PLOT NAME: \_\_\_\_\_

REV. DATE: \_\_\_\_\_

ORIGINATOR: CITY OF MADISON - STREETS DIVISION

CROSS SECTIONS  
HOEPKER RD/  
MANUFACTURERS RD CITY OF MADISON

PLOT SCALE: \_\_\_\_\_

PLOT NAME: \_\_\_\_\_

REV. DATE: \_\_\_\_\_

ORIGINATOR: CITY OF MADISON STREETS DIVISION

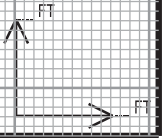
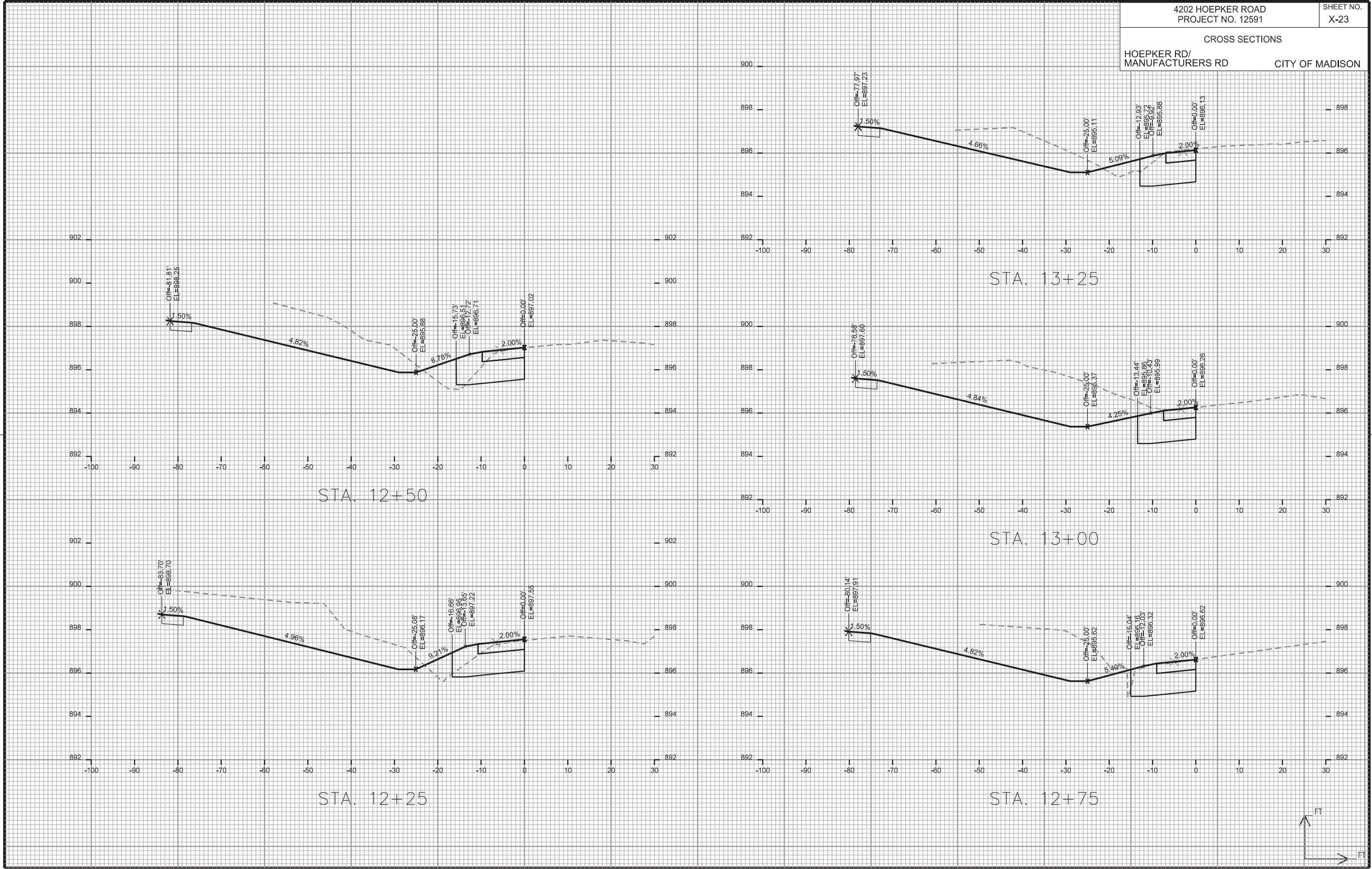



CROSS SECTIONS  
HOEPKER RD/  
MANUFACTURERS RD CITY OF MADISON

PLOT SCALE: \_\_\_\_\_

PLOT NAME: \_\_\_\_\_

REV. DATE: \_\_\_\_\_

ORIGINATOR: CITY OF MADISON - STREETS DIVISION

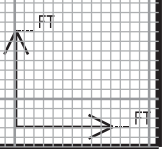
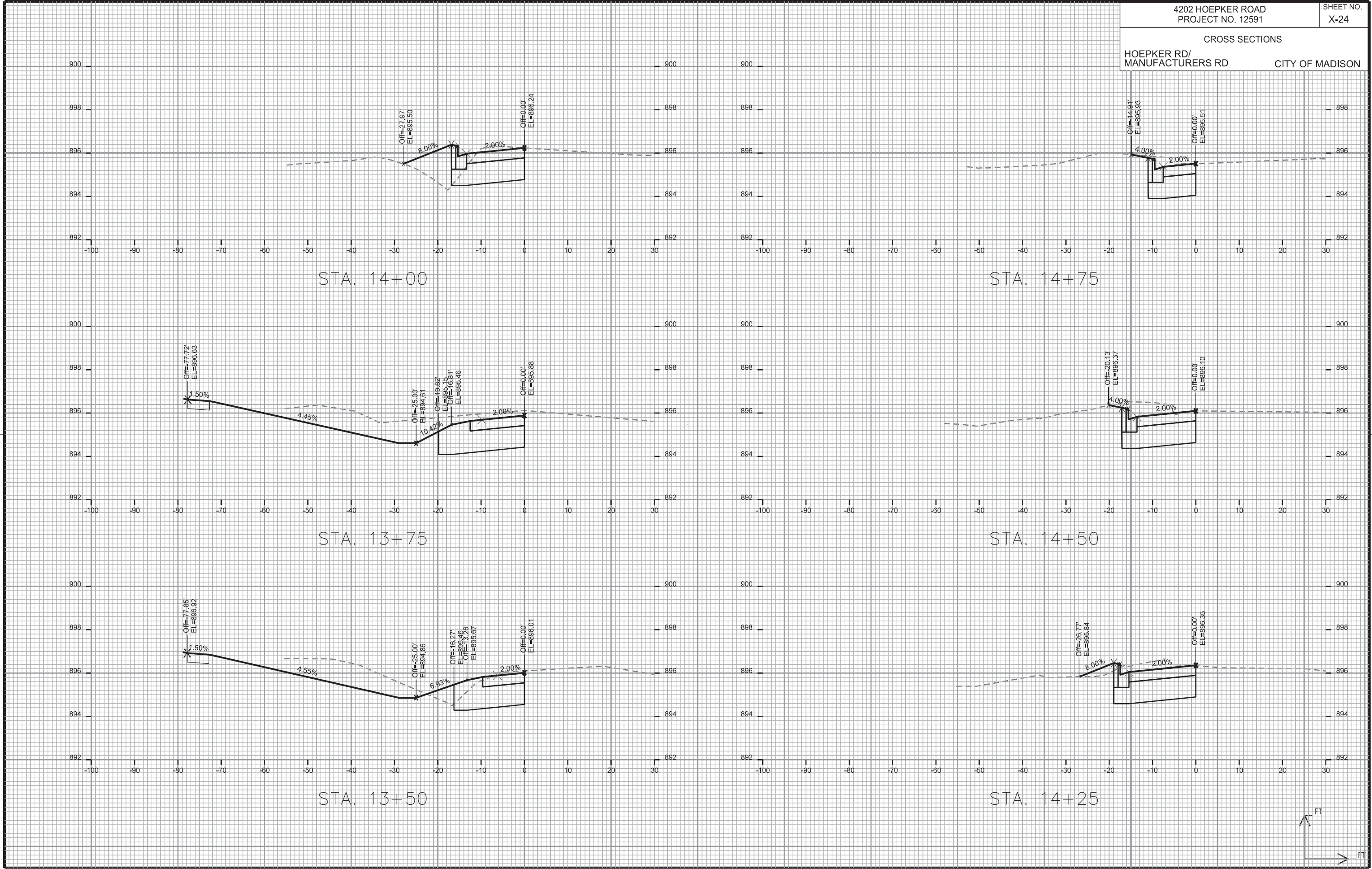

PLOT SCALE: \_\_\_\_\_

PLOT NAME: \_\_\_\_\_

REV. DATE: \_\_\_\_\_

ORIGINATOR: CITY OF MADISON - STREETS DIVISION

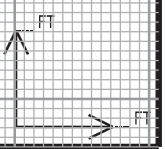
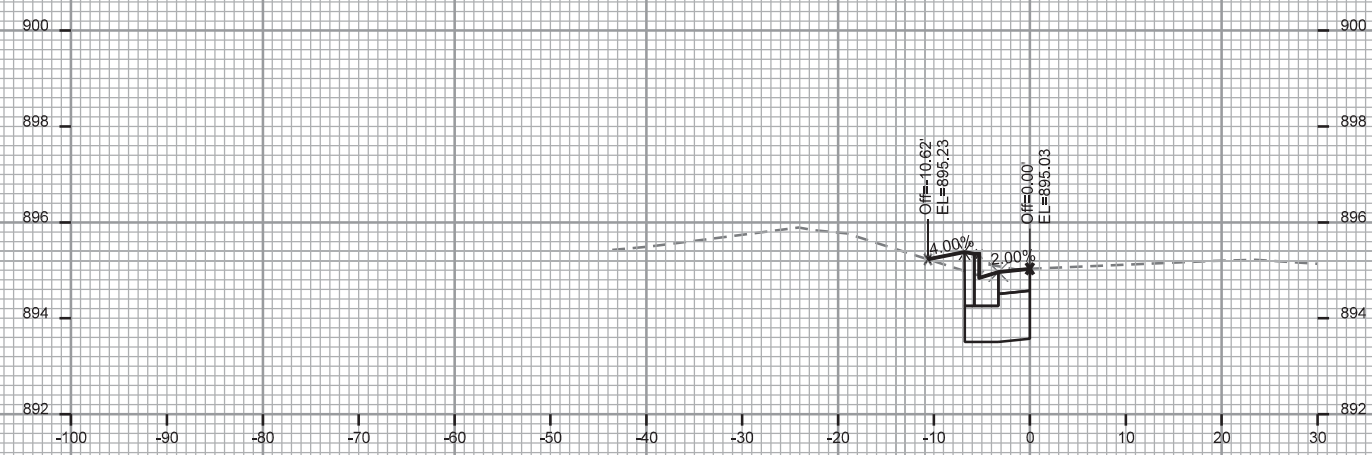
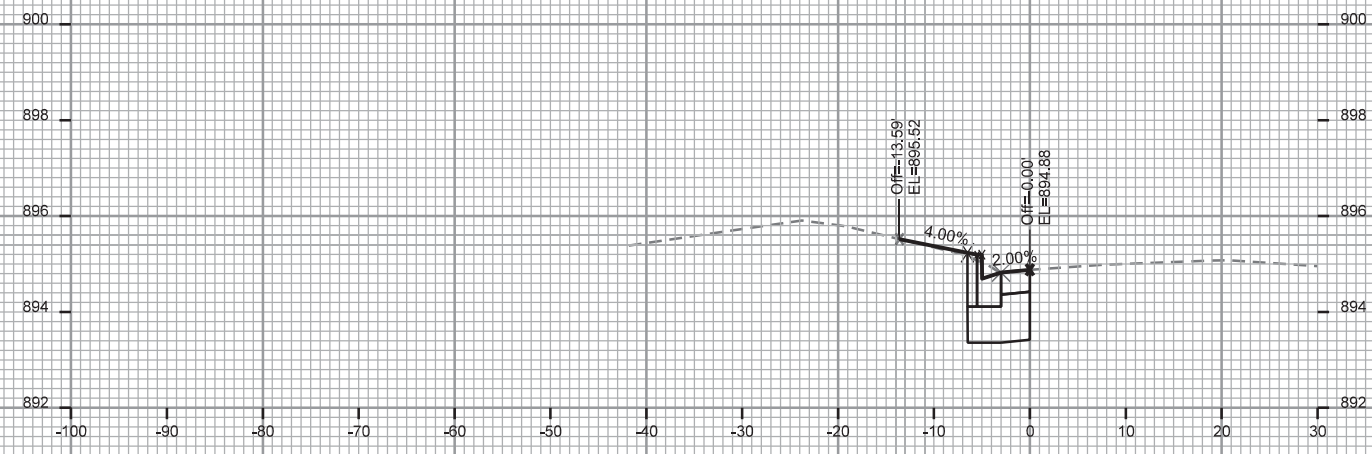

CROSS SECTIONS  
HOEPKER RD SIDEWALK CITY OF MADISON

PLOT SCALE: \_\_\_\_\_

PLOT NAME: \_\_\_\_\_

REV. DATE: \_\_\_\_\_

ORIGINATOR: CITY OF MADISON, STREETS DIVISION

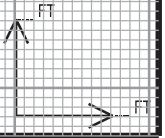
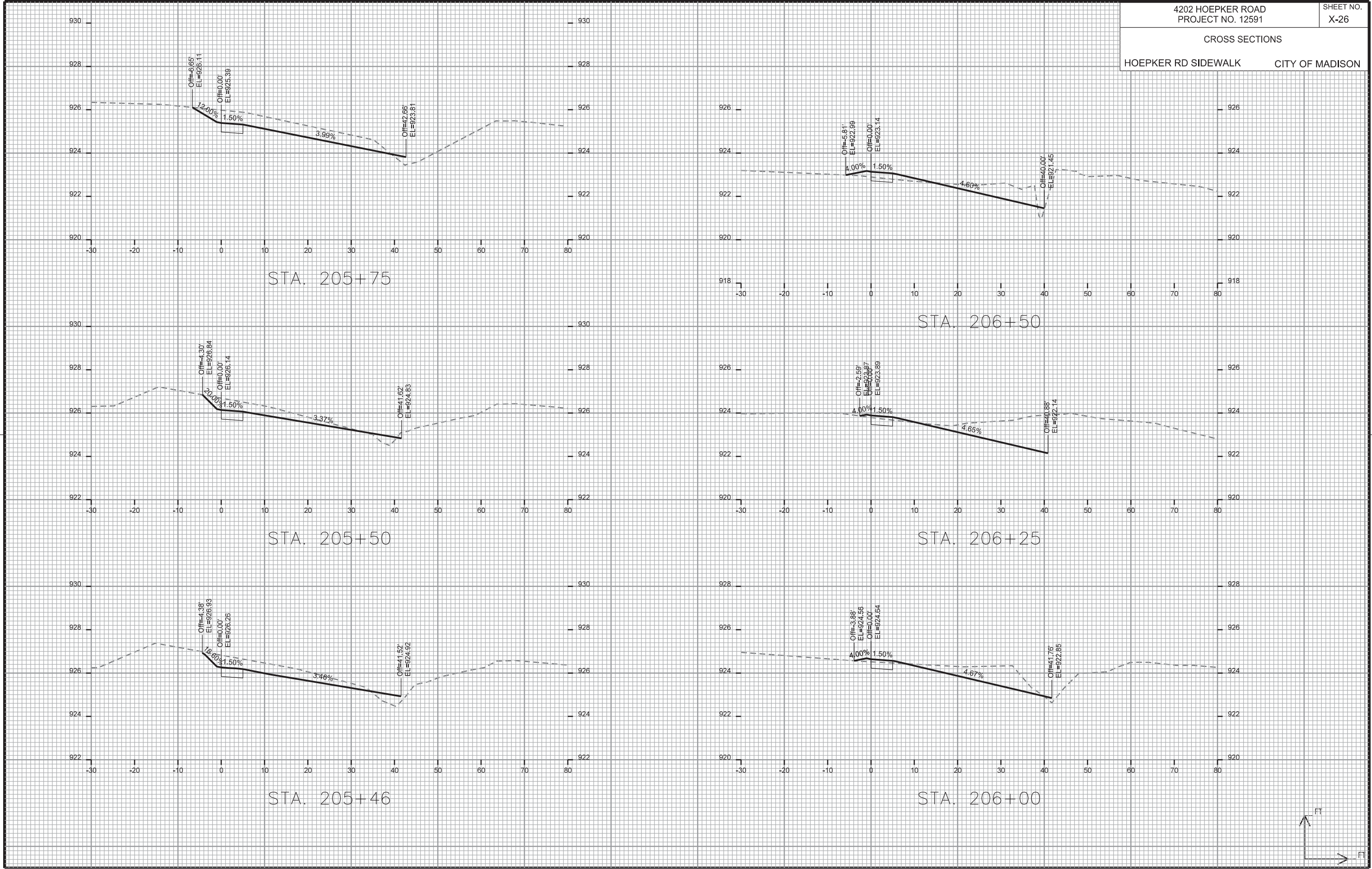

CROSS SECTIONS

HOEPKER RD SIDEWALK

CITY OF MADISON

PLOT SCALE: \_\_\_\_\_

PLOT NAME: \_\_\_\_\_

REV. DATE: \_\_\_\_\_

ORIGINATOR: CITY OF MADISON - STREETS DIVISION

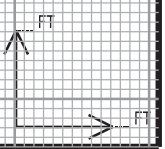
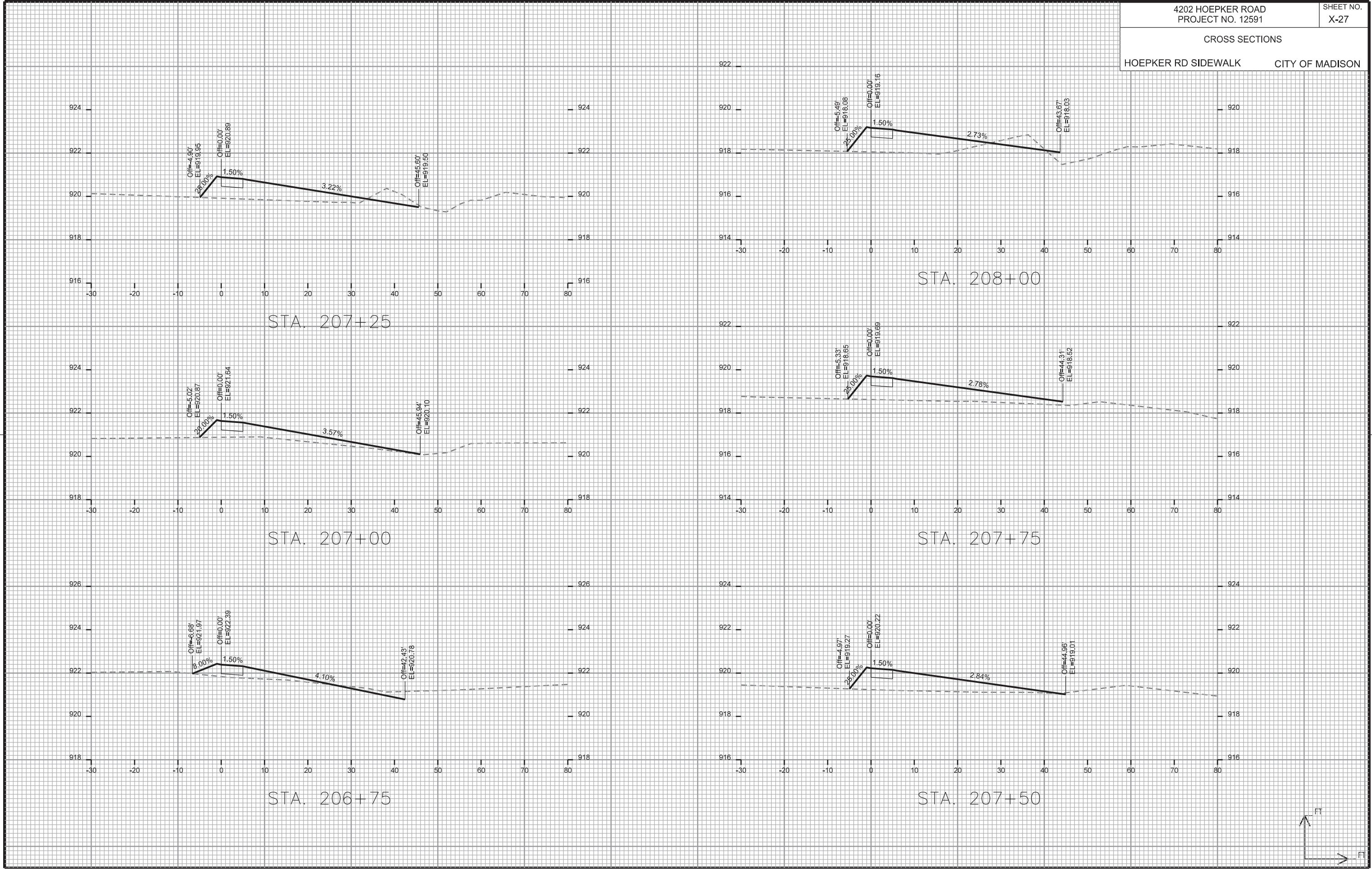

CROSS SECTIONS

HOEPKER RD SIDEWALK

CITY OF MADISON

PLOT SCALE: \_\_\_\_\_

PLOT NAME: \_\_\_\_\_

REV. DATE: \_\_\_\_\_

ORIGINATOR: CITY OF MADISON - STREETS DIVISION

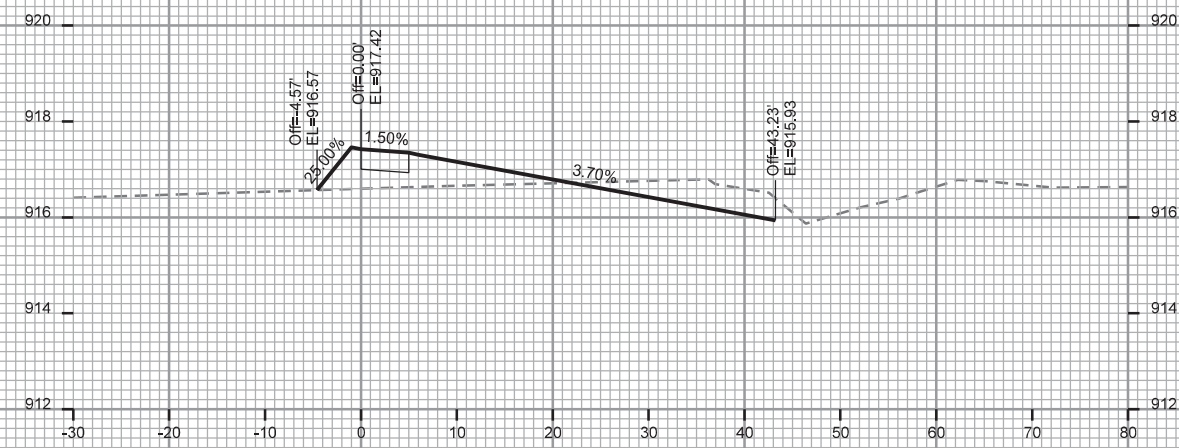
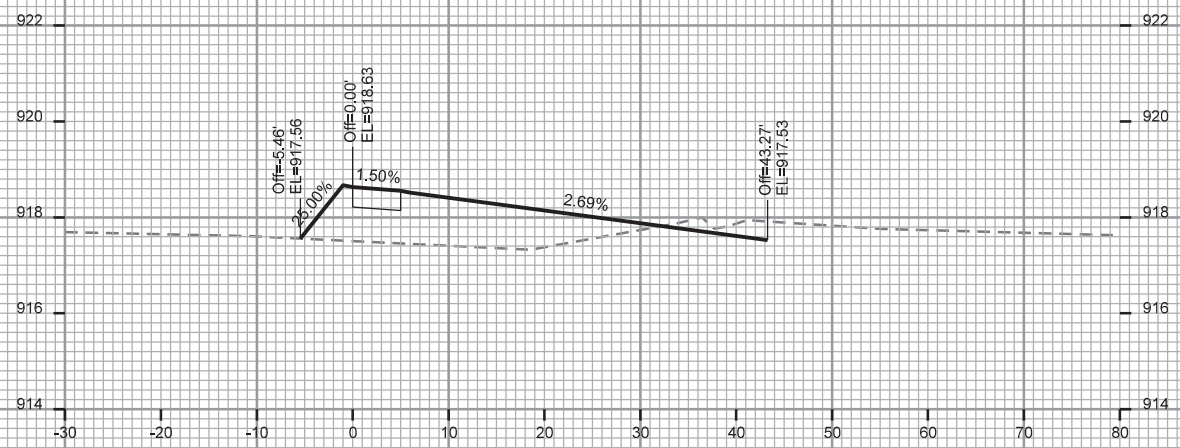
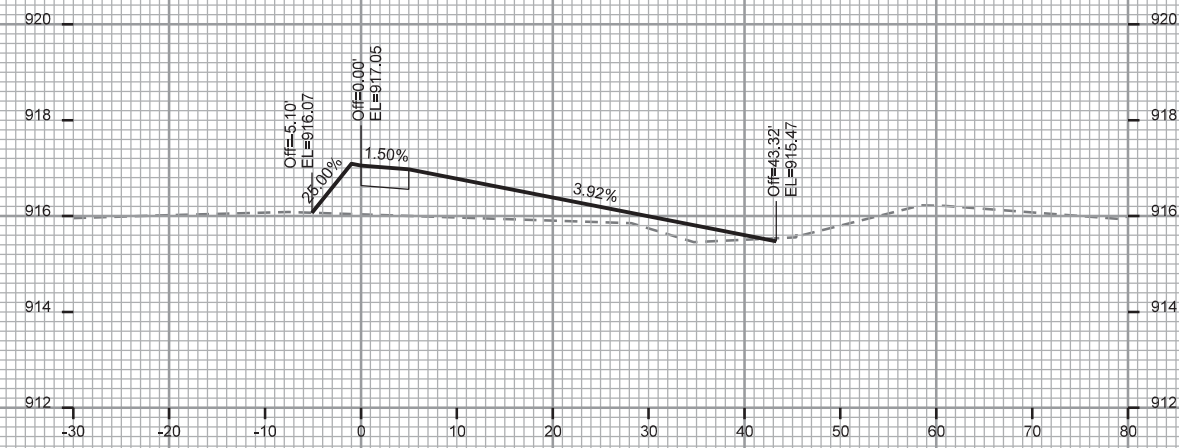
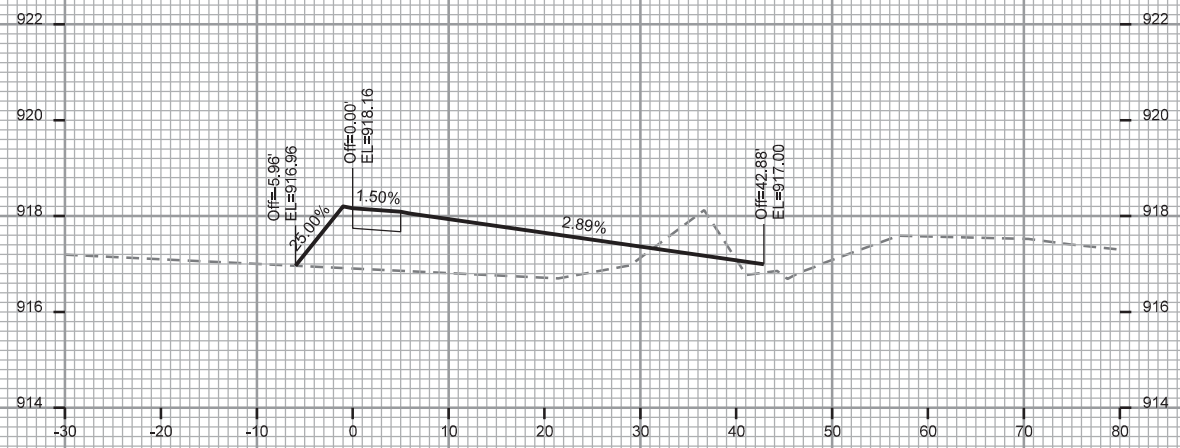
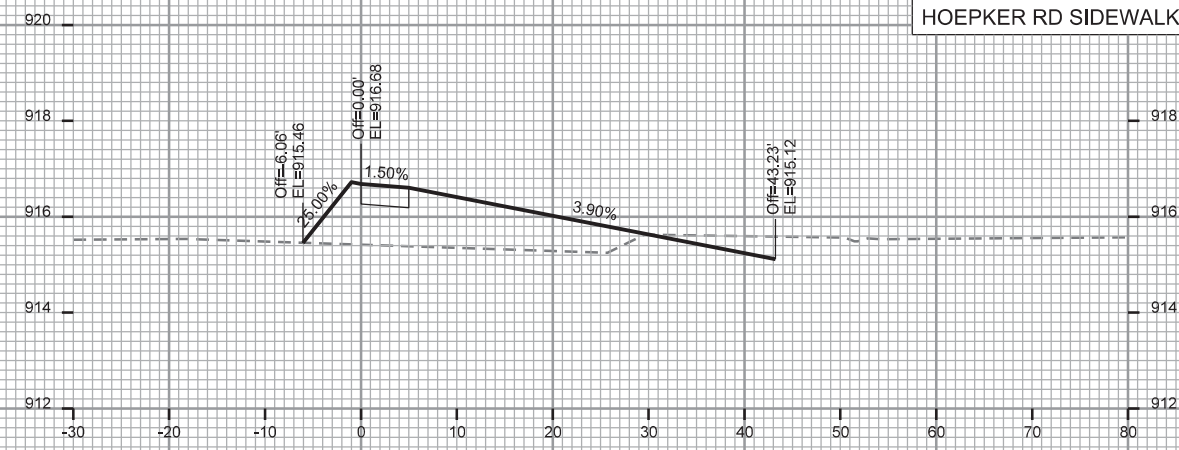
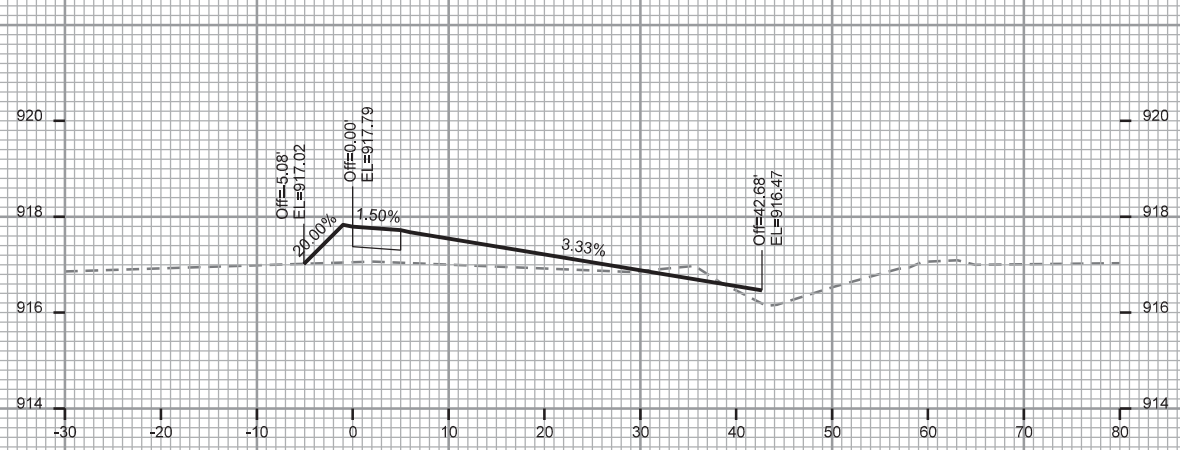

CROSS SECTIONS

HOEPKER RD SIDEWALK

CITY OF MADISON

PLOT SCALE: \_\_\_\_\_

PLOT NAME: \_\_\_\_\_

REV. DATE: \_\_\_\_\_

ORIGINATOR: CITY OF MADISON, STREETS DIVISION

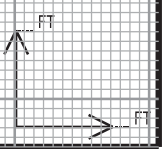
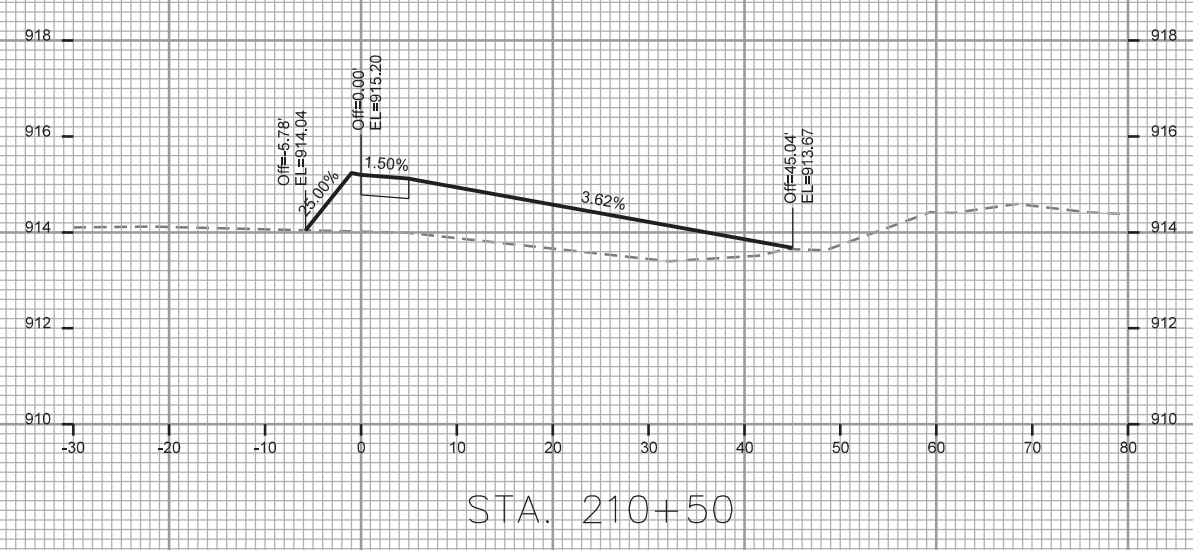
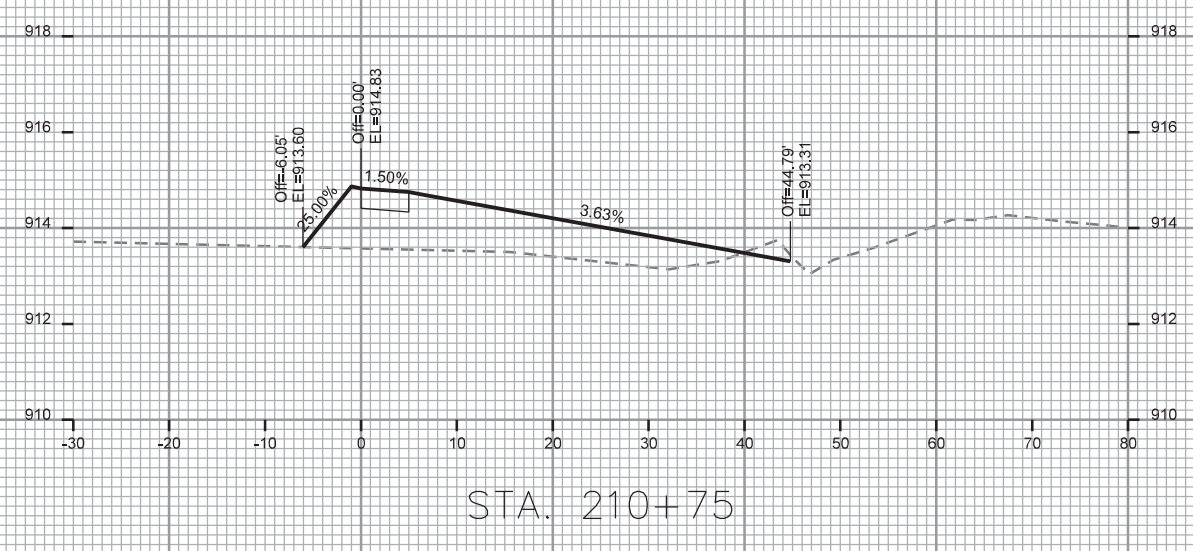
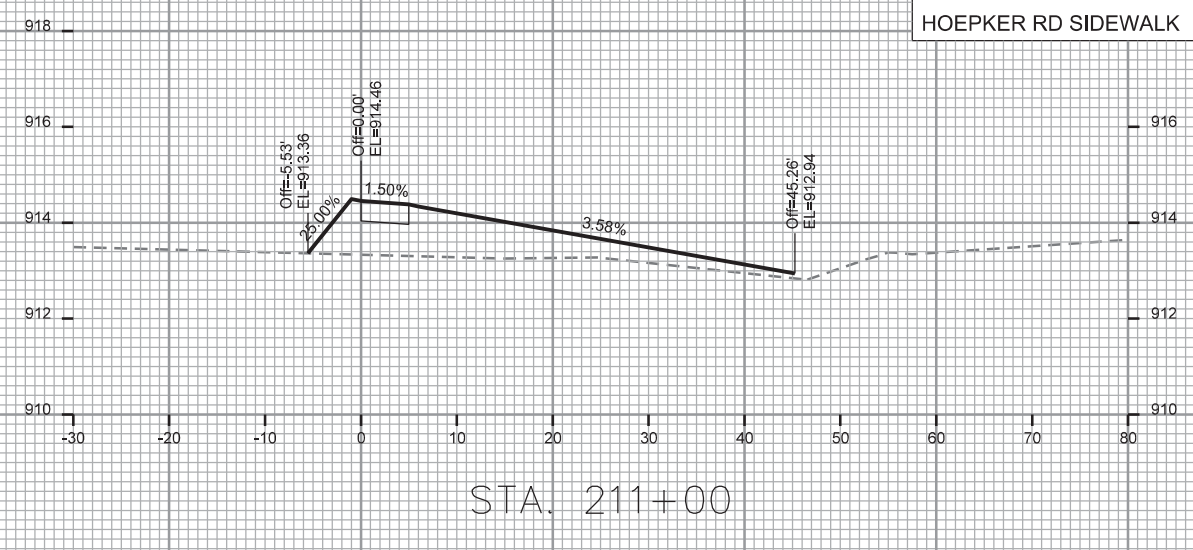
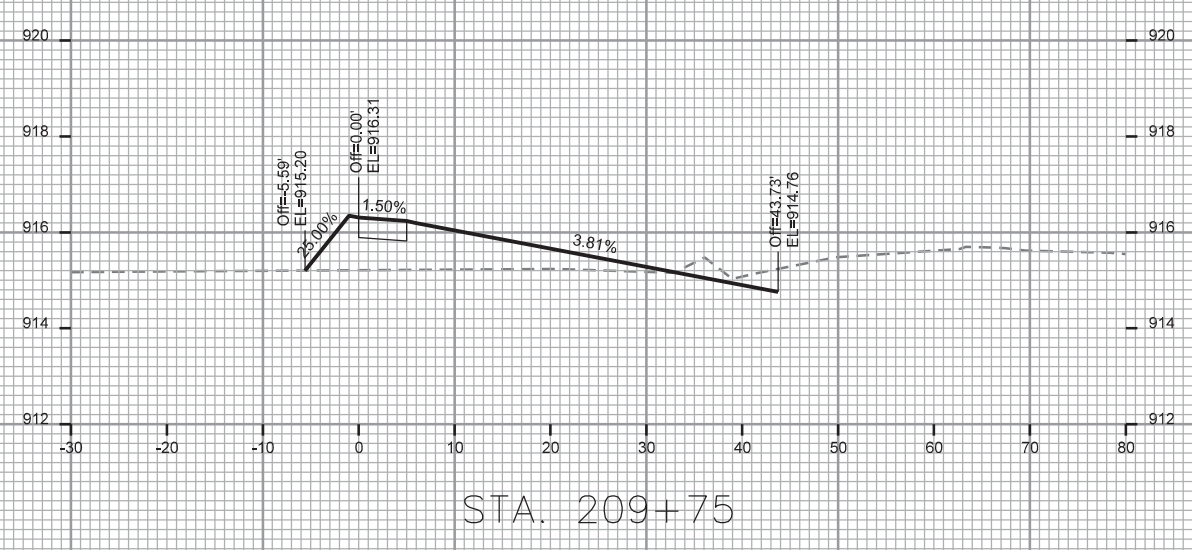
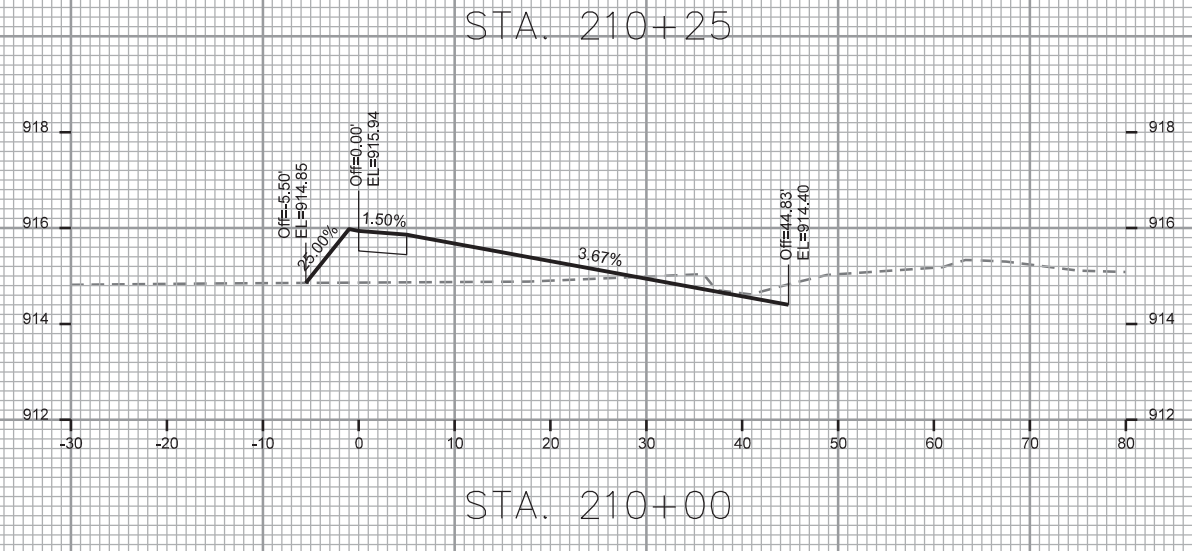
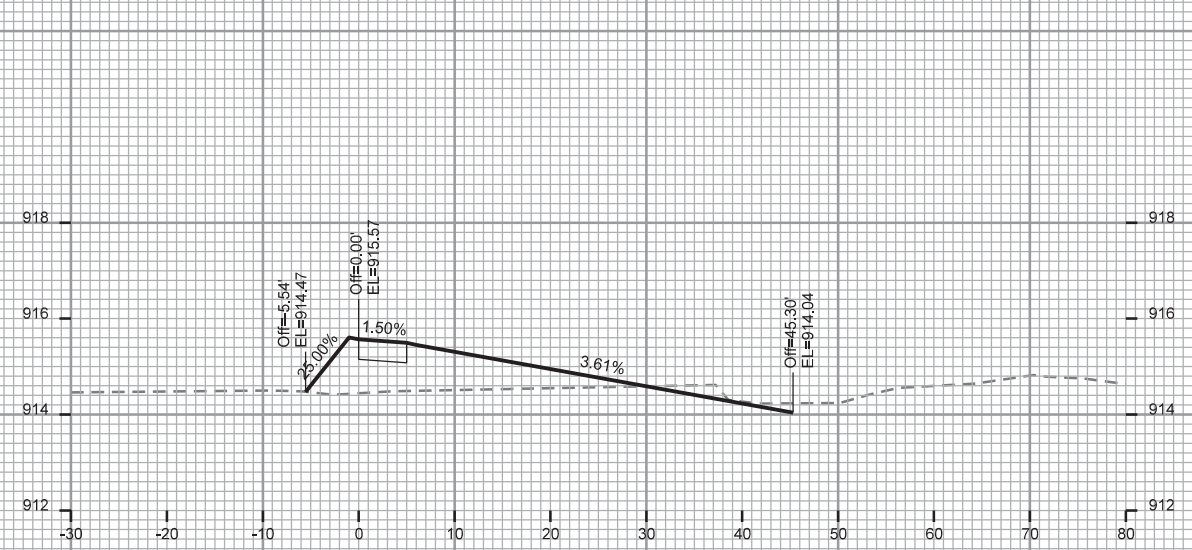

CROSS SECTIONS  
HOEPKER RD SIDEWALK CITY OF MADISON

PLOT SCALE: \_\_\_\_\_

PLOT NAME: \_\_\_\_\_

REV. DATE: \_\_\_\_\_

ORIGINATOR: CITY OF MADISON - STREETS DIVISION

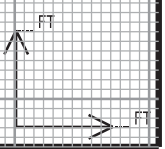
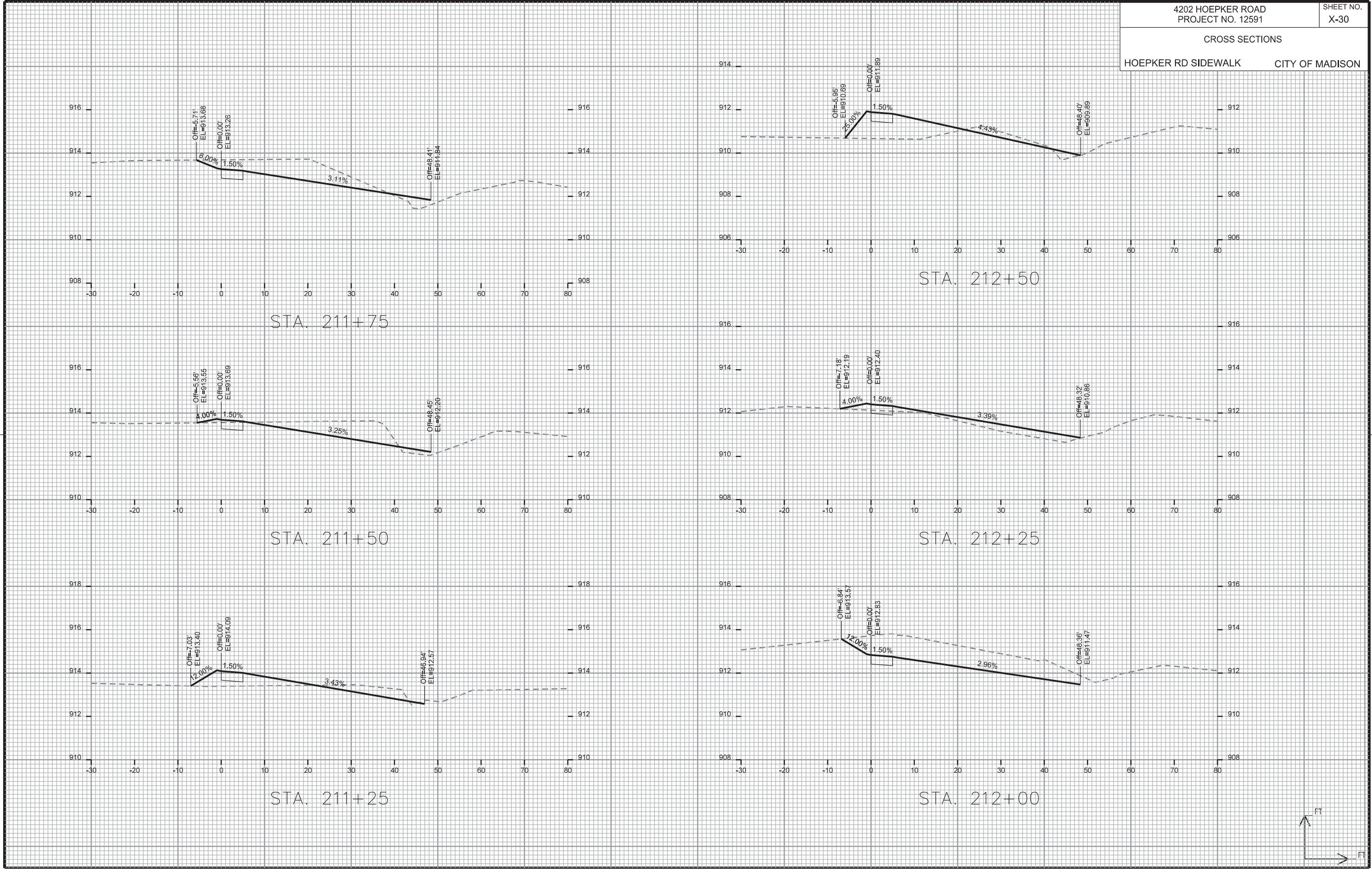

CROSS SECTIONS

HOEPKER RD SIDEWALK

CITY OF MADISON

PLOT SCALE: \_\_\_\_\_

PLOT NAME: \_\_\_\_\_

REV. DATE: \_\_\_\_\_

ORIGINATOR: CITY OF MADISON STREETS DIVISION

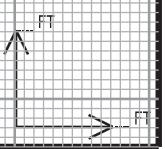
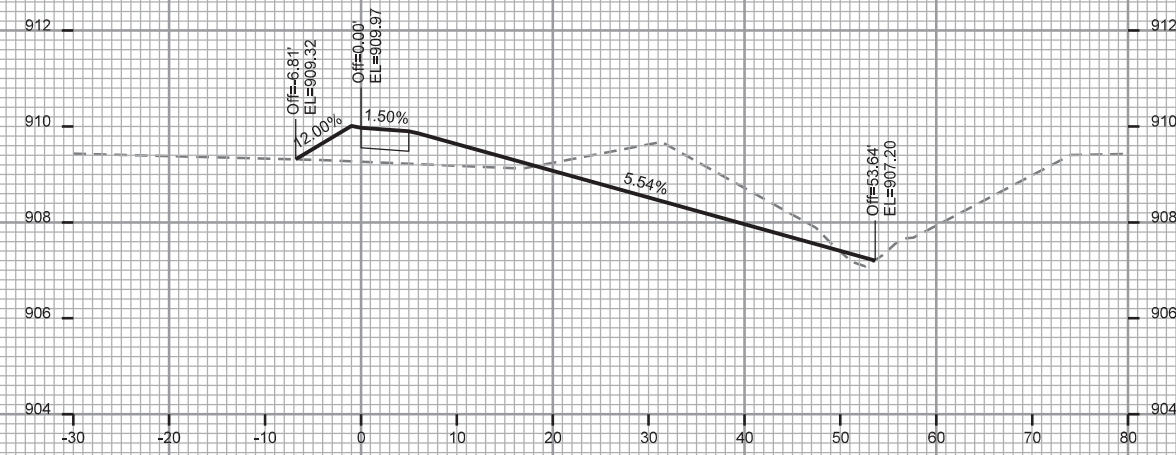
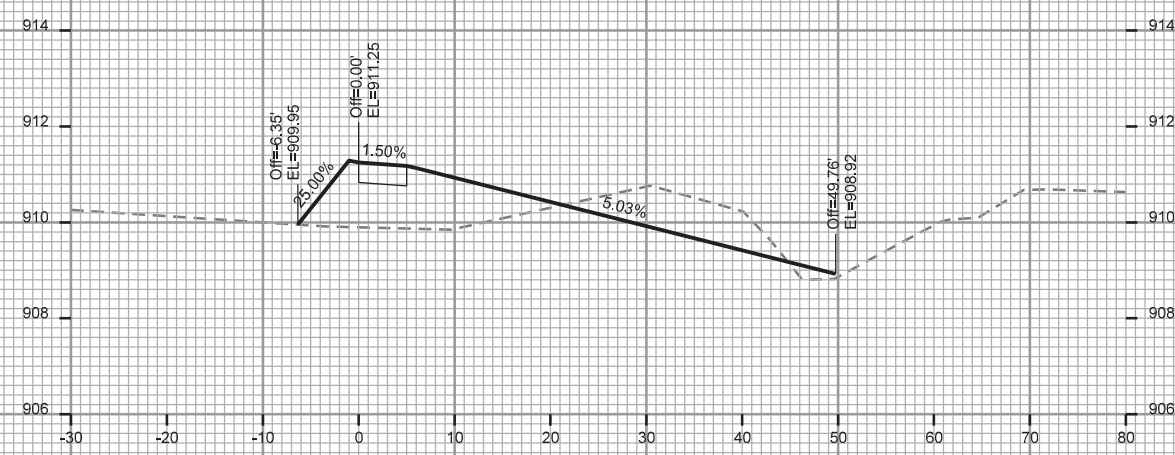
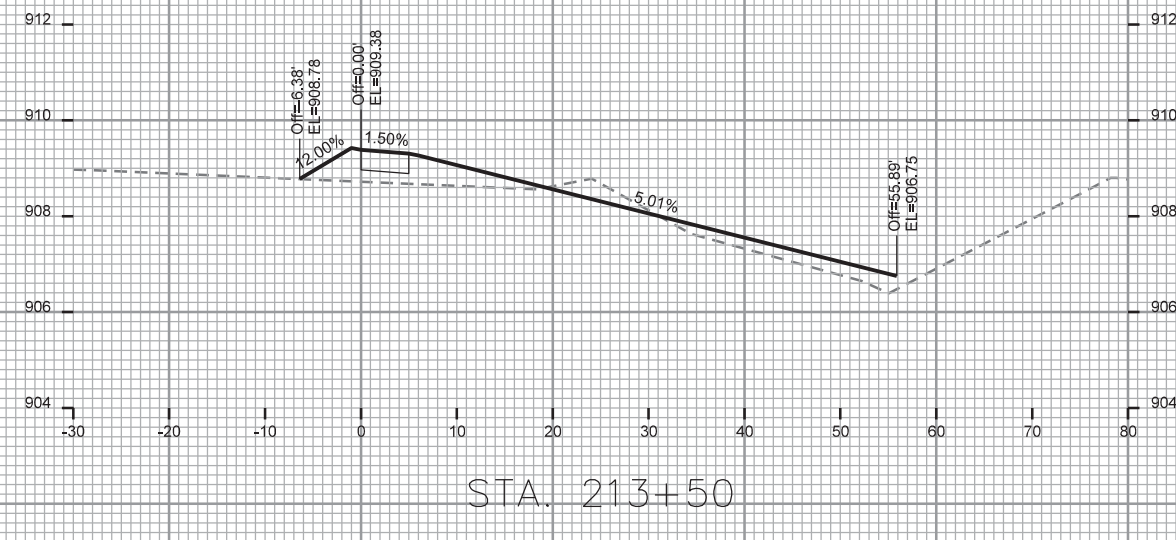
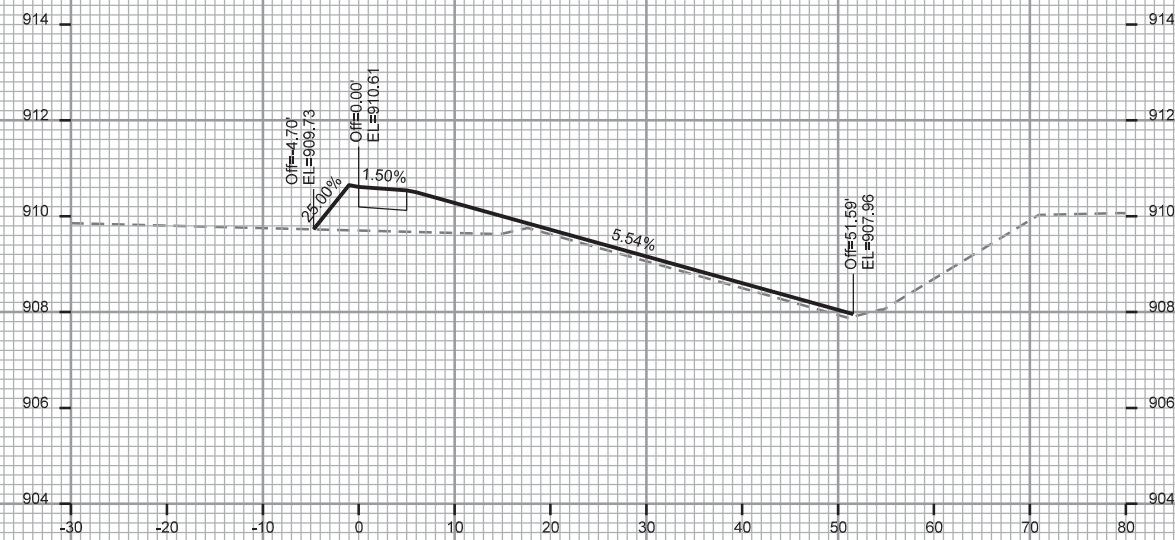



CROSS SECTIONS  
HOEPKER RD SIDEWALK CITY OF MADISON

PLOT SCALE: \_\_\_\_\_

PLOT NAME: \_\_\_\_\_

REV. DATE: \_\_\_\_\_

ORIGINATOR: CITY OF MADISON - STREETS DIVISION

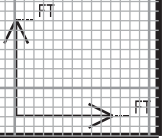
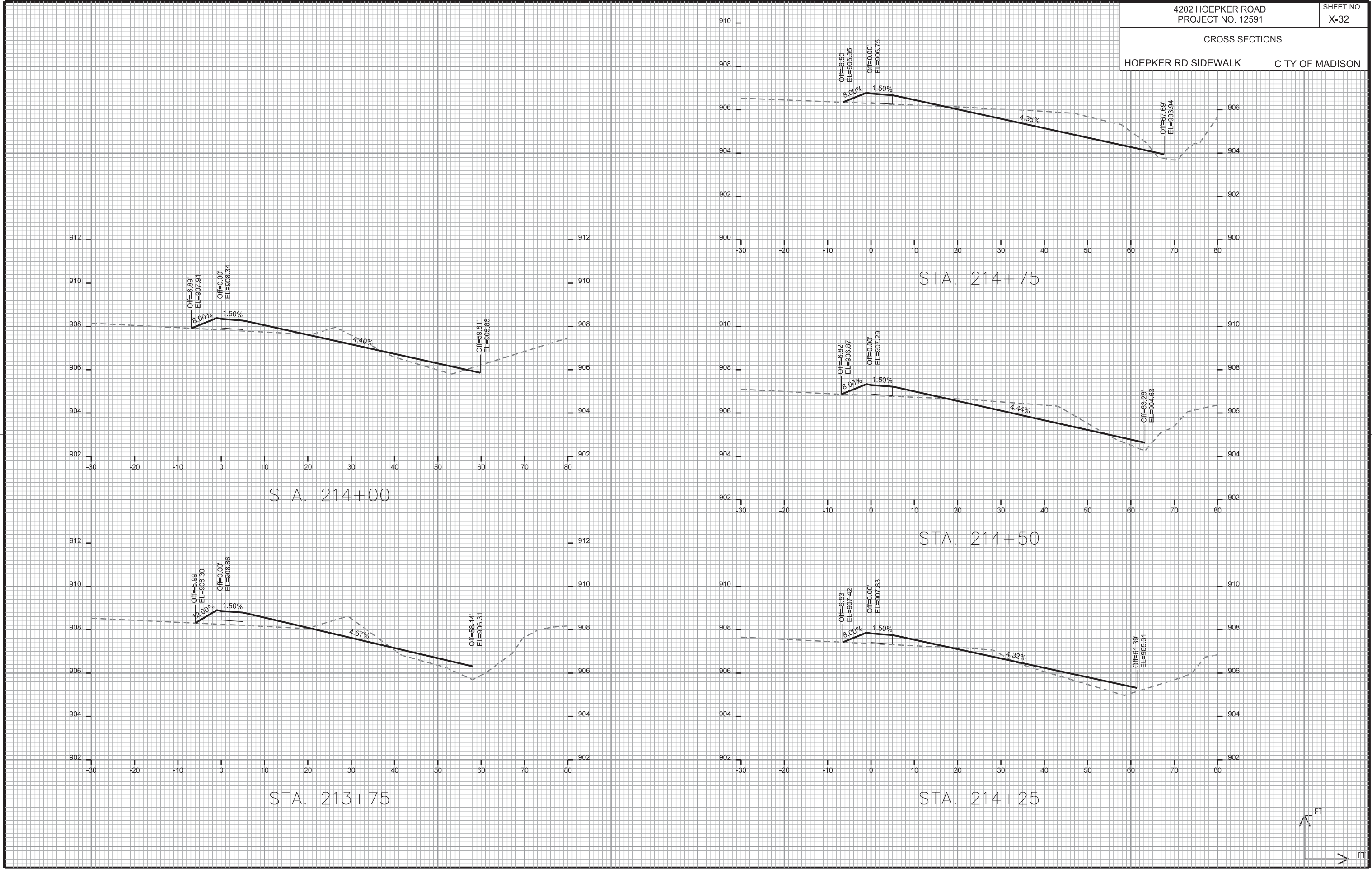

CROSS SECTIONS

HOEPKER RD SIDEWALK

CITY OF MADISON

PLOT SCALE: \_\_\_\_\_

PLOT NAME: \_\_\_\_\_

REV. DATE: \_\_\_\_\_

ORIGINATOR: CITY OF MADISON - STREETS DIVISION

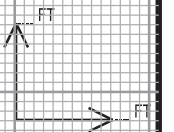
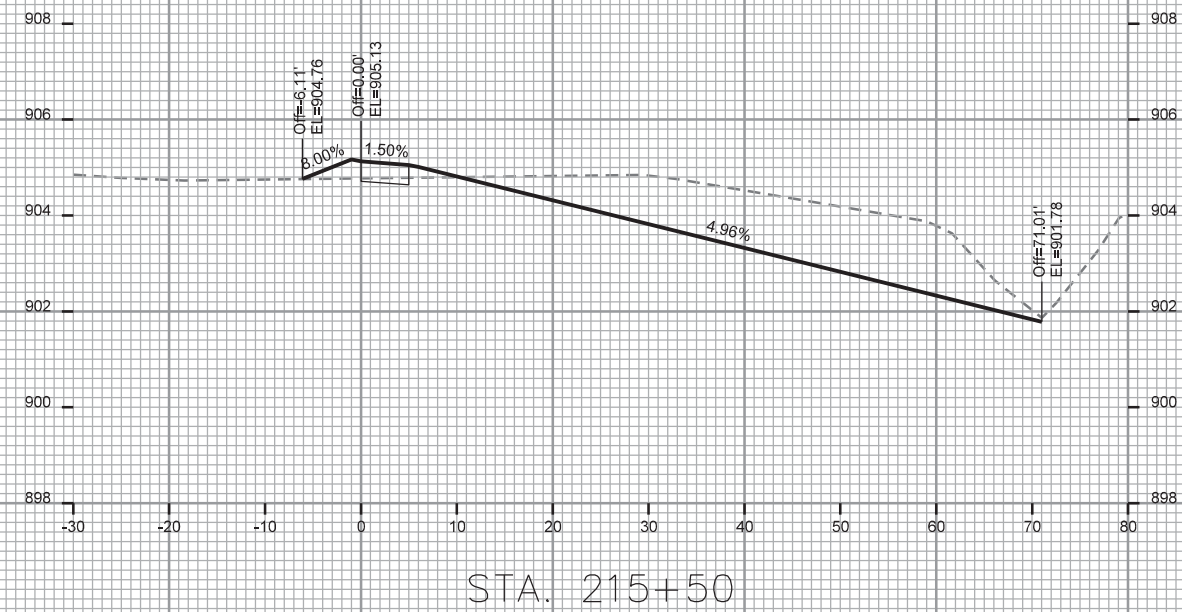
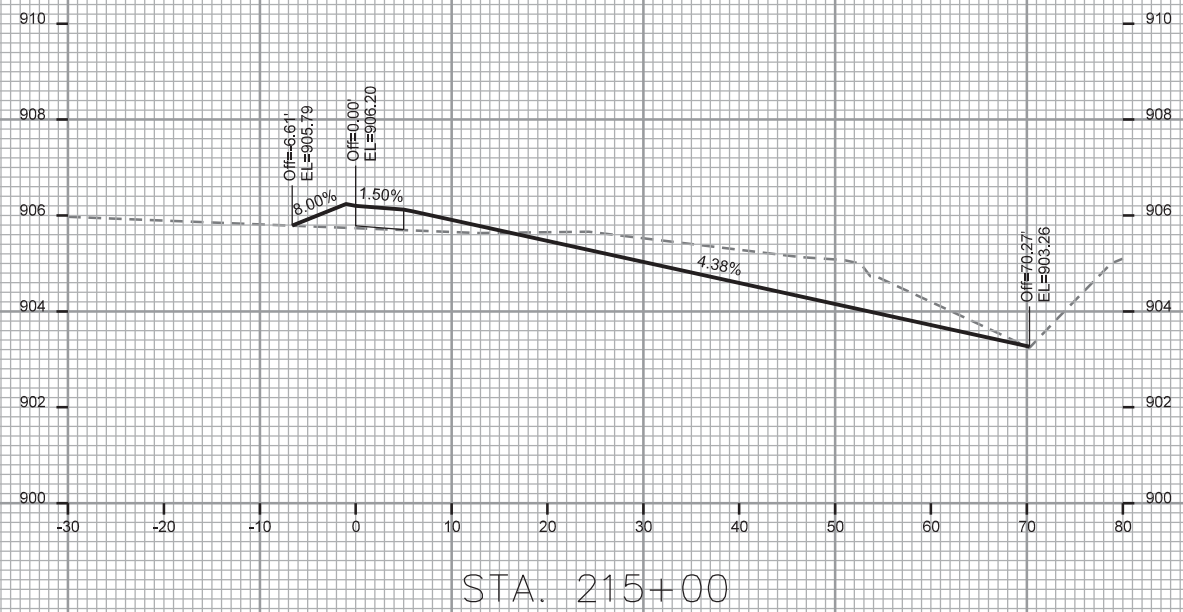
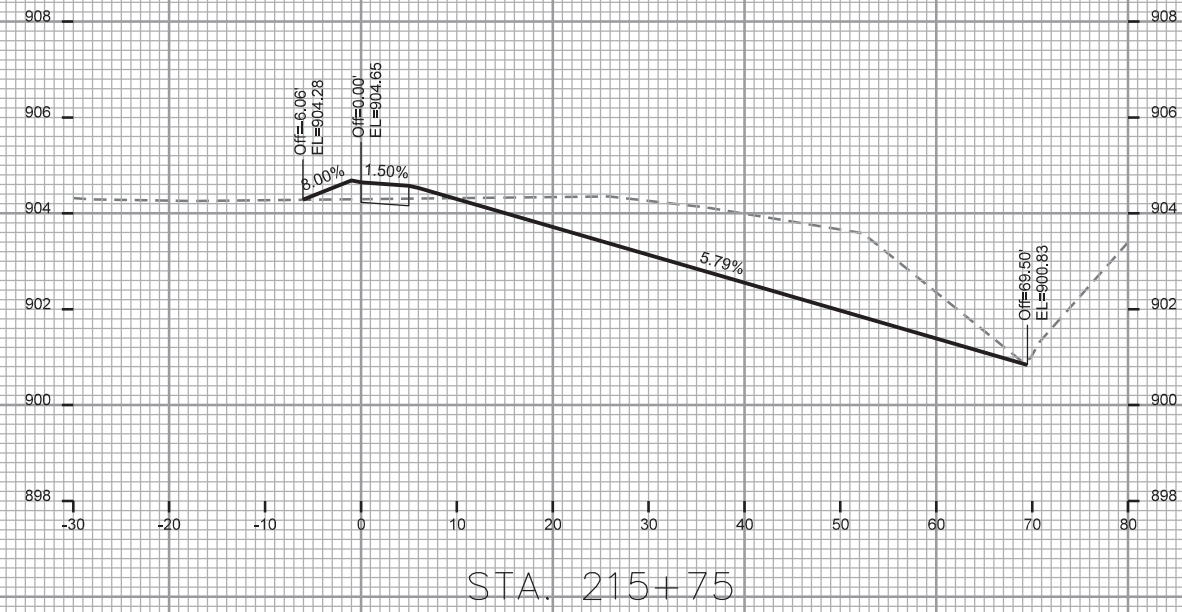
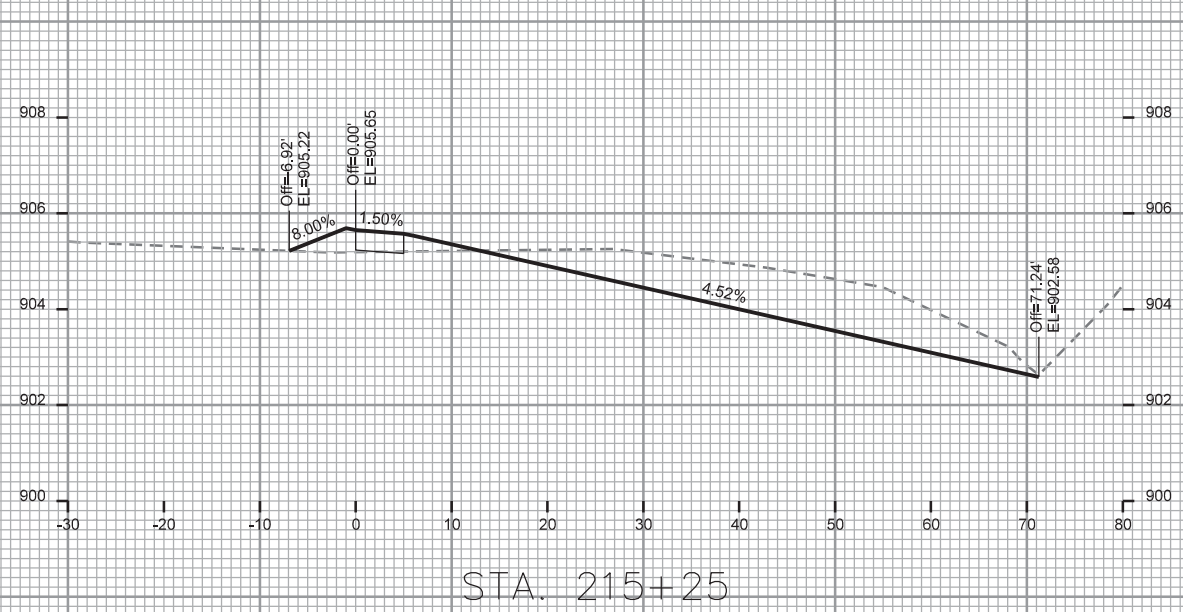

CROSS SECTIONS

HOEPKER RD SIDEWALK

CITY OF MADISON

PLOT SCALE: \_\_\_\_\_

PLOT NAME: \_\_\_\_\_

REV. DATE: \_\_\_\_\_

ORIGINATOR: CITY OF MADISON - STREETS DIVISION

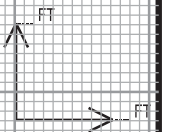
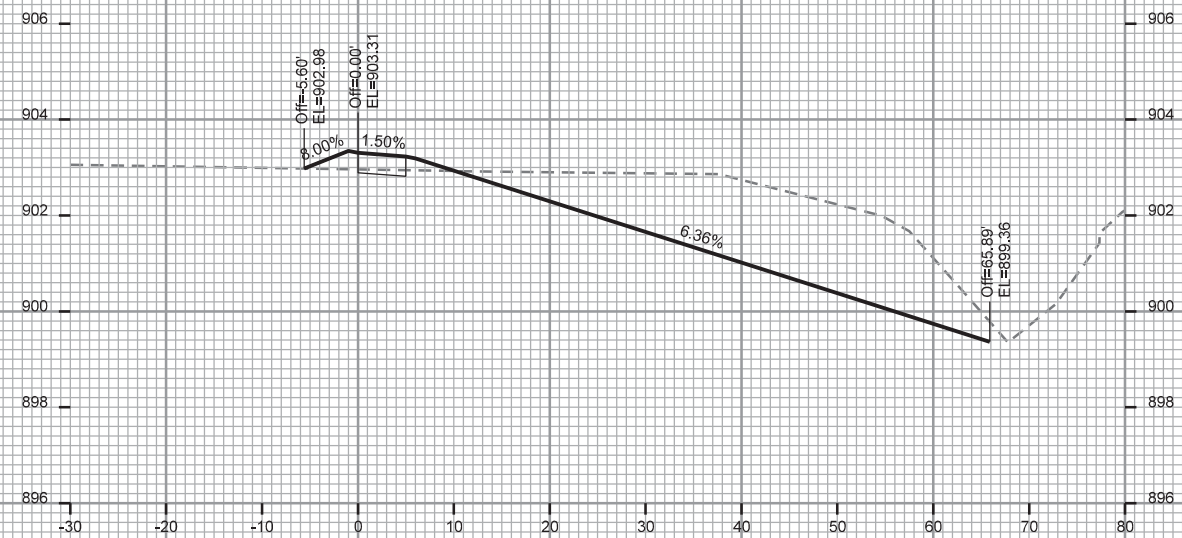
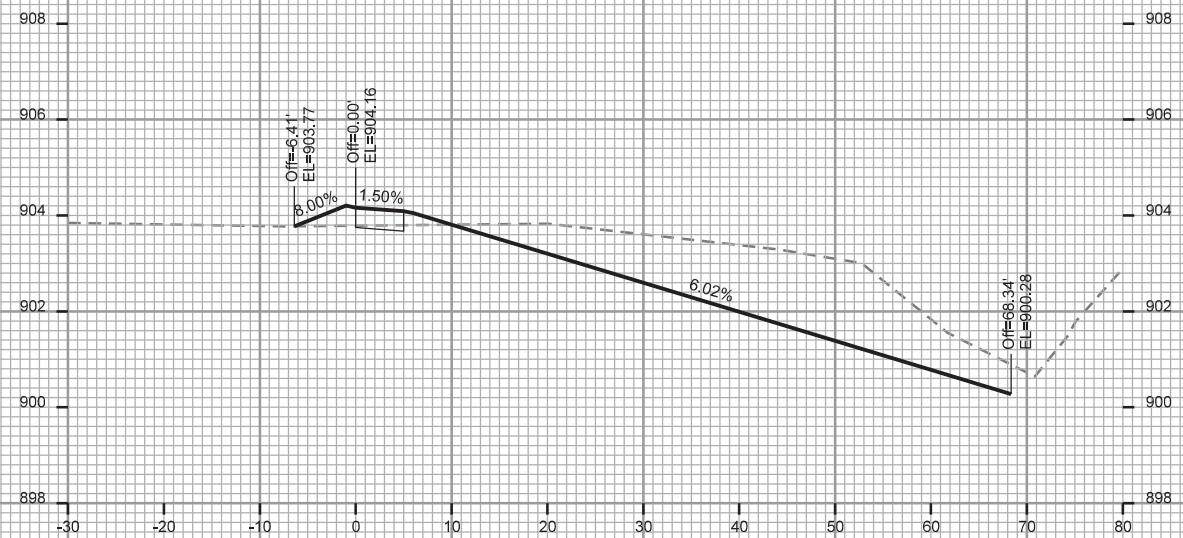
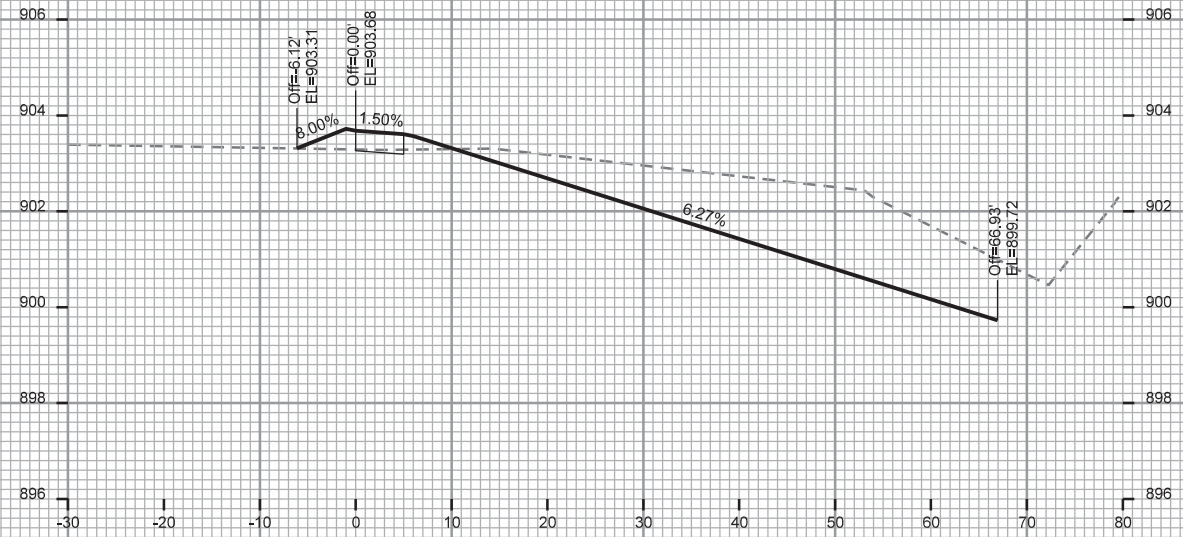



### LEGEND

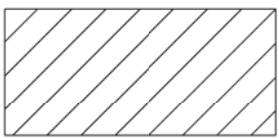

NEW STREET  
(CITY SNOW REMOVAL)

PLOT SCALE: \_\_\_\_\_

PLOT NAME: \_\_\_\_\_

REV. DATE: \_\_\_\_\_

ORIGINATOR: CITY OF MADISON, STREETS DIVISION