

**TRANSPORTATION STANDARDS  
AND DETAILS FOR THE  
ENGINEERING DIVISION**



**DENVER**  
**PUBLIC WORKS**

**CITY AND COUNTY OF DENVER  
PUBLIC WORKS DEPARTMENT**

**Approved By:**

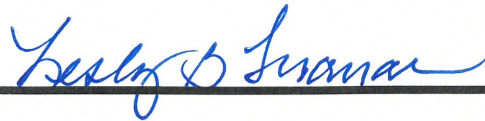
A handwritten signature in blue ink, reading 'Lesley B. Thomas', is written over a solid black horizontal line.

**Lesley B. Thomas, P.E.  
City Engineer**

**APRIL 2017**

Std. Dwg. No.	Description
1.0	Index of Standard Drawings
1.1	Legend
2.0	Local Street Cross-Section and Standard Utility Placement Detail
3.0	Collector – 2 or 3 Lane Cross-Section
4.0	Arterial – 4 Lane with Median and No Parking Cross-Section
4.1	Arterial – 4 Lane with Median and Parking Cross-Section
4.2	Arterial – 6 Lane Cross-Section
5.0	Curb & Gutter and Detached Sidewalk
5.1	Curb & Gutter and Attached Sidewalk
5.2	Typical Curb & Gutter Sections
5.3	Special Use Curb & Gutter Sections
5.4	Concrete Gutter Overlay
5.5	Curb Bulb Extension
5.6	Monolithic Median Curb Nose
6.0	Standard Residential Curb Cut
6.1	Standard Commercial and Multi-Family Curb Cut
6.2	Curb Cut Cross-Sections
6.3	Corner Clearances & Minimum Distances Between Curb Cuts
7.0a,b	General Notes for Curb Ramps
7.1	Curb Ramp Type 1
7.2a	Curb Ramp Type 2
7.2b	Curb Ramp Type 2 Modified (For Combination Curb, Gutter and Sidewalk)
7.3	Curb Ramp Type 3
7.4	Curb Ramp Type 4
7.5	Downtown Signalized Corner Blended Transition
7.6a,b	Curb Ramp Truncated Dome Placement Options
7.7	Curb Ramp Typical Section
7.8	Typical Sidewalk Transitions to Curb Ramp Landing
7.9	Signal Equipment Clear Zone
8.0	Intersection Valley Gutter
8.1	Sidewalk Chase Drain and Tread Plate
9.0	Typical Concrete Bus Pullout
9.1	Typical Concrete Bus Pad in Asphalt Roadway
10.0	Typical Alley Layout
10.1	Alley Cut
10.2	Alley Cut (Historical District)
10.3	Typical Alley Cross-Section
10.4	Alley Curb Head
10.5	"L" Type Alley Configurations
11.0a,b,c	General Notes for Concrete Pavement and Pavement Joints
11.1	Concrete Non-Roadway Joints H and Z
11.2	Concrete Roadway Joints and Transitions A-DA
11.3	Concrete Roadway Joints and Transitions DC-L
11.4	Concrete Roadway Joints and Transitions SA-X
11.5	Concrete Roadway Joint Sealants
11.6	Concrete Roadway Jointing at New Manholes and All Inlets
11.7	Concrete Roadway Jointing at Existing Manholes
11.8	Concrete Roadway Typical Joint Layout
11.9	Concrete Roadway Panel Replacement
11.10	Concrete Street Exploratory Holes (Potholes) Typical Repair
12.0	Asphalt Patch
12.1	Trench Patch Through Existing Gravel or Landscape Materials
12.2	Trench Vertical Patch (Asphalt) in Moratorium Street
12.3	Trench ("T") Patch (Concrete)
12.4	Trench Backfill Material Requirements
12.5	Typical Asphalt Pavement Detail
12.6	Typical Asphalt Pavement Detail Lift Thickness Criteria
12.7	Typical Asphalt Mix Details By Traffic Use or Lift Position
13.0	Tree Planter (Raised Curb)
13.1	Tree Planter (Grates)
13.2	Sidewalk Clear Zones
13.3	Amenity Zone Permeable Pavers
14.0	Standard Cul-de-Sac
15.0	Right-of-Way Survey Control-Range Points



City and County of Denver  
Transportation Standards & Details

Date:  
04/17

Index of Standard Drawings

Std. Dwg.  
1.0

- — — — — or  $\text{C}$  Centerline
- or  $\text{F}$  Flowline or Grade Break
- Right-of-Way Line (R.O.W)
- $\text{A}$  or  $\text{DA}$  or  $\text{B}$  — Concrete Roadway – Expansion Joint per Std. Dwg. 11.2
- $\text{H}$  — Non-Roadway Concrete Expansion Joint per Std. Dwg. 11.1
- $\text{Z}$  — Non-Roadway Concrete Tooled or Sawed Joint per Std. Dwg. 11.1
- $\text{C}$  — Concrete Roadway – Transverse Contraction Joint per Std. Dwg. 11.2
- $\text{CA}$  — Concrete Roadway to Asphalt Pavement Transition per Std. Dwg. 11.2
- +++++  $\text{DC}$  +++++ Concrete Roadway Doweled Transverse Contraction Joint per Std. Dwg. 11.3
- — — — —  $\text{E}$  — Concrete Roadway Longitudinal Contraction Joint per Std. Dwg. 11.3
- $\text{L}$  — Longitudinal Construction Joint also at Curb & Gutter per Std. Dwg. 11.3
- $\text{SA}$  — Sawed Appearance Joint per Std. Dwg. 11.4
- $\text{TE}$  — Concrete Roadway to Existing Curb & Gutter Transition per Std. Dwg. 11.4
- × × ×  $\text{X}$  × × × Concrete Roadway Mid-Panel Transverse Construction Joint per Std. Dwg. 11.4
- $\triangleleft$   $\text{S}$     $\triangleleft$   $\text{SC}$     $\triangleleft$   $\text{SE}$  Concrete Joint Sealants per Std. Dwg. 11.5

- PAR Design Elements
- FLR Accessible Flare Slope = 9.5% (10.0% max)
  - RMP Accessible Ramp Slope = 7.8% (8.3% max)
  - CXS Accessible Cross Slope = 1.5% (2.0% max)
  - RNG Accessible Running Slope = 5.0% max

- ABC Aggregate Base Course
- CLSM Controlled Low Strength Material (Std Dwg. 12.4)
- C&G Curb & Gutter
- FL Flowline
- HMA Hot Mix Asphalt
- PAR 5' Wide Pedestrian Accessible Route (Compliant with FLR, RMP, CXS & RNG)
- PCR Point of Curb Return
- PW City and County of Denver Public Works Dept.

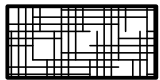

Asphalt

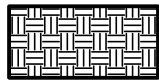

Ground/Subgrade

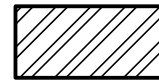

Dry Utility Zone

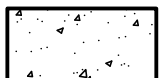

Concrete (Fiber Reinforced per Note G-4 on Std. Dwg. 11.0a)

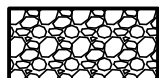

Stabilization Material



Utility Service Crossing Zone

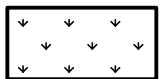

Grass/Landscaping Area

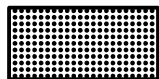

Truncated Dome Panel



Irrigation or Non-Potable Water Use Zone



City and County of Denver  
Transportation Standards & Details

Legend

Date:  
04/17

Std. Dwg.  
1.1

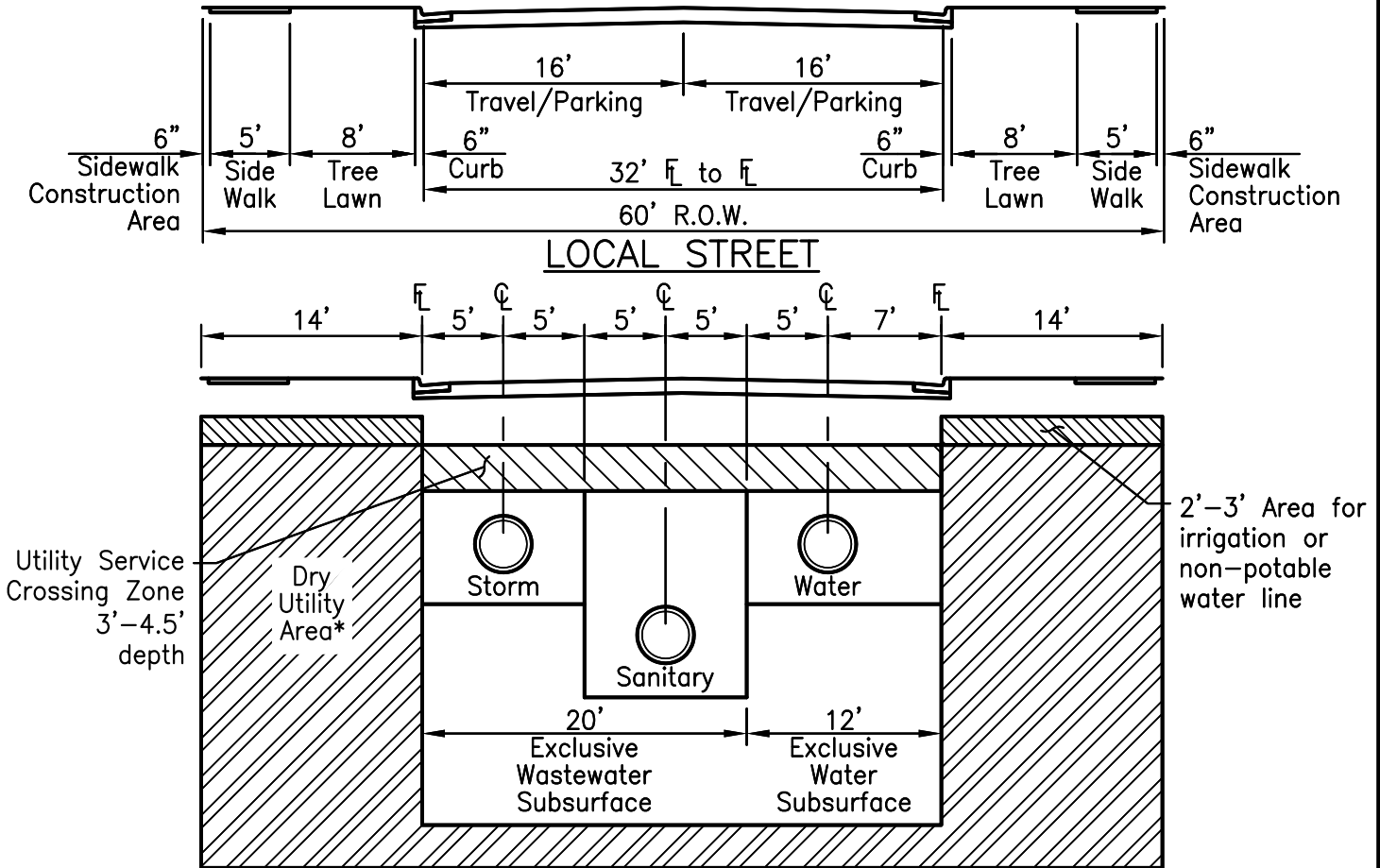

**UTILITIES (TYPICAL)**  
Subsurface Wet Utilities

\*Outside of tree lawn preferred, if unattainable, please contact office of City forester at (720)913-0651.

**Notes:**

1. Parking generally allowed on both sides of the street.
2. R.O.W. may widen to accommodate intersection turn lanes and enhanced pedestrian, bicycle, and transit facilities. Cross-section depicts typical mid-block conditions.
3. At intersections, bulb-outs may be required to enhance pedestrian safety.
4. Cross-section applies for wet utilities less than 15' deep, and maximum pipe inside diameters of: Storm 36"; Sanitary 12"; Water 16".
5. The 32' Cross-section applies to streets adjacent to one or two story single or multi-family buildings, and streets where multi-family housing totals 15 units or less per building. Local streets that are adjacent to denser uses or carry higher traffic volumes than a typical residential street will need to be at least 36' wide and the R.O.W. shall be increased to at least 64' to meet Transportation requirements. Additional width may be required by Denver Fire Department.
6. If all of the following conditions exist, the flowline to flowline width may be decreased to 30':
  - a) Access to the adjacent land use is from the alley only
  - b) Need to accommodate only two wet utilities
  - c) No horizontal curvature
  - d) R.O.W. remains at 60'
  - e) Adjacent land use is single-family or low-density multi-family residential
  - f) The decrease in width will adequately serve transportation system needs, as determined by Public Works.
7. If the adjacent land use is zoned industrial, the flowline to flowline width shall be increased to 36'. No on-street parking will be allowed.
8. For local streets adjacent to community facilities such as schools, recreation centers, and libraries, flowline to flowline width shall be increased to 40'. The R.O.W. shall be increased to 68'. Intersection bulb-outs will be required to enhance pedestrian safety.



City and County of Denver  
Transportation Standards & Details

Local Street Cross-Section and  
Standard Utility Placement Detail

Date:  
04/17

Std. Dwg.  
2.0

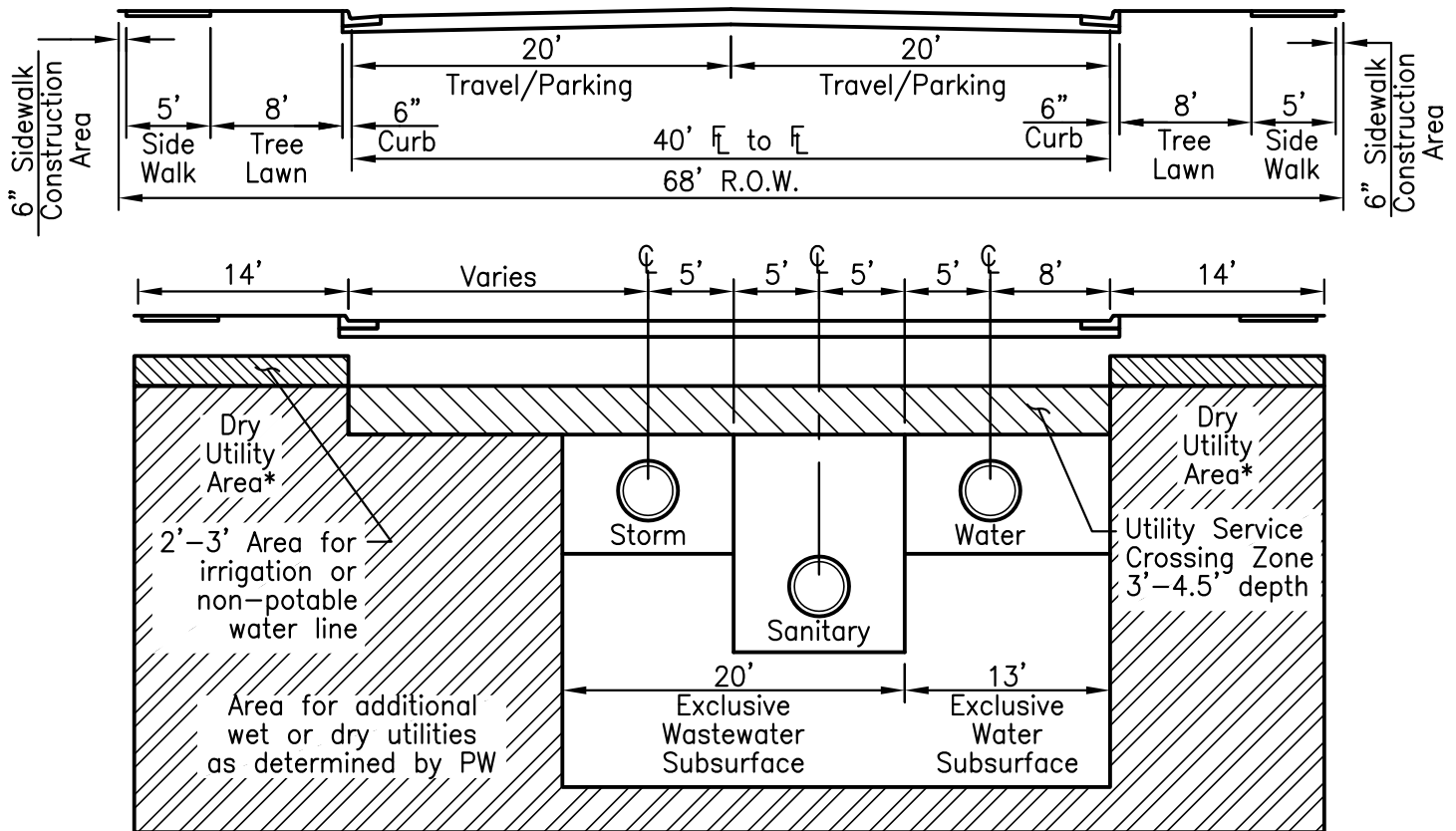

\*Outside of tree lawn preferred, if unattainable, please contact office of City forester at (720)913-0651.

**UTILITIES (TYPICAL)**  
Subsurface Wet Utilities

**Notes:**

1. Parking restrictions may be necessary on one or both sides of the street.
2. R.O.W. may widen to accommodate intersection turn lanes and enhanced pedestrian bicycle and transit facilities. Cross-section depicts typical mid-block conditions.
3. At intersections bulb-outs may be required to enhance pedestrian safety.
4. Cross-section applies for wet utilities less than 15' deep and maximum pipe inside diameters of: Storm 36"; Sanitary 12"; Water 16".
5. For residential land uses, if the following conditions exist the flowline to flowline width may be decreased to 36' (64' R.O.W.), as determined by PW and approved by Denver Fire Department.
  - a. Land use adjacent to street is residential with alley access only and no mid-block street access.
  - b. Streets adjacent to one or two story multi-family buildings.
  - c. Streets where multi-family housing totals 15 units or less per building.
6. For main street or mix-use land uses, if the following conditions exist the flowline to flowline width may be decreased to 36' (64' R.O.W.), as determined by PW and approved by Denver Fire Department:
  - a. Commercial collectors where loading is accommodated on-site or from an alley.
  - b. 2 lane main street collectors where loading is accommodated on-site or from an alley. The amenity zone shall be widened to 15.5'; the R.O.W. remains 68'.
  - c. The decrease in width will adequately serve transportation system needs, as determined by PW.
7. If any of the adjacent land use is zoned industrial, the flowline to flowline width shall be increased to 44' (72' R.O.W.).
8. As determined by PW the 3 lane collector may be required due to frequent access driveways. The 3 lane collector shall accommodate two 11' travel lanes, a 10' painted center left-turn lane, and one 8' parking lane.

	City and County of Denver Transportation Standards & Details	Date: 04/17
	Collector – 2 or 3 Lane Cross-Section	Std. Dwg. 3.0

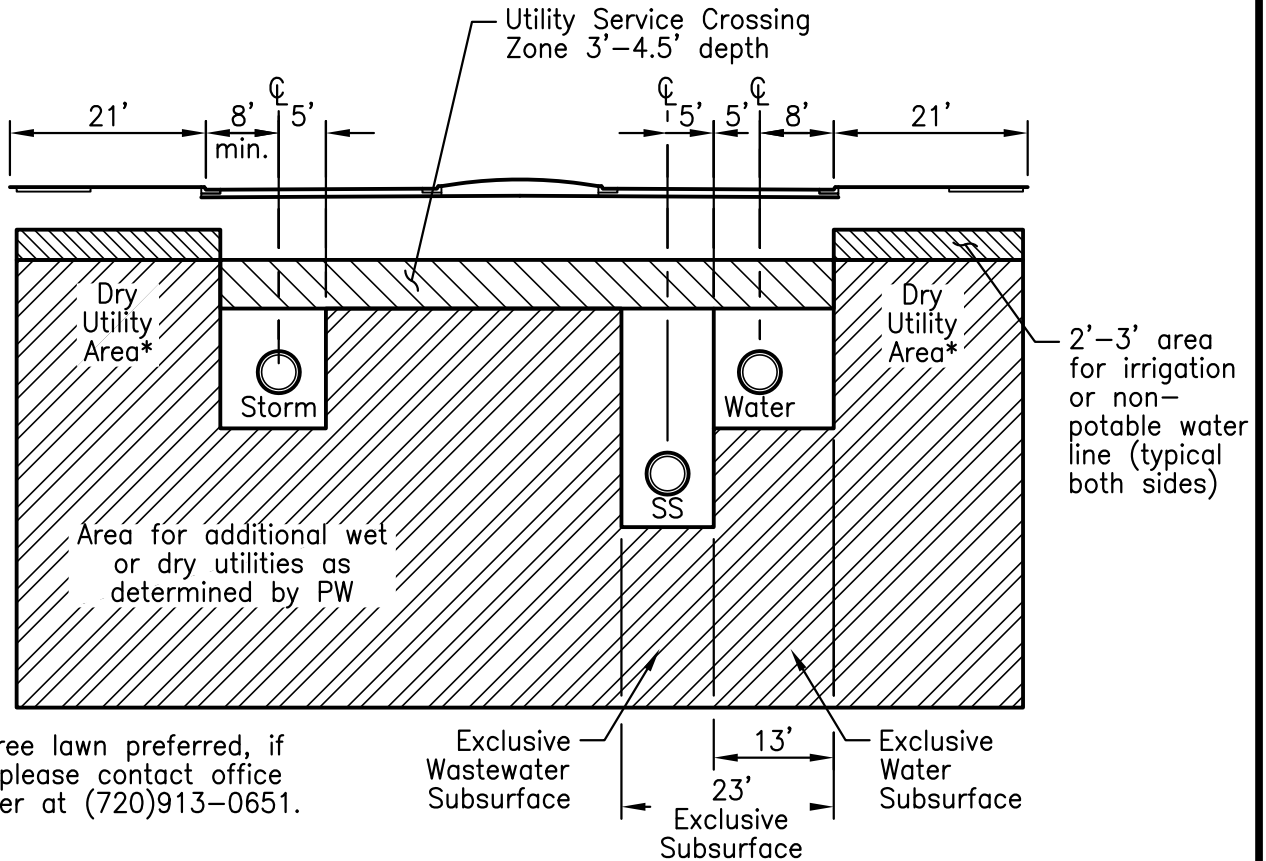
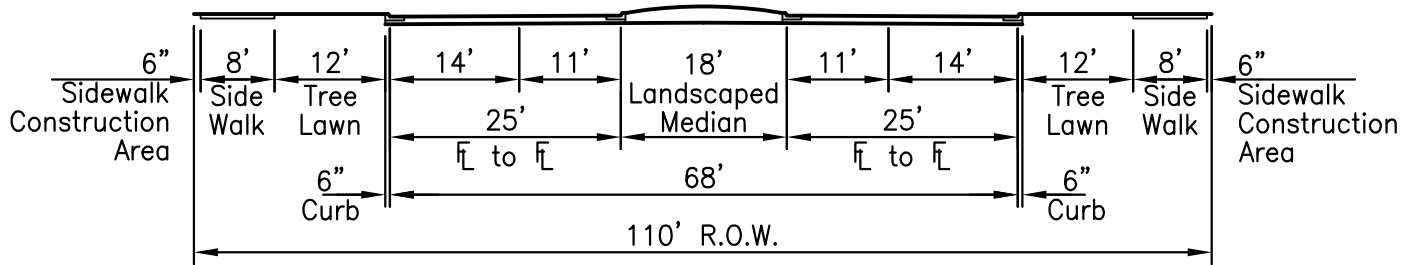

**UTILITIES (TYPICAL)**  
Subsurface Wet Utilities

**Notes:**

1. Additional street width and R.O.W. may be required for certain arterial corridors to accommodate special travel lanes and/or pedestrian, bicycle, or public transit facilities. Cross-section depicts typical mid-block conditions.
2. Cross-section applies for wet utilities less than 15' deep and maximum pipe inside diameters of: Storm 36"; Sanitary 12"; Water 16".
3. Median width may be wider for certain streets as requested by the developer, and approved by PW and Parks & Recreation. Medians will only be maintained by Denver Parks & Recreation with written approval and a maintenance agreement from the Manager of Parks & Recreation prior to median construction.
4. Tree lawn width may be reduced to 8' on infill arterials.
5. Utilities may be placed on either side of the median as long as they meet minimum wet utility spacing requirements.



City and County of Denver  
Transportation Standards & Details

Arterial – 4 Lane with Median  
and No Parking Cross-Section

Date:  
04/17

Std. Dwg.  
4.0

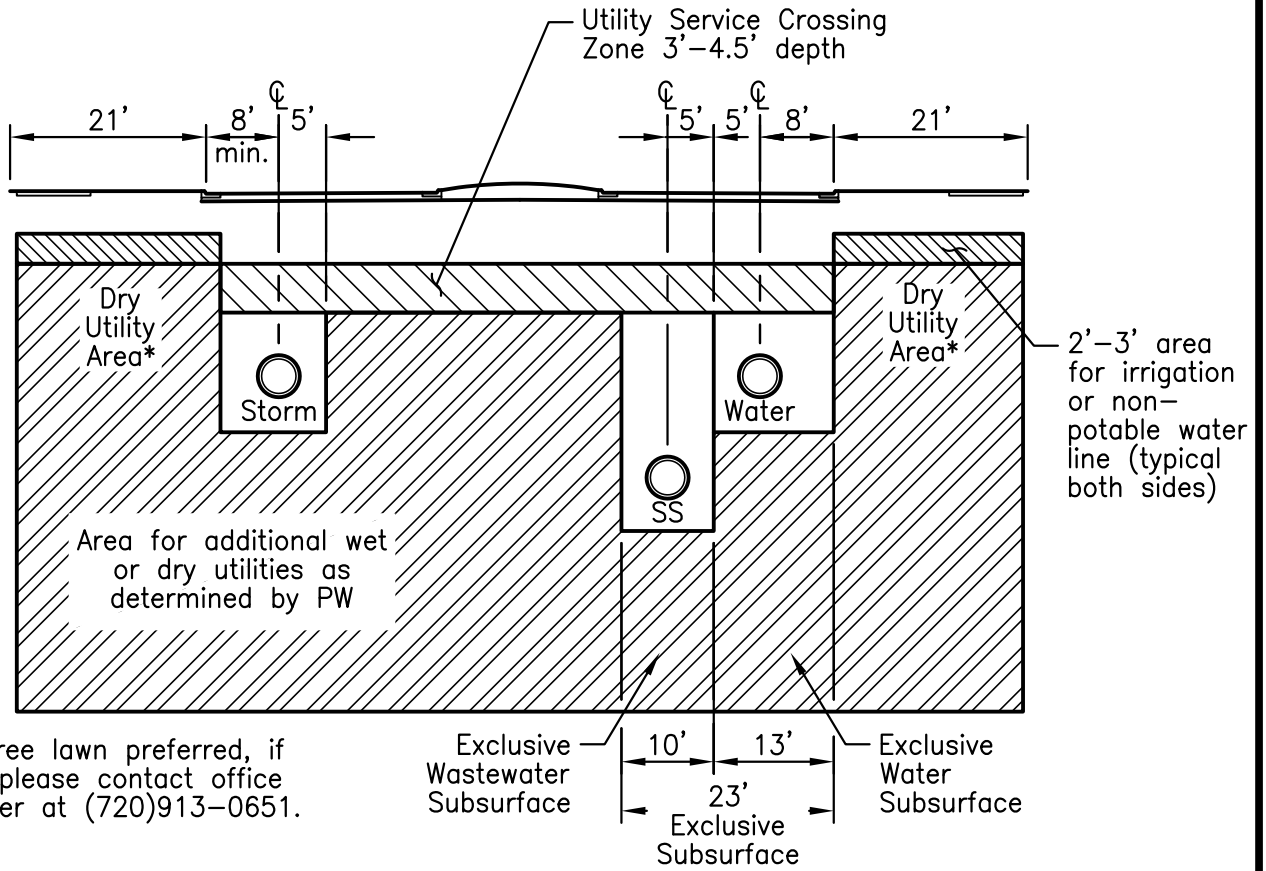
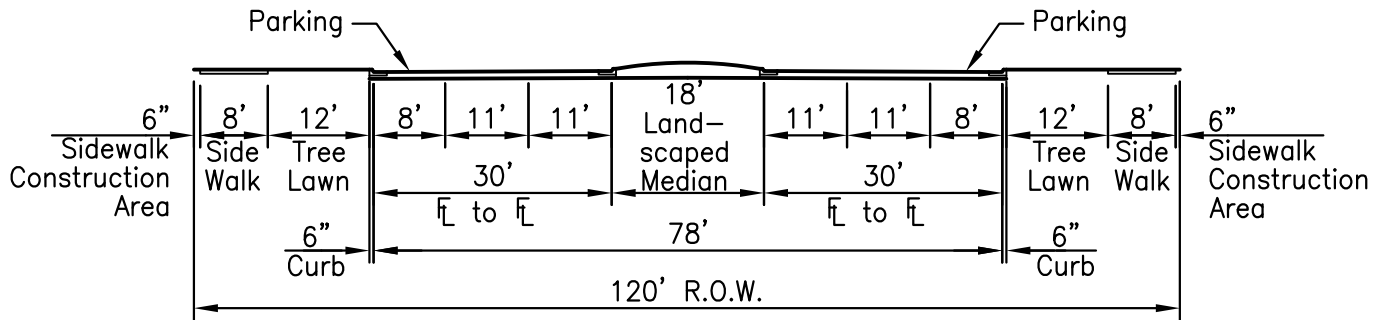

\*Outside of tree lawn preferred, if unattainable, please contact office of City forester at (720)913-0651.

### UTILITIES (TYPICAL)

Subsurface Wet Utilities

**Notes:**

1. Parking is generally allowed except at intersections or major access points where additional travel lanes are needed.
2. Additional street width and R.O.W. may be required for certain arterial corridors to accommodate special travel lanes and/or pedestrian, bicycle, or public transit facilities. Cross-section depicts typical mid-block conditions.
3. At intersections bulb-outs may be required to enhance pedestrian safety.
4. Cross-section applies for wet utilities less than 15' deep and maximum pipe inside diameters of: Storm 36"; Sanitary 12"; Water 16".
5. Median width may be wider for certain streets as requested by the developer and approved by PW and Parks & Recreation. Medians will only be maintained by Denver Parks & Recreation with written approval and a maintenance agreement from the Manager of Parks & Recreation prior to median construction.
6. Utilities may be placed on either side of the median as long as they meet minimum wet utility spacing requirements.



City and County of Denver  
Transportation Standards & Details

Arterial – 4 Lane with Median  
and Parking Cross-Section

Date:  
04/17

Std. Dwg.  
4.1

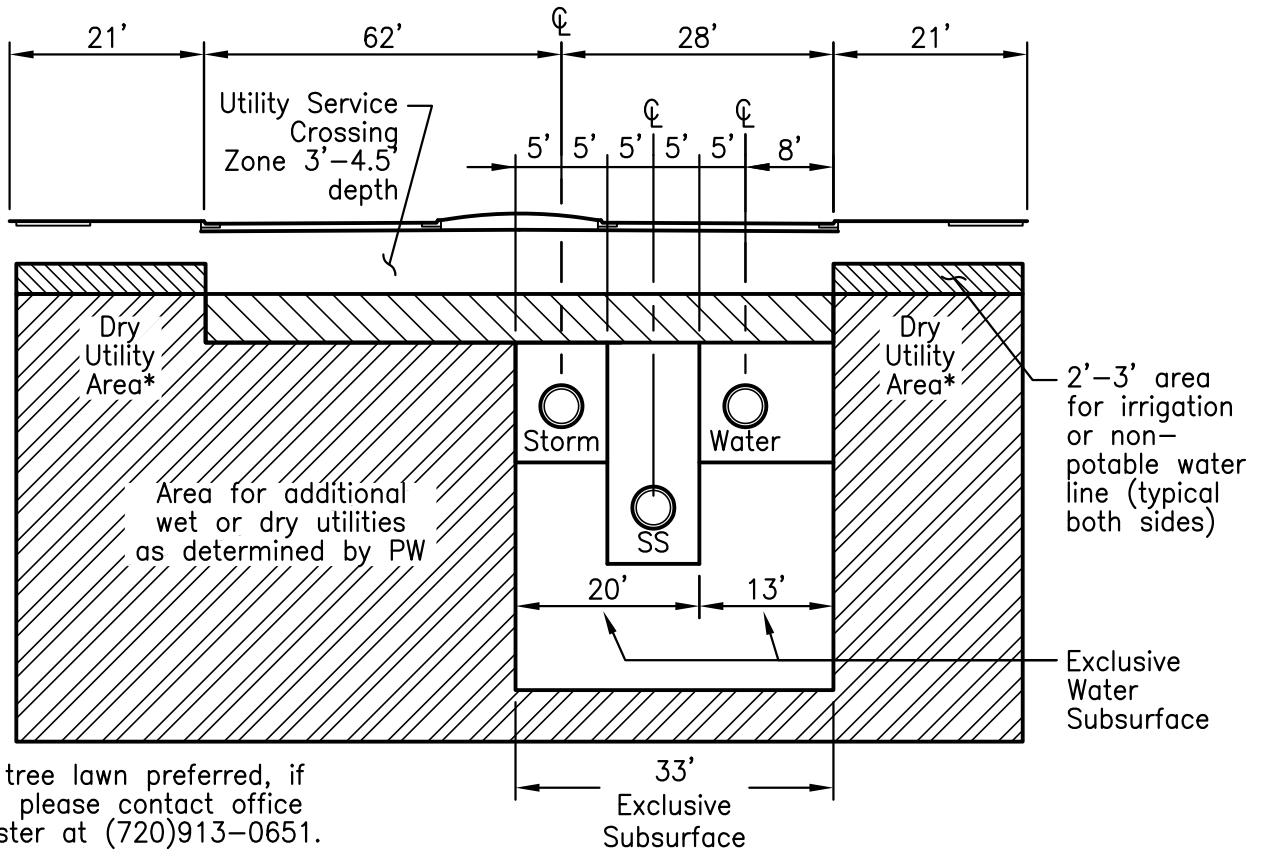
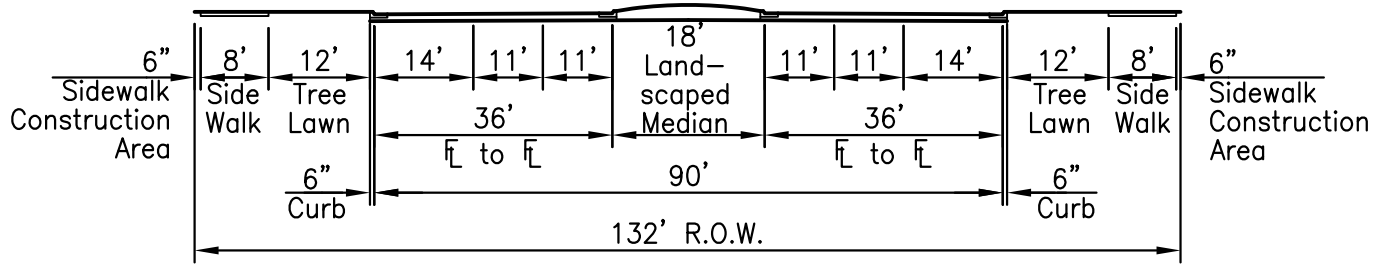

\*Outside of tree lawn preferred, if unattainable, please contact office of City forester at (720)913-0651.

### UTILITIES (TYPICAL) Subsurface Wet Utilities

**Notes:**

1. Parking is generally not allowed on arterial roadways.
2. Additional street width and R.O.W. may be required for certain arterial corridors to accommodate special travel lanes, parking, and/or pedestrian, bicycle, or public transit facilities. Cross-section depicts typical mid-block conditions.
3. Cross-section applies for wet utilities less than 15' deep and maximum pipe inside diameters of: Storm 36"; Sanitary 12"; Water 16".
4. Median width may be wider for certain streets as requested by the developer and approved by PW and Parks & Recreation. Medians will only be maintained by Denver Parks & Recreation with written approval and a maintenance agreement from the Manager of Parks & Recreation prior to median construction.
5. Utilities may be placed on either side of the median as long as they meet minimum wet utility spacing requirements.



City and County of Denver  
Transportation Standards & Details

Arterial – 6 Lane Cross-Section

Date:  
04/17

Std. Dwg.  
4.2



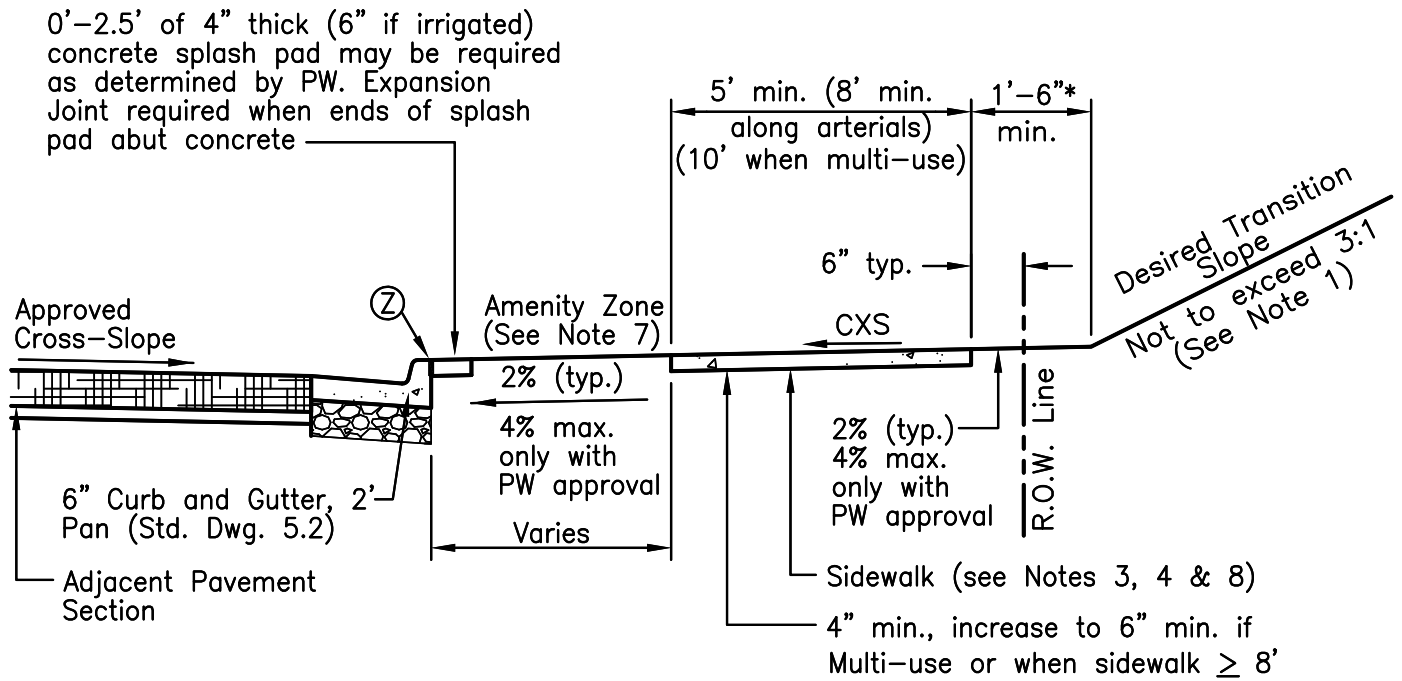

## TYPICAL SECTION – CURB & GUTTER WITH DETACHED SIDEWALK

\* If construction on private property is required to meet these transition dimensions, a separate agreement with owner of affected property will be required.

### Notes:

1. Side slope may exceed 3:1 only with the approval of PW.
2. Proposed variations from minimum dimensions shall be approved by PW in writing.
3. Tree grates cannot be used as part of the sidewalk.
4. Sidewalk Materials: The sidewalk material shall be concrete. For limited sidewalk replacement work, such as replacing several sidewalk panels for a utility trench, the replacement sidewalk material may match the existing sidewalk material when approved by PW. Sandstone may only be used for limited replacement sidewalk material under the following conditions:
  - a) No horizontal or vertical gaps or joints larger than 0.25" are allowed. Joints should be filled with sand.
  - b) Sandstone must be at least 4" thick by 5' long (minimum) by 2' wide (minimum). Driving surfaces should be at least 6" thick. May use two layers to achieve this thickness.
  - c) Sandstone must be set on a minimum 2" thick sand base under fitted with a rot resistant geotextile fabric. PW may require a drainage system for some installations. Drainage systems, when required, must be able to support HS-20 loading.
  - d) Sandstone should only be used on streets with a running slope less than or equal to 5%. Sandstone sidewalk on steeper slopes may not meet accessible route slip resistance criteria.
5. Refer to Std. Dwg. 12.0 for patching and saw cut details.
6. Placement of empty 3" schedule 40 PVC conduit is required behind the back of curb along the entire project/property frontage when warranted by the traffic operations Conduit Engineer (720)865-4000 for future street lights, signals, etc.
7. All plantings within the amenity zone shall be per PW Encroachment Rules & Regulations. No loose material is allowed. Decorative concrete or low growing plant material may be allowed only with the specific approval of PW. Trees shall be a minimum of 20' from property corners at intersections, 25' from street lights, 10' from the edge of driveways, 20' from curb ramps and 30' from stop signs. PW will only allow "knitted" or "gorilla hair" shredded bark mulch under trees out to drip line, per latest forestry guidelines.
8. If bricks were approved by PW for use as sidewalk, they shall be wet-set or mortared to a 4 inch thick concrete base layer (or sub-walk).



City and County of Denver  
Transportation Standards & Details

Curb & Gutter and Detached  
Sidewalk

Date:  
04/17

Std. Dwg.  
5.0

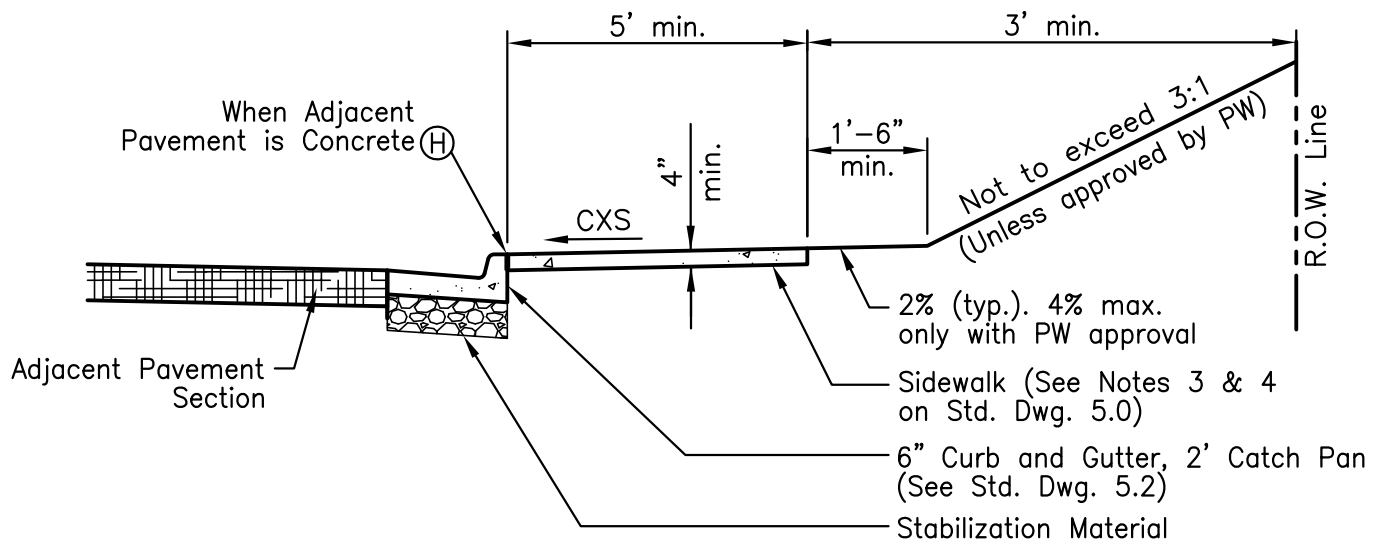

**TYPICAL SECTION—6" CURB & GUTTER WITH ATTACHED SIDEWALK**

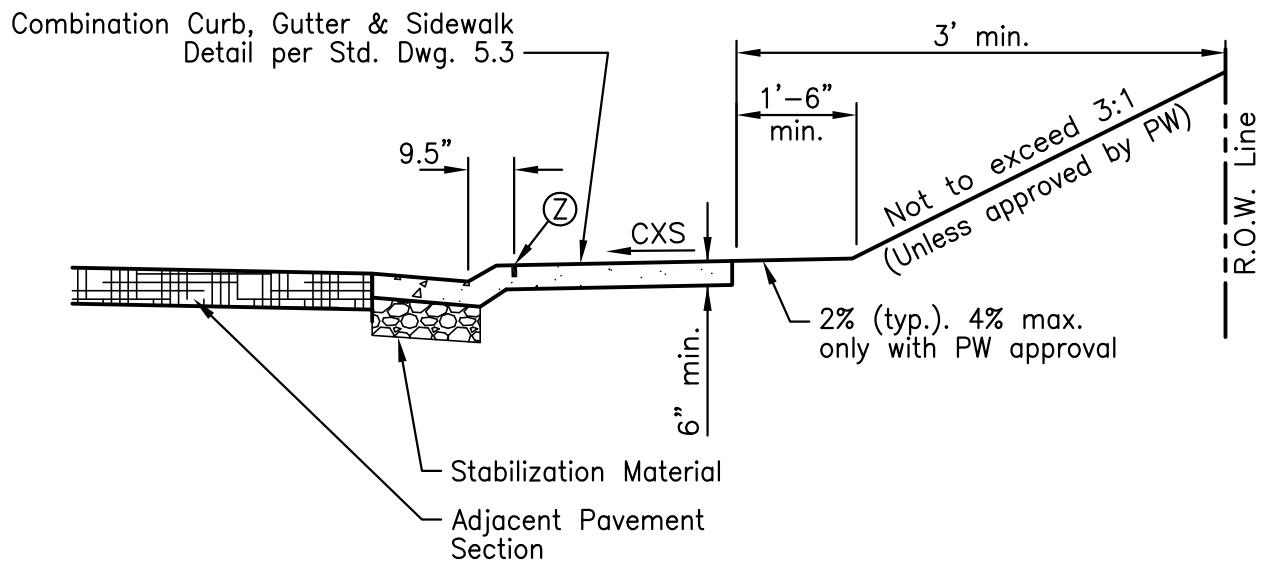

**TYPICAL SECTION—COMBINATION CURB, GUTTER, & SIDEWALK**

This section is only for use to repair or replace existing sections of combination curb, gutter and sidewalk.



City and County of Denver  
Transportation Standards & Details

Curb & Gutter and Attached  
Sidewalk

Date:  
04/17

Std. Dwg.  
5.1

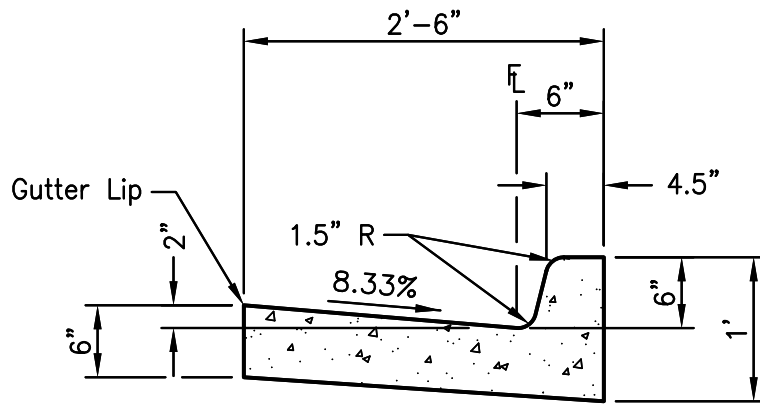

6" CURB AND GUTTER-2' CATCH PAN

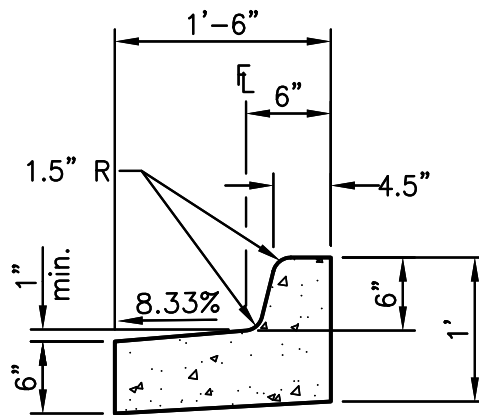

6" CURB AND GUTTER-1' SPILL PAN

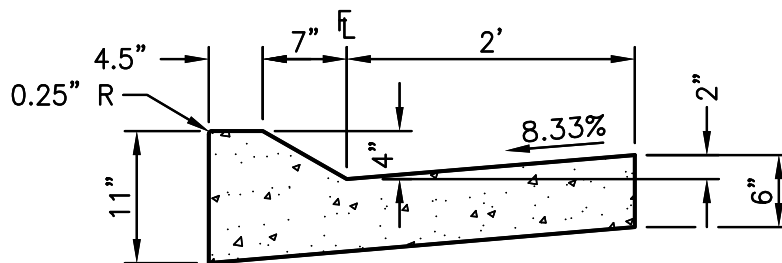

4" MOUNTABLE CURB

For existing conditions only

Note:

1. Curb and gutter section lengths shall be 10' long typical and adjusted in length so that adjacent concrete pavement joint lines will continue through the curb and gutter. Maximum length of any curb and gutter section is 12'.
2. Refer to Std. Dwg. 11.9 for additional information on how concrete panel replacement affects curb and gutter.
3. Gutters must transition at all Curb Ramps per ramp details.
4.  $\frac{3}{4}$ " preformed expansion joint material to be placed between sections at or near the PCR at every concrete street intersection. Expansion joints shall be placed between C&G sections where an asphalt street abuts a concrete street.
5. 8.33% gutter slope is required in all cases, including concrete streets, except at curb ramps.



City and County of Denver  
Transportation Standards & Details

Typical Curb & Gutter Sections

Date:  
04/17

Std. Dwg.  
5.2

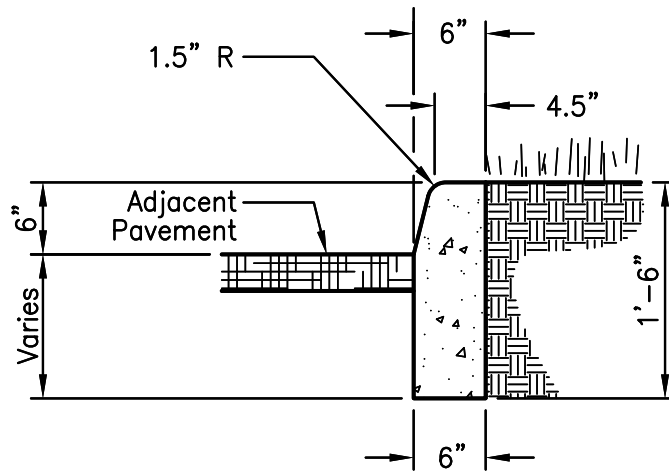

### 6" CURB HEAD

**Notes:**

1. This section is only for use to repair or replace existing sections of 6" curb head.
2. When adjacent to existing asphalt paving, a minimum 2' wide asphalt patch is required per Std. Dwg. 12.0 when installing new curb head.
3. Larger curb head sections may be required by PW.

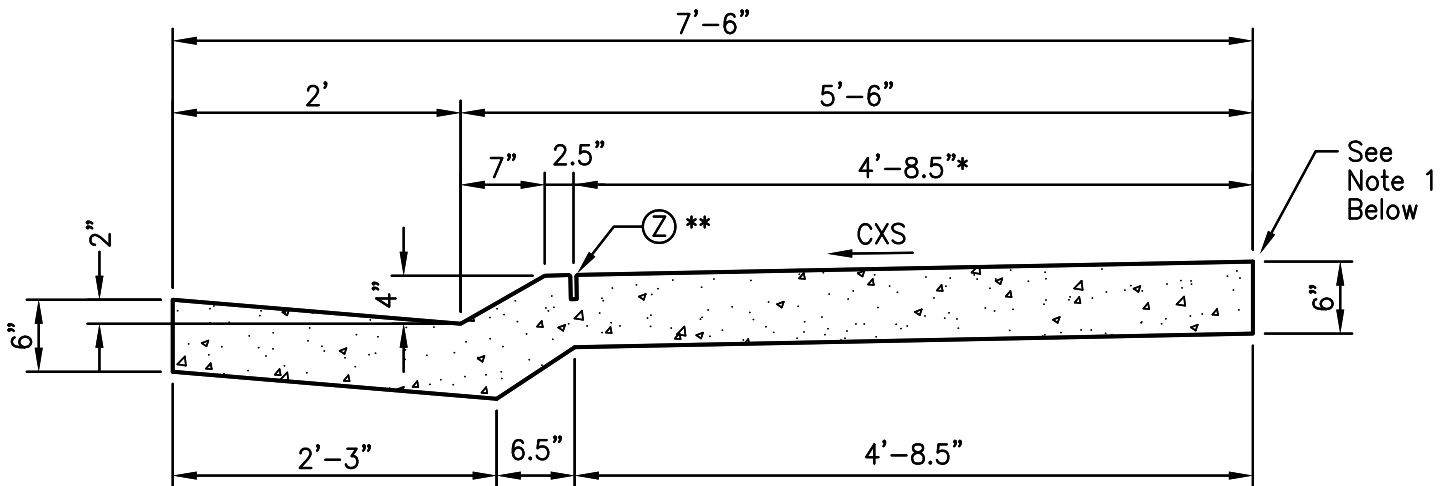

\*Match existing width on repair projects under 50' in length only (3' absolute minimum width).

\*\*This joint is also the sawcut point for sidewalk repairs.

### COMBINATION CURB, GUTTER AND SIDEWALK (5')

This section is only for use to repair or replace existing sections of combination curb, gutter and sidewalk.

**Notes:**

1. Apply  $\text{\textcircled{L}}$  (at C&G) joint wherever PW has approved attaching new 6" thick sidewalk to the outside edge of any existing combination curb, gutter and sidewalk.



City and County of Denver  
Transportation Standards & Details

Special Use Curb & Gutter  
Sections

Date:  
04/17

Std. Dwg.  
5.3

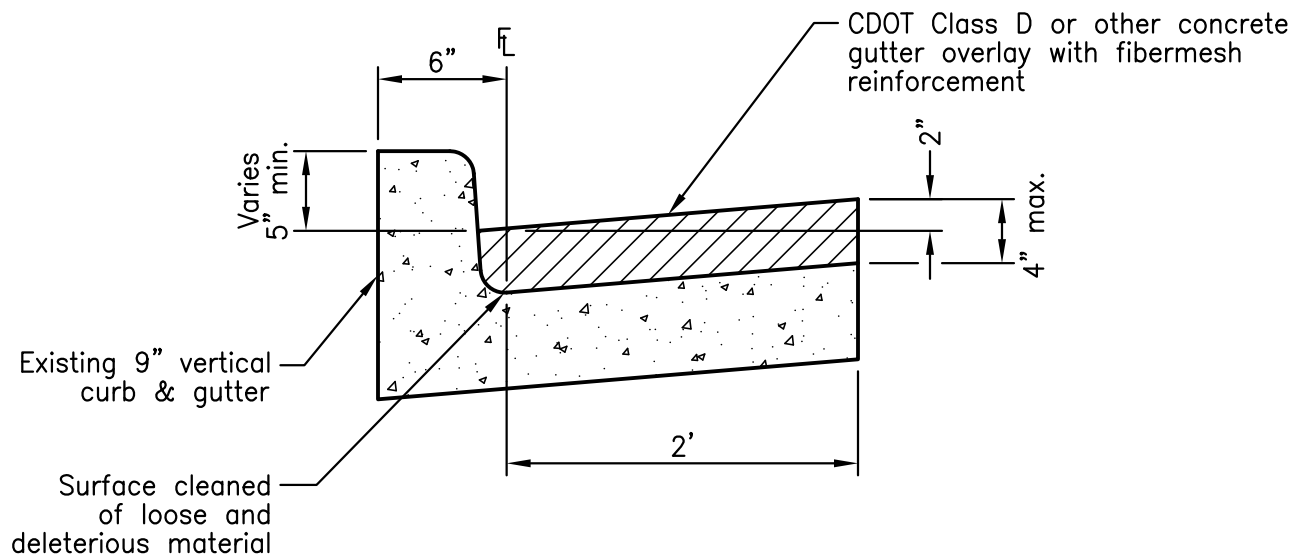

## CONCRETE GUTTER OVERLAY

**Notes:**

1. For limited use with existing 9" curb and gutter only, and only with approval of PW. Not for new construction.
2. Transitions to existing concrete gutters (or to asphalt flowline when in gutter overlay) on either side of a concrete gutter overlay shall be carefully evaluated to identify future project impacts and ensure that drainage is preserved.
3. All transitions shall be approved by PW.



City and County of Denver  
Transportation Standards & Details

Concrete Gutter Overlay

Date:  
04/17

Std. Dwg.  
5.4

Approximate location of crosswalk, sidewalk & curb ramps. Complete design required as part of curb bulb extension, to be approved by PW  
See Note 6.

Street section shall be carefully reviewed for impacts of proposed curb bulb geometry and elevations, including interface with existing street cross section. Installation of curb bulb extensions can affect minor storm gutter drainage and major storm street drainage capacity, and as such must be reviewed and approved by PW in writing on a case-by-case basis.

(H) When adjacent roadway is concrete, otherwise (Z)

Parking Area (Typ.)

Existing adjacent C&G

Point of Curvature (P.C.)

42.5' min P.C. 20' min. Length of bulb

Flowline slope all places (See note 4)

4'-8' Typ.

15' min. Radius See notes 1&2

Coordinate with PW to properly design parking, striping or other transition treatments in this area.

The additional amenity zone created by curb bulb extension shall be properly designed to be compatible with adjacent street and walk grades

ADA compatible attached or detached sidewalk surface or as otherwise approved by PW

Existing Adjacent C&G

(H) When adjacent roadway is concrete, otherwise (Z)

Limits of street cut patching as determined by curb bulb extension design. See Note 6

Notes:

1. Where length of bulb-out is desired to be as short as possible, the bulb-out radius closest to the traffic lane (near edge) may be reduced to 12'. In rare circumstances, this radius can be reduced to 10' upon written approval of PW.
2. The reverse curves at each end of the parking pocket shall be tangent to each other, and each curve shall be tangent with the curb line continuing in each direction.
3. The length of the bulb is measured as 20' from the closest edge of the crosswalk, which is typically defined as the closest point of the curb ramp throat, or the marked crosswalk, when present. Any reduction in this length shall be approved by PW.
4. Bulb-out design shall ensure positive 0.7% preferred, 0.5% min, drainage slope at all points along new bulb-out flowline.
5. If there is an existing or proposed bus stop or driveway at the corner, the length of the bulb should be lengthened to accommodate the full length of the bus stop/driveway. The depth and length of the extension will be approved by PW.
6. Limits of street cut and patching shall be set to ensure that the PAR route within the street (the crosswalk) is not adversely affected by causing any PAR design elements to be exceeded. In some cases, removal of entire street from curb to curb may be required.



City and County of Denver  
Transportation Standards & Details

Curb Bulb Extension

Date:  
04/17

Std. Dwg.  
5.5

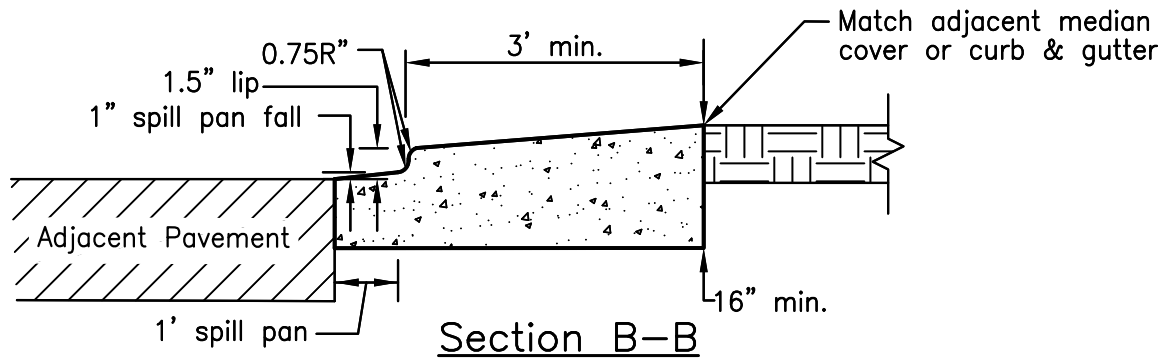
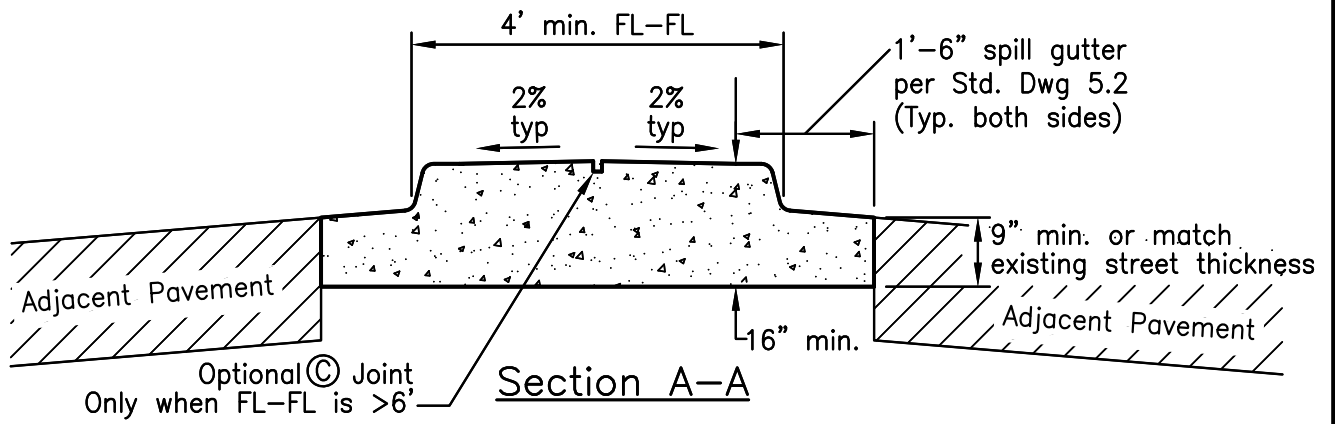
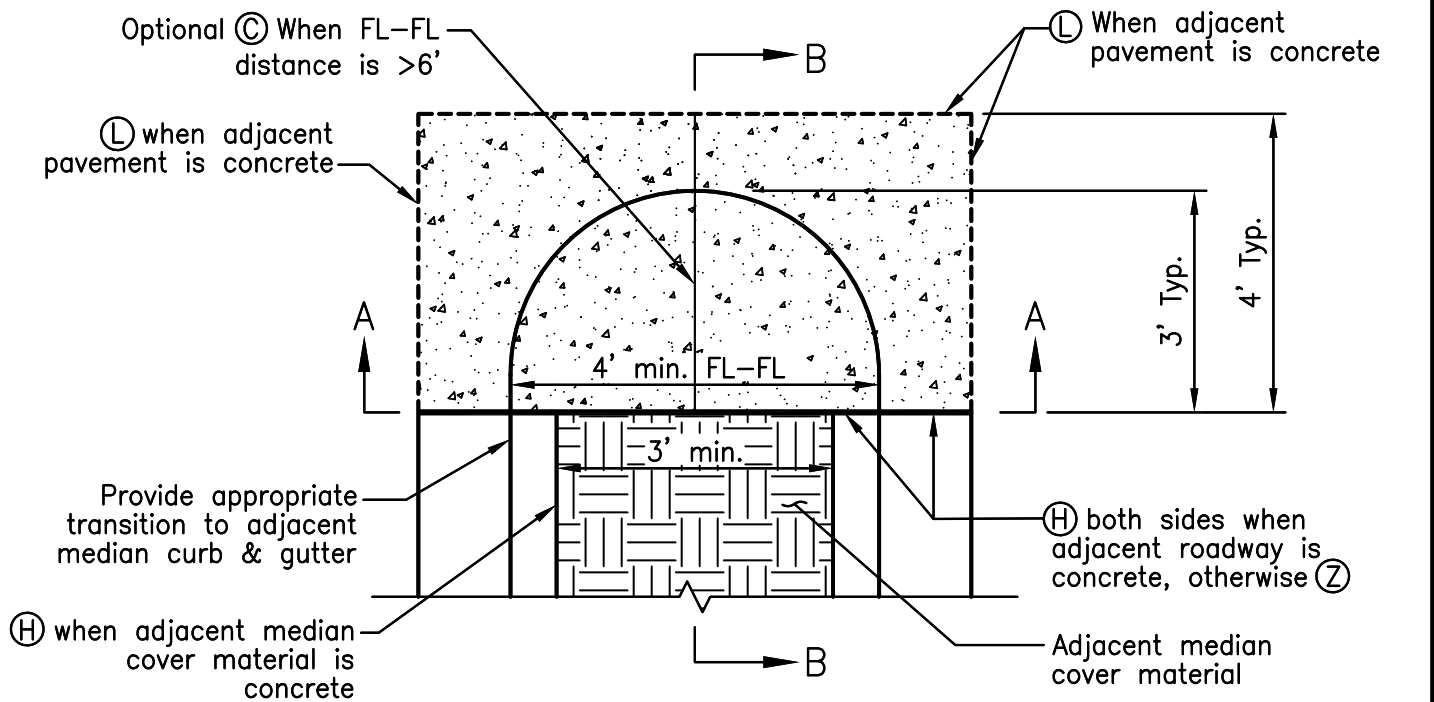

- Notes:
1. Median nose shall be poured monolithically with curb and gutter transition.
  2. Curb height at median nose may be adjusted with approval by PW.



City and County of Denver  
Transportation Standards & Details

Date:  
04/17

Monolithic Median Curb Nose

Std. Dwg.  
5.6

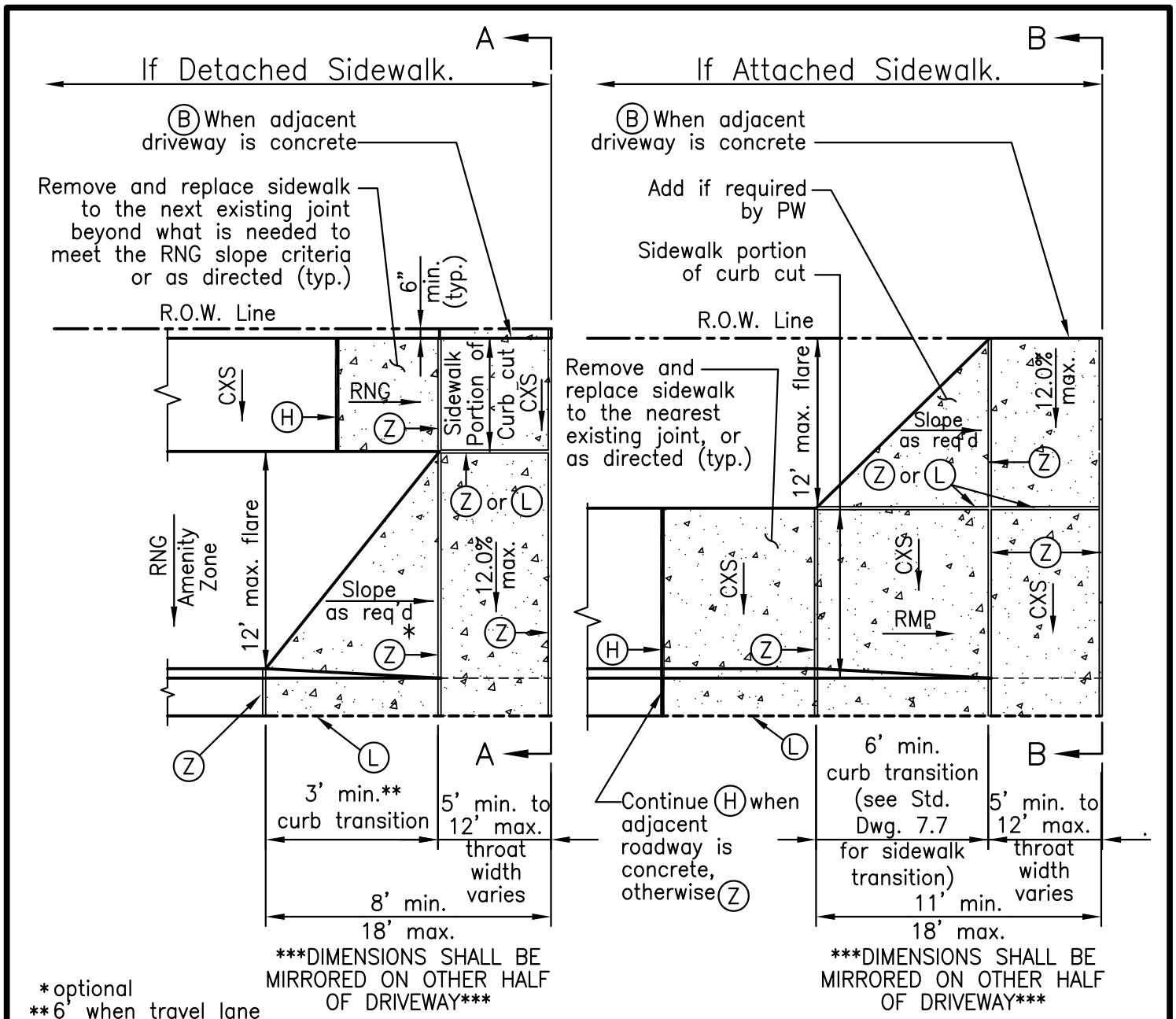

### STANDARD RESIDENTIAL CURB CUT

**Notes:**

1. Apply asphalt patch requirements in Std. Dwg. 12.0 when driveway is installed adjacent to existing asphalt street.
2. Additional tooled joints may be required to provide definition of sidewalk or driving surfaces or to control the location of cracking.
3. On-site parking stalls that back into the driveway aisle shall be located a minimum of 10' from the R.O.W. line, measured to the nearest point of the parking space.
4. Any garage door or gate shall be located a minimum of 20' from the R.O.W. line and/or back of sidewalk, whichever is closer. A garage door or gate located at an exit only may be located at the R.O.W. line only by specific written permission of PW.
5. The sidewalk portions of the curb cut shall match the width and alignment of the approaching sidewalk, with a minimum width of 5' and a cross-slope of CXS toward the flowline.
6. Contact Office of City Forestry at (720)913-0651 prior to performing any work within the drip line of existing R.O.W. trees.



City and County of Denver  
Transportation Standards & Details

Standard Residential Curb Cut

Date:  
04/17

Std. Dwg.  
6.0



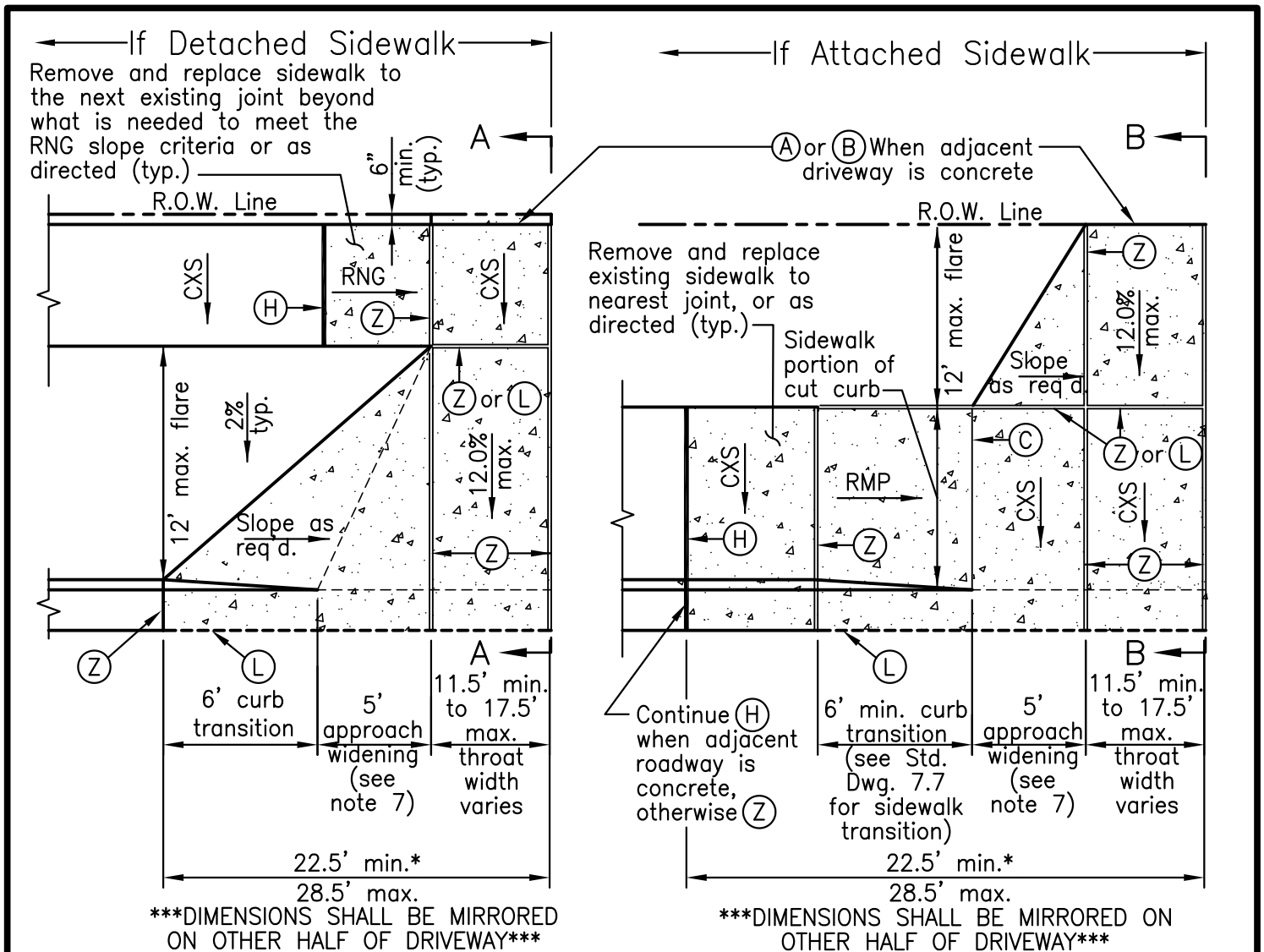

\*Widths beyond min./max. dimensions shown must be approved by PW.

### STANDARD COMMERCIAL & MULTI-FAMILY CURB CUT

**Notes:**

1. Apply asphalt patch requirements in Std. Dwg. 12.0 when driveway is installed adjacent to existing asphalt street.
2. Additional tooled joints may be required to provide definition of sidewalk or driving surfaces or to control the location of cracking.
3. On-site parking stalls that back into the driveway aisle shall be located a minimum of 10' from the R.O.W. line, measured to the nearest point of the parking space.
4. Any garage door or gate shall be located a minimum of 20' from the R.O.W. line and/or back of sidewalk, whichever is closer. A garage door or gate located at an exit only may be located at the R.O.W. line only by specific written permission of PW.
5. The sidewalk portions of the curb cut shall match the width and alignment of the approaching sidewalk, with a minimum width of 5' and a cross-slope of CXS toward the flowline.
6. Contact Office of City Forester at (720)913-0651 prior to performing any work within the drip line of existing R.O.W. trees.
7. Narrower approach widening widths due to site constraints must be approved by PW.



City and County of Denver  
 Transportation Standards & Details

Standard Commercial and  
 Multi-Family Curb Cut

Date:  
 04/17

Std. Dwg.  
 6.1

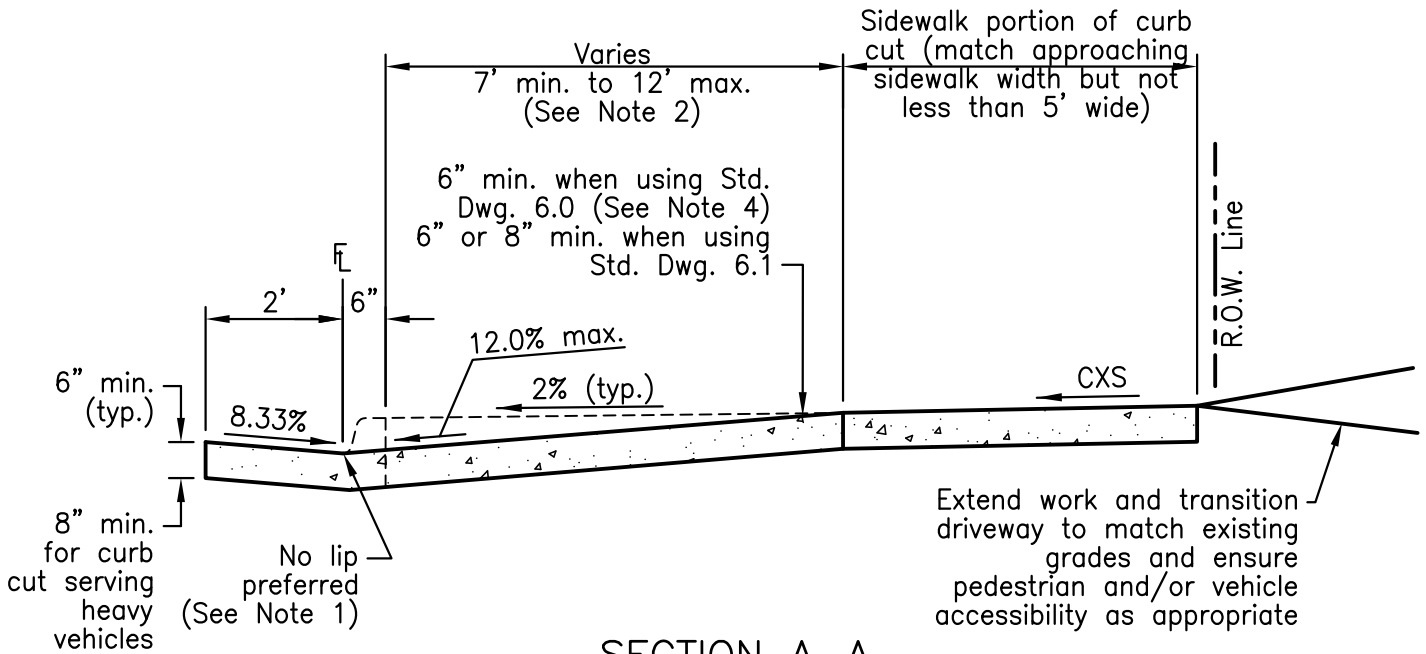

**SECTION A-A**

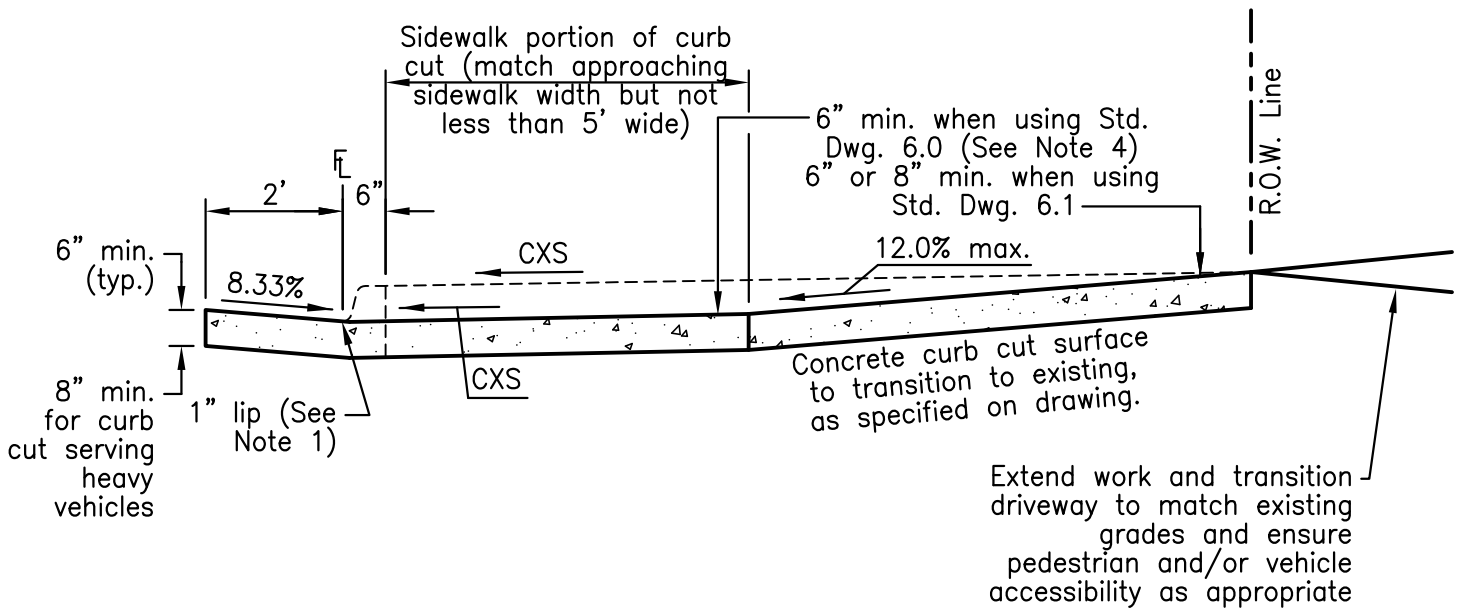

**SECTION B-B**

Notes:

1. When maintaining maximum 8.33% driveway grade is difficult or to prevent ponding, a 1" lip (1.5" maximum allowed) with 0.125" R at flowline may be installed.
2. When this dimension is less than 7', a special detail must be developed to show how the approaching sidewalk will transition to the lower curb cut.
3. Concrete curb cuts require fibermesh reinforcement at minimum 1.5 pounds per cubic yard.
4. Driveways expected to service any heavy, non-passenger truck traffic shall provide 8" thick concrete at all places.
5. Contact Office of City Forester at (720)913-0651 prior to performing any work within the drip line of existing R.O.W. trees.



City and County of Denver  
Transportation Standards & Details

Curb Cut Cross-Sections

Date:  
04/17

Std. Dwg.  
6.2

### Intersecting Roadway

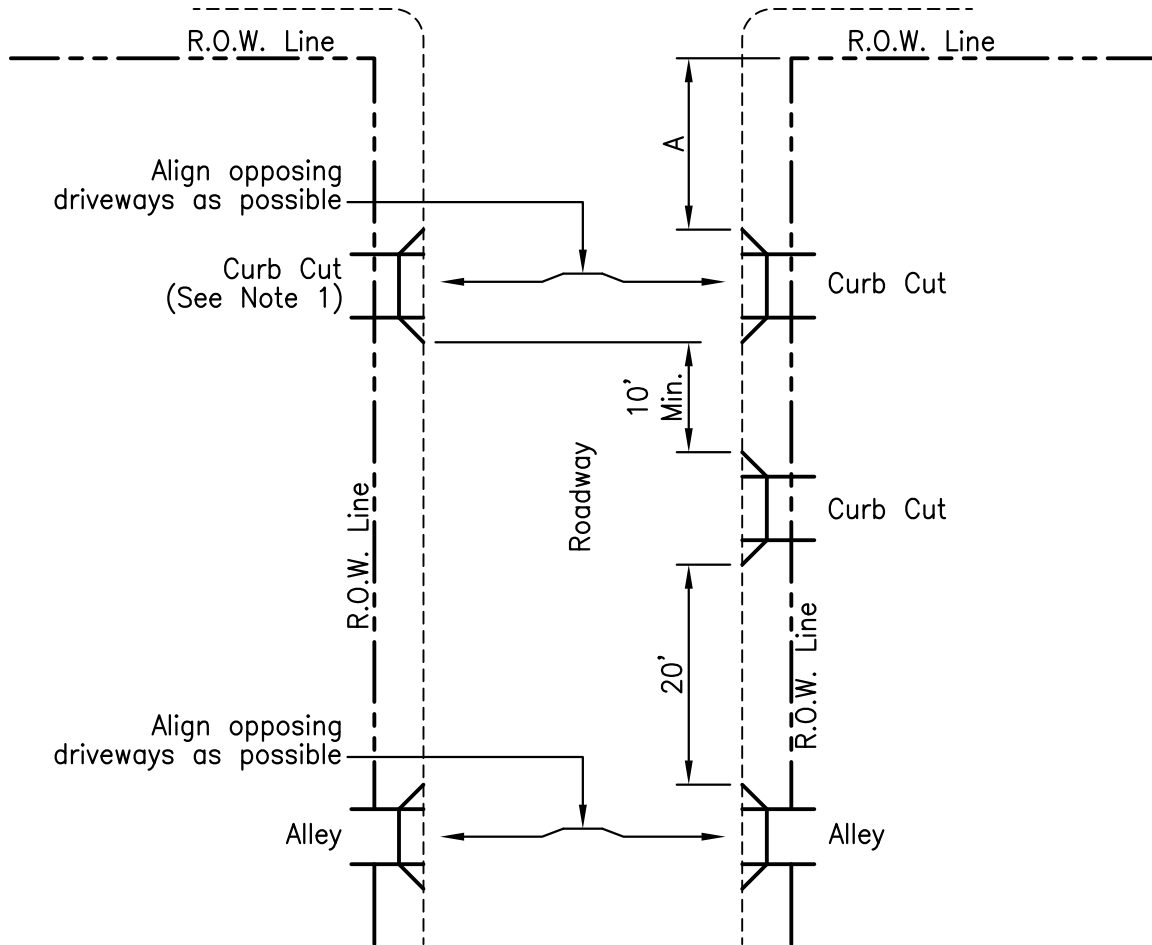

Roadway Classification	Corner Clearance 'A' (min. in feet)
Arterial	100
Collector	75
Local	20/40 (See Note 2)

**Notes:**

1. If placing a new curb cut on the side of a street opposite an existing driveway, the new curb cut shall directly align with an existing driveway or maintain a minimum 10' of separation between flares.
2. On local roads, corner clearance is 40' when the intersecting roadway is an arterial and 20' for all other classes of intersecting roadways.
3. Additional corner spacing may be required at signalized intersections to keep curb cut clear of required turn lanes.
4. All new curb cuts must be specifically approved in writing by PW.
5. Contact Office of City Forester at (720)913-0651 prior to performing any work within the drip line of existing R.O.W. trees.



City and County of Denver  
Transportation Standards & Details

Corner Clearances & Minimum  
Distances Between Curb Cuts

Date:  
04/17

Std. Dwg.  
6.3

## GENERAL NOTES FOR CURB RAMPS

1. The following Curb Ramp types are general representations and many require modifications to fit actual field conditions. Most applications within the City are retrofit situations where one or more constraints such as limited R.O.W., significant grade differences, and drainage concerns must be taken into account in locating the Curb Ramp. Design resources are available within the City to assist with the proper selection and application of ramp types to maintain applicable Standards.
  - Type 1 Ramps are for use in areas where the sidewalk is set back from the street, and pedestrian access from the side of the ramp is not likely to occur because the approach area is covered by landscaping or an obstacle is present.
  - Type 2 Ramps are for use where pedestrian access can occur from both sides of the ramp. Modified Type 2 ramps are for use in retrofit situations wherever there are existing obstructions or inadequate R.O.W.
  - Type 3 Ramps are for use where sidewalk is attached on one side, detached on the other, and pedestrian access can occur from only one side.
  - Type 4 Ramps are for use when there are existing obstructions or there is not sufficient room in the R.O.W. to construct a Type 1, 2, or 3 Ramp, including the landing at the top of the ramp and a PAR around the top of the ramp.
  - Downtown Signalized Corner Blended Transitions are for use in the Downtown area or other areas where the entire radius is depressed to eliminate use of teardrop islands between ramps.

Consult with PW for procedures and standards to follow for ramps located in Denver Landmark Districts, abutting Denver Landmark Districts, or for districts and structures listed in the National Register of Historic Places.

2. Refer to the most current version of the City and County of Denver "Sidewalk and Curb Ramp Construction Rules and Regulations" and "Curb Ramp Installation and Replacement Policy and Procedures" for additional design parameters.
3. Curb Ramps shall be positioned as directionally as possible to align with opposing curb ramps.
4. Grade breaks at the top and bottom of curb ramp runs shall be perpendicular to the direction of the ramp wherever possible and per Std. Dwg. 7.6a-b.
5. Placement of single diagonal or mid-block Curb Ramps must be approved in writing by PW.
6. For each Curb Ramp installation, additional removal and replacement of existing sidewalks may be required to facilitate proper transitions to ramp. When "chasing grade," ramp and sidewalk transition length need not exceed 15' per Std. Dwg. 7.7.
7. Curb Ramps shall match approaching clear sidewalk width, or 5' minimum, whichever is greater. Curb Ramp throat width shall not exceed 8' unless serving a shared use path, for which the throat width shall not exceed 10'.
8. Contact Office of City Forester at (720)913-0651 prior to performing any work within the drip line of existing R.O.W. trees.
9. The design cross-slope of the Curb Ramp surface shall be 1.5%. Where ramps are being constructed on existing streets, the cross-slope of the ramp shall evenly transition to match the longitudinal street flowline grades at the bottom of the ramp.
10. The 'slope' of the gutter in front of a ramp shall be RNG. For a standard 2' gutter pan, this results in a maximum gutter depth of no more than 1.2". To transition from the standard 2" gutter depth to an accessible 1.2" depth in front of the ramp, warp the gutter lip in a 2' to 6' curb & gutter section adjacent to the ramp, as shown on each standard ramp drawing.
11. A level (CXS) landing area, 5' typical by the width of the ramp throat, shall be required at the top of each Curb Ramp. Slopes shall be designed to CXS directions shown on each detail. The level landing area shall in no cases be less than 4' in any direction. Landings must be provided with or without adjacent sidewalks.

Continued on 7.0b...



City and County of Denver  
Transportation Standards & Details

General Notes for Curb Ramps

Date:  
04/17

Std. Dwg.  
7.0a

## GENERAL NOTES FOR CURB RAMPS

...continued from 7.0a

12. Location of a property designed and located curb ramp shall take precedence over location of a drainage structure or existing obstacle, to the maximum extent practicable. When the effort required to remove, and/or relocate drainage structures or other obstacles exceeds maximum extent practicable, it shall be acceptable to reposition the curb ramp or close the PAR at that location, if approved by PW in writing.
13. All Curb Ramps shall be constructed with tactile warnings (truncated dome panels). Truncated dome panels shall be installed across the full width of the ramp, and set so that the closest point or points are 6" from grade break at bottom of the ramp (flowline).
14. Truncated dome panels shall be brick red, tile red, black when noted, or other equivalent color as approved by PW to provide color contrast with the adjoining ramp or accessible surface. When adjoining sidewalk is flagstone, or when retrofitting truncated dome panels within red concrete, the truncated dome panels shall be black in color to provide required contrast. See Std. Dwg. 7.5 for dome panel colors in Blended Transition ramp application. Concrete for curb ramp construction shall never be stained or have color added.
15. A sample of the truncated domes shall be submitted to, and approved by PW prior to construction. Truncated dome size shall meet ANSI requirements and have non-slip tops. Panels are to be wet set into concrete. Integral anchors may be used if resetting is needed. Truncated dome sections set in a sand or other non-cementitious bed will not be allowed unless approved by PW. Truncated domes may not be stamped into wet concrete. Brick shall not be used for truncated dome panels unless specifically approved in writing by PW.
16. Truncated domes fabricated from non-cementitious material (composite, plastic, etc.) with hollow undersides may not be cut unless approved by PW and the manufacturer. Any proposed cuts must be at and along a rib-line, so whole sections to ribs are set into wet concrete ramp. Any section without ribs shall be cut off and discarded. If solid cementitious or other non-hollow truncated dome panels are cut, the location of the cuts should be positioned to minimize cutting through domes. If domes are cut, the remaining partial domes must be ground off completely. Placement of small cut triangles of truncated dome panels to fill gaps, corners, etc. is not allowed.
17. Curb ramps require fibermesh reinforcement at minimum 1.5 pounds per cubic yard.
18. Any required transition between vertical and mountable curb adjacent to ramps should occur in a maximum of 10'.
19. Pay limits of all ramps are comprised of all area shown with concrete hatching on the applicable details, unless otherwise noted.
20. Coordinate with PW if additional R.O.W. is required to ensure that the curb ramp, including top landing and flares do not extend onto private property.



City and County of Denver  
Transportation Standards & Details

General Notes for Curb Ramps

Date:  
04/17

Std. Dwg.  
7.0b

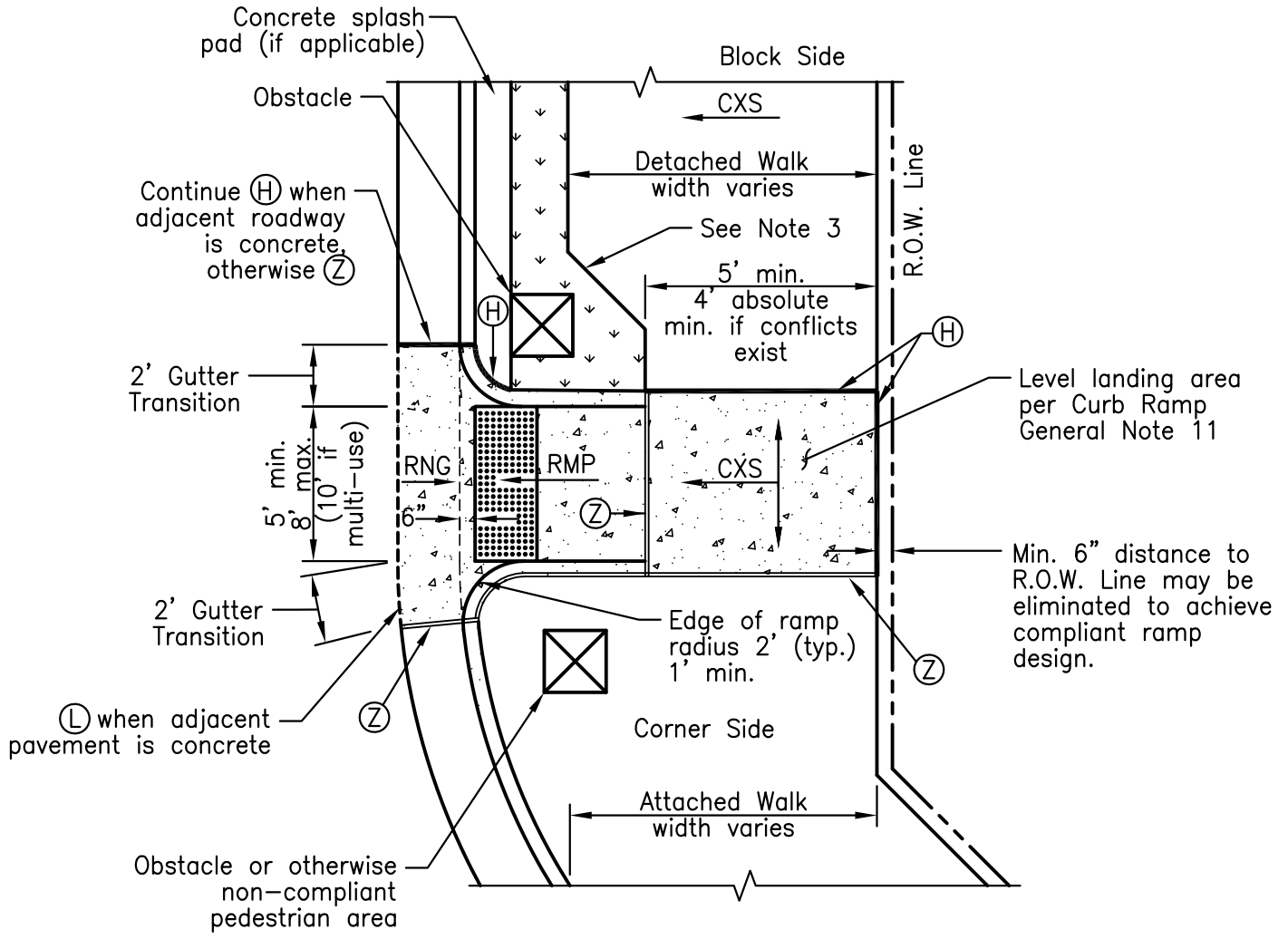

**CURB RAMP – TYPE 1**

**Notes:**

1. Type 1 Ramps shall be used where there is insufficient room for FLR slopes on both sides of the ramp.
2. Typical Curb Ramp installations shall consist of two ramps at each corner, each positioned to cross its leg of the intersection to a receiving ramp. A single ramp placed diagonally may not be used in new construction.
3. Adjacent landscaping/planted strips should transition to the back of Type 1 Curb Ramps. Alternatively, the ramp may be shortened such that its back matches the width of the landscaping, but not so much that a 12:1 maximum slope is exceeded.
4. Contact Office of City Forester at (720)913-0651 prior to performing any work within the drip line of existing R.O.W. trees.

FLR	Accessible Flare Slope = 9.5% (10.0% max)
RMP	Accessible Ramp Slope = 7.8% (8.3% max)
CXS	Accessible Cross Slope = 1.5% (2.0% max)
RNG	Accessible Running Slope = 5.0% max

	City and County of Denver Transportation Standards & Details	Date: 04/17
	Curb Ramp Type 1	Std. Dwg. 7.1

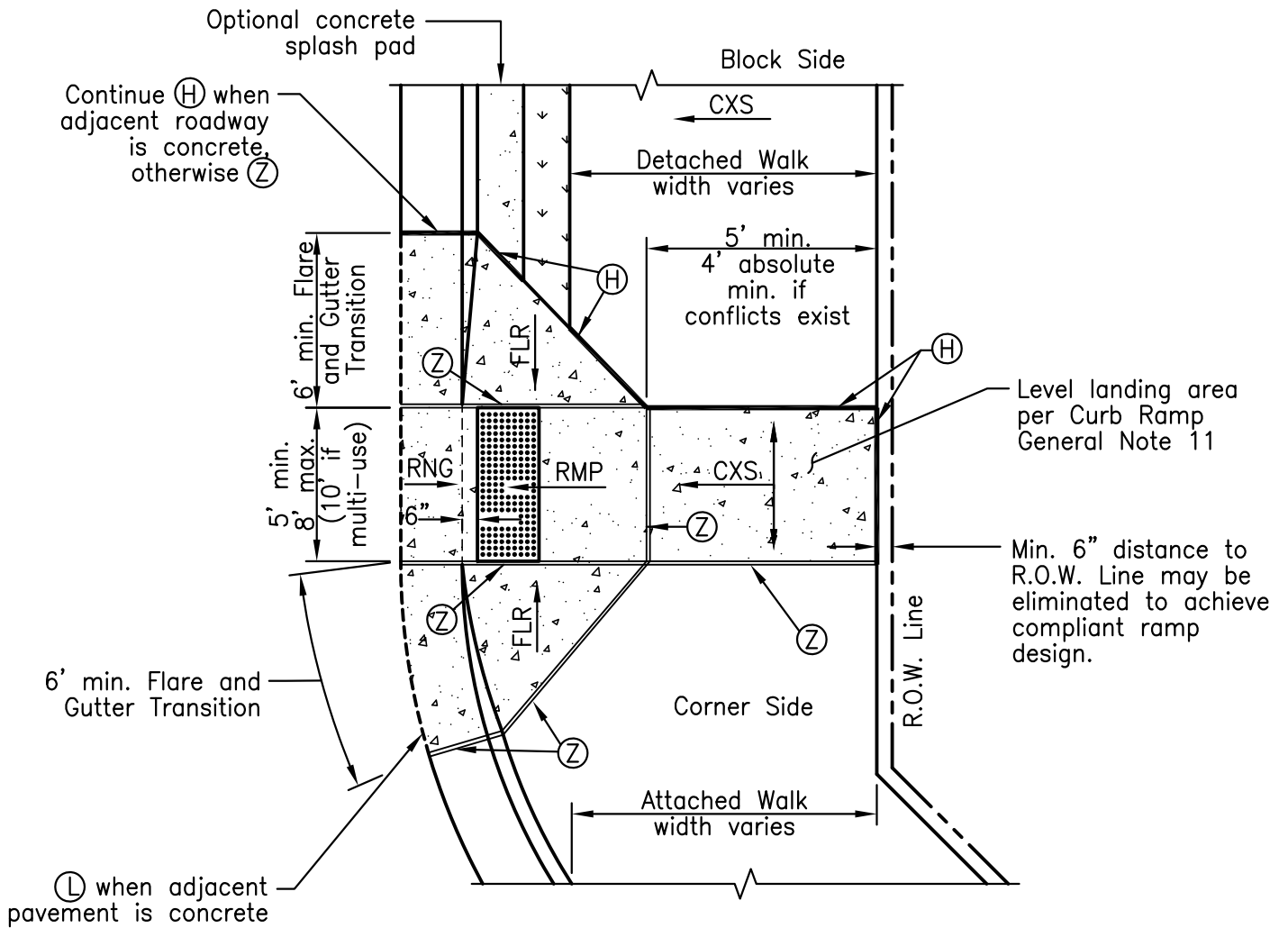

### CURB RAMP – TYPE 2

**Notes:**

1. A Type 2 Curb Ramp shall be used where there is sufficient room for FLR slopes as depicted on this Std. Dwg., on both sides of the ramp.
2. Typical Curb Ramp installations shall consist of two ramps at each corner, each positioned to cross its leg of the intersection to a receiving ramp. A single ramp placed diagonally should not be used in new construction.
3. Contact Office of City Forester at (720)913-0651 prior to performing any work within the drip line of existing R.O.W. trees.

FLR	Accessible Flare Slope = 9.5% (10.0% max)
RMP	Accessible Ramp Slope = 7.8% (8.3% max)
CXS	Accessible Cross Slope = 1.5% (2.0% max)
RNG	Accessible Running Slope = 5.0% max



City and County of Denver  
Transportation Standards & Details

Curb Ramp Type 2

Date:  
04/17

Std. Dwg.  
7.2a

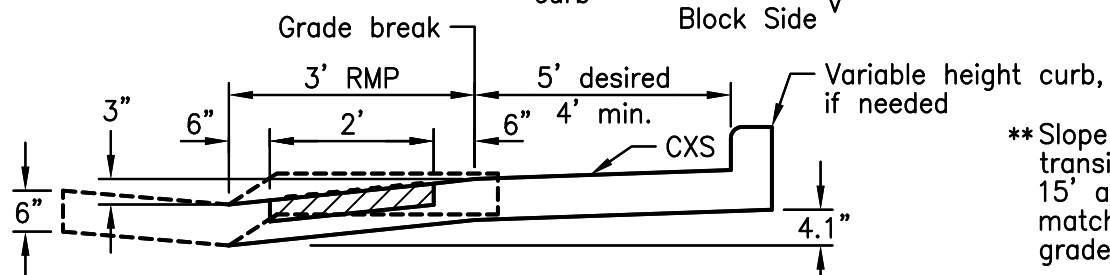
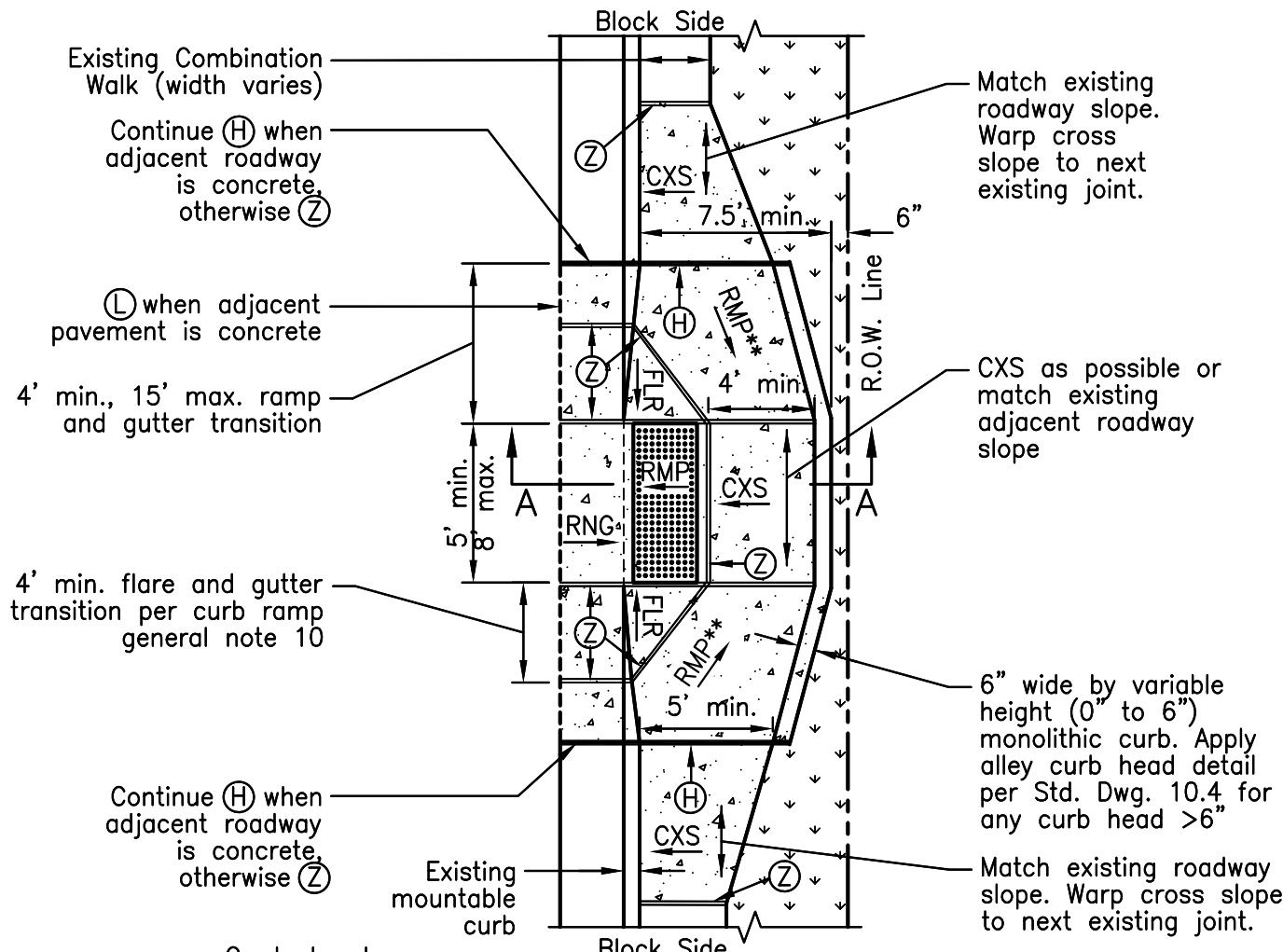

\*\*Slope may exceed RMP if transition length has reached 15' and the ramp has not yet matched existing matching grade. See Std. Dwg. 7.7

SECTION A-A

FLR	Accessible Flare Slope = 9.5% (10.0% max)
RMP	Accessible Ramp Slope = 7.8% (8.3% max)
CXS	Accessible Cross Slope = 1.5% (2.0% max)
RNG	Accessible Running Slope = 5.0% max

Notes:

1. A Modified Curb Ramp may be used in retrofit situations wherever there are existing obstructions or inadequate R.O.W. width at the intersection of existing residential streets to provide a Type 1, 2, or 3 Curb Ramp. It may also be used at mid block locations when allowed.
2. Typical Curb Ramp installations shall consist of two ramps at each corner, each positioned to cross its leg of the intersection to a receiving ramp. A single ramp placed diagonally should not be used in new construction.
3. Contact Office of City Forester at (720)913-0651 prior to performing any work within the drip line of existing R.O.W. trees.
4. All grade breaks should be aligned with (H) or (Z) joints.

	City and County of Denver Transportation Standards & Details	Date: 04/17
	Curb Ramp Type 2 Modified (For Combination Curb, Gutter and Sidewalk)	Std. Dwg. 7.2b



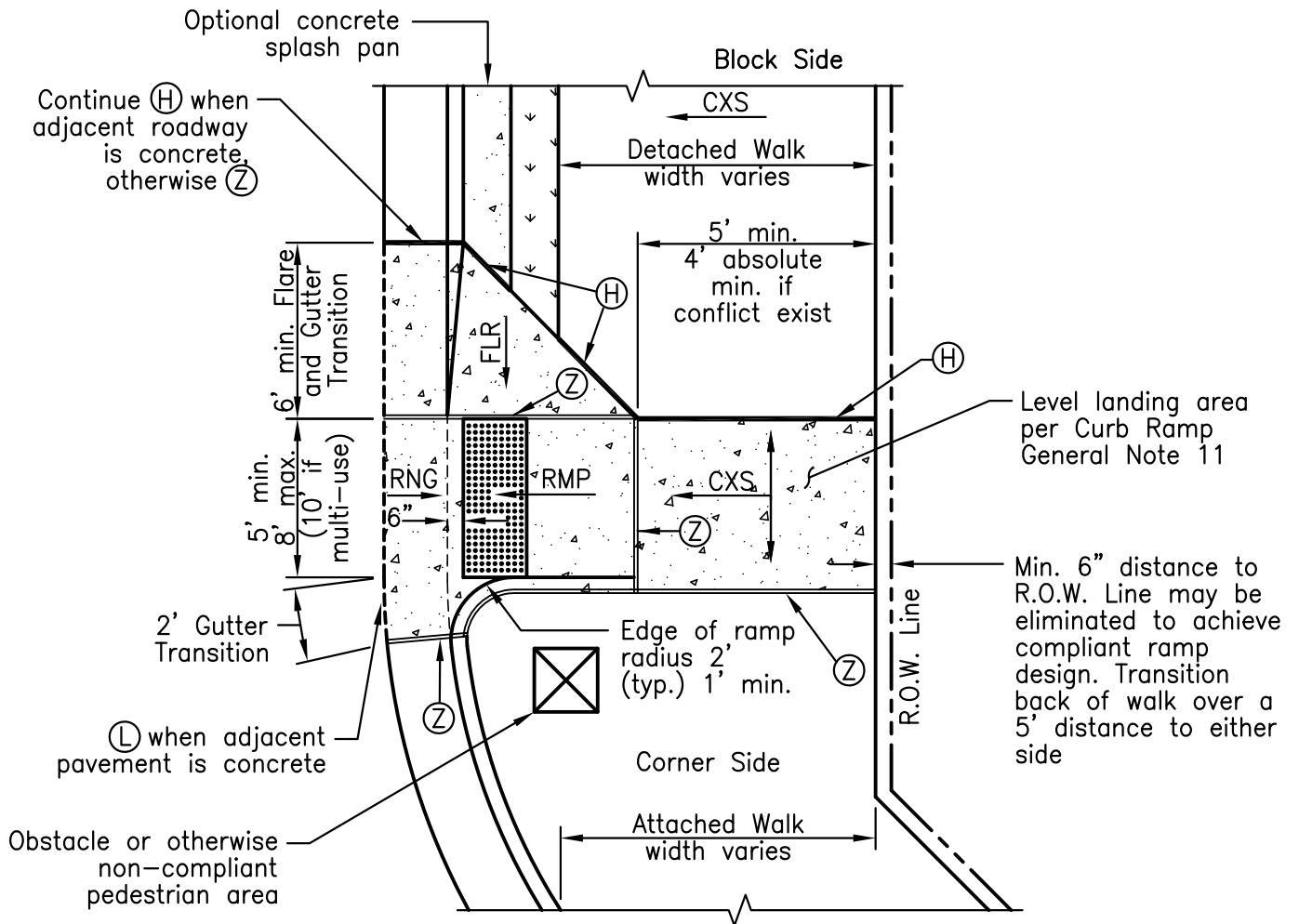

### CURB RAMP - TYPE 3

**Notes:**

1. A Type 3 Curb Ramp shall be used where there is insufficient room for a compliant flare on one side of the ramp.
2. Typical Curb Ramp installations shall consist of two ramps at each corner, each positioned to cross its leg of the intersection to a receiving ramp. A single ramp placed diagonally may not be used in new construction.
3. Contact Office of City Forester at (720)913-0651 prior to performing any work within the drip line of existing R.O.W. trees.

FLR	Accessible Flare Slope = 9.5% (10.0% max)
RMP	Accessible Ramp Slope = 7.8% (8.3% max)
CXS	Accessible Cross Slope = 1.5% (2.0% max)
RNG	Accessible Running Slope = 5.0% max



City and County of Denver  
Transportation Standards & Details

Curb Ramp Type 3

Date:  
04/17

Std. Dwg.  
7.3

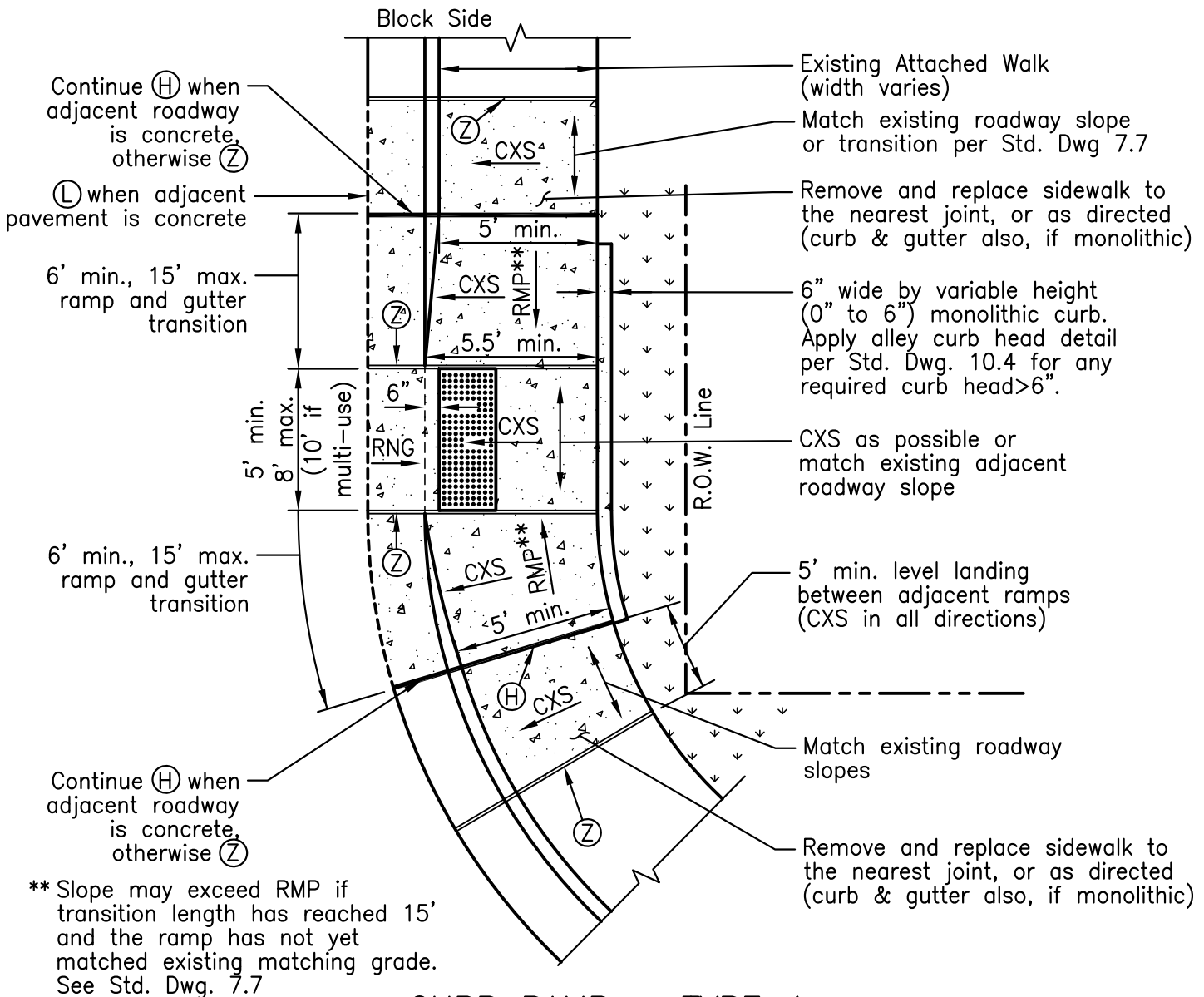

**CURB RAMP – TYPE 4**

- Notes:
1. A Type 4 Curb Ramp may be used in retrofit situations wherever there are existing obstructions or inadequate R.O.W. width at the intersection of existing residential streets to provide a Type 1, 2, or 3 Curb Ramp.
  2. Typical Curb Ramp installations shall consist of two ramps at each corner, each positioned to cross its leg of the intersection to a receiving ramp.
  3. Any proposed single ramp placed diagonally at a corner will only be considered in retrofit situations at the intersection of existing residential streets, and must specifically be approved by PW in writing.
  4. Contact Office of City Forester at (720)913-0651 prior to performing any work within the drip line of existing R.O.W. trees.

FLR	Accessible Flare Slope = 9.5% (10.0% max)
RMP	Accessible Ramp Slope = 7.8% (8.3% max)
CXS	Accessible Cross Slope = 1.5% (2.0% max)
RNG	Accessible Running Slope = 5.0% max

	<p>City and County of Denver Transportation Standards &amp; Details</p>	<p>Date: 04/17</p>
	<p>Curb Ramp Type 4</p>	<p>Std. Dwg. 7.4</p>

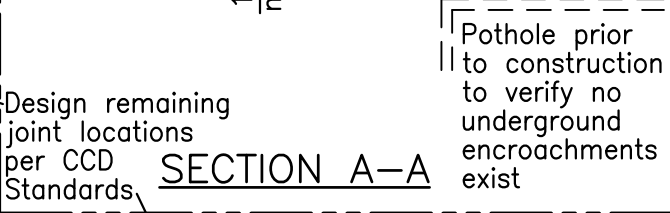
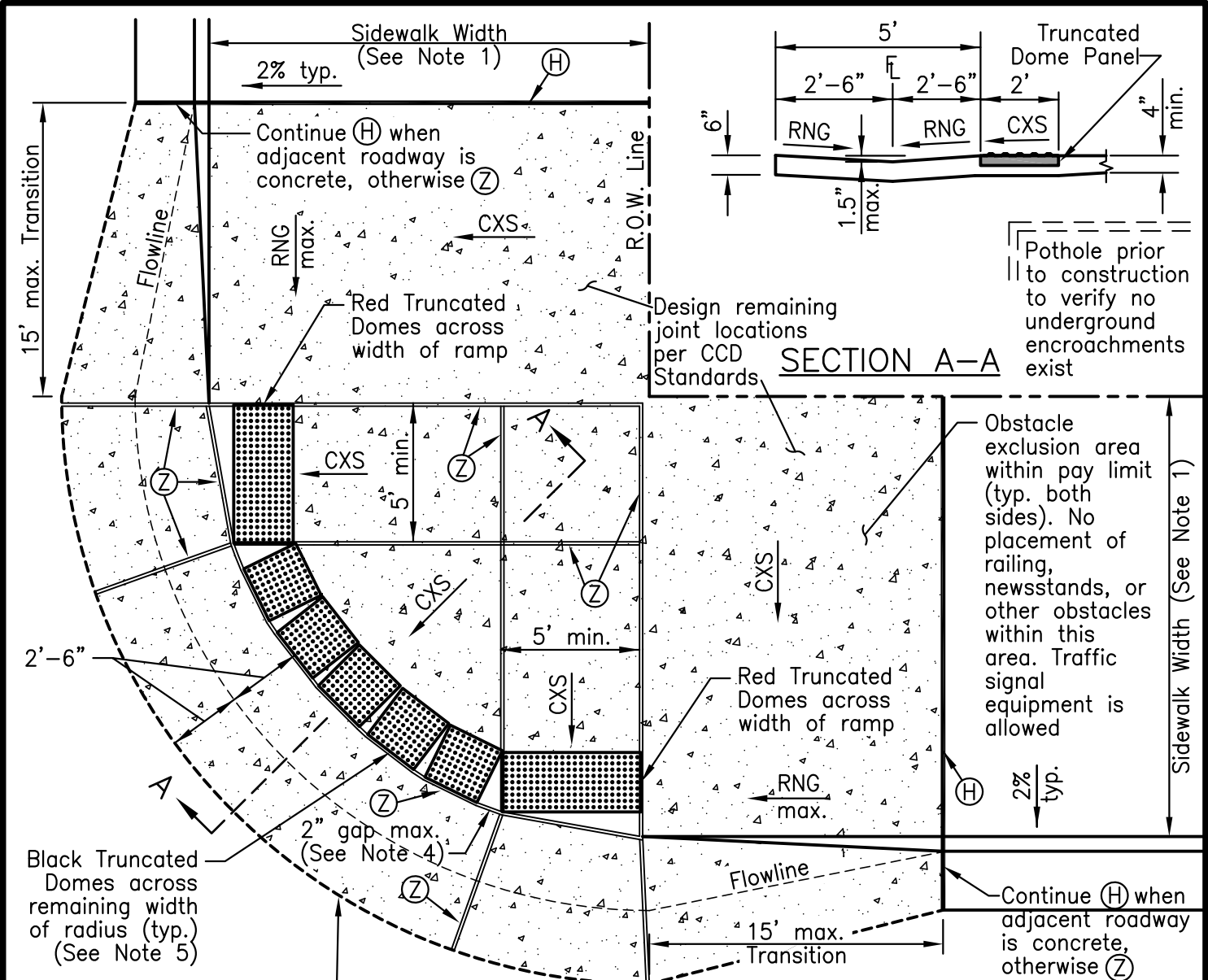

FLR	Accessible Flare Slope = 9.5% (10.0% max)
RMP	Accessible Ramp Slope = 7.8% (8.3% max)
CXS	Accessible Cross Slope = 1.5% (2.0% max)
RNG	Accessible Running Slope = 5.0% max

Notes:

1. If existing sidewalk widths are different, match the smallest width, to 5' minimum.
2. For construction adjacent to existing asphalt streets, refer to Std. Dwg. 12.0.
3. Slopes shown as typical on section A-A may be adjusted if necessary to fit existing conditions, but must meet RNG slope in all situations.
4. Black truncated dome panels shall be placed so that the triangular gap on the street side between panels is no wider than 2". Radial panels are recommended where possible. Panels may be trimmed to reduce this gap (per Curb Ramp General Note 16) or the width of panels may be adjusted to meet the 2" maximum gap. Panels that are less than 2' wide must be approved by PW.
5. Black truncated dome panels proposed in cast iron material shall be asphalt-dipped for black color. Black truncated dome panels proposed for approval by PW in all other materials shall be ultraviolet and weather/wear resistant to maintain long-term color contrast.
6. All truncated dome panels proposed for placement at the same corner shall be made of uniform material. Therefore, when cast iron panels are used, red panels shall also be placed in cast iron.

	City and County of Denver Transportation Standards & Details	Date: 04/17
	Downtown Signalized Corner Blended Transition	Std. Dwg. 7.5

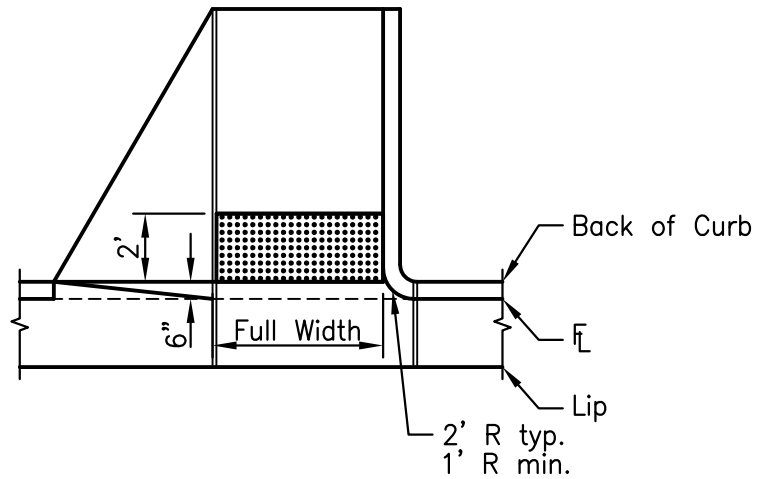

OPTION 1

Apply when edge of ramp closest to intersection is located either at or outside of corner Point of Curb Return

>> IF CANNOT INSTALL, MOVE TO OPTION 2 <<

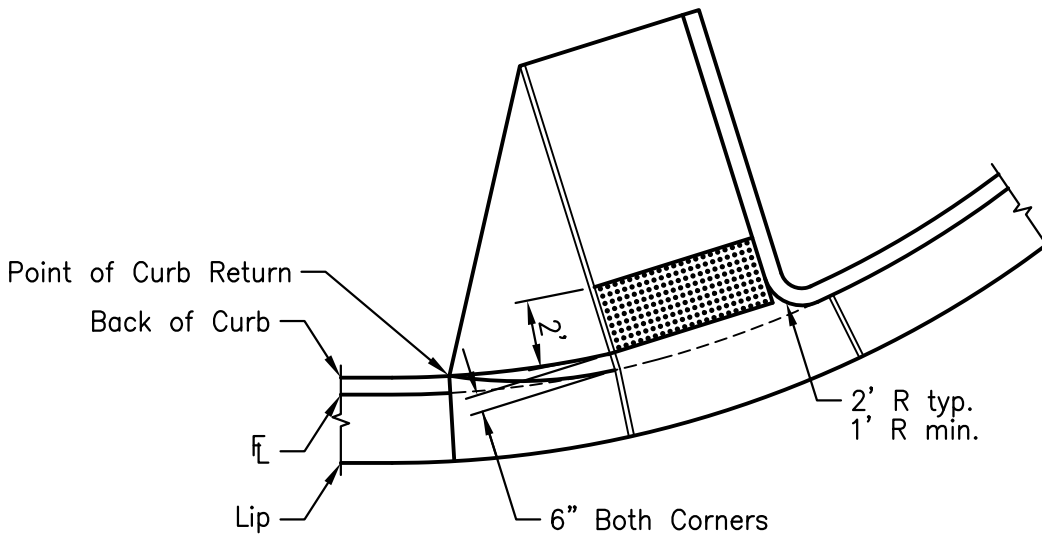

OPTION 2

Apply when inside edge of ramp closest to intersection is located either at or Inside of corner Point of Curb Return

>> IF CANNOT INSTALL, MOVE TO OPTION 3 <<



City and County of Denver  
Transportation Standards & Details

Curb Ramp Truncated Dome  
Placement Options

Date:  
04/17

Std. Dwg.  
7.6a

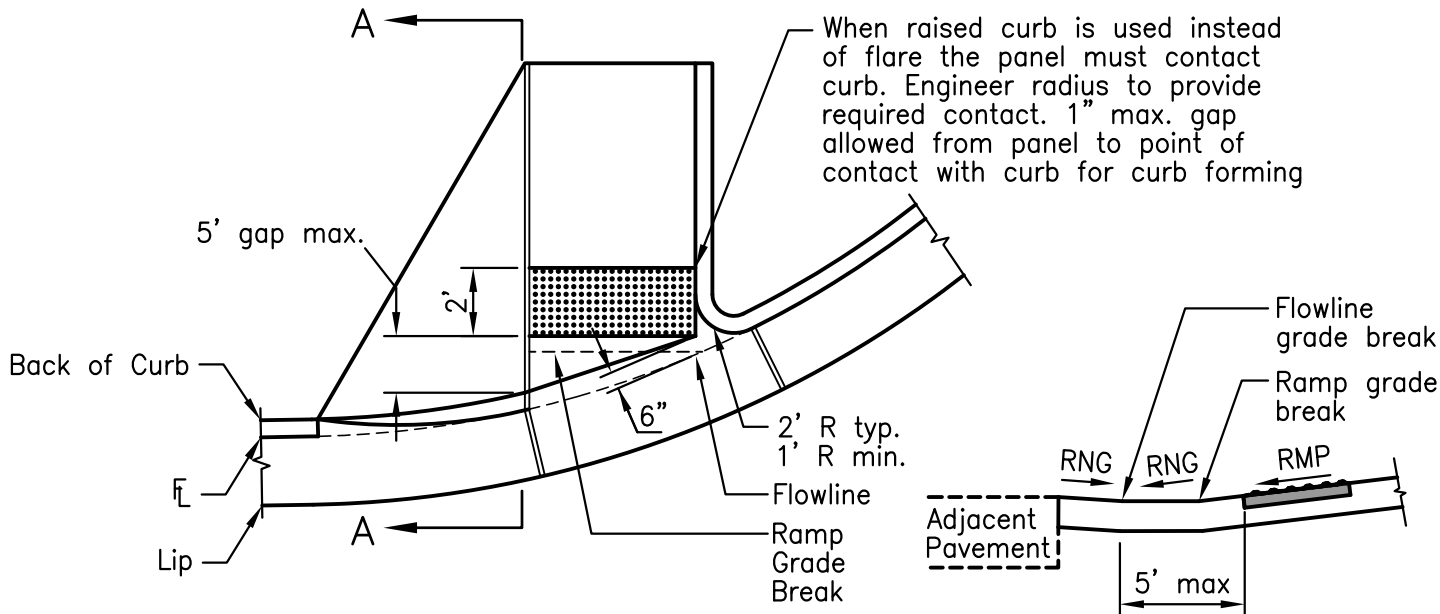

**OPTION 3**

**SECTION A-A**

Ramp Dome Placement when ramp is not aligned perpendicular to curb/flowline

>> IF CANNOT INSTALL, MOVE TO OPTION 4 <<

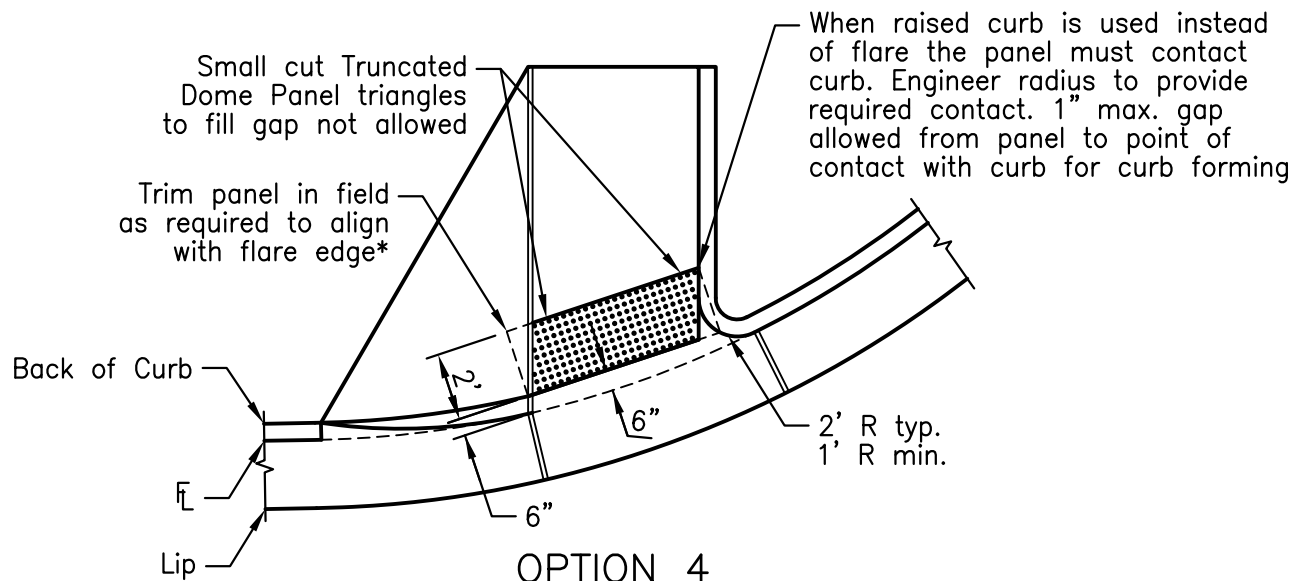

**OPTION 4**

Ramp Dome Placement when ramp is not aligned perpendicular to curb/flowline

\*Refer to note 16 on Std. Dwg. 7.0b

	City and County of Denver Transportation Standards & Details	Date: 04/17
	Curb Ramp Truncated Dome Placement Options	Std. Dwg. 7.6b

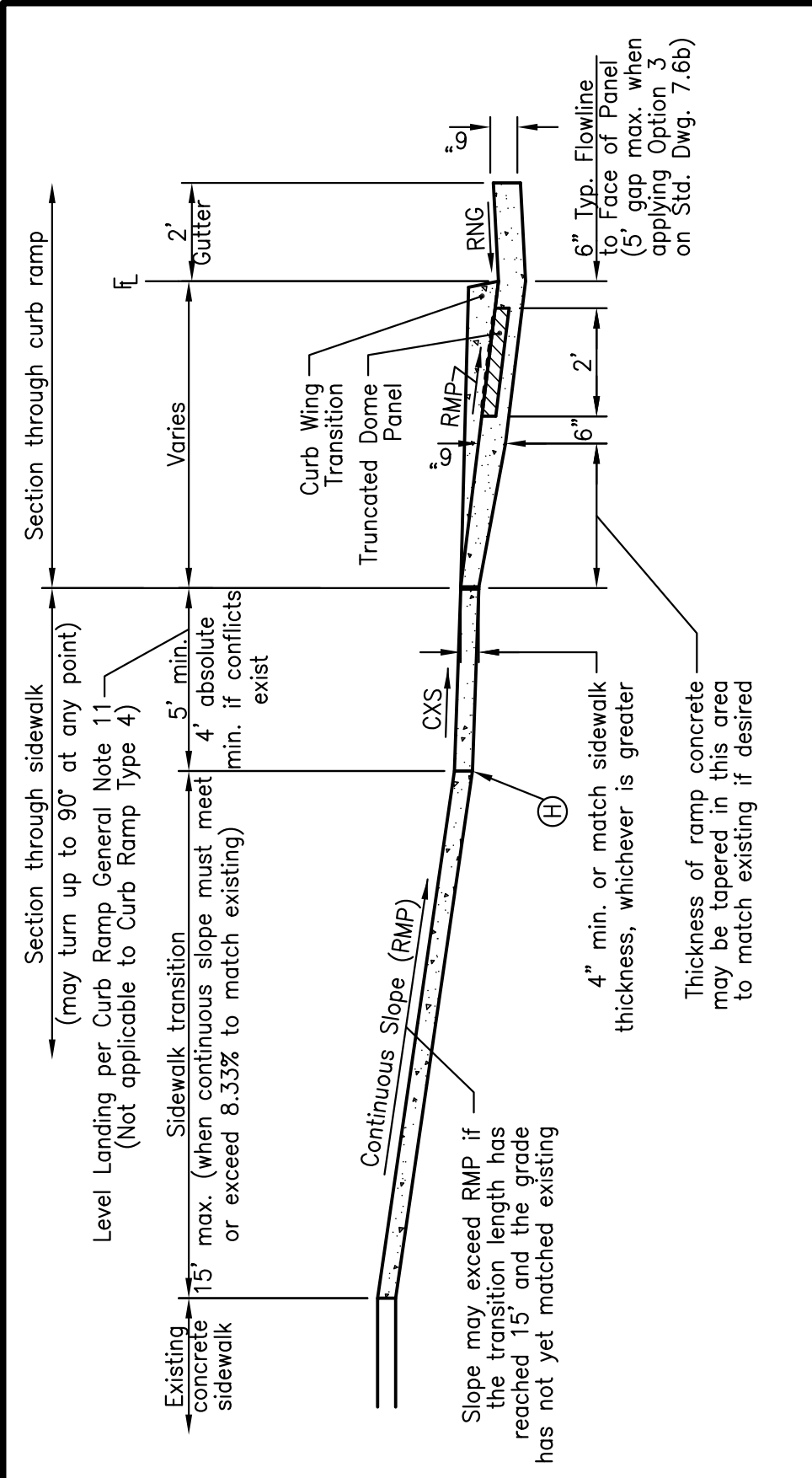

**TYPICAL CURB RAMP CROSS-SECTION**

Notes:  
 1. Contact Office of City Forestry at (720)913-0651 prior to performing any work within the drip line of existing R.O.W. trees.

- FLR Accessible Flare Slope = 9.5% (10.0% max)
- RMP Accessible Ramp Slope = 7.8% (8.3% max)
- CXS Accessible Cross Slope = 1.5% (2.0% max)
- RNG Accessible Running Slope = 5.0% max



City and County of Denver  
 Transportation Standards & Details  
 Curb Ramp Typical Section

Date:  
 04/17  
 Std. Dwg.  
 7.7

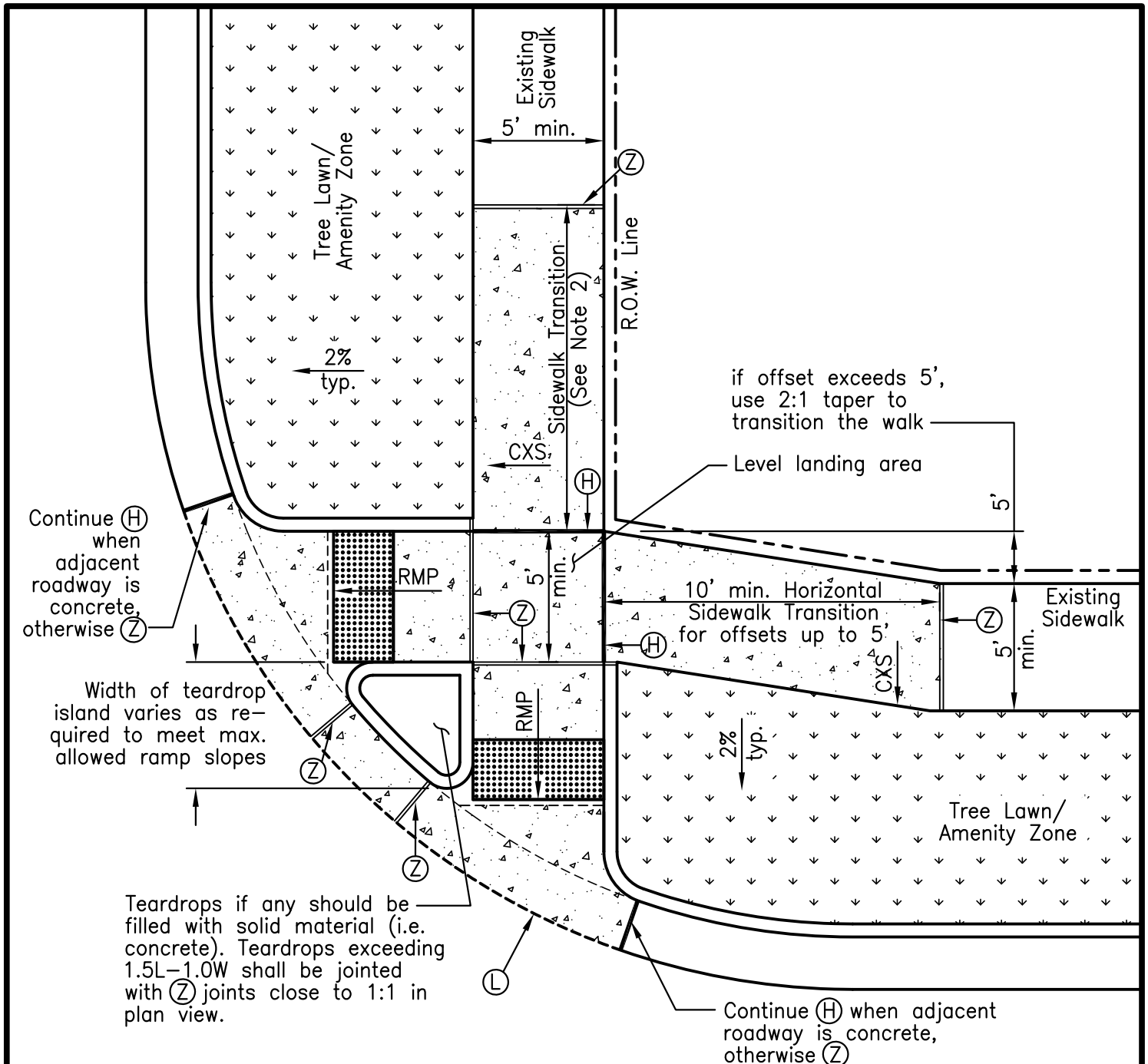

Notes:

1. To allow required ramp length to meet maximum allowed slopes, sidewalks leading up to curb ramps may be offset as shown.
2. Sidewalk transition length need not exceed 15', but long slope must be uniform. See Std. Dwg. 7.7 for additional information.
3. Complete jointing details are not included on this drawing.
4. Ramps and landing area must be poured monolithically.

FLR	Accessible Flare Slope = 9.5% (10.0% max)
RMP	Accessible Ramp Slope = 7.8% (8.3% max)
CXS	Accessible Cross Slope = 1.5% (2.0% max)
RNG	Accessible Running Slope = 5.0% max



City and County of Denver  
Transportation Standards & Details

Typical Sidewalk Transitions to  
Curb Ramp Landing

Date:  
04/17

Std. Dwg.  
7.8

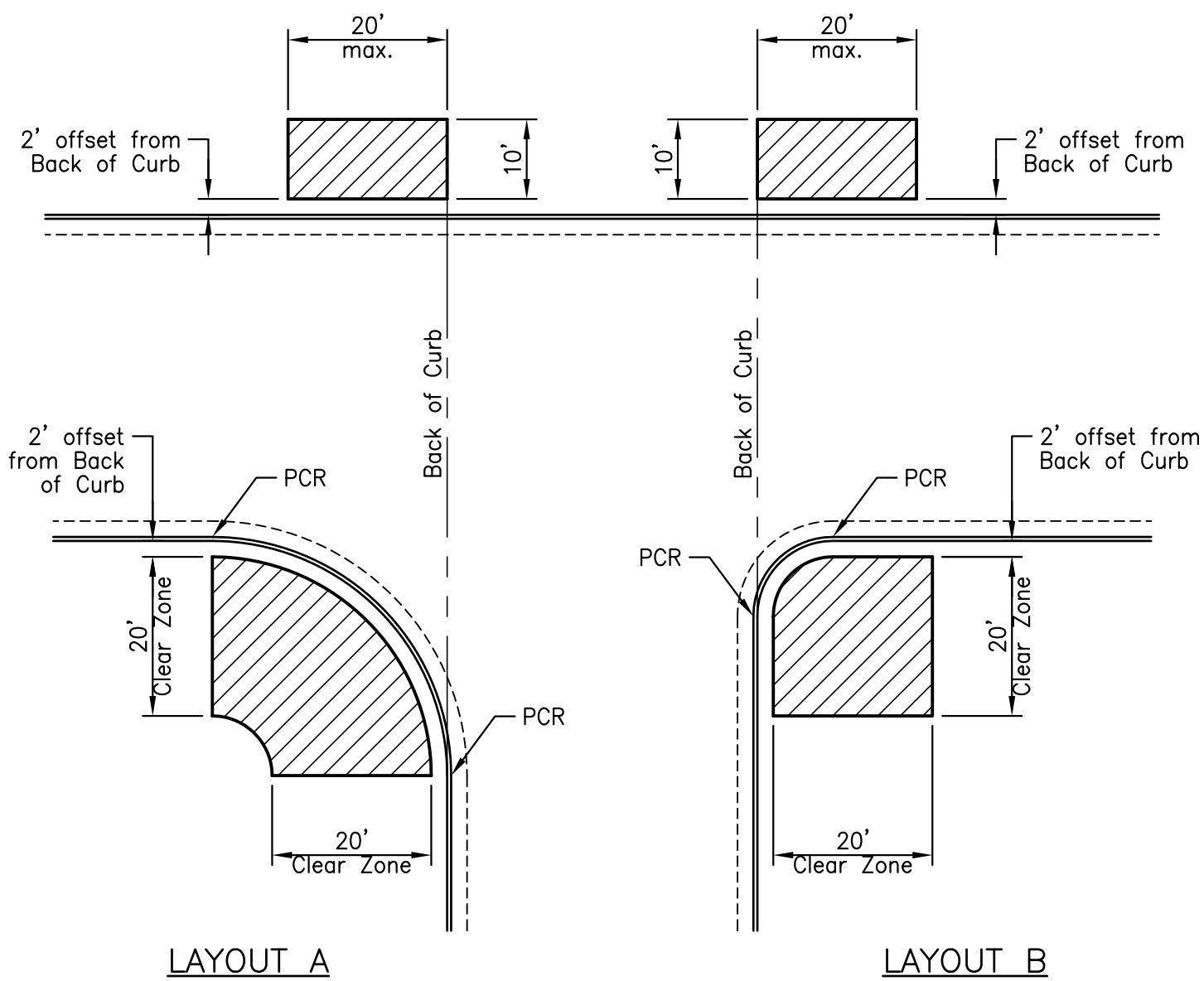

LAYOUT A

LAYOUT B

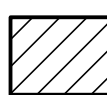
 Maintain a 20' "Clear Zone" at intersections for the installation of future Traffic Signal Equipment. Do not engineer or place permanent vertical or utility obstructions within this area.

Notes:

1. When the flowline radius is greater than 22'-6", use Layout A.
2. When the flowline radius is 22'-6" or less, use Layout B.
3. The clear zone does not apply outside of R.O.W.

	City and County of Denver Transportation Standards & Details	Date: 04/17
	Signal Equipment Clear Zone	Std. Dwg. 7.9



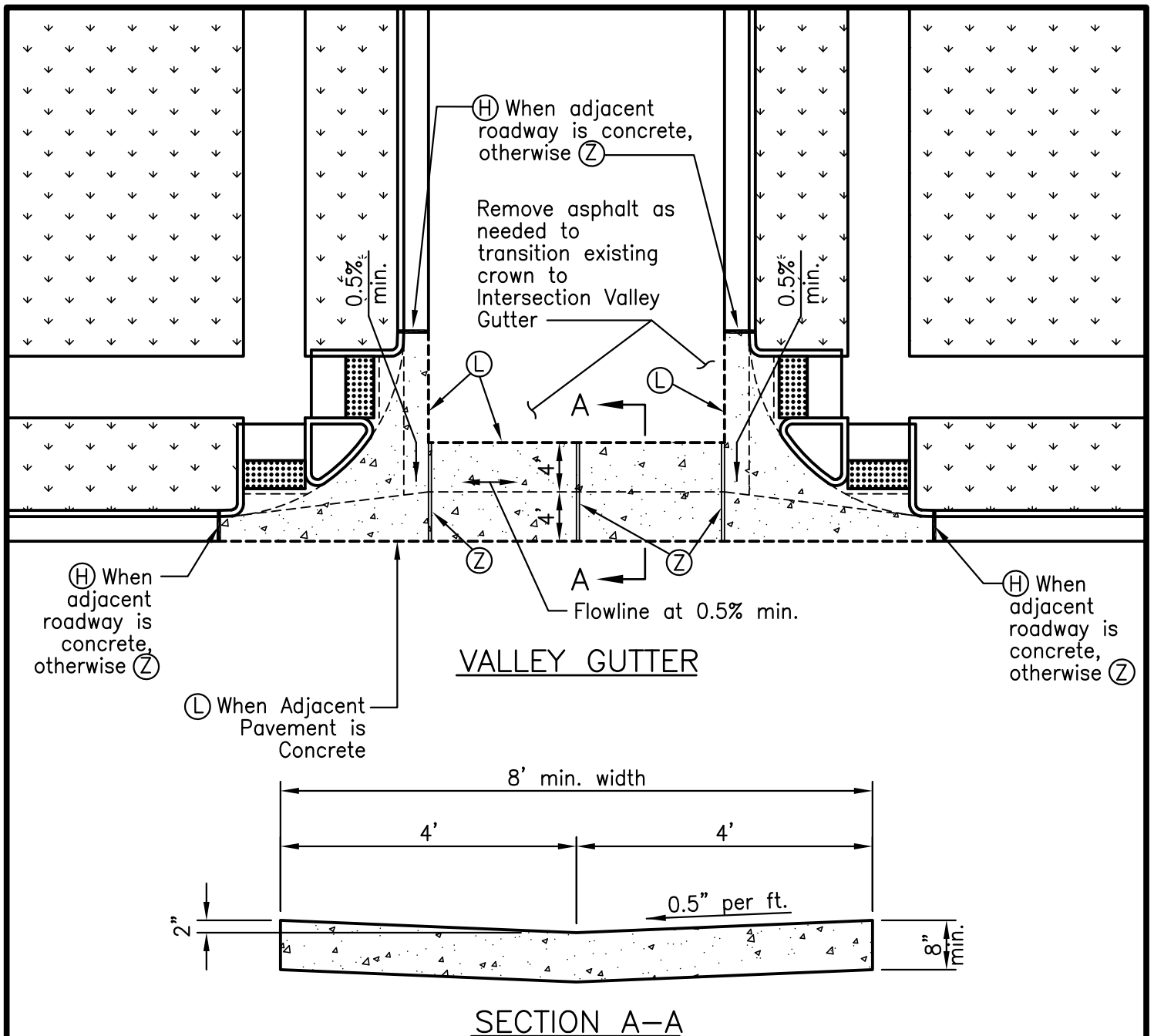

Notes:

1. This Standard Drawing shall only be used for the replacement of existing Intersection Valley Gutters, or where existing street grades necessitate their use. Intersection Valley Gutters should not be used in areas of new street construction. Intersection Valley Gutters may not cross arterial, collector, or streets with bike lanes without approval of PW.
2. Intersection valley gutters may only be placed when approved in writing by PW.
3. Valley gutter cross-pan requires fibermesh reinforcement at minimum 1.5 pounds per cubic yard.



City and County of Denver  
 Transportation Standards & Details

Intersection Valley Gutter

Date:  
 04/17

Std. Dwg.  
 8.0

Transition to end of plate as necessary

Remove additional curb & gutter to maintain 2' min. adjacent curb & gutter section or directed by PW

Retaining Screw @ 1' o.c. or as approved by PW

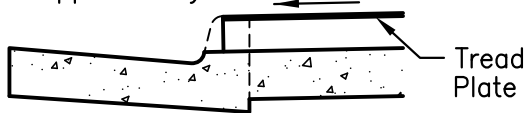

6" Vertical Curb, Gutter, and Sidewalk

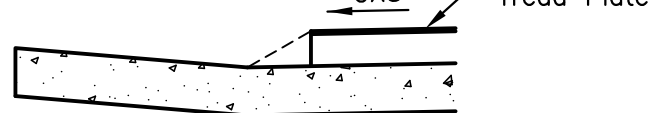

Combination Curb, Gutter, and Sidewalk

**PLAN VIEW**

**SECTION A-A (2 VIEWS)**

Variable. Max. allowable span: 1' for 0.375" Plate and 2' for 0.5" Plate

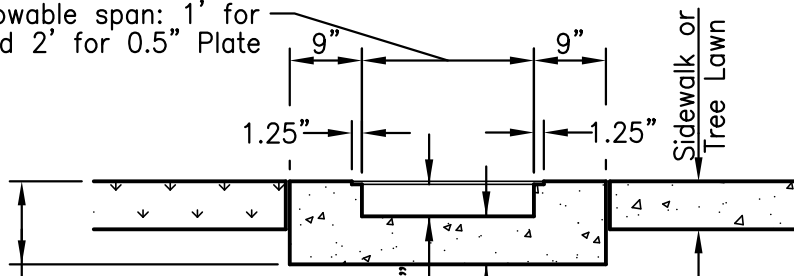

**SECTION B-B**

10.375" OR 10.5" when 0.5" tread plate is used

Tread Plate: 0.375" to 0.5" rolled-steel diamond pattern. Dimension variable

L = 1.25" x 1.25" x 0.5"

Concrete anchors welded to angle iron (typ.)

Anchor type may vary

0.375" or 0.5" Rolled Galvanized Steel Tread Plate

0.5"Ø x 1" Flat Head Machine Screw, Brass or Electro-galv. finish

Angle iron to be drilled and tapped to receive screw

Concrete to be drilled to allow screw (typ. both sides)

**SECTION C-C**

**Notes:**

1. Length of steel plate varies.
2. Chase and cover plate run perpendicularly from Property Line to flowline unless approved by PW.
3. Chase and curb & gutter to be placed monolithically. Sidewalk to be placed separately.
4. Contact Office of City Forester at (720)913-0651 prior to performing any work within the drip line of existing R.O.W. trees.

	City and County of Denver Transportation Standards & Details	Date: 04/17
	Sidewalk Chase Drain and Tread Plate	Std. Dwg. 8.1

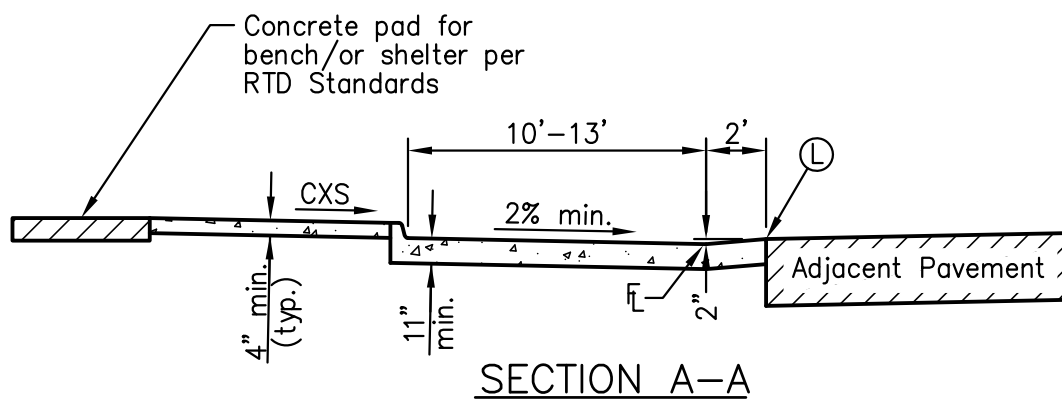
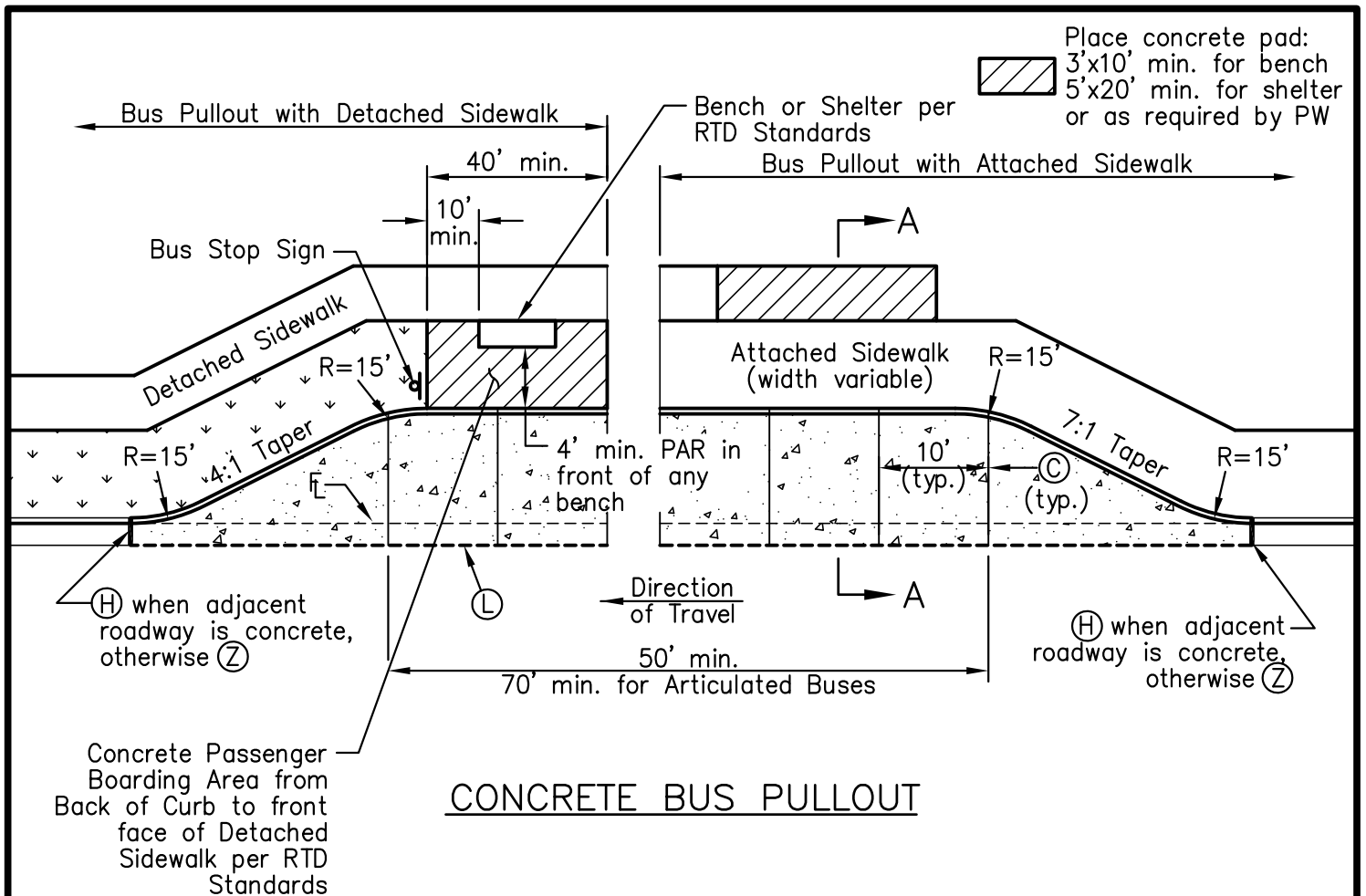

Notes:

1. Length of bus pullout pad may vary to fit site conditions or as otherwise required by RTD standards.
2. All projects that have a bus stop adjacent must provide a concrete bus pad or bus pullout, and a passenger boarding area or shelter pad. The passenger boarding area or passenger shelter pad shall be located in the R.O.W. or appropriate easement. The shelter pad, passenger boarding area, and bench shall be installed and maintained by the land owner directly adjacent.
3. Concrete bus pullout requires fibermesh reinforcement at minimum 1.5 pounds per cubic yard.
4. Contact Office of City Forester at (720)913-0651 prior to performing any work within the drip line of existing R.O.W. trees.
5. All boarding areas must connect to an accessible curb ramp (typically at nearest corner).

	City and County of Denver Transportation Standards & Details	Date: 04/17
	Typical Concrete Bus Pullout	Std. Dwg. 9.0

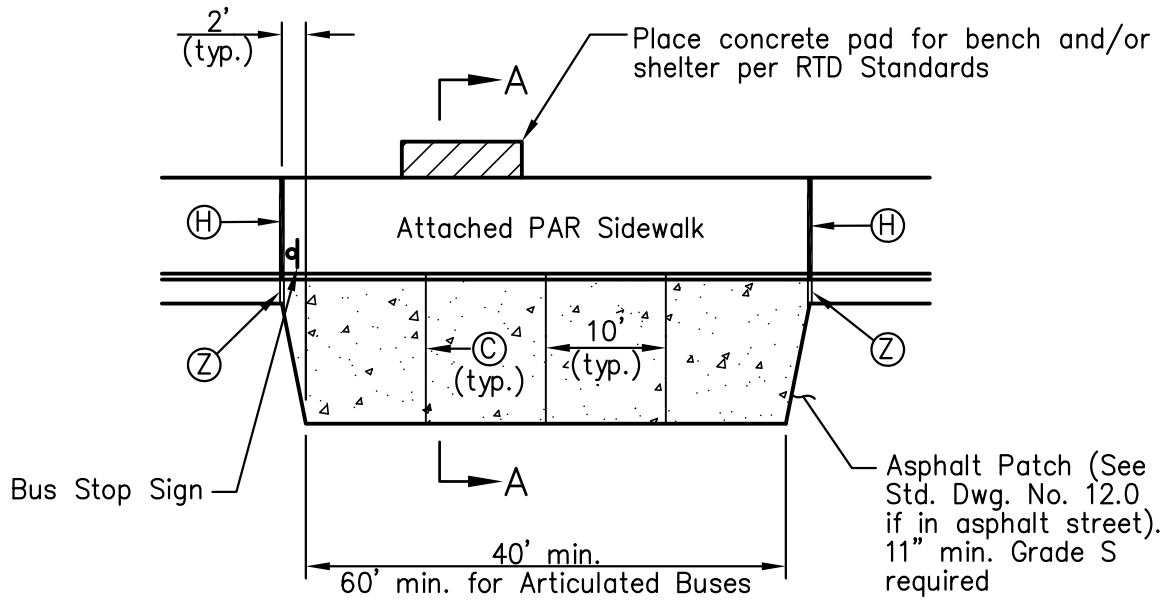

CONCRETE BUS PAD  
IN ASPHALT STREET

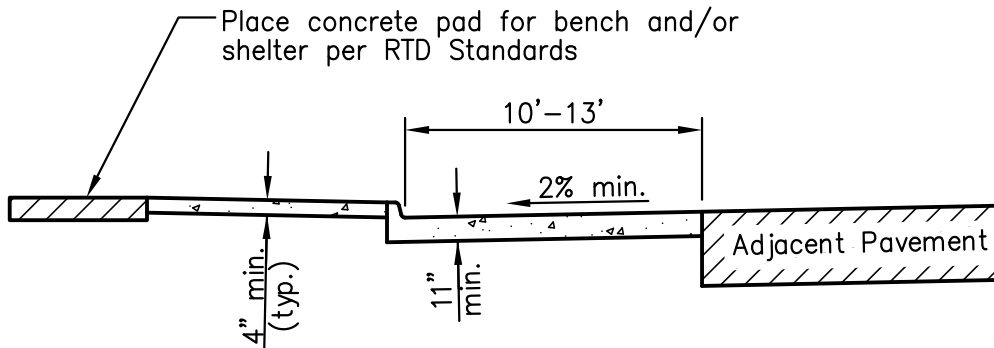

SECTION A-A

Notes:

1. Length of bus pullout pad may vary to fit site conditions or as otherwise required by RTD Standards.
2. Edge of concrete bus pad shall be designed outside of travel lane wheel path.
3. All projects that have a bus stop adjacent must provide a concrete bus pad or bus pullout, and a passenger boarding area or shelter pad. The passenger boarding area or passenger shelter pad shall be located in the R.O.W. or appropriate easement. The shelter pad, passenger boarding area, and bench shall be installed and maintained by the land owner directly adjacent.
4. Concrete bus pads require fibermesh reinforcement at minimum 1.5 pounds per cubic yard.
5. Contact Office of City Forester at (720)913-0651 prior to performing any work within the drip line of existing R.O.W. trees.



City and County of Denver  
Transportation Standards & Details

Typical Concrete Bus Pad in  
Asphalt Roadway

Date:  
04/17

Std. Dwg.  
9.1

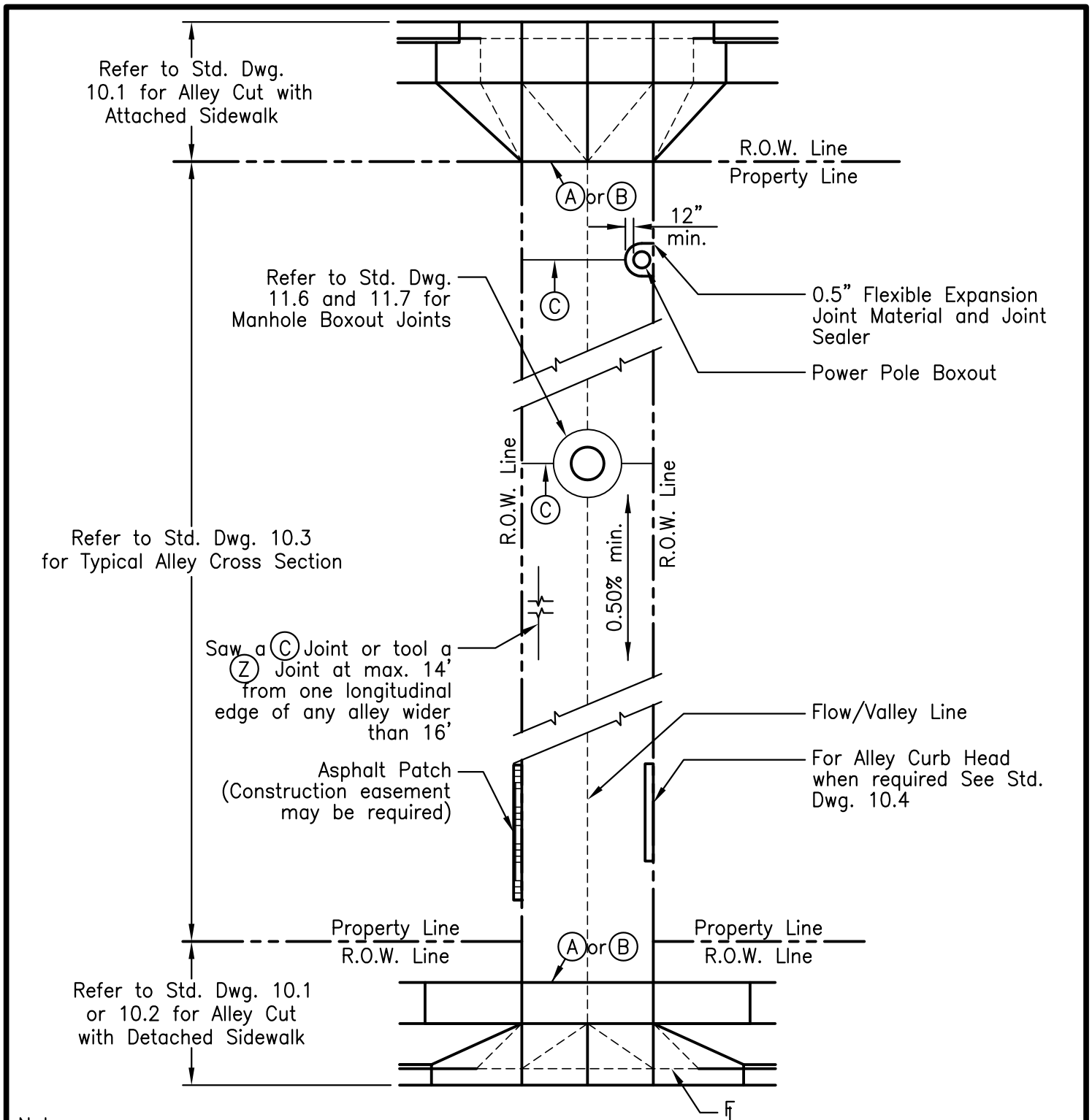

Notes:

1. 0.75" Sealed Expansion Joint shall be placed at those locations where alley changes direction ("T" or "L" shaped alleys) and where adjacent to abutting buildings.
2. Transverse Contraction Joints (C) shall be spaced at a maximum of 15' intervals and placed at manholes, poles, and ends of curb head or as directed by PW. (see Std. Dwg. 11.8).
3. Jointing plan for alley construction shall be approved by PW.
4. Dead-end alleys are not allowed.
5. Requests for any new alleys must be approved by PW.



City and County of Denver  
Transportation Standards & Details

Typical Alley Layout

Date:  
04/17

Std. Dwg.  
10.0

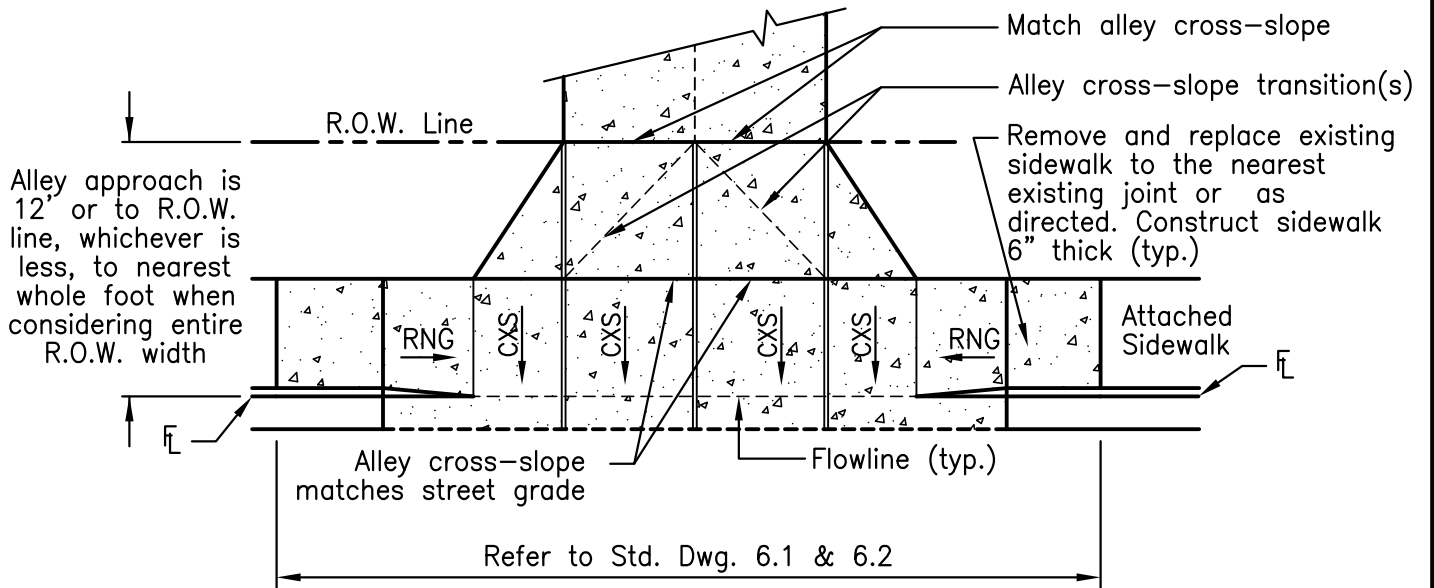

### ALLEY CUT (WITH ATTACHED SIDEWALK)

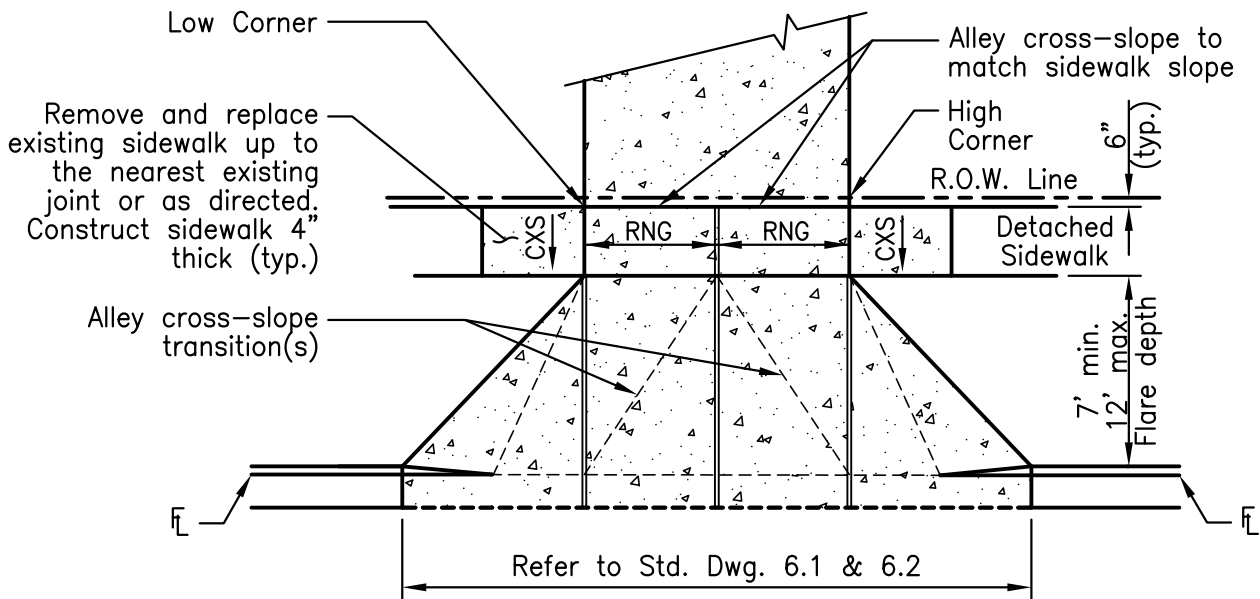

### ALLEY CUT (WITH DETACHED SIDEWALK)

**Notes:**

1. Refer to Std. Dwg. 6.1 and 6.2 for additional slope, joint, transition and cross section details.
2. Alley, sidewalks that cross the alley, and alley approach concrete thickness shall be 8" minimum.
3. Approach widening may be modified for areas with adjacent curb cuts only with approval of PW.
4. Site conditions may require replacement of the adjacent sidewalk outside alley limits in order to meet alley grades.



City and County of Denver  
Transportation Standards & Details

Alley Cut

Date:  
04/17

Std. Dwg.  
10.1

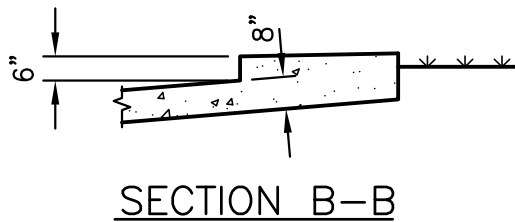
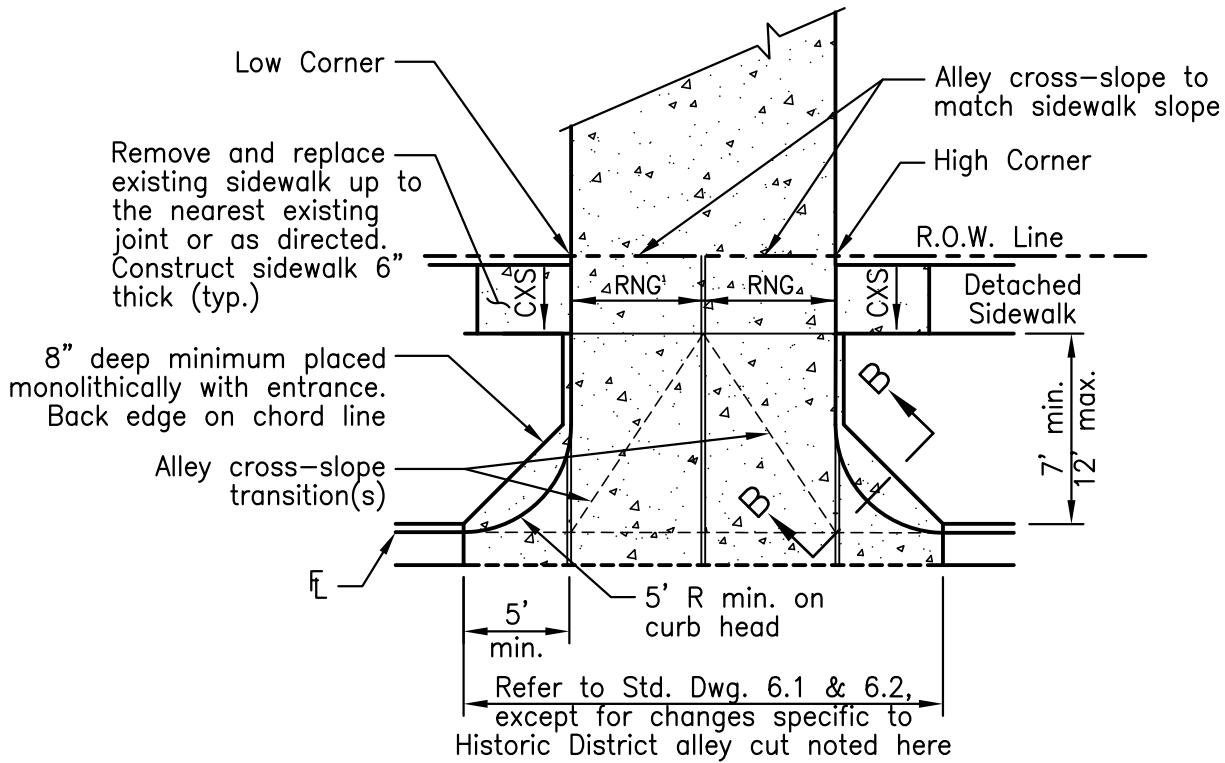

Notes:

1. Any sidewalk sections remaining or replaced must be larger than 4'x4'.
2. Alley, sidewalks that cross the alley, and alley approach concrete paving thickness shall be 8" minimum.
3. Approach widening may be modified for areas with adjacent curb cuts only with approval of PW.
4. Site conditions may require replacement of the adjacent sidewalk outside alley limits in order to meet alley grades.



City and County of Denver  
Transportation Standards & Details

Alley Cut (Historic District)

Date:  
04/17

Std. Dwg.  
10.2

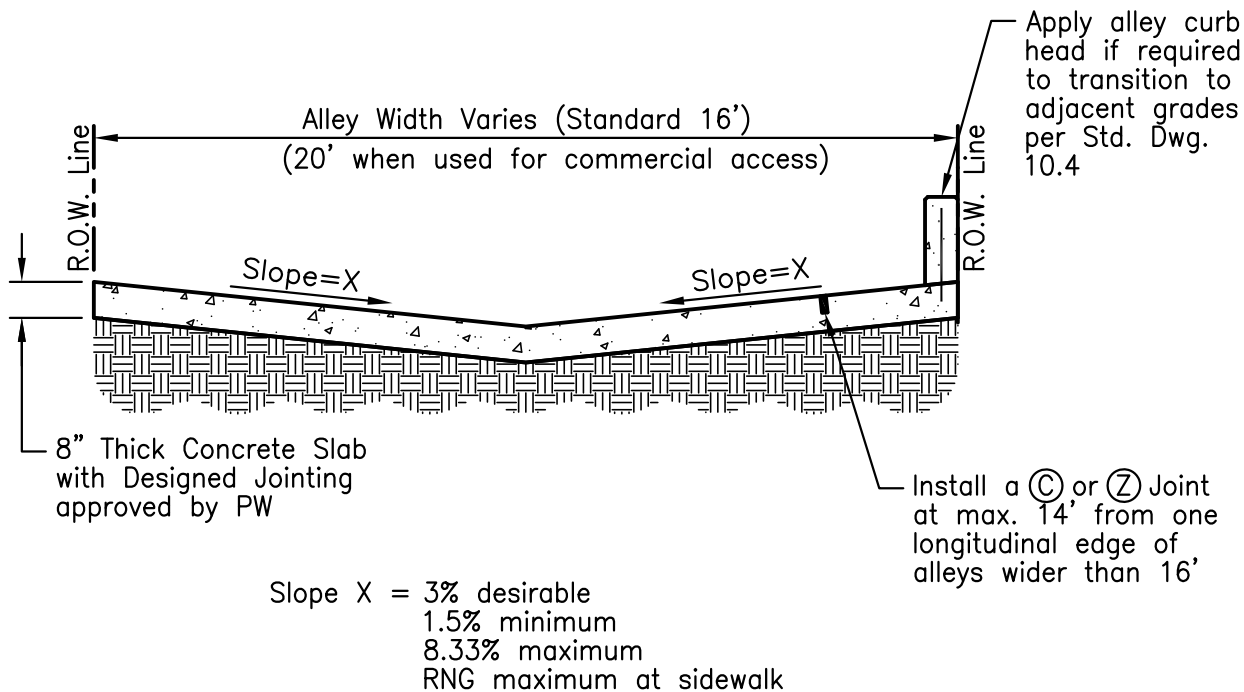

TYPICAL ALLEY CROSS-SECTION



City and County of Denver  
Transportation Standards & Details

Typical Alley Cross-Section

Date:  
04/17

Std. Dwg.  
10.3



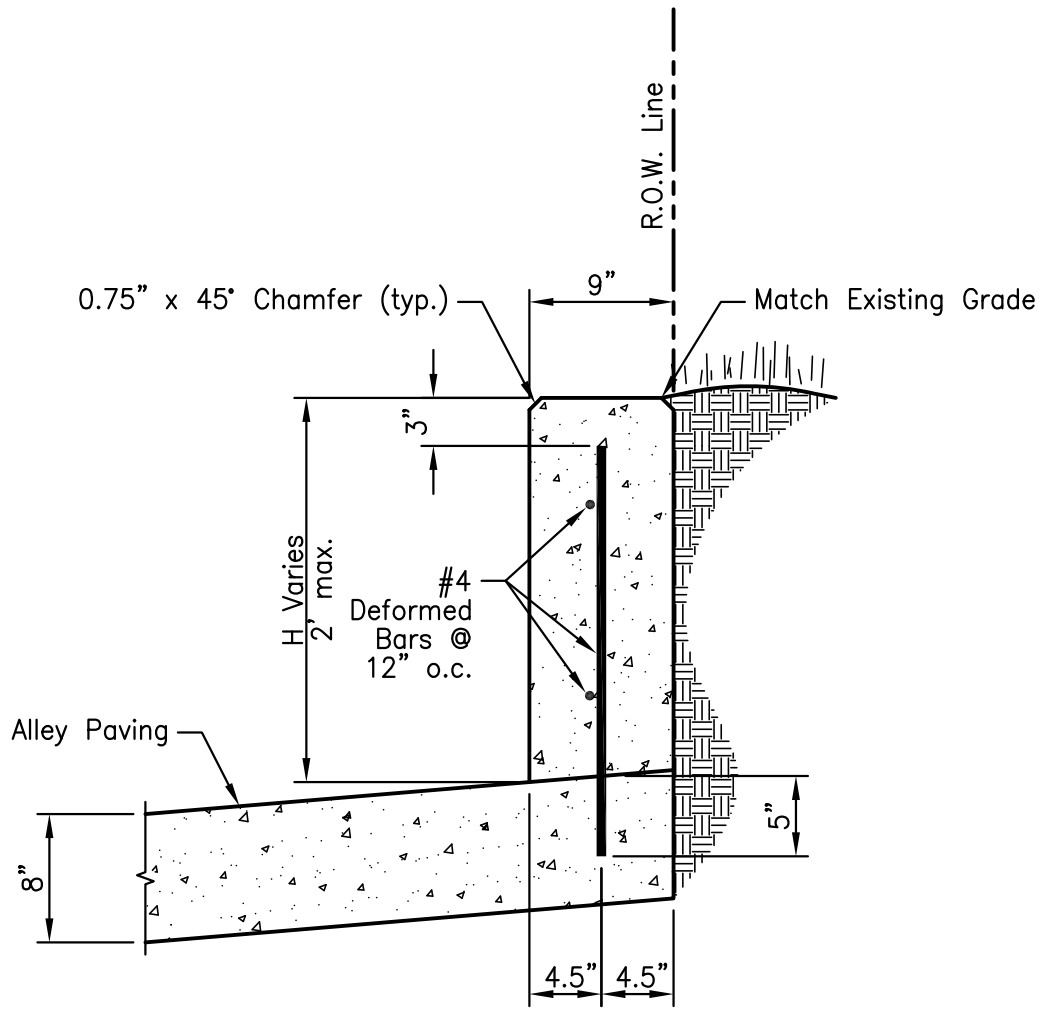

### ALLEY CURB HEAD

**Notes:**

1. Curb Head is to be poured separately from alley at locations as determined by PW.
2. Place No. 4 Deformed Bars at 12" on-center as directed by PW.
3. If the curb height is 6" or less no rebar is required.
4. For H greater than 2' a retaining wall design is required.
5. Jointing should be consistent with alley pavement joints.
6. This detail is for use by City projects when adjacent property grades cannot be reasonably transitioned to meet proposed alley grades. Any curb head taller than 2', shall be designed and planned outside the R.O.W.



City and County of Denver  
Transportation Standards & Details

Alley Curb Head

Date:  
04/17

Std. Dwg.  
10.4

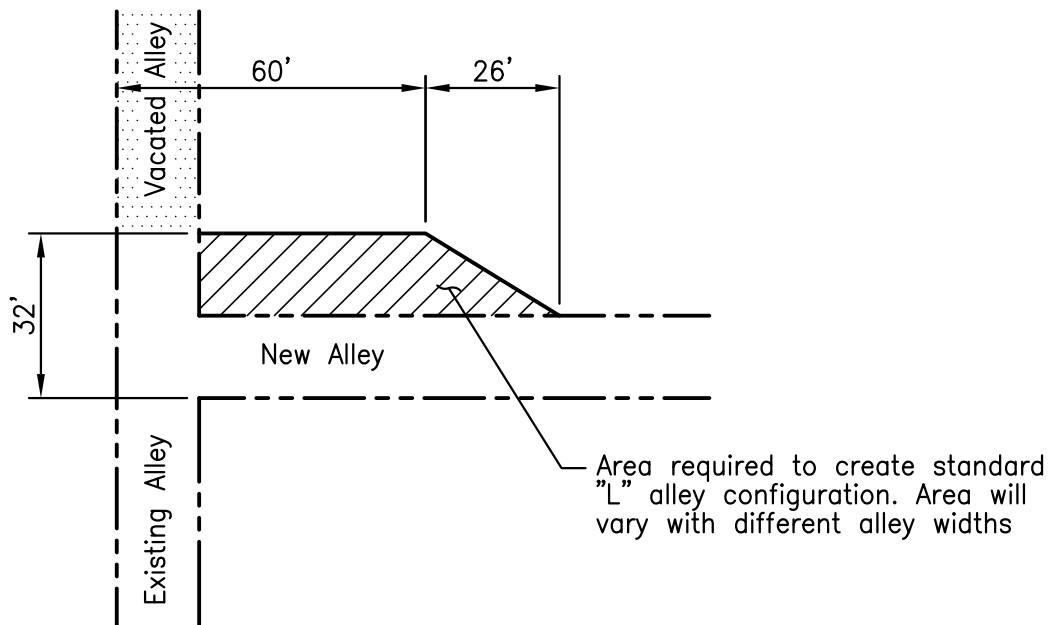
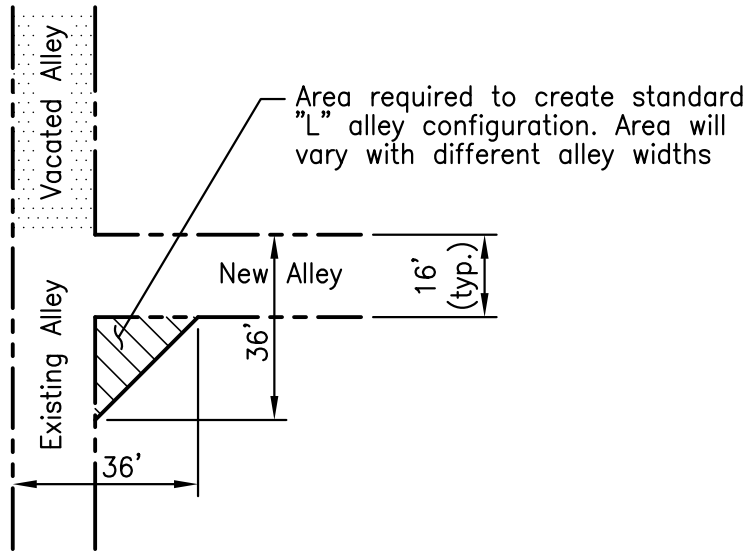

"L" TYPE ALLEY CONFIGURATIONS



City and County of Denver  
Transportation Standards & Details

Date:  
04/17

"L" Type Alley Configurations

Std. Dwg.  
10.5

## General Notes

- G-1) All concrete pavement and associated curb & gutter shall be placed on CDOT Class 6 aggregate base course, unless the existing subgrade materials are similar. Base shall be moisture conditioned, compacted, proof-rolled, final shaped, and re-compacted to allow the required thicknesses to be placed.
- G-2) Any concrete road that carries heavy traffic loads (1,000,000 ESALS or greater) shall apply (DC) Joints
- G-3) When within 100' of Railroad Track Centerline, concrete pavement for the entire roadway width shall be required for a minimum of 100' on either side of the Railroad Track centerline or 2' beyond Separator Medians, if any. Panels adjacent to tracks, bearing on ballast and/or aggregate base with separator geotextile, shall be reinforced with minimum 3 each full strength rebar (use tie bar size and spacing in table Std. Dwg. 11.0b) longitudinally, with one transverse bar at each end and middle, 2" clear, placed at depth T/2. Also use dowels per (DC) joints to adjacent panels.
- G-4) All Concrete placed in the public ROW shall be reinforced with fibers meeting ASTM C1116 and dosed at a minimum of 1.5 lbs. per cubic yard, or as otherwise specified.

## Design Layout

- DL-1) Transverse Joints are across traffic direction, Longitudinal Joints are with traffic direction. Traverse Contraction Joint spacing should not exceed 15 feet nor 150% of the Longitudinal Joint spacing.
- DL-2) Construction Joint locations are dependent on manhole locations, traffic control constraints, and contractor's placement sequence. All features must be shown on joint plans.
- DL-3) For new construction, all transverse joints ((A), (B), (C), (DA), and (DC)) shall be continuous across the pavement and curb and gutter. Construct transverse joints perpendicular to the centerline of pavement and extend the sawed joint through the curb and gutter. Gutter sections do not require dowels. Curb and gutter section should be designed to match the intended panel joint layout. New panels shall have no more than 2 sides with an (E) joint.
- DL-4) If the contractor proposes variations from this standard or the project has unusual or irregular conditions not discovered herein, a pavement joint layout shall be prepared for approval by Public Works.
- DL-5) Longitudinal joints shall coincide with edge of lane markings, if possible, and have a maximum spacing of 13' or 14' to back of curb if monolithic without extra joint. All longitudinal joints shall be tied. Lane widths over 13' require special design.
- DL-6) The contractor shall use a circular blockout at new manholes and other roadway appurtenances of similar or larger sizes. Small appurtenances, such as valves, monument boxes, and existing manholes do not require a blockout, but do require a bond breaker and flexible expansion joint material. Unless otherwise directed, the blockout may be eliminated at new manholes if Removable CLSM is used for backfill around the manhole collar from manhole base to paving subgrade where soil compaction equipment cannot reach.
- DL-7) Full panel replacement may be required at new curb cuts to concrete streets if the (Z) joints of the driveway surfaces do not line up with the (C) or (DC) joints of street pavement. Selected (L) joint tie bars may be eliminated between drive pan and pavement. Use (L) joints on longitudinal tie-ins along street direction.
- DL-8) Minimum width of concrete lane widening is 18" using (L) joint. Special jointing and reinforcing plans are required when transverse to longitudinal spacing is >1.33 or <0.75. Full panel length rebar is required when these panel size ratios are exceeded. Use minimum #4 epoxy coated rebar spaced per table on Std. Dwg. 11.0b for tie bars, 2" clear at ends, placed at depth T/2.

Continued on 11.0b...



City and County of Denver  
Transportation Standards & Details

General Notes for Concrete  
Pavement and Joints

Date:  
04/17

Std. Dwg.  
11.0a

...continued from 11.0a

## Reinforcing Size Table

Pavement Thickness T (in)	Tie Bar Size Grade 40 (deformed)	Dowel Bar Dia (in) Grade 60 (smooth)
T < 8	No. 4	1.00
8 ≤ T ≤ 10	No. 5	1.25
10 < T ≤ 15	No. 6	1.50

## Tie Bar and Dowel Bar Spacing

Joint Type	Tie Bars deformed, 30" long		Dowel Bars smooth, 18" long	
	on center	from edge	on center	from edge
DA	N/A	N/A	12"	12"
DC	N/A	N/A	12"	12"
E	30"	15"	N/A	N/A
L	30"	15"	N/A	N/A
X	12"	12"	N/A	N/A

### Reinforcing

- R-1) Tie bars shall conform to AASHTO M284 grade 40, epoxy coated, and deformed. Dowel bars shall conform to AASHTO M255 grade 60 for core material, and AASHTO M254 for epoxy coating the smooth bars. Dowel bars shall be wiped with form oil, but not dripping, just prior to concrete placement to prevent concrete bonding.
- R-2) Tie and dowel bars shall be normally started half the required spacing from a panel edge. Tie bars shall be kept at least 6" clear of any dowel bar. Tie bars may be slightly bent to follow this rule. Dowel bars shall be spaced the full width across intersections and merged traffic lanes. Straight traffic lane sections shall have a minimum of 4 dowels in each wheel path, and 5 in the wheel path adjacent to any shoulder or gutter.
- R-3) Dowel placement tolerances to be inspected and adjusted before concrete placement (refer to CDOT M-412-1 for graphical definition of terms and CDOT Specification 412.13(b)2) shall be:  
 a) Vertical Translation <1.0", Horizontal Translation <2.0" when spacing bars from edge panels.  
 b) Longitudinal (End) Shift (equal bar length in each panel) <2.1"  
 c) Horizontal and Vertical Rotational Alignment (ends not parallel with pavement surface) <0.5"

## Expansion Joint (A), (B), (DA) Maximum Spacing by Adjacent Concrete Temperature at Placement

Placing New Concrete Against Existing Concrete at This Temperature (°F)	The 2 Each at ¾" Expansion Joints at PCR is OK for this PCR to PCR Spacing of	OR	Add a Mid-block Joint with ½" Material for Maximum PCR to PCR Spacing of	Add a Mid-block Joint with ¾" Material for Maximum PCR to PCR Spacing of
40 to 59	425 feet		575 feet	650 feet
60 to 79	650 feet		875 feet	975 feet
80 and above	1300 feet		1750 feet	1950 feet

Continued on 11.0c...

	City and County of Denver Transportation Standards & Details	Date: 04/17
	General Notes for Concrete Pavement and Joints	Std. Dwg. 11.0b

...continued from 11.0b

### Expansion Joint

- EXP-1) When PCR to PCR distance is more than table (Dwg. 11.0b), then additional joints at mid-block are required for longer block intervals between intersecting streets. Expansion joints also required when concrete intersects concrete.
- EXP-2) Any sidewalk, concrete street or median including attached curb & gutter shall have expansion joints meeting this criteria, depending on ADJACENT existing concrete temperature at placement time.
- EXP-3) Any sidewalk, concrete street or median including attached curb & gutter TOUCHING AT ANY ANGLE to any concrete street, sidewalk, median, curb & gutter or valley gutter shall meet the same spacing criteria.
- EXP-4) When new work meets existing, and the existing is deficient in expansion joint width; the connection shall be an expansion joint with total width meeting this criteria.
- EXP-5) Medians and planter boxes shall honor the expansion and contraction movement of this joint.
- EXP-6) Use (CA) transition joint at concrete asphalt surface.

### Saw and Seal

- SS-1) All sawn joints shall be to a minimum depth of T/4 when no reinforcing steel is used, and not less than T/3 when tie bars or dowel bars are used. T is pavement thickness; T/4 is 25% of thickness, T/3 is 33% of thickness.
- SS-2) If a sawed appearance joint is desired inside regular panels, it shall be no more than 0.5" deep. This appearance joint is designated (SA).
- SS-3) Take reasonable measures during saw cutting and joint cleaning to prevent particulate matter from becoming airborne and to prevent the discharge of particulate matter beyond the property from which the emissions originate. The measures must be effective in the control of fugitive particulate emissions and runoffs at all times on the project site, including periods of inactivity.
- SS-4) Immediately after sawing, joints shall be cleaned by pressurized water jet or other approved method. Joints shall also be cleaned and dried with sandblasting and compressed air just ahead (100' or less) of placing backer rod material and joint sealant. Joint cleaning methods shall be contained or vacuumed to prevent fugitive dust and runoff. Public Works may require other methods of joint cleaning if necessary.

### Patching

- P-1) Notes for Panel Replacements or rework for Trench Patches when ideal situations do not apply:
  - a) Full panel replacement to normal joint lines is required.
  - b) For establishing transverse joints, maintain the existing joint gap on existing adjoining panels at the time of panel replacement. Remove any gap filling material in the new joint before new joints are sealed. Use expansion caps or deeper hole, the same as the gap width on the poured end of dowels to allow future movement of the entire length of joint across all lanes.
  - d) Consult PW ROW Inspector Dept. for advice on special situations. Use of bond breakers, eliminating selected tie bars for offset joints or narrow panels, use of predicted crack mitigation techniques, added panel replacements, or special reinforcing for narrow or skinny panels may be advised or required.
  - e) The Contractor's warranty obligation shall not be waived if CCD conveys any advice or directive for non-standard situations.

	City and County of Denver Transportation Standards & Details	Date: 04/17
	General Notes for Concrete Pavement and Joints	Std. Dwg. 11.0c

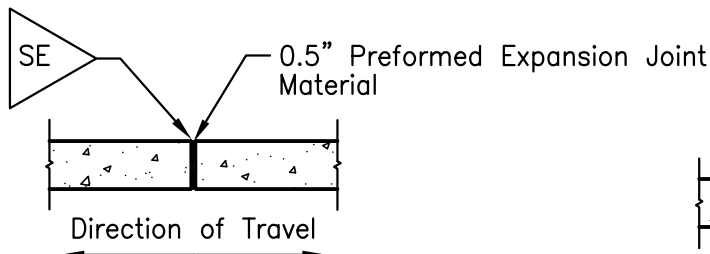

**(H) NON-ROADWAY EXPANSION JOINT**

All concrete panels with an adjacent (H) joint shall be generally square and shall not exceed 1.5L:1W shape. Triangular panels should not have any angles less than 30 degrees.

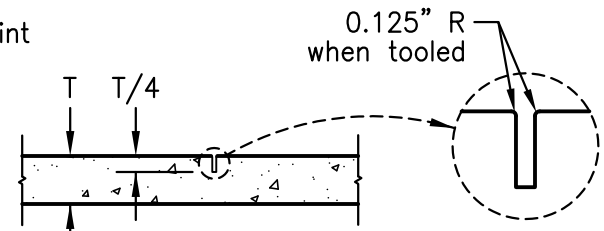

**(Z) NON-ROADWAY CONCRETE TOOLED OR SAWED JOINT**

Note that (Z) Joints in multi-use paths must be sawed. Sidewalk joints may be either tooled or sawed.

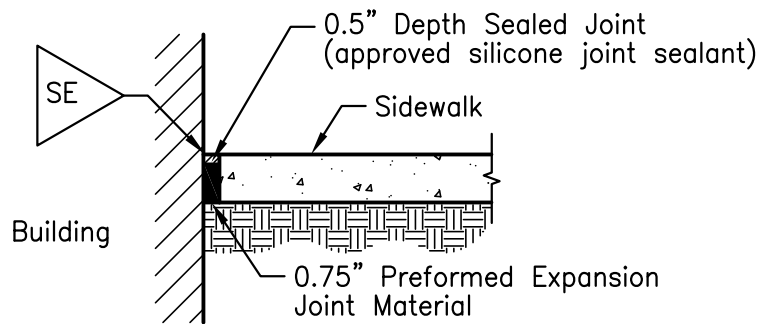

**EXPANSION JOINT BETWEEN SIDEWALK AND BUILDINGS**

**Notes:**

1. Joint spacing for concrete curb & gutter and sidewalk:
  - 10' - Combination curb, gutter, and sidewalk
  - 10' - Curb & gutter, curb head, or mountable curb
  - 5' - Detached and attached sidewalks
2. For sidewalks, expansion joints shall be provided every 100' to 120' and shall extend the full depth of the concrete walk. May be lengthened for curve walks with approval of Public Works.
3. (H) joints shall be installed between new sidewalk and existing concrete slabs, inlets, fire hydrants, poles, and other fixed objects.
4. Expansion joint material between curb and sidewalk is required when sidewalk abuts back of curb on concrete streets.
5. These details and notes do not apply to bike paths - See Parks & Recreation Standards.
6. Minimum widening of sidewalks shall be 18". Apply (L) joint between existing and proposed sidewalk concrete.



City and County of Denver  
Transportation Standards & Details

Concrete Non-Roadway Joints  
H & Z

Date:  
04/17

Std. Dwg.  
11.1

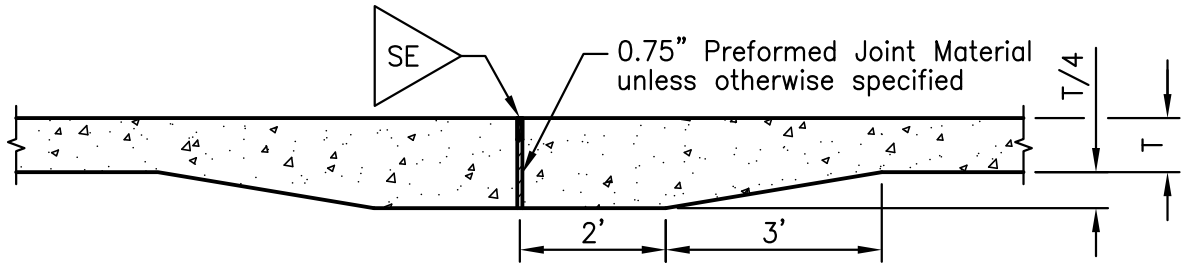

**(A) CONCRETE ROADWAY EXPANSION JOINT (WITH THICKENED EDGE)**

For pavements requiring smooth dowel bars in transverse joints  
 (Any (A) Joint may be replaced with a (DA) Joint; Apply (CA) whenever adjacent pavement is asphalt)

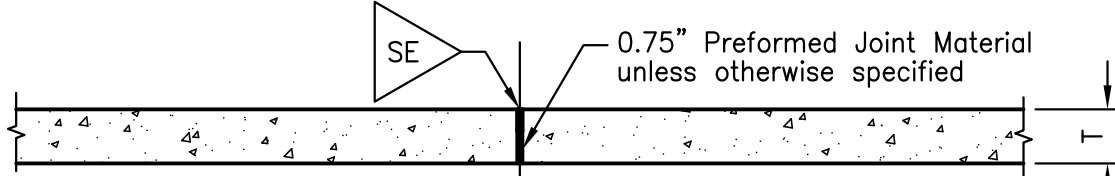

**(B) CONCRETE ROADWAY EXPANSION JOINT (WITHOUT THICKENED EDGE)**

For lower traffic situations or when new concrete is abutting existing concrete

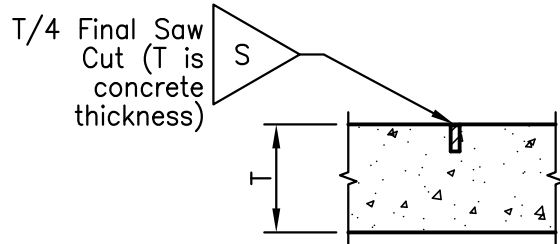

**(C) CONCRETE ROADWAY SAWED TRANSVERSE CONTRACTION JOINT**

For use in applications where ESALS are less than 1,000,000

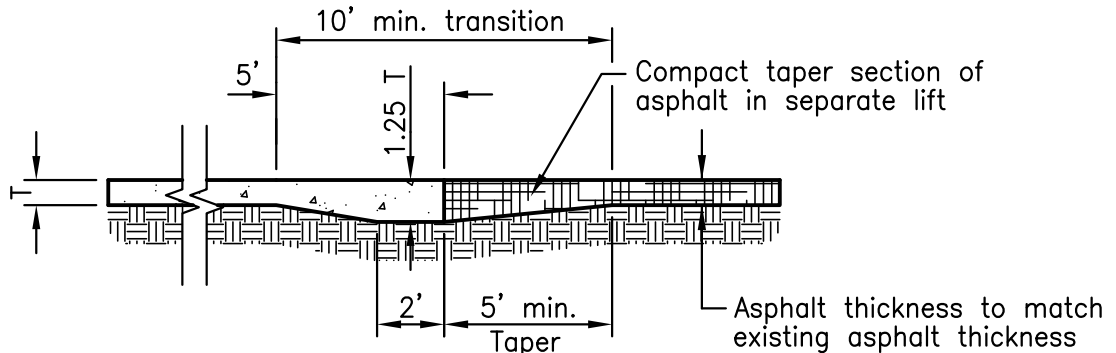

**(CA) CONCRETE ROADWAY TO ASPHALT PAVEMENT TRANSITION**

Epoxy coated smooth dowel, 12" spacing, 12" from edge, using dowel basket per (DC) joint, or drilled into one side of existing.

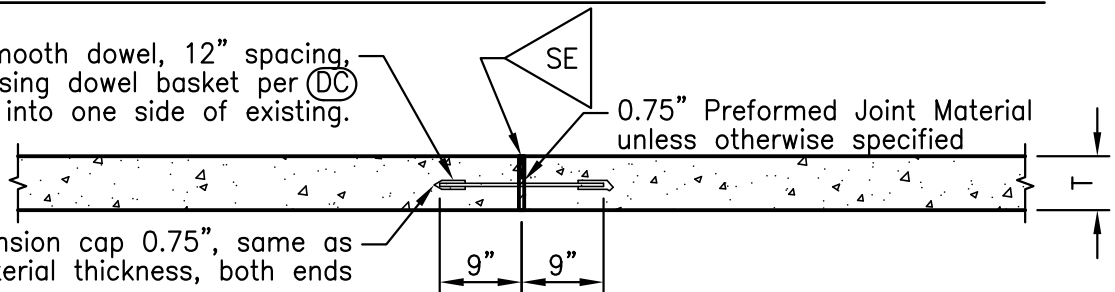

Provide expansion cap 0.75", same as expansion joint material thickness, both ends

**(DA) CONCRETE ROADWAY DOWELED EXPANSION JOINT**



City and County of Denver  
 Transportation Standards & Details

Concrete Roadway Joints and  
 Transitions A-DA

Date:  
 04/17

Std. Dwg.  
 11.2

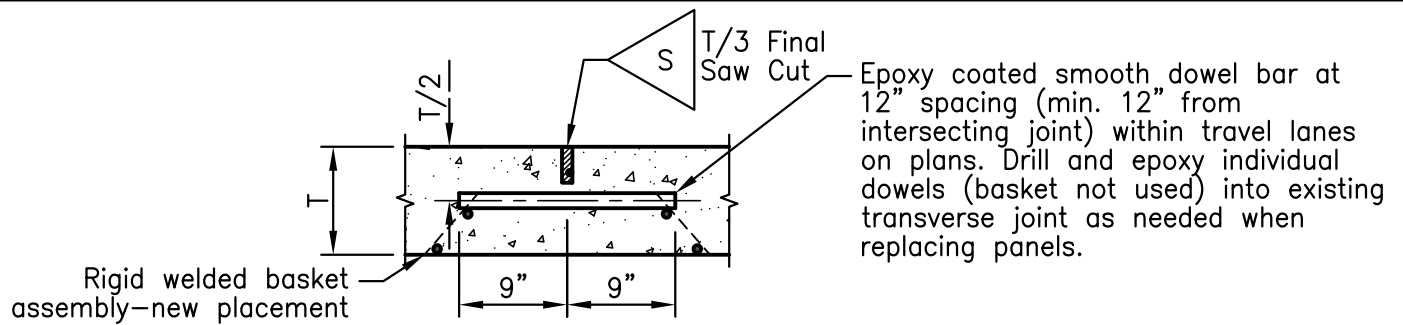

**(DC) CONCRETE ROADWAY DOWELED TRANSVERSE CONTRACTION JOINT**

For use in applications where ESALS equal to or greater than 1,000,000.

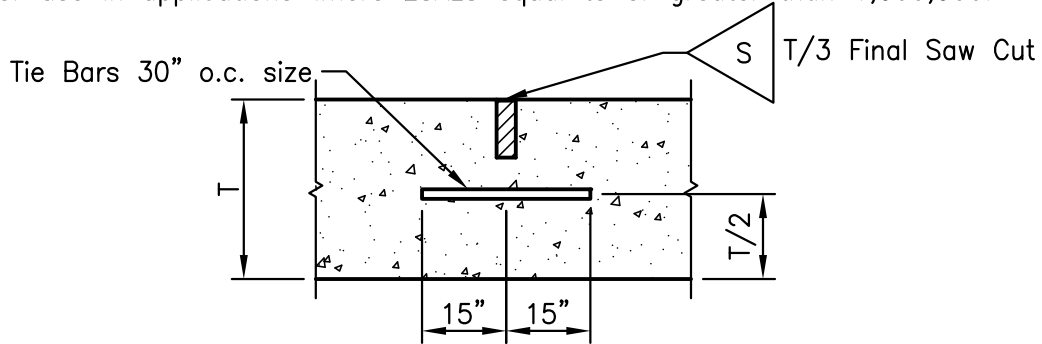

**(E) CONCRETE ROADWAY LONGITUDINAL CONTRACTION JOINT**

(Any (E) Joint may be replaced with an (L) Joint)

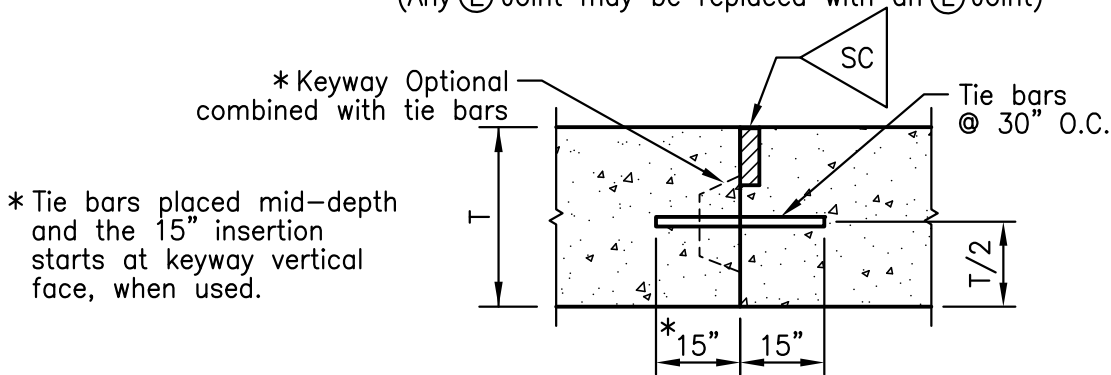

**(L) CONCRETE ROADWAY LONGITUDINAL CONSTRUCTION JOINT**

Equivalent to CDOT's L joint; Not for use when adjacent pavement is asphalt

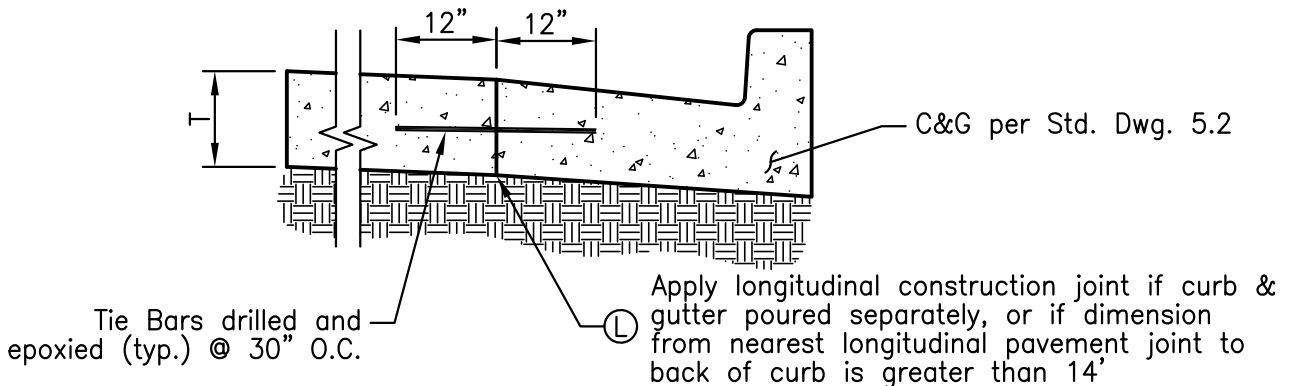

**(L) (at C&G) CONCRETE ROADWAY TO CURB AND GUTTER JOINT**



City and County of Denver  
Transportation Standards & Details

Date:  
04/17

Concrete Roadway Joints and  
Transitions DC-L

Std. Dwg.  
11.3



0.5" or less than T/16

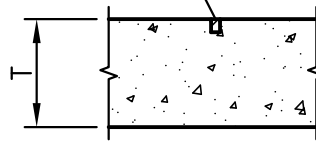

**(SA) CONCRETE ROADWAY SAWED APPEARANCE JOINT**

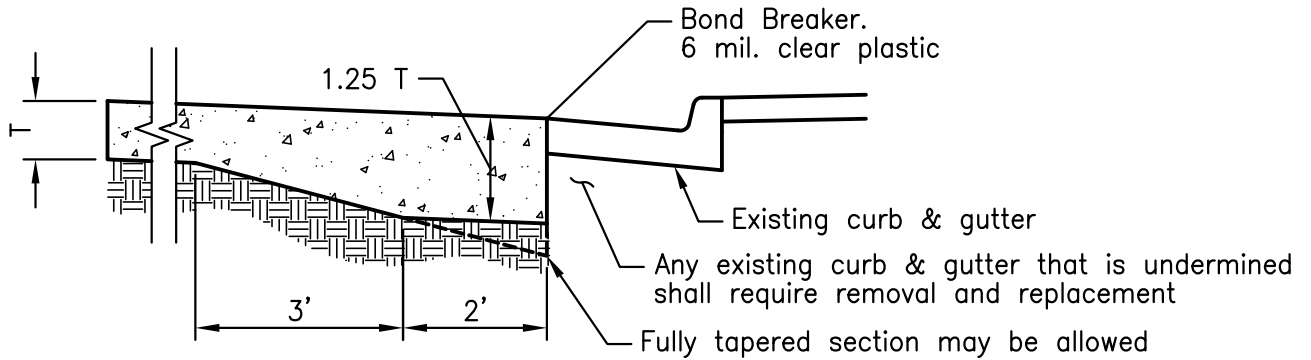

**(TE) CONCRETE ROADWAY TO EXISTING CURB AND GUTTER TRANSITION**

No tie-bars required for short sections. Extra precautions are needed to obtain suitable compaction due to hand work

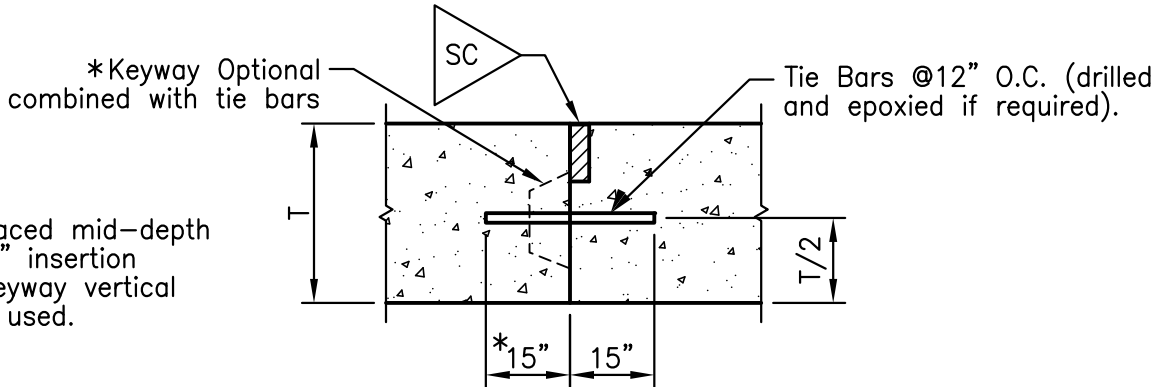

\*Tie bars placed mid-depth and the 15" insertion starts at keyway vertical face, when used.

**(X) CONCRETE ROADWAY MID PANEL TRANSVERSE CONSTRUCTION JOINT**

More steel than CDOT's T joint

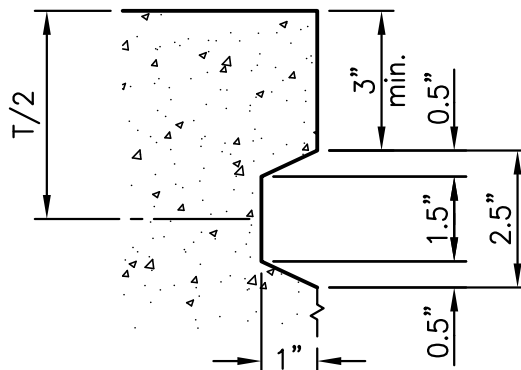

**OPTIONAL ADDED KEYWAY DETAIL TO (X) OR (L)**

Only when T ≥ 9". Form only female keyway



City and County of Denver  
Transportation Standards & Details

Concrete Roadway Joints and  
Transitions SA-X

Date:  
04/17

Std. Dwg.  
11.4

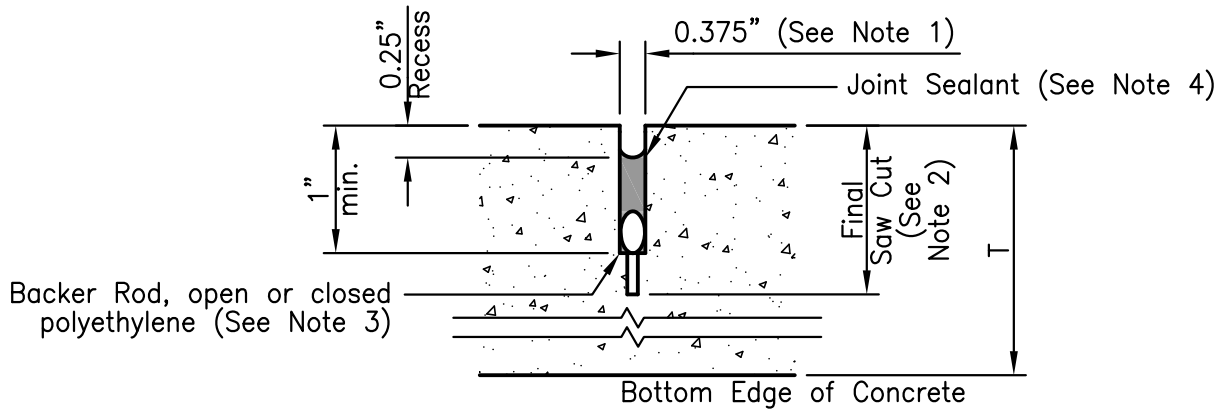

**S SEAL AT SAWED JOINT**

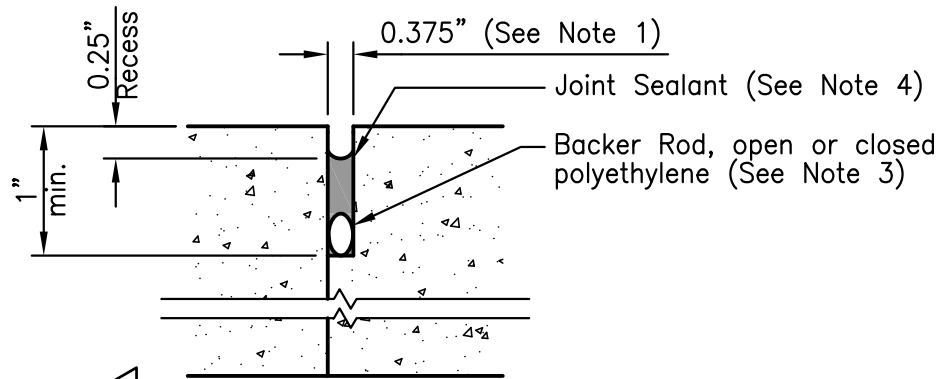

**SC SEAL AT CONSTRUCTION JOINT**

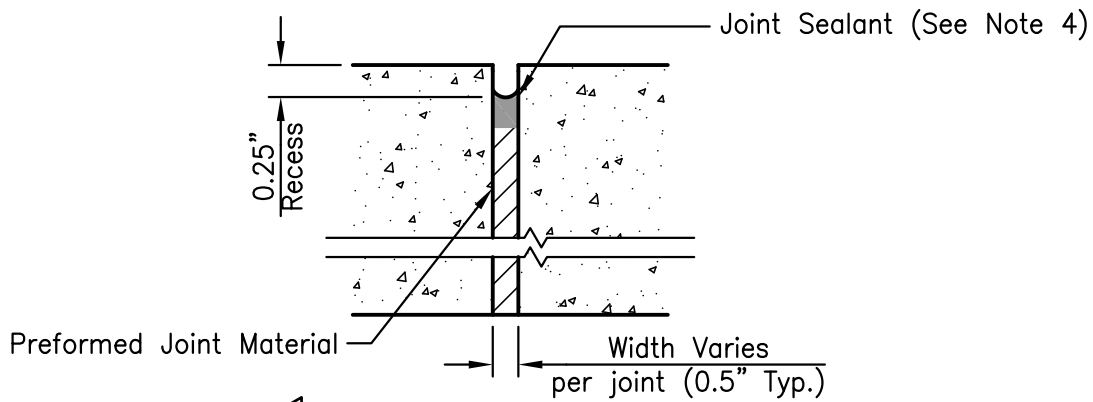

**SE SEAL AT EXPANSION JOINT**

**Notes:**

1. Saw and seal width may be 0.1875" (3/16") maximum for new paving areas. Width may be 0.375" (3/8") maximum when matching existing appearance.
2. The final saw cut depth when no steel is present is T/4. The final saw cut depth when steel is present (tie or dowel bars) is T/3. T is the concrete thickness.
3. Uninstalled backer rod diameter shall be twice the saw and seal width.
4. Joint sealant thickness should be equal to saw width. Joint sealant shall be approved silicone sealant, rated for streets or highways.



City and County of Denver  
Transportation Standards & Details

Concrete Joint Sealants

Date:  
04/17

Std. Dwg.  
11.5

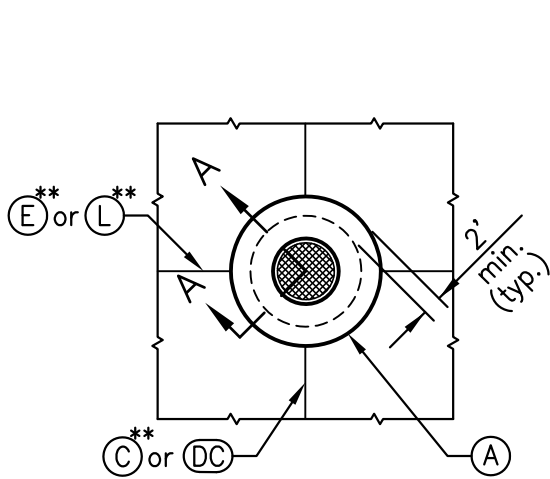

CIRCULAR BLOCKOUT AT  
NEW MANHOLE\*

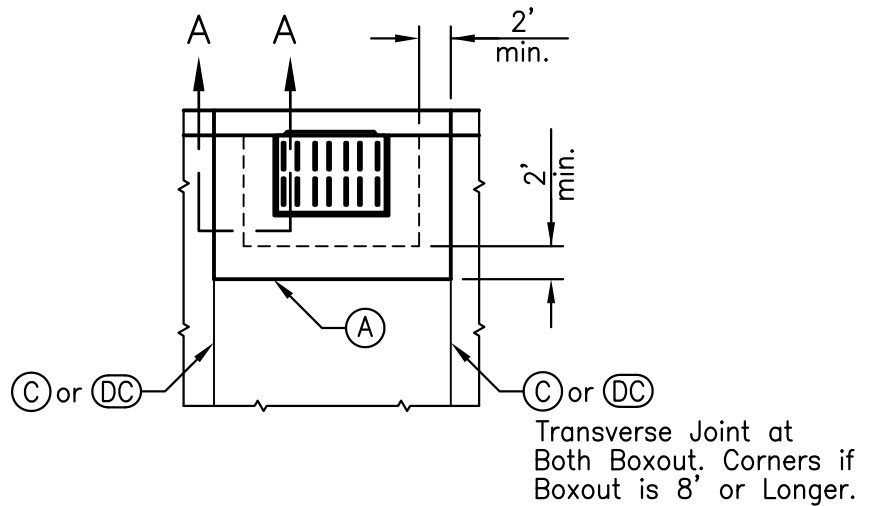

BOXOUT AT INLET

\* Unless otherwise directed, the boxout may be eliminated if Removable CLSM is used for the entire backfill around the manhole collar.

\*\* Joints must line up with other Joints and not dead-end or tee at panel sides. Transverse joint spacing shall be adjusted to align at the diameter, or pass at least 4' from the blockout. Use skewed longitudinal joints when the joints are within 2' of the blockout.

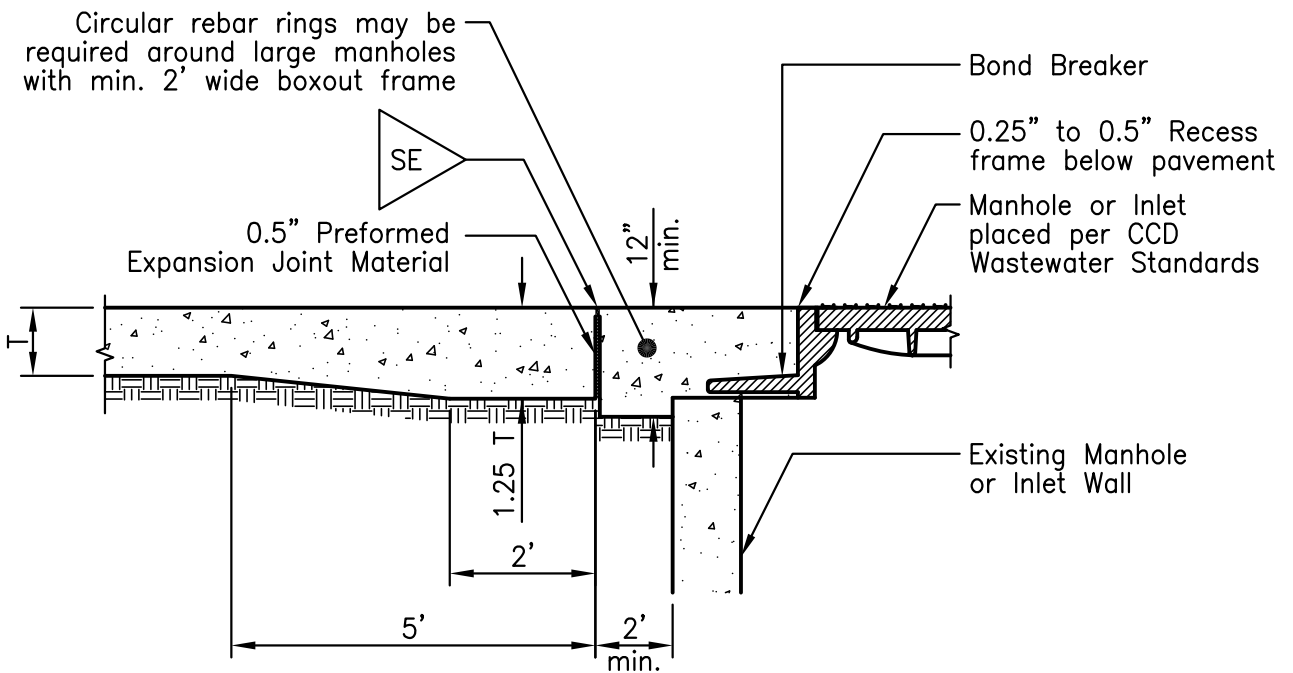

SECTION A-A BLOCKOUT/BOXOUT



City and County of Denver  
Transportation Standards & Details

Concrete Roadway Jointing at New  
Manholes and All Inlets

Date:  
04/17

Std. Dwg.  
11.6

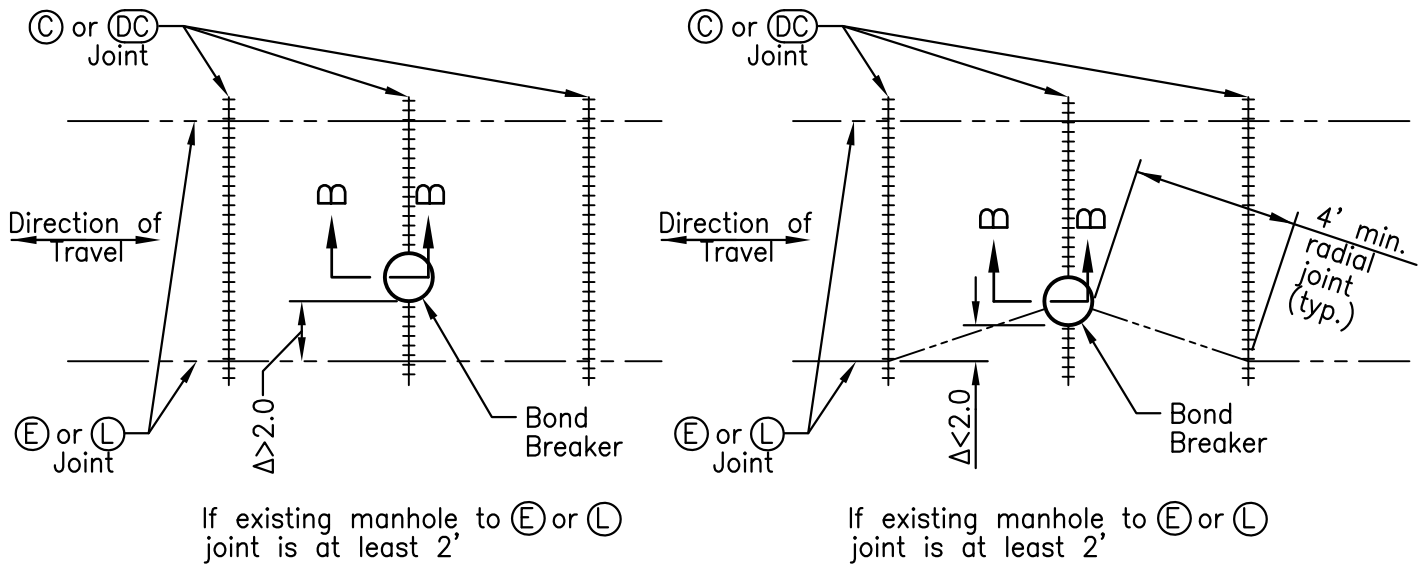

Note: Adjust © or (DC) to hit on diameter of manhole or pass at least 4' from the blockout.

### EXISTING MANHOLE

When distance to nearest longitudinal joint is greater than or equal to 2'

### EXISTING MANHOLE

When distance to nearest longitudinal joint is less than 2'

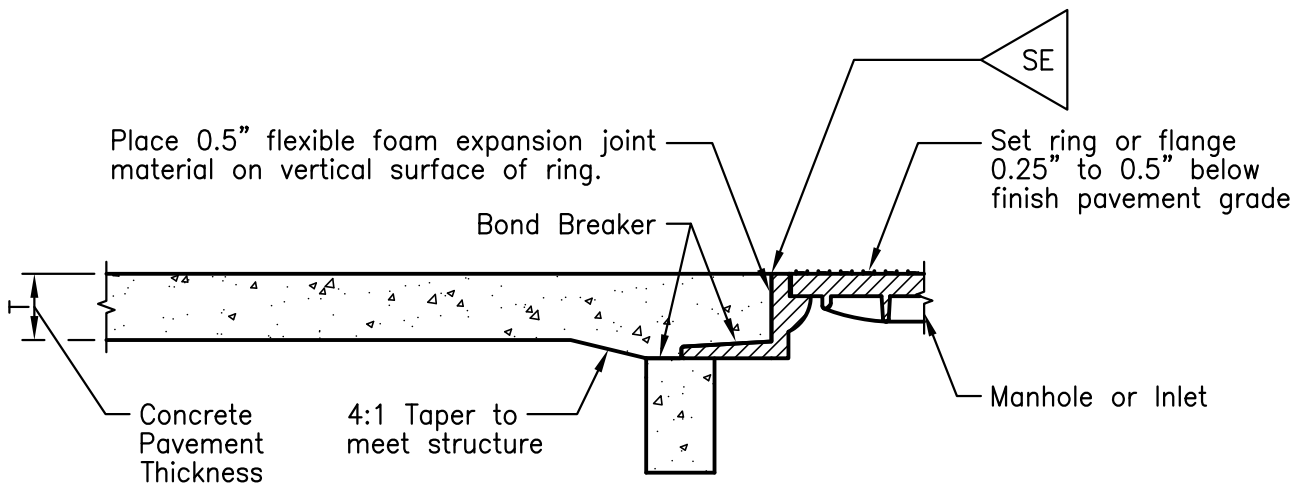

### SECTION B-B

Notes:

1. Bond Breaker shall be composed of plastic sheet, building paper, or other approved material to prevent bonding.
2. The sides of all valve boxes, pipes, manhole ring or flange, and objects penetrating a placement shall be wrapped full depth with sealant backer material (Type 2 compressible foam sheets) meeting ASTM D 5249.



City and County of Denver  
Transportation Standards & Details

Concrete Roadway Jointing at  
Existing Manholes

Date:  
04/17

Std. Dwg.  
11.7

Joint not required if curb & gutter poured monolithically with adjacent lane, and lane width to back of curb width does not exceed 14'

Circular Blockout at new Manhole

\*Place  $\frac{3}{4}$ " min. expansion joint filler in full section of pavement and curb & gutter, including the top 6" of curb joint at intersection return radius points. May require extra cut in curb head when not at expansion joint

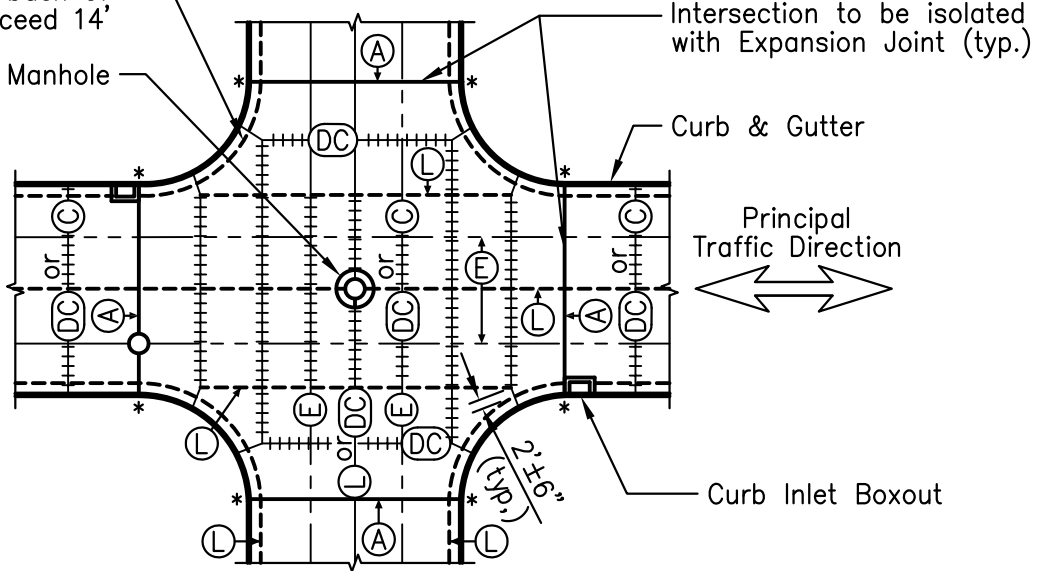

Plan Joints to properly connect to proposed corner curb ramps

8" thick or less  
8' min. 12' max.

or

Thicker than 8"  
8' (min.) 15' (max.)

6' min.

Permissible alternate joints with small radii < 16'

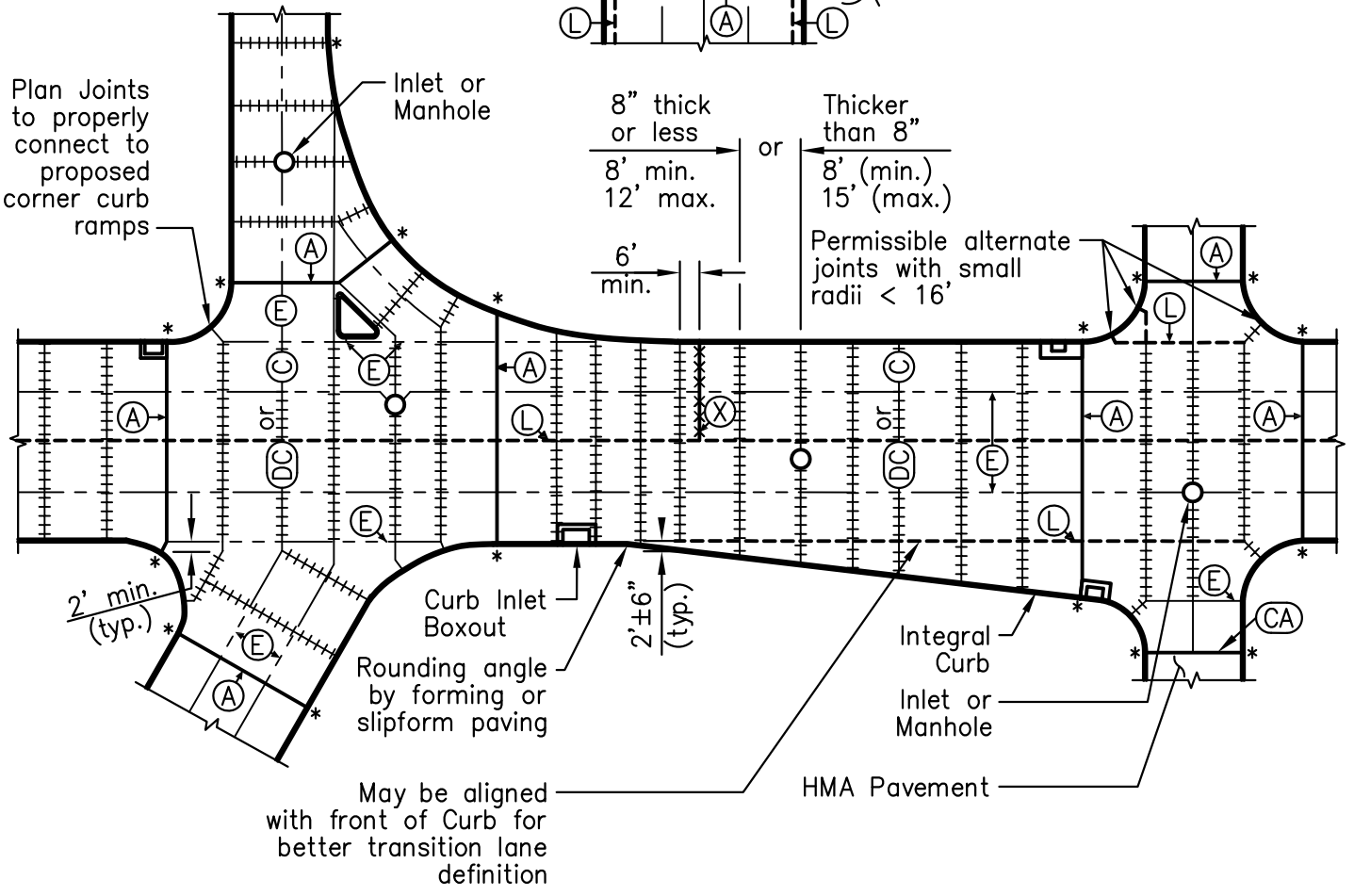

May be aligned with front of Curb for better transition lane definition



City and County of Denver  
Transportation Standards & Details  
Concrete Roadway Typical Joint  
Layout

Date:  
04/17  
Std. Dwg.  
11.8

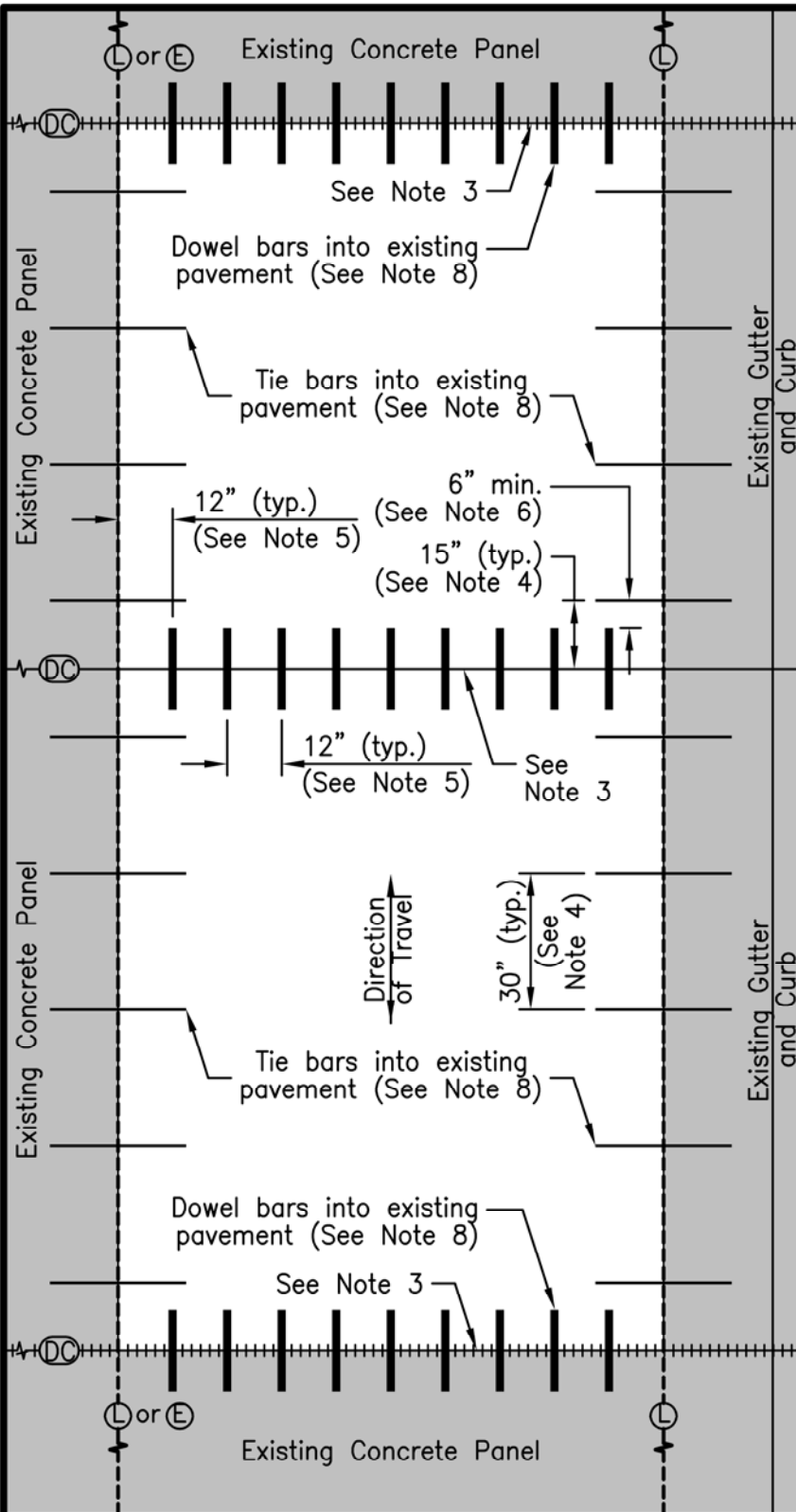

Notes:

1. All saw cuts shall be straight and follow existing panel joint lines. Contractor should use full slot cut to relieve pressure and minimize damage to surrounding panels during panel removals. Contractor shall replace any panels damaged during their activities. Consult City Inspector for alternate instruction when existing joints do not line up.
2. Subgrade preparation shall be completed to meet compaction and proofroll specifications. The surface shall be smooth and flat including areas under tie and dowel bars. Add 4" Class 6 Aggregate Base Course meeting moisture and compaction specifications if subgrade is not sand or gravel.
3. Re-establish any existing expansion joints (A or DA) in transverse joints with full-depth expansion joint material. Match existing saw cut width of surrounding panels.
4. All steel is placed at mid-depth of thickness (T/2).
5. Use (DC) joints even if dowels did not previously exist in transverse joints.
6. Minimum clearance between tie bars and dowel bars is 6". Tie bars may be bent horizontally to achieve clearance.
7. Tie bar spacing may be adjusted to keep 15" clear from any non-ideal panel lines and gutter pan lines. Do not drill in tie bars if panel is <30" long or near any existing cracks.
8. Drill larger than dowel or tie bar and epoxy bars into existing concrete per supplier instructions. Eliminate tie bars in the shortest section of adjoining panels when joint lines do not align.
9. Exposed end of dowel bars shall be lightly oiled or greased. Tie bars used and exposed shall be clean, rust free, and not oiled or greased.
10. Repeat layout on the left for multiple lane replacement.



City and County of Denver  
Transportation Standards & Details

Concrete Roadway Panel  
Replacement

Date:  
04/17

Std. Dwg.  
11.9

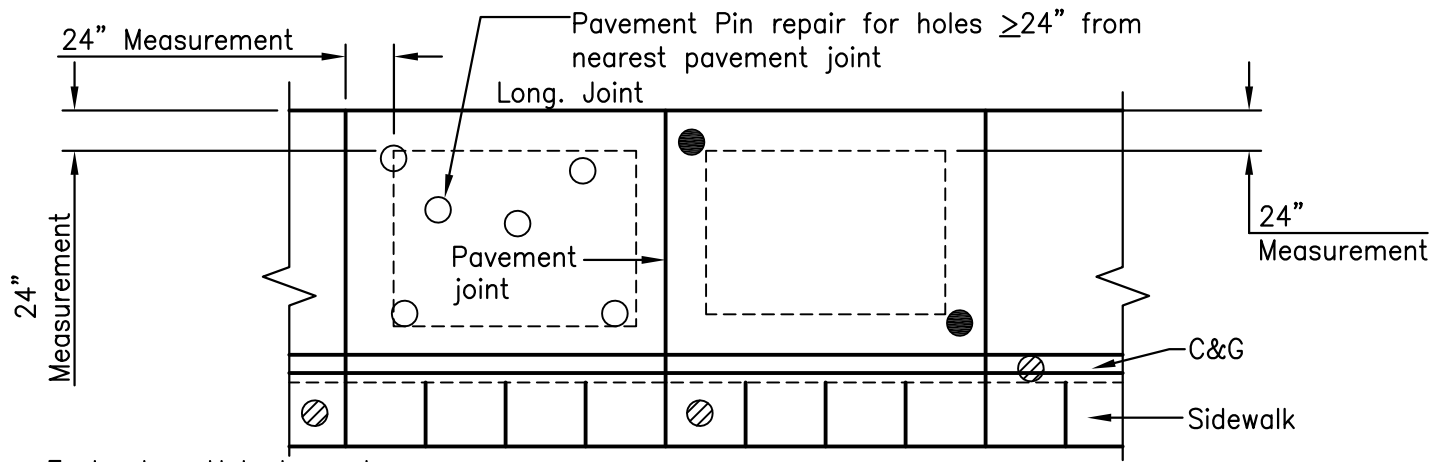

Exploratory Hole Legend

- Exploratory holes located 24" or greater from nearest concrete pavement joint. Perform Pin Repair per detail below. Up to 6 holes of this type allowed before full panel replacement is required. Existing holes are counted as part of total.
- Exploratory holes located less than 24" from nearest concrete pavement joint. Backfill of this type of hole shall be CLSM topped with non-shrink grout in pavement section. Do not use pin repair. Up to 2 holes of this type allowed before full panel replacement is required. Total count of existing plus current holes will be used.
- ⊗ Any exploratory hole placed in concrete surfaces outside of street paving requires full concrete panel replacement to nearest joint(s). No patching or partial panel removal/replacement allowed.

Pin Repair Detail

Perform when exploratory hole is 24" or greater from concrete pavement joint line

Install 3 tie bar pins (6" long #4 epoxy coated deformed tie bars) spaced apart at  $\frac{1}{3}$  or  $\frac{1}{4}$  of circle. Drill  $\frac{5}{8}$ " diameter holes 3" deep. Select widest dimensions for drilling. Start drill about 1" above pavement thickness ( $\frac{T}{2}$ ). Drill 3" into sides at 2:1 to 3:1 (H:V) angle

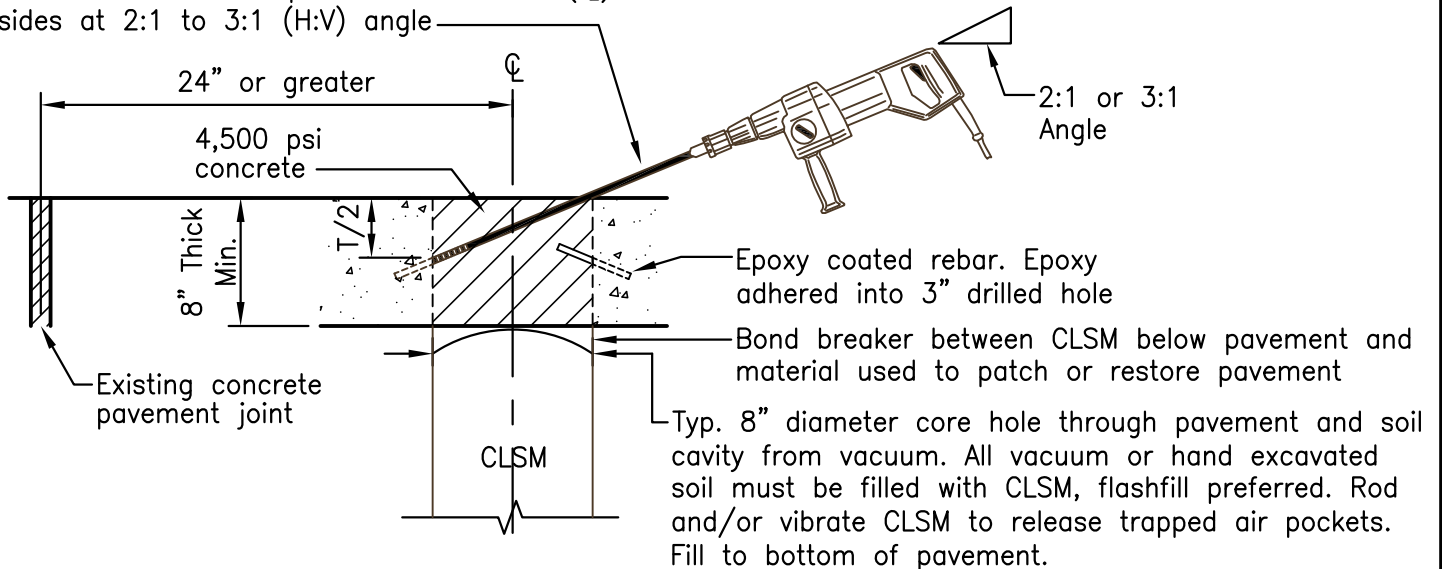

City and County of Denver  
 Transportation Standards & Details  
 Concrete Street Exploratory Holes  
 (Potholes) Typical Repair

Date:  
 04/17  
 Std. Dwg.  
 11.10

Patch width should be minimum of 2' or extend at least 1' beyond any damaged pavement as determined by PW inspector

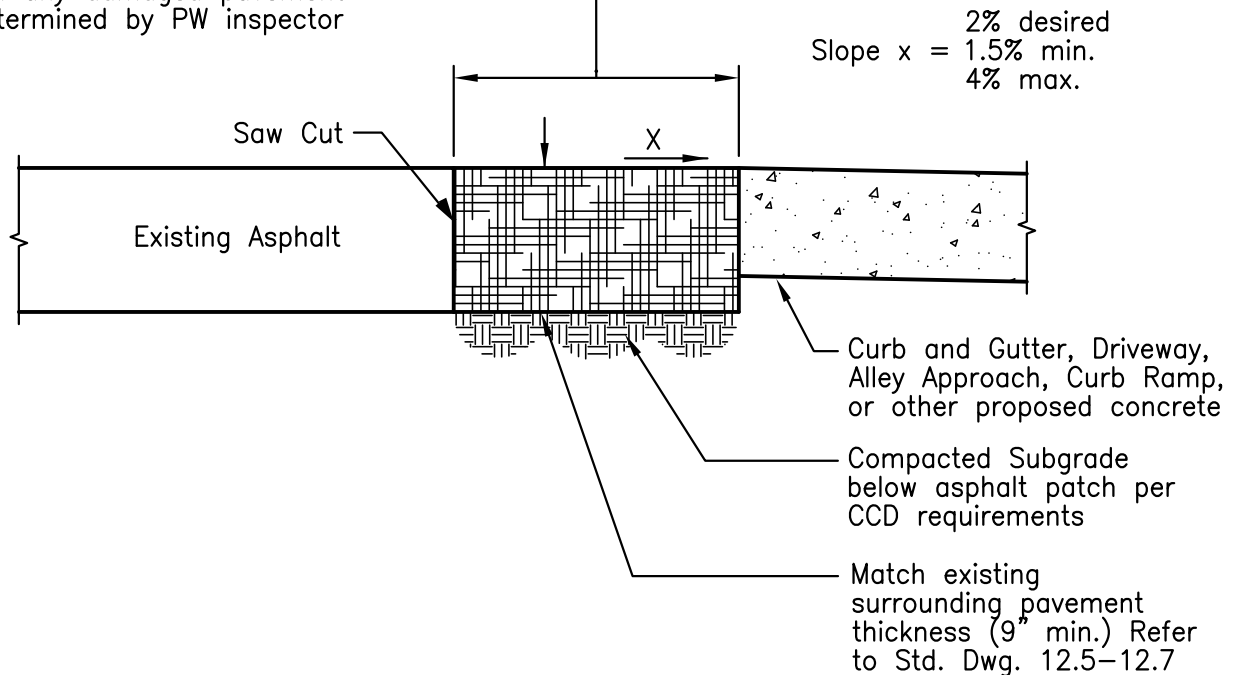

## ASPHALT PATCH

**Notes:**

1. Larger patch section is required on new streets or streets that have undergone recent pavement work.
2. Any patch performed on a Moratorium Street (streets constructed or having been re-surfaced within past (36 months) is subjected to special requirements:
  - a.) Patches into Moratorium or Residential Streets of LESS than 32 square feet, shall be patched using the method of infra-red heating into surrounding asphalt, adding rejuvenator liquid, mixing it with new and old asphalt, and re-compaction.
  - b.) Patches into Moratorium Streets of GREATER than 32 square feet, shall be patched using the "T" patch method. Refer to Std. Dwg. 12.2.
  - c.) When any single project or contractor makes 5 or more patches within any Moratorium Street, then the street shall be milled and overlaid at minimum of full lane (stripe to stripe or centerline/crown to curb and gutter) width, or more to cover all previous cuts. Mill and overlay shall start and stop at least 10 feet outside of the total of all cuts. All such paving shall be minimum 10 feet wide with self propelled paver with grade controls.
3. Any asphalt patch more than 10' wide, or more than one lane wide, may trigger reconstruction of more of the existing street. When required, street reconstruction shall be per Std. Dwg. 12.5-12.7
4. Avoid saw cuts in the existing or future planned wheel paths.
5. Lane edges (joints between paving passes) shall follow the traffic striped lanes as much as practicable. Lane edge joints shall not be in a wheel path. They should stagger previous edge by a minimum of 6" to avoid stacked edges.
6. Where existing cross-slope is steeper than 4%, patch cross-slope may be allowed to match, with approval of PW.



City and County of Denver  
Transportation Standards & Details

Asphalt Patch

Date:  
04/17

Std. Dwg.  
12.0



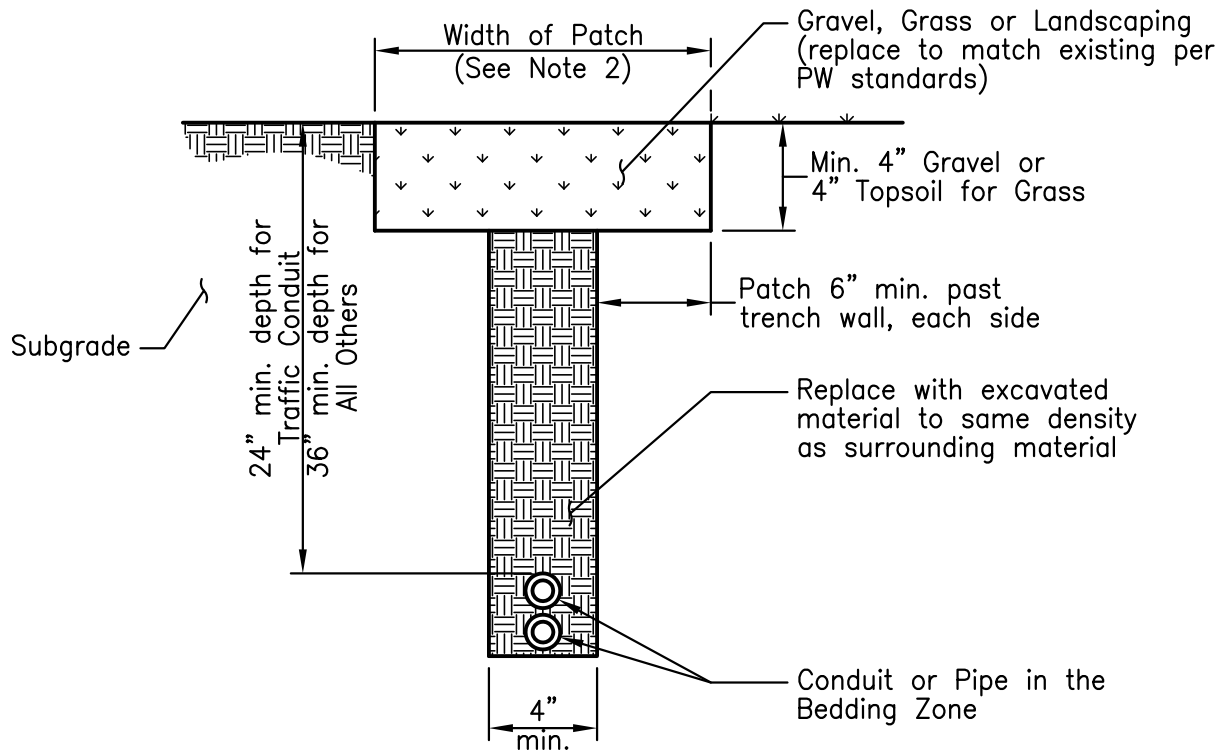

## TRENCH PATCH THROUGH EXISTING GRAVEL OR LANDSCAPING

### Notes:

1. Wherever possible, conduit or cable shall be installed by boring, driving, or any other acceptable means under concrete units. Open cutting shall be used only under special circumstances and only with approval of PW.
2. Minimum width and type of restoration to be determined by PW Inspector, based on contractor's pre-activity photos, to match pre-existing conditions.
3. Sod replacement shall be a minimum of 18" in width.
4. Any hardscape (concrete or pavers) should be replaced in full panels or pavers of the same type, color, and size as before.
5. Restoration in Denver Parks shall be per the Parks Operations Supervisor. Contact Denver Parks at (720)865-0368 for details and any permits required.
6. Any trenching within the drip line of existing R.O.W. trees must be approved by the Office of City Forester prior to commencement of construction activities. When necessary, utility installation under the canopy of existing trees must be directionally bored.



City and County of Denver  
Transportation Standards & Details

Trench Patch Through Existing  
Gravel or Landscape Materials

Date:  
04/17

Std. Dwg.  
12.1

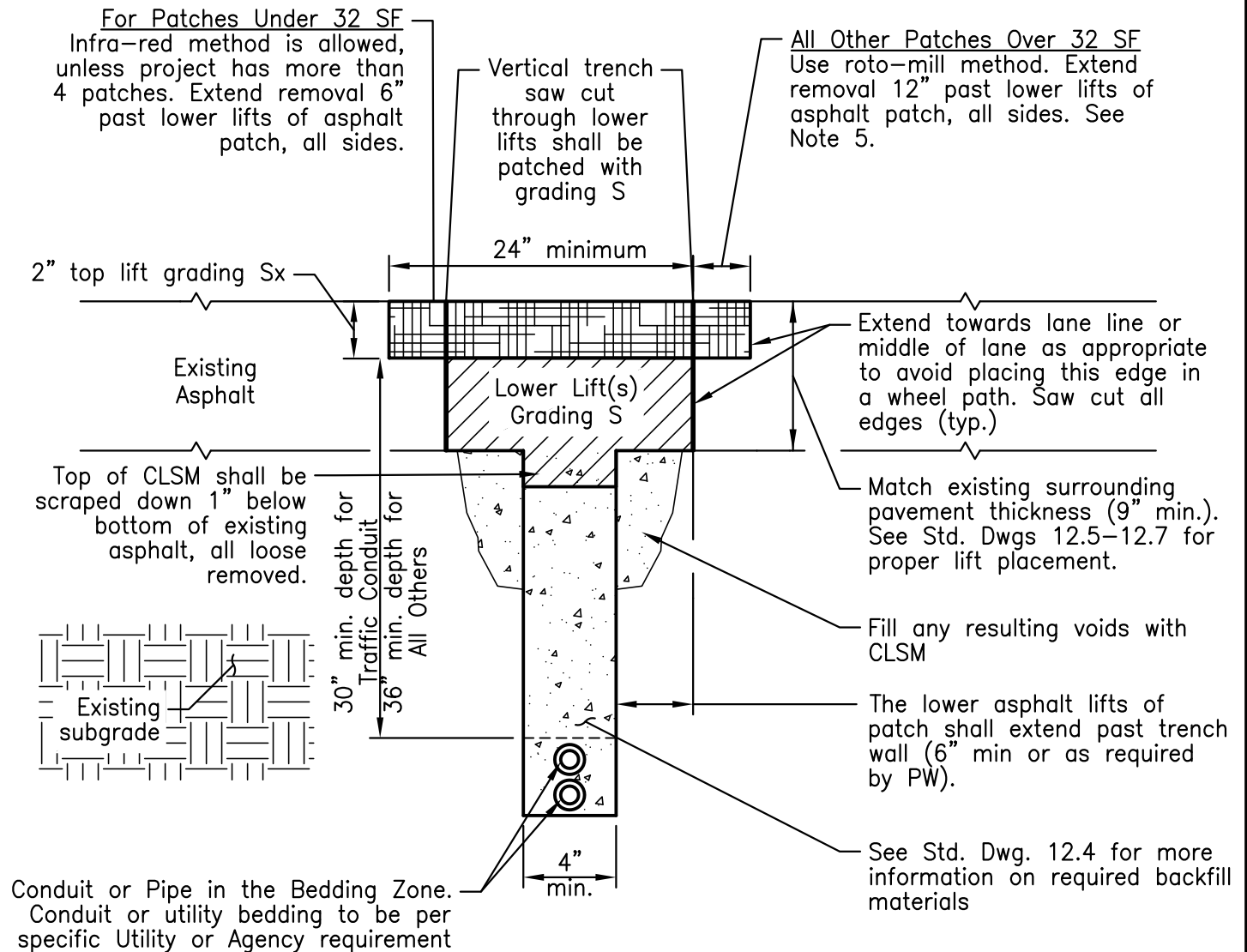

### TRENCH PATCH (ASPHALT)

Utility Excavation or Bore Access Hole

Notes:

1. This detail shall be applied for any patch or trench within a Moratorium asphalt street (resurfaced within the past 36 months).
2. Wherever possible, conduit or cable shall be installed by boring, driving, or any other acceptable means under concrete units. Open cutting shall be used only under special circumstances and only with approval of PW.
3. Removable CLSM layer thickness of Flow-Fill not to exceed 3' at a time, and bleed water shall be pushed off surface before another layer can be added. Flash-Fill may be placed full height thickness at one time.
4. Pipe or conduit shall be protected from floating when using CLSM. Use plastic wrapping to avoid Flash Fill from adhering to other conduits or pipes.
5. Streets in which any single project results in 5 or more total patches per street will be required to mill and overlay entire patched area of the street using lane lines as a point of overlay edge.
6. Apply tack coat to all exposed walls of existing asphalt that will not receive patching by infra-red.



City and County of Denver  
Transportation Standards & Details

Trench Vertical Patch (Asphalt) in  
Moratorium Street

Date:  
04/17

Std. Dwg.  
12.2

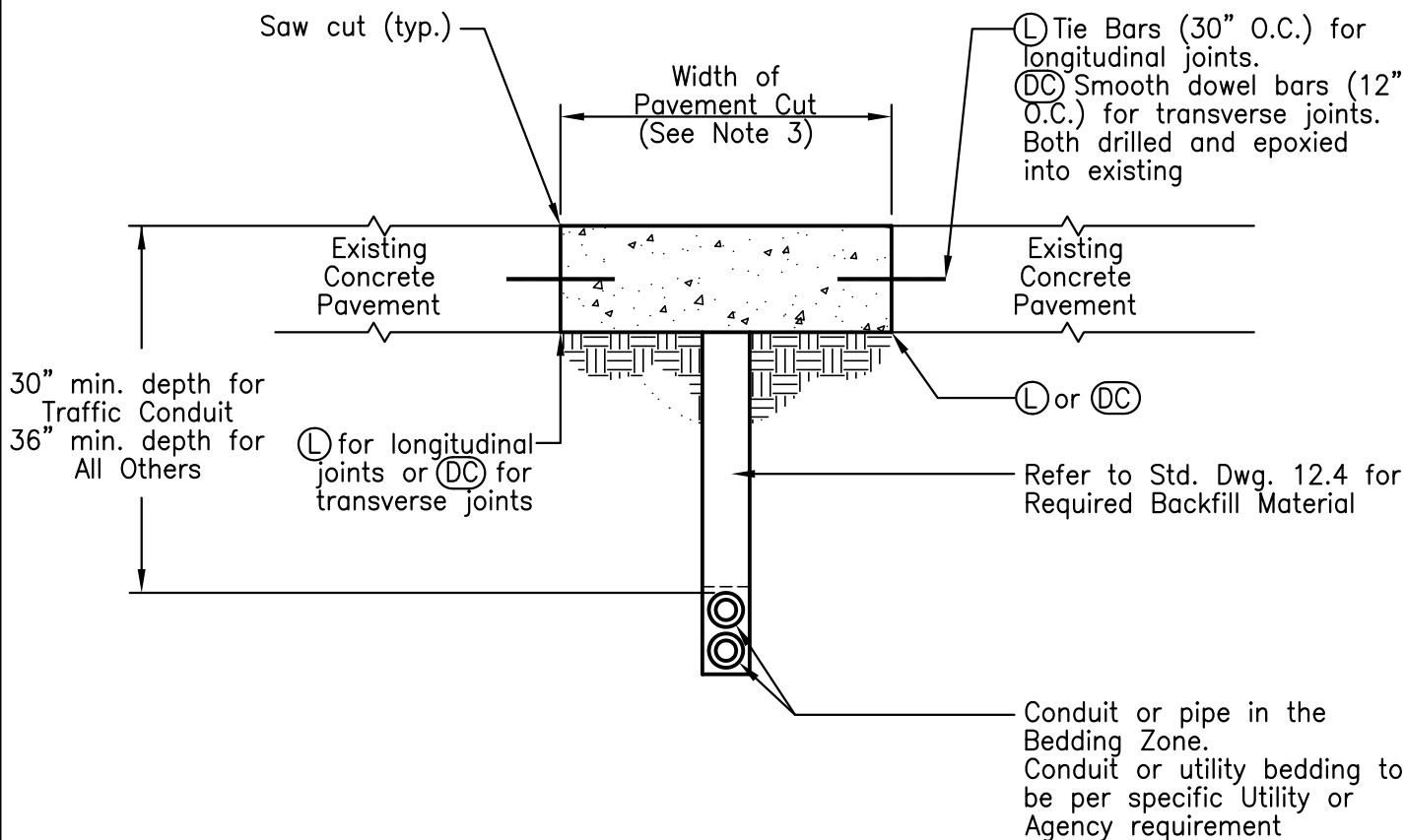

## TRENCH PATCH (CONCRETE)

### Notes:

1. Wherever possible conduit or cable shall be installed by boring, driving, or any other acceptable means under concrete units. Open cutting shall be used only under special circumstances and only with approval of PW.
2. This Standard Drawing applies to all concrete streets and alleys. Full panel replacements are required for sidewalks, curb, gutters, and driveways.
3. Full panel replacement is required when cutting or trenching into any concrete pavement.
4. A construction joint (Ⓛ) shall be used to tie the concrete patch to both existing concrete longitudinal joints. A doweled contraction joint (ⓄⓈ) shall be used at the connection into existing transverse joints. Continue existing transverse joint lines across pavement, duplicate transverse joints as (ⓄⓈ) joints.
5. The limits of concrete patching shall be perpendicular or parallel to the centerline of the street. Skewed panel replacement over trenches is not permitted.
6. Restoration of the 5' x 5' service cut in alley when the joints are more than 4 feet from existing joints, may use tie bars on all 4 sides of cut, drilled and epoxied at 18" O.C., and 9" deep into existing sides. When cut joints are less than 4 feet from existing joints, expand cut to the existing joint. Use dowels at existing transverse joint. See details for bar sizes from Std. Dwg. 11.0b.



City and County of Denver  
Transportation Standards & Details

Trench ("T") Patch (Concrete)

Date:  
04/17

Std. Dwg.  
12.3

## Backfill Materials Required per Cut or Trench Class

Reference the PW Rules and Regulations Governing Street Cuts and Roadway Excavation specifications, current version.

Cut or Trench Class	Cut or Trench Size or Structure	Backfill Materials and Method Before Test
1	Less than 150 square feet of surface cut (includes potholes for utility locates and any subsurface exploratory or monitor wells)  OR 4 inch wide to 36 inch wide. No minimum length  OR within 4 feet of structure, manhole or vault	Method A=> use Removable CLSM
2 & 3	Greater than 150 square feet of surface cut, AND Greater than 36 inches wide	Method A=> use Removable CLSM OR Method B=> approved excavated soil or import moisture adjusted and compacted**

### Method A: Requirements for Removable Controlled Low Strength Material (CLSM)

CLSM is required for Class 1 cuts or trenches, and optional for Class 2 cuts or trenches. CLSM shall be easily removable and air entrained, shall consist of an approved mix design using either flow-fill (cement and aggregate based) or flash-fill (flyash based). Both types are required to meet Removability Modulus of less than 1.5, and require different ranges of air entrainment, per MGPEC Item 19 Specifications. Refer to [www.mgpec.org](http://www.mgpec.org).

	Air Entrainment	28 day compressive strength	Flowability by Slump or Spread	Construction Criteria
Flow-Fill (normal Removeable CLSM)	6.0% min. (test by pressure method or unit weight method)	50 psi minimum to 150 psi maximum	Slump (C143) 7" to 10"	Limit 3 feet thick. Between placements, push water OFF surface before adding more.

OR

Flash-Fill (fast set Removeable CLSM)	Permanent 15.0% min. (test by unit weight method)	50 psi minimum to 300 psi maximum	Spread (D6103) 8" min., or Slump (C143, one lift, no rodding) 7" to 10"	Protect from bonding to conduits, pipes, or pavement openings.
---------------------------------------	---	-----------------------------------	---	--

### Method B: Approved Reuse of Excavated Materials or Import

Requirements for Reuse of Excavated Materials in Trench Backfill: materials shall be free of organics, trash, hazardous materials, rock or bedrock more than 3" diameter, high clay content (Plasticity Index (PI) shall be no more than 20), and soft or wet materials.

Before test refer to the specific Utility or Agency Specifications or Standards for pipe bedding and backfill material and construction requirements for lift thickness, moisture, and compaction. Compaction must be verified by tests.

	City and County of Denver Transportation Standards & Details	Date: 04/17
	Trench Backfill Material Requirements	Std. Dwg. 12.4

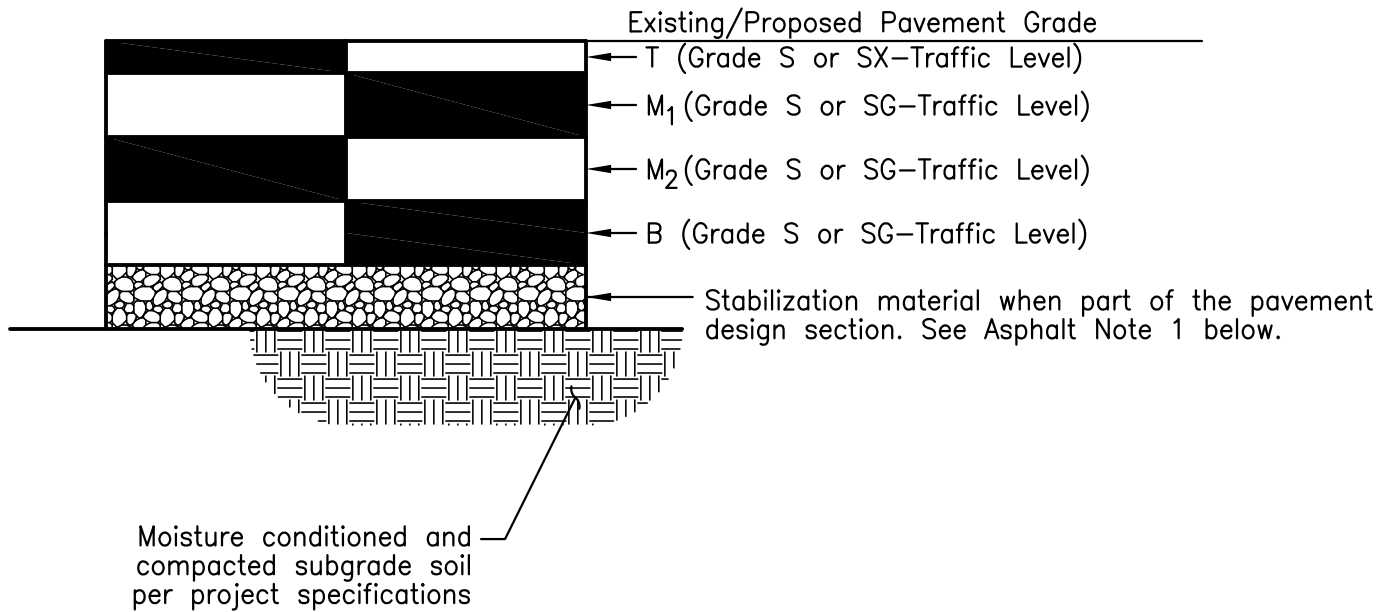

## TYPICAL ASPHALT LAYER DETAIL – HOT MIX ASPHALT (HMA)

### New Roadway Notes

1. A pavement design prepared by a qualified Geotechnical Engineer shall be submitted for new roadways to be constructed, or as otherwise required by PW.
2. Table 12.6-2 on Std. Dwg. 12.6 shall be applied for design of constructed lift thickness.

### Existing Roadway Reconstruction Notes

1. A pavement design prepared by a qualified Geotechnical Engineer may be submitted for existing roadways to be reconstructed, in lieu of minimum requirements shown on Table 12.7-1 on Std. Dwg. 12.7.

### Asphalt Notes:

1. For full depth reconstruction, asphalt thickness shown as full depth. Aggregate base course (ABC) may be substituted 4" ABC for 1" asphalt up to 12" ABC of full depth asphalt per the pavement design only when the subgrade soils are non-swelling. Minimum depth of asphalt on ABC is 5" for local streets, 9" for collectors and arterial streets.
2. Tack coat shall be applied between each asphalt layer unless the engineer determines the existing exposed layer is adequately sticky without a tack coat.
3. All asphalt to meet MGPEC Item 20 specifications. ([www.mgpec.org](http://www.mgpec.org))
4. When an existing street in good condition needs (lowering) less than 12 inches in elevation and for less than 650 feet in length, it may be reconstructed with a minimum thickness matching existing adjacent asphalt and base course. Contact Dept. ROW Inspector for assessment of existing condition approval.



City and County of Denver  
Transportation Standards & Details

Typical Asphalt Pavement Detail

Date:  
04/17

Std. Dwg.  
12.5

LIFT THICKNESS BASED  
UPON MIX GRADING

Table 12.6-1

Mix Grading (nominal size)	Absolute Minimum Lift Thickness (3 x nominal size)	Recommended Lift Thickness (4 x nominal size)	Maximum Lift Thickness is limited by compaction equipment and crew's ability
SX (1/2")	1.5"	2.0"	3.0"
S (3/4")	2.3" -> use 2.5"	3.0"	4.0"
SG (1")	3.0" -> use 3.5"	4.0"	5.0"

COMBINATIONS OF LIFT THICKNESSES TO ACHIEVE THE FULL  
DEPTH SECTION WITH HEAVY MAIN LINE PAVING EQUIPMENT

Table 12.6-2

Full Depth HMA	Top Lift (T)	Bottom Lift (B)	or	Top Lift (T)	Upper Mid-Lift (M <sub>1</sub> )	Lower Mid-Lift (M <sub>2</sub> )	Bottom Lift (B)
6.0	2.0	4.0	or	3.0	N/A	N/A	3.0
6.5	2.5	4.0	or	3.0	N/A	N/A	3.5
7.0	3.0	4.0		2.5	N/A	N/A	4.5*
7.5	3.0	4.5*		3.0	N/A	N/A	4.5*
8.0	3.0	5.0*		2.0	3.0	N/A	3.0
9.0	N/A	N/A		2.0	3.0	N/A	4.0
10.0	N/A	N/A		2.0	4.0	N/A	4.0
11.0	N/A	N/A		3.0	4.0	N/A	4.0
12.0	N/A	N/A		3.0	3.0	3.0	3.0
13.0	N/A	N/A		3.0	3.0	3.0	4.0
14.0	N/A	N/A		3.0	3.0	4.0	4.0
15.0	N/A	N/A		3.0	4.0	4.0	5.0*

Note: For 0.5" increments add or subtract 0.5" to a lift

\*Indicates SG grading mix shall be used at these thicknesses in lieu of S grading, based on contractor's ability to achieve compaction.

Note:

- Contractor must select proper compaction equipment and techniques to achieve required compaction in all cases. Compaction specification is 92% to 96% of Rice Value (maximum theoretical density).



City and County of Denver  
Transportation Standards & Details

Typical Asphalt Pavement Detail  
Lift Thickness Criteria

Date:  
04/17

Std. Dwg.  
12.6

**DEFAULT ASPHALT PAVEMENT DESIGN CRITERIA AND MINIMUM THICKNESS BY ROADWAY**

Table 12.7-1

**CLASSIFICATION FOR RECONSTRUCTION OF EXISTING STREETS**

	Traffic Level					Industrial
	Residential	Collector		Heavy Collector (Truck or Bus Route)	Arterial	
Design Lane ESALS Minimum, unless designer performs a vehicle classification per MGPEC Pavement Design Standards	70,000 + 80 x num. of new dwelling units to be constructed	100,000**	500,000***	3,000,000	5,000,000	Must perform MGPEC Pavement Design www.mgpec.org
Minimum total full depth asphalt section (T+M+B) without MGPEC compliant geotechnical or pavement thickness design*	7.0"	7.5"***	10.0"***	13.5"	14.5"	14.5" or per pavement design

\* Or match existing, whichever is greater

\*\* Local collector residential only

\*\*\* Local collector with added commercial uses or has RTD bus route, or takes commercial traffic

Table 12.7-2

**REQUIRED ASPHALT MATERIALS-BY LIFT**

		Traffic Level					Industrial
		Residential <100,000 ESALs	Collector	Heavy Collector (Truck or Bus Route)	Arterial		
Top Lift (T)	Asphalt Mix Grading (nominal size)	SX (1/2")	SX (1/2")	SX (1/2")	SX (1/2")	SX (1/2")	SX (1/2"), or S (3/4") by permission of PW
	Mix Design Gyration Compaction Effort Level	N=75	N=75	N=100	N=100	N=100	N=100 or N=125 (from design)
	Asphalt Binder Grade (PG hh-II)	PG 58-28	*PG 58-28 with low traffic **PG 64-22 with high traffic	PG 64-22	PG 76-28 (polymer modified), if available. Use PG 64-22 if not.	PG 64-22 or by design	
Lower Lifts (M1) (M2) (B)	Asphalt Mix Grading (nominal size)	S (3/4") or SG (1.0") Note: 1	S (3/4") or SG (1.0") Note: 1	S (3/4") or SG (1.0") Note: 1	S (3/4") or SG (1.0") Note: 1	S (3/4") or SG (1.0") Note: 1	S (3/4") or SG (1.0") Note: 1
	Mix Design Gyration Compaction Effort Level	N=75	N=75	N=100	N=100	N=100	N=100 or N=125
	Asphalt Binder Grade (PG hh-II)	Same as for top lift	Same as for top lift	PG 64-22 Note: 2	PG 64-22 Note: 2	PG 64-22 Note: 2	PG 64-22 Note: 2

\* PG 58-28 if no buses, no commercial use

\*\* PG 64-22 if has RTD bus route or takes commercial traffic

Notes:

- Grading SG may be allowed based upon ability of paving operation to obtain required percent of Rice compaction, proper lift thickness, and sufficient length of paving. Not to be used when hand placement or moving is necessary that would result in segregation.
- A one-grade softer binder may be allowed on lower lifts to meet "Perpetual Pavement" designs.

	City and County of Denver Transportation Standards & Details	Date: 04/17
	Typical Asphalt Mix Details by Traffic Use or Lift Position	Std. Dwg. 12.7

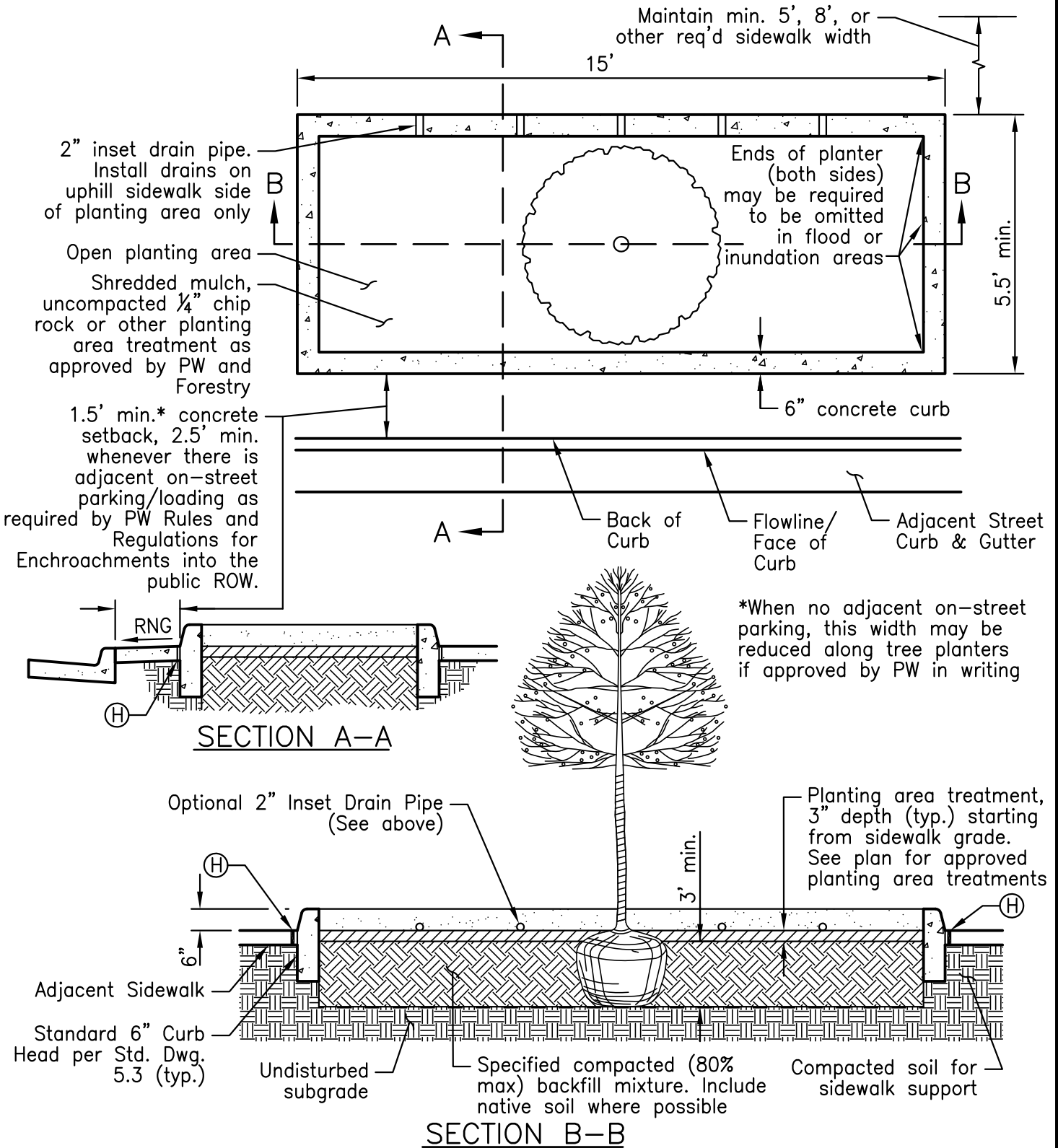

Notes:

1. Tree planting per Office of the City Forester standards and specifications.
2. For all new installations, automatic irrigation system shall be provided in open planting area.
3. Concrete jointing and scoring outside open planting area shall be coordinated with PW field staff.

	City and County of Denver Transportation Standards & Details	Date: 04/17
	Tree Planter (Raised Curb)	Std. Dwg. 13.0



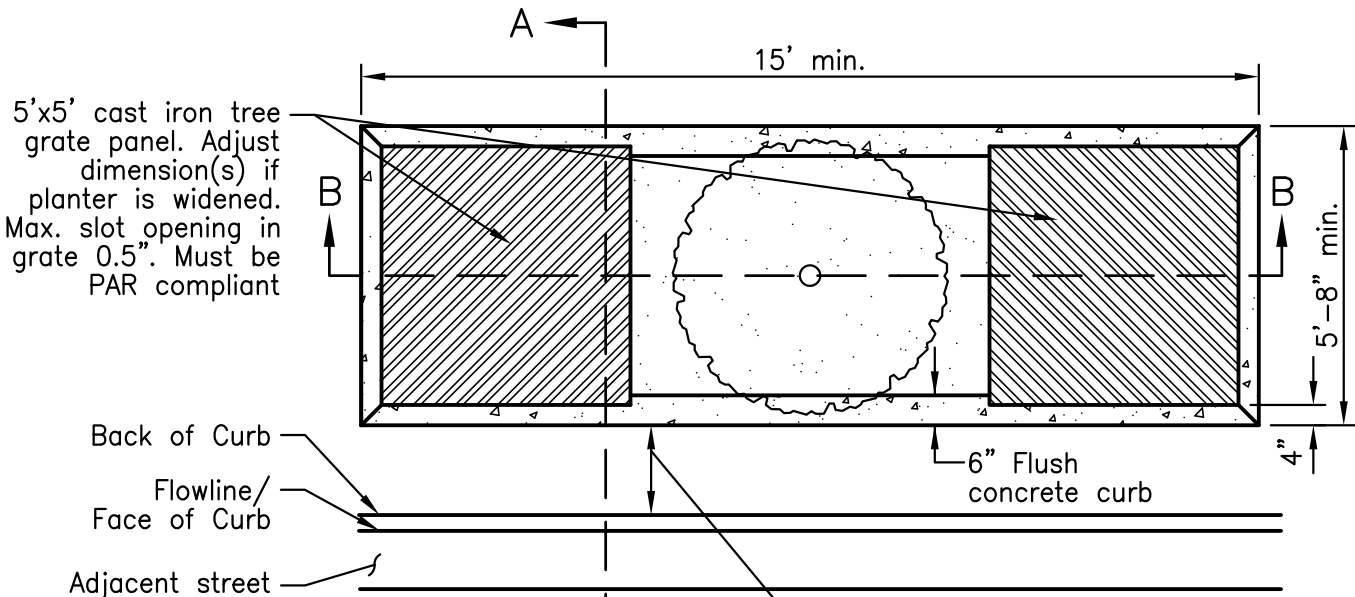

5'x5' cast iron tree grate panel. Adjust dimension(s) if planter is widened. Max. slot opening in grate 0.5". Must be PAR compliant

Back of Curb  
Flowline/  
Face of Curb  
Adjacent street curb & gutter

6" Flush concrete curb

Provide 1.5' min. concrete setback as required by PW Rules and Regulations for Encroachments into the public ROW. This width may be reduced along tree planters if approved by PW in writing

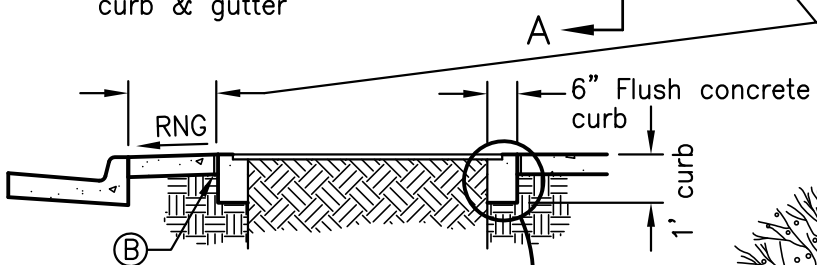

SECTION A-A

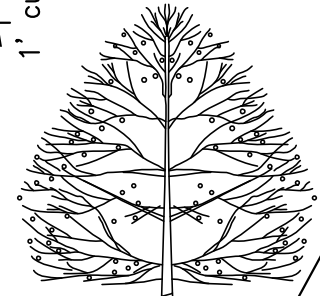
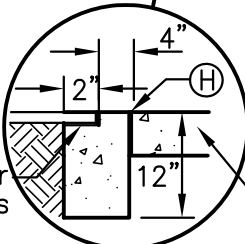

Set root collar at or 1" above sidewalk grade. Remove excess soil from top of root ball

Shredded wood mulch, 3"-4" depth and 4"-6" away from trunk or uncompacted 1/4" chip rock as approved by PW and Forestry

Continuous grate bracket per manufacturer's specifications

Maintain min. 1"-2" gap between bottom of grate and finish grade. Fill remaining gap with shredded wood mulch.

Adjacent Existing Walk

PAR compliant cast iron tree grating, 0.5" max. slot opening

Undisturbed subgrade

Specified compacted (80% max) backfill mixture. Include native soil where possible

Compacted soil for sidewalk support

SECTION B-B

Notes:

1. Tree planting per Office of the City Forester standards and specifications.
2. For all new installations, automatic irrigation system shall be provided in open planting area.
3. Concrete jointing and scoring outside open planting area shall be coordinated with PW field staff.

	<p>City and County of Denver Transportation Standards &amp; Details</p>	<p>Date: 04/17</p>
	<p>Tree Planter (Grates)</p>	<p>Std. Dwg. 13.1</p>

**Notes:**

1. This detail is for use adjacent to commercial properties where the streetscape area is generally hardscaped.
2. No adjustment of the sidewalk clear width is allowed between properties, it must be continuous.
3. Amenity zone:
  - Can include, but not limited to: trees/grates, parking meters, bus shelters, bike racks, misc. street furniture. Refer to the Rules and Regulations for Encroachments in the ROW.
  - Space bike racks 4' min. from tree trunks.
4. Step-out/Set Back Zone:
  - Any encroachment placed in the R.O.W. must be located a minimum of 2'\* from the face of curb, unless otherwise approved by PW. Continuous encroachments shall be placed a minimum of 3' from face of curb whenever there is adjacent on-street parking.
5. Meters shall be installed in step-out/separation zone and shall not be directly adjacent to tree trunks.

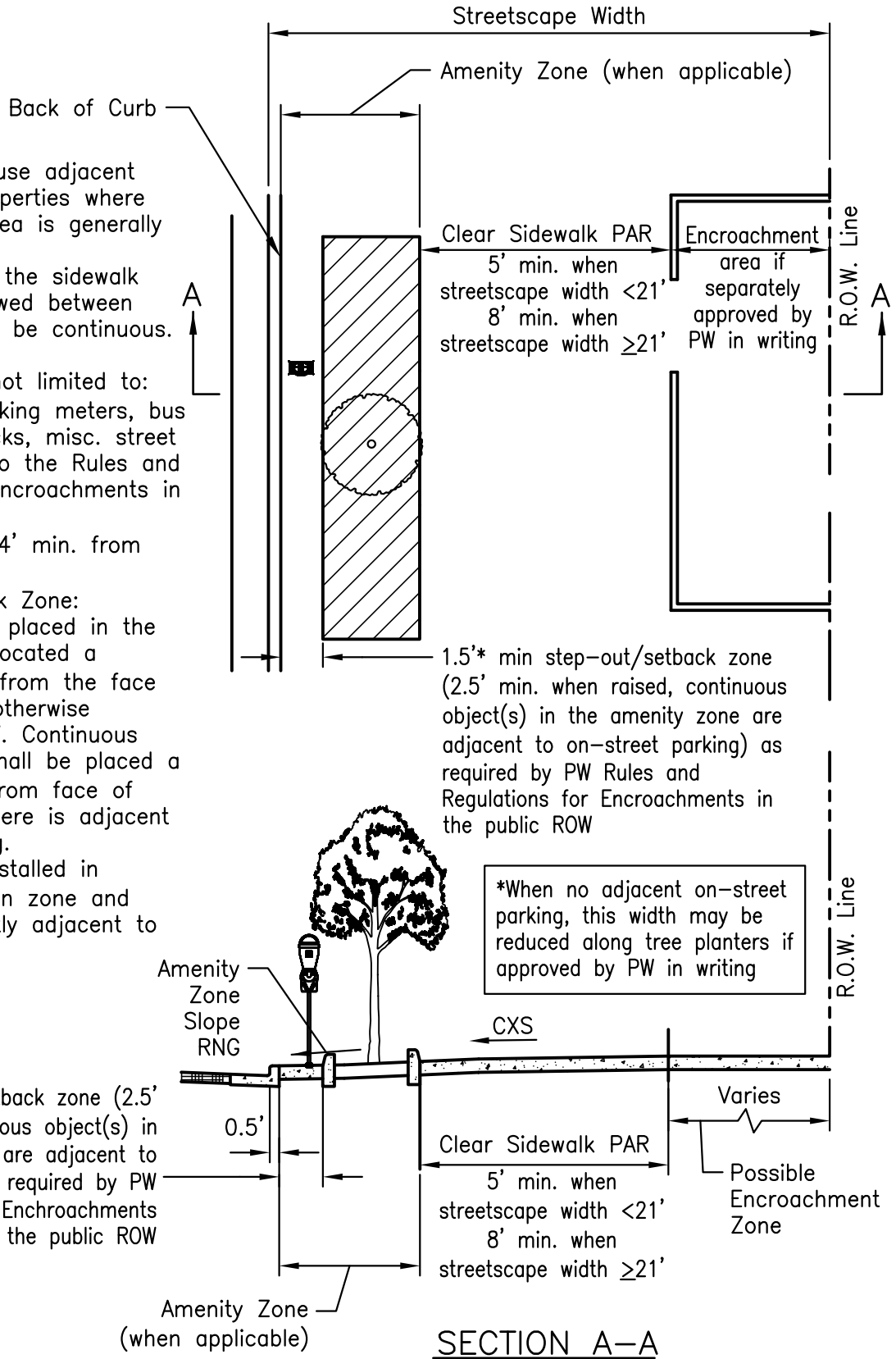

1.5'\* min step-out/setback zone (2.5' min. when raised, continuous object(s) in the amenity zone are adjacent to on-street parking) as required by PW Rules and Regulations for Encroachments in the public ROW

**SECTION A-A**

	City and County of Denver Transportation Standards & Details	Date: 04/17
	Sidewalk Clear Zones	Std. Dwg. 13.2

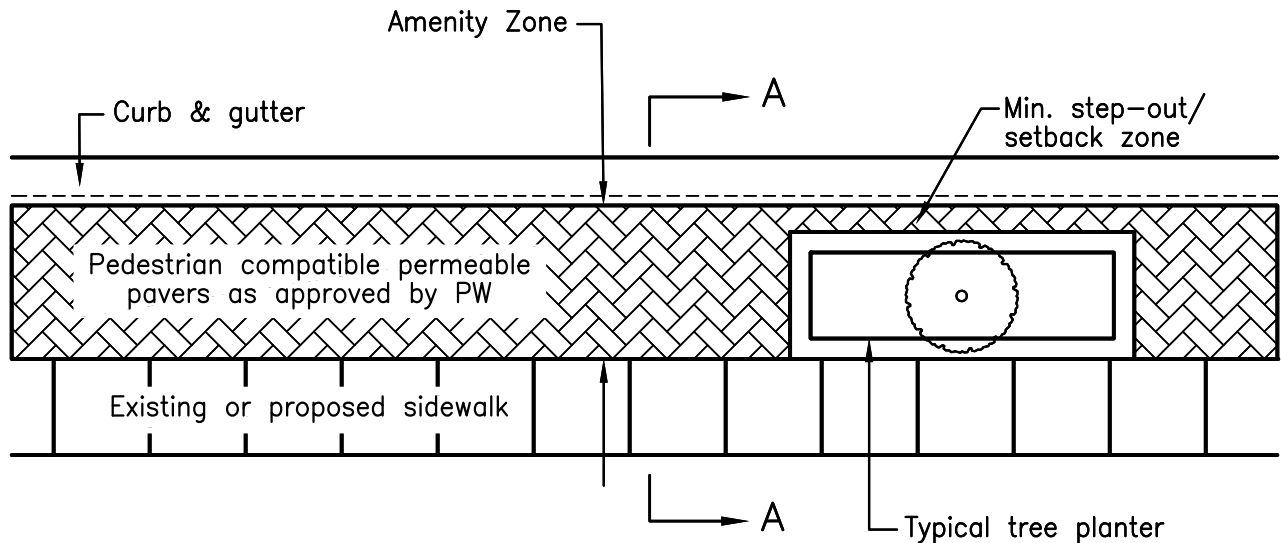

PERMEABLE PAVERS IN AMENITY ZONE WHEN ADJACENT TO  
6" CURB & GUTTER WITH DETACHED SIDEWALK

Not intended for Water Quality Capture Volume (WQCV) Credit. Any proposed permeable paver system shall be designed and submitted to PW for approval in writing prior to construction.

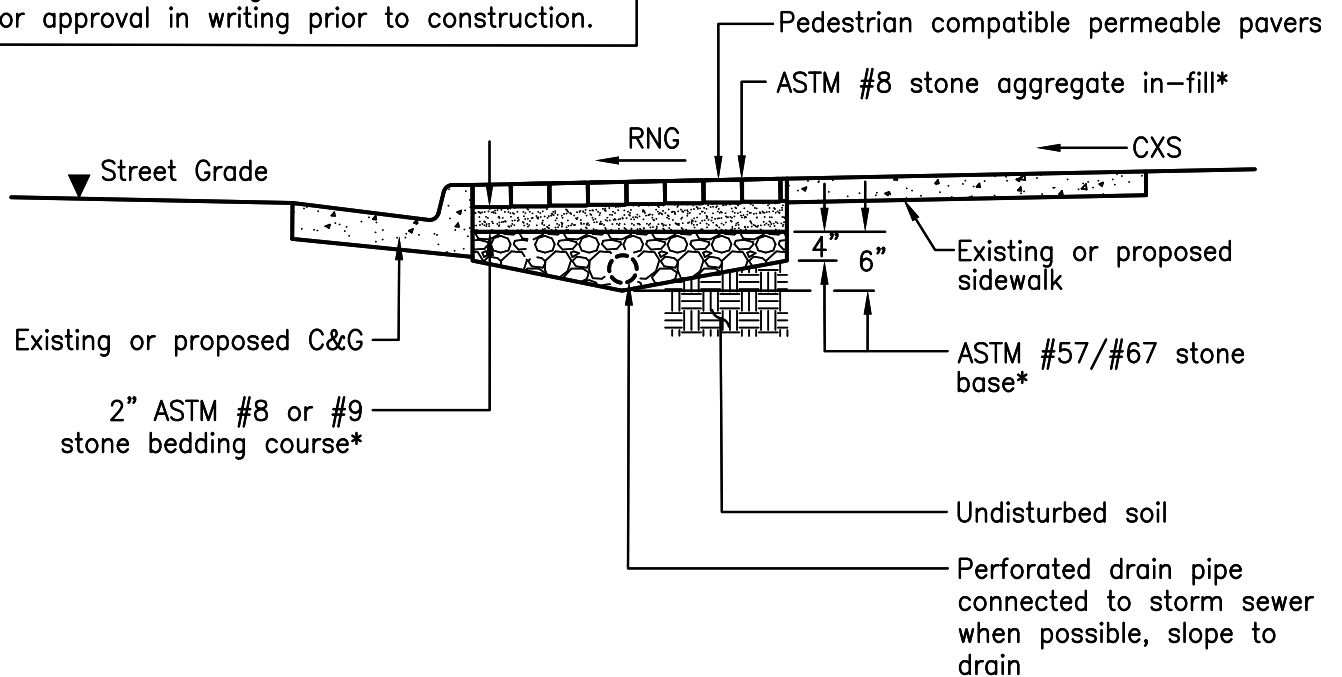

SECTION A-A

\* Or per manufacturer recommendations as approved by PW



City and County of Denver  
Transportation Standards & Details

Date:  
04/17

Amenity Zone Permeable Pavers

Std. Dwg. No.  
13.3

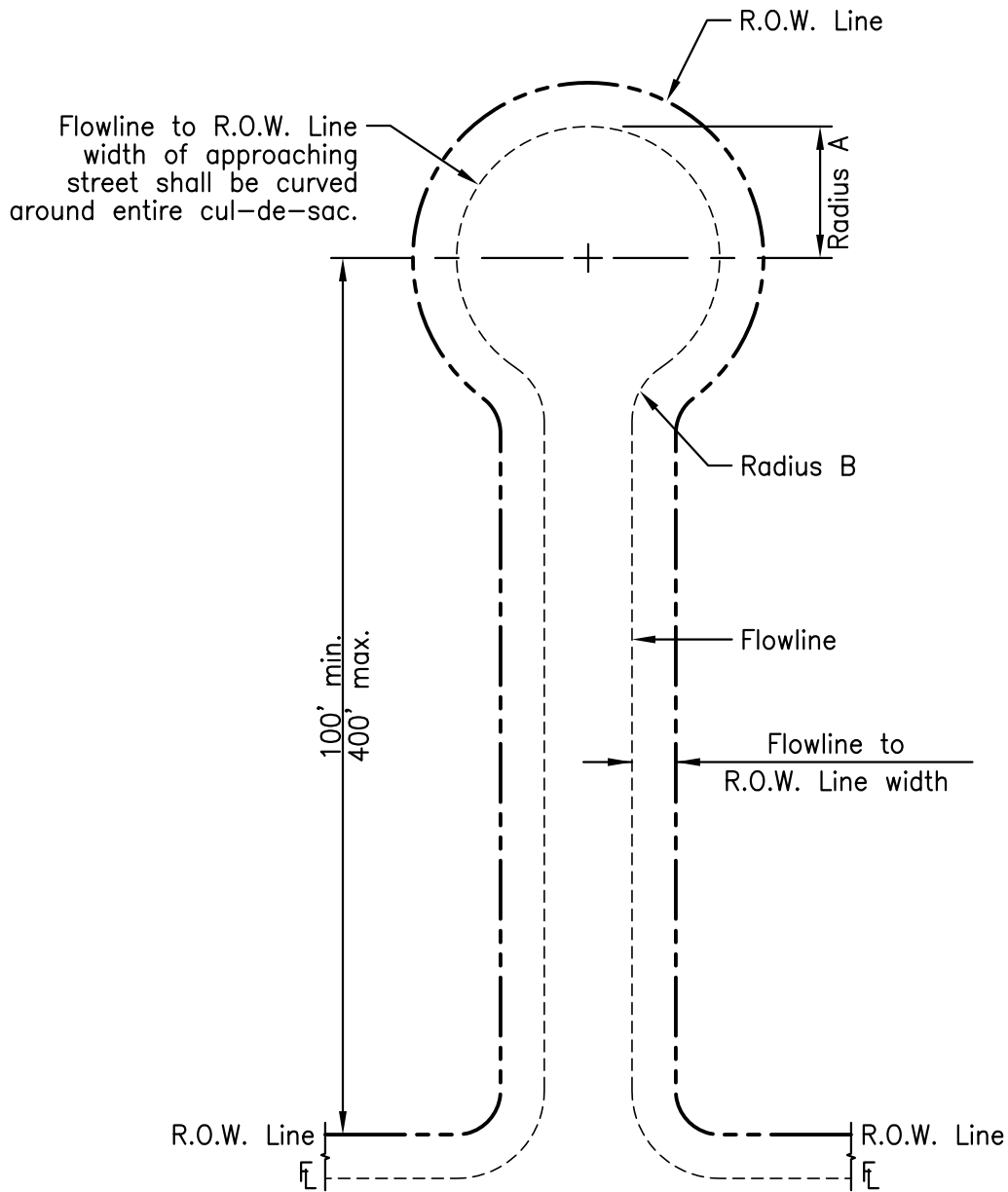

**STANDARD CUL-DE-SAC**  
Only allowed on local streets

Street Class	Radius	
	A	B
Residential*	45'	25'
Industrial**	57'	30'

\*Based on SU-30 turning radius  
\*\*Use Industrial dimensions if any adjacent property is zoned industrial

Notes:

1. New cul-de-sacs must be approved by PW.
2. R.O.W. Line may vary based on specific site conditions.
3. Hammer-head turnarounds are not permitted on public roadways.



City and County of Denver  
Transportation Standards & Details

Standard Cul-de-Sac

Date:  
04/17

Std. Dwg.  
14.0

RANGE POINTS ARE SURVEY MONUMENTATIONS USED TO PERMANENTLY ESTABLISH AND PRESERVE THE PUBLIC RIGHTS OF WAY IN THE CITY AND COUNTY OF DENVER. THIS PRACTICE HAS BEEN IN EFFECT IN THE CITY SINCE THE LATE 1800s. SEE ORDINANCE 41 SERIES 1886.

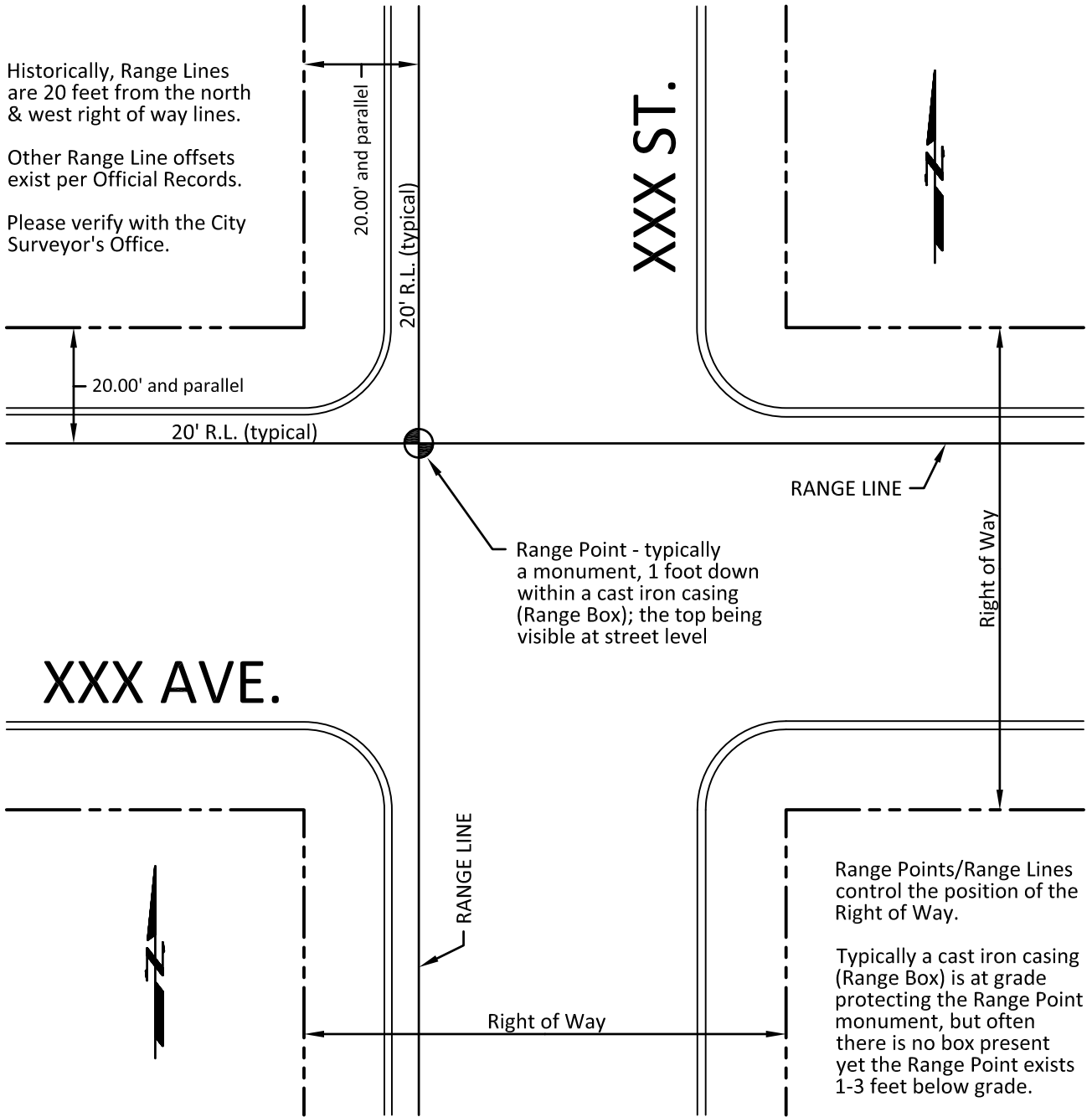

Note that all existing range points shall be protected and preserved. If any range point is disturbed by any activity, it shall be properly restored per Range Point Guidelines, found at: <https://www.denvergov.org/survey>



City and County of Denver  
Transportation Standards & Details

Right-of-Way Survey Control  
\*\*Range Points\*\*

Date:  
04/17

Std. Dwg.  
15.0