

**HERCULES**  
**HHS**  
HIGH SECURITY

**HERCULES**  
**FENCE**

**HERCULES**  
**HCI**  
CUSTOM IRON

**"Security in Every Job"**  
*Since 1955*



**EL-GO TEAM**  
SECURITY SYSTEMS



**THE PREMIER PARTNER AND EXCLUSIVE US  
DISTRIBUTOR OF EL-GO METIS BOLLARDS**



# METIS SLIDING SECURITY BOLLARD

---

**EL-GO TEAM MEETS ALL THE  
★ NECESSARY CRASH RATING & ★  
QUALITY STANDARDS**



# EL-GO TEAM - METIS SLIDING BOLLARDS

**METIS is an innovative all-electric high-security sliding bollards system.**

**METIS has a unique all-electric drive unit, with a simple and reliable chain drive system.**

**METIS has a K4 crash test rating.**

**METIS is truly "plug & play", mounted on any concrete pad thicker than 200 mm using common anchor bolts and installed within the same day.**



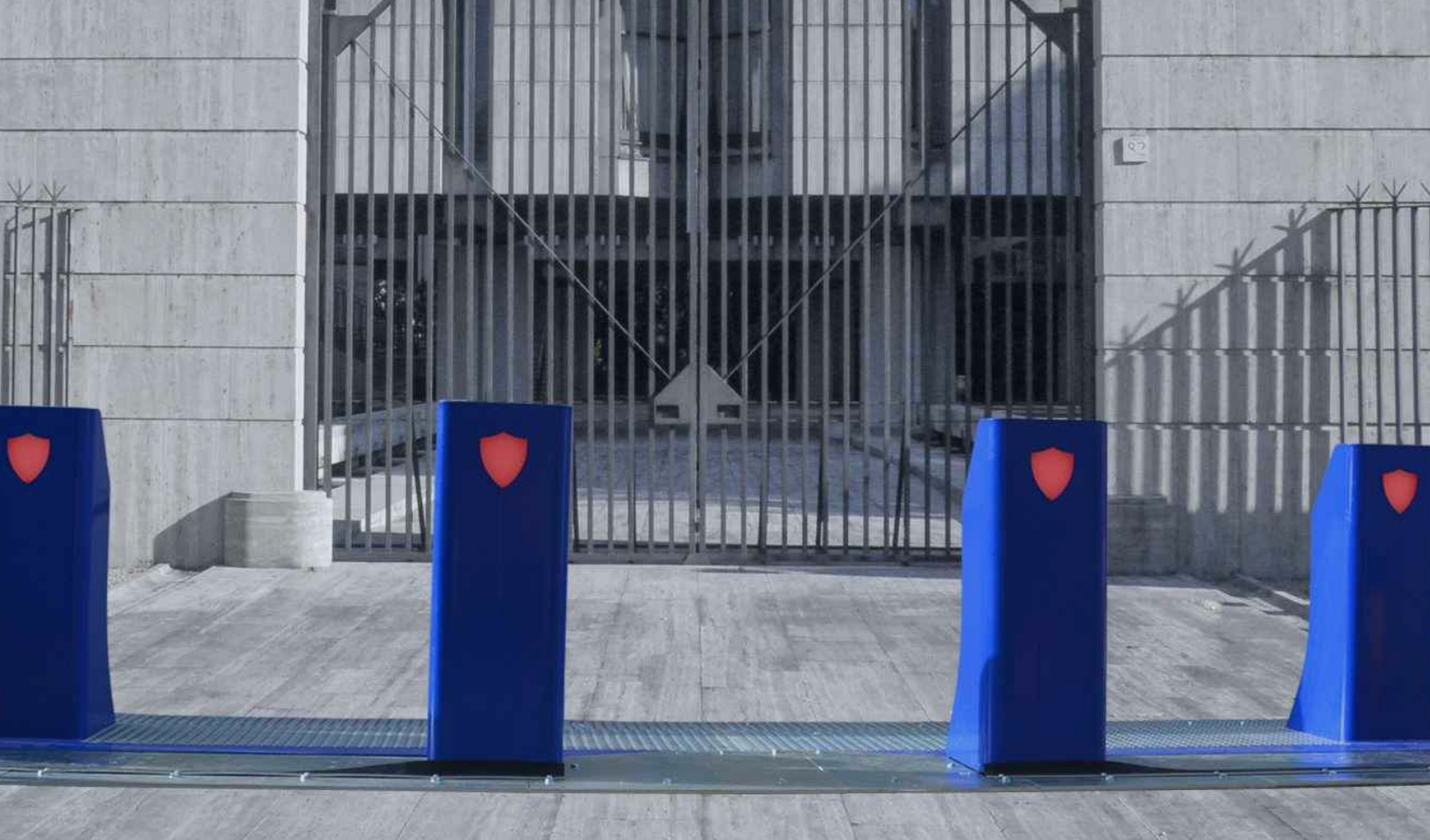

**BUILT IN INVISIBLE  
SAFETY SENSORS.  
MAXIMUM SAFETY  
WITH MAXIMUM  
SECURITY.**

**FULL MANUAL  
OPERATION IN CASE  
OF POWER OUTAGE.**

**BUILD-IN CONTROL  
CABINET - NO WIRING  
ON SITE, NO LIMIT  
SWITCH CALIBRATION.**

**FEW HOUR  
INSTALLATION – JUST  
DRILL SOME ANCHORS,  
PLUG THE POWER IN,  
AND YOU ARE DONE!**





**EL-GO TEAM**  
SECURITY SYSTEMS

WE KNOW SECURITY

## METIS – K4 Electric sliding bollards

### User Manual

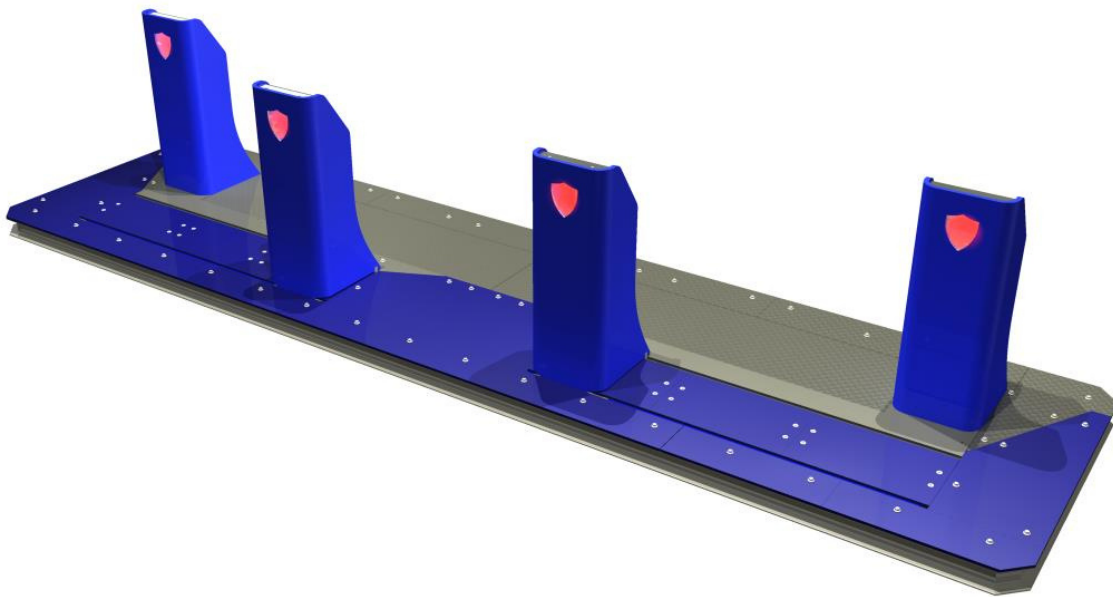

ELGOTEAM LTD

Po Box 1036, Even Yehuda 40500, IL | Tel: +972-9-8943466 | Fax: +972-9-8943555 | [info@elgoteam.com](mailto:info@elgoteam.com) | [www.elgoteam.com](http://www.elgoteam.com)



Table of contents:

1.Warnings ..... 2

2.Maintenance..... 3

3.Common troubleshooting procedures..... 6

4.Limit switches calibration.....7

5.Chain tension system..... 9

6.Manual operation..... 10

7.Replaceable parts list..... 11

8.Addons..... **Error! Bookmark not defined.**

1. Warnings

warnings
Never lean, sit or stand on the bollard.
Do leave any obstacle in the bollards path.
Do not paste stickers anywhere on the bollard.
Keep the bollard environment clean.
Never Operate the bollard while people walking around.
Never operate the bollard while vehicles on it.
If the product is damaged or has a non-working problem, cut off the power supply. Only skilled technicians must make repairs or maintenance of the product.
This product should be used for the purpose it is designed for. Dangerous causes may happen in case of usage other than the usage that manufacturer states. In that case, manufacturer takes no responsibility.
Cut off the power of the product when maintenance is needed.
Power supply source must include circuit breaker provides overcurrent protection



## 2. Maintenance

### Maintenance actions have to be done daily:

Component	Operation	Notes
General	Visual check	Make sure all components are in place Make sure the bollards path is clean.

### Maintenance actions have to be done monthly:

Component	Operation	Notes
General	Bolt tightening	All bolts must be tightened (as can be seen in Picture 3)

### Maintenance actions have to be done every 6 months:

Component	Operation	Notes
General	visual check Cleaning Oil applying	Open the back cover from the control cabin inside the fixed bollard and turn the power off. Open All cover bolts (as can be seen in Picture 3) , 1. Clean the inside from all foreign debris. 2. Apply PTFE oil all over the chains. 3. Tight chains tension if needed according to chapter 5. Chain tension system. 4. Check for any dirt or foreign bodies to disturb the bollards .

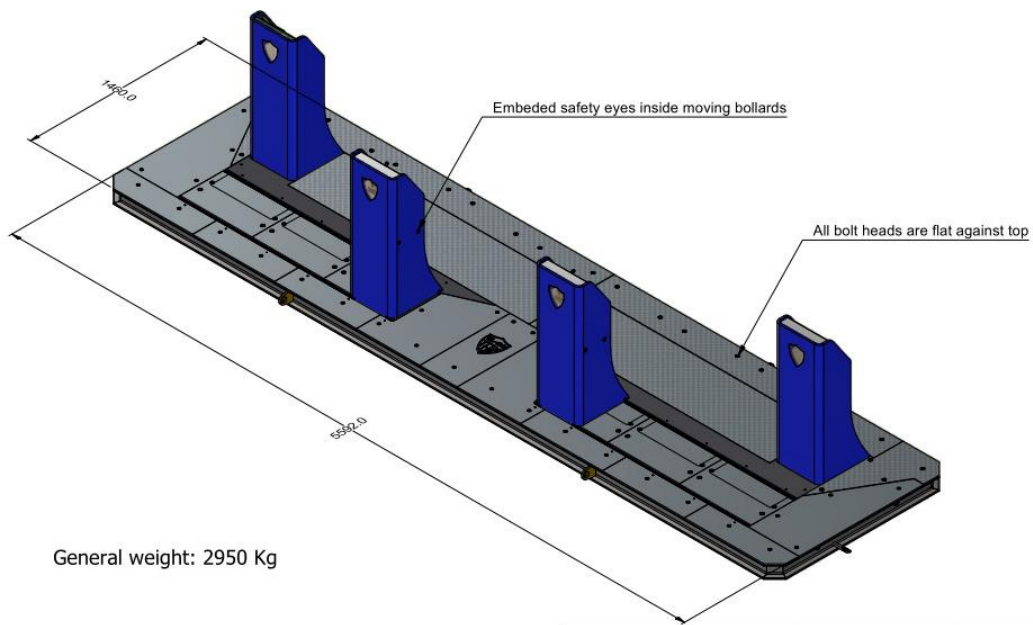

Picture1 -General overview

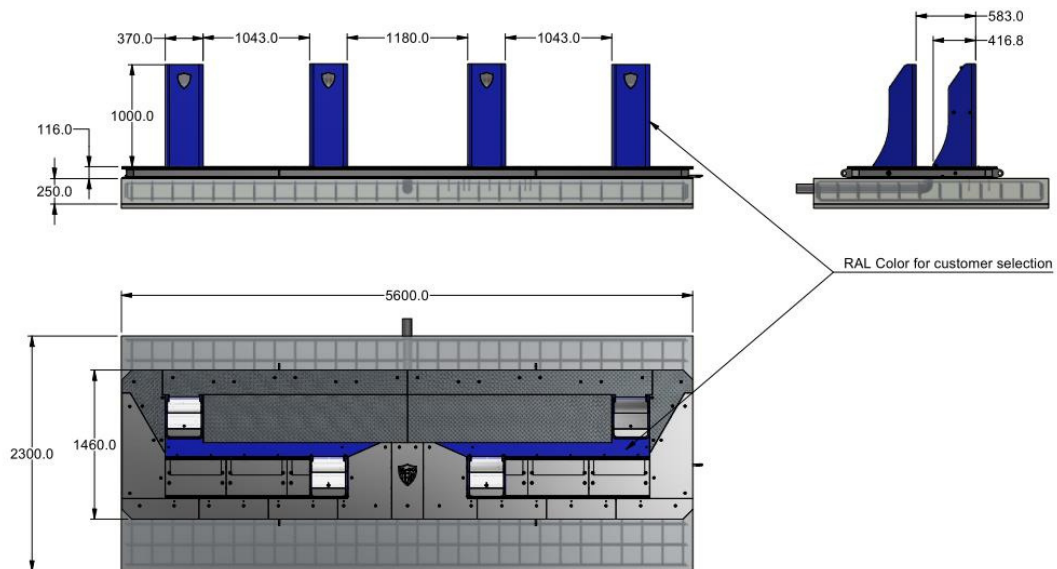

Picture 2 - General Dimensions



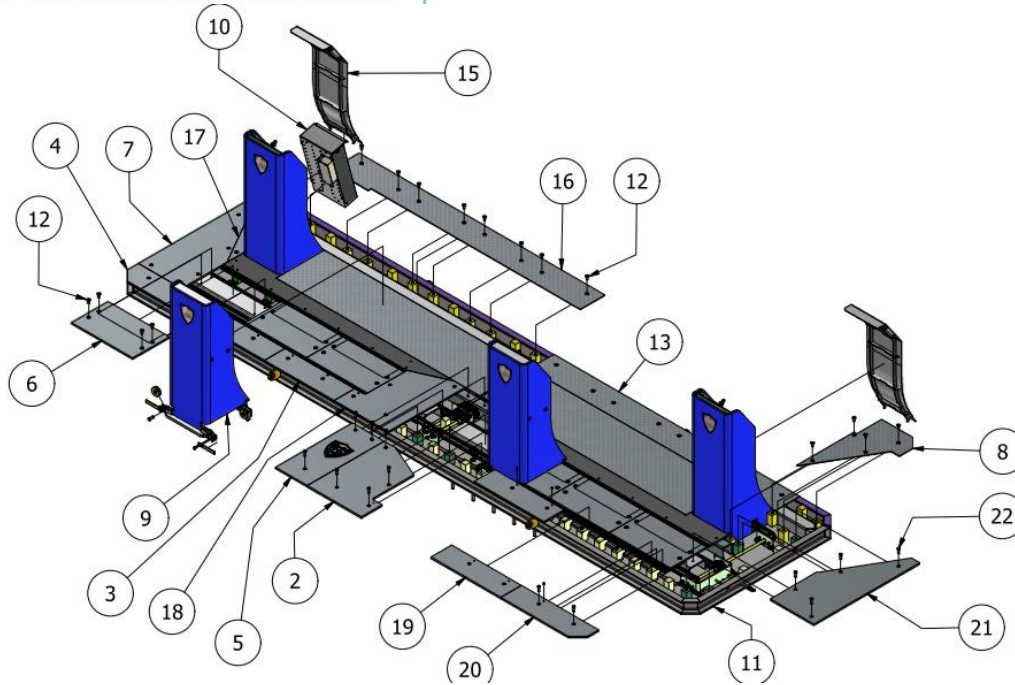

Picture 3 - General assembly

BILL OF MATERIAL LIST			
ITEM	PART No.	QTY	DESCRIPTION
1	BLG-Metis-101BB-Body	1	Bearrings,sprockets, axis Drive modul assembly
2	BLG-Metis-3302-CoverL	1	Middle side cover t-12
3	BLG-Metis-3303-CoverR	2	Front cover t-12
4	BLG-Metis-3304-CoverR	1	Front corner cover t-12
5	BLG-Metis-3305-Cover	1	Logo middle cover t=12
6	BLG-Metis-301-Cover	6	Middle rail cover t-12 AISI 1045
7	BLG-Metis-3307-CoverR	1	Side cover t-12
8	BLG-Metis-3308-CoverL	1	Side marog cover t-4
9	BLG-Metis-299A-Bollard	2	Slide bollard assembly
10	BLG-Metis-400A-Control	1	Control board
11	BLG-Metis-102AA2-Body	1	Main body weld
12	DIN 7991 - M12x30	47	Hexagon socket countersunk head cap screws
13	BLG-Metis-3311-CoverL	1	Marog back cover t-4
15	BLG-Metis-291F2-Bollard	2	Bollards back cover weld
16	BLG-Metis-3311-CoverR	1	Marog back cover t-4
17	BLG-Metis-3308-CoverR	1	Side marog cover t-4
18	BLG-Metis-3302-CoverR	1	Middle side cover t-12
19	BLG-Metis-3303-CoverL	2	Front cover t-12
20	BLG-Metis-3304-CoverL	1	Front corner cover t-12
21	BLG-Metis-3307-CoverL	1	Side cover t-12
22	DIN 7984 - M12 x 35	30	Cylinder Head Cap Screw



### 3. Common troubleshooting procedures

- **Only a trained technician allowed doing troubleshooting!**
- **Turn the main power off before you make any procedure.**

Problem	Solution		Notes
1. Bollard doesn't move And motor doesn't work when Close/Open button is pressed.	Please check in control cabin if the signal goes through the relay to the Emmerson controller and check if the control unit is in on position (as can be seen in picture 4). Check open / close limit switches are triggered. In case of synchronization with arm barrier please check if <b>arm barrier</b> operates properly, if not see arm barrier manual.		
2. Bollard doesn't move While motor is working.	There is a mechanical interference. Open the covers to find it.		
3. Bollard goes all the way into open/Close position and motor keeps on working.	Limit switch is not calibrated or not triggered. Open covers in order to calibrate it according to chapter 4. <a href="#">Limit switches calibration.</a>		
4. Controller overload	In some cases, the controller may go into overload error mode. You will see it on the controller screen. The action needed is a reset for the system in the control cabin.		
<b>In case none of the procedures helps please contact your vendor for help.</b>			



Picture 4 - Control cabin



#### 4. Limit switches calibration

In Order to calibrate the limit switches, First open both covers as can be seen in [picture 5](#), You can adjust the limit switch itself or the trigger tongue as can be seen in [picture 8](#). **Make sure the power is off while you make adjustments.**

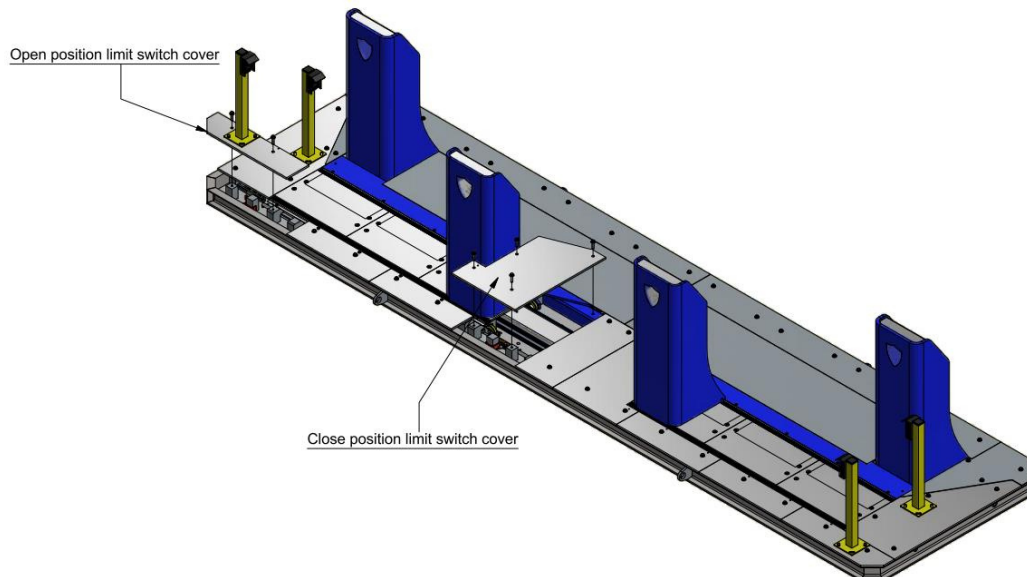

Picture 5 - Limit switches covers

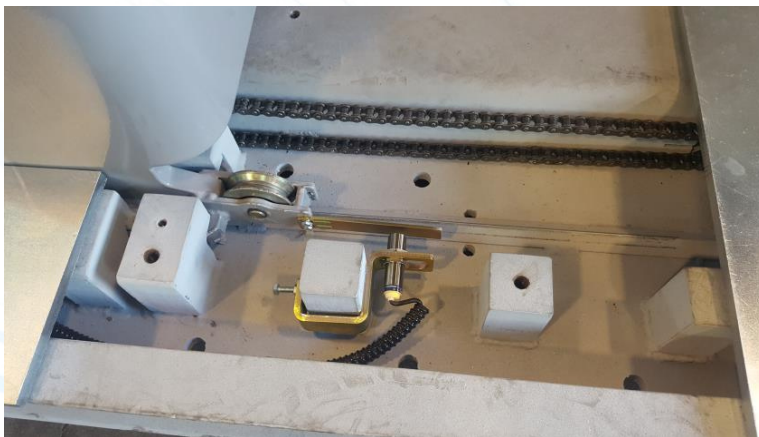

Picture 6 - Close limit switch



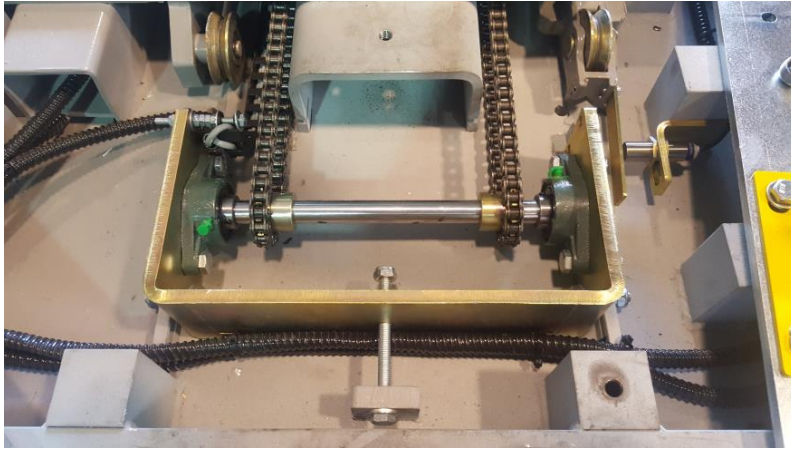

Picture 7 - Open limit switch

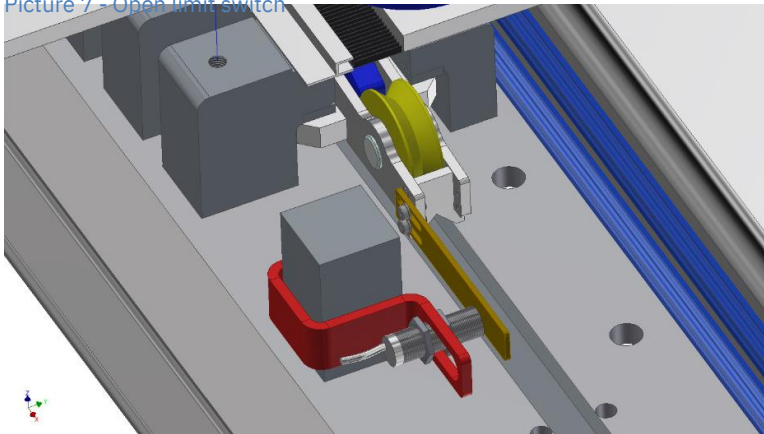

Picture 8 - Limit switch and trigger tongue



## 5. Chain tension system

In order to apply tension to the chain if needed, first open covers #25 and #26 as can be seen in [picture 9](#). Open 6 bolts and nuts #7&8. Use bolt #40 to apply moderate tension to the chain. Then lock back all bolts and nuts.

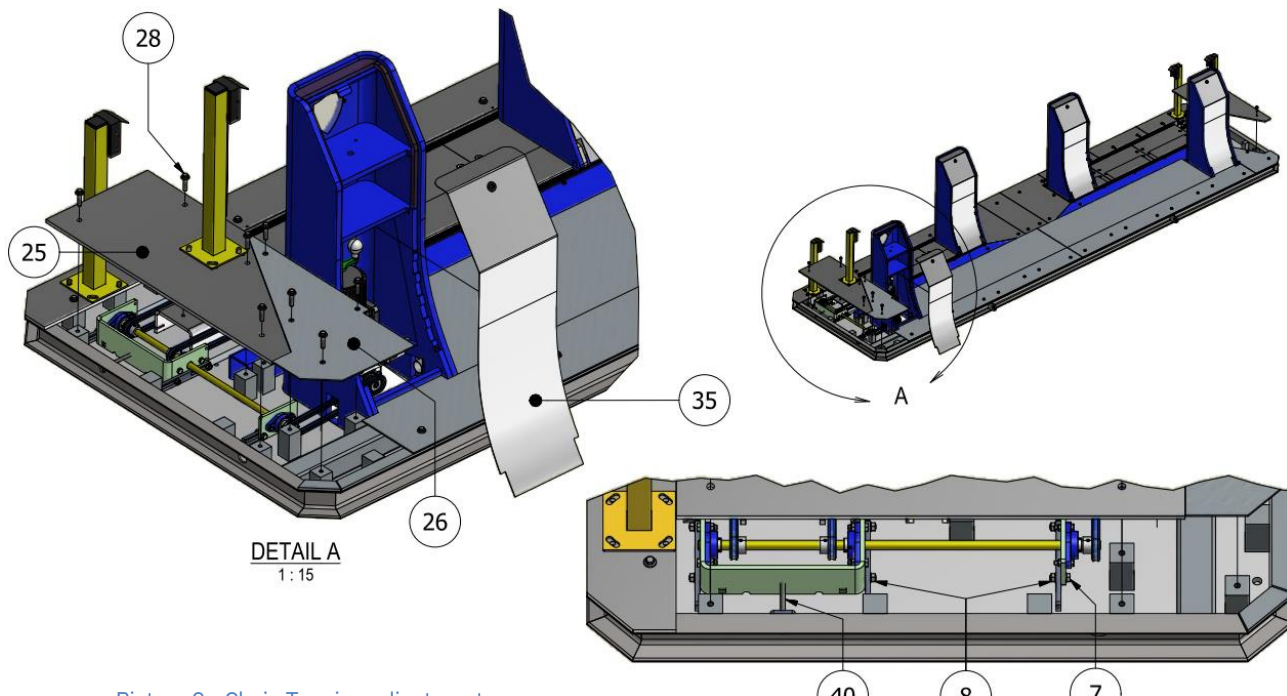

Picture 9 - Chain Tension adjustment

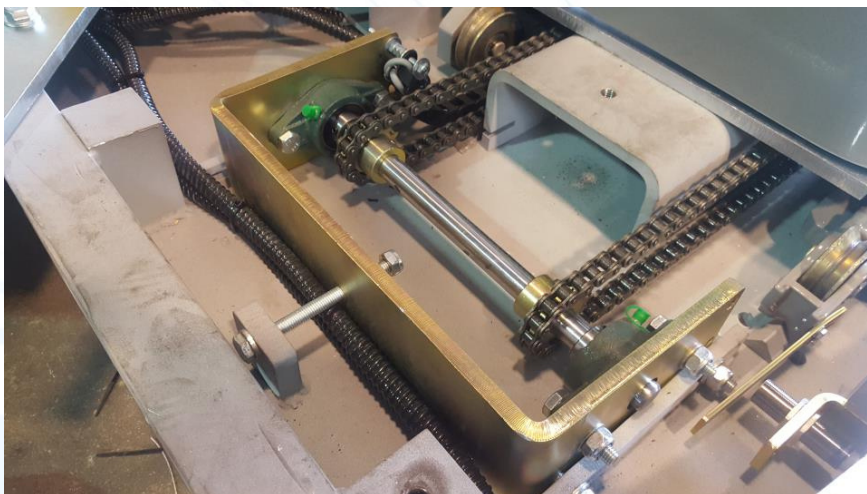

Picture 10 - Chain bracket assembly





## 6. Manual operation

The Metis can be operated both ways with a simple and easy turn of the handle. The operation will move both bollards.

In order to operate the barrier manually follow the instructions:

1. Open both of the back covers of the fixed bollards #35 according to [picture 9](#).
2. Turn down the main power switch in the control cabin.
3. Turn the handle on top of the engine clockwise or counter clockwise in order to move the bollards into open or close direction.
4. When you are done, turn the power back on and close both covers.



Picture 11 - Manual Handle





## 7. Replaceable parts list

No.	Item Description	Quantity per set	EL GO TEAM Part number
1 2	Metis bollard LED light - Green	4 4	
3	Metis bollard LED light - RED	1	
4	24V Power Supply for Bollards set.	1	AD.1100.24SPL0
5 6	12V Power Supply for Bollards LED	2 1	AD1100-12-8
7	Relays (24VDC 1P Finder)	2	466190240074
8	2 channel Safety loop detector	1	LD2-230VAC
9	Inductive Proximity Limit Switches (Normally open for down position indication)	1	XS618B1MAL5
10	Emmerson speed drive controller 1.5Kw	4	M400-024-00041A
11	Motovario three phase motor 1.5 Kw with worm gear	24	NMRL063-10PAM140/24
12	5 m Replacement Chain 1/2"	56	MOTOVARIO 08B1 1/2"
13	M10/30 Countersunk Allen Bolt for center cover plate	4	DIN 7991 M12x30
14	M12/45 Hexagon bolt for general covers plate	2	DIN 6921 M12 x 45
15	Bollard back cover with lock	32	BLG-Metis-291F-Bollard
	IR safety beam reflector/reciever		Fotocellula IR5001 PS
	M16x150 BT Anchor bolt for installation		M16x150 BT