



GAPGUARD™

FIRE DOOR ACCESSORIES





GAPGUARD™

FIRE DOOR ACCESSORIES

LIFE-SAVING MEET COST-SAVING

NGP's UL Certified 90-minute Fire Door Accessories will help you avoid the cost, labor and disruption of replacing existing doors and/or structures to achieve compliance. Whether it's an excessive gap along the perimeter of the door or a hardware revision that jeopardizes the integrity of the door itself, GapGuard™ Fire Door Accessories has a solution to get you back into compliance with ease.



A certified solution stamped to keep follow-up inspections streamlined.



Eliminate the cost and downtime of replacing existing doors and/or structures.



Simple to install, non-handed and in-field modifiable to accommodate existing hardware.



Provides options that allow for concealed installation. See the door, not the hardware.

FIRE DOOR COMPLIANCE MADE EASY!

...AND SMARTER, MORE VERSATILE, LESS VISIBLE, MORE COST-EFFECTIVE, SIMPLER TO INSTALL AND ORDER.

IT IS ALL OF THE THINGS!

GapGuard™ Fire Door Accessories provide you a one-stop, get your facility BACK INTO compliance, solution. Whether you have Excessive Gaps at the Head, Jamb, Meeting Edge and/or Bottom — or want to modify the hardware on an existing door while retaining compliance, we've got a solution to fit your needs.

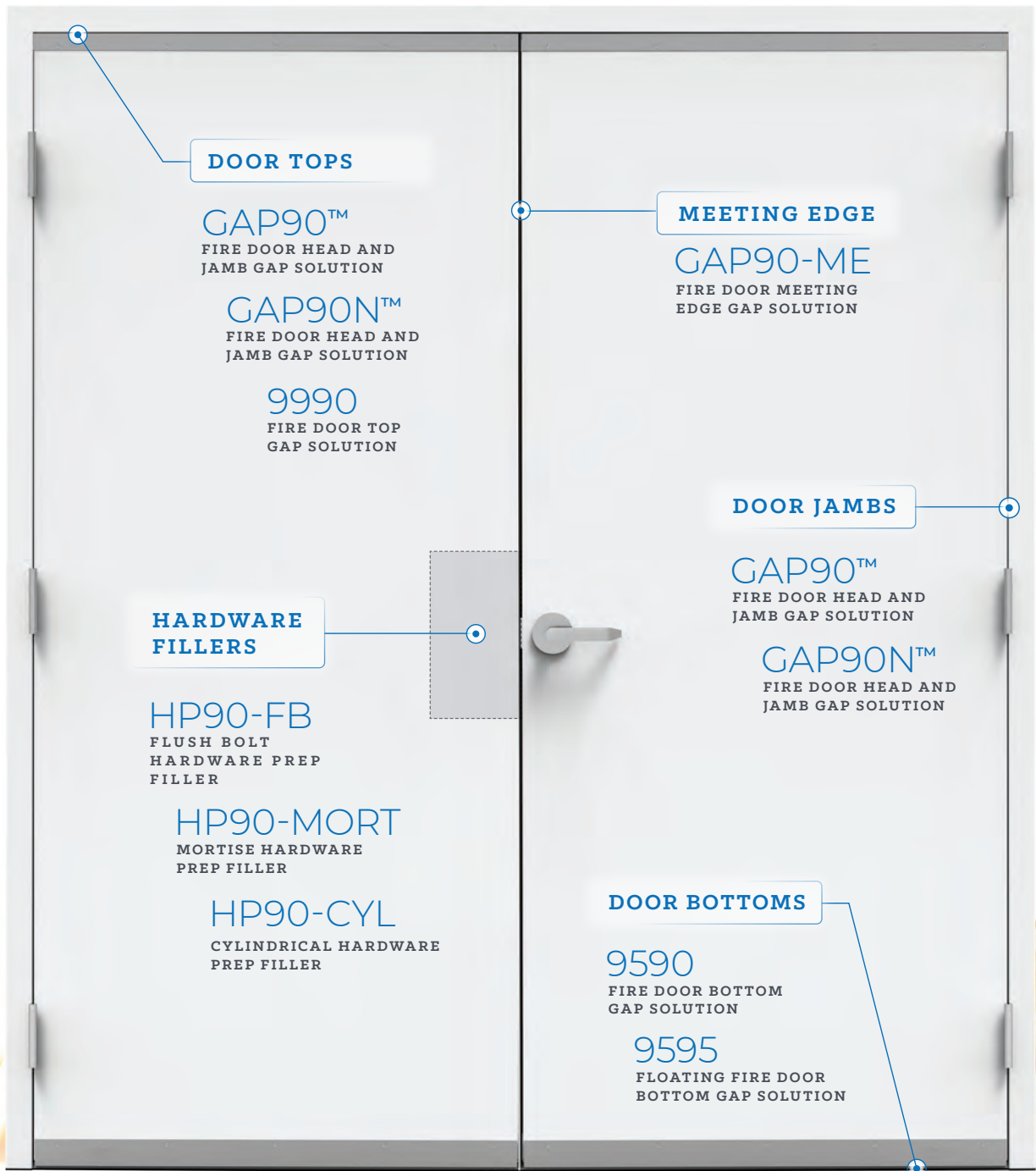



A PURSUIT OF PERFECTION:

The Product Development Team continues to innovate and test new products - a constant state of improvement.

A SMALL GAP IS A BIG DEAL

UNDERSTANDING THE PROBLEM

A Fire Door "Gap" is the space between the door and the door frame head, jamb or floor. When this space exceeds tolerances (defined by NFPA 80 and enforced by The Joint Commission), it is considered "excessive". The problem with an excessive gap is that it can allow the smoke and/or fire to pass through the opening and jeopardizes the integrity of the door. An excessive gap leads to failed code inspections that will cost your organization thousands of dollars in penalties.

Most importantly, they cause a fire door to fail, putting lives at risk!

THE GAP IS CONSIDERED "EXCESSIVE" WHEN IT IS GREATER THAN:



DOOR HEAD

WOOD: 1/8"
METAL: 1/8"
(+/- 1/16")



DOOR JAMB

WOOD: 1/8"
METAL: 1/8"
(+/- 1/16")

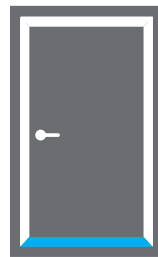

DOOR BOTTOM

WOOD: 3/4"
METAL: 3/4"

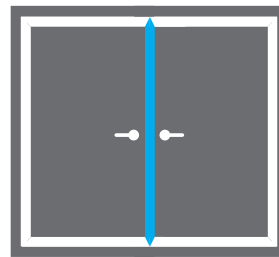

MEETING EDGE

WOOD: 1/8"
METAL: 1/8"
(+/- 1/16")

GAPGUARD™

FIRE DOOR ACCESSORIES



GAP90™
Fire Door
Head/Jamb
Gap Solution

- ▶ Gaps, up to 5/16"
- ▶ Non-Handed
- ▶ In-Field Modifiable
- ▶ Available in Dark Brown and Gray



GAP90N™
Fire Door Head/
Jamb Gap Solution
for Narrow Stops

- ▶ Gaps, up to 5/16"
- ▶ For use when the Soffit Depth is Between 1/2" and 1 3/8"
- ▶ Non-Handed
- ▶ In-Field Modifiable
- ▶ Available in Dark Brown and Gray



GAP90-ME
Fire Door Meeting
Edge Gap Solution

- ▶ Meeting Edge Gaps (Pairs of Doors), up to 3/8"
- ▶ Non-Handed
- ▶ In-Field Modifiable
- ▶ Gray Finish

 *See Installation Requirements.



9990
Fire Door Top
Gap Solution

- ▶ Door Top Gaps, up to 1/2"
- ▶ Non-Handed
- ▶ In-Field Modifiable
- ▶ Recommended for Doors with Parallel Arm Closers
- ▶ Brushed Stainless Steel Finish

GAPGUARD™

FIRE DOOR ACCESSORIES



9590

Fire Door Bottom Gap Solution

- ▶ Door Bottom Gaps, up to 1½"
- ▶ Non-Handed
- ▶ In-Field Modifiable
- ▶ Brushed Stainless Steel Finish



9595DKB

Floating Fire Door Bottom Gap Solution

- ▶ Door Bottom Gaps, up to 1¾"
- ▶ Non-Handed
- ▶ Designed to Travel Over Uneven Floors, With a Range of ¾"
- ▶ Optional L-Bracket Allows for Easy Installation
- ▶ Powder-Coated Dark Brown (DKB)



HP90-MORT

Mortise Hardware Prep Filler



HP90-FB

Flush Bolt Hardware Prep Filler



GAPGUARD™

FIRE CAULK

- ▶ Fill up to a ½" Diameter Thru-Hole
- ▶ Fully-Cured in 24 Hours
- ▶ Sandable/Paintable
- ▶ Color: Tan
- ▶ 10 Tubes per Box



**To retain UL Certification, the products indicated, must be installed using GapGuard™ Fire Caulk.*



HP90-CYL

Cylindrical Hardware Prep Filler



Includes Steel Filler Plates for use on Hollow Metal Doors

9990

FIRE DOOR TOP GAP SOLUTION



UL CERTIFIED FOR USE IN
THE US AND CANADA

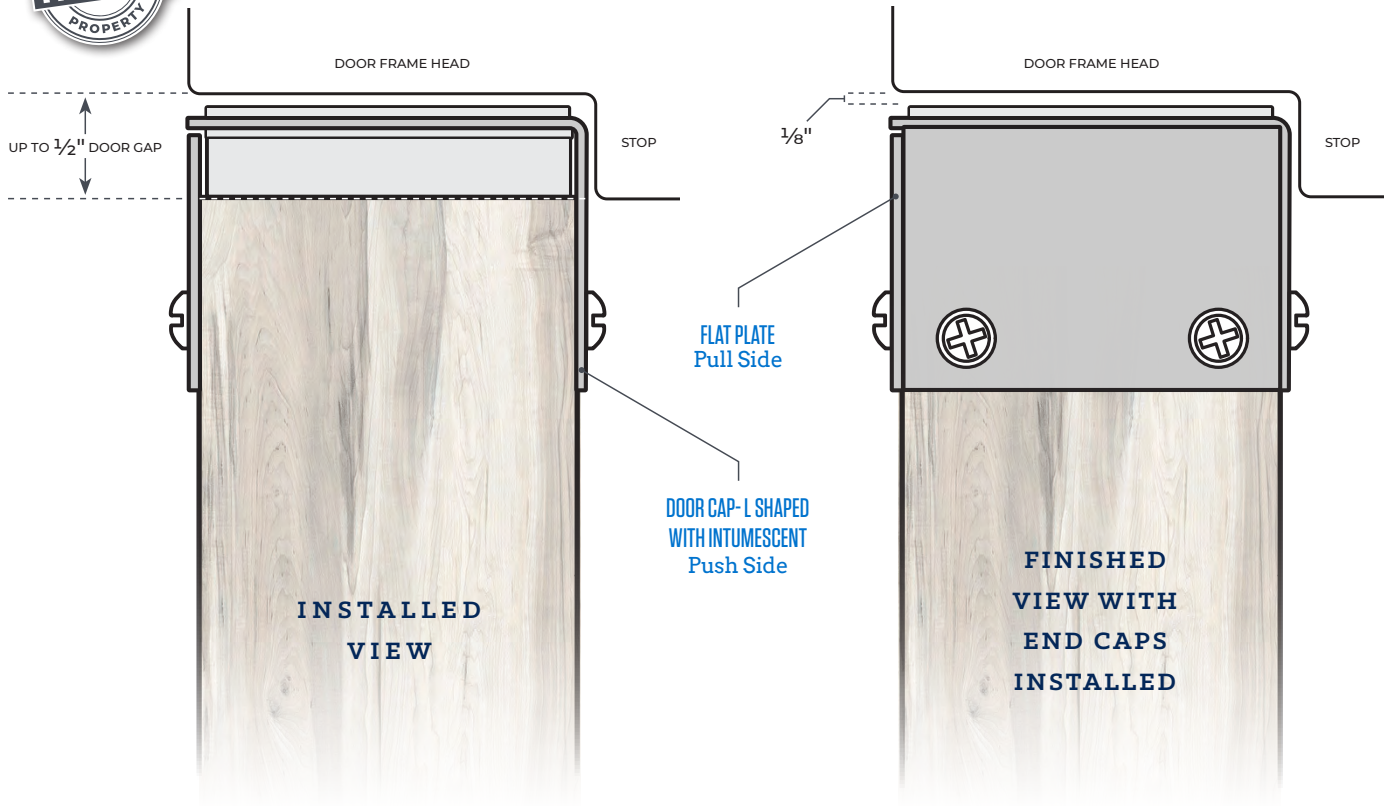

PRODUCT INFORMATION

UL Certified for Door Top Gaps — Measuring up to 1/2".

- ▶ 90-Minute Rated — for Use on UL10B and UL10C Wood or Hollow Metal Fire Doors
- ▶ Recommended for Doors with Parallel Arm Closers
- ▶ Patent Pending
- ▶ Available in 36" and 48" Lengths
- ▶ Brushed Stainless Steel
- ▶ Non-handed
- ▶ Patent No.: US 11,261,653 B2

PRODUCT CONSISTS OF:

- + #304 Brushed Stainless Steel Flat Plate - Pull Side
- + #304 Brushed Stainless Steel Intumescent Cap — Push Side
- + #304 Brushed Stainless Steel End Caps
- + #6 x 3/4" Stainless Steel SMS Furnished



POSITIVE PRESSURE TESTED
MISCELLANEOUS FIRE DOOR
ACCESSORY

GAP90™

FIRE DOOR HEAD AND JAMB GAP SOLUTION



UL CERTIFIED FOR USE IN
THE US AND CANADA

UL Certified Solution for Fire Doors with Excessive
Clearance Between Door and Frame Over $\frac{1}{8}$ ", up to $\frac{5}{16}$ ".

INSTALLED
VIEW

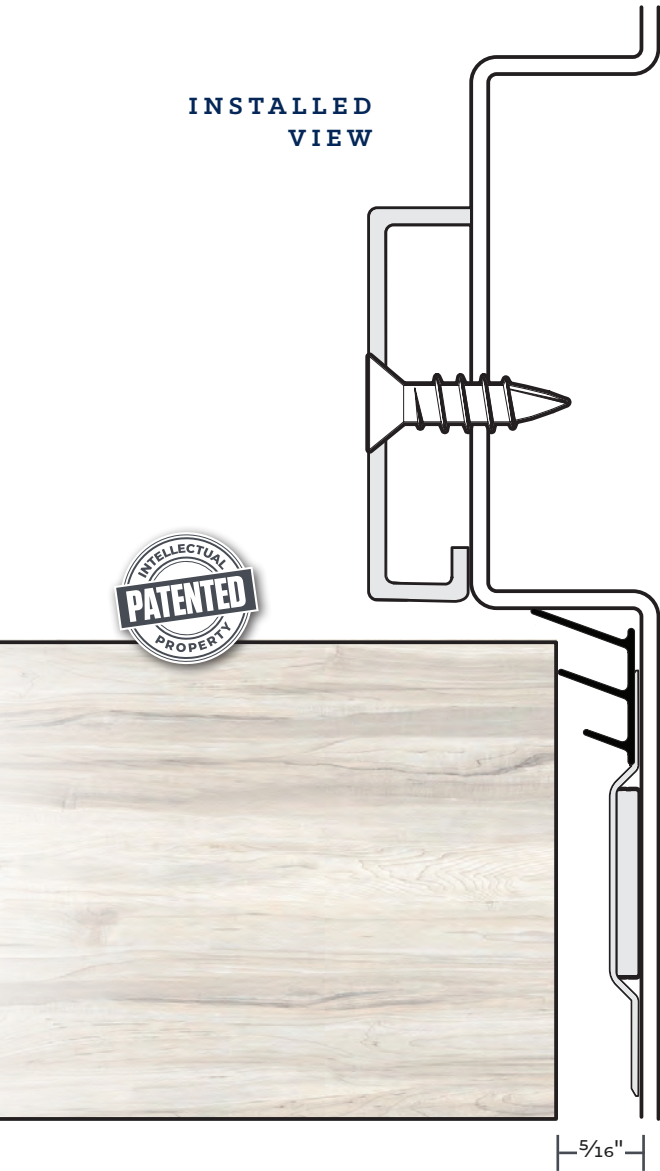

PRODUCT CONSISTS OF:

9945

Steel Stop Extender

- ◆ 16-Gauge, Gray Primer Finish
- ◆ Furnished with #10 X 1" TEK SMS
- ◆ Patent No.: US9,273,510B2
- ◆ Embossed with **UL Mark**

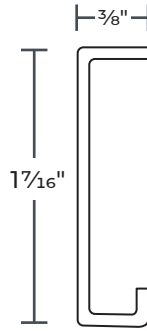

5075

Self-Adhesive Silicone Seal

5075B BROWN

5075CL CLEAR

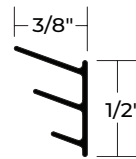

9400

NGP-Edge® Intumescent
Seal with PVC Cover

9400 GRAY

9400DKB BROWN

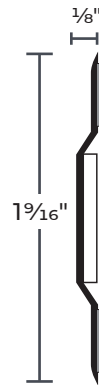

POSITIVE PRESSURE TESTED
MISCELLANEOUS FIRE DOOR
ACCESSORY

90-Minute Rated UL Certified Miscellaneous Fire Door Accessory
on UL10B and UL10C Wood or Hollow Metal Fire Doors.

An NGP Strike Shim 9275 or 9225 may also be Required for
Proper Latchbolt Engagement.

Doors with Parallel Arm Closers — Use 9990 Fire Door Top
Gap Solution.

GAP90™ INCLUDES 9945, 9400, 5075CL

GAP90DKB™ INCLUDES 9945, 9400DKB, 5075B

Available in 36", 48", 84" and 96" Lengths

GAP90N™

FIRE DOOR HEAD AND JAMB GAP SOLUTION FOR NARROW SOFFIT



UL CERTIFIED FOR USE IN THE US AND CANADA

UL Certified Solution for Fire Doors with Excessive Clearance Between Door and Frame Over $\frac{1}{8}$ " up to $\frac{5}{16}$ " and a Soffit Measuring $\frac{1}{2}$ " to $1\frac{3}{8}$ ".

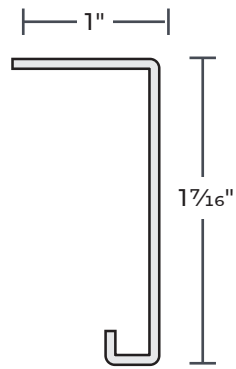

PRODUCT CONSISTS OF:

9945N

Steel Stop Extender

- ▶ 16-Gauge, Gray Primer Finish
- ▶ Furnished with #10 X 1" TEK SMS
- ▶ Patent No.: US9,273,510B2
- ▶ Embossed with **UL Mark**

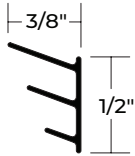

5075

Self-Adhesive Silicone Seal

5075B BROWN

5075CL CLEAR

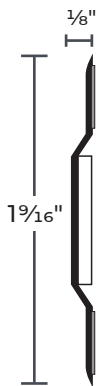

9400

NGP-Edge® Intumescent Seal with PVC Cover

9400 GRAY

9400DKB BROWN

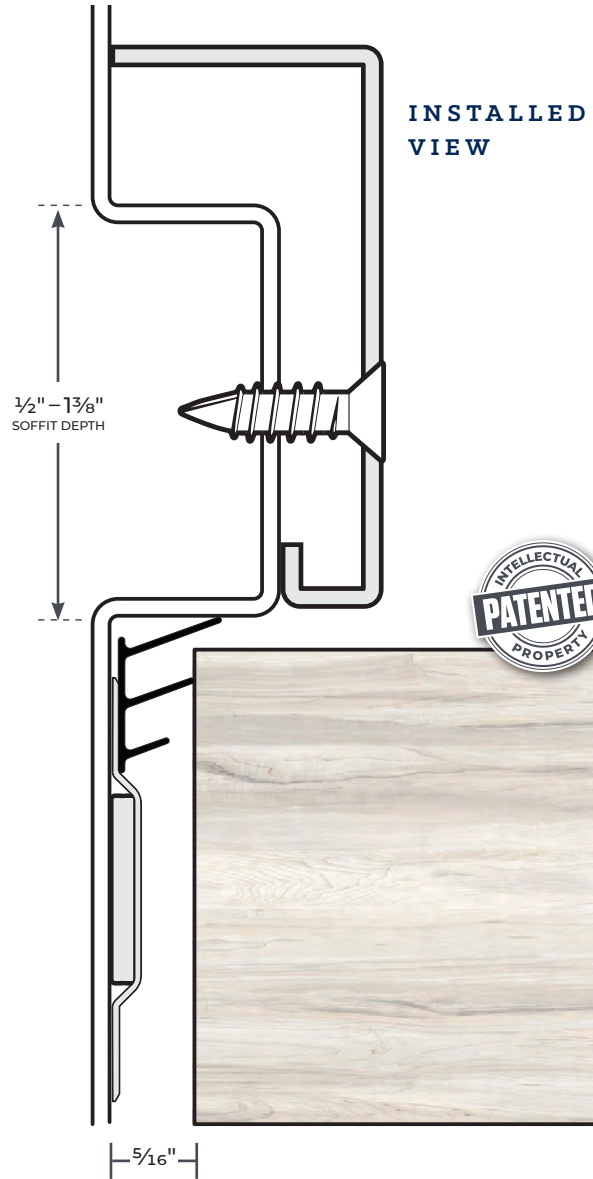

POSITIVE PRESSURE TESTED
MISCELLANEOUS FIRE DOOR
ACCESSORY

90-Minute Rated UL Certified Miscellaneous Fire Door Accessory on UL10B and UL10C Wood or Hollow Metal Fire Doors.

An NGP Strike Shim 9275 or 9225 may also be Required for Proper Latchbolt Engagement.

Doors with Parallel Arm Closers — Use 9990 Fire Door Top Gap Solution.

GAP90N™ INCLUDES 9945N, 9400, 5075CL

GAP90NDKB™ INCLUDES 9945N, 9400DKB, 5075B

Available in 36", 48", 84" and 96" Lengths

9590

FIRE DOOR BOTTOM GAP SOLUTION



UL CERTIFIED FOR USE IN
THE US AND CANADA

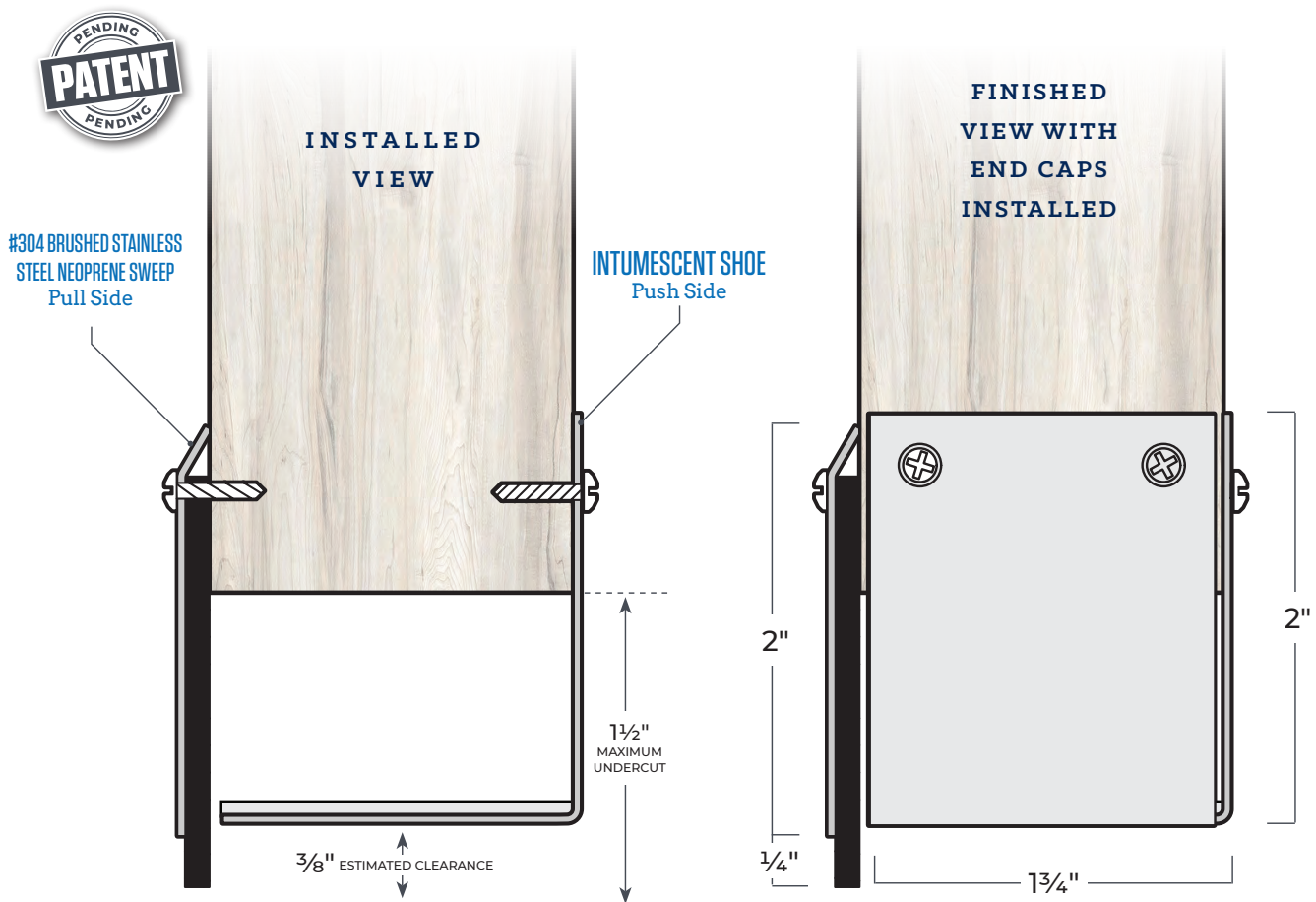

PRODUCT INFORMATION

UL Certified for Door Bottom Gaps — Measuring up to 1 1/2".

- Restricts the Passage of Smoke
- 90-Minute Rated — for use on UL10B and UL10C Wood or Hollow Metal Fire Doors
- Patent Pending
- Available in 36" and 48" Lengths
- Non-Handed

PRODUCT CONSISTS OF:

- + #304 Brushed Stainless Steel Neoprene Sweep — Pull Side
 - + #304 Brushed Stainless Steel Intumescent Shoe — Push Side
 - + #304 Brushed Stainless Steel End Caps
 - + #6 × 3/4" Stainless Steel SMS Furnished
- Brushed stainless steel
Neoprene is black*



POSITIVE PRESSURE TESTED
MISCELLANEOUS FIRE DOOR
ACCESSORY

9595DKB

FLOATING FIRE DOOR BOTTOM GAP SOLUTION



UL CERTIFIED FOR USE IN
THE US AND CANADA

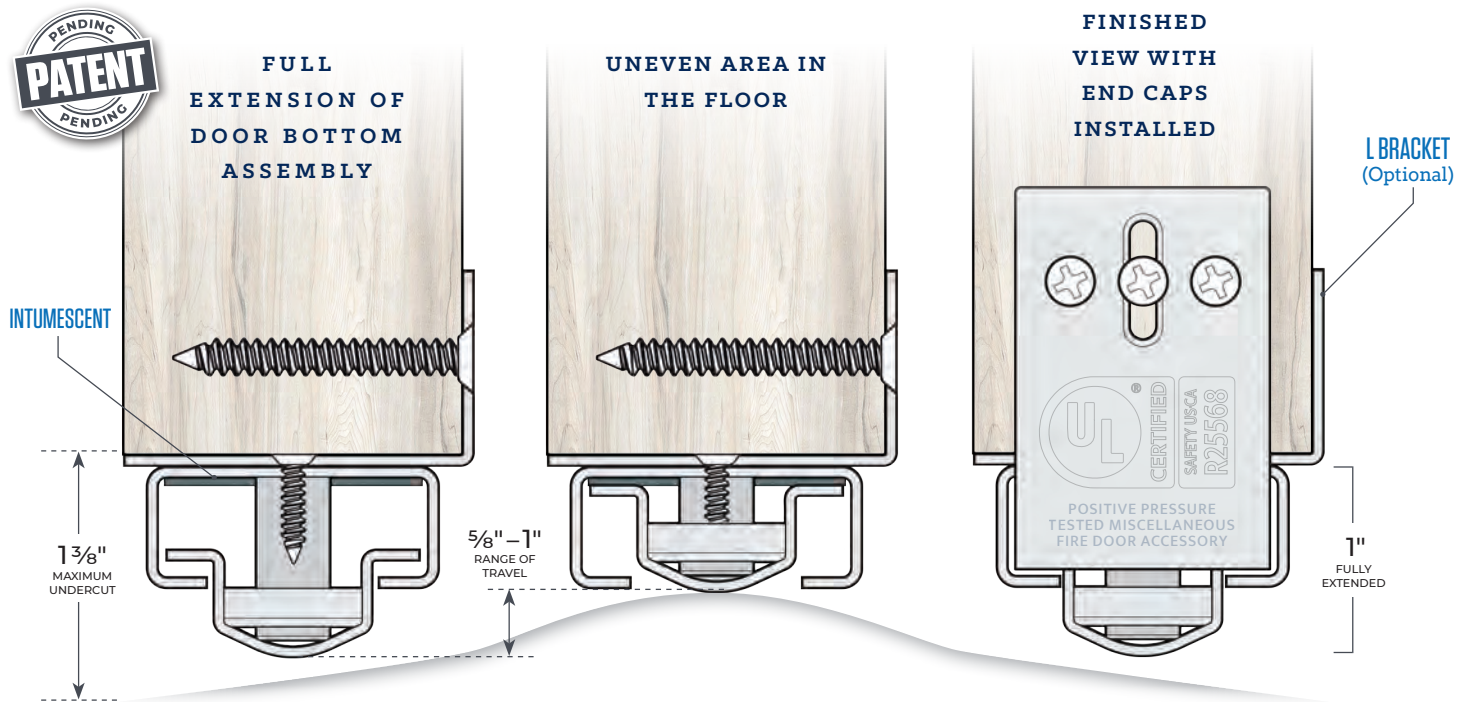

PRODUCT INFORMATION

UL Certified Solution for Fire Doors With Excessive Clearance Between the Bottom of the Door and Finished Floor, up to 1 3/8".

- ▶ Application Certified on both Hollow Metal and Wood Fire-Rated Doors, up to 90 Minutes
- ▶ Patent Pending
- ▶ Non-Handed
- ▶ L-bracket allows Installation while Door Remains on Hinges
- ▶ Field Trim to Fit: up to 1 1/2" per side, 3" total
- ▶ Designed to Travel Over Uneven Floors, with a range of 3/8"
- ▶ May be Fastened to the Underside of the Door's Bottom Rail to Minimize Visibility
- ▶ End Caps Set Height Position and Provide a Finished Look
- ▶ Sizes: 36", 42" and 48"

PRODUCT CONSISTS OF:

- + L-Bracket, 16-Gauge Steel, Embossed with UL Mark
- + Door Bottom Assembly, 18-Gauge Steel
- + End Caps, 18-Gauge Steel, Embossed With UL Mark
- + Hardware Pack
 - #10 x 1 1/2" PHPH SS SMS (DKB)
 - #8-32 x 1 3/4" PHP SS Thru-Bolt (DKB)
 - #6 x 3/8" SS TEK
 - #10 x 2" PHPH SS SMS
 - #6 x 3/4" FHPH SS SMS (DKB)

Powder Coated, DKB



POSITIVE PRESSURE TESTED
MISCELLANEOUS FIRE DOOR
ACCESSORY

GAP90-ME

FIRE DOOR MEETING EDGE GAP SOLUTION



UL CERTIFIED FOR USE IN
THE US AND CANADA

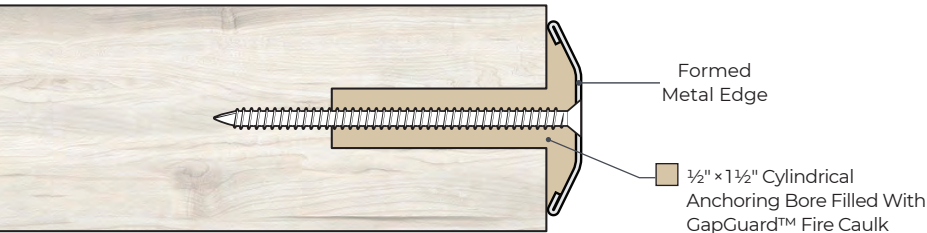

WOOD DOOR INSTALLATION SHOWN

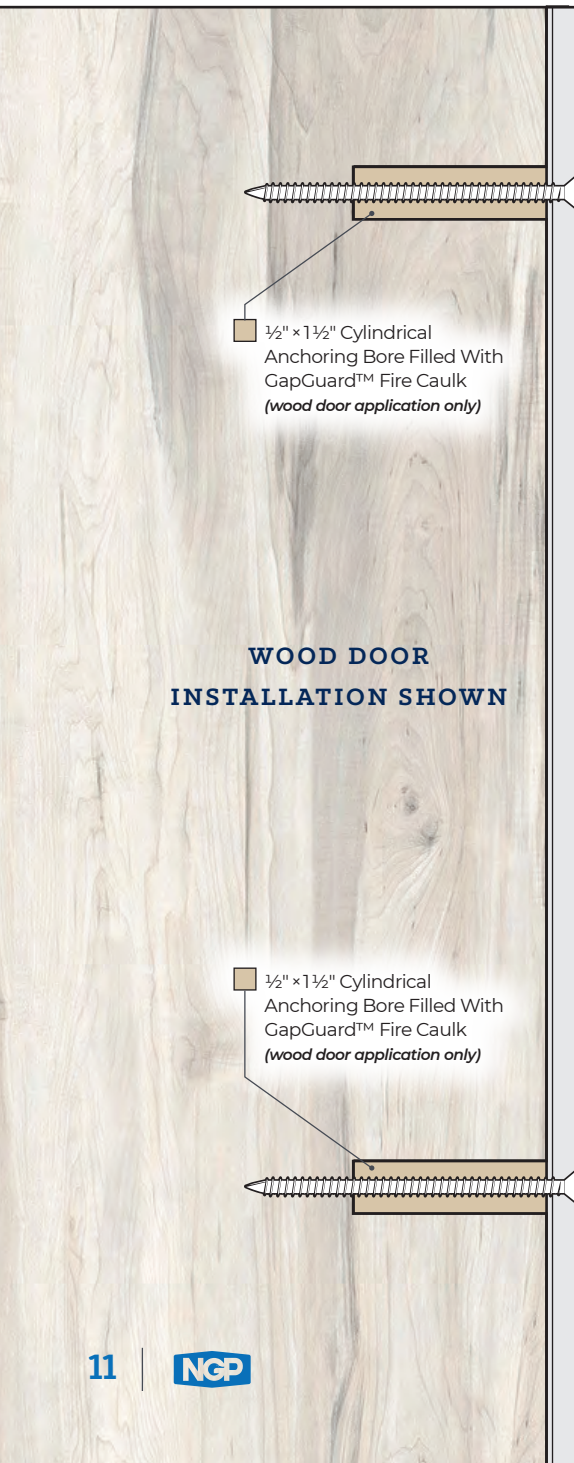

UL Certified Solution for Fire Doors with Excessive Clearance Between the Meeting Edges of a Pair of Doors, up to ⅜".

- Application Certified on both Hollow Metal and Wood Fire-Rated Doors, up to 90-Minute
- Patent Pending
- Non-Handed
- Certified for use on Doors with Surface/ Concealed Vertical Rod Exit Devices or Manual/Automatic Flush Bolts
(see *Installation Instructions*)
- Can be Installed with the Door on the Hinges
- Can be Field-Modified to Match-Fit Varying Width Gap Along Height of the Door (see *installation instructions*)

PRODUCT CONSISTS OF:

- + Formed Metal Edge, 20-Gauge Steel, Embossed With UL Mark
- + Powder Coated, Primer Gray
- + Hardware Pack
 - #10 × ¾" FHPH SS TEK
 - #10 × 2½" FHPH SS SMS
- + GapGuard™ Fire Caulk
(see *Installation Instructions*)



POSITIVE PRESSURE TESTED
MISCELLANEOUS FIRE DOOR
ACCESSORY



SPECIAL NOTES:

- 90-Minute Rated UL Certified Miscellaneous Fire Door Accessory on UL10B and UL10C Wood or Hollow Metal Fire Doors.
- An NGP Strike Shim 9275 or 9225 may also be Required for Proper Latchbolt Engagement.
- Certified for On-site Modifications Around Strike Location.
- If Fire Pins are used, it is Recommended to Apply Metal Edge to Door with Fire Pin Receiver, Ensuring Receiver is Flush with Metal Edge.
- To Retain UL Certification, the Gap90-ME must be Installed using GapGuard™ Fire Caulk.

HP90-CYL

CYLINDRICAL HARDWARE PREP FILLER



UL Certified Solution for Fire Doors When Either Removing Existing Hardware and/or Using a New Hardware Type Over Existing Hardware Prep's.

UL CERTIFIED FOR USE IN THE US AND CANADA

- Application Certified on both Hollow Metal and Wood Fire Rated Doors, up to 90 Minutes
- Patent Pending
- Certified for Filling Cylindrical Lockset Cavities

WOOD DOOR: INSTALLED VIEW



■ GapGuard™ Fire Caulk Fill



STEEL DOOR: INSTALLED VIEW

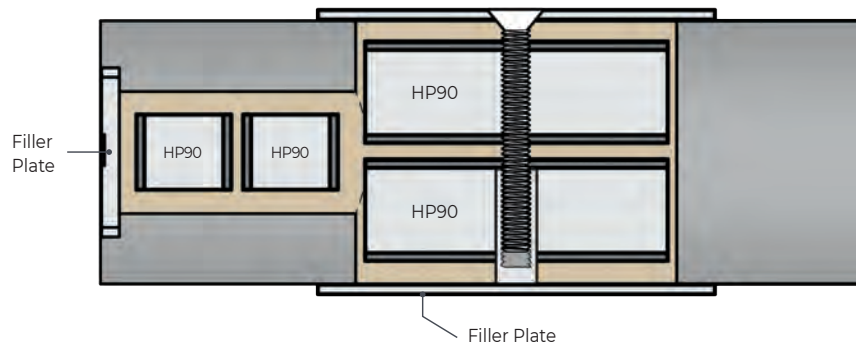

■ GapGuard™ Fire Caulk Fill

PRODUCT CONSISTS OF:

- + Fire-Rated Panels:
 - HP90 – 2.0
 - HP90 – 1.0
 - HP90 – 0.5
- + Steel Filler Plates, Powder Coated, Primer Gray, Embossed with UL Mark
 - HP90-RDCP, Filler Plate
 - HP90-CEF1000, Edge Filler Plate
 - HP90-SF2750, Strike Filler Plate
 - HP90-SF4875, Strike Filler Plate
- + Hardware Pack
 - #10-32 x 1 3/4" FHPH SS Machine Screw
 - #8 x 3/4" FHPH SS Combo Screw
 - #12 x 1" FHPH SS Combo Screw
 - #8 x 3/4" FHPH SS SMS
 - #12 x 1" FHPH SS SMS
- + GapGuard™ Fire Caulk
(see *Installation Instructions*)



POSITIVE PRESSURE TESTED
MISCELLANEOUS FIRE DOOR
ACCESSORY



SPECIAL NOTES:

- 90-Minute Rated UL Certified Miscellaneous Fire Door Accessory on UL10B and UL10C Wood or Hollow Metal Fire Doors

• To Retain UL Certification, the HP90-MORT must be Installed using GapGuard™ Fire Caulk

HP90-FB

FLUSH BOLT HARDWARE PREP FILLER



UL CERTIFIED FOR USE IN
THE US AND CANADA



UL Certified Solution for Fire Doors When Either Removing Existing Hardware and/or Using a New Hardware Type Over Existing Hardware Prep's.

PRODUCT INFORMATION

- Application Certified On Both Hollow Metal And Wood Fire-Rated Doors Up To 90-Minutes
- Patent Pending
- Certified for Filling Manual or Automatic Flush Bolt Cavities

PRODUCT CONSISTS OF:

- + HP90 – 2" x 6" Rectangular Fire-Rated Panel
- + HP90 – 0.5 Cylindrical Fire-Rated Panel
- + Steel Filler Plates: *(Powder Coated Primer Gray, Embossed With UL Mark)*
 - HP90-FBE6750, Edge Filler Plate
 - HP90-FBE8500, Edge Filler Plate
 - HP90-FBL2000, Latch Bolt Filler Plate
 - HP90-FBL2500, Latch Bolt Filler Plate
 - HP90-FBL3875, Latch Bolt Filler Plate
 - HP90-SF2250, Strike Filler Plate
- + Hardware Pack
 - #10-32 x 1-3/4" FHPH SS machine screw
 - #8 x 3/4" FHPH SS combo screw
 - #12 x 1" FHPH SS combo screw
 - #8 x 3/4" FHPH SS SMS
 - #12 x 1" FHPH SS SMS
- + GapGuard™ Fire Caulk *(see Installation Instructions)*



POSITIVE PRESSURE TESTED
MISCELLANEOUS FIRE DOOR
ACCESSORY



SPECIAL NOTES:

- 90-Minute Rated UL Certified Miscellaneous Fire Door Accessory on UL10B and UL10C Wood or Hollow Metal Fire Doors
- To Retain UL Certification, the HP90-MORT must be Installed using GapGuard™ Fire Caulk

HP90-MORT

MORTISE HARDWARE PREP FILLER



UL CERTIFIED FOR USE IN
THE US AND CANADA

UL Certified Solution for Fire Doors When Either Removing Existing Hardware and/or Using a New Hardware Type Over Existing Hardware Prep's.

PRODUCT INFORMATION

- ▶ Application Certified on Both Hollow Metal and Wood Fire-Rated Doors – up to 90-Minute
- ▶ Patent Pending
- ▶ Certified for Filling Mortise Lockset Cavities

PRODUCT CONSISTS OF:

- + HP90 – 4" x 6" Fire-Rated Panel
- + Steel Filler Plates: *(Powder Coated Primer Gray, Embossed With UL Mark)*
 - HP90-MEF1258, Edge Filler Plate
 - HP90-SF4875, Strike Filler Plate
- + Hardware Pack
 - #10-32 x 1-3/4" FHPH SS machine screw
 - #8 x 3/4" FHPH SS combo screw
 - #12 x 1" FHPH SS combo screw
 - #8 x 3/4" FHPH SS SMS
 - #12 x 1" FHPH SS SMS
- + GapGuard™ Fire Caulk
(see Installation Instructions)



POSITIVE PRESSURE TESTED
MISCELLANEOUS FIRE DOOR
ACCESSORY



SPECIAL NOTES:

- 90-Minute Rated UL Certified Miscellaneous Fire Door Accessory on UL10B and UL10C Wood or Hollow Metal Fire Doors
- To Retain UL Certification, the HP90-MORT must be Installed using GapGuard™ Fire Caulk

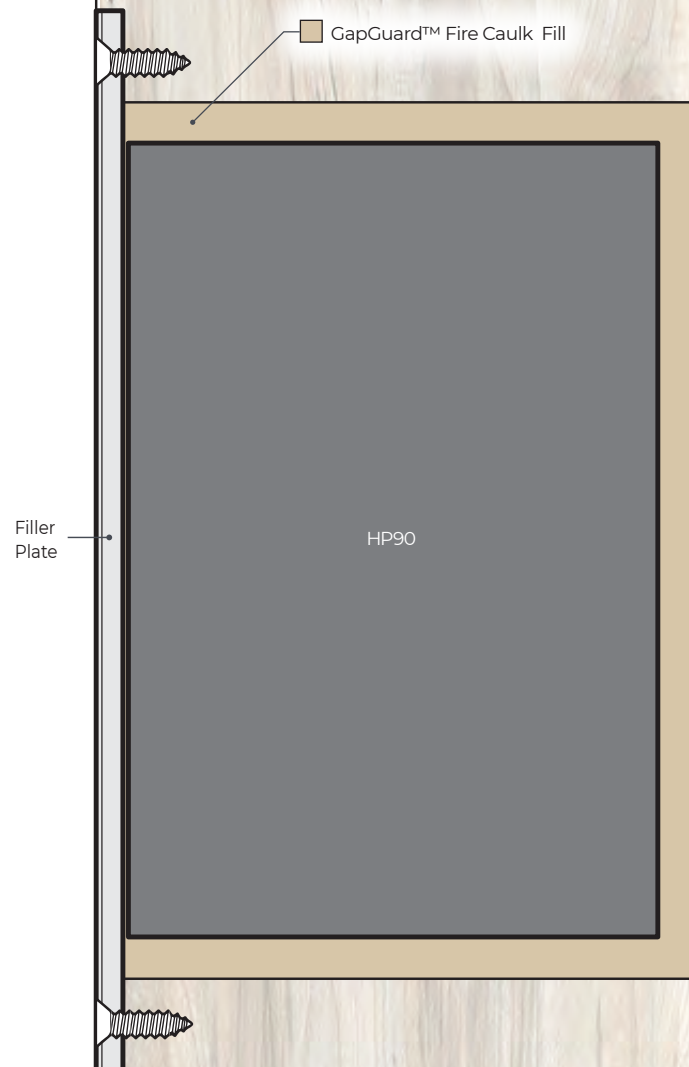

**WOOD DOOR
INSTALLATION
SHOWN**

HP90

HARDWARE PREP FILLERS



UL CERTIFIED FOR USE IN THE US AND CANADA

UL Certified Solution for Fire Doors When Either Removing Existing Hardware and/or Using a New Hardware Type Over Existing Hardware Prep's.



- Application Certified on both Hollow Metal and Wood Fire-Rated Doors, up to 90 Minutes
- Certified for Use in Combination With Gap Guard™ Fire Caulk to Fill Thru-Holes Between ½" Diameter and 2 ½" Diameter

PART NO.	DESCRIPTION
HP90 - 0.5	½" Diameter Hardware Prep Filler (10 Pack)
HP90 - 1.0	1" Diameter Hardware Prep Filler (10 Pack)
HP90 - 1.5	1½" Diameter Hardware Prep Filler (10 Pack)
HP90 - 2.0	2" Diameter Hardware Prep Filler (10 Pack)



POSITIVE PRESSURE TESTED MISCELLANEOUS FIRE DOOR ACCESSORY

GAPGUARD™ FIRE CAULK



UL CERTIFIED FOR USE IN THE US AND CANADA

UL Certified Solution for Fire Doors and Frames to Seal Thru-Holes as well as in Combination With Other Hardware Prep Filler Solutions.

PRODUCT INFORMATION

- Application Certified on both Hollow Metal and Wood Fire-Rated Doors, up to 90-Minutes
- Can be Used to Fill up to a ½" Diameter Thru-Hole
- Fully Cured in 24 Hours
- Can be Sanded and Painted after Full Cure
- Indoor Use Only
- Shelf Life is 12 Months
- 10.3 fl. oz. Cartridge
- 10 Tubes per Box

Color: Tan



POSITIVE PRESSURE TESTED MISCELLANEOUS FIRE DOOR ACCESSORY

GAPGUARD™ STRIKES

90 MINUTE STRIKE SHIMS



UL Certified Miscellaneous GAPGUARD™ for Excessive Door and Frame Clearances, Measuring up to 5/16".

UL CERTIFIED FOR USE IN THE US AND CANADA

9275 - Fits 4 7/8" 'ASA' Strike Plate

9225 - Fits 2 3/4" 'T' Strike Plate

UL Certified Miscellaneous Fire Door Accessory for Excessive Door and Frame Clearances, Measuring Up To 5/16"

Required for Proper Latchbolt Engagement

90-Minute Rated UL10B and UL10C Wood or Hollow Metal Fire Doors

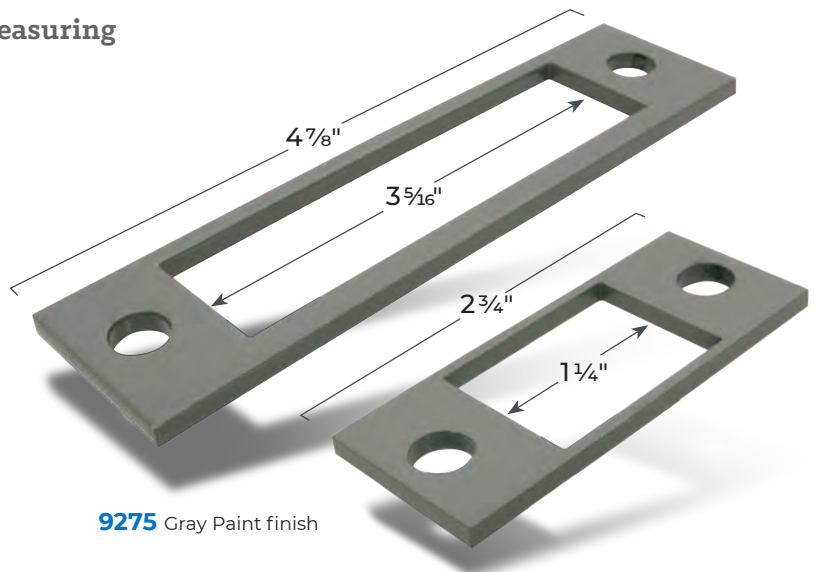

9275 Gray Paint finish

9225 Gray, Paint finish



POSITIVE PRESSURE TESTED
MISCELLANEOUS FIRE DOOR
ACCESSORY

GAPGUARD™ THRU-BOLTS

90 MINUTE THRU-BOLTS



- ▶ Fits 1 3/4" to 2" Thick Doors
- ▶ Zinc-Plated Steel Sleeve with Machine Screws
- ▶ Meets Requirements of NFPA 80 for Use on Fire Doors
- ▶ Use to Fill Holes in Wood or Steel Fire Doors to Protect Label Compliance
- ▶ Available in Boxes of Twenty

UL CERTIFIED FOR USE IN THE US AND CANADA



POSITIVE PRESSURE TESTED
MISCELLANEOUS FIRE DOOR
ACCESSORY

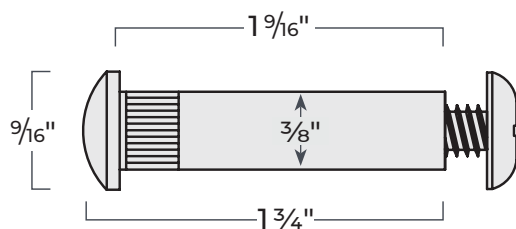

FDTB 3/8"
Thread Size 3/4-20

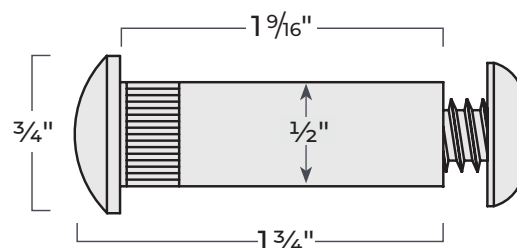

FDTB 1/2"
Thread Size 5/16-18

STEEL HINGE SHIMS



UL CERTIFIED FOR USE IN THE US AND CANADA

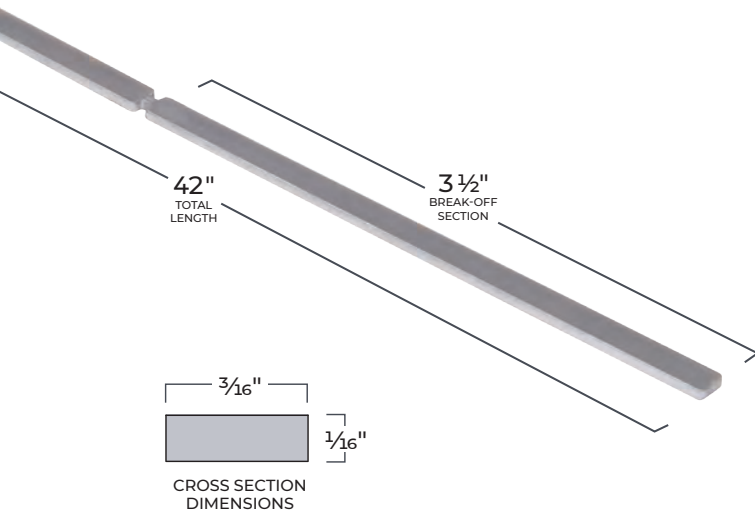

HS-1

- ▶ Use to Shim Hinges to Achieve Required Clearances Between Door and Frame
- ▶ Dual Purpose Shim
Use Full 42" Length for Continuous Hinges
Break-Off 3 1/2" Sections for Butt Hinges
- ▶ Steel Fire-Rated Shims
- ▶ Pressure Sensitive Adhesive Pads Included for Holding in Place During Installation
- ▶ Removable, Re-Stickable, and Stackable
- ▶ Available in Boxes of Ten



POSITIVE PRESSURE TESTED
MISCELLANEOUS FIRE DOOR
ACCESSORY

9945EC & 9945NEC

END CAPS

UL CERTIFIED FOR USE IN THE US AND CANADA

For Use on GAP90 and GAP90N Steel Stop Extender Components 9945 and 9945N.

- ▶ Use to Cap the Exposed Open End of the Steel Stop Extender When Cut at Rim Panic Strike or Other Hardware
- ▶ Sold in 10 Packs
- ▶ Sold Flat, Tabs Must be Formed Prior to Use



POSITIVE PRESSURE TESTED
MISCELLANEOUS FIRE DOOR
ACCESSORY

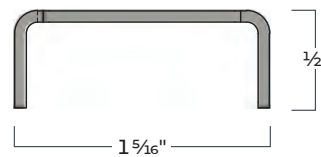

9945EC

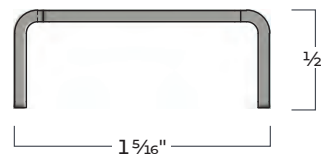

9945NEC



FREQUENTLY ASKED QUESTIONS

GAPGUARD™ GENERAL QUESTIONS

GAPS—WHAT DOES THE CODE SAY?

NFPA 80 (the code standard for fire doors) states that fire doors must be inspected on an annual basis. Maximum allowable perimeter gap is $\frac{3}{8}$ " for wood doors, $\frac{3}{8}$ " +/- $\frac{1}{16}$ " for metal doors. Maximum allowable door bottom gap is $\frac{3}{4}$ ". Gaps that exceed these maximum allowable tolerances result in a non-compliant fire door that needs to be repaired.

GAPS—PERIMETER VS. DOOR BOTTOM?

Perimeter gaps in doors are the distance between the edge of the door and door frame as measured on the pull side of the opening. Door bottom gaps are the distance between the bottom of the door and the finish floor.

GAPS—WHY ARE THEY IMPORTANT?

Proper gap tolerances ensure that the door will perform as it is intended. Gaps that are outside of tolerance can lead to compromised fire door integrity in a fire situation as well as not allowing the fire door latching mechanism to engage fully as it is required to do by code.

REPAIRS—WHAT DOES THE CODE REQUIRE?

Separate from the FDI Inspection Log; a Maintenance Log is required to be kept with record of repairs to each door. It should include specific product information and certification for products applied that solve issues like excessive gaps.

UL MARK—WHAT DOES IT INCLUDE?

The 'official' **UL Mark** is the UL Shield & Category ID – POSITIVE PRESSURE TESTED MISCELLANEOUS FIRE DOOR ACCESSORY. For information regarding the special nature of GapGuard™ applications including all required components refer to the installation instructions.

UL MARK—WHERE IS THE OFFICIAL MARK & COMPREHENSIVE INFO?

GapGuard™ installation instructions included in each set contain the 'official' **UL Mark**, category ID, and comprehensive information regarding application and installation of all components. Installation Instructions are also available on ngp.com in 8 ½" x 11" PDF format.

GAP90™ FIRE DOOR HEAD/JAMB GAP SOLUTION

WHERE IS THE GAP90™ SOLUTION REQUIRED?

GAP90™ is only needed in the areas where gaps exceed compliance. It is often aesthetically desirable to run the Steel Stop Extender (9945) full length of head or jamb, while applying intumescent (9400/9400DKB) and TPE Seal (5075CL/5075B) where the gap is excessive.

HOW DOES GAP90™ CLOSE THE GAP?

With GAP90™ installed the excessive gap will still be visible. GAP90™ is tested and certified for use on doors WITH excessive gap as it allows them to successfully pass up to a 90 minute UL10C positive pressure fire endurance test and required hose stream test.

HOW TO APPLY GAP90™ TO DOOR FRAMES WITH HOSPITAL STOPS?

The intention of the hospital stop is to allow for easy cleaning of the area where the frame meets the floor. The Steel Stop Extender (9945) should stop at the miter for the same reasons as the actual hospital stop. The Intumescent component (9400/9400DKB) should continue to the bottom of the frame. Optionally, the TPE Seal (5075CL/5075B) may stop at the miter or continue to the bottom of the frame.

HOW IS THE GAP90™ DIFFERENT THAN THE GAP90N™?

The Steel Stop Extender (9945) design is different between GAP90™ and GAP90N™. The flat side of the stop extender measures $\frac{3}{8}$ " and is designed to land on the soffit.

WHAT SOFFIT DEPTH DOES THE GAP90™ ACCOMMODATE?

The Steel Stop Extender (9945) is designed to accommodate a soffit depth greater than 1½". For soffit depths less than 1½", GAP90N™ is preferred.

CAN I CLOSE THE OPEN ENDS OF THE STOP EXTENDER (IF EXPOSED)?

End caps are available to provide a smooth finish when the end of the Steel Stop Extender is open, such as when modifying for hardware or at the frame header for double egress doors.

HOW DO I USE THE END CAPS?

End caps are provided in the flat form, with tabs that need to be bent at 90° before inserting into the open end of the Steel Stop Extender (9945).

FREQUENTLY ASKED QUESTIONS *(continued)*

GAP90™ FIRE DOOR HEAD/ JAMB GAP SOLUTION *(continued)*

CAN I PAINT THE STOP EXTENDER?

Yes, the Steel Stop Extender (9945) can be finish coated with like materials as the original door.

IS THE STEEL STOP EXTENDER (9945) MARKED WITH THE UL STAMP?

Yes, the official **UL Mark** is the UL Shield & Category ID – Positive Pressure Tested Miscellaneous Fire Door Accessory.

IS THE STEEL STOP EXTENDER (9945) HANDED?

No, the Steel Stop Extender (9945) is symmetrical.

CAN THE GAP90™ BE MODIFIED?

Yes. GAP90™ may be prepped to accommodate existing door hardware such as on-site modifications around rim exit device strikes.

GAP90N™ FIRE DOOR HEAD/ JAMB GAP SOLUTION FOR NARROW STOPS

WHERE IS THE GAP90N™ SOLUTION REQUIRED?

GAP90N™ is only needed in the areas where gaps exceed compliance. It is often aesthetically desirable to run the Steel Stop Extender (9945N) full length of head or jamb, while applying intumescent (9400/9400DKB) and TPE Seal (5075CL/5075B) where the gap is excessive.

HOW DOES GAP90N™ CLOSE THE GAP?

With GAP90N™ installed – excessive gap will still be visible. GAP90N™ is tested and certified for use on doors WITH excessive gap as it allows them to successfully pass up to a 90 minute UL10C positive pressure fire endurance test and required hose stream test.

HOW TO APPLY GAP90N™ TO DOOR FRAMES WITH HOSPITAL STOPS?

The intention of the hospital stop is to allow for easy cleaning of the area where the frame meets the floor. The Steel Stop Extender (9945N) should stop at the miter for the same reasons as the actual hospital stop. The Intumescent component (9400/9400DKB) should continue to the bottom of the frame. Optionally, the TPE Seal (5075CL/5075B) may stop at the miter or continue to the bottom of the frame.

HOW IS THIS DIFFERENT THAN THE GAP90N™?

The Steel Stop Extender (9945N) design is different for the GAP90N™. The flat side of the Steel Stop Extender (9945N) has been extended from $\frac{3}{8}$ " to 1", which is designed to land on the rabbet.

GAP90N™ FIRE DOOR HEAD/ JAMB GAP SOLUTION FOR NARROW STOPS *(continued)*

WHAT SOFFIT DEPTH DOES THE GAP90N™ ACCOMMODATE?

The Steel Stop Extender (9945N) is designed to accommodate a soffit depth of $\frac{1}{2}$ " – $1\frac{3}{8}$ ". For soffit depths greater than $1\frac{3}{8}$ ", GAP90™ is preferred.

WHAT IF THE STOP HEIGHT IS LESS THAN 5/8"?

The 1" leg can be cut down as needed to accommodate varying stop heights.

CAN I CLOSE THE OPEN ENDS OF THE STOP EXTENDER (IF EXPOSED)?

End caps are available to provide a smooth finish when the end of the Steel Stop Extender (9945N) is open, such as when modifying for hardware or at the frame header for double egress doors.

HOW DO I USE THE END CAPS?

End caps are provided in the flat form, with tabs that need to be bent at 90° before inserting into the open end of the Steel Stop Extender (9945N). For end caps used on the GAP90N™, where necessary the end cap will need to be cut to fit the size of the open end of the Steel Stop Extender (9945N).

CAN I PAINT THE STEEL STOP EXTENDER (9945N)?

Yes, the Steel Stop Extender (9945N) can be finish coated with like materials as the original door.

IS THE STEEL STOP EXTENDER (9945N) MARKED WITH THE UL STAMP?

Yes, the official **UL Mark** is the UL Shield & Category ID – Positive Pressure Tested Miscellaneous Fire Door Accessory.

IS THE STEEL STOP EXTENDER (9945N) HANDED?

No, the Steel Stop Extender (9945N) is symmetrical.

CAN THE GAP90N™ BE MODIFIED?

Yes. GAP90N™ may be prepped to accommodate existing door hardware such as on-site modifications around rim exit device strikes.

FREQUENTLY ASKED QUESTIONS *(continued)*

9990 FIRE DOOR TOP GAP SOLUTION

IS THE 9990 DOOR TOP MARKED WITH THE UL STAMP?

Yes, the official **UL Mark** is the UL Shield & Category ID – Positive Pressure Tested Miscellaneous Fire Door Accessory.

CAN THE 9990 DOOR TOP BE MODIFIED?

Yes. The 9990 Door Top may be prepped to accommodate existing door hardware such as on-site modifications around concealed vertical rod exit device latches or automatic flush bolts.

TO WHICH SIDE OF THE DOOR IS THE L-SHAPED COMPONENT ATTACHED?

The push side. The L-shaped component is on the stop face of the door.

ARE THE END CAPS REQUIRED TO MAINTAIN UL CERTIFICATION?

The end caps are used to provide a clean, finished appearance.

IS THE 9990 DOOR TOP HANDED?

No, the design is symmetrical.

9590 FIRE DOOR BOTTOM GAP SOLUTION

IS THE 9590 DOOR BOTTOM MARKED WITH THE UL STAMP?

Yes, the official **UL Mark** is the UL Shield & Category ID – Positive Pressure Tested Miscellaneous Fire Door Accessory.

CAN THE 9590 DOOR BOTTOM BE MODIFIED?

Yes. The 9590 Door Bottom may be prepped to accommodate existing door hardware such as on-site modifications around concealed vertical rod exit device latches or automatic flush bolts.

IS THE ATTACHMENT METHOD THE SAME FOR BOTH WOOD AND HOLLOW METAL DOORS?

Yes.

DO I HAVE TO REMOVE THE DOOR TO INSTALL THE 9590 DOOR BOTTOM?

No. The 9590 door bottom can be installed while the door is on the hinges.

CAN I TRIM THE 9590 DOOR BOTTOM?

Yes. The 9590 door bottom can be trimmed up to match the width of the door.

9590 FIRE DOOR BOTTOM GAP SOLUTION *(continued)*

ARE THE END CAPS REQUIRED TO MAINTAIN UL CERTIFICATION?

The end caps are used to provide a clean, finished appearance.

TO WHICH SIDE OF THE DOOR IS THE L-SHAPED COMPONENT ATTACHED?

The push side. The L-shaped component is on the stop face of the door.

IS THE 9590 DOOR BOTTOM HANDED?

No, the design is symmetrical.

9595 FLOATING FIRE DOOR BOTTOM GAP SOLUTION

IS THE ATTACHMENT METHOD THE SAME FOR BOTH WOOD AND HOLLOW METAL DOORS?

There are two options to install the 9595 door bottom. For hollow metal doors, the L-bracket is used with thru-bolts. For wood doors, the L-bracket and either thru-bolts or wood screws can be used. Additionally for wood doors, the 9595 door bottom can be installed directly to the bottom face of the bottom rail, not using the L-bracket.

DO I HAVE TO USE THE L-BRACKET?

The L-bracket is required on standard hollow metal doors and is optional for custom hollow metal doors and wood doors which have a flat bottom rail for attachment.

WHEN USING THE L-BRACKET, TO WHICH SIDE OF THE DOOR IS THE 9595 DOOR BOTTOM ATTACHED?

The 9595 door bottom can be installed to either side of the door. As reference, installation to the pull side (or hinge face) of the door will hide the L-bracket from visibility when the door is held in the open position.

HOW DO I KNOW WHICH SIDE OF THE L-BRACKET TO ATTACH TO THE DOOR?

The shorter of the two legs of the L-bracket measures 1" and is used to attach to the face of the door. This leg contains the **UL Mark**.

HOW DO I KNOW WHICH HOLES TO USE IN THE L-BRACKET?

The L-bracket contains two legs; one leg measures 1" and is used to attach to the face of the door, one leg measures 1¾" and contains a series of holes to attach the L-bracket to the door bottom assembly.

FREQUENTLY ASKED QUESTIONS *(continued)*

9595 FLOATING FIRE DOOR BOTTOM GAP SOLUTION *(continued)*

DO I HAVE TO REMOVE THE DOOR TO INSTALL THE 9595 DOOR BOTTOM?

No. The 9595 door bottom can be installed while the door is on the hinges. This installation method requires the L-bracket to be used.

CAN I TRIM THE 9595 DOOR BOTTOM?

Yes. The 9595 door bottom can be trimmed up to 1½" from either end, (3" total).

HOW DO I SET THE POSITION IF THE GAP AT THE BOTTOM OF THE DOOR IS UNEVEN ACROSS THE WIDTH OF THE DOOR?

Use the end caps to set the side-to-side position. Identify the desired clearance at either edge of the door and install end caps to retain this location.

ARE THE END CAPS REQUIRED TO MAINTAIN UL CERTIFICATION?

The end caps are cosmetic only when the 9595 door bottom assembly can be used at full height extension.

DO I NEED TO SPECIFY THE ATTACHMENT METHOD WHEN ORDERING?

No, the 9595 door bottom contains all necessary hardware to support either method of attachment.

HOW DOES THE 9595 DOOR BOTTOM TRAVEL OVER THE UNEVEN FLOOR?

The door bottom assembly contains a spring-loaded tapered bottom component which has a maximum range of travel of ⅜".

WHAT IS INCLUDED IN THE HARDWARE PACK AND WHERE IS IT USED?

- #10 x 1½" PHPH SS SMS (DKB)
(L-Bracket For Wood Door)
- #8-32 x 1¾" PHP SS Thru-Bolt (DKB)
(L-Bracket For Steel Or Wood Door)
- #6 x ⅜" SS TEK
(L-Bracket Attachment To Door Bottom Assembly)
- #10 x 2" PHPH SS SMS
(Door Bottom Assembly Attachment To Bottom Rail Of Door)
- #6 x ¾" FHPH SS SMS (DKB)
(End Cap Attachment To Edge Of Door)

GAP90ME FIRE DOOR MEETING EDGE GAP SOLUTION

IS THE ATTACHMENT METHOD THE SAME FOR BOTH WOOD AND HOLLOW METAL DOORS?

No. Installation to a hollow metal door uses the #10 x ¾" FHPH SS TEK screws in combination with the GapGuard™ Fire Caulk. Installation to a wood door uses the #10 x 2½" FHPH SS SMS, which are anchored in ½" x 1½" cylindrical bores, in combination with the GapGuard™ Fire Caulk.

HOW DO I ACCOMMODATE AN UNEVEN GAP FROM THE TOP OF THE DOOR TO THE BOTTOM OF THE DOOR?

The formed metal edge can be pulled down (flattened) where needed while the metal edge is being fastened to the door, or flattened using a block of wood and a mallet. In either case, take caution to maintain a smooth transition when making any adjustment to the formed metal edge.

WHERE IS THE GAPGUARD™ FIRE CAULK USED ON THE FORMED METAL EDGE?

For installation to both wood and hollow metal doors, the concave side (underside) of the formed metal edge is filled with GapGuard™ Fire Caulk prior to placement on the door.

WHERE IS THE GAPGUARD™ FIRE CAULK USED ON THE DOOR?

For wood doors only, the GapGuard™ Fire Caulk is used to fill the ½" x 1½" cylindrical anchoring bores, prior to installing the formed metal edge to the edge of the door.

WHY ARE ANCHORING BORES REQUIRED ON WOOD DOORS?

The ½" x 1½" cylindrical anchoring bores provide structural integrity when used within the composite or mineral-based stile and rail material, commonly found within fire rated wood doors.

WHY IS THE GAPGUARD™ FIRE CAULK NECESSARY?

The GapGuard™ Fire Caulk provides structural integrity to both the formed metal edge and the attachment to the edge of the door, and is UL listed as a component within the GAP90ME meeting edge gap solution.

FREQUENTLY ASKED QUESTIONS *(continued)*

GAP90ME FIRE DOOR MEETING EDGE GAP SOLUTION *(continued)*

CAN I TRIM THE HEIGHT OF THE FORMED METAL EDGE?

Yes, the formed metal edge can be trimmed to match the height of the door.

DO I NEED TO USE A FORMED METAL EDGE ON BOTH DOORS?

No, the formed metal edge needs only to be applied to one of the doors.

CAN I USE A FORMED METAL EDGE ON BOTH DOORS?

Yes, so long as the excessive gap does not exceed $\frac{3}{8}$ " as per the UL Listing.

CAN I REDUCE THE THICKNESS OF THE FORMED METAL EDGE?

The formed metal edge can be pulled down (flattened) where needed while the metal edge is being fastened to the door, or the flattened using a block of wood and a mallet. In either case, take caution to maintain a smooth transition when making any adjustment to the formed metal edge.

HOW DO I HIDE THE FASTENERS?

The heads of the fasteners can be filled, sanded, and painted to match door.

WHAT TYPE OF LATCHING HARDWARE WILL THIS ACCOMMODATE?

The GAP90ME is not dependent upon the latching hardware and can be used in combination with the latching hardware currently approved for the opening.

MAY GAP90ME FORMED METAL EDGE BE MODIFIED?

Yes, the formed metal edge may be prepped to accommodate existing hardware. Where necessary, an NGP Strike Shim 9275 or 9225 may also be required for proper latchbolt engagement.

HOW DO I HANDLE FIRE PINS?

If fire pins are used, it is recommended to apply metal edge to door with fire pin receiver. Remove the receiver from door before installing formed metal edge. After formed metal edge is installed, reinstall the receiver, ensuring to face is flush with metal edge.

CAN I PAINT THE FORMED METAL EDGE?

Yes, the formed metal edge can be finish coated with like materials as the original door. Take caution to ensure that the embossed **UL Mark** is visible after painting.

GAP90ME FIRE DOOR MEETING EDGE GAP SOLUTION *(continued)*

IS THE FORMED METAL EDGE MARKED WITH THE UL STAMP?

Yes, the official **UL Mark** is the UL Shield & Category ID – Positive Pressure Tested Miscellaneous Fire Door Accessory.

IS THE FORMED METAL EDGE HANDED?

No, the formed metal edge is symmetrical.

WHAT DO I DO IF MY GAP IS GREATER THAN $\frac{3}{8}$ "?

An option is to use shims at the hinges to close the meeting edge gap to $\frac{3}{8}$ ", and then use GAP90ME. If the use of shims creates an excessive gap between the edge of the door and the frame larger than $\frac{1}{8}$ ", GAP90™ is required.

WHAT HARDWARE IS INCLUDED AND WHERE IS IT USED?

- #10 x $\frac{3}{4}$ " FHPH SS TEK
(Used On Hollow Metal Doors)
- #10 x $2\frac{1}{2}$ " FHPH SS SMS
(Used On Wood Doors)

GAPGUARD™ FIRE CAULK

HOW CAN THE GAPGUARD™ FIRE CAULK BE USED?

The GapGuard™ Fire Caulk was UL certified for use in wood and hollow metal fire doors and hollow metal frames. The certification included the use for thru-holes up to $\frac{1}{2}$ " diameter, as well as a component of certified GapGuard™ Accessories.

CAN GAPGUARD™ FIRE CAULK BE USED ON ANY HOLLOW METAL OR WOOD FIRE-RATED DOOR?

Yes, up to 90 minute fire rating. The GapGuard™ Fire Caulk can be used to repair fire doors as well as accommodate removal or replacement of hardware.

WHAT IS THE WORKING TIME FOR THE GAPGUARD™ FIRE CAULK?

The working time should be kept to a minimum as the GapGuard™ Fire Caulk will form a skin within several minutes after application.

HOW LONG AFTER APPLICATION SHOULD I CLEAN UP EXCESS?

Immediately. Use soap and water and remove any excess, focusing on areas where sanding, filling and/or painting will occur.

WHAT IS THE CURE TIME?

The cure time is dependent on the size of the caulk bead, but full cure is achieved within 24 hours.

FREQUENTLY ASKED QUESTIONS *(continued)*

GAPGUARD™ FIRE CAULK *(continued)*

WILL GAPGUARD™ FIRE CAULK FREEZE?

Yes. Product is for indoor use only and must be kept from freezing prior to use.

WHAT IS THE SHELF LIFE FOR THE GAPGUARD™ FIRE CAULK?

12 months

WHAT COLOR IS THE GAPGUARD™ FIRE CAULK?

Tan. The color blends naturally with many door finishes but can be treated with other finish products to match the original door condition.

CAN I APPLY WOOD PUTTY AND OTHER SURFACE TREATMENTS OVER THE GAPGUARD™ FIRE CAULK?

Yes, after fire caulk has reached full cure.

CAN I SAND THE GAPGUARD™ FIRE CAULK?

Yes. Take precaution to clean as much excess as possible after application to minimize sanding required.

CAN I STAIN THE GAPGUARD™ FIRE CAULK?

While not recommended, stain can be applied directly to the cured GapGuard™ Fire Caulk. For best color match it is recommended to apply wood or wood filler prior to staining.

CAN I PAINT THE GAPGUARD™ FIRE CAULK?

Yes, fully cured GapGuard™ Fire Caulk can be painted. For best results, multiple coats are recommended.

HP90-MORT MORTISE HARDWARE PREP FILLER

IS THERE A DIFFERENCE IN APPLICATION BETWEEN A WOOD DOOR AND A HOLLOW METAL DOOR?

No. Application to wood and hollow metal doors should be treated the same, using the HP90 fire rated panel, GapGuard™ Fire Caulk and filler plates are required, see installation instructions.

IS THE GAPGUARD™ FIRE CAULK REQUIRED?

Yes. The GapGuard™ Fire Caulk is a component of the UL listed solution and is necessary to fill voids as well as secure the fire-rated panel within the hardware prep.

IS THE GAPGUARD™ FIRE CAULK REQUIRED BEHIND THE STRIKE FILLER PLATE ON THE FRAME?

While not required, application of GapGuard™ Fire Caulk provides additional integrity to the hardware.

HP90-MORT MORTISE HARDWARE PREP FILLER *(continued)*

CAN I CUT THE HP90 FIRE-RATED PANEL TO FIT THE CUTOUT SIZE?

Yes. The fire-rated panel is provided to accommodate multiple sizes of mortise lockset hardware. As determined by the particular hardware prep, the fire-rated panel can be machined to size using wood working tools.

HOW DO I KNOW WHICH OF THE FILLER PLATES TO USE?

The HP90-MORT kit is supplied with various sizes of steel filler plates for multiple types of mortise lockset hardware. The filler plates will need to be determined based on the particular hardware prep.

HP90-FB FLUSH BOLT HARDWARE PREP FILLER

IS THERE A DIFFERENCE IN APPLICATION BETWEEN A WOOD DOOR AND A HOLLOW METAL DOOR?

No. Application to wood and hollow metal doors should be treated the same, using the HP90 fire rated panel, GapGuard™ Fire Caulk and filler plates are required, see installation instructions.

IS THE GAPGUARD™ FIRE CAULK REQUIRED?

Yes. The GapGuard™ Fire Caulk is a component of the UL listed solution and is necessary to fill voids as well as secure the fire-rated panel within the hardware prep.

IS THE GAPGUARD™ FIRE CAULK REQUIRED BEHIND THE STRIKE FILLER PLATE ON THE FRAME?

While not required, application of GapGuard™ Fire Caulk provides additional integrity to the hardware.

CAN I CUT THE HP90-FIRE RATED PANEL TO FIT THE CUTOUT SIZE?

Yes. The fire-rated panel is provided to accommodate multiple types of flush bolt hardware. As determined by the particular hardware prep, the fire-rated panel can be machined to size using wood working tools.

HOW DO I KNOW WHICH OF THE FILLER PLATES TO USE?

The HP90-FB kit is supplied with various sizes of steel filler plates for multiple types of mortise lockset hardware. The filler plates will need to be determined based on the particular hardware prep.

FREQUENTLY ASKED QUESTIONS *(continued)*

HP90-CYL CYLINDRICAL HARDWARE PREP FILLER

IS THERE A DIFFERENCE IN APPLICATION BETWEEN A WOOD DOOR AND A HOLLOW METAL DOOR?

Yes. Application to hollow metal doors requires the use of round filler plates at the face of the door.

For wood doors, the use of the round filler plates is optional. For both door types, the HP90 fire rated panel, GapGuard™ Fire Caulk and filler plates are required, see installation instructions.

IS THE GAPGUARD™ FIRE CAULK REQUIRED?

Yes. The GapGuard™ Fire Caulk is a component of the UL listed solution and is necessary to fill voids as well as secure the fire-rated panel within the hardware prep.

IS THE GAPGUARD™ FIRE CAULK REQUIRED BEHIND THE STRIKE FILLER PLATE ON THE FRAME?

While not required, application of GapGuard™ Fire Caulk provides additional integrity to the hardware.

HOW DO I KNOW WHICH OF THE FILLER PLATES TO USE?

The HP90-CYL kit is supplied with various sizes of steel filler plates for multiple types of cylindrical lockset hardware. The filler plates will need to be determined based on the particular hardware prep.

HOW DO I KNOW WHICH HP90 FIRE-RATED PANELS TO USE?

The UL listing requires the use of two cylindrical fire rated panels in the thru-hole at the faces of the door, and two cylindrical fire-rated panels within the latch bolt bore. Multiple sized cylindrical fire-rated panels are provided for application within the latch bolt bore, use the largest diameter size that will fit within the bore diameter.

CAN I CUT THE HP90-FIRE RATED PANEL TO FIT THE CUTOUT SIZE?

Yes. The fire-rated panel is provided to accommodate multiple types of cylindrical hardware. As determined by the particular hardware prep, the fire-rated panel can be machined to size using wood working tools.

WHEN DO I NEED TO USE THE ROUND FILLER PLATE?

The round filler plates are required for use on hollow metal doors and are optional for use on wood doors.

HP90-CYL CYLINDRICAL HARDWARE PREP FILLER *(continued)*

IS THE ROUND FILLER PLATE UL MARKED?

Yes, one of the round filler plates is embossed with the **UL Mark**, as are the latch edge and strike filler plates.

IF THE ROUND FILLER PLATE IS NOT USED ON A WOOD DOOR, HOW IS THE UL MARK DEMONSTRATED?

The **UL Mark** is embossed on the latch edge and strike filler plates. Additionally, the specific product information should be kept with the record of repairs within the maintenance log.

WHY IS THE ROUND FILLER PLATE REQUIRED FOR HOLLOW METAL DOORS AND NOT WOOD DOORS?

The type of fire-rated door core determines the requirement. Fire-rated wood doors use a solid core material, such as composite or mineral-based, which provides core material to bond to the HP90 cylindrical fire-rated panels when the fire caulk cures. Fire-rated hollow metal doors use internal core types which may or may not have material to bond to the HP90 cylindrical fire-rated panels, and therefore the UL listing requires the use of the round filler plates to ensure structural integrity of the assembly.

CAN I USE WOOD OVER THE HP90 FILLER SYSTEM TO MATCH THE FACE OF THE DOOR?

Yes. Up to 3mm (1/8") high density fiberboard or equivalent density wood can be used to provide the desired surface finish.

CAN I USE HPL (LAMINATE) OVER THE HP90 FILLER SYSTEM TO MATCH THE FACE OF THE DOOR?

Yes. The face of the door can be treated to match the original condition of the fire-rated door construction.

CAN I APPLY WOOD PUTTY AND OTHER SURFACE TREATMENTS OVER THE GAPGUARD™ FIRE CAULK?

Yes, after the GapGuard™ Fire Caulk has reached full cure.

CAN I SAND THE GAPGUARD™ FIRE CAULK?

Yes. Take precaution to clean as much excess as possible after application to minimize sanding required.

FREQUENTLY ASKED QUESTIONS *(continued)*

HP90 HARDWARE PREP FILLER

WHERE DO I USE THESE HP90 FILLER PANELS?

The HP90 filler panels are used in combination with the GapGuard™ Fire Caulk to fill thru-holes between the faces of the wood and hollow metal doors, between ½" and up to 2 ⅝" diameter.

HOW DO I USE THE HP90 FILLER PANELS FOR WOOD DOORS?

Two HP90 filler panels are required in combination with the GapGuard™ Fire Caulk. Based on the size of the thru-hole, use the appropriate sized HP90 filler panel that will fit within the thru-hole and provide for up to a maximum ¼" gap to allow for application of GapGuard™ Fire Caulk.

HOW DO I USE THE HP90 FILLER PANELS FOR HOLLOW METAL DOORS?

The HP90-CYL is used for hollow metal doors, which includes the required round filler plates.

WHY IS THE ROUND FILLER PLATE REQUIRED FOR HOLLOW METAL DOORS AND NOT WOOD DOORS?

The type of fire-rated door core determines the requirement. Fire rated wood doors use a solid core material, such as composite or mineral-based, which provides core material to bond to the HP90 cylindrical fire-rated panels when the fire caulk cures. Fire-rated hollow metal doors use internal core types which may or may not have material to bond to the HP90 cylindrical fire-rated panels, and therefore the UL listing requires the use of the round filler plates to ensure structural integrity of the assembly.

DO I HAVE TO USE THE GAPGUARD™ FIRE CAULK?

Yes. Only the GapGuard™ Fire Caulk meets the UL Certification requirements for this application.

CAN I USE WOOD OVER THE HP90 FILLER SYSTEM TO MATCH THE FACE OF THE DOOR?

Yes. Up to 3mm (⅛") high density fiberboard or equivalent density wood can be used to provide the desired surface finish.

HP90 HARDWARE PREP FILLER *(continued)*

CAN I USE HPL (LAMINATE) OVER THE HP90 FILLER SYSTEM TO MATCH THE FACE OF THE DOOR?

Yes. The face of the door can be treated to match the original condition of the fire rated door construction.

CAN I APPLY WOOD PUTTY AND OTHER SURFACE TREATMENTS OVER THE GAPGUARD™ FIRE CAULK?

Yes, after the GapGuard™ Fire Caulk has reached full cure.

CAN I SAND THE GAPGUARD™ FIRE CAULK?

Yes. Take precaution to clean as much excess as possible after application to minimize sanding required.

CAN I PAINT THE GAPGUARD™ FIRE CAULK?

Yes, fully cured GapGuard™ Fire Caulk can be painted. For best results, multiple coats are recommended.





For the complete list of GapGuard™ Fire Door Accessories, the most up-to-date product information and installation instructions, scan the QR code or visit ngp.com.



ngp.com
1-800-NGP-RUSH

FAX: (800) 255-7874
QUOTES: quotes@ngp.com

NGP MEMPHIS

4985 East Raines Road
Memphis, TN 38118
orders@ngp.com

NGP CARSON CITY

3689 Arrowhead Drive
Carson City, NV 89706
carsonorders@ngp.com