



**REFERENCE STANDARDS RS-16
PLUMBING AND GAS PIPING**

***LIST OF REFERENCED NATIONAL STANDARDS**

ANSI-A21.4	Cement Mortar Lining for Cast Iron Pipe and Fittings	1964
ANSI-A21.6	Cast-Iron Pipe Centrifugally Cast in Metal Molds for Water or Other Liquids.....	1962
ANSI-A21.8	Cast-Iron Pipe Centrifugally Cast in Sand-Lined Molds for Water or Other Liquids	1962
ANSI-A40.4	Air Gaps in Plumbing Systems	1942
ANSI-A40.5	Threaded Cast Iron Pipe for Drainage, Vent, and Waste Services.....	1943
ANSI-A40.6	Backflow Preventers in Plumbing Systems	1943
ANSI-106.1	Standard and Extra Strength Perforated Clay Pipe, Specifications for	1962
ANSI-A106.3	Standard Strength Clay Sewer Pipe, Specifications for	1965
** ANSI/AHAM FWD-1	1992
ANSI/ASME A112.18.1M	Finished and Rough Brass Plumbing Fixture Fittings	1979
ANSI/ASME A112.19.1M	Enameled Cast Iron Plumbing Fixtures	1987
ANSI A112.19.2M	Vitreous China Plumbing Fixtures	1982
ANSI/ASME A112.19.3M	Stainless Steel Plumbing Fixtures (Designed for Residential Use)	1987
ANSI/ASME A112.19.4M	Porcelain Enameled Formed Steel Plumbing Fixtures	1984
ANSI-B2.1	Pipe Threads (Except Dryseal) (Partial Revision of B2.1-1945)	1968
ANSI-B16.3	Malleable-Iron Screwed Fittings, 150 and 300 lb. (Revision and Consolidation of B16.3-1951 and B16.19-1951)	1977
ANSI-B16.4	Cast-Iron Screwed Fittings, 125 and 250 lbs.	1977
ANSI-B16.12	Cast-Iron Screwed Drainage Fittings	1976
ANSI-B16.15	Cast-Bronze Screwed Fittings, 125 and 250 lb. (Revision and Consolidation of B16.15-1958 and B16.17-1949)	1978
ANSI-B16.18	Cast-Bronze Solder-Joint Pressure Fittings	1978
ANSI-B16.22	Wrought Copper and Bronze Solder-Joint Drainage Fittings.....	1973
ANSI-B16.23	Cast-Bronze Solder-Joint Drainage Fittings	1976
ANSI-B16.24	Bronze Flanges and Flanges Fittings 150 and 300 lb.	1979
ANSI B31.2	Fuel Gas Piping	1968
ANSI B31.8	Gas Transmission and Distribution Piping Systems	1975
ANSI-B36.1	Welded and Seamless Steel Pipe, Specifications for	1966
ANSI-B36.2	Welded Wrought-Iron Pipe, Specifications for	1966
ANSI-B36.19	Stainless Steel Pipe	1976
ANSI-B36.20	Black and Hot Dipped Zinc-Coated (Galvanized) Welded and Seamless Steel Pipe for Ordinary Uses, Specifications for	1966
ANSI-C72.1	Household Automatic Electric Storage-Type Water Heaters, Standard for.....	1972
ANSI-G8	Zinc-Coated (Galvanized) Iron or Steel Sheets, Coils, etc.	1964
ANSI-H23.1	Seamless Copper Water Tubes, Specification for	1967
ANSI-H23.3	Seamless Copper Tube, Specification for	1965
ANSI-H26.1	Seamless Copper Pipe, Standard Sizes, Specification for.....	1963

Reference Standard 16

ANSI-H26.2	Threadless Copper Pipe, Specification for	1963
ANSI-H27.1	Seamless Red Brass Pipe, Standard Sizes, Specification for	1963
ANSI-H36.1	Seamless Brass Tube, Specification for	1967
ANSI/NFiPA 50	Standard for Bulk Oxygen Systems at Consumer Sites	1985
ANSI/NFiPA 99	Standard for Health Care Facilities, as modified	1987
** ANSI/UL 430	Standard for Waste Disposers (5th Edition).....	1994
ANSI-Z4.2	Drinking Fountains, Specifications for	1942
ANSI-Z21.10.1	Gas Water Heaters, Volume I, Automatic Storage Type, Water Heaters with inputs of 75,000 BTU per hour or less	1981
ANSI Z21.10.3	Gas Water Heaters, Volume III, Circulating Tank, Instantaneous and Large Automatic Storage Type Water Heaters	1981
ANSI-Z21.22	Relief Valves and Automatic Gas Shut-Off Devices for Hot Water Supply Systems, Listing Requirements for	1979
ANSI Z223.1/NfiPA No. 54	National Fuel Gas Code including Addenda Z223.1a-1978.....	1974
ASME	Boiler and Pressure Vessel Code	1980
API 1104	Standard for Welding Pipelines and Related Facilities	1977
ASTM-B32	Specification for Solder Metal	1976
ASTM-B36	Specification for Brass Plate, Sheet, Strip, and Rolled Bar	1977
ASTM-B121	Specification for Leaded Brass Plate, Sheet, Strip, and Rolled Bar	1976
ASTM-B135	Seamless Brass Tube, Specification for	1971a
ASTM-B146	Leaded Yellow Brass Sand Casting for General Purposes, Specification for.....	1952
ASTM-B152	Copper Sheet, Strip, Plate, and Rolled Bar, Specification for	1979
ASTM-B260	Brazing Filler Metal (Tentative), Specification for	1962T
ASTM-C4	Specification for Clay Drain Tile	1962
ASTM-C13	Specification for Standard Strength Clay Sewer Pipe (Tentative).....	1964T
ASTM-C14	Specification for Concrete Sewer, Storm Drain, and Culvert Pipe.....	1979
ASTM-C76	Specification for Reinforced Concrete Culvert, Storm Drain, and Sewer Pipe.....	1979
ASTM-C200	Specification for Extra Strength Clay Pipe (Tentative)	1965T
ASTM-C425	Specification for Vitrified Clay Pipe Joints Using Materials Having Resilient Properties... 1977	
ASTM-C428	Specification for Asbestos-Cement Non-pressure Sewer Pipe.....	1978
ASTM-C443	Specification for Joints for Circular Concrete Sewer and Gaskets.....	1978
ASTM-C508	Specification for Asbestos-Cement Perforated Underdrain Pipe.....	1978a
ASTM-D2513	Thermoplastic Gas Pressure Pipe, Tubing and Fittings	1976
ASTM-E84	Method of Test for Surface Burning Characteristics of Building Materials.....	1981
AWWA C204	Protective Coating Coal-Tar Enamel	1951
CISPI Designation 301	Standard Specification for Hubless Cast Iron Soil Pipe and Fittings for Sanitary and Storm Drain, Waste, and Vent Piping Applications	1985
CISPI Designation 310	Specification for Cast Iron Soil Pipe Institute's Approved Coupling for Use in Connection with Hubless Cast Iron Soil Pipe and Fittings for Sanitary and Storm Drain, Waste and Vent Piping Applications	1985

Reference Standard 16

CS-111	Earthenware (Vitreous-Glazed) Plumbing Fixtures	1943
CS-177	Bituminous-Coated Septic Tanks	1962
CS-188	Cast-Iron Soil Pipe and Fittings	1966
CS-270	Non-Metallic Pipe and Fittings Acrylonitrile- Butadiene-Styrene (ABS).....	1965
CS-272	Non-Metallic Pipe and Fittings Polyvinyl Chloride (PVC).....	1965
FS-HH-C536a	Compound, Plumbing-Fixture Setting	1954
FS-HH-G116	Gaskets, Plumbing-Fixture-Setting	1936
FS-QQ-L156(1)	Lead Caulking	1946
FS-QQ-C40	Caulking: Lead Wool and Lead Pig	1965
FS-QQ-L201d	Lead Sheet	1961
FS-RR-S726(1)	Stills, Water, Portable (Without Heating Device), for U.S.P. "Distilled Water".....	1950
FS-SS-P361b	Pipe, Clay, Sewer	1962
FS-SS-S169	Sealer, Joint, Sewer, Mineral-Filled, Hot-Pour	1954
FS-WW-F406a(1)	Flange-Dimensions, Standard: (Classes 125 and 250 Cast-Iron Flanges; Classes 150, 250, and 300 Bronze Flanges) (For Land Use)	1943
FS-WW-H171C	Hangers and Supports, Pipe	1964
FS-WW-H191a	Heater, Water, Steam-Hot Water Heated (Instantaneous, Steam, Water Converter Type)..	1964
FS-WW-N351a(1)	Nipples, Pipe, Threaded	1960
FS-WW-U531C	Unions, Pipe Steel or Malleable Iron; Thread Connection.....	1965
FS-WW-P356	Pipe, Cast-Iron; Drainage, Vent, and Waste (Threaded).....	1936
FS-WW-P360a	Pipe, Cast-Iron; Pressure Gas and Water	1959
FS-WW-P401C	Pipe and Pipe Fittings, Cast-Iron, Soil	1963
FS-WW-P406b(1)	Pipe Steel (Seamless and Welded) (for Ordinary Use)	1964
FS-WW-P471a(2)	Pipe-Fittings; Bushings, Locknuts, and Plugs; Brass or Bronze, Iron or Steel, and Aluminum (Screwed); 125-150 Pounds.....	1964
FS-WW-P541b(2)	Plumbing Fixtures-Land Use	1962
FS-WW-U516	Unions; Brass or Bronze, 250-Pound	1933
FS-WW-U536(1)	Unions; Malleable Iron or Steel, 300-Pound	1933
FS-WW-V51a(2)	Valves, Bronze; Angle, Check and Globe, 125- and 150- Pound Screwed and Flanged (for Land Use)	1954
FS-WW-V54b	Valves, Gate, Bronze, 125- and 150-Pound, Screwed and Flanged (for Land Use)...	1962
FS-WW-V58(1)	Valves, Cast Iron, Gate; 125- and 250-Pound Screwed and Flanged (for Land Use)...	1946
16 NYCRR 255	Transmission and Distribution of Gas	1978
ANSI/IEEE 515	Recommended Practice for the Testing, Design, Installation and Maintenance of Electrical Resistance Heat Tracing for Industrial Applications	1983

**Local Law 100-1989; Local Law 29-1989; Local Law 29-1987; Local Law 82-1986; Local Law 30-1982; 1025-88 BCR*

***Local Law 71-1997*

TABLE OF CONTENTS

Section Definitions

P101.0 General Provisions

- P101.1 Protection of Pipes
- P101.2 Trenching, Excavation, and Backfill
- P101.3 Sleeves
- P101.4 Ratproofing
- P101.5 Toilet Facilities for Workmen

P102.0 Materials

- P102.1 General Requirements
- P102.2 Standards for Plumbing Materials
- P102.3 Identification Materials
- P102.4 Piping System Materials

P103.0 Joints and Connections

- P103.1 Types of Joints for Piping Materials
- P103.2 Joints Between Different Piping Materials
- P103.3 Connections Between Drainage Piping and Certain Fixtures
- P103.4 Tightness
- P103.5 Waterproofing of Openings
- P103.6 Other Joints

P104.0 Plumbing Fixtures

- P104.1 Requirements
- P104.2 Installation of Fixtures
- P104.3 Overflows
- P104.4 Water Closets
- P104.5 Urinals
- P104.6 Flushing Devices for Water Closets and Urinals
- P104.7 Lavatories
- P104.8 Bathtubs
- P104.9 Showers
- P104.10 Sinks
- P104.11 Dishwashing Machines
- P104.12 Automatic Clothes Washers
- P104.13 Laundry Trays
- P104.14 Garbage Can Washers
- P104.15 Fixture Strainers
- P104.16 Drinking Fountains
- P104.17 Floor Drains
- P104.18 Drains for Drip Pipes
- P104.19 Funnel Drains
- P104.20 Special Plumbing Fixtures

P105.0 Traps and Cleanouts

- P105.1 Fixture Traps
- P105.2 Building (House) Traps
- P105.3 Drainage Pipe Cleanouts
- P105.4 Interceptors, Separators, and Neutralizing Pits
- P105.5 Interceptors, Separators, and Neutralizing Pits for Specific Services
- P105.6 Venting of Interceptors, Separators, and

Neutralizing Pits

- P105.7 Accessibility of Interceptors, Separators and Neutralizing Pits
- P105.8 Maintenance of Interceptors, Separators and Neutralizing Pits
- P105.9 Backwater Valves
- P105.10 Industrial Wastes Sampling Manholes

P106.0 Hangers and Supports

- P106.1 Material
- P106.2 Attachment to Building
- P106.3 Intervals of Supports
- *P106.4 Installation of No-Hub Type Cast Iron Soil Pipe, Fittings, and Couplings

**Local Law 100-1989*

P107.0 Water Supply and Distribution

- P107.1 Permits
- P107.2 Water Service
- P107.3 Meters
- P107.4 Check Valves
- P107.5 Water Supply Distribution System
- P107.6 Water Supply Control Valves
- P107.7 Auxiliary Water Systems
- P107.8 Water Supply Tanks
- P107.9 House and Booster Pumps
- P107.10 Protection of Potable Supply
- P107.11 Toxic Materials and Substances
- P107.12 Used Piping
- P107.13 Prohibited Connections to Fixtures and Equipment
- P107.14 Connections to Mechanical Equipment and Systems
- P107.15 Refrigeration Unit Condensers and Cooling Jackets
- P107.16 Air Conditioning and Refrigeration
- P107.17 Used Water Return Prohibited
- P107.18 Protection Against Backflow and Back-Siphonage
- P107.19 Approval of Devices
- P107.20 Protection of Potable Water Supply Outlets
- P107.21 Preheating Apparatus
- P107.22 (Blank)
- P107.23 Chemical Solution Tanks or Apparatus
- P107.24 Bedpan Washers
- P107.25 Laboratory Outlets
- P107.26 Hot Water Supply System
- P107.27 Disinfection of Potable Water Systems

P108.0 Sanitary Drainage Piping

- P108.1 Permits
- P108.2 Street Sewer Connections
- P108.3 Abandonment of Existing Building Sewer Connections

Reference Standard 16

- P108.4 Building (House Traps)
- P108.5 Fresh Air Inlets
- P108.6 Drainage Below Sewer Level
- P108.7 Sub-Soil Drainage
- P108.8 Drainage Piping Installation
- P108.9 Sanitary Drainage Fixture Units
- P108.10 Sizing the Sanitary Drainage Piping
- P108.11 Drip Pipes

P109.0 Vent Piping

- P109.1 Size of Vents
- P109.2 Protection of Trap Seals
- P109.3 Vent Stack and Stack Vents
- P109.4 Vent Terminals
- P109.5 Vent Grading and Connections
- P109.6 Stack Venting
- P109.7 Common Vents
- P109.8 Fixture Vents
- P109.9 Relief Vents
- P109.10 Suds Pressure Zones Vents
- P109.11 Permitted Combination Waste and Vent Systems

P110.0 Storm Drainage Piping

- P110.1 Permits
 - *P110.2 Disposal of Storm Water
 - P110.3 Storm Water Drainage to Sanitary Sewer Prohibited
 - P110.4 Size of Storm Drains and Leaders
 - P110.5 Values for Continuous Flow
 - P110.6 Controlled Flow Storm Water System
 - P110.7 Traps on Storm Drains and Leaders
 - P110.8 Leaders or Storm Water Piping
 - P110.9 Roof Drain Strainers
 - P110.10 Roof Drain Flashings Required
 - P110.11 Expansion Joints Required
 - P110.12 Sanitary and Storm Sewers
 - *P110.13 On-Site Disposal
- *Local Law 103-1989; Local Law 7-1984*

P111.0 Indirect Waste Piping

- P111.1 Indirect Waste Required
- P111.2 Common Indirect Wastes
- P111.3 Venting
- P111.4 Sizing
- P111.5 Receptors or Sumps
- P111.6 Condensers and Sumps

P112.0 Special and Miscellaneous Waste Piping

- P112.1 Industrial Wastes
- P112.2 Chemical Wastes
- P112.3 Flammable Solvents or Oil Wastes
- P112.4 Radioactive Wastes

P113.0 Individual Sewage Systems

- P113.1 Information Required
- P113.2 Individual Sewage Disposal Systems

- P113.3 Individual Sewage Disposal System (One and Two-Family Dwellings)
- P113.4 Housing Development Sewage Disposal Systems
- P113.5 General Requirements
- P113.6 Location
- P113.7 Septic Tanks
- P113.8 Distribution Box
- P113.9 Soil Percolation Tests
- P113.10 Seepage Units
- P113.11 Subsurface Disposal Field
- P113.12 Maintenance

P114.0 Hospital and Institutional Plumbing

- P114.1 General
- P114.2 Definitions for Special Hospital Fixtures and Equipment
- P114.3 Requirement for Special Hospital Fixtures and Equipment
- P114.4 Plumbing in Mental Hospitals
- P114.5 Number of Plumbing Fixtures
- P114.6 Drainage and Venting
- P114.7 Sterilizer Wastes
- P114.8 Vapor Vents
- P114.9 Sizing of Sterilizer Vent Stacks
- P114.10 Water Supply
- P114.11 Vacuum Systems
- P114.12 Oxygen and Nitrous Oxide Systems

P115.0 Gas Piping

- P115.1 General Requirements for Gas Piping
- P115.2 Gas Service Piping Connections
- P115.3 Gas Regulator and Gas Regulator Vent Outlets
- P115.4 Outside Gas Cut-Off
- P115.5 Gas Meter Location
- P115.6 Gas Piping Materials and Fittings
- P115.7 Installation of Gas Piping
- P115.8 Gas Piping Sizes

P116.0 Swimming Pools and Display Pools or Fountains

- P116.1 Swimming Pools
- P116.2 Display Pools and Fountains

LIST OF TABLES

Index Table No.

- RS 16-1 Standards for Plumbing Materials
- RS 16-2 Deleted
- RS 16-3 Caulking Ferrules
- RS 16-4 Soldering Bushings
- RS 16-5 Minimum Number of Plumbing Fixtures Required
- RS 16-6 Minimum Size of Fixture Traps for Various Types of Plumbing Fixtures
- RS 16-7 Minimum Rate of Flow and Minimum Required Pressure During Flow for Sizing Individual Branch Supplies for Plumbing Fixtures
- RS 16-8 Size of Overflows for Gravity and Suction

Reference Standard 16

- Tanks
- RS 16-9 Size of Weirs for Gravity and Suction Tanks
- RS 16-10 Suction Tank Sizes
- RS 16-11 Cross-Connection Where Protective Devices are Required and Critical Level (C-L) Setting for Vacuum Breakers
- RS 16-12 Sanitary Drainage Fixture Unit Valves
- RS 16-13 Maximum Permissible Loads for Sanitary Drainage Piping (in terms of fixture units)
- RS 16-14 Size of Vent Stacks and Branch Vents
- RS 16-15 Deleted
- RS 16-16 Deleted
- RS 16-17 Size of Horizontal Storm Drains
- RS 16-18 Size of Vertical Leaders
- RS 16-19 Size of Roof Gutters*
- *Local Law 85-1973*
- RS 16-20 Fixture Unit-Drainage Square Footage Equivalent
- RS 16-21 Minimum Distances Between Sewage System Components and Between Components and Encumbrances
- RS 16-22 Minimum Capacity of Septic Tanks
- RS 16-23A Design Data for Absorptive Capacity of Disposal Field and Seepage Pits
- RS 16-23B Design Data for Absorptive Capacity of Disposal Field and Seepage Pits
- RS 16-24 Limiting Dimensions of Disposal Field Components
- RS 16-25 Minimum Number of Fixtures for Hospitals and Institutions
- RS 16-26 Stack Sizes for Bedpan Steamers and Boiling Type Sterilizers, and of Connections Permitted
- RS 16-27 Stack Sizes for Pressure Sterilizers and Number of Connections Permitted
- RS 16-28 Fixture Water Supply Protection

LIST OF ILLUSTRATIONS

Figure No.

- RS 16-1 Methods of Connecting Overflow from Gravity House and Suction Water Supply Tanks
- RS 16-2 Sizing of Branch Vent Piping and Drop Vents to First Floor, Basement and Cellar Fixtures
- RS 16-3 Deleted
- RS 16-4 Vent Arrangements
- RS 16-5 Deleted
- RS 16-6 Offsets in Buildings Five Stories or More
- RS 16-7 Relief Vents for Stack of More than Ten Branch Intervals
- RS 16-8 Suds Pressure Zones
- RS 16-9 Combination Waste and Vent Oil Waste Drainage
- **RS 16-9A Yard Drain With Sump
- **RS 16-9B Detail of Dry Well With Sand Column
- RS 16-10 Acid Drainage for Buildings Four Stories or Less

RS 16-11 Acid Drainage for Buildings Over Four Stories

*RS 16-12A Typical Concrete Septic Tank

*RS 16-12B Typical Metal Septic Tank

*RS 16-13A Absorption Type System

*RS 16-13B Absorption Type

**Local Law 85-1973*

***Local Law 103-1989*

Section P100.0 Definitions

The following definitions shall be used in the application of this reference standard.

AIR-BREAK (DRAINAGE SYSTEM).—A piping arrangement in which a drain from a fixture, appliance, or device discharges through an air break into a fixture, receptacle, or interceptor at a point above the flood level rim of the receptacle.

AIR GAP (WATER DISTRIBUTION SYSTEM).—The unobstructed vertical distance through the free atmosphere between the lowest opening from any pipe or faucet supplying water to a tank, plumbing fixture, or other device and the flood level rim of the receptacle.

BACKFLOW.—The flow of water or other liquids, mixtures, or substances into the distributing pipes of a potable supply of water from any source or sources other than its intended source. (See back-siphonage.)

BACK-SIPHONAGE.—The flowing back of used, contaminated, or polluted water from a plumbing fixture or vessel into a water-supply system due to a negative pressure in such pipe. (See backflow.)

BATTERY OF FIXTURES.—Any group of two or more similar adjacent fixtures that discharge into a common horizontal waste or soil branch.

BRANCH.—That part of a piping system other than a main, riser, or stack that extends to fixtures on two or less consecutive floors.

BRANCH INTERVAL.—A distance along a soil or waste stack corresponding in general to a story height, but in no case less than 8 ft. within which the horizontal branches from one floor or story of a building are connected to the stack.

BRANCH VENT.—A vent connecting one or more individual vents with a vent stack or stack vent.

BUILDING HOUSE DRAIN.—That part of the lowest piping of a drainage system that receives the discharge from the soil, waste, and other drainage pipes of the building and conveys it to the building house sewer by gravity; the building house drain shall be considered to extend 5 ft. outside the building wall.

BUILDING HOUSE DRAIN (COMBINED).—A building house drain that conveys both storm water and sewage or other drainage.

BUILDING HOUSE DRAIN (SANITARY).—A building house drain carrying sewage only.

BUILDING GRAVITY DRAINAGE SYSTEM.—A drainage system that drains by gravity into the

Reference Standard 16

building house sewer.

BUILDING HOUSE SEWER.—That part of the horizontal piping of a drainage system that extends from the end of the building house drain and that receives the discharge of the building house drain and conveys it to a public sewer, private sewer, individual sewage-disposal system or other point of disposal.

BUILDING HOUSE SEWER (COMBINED).—A building house sewer that conveys both sewage and storm water and other clear water wastes.

BUILDING HOUSE SEWER (SANITARY).—A building house sewer carrying sewage only.

BUILDING HOUSE STORM DRAIN.—That part of the lowest piping of a storm drainage system that receives clear water drainage from leaders, surface run-off, ground water, subsurface water, condensate, cooling water or other similar storm or clear water drainage pipes inside of the walls of the building and conveys to it to the building house storm sewer by gravity; the building house storm drain shall be considered to extend 5 ft. outside of the building wall.

BUILDING HOUSE STORM SEWER.—That part of the horizontal piping of the storm drainage system that extends from the building house storm drain to the public storm sewer, combined sewer, or other point of disposal.

BUILDING SUB-HOUSE DRAIN.—The portion of a house drainage system that conveys the drainage from the lower portion of the building to an ejector pit or sump pit from which it is pumped into the building house sewer.

BUILDING HOUSE TRAP.—A trap, or assembly of fittings, installed in the building house drain to prevent circulation of air between the house drainage system and the building house sewer.

CESSPOOL.—A covered excavation in the ground that receives the discharge of domestic sewage or other organic wastes from a drainage system, so designed as to retain the organic matter and solids, but permitting the liquid to seep through the bottom and sides.

COMBINATION FIXTURE.—A fixture combining one sink and tray or two- or three-compartment sink or tray in one unit.

COMBINATION WASTE AND VENT SYSTEM.—A specially designed system of waste piping embodying the horizontal wet venting of one or more sinks or floor drains by means of a common waste and vent pipe.

COMMON VENT.—A vent connecting at the junction of two fixture drains and serving as a vent for both fixtures and drains.

CONTINUOUS VENT.—A vertical vent that is a continuation of the drain to which it connects.

CONTINUOUS WASTE.—A drain from two or three fixtures connected to a single trap.

CROSS-CONNECTION.—A physical connection

or arrangement between two otherwise separate piping systems, one of which contains potable water and the other with either water of unknown or questionable safety or steam, gases, or chemicals whereby there can be a flow from one system to another.

DEAD END.—A branch leading from a soil, waste, or vent pipe, building house drain, or building house sewer, which is terminated to a developed distance of 2 ft. or more by means of a plug or other closed fitting.

DEVELOPED LENGTH.—The length along the center line of pipe and fittings, both horizontal and vertical.

DIAMETER.—Unless otherwise specifically stated, the term "diameter" is the nominal diameter as designated commercially.

DOMESTIC SEWAGE.—The water-borne wastes derived from ordinary living processes.

DRAIN.—Any pipe that carries waste water or water-borne wastes in a building drainage system.

DRAINAGE SYSTEM.—Includes all the piping within public or private premises, which conveys sewage, rain water, or other liquid wastes to a legal point of disposal, but does not include the mains of a public sewer system or private or public sewage-treatment or disposal plant.

DRY WELL.—See leaching well or pit.

DUAL VENT.—See common vent.

EFFECTIVE OPENING.—The minimum cross-sectional area at the point of water-discharge, measured or expressed in terms: (1) diameter of a circle; (2) if the opening is not circular, the diameter or a circle of equivalent cross-sectional area.

EXISTING WORK.—A plumbing system or any part thereof installed prior to the effective date of this code.

FIRE LINE.—A system of pipes and equipment used exclusively to supply water for extinguishing fires.

FIXTURE.—See plumbing fixture.

FIXTURE BRANCH.—A water supply pipe connecting one or more fixtures to a main water supply header or riser.

FIXTURE DRAIN.—The drain from the trap of a fixture to the junction of that drain with any other drain pipe.

FIXTURE SUPPLY.—A water-supply pipe connecting the fixture with the fixture branch.

FLOOD LEVEL RIM.—The top edge or rim of a receptacle from which water can overflow regardless of the location of any overflow piping from the receptacle.

FLOODED.—A fixture is flooded when the liquid therein rises to the flood level rim.

FLUSH VALVE.—A device located at the bottom of the tank for the purpose of flushing water closets and similar fixtures.

FLUSHMETER VALVE.—A device that discharges a predetermined quantity of water to fixtures

Reference Standard 16

for flushing purposes and is actuated by direct water pressure.

FROSTPROOF WATER CLOSET.—A hopper that has no water in the bowl and has the trap and the control valve for its water supply installed below the frost line.

GAS DISTRIBUTION PIPING.—All piping from the house wide of the gas meter piping that distributes the gas supplied by a public utility to all fixtures and apparatus used for illumination or fuel in any building

GAS METER PIPING.—The piping from the shut-off valve inside the building to the outlet of the meter.

GAS SERVICE PIPING.—The supply pipe from the street main through the building wall and including the stopcock or shut-off valve inside the building.

INDIRECT WASTE PIPE.—A drain pipe used to convey liquid wastes that does not connect directly with the drainage system, but which discharges into the house drainage system through an air break into a trap, fixture, receptacle, or interceptor.

INDUSTRIAL WASTE.—A liquid, gaseous or solid substance, or a combination thereof resulting from any process of industry, manufacturing, trade or business or from the development or recovery of any natural resource.

INTERCEPTOR.—A device designed and installed so as to separate and retain deleterious, hazardous, or undesirable matter from normal wastes and permit normal sewage or liquid wastes to discharge into the disposal terminal by gravity.

LEACHING WELL OR PIT.—A covered pit constructed so as to permit the liquid contents to seep into the ground.

LEADER.—A vertical drainage pipe for conveying storm water from roof or gutter drains to the building storm drain, building house drain (combined), or other means of disposal. The leader shall include the horizontal pipe to a single roof drain or gutter drain.

LIQUID WASTE.—The discharge from any fixture, appliance, or appurtenance, in connection with a plumbing system that does not receive fecal matter.

LOAD FACTOR.—The percentage of the total connected fixture unit flow rate that is likely to occur at any point in the drainage system.

LOCAL VENTILATING PIPE.—A pipe on the fixture side of the trap through which vapor or foul air is removed from a room or fixture.

NORMAL SEWAGE.—Normal sewage means "normal sewage" as defined in the rules and regulations of the Department of Public Works.

PITCH.—See grade.

pH VALUE.—An arbitrary symbol adopted to express the degree of acidity or alkalinity of a solution. It is the logarithm of the reciprocal of the hydrogenion concentration, in gram mols per liter at 71.6°F. A pH of 7.0 represents a neutral solution, lower values represent acidity, higher values alkalinity.

PIPING.—As used in this reference standard, piping shall include fittings, valves, and other accessories or appurtenances required to make a complete installation.

PLUMBING.—The practice, materials, and fixtures used in the installation, maintenance, extension, repair, replacement, relocation and alteration of all piping, fixtures, appliances, and appurtenances in connection with any of the following, sanitary drainage or storm drainage facilities, the venting system, and public or private water supply systems, within or adjacent to any building; also, the practice and materials used in the installation, maintenance, extension, repair, replacement, relocation or alteration of storm water, liquid-waste, or sewerage, and water-supply systems of any premises in their connection with any point of public disposal or other acceptable terminal.

PLUMBING FIXTURES.—Installed receptacles, devices, or appliances that are supplied with water or that receive or discharge liquids or liquid-borne wastes.

PLUMBING SYSTEM.—Includes the water-supply and distribution pipes; plumbing fixtures and traps; soil, waste, and vent pipe; building house drains and building house sewers including their respective connections, devices, and appurtenances within the property lines of the premises, and water-treating or water-using equipment.

POOL.—A water receptacle used for swimming or as a plunge or other bath, designed to accommodate more than one bather at a time. Also a receptacle used for decorative purposes.

POTABLE WATER.—Water free from impurities present in amounts sufficient to cause disease or harmful physiological effects. Its bacteriological and chemical quality shall conform to the requirements of the department of health of the City of New York.

PRIVATE OR PRIVATE USE.—In the classification of plumbing fixtures, "private" applies to fixtures in residences and apartments and to fixtures in bathrooms of hotels and similar installations where the fixtures are intended for the use of a family or an individual.

PRIVATE SEWER.—A sewer privately owned and controlled by public authority only to the extent provided by law.

PUBLIC OR PUBLIC USE.—In the classification of plumbing fixtures, "public" applies to fixtures in general toilet rooms of schools, gymnasiums, hotels, railroad stations, public buildings, bars, comfort stations, and other installations (whether pay or free) where fixtures are installed so that their use is similarly unrestricted.

PUBLIC SEWER.—A common sewer directly controlled by public authority.

RELIEF VENT.—A vent installed so as to permit additional circulation of air between the drainage and vent systems where the drainage system might otherwise be air bound.

RIM.—An unobstructed open edge of a fixture.

Reference Standard 16

RISER.—A water-supply pipe that extends vertically one full story or more to convey water to branches or fixtures.

ROOF DRAIN.—A drain installed to receive water collecting on the surface of a roof and to discharge it into the leader (downspout).

ROUGHING-IN.—The installation of all parts of the plumbing system that can be completed prior to the installation of fixtures. This includes drainage, water-supply, and vent piping, and the necessary fixture supports.

SANITARY SEWAGE.—See domestic sewage.

SANITARY SEWER.—A pipe that carries sewage and excludes storm, surface and ground water.

SEEPAGE PITS OR WELLS.—A covered pit with open jointed or perforated lining into which the septic tank effluent is discharged. The liquid portion of the sewage seeps into the surrounding porous soil. The remaining solids or sludge is retained in the pit.

SEPARATOR.—See interceptor.

SEPTIC TANK.—A watertight receptacle that receives the discharge of a drainage system or part thereof, and is designed and constructed so as to separate solids from the liquid, digest organic matter during a period of detention, and allow the liquids to discharge into the soil outside of the tank through a system of open-joint or perforated piping, or seepage pit.

SEWAGE.—Any liquid waste containing animal or vegetable matter in suspension or solution, and may include liquids containing chemicals in solution.

SEWAGE DISPOSAL SYSTEM.—A system for the disposal of domestic sewage by means of a septic tank, cesspool, or mechanical treatment, all designed for use apart from a public sewer to serve a single establishment, building, or development.

SEWAGE EJECTOR.—A mechanical device used to pump or eject sewage.

SEWAGE EJECTOR PIT.—A tank or pit that receives sewage located below the normal grade of the gravity system and that must be emptied by mechanical means.

SIDE VENT.—A vent connecting to the drain pipe through a fitting at an angle not greater than 45 degrees to the vertical.

SLOPE.—See grade.

SOIL PIPE.—A pipe that conveys sewage containing fecal matter.

SPECIAL WASTE.—Waste which requires special treatment before entry into the normal plumbing system.

STACK.—A general term for any vertical line of soil, waste, vent, or inside leader piping. This does not include vertical fixture and vent branches that do not extend through the roof or that pass through not more than two stories before being reconnected to the vent stack or stack vent.

STACK VENT (SOMETIMES CALLED A

WASTE VENT OR SOIL VENT).—The extension of a soil or waste stack above the highest horizontal drain connected to the stack.

STACK VENTING.—A method of venting a fixture or fixtures through the soil waste stack.

STORM DRAIN.—See building storm drain.

STORM SEWER.—A sewer used for conveying rain water, surface water, condensate, cooling water, or similar clear liquid wastes.

SUB-HOUSE DRAIN.—See building sub-house drain.

SUB-SURFACE DISPOSAL FIELD.—A system of open jointed tile or perforated pipes or drains through which storm water or the sewage effluent from a septic tank is distributed beneath the surface of the ground for absorption into the soil, as well as evaporation into the air during favorable weather conditions.

SUB-SOIL DRAIN.—A drain that receives only sub-surface or seepage water and conveys it to a place of disposal.

SUMP PIT.—A tank or pit that receives clear liquid wastes, that do not contain organic materials or compounds subject to decomposition, located below the normal grade of the gravity system and which must be emptied by mechanical means.

SUMP PUMP.—A mechanical device used to eject or pump the liquid waste from a sump pit into the gravity drainage system.

SUPPORTS.—Devices for supporting and securing pipe, fixtures, and equipment.

SWIMMING POOL.—Any structure, basin, chamber or tank containing water for swimming, diving, or recreational bathing and having a depth of 2 ft. or more at any one point.

TRAP.—A fitting or device with a smooth interior passage, the inside diameter of which is equal to the inlet pipe diameter, and which provides a liquid seal of at least 2 in.

TRAP SEAL.—The maximum vertical depth of liquid that a trap will retain, measured between the crown weir and the top of the dip of the trap. Seal 2 in. in normal traps and 3 in. or more for deep seal traps.

VACUUM BREAKER.—A device used to prevent backflow by siphonic action.

VENT PIPE.—See vent system.

VENT STACK.—A vertical vent pipe installed primarily for the purpose of providing circulation of air to and from any part of the drainage system.

VENT SYSTEM.—A pipe or pipes installed to provide a flow of air to or from a drainage system or to provide a circulation of air within such system to protect trap seals from siphonage and back pressure.

VERTICAL PIPE.—Any pipe or fitting that is installed in a vertical position or that makes an angle of not more than 45 degrees with the vertical.

WASTE PIPE.—A pipe that conveys only

Reference Standard 16

liquid waste, free of fecal matter.

WATER-DISTRIBUTION PIPING.—In a building or premises, piping that conveys water from the water service pipe to the plumbing fixtures and other water outlets.

WATER (STREET) MAIN.—A water-supply pipe for public or community use controlled by public authority.

WATER OUTLET.—As used in connection with the water-distributing system, is the discharge opening for the water to a fixture; to atmospheric pressure (except into an open tank which is part of the water-supply system); to a boiler or heating system; to any water-operated device or equipment requiring water to operate, but not a part of the plumbing system.

WATER SERVICE PIPING.—That portion of the water supply system extending from the public street water main to the house control valve inside the building to a point where the supply is fully metered.

WATER SUPPLY SYSTEM.—Consists of the water-service pipe, the water-distribution pipes, and the necessary connecting pipes, fittings, control valves, and all appurtenances used for conveying water.

YOKE VENT.—A pipe connecting upward from a soil or waste stack to a vent stack for the purpose of preventing pressure changes in the stack.

Section P101.0 General Provisions

P101.1 Protection of Pipes.-

(a) **Breakage.**—Pipe passing under or through walls shall be protected from breakage. Any plumbing pipe passing under a footing or through a foundation wall shall be protected from carrying any weight of the structure by an arch or lintel constructed above the pipe by an iron-pipe sleeve built into the masonry wall and greater in size than the pipe passing through the wall, or by an equivalent method of protection.

(b) **Corrosion.**—Pipe subject to external corrosion by passing through or under corrosive material shall be protected against external corrosion by protective coating, wrapping, or other equivalent means that will resist such corrosion.

P101.2 Trenching, Excavation, and Backfill.-

(a) **Material for backfill.**—Trenches shall be backfilled by hand and tamped, in 6 in. layers, for 1 ft. above the crown of the pipe. Loose earth, free from frozen earth chunks or other material that may break the pipe, shall be used to provide firm bedding around the pipe.

(b) Trenching methods.-

(1) Trenches shall be excavated to a width sufficient to permit workmen to properly install the pipe. The bottom of the pipe trench shall be constructed so that the pipe between joints will have solid bearing along its entire length. Bell holes shall be provided at points where the

pipe is joined together to insure uniform bearing along the length of the pipe. In rock excavation the material shall be removed 3 in. to 6 in. below the grade line of the trench and then backfilled and tamped to grade with sand to provide a uniform firm foundation for the pipe. If soil materials of class 11-65 or poorer are encountered the pipe shall be supported in accordance with the applicable provisions of the building code for structural work.

(2) Where open trenches are impractical, pipe may be installed by driving or tunneling methods acceptable to the commissioner. Where driving or tunneling methods are employed, special care shall be exercised to protect the pipe from breakage and against earth settling or caving. Pipe may be installed in a previously driven conduit slightly larger than the pipe. Earth tunnels with a length not exceeding the depth of the trench may be employed, providing adequate supporting structures are provided to prevent future settling or caving.

(3) Permits for sidewalk and street openings shall be obtained from the department of highways.

P101.3 Sleeves.-

(a) The annular space between sleeves and pipe through foundation or exterior building walls shall be filled or partly caulked with polysulphide compound, lead, or other equivalent waterproofing material.

(b) Where pipes and sleeves pass through construction required to have a fire-resistance rating, they shall comply with the applicable requirements of the building code.

P101.4 Ratproofing.—In an apartment or in dwelling units, and in buildings or building areas used for the storage or preparation of food, the openings in walls, floors, or ceilings for the passage of pipes shall be closed and protected by metal collars securely fastened to the structure.

P101.5 Toilet Facilities for Workmen.—The site upon which any building, except a one- or two-family dwelling, is being constructed shall be provided with toilet facilities for use of workmen as specified in Table RS 16-5.

Section P102.0 Materials

P102.1 General Requirements.-

(a) **Materials required.**—All materials used in the construction of any plumbing system, fixtures, or equipment shall be as required by this reference standard.

(b) **Installation.**—All materials installed in plumbing systems shall be handled and installed so as to avoid damage to the material.

P102.2 Standards for Plumbing Materials.-

(a) **Materials.**—Materials shall conform to one of the standards cited in Table RS 16-1. Equivalent materials not listed in Table RS 16-1 may be used provided they are approved.

Reference Standard 16

*TABLE RS 16-1 STANDARDS FOR PLUMBING MATERIALS^a

Materials	ANSI	Other
Ferrous Pipe and Fittings-		
Cast iron soil pipe and fittings coupling...	None	CISPI 310-1985
Hubless cast iron soil pipe	None	CISPI 301-1985
Cast iron soil pipe and fittings, extra heavy and service weights	None	CS188-66
Cast iron water pipe	A21.6-1962 A21.8-1962	
Cast iron pipe, drainage, vent and waste...	None	FS-WW-P356-1936
Cast iron pipe, pressure (50 lb.) gas and water	None	FS-WW-P360a-1959
Cast iron (threaded) pipe	A40.5-1943	
Cast iron (threaded) fittings	B16.4-1963	
Cast iron drainage fittings	B16.12-1965	
Galvanized pipe and fitting	None	FS-WW-P406(1) 1945
Malleable iron fittings (threaded)		
150 lbs.	B16.3-1963	
300 lbs.	B16.3-1963	
Steel pipe, seamless and welded, black and zinc coated (not intended for close coiling)	B36.20-1966	
Steel pipe, seamless and welded, black and zinc coated (suitable for close coiling)	B36.1-1966	
Stainless steel pipe	B36.19-1965	
Union, malleable iron or steel	None	*FS-WW-O531a-1957 FS-WW-U536(1)-1953
Wrought-iron pipe	B36.2-1966	
Valves, cast iron, gate 125 and 250 lb. threaded and flanged	None	FS-WW-V58(1)-1946
Pipe fittings, bronze and ferrous (bushings, plugs and locknuts), threaded	None	FS-WW-P471(1)-1946
Nipples, pipe threaded	None	FS-WW-N351a-1956
Non-Ferrous Pipe and Fittings-		
Finished and rough brass plumbing fixture fittings	None	ASME A112.18.1M-79
Brass tube	H36.1-1967	
Brass pipe	H27.1-1963	
Brass or bronze flanges and flanged fittings, 150 and 300 lb.	B16.24-1962	
Brass or bronze screwed fittings, 125 lb and 250 lb.	B16.15-1964	
Cast-bronze solder joint pressure fittings	B16.18-1963	
Cast-brass solder joint drainage fittings	B16.23-1960	
Copper pipe	H26.1-1963	
Copper pipe, threadless	H26.2-1963	
Seamless copper tube	H23.3-1965	
Copper water tube, type K, L	H23.1-1967	
Wrought copper and wrought bronze solder joint fittings	H16.22-1963	

^aAs enacted but "FS-WW-U531a-1957" probably intended.

Reference Standard 16

Wrought copper and wrought copper alloy solder joint drainage fittings.....	H16.29-1966	
Lead pipe and traps	None	WW-P325-1944
Unions, brass or bronze, 250 lb.	None	FS-WW-U516-1933
Valves, bronze; angle, check and globe, 125 and 150 lb., threaded and flanged	None	FS-WW-V51a(2)-1954
Valves; bronze, gate, 125 and 150 lb., threaded and flanged	None	FS-WW-V54b-1962
Pipe fittings, bronze and ferrous (bushings, plugs and locknuts), threaded	None	FS-WW-P471(1)-1946
Non-Metallic Pipe and Fittings-		
Asbestos cement (sewer) pipe ^b	None	ASTM-C428-65T
Asbestos cement underdrain	None	ASTM-C508-67T
Clay drain tile	None	ASTM-C4-62
Concrete sewer pipe, reinforced	None	ASTM-C76-65T
Concrete sewer pipe, nonreinforced....	None	ASTM-C14-67
Clay sewer pipe, standard strength	A106.3-1965	ASTM-C13-64T
Vitrified clay sewer pipe, salt-glazed and unglazed extra strength.....	None	ASTM-C200-65T
Vitrified clay sewer pipe, ceramic glazed, extra strength	None	FS-SSP361b-1962
Vitrified clay sewer pipe, perforated, standard strength	A106.1-1962	
Plumbing Fixtures-		
Drinking fountains	Z4.2-1942	
Enameled cast iron plumbing fixtures..	None	ASME 112.19.1M-87
Earthenware (vitreous glazed) plumbing fixtures	None	CS111-43
Formed steel enameled sanitary ware..	None	FS-WW-P541b(2)-1962
Formed metal porcelain enameled sanitary ware	None	FS-WW-P541b(2)-1962
Heaters, water, instantaneous (steam-water converter type)	None	FS-WW-H191-1954
Plumbing fixtures (for) land use	None	FS-WW-P541b(2)-1962
Stainless steel plumbing fixtures	None	ASME A112.19.3M-87
Vitreous china plumbing fixtures	A112.19.2M-82	
Stills, water; portable (without heating device) for U.S.P." distilled water"....	None	FS-RR-S726(1)-1950
Porcelain enameled formed steel plumbing fixtures.	None	ASME A112.19.4M-84
Miscellaneous Materials and Standards-		
Automatic relief valves	Z21.22-1964	
Air gap standards	A40.4-1942	
Backflow preventers	A40.6-1943	
Brass cleanout plugs	None	*FS-WW-P401(3)-1951
Brazing filler metal	None	ASTM-B260-62T
Caulking lead, Type I	None	FS-QQ-L156(1)-1946
Caulking: lead wool and lead pig	None	FS-QQ-C40-1963
Cement lining	A21.4-1964	
Coal-tar, enamel, protective coating....	None	AWWA-C203-62

*As enacted but not applicable for this item.

Reference Standard 16

Fixture setting compound	None	FS-HH-C536a-1954
Flange dimensions, standard classes 125 and 250 cast iron flanges, classes 150, 250 and 300 bronze flanges (land use)	None	FS-WW-F406a(1)-1943
Galvanized iron and steel sheets	G8.2-1964	
Gaskets, plumbing-fixture-setting	None	FS-HH-G116-1936
Hangers and supports, pipe	None	FS-WW-H171b-1959
Resilient joints	None	ASTM-C425-64
Rubber gaskets (concrete sewer pipes).	None	ASTM-C443-65
Seal joints, sewer	None	FS-SS-S169-1954
Sheet brass, leaded and non-leaded	None	ASTM-B36-66 ASTM-B121-66
Sheet copper	None	ASTM-B152-60
Sheet lead, grade A	None	FS-QQ-L201d-1961
Solder metal	None	ASTM-B32-66T
Steel septic tanks	None	CS177-62
Domestic hot water heaters	Z21.10.1-1966	C72.1-1949

Notes-

**^a Abbreviations used in the table refer to the following organizations:

*** USASI—United States of America Standards Institute

ASTM—American Society for Testing and Materials

AWWA—American Water Works Association

CS—Commercial Standards

FS—Federal Specifications

**Local Law 100-1989; Local Law 29-1989; Local Law 63-1976*

***List as enacted, but probably intended to add "ASME-American Society of Mechanical Engineers."*

****As enacted, but probably intended to read "ANSI-American National Standards Institute, Inc."*

^b Asbestos cement building sewer pipe shall meet the requirements of ASTM Standard C428-63T expanded as follows:

- (1) Additional sizes 4 in. and 5 in.
- (2) No hydrostatic test for building sewer service
- (3) Flexural strength:

Size (in.)	Length (in.)	Class 1500	Class 2400	Class 3300
4	10	550	775	1100
4	13	750	1000	1350
5	10	950	1375	1900
5	13	1250	1775	2350
6	10	1500	1700	2100
6	13	2000	2200	2600

(4) Crushing strength: Include 4 in. and 5 in. for Classes 1500, 2400, 3300

Crushing test: One specimen from each 300 lengths of 4 in., 5 in., and 6 in. size pipes.

Reference Standard 16

†(b) **Plastic piping and fittings.**-Plastic piping and fittings may be used only in residential buildings of three stories or less in height, except that corrugated polyethylene piping with a diameter of twelve inches or more and plastic fittings may be used in connection with any type of building for underground yard drainage and storm water piping when used outside of the foundation walls of the building and not connecting to any piping system from the interior of the building and shall be approved. Plastic drain, waste and vent pipe and fittings used inside of residential buildings of three stories or less in height shall be required to conform with ASTM Standard D2661-97 Specification for Acrylonitrile-Butadiene-Styrene (ABS) Schedule 40 Plastic Drain, Waste, and Vent Pipe and Fittings or ASTM Standard D2665-98 Specification for Poly Vinyl Chloride (PVC) Plastic Drain, Waste, and Vent Pipe and Fittings, as well as the International Association of Plumbing and Mechanical Officials Installation Standards for ABS Building Drain, Waste and Vent Pipe and Fittings (IAPMO IS 5-92) and PVC Building Drain, Waste and Vent Pipe and Fittings (IAPMO IS 9-95) and Non-Metallic Building Sewers (IAPMO IS 1-91).

†*Local Law 2-2001; Local Law 58-1973; Local Law 75-1971*

P102.3 Identification of Materials.-Materials shall be identified as provided herein.

P102.4 Piping System Materials.-

(a) Water supply systems.-

*(1) **WATER SERVICE PIPE.**-Water service piping within the property line shall be of red brass or copper pipe; type K copper tube; type "TP" threadless copper; cast iron or ductile iron water pipe; or plastic pipe in accordance with section P102.2(b). Water service piping outside of the property line shall comply with requirements of the department of environmental protection. When used underground in corrosive soil or fill, all ferrous pipe and fittings shall be coal tar, enamel coated. Threaded joints shall be coated and wrapped after installation regardless of the nature of the soil.

(2) **WATER DISTRIBUTION SYSTEM PIPE.**-Water distribution system piping shall be of red brass pipe, type "TP" threadless copper pipe, hard temper type "K" copper tube, hard temper type "L" copper tube, galvanized wrought iron pipe, galvanized steel pipe, or ductile cast iron properly anchored. Cast iron and ductile-iron pipe may be cement lined in accordance with ANSI A21.4-1971. Type "L" copper tube shall not be installed in soil or concrete floor fill.

*** **(b) Drainage systems.**-

**Local Law 29-1987; Local Law 63-1976; Local Law 58-1973*

****Local Law 63-1976*

(1) **ABOVE GROUND PIPING WITHIN BUILDINGS.**-Soil, waste, and storm water or leader piping above ground in buildings shall be brass pipe, copper pipe,

hard temper type "K" copper tube, hard temper type "L" copper tube, extra heavy cast iron soil pipe, service weight cast iron soil pipe, no-hub cast iron soil pipe, AWWA class 22 or stronger iron, stainless steel pipe, threaded cast iron pipe, galvanized wrought iron pipe, galvanized steel pipe, or lead pipe, singly or in combination. Cast iron piping and fittings may be coated or uncoated. The maximum developed length to which lead may be used in connection with any one fixture shall be 5 feet. Plastic pipe will be permitted if it conforms to the requirements set forth in section P102.2(b).

(2) **UNDERGROUND PIPING WITHIN BUILDINGS.**-

All underground building drains shall be extra heavy cast iron soil pipe, service weight cast iron soil pipe, no-hub cast iron soil pipe, AWWA Class 22 or stronger cast iron water piping, ductile cast iron, brass pipe, type "K" hard temper copper tube, or plastic pipe conforming to the requirements set forth in section P102.2(b). Cast iron pipe and fittings may be coated or uncoated.

(3) **BUILDING HOUSE SEWERS.**-

** a. Building house sewers shall be extra heavy iron soil pipe and fittings, service weight cast iron soil pipe and fittings, no-hub cast iron soil pipe and fittings, AWWA class 22 or stronger cast iron water piping, ductile cast iron and fittings, or plastic pipe conforming to the requirements set forth in section P102.2(b), a minimum of 8 in. size in the borough of Manhattan and 6 in. in the other boroughs, except that a house sewer from one- and two-family dwellings may be the size specified in Table RS 16-13 and may run up to the street line. Cast iron pipe and fittings may be coated or uncoated.

***Local Law 58-1973; Local Law 39-1972*

b. Building house sewers for one- and two-family dwellings when installed in a separate trench from the water service may be of vitreous pipe or asbestos cement pipe.

c. Existing building sewers may be used in connection with a new building sewer and drainage system only when found by examination and test to conform to the new system in quality of material.

†(4) **UNDERGROUND YARD DRAINAGE AND STORM WATER PIPING.**-Underground yard drainage and storm water piping within the property line but outside of the foundation walls of the building shall be extra heavy cast iron soil pipe, AWWA Class 22 or stronger cast iron water pipe, ductile cast iron, service weight cast iron, no-hub cast iron soil pipe, asbestos cement pipe, vitreous tile pipe, concrete pipe, or plastic pipe conforming to the requirements set forth in section P102.2(b). Cast iron pipe and fittings may be coated or uncoated.

†*Local Law 63-1976; Local Law 58-1973*

(5) **CHEMICAL WASTES (ACID WASTES)**-

Separate drainage systems for chemical waste shall be of acid resistant material when the waste water at any point in the system will have a pH value of less than 4.5

Reference Standard 16

or more than 9.5. Chemical waste drainage piping shall be low expansion, borosilicate glass pipe; high silicon cast iron pipe; chemical stoneware pipe; chemical lead pipe; or approved plastic pipe regardless of building height, or other equivalent materials. Materials may be used singly or in combination.

***** (c) Venting Systems.-**

(1) ABOVE GROUND VENTING.-Vent piping installed above ground shall be brass pipe, type "TP" threadless copper pipe, hard temper type "K" copper tube, hard temper type "L" copper tube; extra heavy cast iron soil pipe, service weight cast iron soil pipe, no-hub cast iron soil pipe, AWWA Class 22 or stronger cast iron water pipe, ductile cast iron, threaded cast iron pipe, galvanized wrought iron pipe, galvanized steel pipe, singly or in combination. Cast iron pipe and fittings may be coated or uncoated. Plastic pipe will be permitted if it conforms to the requirements set forth in section P102.2(b).

****Local Law 63-1976*

(2) UNDERGROUND VENTING. Underground vent piping shall be extra heavy cast iron soil pipe, service weight cast iron soil pipe, no-hub cast iron soil pipe, AWWA Class 22 or stronger cast iron water pipe, ductile cast iron, brass pipe, copper pipe, or type "K" hard temper copper tube. Cast iron pipe and fittings may be coated or uncoated.

(3) CHEMICAL WASTE SYSTEMS.-Vent piping for chemical waste systems shall conform to the requirements for the chemical waste pipe.

(d) **Fittings.-**The materials of which water supply, drainage, and venting system pipe fittings are made shall conform to the type of piping material used in the water supply, drainage, or venting system (i.e., brass or bronze fittings with copper pipe or tubing), except that black cast iron may be used with brass or galvanized pipe. Threaded drainage pipe fittings shall be of the recessed drainage type. Fittings used to prevent or

reduce galvanic corrosion may be installed within a system only at the point of isolation.

(e) Other piping systems and miscellaneous materials.-

(1) ROOF DRAINS.-Roof drains shall be cast iron, bronze, copper, brass, stainless steel, lead, or other equivalent corrosion resistant material.

(2) EXTERIOR LEADERS (DOWNSPOUTS).-

Exterior leaders and gutters installed above ground level shall be sheet metal or copper, aluminum, galvanized steel, stainless steel, or other equivalent corrosion resistant material. Pipe (galvanized steel, galvanized wrought iron, cast iron or brass) may be used for the first 15 ft. of leader extending up from grade, providing that the pipe is securely anchored with offset clamps to the face of building at two points in the vertical section of pipe. Pipe will not be acceptable above 15 ft.

*(3) SUBSOIL DRAINS.-Subsoil drains shall be clay tile that is open jointed, horizontally split, or perforated; open jointed cast iron soil pipe; porous concrete pipe; asbestos cement pipe that is open jointed, horizontally split, or perforated or plastic pipe in accordance with section P102.2(b) that is open jointed, horizontally split, or perforated.

**Local Law 39-1972; Local Law 58-1973*

(4) LEAD BENDS AND TRAPS.-The walls of lead bends and traps shall be at least 1/8 in. thick.

(5) SHEET COPPER.-Sheet copper shall weigh at least 12 ounces per sq. ft.

(6) SHEET LEAD.-Sheet lead shall weight at least 4 psf.

(7) CAULKING FERRULES.-Caulking ferrules shall be brass or copper, and shall be made in accordance with Table RS 16-3.

Ferrules may be tapped "T" or tapped "Y" types with bossings provided on the tapped connection.

(8) SOLDERING BUSHINGS.-Soldering bushings shall be brass or copper in accordance with Table RS 16-4.

TABLE RS 16-3 CAULKING FERRULES

Pipe Sizes (In.)	Inside Diameter of Ferrule (In.)	Minimum Length of Ferrule (In.)	Minimum Weight of Each Ferrule
2	2 1/4	4 1/2	1 lb. - 0 oz.
3	3 1/4	4 1/2	1 lb. - 12 oz.
4	4 1/4	4 1/2	2 lbs. - 8 oz.

TABLE RS 16-4 SOLDERING BUSHINGS

Pipe Sizes (In.)	Minimum Weight of Each Ferrule
1 1/4	6 oz.
1 1/2	8 oz.
2	14 oz.
2 1/2	1 lb. - 6oz.
	2 lbs-. 0 oz.
4	3 lbs-. 8 oz.

Reference Standard 16

(9) FLOOR FLANGES.-Floor flanges for water closets or similar fixtures shall be of cast brass at least 1/8 in. thick, of cast iron at least 1/4 in. thick and having a caulking depth not less than 2 in., or of hard lead weighing at least 1 lb.-9 oz. and composed of lead alloy having at least 7.75 per cent antimony by weight. The use of floor flanges of other equivalent materials may be used.

(10) CLEANOUT PLUGS.-Cleanout plugs shall be of brass at least 1/8 in. thick and shall have raised square or hexagonal heads except that where raised heads will cause a tripping hazard, countersunk heads shall be used. Cleanout plugs of nylon may be used in exposed or accessible locations.

(11) FLUSH PIPES AND FITTINGS.-Flush pipes and fittings shall be of nonferrous material. When brass or copper tubing is used, the material shall be at least 0.0313 in. thick (no. 22 U.S. gage).

(12) TUBULAR BRASS TRAPS.-The "J" bend and wall tube shall be formed of brass tubing having a wall thickness of at least 0.045 in. (no.17 P & S gage) conforming to ASTM-B135-63, alloy No. 3. Bends shall be properly annealed after forming to prevent season-cracking. Nuts shall be cast brass conforming to ASTM-B146-52, alloy 6A, and the collars shall be cut from brass tubing conforming to ASTM B135-63, alloy No. 4. Collars shall be fully soldered on "J" bends.

*** (13) INSULATION.-Coverings and insulations, including vapor barriers, shall have a maximum flame spread rating of 25 without evidence of continued progressive combustion, and shall have a maximum smoke developed rating of 50. If the coverings and insulations, including vapor barriers are to be applied with adhesives, they shall be tested as applied with such adhesives, or the adhesives used shall have a maximum flame spread rating of 25 and a maximum smoke developed rating of 50. Tests shall be performed in accordance with ASTM-E84-61.

***Local Law 63-1976

(14) MISCELLANEOUS.-Internal and external parts of faucets, valves, ballcocks, etc. may be made with plastics meeting the criteria of this reference standard.

Section P103.0 Joints and Connections

*P103.1 Types of Joints for Piping Materials.-

*Local Law 13-1993

(a) **Asbestos cement pipe joints.**-Joints in asbestos cement pipe shall be made with sleeve couplings of the same composition as the pipe, and sealed with approved rings.

(b) **Brazed joints.**-Brazed joints for type "TP" threadless copper, copper, brass pipe, or copper water tube type "K" or "L" shall be made by first cleaning down to the base metal the surfaces to be welded or brazed, then applying a flux for such joints, and finally, making the joint with a brazing alloy having a melting point higher than 1000°F.

*** (c) **Cast iron pipe.**-Joints in cast iron pipe shall be compressed elastomeric, mechanical, caulked, or threaded,

or of another type as approved.

***Local Law 63-1976

*** (d) **Cast iron soil pipe.-**

(1) Caulked joints for cast iron bell and spigot soil pipe shall be firmly packed with oakum or hemp, filled with molten lead at least 1 inch deep and the surface shall not be depressed more than 1/8 inch below the rim of the hub. No paint, varnish, or other coatings will be permitted on the jointing material until after the joint has been tested and accepted. Lead shall be run in one pouring and shall be caulked tight.

(2) Mechanical joints for cast iron soil pipe shall be made with an approved preformed molded ring secured by pulling the pipe together in such a way as to compress the molded ring or shall be made with a corrosion resistant joint and clamp assembly surrounding a sealing sleeve of an approved elastomeric material so that the sealing sleeve is firmly compressed by the tightening device in the clamp assembly to provide a gas and water tight joint. Obstructions to the flow of water through a mechanical joint shall not be greater than those of a caulked joint.

***Local Law 63-1976

(e) **Cast iron water pipe (caulked joint).**-Caulked joints for cast iron bell and spigot water pipe shall be firmly packed with clean and sound asbestos rope, treated paper rope, or with molded or tubular approved rings. The remaining space in the hub shall be filled with molten lead according to the following schedule:

Pipe Size	Depth of Lead
Up to 20 in.	2 ¼ in.
24, 30, or 36 in.	2 ½ in.
Larger than 36 in.	3 in.

Lead shall be run in one pouring and shall be caulked tight.

*** (f) **Cast iron water pipe.**-Compression and mechanical joint.-

Mechanical joints in cast iron water pipe shall conform to ANSI A21.11-1972 and shall be made with a flanged collar, a ring gasket and appropriate number of securing bolts, or with a preformed molded ring secured by pulling the pipe together in such a way as to compress the molded ring. Mechanical joints may be used wherever AWWA cast iron or ductile iron is permitted in section P102.0.

***Local Law 63-1976

(g) **Clay sewer pipe.**-Joints in clay sewer pipe shall either be of hot poured compounds, or of preformed materials consisting of approved resilient materials that are installed on both the spigot and bell ends.

(h) **Concrete sewer pipe.**-Joints in concrete sewer pipe shall be of hot poured compound, of preformed material, or of approved gasketing rings.

(i) **Concrete pipe (slip joint).**-Flexible joints between lengths of concrete pipe may be made by using approved

Reference Standard 16

rubber materials on the spigot end and in the bell end of the pipe.

(j) Copper tube (type "K" or "L").—Joints in type "K" or "L" hard temper copper tube for water supply piping or drainage and vent piping shall be made by soldering or brazing. Solder shall be lead-free. Permissible lead-free solders are 95-5 tin-antimony, 96-4 tin-silver, 94-6 tin-silver, 95-5 tin-silver, or any other solder approved by the commissioner. Joints in copper tube for vent or drainage piping shall be made using cast brass or wrought copper solder joint drainage fittings. Tubing for water piping may be bent by mechanical means with no crushing or crimping of the tubing. For purposes of this section, lead-free solder shall mean solder containing less than 0.2 percent lead.

***Local Law 13-1993; Local Law 29-1987; Local Law 63-1976*

(k) Couplings.—All built-in threaded piping carrying gas or water shall be installed with couplings.

(l) Expansion joints.—Expansion joints must be accessible and shall be used only where necessary to provide for expansion and contraction of the pipes. All expansion joints shall be of type and material suitable for use with the type of piping in which they are installed.

(m) Hot poured joints.—All surfaces of the joint shall be cleaned and dried before pouring. Hot poured compound for clay or concrete sewer pipe shall not be water absorbent, and when poured against a dry surface, shall have a bond to withstand a pressure of at least 100 psi. If wet surfaces are unavoidable, a suitable primer shall be applied. The compound shall not soften sufficiently to destroy the effectiveness of the joint when subjected to a temperature of 160° F., nor shall it be soluble in any of the waste carried by the drainage system. Approximately 25 percent of the joint space at the base of the socket shall be filled with jute or hemp. A pouring collar, rope, or other device shall be used to hold the hot compound during pouring. Each joint shall be poured in one operation until the joint is filled. Joints shall not be tested until at least 1 hr. after pouring.

(n) Glass pipe joints.—Joints in chemical waste glass piping shall be made with approved compression coupling, adapter coupling or adjustable joints.

(o) Preformed joints.—Preformed collars shall be formed in both the spigot and bell of the pipe in advance of closing the joint. Collar surfaces shall be conical with side slopes of 3 degrees with respect to the axis of the pipe, and the length shall be equal to the depth of the bell socket. Prior to making joint contact, surfaces of collars shall be cleaned and coated with solvents and adhesives. When the spigot end is inserted in the collar of the bell end, it shall bind before reaching the base of the socket. Collar material shall be inert and resistant to both acids and alkalis.

(p) Slip joints.—Slip joints in expansion joints will be permitted. Slip joints shall be made with packing or gasket material or with ground joint brass compression rings. Ground joint brass connections that allow adjustment of tubing but provide a rigid joint when made up shall not be

considered as slip joints. Slip joints will be permitted between the stop valve and faucet connection but the stop and pipe size shall not be less than required pipe size indicated for the fixture by Table RS 16-7, but not less than 3/8 inch size nor longer than 18 inches from stop to faucet. Slip joints will be permitted between a tubular fixture trap and the sanitary waste.

****Local Law 63-1976*

(q) Soldered joints.—Soldered joints for type "K" or type "L" tube shall be made with fittings. Soldered joints shall be lead-free, as defined in subdivision (j).

***Local Law 13-1993; Local Law 29-1987; Local Law 63-1976*

(r) Threaded joints.—Threaded joints shall conform to American national taper thread, USASI-B2.1-1960 or FS-GGG-P351a. All burrs shall be removed. Pipe joint cement and paint shall be used only on male threads.

(s) Threadless copper pipe.—Joints in threadless copper pipe for water supply piping shall be made by brazing.

(t) Unions.—Unions shall have metal-to-metal ground seats, and their material shall conform to the type of piping in which they are installed.

(u) Wiped joints.—Joints in lead pipe or fittings, or between lead pipe or fittings and brass or copper pipe, ferrules, solder nipples, or traps, shall be full wiped joints. A wiped joint shall have an exposed surface of at least 3/4 in. on each side of the joint and a minimum thickness of 3/8 in. at its thickest part.

P103.2 Joints Between Different Piping Material-

(a) Cast iron and copper tube.—Joints between cast iron and copper tube shall be made either by directly caulking the copper tube in to the bell of the cast iron pipe or by using a brass caulking ferrule and properly sweating the copper tube to the ferrule.

(b) Cast iron and vitrified clay.—Joints between cast iron pipe and vitrified clay pipe shall be made either of hot poured bitumastic compound or by a preformed bituminous ring. This ring shall after ramming, completely fill the annular space between the cast iron spigot and the vitrified clay hub.

(c) Copper tube and threaded pipe.—Joints between copper tube and threaded pipe shall be made with brass adapter fittings. The connection between the copper tube and the fitting shall be properly brazed or soldered, and the connection between the threaded pipe and the fitting shall be made with a standard pipe size screw joint.

****Local Law 63-1976*

(d) Threaded pipe and cast iron pipe.—Joints between threaded pipe and cast iron pipe shall be either caulked or threaded, or shall be made with adapted fittings. Threaded piping shall include wrought iron, steel, brass, or copper pipe.

(e) Lead and cast iron, wrought iron, steel, copper or brass pipe.—Joints between lead and cast iron, wrought iron, steel, and copper or brass pipe shall be made by means of wiped joints to a caulking ferrule, soldering nipple, or bushing, or by means of a soil pipe adapter soldered to the copper tube.

(f) Asbestos-cement pipe to metal.—Joints between

Reference Standard 16

asbestos-cement pipe and metal shall be made by means of an adapter coupling which shall be installed as required for cast iron soil pipe.

P103.3 Connections Between Drainage Piping and Certain Fixtures.-Connections between drainage pipe and water closets, floor outlet service sinks, pedestal urinals, earthenware trap standards, or any other fixture with floor outlets, shall be made by means of brass, cast iron or other flanges that are caulked, soldered, or screwed to the drainage pipe. The connection shall be bolted, with a gasket or washer set between the earthenware and the connection. The gasket or washer shall not absorb moisture, break down, or lose its shape when immersed in 160°F water for 5 minutes. The floor flange shall be set on a waterproof, firm base with no rough edges at the hole for drain connection.

P103.4 Tightness.-Joints and connections in the plumbing system shall be made gastight and watertight for the pressure prescribed in the applicable test requirements, with the exceptions of those portions of perforated or open joint piping that are installed underground for the purpose of collecting and conveying ground or seepage water to the storm drains.

P103.5 Waterproofing.-Joints between piping and roof shall be made watertight by the use of lead, copper, aluminum, or other equivalent flashings or flashings material. Exterior wall openings shall be made watertight.

P103.6 Other joints.-Equivalent methods and materials for making pipe joints may be used if approved.

Section P104.0 Plumbing Fixtures

P104.1 Requirements.-

(a) Minimum number of fixtures.-The number of plumbing fixtures required for an occupancy shall be as listed in Table RS 16-5. The requirements for an occupancy not listed in the table shall be subject to approval by the Commissioner.

(b) Facilities for each sex.-Where public toilet or bathing facilities are designed for use by more than one person at a time, separate facilities shall be installed for each sex.

**** (c)** In every building where public toilet facilities are provided, there shall be at least one water closet stall for each sex which is accessible to the physically handicapped, at least 3 ft. wide by 5 ft.-6 in. in depth, having a door (if used) that is 32 in. wide and swings out to accommodate a wheelchair. The water closet set*** shall be set 17 to 19 in. above the floor. The stall shall be provided with grab bars on each side, the grab bars shall have an outside diameter of 1 1/2 in., and shall be 33 to 36 in. above and parallel to the floor, with 1 1/2 in. clearance from the wall. One drinking fountain facility, not of the recessed type, shall be provided. The provisions of reference standard RS 4-6 shall supplement the foregoing requirements.

(d) Accessibility.-The fixtures specified in Table RS 16-5 for public buildings shall be located not more than one floor above nor more than one floor below the floor occupied by the people for whose use the fixtures are intended, unless elevator service is available except that in buildings classified in occupancy group E which are accessible to the physically handicapped, there shall be at least one such toilet stall for male and one for female for every 300 occupants of each sex in the building.

****Local Law 58-1987**

*****As enacted, but "seat" probably intended.**

†P104.2 Installation of Fixtures.-

(a) No person shall install any plumbing fixture unless:
(1) such fixture meets the water saving performance standards and product labeling requirements provided in paragraphs b and c of this subdivision; and

(2) such fixture meets the standards as provided for in table 16-1; and

(3) i. the manufacturer has furnished to the commissioner, in such form as the commissioner shall determine, the identification and performance specifications of such fixture, and a certification that such fixture meets the standards as provided for in this section, and the commissioner has included such fixture on the list published pursuant to paragraph d of this subdivision or

ii. such fixture is included on the "list of certified water saving plumbing fixtures" published pursuant to section 15-0314 of the environmental conservation law; however this option shall not apply to water closets and associated flush valves on and after January first, nineteen hundred ninety-two which shall be certified to the commissioner pursuant to item i. of this subparagraph three.

(b) The water-saving performance standards for sink and lavatory faucets, shower heads, drinking water fountains, urinals and water closets shall be as follows:

(1) for sink and lavatory faucets, a constant water pressure of sixty pounds per square inch, and a maximum flow not to exceed three gallons of water per minute; faucet models installed in public buildings or facilities must be of a self-closing variety and shall comply with reference standard RS 4-6;

(2) for shower heads, a constant water pressure of sixty pounds per square inch, and a maximum flow not to exceed three gallons of water per minute;

(3) for urinals and associated flush-valves, if any, each flush shall not exceed one gallon of water per flush;

(4) for water closets and associated flush-valves, if any, each flush shall not exceed three and one half gallons of water per flush except that on and after January first, nineteen hundred ninety-two, each flush shall not exceed one and three-fifths gallons of water per flush; and

(5) drinking water fountains shall be of a self-closing variety and shall comply with reference standard RS 4-6.

(c) Permanent product markings shall be required on all water closets and urinals, or each fixture component if the fixture is comprised of more than one component, located in an easily recognizable location. Such markings

Reference Standard 16

shall be legible, applied so as to be permanent and provide the following information:

- i. the manufacturer's name or registered trademark and the model number of the fixture or fixtures; and
- ii. the gallon/liter water consumption rate per flush of the water closet or urinal; and
- iii. with respect to tank type water closets, a clear marking of and designation for the "water line" shall be located within the tank which shall be set at the level of gallons/liters per flush required for the water closet.

(d) The commissioner shall annually publish a list of fixtures which meets the standards specified in paragraph b of this subdivision which are certified by manufacturers pursuant to i. of subparagraph three of paragraph a and which are not included on the "list of certified water saving fixtures" published pursuant to section 15-0314 of the environmental conservation law. A notice of the availability of such list shall be published in the city record. The commissioner shall delete from such list fixtures which are determined to be inaccurately certified.

(e) The provisions of this subdivision shall not apply to fixtures such as safety showers and aspirator faucets, which in order to perform a specialized function, cannot meet the standards specified in paragraph b of this subdivision.

(f) Access for cleaning.-Plumbing fixtures shall be so installed as to afford easy access for cleaning both the fixture and the area about it. All pipes from fixtures shall be run to the nearest wall, except where it is impractical to do so.

(g) Sealing.-Where fixtures come in contact with wall or floors, the space between the fixture and the wall shall be sealed against water seepage.

(h) Securing floor outlet fixtures.-Floor outlet fixtures shall be rigidly secured to the floor or floor flanges by stainless steel, acetyl plastic, or non-ferrous screws or bolts.

(i) Securing wall-hung bowls.-Wall-hung water closet bowls shall be rigidly supported by a concealed metal supporting member so that no strain is placed on the closet connection.

(j) Water supply protection.-The supply lines or fittings for every plumbing fixture shall be so installed as to prevent backflow. See Section P107.0.

†*Local Law 29-1989*

P104.3 Overflows.-

(a) Design of overflows.-In any fixture that is provided with an overflow, the waste outlet shall be designed and installed so that the standing water in the fixture cannot rise in the overflow when the stopper is closed, nor shall any water remain in the overflow when the fixture is empty.

(b) Connection of overflows.-The overflow from any fixture shall discharge into the drainage system on the inlet or fixture side of the trap. The overflow from a flush tank serving a water closet or urinal shall discharge into the fixture served.

†P104.4 Water Closets.-

(a) Prohibited water closets.-

- (1) Washout, pan, valve, plunger, offset, latrine, and

side spud water closets shall be prohibited. Water closets that have an invisible seal, an unventilated space, or walls that are not thoroughly washed at each discharge, shall be prohibited. Any water closet that might permit a siphonage of the contents of the bowl back into the water supply system shall be prohibited.

(2) Frostproof water closets will be permitted by the commissioner for temporary installations only.

(b) Water closets for public use.-Water closet bowls for public use shall be of the elongated type.

(c) Water closets for children's use.-In nurseries, schools, and similar places where plumbing fixtures are provided for the use of children under six years of age, water closets shall be of a size and height suitable for the children's use.

(d) Water closet seats.-Water closets shall be equipped with seats of smooth nonabsorbent material. All seats of water closets provided for public use shall be the open-front type. Integral water closet seats shall be of the same material as the fixture.

(e) Water closet soil pipe connections.-

(1) **LEAD CONNECTIONS.**-Lead bends and stubs may be used on water closets or similar connections, provided the lead is soldered to the floor flange.

(2) **IRON CONNECTIONS.**-3 in. iron bends may be used on water closets or similar connections, provided a 4 in. x 3 in. flange is used to receive the fixture horn.

(3) **COPPER CONNECTIONS.**-3 in. copper bends may be used on water closets or similar connections, provided a 4 in. x 3 in. flange is used to receive the fixture horn.

(4) **OTHER TYPE CONNECTIONS.**-Connections of other equivalent materials will be permitted.

(5) **REDUCING BENDS.**-4 in. x 3 in. reducing bends may be used.

†*Local Law 29-1989*

P104.5 Urinals.-

(a) Prohibited urinals.-

(1) Floor-type trough urinals are prohibited.

(2) Washdown or washout type urinals that have integral strainers are prohibited.

(b) Wall-hung trough urinals.-Wall-hung trough urinals shall be permitted only in temporary locations. They shall be at least 6 in. deep and shall be furnished with one-piece backs and have strainers with outlets at least 1 1/2 in. in diameter. The washdown pipe shall be perforated so as to flush with an even curtain of water against the back of the urinal. This pipe shall be securely clamped as high as practicable to the back of the urinal. Trough urinals shall have tanks with a flushing capacity of at least 1 1/2 gal. of water for each 2 ft. of urinal length. Troughs shall be figured on the basis of one urinal for each 18 in. of length; e.g.,

24 in. trough equals 1 urinal
36 in. trough equals 2 urinals
48 in. trough equals 2 urinals
60 in. trough equals 3 urinals
72 in. trough equals 4 urinals

Reference Standard 16

(c) **Surrounding material.**-Wall and floor space to a point 1 ft. in front of a urinal lip and 4 ft. above the floor, and at least 1 ft. to each side of the urinal shall be finished with smooth, readily cleanable, nonabsorbent material.

P104.6 Flushing Devices for Water Closets and Urinals.-

(a) **Where required.**-Each water closet, urinal, clinical sink, or other plumbing fixture that depends on trap siphonage to discharge its waste contents to the drainage system to which it is connected, shall be provided with a flushometer valve, flush tank, or similar device designed and installed so as to supply water in sufficient quantity and rate of flow to flush to the sewer the contents of the fixture to which it is connected, to cleanse the fixture, and to refill the fixture trap in a single flushing operation.

(b) **Number of fixtures served.**-A flushing device shall serve only one fixture except that a single flushing device may be used to flush more than one urinal when it is designed so that the flushing cycle is controlled automatically and so that each urinal or section thereof is thoroughly flushed.

(c) **Flushometer valves.**-Flushometers shall be installed so that they will be readily accessible for repair. Flushometer valves shall not be used where the water pressure is insufficient to properly operate them. When the valve is operated, it shall complete the cycle of operation automatically, opening fully and closing positively under the water line pressure. Each flushometer shall be provided with a means for regulating the flow through it. Each flushometer valve supplying a submerged inlet without a required air gap shall be provided with an approved vacuum breaker set at least 4 in. above the overflow rim of the fixture to the critical level marked on the vacuum breaker as determined by test.

(d) Flush tanks.-

(1) **WATER SUPPLY.**-An adequate supply of water shall be provided to flush and clean the fixture served. The water supply to flush tanks equipped for automatic flushing shall be controlled by a suitable timing device. The water supply to flush tanks equipped for manual flushing shall be controlled by a float valve or other automatic device designed to refill the tank after each discharge and to completely shut off the water flow to the tank when the tank is filled to operational capacity. Provision shall be made to provide an adequate supply of water to the fixture so as to refill the trap seal after each flushing.

(2) **BALL COCKS.**-Ball cocks in flush tanks for water closets shall be located at least 1 in. above the flood level rim of the bowl connected thereto, and shall be provided with a vacuum breaker.

(3) **OVERFLOWS.**-Flush tanks shall be provided with overflows discharging to the water closet or urinal connected thereto, and shall be of sufficient size to

prevent flooding the tank at the maximum rate at which the tanks are supplied with water.

P104.7 Lavatories.-

(a) **Waste outlets.**-Lavatories shall have waste outlets at least 1 1/4 in. in diameter.

(b) **Multiple-type fixture.**-Each 18 in. unit of usable length of a straight-line type multiple-use lavatory and each 18 in. of usable length of a circular type multiple use lavatory shall be considered equivalent to one lavatory for the purpose of determining the drainage and water supply piping sizes and fixture usage requirements provided hot and cold or tempered water suitable for handwashing is available for each 18 in. interval.

P104.8 Bathtubs.-

(a) **Waste outlets and overflows.**-Bathtubs shall have waste outlets and overflows at least 1 1/2 in. in diameter, and the waste outlet shall be equipped with a suitable stopper.

P104.9 Showers.-

(a) **Waste outlet.**-Waste outlets serving single showers, other than those in bathtubs, shall be at least 2 in. in diameter, and when serving a gang shower shall be at least 3 in. in diameter. Drains shall have removable strainers with a free area no smaller than the cross-sectional area of the drain pipe connected thereto and openings no smaller than 1/4 in. in minimum dimension. Unless each shower head is provided with an individual waste outlet, the waste outlet must be so located and the floor so pitched that waste water from one shower head does not flow over the floor area serving another shower head.

(b) **Shower compartments.**-Shower compartments shall have at least 900 sq. in. of floor area and shall be at least 30 in. in minimum dimension measured as the side of a rectangle, altitude of a triangle or other angular shape, or as diameter of a circle, except when a bathtub is used as the shower compartment. The wall area above built-in tubs having installed shower heads and in shower compartments shall be constructed of smooth, noncorrodible, nonabsorbent, waterproof materials to a height of at least 6 ft. above the floor level. Such walls shall form a watertight joint with each other and with either the tub, receptor, or shower floor.

(c) **Shower floors or receptors.**-Floors or receptors under shower compartments shall be laid on a smooth and structurally sound base. Floors under shower compartments, other than those laid directly on the ground surface or where prefabricated receptors have been provided, shall be lined and made watertight by the provisions of suitable shower pans of durable material. Such pans shall turn up on all sides at least 2 in. above the finished shower floor level. Pans shall be securely fastened to the waste outlet at the seepage entrance, making a watertight joint between the pan and the outlet. Floor surfaces shall be constructed of smooth, noncorrodible, nonabsorbent, and waterproof materials.

Reference Standard 16

P104.10 Sinks.-

(a) **Waste outlets.**-Sinks shall be provided with waste outlets at least 1 1/2 in. in diameter.

(b) **Food waste disposals.**—Sinks equipped with food waste disposals shall have waste outlets at least equal to the opening in the disposals.

**Local Law 74-1995*

P104.11 Dishwashing Machines.-

(a) **General.**-A separate trap shall be provided for a dishwashing machine that drains by gravity.

(b) **Domestic machines.**-Machines having drainage pumps may discharge into the waste outlet piping of an adjacent kitchen sink by means of a wye branch fitting on the inlet side of the sink trap, provided the pump discharge line rises to an elevation above the flood level rim of the sink and is at least 3/4 in. in diameter.

(c) **Water connections.**-Water connections to a dishwasher shall be provided with an air gap or an approved vacuum breaker and check valve.

(d) **Commercial dishwashers.**-Commercial dishwashing machines shall be provided with an adequate supply of 140°F to 160°F wash water, and with rinse water or steam at temperature of at least 180°F for sterilization. Chemical disinfection may be used in lieu of the 180°F water or steam when the method of disinfection meets the requirements of the department of health.

P104.12 Automatic Clothes Washers.-

(a) The water supplies to an automatic clothes washer shall be protected against the hazards of contamination by means of an adequate air gap or a vacuum breaker.

(b) The discharge waste pipe of domestic clothes washers shall be provided with an air break by spilling the discharge into an open standpipe that is provided with a 2 in. trap. The trap shall be properly vented or connected to an indirect waste pipe that may be common to other automatic clothes washers located in a common laundry room.

(c) The discharge waste pipe of commercial clothes washers shall discharge into a trench provided with trapped and vented drains.

P104.13 Laundry Trays.-Each compartment of a laundry tray shall be provided with a waste outlet at least 1 1/2 in. in diameter.

P104.14 Garbage Can Washers.-

(a) The drain outlet receiving the wash from garbage cans shall be at least 3 in. and shall be provided with a removable basket or strainer to prevent discharge of large particles into the building drainage system.

(b) Water supply connections shall be provided with an air gap or an approved backflow prevention device and check valve.

P104.15 Fixture strainers.-Plumbing fixtures except water closets, urinals, or similar fixtures shall be provided with durable crossbars, strainers, or other similar devices installed in the fixture waste outlet. Such strainers shall have waterway areas adequate for rapid fixture drainage.

*P104.16 Drinking Fountains.-

(a) **Construction.**-Drinking fountains shall conform to **ASA-Z4.2-1942.

(b) **Equivalent fixtures.**-A lavatory located in a room with not more than one water closet or urinal will be an acceptable equivalent for a drinking fountain for the purpose of fixture requirements.

(c) **Prohibited drinking fountains.**-No electric coolers that have precooling coils inside of the waste outlets will be permitted except as hereinafter provided. The precoolers must be of double wall construction and mounted in a vertical position directly below a removable strainer in the cooler top and the precooler shall be fully accessible for cleaning with an ordinary bottle brush. Except for a water spreader at the entrance of the precooler drain tube, no internal dimension of the drain passage shall be less than 3/4 in.

** This title not enacted but probably intended.*

*** As enacted but "ANSI-Z4.2-1942." probably intended.*

P104.17 Floor Drains.-

(a) **Location.**-The floor drain shall be located so as to be readily accessible at all times.

(b) **Strainers.**-Floor drains shall be provided with removable strainers, the open area of which shall be at least equal to the cross-sectional area of the drain pipe to which the drain connects. Combination funnel and floor drain strainers will be permitted.

(c) **Size.**-Floor drains shall be of a size to efficiently serve the purpose for which they are intended, but the outlet pipe shall not be less than 3 in. in nominal diameter.

(d) **Provision for evaporation.**-Traps for floor drains shall be of the deep seal type, and shall have a water supply available from a plumbing fixture located in the same room or from a faucet or valved outlet located not more than 3 ft. above the floor drained. Automatic priming devices will be permitted only when an air gap is provided between the potable water supply and the water supply for the drain.

(e) **Traps.**-Machinery or equipment room floor drains that receive clear water only may be connected to a single trap where such trap is located not more than 15 ft. from the farthest drain.

P104.18 Drains for Drip Pipes. -See section P108.11.

P104.19 Funnel Drains.-When the trap is located above the floor, the funnel drain shall be individually vented. Funnel drains shall only be used for clear water wastes.

P104.20 Special Plumbing Fixtures.-

Reference Standard 16

(a) **Water connections.**-Baptisteries, ornamental and lily pools, aquaria, ornamental fountain basins, swimming pools, and similar constructions, when provided with water supplies, shall be protected from back-siphonage in conformity with the code requirements.

(b) **Approval.**-Specialties requiring water and waste connections shall be subject to approval by the Commissioner.

Section P105.0 Traps and Cleanouts

P105.1 Fixture Traps.-

(a) **Separate traps for each fixture.**-Each plumbing fixture shall be separately trapped by a water seal trap placed as close as possible to the fixture outlet, but not more than 2 ft. horizontal developed length from the outlet of the fixture. The vertical distance from the fixture outlet to the trap weir shall not exceed 48 in. No fixture shall be double trapped. Exceptions to the separate trapping requirements are as follows:

(1) Fixtures having integral traps.

(2) A combination plumbing fixture may be installed on one trap provided one compartment is not more than 6 in. deeper than the other and the waste outlets are not more than 30 in. apart, and provided the trap is centrally located between the waste outlets.

(3) One trap may be installed for a three compartment sink, three single laundry trays, or a combination of one sink and two trays immediately adjacent to each other in the same room, provided the trap is centrally located between the three sections.

(4) A domestic dishwasher located with a developed length of drain not more than 3 ft.-6 in. from the trap serving a kitchen sink or combination sink and tray may be connected to the fixture side of the sink trap. A dishwasher may also be connected as stated in section P104.11(b).

(5) No trap need be provided at fixtures and equipment that discharge their wastes indirectly into a trapped receptacle through a drainage pipe not exceeding 8 ft. in developed length, measured from the drainage outlet. No traps shall be provided for safety relief apparatus, condenser blow-offs, and similar drain lines.

(b) **Fixture trap sizes.**-Fixture trap sizes (nominal diameter) shall be sufficient to drain the fixture rapidly and in no case less than the sizes given in Table RS 16-6. No trap shall be larger than the drainage pipe into which it discharges.

(c) **Prohibited traps.**-The following types of traps are prohibited:

(1) Traps that depend upon moving parts to maintain their seal.

(2) Bell, pot, bottle traps, and traps with interior partitions.

(3) Crown vented traps.

(4) Traps constructed of masonry.

(5) Catch basins located within the building.

(d) **Design.**-All fixture traps, except grease and sediment interceptors, shall be self-scouring. Traps integral with

the fixtures shall have a uniform interior and smooth waterway. Traps shall have no interior partitions except where such traps are integral with the fixture or are designed as interceptors. Slip joints or couplings may be used on the inlet side of the trap and a ground joint union connection may be installed in the trap seal.

(e) **Seals.**-Each fixture trap shall have a liquid seal of at least 2 in. but not more than 4 in.

(f) **Setting and protection.**-Traps shall be set level with respect to their water seals and, where necessary, shall be protected from freezing and evaporation.

*****P105.2 Building (House) Traps.**-Shall be installed on all building drains near the foundation wall of the structure, inside of the street line, and on the sewer side of all connections, except the connection used to receive the discharge from a sewage ejector, oil separator or leader on combined systems. If such trap is placed outside of the foundation wall or below a cellar floor, it shall be made accessible in a manhole with a cover, or by extension of the two handholes that shall be provided with cleanouts at the cellar floor or grade. Handhole extensions shall be not more than 18 in. above the centerline of the drain. Building (house) traps shall be the same size as the building house drain connected thereto. Where manufactured cast iron traps are not available AWWA cast iron water pipe or ductile iron may be used for house traps if the trap is made with long turn fittings and TY's.

****Local Law 63-1976*

Reference Standard 16

***TABLE 16-5 MINIMUM NUMBER OF PLUMBING FIXTURES REQUIRED^a**

Type of Building Occupancy	TYPE OF FIXTURE							
	Water Closets		Urinals	Lavatories		Bathtubs or Showers	Drinking Fountains	Other Fixtures
Assembly – places of worship ^b	1 for each sex for each 150 persons		Urinals may be provided in toilet rooms in lieu of water closets but for not more than 1/2 of the required number of water closets	1				
Assembly – other than places of worship (including but not limited to auditoriums, theaters, convention halls) and all spaces classified as F-4	No. of Persons	No. of Fixtures for each Sex	Urinals may be provided in toilet rooms in lieu of water closets but for not more than 1/2 of the required number of water closets	No. of Persons	No. of Fixtures		1 for each 1,000 persons except that there shall be at least 1 fixture at each assembly floor, level or tier	Where motion picture projection booths contain more than 2 projectors, at least 1 water closet and 1 lavatory shall be provided on the same level and within 20 ft. of the booth
	1-100	1		1-200	1			
	101-200	2		201-400	2			
	201-300	3		401-750	3			
	301-400	4		Over 750, add 1 fixture for each 500 persons				
	Over 400, add 1 fixture for each additional 200 persons							
Dormitories – schools or labor, also institutional	1 for each sex for each 8 persons		Urinals may be provided in toilet rooms in lieu of water closets but for not more than 1/2 of the required number of water closets	1 for each 12 persons		1 for each 8 persons: for women’s dormitories, 1 bathtub shall be substituted for 1 shower at the ratio of 1 for each 30 women		Laundry trays – 1 for each 50 persons
Single room occupancies for sleeping accommodations only	1 for each 6 persons			1 for each 6 persons		1 for each 6 persons		
Dwellings- one- and two-family	1 for each dwelling unit			1 for each dwelling unit		1 for each dwelling unit		Kitchen sink— 1 for each dwelling unit
Public buildings, offices, business mercantile, storage; warehouses, factories and institutional employees ^c	No. of Persons for each sex	No. of Fixtures	Urinals may be provided in toilet rooms in lieu of water closets but for not more than 1/2 of the required number of water closets when more than 35 persons	No. of Persons	No. of Fixtures		1 for each 75 persons	
	1-15	1		1-20	1			
	16-35	2		21-40	2			
	36-55	3		41-60	3			
	56-80	4		61-90	4			
	81-110	5		91-125	5			
	111-150	6		1 fixture for each additional 45 persons				
Public bathing	1 fixture for each sex for each 30 persons		Urinals may be provided in toilet rooms in lieu of water closets but for not more than 1/2 of the required number of water closets	1/60		1/40		

Reference Standard 16

***TABLE 16-5 MINIMUM NUMBER OF PLUMBING FIXTURES REQUIRED^a (Continued)**

Type of Building Occupancy	TYPE OF FIXTURE						
	Water Closets	Urinals	Lavatories		Bathubs or Showers	Drinking Fountains	Other Fixtures
Schools: Elementary Secondary	1 fixture for each sex for each 35 students	Urinals may be provided in toilet rooms in lieu of water closets but for not more than 1/2 of the required number of water closets	1/50 pupils 1/50 pupils Over 300 pupils 1/100 pupils		In gym or pool shower rooms, ¼ pupils of the largest class using pool at any one time	1/50 persons but at least 1 per floor	
Workers portable facilities	1/30 workers	1/30 workers				At least 1 per floor equivalent for each 100 workmen	
Industrial - foundries only	No. of Persons No. of Fixtures 1-10 1 11-25 2 26-50 3 51-80 4 81-125 5 1 additional fixture for each additional 45 persons	Where more than 10 men are employed: No. of Men ^c No. of Urinals 11-29 1 30-79 2 1 additional fixture for each additional 80 males. Urinals may be provided in toilet rooms in lieu of water closets but for not more than ½ of the required number of water closets	No. of Persons No. of Fixtures 1-8 1 9-16 2 17-30 3 31-45 4 46-65 5 1 additional fixture for each additional 25 persons		1 shower for each 15 persons exposed to excessive heat or occupational hazard from poisonous, infectious, or irritating material	1 for each 75 persons	
Hospital and Institutions, See Section P114.0							
Swimming pools, See Section P116.0						Other Fixtures	
Kitchens for public or employees dining			1 lavatory for the personal use of kitchen employees			One machine or a 3-compartment sink for the effective washing and sanitizing of all cutlery, dishes and glasses before re-use.	
Dwellings—multiple or apartment	1 for each dwelling unit or apartment		1 for each dwelling unit or apartment		1 for each dwelling unit or apartment	Kitchen sink- 1 for each dwelling unit or apartment. Within each dwelling unit, not designed for use by transients, one laundry tray or automatic laundry washing machine; or in a readily accessible location within a general laundry room, 1 two-compartment tray for each 10 dwelling units or 1 automatic laundry washing machine for each 20 dwelling units.	
<p>Notes for Table 16-5:</p> <p>^aThe population used in determining the number of fixtures required shall be based on the number of people to occupy the space but in no case shall the population be less than that determined by allowing 125 sq. ft. of net floor area per person.</p> <p>^bSuch facilities may be in adjacent buildings under the same ownership or control, and shall be accessible during periods when the assembly space is occupied.</p> <p>^cFacilities for employees in a storage building or warehouse may be located in an adjacent building, under the same ownership, where the maximum distance of travel from the working space to the toilet facilities does not exceed 500 ft. horizontally.</p> <p><i>*Local Law 45-1984; Local Law 61-1969</i></p>							

**TABLE 16-6 MINIMUM SIZE OF FIXTURE TRAPS FOR
VARIOUS TYPES OF PLUMBING FIXTURES**

Fixture	Trap Size ^{a,b} (In.)
Bathtub (with or without overhead shower)	1 1/2
Bidets (see section P107.13).....	1 1/2
Combination sink and wash (laundry) tray	2
Dental unit or cuspidor	1 1/2
Drinking fountain	1 1/2
Dishwasher, commercial.....	2
Dishwasher, domestic	1 1/2
Floor drain	3
Funnel drain.....	1 1/2
Kitchen sink, domestic	2
Laboratory, cup sink.....	1 1/2
Laboratory, sink.....	2
Lavatory, common.....	1 1/2
Lavatory, barber shop, beauty parlor or surgeon's.....	1 1/2
Lavatory, multiple type (wash fountain or wash sink).....	1 1/2
Laundry tray (1 or 2 compartments).....	1 1/2
Shower, stall	2
Shower, gang	3
Sink (surgeon's)	1 1/2
Sink (flushing rim type, flush valve supplies)	3
Sink (service type with trap standard)	3
Sink, commercial (pot, scullery, or similar type).....	2
Sterilizers	1 1/2
Urinal (pedestal)	3
Urinal (stall type).....	2
Urinal (wall lip type)	2
Urinal (women's)	3
Water closet (waste outlet)	3

Notes-

^a Size of outlet, the inlet size of trap same as outlet from fixture.

^b Size of three lavatory equivalents-2 in. for more than three.

P105.3 Drainage Pipe Cleanouts.-

(a) Location.-Cleanouts shall be not more than 50 ft. apart in horizontal drainage lines.

(b) Underground drainage.-Cleanouts, when installed on an underground drain, shall be extended vertically and made accessible at the floor, grade, or wall.

(c) Change of direction.-Accessible cleanouts shall be installed at each change of direction greater than 45° on all horizontal pipes of the drainage system.

(d) Base of stacks.-A cleanout shall be provided at, or near, the foot of each vertical inside leader and waste or soil stack.

(e) Direction of flow.-Every cleanout shall be installed so that the cleanout opens in the direction of flow of the drainage line or at right angles thereto.

(f) Size.-Cleanouts shall be of the same nominal size as the pipes for pipes up to 4 in., and not less than 4 in. for larger piping.

(g) Clearances.-

(1) Cleanouts on 3 in. pipes or larger shall be installed

so as to provide clearance of at least 18 in. for the purpose of rodding.

(2) Cleanouts smaller than 3 in. shall be installed so as to provide a 12 in. clearance for rodding.

(h) Kept uncovered.-Cleanout plugs shall not be covered with cement, plaster, or any other permanent finishing material. Where it is necessary to conceal a cleanout plug, a covering plate or access door shall be provided that will permit ready access to the plug.

(i) Equivalent cleanouts.-Fixtures with integral traps, such as water closet and pedestal urinals, or a fixture trap that is readily removable without disturbing concealed roughing work, may be used as a cleanout providing there is no more than one 90 degree bend or sanitary tee on the line to be rodded.

P105.4 Interceptors, Separators, and Neutralizing Pits.-

(a) Interceptors required.-Interceptors or neutralizing facilities of required size and type shall be provided, as

Reference Standard 16

specified herein, for extracting oil, grease, sand, and other substances, harmful or hazardous to the building drainage system, the public sewers, or sewer system as defined in the regulation and the industrial waste permit issued by the department of public works.

(b) Interceptors not required.-A grease interceptor is not required for individual dwelling units or any private living quarters.

(c) Separators required.-At repair garages, gasoline stations with grease racks, grease pits, work racks, and at factories where oily and/or flammable liquid waste are produced, separators of required size and type shall be installed into which all oil-bearing, grease-bearing, and/or flammable wastes shall be discharged before emptying into the building drainage system or other point of disposal. A sand interceptor shall be provided for auto laundries, and no oil separator shall be required.

(d) Grease interceptors.

(1) **COMMERCIAL BUILDING.**-A grease interceptor, meeting the provisions of this reference standard, shall be installed in the waste line leading from pot sinks, scullery sinks, food scrap sinks, floor drains receiving waste or spillage from soup or stock kettles, and the scraper section of commercial dishwashers in all restaurants, kitchens, cafeterias, clubs, or other establishments where grease can be introduced into the drainage system. No rinse water at a temperature of 180° F or higher shall discharge through the interceptor.

(2) **NUMBER OF GREASE INTERCEPTORS.**-One interceptor shall be permitted for all fixtures requiring the interceptor, provided it is individually trapped and vented, and an additional vent is installed at the interceptor, and provided the size of the interceptor is sufficient to accommodate all of the fixtures connected thereto.

(3) **USE AS A TRAP.**-The interceptor may be used in lieu of an individual fixture trap if the developed length from the fixture outlet to the inlet of the interceptor is not more than 48 in.

(4) **CAPACITY.**-Grease interceptors shall have a grease retention capacity, in lbs. equal to at least twice the numerical flow-through rating in gpm (i.e., 2 gpm=4 lbs.). The minimum flow-through rating of grease interceptors shall be equal to the maximum value of all sinks and receptacles that may flow simultaneously through the interceptor divided by the average time for the sinks and receptacles to empty. Interceptors shall remove an average at least of 90 percent of the grease of other extractable matter in the waste water and shall conform with the requirements of the department of public works.

(5) **MATERIAL.**-All prefabricated grease interceptors shall be approved.

(e) Oil and flammable liquids separator.

(1) **SEPARATION OF LIQUIDS.**-A mixture of light and heavy liquids having various specific gravities, such as petroleum hydrocarbons in water, may be treated and then separated in a receptacle complying with the provisions of this reference standard.

(2) **DESIGN OF SEPARATOR.**

a. **Overall requirements.**-Oil separators shall have a depth of at least 2 ft. below the invert of the discharge drain connected thereto. The outlet opening of the separator shall have at least an 18 in. water seal.

b. **Motor vehicle occupancies.**-In automotive service stations, automotive repair shops, and public garages (group I) where not more than four motor vehicles are both serviced and stored, separators shall have a minimum capacity of 6 cu. ft. and 1 cu. ft. capacity shall be added for each vehicle up to ten vehicles. Above ten vehicles, the size of the separator shall be determined by an architect or engineer, subject to the approval of the Commissioner. Where vehicles are serviced only and not stored, separator capacity shall be based on net capacity of 1 cu. ft. for each 100 sq. ft. of surface to be drained into the separator, with a minimum of 6 cu. ft.

c. **Other occupancies.**-In other buildings where oil or other flammable liquids are stored or used, no physical connection or internal arrangement that could permit the accidental or deliberate introduction of such materials directly or indirectly into the sewer system will be permitted. Where such substances might overflow by spillage or other circumstance not attributable to a direct connection of the plumbing system, every precaution shall be taken through the presence of protective dikes and similar devices to prevent such substances from reaching the public sewers.

(3) **VENTING.**-Oil separators shall be vented in accordance with Section P105.6.

(4) **CONNECTION TO SEWER.**-The discharge of an oil separator shall be independently connected to the street sewer or to the sewer side of the house trap. Where the oil separator is located below the street sewer, the sump receiving the effluent from the separator shall be gastight and vented in the same manner as the separator.

(5) **OIL STORAGE TANK.**-Each separator shall have an oil storage tank available for storing the residue from the separator. Tanks shall be installed in accordance with Article 14.

P105.5 Interceptors, Separators, and Neutralizing Pits for Specific Services.

(a) Sand interceptors.-commercial establishments.-Sand and similar interceptors for heavy solids shall be so designed and located as to be readily accessible for cleaning, and shall have a water seal of at least 6 in.

(b) Laundries.-Commercial laundries shall be equipped with an interceptor having a wire basket or similar device that is removable for cleaning, and that will prevent passage into the drainage system of any solids 1/2 in. or larger in size, or strings, rags, buttons, or other materials detrimental to the public sewerage system. Interception within a trough will be permitted.

(c) Bottling establishments.-Bottling plants shall discharge their process wastes into an interceptor that will intercept broken glass and other solids before discharging liquid wastes into the drainage system.

Reference Standard 16

(d) Slaughter houses.-Slaughtering room and dressing room drains shall be equipped with separators or interceptors that shall prevent the discharge into the drainage system of feathers, entrails, and other materials likely to close the drainage system.

(e) Laboratories, dyeworks, and chemical plants.-In establishments discharging sewage, industrial wastes, or other wastes that will reduce the pH value of the waste water discharged to the public sewer system below 4.5 or raise it to above 11.5 at the point or points of such discharge, provisions shall be made for neutralizing such waste water to conform with the regulations of the department of public works. Where applicable, a suitable neutralizing pit shall be installed that is of sufficient capacity to hold an adequate quantity of marble chips or similar neutralization substance to satisfactorily bring the pH value of the waste water to acceptable values. Baffles and other flow guiding devices may be introduced to insure that the acid or alkaline wastes are thoroughly contacted by the neutralizing substance. The venting arrangement for this pit shall be in conformance with the applicable provisions of this code.

P105.6 Venting of Interceptors, Separators, and Neutralizing Pits.-

(a) Oil interceptors and separators.-

(1) Interceptors and separators shall be so designed that they will not become air bound if closed covers are used. Each interceptor or separator shall have an individual 3 in. vent extending from the top of the separator to the outside air at a point at least 12 ft. above street level.

(2) A fresh air inlet shall be provided from the drain line at the inlet side of the separator to the outside air at a point at least 6 in. above grade.

(3) A separator shall be accepted in lieu of a house trap.

(4) The horizontal drain line and at least one stack shall be at least 3 in. in diameter. Stack shall be carried full size through the roof.

(b) Neutralizing pits and interceptors (other than oil).-Interceptors, separators, and neutralizing pits shall be so designed that they will not become air bound if closed covers are used. Each interceptor that is provided with a cover shall be vented, and the vent may connect into the sanitary vent system.

P105.7 Accessibility of Interceptors, Separators and Neutralizing Pits.-Each interceptor, separator, and neutralizing pit shall be so installed that it is readily accessible for removing the cover, for servicing, and for maintenance.

P105.8 Maintenance of Interceptors, Separators, and Neutralizing Pits.-Interceptors, separators, and neutralizing pits shall be maintained in efficient operating condition by periodic removal of accumulated grease, scum, oil, or other floating substances, and solids deposited in the interceptor, separator, or neutralizing pit. Improper maintenance of interceptor, separator, or neutralizing pit

may constitute sufficient cause for revocation of the industrial waste permit for the premises issued by the department of public works or may constitute a violation of the fire prevention code.

P105.9 Backwater Valves.-

(a) Fixtures and area drains subject to backflow.-Where fixtures, floor drains, or area drains are subject to overflow as the result of backwater from the public sewer system, accessible backwater valves shall be installed in the fixture drain pipe from such fixture, in the branch drain to such area drain or group of fixtures, or in the building drain at its point of exit from the building and downstream from the building trap. Masonry access manholes shall be provided when the centerline of any drain line is 18 in. or more below a slab on grade.

(b) Design.-Backwater valves shall provide a positive mechanical seal against backwater, and when fully opened shall have the same discharge flow capacity as the pipe in which it is installed. All bearing parts shall be made of corrosion resistant metal or other equivalent material. The flap shall be so designed as to hang partially open when not subject to backwater pressure.

P105.10 Industrial Wastes Sampling Manholes.-

All premises intended for the discharge of sewage, industrial wastes, or other wastes with characteristics that do not conform to those prescribed for normal sewage as defined in regulations promulgated by the department of public works, shall contain a suitable common control manhole into which all flow of sewage, industrial wastes, or other wastes are combined. When the installation of such a common manhole is impossible, impractical, or will interfere with treatment facilities required for the issuance of an industrial waste permit by the department of public works, the owner of such premises shall construct, in lieu of the common manhole, two or more manholes as required by the department of public works, for accurate measurement of all flows of sewage, industrial wastes, or other wastes before discharging from such premises into the sewer system.

Section P106.0 Hangers and Supports

P106.1 Material.-Hangers, anchors, and supports shall be of metal or equivalent material of sufficient strength to support the piping and its contents. Piers may be of concrete, brick, or equivalent material.

P106.2 Attachment to Building.-Hangers and anchors shall be securely attached to the building construction at sufficiently close intervals to uniformly support the piping and its contents.

P106.3 Intervals of Supports.-

(a) Vertical piping.-Vertical piping of the following materials shall be supported, using either guide or friction hangers or a combination of both, at the following intervals:

Reference Standard 16

- (1) Cast iron soil pipe at base and at each story height, but in no case at intervals greater than 20 ft.
- (2) Threaded pipe (SPS).-At every other story height, but in no case at intervals greater than 25 ft.
- (3) Copper tubing (hard temper).-At each story height.
- (4) Other materials.-As required for structural stability and service.

(b) Horizontal piping.-Horizontal piping of the following materials shall be supported at intervals no greater than the following:

- (1) Cast iron soil pipe.-At 5 ft. intervals and behind every hub.
- (2) Threaded pipe (1 in. or less).-At 8 ft. intervals.
- (3) Threaded pipe (1 1/4 in. or over).-At 12 ft. intervals.
- (4) Copper tubing (1 1/4 in. or less).-At 6 ft. intervals.
- (5) Copper tubing (1 1/2 in. or over).-At 10 ft. intervals.
- (6) Other materials.-As required for structural stability and service.

(c) Base of stacks.-Bases of cast iron stacks shall be supported on concrete, on brick laid in cement mortar, by metal brackets attached to the building construction, or by equivalent methods. Stacks of other material shall be anchored so as to relieve the load from the base of the stack.

***P106.4 Installation of no-hub type cast iron soil pipe, fittings, and couplings.-**

All installations of no-hub type cast iron soil pipe, fittings and couplings shall comply with the following: CISPI Designation 310-1985 Specification for Cast Iron Soil Pipe Institute's Approved Coupling for Use in Connection with Hubless Cast Iron Soil Pipe and Fittings for Sanitary and Storm Drain, Waste, and Vent Piping Applications.

**Local Law 100-1989*

Section P107.0 Water Supply and Distribution

P107.1 Permits.-

- (a) Permits for all water supplies for all buildings or for demolitions shall be obtained from the department of water supply, gas, and electricity. The installation of the water service system from the street main up to and including the meter setting when meters are required, or up to the house control valve when no meters are required, shall be subject to inspection and approval by the department of water supply, gas and electricity.
- (b) Permits for sidewalk and street openings shall be obtained from the department of highways.

P107.2 Water Service.-

(a) Taps to city water mains.-

- (1) SEPARATE SUPPLY.-A separate tap and service shall be installed for each building fronting on a street in which there is a city (street) water main, and no consumer will be allowed to supply water to other persons or premises, except in a project where more than one building under a single ownership is supplied from a common house tank or booster system located in or on one of the buildings.

(2) CONNECTIONS TO CITY (STREET) MAINS.- Corporation stops, wet connections, or other connections to a street main shall be made only by the department of water supply, gas and electricity employees. The cost of the installation shall be borne by the owner of the property for which the connection is made.

(3) DESTRUCTION OF ABANDONED CORPORATIONS STOPS AND WET CONNECTIONS.- All driven corporation stops, when abandoned, shall be removed and replaced by plugs. All wet connections or screw corporation stops, when abandoned, shall be destroyed in place, and all exposed portions of the service pipe shall be cut and removed. Where a corporation stop or wet connection is destroyed and the connecting service pipe is one that is equipped with a curb valve and box, the curb box shall be removed. The expense in connection with the abandonment or destruction of a corporation stop or wet connection shall be chargeable to the owner of the property into which the service pipe entered.

(b) Service.-

(1) SERVICE PIPES, DEFINITION.-See Section P100.0.

(2) SIZE OF TAPS AND WATER SERVICE.-The size of service pipe to supply a premise shall be based upon the water demand load of the premises as determined by "fixture units". "Fixture units" shall conform to the requirements of the department of water supply, gas, and electricity. In premises used for commercial and industrial purposes where it is not feasible to determine the size of the service pipe on the basis of "fixture units," the size of the service pipe shall be based upon the water demand load of the premises. The minimum size service shall be 1 in. in diameter, and the gooseneck shall be the same size as the service pipe.

(3) SIZE OF FIRE LINE SERVICE.-Sizes of connections for fire service shall be subject to the requirements of the department of water supply, gas, and electricity.

(4) SEPARATION OF WATER SERVICE AND BUILDING SEWER.-Except as permitted below, the underground water service and the building sewer shall be at least 10 ft. apart horizontally, and shall be separated by compacted earth. The water service may be placed in the same trench with the building sewer and building drain under the following conditions:

- a. The sewer is of cast iron with leaded or mechanical joints.
- b. The bottom of the water service, at any point, shall be at least 12 in. above the top of the sanitary or combined sewer line.
- c. The water service shall be placed on a continuous shelf of compacted earth, excavated at one side of the common trench.
- d. The water service pipe shall have a minimum number of joints.

(5) WATER SERVICE NEAR SOURCES OF POLLUTION.- Potable water service pipes shall not be located in, under, or above any cesspools, septic tanks, septic tank drainage fields, or seepage pits. A separation of 10 ft. horizontally shall be maintained.

(6) PROTECTIVE COVER FOR SERVICE PIPE.-All

Reference Standard 16

water services shall be installed and maintained at a depth of at least 4 ft. below the finished outside ground surface. Where a service pipe has less than 4 ft. of cover due to subsurface conditions, it shall be insulated and protected as required by the department of water supply, gas, and electricity.

(7) **INSTALLATION OF SERVICE PIPE.**-Each new service pipe shall be laid in a straight line at right angles to the street main and extending from the tap to the main house-control valve. Where the surface or subsurface conditions make it impracticable to install a service pipe in accordance with the above conditions, it may be laid differently provided a sketch or plan showing the proposed alternate location of the service pipe is submitted to and approved by the department of water supply, gas and electricity. The driving of a service pipe through the ground is prohibited.

**** (8) GOOSENECKS ON SERVICE PIPE.**-

Connections to the city main by cast iron or ductile iron pipe may be made directly; no offset swing joint will be required. Each copper tubing service pipe shall have an excess of at least 3 ft. of pipe formed in a gooseneck at the connection to the tap and laid to the right side, facing the tap. Each brass or copper service pipe shall have, at the tap or wet connection, a copper tubing gooseneck of at least 3 ft. of pipe, or an offset swing joint consisting of four elbows and three pieces of pipe each at least 2 ft. in length, laid to the right side, facing the connection.

Where buildings are constructed on pile foundations or other unyielding supports, the service pipes of material other than cast iron or ductile iron shall have two goosenecks, one at the tap and one immediately outside the building. A sleeve shall be installed to carry the service through the foundation wall.

****Local Law 29-1987**

(9) **CURB VALVES.**-Curb valves shall be installed on all fire service pipes. They shall be installed on all domestic service pipes over 2 in. in diameter and at the option of the owner, on service pipes 2 in. or less in diameter. The curb valves and boxes shall be set in the service pipe in the sidewalk area at the curb or within 2 ft. of the curb. Curb valves shall be of the gate type nonrising stem valve, designed for a minimum of 150 psi wwp.

Access to all curb valves installed shall be provided by a tar coated iron extension box with cover, and the cover shall be flush with the sidewalk level. Curb valves 2 in. and less in diameter may be equipped with a wheel for operation, provided a permanent 1/2 in. diameter iron rod is attached thereto and extended to the top of the curb box. No curb valve shall be installed in a driveway. Curb valves larger than 2 in. in diameter shall be equipped with an operating nut at least 1 1/4 in. square and no extension rod need be attached thereto. Such operating nut may be installed on curb valves 2 in. and less in diameter at the option of the owner.

In sprinkler and fire line installations, the location of

the sidewalk control valve shall be governed by the provisions of the building code.

(10) **CLEARANCE.**-Clearance shall be provided around a water service pipe passing through a wall to protect it against the following:

- a. Chemical action from direct contact with concrete.
- b. Distortion or rupture of water service pipe from shearing action due to settlement.
- c. Distortion or rupture of the water service pipe caused by expansion or contraction.

Clearance shall not be less than 1/2 in. between the outside of the pipe and the wall. Sleeves or arches may be used to provide the wall opening. The space between the pipe and the wall structure or the sleeve shall be carefully packed or caulked with lead or waterproof material resistant to vermin and rodents.

(11) **TEST OF SERVICE OF SERVICE PIPE.**-In the presence of the tapper or inspector of the department of water supply, gas, and electricity, each new service pipe or repaired service pipe shall be subjected to a water test made under the street main pressure. All pipes and appurtenances shall remain uncovered for the duration of the test and shall show no sign of leakage. When any question arises as to the installation conforming with these regulations, an internal hydrostatic test as specified for materials may be applied, subject to the approval of the department of water supply, gas, and electricity.

***** (12) HOUSE CONTROL VALVES.**-The house control valve shall be of the gate or full port ball type, and shall be placed in the service pipe inside the building within 2 ft. of the building foundation wall and located so as to be accessible at all times. All valves shall be designed for a minimum of 150 psi and gate valves may be of the outside screw and yoke type.

*****Local Law 10-1999.**

P107.3 Meters.-

(a) Where required.-

(1) **BUILDINGS UNDER CONSTRUCTION.**-All water used in the construction of buildings 75 ft. or six stories or more in height shall be metered. Prior to the commencement of actual building construction, a meter of proper size shall be installed on each tap or service supplying the premises. It shall be placed in an accessible location close to the point of entry of the service pipe, as designed by the department of water supply, gas and electricity. Each meter shall be enclosed in a vault or box capable of providing adequate protection against damage or injury from frost or any other cause. Each meter shall remain in service throughout the entire period of building construction, and thereafter until such time as the annual water charges for the structure becomes effective or the permanent meter has been installed. No permit will be issued for the installation of a meter to register the supply of water used for the construction of a building six stories in height or less. Such water will be charged for as required by the department of water supply, gas, and electricity.

*** (2) FIRE LINES.** Combined fire/domestic service for

Reference Standard 16

new sprinkler systems in residential buildings up to six stories or seventy-five feet in height may use one fire-rated compound meter on the combined service or a standard displacement meter on the domestic branch and a detector check valve assembly on the fire branch. If a fire-rated compound meter is used, it shall be certified or listed by the Underwriters Laboratories or The Factory Mutual System or an equivalent national listing organization.

**Reference to Local Law 5-1973 removed by Local Law 10-1999.*

(3) **REFRIGERATION AND AIR CONDITIONING.**-Where the rate of water required for operation of refrigeration and air conditioning apparatus exceeds 1/2 gpm, the building supply shall be metered, as required by the department of water supply, gas, and electricity.

(4) **MISCELLANEOUS FIXTURES.**-The following fixtures or devices shall not be installed or used except where the supply of water to the fixture or devices is metered or connected to a metered distribution system: display fountains containing over 1,000 gal. of water; aquariums containing over 300 gal. of water; irrigation systems; swimming tanks, wading pools, or plunge baths containing more than 5,000 gal. of recirculated water; or hydrotherapy devices requiring the use of city water for their operation.

(b) **Location of meters.**-In all premises where the supply of water is to be fully metered, the meter shall be set within 3 ft. of the building foundation or vault wall at the point of entry service pipe. The service pipe between the house control valve and the meter shall be kept exposed. When a building is situated in back of the street line or when conditions exist in a building that prevent the setting of the meter at a point of entry, the meter may be set outside of the building within the property line, provided the meter is installed in an accessible, watertight, and frost-proof pit or meter box. All meter locations shall be subject to approval by the department of water supply, gas, and electricity.

(c) **Setting of meters.**-In setting or resetting a meter, the requirements are as follows:

(1) The meter shall be set so that the dial faces upward and is horizontal. The dial shall not be more than 3 ft. above the floor.

(2) Connections shall be made by a coupling, union, or flange union on both the inlet and outlet end of the meter and bored for sealing with holes at least 3/32 in. in diameter. Union or couplings that would permit removing the meter setting without breaking the seal wiring are prohibited.

(3) A house valve shall be installed in the service pipe on the inlet side of the meter within 1 ft. of meter except that when a current meter is set, a straight section of pipe with a length of eight times of diameter of the meter inlet size, shall be installed immediately before the inlet between the control valve and the meter with no fittings of any kind installed in the straight section of pipe.

(4) A valve shall be installed on the outlet of all meters of 1 in. size or larger.

(5) A full sized test tee shall be placed on all 1 1/4 in., 1 1/2 in., and 2 in. meters, on the outlet between the meter and the outlet valve, with a short, capped nipple in the tee.

(6) A test tee with a 2 in. opening shall be placed on all meters 3 in. and larger on the outlet between the meter and outlet valve with a short nipple in the tee, and a 2 in. valve shall be placed on the nipple.

(7) All meters not equipped with a test tee and outlet valve shall have a tee with a faucet in it inserted in the line on the outlet side within 2 ft. of the meter, except that this requirement may be waived where other readily accessible means are provided for testing the meter to determine whether the meter is registering correctly.

(8) No connection shall be made to a test tee.

(9) Before setting meters 3 in. and larger, a plan or sketch showing the proposed installation, and indicating the location of service control valve inside of the building, the distance of the meter from the point of entry of service, the height from floor, the size and the type of meter, and the approximate date of setting shall be filed in duplicate with the department of water supply, gas and electricity for approval.

(d) **Size and type of meter.**-

(1) **APPROVED METERS.**-Meters shall conform to standards approved by the department of water supply, gas, and electricity.

(2) **SIZE.**-A meter shall be restricted to a size that will give accurate registration on the basis of consumption and occupancy of the premises or portion of the premises metered. The meter in no case may be more than one standard size larger than the tap or connection to the city main. The piping of the meter setting from the inlet valve to the outlet valve shall be of the same size as the meter. Where inaccuracy of registration is found to be due to the improper size of the meter, such meter shall be replaced with another meter of a size designated by the department of water supply, gas, and electricity.

P107.4 Check Valves.-

(a) A check valve shall be placed in all services where one of the following conditions exist:

(1) Where a building is supplied by services connected to different mains.

(2) Where there is any possibility of backflow from tanks, siamese connections, or other apparatus or fixtures within the building.

(b) Such check valves shall be placed within 2 ft. of the outlet side of the main house-control valve or on the metered connections between the meter test tee and the outlet valve.

P107.5 Water Supply Distribution System.-

(a) **Design, adjustment, and maintenance.**-The water supply distribution system shall be designed and adjusted to supply fixtures and equipment with the amount of potable water required for proper use, cleansing and

Reference Standard 16

performance. Pipe sizing shall be predicated on hydraulic design by an architect or engineer, subject to the approval of the Commissioner.

(b) Minimum pressure.-

(1) The minimum pressure available near the faucet or water outlet with the water outlet wide open shall be 8 psi.

(2) At all other equipment and flush valves requiring more than 8 psi, the minimum flow pressure shall be the pressure required for satisfactory performance.

(3) Where street main pressure fluctuates, the building water distribution system shall be designed for the minimum pressure available.

(c) Inadequate water pressure in street mains.-

Whenever water pressure from the street main or other source of supply is insufficient to provide pressures at fixture outlets, an auxiliary supply shall be provided in

accordance with Section P107.7.

(d) Maximum pressures.-Where the static or street main pressure exceeds 85 psi on fixtures, a pressure reducing valve shall be installed to reduce the pressure to 85 psi or less at the fixture with no flow and the fixture closed. Sillcocks and outside hydrants may be left at full pressure.

(e) Minimum size of water supply branches and risers.-

(1) The minimum size of an individual branch supply to a fixture shall be predicated on supplying the flow of water listed in Table RS 16-7 at velocities not in excess of 8 fps.

(2) The branches, risers, and headers shall be sized to produce velocities not in excess of 8 fps for the flow predicated on the probable demand of flow in the branch, riser, or header pipe.

TABLE RS 16-7 MINIMUM RATE OF FLOW AND MINIMUM REQUIRED PRESSURE DURING FLOW FOR SIZING INDIVIDUAL BRANCH SUPPLIES FOR PLUMBING FIXTURES

Location	Flow Pressure ^a (psi)	Flow Rate ^b (gpm)
Ordinary basin faucet	8	2.0
Self-closing basin faucet.....	8	2.5
Sink faucet, 3/8 in.	8	4.5
Sink faucet, 1/2 in.	8	4.5
Bathtub	8	5.0
Laundry tub cock, 1/2 in.	8	5.0
Shower	8	5.0
Ball-cock for closet	8	3.0
Flushometer valve for closet	10-20	15-40 ^c
Flushometer valve for urinal	10	15.0
Drinking fountains	—	0.75

Notes-

^a The flow pressure is the pressure in the supply pipe, near the faucet or water outlet while the faucet or water outlet is wide open and flowing.

^b At fixtures supplied with both hot and cold water, the flow rate indicated is for each of the two connections.

^c The wide range is due to the variation in designs and types of water closet flush valves and water closets.

(f) Water hammer.-All building water supply systems shall be provided with devices to absorb shocks resulting from high pressure caused by the quick closing of valves. These pressure absorbing devices shall be either air chambers or mechanical devices. Water pressure shock absorbers may be installed at the end of long pipe runs or near batteries of fixtures.

(1) Air chambers installed on the main service shall be in an accessible place, and each air chamber shall be provided with a means for restoring the air should the chamber become waterlogged.

(2) Air chambers installed at individual fixtures need not be accessible. Air chambers for fixtures shall be at least 12 in. long and of the same diameter as the branch pipe connection; for quick closing valves the chamber shall be at least 18 in. long. One air chamber may service a battery of fixtures provided the single air chamber is at least 24 in. long and is at least the size of the supply branch.

(3) Mechanical devices shall be used in accordance with the manufacturers' specifications as to location and method of installation.

P107.6 Water Supply Control Valves.-

(a) Stop-and-waste valves prohibited.-Combination stop-and-waste valves or cocks shall not be installed in underground or buried water supply piping.

(b) Riser valves.-Except in a one-family dwelling, a valve shall be installed at the foot of each water supply riser. In multistory buildings, a valve shall be installed at the top of each water supply down-feed pipe.

(c) Valves in dwelling units.-In two-family dwellings and in dwelling units of buildings classified in occupancy group J-2, control valves on the supply branch or stop valves on each individual fixture shall be provided so that the water to any dwelling unit may be shut off without stopping the flow of water to other units.

(d) Individual fixture valves.-In buildings of occupancy other than those in (c) above, the supply branch to the group of fixtures or the supply branch to each fixture or piece of equipment shall be provided with a valve or a fixture stop valve to shut off the water to the fixture or to the room in which it is located.

(e) Tank controls.-Supply lines to and from pressure

Reference Standard 16

or gravity tanks shall be supplied with valves at the tanks within the tank room.

(f) Water heating equipment valve.-The cold water branch to each hot water storage tank or water heater shall be provided with a valve located near the equipment. Each tank or heater shall be equipped with an approved automatic relief valve as prescribed in Section P107.26.

(g) Accessibility.-All water supply control valves shall be placed so as to be readily accessible for service and maintenance.

(h) Control valve design.-Except the valves serving single fixtures, control valves on all water lines shall, when fully opened, have a cross-sectional area of at least 85 percent of the cross-sectional area of the line in which they are installed.

(i) Bath and shower valves.-Valves for individual showers or bathtubs, or multiple gang showers shall be balanced pressure-mixing valves, or thermostatic mixing valves, or combination pressure balancing/thermostatic valves, conforming to the requirements of ASSE 1016 (December 1988). Water temperature control valves shall be equipped with high-limit stops adjusted to a maximum hot water setting of 120 degrees Fahrenheit (49 degrees Celsius).

**Local Law 86-1996*

(a) When required.-When the pressure in the street water main or individual water supply system is insufficient to supply the probable peak demand flow to all plumbing fixtures and other water needs freely and continuously, and with the minimum pressures and quantities as prescribed in Section P107.5, or elsewhere herein, the rate of supply shall be supplemented by one of the following:

- (1) An elevated gravity water supply tank.
- (2) A hydropneumatic pressure booster system.
- (3) A water pressure booster pump system.
- (4) A combination of these systems.
- (5) Other systems designed by an architect or engineer, subject to the approval of the commissioner.

P107.8 Water Supply Tanks.-

(a) Overflows.-Each gravity or suction water supply tank shall be provided with an overflow not smaller than shown in Table RS 16-8 and/or RS 16-9. The gallons per minute listed in the tables shall be the total automatic pump capacity connected to the tank, or the calculated carrying capacity of the fill pipe. The overflow outlet shall discharge within 6 in. of a roof or roof drain, or over an open water supplied fixture. The overflow discharge shall be provided with durable screening with openings of not more than 1/8 in.

P107.7 Auxiliary Water Systems.-

**TABLE RS 16-8 SIZE OF OVERFLOWS FOR GRAVITY AND SUCTION TANKS
(See Figures RS 16-1 A and B)**

Overflow Pipe Size (in.)	Maximum Allowable gpm for each Orifice Opening into Tank	Maximum Allowable gpm for Vertical Overflow (Piping Connecting Orifices)
2	19	25
3	43	75
4	90	163
5	159	296
6	257	472
8	505	1,020
10	890	1,870
12	1,400	2,967

**TABLE RS 16-9 SIZE OF WEIRS FOR GRAVITY AND SUCTION TANKS
(See Figure RS 16-1C)**

Slotted Weir Opening into Tank between Overflow Chamber and Water Compartment ^a	Maximum gpm Allowable for Weir
3 in. x 24 in.	381
3 1/2 in. x 24 in.	475
4 1/2 in. x 24 in.	685
4 1/2 in. x 36 in.	1,037
6 in. x 36 in.	1,569
6 in. x 48 in.	2,100

Note-

^a Bottom of the overflow chamber must be at least 6 in. below weir.

Bottom outlet shall be provided in the chamber of sizes based on capacities as indicated in table RS 16-8.

Reference Standard 16

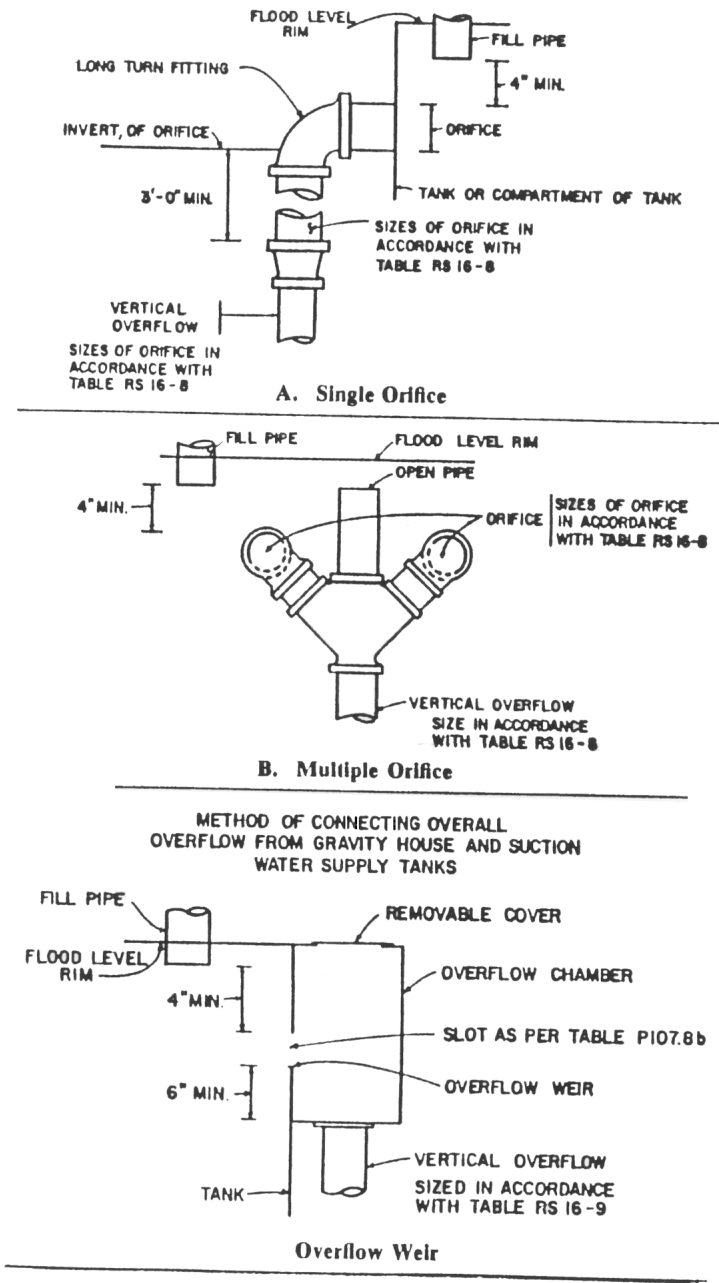

Figure RS 16-1

(b) Water piping control and location.-Water inlets to gravity house tanks shall be controlled by a ball cock or other automatic supply valve or emergency electrical cut-off so installed as to prevent the overflow of the tank in the event that the pumps filling the tanks do not shut off at the predetermined level or the street pressure rises to a point where it can fill the tank. The water inlet to a suction tank shall be controlled by a ball cock or other automatic supply valve. The inlet shall be terminated so as to provide an accepted air gap but in no case shall it be less than 4 in. above the top of the overflow. The outlet from a gravity tank to the distribution system shall be equipped with a strainer located at least 2 in.

above the tank bottom to prevent solids from entering the piping system. All down-feed supplies from a tank cross-connected in any manner with distribution supply piping in a building supplied by direct street or pump pressure, shall be equipped with a check valve on the main cold water down supply to prevent backflow of water into the roof tank.

(c) Drain pipes for emptying tanks.-Each tank or tank compartment shall be provided, at its lowest point, with a valved pipe to permit emptying the tank. The drain pipe shall discharge as required for the overflow pipe, and shall be at least 4 in. in diameter.

(d) Prohibited location.-Potable water gravity tanks or manholes of potable water pressure tanks shall not be located directly under any soil or waste piping.

(e) Design.-The gravity house supply tank shall be built of wood, steel, or equivalent materials. Subject to the approval of the Commissioner, additional linings may be installed in the tank, provided the lining material does not have a toxic or otherwise objectionable effect on the potable water. Steel tanks shall be painted both inside and outside. If a tank with a dividing partition is installed, the total capacity of the combined compartments shall be considered as the capacity of a single tank for the purpose of determining storage capacities of the tank.

(f) Hydropneumatic pressure booster tanks.-Pressure tanks shall be cylindrical and shall be built in accordance with the ASME Boiler Code, 1967, Section VIII. The tank shall be galvanized or painted both inside and outside unless it is constructed of a nonferrous material. The tank shall be provided with a pressure relief valve. Also, it shall be provided with a vacuum relief if the tank is located and installed so that it can be drained by a fixture located below the tank. The air supplied to the tank shall be filtered and taken from an area that does not impart any toxicity to potable water stored in the tank.

(g) Cleaning or painting.-

(1) No water tank of any kind that is part of a building water supply system used for potable purposes shall be cleaned with any material or painted on the inside with any material that will have a toxic or otherwise objectionable effect on the potability of the water supply when the tank is put into service. No lead paint shall be used. The water supply connections to and from a tank shall be disconnected or plugged while the tank is being cleaned or painted to prevent any foreign fluid or substance from entering the distribution piping. Where the air in a tank may be insufficient to sustain human life, or may contain an injurious gas, adequate measures shall be taken for the protection of the workmen.

(2) After the tank has been cleaned or painted, it shall be disinfected according to the following procedure before it is put back in service:

- a. The underside of the top, the bottom, and the walls shall be washed with a hypochlorite solution containing 100 or more parts per million of available chlorine.
- b. The tank shall be filled with water to which hypochlorite solution is added during the filling in sufficient quantity

Reference Standard 16

so that the treated water in the tank will contain at least 10 parts per million of available chlorine.

c. The chlorinated water shall be allowed to remain in the tank for two hours.

d. Finally, the tank shall be drained completely before refilling.

(3) House and suction tanks shall be drained and cleaned at least once a year.

(h) Supports.-All water supply tanks shall be supported in accordance with the requirements for structural work of the building code.

(i) Covers.-All water supply tanks shall be covered to keep out dirt, vermin, and unauthorized persons.

P107.9 House and Booster Pumps.-

(a) Directly off street main.-Power pumps may draw their water supply directly from the street main if the total connected automatic pump capacity is not more than 400 gpm. If the total connected automatic capacity exceeds 400 gpm, the pumps may be connected directly to the street main only if permitted by the department of water supply, gas, and electricity.

(b) Suction tank.-

(1) When the pumps cannot be connected directly to the water service main a suction (surge) tank shall be installed. Suction tanks shall be constructed in accordance with the requirements of Section P107.8.

(2) No suction tank will be required for a fire pump except where the size of the fire service is equal to or greater than the size of the street main.

(c) Suction tank size.-Suction tanks when required, shall have a capacity not less than prescribed in Table RS 16-10.

TABLE RS 16-10 SUCTION TANK SIZES

Total Connected Pump Capacity (gpm)	Tank Capacity (gal.)
400-500	(7,500)
501 and over	(10,000)

(d) Fill line to tank.-A fill connection to a suction tank shall be provided with a flow control that will limit the water make-up rate to the suction tank under the pressure conditions and at the maximum quantities permitted by the department of water supply, gas, and electricity.

(e) Low pressure cut-off required on booster pumps.-When a pump is directly connected to the street main, a low pressure cut-off shall be installed on the house side of each building control valve and on the street side of each meter assembly to prevent the pressure from dropping more than 7 psi below the normal static pressure at the point of entry of the water service, or as required by the department of water supply, gas, and electricity.

(f) Check valves required.-Each pump discharge shall be provided with a check valve and gate valve.

P107.10 Protection of Potable Supply.-

(a) General.-A potable water supply system shall be

designed, installed, and maintained in such manner as to prevent contamination from non-potable liquids, solids, or gases from being introduced into the potable water supply through cross-connections or any other piping connections to the system.

(b) Identification of potable and non-potable water.-In all buildings having dual water distribution systems, one potable water and the other non-potable water, each system shall be identified either by color marking or metal tags.

(c) Color marking.-When color marking is used, potable water lines shall be painted green and non-potable water lines shall be painted yellow. This requirement may be met by painting 3 in. wide bands, green or yellow, at intervals of not more than 25 ft. and at points where piping passes through walls, floors, or roofs, in which case the bands shall be applied to the piping on both sides of the walls and both above and below the floor or roof. Points of outlets for nonpotable water shall be marked with a tag or color code.

(d) Metal tags.-When tags are used, potable water lines shall be identified by 3 in. diameter metal tags bearing the legend "SAFE WATER" in letters at least 1/2 in. high. Non-potable water lines shall be identified by firmly attached metal tags having the shape of a 4 in. equilateral triangle bearing the legend "WATER UNSAFE" in letters at least 1/2 in. high. As in the use of color bands, tags shall be attached to pipes at intervals of not more than 25 ft. and at both sides at points where pipes pass through walls, and both above and below points where pipes pass through floors or roofs.

P107.11 Toxic Materials and Substances.-No materials or substances that could produce either toxic conditions or add taste or odor to a potable water system shall be introduced into or used in such systems.

P107.12 Used Piping.-Piping that has been used for any purpose other than conveying water shall not be used for conveying potable water.

***P107.13 Prohibited Connections To Fixtures And Equipment.**-The following equipment shall receive water supply only through air gaps and direct water connections to the potable water supply system shall be prohibited unless a reduced pressure principle back pressure backflow preventer is installed between the water supply and the equipment.

- (1) Bidets with submerged water connection that cannot drain out after shut off.
- (2) Aspirators, injectors, ejectors or water siphons and similar apparatus.
- (3) Mortuary, dissection, operating and embalming tables or similar equipment.
- (4) Sterilizers.
- (5) Flushing rim floor drains.

**Local Law 69-1977*

P107.14 Connections to Mechanical Equipment and Systems.-Potable water connections to boiler feed water systems and heating or cooling systems shall be

Reference Standard 16

made through a fixed air gap. Where the equipment or system is fed through an injector the potable water shall be supplied through a fixed air gap to the suction tank of a booster pump.

P107.15 Refrigeration Unit Condensers and Cooling Jackets.-Where potable water is provided for a refrigerator condenser or cooling jacket the connection must be entirely outside of the piping or tank containing the toxic refrigerant shall be used. The inlet connection shall be provided with check valve and, if the refrigeration units contain more than 20 lbs. of refrigerant, with an approved pressure relief valve set to relieve at 5 psi above the maximum water pressure at the point of installation, adjacent to and at the outlet side of the check valve.

P107.16 Air Conditioning and Refrigeration.-

- (1) Each direct water connection to a refrigeration or air conditioning unit using city water for cooling purposes shall be equipped with a check valve located not more than 2 ft. from the unit.
- (2) Where the refrigeration or air conditioning system in a building is in excess of 1/3 ton, the city water supply to such building shall be metered.
- (3) Where the refrigeration or air conditioning unit using city water is 1/3 ton or less, and the unit is located in a metered premise, the unit shall be connected to the metered supply.
- (4) All systems of refrigeration in excess of 6 tons and/or air conditioning in excess of 3 tons shall be equipped with a water conserving device. Ice cubers and ice flakers shall be exempted from this requirement. The tonnage shall be the combined or total tonnages for all water cooled refrigeration systems for air conditioning or any other purpose installed in any one building.
- (5) In buildings where the tonnage is less than the tonnage specified in (4) above, an approved automatic regulating device shall be installed at each refrigeration unit.
- (6) Where city water is supplied to a water conserving device, other than a combination air and water cooled condenser, the piping supplying such water shall discharge at least 2 in. above the overflow rim of the pan.
- (7) The waste water from all systems having direct connection to the city water supply shall be discharged (outlet of the discharge piping) shall be located at least 1 in. above the overflow rim of said receptacle.
- (8) "Automatic water regulating valve or device" shall mean a self-regulating valve or other device that shall limit the use of city water to 1.5 gpm or less per ton of refrigeration or air conditioning.
- (9) "Water conserving device" shall mean an evaporative condenser, water cooling tower, spray pond, economizer, or similar apparatus that shall not consume city water for make-up purpose in excess of 2 percent of the amount that would normally be used without such device. In addition, 3 percent of the amount of water that would normally be used without such device shall be allowed for purpose of bleeding and wash down.

P107.17 Used Water Return Prohibited.-

Water used for cooling of equipment or other processes shall not be returned to the potable water system. Such water shall be discharged into the drainage system through an air break to a receptacle or fixture.

***P107.18 Protection Against Backflow and Back-Siphonage.**-Unless otherwise provided in this code, protection of the potable water system against backflow and back-siphonage shall be by providing, installing, and maintaining at each outlet one of the following:

- (1) Air Gap: In accordance with ANSI A112.1.2-1942 (R1973).
 - (2) Vacuum Breaker: In accordance with ANSI A112.1.1-1971 (ASSE No. 1001-1970).
 - (3) Reduced Pressure Principle Back Pressure Backflow Preventer: In accordance with ASSE No. 1013-1974.
 - (4) Double Check Valve-Type Back Pressure Backflow Preventer: In accordance with ASSE No. 1015-1972.
 - (5) Backflow Preventer With Intermediate Atmospheric Vent: In accordance with ASSE No. 1012-1972.
- Vacuum breaking and backflow preventing devices shall be accessibly located, preferably in the same room with the fixture they serve. Installation of vacuum breaking devices in utility or service spaces is also permitted, provided the devices are readily accessible.

**Local Law 69-1977.*

***As enacted but "1970" probably intended .*

P107.19 Approval of Devices.-Before any device for the prevention of backflow or back-siphonage is installed, it shall have first been tested and a test report showing compliance with the applicable standard shall have been filed by an architect or engineer, in accordance with the administrative provisions of the building code.

P107.20 Protection of Potable Water Supply Outlets.-

- (a) Backflow preventers or vacuum breakers shall be installed with any plumbing fixture or equipment in each potable water supply outlet that may be submerged and that cannot be protected by a minimum air gap, or as otherwise provided in this code. All submerged inlets, except for connections to water closet and urinal flushometer valves and ball floats for tank water closets and urinals, shall have a check valve installed between the vacuum breaker and the submerged inlet.
- (b) Type required.-
 - (1) CONNECTIONS NOT SUBJECT TO BACK PRESSURE.-Where a water connection is not subject to back pressure, a non-pressure type vacuum breaker shall be installed on the discharge side of the last valve on the line serving the fixture or equipment. A partial list of conditions requiring protective devices of this kind is given in Table RS 16-11. The critical level shall be indicated on the vacuum breaker, or in the event the critical level is not indicated, the lower end of the vacuum breaker body shall constitute the critical level.
 - (2) CONNECTIONS SUBJECT TO BACK PRESSURE.-Where a potable water connection is made to a line, fixture, tank, vat, pump, or other equipment with a hazard of backflow or back-siphonage where the water connection is subject to back pressure, a pressure type vacuum breaker and check valve shall be installed.

Reference Standard 16

TABLE RS 16-11 CROSS-CONNECTIONS WHERE PROTECTIVE DEVICES ARE REQUIRED AND CRITICAL LEVEL (C-L) SETTING FOR VACUUM BREAKERS

Fixture or Equipment	Methods of Installation
Dental Units	On models without built-in vacuum breakers - C-L at least 4 in. above flood rim of bowl.
Dishwashing machines	An air gap or with the C-L at least 4 in. above flood level of machine. Install on both hot and cold water supply line and on water supply to detergent or water softening appliances.
Flushometers (closet and urinal)	C-L at least 4 in. above top of fixture supplied.
Garbage can cleaning machine	C-L at least 4 in. above flood level of machine. Install on both hot and cold water supply lines.
Hose outlets, (except outside sillcocks, draincocks at base of water risers or at equipment, and fire hose outlets)	C-L at least 4 in. above highest point on hose line or as permitted by the commissioner.
Laundry machines	C-L at least 4 in. above flood level of machine. Install on both hot and cold water supply lines.
Lawn sprinklers	C-L at least 12 in. above highest sprinkler or discharge outlet. Installed on header at building wall.
Steam tables	C-L at least 4 in. above floor level.
Tanks and vats	C-L at least 6 in. above flood level rim or line.
Trough urinals	C-L at least 30 in. above perforated flush pipe.
Flush tanks	All flush tanks operated by ballcocks shall have a vacuum breaker located not less than 1 in. above the overflow outlet of the flush tank.

P107.21 Preheating Apparatus.-Water supply lines to water preheating apparatus utilizing waste water from the plumbing system shall be equipped with a vacuum breaker located at least 4 in. above the highest elevation of the preheating apparatus or coil, with a check valve between the vacuum breaker and the preheating apparatus. Any hot water boiler supplied through such preheating device and having an independent cold water supply line shall have the cold water supply line equipped with a vacuum breaker and check valve located at least 4 in. above the highest elevation of the boiler.

P107.23 Chemical Solution Tanks or Apparatus.-Direct water supply connections to any tank or apparatus containing any chemical shall be prohibited unless specifically approved by the department of health.

P107.24 Bedpan Washers.-Bedpan washers or similar apparatus not provided with an approved flushometer shall be equipped with a vacuum breaker and check valve. The check valve shall be located between the fixture and the vacuum breaker. Water supply to bedpan washers equipped with an approved flushometer valve shall be provided with a vacuum breaker. Bedpan washers may be equipped with steam connections only when such equipment has been approved.

P107.25 Laboratory Outlets.-Each laboratory outlet provided with a serrated tip or hose end shall be provided with a vacuum breaker.

***P107.26 Hot Water Supply System.**
(a) Return circulation-where required.

(1) Hot water supply systems, in buildings four stories or more in height, or buildings in which the developed length of hot water piping from the source of hot water supply to the farthest fixture supplied exceeds 50 ft. shall be of the return circulation type, except as otherwise provided in subparagraph (2) of this paragraph. No branch from a noncirculated riser or header shall exceed 50 ft.

(2) A temperature maintenance system with electric heaters and components applied to the domestic hot water piping may be used in lieu of a return circulation system provided:

a. The system conforms to the requirements of national standard ANSI/IEEE 515-1983.

b. The minimum predetermined temperature in the domestic hot water piping is not less than 100°F.

c. The minimum outlet temperature of the hot water supply source is not less than 110°F.

d. All heating cable cores are permanently marked with the manufacturer's batch or serial number for traceability and cable jackets are continuously and permanently marked with manufacturer's name, catalog number, nominal supply voltage and nominal power output in watts per ft. The use of temporary printing or tags shall not be permitted.

e. Test certificates accompany each reel of heating cable and are signed by the manufacturer's quality control officer. The certificates shall indicate the cable type, cable rating in watts per ft., voltage rating, test date, batch number, reel number, length of cable, test voltage and test amperage reading.

f. The system is listed for domestic hot water piping by an accepted nationally recognized independent laboratory that maintains periodic inspections of production of listed equipment and whose listing states that the

Reference Standard 16

equipment meets nationally recognized standards for domestic hot water piping.

g. The system is accepted and approved by the department of buildings.

(b) Pressure relief valves, temperature relief valves and energy cutoff devices required.-Equipment used for heating water or storing hot water shall be provided with one of the following safety devices:

A separate pressure relief valve and separate temperature relief valve.

A combination pressure and temperature relief valve.

(1) No check valve or shut-off valve shall be installed between the safety device and the hot water equipment used.

(2) Relief outlets or relief valves shall not be directly connected to drainage or vent piping.

(3) Relief valve discharge pipes shall be the same size as valve discharge connections and shall pitch downward from the valve to the point of disposal. Pipe shall terminate with an unthreaded end.

(4) Where a relief outlet discharges into a plumbing fixture, a minimum air break shall be provided.

(5) All relief valves and safety devices shall comply with the requirements of the applicable standards of the U.S.A. Standards Institute, American Society of Mechanical Engineers, or the Underwriters' Laboratories. Valves or devices shall be accepted for use in accordance with the administrative provisions of the building code.

(6) All new installations of equipment used for heating water or storing water shall comply with the provisions of subdivision P107.26 of Section P107.0 of Reference Standard RS-16.

(7) All replacements of equipment used for heating water or storing water shall comply with the provisions of subdivision P107.26 of Section P107.0 of Reference Standard RS-16.

(8) All existing equipment used for heating water or storing water shall comply with the provisions of paragraph (b) of subdivision P107.26 of Section P107.0 of Reference Standard RS-16.

(c) Pressure relief valves.-Pressure relief valves and the pressure relief element of combined pressure and temperature relief valves shall be in accordance with the requirements of the ASME boiler and pressure vessel code, 1962, Section IV and the construction requirements of USASI Z21.22-1964.

(1) Valve capacity, as rated from actual test data, shall be at least equal to the rated capacity of the connected heater or heaters.

(2) The opening pressure of the pressure relief valve shall be at least 25 lbs. above the normal working pressure in the system or the pressure delivered by the water pressure reducing valve. In no case shall the relief valve be set to open at a pressure above the rated working pressure of the vessel that the valve is installed to protect.

(d) Temperature relief valves.-Temperature relief valves shall have a relief rating, expressed in Btu per hour, equal to that of the equipment served. They shall be installed so that the temperature sensing element is immersed in the hottest water, such as:

(1) Within the top 6 in. of the tank of an unfired hot water storage heater;

(2) Above the hot water inlet to a tank equipped with a sidearm type water heater or supplied with hot water from another source;

(3) Above the topmost heating element of an electric water heater;

(4) Where, due to the construction of the water heater, there is no tapping to receive the temperature relief valve, the valve shall be installed in a tee following a nipple installed in the heater. The tee shall be located as close as possible to the heater jacket.

(e) Emergency energy cut-off devices.-The performance rating of emergency energy cut-off devices shall be equal to or greater than the performance rating for the equipment served. Immersion type energy cut-off devices shall be installed so that the temperature sensing element is immersed in the hottest water zone of the equipment served. Contact types shall be installed only when permitted by the Commissioner, and shall be rigidly mounted in contact with the shell of the water heater, shall be calibrated accurately for use on the heater to which it is applied, and shall be insulated or protected from flue gas, heat, or other ambient conditions that are not indicative of stored water temperature. Safety pilots or other approved devices shall be installed to cut off the main fuel supply to the main burner or heat producing equipment.

(f) Vacuum relief valves.-All copper lined tanks located and installed so that they can be drained by a fixture located below the tank shall be equipped with a vacuum relief valve that shall comply with USASI Z21.22-1964.

(g) Pressure marking of hot water storage tank.-Hot water storage tanks shall be permanently marked in a readily accessible place to indicate the maximum allowable working pressure, which shall be not more than 2/3 of the bursting pressure of the tank.

(h) Temperature limit controls.-All hot water heaters and storage tanks shall be equipped with an operating temperature limit control.

***** (i) Prohibited locations and usage of hot water generators.**-No solid or liquid fuel or gas fuel-fired water heater shall be installed in bathrooms, bedrooms, or in any enclosed space with a volume of less than 300 cu. ft.; nor shall vents designed only for use with gas equipment be used with solid or liquid fuel-fired equipment. Notwithstanding the foregoing, a gas fuel-fired water heater may be installed in any dwelling unit in accordance with the following conditions:

(1) The enclosed space shall have a minimum volume of at least 100 cu. ft.;

(2) The maximum BTU rating shall be 75,000 BTU/hr.;

(3) There shall be a fresh air intake which shall equal at least one sq. inch free area per 2000 BTU/hr. input rating which in no event shall be less in cross-section than the flue projecting from the hot water heater and which shall be fire damper protected if used for air supply duct work of two or more stories;

(4) The exhaust from the water heater shall be connected to an approved type flue;

(5) The installation shall be made within a solid

Reference Standard 16

enclosure with a flush door without louvres, and with clearances about the water heater conforming to A.G.A. requirements, and

(6) The heater shall be (i) currently listed by an independent laboratory acceptable to the commissioner pursuant to section C26-106.2, (ii) approved by the department and (iii) approved by the department of health.

**Local Law 82-1986; Local Law 67-1977*

****Local Law 45-1984*

P107.27 Disinfection of Potable Water Systems.-

(a) New or repaired potable water systems shall be disinfected prior to use whenever samples from the system show any contamination after making a bacteriological examination. Samples shall be taken as required by the department of health. The method to be followed shall be that as prescribed by the department of health, or where no method is prescribed by the department of health, by the following:

(1) The pipe system shall be flushed with clean, potable water until no dirty water appears at the outlets.

(2) The system or part thereof shall be filled with a water-chlorine solution containing at least 50 parts per million of chlorine and the system or part thereof shall be valved off and allowed to stand for 24 hr. or, the system or part thereof shall be filled with a water-chlorine solution containing at least 200 parts per million of chlorine and allowed to stand for 3 hr.

(3) Following the prescribed standing time, the system shall be flushed with clean potable water until no excess chlorine remains in the water coming from the system.

(4) The procedure shall be repeated if it is shown that contamination still persists in the system.

Section P108.0 Sanitary Drainage Piping

P108.1 Permits.-

(a) Permits for the installation of a building house storm sewer from the street line to and including the spur connection at the street sewer shall be obtained in accordance with the requirements of the building code.

P108.2 Street Sewer Connections.-

(a) Any connection to a sewer, other than a pipe sewer, shall in no case have its inner top lower than 6 in. below the inner top of the sewer.

(b) All building sewer connections to a street arch or circular sewer shall be at a point 45 degrees to the horizontal plane in the upper quadrant of the street arch or circular sewer except as otherwise directed by the department of public works.

******(c) All building house sewer connections shall be made in the presence of an employee of the department.

(d) All building sewer connections shall be flush with the inside face of the wall of the street sewer.

(e) No building sewer connections shall be made to catch basins or drain inlets.

***Local Law 65-1996*

P108.3 Abandonment of Existing Building Sewer Connections.-

(a) All abandoned building sewers shall be securely sealed at a point inside the curb line and as close thereto as practicable.

P108.4 Building (House) Traps.-

(a) Building (house) traps shall be installed as prescribed in Section P105.0.

(b) A building (house) trap shall not be required on a sub-house drainage system that discharges into a sewer ejector pit or sump pit.

P108.5 Fresh Air Inlets.-Every sanitary or combined building (house) drain equipped with a building (house) trap, sewage pump, ejector, receiving tank, oil separator, or similar equipment, shall be provided with a fresh air inlet pipe connected to the building house drain immediately upstream from, and within 4 ft. of, such trap or equipment. Such connection shall be made in the same manner as prescribed herein for vent connections to horizontal drains, and the fresh air inlet pipe shall be extended to the outer air and shall be terminated in an open end at least 6 in. above grade. The open end shall be protected by a perforated metal plate permanently fixed in the mouth of the inlet and having an open ventilating area at least equal to the area of the pipe, or by a return bend with its unprotected open end at least 6 in. above grade located inside the street line. The size of the fresh air inlet pipe shall be at least 1/2 the diameter of the building drain at the point of connection, but not less than 3 in.

P108.6 Drainage Below Sewer Level.-

(a) Drainage from parts of the drainage system that cannot drain into the gravity system or, where the plumbing design does not indicate drainage into the gravity system, shall be disposed of through sub-building (sub-house) drainage systems. The discharge from the ejector or sump pit shall be through a connection located on the street side of the building house trap. The discharge from non-vented, clear water sumps may be connected to any point in the gravity drainage system.

(b) Drainage and vent piping of sanitary building sub-house drainage systems shall be installed in the same manner as for gravity systems. The vents of the building sub-house drainage system may be connected to the vents of the gravity drainage system provided such connection is made above the overflow rim of the lowest fixture on the gravity system.

(c) Sump pits or receiving tanks receiving the discharge from the sanitary drainage or from the building sub-house sanitary drainage system shall be airtight and provided with a vent. Sump pits or receiving tanks that do not receive the discharge of domestic sewage, but receive only clear water from floor drains or machinery drips, need not be air-tight and vented.

(d) Each sewage receiving tank or pit shall be provided

Reference Standard 16

with a vent that is sized on the basis of one fixture unit for each gpm flow of the discharge pumps and the developed length of the vent from the receiver to the vent stack or the outside air, in accordance with Table RS 16-14. The vent from a receiving tank may be connected to the gravity drainage vent system provided such system is 3 in. or larger.

(e) The relief devices of a pneumatic sewage ejector system shall be connected to an independent relief line vent at least 3 in. in diameter. Such vent shall be carried independently through a roof and shall terminate as required for sanitary vent stacks or stack vents. The mechanism for the relief of the air pressure in the closed sewage receptacle shall have valves, piping, and connection that form a part of the sewage ejector device. The devices shall be sufficient in size to relieve the ejector pit to atmospheric pressure in not more than 10 sec., and the minimum size of such valves and piping shall be 1 1/4 in.

(f) Sump pits or receiving tanks may be constructed of concrete provided the compartment is fully waterproofed and the walls of the pit troweled to a smooth finish.

(g) Each sewage ejector or sump discharge shall be provided with a check valve and a gate valve.

P108.7 Sub-Soil Drainage.-Where sub-soil drainage is to be discharged to a public sewer, the sub-soil drains shall discharge into a readily accessible silt and sand interceptor designed by an architect or engineer, the drainage from which shall be disposed of into the gravity drainage system or a sump system. Where the piping from the interceptor is directly connected to the gravity drainage system, such piping shall be provided with an approved and readily accessible backwater valve and shall be connected upstream of a leader or area drain trap. Area drains may be connected to the sub-soil drainage system subject to the provisions of Section P110.2.

P108.8 Drainage Piping Installation.-

(a) **Pitch of horizontal drainage piping.**-Horizontal drainage piping shall be installed in uniform alignment at uniform slopes as follows:

Size of Piping	Minimum Slope
2 in. or less	1/4 in. per ft.
Over 2 in.	1/8 in. per ft.

(b) Change of direction.-

(1) Changes in direction in drainage piping shall be made by the appropriate use of 45 degrees wyees; long sweeps; short sweeps, quarter, sixth, eighth, or sixteenth

bends; or by a combination of these or equivalent fittings.

(2) Sanitary tees and quarter bends may be used in drainage lines only where the direction of flow is from the horizontal to the vertical.

(3) Short sweeps will be permitted in drainage piping 3 in. in diameter or larger for any offsets either horizontal or vertical.

(c) Prohibited fittings and connections.-

(1) No running threads, bands, or saddles shall be used in drainage or vent piping. No drainage or vent pipes shall be drilled or tapped.

(2) No fitting, connection, device, or method of installation that retards the flow of water, wastes, sewage, or air in the drainage or vent systems to an extent greater than the normal frictional resistance to flow shall be installed. Double hubs are prohibited for use in drainage piping. No fitting having a hub faced downstream shall be used as a drainage fitting. No tee branch of a drainage fitting shall be used as an inlet branch for wastes. Double sanitary tees may not be used for a fixture connection when a blowout type fixture is connected to one of the inlets.

(3) A heel- or side-inlet quarter bend shall not be used as a vent connection fitting in drainage piping when the heel- or side-inlet is placed in a horizontal position.

(4) The expanding or swedging of 3 in. lead bends or stubs to 4 in. size, thereby causing a reduction in pipe wall thickness, is prohibited. Approved 3 in. x 4 in. lead bends and stubs with uniformly proper wall thickness may be used for connections to 4 in. floor flanges, and 4 in. x 3 in. floor flanges may be used for connection to 3 in. lead bends and stubs.

(d) **Dead ends.**-In the installation of removal or any part of a drainage or vent system, dead ends shall be avoided except where necessary to extend a cleanout so as to be accessible.

(e) **Provision for future fixtures.**-Drainage and vent piping provisions for future fixture installations shall consist of plugged fittings at the stack, or of piping installed without dead ends.

P108.9 Sanitary Drainage Fixture Units.-

(a) **Value for fixtures.**-Fixture unit values given in Table RS 16-12 shall be employed in computing the total load carried by a soil or waste pipe and shall be used with the tables for sizing soil, waste, drainage, and vent pipes.

(b) **Values for continuous or semicontinuous flow.**-Fixture unit values for continuous or semicontinuous flow into a drainage system, such as from a pump, ejector, air-conditioning equipment, or similar devices shall be computed on the basis of one fixture unit for each gpm of flow.

TABLE RS 16-12 SANITARY DRAINAGE FIXTURE UNIT VALUES ^a

Fixture or Group	Fixture Unit Value
Automatic clothes washer (2 in. standpipe)	3
Bathroom group consisting of a lavatory, bathtub or shower stall, and a water closet (direct flushometer valve)	8
Bathroom group consisting of a lavatory, bathtub or shower stall, and a water closet (flush tank)	6
Bathtub with or without overhead shower	2
Combination sink and wash tray	3
Dental unit or cuspidor	1
Dental lavatory	1
Drinking fountain	1/2
Dishwasher, domestic type	2
Floor drain	2 ^{b*}
Kitchen sink, domestic type	2
Lavatory	1
Lavatory (barber shop, beauty parlor or surgeon's)	2
Lavatory, multiple type (wash fountain or wash sink), per each equivalent lavatory unit or set of faucets	2
Laboratory cup sink	1
Laboratory sink	2
Laundry tray (1 or 2 compartment)	2
Shower stall	2
Shower (group) per head	2
Sink (surgeon's)	3
Sink (flushing rim type, direct flush valve)	6
Sink (service type with trap standard)	3
Sink (service type with P trap)	2
Sink (pot, scullery, or similar type)	4
Urinal (1 in. flush valve) pedestal	6
Urinal (3/4 in. flush valve) stall or wall hung	4
Urinal (flush tank)	4
Water closet (direct flush valve)	6
Water closet (flush tank)	4
Unlisted fixture, 1 1/4 in. fixture drain and 1 1/2 in. trap size	1
Unlisted fixture, 1 1/2 in. fixture drain or trap size	2
Unlisted fixture, 2 in. fixture drain or trap size	3
Unlisted fixture, 2 1/2 in. fixture drain or trap size	4
Unlisted fixture, 3 in. fixture drain or trap size	5
Unlisted fixture, 4 in. fixture drain or trap size	6

Note-

^a See section P108.9(b) for method of computing unit values for devices with continuous or semicontinuous flows.

^b Any floor drains provided in an elevator vestibule or in an elevator shaft shall be excluded from being counted as fixture units.

*Local Law 26-2004.

P108.10 Sizing the Sanitary Drainage Piping.-

(a) Drainage piping.-Sizes shall not be less than those permitted in Table RS 16-13, using the fixture unit values of Table RS 16-12.

(b) Sewer piping.-When more than one building house drain discharges into a private sewer within the property line, the sewer may be sized on a design basis and the slope of the sewer shall be predicated on the size selected, but in no case shall the slope be less than that required to produce a velocity in the sewer of less than 3 fps.

(c) Minimum size of soil and waste stacks.-No soil or waste stack shall be smaller than the largest horizontal branch connected thereto, except that a 4 in. x 3 in. water closet connection shall not be considered as a reduction in pipe size.

(d) Provision for future fixtures.-When provision is made for the future installation of fixtures, those provided for shall be considered in determining the required sizes of drain and vent pipes.

(e) Minimum size of underground drainage piping.-No portion of the drainage system installed underground or below a basement or cellar floor on ground shall be

less than 2 in. in diameter, except that drip pipes may be 1 in. if of copper or brass.

(f) Sizing of offsets in drainage piping.-

(1) OFFSETS OF 45 DEGREES OR LESS.-An offset in a vertical stack, with a change of direction of 45 degrees or less from the vertical, may be sized as a straight vertical stack.

(2) OFFSETS OF MORE THAN 45 DEGREES.-A stack with an offset of more than 45 degrees from the vertical shall be sized as follows:

a. The portion of the stack above the highest offset shall be sized as required for a regular stack based on the total number of fixture units above the offset.

b. The offset shall be sized as required for a building house drain (Table RS 16-13).

c. The portion of the stack below the offset shall be sized the same as the offset or based on the total number of fixture units on the entire stack, whichever is the larger.

d. A relief vent for the offset shall be installed as provided in section P109.12 and in no case shall a horizontal branch drain connect to the stack within 2 ft.

Reference Standard 16

above or below the offset.

(3) **OFFSETS ABOVE HIGHEST BRANCH.**-An offset in the stack vent above the highest horizontal branch shall be considered only as it affects the developed length of the vent. The horizontal offset and piping above the stack vent offset shall be of a non-scaling material.

(4) **OFFSETS BELOW LOWEST BRANCH.**-In the case of an offset in a soil or waste stack below the lowest horizontal branch, there shall be no change in diameter required if the offset is made at an angle of 45 degrees or less from the vertical. If such an offset is made at an angle greater than 45 degrees from the vertical, the required

diameter of the offset and the stack below it shall be determined as required for a building house drain.

(5) **OFFSETS PROHIBITED.**-No offset in a soil or waste line shall be made directly above any equipment used to prepare or store any food products, except where provided with protection from drips with a water tight copper pan extending 4 in. in each direction from the pipe wall and turned up at least 1/2 the diameter of the pipe but not less than 2 in. The pan shall extend at least 1 ft. beyond the fixtures or tables. Other methods may be used when permitted by the commissioner.

TABLE RS 16-13 MAXIMUM PERMISSIBLE LOADS FOR SANITARY DRAINAGE PIPING (IN TERMS OF FIXTURE UNITS)

Pipe Diameter (in.)	Any horizontal branch or fixture at one story of stack	Total for Stack	House building Drain, and Building Branches from stacks			
			Slope (in. per ft.)			
			1/16	1/8	1/4	1/2
1 1/2 ^a	3	4	np	np	np	np
2 ^a	6	8	np	np	21	26
2 1/2 ^a	12	30	np	np	24	31
3	20 ^b	97 ^b	np	20 ^b	27 ^b	36 ^b
4	160	507	np	180	216	250
5	360	1445	np	390	480	575
6	2918	np	700	840	1000
8	6992	1440	1600	1920	2300
10	2500	2900	3500	4200
12	3900	4600	5600	6700

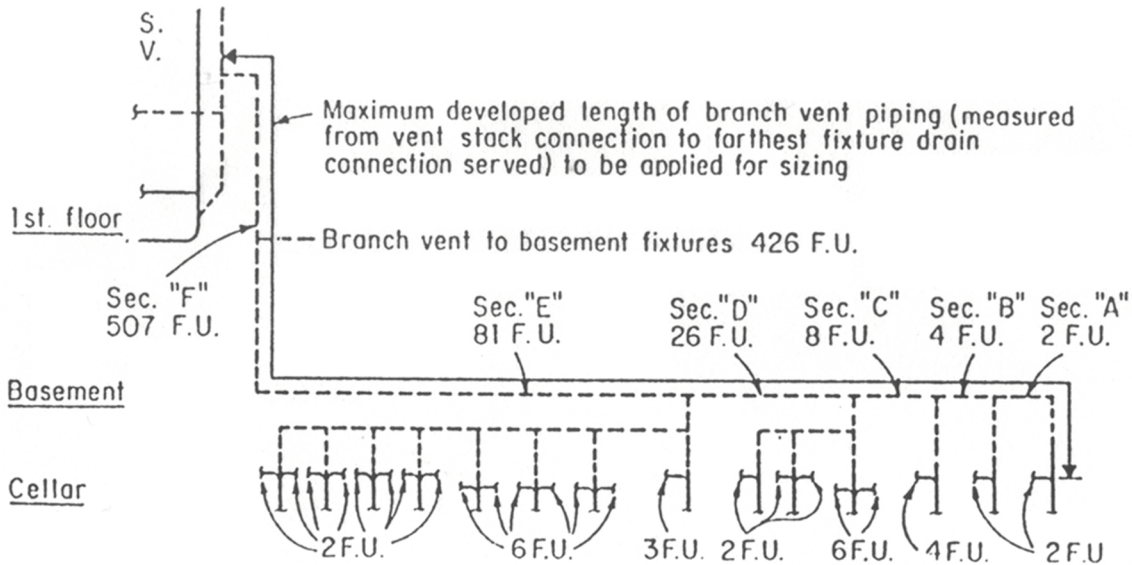

SIZING SCHEDULE Max. developed length-70'		
BRANCH VENT SECTION	LOAD (F.U.)	SIZE (IN.)
A	2	1 1/2
B	4	1 1/2
C	8	2
D	26	2
E	81	2 1/2
F	507	3

SIZING SCHEDULE Max. developed length-200'		
BRANCH VENT SECTION	LOAD (F.U.)	SIZE (IN.)
A	2	1 1/2
B	4	2
C	8	2 1/2
D	26	3
E	81	3
F	507	4

Figure RS 16-2. Sizing of Branch Vent Piping, Drop Vents to 1st Floor, Basement and Cellar Fixtures.

Reference Standard 16

Notes-

^a No water closets permitted.

^b Not over two water closets permitted.

np = not permitted.

P108.11 Drip Pipes.-Drips from pump bases, air conditioning drips, and similar clear water drips may be collected into a 1 in. pipe, and the pipe may be connected to the inlet side of a floor drain trap. Piping underground shall be of brass or copper.

Section P109.0 Vent Piping

P109.1 Size of Vents.-The nominal size of vent piping including vent headers shall be determined from its length and the total number of fixture units connected thereto, as provided in Table RS 16-14. In no case however, shall the nominal size be less than the following:

(a) **Individual vent.**-1 1/2 in. or 1/2 the diameter of the drainage pipe to which it is connected, whichever is greater.

(b) **Relief vent.**-1 1/2 in. or 1/2 the diameter of the soil or waste branch to which it is connected, whichever is greater.

(c) **Branch vents.**-Branch vents connecting more than one individual vent to a stack or stack-vent shall be in

accordance with Table RS 16-14. The branch vent size shall be based upon the number of fixture units connected thereto, and the developed length of the branch vent measured from its vent stack (or stack-vent) connection to the farthest fixture drain connection served by the branch vent. See Figure RS 16-2.

(d) **Vent stacks.**-The developed length of a vent stack shall be measured from the base or point of connection with the attending soil or waste stack to the connection with a vent header or its termination above the roof. Stacks shall be sized in accordance with Table RS 16-14.

P109.2 Protection of Trap Seals.-The protection of trap seals from siphonage or back pressure shall be accomplished by the use of soil or waste stacks, vents, revents, back vents, continuous vents, or combinations thereof, installed in accordance with the requirements of this code, so that at no time shall the trap-seal be subjected to a pressure differential of more than 1 in. of water.

TABLE RS 16-14 SIZE OF VENT STACKS AND BRANCH VENTS

Size of soil (in.) or waste stack	Fixture units Connected	Diameter of vent required (in.)								
		1 1/2	2	2 1/2	3	4	5	6	8	10
		Maximum developed length of vent (ft.)**								
1 1/2.....	4	100	†
2.....	8	30	170	†
2 1/2.....	30	15	70	175	†
3.....	97	6	24	89	250	†
4.....	507	*	*	11	78	310	†
5.....	1445	*	*	*	16	110	380	†
6.....	2918	*	*	*	*	34	143	380	†	..
8.....	6992	*	*	*	*	*	14	73	340	†
10.....	...	*	*	*	*	*	*	*	*	†

Notes-

*not permitted.

**A 1 1/2 in. vent may be used for 6 or less fixture units for a developed length of 15 ft. from the fixture to header regardless of developed length limiting the header size.

† unlimited

P109.3 Vent Stack and Stack Vents.-

(a) **Minimum size.**-Any building in which a building drain is installed shall have at least one 4 in. vent stack (or stack-vent) carried full size through the roof.

(b) **Vent stack required.**-Every building in which plumbing is installed shall have at least one 4 in. main stack or stack-vent, which shall run undiminished in size and as directly as possible, from the building drain through to the outdoor air above the roof. A vent stack shall be installed in conjunction with each soil or waste stack in a building containing three or more branch intervals; however, one vent stack may serve not more than two soil or waste stacks.

(c) **Connections at base and top.**-All main vents or vent stacks shall connect full size at their base to the building drain or to the soil or waste stack at or below the level of the lowest drainage connection to the soil or waste stack. All vent stacks shall extend undiminished

in size above the roof, or shall be reconnected to a vent header, or to the stack vent portion of the soil or waste stack, at least 6 in. above the flood level of the highest fixture connection discharging into the soil or waste stack.

(d) **Angle of offsets and connections.**-Offsets in the stack vent portion of soil and waste stacks (above the highest fixture drainage connection), offsets in vent stacks, and connections of vent stacks at the bottom to a soil or waste pipe or to the building house drain, shall be made at an angle of at least 45 degrees to the horizontal. However, where provision is made to wash out the scale above the offset or where the entire piping above such offsets is of nonscaling type, the offset angle may be reduced, provided there is sufficient slope for condensation to drain back to soil or waste pipe connections.

(e) **Vent headers.**-Where stack vents and vent stacks are connected into a vent header, such connections shall be made at the tops of the stacks. The vent header shall

Reference Standard 16

connect to a vent extension through the roof. The vent header material shall be of non-scaling type.

(f) Sub-stack connections.-Where it is desired to terminate stacks at a point below the roof terminus of the main vent stack, the sub-stack may connect to the main vent stack provided the portion of the main vent stack above the connection is sized for the total fixture unit load connected thereto, and for the maximum developed length of the stack or sub-stack.

P109.4 Vent Terminals.-

(a) Extension above roofs.-Extension of vent pipes through a roof shall be terminated at least 24 in. above the roof surface. Where a roof is to be used for any purpose other than weather protection, the vent extensions shall be run at least 7 ft. above the roof surface.

(b) Size of vent extension.-Each vent extension shall be at least as large as the soil stack, waste stack, vent stack, or vent header served thereby, but in no case less than 4 in. size. Where it is necessary to increase the size of a vent pipe at its vent extension, the change in size shall be made by use of a long increaser immediately below the roof.

(c) Waterproof flashings.-Each vent terminal shall be made watertight by proper flashing.

(d) Attachments prohibited.-Vent terminals shall not be used for the purpose of attaching flag poles, television aerials, or for similar purposes.

(e) Location of vent terminal.-

(1) No vent terminal shall be located directly beneath any door, operable window, or other ventilating opening of the building or of an adjacent building, nor shall any such vent terminal be within 10 ft. horizontally of such an opening unless it is at least 3 ft. above the top of such opening.

(2) Vent extensions shall not be run through an exterior wall.

(f) Extensions outside building.-No soil, waste, or vent pipe extension shall be run or placed on the outside of a wall of any building, unless such exterior installation on penthouses is permitted by the commissioner.

P109.5 Vent Grading and Connections.-

(a) Vent grading.-All vent and branch vent pipes shall be so graded and connected as to drain back to the soil or waste pipe by gravity.

(b) Height above fixtures.-

(1) A connection between a vent pipe and a vent stack or stack vent shall be made at least 6 in. above the flood-level rim of the highest fixture served by the vent. Horizontal vent pipes forming branch vents or relief vents shall be at least 6 in. above the floor-level rim of the highest fixture served.

(2) See Figure RS 16-4 for typical methods of compliance.

P109.6 Stack Venting.-

(a) Highest fixture connection to soil or waste stack.-Where a fixture discharges directly into a soil or waste stack at a level above all other drain connections thereto, the stack vent may serve as the vent for the fixture trap provided that:

(1) Such vent connection is above the level of the dip of the trap (except for fixture drains of floor-outlet type water closets and urinals, and of floor-outlet type trap standards for service sink);

(2) Such vent connection is within the distance permitted in this standard.

P109.7 Common Vents.-

A common vent may serve as an individual vent for not more than two fixture traps. Such common vent shall connect at the junction of the two fixture drains and shall rise vertically from the connection before offsetting horizontally.

P109.8 Fixture Vents.-

(a) Distance of trap from vent.-Each fixture trap shall have a protecting vent so located that the developed length of the fixture drain from the trap weir to the vent fitting is not more than 2 ft. 0 in.

(b) Vent location.-The vent pipe opening from a soil

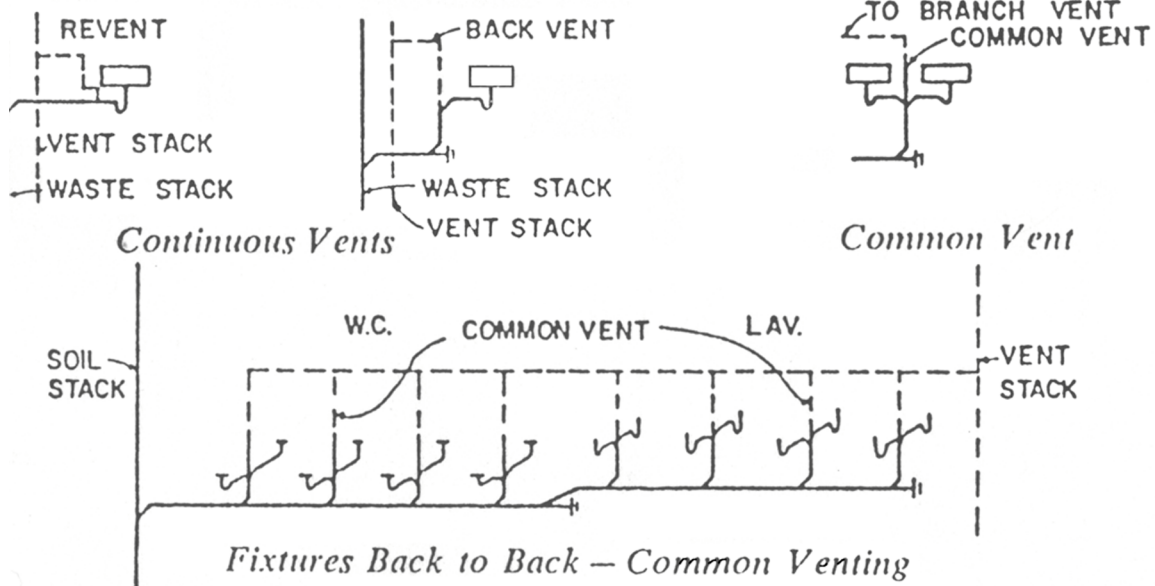

Fixtures Back to Back - Common Venting
Figure RS 16-4. Vent Arrangements.

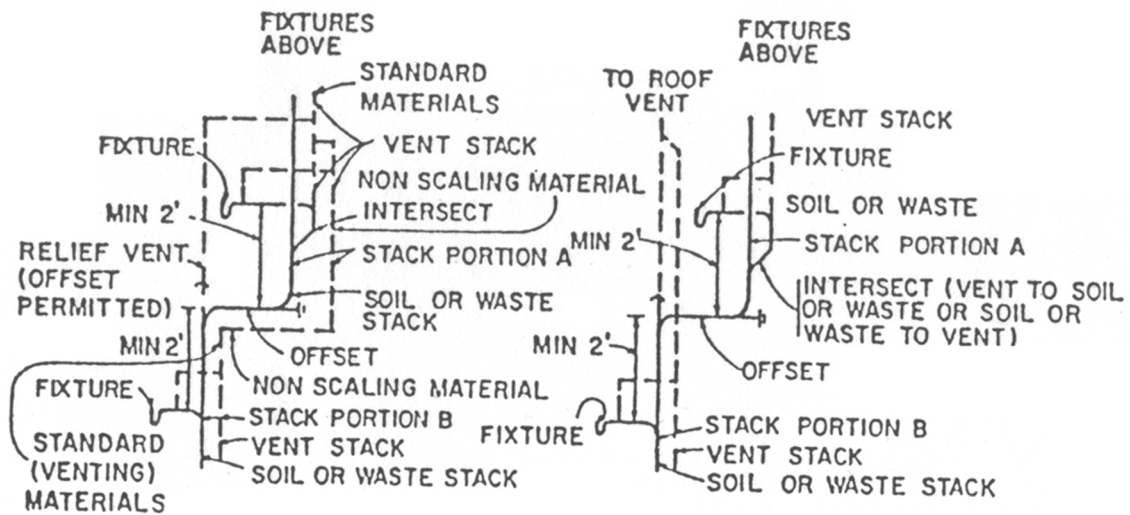

Figure RS 16-6. Offsets in Buildings Five Stories or More.

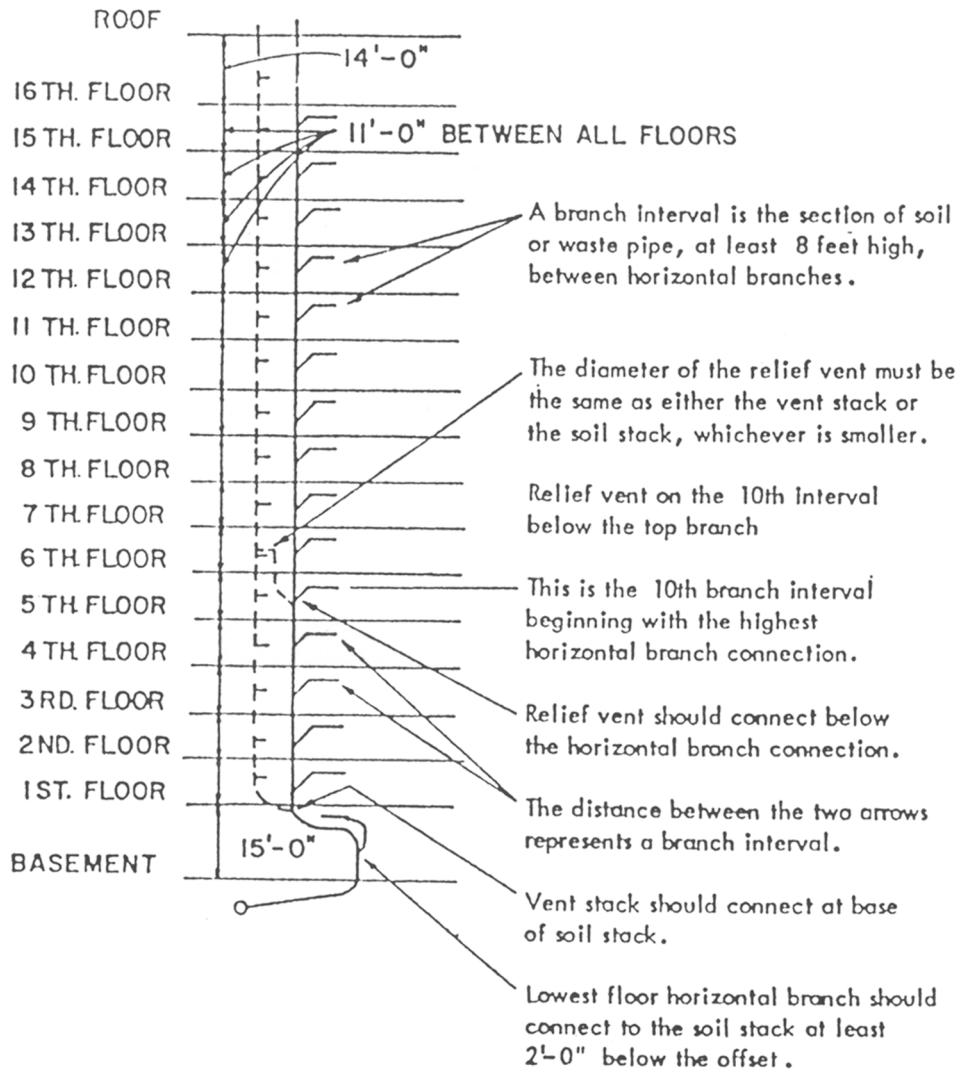

Figure RS 16-7. Relief Vents for Stack of More Than Ten Branch Intervals.

Reference Standard 16

or waste pipe, except for water closets and similar fixtures, shall not be below the weir of the trap.

(c) Crown venting prohibited.-No vent shall be installed within two pipe diameters of the trap weir.

(d) Floor drain vents.-No vents will be required for piping serving floor drains when the floor drain is located not more than 15 ft. 0 in. from a vented line.

P109.9 Relief Vents.-

(a) Vertical offsets in building drains.-Where an offset between horizontal portions of the building house drain rises vertically more than 10 ft. a relief vent shall be provided at the top of the vertical offset. The size of such relief vent shall be at least 1/2 the diameter of the building house drain at the offset and at a sufficient height so that the relief vents cannot serve as soil or waste pipes in the event of a stoppage in the vertical offset. See Figure RS 16-6 for typical installation.

(b) Soil and waste stacks more than ten stories high.-Soil and waste stacks more than ten stories high shall be provided with a yoke relief vent at each tenth story, counting from the top story. The lower end of the yoke vent shall connect to the soil or waste stack through a wye located below the horizontal branch drain serving fixtures in that story, and the upper end shall connect to the vent stack through a tee or inverted wye at least 3 ft. above the floor level. See Figure RS 16-7 for typical installation.

P109.10 Suds Pressure Zones Vents.-

(a) Where sinks, laundry trays, laundry washing machines, bathtubs, and similar fixtures in which sudsy detergents are normally used and discharged at an upper floor level into a soil or waste stack that also serves fixtures in other occupancy units at a lower floor

level, the drainage and vent piping for such lower fixtures shall be arranged so as to avoid connection to suds pressure zones in the sanitary drainage and vent systems. If connected to the sanitary system, a suds relief vent relieving to a nonpressure zone shall be provided at each suds pressure zone where such connections are installed. The size of such relief vent shall be at least 3/4 the diameter of the piping in which the pressure zone occurs, but not less than 2 in.

(b) Suds pressure zones shall be considered to exist at the following locations in sanitary drainage and vent systems when the piping serves fixtures on two or more

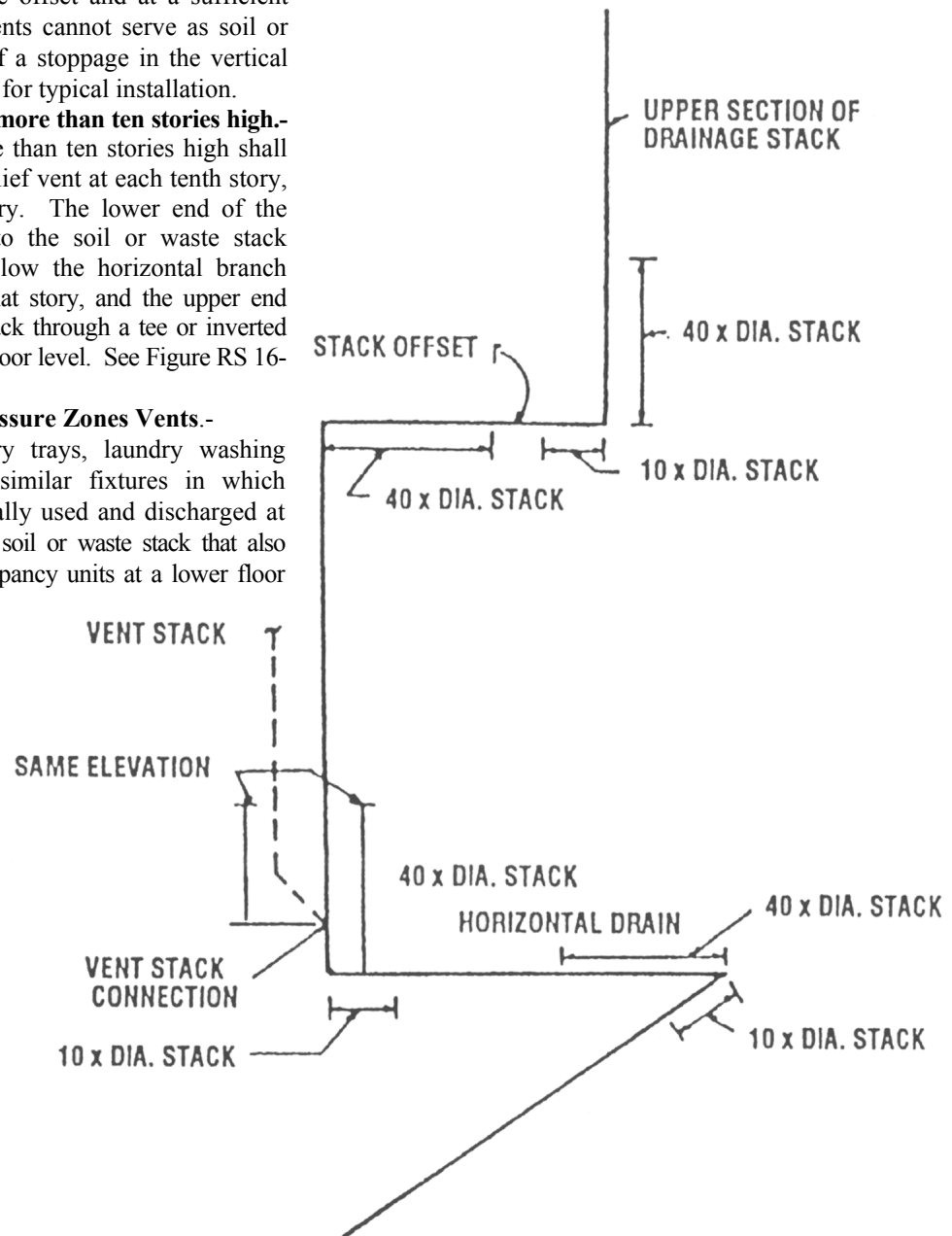

Figure RS 16-8. Suds Pressure Zones.

Reference Standard 16

floors that receive wastes that contain sudsy detergents. See Figure RS 16-8 for location of suds pressure zones.

(1) In a soil or waste stack a zone shall be considered to exist in the vertical portion within 40 stack diameters of the base fitting. (2) In the horizontal drain at the base of a soil or waste stack a zone shall be considered to exist in the horizontal portion within ten stack diameters of the base fitting. Where a 60 degree or 90 degree fitting is installed in the horizontal drain, a zone shall be considered to exist in the horizontal portion within 40 drain diameters upstream of and 10 drain diameters downstream of the fitting.

(3) In a soil or waste stack offset of 60 degrees or 90 degrees, a zone shall be considered to exist in the vertical portion of the stack within 40 stack diameters of the base fitting for the upper section of the stack. The zone shall be considered to exist in the horizontal offset within 10 stack diameters of such base fitting and within 40 stack diameters of the top fitting for the lower section of the stack.

(4) In a vent stack that has its base connected to a suds pressure zone in the sanitary drainage system, a zone shall be considered to exist in the portion of the vent stack extending from its base connection up to the lowest branch vent fitting located above the level of the suds pressure zone in the sanitary drainage system.

P109.11 Permitted Combination Waste and Vent Systems.-A combination waste and vent piping system, limited for use as a means of venting the traps of floor drains and laboratory sinks, shall be permitted in conjunction with horizontal branch waste piping of an independent flammable oil waste system or acid waste systems, and as described under indirect wastes and special wastes. See Figure RS 16-9 for typical installation.

Section P110.0 Storm Drainage Piping

P110.1 Permits.-

(a) Permits for the installation of a building house storm sewer from the street line to, and including the spur connection at the street sewer shall be obtained in accordance with the requirements of the building code. Street sewer connections shall be made as provided in Section P108.2(a), (b), (c) and (d).

***P110.2 Disposal of Storm Water.-**

(a) Definitions.-As used in this section:

(1) "Block" means a tract of land bounded by streets, public parks, railroad rights-of-way when located at or above ground level but not including sidings or spurs within a lot in the same ownership as the lot, airport boundaries, pierhead lines or shore lines, where no pierced lines have been established, or corporate boundary lines of New York city;

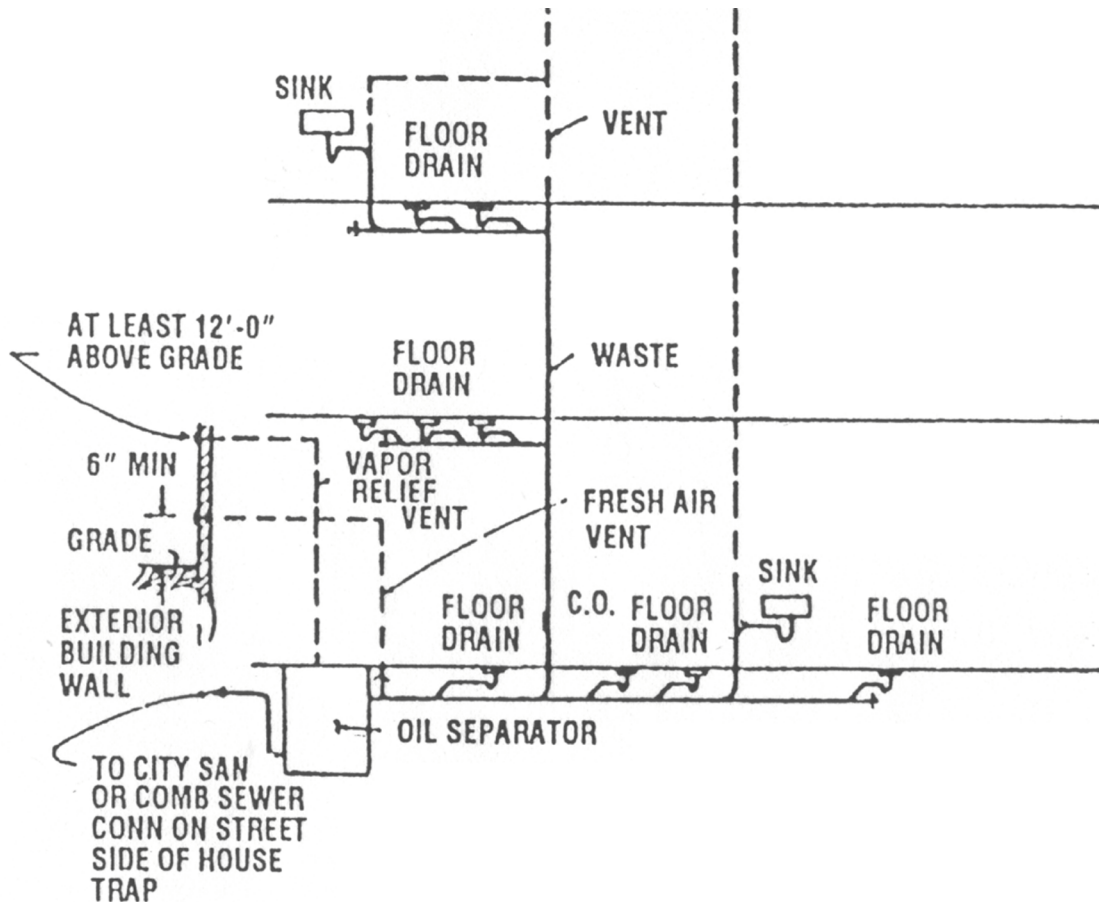

Figure RS 16-9. Combination Waste and Vent Oil Waste Drainage.

Reference Standard 16

- (2) "Building combined sewer" means a building sewer intended to convey all types of wastewater, subject to certain restrictions;
- (3) "Building sewer" means a sewer consisting of the part of the horizontal piping of a drainage system that extends from the end of a building house drain, as defined in section P100.00 of reference standard RS-16 of this code, to a street sewer or to another point of disposal. Building combined sewers and building storm sewers are types of building sewers;
- (4) "Building storm sewer" means that part of the horizontal piping of a storm water drainage system that extends from a building house storm drain, as defined in section P100.00 of reference standard RS-16 of this code, to a street storm sewer, a street combined sewer or another point of disposal;
- (5) "Catch basin" means a storm water inlet connected to a storm sewer or a combined sewer;
- (6) "Commissioner" means the commissioner of the department of buildings or his or her designee;
- (7) "Development" means a tract of land which has been subdivided into two or more lots, whether or not such tract has been developed as by the installation of any utilities or the construction of any streets or buildings or other structures;
- (8) "Impermeable soil" means soil of classes 1-65, 2-65, 3-65, 4-65, 5-65, 9-65, 10-65 or 11-65, as set forth in section 27-675 and table 11-2 of this code. Uncontrolled fill, as described in section 27-679 of this code, shall be considered impermeable soil;
- (9) "Impervious surfaces" means those areas of a lot or development covered by roofs, terraces, outside balconies, canopies, or paved surfaces such as driveways, sidewalks, courts, streets, or parking areas. A surface paved with an accepted asphalt or other acceptable material which, after compaction, is not thicker than one and one-half inches shall not be considered impervious, provided such surface will pass an amount of water equivalent to one-half inch of rainfall per hour and is underlaid by permeable soil;
- (10) "Lot" means a portion or parcel of land considered as a unit; a zoning lot;
- (11) "Owner" means a person in whom legal or equitable title to property or premises is vested, a mortgagee or vendee in possession of premises, an assignee of rents, a receiver of premises or a person listed as owner or agent for an owner on the records as to real property ownership maintained by the bureau of city collections of the department of finance unless such person establishes that such records are erroneous or, if claiming that he is an agent of the owner, furnishes the identity of the owner;
- (12) "Permeable soil" means soil at least five feet in depth of classes 6-65, 7-65, or 8-65, as set forth in section 27-675 and table 11-2 of this code, or porous material as determined by percolation tests. Controlled fill, as described in section 27-679 of this code, shall be considered permeable soil;
- (13) "Person" means a natural person, company, partnership, corporation, association, governmental body or other legal entity, including any individual or entity acting in a representative capacity;
- (14) "Private" means not public;
- (15) "Public" means owned by the city and intended for use by the public, subject to restrictions which the city or agencies thereof may impose;
- (16) "Storm water" means rain water or surface water;
- (17) "Street combined sewer" means a street sewer which is intended to receive the discharge of all types of wastewater, subject to certain restrictions, from one or more building sewers and catch basins and to convey such wastewater to an intercepting sewer, a private sewage disposal system or some other point of disposal;
- (18) "Street sewer" means a sewer located in the bed of a street or elsewhere which is intended to receive the discharge of all or certain types of wastewater from one or more building sewers and, in some cases, from catch basins, and to convey such wastewater to points of disposal. Street combined sewers and street storm sewers are types of street sewers;
- (19) "Street storm sewer" means a street sewer which is intended to receive the discharge of storm water from one or more building storm sewers and catch basins and to convey such storm water to a point of disposal;
- (20) "Substantial horizontal enlargement" means (a) an increase in the area of a lot covered by impervious surfaces which exceeds twenty percent of the existing area so covered, provided that the existing and enlarged areas so covered exceed one thousand square feet in total, or (b) an increase in the area of a lot covered by impervious surfaces which exceeds two hundred square feet, provided that the commissioner has previously approved the discharge of storm water from a building located on such lot by means of splash blocks; and
- (21) "Tidal creek" means any creek where the level of water rises and falls with tidal action, or would do so if not impeded by artificial structures including but not limited to tide gates.
- ** (b) Disposal of storm water when public sewers are located in front of the property.**-Where any new building or other substantial horizontal enlargement is to be constructed on a lot and the department determines that a public street storm sewer or public street combined sewer is located directly in front of any point of any boundary of such lot and that it would be feasible, pursuant to subdivision (j) of this section, to discharge storm water from such lot into such street storm sewer or street combined sewer, the owner of such lot shall ensure that all storm water falling or coming to rest on all impervious surfaces within such lot will be discharged to such street storm sewer or street combined sewer. Such discharge shall be by means of building storm sewers or building combined sewers, provided that no sewage shall be discharged into a public street storm sewer. If the department determines that such street storm sewer or street combined sewer has partial capacity to receive the storm water discharged from such lot, the remainder of such storm water shall be discharged pursuant to subdivision (c) of this section.
- ** (c) Disposal of storm water when public sewers are not located in front of the property.**-Where any new building or other substantial horizontal enlargement is to be constructed on a property and the department

Reference Standard 16

determines that no public street storm sewer or public street combined sewer is located directly in front of any point of any boundary of such property, the owner of such property shall ensure that all water falling or coming to rest on all impervious surfaces within such property will be discharged as follows:

(1) Where one or more buildings is to be constructed on the subject property in any occupancy group other than occupancy group J, drainage of storm water shall be by means of one building storm sewer or building combined sewer for each such building, which sewer shall be connected to a public street storm sewer or public street combined sewer. Such connection shall be by means of a house connection constructed in accordance with section P108.2 of this reference standard, the rules and regulations of the department and the applicable rules and regulations of the department of environmental protection, department of transportation and bureau of franchises. Provided, however, that no sewage shall be discharged into a public street storm sewer. Provided further, that the provisions of this paragraph shall apply only when

(A) the total area of impervious surfaces to be constructed on the subject property equals or exceeds twenty thousand square feet; and

(B) the commissioner of environmental protection has determined that a public street storm sewer or public street combined sewer is located within two hundred feet of any point of any boundary of such property, measured along a street, alley, right-of-way or easement; and

(C) the commissioner of environmental protection determines that it would be feasible, pursuant to subdivision (j) of this section, to discharge storm water in accordance with the provisions of this paragraph.

(2) Where paragraph one of this subdivision does not apply, drainage of storm water shall be by means of:

(A) On-site disposal of storm water in accordance with the provisions of section P110.13 of this reference standard; or

(B) Where a lot abuts a paved street which contains curbs and has been improved in accordance with the requirements of the department of transportation, drainage of storm water to the boundary of such lot abutting such street. From such boundary, such storm water may be discharged through an under-sidewalk drain or drains onto such street, provided that catch basins adequate to receive such storm water are located or installed in accordance with the requirements of this code and of the department of environmental protection. The means of drainage set forth in this subparagraph shall be used to discharge storm water from a lot only when the commissioner, with the concurrence of the commissioners of transportation and environmental protection, determines that such use is feasible; or

(C) Where a lot abuts any street, drainage of storm water by means of enclosed drainage pipes and building storm sewers or building combined sewers to the boundary of such lot abutting such street. From such boundary, all such storm water, together with all storm water falling or coming to rest on all streets and other

paved areas outside of such lot which are constructed or altered for the primary purpose of improving vehicular or pedestrian access thereto, shall be conveyed by sewers, constructed in accordance with the requirements of subdivision (h) of this section and other requirements of the department and the department of environmental protection, to a public street sewer. In no event shall sewage be discharged into a public street storm sewer. When necessary to comply with the requirements of this subparagraph, the owner of such lot shall be responsible for installation of a controlled flow storm water system in accordance with the requirements of section P110.6 of this reference standard; or

(D) In the case of any lot or development, drainage of storm water from the impervious surfaces of such lot or development by means of drainage pipes, culverts, paved swales, ditches or watercourses. Such storm water may be conveyed by such means across lot lines within a development and through under-sidewalk drains within a lot or development to a boundary of such lot or development. From such boundary, such storm water, together with all storm water falling or coming to rest on all streets and other paved areas outside of such lot or development constructed or altered in connection with the construction of one or more buildings on such lot or in such development for the primary purpose of improving vehicular or pedestrian access thereto, shall be conveyed to one of the points of disposal set forth in subdivision (d) of this section. The means of storm water disposal described in this subparagraph may be utilized only if:

(i) The owner or owners of the lot or development shall submit to the commissioner a comprehensive grading and drainage plan for such development which, in the commissioner's judgment, will satisfy the drainage requirements set forth in this section. The commissioner of environmental protection and, if such plan provides for drainage of storm water into a catch basin located in a public or private street, the commissioner of transportation shall concur in such judgment; and

(ii) When the plan described in clause (i) of this subparagraph provides for the drainage of storm water from one lot in a development across other property in such development, the owner or owners of such development shall obtain an agreement between each owner of property within such development from which or across which such storm water will be drained and the commissioner.* Such agreement shall bind each such owner and his or her heirs, successors and assigns to properly maintain the storm water drainage system. Such agreement shall be filed in the office of the county clerk in the county in which the development is located; or

(E) Any means of drainage acceptable to the commissioner, including any combination of the means specified in subparagraphs (A), (B), (C), and (D) above. Provided, however, that over-sidewalk drains shall not be permitted. Provided, further, that the commissioner shall consult with the commissioner of environmental protection or the commissioner of transportation, as appropriate, prior to approving any such combination of means or any means of drainage not specified in this paragraph.

**Language missing. So in original.*

Reference Standard 16

(d) Points of discharge for storm water from a lot or development.-Storm water drained from a lot or development pursuant to subparagraph (D) of paragraph two of subdivision (c) of this section may be discharged into:

(1) the New York harbor, or a point on a tidal creek acceptable to the commissioner of environmental protection as an adequate storm water outlet; provided that only building storm sewers and, if necessary, street storm sewers are constructed and that no sewage is discharged at such a point of disposal, and provided further that such outlets shall only be used in compliance with applicable provisions of law; or

(2) a public street storm sewer or public street combined sewer, regardless of its distance from the property, to which the commissioner of environmental protection determines that discharge of storm water is feasible, pursuant to subdivision (j) of this section, provided that no sewage shall be discharged into a street storm sewer; or

(3) an existing private street storm sewer or private street combined sewer to which the commissioner of environmental protection determines that discharge of storm water is feasible, pursuant to subdivision (j) of this section, provided that such street sewer connects with a public street sewer or, if it is a private storm sewer, discharges directly into the New York harbor, or into a point on a tidal creek acceptable to the commissioner of environmental protection as an adequate storm water outlet, in accordance with applicable provisions of law, and provided further that no sewage shall be discharged into a street storm sewer.

(e) Areaway drains.-Areaway drains may be connected to the footing or subsoil drainage system when permitted by the commissioner. Garages installed in a manner that would permit the flow of storm water from surrounding surfaces to enter the garages shall be provided with a gravity drain, or a sump and pump connected to a storm sewer, or other means of disposal as provided in this reference standard.

(f) Drains carrying clear water.-All drains carrying clear water, i.e., air conditioning drips, pump drips, cooling water, etc., may discharge into the storm water drainage system through an indirect waste connection discharging into a trapped funnel or drain.

(g) Drainage system design.-The storm water drainage system shall be designed, constructed and maintained to guard against fouling, deposit of solids and clogging and shall be provided with adequate cleanouts so arranged that the pipes may be readily cleaned.

(h) Maximum required capacity for street storm sewers or street combined sewers required by this section.-The commissioner of environmental protection may require an owner of a lot or a development who is required by this section to construct street storm sewers or street combined sewers to construct such sewers with a capacity not to exceed twenty-five percent above and beyond the capacity which the commissioner of environmental protection determines is needed for the disposal of storm water falling or coming to rest on such property together with storm water falling or coming to rest on all streets and other paved areas outside of such property which are constructed or altered in connection with the construction of a building or other substantial horizontal enlargement

on such property for the primary purpose of improving vehicular or pedestrian access thereto. The department of environmental protection reserves the right to construct catch basins connected to such sewers at the cost and expense of the city, to alleviate flooding or ponding conditions, provided that the commissioner of environmental protection determines that the capacity of such sewers shall not be exceeded.

(i) Repair of defects in catch basins and sewers required.-Any owner of property who causes any catch basin or any sewer which shall lie outside of such property to be constructed pursuant to subdivision (c) of this section shall cause all defects in such catch basin or sewer and all faults in its installation to be repaired for a period of two years after it has been installed, immediately after the commissioner of environmental protection orders such person to do so.

(j) Feasibility of discharging storm water into a street storm sewer or a street combined sewer.-The commissioner of environmental protection shall determine that the discharge of storm water into a street storm sewer or a street combined sewer pursuant to this section is feasible if he finds that:

(1) the sewer is of adequate capacity to receive all such storm water or would be adequate to receive it if the owner of property installed controlled flow storm water systems, in accordance with the requirements of section P110.6 of reference standard RS-16 of this code, to restrict the maximum anticipated storm water flow to a level set by the commissioner of environmental protection;

(2) the sewer is in adequate physical condition to receive such storm water;

(3) no physical obstacle which would make conveyance of storm water to the sewer impracticable exists between the sewer and the boundaries of the development or lot from which such storm water shall be discharged;

(4) conveyance of such storm water to the sewer is not impracticable because of the elevation of the sewer in relation to the development or lot from which such storm water shall be discharged;

(5) the sewer is located in the same drainage area as all or most of the development or lot from which such storm water shall be discharged; and

(6) no other factor reasonably related to the conveyance of such storm water from such development or lot to the sewer would make the discharge of such storm water into the sewer impracticable or undesirable as a proper means of storm water disposal.

(k) Time by which construction of the storm water drainage system required by this section shall be completed.-

The storm water drainage system for property required by this section shall be completed prior to the issuance of a certificate of occupancy by the department of buildings for, and actual occupancy of, the building or other substantial horizontal enlargement in connection with which such storm water drainage system is being constructed.

(l) Contractual obligations of the city not abrogated.-The provisions of this section shall not be construed to abrogate or contravene any contractual obligation of the city to construct storm water drainage systems or parts thereof. The requirements of subdivisions (b), (c), (d)

Reference Standard 16

and (i) of this section shall be inapplicable to an owner of property insofar as they relate to any construction work required to be performed by the city pursuant to such a contractual obligation.

(m) Remedies for non-functioning systems.-If the commissioner determines that a system of storm water disposal which has been previously approved under the provisions of this code or of previous codes is no longer providing adequate drainage of storm water from a lot or development, he or she shall order repair of such system as required by section 27-127 of this code; or if, in the judgment of the commissioner, repair of such system is not sufficient to ensure adequate drainage of storm water from such lot or development, he or she shall order that one of the methods of storm water disposal set forth in subdivisions (b) and (c) of this section shall be used to provide such drainage. The commissioner may apply to the board of standards and appeals for modification of the certificate of occupancy of any building constructed on such lot or development to require the use of such method.

**Local Law 103-1989; Local Law 7-1974*

*** Local Law 65-1996*

P110.3 Storm Water Drainage to Sanitary Sewer Prohibited.-Storm water shall not be drained into sanitary sewers intended for sewage only.

P110.4 Size of Storm Drains and Leaders.-

(a) Building storm drain.-The size of the building storm drain or any of its horizontal branches, except the branch serving a single roof drain, having a slope of 1/2 in. per ft. or less shall be based upon the maximum

projected roof or paved area to be handled according to Table RS 16-17.

(b) Storm sewers.-Where more than one building storm drain discharges into a private sewer within the property line, the sewer may be sized on a rational sewer design basis and the slope of the sewer shall be predicated on the size selected; but in no case shall the slope be less than that required to produce a velocity in the sewer of at least 3 fps.

(c) Vertical leaders.-Vertical leaders, including the branch to a single roof drain, shall be sized on the maximum projected roof area in accordance with Table RS 16-18. The equivalent diameter of square leader may be taken as the diameter of that circle which may be inscribed within the cross-sectional area of the leader. The equivalent diameter of a rectangular leader shall be taken as the number of standard size circular leaders, having a diameter equal to the short dimension of the rectangular leader that can be fitted within the rectangular leader. For example, the equivalent diameter of a 4 in. by 3 in. rectangular leader is 1-1/3 3 in. circular leaders.

(d) Roof gutters.-The size of a semicircular gutter shall be based on the maximum projected roof area according to Table RS 16-19.

(e) Combined drains and sewers.-To compute the size of a combined drain or sewer, the fixture units and the square feet of drained area shall be converted to their equivalent square footage or drainage area from Table RS 16-20 and either Table RS 16-13 or RS 16-17 shall be used to determine the pipe size required. For intermediate values, interpolation shall be used.

TABLE RS 16-17 SIZE OF HORIZONTAL STORM DRAINS

Diameter of Drain (in.)	Maximum Projected Roof Area for Various Slopes of Drains		
	1/8 in. Slope Square Feet	1/4 in. Slope Square Feet	1/2 in. Slope Square Feet
2	250	350	500
2 1/2	357	505	714
3	690	930	1,320
4	1,500	2,120	3,000
5	2,700	3,800	5,320
6	4,300	6,100	8,700
8	9,300	13,000	18,400
10	16,600	23,500	33,000
12	26,700	37,500	53,000
15	47,600	67,000	95,000

TABLE RS 16-18 SIZE OF VERTICAL LEADERS

Diameter of Leader or Conductor (in.)	gpm.	Maximum Projected Roof Area (sq. ft.)
2	22.6	433
2 1/2	39.6	779
3	66.6	1,278
4	143	2,745
5	261	4,992
6	423	8,121
8	911	17,491
10	1,652	31,718

Reference Standard 16

TABLE RS 16-19 SIZE OF ROOF GUTTERS ^a

Diameter of Gutter ^a (in.)	Maximum Projected Roof Area for Gutters of Various Slopes			
	1/16 in. Slope (sq. ft.)	1/8 in. Slope (sq. ft.)	1/4 in. Slope (sq. ft.)	1/2 in. Slope (sq. ft.)
3	144	192	272	385
4	288	409	575	815
5	500	705	1,000	1,420
6	770	1,090	1,540	2,220
7	1,150	1,560	2,220	3,120
8	1,590	2,250	3,180	4,490
10	3,600	4,080	5,780	8,000

Note-

^a Gutters other than semicircular may be used provided they have the same cross-sectional area.

P110.5 Values for Continuous Flow.-Where there is a continuous or semi-continuous discharge into the building storm drain or building storm sewer, as from a pump, ejector, air conditioning unit, or similar device, each gallon per minute of such discharge shall be computed as being equivalent to 19 sq. ft. of roof area.

P110.6 Controlled Flow Storm Water System.- In lieu of sizing the storm drainage system in accordance with section P110.4, the roof drainage may be sized on controlled flow and the storage of the storm water on the roof, provided the following conditions are met:

- (a) The water of a 10-year frequency storm is not stored on the roof for more than 24 hr.
- (b) The water depth on the roof does not exceed 3 in. during the above storm.
- (c) The roof is level and 45 degree cants are installed at all walls or parapets.
- (d) Flashing extends at least 6 in. above the roof level and scuppers are placed in the parapet wall 4 in. above the roof level.

(e) No less than two drains are installed in roof areas 10,000 sq. ft. or less; and at least four drains in roof areas over 10,000 sq. ft.

(f) Separate storm and sanitary drainage systems are installed within the building.

(g) Control is by proportional weirs and not by mechanical devices or valves.

(h) Calculations for this type of system are submitted with the required plans and piping is sized in accordance with gallon per minute ratings in Table RS 16-18.

(i) Drains on set backs may be connected to the controlled storm drainage if:

- (1) The set back is designed for storing the water, or
- (2) The square footage of drainage area of the set back is converted to gallons per minute flow on the basis of 1 gpm for each 19 sq. ft. of roof area, and the storm water pipe sizes in the controlled system are predicated on carrying the sum of the loads.
- (3) The branch from each of the roof drains that are not arranged and equipped for controlled flow conform to tables RS 16-17 and RS 16-18.

TABLE RS 16-20 "FIXTURE UNIT-DRAINAGE SQUARE FOOTAGE" EQUIVALENT

Drainage Area (sq. ft.)	Fixture Unit Equivalent
180	6
260	10
400	20
490	30
1,000	105
2,000	271
3,000	437
4,000	604
5,000	771
7,500	1,188
10,000	1,500
15,000	2,500
20,000	3,500
28,000	5,500
each additional 3 sq. ft.	1 fixture unit

Reference Standard 16

P110.7 Traps on Storm Drains and Leaders.-

(a) **Where required.**-Leaders and storm drains when connected to a combined sewer shall be trapped. No fresh air inlet will be required for building storm drains. Intake and exhaust plenum drains connected to a storm drain shall be trapped. One trap may serve more than one drain if any drain served by the trap is not more than 15 ft. from the trap.

(b) **Where not required.**-No traps shall be required for storm water drains that are connected to a building house drain or building house sewer carrying storm water exclusively.

(c) **Trap equivalent.**-A hooded catch basin located within the street line shall be the equivalent of a building or house trap for the connection to a street combined sewer.

(d) **Method of installation.**-Individual storm water traps shall be installed on the storm water drain branch serving each conductor, or a single trap shall be installed in the main storm drain just before its connection with the combined building sewer, main drain, or public sewer.

P110.8 Leaders or Storm Water Piping.-

(a) **Improper use of storm water piping.**-Leader or storm water pipes shall not be used as soil, waste, or vent pipes.

(b) **Protection of rain water conductors.**-Rain water conductors installed along alleyways, driveways, or other locations where they may be exposed to damage shall be protected by metal guards, be recessed into the wall, or be constructed of pipe.

(c) **Method of combining storm with sanitary drainage.**-The sanitary and storm-drainage system of a building shall be entirely separate except that where a combined street sewer is deemed available, the building storm drain may be connected, in the same horizontal plane through a trap and a single fitting to the combined drain or sewer at least 40 pipe diameters downstream from any soil stack.

P110.9 Roof Drain Strainers.-

(a) **General use.**-All roof areas, except those draining to hanging gutters, shall be equipped with roof drains having strainers extending at least 4 in. above the surface of the roof immediately adjacent to the roof drain. Strainers shall have an available inlet area above roof level at least 1 1/2 times the area of the conductor or leader to which the drain is connected.

(b) **Flat decks.**-Roof drain strainers for use on such decks, parking decks, and similar areas, normally serviced and maintained, may be of the flat surface type and set flush with the deck, and shall have an available inlet area at least twice the area of the conductor or

leader to which the drain is connected.

P110.10 Roof Drain Flashings Required.-

The connection between roofs and roof drains that pass through the roof and into the interior of the building shall be made watertight by the use of proper flashing material.

P110.11 Expansion Joints Required.-

Expansion joints or sleeves shall be provided where temperature variation or physical conditions may cause excessive stress or movement in the drain or piping.

P110.12 Sanitary and Storm Sewers.-Where separate systems of sanitary drainage and storm water drainage are installed in the same property, the storm and sanitary building sewers and drains may be laid side by side in the same trench.

*** P110.13 On-Site Disposal.-**

(a) Storm water, as defined in subdivision (a) of section P110.2 of this reference standard, falling on areaways 25 sq. ft. or less in area may be leached into the ground within the areaway if the ground water is at least 2 ft. below the elevation of the areaway.

(b) An owner of a lot, as defined in subdivision (a) of section P110.2 of this reference standard, may dispose of all storm water falling or coming to rest within such lot on-sight only as permitted by the provisions of subdivision (c) of section P110.2 of this reference standard.

(c) Drywells shall be the only method of on-site disposal of storm water permitted, except as provided in subdivision (a) of this section or unless an alternate method of on-site disposal is approved by the commissioner with the concurrence of the commissioner of environmental protection or the commissioner of transportation, as appropriate, pursuant to subparagraph (E) of paragraph two of subdivision (c) of section P110.2 of this reference standard. Drywells shall be constructed in accordance with the following provisions:

(1) Except as provided in paragraph two of this subdivision, the size of a drywell shall be predicated on a soil percolation test performed in accordance with the provisions of section P113.9 of this reference standard, and shall be based upon rainfall of two inches in a twenty-four-hour period on all impervious surfaces where a site is underlaid by permeable soil. Where a site is underlaid by impermeable soil, the size of a drywell shall be based upon rainfall of two inches in a twenty-four hour period over the entire site.

Reference Standard 16

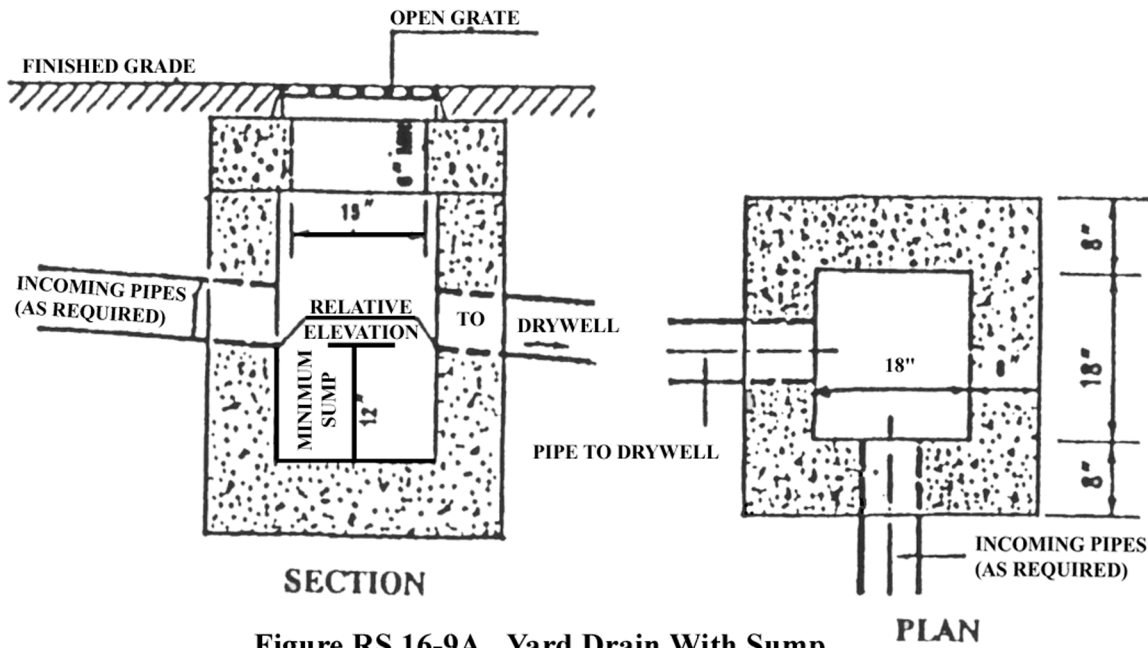

Figure RS 16-9A. Yard Drain With Sump.

(2) If a drywell is used in combination with one or more other methods of storm water disposal pursuant to subparagraph (e) of paragraph two of subdivision (c) of section P110.2 of this reference standard, the size of such drywell shall be determined by the percentage of the storm water such drywell shall dispose.

(3) The construction of drywells shall be subject to controlled inspection.

(4) Drywells shall be located at least five feet from all lot lines and ten feet from all foundations or walls existing on the date of application for a building permit or proposed under the application to construct the drywell.

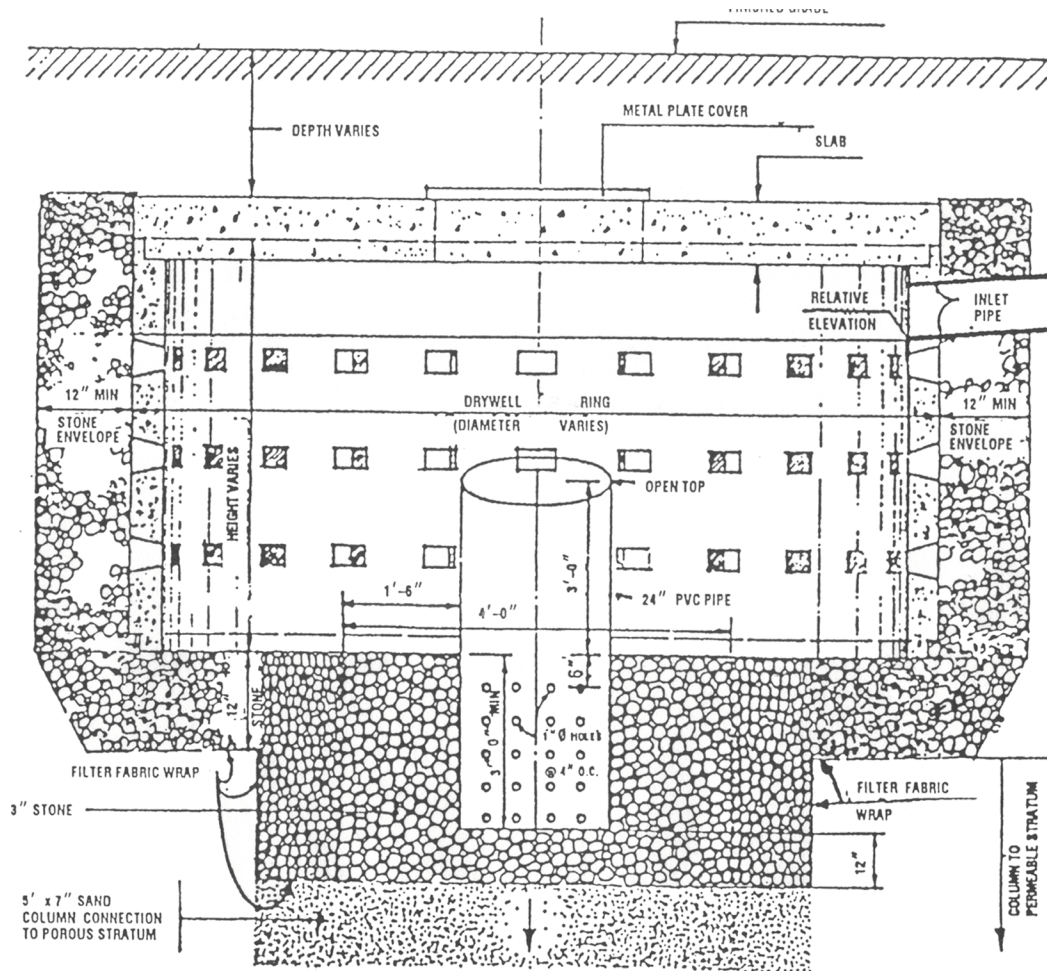

Figure RS 16-9B. Detail of Dry Well With Sand Column.

Reference Standard 16

(5) Notwithstanding the provisions of sections 27-663 and 27-664 of this code, at least one boring and one test pit shall be made at the approximate site of each contemplated drywell.

(6) The storage volume of the drywell shall be measured two feet above the level of the water table, as determined by the test pit at the site of the drywell.

(7) A grit chamber shall be included as part of all drywell systems. It shall be constructed in accordance with figure RS 16-9A.

(8) If the boring and test pit disclose that the drywell is located within or underlaid by impermeable soil, it shall be constructed in accordance with figure RS 16-9B.

(9) If the drywell is underlaid by permeable soil, it shall be constructed in accordance with figure RS 16-9B, except that the sand column to permeable soil may be omitted.

**Local Law 103-1989; Local Law 7-1974*

Section P111.0 Indirect Waste Piping

P111.1 Indirect Waste Required.-

(a) Indirect waste connections to the building drainage system shall be provided where specifically required in this reference standard and for all plumbing fixtures, appliances, and devices where the backing up of waste water or sewage from the drainage system would permit either of the following:

(1) The contamination of food, drinks, or utensils used

for the preparation or serving of foods.

(2) The contamination of surgical and medical equipment.

(b) Wastes from the following fixtures, devices, appliances, or apparatus shall discharge to the building drainage system through indirect wastes that conform to the material, trap, and drainage pipe sizing requirements of this reference standard.

(1) **FOOD HANDLING DEVICES.**-Establishments engaged in the storage, preparation, selling, servicing, processing, or otherwise handling of food shall have the waste piping from all refrigerators, ice boxes, walk-in freezers, cooling or refrigeration coils, steam tables, egg boilers, coffee urns, or similar enclosed equipment discharge indirectly into a water supplied sink or receptor. Culinary and open sinks shall be directly connected to the drainage system.

(2) **LAUNDRY WASHERS AND EXTRACTORS.**-Laundry washers, extractors, and similar equipment shall have the waste water discharge indirectly into a water supplied sink or receptor.

(3) **DRAINS AND OVERFLOWS.**-Indirect waste connections shall be provided for drains, overflows, or relief pipes from the water distribution system.

(4) **STERILIZERS.**-Stills, sterilizers, and similar appliances, devices, or apparatus that require water and waste connections and are used for sterile materials shall be indirectly connected.

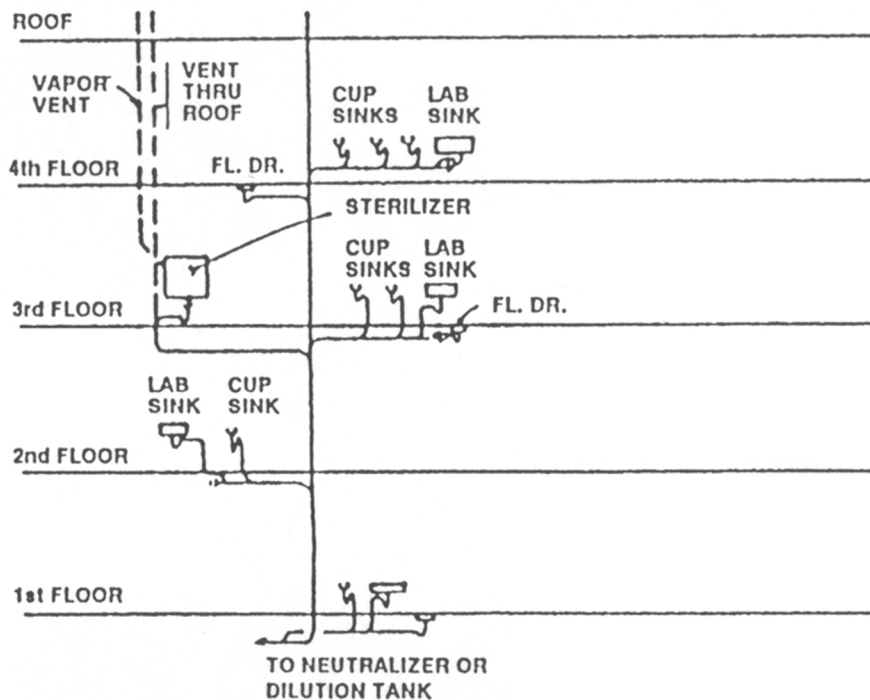

Note:

No venting if each branch to stack has 10 fix. units or less and is less than 30'-0". If branch is over 30'-0" installation shall be as shown on RS 16-11.

Figure RS 16-10. Acid Drainage for Buildings Four Stories or Less.

Reference Standard 16

(5) **DRIPS OR DRAINAGE OUTLETS.**-Appliances, devices, or apparatus not regularly classed as plumbing fixtures, but which have drips or drainage outlets, may be drained by indirect waste pipes.

(6) **WASTE DISCHARGING CLEAR WATER.**-

Expansion tanks, cooling jackets, sprinkler systems, or similar devices that waste clear water only shall discharge into the building storm or sanitary drainage system through an indirect waste.

(7) **SWIMMING POOLS.**-Pipes carrying waste water from swimming or wading pools, including pool drainage, backwash from filters, or water from scum gutter drains, shall be installed as indirect wastes. Circulation pumps may be utilized to lift waste water when the waste line is below the sewer grade.

(8) **PRESSURE TANKS, BOILERS AND RELIEF VALVES.**-The drains from pressure tanks, boilers, relief valves, and similar equipment shall be connected to the drainage system through indirect wastes.

(9) **REFRIGERATORS.**-Each indirect waste pipe from a refrigerator or equipment used for storage of food shall discharge into a receptacle through an air break and, in no instance, shall the indirect waste be trapped ahead of the air break. The maximum developed length of piping between the outlet and the air break shall be 2 ft.

(c) The air break for the indirect waste shall be provided by terminating the open end of the pipe at least 1 in. above the flood level rim of the receiving fixture or receptacle.

P111.2 Common Indirect Wastes.-The wastes from drinking fountains, bar sinks, soda fountains, and similar fixtures may be connected to a common indirect waste stack or header, provided each fixture connected thereto is properly trapped.

P111.3 Venting.-No vents need be provided for the traps of fixtures that are connected to indirect waste piping. Indirect wastes exceeding 100 ft. in developed length, except for indirect wastes from show case refrigerators, which shall not exceed 25 ft. in developed length, shall be extended through the roof or outside wall independent of vents for the regular sanitary system, and they shall terminate as required for sanitary vents.

P111.4 Sizing.-Indirect wastes shall be sized in accordance with the requirements of the direct waste system on the basis of fixture units only. Developed length shall not apply in determining pipe size.

P111.5 Receptors or Sumps.-

(a) **Installation.**-

(1) Waste receptors or sumps serving indirect waste pipes shall not be installed in any toilet room, unless installed in a separate compartment, nor in any inaccessible or unventilated space.

(2) All plumbing receptors receiving the discharge of

indirect waste pipes shall be of such shape and capacity as to prevent splashing or flooding.

(3) Standpipe receptors for automatic clothes washers shall be installed in one of the following ways:

a. The standpipe receptor shall be individually trapped and vented, the trap shall not be installed below the floor, and the standpipe shall extend not more than 30 in. nor less than 18 in. above the trap weir.

b. The standpipe receptor shall be installed in the grating of a floor drain that shall be tapped to receive the standpipe, and the floor drain size shall be predicated on either the discharge rate of the automatic clothes washer or the floor area to be drained, whichever is greater.

(b) **Strainers and baskets.** Every indirect waste receptor shall be equipped with a removable basket or a beehive strainer not less than 4 in. in height. Floor drains receiving an indirect waste discharge need not have dome strainers.

(c) **Domestic or culinary fixtures prohibited as receptors.** No plumbing fixture that is used for domestic or culinary purposes shall be used to receive the discharge of an indirect waste pipe, except that in a dwelling a kitchen sink may be used as the receptor for a dishwasher, and a laundry tray may be used as the receptor for a clothes washing machine.

P111.6 Condensers and Sumps.-No steam pipe shall connect to any part of a drainage or plumbing system, nor shall any water above 150 degrees F be discharged into any part of the drainage system, except that 180 degrees water may be discharged as permitted herein from a commercial dishwasher or laundry. Such pipes, except from the dishwasher, shall be connected by discharging into an indirect waste receptor connected to the drainage system.

Section P112.0 Special and Miscellaneous Waste Piping

P112.1 Industrial Wastes.-Industrial wastes from abattoirs, chemical plants, metal platers, dye works, and similar wastes may not be discharged to a sewer system without an industrial waste permit of the department of public works, except as hereinafter provided.

P112.2 Chemical Wastes.-

(a) No corrosive liquids, acids, strong alkalis, or other chemicals that might destroy or damage the drain, soil, waste, or vent pipes, or that might create noxious or dangerous fumes, shall be discharged into the regular drainage systems until brought within permitted concentrations by treatment.

(b) Such chemicals shall discharge through an independent sanitary drainage system to a dilution or neutralizing device as described in section P105.0 or through some other means of disposal designed by an architect or engineer, subject to the approval of the commissioner and of any other agency or agencies

Reference Standard 16

having jurisdiction.

(c) Chemical waste and vent piping shall be of materials resistant to the corrosive action of chemical fumes in accordance with section P102.4.

(d) The size of the vent and drainage piping shall meet the requirements for sanitary vent and drainage systems in sections P108.0 and P109.0.

(e) All traps in an acid waste system shall have a deep seal.

(f) The acid drainage system shall consist of a waste and a vent stack. In a building where acid drainage systems are provided to serve fixtures, drains, and/or equipment on four floors or less and have no horizontal branch from the waste stack exceeding 30 ft. developed length to the farthest fixture, the waste stack can serve as a wet vent and no branch venting shall be required. See Figure RS 16-10 for typical installation.

(g) Acid dilution or neutralization sumps may be located directly adjacent to, or beneath, each acid sink or fixture. The discharge from each individual acid sump shall connect to the sanitary drainage system and the vent shall be treated in the same manner as a sanitary vent.

(h) Where a common acid neutralization sump for several fixtures or stacks is used, it shall be located at

the lowest story above the house drain. A separate acid dilution sump may be used for fixtures on the first floor and below, and the neutralized effluent shall be lifted from the acid dilution sump to the gravity drainage system by pumping. The drain line at the inlet to dilution sump shall be provided with a relief vent at least 2 in. in diameter or 1/2 the diameter of inlet pipe, whichever is greater. The vent shall terminate in the outside air above the roof or connect to an acid system vent stack or stack vent.

(i) Each drainage pipe that extends more than 30 ft. from the stack or has more than ten fixture units discharging into it shall be provided with a vent connection from the vent stack or stack vent to a connection in the drain line installed between the last two fixtures on the drain line and each 30 ft. increment. Also, a relief vent shall be installed in the horizontal branch waste within 4 ft. of the stack. See Figure RS 16-11 for typical installation.

(j) Fixtures such as floor drains, receptors receiving the indirect waste from sterilizers, stills, and drains from other laboratory equipment within the laboratory area may be connected to the acid drainage system, if the fixtures, excluding floor drains, are provided with individual vents, and all of the piping connecting these fixtures of acid resistant material, or when permitted by

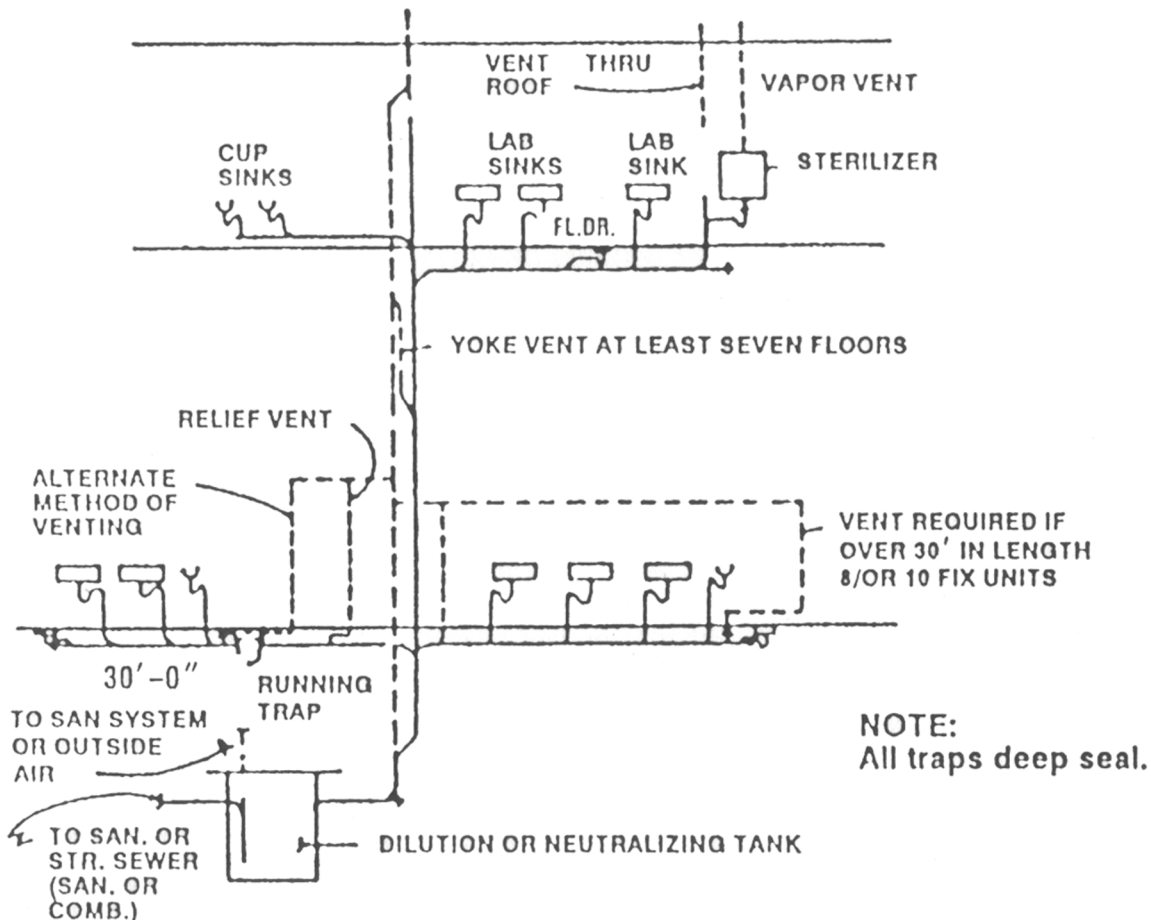

Figure RS 16-11. Acid Drainage for Buildings Over Four Stories.

Reference Standard 16

the commissioner, of cast iron.

(k) Materials shall be in accord with section P102.4(b)(5) and P102.4(c)(3).

P112.3 Flammable Solvents or Oil Wastes.-

Flammable solvents or oil wastes shall be disposed of in accordance with the requirements of section P105.0 or such other method as may be permitted by the department of public works, so that no appreciable amount of flammable or combustible material is discharged to the public sewer in such quantities as to cause an explosive condition. See Figure RS 16-9 for typical installation.

P112.4 Radioactive Wastes.-

Radioactive wastes shall be treated and disposed of by a method designed by an architect or engineer, subject to the approval of the commissioner and of any other agency or agencies having jurisdiction.

***Section P113.0 Individual Sewage Systems**

***Local Law 85-1973*

*****P113.1 Information Required.-**An applicant desiring to construct an individual on site private sewage disposal system shall file a statement certified by a registered architect or licensed professional engineer that there is no available sewer to which the property in question may connect and the distance to the nearest

public sewer. In addition, such construction shall be subject to a site and subsoil evaluation to be performed under the supervision of an employee of the department.

****Local Law 65-1996*

P113.2 Individual Sewage Disposal Systems.-

Where public sewers are deemed not available, the method of sewage disposal shall be designed by an architect or engineer, subject to the approval of the commissioner.

P113.3 Individual Sewage Disposal System (One-and Two-Family Dwellings).-

Where public sewers are deemed not available and a temporary private pumping station or community disposal system is not installed, an individual private sewage disposal system shall be designed by a licensed professional engineer or registered architect and installed in accordance with the requirements of this reference standard and shall be subject to controlled inspection.

P113.4 Housing Development Sewage Disposal Systems.-

When housing developments consisting of more than 15 one-family dwellings or a multiple dwelling of 15 or more dwelling units, are to be built and public sewers are deemed not available, a communal sewage disposal system with street sewers shall be installed in accordance with the drainage plan of the department of water resources.

****TABLE RS 16-21 MINIMUM DISTANCES BETWEEN SEWAGE SYSTEM COMPONENTS AND BETWEEN COMPONENTS AND INCUMBRANCES**

System components	Building		Disposal Field	Seepage Pits	Drywell	Water Service Line
	Foundation wall	Property line				
Septic tank	5 ft.	—	5 ft.	5 ft.	—	—
Disposal field	10 ft.	5 ft.	20 ft.	20 ft.	20 ft.	10 ft.
Seepage pits	15 ft.	10 ft.	20 ft.	20 ft.	20 ft.	10 ft.
Drywells	10 ft.	5 ft.	20 ft.	20 ft.	—	—

Note-

The seepage pits and drywells may be located contiguous with street line.

***Local Law 103-1989; Local Law 85-1973*

P113.5 General Requirements.-

- (a) The sewage disposal system shall consist of all necessary piping and a septic tank or tanks that discharge into a disposal field or seepage unit, as may be required. Septic tanks shall not discharge into open streams.
- (b) Storm water or ground water shall not be discharged into a septic tank or into the disposal system used to disperse the effluent from the septic tank.
- (c) The use of cesspools is prohibited.
- (d) Slope from seepage unit or distribution pipe invert to lower grades shall not exceed 7.5 percent.
- (e) Backfill surrounding the seepage unit stone shall be clean, coarse sand as specified.
- (f) Sheathing for seepage unit shall be removed after backfilling.
- (g) All manholes in paved areas shall have a cast iron watertight frame and cover flush with the finished paved surface.
- (h) Slope of lines to septic tank, seepage unit and distributing box shall be not less than 1/4 in. per ft. and shall be shown on the drawings. All piping to these components shall be extra heavy cast iron pipe, not less than 4 in. inside diameter.

- (i) The entire system shall be located in front of the building unless it is not feasible to do so. If placed in a location other than the front, dry piping with trap properly plugged, shall be carried from the house plumbing stack through the front foundation wall to preclude the need for rearranging plumbing when sewers become available; clear access not less than nine feet wide, shall be provided to the disposal system for servicing.
- (j) Sand used in all absorption systems or in fill operations as a medium for subsurface disposal of sewage effluent shall be clean, coarse sand, all passing a 1/4 in. mesh screen, conforming to ASTM specifications C33-1967.
- (k) Stone used in all systems shall be washed and graded, hard durable fragments of granite, trap or other approved rock free from thin or long pieces, screenings, dust, fine stone and foreign substances. The stone shall be well graded between the limits specified.

P113.6 Location.-

The minimum permissible distance between the various components of the sewage system and between the components and various

Reference Standard 16

encumbrances are given in Table RS 16-21. All components shall be located within the property line of the premises for which the system is installed.

P113.7 Septic Tanks.-(a) **Construction.**-Septic tanks shall be constructed of material not subject to excessive corrosion or decay and shall be made watertight. Manhole covers and roof shall be designed for a live load of at least 150 psf. Concrete covers when used, shall be reinforced and at least 4 in. thick. Metal septic tanks shall conform to United States Commercial Standard 177-62.

***(b) Manholes.-**

(1) The septic tank shall have one manhole situated over the inlet and one over the outlet of the tank. Manholes shall be at least 20 in. square or 24 in. in diameter. The top of the manhole cover shall extend to within 12 in. of final grade to provide easy access for inspection and cleaning. If the septic tank is placed deep in the ground, a chimney or riser shall be provided to raise the manhole cover to the required distance below grade. No person other than a licensed master plumber or a person engaged in sewer services shall remove or open the manhole cover of any septic tank unless otherwise authorized during an emergency by an officer or employee of a city agency.

(2) For purposes of this subdivision, "person engaged in sewer services" shall be defined as one who renders sewer services, including but not limited to installing, altering, repairing, cleaning and pumping sewers, septic

tanks and cesspools, as a part of one's regular business or employment.

**Local Law 21-1981*

(c) Capacity.-

(1) Minimum rated capacity of septic tanks shall be in accordance with Table RS 16-22, and shall be predicated upon the 24-hr. sewage flow under normal conditions, plus an allowance of approximately 20 percent for sludge accumulation.

(2) In a tank of more than one compartment, the inlet compartment shall have a capacity of at least two-thirds of the minimum required tank capacity prescribed in Table RS 16-22.

(d) Design.-The concrete tank shall have a water surface at the flow line that is rectangular in plan with the length at least twice the width but no more than three times the width (Figure 16-12A). For steel tanks use 5 ft. diameter (Figure 16-12B).

**** Figure RS 16-12A Typical Concrete Septic Tank**

***Local Law 85-1973*

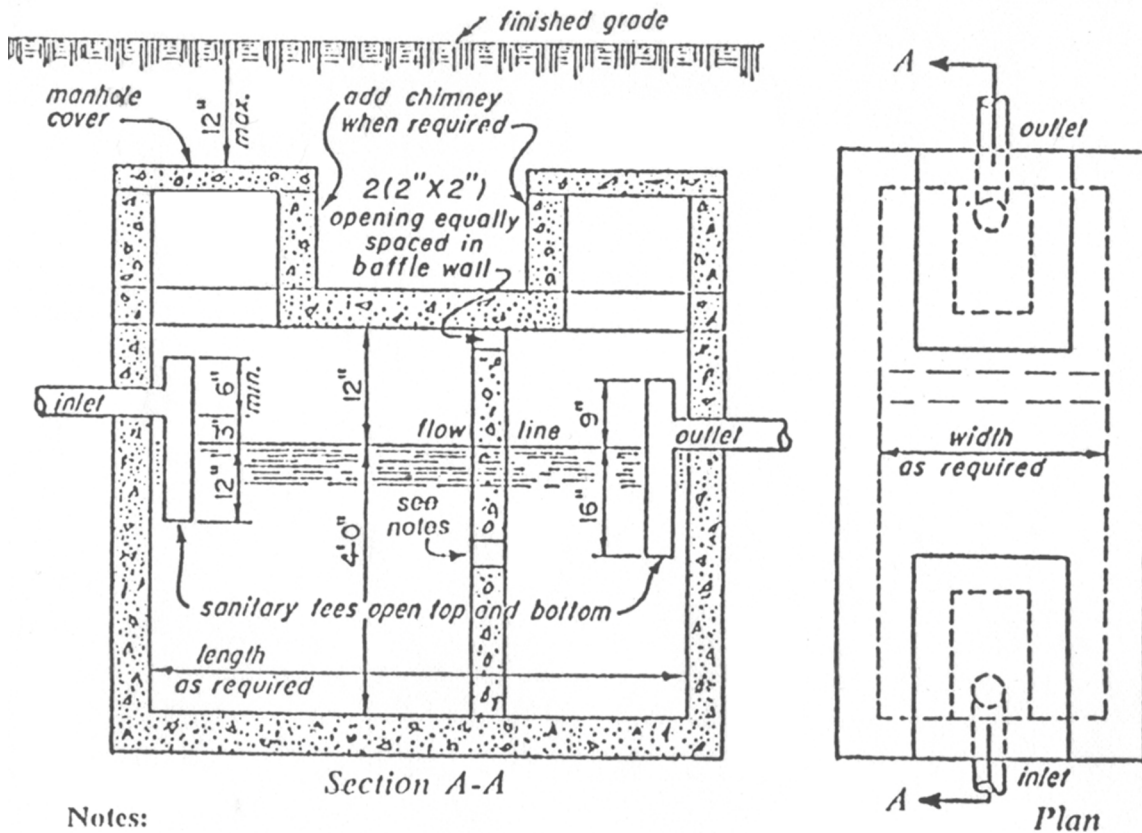

Notes:

1. Interior baffle wall required in all tanks over 9 feet in length.
2. Slot 4" wide by 16" long or two 6" diameter holes at 18" centers.

Reference Standard 16

****TABLE RS 16-22 MINIMUM CAPACITY OF SEPTIC TANKS**

Type of Dwelling	Number of Bedrooms	Minimum Capacity of Tank to Flow Line, Including Sludge Accumulation (Gallons)
1 Family	2	750
1 Family	3	900
1 Family	4	1,000
1 Family	5	1,250
1 Family	6	1,500
2 Family	4	1,500
2 Family	5	1,750
2 Family	6	2,000
2 Family	7	2,250
2 Family	8	2,500

Note-

If there is an expansion attic: (a) without bathroom add one additional bedroom, (b) add two additional bedrooms, if bathroom is included. Rate: 250 gallons for each additional bedroom.

****Local Law 85-1973**

P113.8 Distribution Box.-A distribution box shall precede all subsurface disposal fields. The distribution box is the chamber into which the septic effluent discharges and from which the sewage enters the subsurface disposal field lines. The box shall be of concrete or steel. If steel, it shall be 12-gage minimum, bituminous-coated in accordance with Commercial Standard 177 of 1962. Floor area of box should be as small as practical in order to provide a maximum head of sewage for equal distribution to all outlet lines. Top of box shall be at least 9 inches above the invert of the

outlet lines. A baffle at the inlet shall be provided to prevent "short circuiting" of flow. The walls of the box shall be high enough so that the cover will be within 12-inches of the finished grade. All outlet inverts shall be set one inch below the inlet invert. Lines from distribution box to disposal field shall be not less than 4 inches inside diameter and shall be laid with tight joints on a uniform slope not less than 1/8 inch per foot.

*****P113.9 Soil Percolation Tests.** -Soil percolation tests shall be performed at the site of a proposed individual on site private sewage disposal system installation to determine the suitability of the soil and site. Such test shall be performed under the supervision of an employee of the department as well as subject to controlled inspection. The result of the percolation tests shall be filed on forms provided by the department, stating the suitability of the site and the capacity of the subsoil for the proposed use.

*****Local Law 65-1996**

P113.10 Seepage Units.-(a) **Capacity.**-The liquid capacity (volume below inlet line) of seepage units shall be at least twice that of the septic tank, as prescribed in Table RS 16-22. In addition, sufficient wall area shall be provided to permit the liquid wastes to leach into the soil without overflowing. Effective absorption area, i.e., the wall area at the outer circumference of the annular stone for any type of dwelling shall be computed in accordance with the Table RS 16-23A or Table RS 16-23B.

**** Figure RS 16-12B Typical Metal Septic Tank**

****Local Law 85-1973**

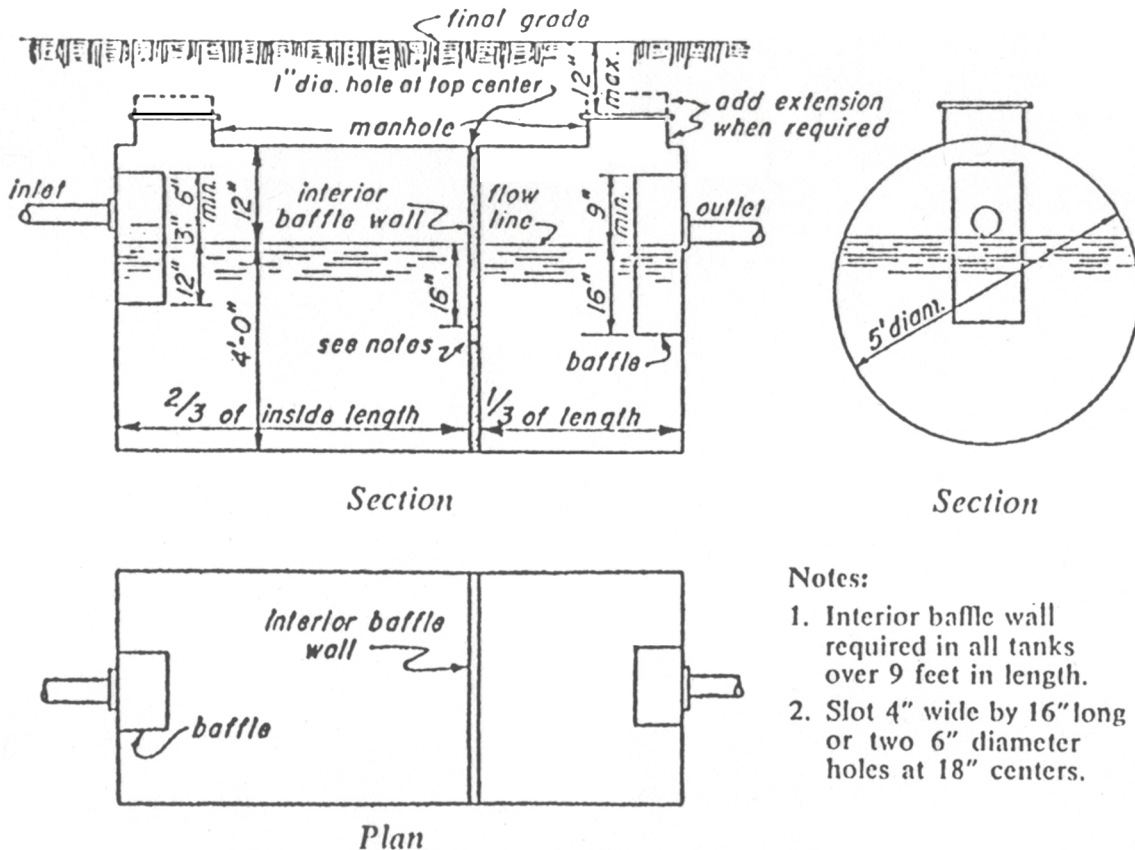

- Notes:**
1. Interior baffle wall required in all tanks over 9 feet in length.
 2. Slot 4" wide by 16" long or two 6" diameter holes at 18" centers.

Reference Standard 16

****TABLE RS 16-23A DESIGN DATA FOR ABSORPTIVE CAPACITY OF DISPOSAL FIELD AND SEEPAGE PITS^a**

Effluent Allowance Rate of Seepage Unit in gallons per square foot of effective absorptive area per day		
Percolation Rate		
Percolation Test rate in minutes for water to fall 1 inch	Disposal Field Trenches (bottom of trenches)	Seepage Pits (wall area)
2 or less	3.2	4.3
5	2.4	3.2
10	1.7	2.3
30	0.8	1.1
60 (not recommended)	0.4	0.6
Over 60 (not suitable)	Obtain special approval of the commissioner. (Use special design by an architect or engineer, subject to the approval of the commissioner.)	

^a For one- or two-family dwellings table RS 16-23B shall be used.

Notes-

Volume of sewage to be disposed of should be equal to the 24 hr. sewage flow.

No portion of the field shall be installed under any pavement or any area where there will be vehicular traffic or parking.

****Local Law 85-1973**

****TABLE RS 16-23B DESIGN DATA FOR ABSORPTIVE CAPACITY OF DISPOSAL FIELD AND SEEPAGE PITS**

Type of Dwelling	Number of Bedrooms	Minimum Capacity of Field and/or of Pit to Flow Line
1 Family.....	2	750
1 Family.....	3	900
1 Family.....	4	1,000
1 Family.....	5	1,250
1 Family.....	6	1,500
2 Family.....	4	1,500
2 Family.....	5	1,750
2 Family.....	6	2,000
2 Family.....	7	2,250
2 Family.....	8	2,500

Notes-

Add 250 gallons for each additional bedroom. To compute peripheral wall area in sq. ft. for gravel envelope of pits, divide above minimum capacity by 4.3.

To compute area required for disposal field in sq. ft. divide above minimum required capacity by 1.15.

****Local Law 85-1973**

Ref

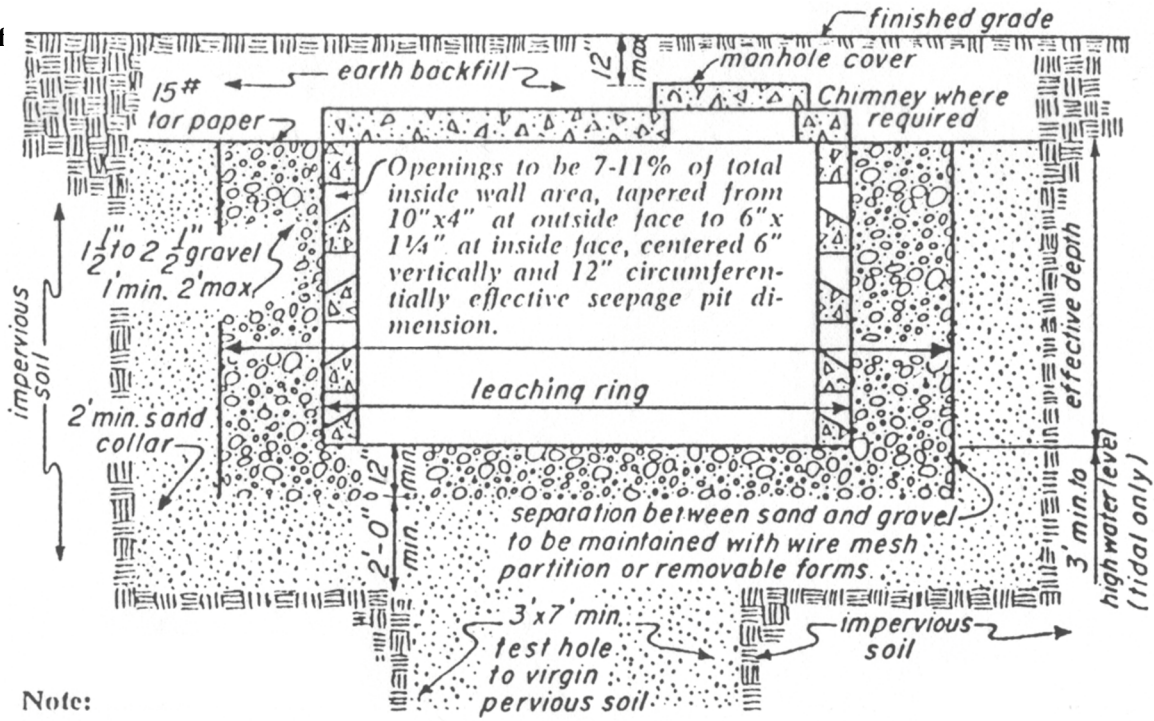

Note:

Sand collar must make full contact with test hole.

(b) **Construction.**-The seepage unit shall be structurally sound. The piping from the septic tank to the unit shall have tight joints. The general construction arrangement shall be in accordance with Figure RS 16-13A or RS 16-13B.

** Figure RS 16-13A Absorption Type System

**Local Law 85-1973

** Figure RS 16-13B Absorption Type

**Local Law 85-1973

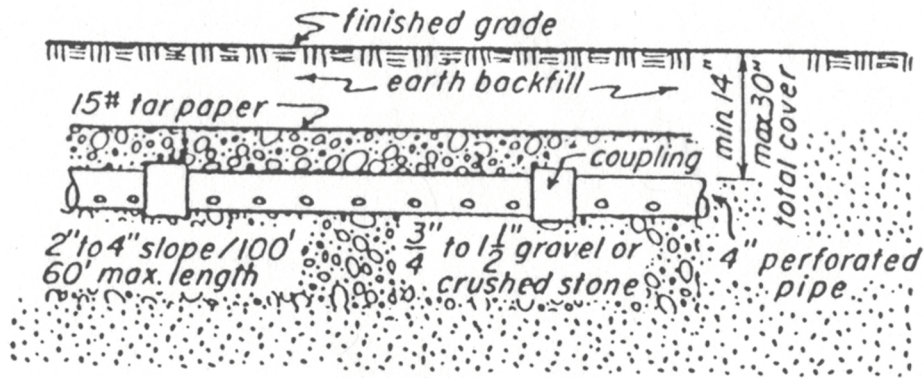

Disposal Field Details

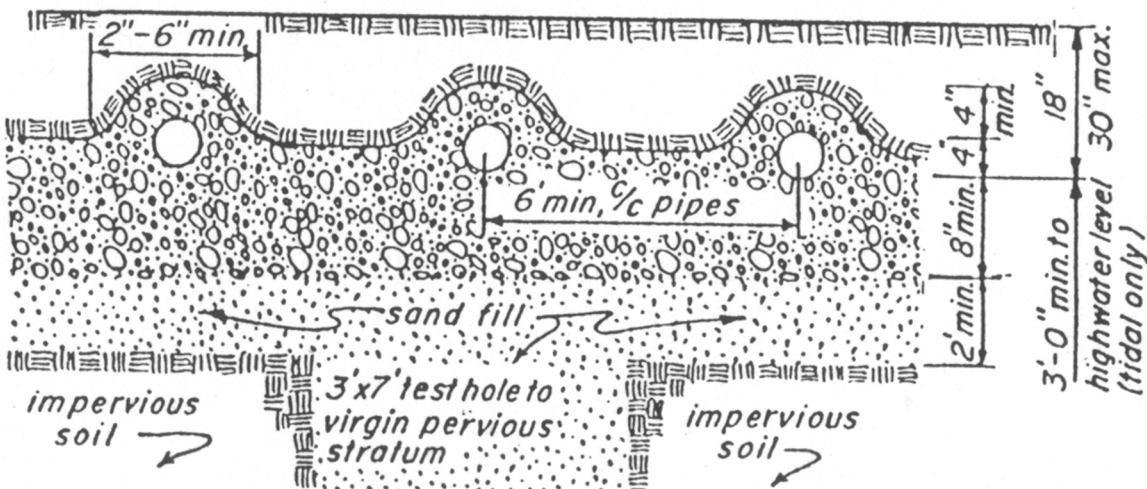

Reference Standard 16

(c) No disposal system shall extend into the water table thereby causing a direct discharge of effluent into the said ground water table. However, in tidal areas, the base of the seepage units or distribution pipes in a field shall be at least 3 feet above the highest water level encountered in the excavated test pit.

P113.11 Subsurface Disposal Field.-

(a) **General.**-Each disposal field shall have at least two outlet distribution lines from the distribution box. The field shall be in an open area, at least 20 ft. from the outer surface of any tree trunk. No portion of the field shall be installed under any pavement or any area where there will be vehicular traffic or parking.

(b) **Construction.**-An absorption-type disposal field, Figure RS 16-13B, may be used in locations wherever an impervious soil stratum overlays a pervious stratum and a seepage unit is not feasible or desired. Septic tank effluent is conducted to a distribution box and thence through the system of perforated pipes for dispersal over the bed of crushed stone or gravel and sand of the required area. This bed of pervious material, overlaying the natural unsatisfactory impervious soil, together with the column of sand (test hole) located within the area of the field, previously prepared and tested, serves as the media through which the septic tank effluent finds its way to the underlying natural pervious soil for eventual subsurface disposal. The allowable 24-hour rate of septic tank effluent application per square foot of field surface shall be at the maximum rate of 1.15 gallons. Lines leading from the distribution box to the head end

of the disposal field shall be extra heavy cast iron pipe not less than 4 in. inside diameter, having tight joints. All distribution lines in the disposal field shall be approved perforated pipe at least 4 in. inside diameter. These lines shall have a uniform slope, 2 in. to 4 in. per 100 ft. with a minimum spacing of 6 ft. on centers. All distribution lines shall be of equal length not over 60 ft. long to provide uniform distribution of the effluent and shall have a minimum cover of 14 in. on the pipe. Wherever it may be necessary to construct a large percentage of the field lines with cover in excess of 30 in., other designs using seepage units if possible should be considered.

(c) **Filter material.**-The lines shall be surrounded by crushed stone or gravel ranging in size from 3/4 in. to 1 1/2 in. from a level at least 8 in. below the bottom of the pipe to a level at least 4 in. above the top of the pipe. The upper surface of the stone shall be covered with a layer of impervious tar paper, minimum weight 15 pounds, before placing the earth backfill, in order to prevent soil from penetrating into the filter material and subsequently into the pipes.

(d) **Distance requirements.**-Disposal fields shall be installed in accordance with the requirements of Table RS 16-24.

P113.12 Maintenance.-A chart, showing the location of the septic tank and the field system for a building, shall be kept at a suitable location within the building. This chart shall also contain brief inspection and maintenance instructions for the septic tank.

****TABLE RS 16-24 LIMITING DIMENSIONS OF DISPOSAL FIELD COMPONENTS**

Component	Limit
Individual lines, maximum length	60 ft.
Individual lines, lengths.....	All of equal length
Field distribution pipe, minimum diameter.....	4 in.
Field distribution pipe, maximum slope	4 in. per 100 ft. length
Field distribution pipe joints	Tight (no spaces) as required by type of pipe
Trench or bed bottom, minimum depth	18 in.
Trench or bed bottom, average depth	Not more than 30 in.
Trench or bed bottom, minimum above ground water ...	2 ft.
Trench bottom, minimum width (percolation rate of 2 minutes or less)	18 in.
Trench bottom, minimum width (percolation rate of 5 to 10 minutes)	24 in.
Trench bottom, maximum width for other more impervious soils	30 in.
Trench or bed, minimum separation between	3 times trench width but not less than 6 ft.

**Local Law 85-1973

Section P114.0 Hospital and Institutional Plumbing

P114.1 General.-Hospital and institutional plumbing systems shall comply with all applicable plumbing requirements, except as specifically modified

in this section.

P114.2 Definitions for Special Hospital Fixtures and Equipment.-

Reference Standard 16

ASPIRATOR.-A fitting or device that is supplied with water or other fluid under positive pressure. The water or other fluid passes through an integral orifice, or constriction, causing a vacuum. Aspirators are often referred to as "suction" apparatus, and are similar in operation to an ejector fitting.

AUTOPSY TABLE.-A fixture or table used for the post-mortem examination of a body. (See Section P107.0 for method of connecting water supply.)

BEDPAN HOPPER (CLINIC SINK).-A fixture used to flush the contents of bedpans and meet the design requirements of Section P114.3(a).

BEDPAN STEAMER.-A fixture used for sanitizing bedpans or urinal bottles by direct application of steam.

BEDPAN WASHER.-A fixture designed to wash bedpans and to flush the contents into the sanitary drainage system. It may also be used for sanitizing bedpans and urinals with steam or hot water.

BEDPAN WASHER DEVICE.-A device used for cleansing bedpans. It is supplied with hot and/or cold water, and is located adjacent to a water closet or clinic sink or installed in the discharge piping of the flush valve.

BEDPAN WASHER VENT.-A local vent that is a vertical pipe to which connections are made from the fixture side of traps and through which vapor and/or foul air may be removed from the bedpan washer.

CLINIC SINK.-See "Bedpan Hopper."

STERILIZER, BOILING TYPE.-A fixture (nonpressure vessel) used for boiling instruments, utensils, and/or other equipment for the purpose of disinfection. Some devices are portable, others are connected to the plumbing system.

STERILIZER, PRESSURE (AUTOCLAVE).-A fixture (pressure vessel) designed to use steam under pressure for sterilizing.

STERILIZER, PRESSURE (INSTRUMENT WASHER-STERILIZER TYPE).-A fixture (pressure vessel) designed to both wash and sterilize instruments during the operating cycle of the fixture.

STERILIZER VENT.-A separate pipe or stack, indirectly connected to the building drainage system at the lower terminal. The pipe or stack receives the vapors from nonpressure sterilizers or the exhaust vapors from pressure sterilizers and conducts the vapors directly to the outer air. (Sometimes called a vapor, a steam, an atmosphere or an exhaust vent.)

STERILIZER, WATER.-A fixture (pressure vessel) designed for sterilizing water and storing this sterile water.

STILL.-A device used for distilling liquids.

P114.3 Requirements for Special Hospital Fixtures and Equipment.-Bedpan hoppers (clinic sinks), bedpan washers, and similar fixtures and

equipment shall be provided for disposal of bedpan contents and cleansing and disinfecting bedpans. All such fixtures and equipment shall be subject to the following requirements:

(a) Bedpan hoppers (clinic sinks).-Such fixtures shall have an integral trap in which the upper portion of a visible trap seal provides a water surface. The fixture shall be designed so as to permit complete removal of the contents by siphonic and/or blow-out action, and to reseal the trap in a single flushing operation. A flushing rim shall provide water to cleanse the interior surface. The fixtures shall have flushing and cleansing characteristics similar to a water closet.

(b) Prohibited use of clinic sinks and service sinks.-A clinic sink shall not be used as a janitor's service sink. A janitor's service sink shall not be used for the disposal of urine, fecal matter, or other human wastes.

(c) Special requirement for ice manufacture and storage.-No machines for manufacturing ice, or any device for handling or storing ice, shall be located in a room containing a bedpan hopper, clinic sink, bedpan washer, or similar fixture. Machines for manufacturing ice, or devices for handling or storing ice intended for either human consumption or packs, shall be located in a clean utility room, a floor pantry, a diet kitchen, or in other similar locations.

(d) Sterilizers.-

(1) DESCALING PROHIBITED.-The interior of water sterilizers, stills, or similar equipment shall not be descaled or otherwise treated by acid or other chemical solutions while the equipment is connected to the water and/or drainage system.

(2) STANDARD.-New pressure sterilizers and pressure type instrument washer-sterilizers hereafter installed shall conform to ASME boiler and pressure vessel code, 1962, section VIII and shall bear a data plate clearly visible at all times indicating conformity to such standards.

(3) STERILIZER PIPING.-All sterilizer piping and/or devices necessary for the operation of sterilizers shall be accessible for inspection and maintenance.

a. **Steam supply.**-Steam supplies to sterilizers, including those connected by pipes from overhead mains or branches, shall be drained to prevent any excess moisture from reaching the sterilizer. The condensate drainage from the steam supply shall be discharged by gravity.

b. **Condenser.**-Pressure sterilizers shall be equipped with a means for condensing exhaust steam vapors.

c. **Gas fired equipment.**-Gas fired equipment or apparatus requiring either water or drainage connections, or both, shall comply with the requirements of this reference standard and the applicable provisions of the building code.

P114.4 Plumbing in Mental Hospitals.-Special consideration shall be given to the design and installation of plumbing fixtures in mental hospitals. No

Reference Standard 16

pipes or traps shall be exposed and all fixtures shall be securely bolted through walls.

P114.5 Number of Plumbing Fixtures.-The minimum number of fixtures for hospital and institutional occupancy shall be in accordance with Table RS 16-25, Fixtures for Hospitals and Institutions.

P114.6 Drainage and Venting.-

(a) Ice storage chest drains.-Each drain serving an ice chest or box shall discharge into an indirect waste receptor. Each drain shall discharge through an air break above the receptor. The end of the drain shall be covered with a removable screen of not* at least 10 mesh per in. or with a flap valve.

(b) Bedpan washers and clinic sinks.-Bedpan washers and clinic sinks shall be connected to the sanitary drainage system and vented in accordance with the requirements for water closets, except that bedpan washers with vapor vent connections shall require additional vapor vents.

**As enacted but probably "net" is intended.*

P114.7 Sterilizer Wastes.-

(a) Indirect wastes required.-Each sterilizer shall be provided with an individual and separate indirect waste, and with an air break having a diameter at least twice that of the waste tailpiece. The upper rim of the receptor, funnel, or basket type fitting shall be at least 2 in. below the vessel or the piping, whichever is lower. Except as provided in (b) below, a "P" trap shall be installed on the discharge side of, and immediately below, the waste connection serving each sterilizer.

(b) Floor drain required.-In all rooms containing the recessed or concealed portions of sterilizers, the entire floor area shall be drained and at least one floor drain shall be installed. The floor drain waste and trap shall have a minimum diameter of 3 in. It shall receive the drainage from at least one sterilizer to assure maintenance of the floor drain trap seal. No individual sterilizer waste trap shall be required on this type of installation.

TABLE RS 16-25 MINIMUM NUMBER OF FIXTURES FOR HOSPITALS AND INSTITUTIONS

Type of Building Occupancy	Type of Fixtures					
	Water Closets	Urinals	Lavatories	Bathtubs or Showers	Drinking Fountains	Other Fixtures
Institutional—other than hospitals or penal institutions (on each occupied story)	1 for ea. 25 men 1 for ea. 20 women	1 for each 50 men	1 for each 20 persons	1 for each 10 persons	1 for each 50 persons	In accordance with the hospital code of the city of New York
Hospitals – general	See table RS 16-5					
Hospital – employees	See Public Facilities					
Institutional – prisoners	1 in each cell		1 in each cell	1 in each cell	1 on each cell block floor	1 slop sink per floor
	1 in each exercise room	1 in each exercise room	1 in each exercise room		1 in each exercise area	
Institutional – employees and public Facilities –	See Table RS 16-5					
Nursing homes –	in accordance with the nursing home code of the city of New York.					

(c) Bedpan steamers, additional trap required.-A trap with a minimum seal of 3 in. shall be provided in a bedpan steam drain located between the fixture and the indirect waste connection.

(d) Pressure Sterilizer.-Except when an exhaust condenser is used, a pressure sterilizer chamber drain may be connected to the exhaust drip tube before terminating at the indirect waste connection. If a vapor trap is used, it shall be designed and installed to prevent moisture being aspirated into the sterilizer chamber. The jacket steam condensate return, if not connected to a gravity steam condensate return, shall be separately

and indirectly wasted. If necessary to cool a high temperature discharge, a cooling receiver, trapped on its discharge side, may serve as the fixture trap.

(e) Exhaust condensers.-Drain from exhaust condensers shall be installed with an indirect waste as prescribed in this code. If such condensers are used on pressure sterilizers, the chamber drain shall have a separate indirect waste connection.

(f) Water sterilizer.-All water sterilizer drains, including tank, valve, condenser, filter and cooling, shall be installed with indirect waste.

(g) Pressure type instrument washer-sterilizer.-The

Reference Standard 16

pressure type instrument washer-sterilizer chamber drain and overflow may be interconnected. They may also be interconnected with the condenser. The indirect waste shall comply with the provisions of this reference standard.

P114.8 Vapor Vents.-

(a) Vent material.-Material for sterilizer, vapor, and exhaust vents shall be as required by Section P102.4.

(b) Vent connections prohibited.-Connections between vapor vents serving bedpan washers, sterilizing apparatus, and/or normal sanitary systems, are prohibited. Only one type of apparatus shall be served by a given type vent.

(c) Bedpan Vents and stacks.-

(1) BEDPAN WASHERS.-Bedpan washers shall be vented to the outer atmosphere above the roof by means of bedpan vents. The vent for a bedpan washer shall be at least a 2 in. diameter pipe. A bedpan vent serving a single bedpan washer may drain to the fixture served.

(2) MULTIPLE INSTALLATIONS.-Where bedpan washers are located above each other on more than one

floor, a bedpan vent stack may be installed to receive the bedpan vent on the various floors. The connections between a bedpan washer vent and a bedpan vent stack shall be made by using tee or tee-type sanitary pattern drainage fittings, installed in an upright position. See Table RS 16-26 for vent sizing.

(3) TRAP REQUIRED.-The bottom of the bedpan vent stack, except when serving only one bedpan washer, shall be drained by means of a trapped connection discharging indirectly into the plumbing sanitary drainage system. The trap and waste shall be at least 2 in. in size.

(4) TRAP SEAL MAINTENANCE.-A water supply of at least 1/4 in. tubing shall be taken from the flush supply of each bedpan washer on the discharge or fixture side of the vacuum breaker, trapped to form at least a 3 in. seal, and connected to the local vent on each floor. The water supply shall be so installed as to provide a supply of water to the local vent stack for cleansing and drain trap seal maintenance each time a bedpan washer is flushed.

**TABLE RS 16-26
STACK SIZES FOR BEDPAN STEAMERS AND BOILING TYPE
STERILIZERS AND NUMBER OF CONNECTIONS PERMITTED**

Stack Size (in.)	No. of Connections Permitted	
	Connection Size (in.)	
	1 1/2	2
1 1/2	1	or 0
2	2	or 1
2	1	and 1
3	4	or 2
3	2	and 2
4	8	or 4
4	4	and 4

(d) Pressure sterilizer vent and stacks.-

(1) CONNECTIONS.-In multiple installations of pressure and nonpressure sterilizers, vent connections to the sterilizer (vapor) vent stack shall be made by means of inverted type fittings.

(2) DRAINAGE.-The connection between sterilizer vent and/or exhaust openings and the sterilizer vent stack shall be designed and installed to drain to the funnel or basket-type waste fitting. In multiple installations, the sterilizer vent stack shall be drained separately to the lowest sterilizer funnel or basket-type waste fitting or receptor.

P114.9 Sizing of Sterilizer Vent Stack.-

(a) Bedpan steamers.-The minimum diameter of a sterilizer vent serving a bedpan steamer shall be 1 1/2 in. Multiple installations shall be sized according to Table RS 16-26.

(b) Boiler type sterilizer.-The minimum diameter of a

sterilizer vent stack shall be 2 in. when serving a utensil sterilizer, and 1 1/2 in. when serving an instrument sterilizer. Combinations of boiling type sterilizer vent connections shall be based on Table RS 16-26.

(c) Pressure sterilizers.-The minimum diameter of sterilizer vent stacks or the vertical stack vent from a single unit shall be 2 in. minimum. Stacks serving combinations of pressure sterilizer exhaust connections shall be sized according to Table RS 16-27.

(d) Pressure type instrument washer-sterilizer.-The minimum diameter of a sterilizer vent stack serving an instrument washer-sterilizer shall be 2 in.

(e) Roof penetration.-Vent shall be increased in size and extended through the roof in accordance with sanitary venting requirements.

P114.10 Water Supply.-

(a) Services.-All hospitals shall be provided with at least two water service connections. Whenever more

Reference Standard 16

than one street main is available, the connections shall be made to different street mains.

(b) Water supply protection.-The installation of the water supply shall meet all the requirements prescribed in Section P107.0, except as hereinafter provided. (See Table RS 16-28.)

(c) Hot water supply protection.-Hot water supply to patients' showers, therapeutic equipment, and continuous baths shall be provided with control valves automatically regulating the temperature of the water supply to the fixture. The valve shall fail in a closed position when the tempered water supply to the fixture exceeds 110 degrees F.

TABLE RS 16-27 STACK SIZES FOR PRESSURE STERILIZERS AND NUMBER OF CONNECTIONS PERMITTED

Stack Size (in.)	No. of Connections Permitted						
	Connection Size (in.)						
	3/4		1		1 1/4		1 1/2
1 1/2	3	or	2	or	1		
1 1/2	2	and	1				
2	6	or	3	or	2	or	1
2	3	and	2				
2	2	and	1	and	1		
2	1	and	1	and			1
3	15	or	1	or	5	or	3
3			1	and	2	and	2
3	1	and	5	and			1

TABLE RS 16-28 FIXTURE WATER SUPPLY PROTECTION^a

Fixtures	Type of Protection	Remarks
Aspirators	Separate water system	_____
Bedpan		
Washers	Vacuum breaker	
Washer Hose	Vacuum breaker	Locate 5 ft. above floor
Boiler type sterilizer	Air gap	Not less than twice the effective opening of the water supply
Exhaust condenser	Vacuum breaker	_____
Pressure type instrument washer-sterilizer	Vacuum breaker	_____
Pressure type sterilizer	Vacuum breaker	_____

Note-

^a Where vacuum breakers are used, they shall be installed after the last control valve. See section P107.2 for requirements for other fixtures.

P114.11 Vacuum systems.-

(a) Aspirators, water.-The use of water aspirators is prohibited.

(b) Bottle systems.-Vacuum systems intended for collecting, removing and/or disposing of blood, pus, and/or other fluids shall be protected by bottles (furnished as secondary equipment) installed near the outlet. Each vacuum outlet station shall be equipped so as to prevent fluids other than air from entering the vacuum piping systems.

(c) Central system equipment.-The collecting and/or control tanks in central systems shall be provided with drains for cleaning the tanks. The exhausts from vacuum pumps used in connection with a vacuum system shall discharge separately to the outdoor air above the roof or at such other locations as may be permitted by the Commissioner. The exhaust discharge

shall, in no case, be located so as to cause a hazard to public safety, health or welfare.

***P114.12 Oxygen and Nitrous Oxide Systems.**-Where oxygen and nitrous oxide systems are installed, the piping, outlets, manifolds, manifold rooms, and storage rooms shall be installed in accordance with the requirements of ANSI/NFiPA 99-1987 Standard for Health Care Facilities, as modified and ANSI/NFiPA 50-1985 Bulk Oxygen Systems at Consumer Sites. The alarms for the systems shall comply with Reference Standard RS 17-3 and the requirements of the fire department. ANSI/NFiPA 99-1987 shall be subject to the following modifications:

Section 4-3.1.4 Amend the initial sentence to read as follows: The central supply system shall be a system of cylinders and necessary supply equipment assembled as described

Reference Standard 16

in either 4-3.1.5 or 4-3.1.6, or a bulk supply system (4-3.1.7) which shall be of the permanently installed type.

Section 4-3.1.10 Add paragraph (b) to read as follows:

(b) The emergency oxygen supply connection shall not be used unless prior Fire Department approval and permits are obtained to store and use the emergency oxygen supply.

Section 4-3.2.2 Amend this section to read as follows:

4.3.2.2 Supply system and storage locations shall comply with 4-3.1.1.2; 4-3.1.1.3; 4-3.1.2.1(a); 4-3.1.2.1(c); 4-3.1.2.1(e); 4-3.1.2.1(g); 4-3.1.2.1(h); 4-3.1.2.1(i); 4-3.1.2.1(j); 4-3.1.2.1(k); 4-3.1.2.1(l); 4-3.1.2.2; 4-3.1.2.3; 4-3.1.3; 4-3.1.5.2; 4-3.1.8.2.

Section 4-4.1.2.1 Add paragraph (j) to read as follows:

(j) The gas content of medical gas piping systems shall be readily identifiable by appropriate labeling with the name of the gas contained. Such labeling shall be by means of metal tags, stenciling, stamping, or with adhesive markers, in a manner that is not readily removable. Labeling shall appear on the piping at intervals of not more than 20 feet and at least once in each room and each story traversed by the piping system. Where supplementary color identification of piping is used, it shall be in accordance with the gases and colors indicated in Compressed Gas Association Pamphlet C-9, Standard Color-Marking of Compressed Gas Cylinders Intended for Medical use in the United States. (1973).

Section 4-4.1.2.3 Add paragraph (g) to read as follows:

(g) Threaded connections using other than taper pipe threads, shall be prevented from loosening through the use of an anaerobic compound or any other method conforming with good engineering practice for such purpose.

**Local Law 12-1982; 1025-88 BCR*

****Section P115.0 Gas Piping**

***Local Law 30-1982*

*****P115.1 General Requirements For Gas Piping.-**

The gas piping system, system testing and appliance installation shall be as required by this section, section C26-1606.1 and section C26-1606.4 (d).

****Local Law 54-1970*

****P115.2 Gas Service Piping Connections.-**

(a) Gas service piping shall be fitted with a gas service line valve, the valve located on the supply side of the meter and service regulator, if a service regulator is required. If a plug type valve is used, it shall be constructed so as to prevent the core from being blown out by the pressure of the gas. In addition, it shall be of a type capable of being locked in the off position by the local gas utility. When the gas service line valve is inside the building, it shall be in an accessible location within 2 ft. of the point where the gas service connection enters the building or at such other location as may be permitted by the commissioner. Where the gas service connection is

installed through a building wall below ground, it shall be protected with a wall sleeve extending at least 4 in. beyond the outer side of the wall and at least 1 in. beyond the inner side of the wall. The sleeve shall be sealed at both ends to prevent the entry of water and gas. Gas service connections, installed through ground slab construction, shall be protected with a floor sleeve sealed at both ends to prevent the entry of water and gas. The sleeve shall extend at least 4 in. above the floor, and shall be installed as specified by the utility company providing the service. It shall terminate at least 4 in. outside the building.

(b) In all high pressure areas, the utility company providing the service may inspect the gas service line valve and regulator in accordance with the code requirements of the state of New York as set forth in 16 NYCRR, Part 255, in addition to the department of buildings in accordance with sections C26-1606.1 and C26-1606.4 (d).

(c) No gas service shall enter a structure at a horizontal distance of less than 10 ft. from the cellar termination of a stairway, nor shall any gas meters or gas regulators be located less than 10 ft. from such stairway termination. Where such services, meters and regulators are separated from the stairway termination by a permanent partition or wall having a fire-resistance rating of at least 1 hr. the foregoing shall not apply. Unless forbidden by other provisions of this code, locations under a stairway are exempt from this requirement.

(d) When the structure is erected on fill or on piles, provision shall be made to preclude possible damage to the gas service piping caused by settlement.

***Local Law 30-1982*

****P115.3 Gas Distribution Pressures.-**No gas distribution piping containing gas at a pressure in excess of 1/2 psig shall be run within a building, except that pressure not exceeding three psig is permitted for the following uses:

(a) commercial use, (b) industrial use; (c) other large volume use in which fuel requirements for boiler room equipment exceed 4000 cubic feet per hour and such large volume use is supplied through separate gas distribution piping to the boiler room. Gas pressure not exceeding 15 psig is permitted for boiler room equipment in excess of 100,000 cubic feet per hour provided the gas distribution piping is installed as provided for in P115.8. The use of pressure in excess of 15 psig shall be permitted for distribution piping provided all of the requirements of P115.8(n) are met.

***Local Law 30-1982*

****P115.4-Gas Regulator And Gas Regulator Vent Outlets.-**Gas meter piping supplying gas to a building at a pressure in excess of 1/2 psig shall be provided with a regulator that will reduce the pressure of the gas to 1/2 psig or less prior to entering the gas distribution

Reference Standard 16

pipng in the building, except where the use of higher pressure is permitted. Where gas distribution pressure in excess of 1/2 psig is permitted, it shall be regulated not to exceed the maximum pressure level as permitted by the code or commissioner.

(a) Inside gas meter piping operating at a pressure in

excess of 15 psig shall comply with the following:

(1) Where such piping is greater than 4-in. in diameter, the meter piping shall be installed in a properly ventilated meter room of 3 hour fire rated construction.

(2) The maximum distance from the service line valve to the regulator shall be limited as follows:

Service Line Valve Size	Maximum Distance (Linear Feet of Pipe)
up through 2" pipe size	4 feet
over 2" through 4" pipe size	8 feet
over 4" through 8" pipe size	15 feet
10" pipe size and larger	20 feet

(3) Where these maximum distances cannot be met, the following shall be required:

Footage (Linear Feet of Pipe) in Excess of Above Requirements	Additional Requirements
up to 5 ft.....	The meter room shall have 3 hour fire rating construction and adequate ventilation
over 5 ft. through 10 ft	Above requirements plus a combustible gas-detection alarm system
over 10 ft. through 15 ft	Above requirements plus controlled inspection by the customer or his representative as specified in section C26-106.3
over 15 ft. through 20 ft	Above requirements plus explosion venting per NFIPA Std. No. 68-1978; or alternative ventilation acceptable to the commissioner and automatic gas shutoff devices
over 20 ft.....	Above requirements plus suitable fire protection approved by the commissioner

For new gas installations made in existing structures, the above requirements shall be used to the extent feasible. Alternate designs may be considered by the commissioner.

(b) When located inside the building, each regulator shall be provided with a vent pipe that leads directly to the outdoor air. The vent pipe shall be sized according to local utility requirements. The vent outlet shall not be located under a window or any opening leading back into the premises or located below any overhang or projection. No gas regulator vent outlet shall be covered over, plugged up, or otherwise obstructed, and all gas vents shall be identified by suitable marking on the outlet on the outside of the building.

Gas appliance pressure regulators requiring access to the atmosphere for successful operation shall be equipped with vent leading to the outdoors, unless constructed or equipped with a vent limiting means to limit the escape of gas from the vent opening in the event of diaphragm failure.

****Local Law 30-1982**

****P115.5 Outside Gas Cut-off.-**

*(a) An outside gas service line valve or other outside emergency shut-off device or method acceptable to the commissioner and fire commissioner shall be installed in every gas service pipe outside the building. If buried, such valve, device or method shall be readily accessible from grade. Every existing service which is being replaced or refurbished shall be provided with such valve, device or method, but in any event, all existing gas services shall be provided with such valve, device or method by January 1, 2020 provided however, all occupancy groups other than J-3 shall be required to be completed by January 1, 2010. The minimum annual rate of installing such valve, device, or method shall be determined by the applicable utility; however, it shall be chosen to ensure timely completion of the program by the date specified herein. The applicable utility shall provide the Fire Department with suitable tools for operation of such emergency shut-off valves, devices or methods. The number of such tools required for

Reference Standard 16

supplying fire department units shall be determined by the fire department. On or before January 31, of each year, the applicable utility shall report to the Department of Buildings and the Fire Department the actual number of emergency shut-off valves installed for the preceding year.

(b) If the outside gas service line valve, emergency shut-off device or method is located below ground, it shall be installed in a protective housing, and a cover, easily identifiable shall be provided for the housing. The cover shall be flush with the surface of the ground and kept clear at all times so as to be accessible for immediate use.

(c) The valve or emergency shut-off device shall be capable of being readily operated by removing the cover of the housing and inserting a portable key or other device over the operating end of the valve or emergency shut-off device.

(d) If the outside gas service line valve is located above ground, it shall be suitably protected to prevent accidental vehicular impact and must be installed in accordance with the code requirements of the state of New York as set forth in 16 NYCRR Part 255.

***Local Law 30-1982*

**Local Law 89-1995*

P115.6 Gas Meter Location.-

(a) When located inside the building, meters shall be located as near as practicable to the point of entrance of the service and, where possible, the meters shall be located in the cellar or basement unless otherwise permitted by the commissioner. The meter location shall be clean, dry, and free of refuse, steam or chemical fumes. Meters shall be adequately protected against extreme cold or heat and shall be readily accessible for reading and inspection. The area in which the meter is located shall be properly ventilated. Notwithstanding the foregoing, outside meter installation shall be permitted in areas where the utility company certifies that dry gas is being distributed.

(b) In a multiple dwelling, no gas meter, other than the replacement of an existing meter shall be located in any boiler room or other room or space containing a heating boiler, in any stair hall, nor in any public hall above the cellar or above the lowest story if there is no cellar. However, in any multiple dwelling where there is an existing gas meter located in any boiler room or other room or space containing a heating boiler, one additional gas meter may be installed in such room or space, provided such additional gas meter is installed adjacent to the existing gas meter and is used in conjunction with the supply of gas for a gas-fired heating boiler or a gas-fired water heater used as a central source of supply of heat or hot water for the tenants residing in such multiple dwelling. Such additional gas meter may be installed only upon the condition that space heaters or hot water appliances in the dwelling units are eliminated.

(c) Gas meter rooms, when provided, shall at all times be kept clear of all rubbish; and shall not be used in any way for storage purposes, including material or equipment of any kind. A legible sign reading "Gas meter room-No storage permitted" shall be permanently and conspicuously posted on the exterior of the meter room door, except that the sign may be posted on the interior of the meter room door in buildings classified in occupancy group J-3. The lettering of such signs shall be of bold type at least one inch in height and shall be properly spaced to provide good legibility. The lettering and background shall be of contrasting colors. Where gas meters and related equipment are not located in a separate room but are located in an open floor area, no combustible material shall be stored or kept within five feet of such equipment; nor shall the gas meter be within three feet of any heating boiler or sources of ignition and, except for buildings in occupancy group J-3, there shall be a physical barrier required if the room is also used for storage purposes or the like.

P115.7 Gas Piping Materials And Fittings.-

(a) Piping materials and piping joints.-All materials used in gas distribution piping systems operating at 1/2 psig or less shall be in accordance with department of buildings' requirements and ANSI Z223.1-1974, National Fuel Code, except for the following modifications:

(1) Screwed fittings shall not be used for pipe size above 4 inches in diameter (see section P115.8(e) for distribution piping pressures over 1/2 psig).

(2) Delete paragraph 1.2.6.1(c) of this standard and substitute: "Plastic pipe, tubing and fittings shall not be used for gas distribution or meter piping."

(b) All materials used in gas distribution piping systems having a gas pressure above 1/2 psig shall conform to ANSI B31.2-1968, Fuel Gas Piping, and department of buildings requirements.

(c) All materials used in gas service and meter piping systems shall be in accordance with the requirements as specified by the utility corporation providing the service; and of the department of buildings.

(d) The permissible stress for gas piping shall be limited to not more than 20% of the yield strength of the piping, including all primary and secondary loads.

(e) Plastic pipe shall be limited to polyolefins and shall conform to ASTM D2513-*1976, Thermoplastic Gas Pressure Pipe, Tubing and Fittings.

(f) The definition of plastic (noun) is a material which contains as an essential ingredient an organic substance of large molecular weight, is solid in its finished state and, at some stage of its manufacture or processing can be shaped by flow. Thermoplastic is defined as a plastic which is capable of being repeatedly softened by increase of temperature and hardened by decrease of temperature.

**As enacted but "1974" probably intended.*

Reference Standard 16

P115.8 Installation Of Gas Piping.-

(a) The installation of gas service piping shall be made in accordance with the requirements of the utility corporation providing the service as regulated by Part 255, of Title 16, of the Official Compilation of Codes, Rules and Regulations of the State of New York. Further, such installation shall meet the requirements of the department of buildings.

(b) Gas service piping outside a structure shall be installed not less than 24 inches below grade, except that a lesser distance of not less than 18 inches may be permitted, provided the piping is adequately protected in accordance with the requirements of this code and the utility corporation supplying service, and the piping is not located below a driveway. Any piping that is exposed to outdoor temperatures or installed underground with a cover of less than 2 feet shall be protected against frost, except that frost protection may be omitted in areas where the utility company certifies that dry gas is being distributed.

(c) The installation of gas meter piping shall be made in accordance with the requirements of this code and the local utility company. Piping containing gas with a pressure exceeding 1/2 psig and the gas service pressure regulator which may be subjected to accidental vehicular impact shall be suitably protected.

(d) Welders installing gas piping within buildings at any pressure shall be qualified for all pipe sizes, wall thicknesses and all positions in accordance with either API 1104-1977, 14th edition, or ASME Section IX Boiler and Pressure Vessel Code, 1980 and requalified on an annual basis. The qualification testing shall be performed by an agency listed with the department of buildings, and the inspector shall have a minimum radiography qualification of Level II in accordance with the American Society of Non-Destructive Testing Recommended Practice Document No. SNT-TC-1A, Supplement A. Copies of the certified welder qualification reports shall be maintained by the responsible welding contractor and shall be made available to the department of buildings upon request.

(e) All welded gas distribution and meter piping main and branch supplies to customer equipment operating in excess of 3 psig inside buildings shall be butt welded; and shall be subject to controlled inspection, as set forth in section C26-106.3.

(f) Radiography shall be performed on all butt welds in gas meter and gas distribution piping operating at pressures exceeding 3 psig, within buildings, in accordance with API 1104-1977 or ASME Section IX Boiler and Pressure Vessel Code 1980.

(g) All requirements for installation of gas distribution piping with pressures of 1/2 psig or less shall be in accordance with P115.7 and Z223.1-1974 Part I, National Fuel Gas Code, subject to the following modifications. Section numbers referred to are those in

that standard.

1.2.10.14 Add the following to this section:

(h) Branches shall be taken off the riser with not less than a two elbow swing:

1.2.10.15 Electrical bonding and grounding.-Delete this section and replace it with the following:

The gas piping system shall not be used for an electrical ground.

(i) Where piping supplies equipment for incidental outside use, the minimum ground cover shall be 18 inches. Where compliance with this requirement would be unusually difficult, a lesser distance may be permitted provided the piping is adequately protected in accordance with the requirements of this code and the department of buildings. In all cases where piping is installed in concrete, screwed fittings shall not be used, and the piping shall be coated to prevent corrosion, and in all cases where corrosive conditions exist, the pipe shall be adequately protected against corrosion.

(j) Concealed piping as defined in sections 1.2.8 and 2.4.8 of Z223.1-1974 shall not include piping installed in pipe shafts. Where piping is installed in a shaft, the shaft shall have a fire protective rating as prescribed in the requirements for fire protection construction of the building code.

(k) All requirements for installation of gas distribution piping with pressure above 1/2 psig shall be in accordance with Z223.1 Part II National Fuel Gas Code. Gas distribution piping operating at a pressure of over 1/2 psig to 3 psig and of a size 4 inches or larger shall be welded. All gas distribution piping operating at a pressure above 3 psig shall be welded. All welding of gas distribution piping shall be subject to controlled inspection as set forth in section C26-103.3.

(l) When the structure is erected on fill or on piles, provisions shall be made to preclude possible damage to the gas distribution piping caused by settlement.

(m) Gas distribution piping operating at pressures above 1/2 psig shall be marked to identify the maximum pressure levels within the piping. All valves shall be suitably tagged to indicate the operating pressure level within the distribution piping. In no case shall there be any inter-connections between distribution piping at different pressure levels. Piping at different pressure levels in the same space shall be color coded.

(n) Gas distribution piping operating at pressure levels above 10 psig shall be located within spaces having a 3 hour fire rating for walls and partitions and a 2 hour fire rating for floors and ceiling. Areas containing gas distribution piping operating at pressure levels above 15 psig shall require and/or comply with all of the following:

(1) A 3 hour fire rating.

(2) A suitable fire protection system as approved by the commissioner.

(3) A combustible gas detection alarm system.

(4) Controlled inspection of the piping system as set forth in C26-106.3.

Reference Standard 16

(5) Gas pipe shafts shall not be located in stairways, shall be sealed to prevent any gas leakage from the shaft, shall conform to high hazard requirements, and shall be vented to the open air at the top.

(6) Compressors and/or turbines using gas at 15 psig or over shall be located in rooms provided with explosion venting in accordance with NFPA Std. No. 68-1978 and compressor, turbine, meter and boiler rooms shall be provided with adequate mechanical and fixed ventilation.

(7) The gas meter room shall be gas tight, shall be entered from the outside only, and shall be vented to the outer air only.

(8) Electrical equipment in meter, compressor and turbine rooms shall conform to the Electrical Code of the City of New York for Class 1 Division 1 occupancies.

(9) Any gas tank used shall conform to section C19-91.0(c) and (d), and compressing of gas shall be under the supervision of a person holding a certificate of fitness in accordance with section C19-91.0(b).

(10) Piping at different pressure levels in the same space shall be color coded.

(11) The concurrence of the fire commissioner shall be obtained for all such high pressure gas installations, operating at 15 psig or over.

(o) Plastic service piping, either insert or direct burial, conforming with section P115.7(c) may be installed subject to the following restrictions:

(1) Wherever plastic insert piping is used, the existing service piping shall act as a mechanical protection between the plastic piping and the surrounding environment. The remaining gas service pipe shall be prepared to the extent necessary to remove any sharp edges, projections, or abrasive material which could damage the plastic during and after insertion. Plastic pipe or tubing shall be inserted into the casing pipe in such a manner as to protect the plastic during the installation. The leading end of the plastic shall be closed before insertion. Care shall be taken to prevent piping from bearing on the end of the casing.

(2) Persons engaged in the installation of the plastic piping shall be formally trained, qualified, and certified by the serving utility company.

*(3) Plastic piping shall not extend more than 3 inches beyond the inner face of the building wall, and shall not be exposed inside the building. Plastic piping may extend into the building a maximum of one foot horizontally and four feet vertically immediately adjacent to the inner face of the building wall when encased in a metallic sleeve and constructed and vented so that uncontrolled gas cannot escape from the metallic sleeve inside the building.

**Local Law 38-1989*

(4) Joints shall be either mechanical or heat fusion joints, only. Each plastic pipe fusion joint must be made in accordance with written procedures that have been proven by destructive burst test to produce joints at least as strong as the pipe being joined.

a. When plastic pipe, tubing, or fittings of different

material specifications are joined together by heat fusion, a thorough investigation shall be made to determine that the materials are compatible for joining purposes. The joining method used must be compatible with the materials being joined. The recommendations of the manufacturer shall be considered when determining the method to be used.

b. Mechanical joints. When compression type mechanical joints are used, the gasket material in the coupling must be compatible with the plastic. An internal tubular rigid stiffener shall be used in conjunction with the coupling. The tubular stiffener shall reinforce the end of the pipe or tubing and shall extend at least to the outside end of the compression fitting when installed. The stiffener shall be free of rough or sharp edges and shall not be a force fit in the plastic. A split tubular stiffener shall not be used.

(5) Changes in direction with plastic piping may be made with bends, elbows and tees. Bends shall be free of buckles, cracks, or other evidence of damage. No miter joints are permitted. The pipe may be bent or deflected provided the radius shall not be less than the minimum recommended by the manufacturer.

(6) The minimum allowable wall thickness for plastic pipe shall be 0.090 inches.

(7) Plastic pipe shall be laid, and continuously supported, on undisturbed or well-compacted soil to minimize shear stresses. Backfill material for at least 4 inches over the plastic pipe shall be free from large rocks or sharp objects. The trench shall be backfilled to a height of 12 inches above the pipe in 6-inch lifts which shall be hand compacted. The remaining trench shall be backfilled in 12-inch lifts.

(8) Slack for thermal expansion and contraction or for external loading on direct-buried plastic services shall be provided by snaking the pipe from one side of the trench to the other. Where plastic piping is inserted for a distance of 50 feet or more allowances shall be made at the end connections to prevent pull out caused by thermal or by external loading.

(9) External sleeves shall be used on plastic service lines at main connections to minimize shear stresses.

*(10) Plastic pipe shall not be installed in areas where it may be exposed to temperatures below -20° F or above 140° F. Plastic pipe shall not be installed within 35 feet of an underground steam facility, nor in any vault in which a steam facility is located.

(11) The specific plastic pipe, tubing or fitting to be used shall be thoroughly investigated by the user and material serviceability determined for the conditions anticipated. The selected material shall be adequately resistant to the liquids and the chemical atmosphere which may be encountered. Care shall be exercised at all times to protect plastic material from fire, excessive heat, or harmful chemicals.

(12) The design pressure is not to exceed 100 psig for plastic gas service piping.

(13) The design pressure for plastic gas service piping or the nominal wall thicknesses for a given design

Reference Standard 16

pressure shall be determined by one of the following formulas:

**Local Law 38-1989*

$$P = \frac{2S \times F}{(R-1)} \quad \text{or} \quad P = \frac{2S \times t \times F}{(D-t)}$$

where:

D = Specified outside diameter, inches

P = Design pressure, psi

S = Long term hydrostatic strength, psi
(Determined in accordance with
ASTM D2513)

t = Specified wall thickness, inches

F = Plastic design factor = .32

R = Standard dimension ratio

(14) Inspection and handling provisions. Plastic piping components are susceptible to damage by mishandling. Gouges, cuts, kinks, or other forms of damage may cause failure. Injurious gouges or grooves shall be removed by cutting out the damaged portion as a cylinder and replacing it with a good piece. Care shall be exercised during handling and installation to prevent such damage. The serving utility shall inspect plastic piping and its components to ensure the absence of imperfections in materials, to ensure sound joints are made, and to ensure conformance with applicable state regulations.

P115.9 Gas Piping Sizes.-Pipe sizes for gas distribution shall be in accordance with ANSI Z223.1-1974, subject to the following modifications. Section numbers referred to are those in that standard.

1.2.4.3 Add the following at the end of this section: "Individual outlets to gas ranges shall not be less than 3/4 in."

Section P116.0 Swimming Pools and Display Pools or Fountains

P116.1 Swimming Pools.-

(a) **General requirements.**-Swimming pools regulated by the building code shall be designed, installed, and maintained in accordance with the requirements of this reference standard.

(b) **Prohibited pools.**-The installation of fill and draw pools is prohibited.

(c) **Toilet and shower facilities.**-

(1) Toilets shall be installed in properly ventilated rooms, and shall be conveniently located so as to facilitate their use before the bathers enter the showers. The number of toilets to be provided shall be predicated upon the maximum number of bathers, both adults and children, who can be accommodated at any one time. There shall be at least one toilet provided for every 50 female bathers, at least one toilet and one urinal provided for every 75 male bathers, and at least one wash basin adjacent to the toilets for every 60 persons.

(2) The number of showers to be provided shall be

predicated upon the maximum number of persons, both adults and children, who can be accommodated at any one time. At least one shower shall be provided for every 50 persons; but in no case shall there be less than two showers. Showers shall be supplied with hot and cold water, and shall be designed so that a proper mixture of hot and cold water can be obtained without the danger of scalding the bather. The entrance to the pool area from the dressing room shall be preceded by the shower room.

(d) **Drainage.**-

(1) At least one drainage outlet shall be installed in the deepest portion of the pool and shall be of sufficient size to drain the entire pool in 8 hours. The main drain outlets shall be provided with a vortex-and-suction-reducing device consisting of an outlet strainer or grating having a total open area equal to at least four times the area of the pool drain pipe. Or sufficient grating area shall be provided so that the maximum velocity through the grate does not exceed 1 1/2 fps. The minimum width of grating openings shall be 1/2 in. Multiple outlets shall be provided where the width of the pool is more than 30 ft. and such outlets shall not be spaced more than 30 ft. apart nor more than 15 ft. from the side walls. The pool drain connection shall be installed so as to prevent the reversal of flow from the sewer to the pool.

(2) Pool overflows shall be installed and constructed so that the overflow water is returned to the filter by means of overflow (scum) gutters, roll-out or deck level pool drains, or skimmers, along with the water returned to the filter through the main drain.

a. Overflow (scum) gutters shall extend completely around the pool, except at steps or recessed ladders in the shallow portion. The gutter shall be capable of continuously removing 50 percent or more of the recirculated water and returning it to the filter. All overflow gutters shall connect to the recirculation system through a properly designed surge tank. Where vacuum filters are used and are below the pool water level, the filter tank can be used as the surge tank. Piping from the gutter drains of the pool must be designed to rapidly remove the overflow water, but the maximum flow rate should not exceed 6 fps.

1. The gutters shall be designed so that they can be cleaned easily. The opening into the gutter beneath the coping shall be at least 4 in., and the interior of the gutter shall be at least 3 in. wide and 3 in. deep. Where large gutters are used, they shall be designed to prevent entrapment of the bather's arms or legs. They shall be designed in accordance with the standards of American public health service.

2. Overflow outlets or drains shall be installed at intervals sufficient to provide equal removal of the overflow from the entire surface of the pool. The outlet fittings shall connect to the return piping through 2 in.

Reference Standard 16

pipe connections, and the clear opening in the drain grating shall be at least equal to 1 1/2 times the cross-sectional area of the outlet pipe.

3. Continuous flow gutters with single or multiple outlets may be used provided they are self-cleansing and capable of maintaining an effective skimming action. Their use is normally limited to recirculating systems employing vacuum filters.

b. Roll-out deck level type pool overflows shall be designed to conform to the provisions for overflow rates as stated in a. above. The curb and handhold shall be designed so as to prevent splash-back of overflowed water. The design shall be subject to approval by the Commissioner.

c. Skimmers may be used in pools provided handholds are installed and provided at least one skimming device is installed for every 500 sq. ft. of pool surface area or fraction thereof. Skimmers shall be located so as to minimize interference with each other and insure proper skimming of the entire surface. Skimmers shall be built into the pool wall, and shall develop sufficient velocity on the pool water surface to induce surface skimming. The skimmers shall be provided with flow-rate adjustment valves to balance the system. Also, the skimmer shall meet the following requirements and the NSF standards.

1. The piping and other pertinent components shall be designed for a total capacity of at least 80 percent of the required filter flow, with a minimum skimmer flow-through rate of either 30 gpm or 3.75 gpm per lin. in. of weir.

2. The skimmer weir shall be capable of automatically adjusting to water level variations through a range of at least 4 in. The weir shall be of a buoyancy and design that will allow it to develop an effective velocity.

3. An easily removable and cleanable basket or screen through which all overflow water must pass shall be provided to trap large solids.

4. Provisions shall be made to prevent airlock in the suction line or to protect the pump in the event the pool water level drops below weir level. If an equalizer line is used, it shall be sized to meet the capacity requirements of the filter and pump, and shall be at least 2 in. in diameter and capable of providing at least 30 gpm of water for pump suction without air entrainment. The equalizer line shall be located at least 1 ft. below the lowest overflow level of the skimmer, and shall be provided with a valve that remains tightly closed under normal operating conditions but will automatically open when the skimmer becomes starved. Where vacuum filters are used, a separate suction pump shall be provided.

(e) Inlets.-A pool shall have inlets of such size and spacing so as to facilitate uniform circulation of water throughout the pool. The inlets shall be submerged sufficiently to prevent loss of chlorination or other disinfectant. There shall be no direct connection between the pool piping system and the domestic water supply system. An inlet shall be located not more than 5 ft. from the corner of the pool, and the inlet spacing shall not exceed 20 ft., unless otherwise permitted by the Commissioner.

Inlets shall be of the adjustable type and shall be located at least 12 in. below the pool water level.

(f) Recirculation and Filtration.-A pool shall have a water recirculation system consisting primarily of piping, pumps, filters, disinfecting equipment, and other standard accessory equipment that shall be adequate to clarify and disinfect the contents of the pool within 8 hrs. A flow meter shall be provided to indicate and record the rate of pumpage. The surface of the filter medium of all filters shall be of such size that the rate of filtration does not exceed 3 gpm per sq. ft. of surface area, except that when diatomaceous earth filters are used, the rate of filtration shall not exceed 2 gpm per sq. ft. of surface area. The recirculation system shall be kept in operation 24 hr. a day while the pool is in operation. Filters shall bear the seal of approval of NSF.

(g) Hair and lint catchers.-A strainer shall be provided that is easily accessible for cleaning. The strainer shall be of corrosive resistant materials with 1/8 in. openings or less, and shall provide a free flow area of at least four times the area of the pump suction lines.

(h) Disinfection.-

(1) The pool shall have an effective means of disinfection introduced by mechanical means. The equipment shall be capable of providing at least 8 ppm chlorine at the turnover rate of the pool.

(2) Chlorine, calcium hypochlorite, or similar compounds not containing ammonia, shall be used to disinfect a pool. The use of ammonia or ammonia compounds is prohibited.

* (3) Liquefied chlorine shall be used only when permitted by the Commissioner. It shall be stored only in a separate room or enclosure constructed of non-combustible materials having a fire-resistance rating of at least one hour and its use shall comply with the requirements of the fire department.

**Local Law 85-1973*

* (4) When chlorine gas is used as a disinfectant, at least two gas masks in good operating condition and of a type approved by the United States bureau of mines for high concentrations of chlorine gas, shall be provided. The gas masks shall be kept at a readily accessible point near the chlorinators feeding chlorine gas but outside the chlorinator room. The room housing chlorinator shall be located at grade level with direct egress to the outer air and provided with an automatic sprinkler system constructed in accordance with the provisions of article seventeen of the building code. The domestic water supply may be used to supply the sprinklers when it complies with section C26-1703.9(e). A drain shall be provided in the floor of the room.

**Local Law 85-1973*

(i) Heating.-A swimming pool shall not be heated by the direct injection of steam into the pool or by the direct installation of electrical heating elements in the pool.

(j) Make-up water.-Make-up water shall be supplied to the pool through an air gap by one of the following means:

(1) Through a fill spout above the pool rim, preferably installed under the diving board.

Reference Standard 16

- (2) Through a make-up tank.
- (3) Through the filter tank of vacuum diatomaceous earth filters.

(k) Water standards and quality.-

- (1) A pool shall use water from the public water supply system or such other source as may be approved by the department of health.
- (2) Water in a pool shall be treated and maintained so that not more than 200 bacteria per milliliter appear in the test sample, nor shall the test sample show a positive (confirmed) test for bacteria of the coliform group in any of five 10 milliliter portions.
- (3) The amount of free chlorine in the water, as determined by an orthotolidine test at 60 degrees F or less, shall be at least 0.4 ppm. The dechlorinated water shall have a pH value in the range of 7.2 to 8.2.
- (4) The surface of water in a pool shall be reasonably free from scum and floating matter. The water in a pool shall be sufficiently clear to permit a 6 in. black disc on a white field, placed on the bottom of the pool at the deepest point and 10 ft. from the side, to be clearly visible from the runway around the deep area of the pool. The bottom and sides of the pool shall be maintained free from sediment, dirt and slime.
- (5) Tests of pool water shall be performed in accordance with "standard methods for examination of water, sewage, and industrial wastes," published jointly by the American Public Health Association, American Water Works Association, and Federation of Sewage and Industrial Waste Associations, eleventh ed. The tests, as required by the department of health to maintain an operating permit for the pool, shall determine the presence of residual chlorine, the pH value of the water, and the clearness of the water. The tests shall be made by the pool operator as frequently as necessary throughout each day to maintain the standards required by this section.

(l) Pipe identification.-Pipes used for different purposes shall be painted different colors to facilitate identification. The colors shall be as follows:

potable water pipe-green
recirculation water pipe-light blue
backwash and wash water pipe-gray
chlorine pipe-yellow
well water pipe-red

P116.2 Display Pools and Fountains.-

- (a) Water connections.-**No direct or submerged water connections shall be made to a display pool or fountain.
- (b) Drainage.-**Each display pool or fountain shall be provided with a drain connection. The circulating or fountain pumps may be used to drain the pool to either the storm, sanitary, or combined sewer.
- (c) Recirculation required.-**Any display pool or fountain that will waste more than 2,000 gal. per day based on continuous 24 hr. operation shall be provided with a recirculation system. A statement from an architect or engineer attesting to the amount of water wasted shall be filed with the plans for any display pool or fountain.

(d) Treatment.-The water shall be treated with chemicals, either mechanically or hand fed, to prevent odors, mosquito breeding, and other health hazards. Chemicals used shall be nontoxic to animals or human beings. In lieu of chemical treatment, the entire pool may be drained at intervals provided the water wasted does not exceed the amount specified in (c) above.

Note: Excerpts from Local Law 7-1974

Section 1. The council finds that serious flooding and ponding problems exist in areas of the city of New York which are presently without adequate sewers for the disposal of storm water. The council further finds that these flooding and ponding problems endanger human life and cause substantial property damage. As the primary means of reducing these problems, the city of New York currently is engaged in an accelerated sewer construction program, approved by the council, of unprecedented scope. The city is also engaged in an active program of maintaining existing watercourses and other storm water disposal systems pursuant to orders of the city's Board of Health. It is the expectation of the council that in the next twenty years the city sewer construction program will provide a large network of storm sewers for the areas of the city which presently lack them. In addition, however, the council recognizes that present construction of new buildings and developments without adequate storm water drainage in these unsewered areas is worsening existing flooding and ponding problems, and that the stringent storm drainage requirements for property owners set forth in this local law, which terminates December thirty-first, nineteen hundred ninety three, are necessary as a temporary measure until the city has substantially advanced its accelerated sewer construction program.

§10 This local law shall take effect thirty days after it shall have become law. Its requirements insofar as they differ from or are additional to those of the administrative code of the city of New York in effect immediately prior to the effective date of this local law shall apply to the construction of all new buildings for which applications for new buildings permits have been filed on or after such effective date; provided, however, that such new or different requirements shall not apply to the construction of new buildings on specific sites for which schemes for storm water drainage have been approved by the environmental protection administration on or before such effective date if such construction lawfully commences within five years after such approval. A scheme for storm water drainage for the purpose of this section is an undetailed plan which shows the proposed drains, sewers and/or other means of storm water disposal, which the environmental protection administration normally requires property owners to submit to it prior to the submission of a detailed plan for the construction of such facilities. Effective date, May 16, 1974.

Reference Standard 16

INDEX Reference Standard RS-16

All references are to section numbers

A

Air conditioners, used water return, P107.17
Air conditioning, connections, see
Connections, Air Conditioning
Air gap, P107.18(1)
Ammonia, P116.1(h)(2)
Anchors, P106.1
Asbestos-cement pipe, joints, P103.1(a)
Aspirators, P107.13(2), P114.11(a)
Auxiliary water systems, P107.7

B

Backfill, P101.2
materials, P101.2(a)
Backflow, preventers, P107.13, P107.20(a)
protection against, P107.18
Back-siphonage, protection against, P107.18
Backwater valves, P105.9
design, P105.9(b)
Ball cocks, P107.8(b)
Baskets, indirect waste, P111.5(b)
Bathtubs, P104.8, P109.13(a)
Bedpan, hoppers, P114.3
steamers, P114.7(c)
sizing, P114.9(a)
vents, P114.8(c)
washers, P107.24, P114.3, P114.8(c)(1)c
connections, P107.24
drainage, P114.6(b)
Bidets, P107.13(1)
Boiler feedback system connections, P107.14
Boilers, waste piping, P111.1(b)(8)
Booster pumps, P107.9
Bowls, water closets, P104.2(d)
Branch vent size, P109.1(c)
Brazed joints, P103.1(b)

C

Cast iron joints, P103.1(c), see also Joints, cast iron
Caulking ferrules, materials, P102.4(e)(7)
Cesspools, P113.5
Check valves, P107.4
pump discharge, P107.9(f)
Chemical waste, materials, P102.4(b)(5)
piping materials, P112.2(c)
Chlorine, P116.1(h)(2)
Cleanouts, plug materials, P102.4(e)(10)

clearances, P105.3(g)
equivalent, P105.3(i)
location, P105.3(a)
size, P105.3(f)

Clear water waste discharging, P111.1(b)(6)

Clinic sinks, P114.3(a), P114.3(b)
drainage, P114.6(b)

Clothes washers, P104.12

Color marking, water supply identification, P107.10(d)

Common vents, P109.7

Concrete pipe joints, P103.1(i)

Condenser, exhaust, P114.7(e)

Connections, P103.0, see also Joints

air-conditioning, P107.16
metered premise, P107.16(3)
water, P107.16(1)
water conserving, P107.16(4)
water regulating, P107.16(5)

bedpan washers, P107.24

boiler feed systems, P107.14

cooling systems, P107.14

gas piping, P115.2

heating systems, P107.14

laboratory outlets, P107.24

preheating apparatus, P107.21

prohibited, P107.13

sewer, P108.2

abandonment, P108.3

solution tanks, P107.23

street sewer, P108.2

sub-stack, P109.3(f)

sump pump, P107.22

well pump, P107.22

Continuous-flow gutters, P116.1(d)(1)a

Controls, tank, P107.6(e)

valve, P107.6(h)

Copper tube, joints, P103.1(j)

Copper materials, P102.4(e)(5)

Couplings, joints, P103.1(k)

Crown vents, P109.8(c)

Curb valves, P107.2(b)(9)

Cut-off, emergency, P107.26(e)

D

Dead ends, P108.8(d)

Definitions (where required), P110.2(a)

Discharge, dishwasher, P111.6

laundry, P111.6

Dishwashing machines, P104.11

commercial, P104.11(d)

discharge, P111.6

domestic, P104.11(b)

Disinfection, P107.27

swimming pools, P116.1(h)

Display pools, P116.0, P116.2

Reference Standard 16

recirculation, P116.2(c)

Disposal field, see Subsurface disposal field

Distribution box, P113.0

Downspout materials, P102.4(e)(2)

Drainage, area, P108.7

bedpan washers, P114.6(b)

below sewer level, P108.6

clinic sinks, P114.6(b)

fixtures, value, P108.9(a)

continuous or semicontinuous flow, P108.9(b)

ice storage chests, P114.6(a)

one-, two-, or three-family buildings, P110.2(c)(3)

outlets, waste piping, P111.1(b)(5)

piping, change of directions, P108.8(b)

pitch of horizontal, P108.8(a)

prohibited fittings, P108.8(c)

provision for future fixtures, P108.8(e)

sizing, P108.10

underground, minimum size, P108.10(e)

sanitary, see also Sanitary drainage

sterilizer vent stack, P114.8(d)(2)

storm, P110.0, see also Storm drainage

sub-soil, P108.7

swimming pools, P116.1(d)

Drains

areaway, P110.2(e)

carrying clear water, P110.2(f)

floor, P104.17

sterilizer, P114.7(b)

vents, P109.8(d)

funnel, P104.19

material, P102.4(b)

roof, see Roof Drains

and sewers combined, size, P110.4(e)

sub-soil, materials, P102.4(e)(3)

swimming pools, P111.1(b)(7)

waste piping, P111.1(b)(3)

drainage system design, P110.2(g)

Draw pools, P116.1(b)

Drinking fountains, P104.16

prohibited, P104.16(c)

Drip pipes, P108.11

Drips, P110.2(c)

waste piping, P111.1(b)(5)

Dry wells, P110.13(d)

one-and two-family dwellings, P110.13(d)(2)

required, P110.13(d)

size, P110.13(d)(1)

E

Ejector, P108.6

Environmental Protection Administration, P110.2

Equivalent cleanouts, P105.3(i)

Excavation, P101.2

Exhaust condenser, P114.7(e)

Expansion joints, P103.1(l), P110.11

F

Field disposal, see Subsurface disposal field

Filters, swimming pool, P111.1(b)(7) P116.1(f)

Filtration, swimming pools, P116.1(f)

Fire lines, meters, P107.3(a)(2)

Fittings, gas piping, P115.6

materials, P102.4(d)

Fixtures, P104.0

accessibility, P104.1(d)

bathtubs, P104.8

clothes washers, P104.12

dishwashing machines, P104.11

drainage, P108.9

drinking fountains, P104.16

floor drains, P104.17

floor outlet, P104.2(c)

funnel drains, P104.19

garbage can washers, P104.14

hospital, P114.2

installing, P104.2

laundry trays, P104.13

lavatories, P104.7

minimum number, P104.1(a)

overflows, P104.3

physically handicapped, P104.1(c)

pools, P116.1

separate, P104.1(b)

showers, P104.9

sinks, P104.10

strainers, P104.15

traps, domestic dishwashers, P105.1(a)(4)

prohibited, P105.1(c)

sizes, P105.1(b)

separate, P105.1(a)

separate, exceptions, P105.1(a)

urinals, P104.5

vents P109.8

wall-hung vents, P109.8

water closets, see Water closets

water supply protection, P104.2(e)

Flanges, floor materials, P102.4(e)(9)

Flashings, roof drain, P110.10

waterproof, P109.4(c)

Flat decks, roof drain strainers, P110.9

Floor drains, P104.17, P107.13(5)

sterilizer, P114.7(b)

Flushing devices, P104.6

flush tanks, P104.6(d)

flushometer valves, P104.6(c)

urinals, P104.6

water closets, P104.6

Flush pipe materials, P102.4(e)(11)

Flush tanks, P104.6(d)

Reference Standard 16

ball cocks, P104.6(d)(2)
Flushometer valves, P104.6(c)
Fountains, P116.0, P116.2
drinking, P104.16
recirculation, P116.2(c)
Fresh air inlets, P108.5
Funnel drains, P104.19

G

Gap, air, P107.18(1)
Garbage can washers, P104.14
Gas meter, location, P115.6
outside installation, P115.6
Gas piping, P115.0
distribution pressures, P115.3
fittings, P115.7
installation, P115.8
materials, P115.7
meter location, P115.6
service connections, P115.2
sizes, P115.9
Gas service connections, P115.2
outside cut-off, P115.5
regulator and regulator vent outlets, P115.4
Glass pipe joints, P103.1(n)
Grading, vent, P109.5(a)
Gravity tank, P107.7(a)(1)
Grease interceptors, P105.4(d)
Gutters, continuous flow, P116.1(d)(1)a
pool overflow, P116.1(d)(1)
roof, size, P110.4(d)
swimming pool, P116.1(d)(1)a

H

Hair catchers, swimming pools, P116.1(g)
Hangers, materials, P106.0
Headers, vent, P109.3(e)
Heating equipment, water, valves, P107.6(f)
Heating systems, connections, P107.14
Hospital plumbing, P114.0
clinic sink drainage, P114.6(b)
fixtures, number of, P114.5
hot water supply, protection, P114.10(c)
mental hospital, P114.4
oxygen and nitrous oxide systems, P114.12
special fixtures, P114.2
requirements, P114.3
sterilizers, P114.3(d)
vacuum systems, P114.11
water supply, P114.10
protection, P114.10(a)
services, P114.10(a)
House pumps, P107.9
Hubs, double, P108.8(c)(2)

Hydropneumatic tanks, P107.8(f)

I

Ice storage chests, drainage, P114.6(a)
Indirect wastes, common, P111.2
piping, P111.0
sterilizer, P114.7(a)
Inlets, fresh air, P108.5
submerged, P107.20(a)
swimming pool, P116.1(e)
Installation, gas piping, P115.8
Institutional plumbing, P114.0
fixtures, number of, P114.5
Insulation materials, P102.4(e)(13)
Interceptors, P105.4
accessibility, P105.7
bottling establishments, P105.5(c)
grease, P105.4(d)
capacity, P105.4(d)(4)
laundry, P105.5(b)
maintenance, P105.8
oil, venting, P105.6(a)
sand, P105.5(a)
slaughter houses, P105.5(d)
venting, P105.6(b)

J

Joints, P103.0
asbestos-cement pipe, P103.1(a)
brazed, P103.1(b)
cast iron, P103.1(c)(d)
caulked, P103.1(d)(1), P103.1(e)
mechanical, P103.1(d)(2), P103.1(f)
clay sewer pipe, P103.1(g)
concrete pipe, P103.1(i)
concrete sewer pipe, P103.1(h)
copper tube (K or L), P103.1(j)
couplings, P103.1(k)
different piping material, P103.2
drainage pipe and fixtures, P103.3
expansion, P103.1(l), P110.11
roof drain, P110.11
glass pipe, P103.1(n)
hot poured, P103.1(m)
preformed, P103.1(o)
soldered, P103.1(q)
threaded, P103.1(r)
threadless copper, P103.1(s)
tightness, P103.4
unions, P103.1(t)
waterproofing openings, P103.5
wiped, P103.1(u)

L

Reference Standard 16

Laboratory outlet connections, P107.25

Laundry trays, P104.3, P109.13(a)

Lavatories, P104.7

Leaders, P110.7

exterior, materials, P102.4(e)(2)

size, P110.4

storm drainage, P110.7

storm water, P110.8

vertical size, P110.4(c)

Lead materials, P102.4(e)(6)

Lint catchers, swimming pool, P116.1(g)

M

Materials, anchors, P106.1

backfill, P101.2(a)

building sewers, P102.4(a)(3)

caulking ferrules, P102.4(e)(7)

chemical wastes, P102.4(b)(5)

 piping, P112.2(c)

cleanout plugs, P102.4(e)(10)

 slip, P103.1(p)

drainage systems, P102.4(b)

downspouts, P102.4(e)(2)

exterior leaders, P102.4(e)(2)

fittings, P102.4(d)

floor flanges, P102.4(e)(9)

flush pipes, P102.4(e)(11)

gas piping, P115.6

hangers, P106.0

insulation, P102.4(e)(13)

lead bends, P102.4(e)(4)

plastic, P102.2(b)

 requirements, P102.2(b)

roof drains, P102.4(e)(1)

sheet copper, P102.4(e)(5)

sheet lead, P102.4(e)(6)

soldering bushings, P102.4(e)(8)

standards, P102.2

subsoil drains, P102.4(e)(3)

supports, P106.1

toxic, P107.11

traps, P102.4(e)(4)

 tubular brass, P102.4(e)(12)

underground piping, P102.4(b)(2)

underground yard drainage, P102.4(b)(4)

venting, P102.4(c)

 above ground, P102.4(c)(1)

 chemical waste, P102.4(c)(3)

 systems, P102.4(c)

 underground, P102.4(c)(2)

 water distribution system pipe, P102.4(a)(2)

 water service pipe, P102.4(a)(1)

 water supply systems, P102.4(a)

Mental hospital plumbing, P114.4

Metal tags, water supply identification, P107.10(d)

Meters, P107.3

air conditioning, P107.3(a)(3)

buildings under construction, P107.3(a)(1)

fire lines, P107.3(a)(2)

gas, see Gas meter

location, P107.3(b)

miscellaneous fixtures, P107.3(a)(4)

refrigeration, P107.3(a)(3)

setting, P107.3(c)

size and type, P107.3(d)

N

Neutralizers, acid dilution pump, P112.2(h)

Neutralizing pits, P105.4

accessibility, P105.7

maintenance, P105.8

venting, P105.6

Neutralizing wastes, P105.5(e)

O

Offsets, P108.10(f), P109.3(d)

prohibited, P108.10(f)(5)

stack vents, P109.3(d)

Oil, interceptors, P105.6(a)

separators, P105.4(e)

wastes, P112.3

Outlets, drainage, P111.1(b)(5)

laboratory connections, P107.25

regulator, P115.3

swimming pool, P116.1(c)(3)

Overflows, P104.3

connection, P104.3(b)

design, P104.3(a)

swimming pools, P116.1(d)(1)

waste piping, P111.1(b)(3)

P

Permits, sanitary drainage piping, P108.1

storm drainage piping, P110.1

water supply, P107.1

Pipes, asbestos cement, joints, P103.1(a)

concrete, joints, P103.1(i)

drip, P108.11

flush, materials, P102.4(e)(11)

glass, joints, P103.1(n)

protection, P101.1

service, see Service pipe

swimming pool, identification, P116.1(1)

water service, materials, P102.4(a)(1)

Piping, chemicals, materials, P112.2(c)

concealed, P115.7(c)

drainage, sizing, P108.10

Reference Standard 16

gas, see Gas piping
horizontal, support intervals, P106.3(b)
indirect waste, P111.1
sanitary drainage, P108.0
permits, P108.1
sewer, sizing, P108.10(b)
storm drainage, P110.0
permits, P110.1
storm water, P110.8
swimming pool, P116.1(1)
underground, materials, P102.4(b)(2)
used, P107.12
vent, materials, P112.2(c)
vertical, support intervals, P106.3(a)
wastes, see Waste piping
Pits, neutralizing, P105.4, see also Neutralizing pits
seepage, P113.5(a), see also Seepage pits
Plastic materials, P102.2(b)
Plumbing fixtures, see Fixtures
Pools, display, see Display pools
swimming, see Swimming pools
Potable water, protection, P107.10
Preheating apparatus, P107.21
Pressure relief valves, P107.26(b), P107.26(c)
Pressure tanks, waste piping, P111.1(b)(8)
Pressure, sterilizers, P114.7(d)
sizing, P114.9(c)
vent, P114.8(d)
Pumps, booster, P107.9
low pressure cut-off, P107.9(e)
directly off street main, P107.9(a)
house, P107.9

R

Radioactive wastes, P112.4
Ratproofing, P101.4
Receiving tanks, P108.6(c)
Receptors, P111.5
prohibited fixtures, P111.5(c)
standpipe, P111.5(a)(3)
waste, P111.5(a)(1)
Refrigeration, meters, P107.3(a)(3)
Refrigerators, waste piping, P111.1(b)(8)
Relief pipes, waste piping, P111.1(b)(3)
Relief valves, P107.6(f)
waste piping, P111.1(b)(8)
Relief vents, P109.9
size, P109.1(b)
Riser valves, P107.6(b)
Roof drain, flashing, P110.10
materials, P102.4(e)(1)
strainers, P110.9
flat decks, P110.9
general use, P110.9(a)
Roof gutters, P110.4(d)

S

Saddles, P108.8(c)
Sand interceptors, P105.5(a)
Sanitary drainage, combining with storm, P110.8(c)
piping, P108.1
permits, P108.1(a)
Sanitary and storm sewers, P110.12
Seats, water closets, P104.4(d)
Seepage pits, P113.5(a)
capacity, P113.10(a)
construction, P113.10(b)
distribution box, P113.8
Seepage trenches, P113.5(a)
Separators, P105.4
accessibility, P105.7
maintenance, P105.8
oil, venting, P105.6(a)
oil and flammable liquids, P105.4(e)
connection to sewer, P105.4(e)(4)
design, P105.4(e)(2)
venting, P105.4(e)(3)
oil storage tank, P105.4(e)(5)
slaughter houses, P105.5(d)
Septic tanks, P113.5(a), P113.7
capacity, P113.7
construction, P113.7
design, P113.7(d)
maintenance, P113.12
Service pipe
clearance, P107.2(b)(10)
curb valves, P107.2(b)(9)
goosenecks on, P107.2(b)(8)
house control valves, P107.2(b)(12)
installation, P107.2(b)(7)
protection, P107.2(b)(6)
size, P107.2(b)(2)
test, P107.2(b)(11)
Sewage disposal, cesspool, P113.5
housing development, P113.4
individual, P113.3
seepage pits, P113.5(a)
seepage trenches, P113.5(a)
septic tank, P113.5(a)
Sewage ejector, pneumatic, P108.6(e)
Sewage system, building materials, P102.4(a)(3)
individual, P113.1
Sewer connections, P108.2
Sewer, disposal of storm water, P110.2(b)
Sewer, repairs, P110.2(i)
Sewers and drains combined size, P110.4(e)
Showers, P104.9
swimming pools, P116.1(o)
Sinks, P104.10, P109.13(a)
clinic, P114.3(a), P114.3(b)

Reference Standard 16

- drainage, P114.6(b)
 - Skimmers**, P116.1(d)(1)
 - swimming pool, P116.1(c)
 - Sleeves**, P101.3
 - Slip joints**, P103.1(p)
 - Soil percolation, tests**, P113.9
 - Soil stacks, minimum size**, P108.10(c)
 - Solution tanks, connections**, P107.23
 - Stack vents**, P109.3, P109.6
 - minimum size, P109.3(a)
 - offsets, P109.3(d)
 - required, P109.3(b)
 - Standpipe receptors**, P111.5(a)(3)
 - Sterilizers**, P107.13(4)
 - boiler type, sizing, P114.9(b)
 - floor drain, P114.7(b)
 - hospital, P114.3(d)
 - indirect wastes, P114.7(a)
 - pressure, P114.7(d)
 - sizing, P114.9(c)
 - vent, P114.8(d)
 - vent stack, drainage, P114.8(d)(2)
 - vent, stack sizing, P114.9
 - waste, P114.7(f)
 - waste piping, P111.1(b)(4)
 - Stop-and-waste valves**, P107.6
 - Storm drainage**, P110.0
 - areaways, P110.2(a), P110.2(b)
 - capacity, for street, P110.2(h)
 - combining with sanitary, P110.8(c)
 - continuous flow valves, P110.5
 - contractual obligations, P110.2(1)
 - control flow, P110.6
 - leaders, P110.7
 - on-site disposal, P110.13
 - piping, P110.0
 - sanitary sewer, P110.3
 - size, P110.4
 - time, of construction, P110.2(k)
 - traps, P110.7
 - where required, P110.2
 - Storm sewers, continuous flow valves**, P110.5
 - sanitary sewers, P110.12
 - size, P110.4(b)
 - Storm water, leaders**, P110.8
 - piping, P110.8
 - Strainers, indirect waste**, P111.5(b)
 - roof drain, P110.9
 - Subsoil drainage**, P108.7
 - Subsurface disposal field**, P113.11
 - construction, P113.11(b)
 - distance requirements, P113.11(e)
 - maintenance, P113.12
 - size, P113.11(d)
 - Sump pits**, P108.6(a), P108.6(c)
 - Sump pump, connections**, P107.22
 - Sumps**, P111.5
 - acid dilution, P112.2(g)
 - neutralization, P112.2(g)
 - waste, P111.5(a)(1)
 - Supports, intervals**, P106.3
 - base of stacks, P106.3(c)
 - horizontal piping, P106.3(b)
 - vertical piping, P106.3(a)
 - materials, P106.1
 - Swimming pools**, P116.0, P116.1
 - chlorine, P116.1(h)(2)
 - disinfection, P116.1(h)
 - drainage, P116.1(d)
 - draw pools, P116.1(b)
 - filtration, P111.1(b)(7), P116.1(f)
 - fixtures, required, P104.9
 - free chlorine, P116.1(k)(3)
 - gutters, P116.1(d)(1)a
 - hair and lint catchers, P116.1(g)
 - heating, P116.1(i)
 - inlets, P116.1(e)
 - main draw outlets, P116.1(c)(3)
 - make-up water, P116.1(j)
 - overflow, P116.1(d)(1)
 - pipe identification, P116.1(1)
 - recirculation, P116.1(f)
 - showers, P116.1(c)
 - skimmers, P116.1(d)(1)
 - toilets, P116.1(c)
 - waste piping, P111.1(b)(7)
 - water standards, P116.1(k)
- ## T
- Tank controls**, P107.6(e)
 - Tanks, ball cocks**, P107.8(b)
 - cleaning, P107.8(g)
 - flush, P104.6(d)
 - gravity, P107.7(a)(1)
 - hot water storage, P107.26(g)
 - location, P107.26(i)
 - hydropneumatic, P107.8(f)
 - oil storage, P105.4(e)(5)
 - overflows, P107.8(a)
 - painting, P107.8(g)
 - pressure, waste piping, P111.1(b)(8)
 - prohibited location, P107.8(d)
 - receiving, P108.6(c)
 - septic, see Septic tanks
 - suction, P107.8(a), P107.9(b)
 - fill line, P107.9(d)
 - size, P107.9(c)
 - Temperature relief valves**, P107.26(b), P107.26(d)
 - Toilets, swimming pools**, P116.1(c)
 - Toilets, workmen**, P101.5
 - Toxic materials**, P107.11

Reference Standard 16

Traps, P105.0

- bedpan vent stack, P114.8(c)(2)
- building, P105.2, P108.4
- domestic dish washers, P105.1(a)(4)
- materials, P102.4(e)(4)
- prohibited, P105.1(c)
- seals, protection, P109.2
- separate, P105.1(a)
- separate for each fixture, P105.1
- storm drain, P110.7
 - equivalent, P110.7(c)
- water supply, P107.2

Trenches, see page, P113.5(a)

Trenching, P101.2

- methods, P101.2(b)

U

Urinals, P104.5

- flushing devices, P104.6
- prohibited, P104.5(a)
- wall-hung trough, P104.5(b)

V

Vacuum breakers, P107.13, P107.18(2), P107.20, P107.23, P107.24

Vacuum filters, swimming pools, P116(d)(1)a

Vacuum systems, P114.11

Valves, backwater, P105.9, P108.7

- check, P107.4, P107.9(f)
- control, P107.6(h)
- curb, P107.2(b),(9)
- dwelling units, P107.6(c)
- flushometer, P104.6(c)
- individual fixture, P107.6(d)
- pressure relief, P107.26(b), P107.26(c)
- relief, P107.6(f)
- waste piping, P111.1(b)(8)
- riser, P107.6(b)
- stop-and-waste, P107.6
- temperature relief, P107.26(b), P107.26(d)
- vacuum relief, P107.26(f)
- water heating equipment, P107.6(f)

Vapor vents, P114.8

Vent headers, P109.3(e)

Vent piping, materials, P112.2(c)

Vents,

- bedpan, P114.8(c)
- branch, P109.1(c)
- common, P109.7
- connections,
 - at base and top, P109.3(c)
- crown, P109.8(c)
- extensions, P109.4(e)(2)
 - above roofs, P109.4(a)

- outside building, P109.4(f)
- fixture, P109.8
 - floor drain, P109.8(d)
 - location, P109.8(b)
- floor drain, P109.8(d)
- grading, P109.5(a)
- height above fixtures, P109.5(b)
- indirect waste piping, P111.3
- interceptors, P105.6(d)
- materials, P102.4(c), see also Materials, venting
- pressure sterilizer, P114.8(d)
- relief, P109.9
 - offsets, P109.9(a)
 - yoke, P109.9(b)
- roof penetration, P114.9(e)
- size, P109.1
 - branch, P109.1(d)
 - extension, P109.4(b)
 - individual, P109.1(a)
 - relief, P109.1(b)
- stack, see Stack vents
- suds pressure zones, P109.10
- terminals, P109.4
 - location, P109.4(e)
- vapor, P114.8
- wet, P109.6

Vent stacks, bedpan, P114.8(c)(2)

- minimum size, P109.3(a)
- offsets, P109.3(d)
- pressure sterilizer, P114.8(d)
- required, P109.3(b)
- size, P109.1(d)
- sterilizer, sizing, P114.9
- sub-stack connections, P109.3(f)

Vent systems, combination with waste system, P109.11

W

Washers, bedpan, see Bedpan washers

- clothes, P104.12
- garbage can, P104.14

Washing machines, P109.10(a)

Waste piping, boilers, P111.1(b)(8)

- clear water waste, P111.1(b)(6)
- chemical, P112.2(c)
- drainage, P111.1(b)(3)
 - outlets, P111.1(b)(5)
- drips, P111.1(b)(5)
- food handling devices, P111.1(b)(1)
- indirect, P111.0
- laundry washers and extractors, P111.1(b)(2)
- overflows, P111.1(b)(3)
- pressure tanks, P111.1(b)(8)
- refrigerators, P111.1(b)(8)

Reference Standard 16

- relief pipes, P111.1(b)(3)
- relief valves, P111.1(b)(8)
- sizing, P111.4
- sterilizers, P111.1(b)(4)
- swimming pools, P111.1(b)(7)
- Waste receptors**, P111.5(a)(1)
- Wastes, chemical**, P102.4(b)(5), P112.2
 - piping materials, P112.2(c)
 - flammable solvents, P112.3
 - indirect, see also Indirect wastes
 - piping, P111.1
 - strainers, P111.5(b)
 - industrial, P112.1
 - neutralizing, P105.5(e)
 - oil, P112.3
 - radioactive, P112.4
 - sampling manholes, P105.10
 - sterilizer, P114.7, P114.7(f)
- Waste stacks, minimum size**, P108.10(c)
- Waste systems, combinations with vent system**, P109.1(r)
- Water, potable, protection**, P107.10
- Water closets, children's**, P104.4(c)
 - flushing devices, P104.6
 - pipe connections, P104.4(e)
 - prohibited, P104.4(a)
 - public use, P104.4(b)
 - seats, P104.4(d)
 - wall-hung bowls, P104.2(d)
- Water conserving, air conditioners**, P107.16(4), P107.16(9)
- Water hammer**, P107.5(f)
- Water regulating, air conditioners**, P107.16(5)
- Water service pipe**, P102.4(a)(1)
- Water standards, swimming pools**, P116.1(k)
- Water supply**, P107.0
 - color marking, P107.10(c)
 - distribution, P107.5
 - design, P107.5(a)
 - maximum pressures, P107.5(d)
 - minimum branch size, P107.5(c)
 - minimum pressure, P107.5(b)
 - minimum riser size, P107.5(e)
 - water hammer, P107.5(f)
 - hospital plumbing, P114.10
 - hot, P107.26
 - return circulation, P107.26(a)
 - identification, P107.10(d)
 - metal tags, P107.10(d)
 - permits, P107.1
 - piping, P107.12
 - potable, identification, P107.10(b)
 - protection of, P107.10
 - protection, P104.2(e)
 - hospital, P114.10(a)
 - prohibited connections, P107.13
 - service, P107.2(b), see also Service pipe
 - pipe installation, P107.2(b)(7)
 - pipe protection, P107.2(b)(6)
 - separation from building sewer, P107.2(b)(4)
 - size of fire line, P107.2(b)(3)
 - size of taps, P107.2(b)(2)
 - taps to city mains, P107.2
- Water systems, auxiliary**, P107.7
 - dual, P107.10(b)
 - gravity tank, P107.7(a)(1)
 - hydropneumatic booster, P107.7(a)(3)
 - potable, disinfection, P107.27
 - pressure booster pump, P107.7(a)(3)
- Wells, dry**, P110.13(d)
 - required, P110.13(d)
 - size, P110.13(d)(1)
- Wiped joints**, P103.1(u)

Y

- Yoke vents**, P109.9(b)